

2. Turn the adjustment potentiometer counter-clockwise until the amber indicator turns off.
3. Turn the adjustment potentiometer clockwise until the amber indicator turns on.
4. Replace the darkest object with the brightest background at the closest application distance.
5. Turn the adjustment potentiometer clockwise until the amber indicator turns on.
6. Turn the adjustment potentiometer counter-clockwise approximately half of the adjustment rotation from the previous step. This places the cutoff distance approximately half-way between the object and the background switch points. If sufficient separation exists between the object and background, the sensor is ready for operation.

## IO-Link Interface

IO-Link is a point-to-point communication link between a master device and sensor. Use IO-Link to parameterize sensors and transmit process data automatically.

For the latest IO-Link protocol and specifications, see [www.io-link.com](http://www.io-link.com).

Each IO-Link device has an IODD (IO Device Description) file that contains information about the manufacturer, article number, functionality etc. This information can be easily read and processed by the user. Each device can be unambiguously identified via the IODD as well as via an internal device ID. Download the Q20's IO-Link IODD package (p/n 209012) from Banner Engineering's website at [www.bannerengineering.com](http://www.bannerengineering.com).

Banner has also developed Add On Instruction (AOI) files to simplify ease-of-use between the Q20, multiple third-party vendors' IO-Link masters, and the Logix Designer software package for Rockwell Automation PLCs. Three types of AOI files for Rockwell Allen-Bradley PLCs are listed below. These files and more information can be found at [www.bannerengineering.com](http://www.bannerengineering.com).

**Process Data AOIs**—These files can be used alone, without the need for any other IO-Link AOIs. The job of a Process Data AOI is to intelligently parse out the Process Data word(s) in separate pieces of information. All that is required to make use of this AOI is an EtherNet/IP connection to the IO-Link Master and knowledge of where the Process Data registers are located for each port.

**Parameter Data AOIs**—These files require the use of an associated IO-Link Master AOI. The job of a Parameter Data AOI, when working in conjunction with the IO-Link Master AOI, is to provide quasi-realtime read/write access to all IO-Link parameter data in the sensor. Each Parameter Data AOI is specific to a given sensor or device.

**IO-Link Master AOIs**—These files require the use of one or more associated Parameter Data AOIs. The job of an IO-Link Master AOI is to translate the desired IO-Link read/write requests, made by the Parameter Data AOI, into the format a specific IO-Link Master requires. Each IO-Link Master AOI is customized for a given brand of IO-Link Master.

Add and configure the relevant Banner IO-Link Master AOI in your ladder logic program first; then add and configure Banner IO-Link Device AOIs as desired, linking them to the Master AOI as shown in the relevant AOI documentation.

## Specifications

---

### Supply Voltage

10 V dc to 30 V dc (10% maximum ripple within specified limits)

### Maximum Power Consumption (exclusive of load)

Less than 300 mW

### Sensing Beam

Visible red LED, 640 nm

### Supply Protection Circuitry

Protected against reverse polarity and transient voltages

### Output Configuration

Solid-state complementary: open collector NPN or PNP, depending on model

Rating: 50 mA per output

**Output Voltage High:** Greater than  $V_{supply} - 2.5 V$

**Output Voltage Low:** Less than 2.5 V

For loads less than 1 Meg Ohm

Protected against false pulse on power-up and continuous overload or short circuit of outputs

### Output Response

1.7 milliseconds ON; 1.1 milliseconds OFF

**Note:** 200 millisecond delay on power-up; outputs do not conduct during this time

### Adjustments

Single-turn adjustment potentiometer sets the cutoff distance between minimum and maximum positions

### Repeatability

130  $\mu s$  (standard mode)

### Indicators

2 LED indicators on sensor top:

Green solid: Power on

Amber: Light sensed

Amber flashing: Marginal sensing condition

### Construction

ABS front housing and gain adjuster, PMMA lenses; Copolyamide rear housing

**Connections**

2 m (6.5 ft) unterminated 4-wire PVC cable; 9 m (30 ft) unterminated 4-wire PVC cable; 150 mm (6 in) PVC cable with a 4-pin M8/Pico-style quick disconnect; 150 mm (6 in) PVC cable with a 4-pin M12/Euro-style quick disconnect or Integral 4-pin M8/Pico-style quick disconnect, depending on model  
Models with a quick disconnect require a mating cordset

**IO-Link Interface**

Supports Smart Sensor Profile: Yes  
Baud Rate: 38400 bps  
Process Data Widths: 16 bits  
IODD Files: Provides all programming options plus additional functionality; please see the IO-Link Data Reference Guide for more details

**Environmental Rating**

IEC IP67; NEMA 6

**Operating Conditions**

-20 °C to +60 °C (-4 °F to +140 °F)  
95% relative humidity at 50 °C (non-condensing)

**Vibration and Mechanical Shock**

All models meet MIL-STD-202F, Method 201A (Vibration: 10 Hz to 60 Hz maximum, 0.06 inch (1.52 mm) double amplitude, 10G maximum acceleration) requirements. Also meets IEC 60947-5-2 (Shock: 30G 11 ms duration, half sine wave) requirements.

**Certifications**



**Required Overcurrent Protection**



**WARNING:** Electrical connections must be made by qualified personnel in accordance with local and national electrical codes and regulations.

Overcurrent protection is required to be provided by end product application per the supplied table.  
Overcurrent protection may be provided with external fusing or via Current Limiting, Class 2 Power Supply.  
Supply wiring leads < 24 AWG shall not be spliced.  
For additional product support, go to [www.bannerengineering.com](http://www.bannerengineering.com).

Supply Wiring (AWG)	Required Overcurrent Protection (Amps)
20	5.0
22	3.0
24	2.0
26	1.0
28	0.8
30	0.5

Dimensions

**Cabled and Pigtail QD Models**

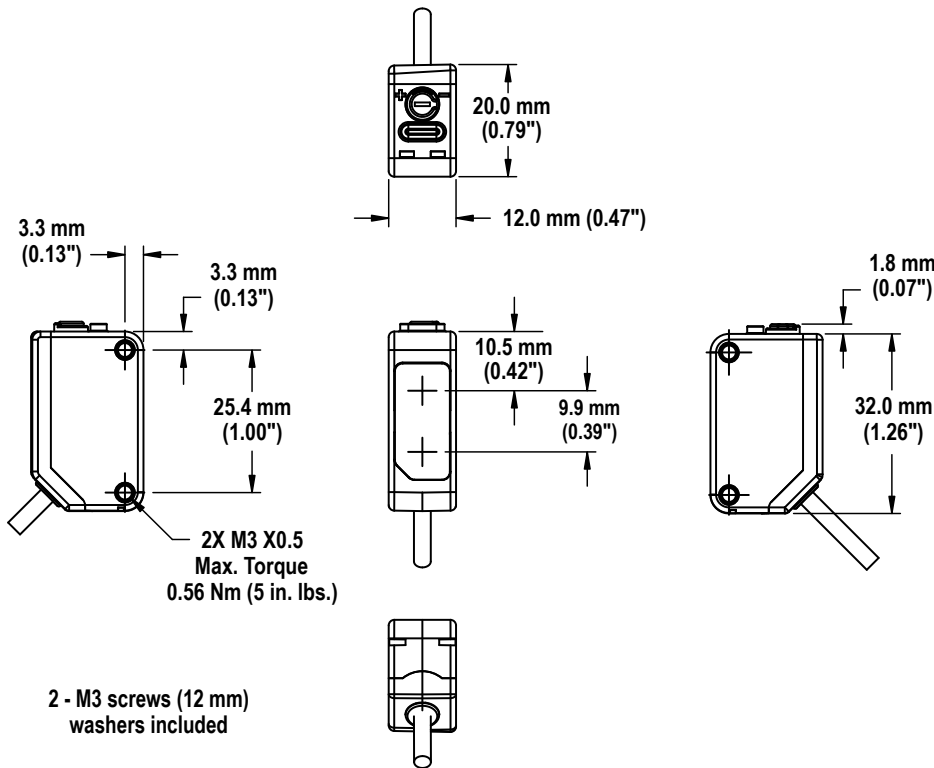

**Integral QD Models**

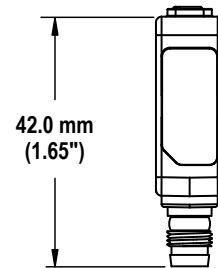

Performance Curves

The minimum sensing range for 6% reflectivity is 14 mm.