

# APDS-9301

## Miniature Ambient Light Photo Sensor with Digital (I<sup>2</sup>C) Output



### Data Sheet

#### Description

The APDS-9301 is Light-to-Digital Ambient Light Photo Sensor that converts light intensity to digital signal output capable of direct I<sup>2</sup>C interface. Each device consists of one broadband photodiode (visible plus infrared) and one infrared photodiode. Two integrating ADCs convert the photodiode currents to a digital output that represents the irradiance measured on each channel. This digital output can be input to a microprocessor where illuminance (ambient light level) in lux is derived using an empirical formula to approximate the human-eye response.

#### Application Support Information

The Application Engineering Group is available to assist you with the application design associated with APDS-9301 ambient light photo sensor module. You can contact them through your local sales representatives for additional details.

#### Features

- Approximate the human-eye response
- Precise Illuminance measurement under diverse lighting conditions
- Programmable Interrupt Function with User-Defined Upper and Lower Threshold Settings
- 16-Bit Digital Output with I<sup>2</sup>C Fast-Mode at 400 kHz
- Programmable Analog Gain and Integration Time
- Miniature ChipLED Package
  - Height – 0.55mm
  - Length – 2.60mm
  - Width – 2.20mm
- 50/60-Hz Lighting Ripple Rejection
- Typical 3.0V Input Voltage
- Low Active Power (0.6 mW Typical) with Power Down Mode
- RoHS Compliant

#### Applications

- Detection of ambient light to control display backlighting
  - Mobile devices – Cell phones, PDAs, PMP
  - Computing devices – Notebooks, Tablet PC, Key board
  - Consumer devices – LCD Monitor, Flat-panel TVs, Video Cameras, Digital Still Camera
- Automatic Residential and Commercial Lighting Management
- Automotive instrumentation clusters
- Electronic Signs and Signals

#### Ordering Information

Part Number	Packaging Type	Package	Quantity
APDS-9301-020	Tape and Reel	6-pins Chipled package	2500

## Functional Block Diagram

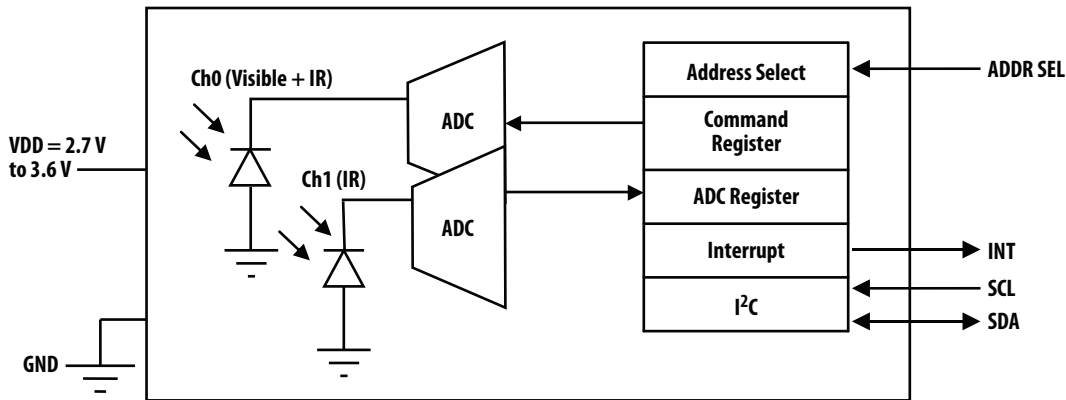

## I/O Pins Configuration Table

Pin	Symbol	Type
1	V <sub>DD</sub>	Voltage Supply
2	GND	Ground
3	ADDR SEL	Address Select
4	SCL	Serial Clock
5	SDA	Serial Data
6	INT	Interrupt

## Absolute Maximum Ratings

Parameter	Symbol	Min	Max	Unit
Supply voltage	V <sub>DD</sub>	–	3.8	V
Digital output voltage range	V <sub>O</sub>	-0.5	3.8	V
Digital output current	I <sub>O</sub>	-1	20	mA
Storage temperature range	T <sub>stg</sub>	-40	85	°C
ESD tolerance	human body model	–	2000	V

## Recommended Operating Conditions

Parameter	Symbol	Min	Typ	Max	Unit	Condition
Supply Voltage	V <sub>DD</sub>	2.7	3.0	3.6	V	
Operating Temperature	T <sub>a</sub>	-30	–	85	°C	
SCL, SDA input low voltage	V <sub>IL</sub>	-0.5	–	0.8	V	
SCL, SDA input high voltage	V <sub>IH</sub>	2.1	–	3.6	V	

## Electrical Characteristics

Parameter	Symbol	Min	Typ	Max	Unit	Conditions
Supply current	I <sub>DD</sub>	–	0.24	0.6	mA	Active
		–	3.2	15	μA	Power down
INT, SDA output low voltage	V <sub>OL</sub>	0	–	0.4	V	3 mA sink current
		0	–	0.6	V	6 mA sink current
Leakage current	I <sub>LEAK</sub>	-5	–	5	μA	