

DIL R Contactor Relays

Basic Units, Modules

Control Relays, Contactor Relays, Electronic Timing Relays



Contacts	Rated operational current I _e AC-15 220 V 380 V 230 V 400 V 240 V 415 V	Conv. therm. current I _{th}	AC operation			Circuit symbol	Distinctive number and version of combination	Price See Price List	Std. pack
			Type	Article no.					

M = Make
B = Break

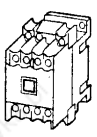
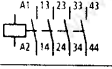
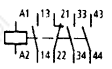
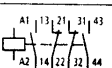
Basic units with interlocked opposing contacts

	4 M -	6	4	16		40 E - -	DIL R 40 (230V 50HZ) 043756	1 off
	3 M 1 B					- 31 E -	DIL R 31 (230V 50HZ) 043768	
	2 M 2 B					- - 22 E	DIL R 22 (230V 50HZ) 043780	

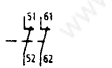
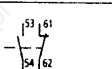
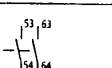
Auxiliary contact modules with interlocked opposing contacts

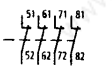
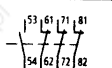
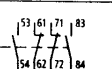
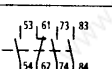
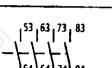
	2-pole - 2 B	6	4	16		42 E 33 24	02 DIL 098145	5 off
	1 M 1 B					51 E 42 33	11 DIL 010345	
	2 M -					60 E 51 42	20 DIL 012718	
	4-pole - 4 B	6	4	16		44 E 35 26	04 DIL 015091	5 off
	1 M 3 B					53 E 44 35	13 DIL 017464	
	2 M 2 B					62 E 53 44	22 DIL 019837	
	3 M 1 B					71 E 62 53	31 DIL 010752	
	4 M -					80 E 71 62	40 DIL 022210	

Pneumatic timer modules, time ranges of 0.2 – 30 s and 20 – 180 s

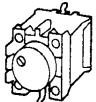
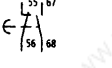
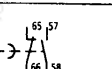
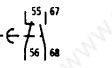
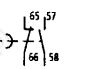
	On-delayed 1 M 1 B	4	4	10		51 42 33	TPE 11 DIL 002279	1 off	
	Off-delayed 1 M 1 B	4	4	10		51 42 33	TPD 11 DIL 002280		
With TÜV* approval to VDE 0116, for fire systems									
	On-delayed 1 M 1 B	4	4	10		51 42 33	TPEH 11 DIL 046924		
	Off-delayed 1 M 1 B	4	4	10		51 42 33	TPDH 11 DIL 046925		

*TÜV = German Technical Supervisory Association

Mechanical latching module

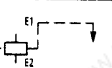
						40 E 31 E 22 E	V DIL (230V 50HZ) 043825	1 off
---	--	--	--	--	---	----------------	-----------------------------	-------

DIL R Contactor Relays

Basic Units, Modules

DC operation		
Type	Price	
Article no.	See Price List	Std. pack
DIL R 40-G (24V DC) 048537		1 off
DIL R 31-G (24V DC) 048532		
DIL R 22-G (24V DC) 048526		
Other actuating voltages → Page 05/024 Contact numbers to EN 50 011 Terminal markings: coil to EN 50 005 DIL R 40: supplied without front plate		
02 DIL 098145		5 off
11 DIL 010345		
20 DIL 012718		
04 DIL 015091		5 off
13 DIL 017464		
22 DIL 019837		
31 DIL 010752		
40 DIL 022210		
Version E combinations correspond to EN 50 011 and are to be preferred; other combinations correspond to EN 50 005		
TPE 11 DIL 002279		1 off
TPD 11 DIL 002280		
TPEH 11 DIL 046924		
TPDH 11 DIL 046925		
V-G DIL (24V DC) 048562		1 off

Notes

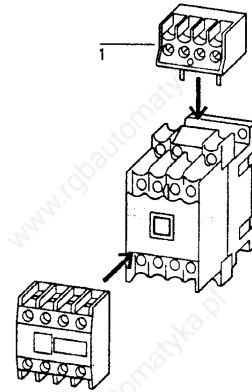

Accessories

Accessories	Page
1 Amplifier module	05/020
Further accessories	05/020

Contactors Relays

Contact Travel Diagrams

The diagrams show the closing and opening travel of the contacts of the contactor relays and auxiliary contacts at no-load. Tolerances are not taken into consideration.

DIL ER-AC



DIL ER-DC

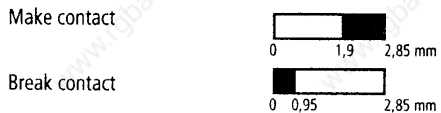

...DIL E



...D DIL E

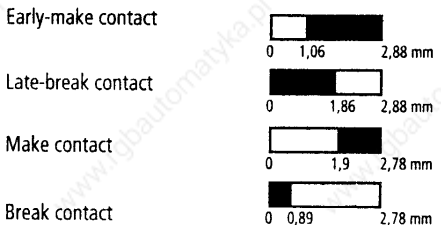

DIL R

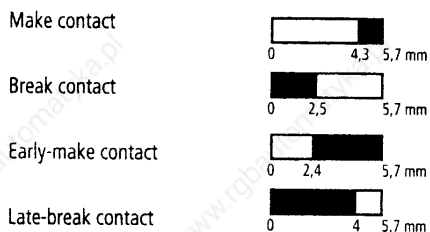

...DIL



TP... 11 DIL

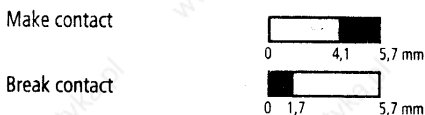

Control Relays, Contactor Relays, Electronic Timing Relays

DIL ER, DIL R Contactor Relays

Technical Data

DIL ER
DIL ER-G
... DIL E

DIL R
... DIL

General

				DIL ER DIL ER-G ... DIL E	DIL R ... DIL
Standards				IEC/EN 60 947, VDE 0660, UL, CSA	
Lifespan, mechanical					
AC operated	Operations	$\times 10^6$	10		20
DC operated	Operations	$\times 10^6$	20		20
Maximum operating frequency, mechanical		Ops./h	9000		7000
Climatic proofing				Damp heat, constant, to IEC 60 068-2-3 Damp heat, cyclic, to IEC 60 068-2-30	
Ambient temperature					
Open	Min./Max.	°C	-25/+50		-25/+50
Enclosed	Min./Max.	°C	-25/+40		-25/+40
Mounting position				As required, except vertical with A1/A2 at bottom	As required except suspended
Mechanical shock resistance					
Sinusoidal shock 10 ms					
Basic unit	Make/break contact	g	10/8		-
Basic unit with auxiliary contact module	Make/break contact	g	10/8		-
Sinusoidal shock 20 ms					
Basic unit	Make/break contact	g	-		10/6
Basic unit with auxiliary contact module	Make/break contact	g	-		10/6
Degree of protection				IP 20	IP 20 (DIL R) IP 00 (... DIL)
Protection against direct contact from front when actuated by a perpendicular test finger (IEC 536)				Finger- and back-of-hand proof	
Dimensions				→ Page 05/037	→ Page 05/038
Weight					
AC operated		kg	0.17		→ Page 18/023
DC operated		kg	0.2		→ Page 18/023
Terminal capacity					
Solid		mm ²	1 × (0.75 - 2.5)		1 × (0.75 - 4)
		mm ²	2 × (0.75 - 2.5)		2 × (0.75 - 4)
Flexible with ferrule to DIN 46 228		mm ²	1 × (0.75 - 1.5)		1 × (0.75 - 2.5)
		mm ²	2 × (0.75 - 1.5)		2 × (0.75 - 2.5)
Solid or stranded		Min.	18		18
		Max.	14		10
Terminal screw			M3.5		M3.5
Pozidriv screwdriver	Size		2		2
Standard screwdriver		mm	0.8 × 5.5		0.8 × 5.5
		mm	1 × 6		1 × 6
Tightening torque	Max.	Nm	1.2		1.2

DIL ER, DIL R Contactor Relays

Technical Data

		DIL ER DIL ER-G ... DIL E	DIL R ... DIL	
Contacts				
Interlocked opposing contacts to ZH 1/457, including auxiliary contact module		Yes	Yes	
Rated impulse withstand voltage U_{imp}		V 6000	8000	
Overvoltage category/pollution degree		III/3	III/3	
Rated insulation voltage U_i		V AC 690	690	
Rated operational voltage U_e		V AC 600	500	
Safe isolation to IEC 536 between coil and auxiliary contacts, and between the auxiliary contacts		V AC 300	440	
Rated operational current I_e				
AC-15	220/240 V	A	6 (4) ¹⁾	6
	380/415 V	A	3 (2) ¹⁾	4
	500 V	A	1.5	1.5
DC-13 ²⁾				
Above 110 V and at $L/R > 15$ ms: it is essential that an arc-quenching device (RC suppressor) be used in parallel with the contacts. C: 1 μ F, R: 0.5 Ω in series				
$L/R \leq 15$ ms: e.g. contactor coils, solenoid valves, DC motors				
Contacts in series:				
2	24 V	A	2.5	10
2 (1)	60 V	A	2.5	10 (6)
3 (1)	110 V	A	1.5	6 (3)
3 (1)	220 V	A	0.5	5 (1)
$L/R \leq 50$ ms: e.g. magnetic clutches, solenoid brakes				
Contacts in series:				
2	24 V	A	–	6
2	60 V	A	–	6
3 (1)	110 V	A	–	3 (1.5)
3 (1)	220 V	A	–	2 (1)
Control circuit reliability $U_e = 24$ V, 17 V/5.4 mA				
Fault probability		H_F	$< 10^{-8}$, < 1 fault in 100 million operations	
Conv. thermal current I_{th}		A	10	16
Component lifespan $U_e = 240$ V				
AC-15			→ Page 05/036	→ Page 05/036
DC-13				
$L/R = 50$ ms: > 2	Operations	$\times 10^6$	0.15	→ Page 05/036
Contacts in series at $I_e = 0.5$ A				
Short-circuit rating when taken directly from mains or transformer > 1000 VA; without welding				
Maximum overcurrent protective device	220/240 V	PKZM 0	4	4
	380/415 V	PKZM 0	4	2.4
Maximum fuse ³⁾	500 V	A gL	6	16
	500 V	A fast	10	–
Current heat loss at I_{th}				
Per contact	AC operated	W	0.2	0.8
	DC operated	W	0.3	0.8

Notes

¹⁾ Auxiliary contact module

²⁾ Making and breaking conditions to DC-13, time constant as stated

³⁾ See transparent overlay 'Fuses' for time/current characteristics (please enquire)

DIL ER, DIL R Contactor Relays

Technical Data

Control Relays, Contactor Relays,
Electronic Timing Relays

			DIL ER DIL ER-G ... DIL E	DIL R ... DIL
Magnet systems				
Voltage tolerance				
AC operated				
Single-voltage coil 50 Hz and dual-voltage coil 50 Hz, 60 Hz				
	Pick-up	$\times U_c$	0.8 – 1.1	0.8 – 1.1
	Dual-frequency coil ... V, 50/60 Hz	Pick-up	$\times U_c$	0.85 – 1.1
DC operated ¹⁾				
	Pick-up	$\times U_c$	0.85 – 1.1	0.85 – 1.1
	Without auxiliary contact module	Pick-up	$\times U_c$	0.7 – 1.3
Power consumption				
AC operated				
Single-voltage coil 50 Hz and dual-voltage coil 50 Hz, 60 Hz				
	Pull-in	VA/W	25/22	67/52
	Sealing	VA/W	4.6/1.3	8.5/2.5
Dual-frequency coil				
	... V, 50/60 Hz at 50 Hz	Pull-in	VA/W	30/26
		Sealing	VA/W	5.4/1.6
	... V, 50/60 Hz at 60 Hz	Pull-in	VA/W	29/24
		Sealing	VA/W	3.9/1.1
	DC operated	Pull-in = sealing	W	2.6
				9.5
Duty factor				
		% DF	100	100
Switching times at 100 % U (approximate values)				
AC operated				
	Closing delay	ms	14 – 21	22
	Make contact	Opening delay	ms	8 – 18
	With auxiliary contact module	Max. closing delay	ms	45
DC operated				
	Closing delay	ms	26 – 35	38
	Make contact	Opening delay	ms	15 – 25
	With auxiliary contact module	Max. closing delay	ms	70

Notes

¹⁾ Smoothed DC or three-phase bridge rectifier required

DIL R Contactor Relays Dimensions

DIL ER... + TD DIL E 24

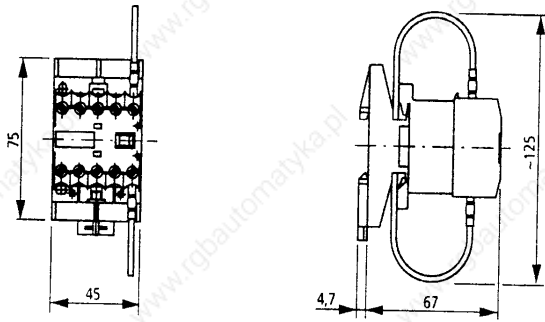

Control Relays, Contactor Relays,
Electronic Timing Relays

Suppressors, amplifier modules

RC B DIL,
FD B DIL
VG B DIL
VS 1(2) DIL

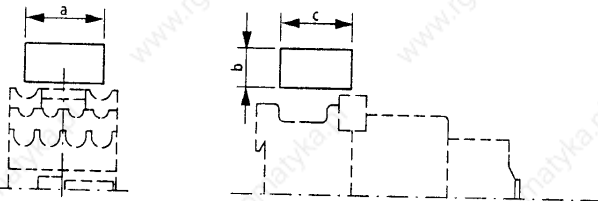

	RC B DIL	FD B DIL	VG B DIL	VS 1 DIL	VS 2 DIL
a	33	33	33	45	45
b	15	15	15	26	26
c	30	30	30	55	55

Contactors relays

DIL R 22(-G)
DIL R 22D(-G)
DIL R 31(-G)
DIL R 40(-G)

DIL R 22(-G) + ...DIL
DIL R 31(-G) + ...DIL
DIL R 40(-G) + ...DIL
DIL R 44D(-G)
DIL R 53D(-G)

DIL R 22(-G) + TPE (TPD) 11 DIL
DIL R 31(-G) + TPE (TPD) 11 DIL
DIL R 40(-G) + TPE (TPD) 11 DIL

DIL R 22(-G) + V (-G) DIL
DIL R 31(-G) + V (-G) DIL
DIL R 40(-G) + V (-G) DIL

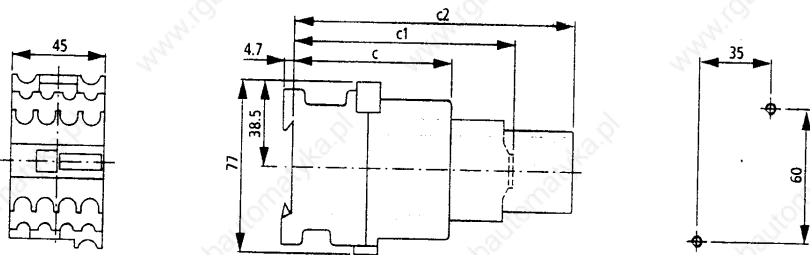

	DIL R 22 (-G)	DIL R 31 (-G)	DIL R 40 (-G)	DIL R 22D (-G)	DIL R 22+...DIL (-G)	DIL R 31+...DIL (-G)	DIL R 40+...DIL (-G)	DIL R 44D (-G)	DIL R 53D (-G)	DIL R 22+TPE11 DIL (-G)	DIL R 22+TPD11 DIL (-G)	DIL R 31+TPE11 DIL (-G)	DIL R 31+TPD11 DIL (-G)	DIL R 40+TPE11 DIL (-G)	DIL R 40+TPD11 DIL (-G)	DIL R22+V DIL (-G)	DIL R31+V DIL (-G)	DIL R40+V DIL (-G)
c (with H DIL)	76,5	(101,5)	-	-	-	-	-	-	-	-	-	-	-	-	-	-	-	-
c (w/out H DIL)	74	(99)	-	-	-	-	-	-	-	-	-	-	-	-	-	-	-	-
c1	-	-	107	-	-	(132)	-	-	-	-	-	-	-	-	-	-	-	-
c2	-	-	-	-	136	-	-	-	-	161	-	137	-	-	162	-	-	-

c1 = With ...DIL auxiliary contact module or DIL R...D (-G) complete unit

c2 = With V (-G) DIL mechanical latching module or with TP...11 DIL pneumatic timer module