

SIEMENS

Equipment for special machines

GRACIS

Interactive Graphics System for Process

Monitoring and Diagnosis with Network Capabilities

Description

Edition 03.94

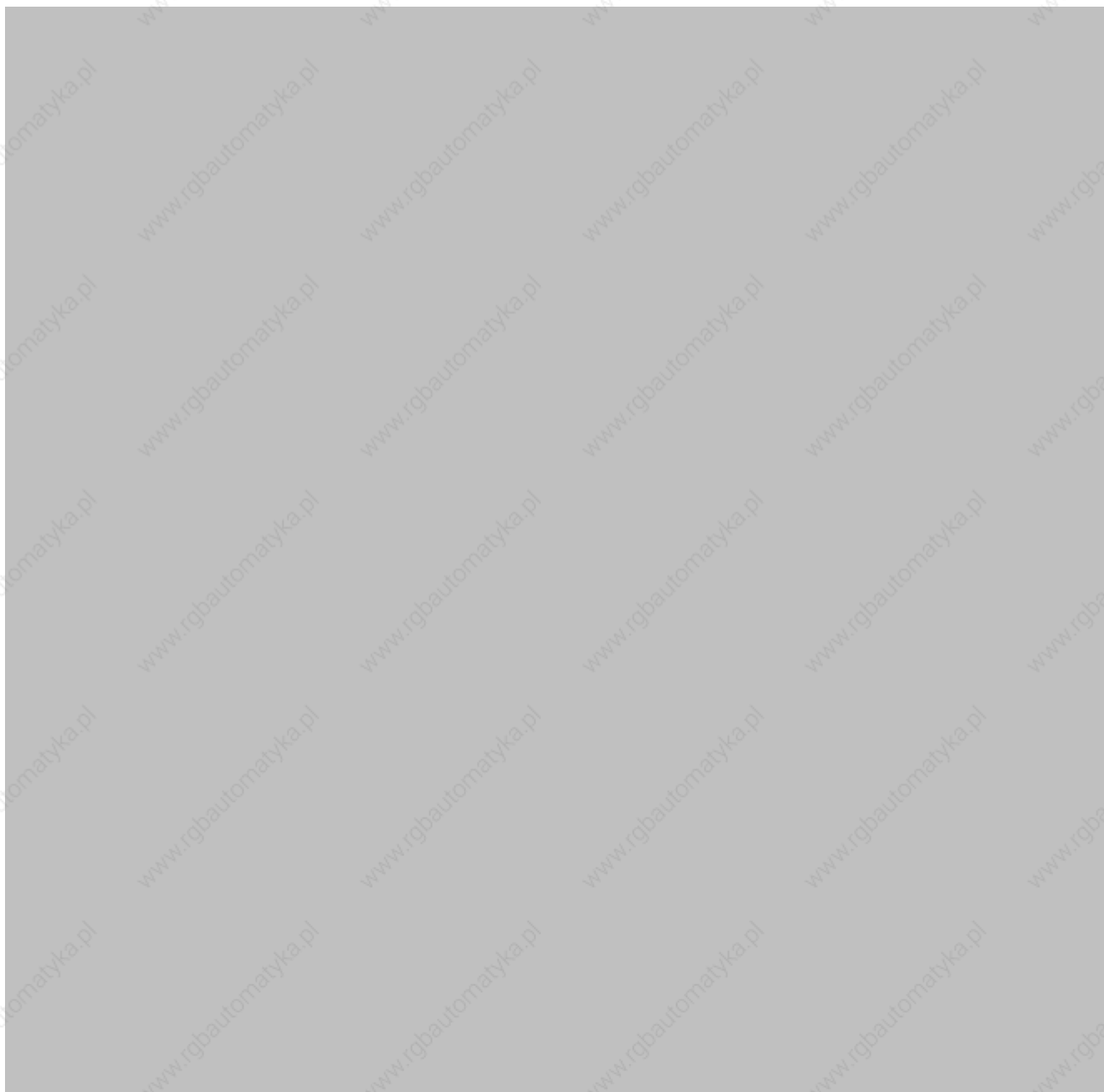

General documentation



Catalog

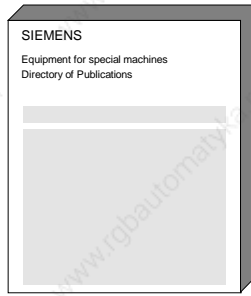

Directory of Publications

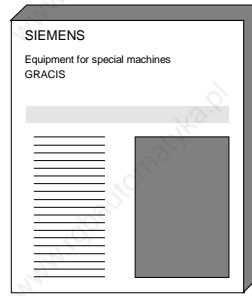

Product brief

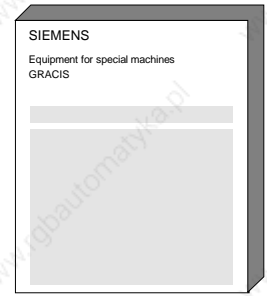

Description

User and service documentation

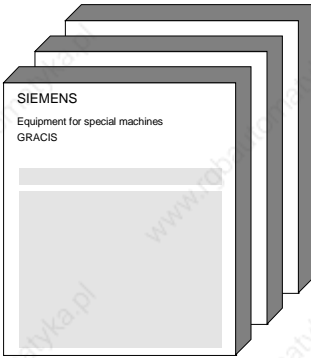

Technical Description

- HPF (Higher Performance)
- LPF (Lower Performance)

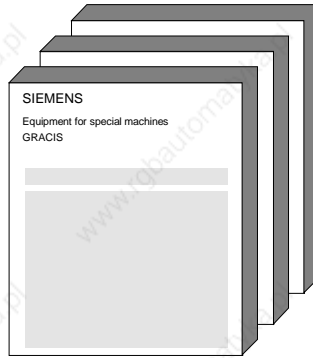

Installation Guide

- SIMATIC S5 Interface (local, H1)
- SIMATIC S5 Interface (L2)
- Process mode

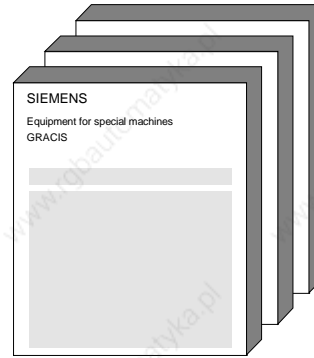

Configuration Guide

- Operator Interface
- Configuration HPF
- Configuration LPF
- Networking
- Options

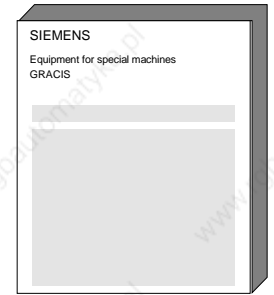

Appendix

Supplementary documentation

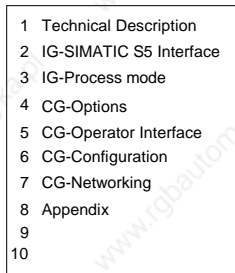

Register - cover page



Reference manual for

- WS 400-30/WS 400-50
- MPs, monitors, keyboards
- IW 30, PC32-F, PC32-X
- VP 30, CP581

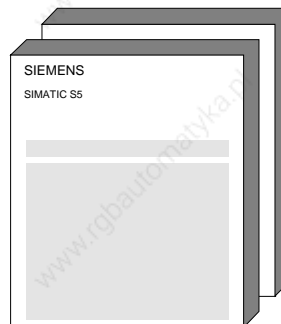

Manual for

- PG 7xx
- S5-115U
- S5-135U
- S5-155U

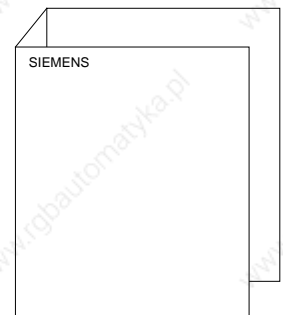

Empty binder

SIEMENS

GRACIS

Interactive Graphics System for
Process Monitoring and Diagnosis
with Network Capabilities

Description

Edition March 1994

Preliminary Remarks **1**

Hardware **2**

Software **3**

Communication **4**

Configuration **5**

Technical Data **6**

Note

Because of clear arrangement, this documentation does not inform about all details of all types of the product. Therefore, it cannot take into account all possible cases of installation, operation and maintenance.

If you require additional information or have special questions, please seek further particulars from your local SIEMENS office.

The contents of this documentation are not part of an earlier or existing agreement, acceptance or legal matter. All obligations by SIEMENS are set in the corresponding sales contract which also contains the complete and exclusively valid settlement. The contract warranty will not be enlarged or limited by this documentation.

Subject to change without prior notice.

The reproduction, transmission or use of this document or its contents is not permitted without express written authority. Offenders will be liable for damages. All rights, including rights created by patent grant or registration of a utility model or design, are reserved.

© Siemens AG 1994 All Rights Reserved

Contents

1	Preliminary Remarks	1-1
1.1	Fundamental Principles.....	1-1
1.2	GRACIS System Environment.....	1-2
2	Hardware	2-1
2.1	Overview.....	2-1
2.2	GRACIS LPF	2-2
2.2.1	GRACIS CP470.....	2-2
2.2.2	GRACIS OP30SM	2-4
2.3	GRACIS HPF.....	2-6
2.3.1	GRACIS CP48x.....	2-6
2.3.2	GRACIS OP40SM	2-8
2.3.3	GRACIS-PG/GRACIS-PC.....	2-10
2.4	Operator Panels, Monitors and Keyboards for GRACIS-S5	2-10
3	Software	3-1
3.1	Configuring.....	3-2
3.2	Message system.....	3-7
3.3	Printout	3-9
3.4	External Memory (only HPF)	3-10
3.5	Access Security Feature / Password Locking (only HPF)	3-10
3.6	GRACIS Network Management (GNM).....	3-10
3.7	Centrale Function Control ZFS (only HPF).....	3-11
3.8	Service module.....	3-12
3.9	Pixel Graphics (only HPF)	3-13
3.10	System Texts in Russian	3-13
3.11	Process Simulation.....	3-13
3.12	User Interface GRAPI (only HPF).....	3-13
3.13	WFGRAKO	3-13
3.14	Diagnosis Journal (only HPF).....	3-14
3.15	Display of GRAPH 5 Sequence Chains.....	3-15
3.16	Modification Journal (only HPF).....	3-16
3.17	GRACIS NC-Data Management.....	3-16

3.18	Standard B-GRACIS	3-17
3.19	Tool and Recipe Management	3-18
3.20	Form and Scope of Delivery	3-19
4	Communication	4-1
4.1	GRACIS-S5 - SIMATIC S5	4-1
4.2	Communication GRACIS-OP - SIMATIC S5	4-1
4.3	Communication GRACIS SINEC H1/L2	4-2
5	Configurations	5-1
6	Technical Data	6-1

1 Preliminary Remarks

1.1 Fundamental Principles

Due to the increasing complexity and performance of machine tools, production lines and production plants, their economy depends more and more on the quality of the process operating and visualization system. To reduce machine downtime and avoid interruptions of the production process, faults must be detected early and their reasons eliminated quickly and safely.

The networked visualization system for interactive process monitoring and diagnosis GRACIS® (**GRA**phic **C**omputer **I**ntegrated **S**upervising) has been developed in view of the following requirements.

- **Modularity**
Thanks to the subdivision into a lower and a higher performance field as well as the possibility of extending the system through options, GRACIS can be adapted to any job. The hardware can freely be selected: SIMATIC S5 module, operator panel or PC/PG.
- **Flexibility**
With GRACIS, you may configure the system in your office, away from the plant. Configuring is, however, also possible parallel to process operation. GRACIS can be used as a stand-alone system or within a network.
- **Openness**
Via the user interfaces, you can integrate your own programs into GRACIS.
- **Compatibility**
All GRACIS systems have the same configuring. The created data/displays can be used in the lower and in the higher performance field. WF470 displays can be converted into GRACIS displays.
- **Ease of operation**
The comfortable operator environment with extensive help functions considerably facilitates configuring. GRACIS can be operated from any station.
- **Economy**
Due to the subdivision of hardware and software into modular packages, a GRACIS solution can be configured for the customer's specific job. The operator can inform himself continuously about the most important data of the plant and, therefore, recognize critical developments at an early stage. The integrated diagnosis helps to localize errors quickly. Standard screen forms for technology modules guarantee short conversion times.

1.2 GRACIS System Environment

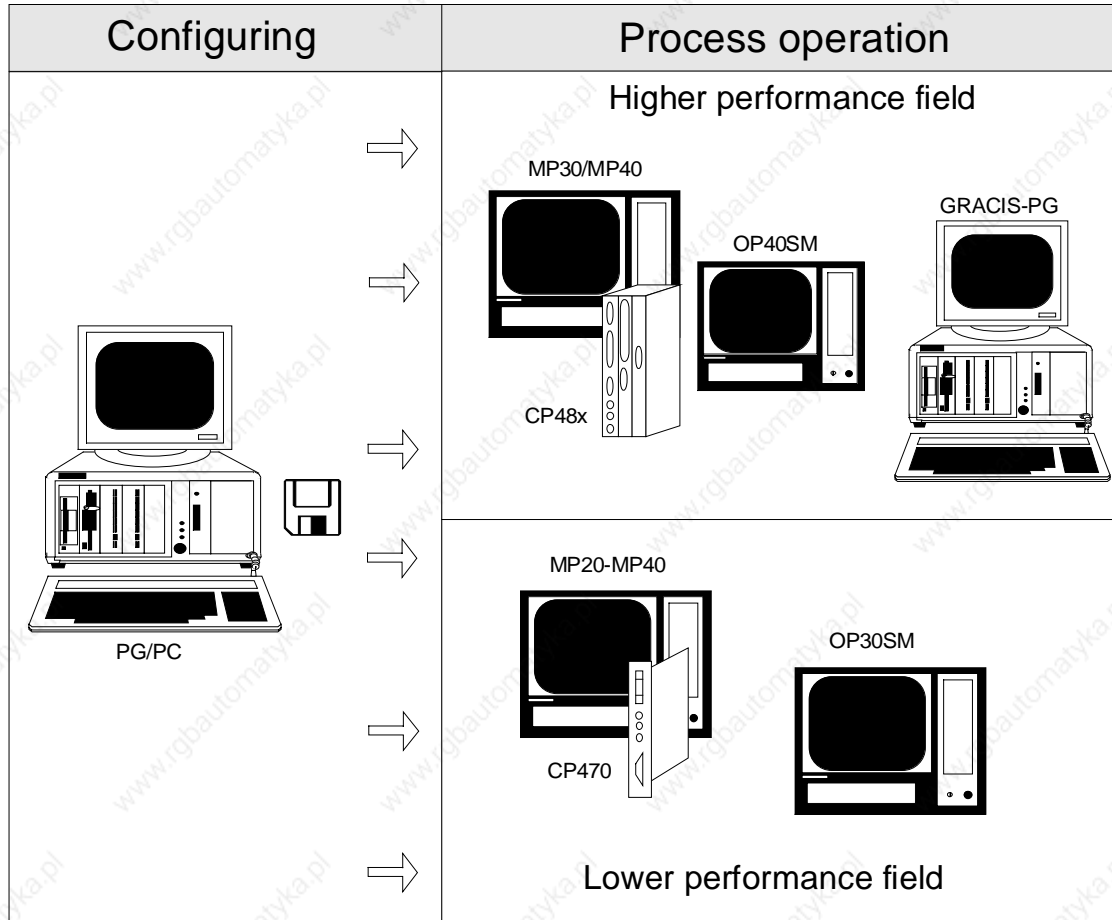

Fig. 1.1 System environment

Performance fields

GRACIS is offered in 2 performance fields. The lower performance field is particularly suited for simple, machine-related applications. The higher performance field with its openness, parallel PG functions and on-line configuring, is the solution for more sophisticated jobs.

Configuring is identical in both performance fields. The created displays run in both performance fields. In both fields, GRACIS offers two hardware variants: the intelligent operator panels (OP) as stand-alone systems and the communication processor modules (CP) as communication processors for the SIMATIC S5. Monitor panels or individual monitors with keyboard are used as operating and display devices for the CP's.

Configuring / process operation

To configure the displays, a fully graphical user environment with numerous editing and copying functions is available. The modern and comfortable configuring environment offers, among others, windowing technique, mouse assistance, pop-up and drop-down menus.

In process operation, the previously configured displays are connected with the data sources and targets. GRACIS collects data from the SIMATIC S5 via SINEC H1, SINEC L2 or via the serial interface and visualizes them in the configured displays. It is also possible to transfer operator inputs to the process.

Local solution

For visualization tasks of stand-alone machines, GRACIS can be used as a local solution, either as a module with monitor panel or as an operator panel (serial connection to the PLC).

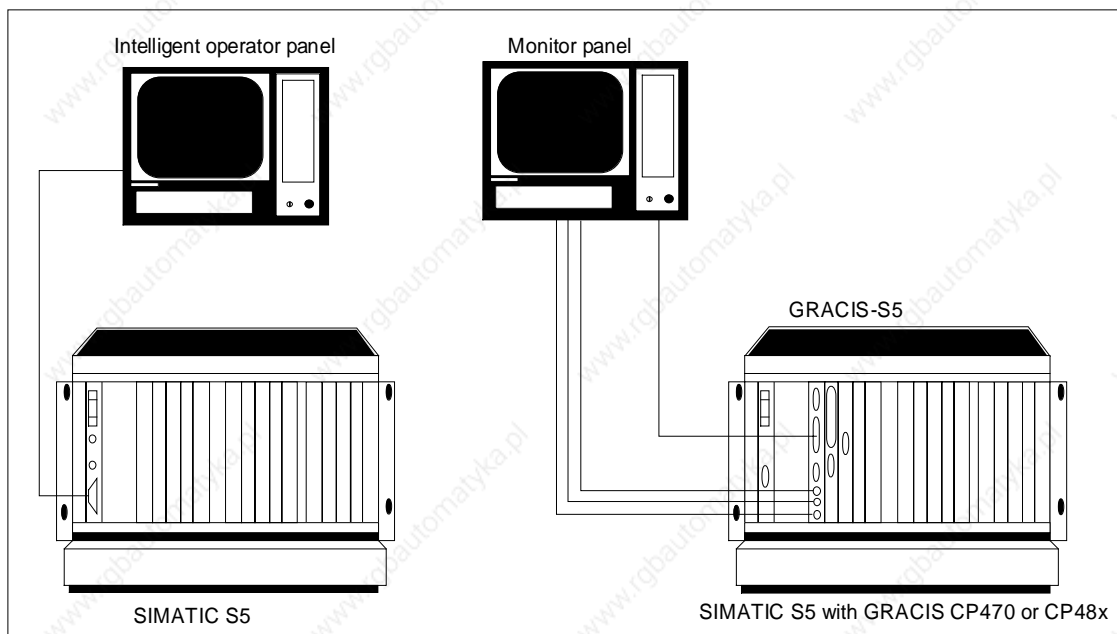

Fig. 1.2 Local visualization as OP or CP

Networked solution

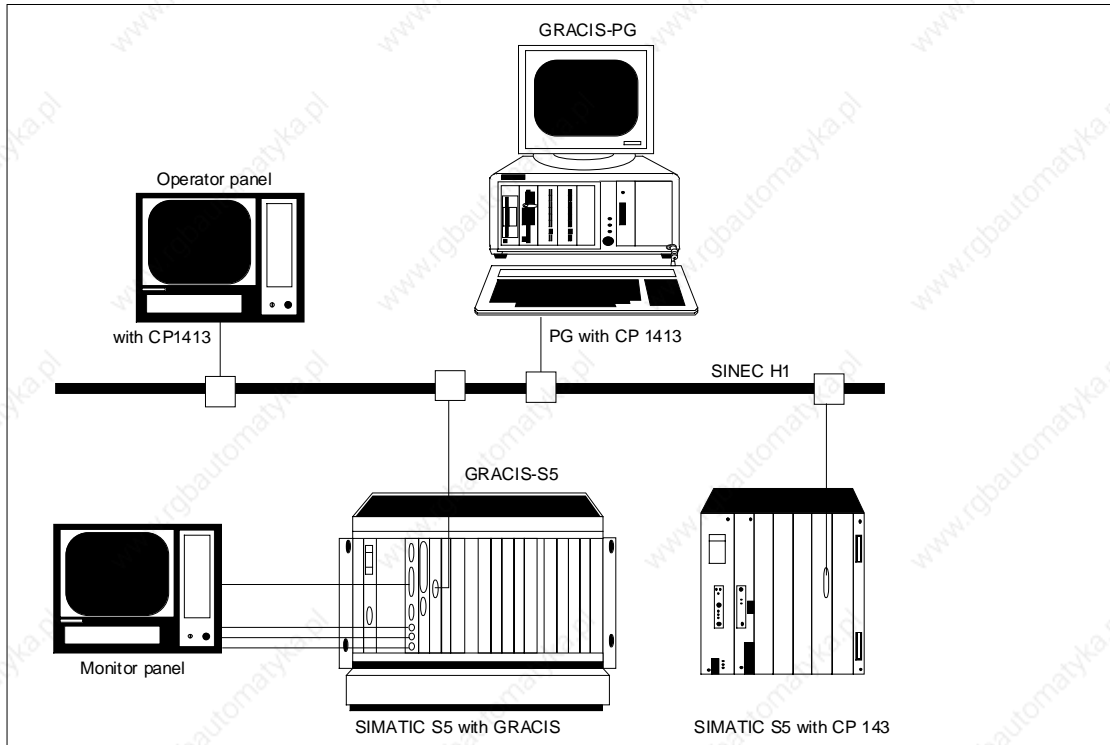

Fig. 1.3 Networked visualization (example)

Structure and functionality of GRACIS permit a network-wide communication between the controls of the single-user systems directly via the SINEC H1 or SINEC L2 bus systems. The multi-level hardware and software concept supports the implementation of the different control structures.

The GRACIS network may also include systems without GRACIS module, e.g. a SIMATIC S5 with network connection via CP143 or CP5430 or a SINUMERIK 880 with CP231A.

Compatibility

Displays created for the GRACIS WF 48x modules are fully compatible with GRACIS HPF.

Displays created for WF 470 can be converted with the conversion program WFGRACO (see chapter 3) into GRACIS format.

2 Hardware

2.1 Overview

The main features of the individual hardware components are described in this chapter.

GRACIS LPF

CP470 Inrack module with firmware on EPROM; as user memory, battery-buffered SRAM cards with different capacities are additionally available. The data are transferred via the SIMATIC S5 backplane bus.

OP30SM The intelligent operator panel is serially connected to the SIMATIC S5 via the PG interface. It contains the firmware on EPROM as well as 256 kB flash EPROM for user data. For extensive user data, additional memory modules are available. The operator panel is available in the variants monochrome with EL display and with colour LCD display (TFT).

GRACIS HPF

CP485 Basic module with 8 MB RAM and mass memory module (hard disk and floppy-disk drive). The process operation software is included in the delivery, on hard disk.

CP486 The CP486 has, in addition to the CP485, a slot module for connection to SINEC L2 or SINEC H1.

OP40SM The intelligent operator panel OP40SM looks like the colour LCD version of the OP30SM, but is additionally equipped with a hard disk and a floppy-disk drive and possesses 10/16 MB RAM. The OP40SM is available with three different processors. The device is supplied with pre-installed process operation.

2.2 GRACIS LPF

The communication processor CP470 is the advancement of the WF 470 on the basis of a new, fully graphic hardware. The CP470 functionality is also available in the stand-alone version OP30SM.

2.2.1 GRACIS CP470

The communication processor CP470 is a flat module in double European format and occupies one SIMATIC S5 slot. It can be used in the following devices:

- PLC S5-115U: with CPU 941 B, 942B, 943B, 944B, 945 (only with adapter casing)
- PLC S5-135U: with CPU 928A, 928B
- PLC S5-155U: with CPU 928A, 928B, 948
- EG 185 U
- CR 700-2
- CR 700-3
- ER 701-3 (not with interface 311)

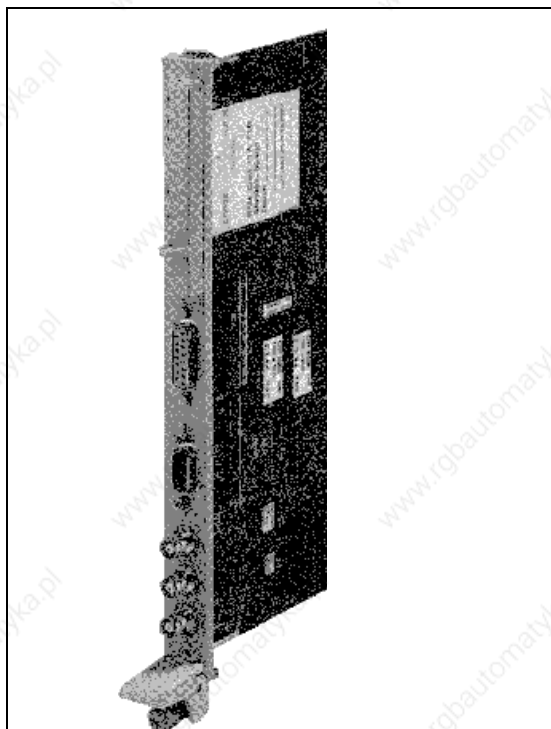

Fig. 2.1 CP470

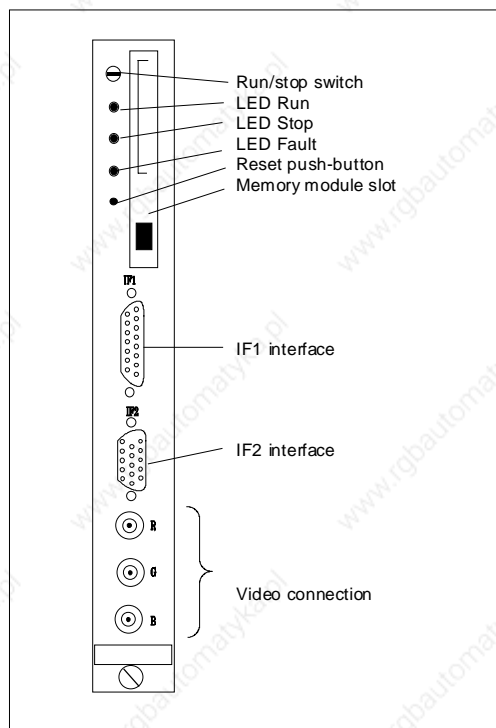

Fig. 2.2 Front view of the CP470

Run/stop switch

This switch controls the two operating modes STOP and RUN. Position RUN (process operation) provides an unrestricted operation. Position STOP prevents data exchange with the PLC.

Interfaces IF1 and IF2

Via the two 15-pole connectors IF1 and IF2, keyboard and printer or a programmer can be connected. The programmer is always connected to IF1.

In operating and observing mode, the keyboard must be connected to IF1 and a printer to IF2. The printer interface can be operated as a V.24 interface or a TTY interface.

Memory

The GRACIS process operation software is on 2 EPROM's. Furthermore, the CP470 possesses a 512 kB DRAM as main memory and its own graphic processor (TMS34010) with video RAM's as display memory.

For the configuring data, the CP470 offers as user memory so-called memory cards (SRAM-buffered) of different capacity (512 kB, 1 MB, 2 MB). The memory modules of the CP470 (SRAM) contain all user programs needed for the creation of displays as well as the pertaining management information. The SRAM cards are centrally buffered via the backplane bus of the PLC. Even if the card or the entire module is withdrawn, the user programs will not be lost. The data are buffered through a battery integrated in the card.

Programming of EPROM, flash EPROM or OTP cards is not supported on the CP470.

Printer connection

The printer is always connected on SS1. The following printers can be connected: DR 210-N, DR 211-N, DR 230-N, DR 231-N (each with IBM module) and GRACIS-Printer.

For hard copies of the process displays in configuring operation, a GRACIS-Printer (HP-Printjet) can be connected. With GRACIS HPF, hard copies can also be made in process operation.

2.2.2 GRACIS OP30SM

The operator panel OP30SM is available in 2 versions:

- OP30SM/EL with luminous electroluminescence display
- OP30SM/LCD with TFT colour LCD

Both versions are equipped with touch-sensitive keyboard. The front panel is with protection class IP65.



Fig. 2.3 Front view of OP30SM

The OP30SM consists of:

- protective cover with ventilation slots and opening for the connections (see below),
- front panel, with display (EL or LCD) and 2 touch-sensitive key modules and
- internal electronics.

Below the display, there are 16 function keys with LED. The operating-key module contains 40 keys (16 of them with LED), the operating-voltage display and the key-operated switch.

The OP30SM is at choice available with 2 fixed direct-key modules (DTM) (F9-F12 and F13-F16 each). Each module provides 4 potential-free, short circuit-proof 24 V outputs (external voltage supply). An output is occupied as long as the associated key is depressed (inching service).

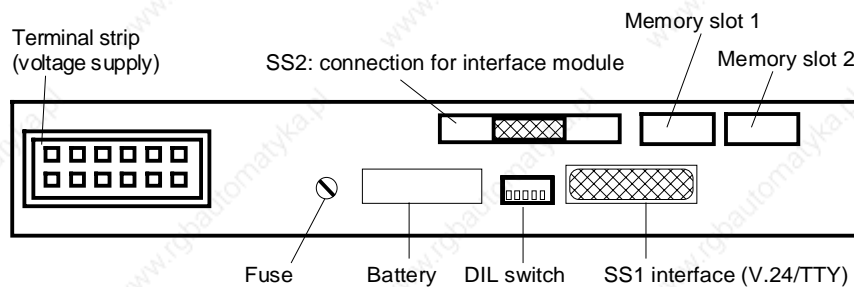

Fig. 2.4 OP30 connection elements

SS1 interface

The V.24 and the TTY interface signals are applied on this interface. A programmer, a PLC or a printer can be connected here.

SS2 interface

For printer operation, an interface module for coupling the OP30SM (printer to SS1) with the PLC or with the SINEC L2 (in prep.) can be inserted. For the time being, a serial interface module for the transmission modes V.24 (RS 232) and TTY (20 mA) can be plugged in.

If you want to use in addition the printout function or the mains connection via SINEC L2 (in prep.), you have to insert either the serial S5 module or the L2 module. The printer is in that case connected to SS1.

Memory

The memory slot 1 is always occupied by the memory module 1 (included in the delivery). This module contains the process operation software and 256 kByte flash EPROM for configuring data.

For configuring data over 256 kB a second memory module with a capacity of 256 kB, 512 kB or 768 kB can be plugged in the memory slot 2.

Printer connection

The printer is always connected on SS1. The following printers can be connected: DR 210-N, DR 211-N, DR 230-N, DR 231-N (each with IBM module) and GRACIS-Printer.

For hard copies of the process displays in configuring operation, a GRACIS-Printer (HP-Printjet) can be connected. With GRACIS HPF, hard copies can also be made in process operation.

Coupling

The OP30SM can serially be coupled via the PG interface with the following programmable logic controllers via the AS511 printout:

- PLC S5-90/PLC S5-95
- PLC S5-100U: CPU 100, 102, 103
- PLC S5-115U: CPU 941B, 942B, 943B, 944B, 945
- PLC S5-135U: 928A and B
- PLC S5-155U: CPU 948

2.3 GRACIS HPF

The functionality of the higher performance field is also offered on 2 hardware versions: communication processors CP48x and operator panel OP40SM.

2.3.1 GRACIS CP48x

The modules CP485 and CP486 constitute the continuation and advancement of the GRACIS system on the basis of the WF 48x modules. A new, low-price hardware basis was used for them and the software adapted accordingly and extended with new functions. The CP485 consists of the basic module and the mass memory module. Its field of application is the local visualization. The CP486 is in addition equipped with a slot module with CP5410 interface for SINEC L2 or CP1413 for SINEC H1 for networked visualization.

The system memory of 8 MB RAM is located on the basic module. The mass memory module is provided with a 2.5" hard disk with 120 MB and a 3.5" floppy drive (1.44 MB). The GRACIS process operation basic software package is in the standard version pre-installed on the hard disk.

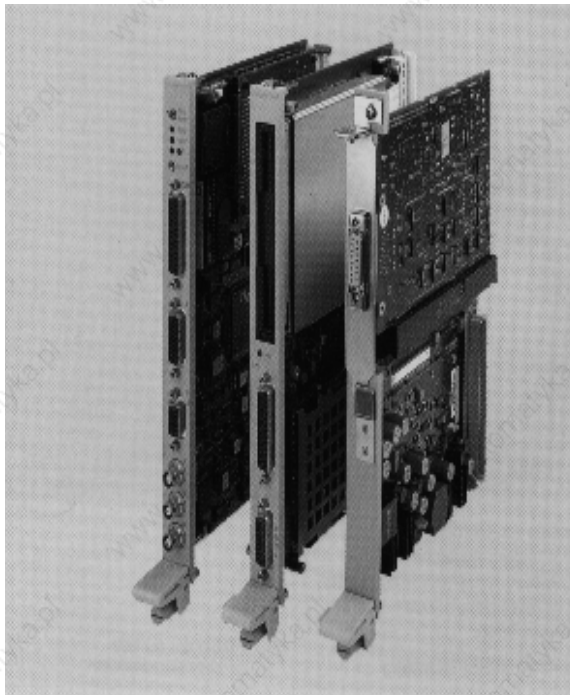

Fig. 2.5 CP48x

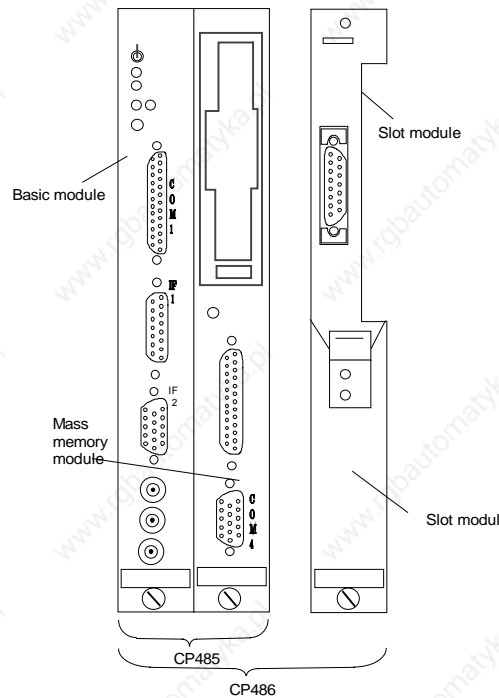

Fig. 2.6 CP48x front view

The CP48x can be used in the following devices.

- PLC S5-115U module racks CR700-0LB and CR700-3 (only with adapter casing): with CPU 941, 942, 943, 944, 945
- PLC S5-135U: with CPU 928
- PLC S5-155U: with CPU948
- EG 185 U: with IM 304/314 or IM 307/317

Operating and display elements

The operating and display elements are arranged on the front panels of the basic modules and of the mass memory modules.

Operating mode switch	With this switch, the operating modes <i>RUN</i> and <i>STOP</i> are preset. The <i>RUN</i> mode provides unrestricted operation of the modules. For normal operation, the switch must be in position <i>RUN</i> . Position <i>STOP</i> prevents the data exchange with the programmable logic controller.
RESET push-button	By pressing the RESET push-button, you abort all programs running, and the operating system is newly loaded. The RESET push-button can only be actuated when the operating mode switch is in position <i>STOP</i> .
Displays	The two LED's <i>RUN</i> and <i>STOP</i> indicate the current status of the module. The error display S5 indicates an error in the SIMATIC S5 interface. The error display HW indicates hardware errors. The access display lights up when the hard disk is accessed. The access display lights up when the diskette is accessed.

Interfaces

Serial printer	COM1: TTY/V.24 COM4: TTY/V.24 via adapter
Parallel printer	LPT1: TTL
Mouse:	IF1: V.24 via Y-adapter IF1: V.27 via RTI (Remote Terminal Interface)
Monitor panel keyboard	COM4: TTY
Process operating keyboard	IF2: X.27
PG keyboard	IF1: V.27 via adapter with round bushing
Monitor/monitor panel	R,G+S,B midi coaxial cable
S5-CPU	COM1: TTY
Network connection	The slot module on the CP486 permits the use of a short AT slot assembly: - CP5410 for connection to SINEC L2 - CP1413 for connection to SINEC H1

2.3.2 GRACIS OP40SM

The operator panel OP40SM is an intelligent, compact operating and diagnosis station. With a mounting depth of only 125 mm it is designed for cabinet or desk mounting; the front panel of the housing is with protection class IP65.



The front panel of OP40SM is identical with that of OP30SM.

Thanks to the use of an AT CPU motherboard, the device is a PC-compatible computer with an 85 MB hard disk drive, internal 3.5" floppy drive and VGA card.

Fig. 2.7 OP40SM with GRACIS process operation

The CPU is available in 3 versions:

- 80386SX/25MHz with 10 MB RAM
- 80486SX/25MHz with 16 MB RAM
- 80486DX/33MHz with 16 MB RAM

The GRACIS process operation basic software package is in the standard version pre-installed on the hard disk.

With the exception of the MF2 keyboard connection on the front panel, all interfaces are accessibly from below at the shoulder on the rear of the device.

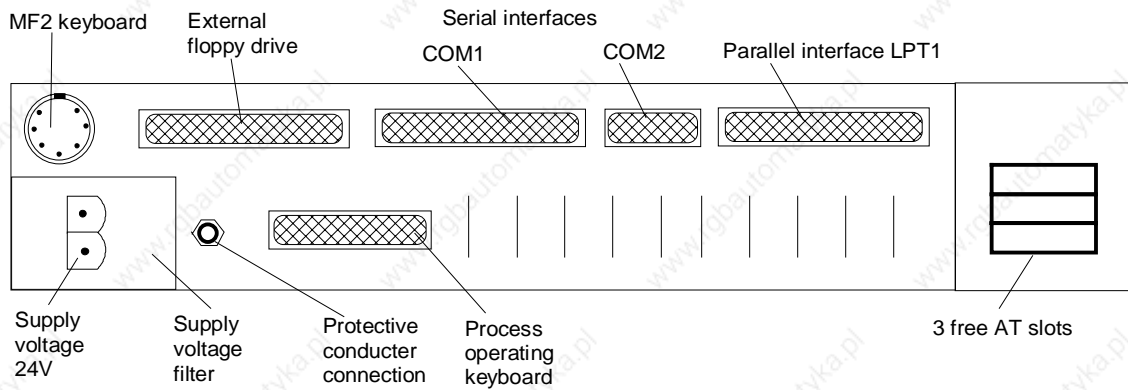

Fig. 2.8 OP30 connection elements

Front panel

The front panel consists of base frame and cover frame. It contains the protective plate of the display, the operating module and the function-key module.

Function-key module	16 function keys (F1-F16) freely assignable by the user, with LED's.
Operating-key module	- 40 keys (16 with LED) with full ASCII character set - Operating-voltage display - 1 key-operated switch - 1 round bushing for connection of an external MF2 keyboard

Interfaces

SIMATIC S5-CPU	COM1: TTY
Serial printer	COM1: TTY/V.24 COM4: TTY/V.24 via adapter
Parallel printer	LPT1: TTL
Mouse	COM2: V.24
Monitor panel keyboard	COM4: TTY
Process operating keyboard	IF2: X.27/V.24
MF2 keyboard	Round bushing: TTL
External diskette drive	37-pole TTL
Network connection	The OP40SM is equipped in standard version with 3 free AT slots for the use of short AT slot assemblies: - CP5410 for connection to SINEC L2 - CP1413 for connection to SINEC H1

2.3.3 GRACIS-PG / GRACIS-PC

The programmers PG 730, PG 750 and PG 770 or a PC are also suitable for the application of GRACIS. GRACIS-PG/PC can be used as a separate configuring station or can be integrated into the GRACIS network.

Minimum requirements: as from 80386/25 MHz, 8 MB RAM and 50 MB hard disk memory as well as a 3.5" diskette drive. Recommended and tested PC's:
SIEMENS SICOMP PC32-D/G/R/T and SIEMENS NIXDORF PCD-4G/4NCsl.

Siemens does not assume any warranty for running GRACIS on other PC's. The compatibility list is, however, permanently extended.

2.4 Operator Panels, Monitors and Keyboards for GRACIS-S5

Monitor panels (compact units with screen and keyboard) or individual monitors and keyboards are used as input/output devices for the CP versions.

You can connect the monitor panels MP20 (only CP470), MP30 or MP40. The uniform layout of the operator panels offers 16 function keys and 40 operating keys (32 of them with LED's, in case of MP30).

The individual monitors that can be connected are OM36, OM51, PM36 and PM51 in various versions:

- Desk-top versions in office execution (IP20) with screen diagonal 36 cm or 51 cm
- Industrial execution, diagonal 36 cm: desk-top version IP30 or built-in version (IP54 or IP65, resp., on the front panel)
- Industrial execution, diagonal 51 cm: desk-top version IP30 or built-in version (IP54 on the front panel).

The following keyboards can be connected: PBT20 and PBT40 in office execution (IP20) or industrial execution (IP54), with alphanumeric keypad (54 keys), 16 function keys, cursor block of 10 keys and numeric keypad of 12 keys.



For further technical data of monitor panels, keyboards and monitors, see catalog ST80.1 or 80.3.

3 Software

The GRACIS function packages are based on multitasking real-time operating systems. A multitasking operating system is characterized by the fact that it can process several programs (function packages) simultaneously. A real-time operating system guarantees quick response to the events occurring. For example, the message system is active in the background and indicates all events on the screen, even if the operator is in the configuring mode.

Part of the GRACIS function packages communicate directly with the operator via the screen (e.g. process display editing, messages, diagnosis). Another part works exclusively in the background (e.g. printouts, external memory function).

In the higher performance field, configuring may run on the target device, in the lower performance field, configuring has to be effected on a configuring station and the displays created are then loaded into the target device.

In configuring mode, the displays, printouts, messages and texts are created and stored in the GRACIS system.

In the process operation mode, you select for example displays, enter data for the SIMATIC S5 or output printouts on the printer. Texts and process values of a running plant are linked with process displays, printouts and messages.

The variables of the displays, printouts and messages whose source or target are located in the SIMATIC S5 are updated in the parameterized updating time reference. For this purpose, the SIMATIC S5 CPU must be in the RUN state and connected on-line with the GRACIS system.

Process operation is possible in process displays or in the option packages (service module, GRAPH 5 diagnosis, etc.).

In process operation, the operator may change displays, open and close windows, enter data, output hard copies or printouts, and work with message fields.

As compared with the lower performance field, the higher performance field offers in addition:

- Networking
- Configuring and process operation on the same hardware
- Possibility of several windows
- Triggering of additional actions via active fields
- Possibility of additional options (see also "Form of delivery")

3.1 Configuring

A process display is the symbolic representation of a plant, a process, etc. In addition, values can be input and output. Conditions which are important for the process can be visualized, so that the plant can easily be observed and operated with the help of the process display.

In configuring mode, process displays are created and the links with the real process are defined.

The process displays, messages and texts are programmed via the dialog-oriented operator environment with menu and window technique, supporting an operation via keyboard, operator panel and mouse.

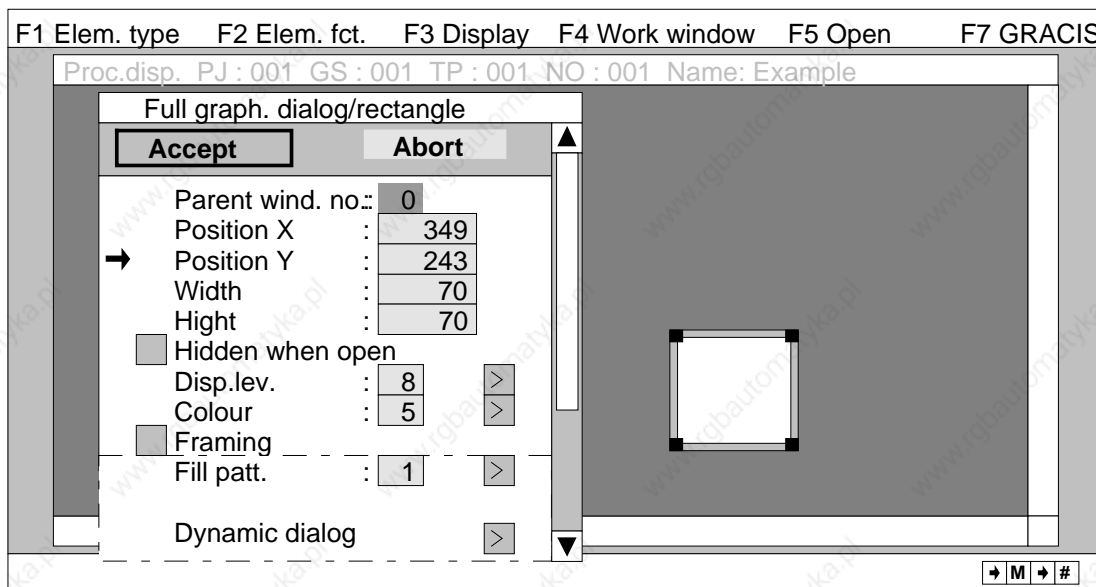

Fig. 3.1 Configuring

Structure of process displays

Process displays consist of different element types. The individual display elements like curves, bars, etc. can be provided with static as well as dynamic attributes. Process connection is effected directly on the object.

In the higher performance field, you can work with several windows. To guarantee a defined overlapping behaviour when opening windows or moving elements, GRACIS possesses 15 display levels, so that e.g. the most important window is always visible, even if later on, a second window is opened in the same place.

The dynamic performance of a display element is divided into direct and indirect dynamic performance.

- In direct dynamic performance, a display element possesses itself a dynamic behaviour:
 - Displacement relative to its position of creation
 - Change foreground/background colour
 - Reveal/hide
 - Rotate
 - Exchange symbols
- In indirect dynamic performance, the change of a process value triggers an action which does not change the current display element. Such an action can be the revealing of a window or the start of a printout.

Process values can be represented as follows:

- Alphanumeric display in the variable field
 - Alphanumeric
 - Binary-coded absolute number
 - BCD
 - Hexadecimal representation
 - Representation as bit pattern
 - Fixed-point number
 - Floating-point number
 - S5 format KY
- Graphic representation
 - Bars with or without colour changeover
 - Data acquisition block by block and representation as a curve
 - Recorder function, continuous updating

The process values can be updated as follows:

- Once upon opening of the display
- Periodically in the display time reference
- Periodically in the window time reference
- Periodically in the element time reference

For creating displays, a great choice of elements are available:

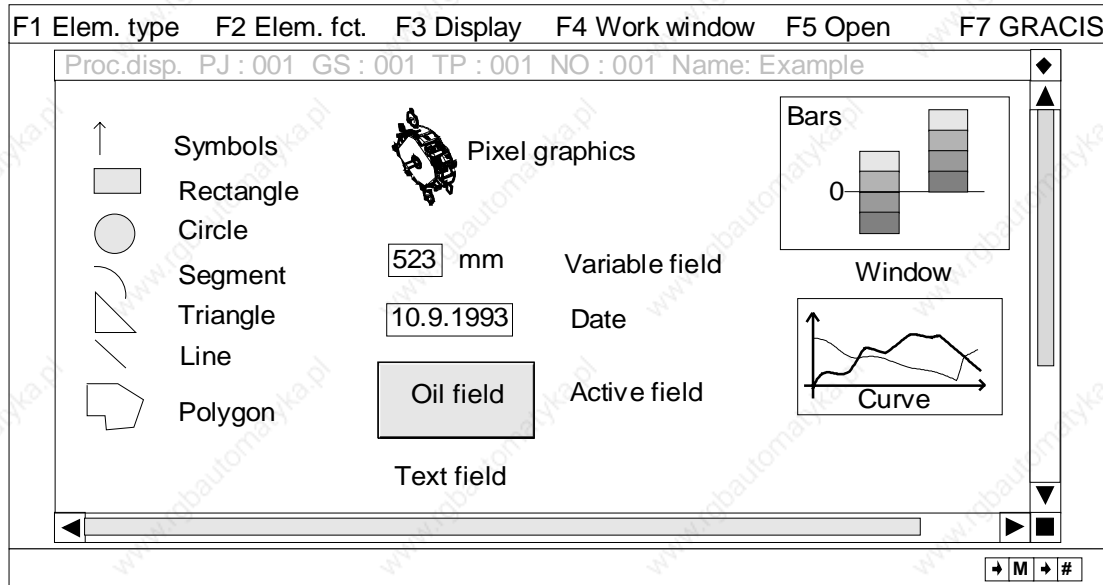

Fig. 3.2 Display elements

Variable fields

A variable field (V-field) is a rectangular display space for alphanumeric representation or input of process values. The data source or data target of the SIMATIC S5 controller or a GRACIS-internal data block as well as the input/display format are assigned to a V-field. The dynamic performance of the display space for variables can also be configured (reveal/hide, displace, etc.).

Full graphic elements

Basic geometric shapes are available for creating complex display parts, such as machines or control schemas.

Curves

A curve is the graphic representation of process values. The curve is updated either upon creation of the display, at fixed time intervals or continuously via a recorder function. Each curve window can contain 5 curves at a time. Furthermore, the course of limit values can be displayed with static curves.

Bars

A bar is a rectangular surface whose size analogously describes a digital value. This value is usually the value of an allocated process variable. The process value is displayed in percent of its maximum value. Bars can be divided into percent zones with different colours. The bar can change its colour in the new zone or as a whole. Different growth directions can be configured.

Symbols (only HPF)

In the higher performance field, you may select symbols from 2 symbol sets (of 256 symbols each).

Character set

The lower performance field disposes of a system character set with type sizes 7, 10, 14, 20 pixels. The higher performance field has an additional character set, offering in addition the type sizes 38, 40 and 56 pixels.

Text field

A text field is a rectangular display space with static text. This text serves for inscribing process displays. The number of characters available depends on the selected character set. Within one text field only one of the available character sets in the different type sizes is valid.

Message text field

The message text field displays process statuses by revealing texts or by changing text attributes. The messages are derived from status changes of the process signals. The texts and the linking of the texts with the process statuses can be configured.

Aktive fields

Aktive fields are elements through which actions can be triggered in process operation.

Actions triggered by

- Any key
- Mouse/light pen (HPF)
- Cursor + Return
- "Bit" from SIMATIC S5

Actions

- Deselect display
- Change display
- Trigger printout function
- Acknowledge V-field group
- Transfer constant to controller
- Select sequence list
- Abort V-field group
- Transfer field ID to GRAPI
- Reveal/hide display elements
- Functions for curves (HPF)
- Operation of message system (HPF)
- Operation of GRAPI functions (HPF)
- Copy data (HPF)
- Start hard copy (HPF)
- Group acknowledgement for message fields (HPF)

Disable functions

- By key-operated switch
- By password (HPF)

Element network

Several of the above-mentioned elements can be combined in a network. A network can be processed in the same way as a single graphic element.

V-field group

Variable fields can be combined in groups. The values input in the individual V-fields of the group are buffered by GRACIS and transmitted to the SIMATIC S5 only after acknowledgement, so that values depending on one another are always stored together. When an input is aborted, the input for the whole group will be aborted.

3.2 Message System

The message system serves for quick display of faults and their reasons. The message system enables an immediate and precise error diagnosis and an analysis of the order of messages occurred. GRACIS manages these messages in message lists. Structuring is effected in message lists, to each of which a message buffer is assigned. Each message list can contain up to 4096 messages.

The triggering of a message can be parameterized network-wide. Trigger conditions are binary signals or limit-value violations. When a message is triggered, GRACIS stores the message line in the associated message buffer. The message system outputs these pending messages priority-controlled.

You may furthermore configure whether GRACIS monitors the trigger conditions or whether monitoring is done in the SIMATIC S5 and signaled by the central function control (ZFS) to GRACIS. Triggering messages by means of the ZFS is useful in particular in case of a large number of possible trigger conditions, as less processing time of the GRACIS system and of the bus system is taken.

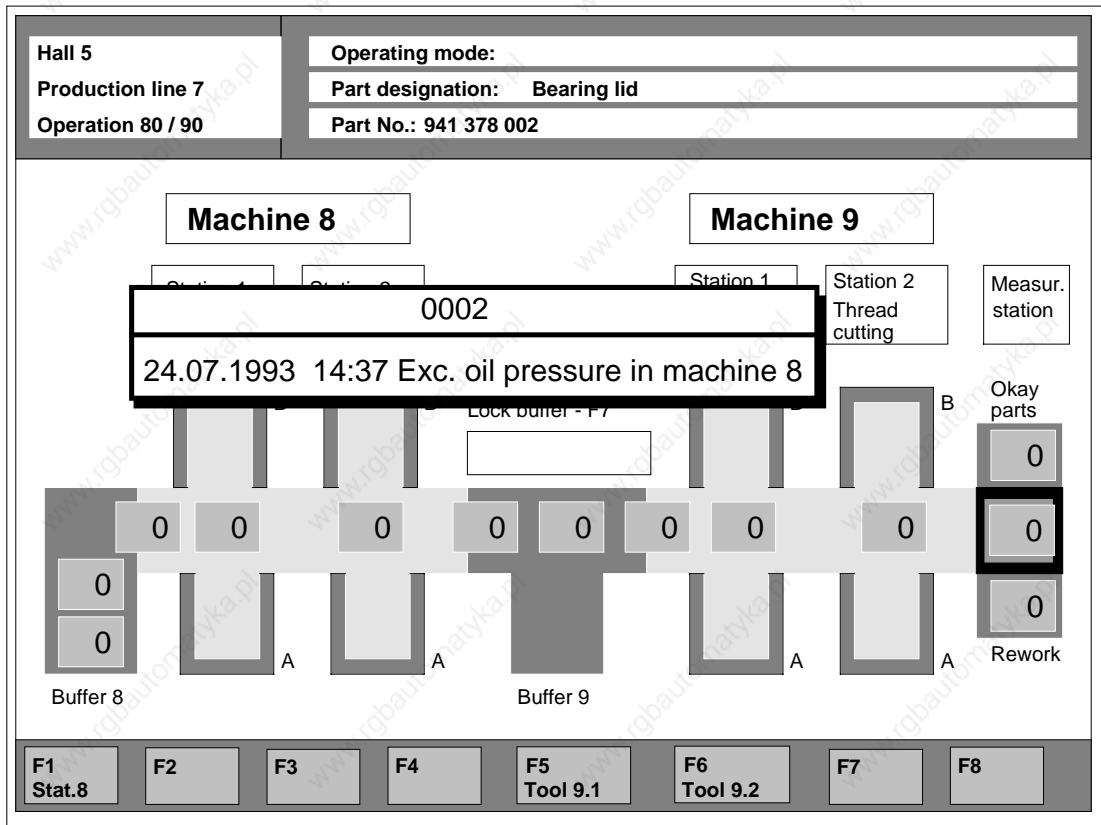

Fig. 3.3 Message system

A message consists of one line and is freely configurable with:

- Date
- Time
- ID: "Incoming message", "Outgoing message", message type (HPF)
- Message length
- Message class, message ID (HPF)
- Data source (HPF)
- Process variable fields (max. 16 fields) (HPF)
- Texts from the text lists
- Number of messages since start of the message system (HPF)

Outputs are made to:

- Printer
- Message field

The size of the message field is freely configurable. The message field displays messages in process operation.

Global message window (only HPF)

The global message window serves for display of messages, independent of the currently open display or the console (e.g. configuring, PG functions), in which the GRACIS system is at the moment when the message is triggered.

3.3 Printout

With the printout function, you can document a plant and its production data. A printout can be output on any controller of an automation network or be triggered by the operator of a plant. It is also possible to trigger the print automatically at pre-defined times.

In the configuring phase, you define the layout of the printouts by means of a user-friendly print-out editor. The printout consists of printout frame and printout body. The printout frame contains the header and the footer. The header and footer lines may contain, in addition to fixed terms, page number, date and time. The body is a combination of texts, process variables and messages from the message buffers. The process variables can be configured in variable fields (V-fields). The printouts may consist of several pages.

In the higher performance field, the texts are provided with attributes, such as:

- Character set (German, international, French, etc.)
- Type font (*italics*, **bold**, underlined, s p a c e d)

The configured printouts are managed by GRACIS in the printout lists.

You may assign different priorities to the printouts. A printout of higher priority will be printed before one of lower priority. A message of higher priority may interrupt the output of a printout on the printer.

○	Printout of system parameters			○
○	Group data			○
○	Number of groups: 2			○
○	Group number:	1		○
○	Group designation:	Transmission casing		○
○	Number of transfer lines:	4		○
○	Transfer line 1/1	38-AC-199-X	4 stations	○
○	Transfer line 1/2	38-AC-202-X	2 stations	○
○	Transfer line 1/3	38-AC-580-X	2 stations	○
○	Transfer line 1/4	38-AC-088-X	6 stations	○
○	Group number:	2		○
○	Group designation:	Motor casing		○
○	Number of transfer lines:	2		○

Fig. 3.4 Example of a printout

3.4 External Memory (only HPF)

GRACIS provided additional memory space for the SIMATIC S5. Via the external memory function, the SIMATIC S5 can store data (E, A, M, DB, DX) in the GRACIS external memory and read them out when needed. The external memory function stores the data on RAM disk, diskette drive or on the hard disk of the GRACIS system as a file. A file can contain up to 512 data blocks (256 PDB/RDB and 256 PDX/RDX). Thanks to the possibility to create several files, very large S5 data quantities can be stored on GRACIS. In practice, the memory size is limited by the size of the available RAM disk or hard disk.

Data exchange between the SIMATIC S5 and the GRACIS external memory is effected via standard function blocks.

The external memory function can be executed network-wide with the central function control.

3.5 Access Security Feature / Password Locking (only HPF)

Active fields and input or input/output fields can be password-protected. For this purpose, a password list must be configured for the GRACIS system. A password list contains the respective user ID's, the passwords and the password levels.

If a password protection has been defined for an operating element or input field, a password level is assigned to the operating element. The operator who wants to use this operating function has to know a password with at least the configured level.

PASSWORD INPUT	
<input type="button" value="F1 Accept"/> <input type="button" value="F2 Abort"/>	
Password	***
User	Meier
Level	14 MIN 9

Fig. 3.5 Password input

3.6 GRACIS Network Management (GNM)

The new GRACIS Network Management Software is an easy-to-handle network configuring tool for GRACIS. By means of a clear, menu-driven environment (SAA standard) with extensive, context-sensitive help functions, you can configure the local databases under MS-DOS and FlexOS. Uploading and downloading is effected under FlexOS via CP1413 and CP1412.

3.7 Central Function Control ZFS (only HPF)

The ZFS makes the SIMATIC S5 an active partner in the network between SIMATIC S5 and GRACIS. This is due to function blocks, which can execute the following functions:

- Write/read/delete data blocks on the external memory
- Save/read/delete data blocks on diskette
- Send key code
- Set variable fields in process displays
- Inquire the cursor position
- Select active fields/displays/windows
- Set/reset messages
- Trigger printouts
- Read/set the time (locally)
- Operate the data maintenance system (locally)
- Send data to the GRACIS user interface

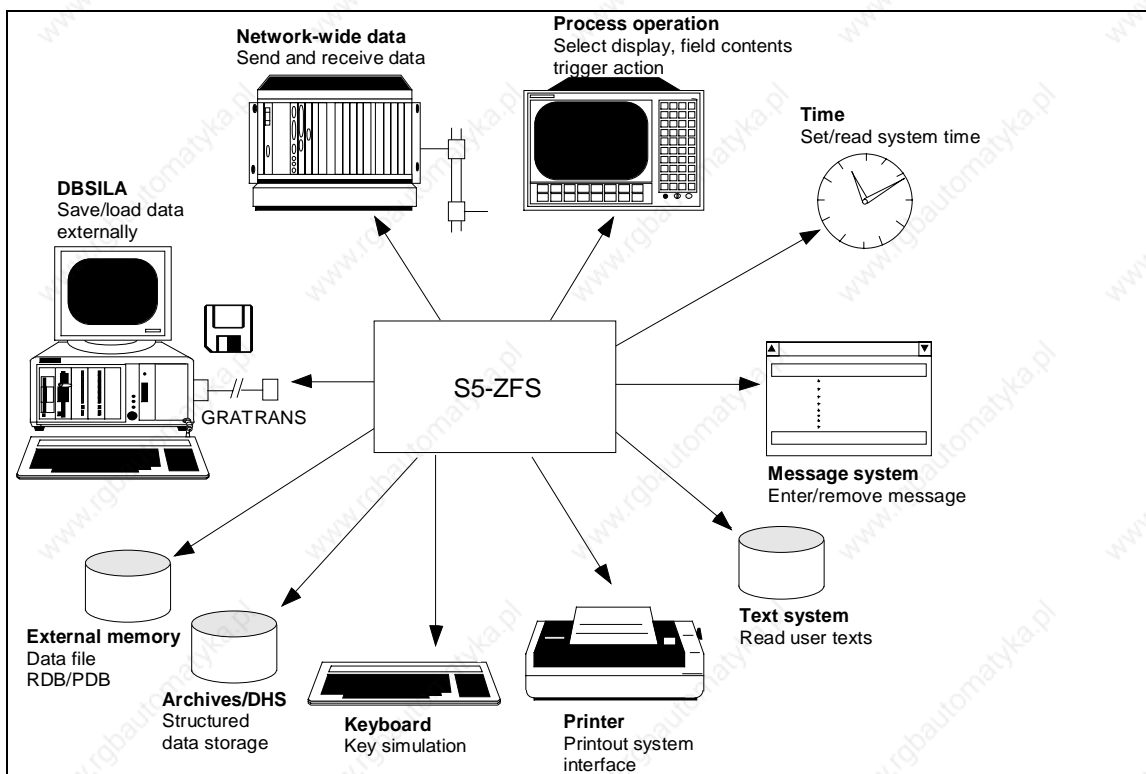

Fig. 3.6 Central function control

With the central function control (ZFS), a procedure which is the opposite of polling can be implemented. With the ZFS, data are no longer called by the GRACIS system, but upon the initiative of the SIMATIC S5 itself. For this purpose, the ZFS package includes function blocks, which are loaded into the SIMATIC S5. In case of data modifications, the FB's are conditionally called and transfer the modified data to GRACIS. The advantage of the ZFS lies in the optimization of the data exchange, as communication is only effected if data are modified. Therefore, the ZFS is useful above all for monitoring a large number of data which rarely change, e.g. a message system.

In a process display or message system, both polling and the ZFS procedure can be used in combination.

3.8 Service Module

The service module observes and controls variables (PG function) network-wide. The service module can be selected from any process display via an active field. You may parameterize any data source of the automation network, network-wide, have its values displayed and edit them.

With the service module, you can implement the following functions:

- Selection of the programmable logic controller in the network (node number=K0...255) (HPF)
- Selection of the CPU
- Free selection of the representation format of each value (similar to the PG function STEUERN-VAR)
- Format extension
- Representation of a value block with start and sequence values
- Alphanumeric parameter input
- Selection of DX-blocks
- Selection of data word number > 255

The parameter screen forms can be saved and loaded (HPF) in display blocks (BB0...BB255). The display block BB0 has a special function. If a BB0 exists when the program of the service module is started, the parameter set stored there is automatically revealed upon opening of the display. In addition, S-flags can be diagnosed.

The screenshot displays the 'GRACIS Service module' interface. It is divided into several sections:

- Header:** 'GRACIS Service module' with a trademark symbol.
- Parameters:** A list of parameter names in input fields, including MW123 KH1, RDB1 DW 100 KH1 F1, PDB1 DW 100 KH1 F1, DB1 DW 100 KH1, K1 CPU1, DB1 DL 100 KH1, MW8 KH2, K2 CPU1, EW8 KM1, and DB10 DW 120 KH1.
- Output values:** A list of corresponding values, including 0000, 14A1, A100, 0000, 0000, 0000 1010, 0001101100111110, and 0000. A double asterisk (**) is placed between the second and third rows.
- Run #:** A greyed-out field on the right side.
- Data read from MASTER:\SERVICE\BB001.TM:** A greyed-out message line.
- Function keys:** A row of eight keys labeled F1 through F8 with descriptions: F1 Param., F2 Edit, F3 Load, F4 Save, F5, F6 Start, F7 Abort, and F8 Return.
- Labels at the bottom:** 'Parameter fields' points to the parameter input fields, 'Marking fields' points to the asterisks, 'Function key assignment' points to the F1-F8 keys, 'Display fields' points to the output value fields, 'Message line' points to the data read message, and 'Status field' points to the Run # field.

Fig. 3.7 Service module

3.9 Pixel Graphics (only HPF)

PCX files (created with CAD programs or scanner software) can be converted into the GRACIS display element "pixel element". Pixel graphics can contain up to 16 colours.

3.10 System Texts in Russian

This option comprises the texts of the operating environment with Cyrillic character set during configuring (including message system and printout).

3.11 Process Simulation

The systems of the higher performance field offer the advantage of quick switchover between configuring and process operation. With LPF systems, you cannot configure on the target system. GRACIS configuring offers, however, a process mode in which all process data are mapped on a DB area. Display continuations, revealing/hiding of elements/windows, etc., can be tested, so that most target system-specific errors can be discovered and eliminated in advance. The acceptance properly speaking is, however, only possible on the target system.

3.12 User Interface GRAPI (only HPF)

The GRACIS user interface enables the utilization of GRACIS functions via user programs in the programming language C. With this, even complex functions and tasks can be realized, e.g. tool management, MDE/BDE, etc., without taking processing time of the SIMATIC S5.

The GRACIS user interface permits access to data and data blocks, process displays, the data maintenance system, printers, system time, message and printout system.

3.13 WFGRAKO

Users having worked with the WF 470 before can convert WF 470 displays into GRACIS displays with the help of the WFGRAKO conversion program.

The conversion comprises:

- V-fields
- Static text fields
- Static message windows
- Text lists including standard texts and sequence lists

Any necessary adaptations regarding character set etc., as well as the remaining elements, e.g. graphic elements or active fields for the display sequence control, can then be configured with GRACIS quickly and easily.

3.14 Diagnosis Journal (only HPF)

The diagnosis journal for GRACIS PG/OP allows local and network-wide filing, documentation and diagnosis of:

- Sequence chain faults (with GRAPH 5/II standard package)
- Linkage faults (with the message system option) and
- Network faults

Due to the openness of the GRACIS software and the fixed definition of the interfaces of the software packages S5-DOS/MT and GRACIS, you can configure, for example, that the GRAPH5/II-standard package under S5-DOS/MT is automatically started in addition to the GRACIS software when a sequence chain fault occurs. The user may also be prompted into the faulty sequence or transition magnifier. Commissioning and monitoring of a plant are thus considerably facilitated.

Furthermore, the following data are registered in the archives:

- Missing condition as operand, symbolic short and long comment (automatic display from assignment list of the S5-DOS/MT package)
- Date, message length, time of *Incoming message* or *Outgoing message*

The following functions can be implemented with the GRACIS diagnosis journal:

Function	GRAPH5/II	Message system	Network
Filing	X	X	X
Automatic acknowledgement	X	X	X
Acknowledgement by GRACIS	X		
Extended information window	X	X	X
Printout	X	X	X
Delete entries	X	X	X
Memo archives	X	X	X

In the extended information window, the remaining data of a fault are displayed if there is not sufficient space in the message line. In the memo archives, the user can file comments on a fault occurred which he can call when the fault occurs again. Efficient diagnosis tools, linked via process communication, are available for analysis and elimination of the fault.

Function	GRAPH5/II	Message system	Network
Sequence chain overview*	X		
Graphic representation of the chain*	X		
Action*	X		
Transition*	X		
Operation of the sequence chain*	X		
Service module	X		
Network diagnosis			X

* in connection with GRAPH5/II-MT

3.16 Modification journal (only HPF)

The modification journal permits monitoring and filing of the values input in variable fields defined by the user for critical process parameters.

MODIFICATION JOURNAL			
F1 Accept		F2 Abort	
Password	**	User	MG
Journal	Brewer's copper 1	No	190
Date	01.06.93	Time	10:10:10
Field name	Temperature		
Old value	100	New value	90
1	too high	9	
2	too low	10	
3		11	
4		12	
5		13	
6		14	
7		15	
8		16	

Fig. 3.9 Modification journal

In the modification journal, the following values are filed, printed, and can be watched or edited with password protection:

- Journal name and number
- V-field name
- Date and time of the modification
- Old and new value
- Up to 16 reasons of modification
- Operator's name

With these archives, subsequent interventions into the process can be traced.

3.17 GRACIS NC-Data Management

In a system networked via SINEC L2-TF, the NC-data management stores NC-programs from different SINUMERIK 805 SM-TW centrally on the hard disk, structured in paths. If necessary, the central data maintenance guarantees a quick re-transfer of the programs to the individual controllers.

3.18 Standard B-GRACIS

With the Standard B-GRACIS operator environment, operation and diagnosis as well as data supply and management of the technology modules WF 721, WF 723 A and WF 723 B can be implemented. Separate menu branches are available for management, supply, configuration and configuring. The Standard B-GRACIS also runs under SINEC H1 and SINEC L2. In addition to standard screen forms, freely configurable screen forms are offered.

Standard screen forms

- Machine data input
- Actual-value display
- MDI and set-up
- Parameter input
- Tool offset input
- Commissioning
- Diagnosis
- Central data management and data supply

Unit: WF723B Axis: <input type="checkbox"/> X <input type="checkbox"/> Y <input type="checkbox"/> Z	Program input								
Operating	Order running								
	FAULT								
Prog. No. : 1 Block No. : 8									
<pre> N1 G90 G01 X400.000 Y200.000 F5000.00 N2 G01 X500.000 Y300.000 M1=10 N4 R1=10.000 R2=2000.00 N5 G90 X=R1 F=R2 N6 G90 G43 X20.000 F4000.00 D5 N7 M1=30 </pre>									
<pre> N8 G90 F2.00 X100.000 M1=18 </pre>									
<table border="1"> <tr> <td>F1</td> <td>F2 Accept</td> <td>F3 Delete</td> <td>F4 Page +</td> <td>F5 Page -</td> <td>F6 Prog.Info</td> <td>F7 Dianosis</td> <td>F8 Return</td> </tr> </table>		F1	F2 Accept	F3 Delete	F4 Page +	F5 Page -	F6 Prog.Info	F7 Dianosis	F8 Return
F1	F2 Accept	F3 Delete	F4 Page +	F5 Page -	F6 Prog.Info	F7 Dianosis	F8 Return		

Fig. 3.10 Standard B for WF 721/723: program input

3.19 Tool and Recipe Management

With the GRACIS tool and recipe management (WRV) you can manage files structured in paths.

Through input in process displays, the user determines the contents of the files (e.g. master, program, tool, machine data). Shape, colour and text arrangement of the process displays for input and management are freely configurable.

The data can be transferred to PLC's and can also be read on PLC's.

The WRV stores and manages the files centrally on the master station. The operation of the file management as well as the data transfer can be effected network-wide on all devices involved in the WRV network.

The WRV is divided into four functional parts:

- Configuration
- File management
- Part management
- Tool/recipe input

The user can freely configure the contents of the files via GRACIS display.

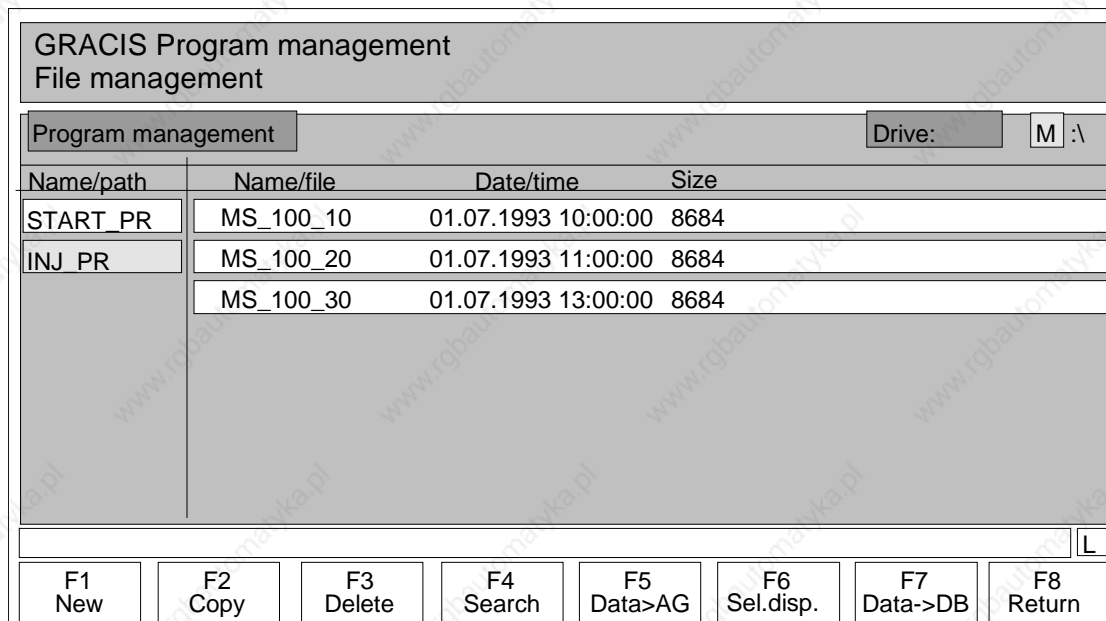

Fig. 3.11 Example of tool and recipe management

3.20 Form and Scope of Delivery

Software	GRACIS software packages	HPF	LPF
Basis	Configuring Displays Message system Printouts System texts	<input type="radio"/> <input type="radio"/> <input type="radio"/> <input type="radio"/>	<input type="radio"/> <input type="radio"/> <input type="radio"/> <input type="radio"/>
	Process operation Displays Message system Printouts External memory function Service module GRAPH5 screen forms	<input checked="" type="checkbox"/> <input checked="" type="checkbox"/> <input checked="" type="checkbox"/> <input checked="" type="checkbox"/> <input checked="" type="checkbox"/> <input checked="" type="checkbox"/> <input checked="" type="checkbox"/>	<input checked="" type="checkbox"/> <input checked="" type="checkbox"/> <input checked="" type="checkbox"/> <input type="checkbox"/> <input checked="" type="checkbox"/> <input checked="" type="checkbox"/> <input checked="" type="checkbox"/>
Options	Pixel graphics	<input type="radio"/>	-
	GRAPI interface	<input type="radio"/>	-
	Central function control ZFS	<input type="radio"/>	-
	GRACIS Network Management GNM	<input type="radio"/>	-
	System texts in Russian	<input type="radio"/>	in prep
	Modification journal	<input checked="" type="checkbox"/>	-
	GRAPH5/II diagnosis	<input checked="" type="checkbox"/>	<input checked="" type="checkbox"/>
	Tool and recipe management	<input checked="" type="checkbox"/>	-
	Diagnosis journal	<input checked="" type="checkbox"/>	-
	NC-data management	<input checked="" type="checkbox"/>	-
	Standard B-GRACIS for WF 721/723A	<input checked="" type="checkbox"/>	in prep
	WFGRAKO	<input type="radio"/>	<input type="radio"/>

Configuring

Process operation

Media

The configuring is supplied on diskette.

The process operation is supplied on the target device (for CP470 and OP30SM on firmware, for CP48x and OP40SM on hard disk). For PG/PC, the process operation is available on diskette.

The options are available on diskette.

4 Communication

4.1 GRACIS-S5 - SIMATIC S5

The dual-port RAM is the communication interface between GRACIS and the central unit of a programmable logic controller. The dual-port RAM is located on the GRACIS-CPU. It is a memory area in which either side can leave and call information. Communication takes place via standard handling blocks.

The data supply of the GRACIS standard functions, such as e.g. display, printout and message system, is initiated by GRACIS, i.e. GRACIS sends at freely configurable intervals data requests to the respective SIMATIC S5-CPU's. In the SIMATIC S5, the data requests are processed by the standard handling blocks and the desired data are transferred to GRACIS (polling). The advantage of this procedure is the fact that no S5 user program is needed for animation of the displays and for the data of printouts and messages, so that the SIMATIC S5 is available for control functions (memory space, cycle time).

With the ZFS option, you may also implement a procedure in which data supply is initiated by the SIMATIC S5 instead of GRACIS (see also under "ZFS").

4.2 Communication GRACIS-OP - SIMATIC S5

The OP30SM is serially connected to the PG interface of the PLC. For data transfer, the AS511 printout is at present available. An interface module for SINEC L2 is in preparation.

The OP40SM can serially be connected to the PLC or to SINEC L2/SINEC H1. For serial connection, the OP40SM is connected to the PG interface of the PLC via the integrated standard interface (COM1/COM2;TTY/V.24). For network connection, the CP1413 or CP5410 are at choice available for SINEC H1 or SINEC L2, respectively.

4.3 Communication GRACIS SINEC H1/L2

The communication software is part of the GRACIS SINEC H1 interface. The network connection is configured with the help of the NML or GNM software package.

The participants of the network are defined upon configuring a GRACIS network. The data for the network configuration are stored in GRACIS.

During process operation, process data can be requested e.g. from all network nodes.

In a GRACIS network, you may also use systems without GRACIS components.

Via the communication processor CP143 for SINEC H1, or CP5430 for SINEC L2, SIMATIC S5 programmable logic controllers without a visualization of their own can be connected to the GRACIS visualization system.

Via a CP231A, a SINUMERIK 880 can be a partner in the GRACIS network.

5 Configurations

Configuring phase

Typically, configuring is done in off-line operation on the PG; i.e. during this phase, the target device need not yet be connected to the PG. With GRACIS HPF, you can also configure on the target device.

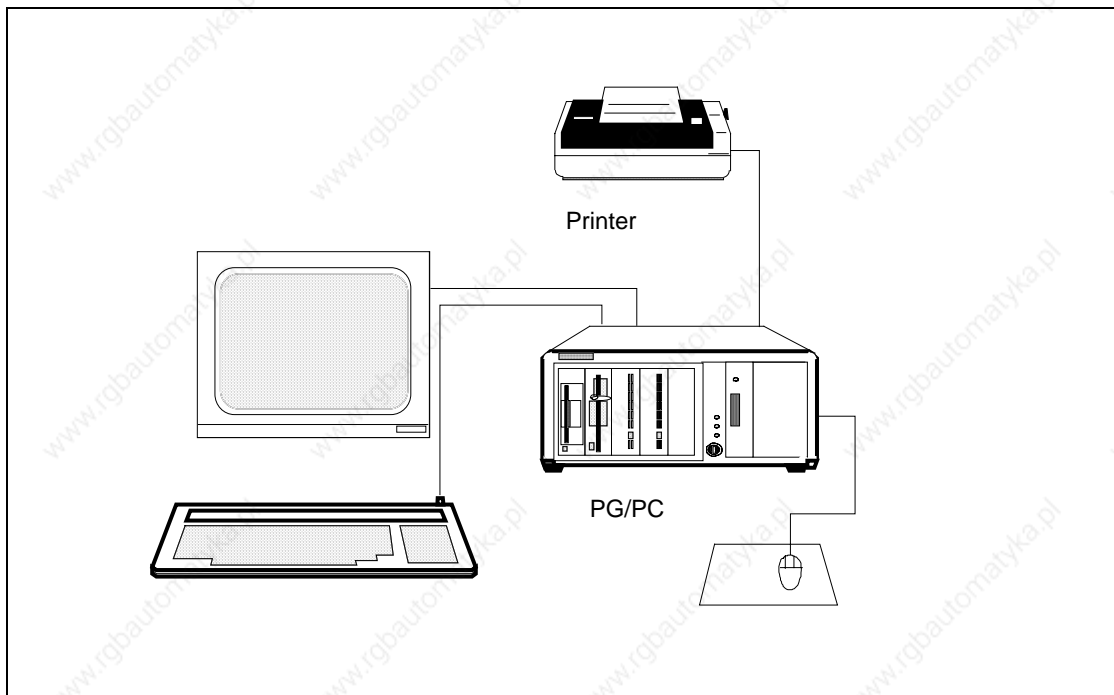

Fig. 5.1 Configuring phase

During the configuring phase, the configuring data are stored on a diskette or on the hard disk of the PG and are transferred for the program test into the user memory of the target device. The configured data are transferred via serial coupling or - with GRACIS HPF - also via diskette.

A test of limited extent is possible in configuring through the process simulation mode. All process data are mapped on a DB-area, and the display continuations, the revealing/hiding of elements/windows, etc. can be tested.

Process operation phase

For the CP4xx, the serial interface is at present occupied by the process operating keyboard or the integrated keyboard of the monitor panel.

For the OPxxSM, the serial connection is made to the PLC interface.

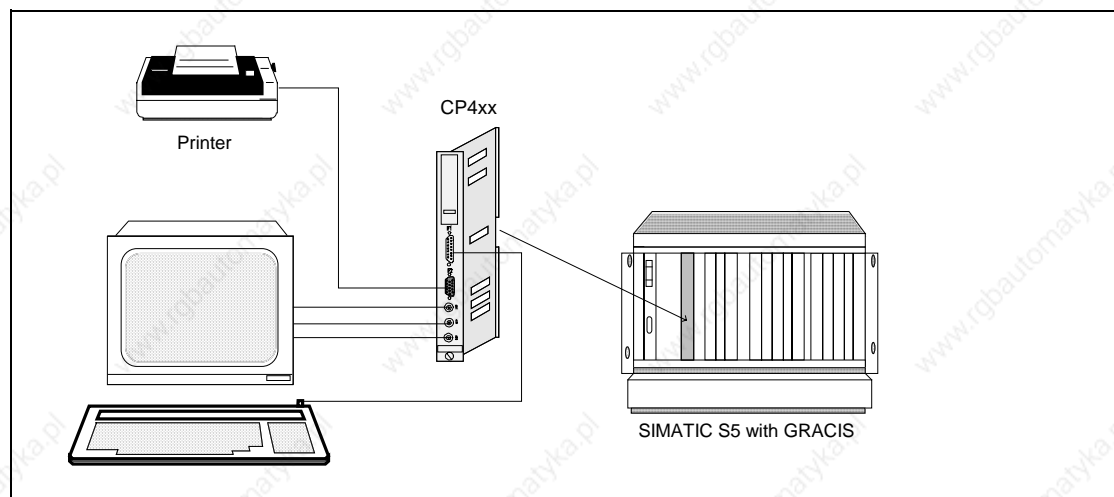

Fig. 5.2 Process operation phase GRACIS-CP

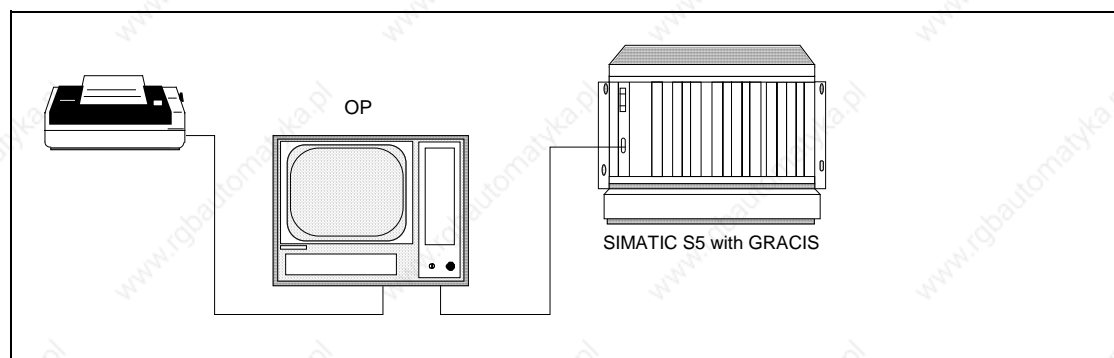

Fig. 5.3 Process operation phase GRACIS-OP

By means of the integrated function and system keys, you can monitor and control the process, prompted by menus. You can enter nominal values and control actuators (e.g. valves) of the process. The statuses of the inputs, flags, etc., necessary for display dynamization, are requested by the target device either via the backplane bus or via the communication interface of the SIMATIC S5.

6 Technical Data

	OP30SM	OP40SM	CP470	CP485/6
Processor	V25/12MHz	80386SX/25MHz 80486SX/25MHz 80486DX/33MHz	80C186/16MHz	80386SL/25MHz
Operating system	RMOS	FlexOS	RMOS	FlexOS
Dual-port RAM	-	-	8.5 kB	16 kB
Main memory	-	10/16 MB RAM	-	8 MB RAM
User memory	256 KB flash EPROM + option (256, 512 or 768 KB)	approx. 80 MB hard disk	Memory cards: 512 kB, 1 MB or 2 MB RAM	approx. 115 MB hard disk
Colours	EL: 8 grey levels LCD: 8 colours	16 colours	8 colours	16 colours
Location	Stand-alone	Stand-alone	1 slot (1 1/3 SEP)	CP485: 2 slots (2 x 1/3 SEP) CP486: 3 slots (3 x 1 1/3 SEP)
Supply voltage	24 V DC \pm 25%	24 V DC \pm 25%	int.: +5 V \pm 5% ext.: +24 V +25%,-15%	int.: +5 V \pm 5% ext.: +24 V +25%,-15%
Power consumption	EL: 30 W LCD: 50 W	100 W	at 5 V: 1.8 A at 24 V: 80 mA	CP485: at 5V: 2.5 A (max. 3.0 A), at 24 V: 0.1 A CP486: +1.8 A for CP1413 +1.2 A for CP5410
Weight	EL: 4.2 kg LCD: 5.1 kg	7 kg	approx. 0.55 kg	CP485: approx. 1.5 kg CP486: approx. 1.9 kg
Ambient temperature - in operation - during transport and storage	0° to 40°C EL: -20° to +70°C LCD: -20°C to +60°C	0° to 40°C -20° to +70°C	0° to 55°C -40° to +70°C	+5° to +40°C +5° to +50°C
Humidity in operation	Class F, no condensation	Class F, no condensation	Class F, no condensation	8-80% at 25°C, no condensation
Interfaces	SS1: TTY/V.24 for PG, PLC, printer SS2: TTY/V.24 for PLC	COM1 TTY/V.24 COM2: V.24 LPT1: TTL for parallel printer process operating keyboard MF2 keyboard 3 free 16-bit slots external floppy drive	IF1: TTY for PG, operator panel, keyboard and printer IF2: TTY/V.24 for printer	COM1: TTY/V.24 for printer, PG, AS511 COM4: cf. COM1 IF1: V.24/X.27 for process keyboard LPT: TTL for parallel printer RGB for monitor Bus connection: SINEC L2 or SINEC H1 (only CP486)

OP data	OP30SM EL	OP30SM LCD	OP40SM
Type of display	Electroluminescence	LCD TFT	
Viewing angle - horizontal - vertical	+/-80° +/-80°	+/-45° +10°/-30°	
Dimensions of front panel (anthracite) Panel cutout	414 x 324 mm 388 x 297 mm	444 x 348 419 x 323 mm	
Mounting depth/ with direct keys	98/120 mm	-/120 mm	125/ - mm
Touch-sensitive keyboard	x		
Function keys with LED	16		
Operating keys/with LED	40/16		
Direct keys	2 modules per 4 keys		-
Key-operated switch	x		
Interference voltage/ perturbing radiation - acc. to VDE 0871 - acc. to VDE 0875	Curve A for f < 10 kHz Part 3 for f < 10 kHz		Curve B -
Electrical safety	VDE 160		
Protection class	IP65 on the front panel		

Siemens AG
AUT V240
Postfach 3180

D-91050 Erlangen

From:

Name: _____

Company/Dept.: _____

Address: _____

Telephone: _____ / _____

Suggestions

Corrections

For Publication / Manual:

GRACIS
Description

Order No.: 6ZB5 440-0TY02-0BA0
Edition: March 1994

Should you come across any printing errors when reading this publication, please notify us on this sheet. Suggestions for improvement are also welcome.

Suggestions and / or corrections:

Content and target group of the GRACIS documentation

Acquisition phase

Product Brief HPF/LPF

6ZB5 440-0TX02-0BA1

Target group: O/I users

General, brief overview of the GRACIS system covering hardware and software components.

Description HPF/LPF

6ZB5 440-0TY02-0BA0

Target group: O/I users

General system overview

AR10 Catalog HPF/LPF

E86060-K6310-A101-A4-7600

Target group: Special machine builders

Order numbers / scope of supply

General GRACIS publications

Operator Interface HPF/LPF

6ZB5 440-0UD02-0AA0

Target group: GRACIS configurat. engineer

Like all system, GRACIS has its own term.

Terms like "work window", "slider", etc. are explained for you. You will also get to know the GRACIS operator panels. The last chapter lists the operator panels against their functs.

GRACIS LPF

Technical Description LPF

6ZB5 440-0VD02-0AA1

Target group: Startup engineers/
system configuration engineers/
process operators

This publication enables you to start up a GRACIS system.

The emphasis is on hardware startup. There is a description of how to incorporate the components from the configurat. stage (S5 program list and GRACIS list) .

You will become familiar with the GRACIS-specific characteristics in process mode..

- Service modul
- GRAPH 5 sequence diagnostics

Configuration LPF

6ZB5 440-0VE02-0AA0

Target group: GRACIS configurat. engineer

With its information on how to configure GRACIS, you are certain to use this publication frequently in the future.

- First steps in configuring
- Management, system services

Configuring from

- Process displays
- Printouts
- Text list
- Messages
- GRAPH 5

Configuration stage GRACIS HPF

SIMATIC S5 Interface (local and SINEC H1)

6ZB5 440-0UB02-0AA0

Target group: S5 programmers

You get to know the interface between SIMATIC S5 and GRACIS for local and SINEC H1 networked systems.

You program the exchange of process displays and the specialist applications of central function control.

SIMATIC S5 Interface (SINEC L2)

6ZB5 440-0UW02-0AA1

Target group: S5 programmers

You get to know the interface between SIMATIC S5 and GRACIS for local and SINEC H1 networked systems.

You program the exchange of process displays.

Configuration HPF

6ZB5 440-0UE02-0AA1

**Target group: GRACIS configurat.
engineers**

With its information on how to configure GRACIS, you are certain to use this publication frequently in the future.

- First steps in configuring
- Management, system services

Configuring of

- Process displays
- Printouts
- Text list
- Messages
- Access control
- GRAPI
- GRAPH 5

Networking

6ZB5 440-0UF02-0AA0

**Target group: Networking
engineers**

This publication shows you how to configure and execute a GRACIS network. It explains both serial connection and networking via SINEC L2 and SINEC H1.

Configuring Options

6ZB5 440-0UG02-0AA1

**Target group: GRACIS configurat.
engineer**

You become familiar with the available GRACIS options.

The publication gives information on functions, configuration and incorporation into the GRACIS system.

Process mode phase GRACIS HPF

Process mode

6ZB5 440-0UC02-0AA1

Target group: Process operators

Here you learn the GRACIS-specific characteristics in process mode.

You learn the effects of active fields, input/output fields, display control, cursor control and password interlocking in process mode.

- Saving GRACIS data
- Service modul
- GRAPH 5 sequence diagnostics

Technical Description HPF

6ZB5 440-0UA02-0AA0

**Target group: Startup engineers/
system configurat. engineers**

This publication enables you to start up a GRACIS system.

The emphasis is on hardware startup. There is a description of how to incorporate the components from the configuration stage (S5 program list and GRACIS lists).

