



Hardware and Engineering

PS 4-101-DD1

PS 4-111-DR1

PS 4-111-DR5

01/98 AWB 27-1157-GB

4th published 1998, 5th edition 03/98

© Moeller GmbH, Bonn

Authors: Peter Roersch

Editor: Thomas Kracht

Translator: Terence Osborn

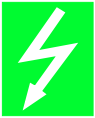

Caution!

Dangerous electrical voltage!

Before commencing the installation

- Disconnect the power supply of the device.
- Ensure that the device cannot be accidentally restarted.
- Verify isolation from the supply.
- Earth and short circuit.
- Cover or enclose neighbouring units that are live.
- Follow the engineering instructions (AWA) of the device concerned.
- Only suitably qualified personnel may work on this device/system.
- Before installation and before touching the device ensure that you are free of electrostatic charge.
- Connecting cables and signal lines should be installed so that inductive or capacitive interference do not impair the automation functions.
- Install automation devices and related operating elements in such a way that they are well protected against unintentional operation.
- Suitable safety hardware and software measures should be implemented for the I/O interface so that a line or wire breakage on the signal side does not result in undefined states in the automation devices.
- Ensure a reliable electrical isolation of the low voltage for the 24 volt supply. Only use power supply units complying with IEC 60 364-4-41 or HD 384.4.41 S2.
- Deviations of the mains voltage from the rated value must not exceed the tolerance limits given in the specifications, otherwise this may cause malfunction and dangerous operation.
- Emergency stop devices complying with IEC/EN 60 204-1 must be effective in all operating modes of the automation devices. Unlatching the emergency-stop devices must not cause uncontrolled operation or restart.
- Devices that are designed for mounting in housings or control cabinets must only be operated and controlled after they have been installed with the housing closed. Desktop or portable units must only be operated and controlled in enclosed housings.
- Measures should be taken to ensure the proper restart of programs interrupted after a voltage dip or failure. This should not cause dangerous operating states even for a short time. If necessary, emergency-stop devices should be implemented.

IBM is a registered trademark of International Business Machines Corporation.

All other brand and product names are trademarks or registered trademarks of the owner concerned.

All rights reserved, including those of the translation.

No part of this manual may be reproduced in any form (printed, photocopy, microfilm or any other process) or processed, duplicated or distributed by means of electronic systems without written permission of Moeller GmbH, Bonn.

Subject to alterations without notice.

List of revisions to AWB 27-1157-GB

Edition	Page	Revision	New	Rev.	n. a.
10/93		PS 4-111-DR1	×		
03/94	42	Slave-Mode	×		
07/95		PS 4-111-DR5	×		
01/98	15	Engineering		×	

Contents

Foreword	3
1 Hardware	5
System overview	5
Mounting	10
Installation	12
RS 485 interfaces	13
2 Engineering	15
Electromagnetic compatibility (EMC)	15
Connection overview	15
Connections	17
Control cabinet arrangement	18
Device arrangement	19
Power supply of the PS 4-101-DD1 and the inputs/outputs	20
Power supply of the PS 4-111-DR1/DR5 and the inputs/outputs	26
Device earth	30
Connecting the programming devices	32
Connection to the Suconet K1 fieldbus	34
Interference measures	34
Networking	39
Slave mode	48
3 Operation of the PS 4-100	59
Hardware	59
Software	63
Description of the functions	66
Configuration/Retentive function	73
4 Description of Errors/Diagnostics	77
Diagnostics displays	77

Contents

Appendix	79
Accessories	79
Dimensions	80
Technical Data	81
Index	87

Foreword

The PS 4-100 has been developed on the basis of the experience gained from 200.000 Moeller compact PLCs worldwide. The PS 4 represents a new concept by which specialized modules with different hardware and software features now take the place of multi-functional devices. This modular system of compact devices allows manufacturers to implement dedicated programmable controllers at a reasonable price.

The PS 4 system consists of the following three basic elements:

- PS 4 compact PLC

- EM 4 external modules

- LE 4 local expansion modules

The PS 4-100 combines all the basic devices required in the program. The compact devices provide all functions necessary for any automation task: eight digital inputs, six digital outputs, a high-speed counter (for positioning tasks etc.), integrated setpoint potentiometers for time and counter reference values. The EEPROM of the PS 4-100 has a memory capacity for user programs of up to 1000 instructions. A backup battery is not necessary. A typical application for the PS 4-100 is the control of small presses.

The PS 4-100 can be programmed in two ways. With the PRG 3 hand-held programmer or with the personal computer. The hand-held programmer with the IL editor facilitates particularly the test and commissioning functions on site. The user-friendly Sucosoft S 30-S3 programming software provides the IL, LD, FBD editors as well as supporting tasks

such as testing, commissioning and program documentation.

The PS 4-100 has two Suconet K1 fieldbus interfaces (RS 485) for connecting programming devices or external modules for remote input/output expansion. The data can be transferred via a two-wire cable up to 600 m long without the use of repeaters. In the Suconet K1 network the PS 4-100 is always the master that can address up to 230 inputs/outputs via EM 4 remote expansion modules and LE 4 local expansion modules.

EM 4 modules for expanding the system are particularly useful for controlling machines with different sensors and actuators otherwise requiring long cable runs. EM 4 modules are available for both digital and analog signals. Typical application examples include packaging systems and sewage plants. Not only the PS 4-100 can be fitted with EM 4 modules but also any programmable controller which has a Suconet K1 interface, such as the PS 316/PS 416 modular PLC systems, PS 3, PS 306 compact PLCs in addition to the PS 4.

Apart from the PS 4-100, PS 4 and EM 4 units can be provided with additional inputs and outputs by connecting LE 4 local expansion modules.

1 Hardware

System overview

Figures 1 and 2 show an overview of the user and display elements of the PS 4-101-DD1, PS 4-111-DR1 and PS 4-111-DR5 compact PLCs as well as the special features of the individual device connections.

Legend of figure 1:

- ① 24 V DC power supply
- ② 3 kHz counter input
- ③ 8 digital inputs 24 V DC
- ④ Plug-in screw terminal for the inputs
- ⑤ Input status LEDs
- ⑥ Switch for master/slave setting (S2)
- ⑦ Output status LEDs
- ⑧ Plug-in screw terminal for the outputs
- ⑨ 6 digital outputs 24 V DC/0.5 A; short-circuit-proof and overload protected
- ⑩ Suconet K1 interface
- ⑪ Setpoint potentiometers
- ⑫ Suconet bus terminating resistors (S1)
- ⑬ Suconet K1 programming interface
- ⑭ PLC status LEDs

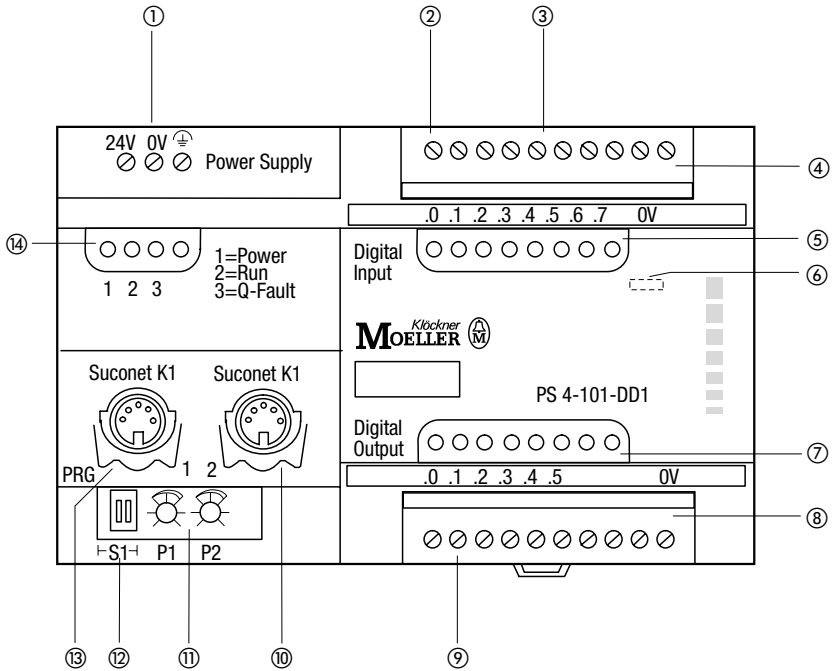

Figure 1: System overview PS 4-101-DD1

Legend of figure 2:

- ① 115 V AC ... 230 V AC power supply
- ② 3 kHz counter input
- ③ 8 digital inputs 24 V DC
- ④ 24 V DC power supply for the 8 digital inputs
- ⑤ Plug-in screw terminal for the inputs
- ⑥ Input status LEDs
- ⑦ Switch for master/slave setting (S2)
- ⑧ Output status LEDs
- ⑨ Plug-in screw terminal of the outputs
- ⑩ 6 relay outputs 24 V DC/2A; 230 V AC/2 A (resistive load)
- ⑪ Suconet K1 interface
- ⑫ Setpoint potentiometers
- ⑬ Suconet bus terminating resistors (S1)
- ⑭ Suconet K1 programming interface
- ⑮ PLC status LEDs

System overview

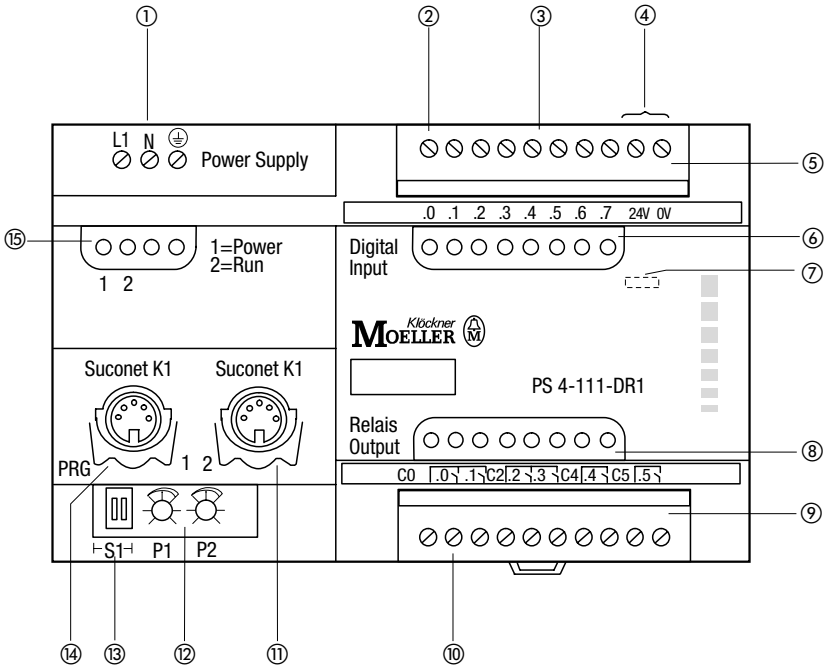

Figure 2: System overview PS 4-111-DR1/DR5

Mounting

Top-hat rail

Proceed as follows when mounting a PS 4-100 on a top-hat rail:

- ▶ Hook one side of the device against the top-hat rail ①.
- ▶ Use a screwdriver to slide the spring-loaded clip ② out of the device.
- ▶ Push the device against the top-hat rail ③.
- ▶ Remove the screwdriver. The spring-loaded clip should snap back into position and hold the device securely ④. Check that the device is attached properly.

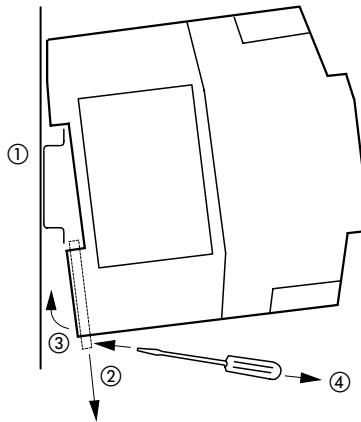

Figure 3: Mounting on top-hat rail

Fixing brackets

Proceed as follows when mounting a PS 4-100 on fixing brackets:

- ▶ Insert each of the fixing brackets so that they snap into position ①.
- ▶ Check that they are seated correctly. The lug must snap into place in the hole of fixing bracket ②.
- ▶ Fasten each fixing bracket to the mounting plate using an M4 screw ③.

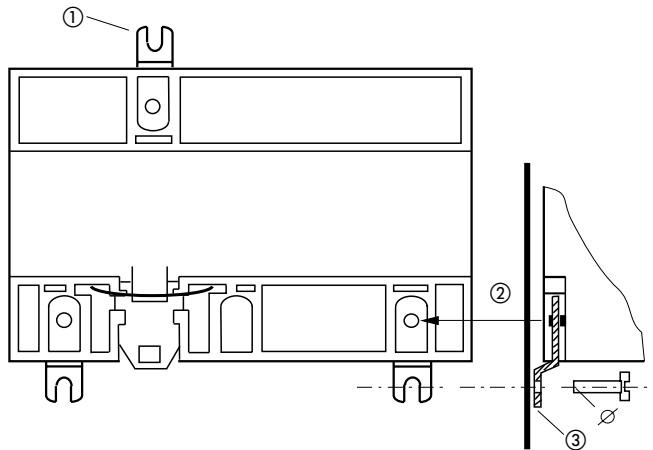

Figure 4: Mounting with fixing brackets

Installation

The device can be installed either horizontally or vertically.

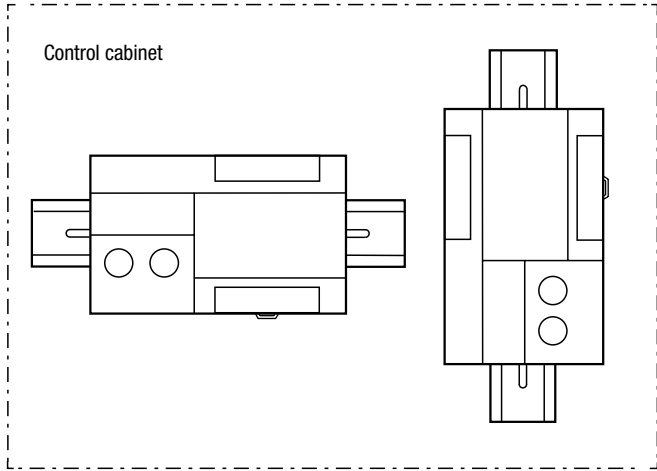

Figure 5: Installation

RS 485 interfaces

Proceed as follows when connecting the plug to the interface:

- ▶ Push the retaining clip to the side ①.
- ▶ Insert the plug ②.
- ▶ Push the retaining clip over the top of the plug ③.

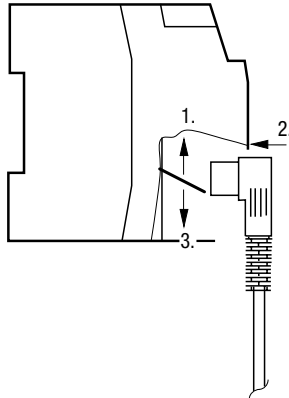

Figure 6: Connecting the plug

To remove the plug:

- ▶ Push off the retaining clip ① and
- ▶ Pull out the plug ② (with a screwdriver if necessary).

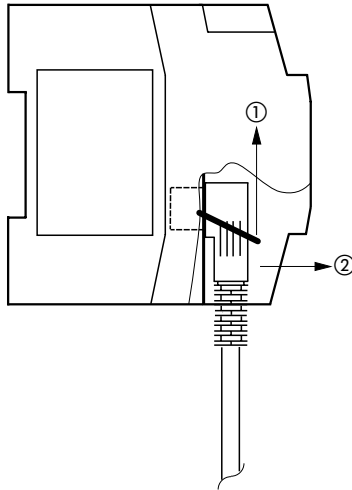

Figure 7: Removing the plug

2 Engineering

Electromagnetic compatibility (EMC)

Observe the engineering instructions in the manual EMC Engineering Guidelines for Automation Systems (AWB 27-1287).

Connection overview

Screened data and signal cables

- ▶ Route screened data and signal cables on the left and the right of the device along the shortest distance and connect the screen braid to the reference potential using low impedance connections and large contact areas.
- ▶ Connect the screen braid with the metal sleeve of the plug connector (DIN plugs). There should be no breaks in the screen braid.

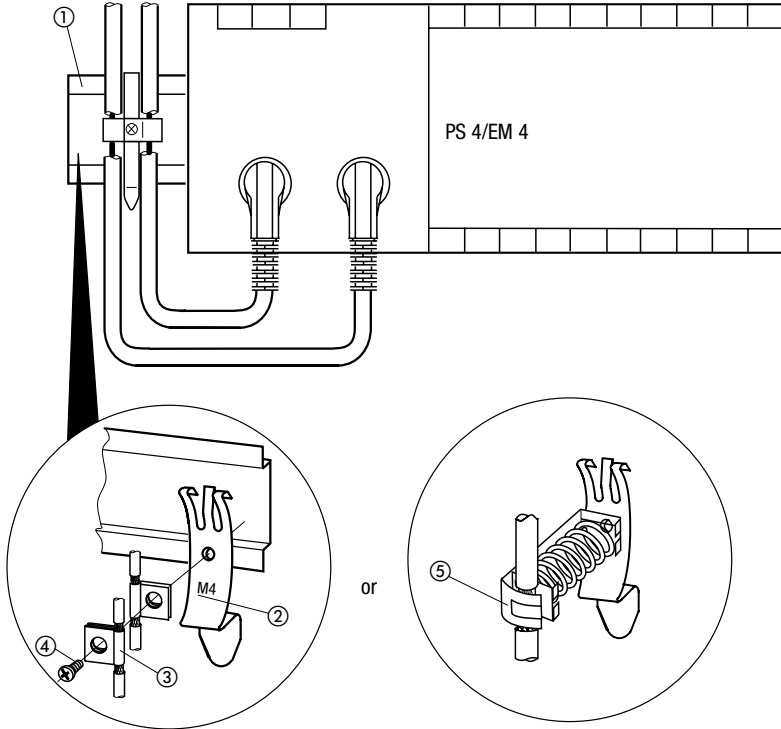

- ① Top-hat rail
 - ② Mounting clip
 - ③ Contact clip
 - ④ Screw
 - ⑤ Terminal clip
- ②, ③, ④ are supplied with the screen earth ZB 4-102-KS1

Connections

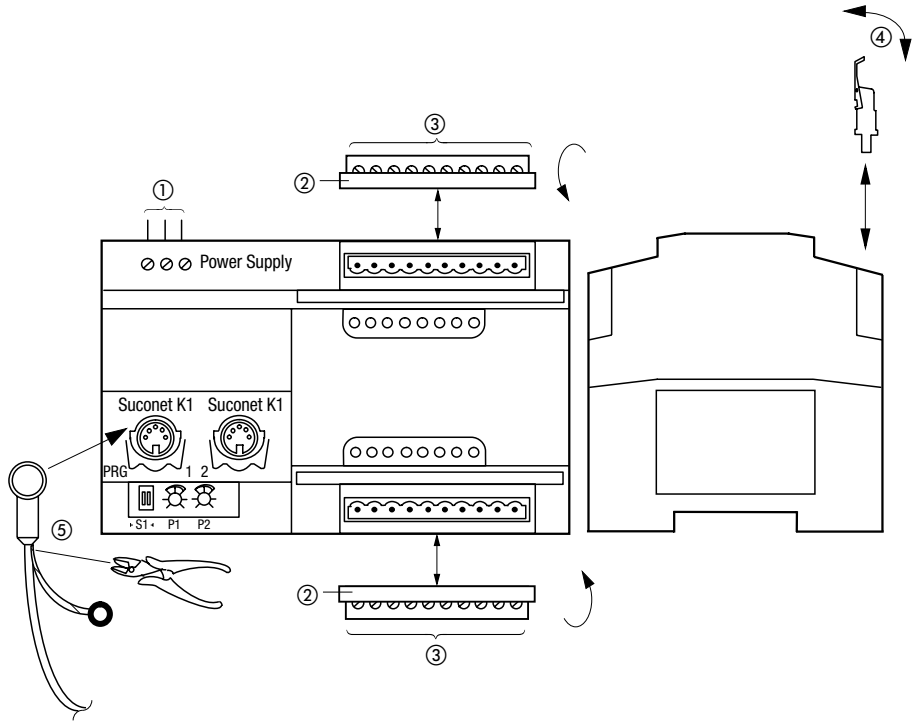

Figure 8: Connections

- ① Screw terminals
Power supply connection, terminal cross-section
flexible with ferrule 0.22 ... 2.5 mm² (AWG 18 ... AWG 13)
without ferrule 0.22 ... 2.5 mm² (AWG 18...AWG 13)
Protective earth/function earth
- ② Plug-in screw terminal
- ③ Terminal cross-sections:
All input terminals are designed for
0.22 ... 2.5 mm² (AWG 18 ... AWG 13) or
0.22 ... 2.5 mm² (AWG 18...AWG 13)
- ④ Protective cover; used to lock terminal in position when
inserted
- ⑤ Cut the screen

Control cabinet arrangement

The interference-free operation of the system or machine largely depends on the arrangement of components in the control cabinet. When planning, designing and constructing a plant or device, ensure that the power and the control sections are spatially separated from each other. The power section includes:

- Contactors
- Coupling modules
- Transformers
- Frequency inverters
- Current converters
- DC power supply units

We recommend the division of the cabinet into sections according to different power and interference levels in order to effectively eliminate electromagnetic interference.

When using small control cabinets sufficient protection should be ensured by using dividers in order to reduce the interference.

Ventilation

In order to ensure sufficient ventilation for the PS 4-100 ensure a minimum clearance of 5 cm (2") from the ventilation slots.

The values stated in "Technical Data" (see Appendix) must be observed.

Device arrangement

The PS 4-100 can be mounted horizontally or vertically.

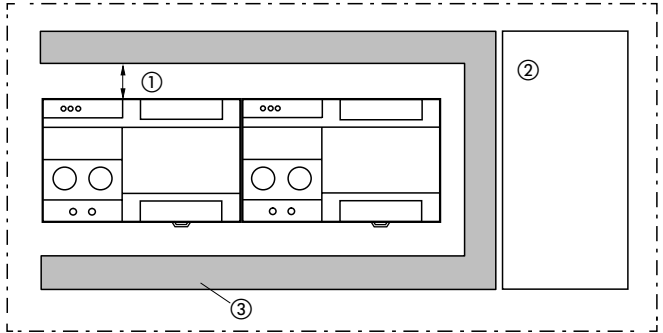

Figure 9: Horizontal arrangement

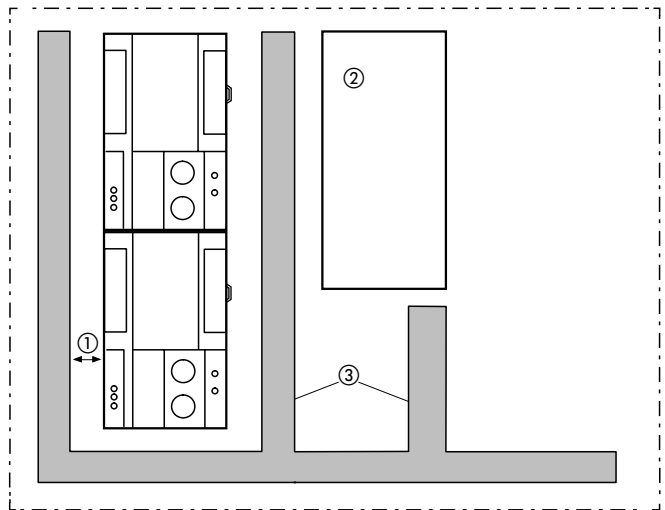

Figure 10: Vertical arrangement

- ① At least 50 mm (2")
- ② Power section
- ③ Cable duct

Power supply of the PS 4-101-DD1 and the inputs/outputs

The following pages show the following power supply options:

Common power supply of the PS 4-101-DD1 and the inputs/outputs in earthed operation. (figure 11)

Common power supply of the PS 4-101-DD1 and the inputs/outputs in unearthed operation. (figure 12)

Common power supply of the PS 4-101-DD1 and the inputs with a separate power supply for the outputs in earthed operation. (figure 13)

Legend of figure 11:

- ① Protection of the power supply unit
- ② 0 V reference point for inputs
- ③ Power supply outputs
- ④ Follow the instructions on "Device earth" on page 30.
- ⑤ Power supply of the PS 4-101-DD1
- ⑥ 24 V DC power supply for inputs
- ⑦ 24 V DC miniature circuit-breaker

Power supply of the
PS 4-101-DD1 and the
inputs/outputs

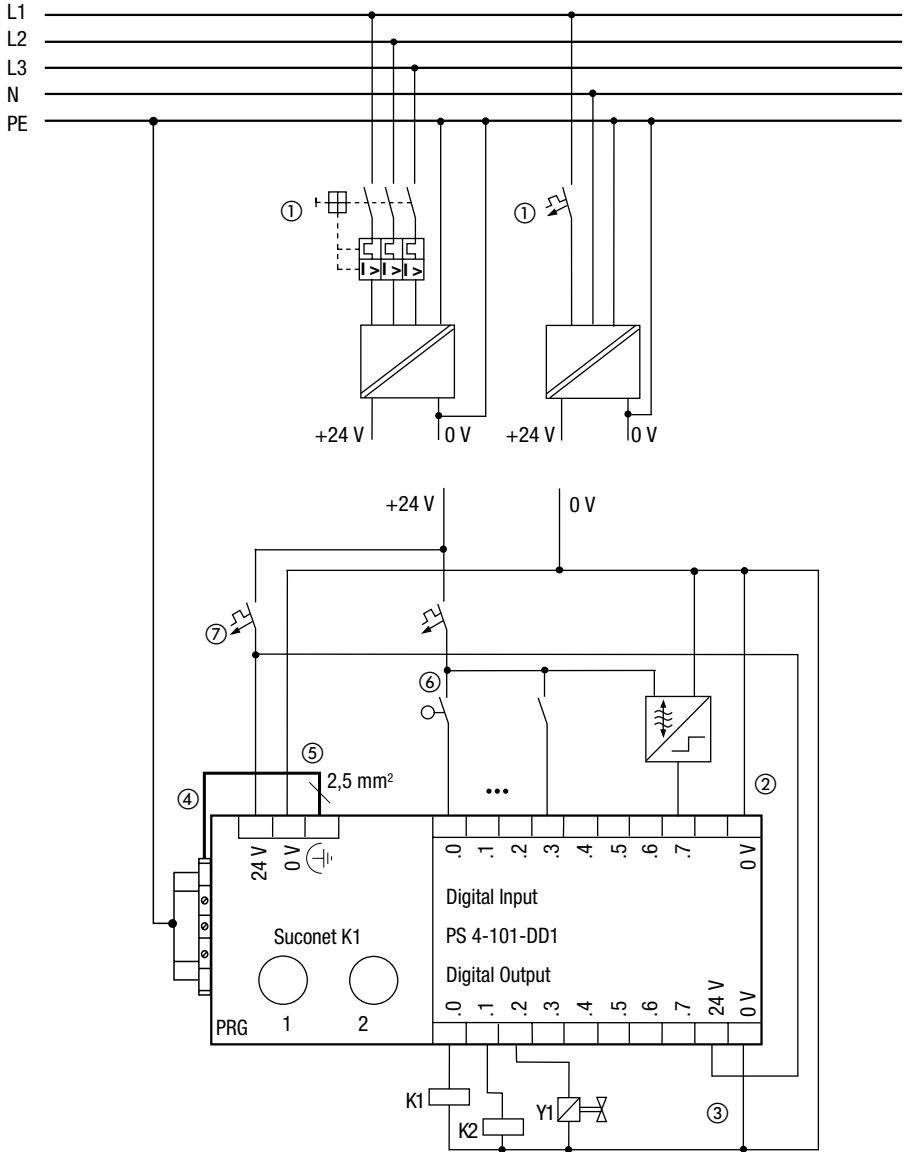

Figure 11: Common power supply, earthed operation



When using an unearthed supply voltage you must implement an insulation monitoring circuit (IEC EN 60204-1).

The 24 V DC power supply must be a safety extra-low voltage acc. to IEC 204-1 or IEC 364-4-41 for potentially isolated operation.

Legend of figure 12:

- ① Protection of the power supply unit
- ② Miniature circuit-breaker
- ③ Earth fault monitoring device (e.g. ERE/F)
- ④ 0 V reference point for inputs
- ⑤ Output power supply
- ⑥ PS 4-101-DD1 power supply
- ⑦ Follow the instructions on page 30 Earthing the devices
- ⑧ 24 V DC input power supply
- ⑨ 24 V DC miniature circuit-breaker

Power supply of the
PS 4-101-DD1 and the
inputs/outputs

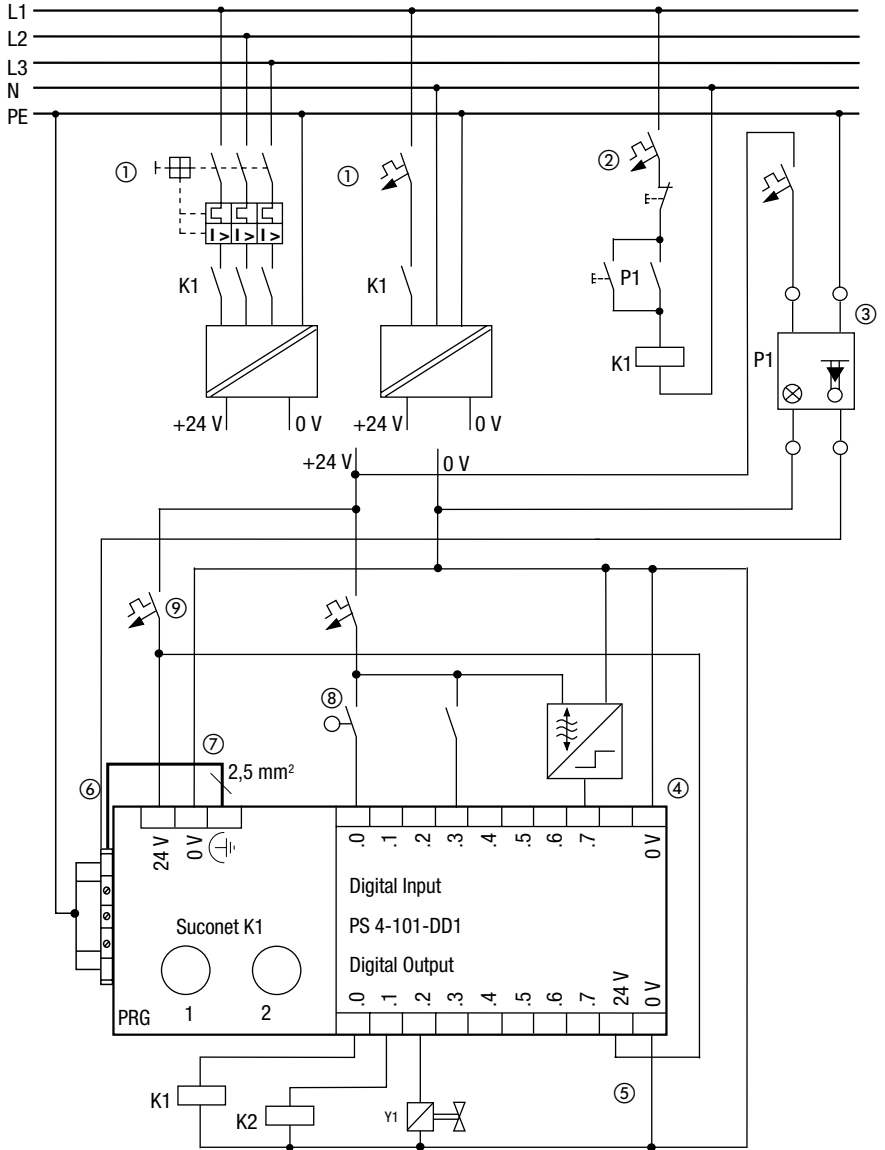

Figure 12: Common power supply, unearthed operation

Legend of figure 13:

- ① Protection of the power supply unit
- ② 0 V reference point for inputs
- ③ Power supply outputs
- ④ Power supply of the PS 4-101-DD1
- ⑤ Follow the instructions on page 30 Earthing the devices
- ⑥ 24 V DC power supply for inputs
- ⑦ 24 V DC miniature circuit-breaker

Power supply of the
PS 4-101-DD1 and the
inputs/outputs

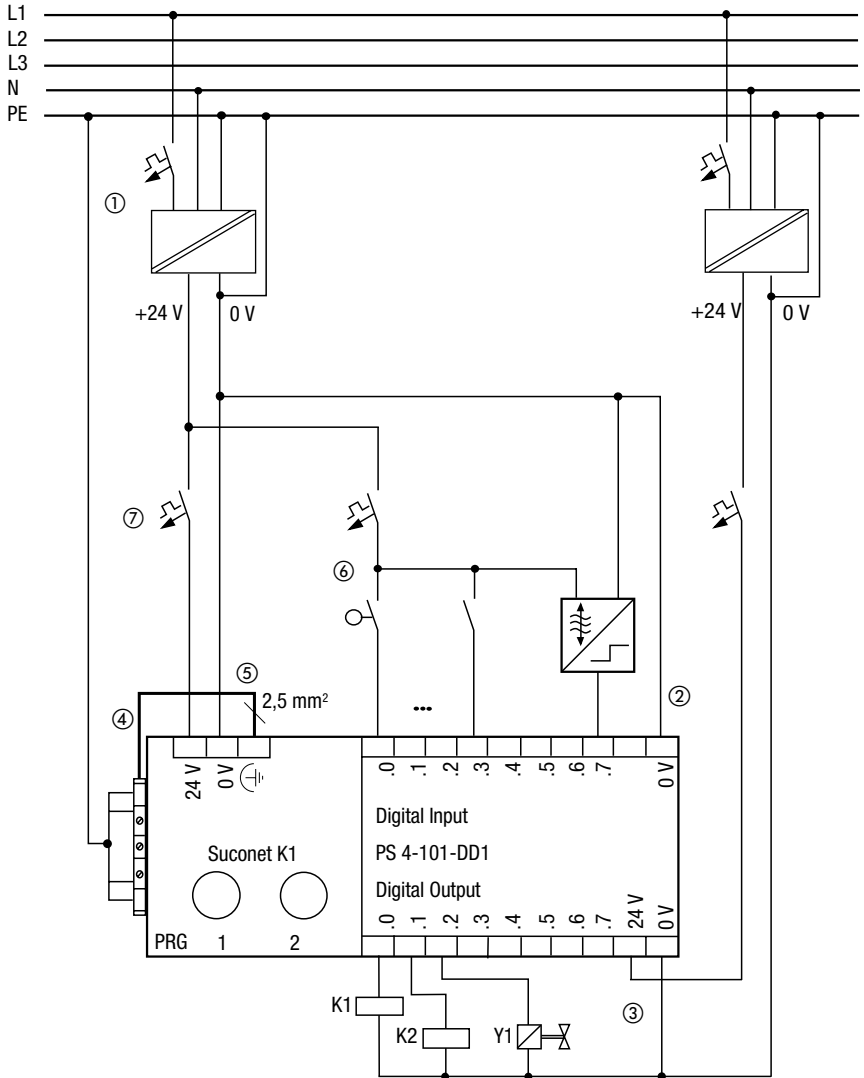

Figure 13: PS 4-101-DD1 and inputs with common power supply, outputs with own power supply, earthed operation

Power supply of the PS 4-111-DR1/DR5 and the inputs/outputs

The following power supplies are shown on the following pages:

Common power supply of the PS 4-111-DR1/DR5 and the relay outputs, the 24 V DC inputs are supplied via an internal power supply unit (figure 14).

Power supply of the PS 4-111-DR1/DR5, relay outputs with different potentials and 24 V DC inputs via an external power supply unit (figure 15).

Legend of figure 14:

- ① Main switch
- ② Miniature circuit-breaker
- ③ Protective conductor rail
- ④ 24 V DC output (max. 50 mA) for feeding inputs
- ⑤ 230 V AC relay outputs must be connected to the same phase (e.g. L1) such as the power supply of the PS 4-111-DR1/DR5
- ⑥ 4 A fast fuse for the protecting the relay contacts
- ⑦ PS 4-111-DR1/DR5 power supply
- ⑧ Follow the instructions on page 30 Earthing the devices

Power supply of the
PS 4-111-DR1/DR5 and
the inputs/outputs

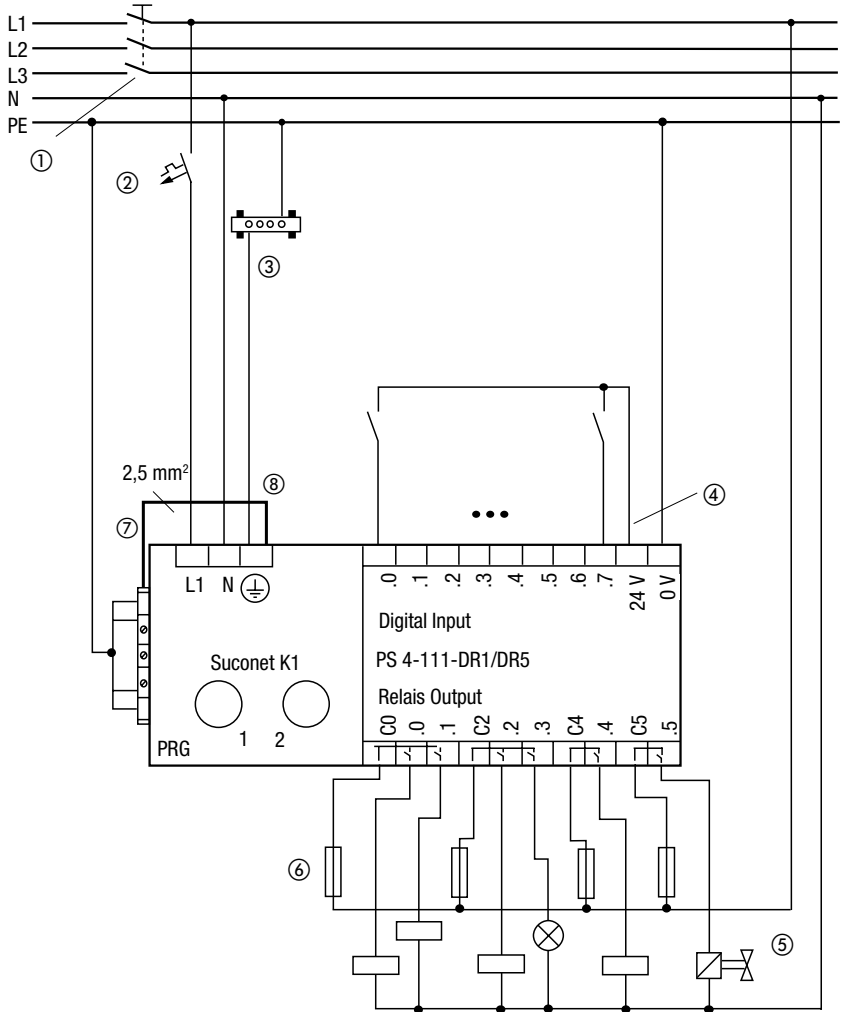

Figure 14: PS 4-111-DR1/DR5 and relay outputs with common power supply, 24 V DC inputs with internal power supply



When switching mains voltages as well as 24 V DC voltages, one relay group must remain disconnected between these two contacts in order to ensure air clearance and creepage distances (see figure 15).

Legend of figure 15:

- ① Main switch
 - ② Miniature circuit-breaker
 - ③ Protective conductor rail
 - ④ Miniature circuit-breaker
 - ⑤ Power supply unit to IEC 364-4-41 and VDE 0100 Part 410
 - ⑥ 230 V AC relay outputs must be connected to the same phase (e.g. L1) such as the power supply of the PS 4-111-DR1/DR5
 - ⑦ 4 A fast fuse for the protecting the relay contacts
 - ⑧ PS 4-111-DR1/DR5 power supply
 - ⑨ Follow the instructions on page 30 Earthing the devices
 - ⑩ Proximity switch
- *) see note at the top of this page

Power supply of the
PS 4-111-DR1/DR5 and
the inputs/outputs

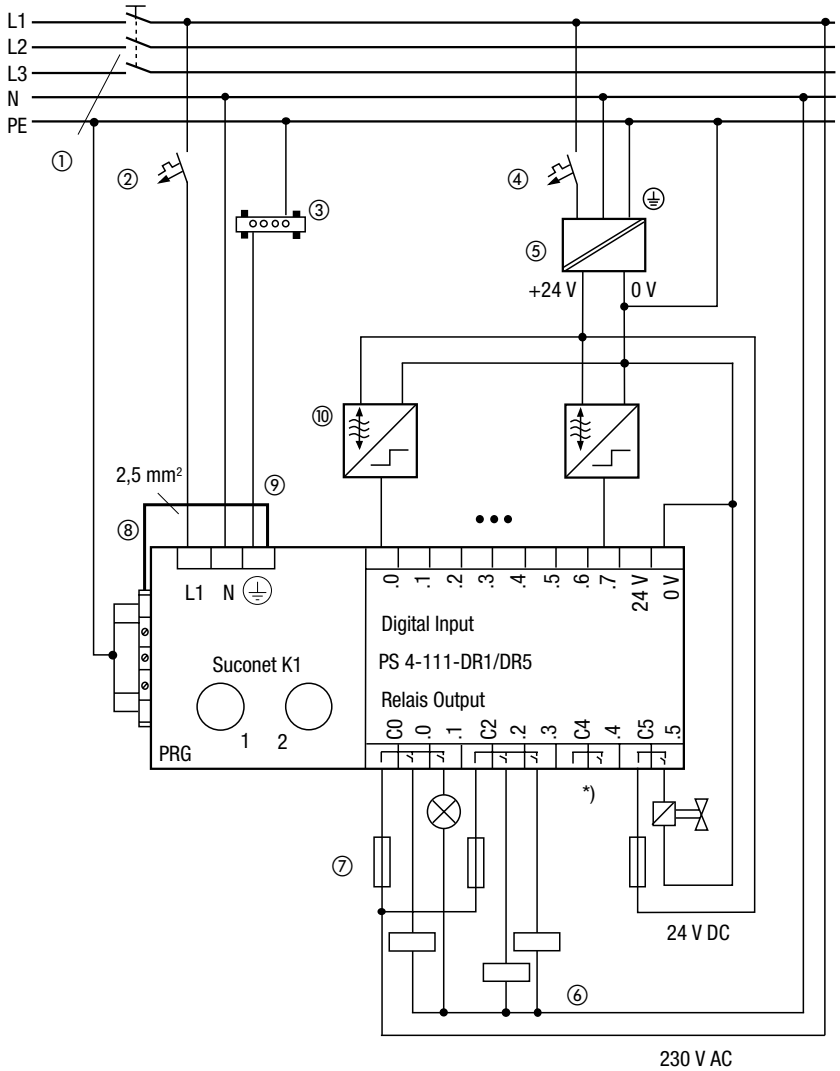

Figure 15: PS 4-111-DR1/DR5 power supply, relay outputs with different potentials, 24 V DC inputs via external power supply unit

Device earth

Mounting on top-hat rail

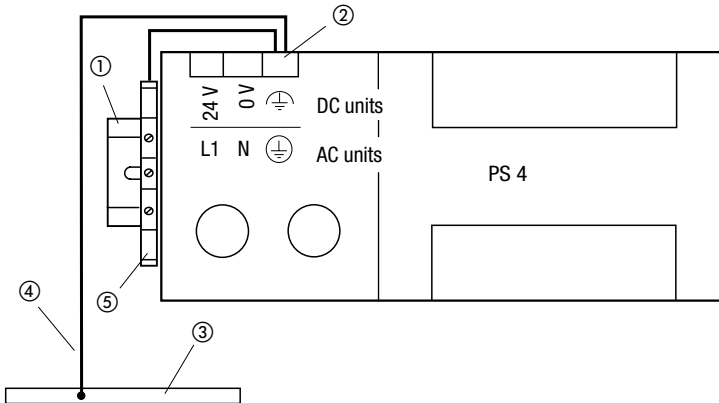

Figure 16: Device earth for mounting on top-hat rail

- ① Top-hat rail
- ② Function earth (for DC units)
Protective and function earth (for AC units)
- ③ Protective conductor rail
- ④ Connection only for AC units
- ⑤ Protective conductor terminal

DC units

Connect the earth to the reference potential contact via a protective conductor terminal and a top-hat rail (e.g. from Messrs. Weidmüller or Phoenix). The connection should be as short as possible and have a 2.5 mm^2 (AWG 13) cross section.

AC units

Connect the earth to the reference potential contact via a protective conductor terminal and a top-hat rail (e.g. from Messrs. Weidmüller or Phoenix). The connection should be as short as possible and have a cross section of 1.5^2 mm (AWG 16).

Connecting the programming devices

Connector assignment

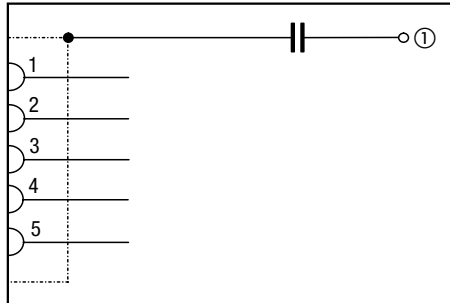

Figure 18: Connector assignment of Suconet K1 interface No. 1 (left interface) PRG

- Pin 1 RS 485 Suconet K1 (TB/RB) data cable
- Pin 2 free
- Pin 3 0 V of the PRG power supply
- Pin 4 RS 485 Suconet K1 (TA/RA) data cable
- Pin 5 +9 V DC of the PRG power supply
- ① Power supply earth connection

A capacitive coupling is used to connect the earth terminal of the power supply for the PS 4-100. The screen of the programming cable must be connected to the housing of the plug.

PRG 3 hand-held programming device

The PRG hand-held programming device is connected to the Suconet K1 interface No.1 (left interface) which supplies the 9 V DC 150 mA current for the PRG 3.



The PRG can be connected and disconnected during operation.

Personal Computer (PC)

Connect the PC via the EPC 335.1 PC interface card or the ZB 4-501-UM1 interface converter to the Suconet K1 interface No.1 (see also AWB 27-1158-GB, Chapter 1 Programming devices).



Note

If you connect the PC via the EPC 335.1 PC interface card or via the ZB 4-501-UM1 interface converter to the Suconet K1 interface No. 2, the protective conductors of the PLC and the PC must have the same earth potential in order to eliminate potential equalisation currents between the PC and PLC. Otherwise interference can occur or the PC interface card or the interface converter can be destroyed.

If there is no common earth potential the PC must be connected via an isolating transformer or the laptop must be run with an internal battery.

Connection to the Suconet K1 fieldbus

Connector assignment

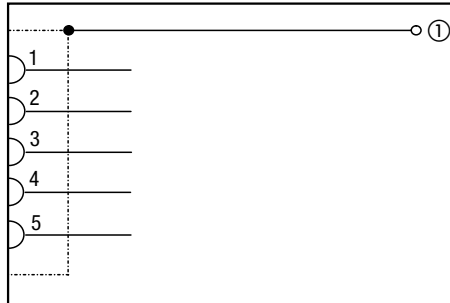

Figure 19: Socket assignment of the Suconet K1 interface No. 2 (right interface)

PIN 1 RS 485 Suconet K1 (TB/RB) data cable

PIN 2 free

PIN 3 free

PIN 4 RS 485 Suconet K1 (TA/RA) data cable

PIN 5 free

① Power supply earth connection

The housing socket is connected directly to the earth terminal of the PS 4-100 power supply. Connect the cable screen to the housing of the plug connector.

Interference measures

Cabling and wiring

Cables should be divided into the following categories:

Power cables (e.g. heavy current power supply cables, or cables to current converters, contactors, solenoid valves)

Control and signal cables (e.g. digital input cables)

Measuring and signal cables (e.g. fieldbus cables)



Power, control and signal cables must be laid as far apart from each other as possible in order to prevent capacitive and inductive coupling. If separate cabling is not possible then those cables that are the interference source must be screened without fail.

In order to keep interference to a minimum ensure that the cabling inside and outside of the control cabinet is carried out correctly. Proceed as follows:

- ▶ Avoid long, parallel cables with different power ratings.
- ▶ Separate AC voltage cables from DC cables.
- ▶ Keep the following minimum clearances:
 - min. 10 cm (approx. 4") between power cables and signal cables
 - min. 30 cm (approx. 12") between power cables and data/analog cables.
- ▶ When laying cables ensure that supply and return lines of a circuit are kept together. The opposing direction of current flow makes the sum of all currents 0, thus compensating all resulting fields.

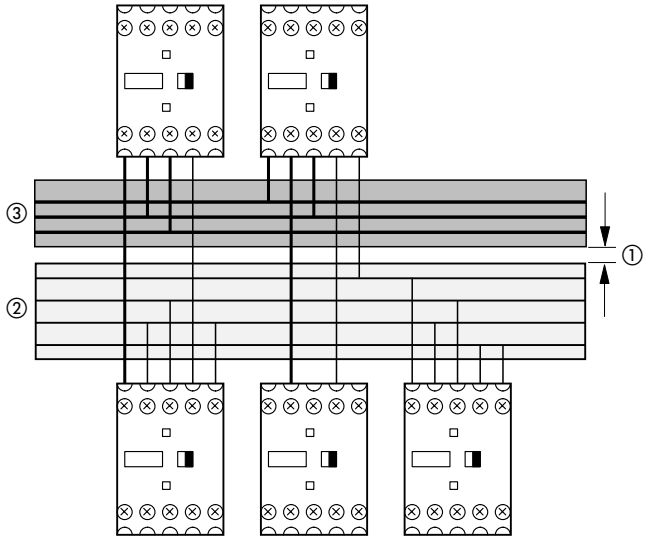

Figure 20: Separate cable ducts for AC and DC voltage

- ① The larger the gap, the better the effect
- ② 1 cable duct for 24 V
- ③ 1 cable duct for 380 V; 220 V

Legend of figure 21:

- ① Cover
- ② Communication cables
- ③ Cable duct
- ④ Measuring cables, analog cables
- ⑤ Control cables
- ⑥ Power cables
- ⑦ Continuous divider

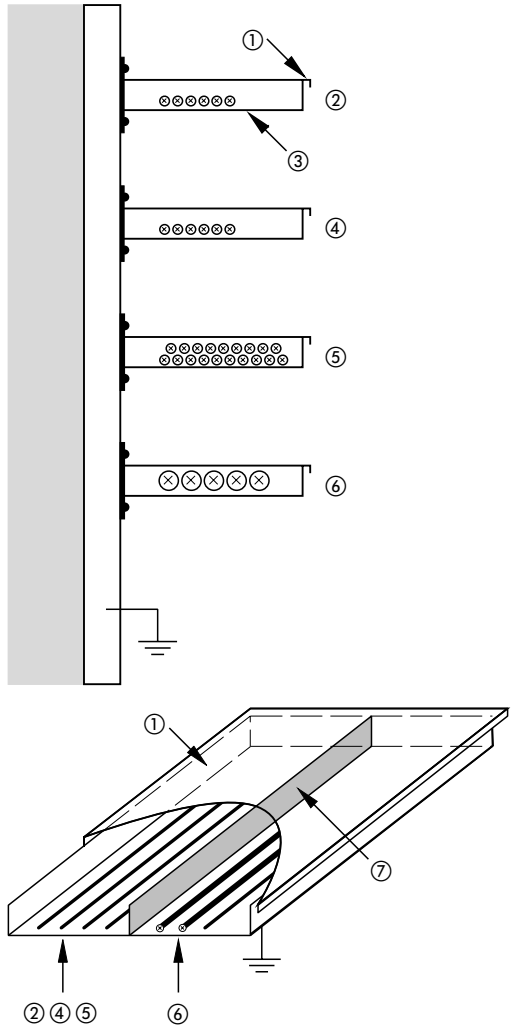

Figure 21: Separate routing of power and signal cables

Suppression of interference sources

All suppressor circuits must be installed as near to the interference source (contactor, relay, valve) as possible.



Switched inductive loads should always be provided with suppression circuits.

Screening

Use screened cables for the PS 4-100 when using the PRG terminal and the Suconet K1 interface.



Only a screen connection at both ends will ensure proper screen protection for capacitive and inductive interference.

Screening at both ends must be implemented with sufficient potential equalisation between both connection points. This is ensured by using short connections such as within control cabinets or within a control room (see earthing).

An additional potential equalisation conductor of at least 10 mm² cross section must be fitted parallel to the screen if the potential equalisation is not sufficient.

Digital signal cables, data transfer lines and cables from frequency inverters to the motor should be screened at both ends wherever possible.

Lightning protection

External lightning protection

All the incoming and outgoing cables of the building to be protected must be screened. Metal conduits are recommended for this.

Protective elements against overvoltage, such as varistors or other lightning arresters, are used for signal cables. The cables must be protected where they enter the building or at least at the control cabinet.

Internal lightning protection

Internal lightning protection includes all measures that reduce the effects of the lightning current and its electrical and magnetic fields on metallic installations and electrical systems inside a building. These measures include:

- Lightning protection potential equalisation

- Screening

- Use of overvoltage protection devices.

You can find further information in the Moeller manual TB 27-001-GB “Electromagnetic Compatibility (EMC) of Automation Systems”.

Networking

The PS 4-100 can be expanded via the Suconet K1 connection with all Suconet K1 compatible devices.

Suconet K1 fieldbus system

Suconet K1 is a serial fieldbus system where data is exchanged via a two-wire cable with a transmission speed of 187.5 kbaud (baud = bit/s). Suconet K1 is a hierarchical fieldbus system in which the bus master controls several slave stations, reads the inputs and writes the outputs.

The Suconet K1 interfaces of the PS 4-100 can be used as central and remote expansion interfaces.



The PS 4-100 is the Suconet K1 bus master.

Three bus stations can be connected to the Suconet K1 interface of a PS 4-100.

The PS 4-100 can read 48 inputs and write 24 outputs for each station. Suconet K1 stations using the high-speed counter module can be connected and are supported.

Communication data between master and slaves

Up to three slaves can be connected to the Suconet K1 interface of a PS 4-100 master controller. The PS 4-100 master uses the following communication data and operands to the slaves connected to the bus (see also AWB 27-1158-GB, Chapter "Basic Information").

1st slave station

Inputs:

I1.0–I1.15 (IB1.0, 1.8/IW1.0)	16 Inputs
IA1.0	8 Inputs
IA1.1	8 Inputs
IA1.2	8 Inputs
IA1.3	8 Inputs
Total no. of Inputs	48 Inputs

Outputs:

Q1.0–Q1.15 (QB1.0, 1,8/QW1.0)	16 Outputs
QA1.0	8 Outputs
Total no. of outputs	24 Outputs

2nd slave station

Inputs:

I2.0–I2.15 (IB2.0, 2.8/IW2.0)	16 Inputs
IA2.0	8 Inputs
IA2.1	8 Inputs
IA2.2	8 Inputs
IA2.3	8 Inputs
Total no. of Inputs	48 Inputs

Outputs:

Q2.0–Q2.15 (QB2.0, 2,8/QW1.0)	16 Outputs
QA2.0	8 Outputs
Total no. of outputs	24 Outputs

3rd slave station:

Inputs:

I3.0–I3.15 (IB3.0, 3.8/IW3.0)	16 Inputs
IA3.0	8 Inputs
IA3.1	8 Inputs
IA3.2	8 Inputs
IA3.3	8 Inputs
Total no. of Inputs	48 Inputs

Outputs:

Q3.–Q3.15 (QB3.0, 3,8/QW3.0)	16 Outputs
QA3.0	8 Outputs
Total no. of outputs	24 Outputs



The operands of the communication data are unrelated to the input/output type (digital or analog) of the slave station in question.

Example

A slave station has 24 inputs. I1.0 to I1.15 are assigned 16 digital inputs (operand and input type). The input byte IA1.0 (the common analog input) now has 8 digital inputs (see also AWB 27-1160-GB, Chapter “Communication”).

Central expansion with one bus station (Digital inputs and outputs)

In the following example 16 central inputs and 14 outputs are required. They are assigned to two devices. Their location and address is shown in figure 22.

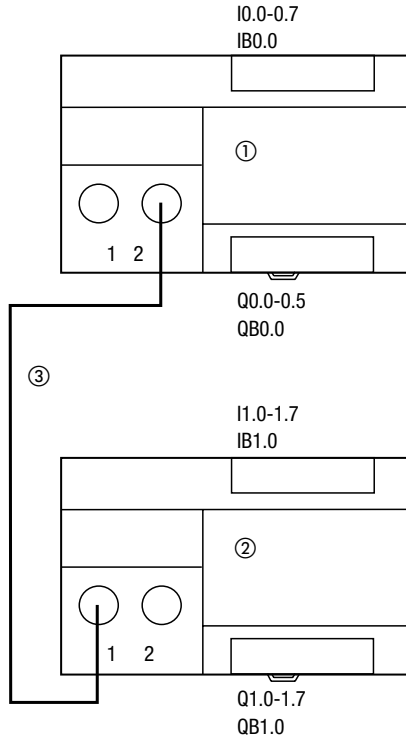
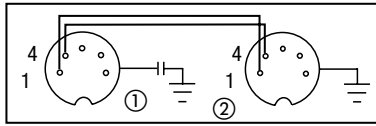
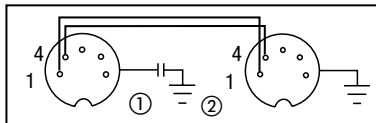
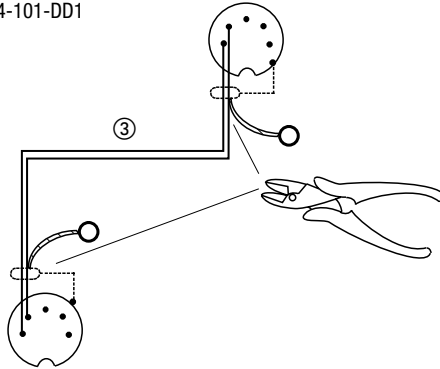

Figure 22: Central expansion with one bus station
(Digital inputs and outputs)

- ① Programmable logic controller (PS 4-101-DD1, 8I/6O)
- ② External module (EM 4-101-DD1),
digital inputs/outputs 8I/8O)
- ③ Suconet K connecting cable (KPG1-PS3), length 0.5 m



PS 4-101-DD1



EM 4-101-DD1

Figure 23: Screening of Suconet K and pin assignment

- ① Interface 1
- ② Interface 2
- ③ KPG1-PS3: This cable does not require the additional connection with the earth

Remote expansion with three bus stations (Digital inputs/outputs and analog inputs/outputs)

This example shows the controller equipped with 8 central inputs and 6 central outputs. 32 inputs and 24 outputs are required for the first expander unit. 8 inputs and 8 outputs are required for the second expander unit and the third expander unit uses the analogue inputs and outputs. The following figure shows the location of the inputs/ outputs and their address.



For more information on screening cables refer to the instructions in the section “Screening” on page 38.

Legend of figure 24:

- ① Programmable logic controller (PS 4-100)
- ② External module (EM 4-201-DX2, expandable, 16 digital inputs)
- ③ Local expansion (LE 4-116-DX1, 16 digital inputs)
- ④ Local expansion (LE 4-116-XD1, 16 digital outputs)
- ⑤ Local expansion (LE 4-116-XD1, 16 digital outputs)
- ⑥ External module (EM 4-101-DD1, 8 digital inputs/ outputs)
- ⑦ External module (EM 4-101-AA1, 6 analog outputs and 3 analog inputs available)

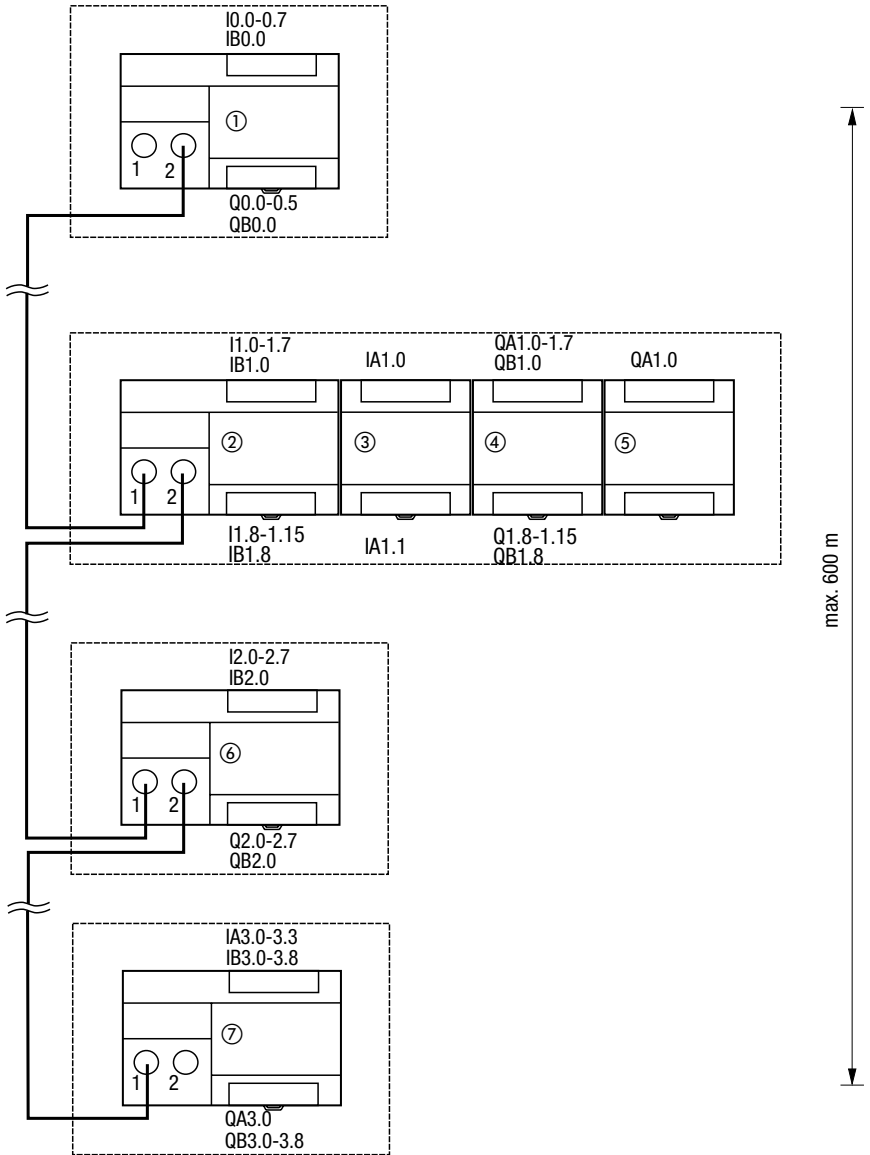

Figure 24: Remote expansion with three bus station (digital inputs/outputs and analog inputs/outputs)

Slave mode

The PS 4-100 has a Suconet K1 slave function which enables the slave to operate in passive and active mode. In “Passive slave” mode the PS 4-100 operates like the EM 4 modules.

Active slave

In the “Active slave” mode the PS 4-100 processes its own user program. Like a master controller, the local periphery is addressed directly. All resources (e.g. operands, system modules, commands) can be used, with only one exception: in the marker word 34.0 only the markers M34.0, M34.7, M34.8, M34.13, M34.14 and M34.15 can be used.

The remote data is exchanged with the master via Suconet K1. The master is addressed by the user program like the first slave.

Slave mode

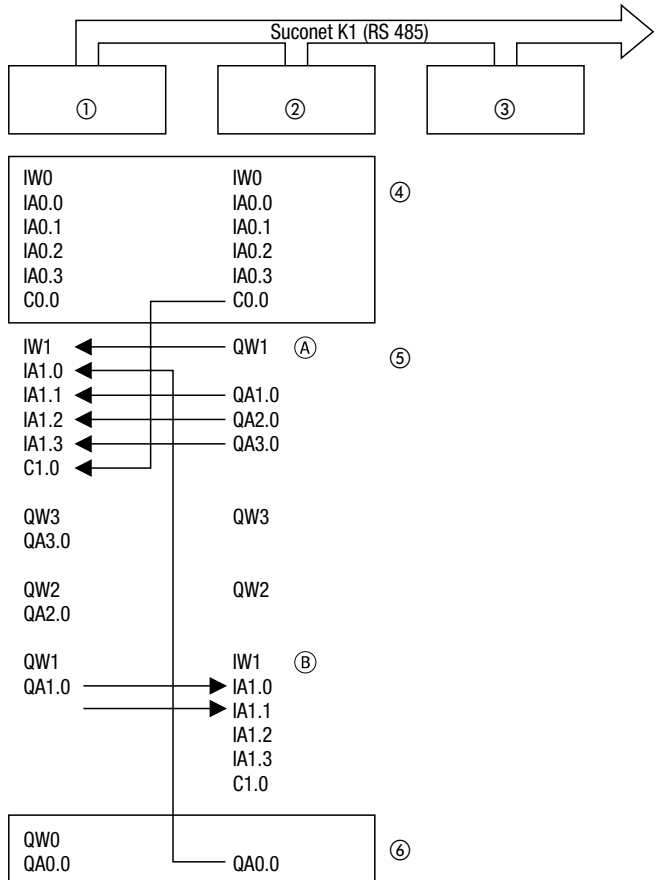

Figure 25: Communication between master and active slave

- Ⓐ Example 1
- Ⓑ Example 2
- ① Master PS 4
- ② 1st slave (active) PS 4-100
- ③ 2nd slave EM 4
- ④ Inputs
- ⑤ Communication
- ⑥ Outputs

Example

System network with one active slave

The figure 25 shows how the local inputs/outputs of the master and the active slave are addressed in the same way.

The remote data transfer between the master and the active slave is carried out via defined connections.

A particular slave output where the slave information is stored is thus assigned a particular master input on which the master can read and process this information.



Remember that the high-speed counters C0.0 in the active slave and C1.0 in the master cannot be used simultaneously but only alternately (see figure above).

Figure 25 contains the following examples:

Example 1

The content of the output word QW1 is to be sent from the active slave to the master.

IL program in the active slave:

```
L ...  
= QW1
```

The transferred data can then be further processed since the input word IW1 has been loaded in the master.

IL program in the master:

```
L IW1  
= ...
```

Example 2

The active slave is to receive the content of the output word QW1 in the input word IW1 and write the content into the marker word MW1. The output word QW1 must be assigned in the master.

IL program in the master:

```
L M...
= QW1
```

IL program in the active slave:

```
L IW1
= MW1
```

Active/passive slave setting

The PS 4-100 is factory set for operation as a master controller. This can be changed for passive or active slave operation via the S2 switch and the marker byte MB35.8.

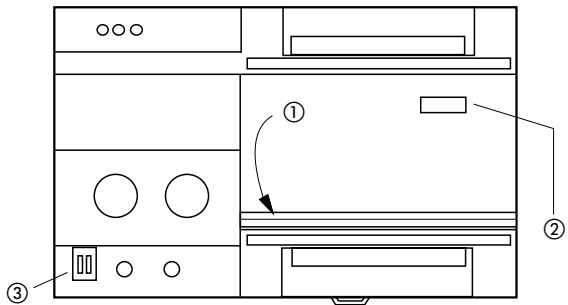

Figure 26: S1, S2 switches

- ① Open protecting cover
- ② S2 switch for master/slave setting
- ③ Suconet bus terminating resistor S1



The Suconet bus terminating resistor must be switched on at the physical beginning and end of the bus line.

Table 1: Master/slave setting

PS 4-100	S2
Master	closed
Slave	open

Marker byte MB35.8 (M35.8 – M35.15)

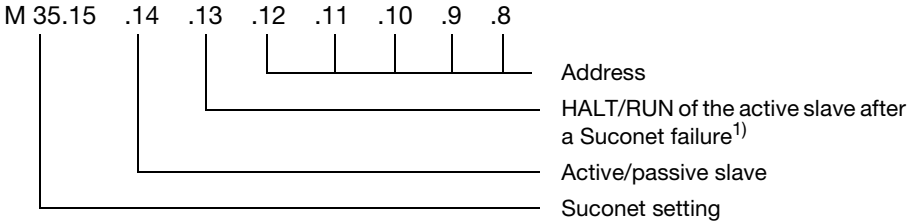

1) The Halt/Run marker bit M35.13 determines whether the active slave switches to Halt or Run when the Suconet line fails or when the master switches to HALT.

With the following settings for M35.13–M35.15:

- M35.13 = 1 Run operation
- M35.14 = 0 Active slave
- M35.15 = 1 Data exchange every nth cycle,

the active slave will start when the power supply is switched on, even if the Suconet network has failed or has been switched off, and will stay in Run even if the master has failed.

Marker bit M34.7 indicates a Suconet failure/switch off (“0” = Suconet OK; “1” = Suconet failure).

The states of the marker bits M35.8 to M35.12 define the slave address which can have a value from 2 to 31 (the value 1 is automatically assigned to the master). The first slave is assigned the address 2.

The Halt/Run marker bit **M35.13** determines whether the active slave switches to Halt or Run when the Suconet line fails or is switched off.

Status “0” means that the active slave switches to Halt when the Suconet line fails or is switched off.

Status “1” means that the active slave stays in Run when the Suconet line fails or is switched off.

The marker bit **M35.14** determines the slave mode:

status “0” active slave,

status “1” passive slave.

The marker bit **M35.15** sets the configuration for Suconet K1:

Status “0” means that Suconet K1 is active each cycle (synchronous mode),

Status “1” means that Suconet K1 is active only each nth cycle (asynchronous mode).

The slave mode is divided into two submodes since a program run in a PS 4-100 in active slave mode can be considerably smaller and thus with a shorter cycle time:

Synchronous mode

In synchronous mode the active slave waits until a complete data transfer cycle with the master controller has been completed. In this case the cycle time is constant and depends on the master controller (marker bit M35.15 is “0”).

Asynchronous mode

In asynchronous mode (marker bit M35.15 is “1”) a check is made as to whether a data transfer is requested. The user program continues to run until a request is present.

The cycle time is thus variable since it depends on either the user program or the user program together with the data transfer. This results in a mean cycle time which generally is considerably shorter than the cycle time in the synchronous mode.

Example of the MB35.8 marker byte setting:

The PS 4-111-DR1/DR5 is to be active slave and the third slave station (address = 4) in the Suconet K1 network and Suconet should run every nth cycle. The PS 4-111-DR1/DR5 should also switch to Halt in the event of a Suconet failure/switch off. The marker byte MB35.8 has the following states:

.15	.14	.13	.12	.11	.10	.9	.8	
1	0	0	0	0	1	0	0	
nth cycle	Active slave	Status after Suconet line failure/switch off	Address 4					

The IL instruction is:

```
L KB 132
= MB35.8
```

Transferring the MB35.8 marker byte to the controller

The MB35.8 marker byte can only be transferred to the PS 4-100 controller for active/passive slave mode setting if the controller is temporarily set as master, i.e. the S2 switch must be temporarily closed beforehand. In this state ensure that the slave is disconnected from the network (in order to avoid collisions with the real network master).

Proceed as follows in order to transfer the user program to the controller:

- ▶ Select the System selection menu in the main menu of Sucosoft S 30-S3 via the function key [F7].
- ▶ Press the [F2] MSDOS WINDOW key.
- ▶ Enter under Name: MAKESLAV and under Argument: the name of your user program (e.g. TEST).

S U C O S O F T S 30

MS DOS WINDOW

Name : makeslav _____

Argument: test _____

RETURN VIA F1 to F10

Path : C:\PS3\U23

- ▶ Now change to the “Transfer” menu and transfer the program to the controller.
- ▶ Switch the PLC into the RUN status.
- ▶ Switch off the power supply.

The following steps are necessary so that the controller runs in the slave mode:

- ▶ Open the S2 switch.
- ▶ Connect the Suconet station to the bus.
- ▶ Switch on the power supply.

A PS 4-100 which is implemented as an active slave is also programmed and tested in the master function. S2 switch must be closed for this.

After you have opened the S2 switch again and switched the power supply for the controller off and on, the controller starts to run in the active slave mode.

In the event of a Suconet K1 failure, the active slave goes to the Halt status like a passive slave. In the Halt status, however, the active slave does not change to passive mode. This does not permit a “HARDWARE TEST”.



All PS 4-100 controllers can be implemented as active slaves.

The settings in the marker byte 35.8 are retentive and are kept until they are overwritten. This marker byte can be read and also be reset in the “battery hours counter” status.

Example program with an active slave:

```

00000 "PROGRAM FOR ACTIVE SLAVE (PS4-101)
      1
      2 "-----
      3 "Initialisation Slave Mode
      4 "-----
      5 "Meaning of the parameters:
      6
      7 "M35.8 to M35.12      Address Slave
      8 "M35.14              0 = active Slave/1 = passive Slave
      9 "M35.15              0 = SYNC-1/1 = SYNC-n cycles
     10 "                    this setting can be modified
     11 "                    dynamically
     12
     13 L KB 2
     14 = MB35.8              Special marker: Adress Slave
     15
     16 L K 0
     17 = M 35.14             Slave-Mode: 0 = active/1 = passive (PS4)
     18 L K 1
     19 = M 35.15             Cycle: 0 = SYNC-1/1 = SYNC-n cycles
     20

00001 "Example program for Suconet-communication
      1 "of an active slave
      2
      3 "Receive data from Master
      4 "-----
      5 L IW1.0              Receive: QW1 in Master
      6 = QW0.0              Slave Output digital (6 x Q)
      7
      8 L IA1.0              Slave Trimmer 0
      9 = MB11.0
     10
     11 "Send data to Master
     12 "-----
     13 L IW0.0              Slave Input digital (8 x I)
     14 = QW1.0              Send: IW1 in Master
     15
     16 L IA0.0              Slave Trimmer 0 on IA0.0
     17 = QA0.0              Send: IA1.0 in Master
     18
     19 L IA0.1              Slave Trimmer 1 on IA0.1
     20 = QA1.0              Send: IA1.1 in Master
     21
     22 L MB10.0
     23 = QA2.0              Send: IA1.2 in Master
     24

```

Engineering

```
25 L MB10.8
26 = QA3.0          Send: IA1.3 in Master
27
28 "-----
29 "High-speed counter (C0.0) in Slave
30 "-----
31 C0.0
32 S: K 1
33 I: KW 4
34 Q: MW20.0
35
36 EP
37
*****      End of Program      *****
```

3 Operation of the PS 4-100

Hardware

The following pages give an overview of particular elements of the PS 4-100 hardware which are:

- CPU
- Memory
- Interface
- Inputs/outputs
- Power supply unit

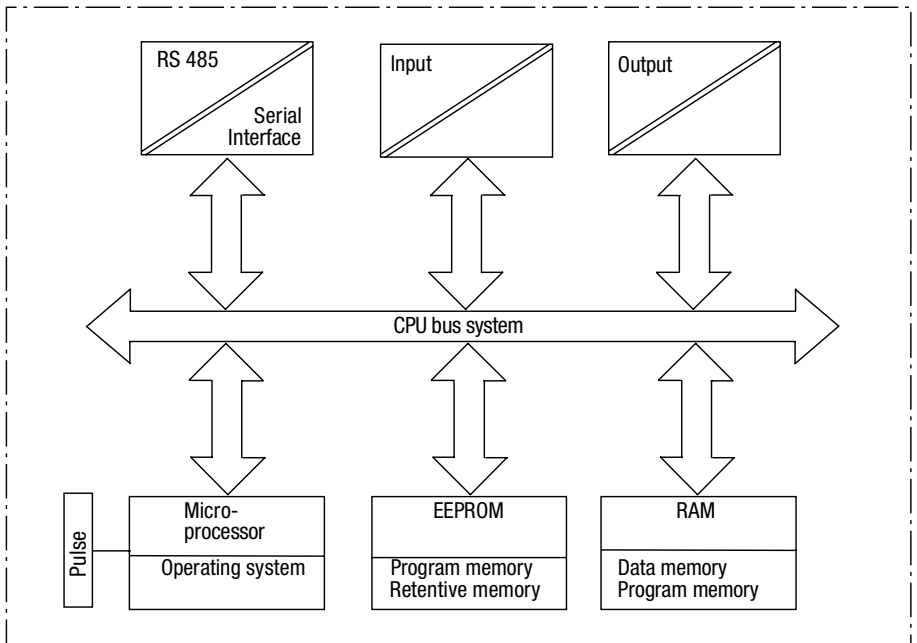

Figure 27: Hardware block diagram

Microprocessor

The microprocessor of the PS 4-100 is a mask processor which contains the operating system of the programmable logic controller. The controller thus does not contain an external operating system memory.

The operating system contains the initialisation, the communication and the operation of the inputs/outputs, as well as the program modules. Furthermore, the internal watchdog of the microprocessor is used to monitor the user program for cycle time violations.

Three status LEDs indicate the control states. The processor is completely isolated from the periphery.

Memory

The PS 4-100 has two memories:

EEPROM memory for saving the program and the retentive data after switching off the power supply

RAM memory which contains the user program as well as all operation data when the PLC is running.

The EEPROM memory is necessary since the PS 4-100 does not contain a backup battery, thus eliminating any required maintenance by the user. The EEPROM has a service life of 100 000 cycles.

Transfer the user program to the controller with a transfer operation from the PC (Sucosoft) or from the PRG programming device, and written to the EEPROM with the first switch-off after the transfer. The retentive data is written to the EEPROM each time the device is switched off.

Serial interface

The PS 4-100 has an RS 485 serial interface which is used for networking with Suconet K1 stations and for programming.

Socket 1 can be used as a programming interface as well as a networking interface; socket 2 only as networking interface. The interface is potentially isolated via optocouplers. The PRG 3 and the PC are the programmer stations. All Suconet K1 stations, e.g. the external modules of the EM 4, are considered as network stations.

Inputs/outputs

The PS 4-100 has 8 inputs and 6 outputs which are potentially isolated from the CPU, like the RS 485 interface. The inputs/outputs must be supplied separately. The inputs are designed for 24 V DC.

The outputs of the **PS 4-101-DD1** are also designed for 24 V DC and supply a maximum output current of 0.5 A. They are short-circuit and overload proof.

The **PS 4-111-DR1/DR5** has relay outputs which can be short-circuit protected with a 4 A fast fuse and thus against possible contact welding. LEDs which are physically coupled with the inputs/outputs indicate the input/output status.

Setpoint potentiometers

Two setpoint potentiometers are additional inputs of the device which can be operated by the user. These setpoint potentiometers are connected with the analog input of the processor. An analog/ digital conversion provides the user with digital values. Both potentiometers are accurate to $\pm 10\%$ of the set value.

High-speed counter

Another special feature of the inputs is input I0.0. This input can also be used as a high-speed counter which can process events at up to 3 kHz. Unlike the other inputs the counter input is processed by the interrupt system of the processor. This ensures the functioning of the high-speed counter also in long user programs.

Power supply unit

The power supply unit of the **PS 4-101-DD1** is a DC unit which provides two kinds of supply voltages for the central unit and the potentially isolated units. The power supply unit also generates the signals "Power Fail" and "Reset" which are necessary for switching off the system. The microprocessor uses these signals for initialisation and data security.

The power supply unit of the **PS 4-111-DR1/DR5** is an AC unit which can be supplied with a voltage from 120 V AC up to 230 V AC. This power supply unit supplies the central unit and the potentially isolated units, such as 24 V DC inputs, PRG, Suconet K1 interface and the control of the relays.

The power supply unit also generates the signals "Power Fail" and "Reset" which are necessary for switching off the system. The microprocessor uses these signals for initialisation and data security.

Software

A control system requires the interaction of several software components. Since the central unit can process only one program at a time, this time must be distributed between the individual components.

The processing of an individual component can
result from a sequence,
be controlled by an external event or
be repeated at fixed time interval.

The software components can roughly be divided into system and user software.

System software

The system software is provided with the controller for use with all applications all basic functions of the control system. The system software is stored in the mask of the processor of the CPU and there protected against unauthorized access.

The system software has a version number to distinguish the status of the software. The number can be called up with the programming device.

The system software of the PS 4-100 contains the following basic functions.

Self test when starting

Initialisation

- initialisation of the CPU

- determining the remote stations present

- copying the user program from the backup memory (EEPROM) into the working memory

- copying retentive data from the backup memory (EEPROM) into the working memory

- determining the start up behaviour (RESTART)

Monitoring and control of

- bus activities

- cycle time (watchdog)

- power supply

Processing the user program

- cyclical system time

- generating the basic time pulses (timer)

- executing the function modules

Data transfer

- between the programming device (PRG 3) and the controller

- between the remote station (Suconet K1 slave) and the controller

Test aids and diagnostics

- monitoring of the operand status in the system time (status display with PC)

- monitoring the result register (bit, byte word accumulator) at certain positions of the user program (status display with PRG 3)

- diagnostics possible via PS status

User software

The user software is specially written for the control task at hand. It consists of the programming language and system module (function block) calls.

The user software is programmed on the PRG 3 programming device or on the PC using Sucosoft S 30-S3. If the program does not have any syntax errors it is converted into a code in the programming device which the central unit is able to execute. The user program consists of the code together with the program header with information on the used system modules and the number of remote stations. The user program is loaded into the working register on the central unit (TRANSFER) and executed there by the microprocessor in RUN status.

Interaction of the software components

The user program is always started from the system software. The system program starts a user cycle when all activities required in the system are processed.

The cyclical processing of the user program is interrupted for a short time by event-driven system programs. These interruptions enable several functions to run virtually simultaneously. The event-driven functions supported by the system software in the RUN status are the following:

- cycle time monitoring
- processing the basic time pulses
- processing the high-speed counter in the event of a predivider overflow
- operating the programming devices and remote inputs/outputs communication. The data transfer

is determined by the Suconet K1 data transfer protocol.

monitoring the power supply with backup for retentive data.

The cyclical processing of the user program can also be interrupted by programmable interruptions. These initiate a system call and thus pass the control to the system program. The system modules and the "EP" instruction are programmable interruptions.

When programming with the PRG 3, the "EP" instruction is invisible, i.e. it is set automatically behind the last instruction of the user program. The "EP" system call terminates the user program cycle and starts the processing of the required system activities (system time).

Description of the functions

The operation states of the PS 4-100 are displayed with the POWER and RUN LEDs.

After switching on the power supply the operating system checks and initializes the hardware components of the PS 4-100. If the operating system does not detect any hardware errors the user program and the retentive data are copied from the backup memory (EEPROM) to the working memory of the PLC. HALT mode or HALT NOT READY mode is selected depending on the errors concerned.

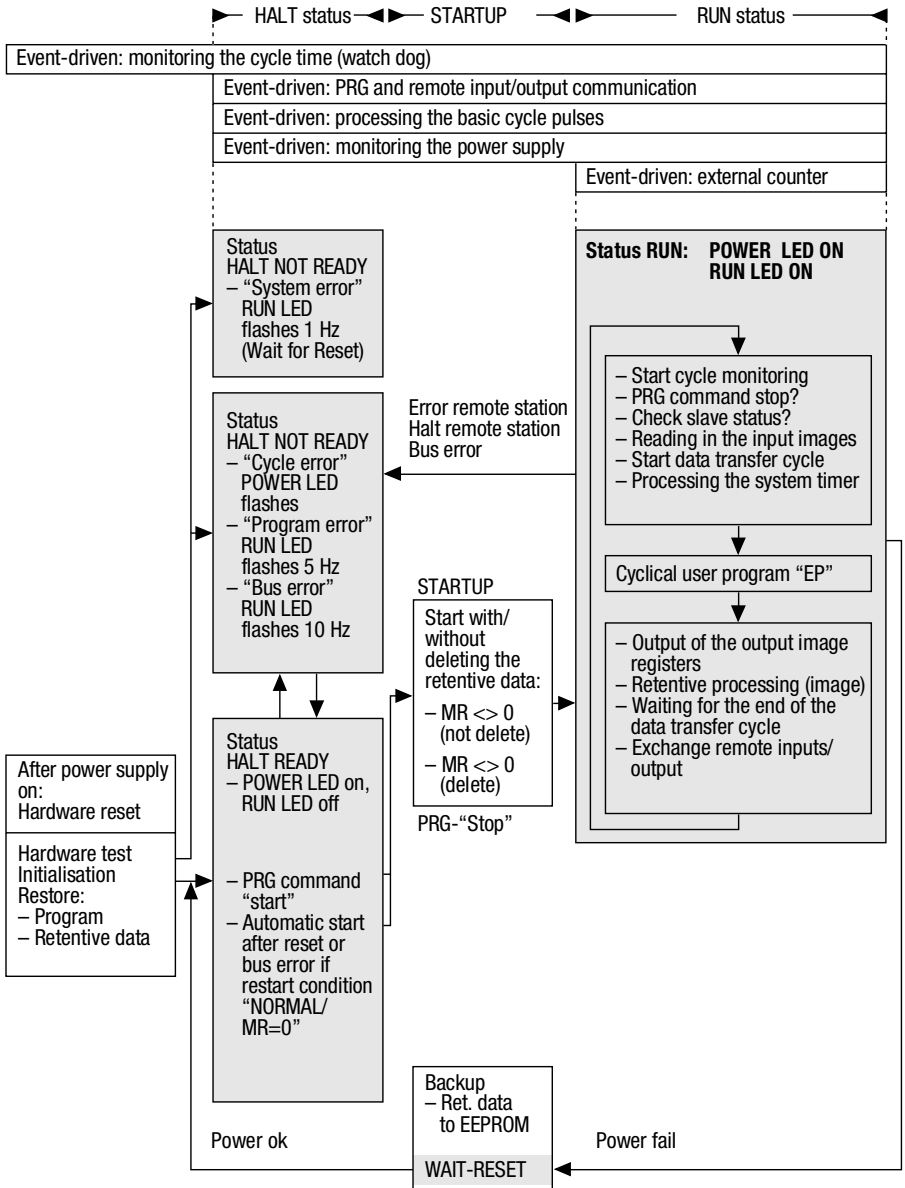

Figure 28: Description of the functions

Operating status HALT

The operating status HALT has the following features:

The user program is not run.

The output image registers are cleared when switching to the HALT status.

The local and remote input/output image register is refreshed after each cycle in order to support the "Hardware Test" PRG functions.

The user timers are stopped.

The remote input/output bus is operated cyclically thus enabling the functioning of the bus monitoring also in the HALT status.

The PRG communication (Start/stop, transfer, diagnosis) runs.

The machine switches to the HALT status

Due to a power failure with the restart condition "STOP",

in the event of an error (NOT READY),

after removing the bus error with the restart, condition "STOP",

by a user operation (PRG)

The PLC switches to the HALT NOT READY status if an error-free run of the user program is no longer ensured. The machine switches to this status in the event of the following errors:

System errors

A hardware error has been detected. In this status the RUN LED flashes at 1 Hz. This status can only be left by switching on/off the power supply.

Program errors

The user program in the user and the backup memory has been destroyed or deleted. The transfer of a program consisting of a NOP instruction (NOP) causes the deletion of a program. In this status the RUN LED flashes at 5 Hz. This status can only be left by transferring a valid program.

Cycle errors

The cycle monitoring carried out by the computer (watchdog) has given an error message. The POWER LED flashes to indicate this error status. This status can be left by switching on/off the power supply or by a PRG command (start/stop or transfer).

Bus errors

The remote slaves used in the user program do not exist. In this status the RUN LED flashes at 10 Hz for. This status is left automatically after the of the error is rectified.

Operating status STARTUP

The operating status STARTUP is the transition from the operating status HALT to the operation status RUN. The system program features the following startup modes, depending on the setting of the restart condition:

MR = 0

Cold-start without retentive markers and without retentive system modules

MR <> 0

Start with retentive markers (MW26 – MW33) and four retentive system modules, specified by MB35.0.

All data which is not retentive is deleted when changing from HALT status to RUN status.

Operating status RUN

The programmable logic controllers primarily work with the cyclical program processing. The processor processes the cyclical user program continuously in cycles. The next cycle starts at the program start if the program is processed.

The system program performs the following activities in each cycle depending on the task at hand:

Triggering the cycle-time monitoring

Processing the PRG command

Checking the status of the remote stations

Backup of the user program after a program transfer. This system program copies each 5 ms 32 bytes out of the working memory to the backup memory.

Reading in the process image of the local and remote inputs

Starting the next communication cycle

Processing the “Timer” and “High-speed counter” system modules on I0.0

Processing the cyclical user program

Output of the process image of the local and remote outputs

Synchronisation of the PLC cycle and the communication cycle

Data consistency for retentive markers. In order to keep the data consistency of the markers in the event of a voltage drop a double marker image is stored during the system time when restart condition $MR \lt; \gt; 0$. In the event of a voltage drop the image is copied to the EEPROM.

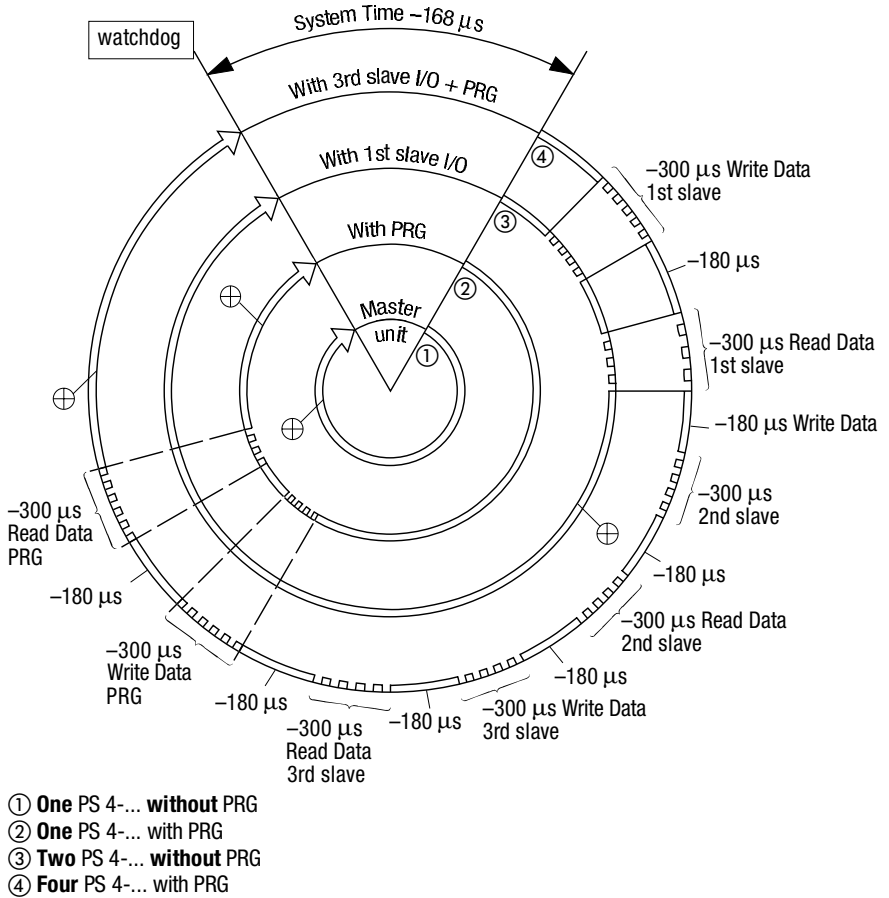

◻◻◻◻ = User memory

Figure 29: Processing the program cycle

The system time is variable and depends on the length of the user program. The system time with the restart setting $MR = 0$ (without PRG and without slaves) is $168 \mu\text{s}$. Unused functions are not processed in the system time.

Example

The system time with the restart setting $MR \neq 0$ (without PRG and without slaves) is $278 \mu\text{s}$. The retentive image function is not included in the setting restart $MR = 0$. This causes a reduction of the system time by $110 \mu\text{s}$ to $168 \mu\text{s}$.

The process image register is a memory range whose contents is output to the periphery or read in from the periphery once during each cycle. Before the start of the cycle the process inputs are read into the input image register by the system in byte format. This ensures that the status of the inputs is kept if they are scanned several times in one cycle. In operation, the user program only accesses these images. At the end of the program cycle the output images are output in byte format to the process. This prevents multiple bouncing of the outputs when setting and resetting them several times.

The use of image registers creates the external impression that the program data is being processed in parallel although the program is processed serially.

The process image contains inputs/outputs of the digital local and the digital remote periphery.

The local periphery is addressed via the local input/output bus. The inputs/outputs are transferred from/to the image register and from/to the process.

The remote periphery runs via the Suconet K1 communication protocol. The data exchange between the remote stations is actually carried out in the system time. The PLC and communication cycle runs synchronously.

The cyclical process is aborted

in the event of a power failure

in the event of a bus error or an error in the status of the remote stations

by the user (PRG)

Configuration/ Retentive function

The user can define the retentive behaviour of the system modules according to his requirements when configuring the PS 4-100. This enables the user to save the data of the application at hand if the voltage is switched off or in the event of a voltage drop. The retentive behaviour is set in the MB35.0 marker byte which is divided into four ranges (retentive parameters).

The MB35.0 marker byte has the following basic settings:

Default = 00 00 00 00 (00 = no retentive function)

Enter the coding in MB35.0 according to the module you wish to set retentively. The sequence is optional. Only the decimal value is changed.



Up to four modules can be set retentively: either the first four module numbers of one module type or the first module numbers of different module types.

Table 2: Coding table of retentive system modules

Module type	Retentive module number	Coding (retentive parameters)
Timer (T)	TR0 ... TR3	01
Counter (C)	C0 ... C3	10
Shift register (SR)	SR0 ... SR3	11

Example 1

1 retentive shift register, 3 retentive timers

11 01 01 01 → decimal value 213 in MB35.0

IL:

L KB213
= MB35.0

Example 2

2 retentive counters, 2 retentive shift registers

10 10 11 11 → decimal value 175 in MB35.0

IL:

L KB175
= MB35.0

In order to activate the retentive function in the controller the restart condition of the PLC must be set accordingly. The following three procedures are possible:

The controller always starts with reset data (MR = 0).

The controller starts with the retentive data not equal zero (MR <> 0).

The controller changes to the HALT status (Stop) after being switched on.

These settings are carried out either via the PC with the Sucosoft programming software or via the PRG 3.



Note

With Sucosoft and PRG 3 the set retentive function is displayed in battery hours. Resetting the battery hours causes the loss of the retentive behaviour and with this the retentive data of the PS 4-100.

The user can also control the retentive function with the 34.12 and 34.13 initialisation markers during a program transfer.

A “1” in the 34.13 marker means that all data is saved after a transfer. This setting has priority over the 34.12 marker. With a “1” all retentively set data is saved depending on the start condition.

A “0” means that the setting of the 34.12. marker is checked. All data is deleted if a “0” is entered in the 34.12 marker.



Note

If the data fields between the old and the new user program are inconsistent all data is deleted irrespective of the settings in the markers 34.12 and 34.13.

Example

All data should be kept after a program transfer.

IL:

L K1
= M34.13

The configuration of the PS 4-100 also includes two ranges which are only indirectly accessible to the user. These configurations are:

1. Generating the topology in the Suconet K1 operation when the slaves are connected to the PS 4-100.
2. Memory allocation of the user program.

Configuration 1

The compiler generates independently the configuration of the connected Suconet stations out of the user program so that the user does not need to deal with this task.

Configuration 2

The user can also control the memory allocation in the PS 4-100. The memory range of the PS 4-100 is organized dynamically according to the size of the user program and the number of the used system modules. A memory range is reserved for the system modules according to the highest number of a used system module. In order to keep free a memory area as large as possible for the user program the system modules should always be numbered consecutively in ascending order.

4 Description of Errors/Diagnostics

Diagnostics displays

Status LEDs

The LEDs facilitate fast and user-friendly diagnosis of the PLC. The status of the inputs/outputs can be recognized easily.

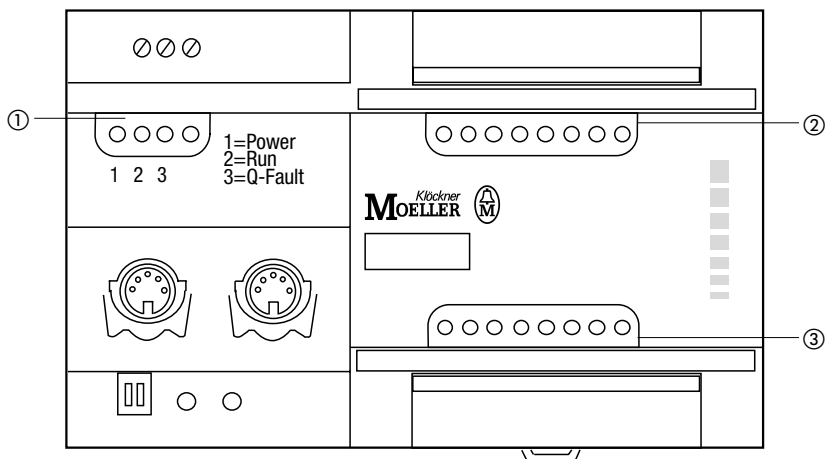

Figure 30: LEDs of the controller

- ① PLC status
- ② Input status
- ③ Output status

Table 3: Meaning of the LEDs

LED	Status Display	Meaning
POWER	off on (green)	Voltage supply off Voltage supply on
RUN	off on (green)	Controller is in HALT status Controller is in RUN status, the user program is processed
Q-FAULT*	off on (flashes)	All outputs are OK Error on the outputs
Input status	off on (green)	Input not activated Input activated
Output status	off on (green)	Output not activated Output activated

* only with PS 4-101-DD1

You can find further signal descriptions in the Programming manual AWB 27-1158-GB, Chapter 3 “Diagnostic messages”.

Appendix

Accessories

	Type	Equipment/Application
Installation/Mounting		
Fixing bracket	ZB 4-101 -GF 1	For screwing the PS 4-100 on the mounting plate
Input simulator	ZB 4-108-ES 1	Simulator for digital inputs
Memory module	EE 1-PS 3	Memory module for the PS 4-100 for saving up to 2 programs
Data cable	KPG 1-PS 3	Cable between PS 4-100 and EM 4
Data cable	KPG 2-PST 3	2 m connecting cable between PS 4-100 and PRG 3
PC cable	KPG 3-PS 3	Cable for the connection to a PC
Data plug	S 1-PS 3	5-pole DIN plug for the RS 485 interface of the PS 4-100
Terminal	ZB4-110-KL1	Screw terminal for input/output level
Programming		
Hand-held programmer	PRG 3	Manual and connection cable included
Sucosoft	S 30-S 3	Software for the operation with an IBM compatible DOS computer
Plug-in power supply unit	NG-PRG 3	Supply unit for the stand-alone operation of the PRG 3
Interface converter	ZB 4-500-UM 1	Interface converter for programming with the PC

Dimensions

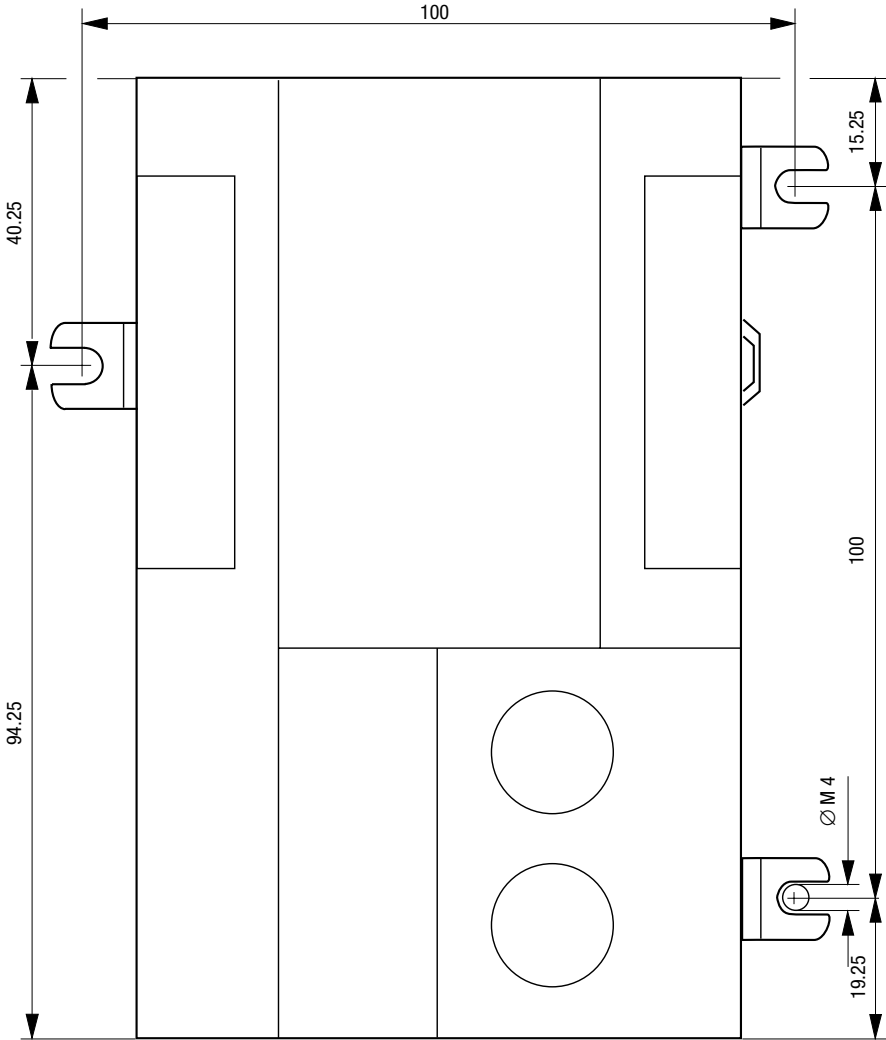

Technical Data

	PS 4-101-DD1	PS 4-111-DR1/ PS 4-111-DR5
General		
Standards, regulations	EN 61 131-2, EN 50178	EN 61 131-2, EN 50178
Ambient temperature	0 to 55 °C	0 to 55 °C/-25 to 55 °C
Storage temperature	-20 to 70 °C	-20 to 70 °C/-25 to 70 °C
Vibration resistance	constant 1 g, f = 0 to 150 Hz	constant 1 g, f = 0 to 150 Hz
Shock resistance	15 g/11 ms	15 g/11 ms
EMC	see page 85	see page 85
Operating mode	Master/Slave	Master/Slave
Degree of protection	IP 20	IP 20
Rated insulation voltage U_i	600 V AC	1500 V AC
Programming interface	RS 232 with ZB 4-501-UM1	RS 232 with ZB 4-501-UM1
Memory		
Program and data memory (internal)/ Backup memory	3.6 Kbyte RAM/3.6 Kbyte EEPROM	
Normal cycle time for 1 k instructions (Bit, Byte)	5 ms	5 ms
Max. number of inputs (local)	8	8
Max. number of outputs (local)	6	6
Max. number of inputs/outputs (remote)	230 via Suconet K1 line addressable	
Weight	approx. 450 g	approx. 450 g
Power supply terminals	Screw terminal	Screw terminal
Connection cross section		
flexible with ferrule	0.22 to 2.5 mm ² (AWG 23 to 13)	0.22 to 2.5 mm ² (AWG 23 to 13)
solid	0.22 to 2.5 mm ² (AWG 23 to 13)	0.22 to 2.5 mm ² (AWG 23 to 13)
Terminals input/output	Plug-in screw terminal	Plug-in screw terminal
Connection cross section		
flexible with ferrule	0.22 to 1.5 mm ² (AWG 23 to 16)	0.22 to 1.5 mm ² (AWG 23 to 16)
solid	0.22 to 2.5 mm ² (AWG 23 to 13)	0.22 to 2.5 mm ² (AWG 23 to 13)

Appendix

	PS 4-101-DD1	PS 4-111-DR1/ PS 4-111-DR5
Networking		
Expandable (remotely)	max. 3 slaves	max. 3 slaves
Network interface	RS 485	RS 485
Bus	Suconet K1	Suconet K1
Data cable length	600 m	600 m
Transfer rate	187.5 kBit/s	187.5 kBit/s
Power supply		
Rated voltage U_e	24 V DC	115 to 230 V AC
Permissible range	20.4 to 28.8 V DC	98 to 264 V AC
Rated frequency F_n	–	47 to 63 Hz
Residual ripple of input voltage	< 5 %	–
Reverse polarity protection	Yes	–
Rated current I_e	200 mA	50 mA
Inrush current and duration	3 A for max. 5 ms	< 12 A with 235 V AC
Power consumption	approx. 5 W	approx. 8.5 W
Bridging of voltage dips		
Duration of dip	10 ms	10 ms
Repetition rate	1 s	1 s
Fault indication	LED	LED
Protection class	1	1
Isolation	Yes	Yes
Digital inputs		
Number of inputs	8	8
Rated voltage U_e	24 V DC	24 V DC
for "0" signal	≤ 5 V DC, limit value type 1	≤ 5 V DC, limit value type 1
for "1" signal	≥ 15 V DC	≥ 15 V DC
max. ripple	< 5 %	< 5 %
Rated current I_e		
with "1" signal	Normally 6 mA at 24 V DC	Normally 6 mA at 24 V DC

	PS 4-101-DD1	PS 4-111-DR1/ PS 4-111-DR5
Delay time		
for "0" to "1"	max. 55 μ s	max. 55 μ s
for "1" to "0"	max. 55 μ s	max. 55 μ s
Isolation	yes	yes
Isolation of inputs from each other	no	no
Status indication of inputs	LED	LED
Integrated power supply for inputs	–	short-circuit-proof
"High-speed counter" input	I0.0	I0.0
Number	1 up counter	1 up counter
Clock frequency	3 kHz	3 kHz
Pulse shape	Square wave	Square wave
Pulse duration	50 %	50 %
Edge duration	< 3 %	< 3 %
Setpoint potentiometer		
Number	2	2
Value range	0 to 255	0 to 255
Setting	with screw driver	with screw driver
Digital outputs		
Number of outputs	6	6
Contacts	Semiconductor	Relay (make contact)
Rated voltage U_e	24 V DC	–
permissible range	20.4 to 28.8 V DC	–
max. ripple	\leq 5 %	–
Protection against reverse polarity	yes	–
Isolation	yes	–
Isolation in groups	–	2 outputs isolated, 4 outputs in 2 groups of 2
Minimum contact voltage	–	> 12 V
Minimum contact current	–	> 100 mA
Minimum load	–	> 1.2 W
Rated current I_g on "1" signal	0.5 A at 24 V DC	–

Appendix

	PS 4-101-DD1	PS 4-111-DR1/ PS 4-111-DR5
Lamp load	4 W without series resistor	–
Utilization factor g	1	1
Relative duty factor	100 %	100 %
Outputs that can be switched in parallel		
number of outputs	max. 4	–
total max. current	2 A	–
total min. current	250 mA	–
Residual current on “0” signal	approx. 140 μ A	–
Closing time	–	max. 10 ms
Opening time	–	max. 15 ms
Lifespan (mechanical)	–	20 000 000 operations
Switching current (resistive load)		
2 A/230 V AC	–	300 000 operations
2 A/24 V DC	–	900 000 operations
Switching current (inductive load)		
1 A/230 V AC11	–	300 000 operations
1 A/24 V DC	–	100 000 operations
Short-circuit protection	yes, without automatic reset	no, external protection of relay contacts with 4 A fast fuse
Short-circuit tripping current	max. 1.2 A over 3 ms	–
Off-delay	Normally 50 μ s	–
Limitation of disconnection voltage with inductive loads	yes, –21 V (at $U_N = 24$ V DC)	–
Switch frequency		
with time constant $L/R \leq 72$ ms	4800 Ops/h	–
with time constant $L/R \leq 15$ ms	18000 Ops/h	–
Creepage distance and air clearance (relay)	–	8 mm between coil and contact
Status indication of outputs	LED	LED

General EMC specifications for automation equipment

Emission	EN 55 011/22 Klasse A		
Interference immunity			
ESD	EN 61 000-4-2	Contact discharge Air discharge	4 kV 8 kV
RFI	ENV 50 140	AM/PM	10 V/m
Burst	EN 61 000-4-4	Mains/digital I/O Analog I/O, fieldbus	2 kV 1 kV
Surge	ENV 50 142	Digital I/O, asymmetrical Mains DC, asymmetrical Mains DC, symmetrical Mains AC, asymmetrical Mains AC, symmetrical	0,5 kV 1 kV 0.5 kV 2 kV 1 kV
Immunity to line-conducted interference	ENV 50 141	AM	10 V

Index

A

Active slave	48
Asynchronous mode	54

B

Bus errors	69
Bus stations, maximum number	40

C

Cable ducts	36
Cables	34
Laying	35
Communication	40
Configuration	53, 73
Connecting the plug	13
Connecting the programming device	
PC	33
PRG3	32
Connection	
Overview	15
Connections	17
Control cabinet arrangement	18
Cycle errors	69
Cycle time	53

D

Device arrangement	19
Device earth	30
Diagnostics	77

E

EEPROM	60
EMC requirements	15
Event-driven functions	65
Expansion	
Central	42
Remote	45

F	
Function description	66
Function earth	30
G	
Generating the topology	76
H	
HALT	68
HALT NOT READY	68
High-speed counter	62
I	
Image register	72
Indication elements	77
Input image	72
Inputs	61
Installation	12
Interface	
PRG	32
Suconet K1	32
Interface, serial	61
Interface. PRG3	32
Interrupts, programmable	66
L	
LEDs	77, 78
Lightning protection	39
M	
MB35.0 marker byte	73
MB35.8 marker byte	
Setting	54
Transferring	55
Memory	60
Microprocessor	60
Mounting	
Fixing brackets	11
Top-hat rail	10
Mounting plate	
Earthing	31

O

Operating status HALT	68
Operating status RUN	70
Operating status STARTUP	69
Outputs	61

P

Power section	18
Power supply	
PS 4-101-DD1	20
PS 4-111-DR1/DR5	26
Power supply unit	62
Process image register	72
Program cycle	71
Program errors	69

R

RAM memory	60
Resources	48
Restart condition	69
Retentive behaviour	73
RUN	70

S

Screening	38
Setpoint potentiometers	62
Slave mode	48
Setting	53
Software	63
STARTUP	69
Startup modes	69
Status LEDs	77
Suconet K1	39
Suppressor circuits	38
Synchronous mode	53
System errors	68
System overview	
PS 4-101-DD1	7
PS 4-111-DR1/DR5	9
System software	63
System time	72

T

Top-hat rail
 Earthing 30

U

User program
 Transferring 55
User software 65

V

Ventilation 18
Version number 63