

**Part Number: CM1535-5 - Old Part Number: CM15-T5**  
**Tip Over Switch - Metal Mercury Contact - Normally Closed**  
**Product Data Sheet**

**PICTURE** **DIMENSIONS**

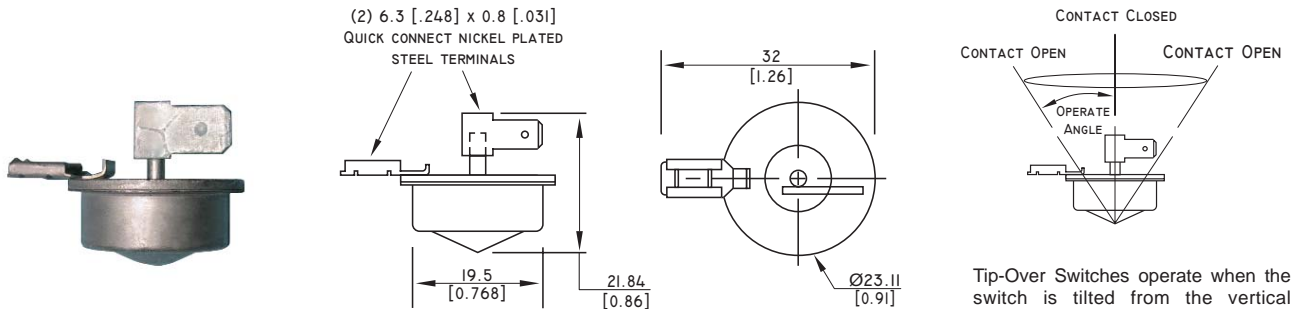

 **File Number E106699**

Drawings not to scale  
 All dimensions in mm [inches] nominal

Tip-Over Switches operate when the switch is tilted from the vertical position. The angle through which the switch has to move before operating is called the operating angle. These switches are omni-directional.

**SPECIFICATION**

Contact Form / Style		Normally Closed
Switching Voltage	Max.	120 VAC
Switching Current	Max.	12.5 A at 120 VAC
Switching Capacity	Max.	1500 VA.
Contact Resistance	Max.	5 Ohms
Operating Angle	Max.	35° ±10 Deg°
Operating Temperature Range		-37°C +100°C Deg°
Storage Temperature Range		-40°C +125°C Deg°
Case Material		Steel Nickel Plated
Features		Heavy Duty Switching

**APPLICATIONS**

- Safety - Portable Heater
- Security
- Position Detector
- Level Detector

**OPTIONS**

- Termination / Lead Wire
- Plating
- Tip-Over Angle
- Encapsulation
- If you do not see what you need, just ask, as there is a strong possibility we can do it !

**NOTE**

- When cutting, bending or soldering switch electrodes it is important that the glass to metal seal is not damaged. The cutting or bending point should be no closer than 3mm to the glass to metal seal and the electrode should be supported between the cutting or bending point and the glass to metal seal.

**Did you know we also sell?**



Rev. No.	Revision Note	Date	Signature
2	Datasheet Redesign	14-12-06	LG



As part of the company policy of continued product improvement, specifications may change without notice. Our sales office will be pleased to help you with the latest information on this product range and the details of our full design and manufacturing service. All products are supplied to our standard conditions of sale unless otherwise agreed in writing.

**Phone: (1) 973 777 6900** **www.comus-intl.com** **Fax : (1) 973 777 8405**

Belgium: + 32 (0)12 390400 - France: + 33 (0) 1 43 96 86 10 - Assemtech, UK: +44 (0) 1255 862236  
 ©2006 Copyright Comus International ,454 Alwood Road, Clifton NJ 07012, USA.