

# Rexroth IndraDrive and Rexroth IndraDyn – evolution in drive technology

Complete, intelligent and safe





Bosch Rexroth AG dominates in all relevant drive, control and motion technologies worldwide. We offer that vitally important added value in electric drive and control systems – regardless of where you are located and what you want to automate!



# Contents

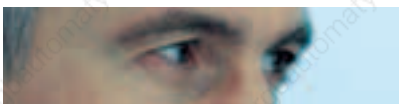
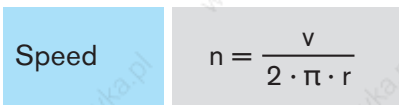
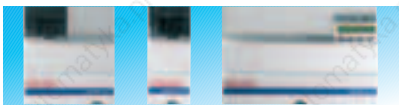

Drive expertise	4
<b>01</b>	
System overview	10
<b>02</b>	
Selection guide	12
<b>03</b>	
Power units	14
<b>04</b>	
Control units	28
<b>05</b>	
Firmware	42
<b>06</b>	
Motion Logic	44
<b>07</b>	
Safety technology	46
<b>08</b>	
Engineering and operation	50
<b>09</b>	
Motors and gearboxes	54
<b>10</b>	
Auxiliary components	76
<b>11</b>	
Glossary	94
<b>12</b>	
Formulas	96
<b>13</b>	
Additional information	98
<b>14</b>	

Speed

$$n = \frac{v}{2 \cdot \pi \cdot r}$$

# Our motivation is our drive

**For decades, Rexroth drives have been setting the standard in key areas of electric drive technology.**

Our motivation is partly derived from our desire to continuously demonstrate our technological lead in developing high-tech concepts.

Naturally, the other aspect which drives us is our ability to keep offering our customers the latest products and concepts to safeguard their future.

Rexroth has repeatedly taken its own trendsetting course. One example of this is the first industrial-grade, maintenance-free servo motor which presented the automotive industry with enormous savings on transfer machines. Other milestones include the first main spindle drive with positioning capability and decentralized automation designs with intelligent digital drives for modular machine concepts.

Linear motor technology is another ultra-modern and innovative field where Rexroth is a leader and can demonstrate more experience than any other company in the world.

Currently, one issue of vital importance is drive-integrated safety technology.

Rexroth has proven time and again that, in the long run, innovation and market success go hand in hand. Over one million Rexroth drives are in use around the world in a wide and diverse range of applications.

Rexroth IndraDrive, the latest generation of drives, and Rexroth IndraDyn, the complete range of motors, are the result of Rexroth's dedication to innovation in drive technology.

With their fully-integrated platform, innovative safety technology

and intelligent functions, Rexroth IndraDrive and IndraDyn are predestined for both intelligent single-axis and complex multiple-axis applications. This innovation in drive technology will set market trends again – to benefit all users.

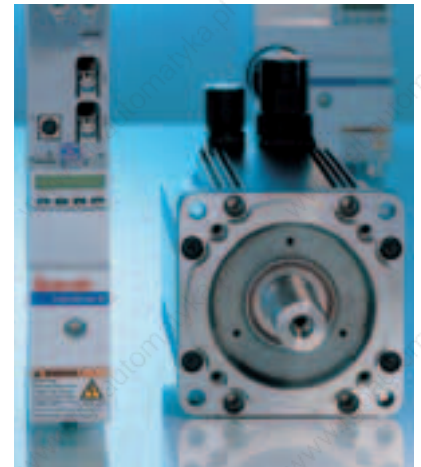

# Integrated innovation

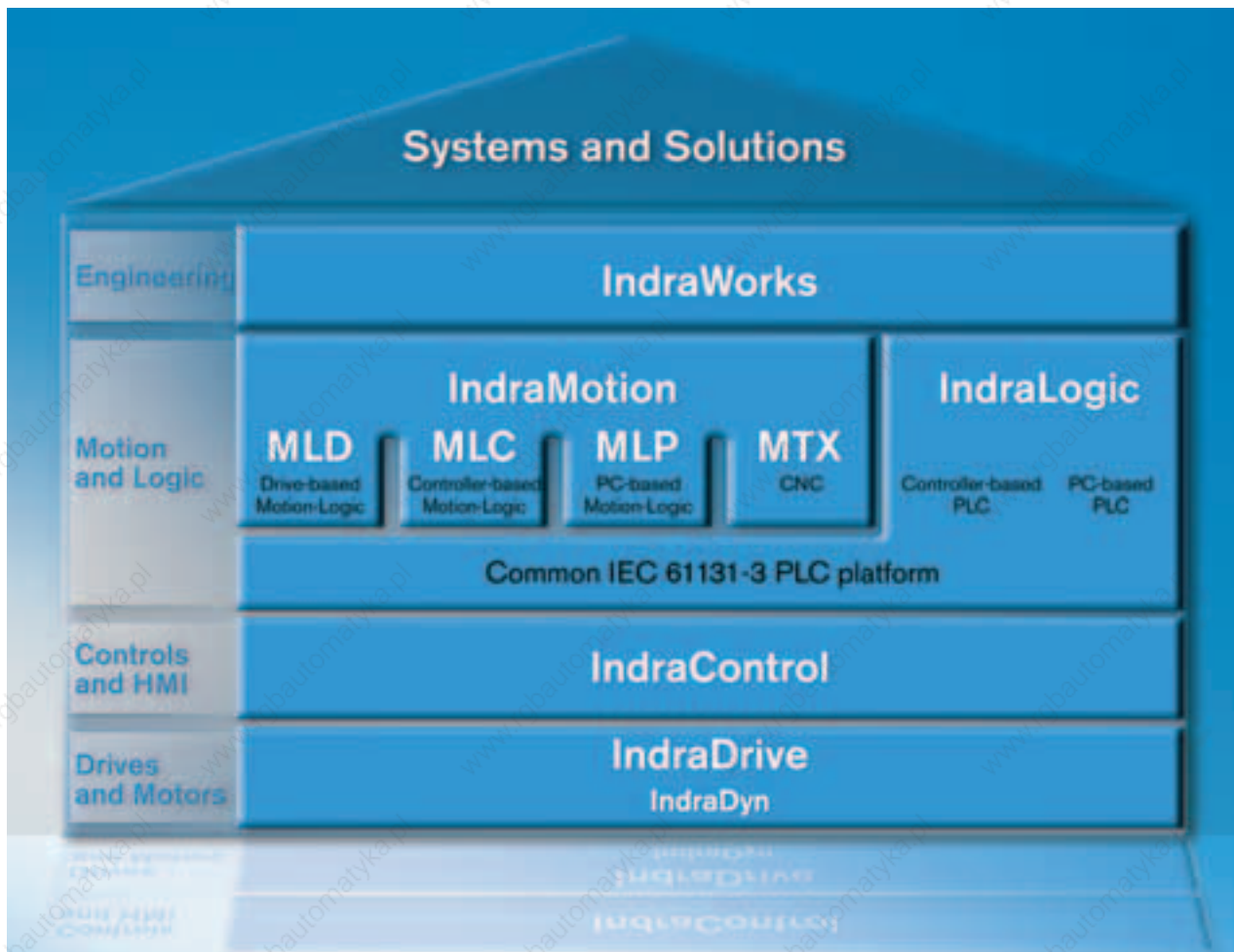

Rexroth's unique modular system combines all the elements required for successful automation concepts. From drive and control systems to the high-performance software framework for standardized engineering and user-friendly operation. This innovation gives you all the privileges associated with modern automation technology – integration, intelligence and investment for the future.

## **IndraDrive and IndraDyn**

The intelligent drive solution and comprehensive range of motors for maximum dynamics

## **IndraControl**

The standardized control and visualization hardware platform for increased transparency in production

## **IndraLogic**

The IEC-compliant PLC solution for intelligent automation

## **IndraMotion**

The scalable system software platform for high-performance motion control applications

## **IndraWorks**

The integrated engineering software package for project planning, programming, visualization and diagnostics

# Rexroth IndraDrive and Rexroth IndraDyn cause a stir in the drive market

## This new design is redefining standards in drive technology.

Complete in terms of hardware and software, safe in terms of application and intelligent in terms of functionality:

With IndraDrive and IndraDyn you will benefit from the economic, intelligent and future-assured approach to your automation tasks – regardless of your industry!

It is the combination of three features which gives IndraDrive its unique and pioneering edge:

- Inclusive platform
- Integrated intelligence
- Innovative safety concept

When it comes to practical applications, IndraDrive offers many advantages such as:

- Safety on Board conforming to EN 954-1, Category 3, for safe stop and safe motion
- Wide power range from 1 kW to 120 kW

- Internationally standardized interfaces
- Integrated Motion Logic, with IEC 61131-3 compliant PLC
- Highest performance and precision
- Scalable power and functionality
- Direct mains connection
- Energy-saving power recovery

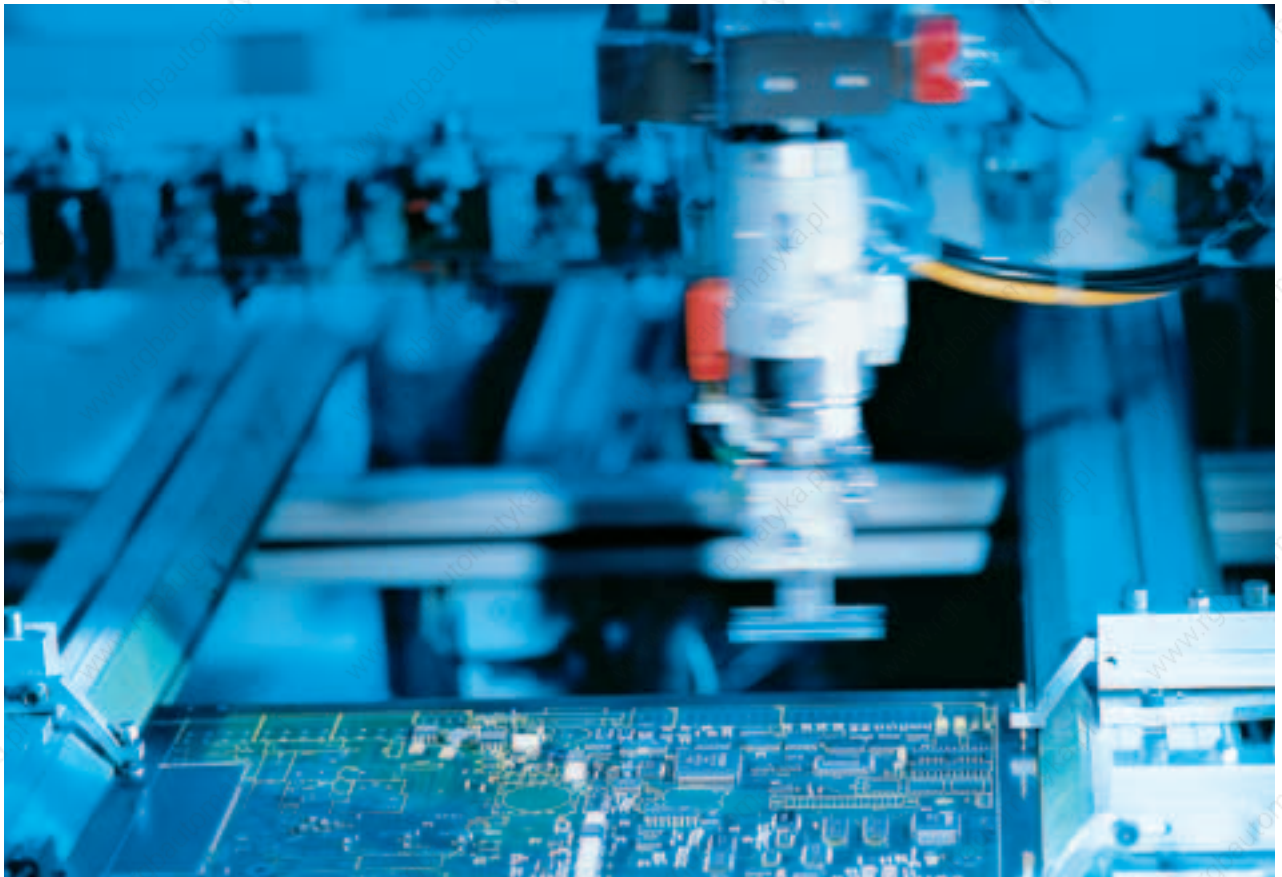



## IndraDrive has the power to convince

No matter what demands you make on your drive – IndraDrive offers an impressive array of key benefits:

- Integrated hardware platform
- Scalable functionality
- Unique safety concept

# Your benefits

### Safety on Board

The certified safety technology, conforming to EN 954-1, Category 3, provides for operator protection – even when axes are in motion. Unlike conventional safety concepts, this technology consists of power protection devices in the mains and motor supply lines and saves on additional monitors and sensors.

### Integrated Motion Logic with IEC 61131-3 compliant PLC

Motion Logic with IEC 61131-3 compliant PLC can be integrated as an optional feature that consistently applies open standards. This makes it easier to bring in customer know-how and saves on higher-level control systems and personnel training courses.

### Integrated technology functions

The technology functions can be configured on the basis of Motion Logic to perform a wide and diverse range of process-oriented tasks. This does not require any programming knowledge whatsoever on the user's part.

### Open interfaces

Internationally recognized interfaces are available for communicating with higher-level machine control systems: SERCOS, PROFIBUS DP, PROFINET IO, CANopen, DeviceNet, analog and parallel.

### A single software for all tasks

The engineering software toolkit, IndraWorks, carries you through all the steps involved in project planning, programming, parameterization, operation and diagnostics.

### A unique platform

In the interests of meeting your individual requirements, we have developed two versions of IndraDrive:

- IndraDrive C - Compact converters
- IndraDrive M - Modular inverters

Particularly economic drive solutions can be derived from the common control units and the combination of different versions.

### A complete range of motors

The newly developed generation of IndraDyn motors meets all the requirements of modern factory automation through its diversity of design and unique performance:

- Synchronous and asynchronous servo motors which are more compact and more powerful
- Servo motors designed for potentially explosive areas – conforming to ATEX and UL/CSA
- Synchronous and asynchronous motors for high-speed applications such as motor spindles

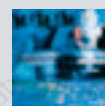

Automation

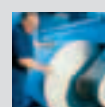

Printing and converting machines

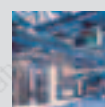

Conveying and storage systems



Glass processing machines



Handling and assembly systems

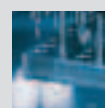

Woodworking machines



Plastics processing machines

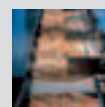

Food processing and packaging machines

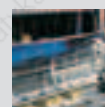

Textile machines



Metal forming

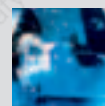

Machine tools



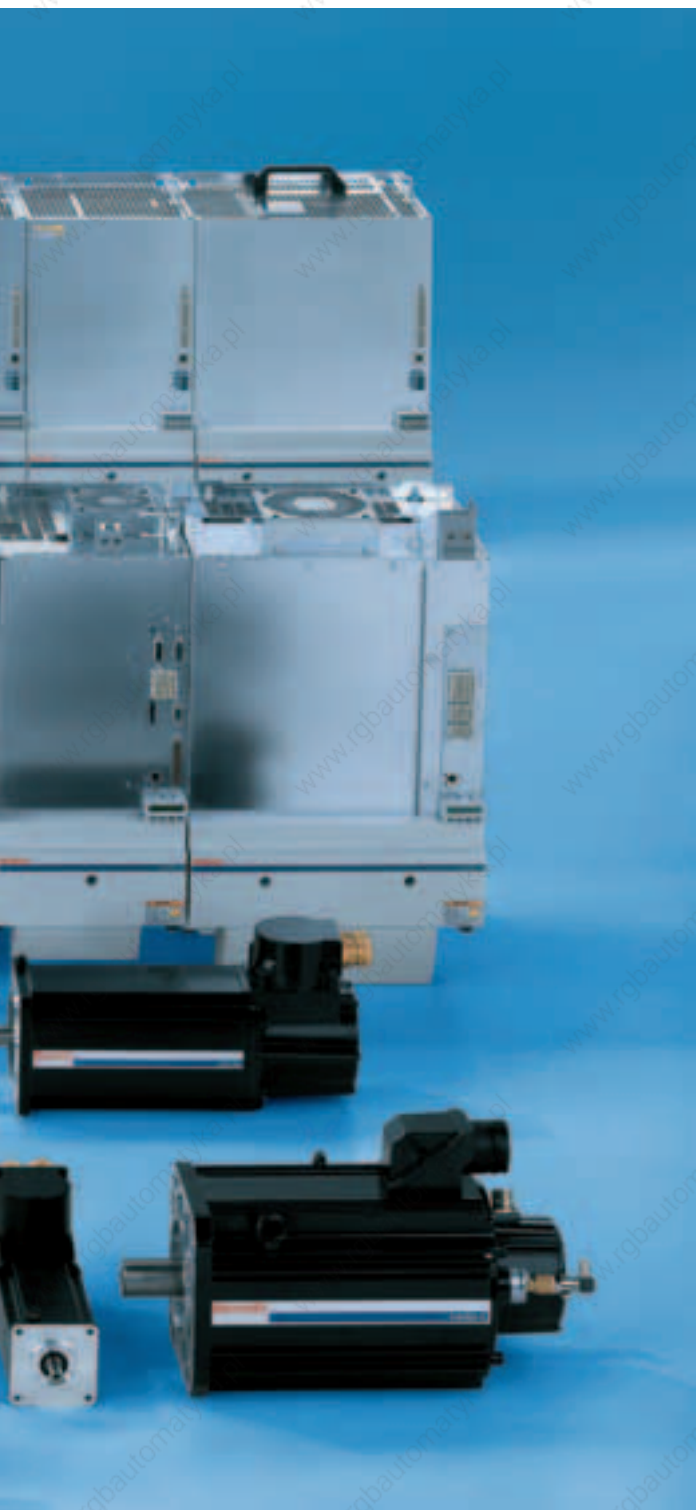

IndraDrive stands for innovation all along the line. Therefore, choosing the new drive generation from Rexroth means that your every wish will be fulfilled.

Main features of the IndraDrive:

- Compact converters and modular inverters on one platform
- Integrated Motion Logic with IEC-compliant PLC
- Drive-integrated safety technology
- Intelligent technology functions
- Integrated engineering framework for project planning, programming, operation and diagnostics
- Complete range of synchronous and asynchronous motors

# Leaving nothing to be desired: Rexroth IndraDrive – the complete system

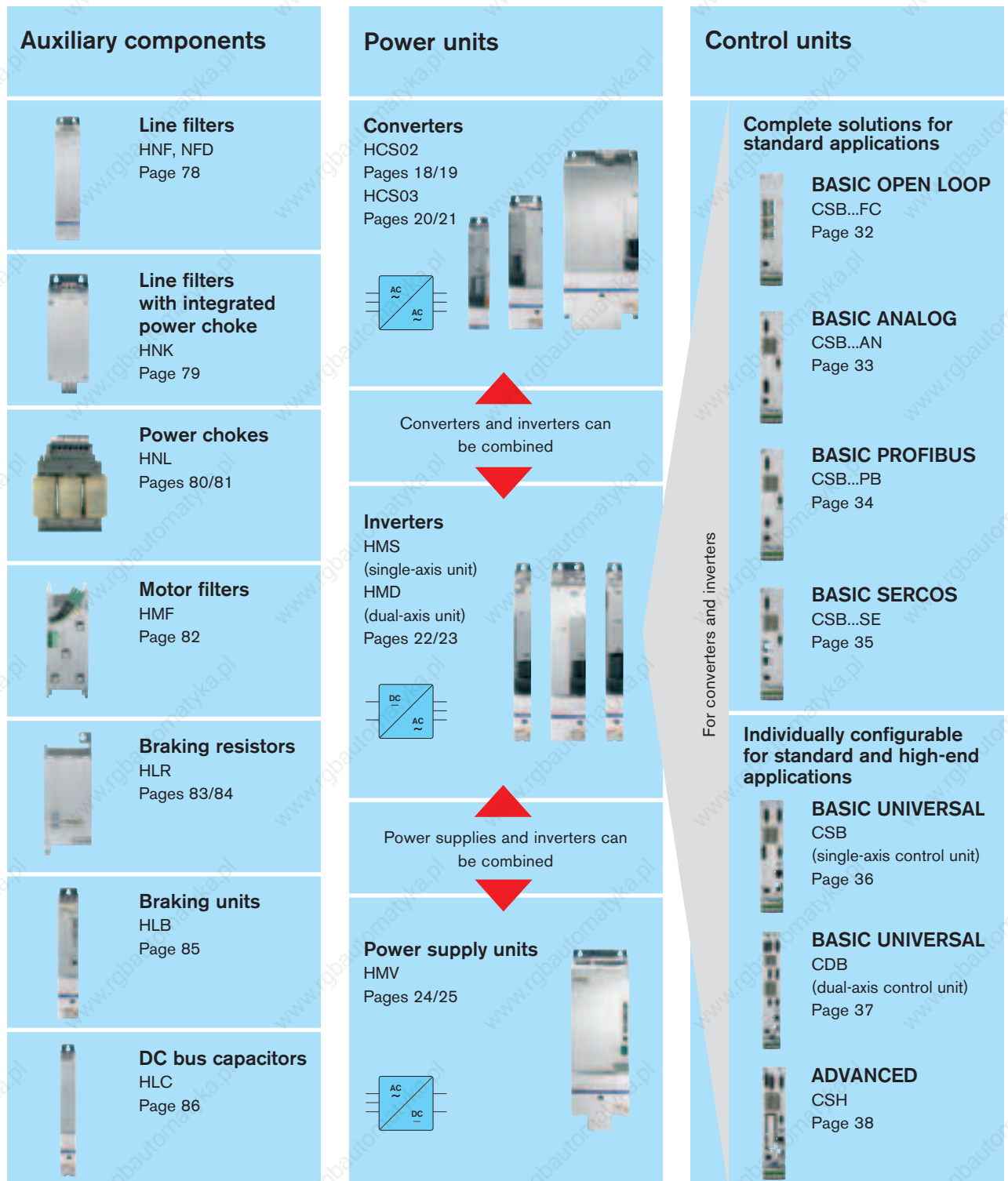

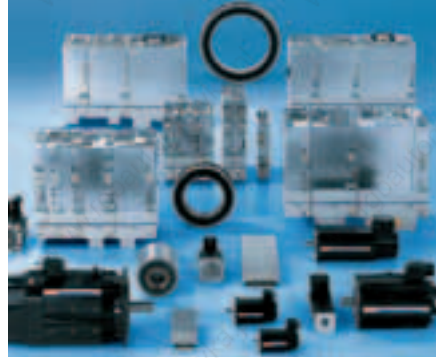

## Seamlessly coordinated

- | Integrated system
- | Scalable power
- | Flexible function blocks
- | Open communications standards
- | Future-proof

# Your benefits

## Firmware

### Basic package

**OPEN LOOP /  
CLOSED LOOP**

The basic package contains all the functions for standard applications.

### Extension packages

**SERVO**

Frictional torque compensation and compensation for backlash on reversal, axis and transducer error correction, touch probe, etc.

**SYNCHRONIZATION**

Electronic gears, electronic cam plate, etc.

**MAIN SPINDLE**

Spindle positioning, gear change, etc.

**IndraMotion MLD**

Motion Logic conforming to IEC 61131-3

**Technology packages  
based on IndraMotion MLD**

Productivity Agent (predictive maintenance), function blocks, demand processing, special cam groups, extended drive function, PLCopen library, etc.

Pages 42/43

## Engineering and operation



**Standard  
operating panel**  
Page 39



**Comfort  
operating panel**  
Page 39



**Additional  
operating panels  
VCP**  
Page 39



**MultiMediaCard**  
PFM  
Page 39



**IndraWorks**  
Engineering software  
framework for start-  
up, programming, etc.  
Pages 50/51

## Cables



**Power cables**  
RKL  
Pages 92/93



**Feedback cables**  
RKG  
Pages 92/93



**Fiber optic  
cables, bus  
connectors, etc.**

## Motors and gearboxes



**Synchronous  
servo motors**  
IndraDyn S  
MSK, MKE  
Pages 56–59



**Asynchronous  
servo motors**  
IndraDyn A  
MAD, MAF  
Pages 60–63



**Synchronous  
linear motors**  
IndraDyn L  
MLP/MLS  
Pages 64/65



**Synchronous  
high-speed  
motors**  
IndraDyn H  
MSS/MRS  
Pages 66/67



**Synchronous  
torque motors**  
IndraDyn T  
MST/MRT  
Pages 68/69



**Gearboxes  
for servo motors**  
GTE, GTM  
Pages 70–73



**Standard and  
geared motors**  
Page 74

## Five steps to your drive solution



Step	Example	Help
<b>1 Determine your drive requirements</b> <ul style="list-style-type: none"> <li>• Torque, speed, power, ...</li> <li>• Performance (control quality ...)</li> <li>• Interfaces, functions</li> <li>• Single-axis or multi-axis drive</li> </ul>	<b>I Servo drive for a handling axis</b> <ul style="list-style-type: none"> <li>• RMS torque 4.5 Nm</li> <li>• Maximum torque 8 Nm</li> <li>• Speed 2,500 rpm</li> <li>• PROFIBUS interface</li> <li>• Simple servo functionality</li> </ul>	<b>Drive sizing program</b> IndraSize Pages 52/53
<b>2 Select the power unit/motor combination</b>	<b>I IndraDrive C with IndraDyn S</b> HCS02.1E-W0028-A-03-NNNN MSK050C-0300-NN-S1-UG0-NNNN <ul style="list-style-type: none"> <li>• Standstill torque 5 Nm</li> <li>• Maximum torque 9 Nm</li> <li>• Maximum speed 3,000 rpm</li> </ul>	<b>Power units</b> Pages 14–27  <b>Motors</b> Pages 54–75
<b>3 Identify the control unit performance and interfaces</b> <ul style="list-style-type: none"> <li>• Higher-level control system</li> <li>• Feedback</li> <li>• Inputs and outputs</li> <li>• Safety technology</li> </ul>	<b>I BASIC PROFIBUS</b> CSB01.1N-PB-ENS-NNN-NN-S-NN-FW <ul style="list-style-type: none"> <li>• Standard performance</li> <li>• PROFIBUS</li> <li>• IndraDyn standard feedback</li> <li>• Standard operator panel</li> <li>• No additional options</li> </ul>	<b>Control units</b> Pages 28–41
<b>4 Define the firmware function</b> <ul style="list-style-type: none"> <li>• Basic OPEN LOOP or CLOSED LOOP package</li> <li>• Extension packages</li> <li>• Motion Logic</li> <li>• Technology functions</li> </ul>	<b>I Basic CLOSED LOOP package</b> FWA-INDRV*-MPB-03VRS-D5-1-NNN-NN <ul style="list-style-type: none"> <li>• No extension packages</li> </ul>	<b>Firmware</b> Pages 42/43
<b>5 Select the accessories</b> <ul style="list-style-type: none"> <li>• Line filters and power chokes</li> <li>• Braking resistors, braking units</li> <li>• DC bus capacitors</li> <li>• Cables</li> <li>• Software</li> </ul>	<b>I Line filter</b> NFD03.1-480-016 <b>I Power cable</b> RKL4302/005,0 <b>I Feedback cable</b> RKG4200/005,0 <b>I Basic accessories</b> HAS01.1-065-NNN-CN <b>I Shielded connection plate</b> HAS02.1-002-NNN-NN <b>I Software</b> SWA-IWORKS-D**-xxVRS-D0-CD650-COPY	<b>Auxiliary components</b> Pages 76–93  <b>Engineering software toolkit</b> IndraWorks Pages 50/51

# Rexroth IndraDrive – power units





## Customized for the desired number of axes and performance level.

- Wide power range – for all applications
- Converters and inverters can be combined – ideal for small axis groups
- Power supplies and inverters can be combined – ideal for large axis groups

# Your benefits

### IndraDrive C – compact converters

- Power range from 1.5 kW to 110 kW with maximum current from 11 A to 350 A
- High overload capacity
- Compact design for single-axis applications
- Can be connected to inverters for cost-effective solutions
- Direct mains connection from 200 to 500 V

### IndraDrive M – modular inverters

- Single-axis inverter with maximum current from 20 A to 210 A
- Dual-axis inverter with maximum current from 12 A to 36 A
- Space-saving design for multi-axis applications
- Can be powered via power supply unit or converter
- Energy exchange via common DC bus
- Can be connected to converters for cost-effective solutions

### IndraDrive M – modular power supplies

- Power range from 18 kW to 120 kW
- Direct mains connection from 400 V to 480 V
- Energy-saving line regeneration
- Integrated mains contactor
- Integrated braking resistor

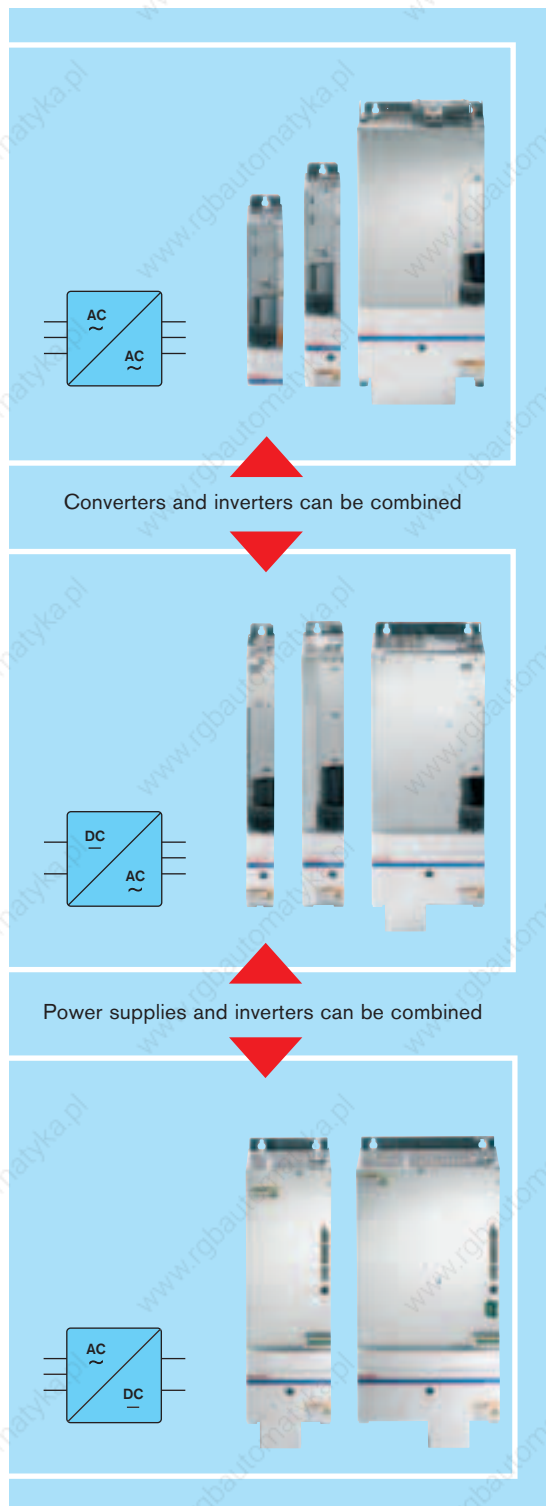

# IndraDrive – the clever combination of power units

## Single-axis solution with a converter

The IndraDrive C series of converters – HCS02 and HCS03 – integrate inverter and power supply in one unit. The compact construction contains additional mains connection components, making it particularly suitable for single-axis applications.

3 AC 200 ... 500 V



## Multi-axis solution with converters and inverters

A combination of IndraDrive C converters and modular IndraDrive M inverters is a particularly cost-effective solution for small axis groups.

3 AC 400 ... 500 V

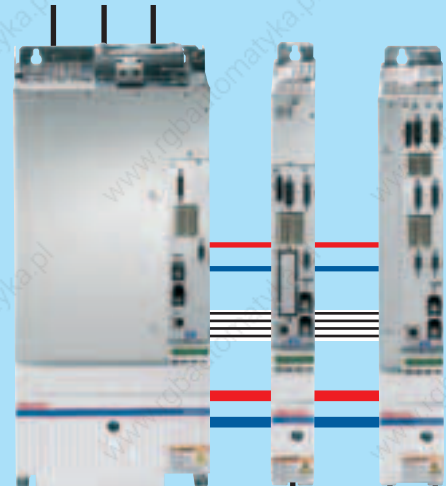

## Multi-axis solution with power supplies and inverters

Multi-axis applications are the domain of the modular system IndraDrive M. Power supplies provide the necessary DC bus voltage for the inverters. Compact single-axis or dual-axis inverters and power supplies with integrated mains connection components enable compact solutions for large axis groups.

Maximum energy efficiency can be achieved with power supplies that are capable of line regeneration. Besides the power recovery encountered in regenerative operation of the drives, another outstanding feature of these devices is the closed-loop DC bus.

3 AC 400 V ... 480 V

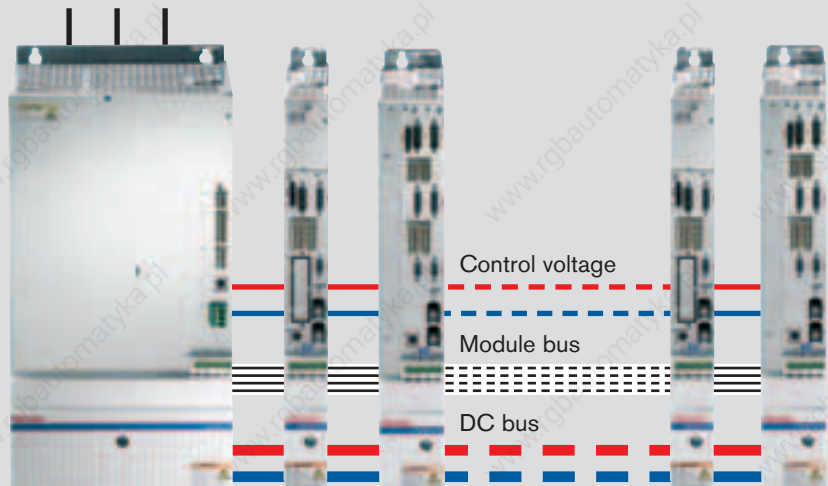

Power units	IndraDrive C			IndraDrive M		
	converter		converter	inverter	power supply units	power supply units
	HCS02	HCS03	HMS01/HMD01	w/o line regeneration HMV01.1E	w/ line regeneration HMV01.1R	
Mains voltage	V	1 AC 200 ... 250 V 3 AC 200 ... 500 V (±10 %)	3 AC 400 ... 500 V (+10 %/-15 %)	-	3 AC 400 ... 480 V (+10 %/-15 %)	
Supply frequency	Hz	48 ... 62		-	48 ... 62	
Power range	kW	1.5 ... 11	15 ... 110	1.5 ... 75	18 ... 120	18 ... 120
Overload capacity		2.5x	2x	1.5 ... 2.5x	1.5x	2.5x
Switching frequency $f_s$ <sup>1)</sup>	kHz	4/8/12/16			-	
Max. output frequency at $f_s = 4/8/12/16$ kHz	Hz	400/800/1,200/1,600			-	
Suitable for switch cabinet depth	mm	300	400	400		
Mains contactor		external		-	internal	
Brake chopper		internal	optional internal	-	internal	
Braking resistor		internal (optional external)	external	-	internal	
Combined converter/inverter option		yes	yes	yes	-	
Control voltage DC 24 V		external (optional internal)	internal or external	external		
Protection category		IP20				
Installation height	m	1,000 over NN, with derating to 4,000				
Ambient temperature	°C	0 ... +40, with derating to +55				
Relative air humidity	%	5 ... 95 (as per EN 61800-5-1), condensation not permitted				
Degree of contamination		2 (as per EN 61800-5-1)				
Cooling System		Air cooling				
CE mark		Complies with the low voltage directive 73/23/EEC and the EMC directive 89/336/EEC				
Certification		UL, cUL				
EMC		as per EN 61800-3				

All data for nominal rating at 3 AC 400 V mains voltage and 4 kHz switching frequency

<sup>1)</sup>HMD01 to 8 kHz only

# IndraDrive C – compact converters HCS02

		Converters			
Models with integrated control voltage supply no additional options		HCS02.1E-W0012 -A-03-NNNV -A-03-NNNN	HCS02.1E-W0028 -A-03-NNNV -A-03-NNNN	HCS02.1E-W0054 -A-03-NNNV -A-03-NNNN	HCS02.1E-W0070 -A-03-NNNV -A-03-NNNN
<b>Performance data</b>					
Continuous current	A	4.5	11.3	20.6	28.3
Maximum current	A	11.5	28.3	54	70.8
Continuous output without/with choke	kW	2.1/2.1	5.1/5.1	7/10	9/14
Maximum output without/with choke	kW	5/5	8/10	12/16	14/19
Mains voltage	V	3 AC 200 ... 500, 1 AC 200 ... 250 ( $\pm 10\%$ )			
Continuous input mains current	A	6	13	19	30
Dependence of output on mains voltage		at $U_{LN} < 400$ V: 1 % power reduction per 4 V at $U_{LN} > 400$ V: 1 % power reduction per 5 V			
DC bus terminal <sup>1)</sup>		–	●	●	●
DC bus capacity	$\mu$ F	135	270	405	675
Output voltage	V	0 ... 335 (at DC bus voltage DC 475 V) 0 ... 400 (at DC bus voltage DC 570 V) 0 ... 530 (at DC bus voltage DC 750 V)			
<b>Braking resistance</b>					
Braking resistor		internal	internal	internal/external	internal/external
Maximum braking energy consumption	kWs	1	5	9	13
Continuous braking power	kW	0.05	0.15	0.35/3.8	0.5/5.5
Maximum braking power	kW	4	10	18	25
<b>Control voltage data</b>					
Control voltage, internal	V	DC 24 (not for supply of motor holding brake)			
Control voltage, external	V	DC 24 $\pm 20\%$ (DC 24 $\pm 5\%$ when supplying motor holding brake)			
Power consumption excluding control component and motor brake	W	12	14	23	23
<b>Mechanical data</b>					
Width W	mm	65	65	105	105
Height H	mm	290		352	
Depth D (incl. plug)	mm	265			
Mass	kg	2.9	3.8	6.7	6.8

All data apply to nominal rating at 3 AC 400 V mains voltage and 4 kHz switching frequency

<sup>1)</sup>For the connection of additional units, such as HMS, HCS, HLB, HLC

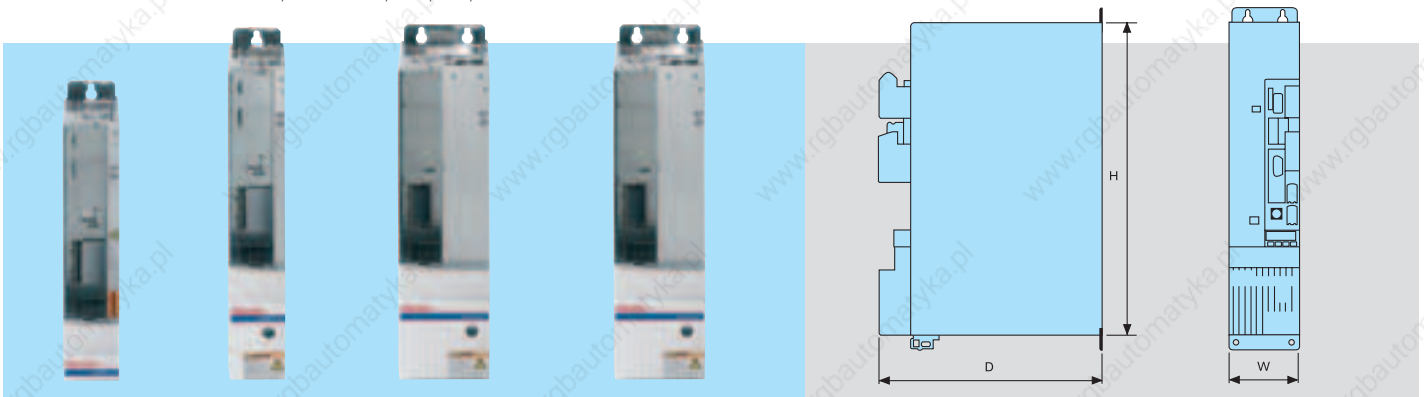

# HCS02

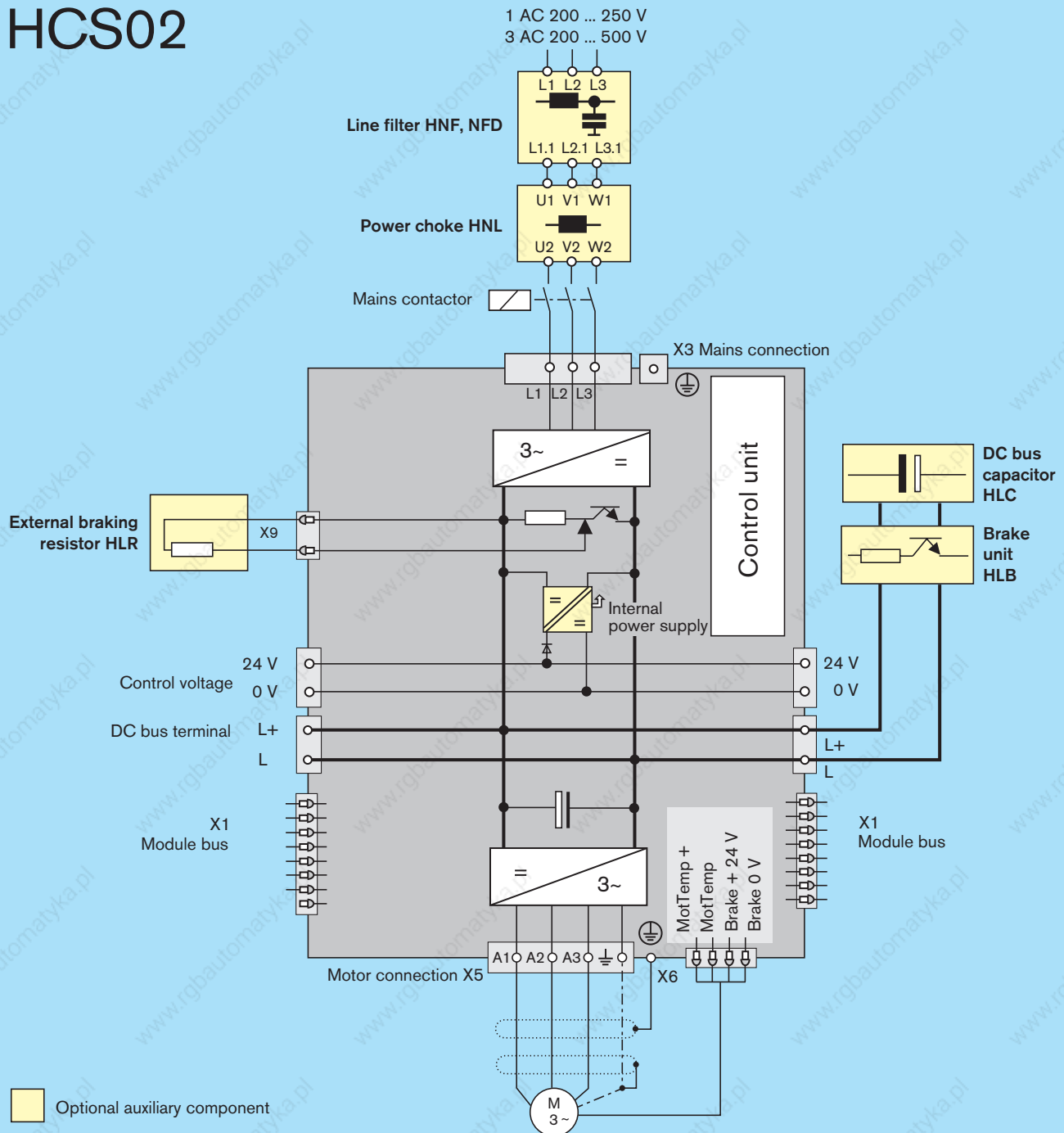

Connection X9 not required with HCS02.1E-W0012 and -W0028

No DC bus terminal with HCS02.1E-W0012

When line filters HNF and NFD are used, the maximum input voltage is 3 AC 480 V.

# IndraDrive C – compact converters HCS03

Models	Converters				
	HCS03.1E-W0070	HCS03.1E-W0100	HCS03.1E-W0150	HCS03.1E-W0210	HCS03.1E-W0350
	with integrated control voltage supply	-A-05-NNNV	-A-05-NNNV	-A-05-NNNV	-A-05-NNNV
with integrated brake chopper and integrated control voltage supply	-A-05-NNBV	-A-05-NNBV	-A-05-NNBV	-A-05-NNBV	-A-05-NNBV

Performance data						
Continuous current	A	45	73	95	145	210
Maximum current	A	70	100	150	210	350
Continuous output	kW	25	42	56	85	125
Maximum output	kW	40	59	89	124	180
Mains voltage	V	3 AC 400 ... 500 (+10 %/–15 %)				
Continuous input mains current	A	50	80	106	146	220
Dependence of output on mains voltage		at $U_{LN} < 400$ V: 1 % power reduction per 4 V decrease in voltage				
DC bus terminal <sup>1)</sup>		●	●	●	●	●
DC bus capacity	μF	940	1,440	1,880	4,700	
Output voltage	V	0 ... 335 (at DC bus voltage DC 475 V) 0 ... 400 (at DC bus voltage DC 570 V) 0 ... 530 (at DC bus voltage DC 750 V)				

Brake chopper						
Continuous brake power	kW	13.2	18.9	25.2	42.6	55
Maximum brake power	kW	42	63	97	137	180

Control voltage data						
Control voltage, internal	V	DC 24 (not for supply of motor holding brake)				
Control voltage, external	V	DC 24 ± 20 % (DC 24 ± 5 % when supplying motor holding brake)				
Power consumption excluding control unit and motor brake	W	22.5	25	25	30	available soon

Mechanical data						
Width W	mm	125	225	225	350	available soon
Height H	mm	440	440	440	440	440
Depth D (incl. plug)	mm	315	315	315	315	315
Mass	kg	13	20	20	38	available soon

All data apply to nominal rating at 3 AC 400 V mains voltage and 4 kHz switching frequency

<sup>1)</sup>For the connection of additional units, such as HMS, HCS

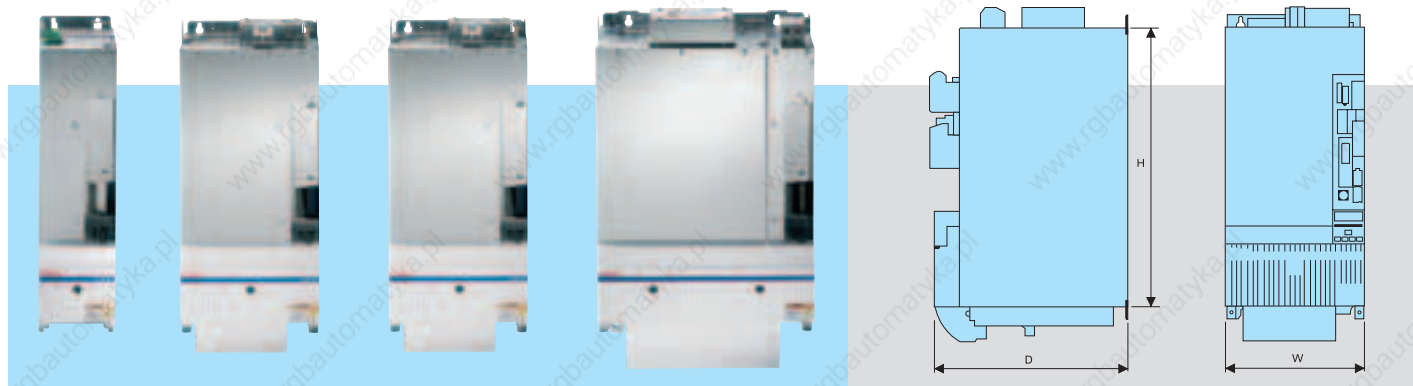

# HCS03

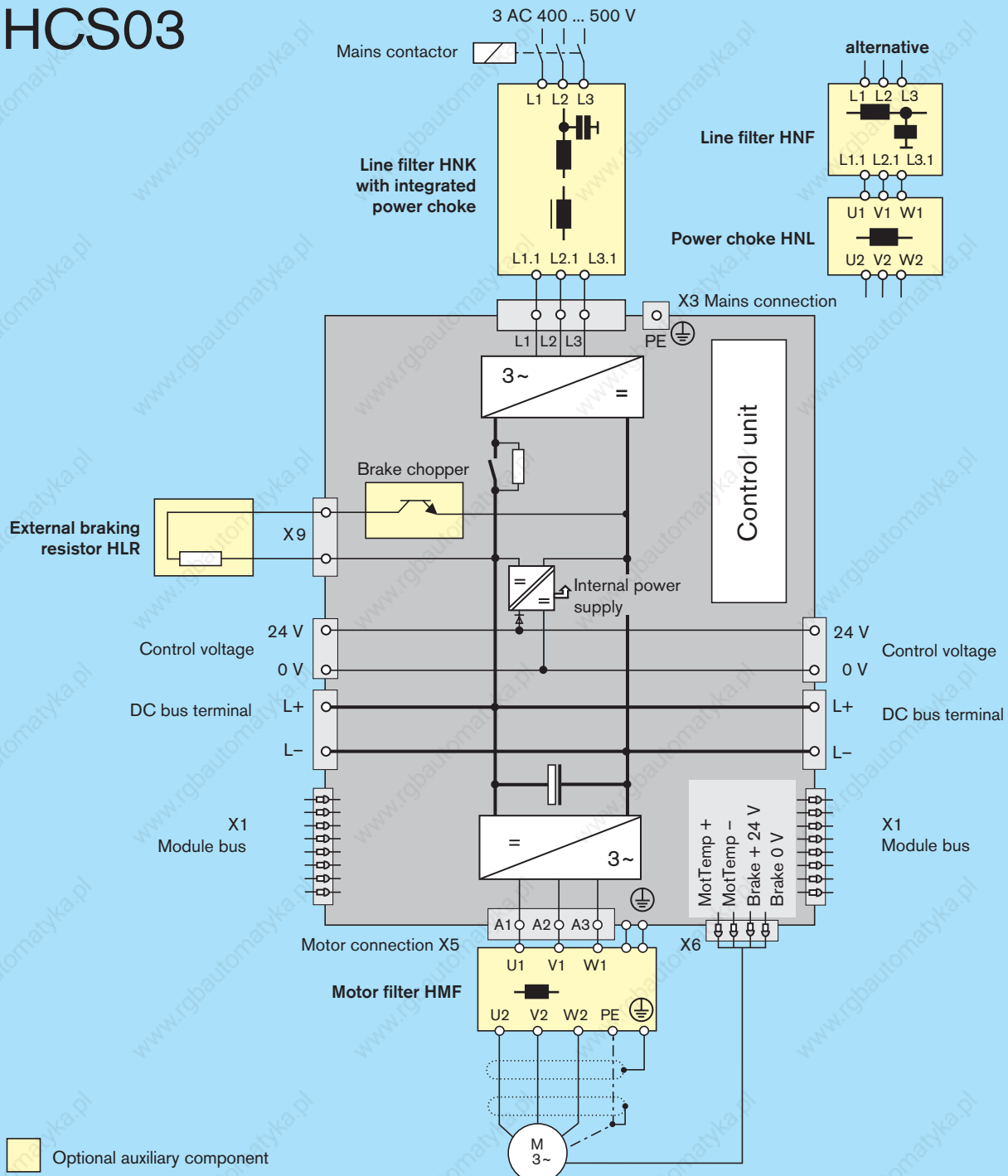

 Optional auxiliary component

When HNF line filters are used, the maximum input voltage is 3 AC 480 V.

# IndraDrive M – modular inverters HMS01 and HMD01

		Single-axis inverters						Dual-axis inverters		
Models		HMS01.1N- W0020-A-07	HMS01.1N- W0036-A-07	HMS01.1N- W0054-A-07	HMS01.1N- W0070-A-07	HMS01.1N- W0150-A-07	HMS01.1N- W0210-A-07	HMD01.1N- W0012-A-07	HMD01.1N- W0020-A-07	HMD01.1N- W0036-A-07
no further options		-NNNN	-NNNN	-NNNN	-NNNN	-NNNN	-NNNN	-NNNN	-NNNN	-NNNN
<b>Performance data</b>										
Continuous current	A	12.1	21.3	35	42.4	100	150	7	10	20
Maximum current	A	20	36	54	70	150	210	12	20	36
Output voltage	V	0 ... 335 (at DC bus voltage DC 475 V) 0 ... 400 (at DC bus voltage DC 570 V) 0 ... 530 (at DC bus voltage DC 750 V)								
<b>Control voltage data</b>										
Control voltage, external	V	DC 24 ± 20 % (DC 24 ± 5 % when supplying motor holding brake)								
Power consumption	W	10.1	15.1	9.6	16.1	22.8	72.0	16.6	16.6	10.8
<b>Mechanical data</b>										
Width W	mm	50	50	75	100	150	200	50	50	75
Height H	mm	440								
Depth T (incl. plug)	mm	309								
Mass	kg	5.3	5.3	6.7	7.9	12.7	18.4	5.5	5.7	7.5

All data apply to nominal rating at 3 AC 400 V mains voltage and 4 kHz switching frequency



# HMS01

# HMD01

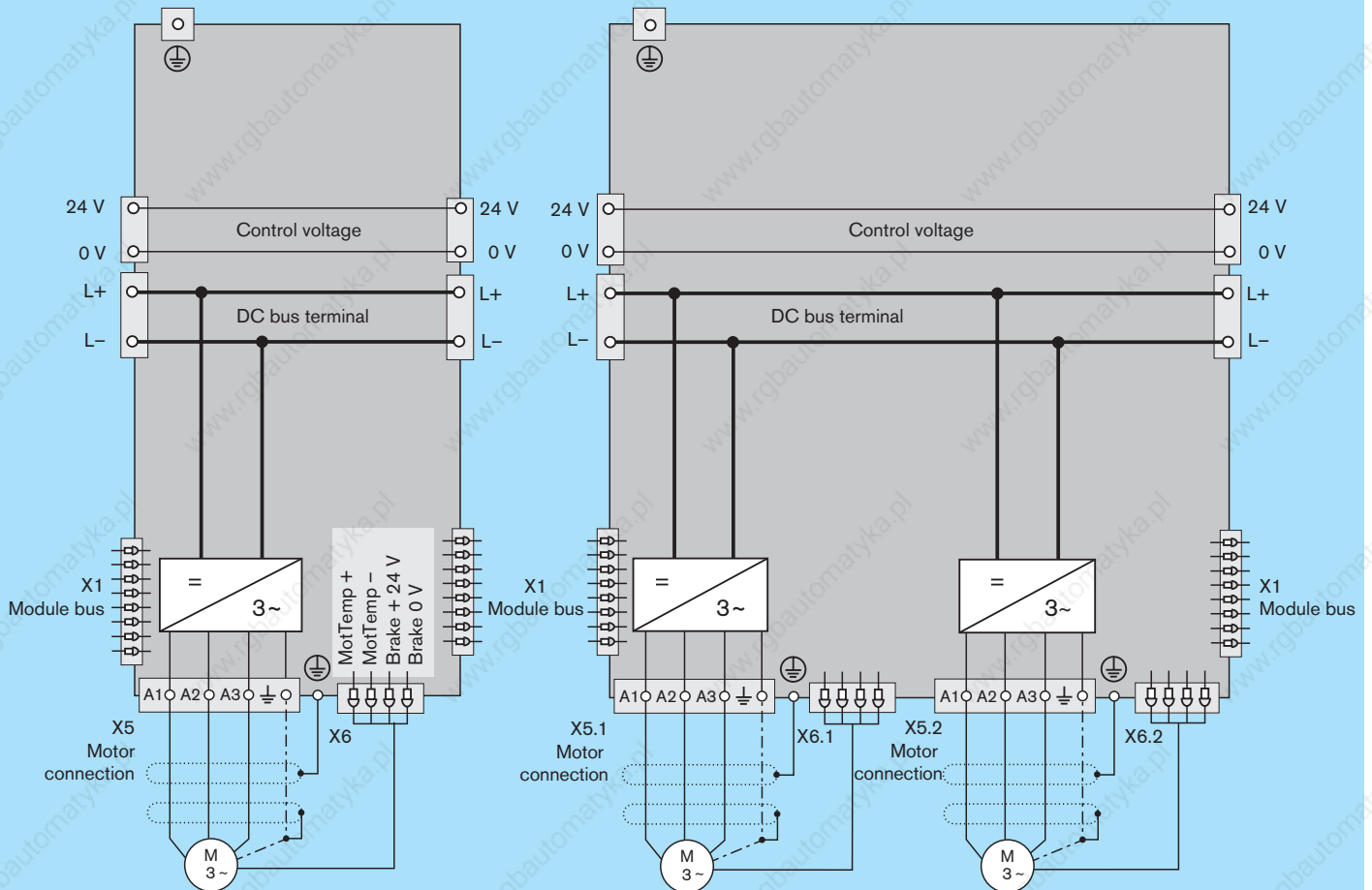

# IndraDrive M – modular power supplies HMV01

Model	Supply device without line regeneration			Supply device with line regeneration			
	HMV01.1E- W0030-A-07	HMV01.1E- W0075-A-07	HMV01.1E- W0120-A-07	HMV01.1R- W0018-A-07	HMV01.1R- W0045-A-07	HMV01.1R- W0065-A-07	HMV01.1R- W0120-A-07
no additional options	-NNNN	-NNNN	-NNNN	-NNNN	-NNNN	-NNNN	-NNNN

Performance data								
Continuous output without/with choke	kW	18/30	45/75	72/120	-/18	-/45	-/65	-/120
Maximum output	kW	45	112	180	45	112	162	available soon
Mains voltage	V	3 AC 400 ... 480 (+10/-15 %)						
Continuous input mains current	A	50	125	200	30	70	100	available soon
Dependence of output on mains		at $U_{LN} < 400$ V: 1 % power reduction per 4 V						
		at $U_{LN} > 400$ V: 1 % power gain per 4 V			at $U_{LN} > 400$ V: no power gain			
DC bus capacity	$\mu$ F	1,410	3,760	5,640	705	1,880	2,820	available soon
DC bus voltage range	V	DC 435 ... 710			DC 750 (regulated)			

Braking resistance								
Braking resistor		internal						
Maximum braking energy consumption	kWs	100	250	500	80	100	150	available soon
Continuous braking power	kW	1.5	2.0	2.5	0.4	0.4	0.4	available soon
Maximum braking power	kW	36	90	130	36	90	130	available soon

Control voltage data								
Control voltage, external	V	DC $24 \pm 20$ %						
		(DC $24 \pm 5$ % when supplying motor holding brake)						
Power consumption	W	25	35	50	32	38	98	available soon

Mechanical data								
Width W	mm	150	250	350	175	250	350	available soon
Height H	mm	440						
Depth T (incl. plug)	mm	309						
Mass	kg	13.5	22	32	13.5	20	31	available soon

In the case of the HMV01.1R the continuous output and maximum output data also apply to the regenerative feedback mode.

All data apply to nominal rating at 3 AC 400 V mains voltage

Connection option for auxiliary components, such as HLB, HLC, etc.

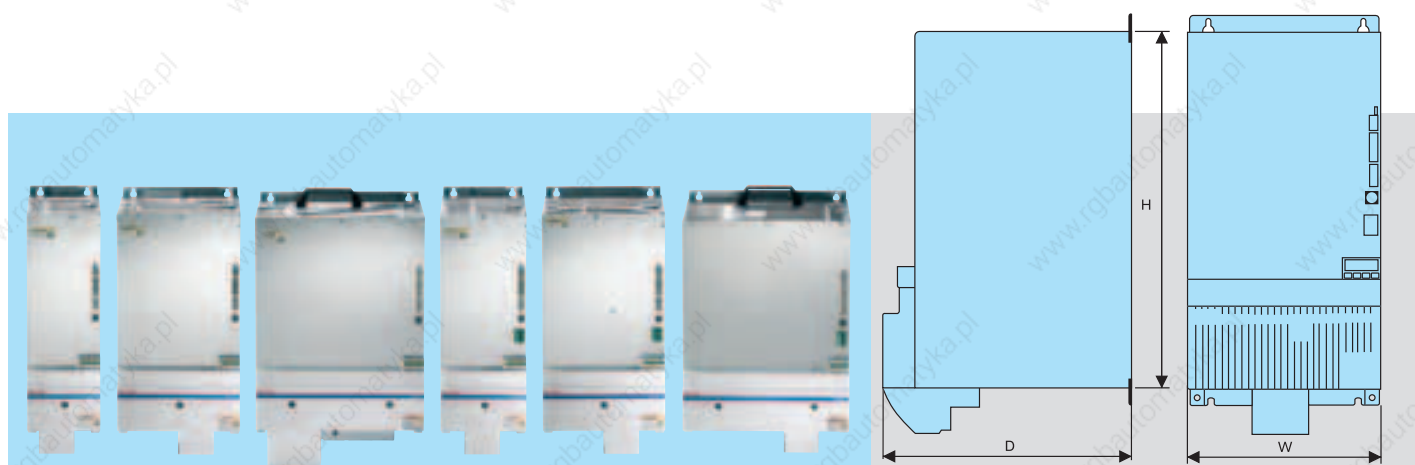

# HMV01

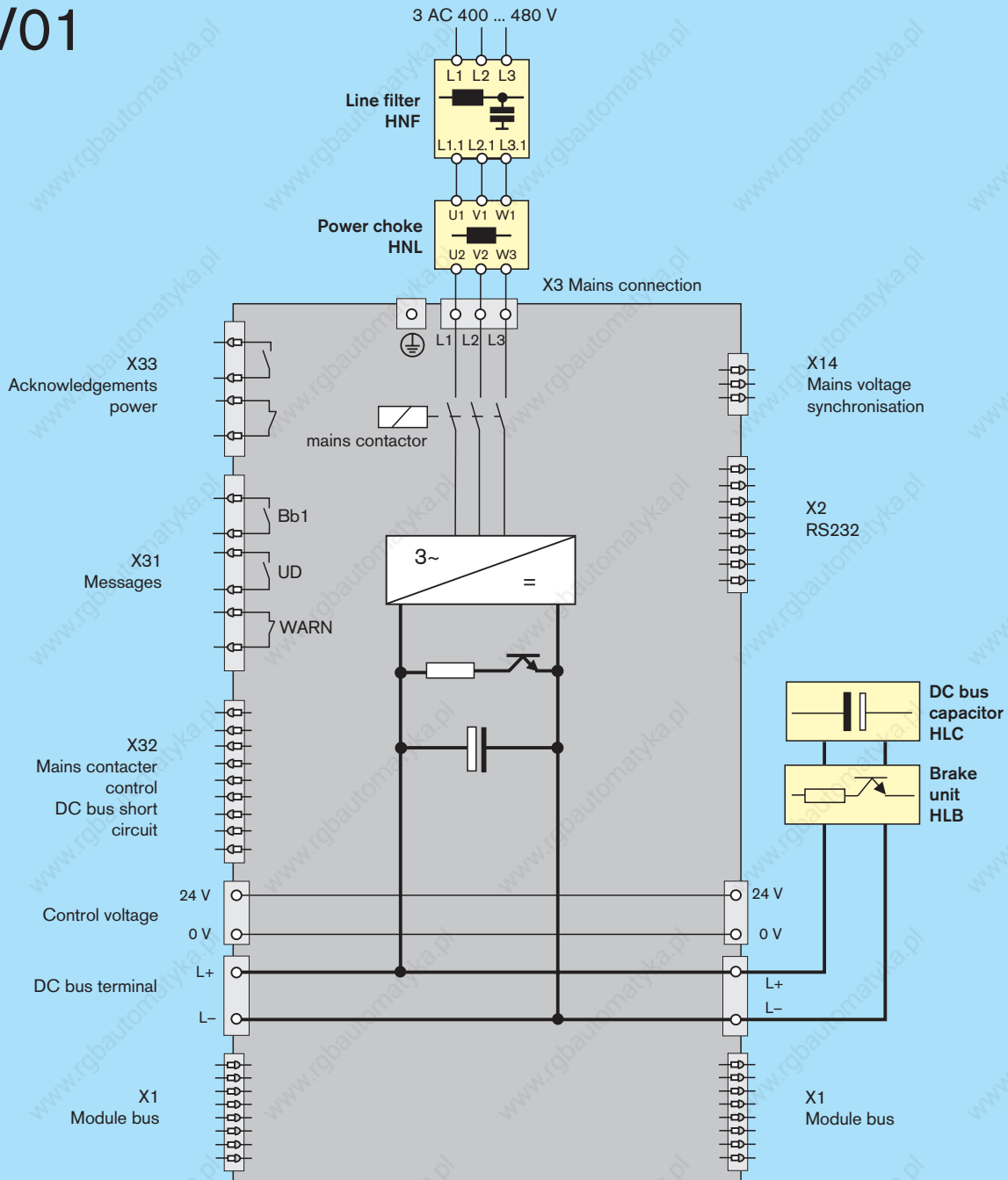

Optional auxiliary component

Power choke HNL always required with HMV01.1R  
 Connection X14 on HMV01.1R only

# Derating under differing operating conditions

Where installation conditions differ, the performance data of the power units decrease according to the capacity utilization factors for:

- Continuous current
- DC bus continuous output
- Continuous braking power

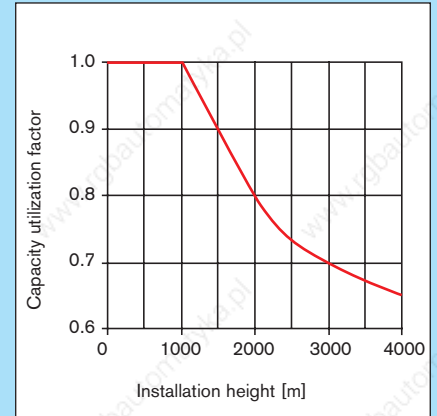
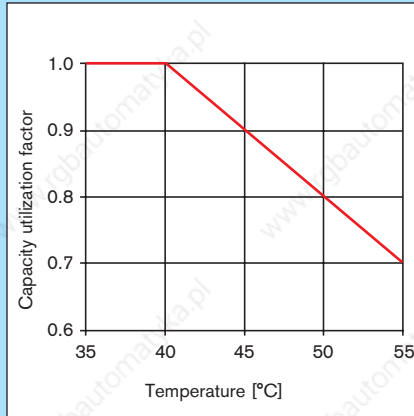

Compared with operation at 4 kHz switching frequency, the output currents of the power units decrease at higher switching frequencies. Please refer to these diagrams for the capacity utilization factors relevant for your application.

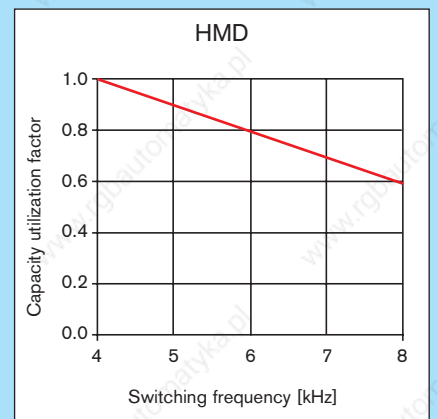
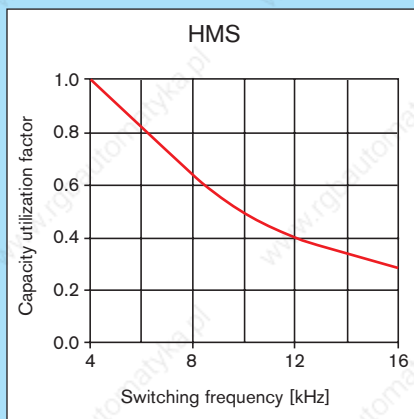
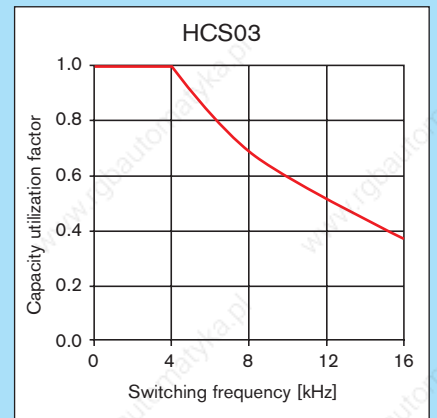
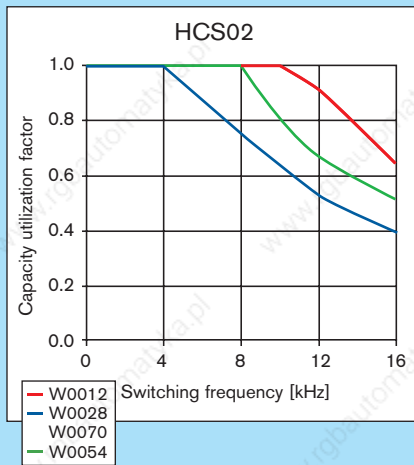



**Rexroth**

IndraDrive M

# Rexroth IndraDrive – control units





## Scalable performance and functionality

- ▮ Individual solutions for standard to high-end applications
- ▮ Integrated Motion Logic with innovative technology functions
- ▮ Open interfaces for international use
- ▮ Certified safety technology

# Your benefits

We can supply control units tailored to your specific application, ranging from standard to high-end applications. Integrated Motion Logic, numerous technology functions, certified safety technology and standardized interfaces leave nothing to be desired.

### BASIC control units – standard performance and functionality

These control units constitute the economic solution for all standard applications with moderate requirements in terms of performance and interface flexibility. A standard feedback interface for IndraDyn motors is already featured among the BASIC control units. The BASIC UNIVERSAL control units have an additional expansion slot available.

The following BASIC control units are available to choose from:

- BASIC OPEN LOOP
- BASIC ANALOG
- BASIC PROFIBUS
- BASIC SERCOS
- BASIC UNIVERSAL – single-axis
- BASIC UNIVERSAL – dual-axis

### ADVANCED control units – maximum flexibility and performance

These control units meet the highest requirements in terms of performance. Virtually any application can be tackled with the wide range of communication and feedback interfaces as well as analog or digital inputs and outputs.

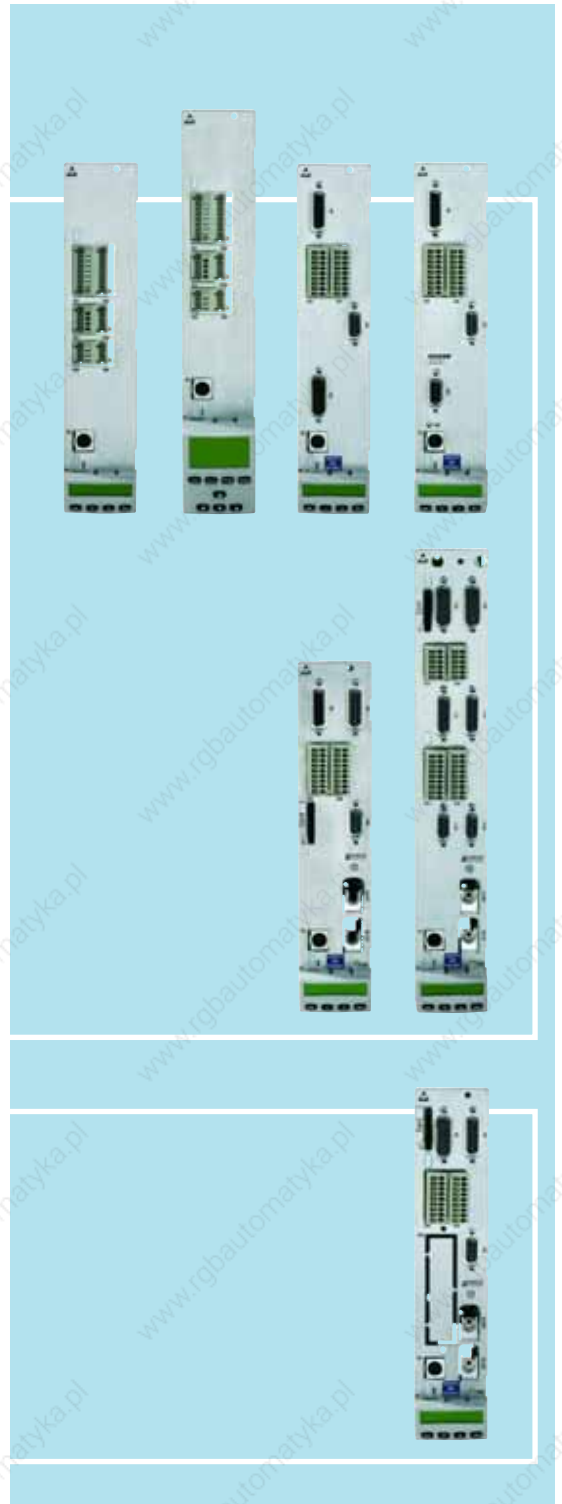

# IndraDrive – scalable performance and functionality

All IndraDrive control units – from the simple frequency converter to the high-end servo drive with integrated Motion Control – are compatible with all IndraDrive C converters and IndraDrive M inverters.

The control units differ in performance, function and configuration. When combined with the various firmware versions and operating panels, every conceivable requirement can be met. This flexible system concept opens up the full range of options when it comes to tackling your individual application – always providing the optimum technical and economical solution.

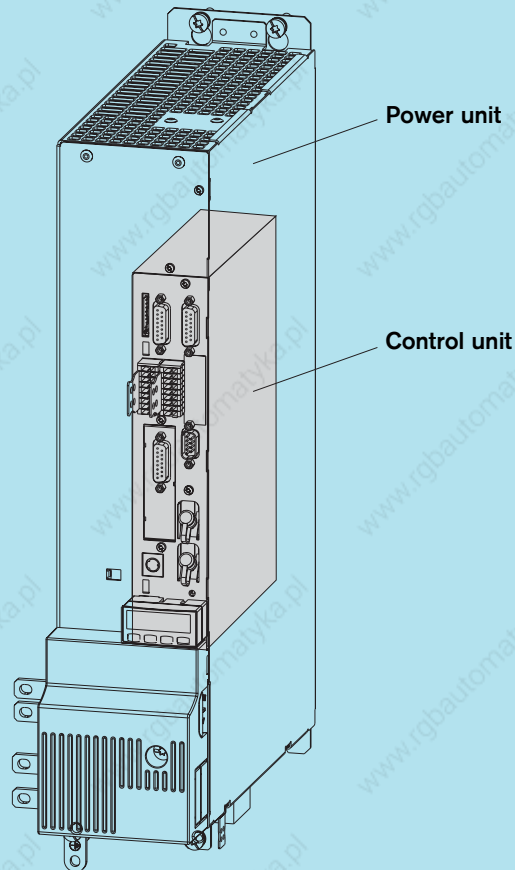

Overview	Single-axis BASIC OPEN LOOP	Single-axis BASIC ANALOG	Single-axis BASIC PROFIBUS	Single-axis BASIC SERCOS	Single-axis BASIC UNIVERSAL	Dual-axis BASIC UNIVERSAL	Single-axis ADVANCED
<b>Control communication</b>							
Analog/digital for OPEN LOOP operation	●	–	–	–	–	–	–
Analog Interface	–	●	–	–	–	–	○ <sup>1)</sup>
Parallel Interface	–	–	–	–	○	○	○
PROFIBUS DP	–	–	●	–	○	○	○
SERCOS interface	–	–	–	●	○	○	○
CANopen	–	–	–	–	○	–	○
DeviceNet	–	–	–	–	○	–	○
PROFINet IO	–	–	–	–	○	○	○
<b>Configurations</b>							
Option 1	–	● <sup>2)</sup>	● <sup>2)</sup>	● <sup>2)</sup>	● <sup>2)</sup>	●/●	●
Option 2	–	–	–	–	●	●/●	●
Option 3	–	–	–	–	–	–	●
Safety option	–	●	●	●	●	●/●	●
Slot for MultiMediaCard	–	–	–	–	●	●	●

Options	Single-axis		Single-axis		Single-axis		Dual-axis		Single-axis
	BASIC OPEN LOOP	BASIC ANALOG	BASIC PROFIBUS	BASIC SERCOS	BASIC UNIVERSAL	BASIC UNIVERSAL	BASIC UNIVERSAL	ADVANCED	
<b>Encoder interfaces</b>									
IndraDyn motors MSK, MAD and MAF Hiperface, 1 V <sub>pp</sub> and 5 V TLL <sup>3)</sup>	-	●	●	●	●	○	○	○	○
MHD, MKD and MKE motors	-	-	-	-	○	○	○	○	○
EnDat 2.1, 1 V <sub>pp</sub> and 5 V TTL <sup>4)</sup>	-	-	-	-	○	○	○	○	○
<b>Safety options compliant with EN 954-1</b>									
Starting lockout compliant with EN 954-1, Cat. 3 for the prevention of unintentional restart	-	○	○	○	○	○	○	○	○
Safety technology conforming to EN 954-1, Cat. 3	-	-	-	-	-	○	○	○	○
<b>Expansions</b>									
Encoder emulation	-	●	-	-	○	○	○	○	○
Analog I/O extension	-	-	-	-	○	○	○	○	○
Digital I/O extension	-	-	-	-	-	-	-	○	○
Digital I/O with SSI encoder interface	-	-	-	-	-	-	-	○	○
Cross communication	-	-	-	-	-	-	-	○	○
<b>Software module</b>									
MultiMediaCard	-	-	-	-	○	○	○	○	○
<b>Operating panel</b>									
Standard	●	●	●	●	●	●	●	●	●
Comfort	○	○	○	○	○	○	○	○	○
<b>Technical data</b>									
Technical data	Single-axis		Single-axis		Single-axis		Dual-axis		Single-axis
	BASIC OPEN LOOP	BASIC ANALOG	BASIC PROFIBUS	BASIC SERCOS	BASIC UNIVERSAL	BASIC UNIVERSAL	BASIC UNIVERSAL	ADVANCED	
<b>Cycle times</b>									
Current control	μs	125						62.5	
Speed control	μs	250						125	
Position control	μs	500						250	
<b>PWM frequency</b>									
4/8 kHz	●/●	●/●	●/●	●/●	●/●	●/●	●/●	●/●	●/●
12/16 kHz	-/-	-/-	-/-	-/-	-/-	-/-	-/-	-/-	●/●
<b>Inputs / outputs</b>									
Digital inputs/of which utilizable for touch probes	8/-	5/-	5/1	5/1	5/1	14/2	7/2	7/2	7/2
Digital inputs/outputs (user-defined settings)	-	4	3	3	3	8	4	4	4
Analog inputs	2	2	-	-	-	1	1	1	1
Analog outputs	2	-	-	-	-	2	2	2	2
Relay outputs	3	1	1	1	1	1	1	1	1
<b>Interfaces</b>									
RS232	●	●	●	●	●	●	●	●	●
<b>Control voltage data</b>									
Control voltage	V	DC 24							
Maximum power consumption	W	18			24		34		26

● Standard ○ Optional <sup>1)</sup>In conjunction with additional options <sup>2)</sup>Feedback interface for IndraDyn motors <sup>3)</sup>Supply voltage 12 V <sup>4)</sup>Supply voltage 5 V

# BASIC OPEN LOOP – for all applications without a feedback

**Interfaces**  
Digital inputs and outputs  
Analog inputs and outputs

**Interfaces**  
Relay outputs

**Interfaces**  
Analog inputs and outputs

**Serial interface**  
RS232

**Option operating panel**  
Standard operating panel  
Comfort operating panel

This control unit is specifically designed for frequency converter applications without a feedback.

The target speed can be set via analog or digital inputs.

Status signals and diagnostic messages are output via digital outputs or isolated relay contacts.

For start-up use either the connected comfort operating panel or a PC with the Rexroth IndraWorks software.

The simple step-by-step guide to ordering your BASIC OPEN LOOP control unit:

**CSB01.1N-FC-NNN-NNN-NN-C-NN-FW**

**Single-axis BASIC**

**Control communication**  
FC = Frequency Converter Interface

**Option**

**Operating panel**  
S = Standard  
C = Comfort

# BASIC ANALOG – cost-effective, proven technology

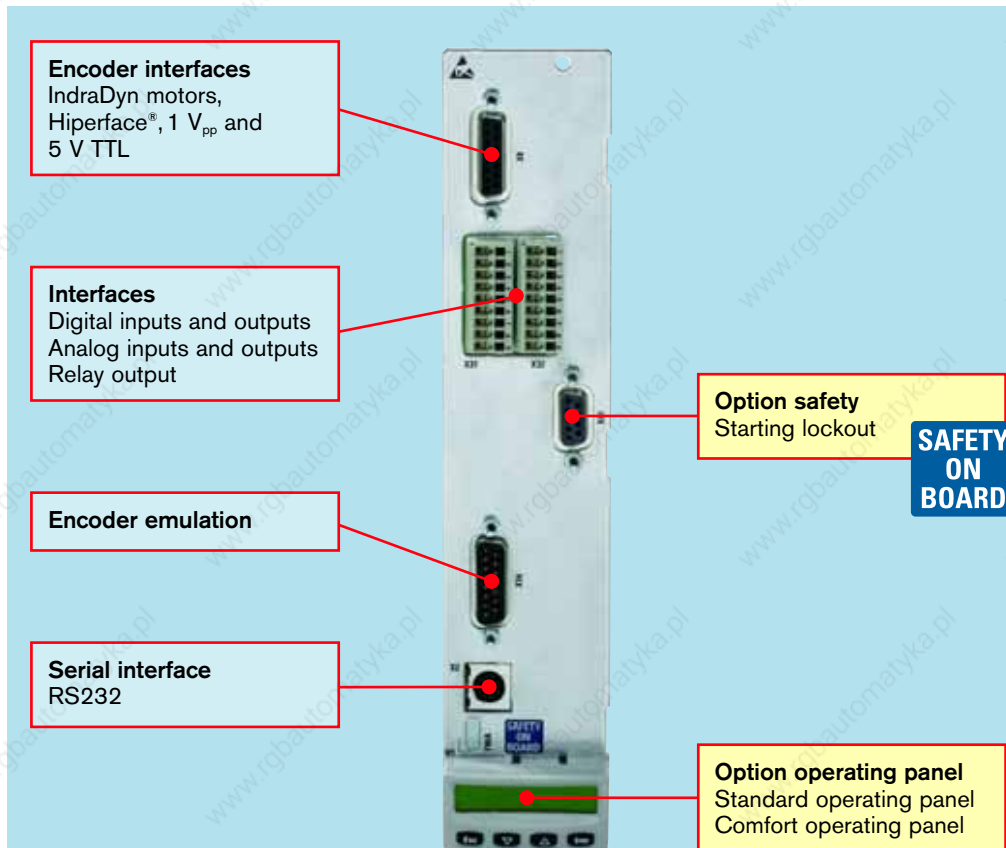

This control component allows you to enjoy the many benefits of digital drive technology on controls with the conventional  $\pm 10$  V analog interface. In addition, it gives you the added option of expanding your control equipment at any time to include other communication interfaces by exchanging the control component while retaining the control cabinet setup.

The default speed is set via the analog input. Signals, such as “Control enable” or “Drive stop”, are exchanged by the control system and control unit via digital inputs and outputs. The encoder emulation inside the drive system-izes the actual positions for the control system. There is a choice between the straightforward incremental encoder signal or SSI format.

The correct interface for connecting the IndraDyn motors or other standardized encoders, such as Hiperface, is already integrated.

The simple step-by-step guide to ordering your BASIC ANALOG control unit:

**CSB01.1N-AN-ENS-NN-L1-S-NN-FW**

Single-axis BASIC

Control communication  
AN = Analog interface

Encoder interface  
ENS = IndraDyn motors, Hiperface® etc.

Option

Safety technology  
L1 = with starting lockout  
NN = without starting lockout

Operating panel  
S = Standard  
C = Comfort

# BASIC PROFIBUS – ideal for factory automation

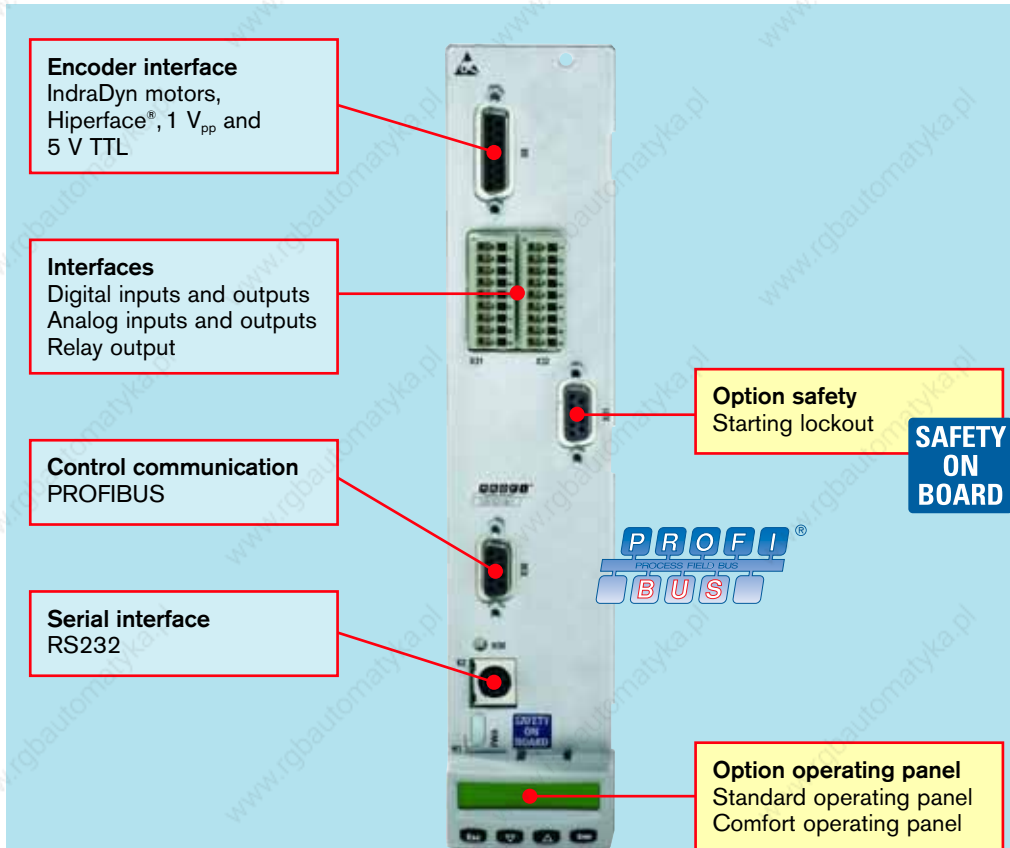

The PROFIBUS fieldbus interface has been used successfully for many years in automated manufacturing technology and process automation.

This bus system is the means by which the control system cyclically exchanges with the bus users all the specified and actual values, including status signals and diagnostic messages.

The correct interface for connecting the IndraDyn motors or other standardized encoders, such as Hiperface, is already integrated.

Start-up with the engineering tool IndraWorks is a convenient option via PROFIBUS. Alternatively, the drive can also be started up via the comfort operating panel.

The simple step-by-step guide to ordering your BASIC PROFIBUS control unit:

**CSB01.1N-PB-ENS-NN-L1-S-NN-FW**

Single-axis BASIC

Control communication  
PB = PROFIBUS

Encoder interface  
ENS = IndraDyn motors, Hiperface® etc.

Option

Safety technology  
L1 = with starting lockout  
NN = without starting lockout

Operating panel  
S = Standard  
C = Comfort

# BASIC SERCOS – precise and cost-effective

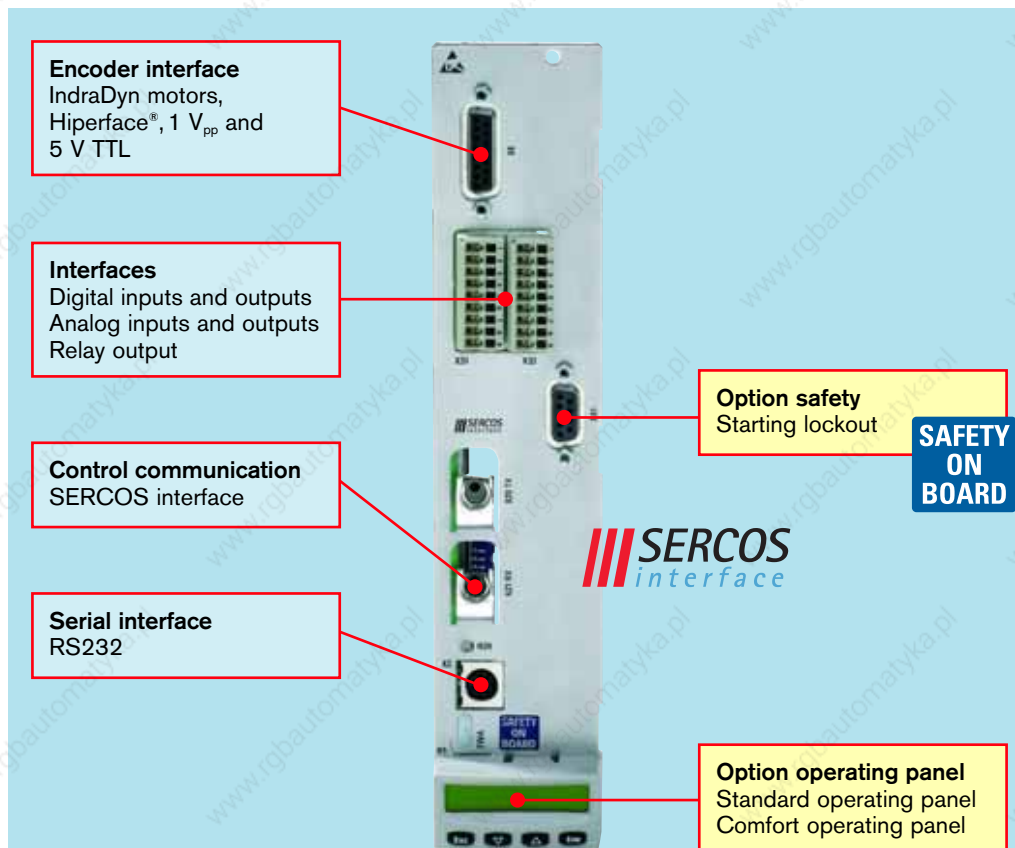

Only with the SERCOS interface<sup>1)</sup> can you benefit from all the advantages of digital intelligent drive technology. One distinguishing feature of SERCOS is its extremely short cycle time with which all target and actual values are transferred between the control system and control units. In conjunction with the exact synchronization of all drives, the SERCOS interface guarantees maximum dynamics and precision.

Signal transfer via fiber optics guarantees the secure exchange of real-time data with minimal wiring.

The correct interface for connecting the IndraDyn motors or other standardized encoders, such as Hiperface, is already integrated.

With the engineering tool, IndraWorks, one convenient start-up option is via the SERCOS service channel and the other is via the RS232 interface.

The simple step-by-step guide to ordering your BASIC SERCOS control unit:

**CSB01.1N-SE-ENS-NN-L1-S-NN-FW**

Single-axis BASIC

Control communication  
SE = SERCOS interface

Encoder interface  
ENS = IndraDyn motors, Hiperface® etc.

Option

Safety technology  
L1 = with starting lockout  
NN = without starting lockout

Operating panel  
S = Standard  
C = Comfort

<sup>1)</sup> SERCOS interface, the internationally standardized drive interface (IEC 61491/ EN 61491) facilitates optimum compatibility of digital drives and controls made by different manufacturers while exploiting the respective product attributes to maximum effect.

# BASIC UNIVERSAL single-axis – flexible for customized solutions

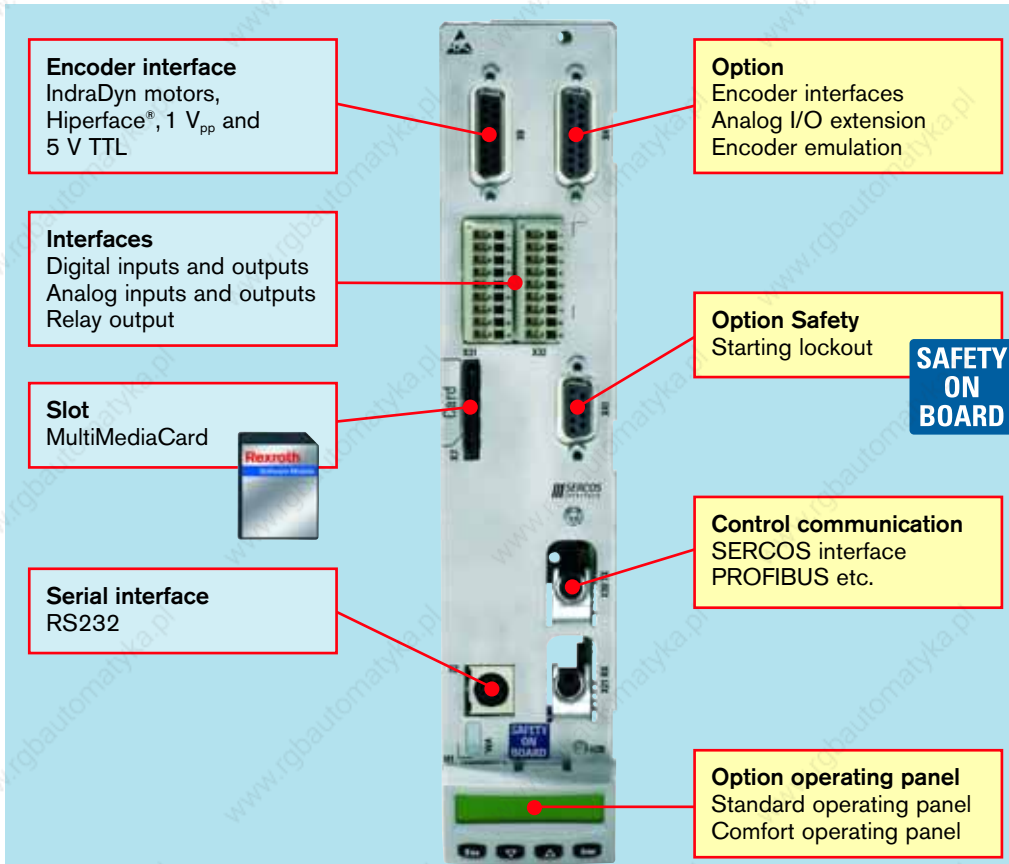

Regardless of your preferred type of control communication, BASIC UNIVERSAL offers you a wide range of industry-standard interfaces. As a result, this control unit is well suited for a variety of applications – including those in your industry.

The correct interface for connecting the IndraDyn motors or other standardized encoders, such as Hiperface, is already integrated. In addition, this control unit has an empty slot for the connection of another encoder, connection of the analog I/O extension or for the emission of emulated encoder signals.

An additional plug-in Multi-MediaCard gives you the option of simple transmission or duplication of your axis-oriented drive parameters. This card can also be used to expand the memory for the Motion Logic integrated in the drive (firmware option).

For start-up, you can use either the connected comfort operating panel or a PC with the Rexroth IndraWorks engineering tool.

The simple step-by-step guide to ordering your BASIC UNIVERSAL single-axis control unit:

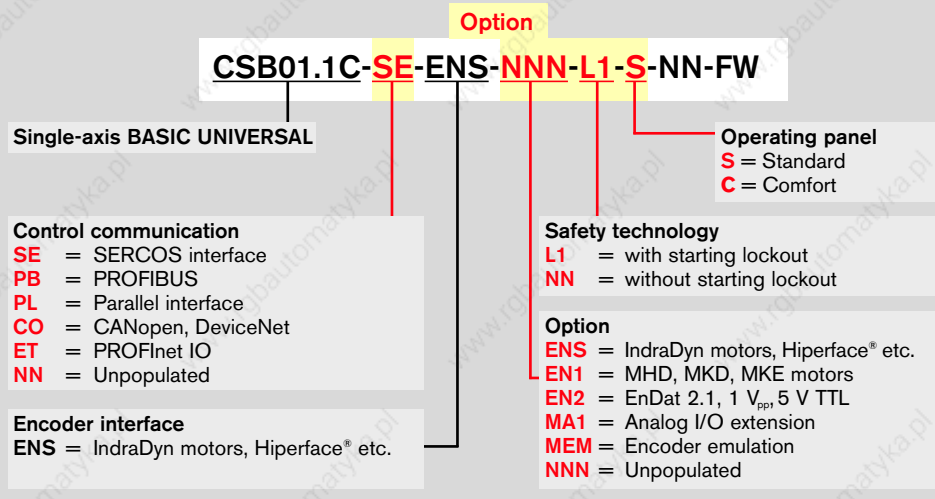

# BASIC UNIVERSAL dual-axis – flexible, reliable, space-saving

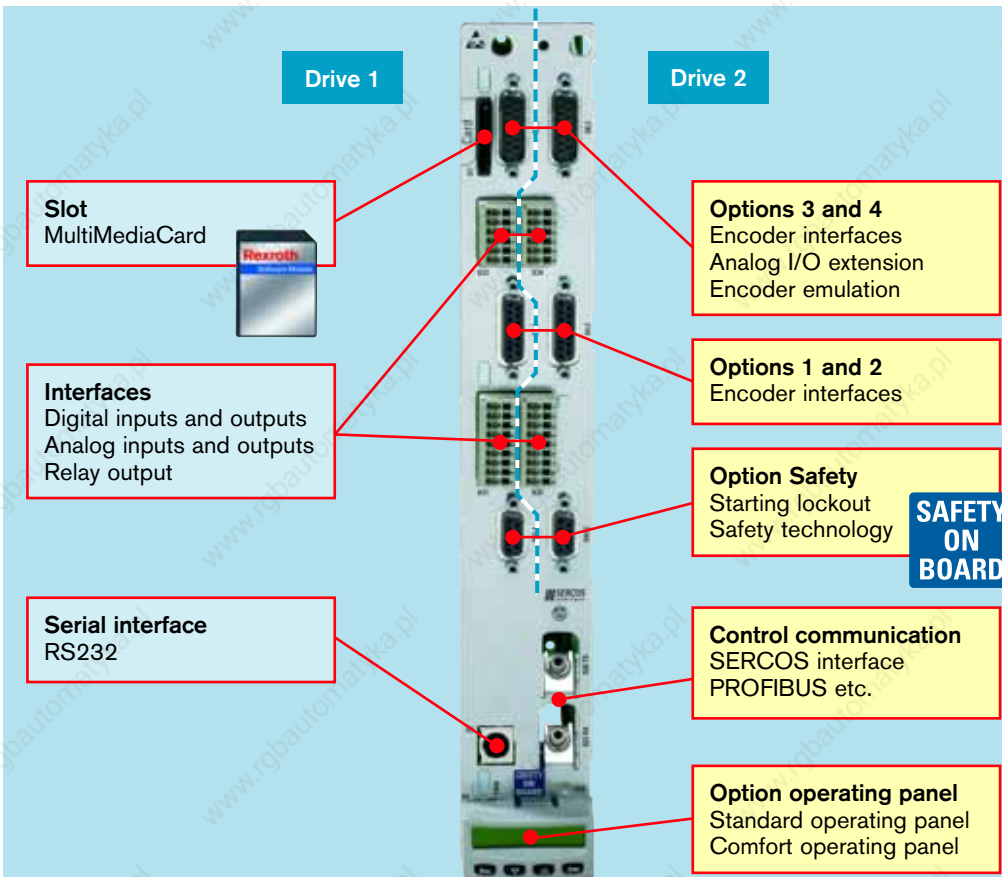

Many axes and limited installation space – these are typical requirements that can be met competently and economically with the BASIC UNIVERSAL dual-axis control unit. With the BASIC UNIVERSAL dual-axis, we have implemented all the functionality for two digital axes in a single control unit. The benefit for you is that, even if there are severe space constraints, you can integrate a number of drives thus minimizing your control cabinet footprint.

With certified safety technology conforming to EN 954-1, Category 3, you are providing effective protection for both the machine and operator. Indeed, we have integrated a number of different safety functions, such as “Safe stop” and “Safe motion”, directly in the drive. This increases reliability while saving on monitoring components and minimizing installation work.

In terms of control communication you can choose between SERCOS interface, PROFIBUS and PROFINET IO. In the interests of meeting the specific demands of your individual application, IndraDrive offers additional options for the connection of various feedback systems, the connection of an analog I/O extension or for the emission of emulated encoder signals.

The dual-axis control unit offers the ability of storing the axis-oriented drive parameters of both axes on the optional MultiMediaCard. For start-up use the engineering tool IndraWorks or the comfort operating panel.

The simple step-by-step guide to ordering your BASIC UNIVERSAL dual-axis control component:

**CDB01.1C-SE-ENS-EN2-NNN-MA1-S1-S-NN-FW**

Dual-axis BASIC UNIVERSAL

**Control communication**

- SE** = SERCOS interface
- PB** = PROFIBUS
- ET** = PROFINET IO
- NN** = Unpopulated

**Options 1 and 2**

- ENS** = IndraDyn motors, Hiperface® etc.
- EN1** = MHD, MKD, MKE motors
- EN2** = EnDat 2.1, 1 V<sub>pp</sub>, 5 V TTL
- NNN** = Unpopulated

**Operating panel**

- S** = Standard
- C** = Comfort

**Safety technology**

- L1** = with starting lockout
- S1** = without starting lockout
- NN** = without safety technology

**Options 3 and 4**

- ENS** = IndraDyn motors, Hiperface® etc.
- EN1** = MHD, MKD, MKE motors
- EN2** = EnDat 2.1, 1 V<sub>pp</sub>, 5 V TTL
- MA1** = Analog I/O extension
- MEM** = Encoder emulation
- NNN** = Unpopulated

# ADVANCED – the security of maximum performance and flexibility

**Slot MultiMediaCard**  
Flexroth

**Interfaces**  
Digital inputs and outputs  
Analog inputs and outputs  
Relay output

**Serial interface RS232**

**Option operating panel**  
Standard operating panel  
Comfort operating panel

**Option 1**  
Encoder interface

**Option 2**  
Encoder interface  
Analog I/O extension  
Encoder emulation

**Option safety**  
Starting lockout  
Safety technology

**Option 3**  
Encoder interfaces  
Analog I/O extension  
Encoder emulation  
Digital I/O extension  
Cross communication

**Control communication**  
SERCOS interface  
PROFIBUS etc.

**SAFETY ON BOARD**

ADVANCED control units meet the highest demands in performance and dynamics.

In addition to top performance, they support a wide and diverse range of control communication and encoder interfaces. Digital and analog inputs and outputs are already permanently integrated for communication with higher level control systems. These can also be expanded by digital or analog I/O extensions or by encoder emulation outputs. This high-performance control unit can be optionally equipped with safety technology certified as conforming to EN 954-1, Category 3. The ADVANCED control unit is the ideal platform for the drive-integrated PLC, IndraMotion MLD.

All that is required to start up the drive is a PC and the engineering tool IndraWorks or a connected comfort operating panel.

The simple step-by-step guide to ordering your ADVANCED control component:

**Option**  
**CSH01.1C-SE-ENS-EN2-NNN-S1-S-NN-FW**

Single-axis ADVANCED

**Control communication**

- SE** = SERCOS interface
- PB** = PROFIBUS
- PL** = Parallel interface
- CO** = CANopen, DeviceNet
- ET** = PROFINet IO
- NN** = Unpopulated

**Option 1 (encoder interface)**

- ENS** = IndraDyn motors, Hiperface® etc.
- EN1** = MHD, MKD, MKE motors
- EN2** = EnDat 2.1, 1 V<sub>pp</sub>, 5 V TTL
- NNN** = Unpopulated

**Option 2**

- ENS** = IndraDyn motors, Hiperface® etc.
- EN1** = MHD, MKD, MKE motors
- EN2** = EnDat 2.1, 1 V<sub>pp</sub>, 5 V TTL
- MA1** = Analog I/O extension
- MEM** = Encoder emulation
- NNN** = Unpopulated

**Safety technology**

- L1** = with starting lockout
- S1** = with I/O safety technology
- NN** = without safety technology

**Option 3**

- ENS** = IndraDyn motors, Hiperface® etc.
- EN1** = MHD, MKD, MKE motors
- EN2** = EnDat 2.1, 1 V<sub>pp</sub>, 5 V TTL
- MA1** = Analog I/O extension
- MEM** = Encoder emulation
- MD1** = Digital I/O extension
- MD2** = Digital I/O with SSI encoder interface
- CCD** = Cross communication
- NNN** = Unpopulated

**Operating panel**

- S** = Standard
- C** = Comfort

# Accessories – advantages for your control unit

These components can help you to capitalize on your drive – during start-up, operation and diagnostics.

## Operating panels

All control units are equipped with a standard plug-in operating panel. An optional extra is a comfort operating panel with graphics capabilities. This will guide you quickly and confidently through all the start-up steps – no PC is required. Moreover, the comfort operating panel offers the capability of transmitting the drive parameters from one drive to another – quickly and easily.



## Separate control terminals

For complex applications, especially in conjunction with the drive-integrated Motion Logic, we recommend the use of our compact control terminals IndraControl VCP. Connection is via the drive's serial interface.

From the simple text display right through to the graphics-capable touch screen, it always provides a particularly cost-effective solution for operation and visualization.



## Software module

The optional MultiMediaCard allows you to transmit or duplicate your axis-oriented drive parameters quickly and easily – without a PC.



This software module comes in two versions:

- PFM02.1-016-NN-FW with drive firmware
- PFM02.1-016-NN-NW preformatted for simple parameter transfer

## Interface cable

For start-up or operation connect your PC or a separate control terminal directly to the RS232 serial interface of the control unit.

The appropriate IKB0041 cable can be obtained ready-made in 2, 5, 10 or 15 m lengths.



# Overview of interfaces

## Control communication

### Analog/digital for OPEN LOOP operation

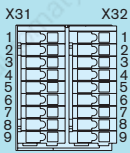

- 2 x 9-pin plug-in terminals
- 8 digital inputs

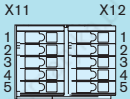

- 2 x 5-pin plug-in terminals
- 3 relay outputs (24 V DC and 230 V AC)

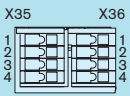

- 2 x 4-pin plug-in terminals
- 2 analog inputs
  - 2 analog outputs

### Analog interface

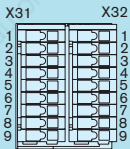

- 2 x 9-pin plug-in terminals
- Analog inputs  $\pm 10$  V
  - Digital inputs/outputs
  - Relay output

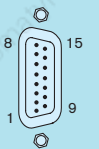

- D-SUB, 15-pin, pins on device
- Encoder emulation, incremental or absolute (SSI)
  - Output frequency max. 1 MHz

### Parallel interface

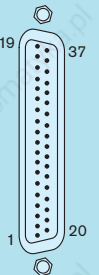

- D-SUB, 37-pin, pins on device
- 16 inputs, reverse polarity protected
  - 16 outputs, short-circuit proof
  - DC-isolated

Also suitable for input/output expansion in conjunction with IndraMotion MLD

### SERCOS interface



- 2 x fiber optic cable connections

- Choice of transfer rates  
2, 4, 8 or 16 Mbaud

### PROFIBUS DP

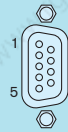

- D-SUB, 9-pin,  
ports on the device

### CANopen/DeviceNet



- Open-style connector, 5-pin

- Selector switch for CANopen or DeviceNet

### PROFINet IO



- RJ45 plug-in connection

## Encoder interfaces

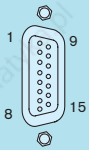

**ENS** encoder interface for IndraDyn motors, Hiperface®, 1 V<sub>pp</sub>, 5 V TTL

- D-SUB, 15-pin, ports on device
- Encoder supply: 11.6 V/300 mA

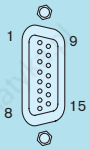

**EN1** encoder interface for MHD, MKD and MKE motors

- D-SUB, 15-pin, ports on device
- Encoder supply I<sup>2</sup>C: 8 V/250 mA or resolver: 18.2 V/70 mA

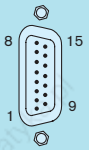

**EN2** encoder interface for EnDat 2.1, 1 V<sub>pp</sub>, 5 V TTL

- D-SUB, 15-pin, pins on device
- Encoder supply: 5 V/300 mA

## Input/output extensions

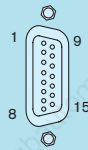

Analog I/O extension **MA1**

- D-SUB, 15-pin, ports on device
- 2 analog input ports ± 10 V
  - 14 bit incl. 8-time oversampling
  - 2 analog 12 bit output ports

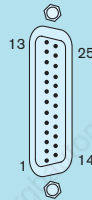

Digital I/O extension **MD1**

- D-SUB, 25-pin, pins on device
- External voltage supply from 19 V to 30 V
  - 12 inputs, reverse polarity protected
  - 8 outputs, short-circuit proof



Digital I/O with SSI interface **MD2**

- D-SUB, 44-pin, pins on device
- External voltage supply from 19 V to 30 V
  - 16 inputs, reverse polarity protected
  - 16 outputs, short-circuit proof

RJ11 plug-in connection for SSI measuring encoder interface

## Encoder emulation

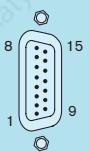

Encoder emulation **MEM**

- D-SUB, 15-pin, pins on device
- Internal voltage supply
  - Encoder signals DC-isolated
  - Incremental or Absolute (SSI format)
  - Output frequency max. 1 MHz

## Cross communication



Cross communication **CCD**

- 2 x RJ45 plug-in connection
- Master for connection of up to 5 slaves (SERCOS III)

## Safety

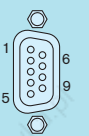

Starting lockout **L1**

- D-SUB, 9-pin, ports on device
- Supply voltage 24 V DC
  - Drive signals A, B and inverse
  - Acknowledgement
  - Acknowledgement, inverse

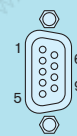

Safety technology **S1**

- D-SUB, 9-pin, ports on device
- Supply voltage 24 V DC
  - Mode selection panel inputs
  - Acknowledgement, forced dormant error detection and diagnostics/safety door lock

# Rexroth IndraDrive – firmware

The firmware can be tailored to your specific application in a number of flexible configurations:

- Basic OPEN LOOP package (frequency converter applications)
- Basic CLOSED LOOP package (servo and frequency converter applications)
- Extension packages (optional)
- Motion Logic (IndraMotion MLD optional)

The basic package is already sufficient to perform the majority of standard drive functions – from simple V/f control right through to positioning block mode.

Various extension packages provide you with the options of electronic synchronization, additional servo functions or main spindle operation.

The freely-programmable Motion Logic with integrated PLC conforming to IEC 61131-3 and ready-to-use technology functions enable simple execution of complex machine processes.

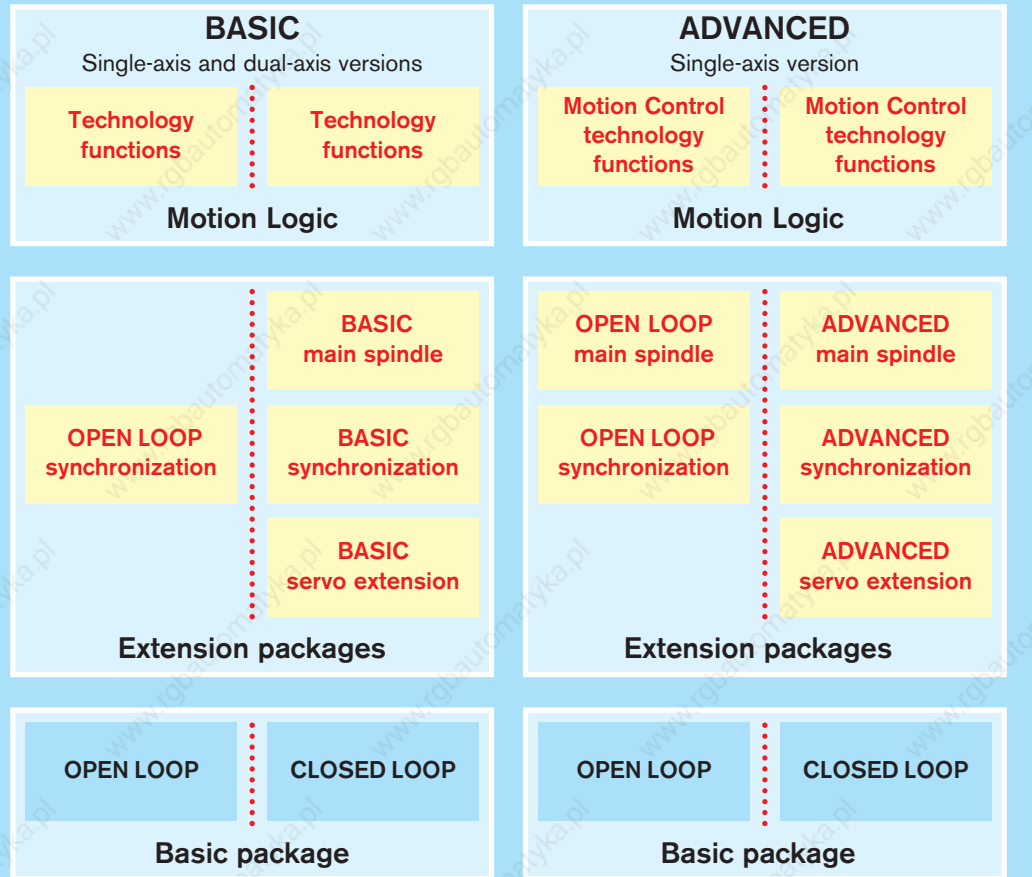

The simple step-by-step guide to ordering your IndraDrive firmware:

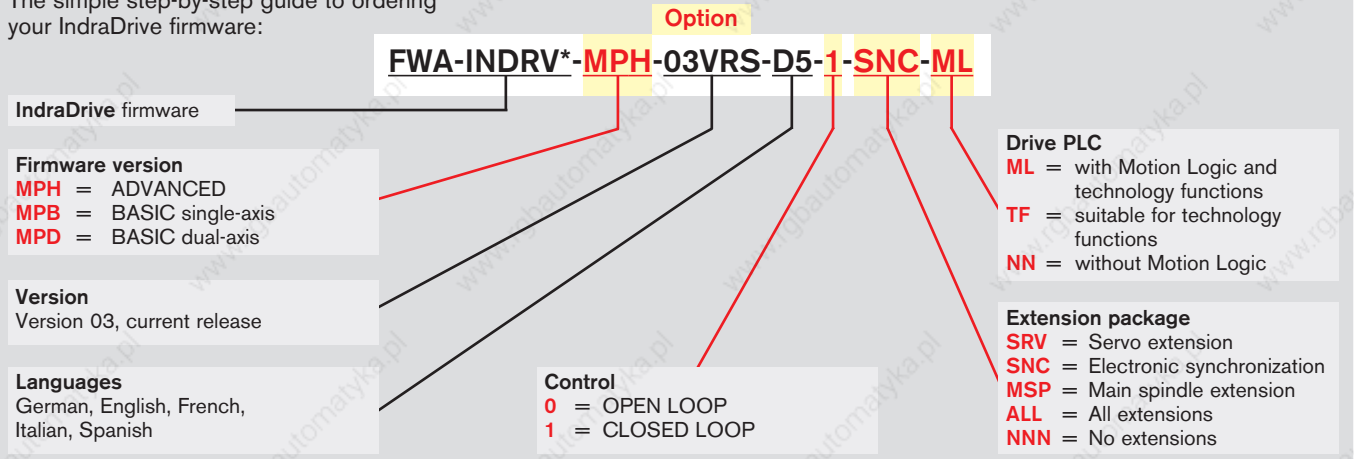



## Customized functionality

- ! All standard functions already included in basic package
- ! Individual function extensions
- ! Industry-specific technology functions
- ! Integrated IEC-compliant Motion Logic

# Your benefits

Basic package	BASIC		ADVANCED	
	OPEN LOOP	CLOSED LOOP	OPEN LOOP	CLOSED LOOP
<b>Basic functions</b>				
General motor control with V/f curve, incl. slip compensation				
I x R compensation and stall protection				
Field-oriented control, without feedback				
Electronic type plate				
Automatic control circuit adjustment	●	●	●	●
Setpoint generator for control optimization				
Travel to fixed stop				
Adjustable error response				
Brake control				
Oscilloscope function				
<b>Basic functions OPEN LOOP</b>				
Speed ramp generator	●	●	●	●
Motorized potentiometer function				
<b>Basic functions CLOSED LOOP</b>				
Position, speed and torque control				
Drive-controlled referencing				
Drive-controlled positioning				
Interpolation inside drive				
Positioning block mode				
Position, speed and torque limit	-	●	-	●
Travel to fixed stop				
Automatic commutation adjustment				
Path switching point with ON and OFF switching threshold				
Encoder emulation, incremental or absolute (SSI format)				

Extension packages	BASIC		ADVANCED	
	OPEN LOOP	CLOSED LOOP	OPEN LOOP	CLOSED LOOP
<b>Servo extension</b>				
Easy compensation of backlash on reversal	-	●	-	●
Axis error correction	-	-	-	●
Quadrant error correction	-	-	-	●
Frictional torque compensation	-	●	-	●
Touch probe with fast stop	-	1	-	2
Dynamic cam group	-	●	-	●
<b>Main spindle</b>				
Parameter block changeover	●	●	●	●
Spindle positioning mode	-	●	-	●
Drive-controlled gear changes	-	-	-	●
<b>Synchronization</b>				
Speed synchronization	●	●	●	●
Angle synchronization	-	●	-	●
Measuring wheel mode	-	●	-	●
Real and virtual leading axis	●	●	●	●
Cam plate (tabular value)	-	●	-	●
Cam plate (analytical value)	-	-	-	●
Touch probe with time measurement	1	-	1	-
Touch probe with synchronization function	-	1	-	2
Dynamic cam group	-	●	-	●

Motion Logic	BASIC		ADVANCED	
	OPEN LOOP	CLOSED LOOP	OPEN LOOP	CLOSED LOOP
<b>IndraMotion MLD</b>				
Freely programmable in compliance with IEC 61131-3				
Programming system for IL, ST, FBD, LD and SFC				
4 user tasks (periodic, unsolicited or event-controlled)	● <sup>1)</sup>	● <sup>1)</sup>	●	●
Libraries: system-specific, drive-specific, PLCopen				
Support of customer libraries				
Process-oriented technology packages				

<sup>1)</sup>BASIC control units are restricted in terms of performance

# Rexroth IndraMotion MLD – integrated Motion Logic

## The world's first open drive

With IndraMotion MLD drive functions, motion control and processing logic merge to form a modern open automation platform for modular machine concepts. The drive-integrated Motion Logic reduces or even eliminates the need for higher-level control systems.

## Open standards

Standardized programming languages and the integrated engineering framework IndraWorks simplify project planning, programming, operation and diagnostics. At the same time you are directly investing your valuable know-how in the drive and thereby safeguarding your competitive edge. Programming is in compliance with IEC 61131-3 in the following languages:

- Instruction list (IL)
- Structured text (ST)
- Functional block diagram (FBD)
- Ladder diagram (LD)
- Sequential function chart (SFC)

The availability of standardized modules in the PLCopen-compliant function library gives you access to a multitude of motion functions.

## Flexible programming

With user-definable programming you have the freedom and flexibility to configure your application to your requirements. Indeed, you have the latitude to combine innovative drive functions, extensive function libraries and process-oriented technology packages into one perfect automation solution.

## Achieve your goals faster

Even large-scale and complex applications can be handled with ease with our ready-to-use function blocks and predefined technology packages. Combine them to form your own user program or simply use them as configurable functions.

Examples of items:

- PLCopen modules
- Cam group
- Print-mark control
- Register control
- Tension control
- Loop control
- Winder
- Demand processing
- Extended drive functions:
  - Variable retraction motion
  - Adaptive feedrate control
  - Analog force control and much more

## Innovative modules for any application

- Functions library: Collection of function blocks conforming to IEC or PLCopen
- User library: Collection of function blocks developed by the user
- Technology packages: Process-oriented function blocks, e.g. tension control
- User program: Application-specific combination of different function blocks and technology packages

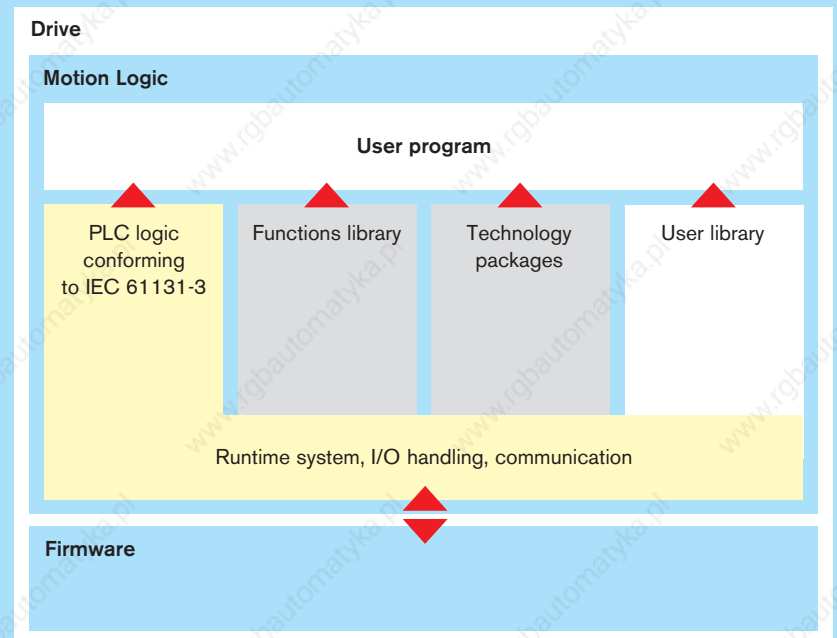

## Drive and control system seamlessly coordinated

- Highly-economic solution for single-axis and multi-axis applications without additional hardware
- Minimized engineering thanks to IEC- and PLCopen-compliant configuration
- Predefined technology packages for faster implementation of system solution

# Your benefits

### Single-axis solution

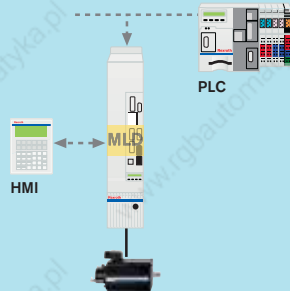

**IndraMotion MLD-S**  
Integrated Motion Logic

### Multi-axis solution

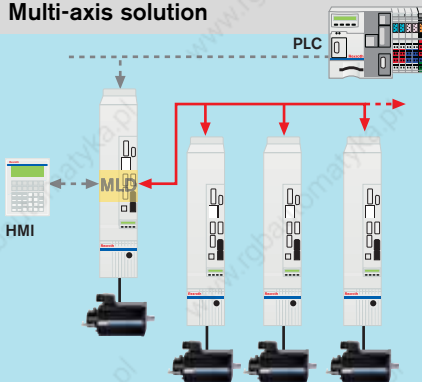

**IndraMotion MLD-M**  
Integrated Motion Logic with cross communication

### Achieve your goals faster with standards

The drive-based Motion Logic eliminates the need for higher-level control systems. Standardized programming languages and interfaces also help keep training and engineering costs to a minimum.

By employing ready-to-use function libraries and technology packages you can benefit from available know-how to further reduce engineering costs. You can contribute your own valuable know-how directly to the drive, thereby singling yourself out from your competitors.

IndraMotion MLD	MLD-S BASIC	MLD-S ADVANCED	MLD-M ADVANCED
Number of axes	1	1	up to 6
Hardware requirement (master)	BASIC control unit CSB	ADVANCED control unit CSH	ADVANCED control unit CSH with option CCD
Firmware option	TF	ML	ML
<b>Performance</b>			
	Depends on the utilization of the BASIC drive	100 µs per 1,000 instructions in IL using bit and word processing	
<b>Tasks</b>			
Number of tasks	4		
Types of task	Periodic, unsolicited or event-controlled		
Cycle time	ms	2	1
<b>Program memory</b>			
Firmware 03VRS	kB	192	
Firmware 04VRS	kB	approx. 350	
<b>Retain data memory</b>			
on control component	Byte	248	248
with option MD1 or MD2 using firmware 03VRS	kB	-	32
with option MD1 or MD2 using firmware 04VRS	kB	-	64
<b>Programming</b>			
Programming system	Rexroth IndraWorks		
Programming languages	Instruction list (IL), Structured text (ST), Functional block diagram (FBD), Ladder diagram (LD) or Sequential function chart (SFC)		
Programming interfaces	RS232 (Ethernet under development)		
Program debug functions	Breakpoint, single step, single cycle, write/force, monitoring, sampling trace, simulation, online change		
Libraries supplied	System-specific, drive-specific and PLCopen		
<b>Control communication</b>			
	SERCOS interface, PROFIBUS, PROFINet IO, DeviceNet, CANopen, parallel interface analog interface, analog/digital for OPEN LOOP mode, IndraMotion MLD		
<b>Digital inputs and outputs</b>			
Inputs	5 <sup>1)</sup>	7	Depends on the number and type of control units and options used
Inputs/outputs (user-defined settings)	3 <sup>1)</sup>	4	
Option MD1	-	12 I/8 O	
Option MD2	-	16 I/16 O	
Parallel interface	16 I/16 O	16 I/16 O	
<b>Analog inputs and outputs</b>			
on control unit	- <sup>1)</sup>	1 I/2 O	Depends on the number and type of control units and options used
with option MA1	2 I/2 O	2 I/2 O	

<sup>1)</sup> Applies to control unit CSB01.1C

# Safety on board – integrated safety technology

Whether for machine tools, printing and packaging or mounting, handling and robotics applications – protecting people from uncontrolled machine movements is top priority.

## Clear guidelines issued by the EU

All machine manufacturers are obliged to carry out a hazard evaluation and risk analysis prior to construction. This is stipulated in the European Machinery Directive 98/37/EC. Moreover, any potential hazards detected must be eliminated step by step. Safety should be integrated in the machinery and meet current standards in technology.

## How safe can you get?

IndraDrive is redefining current standards in technology because IndraDrive integrates the safety directly in the drive, resulting in ultra-short response times. IndraDrive therefore demonstrates the current capacities and requirements of safety technology – IndraDrive is faster because the movement is monitored directly where it is generated. This is the critical advantage, especially when it comes to monitoring direct drives or other high-dynamic drives, for example.

## Quickest reaction time with highest drive dynamics

With the new IndraDrive generation from Rexroth, a variety of safety functions are available right inside the drive – without any detours through the control. This increases reliability, saves on additional monitoring components and reduces installation cost and effort.

## Axis movements minimized thanks to ultra-short response times

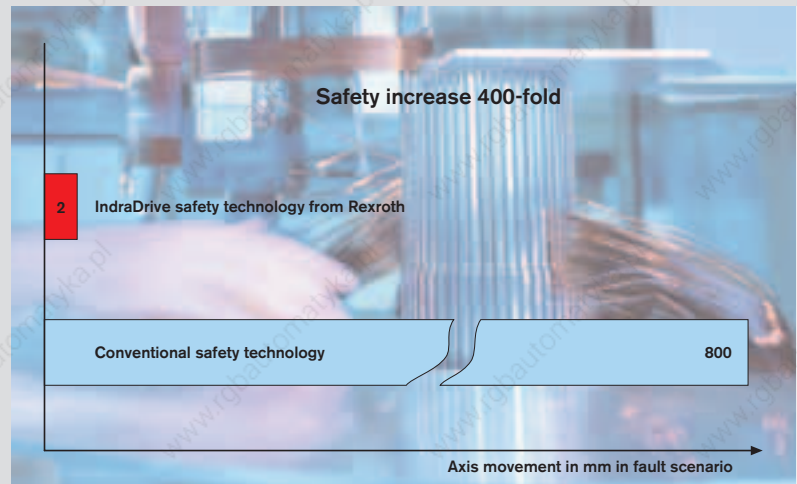

Before a user in the protected area reacts to an error with an acknowledgment linked to contacts, a linear axis with a ball screw has already traveled 100 to 200 mm, linear motors have

already traveled 400 to 800 mm. IndraDrive safety technology finds the error within 2 ms and the axis moves only 2 mm.

It is all made possible by redundant software and hardware components in the drive. The non-contacting monitoring of all set limit values enables very short response times of less than 2 ms. As soon as a fault is detected, all the drives are automatically stopped depending on the stop category selected (0, 1 or 2).



Our safety technology is verified by an accredited organization and certified as conforming to EN 954-1, Category 3.



## Intelligent and safe

- ! Safety category 3 certified as conforming to EN 954-1
- ! Extensive safety functions
- ! Minimum response times
- ! Independent of the control system
- ! Straightforward integration in the machine

# Your benefits

### Safety functions inside the drive effectively protect people and machines

- High reliability due to certified integrated safety functions according to EN 954-1, Category 3
- Extremely fast reaction times (< 2 ms) for communication with internal monitors
- No need for additional measuring systems or sensors
- Suitable for use with any higher-level control systems
- Online dynamic sampling of the inputs and shutoff paths while work is in progress
- Non-time-critical selection of the safety functions, e.g. by the PLC
- PROFIsafe interface with reduced configuration and installation effort
- The customer saves on certification costs
- Short series start-up times and minimum handling during service

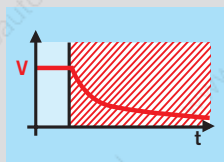

#### Safe start lockout

(Stop category 0 as per EN 60204-1)  
Torque cut-off for drives; drives are safely disconnected from the power supply.

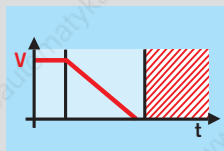

#### Safe stop

(Stop category 1 as per EN 60204-1)  
Monitored shutdown – controlled by controller or drive, torque-free shutdown of drives, drives are safely disconnected from the power supply.

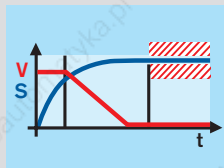

#### Safe operation stop

(Stop category 2 as per EN 60204-1)  
Monitored shutdown – controlled by controller or drive. Shuts down the drives while maintaining all the control functions.

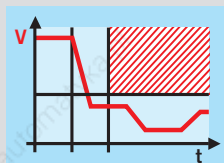

#### Safe speed reduction

When acknowledgement is given, a safely reduced speed can be used for travel in a special operating mode.

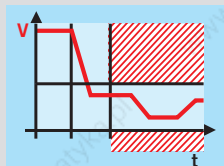

#### Safe direction of rotation

In addition to a safely reduced speed it is also possible to define a safe direction of rotation.

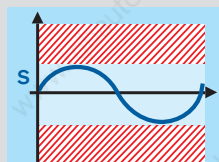

#### Safe absolute position range

In addition to the safely reduced speed and/or safe direction of rotation, it is also possible to select a safe absolute position range.

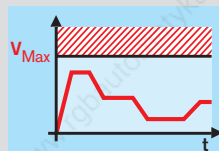

#### Safe maximum speed limit

The maximum speed is safely monitored regardless of the mode of operation.

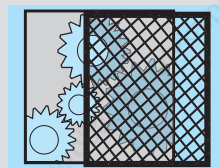

#### Safe guard door lock

When all the drives in one zone are in safe state, the guard door lock is released.

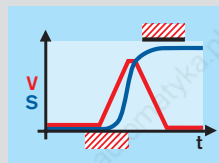

#### Safe increment limit

When acknowledgement is given, a safely limited increment can be used for travel in a special operating mode.

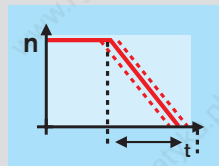

#### Safe shutdown monitoring

This function can be implemented using safely monitored shutdown time or safely monitored delay time and predictive monitoring.

# Safety on board – be on the safe side

## Safe starting lockout

The starting lockout is the most cost-effective solution for preventing the drive from restarting unintentionally. The power supply is cut off electronically.

It is implemented electronically on two channels. The starting lockout is activated via two redundant 24 V signals.

This function can be selected with all control units except BASIC OPEN LOOP.

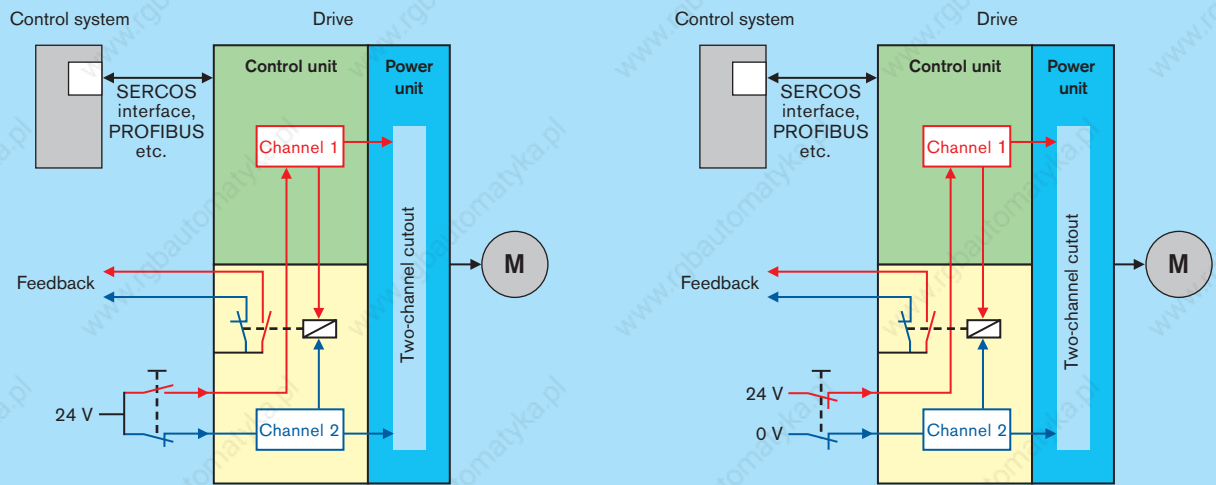

Starting lockout selected via NC/NO contacts or via two NC contacts

## Safe stop and safe motion

The ADVANCED and BASIC UNIVERSAL dual-axis control units offer you all the available safety functions – including safe motion and safe absolute position.

This safety is guaranteed by two redundant, diverse processor systems which carry out all the relevant calculations separately and monitor each other.

The two-channel selection of the required safety function can be executed differently.

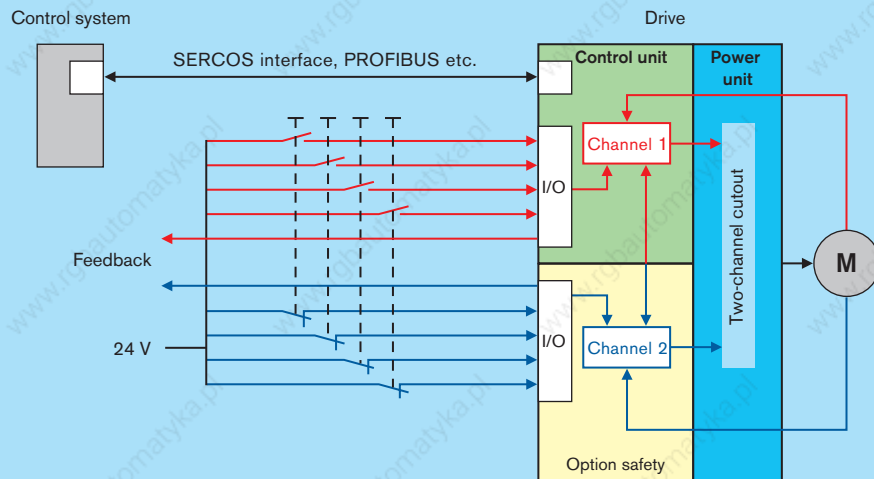

Selection and feedback via 24 V signals – the simplest way.

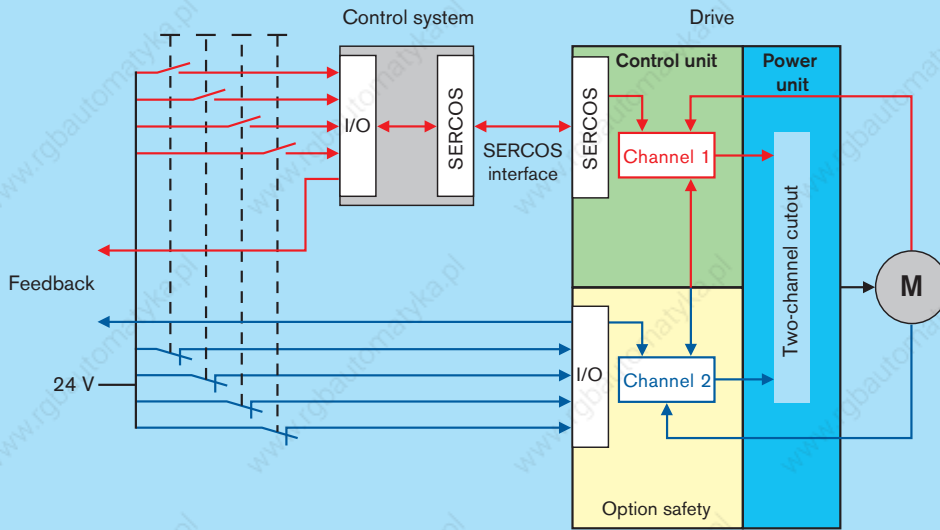

Selection and feedback signal via control communication (channel 1) and 24 V signals (channel 2) – for simpler wiring

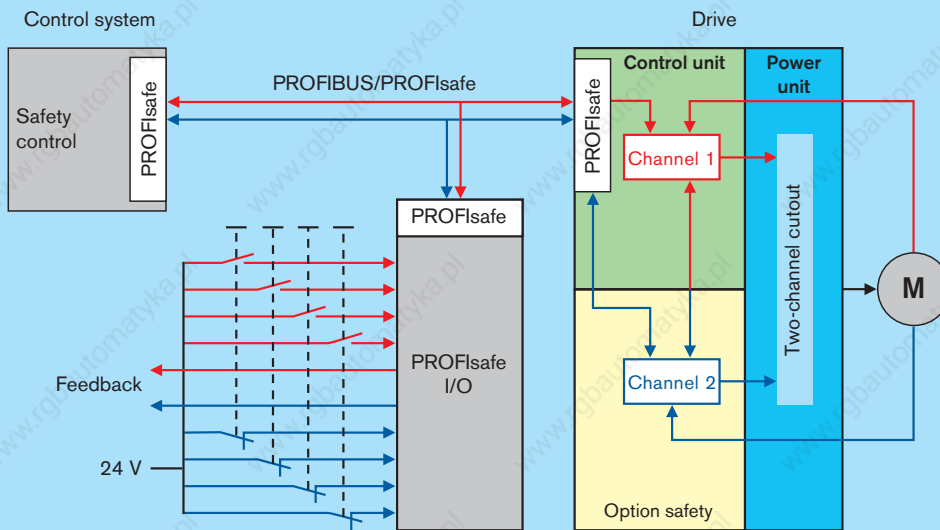

Selection and feedback signal via PROFIsafe – the user-friendly solution

# Rexroth IndraWorks – a tool for all engineering tasks

Simple and user-friendly, Rexroth IndraWorks is the ideal engineering environment for all Rexroth electrical control and drive systems. This engineering framework brings together in one integrated interface all the tools required for:

- Configuration
- Programming
- Parameterization
- Operation
- Visualization
- Diagnostics

## Advantages

- Integrated software framework for all engineering tasks
- Application-oriented tools
- Intelligent user guidance
- User-friendly, menu-driven operation
- Standardized programming according to IEC 61131-3
- PLCopen-compliant module library
- Open-architecture through integrated FDT/DTM technology
- Microsoft .NET technology

IndraWorks D for IndraDrive can be supplied on CD-ROM

- Order number:  
SWA-IWORKS-D\*\*-xxVRS-D0-CD650-COPY

or combined with the cam editor, CamBuilder

- Order number:  
SWA-IWORKS-DC\*-xxVRS-D0-CD650

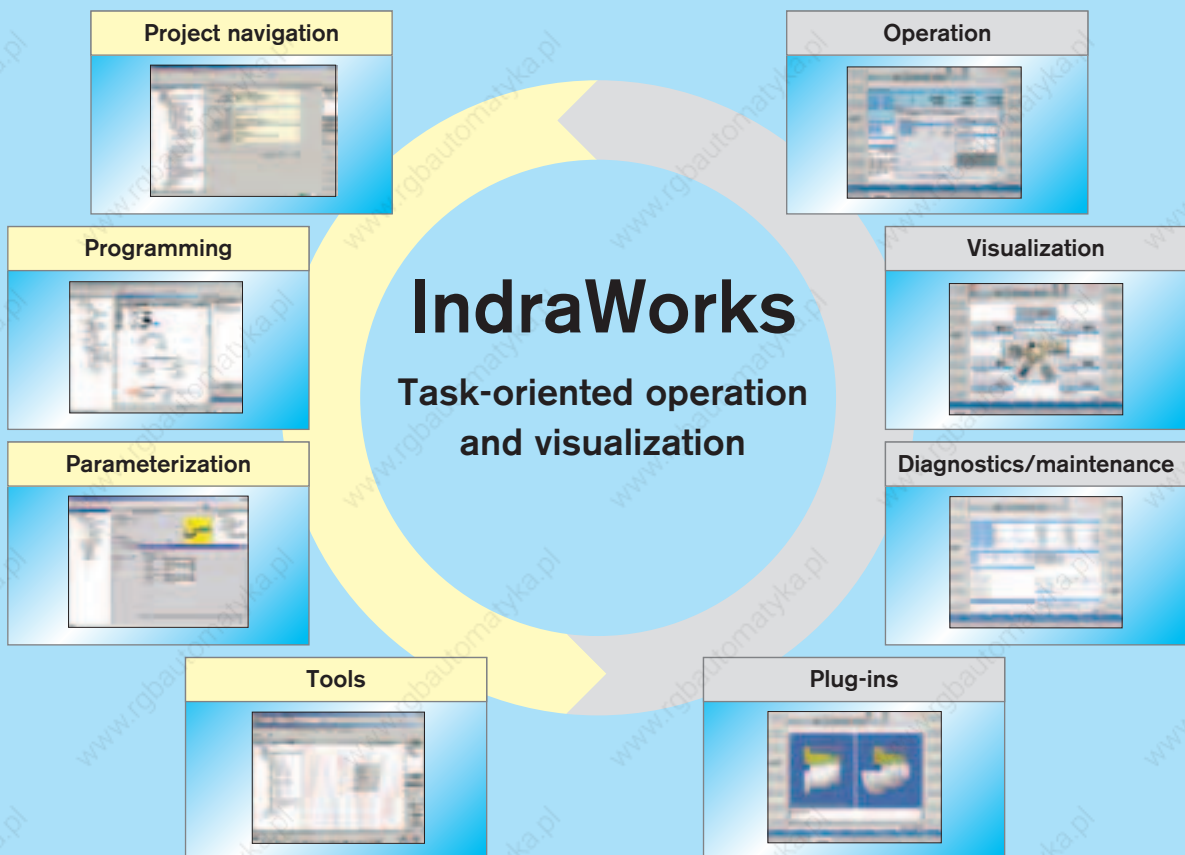

Rexroth IndraWorks – the integrated engineering framework for project planning, programming, parameterization, operation and monitoring

## IndraWorks – the universal engineering framework

- ! One tool for all automation tasks
- ! Guided start-up for rapid achievement of results
- ! Offline configuration of projects
- ! User-friendly programming environment

# Your benefits

### Start-up wizard

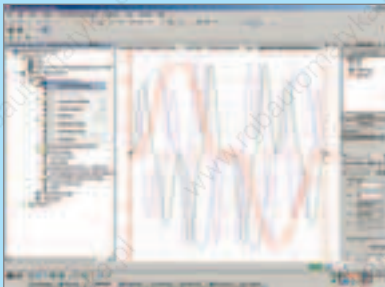

IndraWorks interactively guides you through all the steps of the startup process and only requires you to input the relevant data. All values to be input are directly related to the mechanics of the machine. This simplifies the input of data, along with allowing you to freely select measurement units.

You individually assemble the required sequence of movements from a large selection of positioning modes presented in graphic form. Once compiled, the set of parameters is saved in a file and can be easily transmitted to other machines via fieldbus or the RS232 serial interface.

### Offline mode

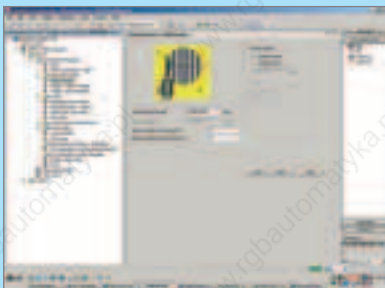

The machine-related modes of operation and the corresponding parameters can be set in advance offline and later transferred to the machine.

### Programming

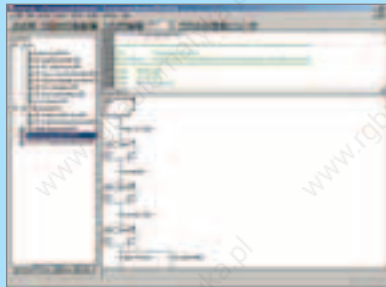

All functionality and programming modes according to IEC 61131-3 are available for the drive-integrated PLC.

With PLCopen function blocks, you can quickly and transparently integrate drive functionality into your PLC program.

### Integrated technology functions

The configurable Motion Logic-based technology functions allow you to perform the full range of different process-oriented tasks – and require no programming skills.

### Four-channel oscilloscope

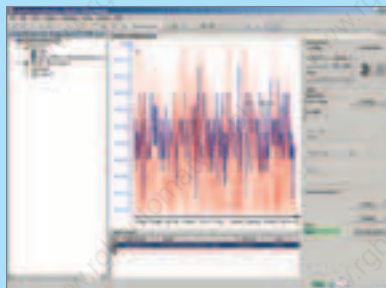

The integrated four-channel oscilloscope is available to assist with drive optimization, troubleshooting and preventive maintenance. For documentation purposes all the measurements and the related settings can be printed out or saved to a file.

### Auto-tuning



Parameters for all internal control functions are automatically set when IndraDyn motors are connected.

This setting is ideal for the majority of applications, requiring no further adjustment. Where requirements are more complex, the auto-tuning function is available to assist with adjusting the control settings to your machine.

### CamBuilder (optional)

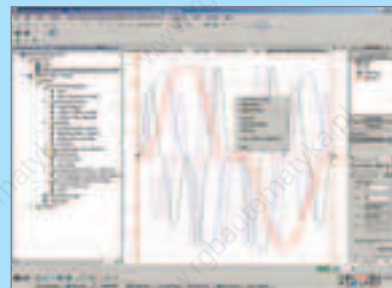

Rexroth CamBuilder is a graphics-based software tool for the convenient creation of electronic cams. With a few inputs, you can implement various applications easily and quickly. The established cams are directly transferable to Rexroth drives and controls.

# Rexroth IndraSize – rapid and safe sizing

IndraSize – the user-friendly program for drive sizing – is the quickest way to finding the optimum drive for your machine. Regardless of whether you are using a conventional servo axis or direct drive, IndraSize allows you to define the ideal motor/drive combination in a few steps.

## Mechanics

IndraSize is compatible with all standard drive mechanisms such as:

- Ball screw with rotating screw
- Ball screw with rotating nut
- Rack and pinion
- Belt drive
- Direct drive, linear
- Direct drive, rotary
- Roll feed
- Cross cutter

With the aid of graphics you simply simulate your machine kinematics, combining the motor and the selected mechanical parts with the various transfer units.

- Coupling
- Belt drive
- Gears

Any number of these can be combined in any order.



## Motion profile

With IndraSize you can freely compile a full motion profile from individual sequences of movements.

Moreover, IndraSize allows you to define typical applications very simply by inputting parameters. Applications can be configured in next to no time, such as:

- Roll feeds
- Press feeders
- Flying cutoff
- Winders
- Cross cutters

## Download

IndraSize can be downloaded from the Internet at [www.boschrexroth.com/indrasize](http://www.boschrexroth.com/indrasize)

## Mechanical system



**Ball screw with rotating screw**



**Ball screw with rotating nut**



**Belt drive**



**Gear rack and pinion**



**Direct drive, linear**



**Direct drive, rotary**



**Roller mechanics**

**and much more**

# Five steps to your drive solution

Regardless of whether you want to tackle a simple or complex drive task – whatever the case, IndraSize will lead you confidently through just five steps to success. Let the menu take you through the individual program steps from selecting the mechanical system and associated motion profile right through to the point where you are presented with the optimum motor/drive combination together with a table or curve showing its performance data.

**1. Step:**  
**Select mechanical system and motion profile**

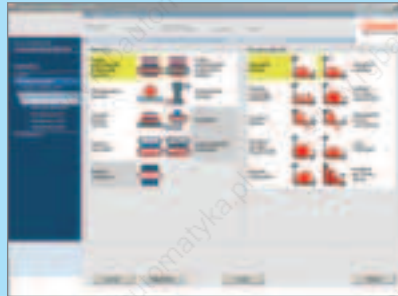

**4. Step:**  
**Select the drive from the filtered list generated**

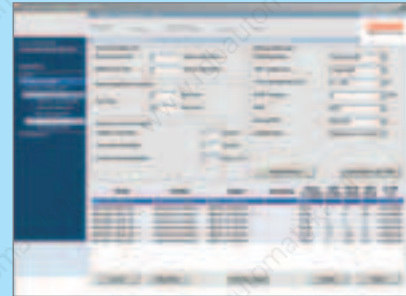

**2. Step:**  
**Input mechanical and link element data**



**5. Step:**  
**Specify the presentation of results**



**3. Step:**  
**Define the motion cycle**



# Rexroth IndraDyn – motors



Rexroth

## A powerful family

- Extensive range including robust housed and frameless (kit) motors
- Coverage of entire power range
- High-precision feedback systems
- Highly-dynamic synchronous linear motors
- Special hazardous duty designs conforming to ATEX or UL/CSA

## Your benefits

### IndraDyn S

Synchronous MSK servo motors for all requirements up to 230 Nm  
Synchronous MKE servo motors with explosion-proof enclosure for potentially explosive areas up to 190 Nm

### IndraDyn A

Air-cooled asynchronous MAD servo motors with power ratings up to 100 kW  
Liquid-cooled asynchronous MAF servo motors with power ratings up to 85 kW

### IndraDyn L

Synchronous linear motors for feeding forces of up to 21,500 N

### IndraDyn H

High-speed frameless (kit) motors for speeds of up to 30,000 rpm and maximum torques of up to 4,500 Nm

### IndraDyn T

Synchronous torque motors with torque ratings up to 13,800 Nm and speeds of up to 2,000 rpm

### Gearboxes

GTE servo planetary gears for standard applications  
GTM servo planetary gears for high-performance applications

### Standard and geared motors

Wide range of motors made by well-known manufacturers for combining with IndraDrive



# IndraDyn S – MSK servo motors to meet all requirements

The particularly outstanding features of the MSK range of motors are its wide power spectrum and narrow size increments. The high torque density of these synchronous servo motors allows a particularly compact design with maximum torques of up to 230 Nm.

Depending on the level of precision required, we can supply the motors with feedback systems for standard or high-precision requirements. Both feedback versions are available in a single-turn and multi-turn configuration.

A number of further options, such as the shaft keyway, holding brake, reduced runout and the high protection category IP65 mean that they can be used in virtually any application.



The simple step-by-step guide to ordering your MSK servo motor:

**Option**  
**MSK060C-0600-NN-S1-UG0-NNNN**

#### Motor

- Size (e. g. "060")
- Overall length (e. g. "C")
- Winding (e. g. "0600")

#### Cooling system

**NN** = Natural convection

Surface cooling or (FN)  
Option of liquid cooling for certain sizes

#### Feedback

- S1** = Single-turn encoder (HiPerface) 128 increments
- M1** = Multi-turn encoder (HiPerface) 128 increments with 4096 revolutions, absolute
- S2** = Single-turn encoder (EnDat) 2048 increments
- M2** = Multi-turn encoder (EnDat) 2048 increments with 4096 revolutions, absolute

#### Shaft

- G** = Plain shaft with shaft sealing ring
- P** = Keyway conforming to DIN 6885-1 and shaft sealing ring

#### Other versions

- N** = Standard
- S** = Hazardous duty version conforming to Equipment Group II, Category 3, G and D

#### Shaft Runout

- N** = Standard, in conjunction with S1 or M1 feedback only
- R** = Reduced, linear movement conforming to DIN 42955, in conjunction with S2 or M2 feedback only

#### Holding brake

- 0** = without holding brake
- 1** = with electr. released holding brake



## Compact and powerful

- ! Maximum torques up to 230 Nm
- ! Maximum speeds up to 9,000 rpm
- ! Feedback systems for a wide and diverse range of applications
- ! High protection category IP65
- ! Choice of cooling systems

# Your benefits

Motor	Maximum speed	Cont. torque at standstill	Maximum torque	Rated current	Maximum current	Moment of inertia	Dimensions															
							$n_{Max}$ [rpm]	$M_0$ [Nm]	$M_{Max}$ [Nm]	$I_N$ [A]	$I_{Max}$ [A]	$J_R$ [kgm <sup>2</sup> ]	A [mm]	B [mm]	C [mm]	ØD [mm]	ØE [mm]	ØF [mm]	ØG [mm]	H [mm]		
MSK030	B-0900	9,000	0.4	1.8	1.5	6.8	0.000013	54	152.5	20	9	40	63	4.5	98.5							
	C-0900	9,000	0.8	4.0	1.6	6.75	0.000030		188													
MSK040	B-0600	6,000	1.7	5.1	2.4	10.8	0.000100	82	155.5	30	14	50	95	6.6	124.5							
	C-0600	6,000	2.7	8.1	3.7	16.7	0.000140		185.5													
MSK050	B-0300	5,000	3.0	9.0	1.8	8.1	0.000280	98	173	40	19	95	115	9	134.5							
	B-0600	6,000			3.7	16.7			203													
	C-0300	5,000	5.0	15.0	3.1	14.0	0.000330															
MSK060	B-0300	6,000	5.0	15.0	3.1	14.0	0.000480	116	181	50	24	95	130	9	156							
	B-0600	6,000			6.1	27.5			226													
	C-0300	3,500	8.0	24.0	5.0	22.5	0.000800															
MSK070	C-0150	3,000	13.0	33.0	4.6	14.0	0.002910	140	238	58	32	130	165	11	202							
	C-0300	3,000			9.2	28.0			312													
	C-0450	6,000			14.0	42.0			352													
	D-0150	2,500	17.5	52.5	6.4	19.3	0.003740		268													
	D-0300	3,000			12.8	38.6			298													
	D-0450	6,000			19.3	57.9			368													
	E-0150	2,500	23.0	69.0	8.0	24.1	0.004580		192							368	60	32	130	215	11	211.5
E-0300	4,000	16.0			48.0	434																
E-0450	6,000	24.1			72.3	502																
MSK071	D-0200	4,000	17.5	66.0	7.3	32.8	0.002500	140		312	58	32	130	165	11	202						
	D-0300	4,500			9.05	41.0				352												
	D-0450	6,000			15.4	69.3				368												
	E-0200	4,000	9.97	44.9	434																	
	E-0300	4,500	23.0	84.0	13.1	59.0	0.002900		502													
MSK100	E-0450	6,000	28.0	102.0	20.0	90.1	0.019200	192	368	60	32	130	215	11	211.5							
	B-0200	4,000			15.5	69.7			434													
	B-0300	4,500			18.4	82.7			502													
	B-0400	4,500	25.2	113.1	434																	
	B-0450	4,500	28.8	129.4	502																	
MSK101	C-0200	3,500	38.0	148.0	18.8	84.9	0.027300	192	434	80	38	180	215	14	258							
	C-0300	4,000			21.9	98.6			502													
	C-0450	4,000			37.6	169.0			410													
	D-0200	2,000	48.0	187.0	13.0	58.5	0.035000		192							410	80	38	180	215	14	258
	D-0300	3,000			22.3	100.6										501						
	D-0450	6,000			41.7	188.0										410						
	E-0200	4,000	50.0	160.0	22.8	102.5	0.009320									192						
D-0300	4,500	30.6			137.9	501																
D-0450	6,000	41.7			188.0	410																
E-0200	4,000	70.0	231.0	33.6	151.3	0.013800	192	501		80	38	180	215	14	258							
E-0300	4,500			41.6	187.4			501														
E-0450	6,000	58.3	262.4	501																		

All the specifications relate to the basic version of the motor with feedback S1 and without holding brake

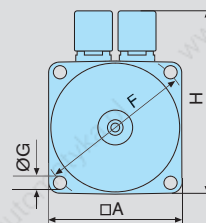
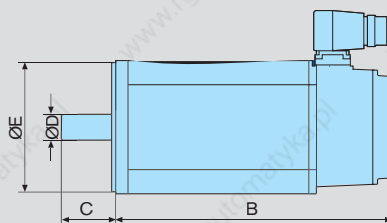
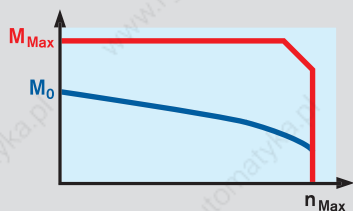

# IndraDyn S – MKE servo motors for potentially explosive areas

The MKE range of motors are specifically designed for use in production plants susceptible to explosive mixtures of air and flammable gases, vapors, mist or dust:

- Chemical industry
- Mining
- Printing shops
- Woodworking
- Paint shops
- Mills
- Food processing industry
- Refineries
- Tank farms  
and much more

Within the broad range of torques up to a maximum of 190 Nm, there is a choice of various sizes of motor with flameproof enclosures. Needless to say, all are ATEX certified and/or UL/CSA compliant.

These motors can also be supplied with a range of options – holding brake, keyway and single- or multi-turn feedback systems.



The simple step-by-step guide to ordering your MKE servo motor:

**Option**  
**MKE037B-144-AG0-BENN**

#### Motor

- Size (e. g. "037")
- Overall length (e. g. "B")
- Winding (e. g. "144")

#### Feedback

- A** = Single-turn feedback (Hiperface) 128 increments
- B**<sup>1)</sup> = Single-turn feedback (EnDat) 2048 increments
- C** = Multi-turn feedback (Hiperface) 128 increments with 4096 revolutions, absolute
- D**<sup>1)</sup> = Multi-turn feedback (EnDat) 2048 increments with 4096 revolutions, absolute

<sup>1)</sup> Not applicable to MKE037 and MKE047

#### Shaft

- G** = Plain shaft with shaft sealing ring
- P** = Keyway conforming to DIN 6885-1 and shaft sealing ring

#### Cable entry

- 4** = Diameter 13 – 16 mm
- 6** = Diameter 17 – 19.5 mm
- N** = Conforming to American Standard (UL)

#### Housing design

- E**<sup>2)</sup> = Conforming to European standard (ATEX)
  - U** = Conforming to American standard (UL)
- <sup>2)</sup> Version E only available with power connection option B

#### Power Connection

- A** = on the A-Side
- B** = on the B-Side
- L** = Left
- R** = Right

#### Holding brake

- 0** = without holding brake
- 1** = with electr. released holding brake



## Ultra-safe

- ! Maximum torques up to 190 Nm
- ! Maximum speeds up to 9,000 rpm
- ! Range of feedback systems
- ! Explosion-proof enclosure
- ! Compliance with ATEX and UL/CSA

# Your benefits

Motor		Maximum speed	Cont. torque at standstill	Maximum torque	Rated current	Maximum current	Moment of inertia	Dimensions							
		$n_{Max}$ [rpm]	$M_0$ [Nm]	$M_{Max}$ [Nm]	$I_N$ [A]	$I_{Max}$ [A]	$J_R$ [kgm <sup>2</sup> ]	A [mm]	B [mm]	C [mm]	ØD [mm]	ØE [mm]	ØF [mm]	ØG [mm]	H [mm]
MKE037	B-144	9,000	0.9	4	4.7	21.2	0.00003	60	283	20	9	40	70	4.5	123
MKE047	B-144	6,000	2.7	11.3	7.1	32	0.00017	88	287	30	14	50	100	6.6	146
MKE098	B-047	3,200	12.0	43.5	13.9	62.6	0.00430	144	383	50	24	110	165	11	202
	B-058	4,000		43.5	17.5	79									
MKE118	B-024	2,000	28.0	102	21.7	97.7	0.01940	194	492	60	32	130	215	14	-
	B-058	4,000			40.1	180.5									
	D-012	1,000	48.0	187	17.5	78.8	0.03620	664	60	32	130	215	14	-	
	D-027	2,000			31.3	140.9									
	D-035	3,000			42.2	190									

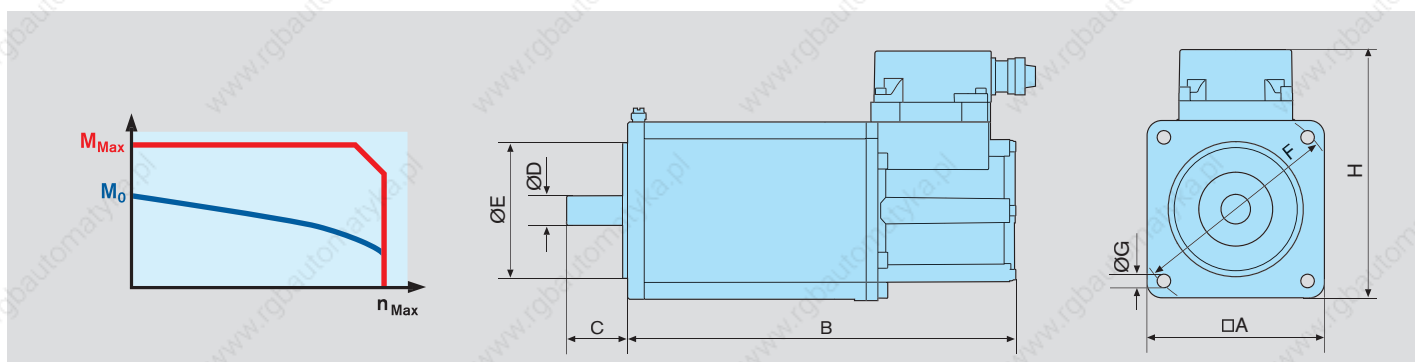

### Internationally recognized certification

MKE motors have been certified by the German metrology institute providing scientific and technical services, the PTB Braunschweig, in accordance with Directive 94/9/EC – ATEX95 (PTB 03 ATEX 1108 X  $\text{Ex}$  II 2 G/D EEx d IIB T4 IP6X T 135 °C).

The certificates are recognized by all member states of the European Union as well as non-European members of the CENELEC.



MKE motors based on the American standard (UL/CSA) conforming to Class I, Groups C and D as per UL508C, UL674 and UL1446, have been certified directly by Underwriters Laboratories Inc. (UL) in the USA.



MKE as per ATEX – terminal box with EExd cable connectors



MKE as per UL/CSA – terminal box with lines for conduit installation

# IndraDyn A – MAD asynchronous servo motors for high performance

With their phenomenal power density, the MAD range of motors is predestined for servo and main spindle applications, such as in machine tools, printing presses or metal forming technology.

High-resolution single-turn or multi-turn feedback systems and outstanding true running quality guarantee highest handling precision. In addition to the optional keyway and holding brake, these motors can also be supplied with a special bearing assembly for high-speed applications or for applications with increased radial load.

The motor protection category IP65 even includes the fan motor, making it suitable for harsh industrial use.

The easy-maintenance design of the motor means that it is even possible to exchange the fan while the motor is running – particularly advantageous in the printing industry.



The simple step-by-step guide to ordering your MAD asynchronous servo motor:

**Option**  
**MAD100C-0100-SA-S1-AH0-05-N1**

#### Motor

- Size (e. g. "100")
- Overall length (e. g. "C")
- Winding (e. g. "0100")

#### Cooling system

- SA** = Axial-flow fan
- SL** = Fan cowl

#### Transducer

- S2** = Single-turn feedback (EnDat) 2048 increments
- M2** = Multi-turn feedback (EnDat) 2048 increments with 4096 revolutions, absolute
- C0** = Incremental encoder 2048 increments

#### Line terminal

- A** = Plug for A side
- B** = Plug for B side
- L** = Plug left
- R** = Plug right
- F** = Terminal box for A side
- K** = Terminal box for B side

#### Shaft

- G** = Plain shaft with sealing ring
- H** = Plain shaft without sealing ring
- P** = With keyway and sealing ring
- Q** = With keyway but without sealing ring

#### Vibration severity grade

- 1** = R
- 2** = S
- 3** = S1

#### Bearing assembly

- N** = Standard
- H<sup>1)</sup>** = High speed
- V** = Heavy duty

<sup>1)</sup> Applies to MAD100 and MAD130 only

#### Construction

- 05** = Flange-mounted
- 35** = Flange-mounted or foot-mounted

#### Holding brake

- 0** = without holding brake
- 1** = with electr. released holding brake
- 3** = with electr. released holding brake, heavy duty
- 5** = with electr. clamped holding brake



## Robust and easy-maintenance

- Rated outputs of up to 100 kW
- Maximum speeds up to 11,000 rpm
- Feedback systems for a wide and diverse range of applications
- High protection category IP65, including fan motor
- Easy-maintenance motor design

# Your benefits

Motor	Rated speed	Maximum speed	Rated torque	Maximum torque	Rated power	Rated current	Moment of inertia	Dimensions																
	$n_N$ [rpm]	$n_{Max}$ [rpm]	$M_N$ [Nm]	$M_{Max}$ [Nm]	$P_N$ [kW]	$I_N$ [A]	$J_R$ [kgm <sup>2</sup> ]	A [mm]	B [mm]	C [mm]	ØD [mm]	ØE [mm]	ØF [mm]	ØG [mm]	H [mm]									
MAD100	B-0050	500	3,000	34	75.1	1.8	5.3	0.0190	192	462	60	32	130	215	14	260								
	B-0100	1,000	6,000	31	74.7	3.2	8.9																	
	B-0150	1,500	9,000	28	68.0	4.4	11.8																	
	B-0200	2,000	11,000	28	66.2	5.9	14.6																	
	B-0250	2,500	11,000	25	61.5	6.5	16.2																	
	C-0050	500	3,000	51	112.3	2.7	8.2																	
	C-0100	1,000	6,000	50	118.8	5.2	13.2	0.0284	192	537	60	32	130	215	14	260								
	C-0150	1,500	11,000	48	110.4	7.5	19.7																	
	C-0200	2,000	9,000	45	105.5	9.4	25.7																	
	C-0250	2,500	11,000	40	98.9	10.5	27.8																	
	D-0050	500	3,000	70	153.6	3.7	10.1																	
	D-0100	1,000	6,000	64	146.5	6.7	19.3																	
D-0150	1,500	9,000	59	140.8	9.3	25.6	0.0392	192	537	60	32	130	215	14	260									
D-0200	2,000	11,000	54	129.8	11.3	27.18																		
D-0250	2,500	11,000	50	118.7	13.1	32.42																		
B-0050	500	3,000	95	208.8	5.0	12.8										0.0840	260	640	110	42	250	300	18	338
B-0100	1,000	6,000	88	209.2	9.2	24.1																		
B-0150	1,500	9,000	80	193.5	12.6	32.3																		
B-0200	2,000	10,000	80	187.2	16.8	43.0																		
B-0250	2,500	10,000	75	176.5	19.6	47.2																		
C-0050	500	3,000	140	307.9	7.3	19.7	0.1080	260	640	110	42	250	300	18	338									
C-0100	1,000	6,000	125	307.9	13.1	36.4																		
C-0150	1,500	9,000	117	275.2	18.4	48.9																		
C-0200	2,000	10,000	110	252.9	23.0	57.0																		
C-0250	2,500	10,000	100	241.4	26.2	67.0																		
D-0050	500	3,000	180	395.6	9.4	24.2										0.1640	260	640	110	42	250	300	18	338
D-0100	1,000	6,000	170	417.8	17.8	43.7																		
D-0150	1,500	9,000	155	374.6	24.3	61.5																		
D-0200	2,000	10,000	150	340.7	31.4	71.3																		
D-0250	2,500	10,000	120	310.0	31.4	72.0																		
B-0050	500	3,000	220	483.9	11.5	26.08	0.2500	316	748	110	55	300	350	18	393									
B-0100	1,000	6,000	200	460.9	20.9	43.5																		
B-0150	1,500	6,000	190	440.1	29.9	61.6																		
B-0200	2,000	6,000	160	375.3	33.5	75.8																		
C-0050	500	3,000	240	528.2	12.6	27.6										0.3110	316	748	110	55	300	350	18	393
C-0100	1,000	6,000	225	527.2	23.6	52.6																		
C-0150	1,500	6,000	215	496.0	33.8	75.3																		
C-0200	2,000	6,000	210	494.2	44.0	93.9																		
C-0250	2,500	6,000	325	715.5	17.0	38.2																		
C-0100	1,000	6,000	300	665.0	31.4	77.4	0.4580	320	979	140	60	300	350	18	449									
C-0150	1,500	6,000	270	665.0	42.4	108.2																		
C-0200	2,000	6,000	250	594.4	52.4	104.6																		
D-0050	500	3,000	390	857.8	20.4	39.7										0.5940	320	979	140	60	300	350	18	449
D-0100	1,000	6,000	370	901.5	38.7	82.4																		
D-0150	1,500	6,000	340	792.9	53.4	107.8																		
D-0200	2,000	6,000	300	768.2	62.8	117.4																		

All the specifications given relate to the basic version of the motor without a holding brake. The maximum speed depends on the bearing version.

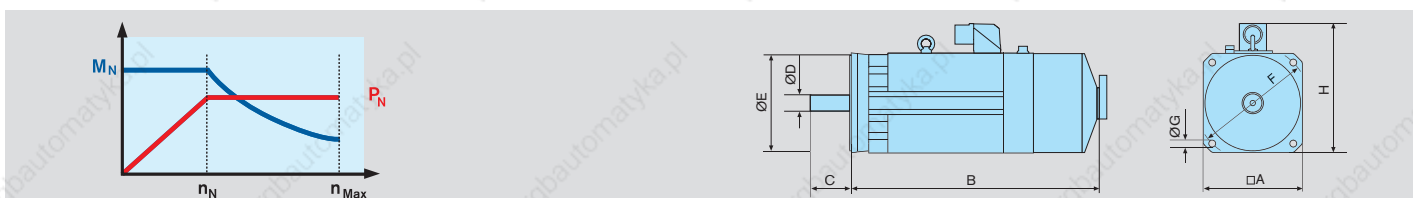

# IndraDyn A – MAF asynchronous servo motors with liquid cooling

The liquid-cooled motors in the MAF series are particularly suitable for applications demanding maximum torques in minimum amounts of space. At the same time the unique cooling system design ensures the thermal isolation of motor and machine and therefore maximum handling precision. The quick couplings with integrated leak-proofing simplify your maintenance work.

Options such as holding brakes, different feedback systems, vibration severity grades and shaft specifications allow you to tailor the MAF motors optimally to your specific application.



The simple step-by-step guide to ordering your MAF asynchronous servo motor:

**Option**  
**MAF100C-0100-FQ-S1-AH0-05-N1**

#### Motor

- Size (e. g. "100")
- Overall length (e. g. "C")
- Winding (e. g. "0100")

#### Cooling system connection

- FQ** = Connection thread
- FR** = Quick coupling

#### Transducer

- S2** = Single-turn feedback (EnDat) 2048 increments
- M2** = Multi-turn feedback (EnDat) 2048 increments with 4096 revolutions, absolute
- CO** = Incremental encoder, 2048 increments

#### Line terminal

- A** = Plug for A side
- B** = Plug for B side
- L** = Plug left
- R** = Plug right
- F** = Terminal box for A side
- K** = Terminal box for B side

#### Shaft

- G** = Plain shaft with sealing ring
- H** = Plain shaft without sealing ring
- P** = With keyway and sealing ring
- Q** = With keyway but without sealing ring

#### Vibration severity grade

- 1** = R
- 2** = S
- 3** = S1

#### Bearing assembly

- N** = Standard
- H<sup>n</sup>** = High speed
- V** = Heavy duty

<sup>1)</sup> Applies to MAF100 and MAF130 only

#### Construction

- 05** = Flange-mounted
- 35** = Flange-mounted or foot-mounted

#### Holding brake

- 0** = without holding brake
- 1** = with electr. released holding brake
- 3** = with electr. released holding brake, heavy duty
- 5** = with electr. clamped holding brake



## Compact and powerful

- ▮ Rated outputs of up to 85 kW
- ▮ Maximum speeds up to 11,000 rpm
- ▮ Feedback systems for a wide and diverse range of applications
- ▮ High protection category IP65
- ▮ Liquid cooling with quick coupling

# Your benefits

Motor	Rated speed $n_N$ [rpm]	Maximum speed $n_{Max}$ [rpm]	Rated torque $M_N$ [Nm]	Maximum torque $M_{Max}$ [Nm]	Rated power $P_N$ [kW]	Rated current $I_N$ [A]	Moment of inertia $J_R$ [kgm <sup>2</sup> ]	Dimensions								
								A [mm]	B [mm]	C [mm]	ØD [mm]	ØE [mm]	ØF [mm]	ØG [mm]	H [mm]	
MAF100	B-0050	500	3,000	50	109.7	2.6	8.5	0.0190	192	382	60	38	130	215	14	260
	B-0100	1,000	6,000	46	110.2	4.8	14.3									
	B-0150	1,500	9,000	42	101.4	6.6	18.1									
	B-0200	2,000	11,000	38	92.4	8.0	23.9									
	B-0250	2,500	11,000	33	83.6	8.64	26.0									
	C-0050	500	3,000	70	153.7	3.9	12.1	0.0284	192	457	60	38	130	215	14	260
	C-0100	1,000	6,000	68	154.0	7.5	19.0									
	C-0150	1,500	9,000	66	149.5	10.4	27.9									
	C-0200	2,000	11,000	64	145.2	13.4	36.7									
	C-0250	2,500	11,000	62	138.1	16.23	40.2									
	D-0050	500	3,000	88	193.3	4.6	14.5	0.0320	192	532	60	38	130	215	14	260
	D-0100	1,000	6,000	84	194.0	8.8	25.1									
D-0150	1,500	9,000	79	185.3	12.4	32.7										
D-0200	2,000	9,000	80	182.3	16.8	43.1										
D-0250	2,500	9,000	75	177.5	19.63	45.8										
MAF130	B-0050	500	3,000	116	254.7	6.1	14.7	0.0790	260	408	110	42	250	300	18	338
	B-0100	1,000	6,000	112	254.7	11.7	28.4									
	B-0150	1,500	9,000	115	264.0	18.1	43.7									
	B-0200	2,000	10,000	100	237.9	20.9	51.7									
	B-0250	2,500	10,000	90	220.9	23.56	55.5									
	C-0050	500	3,000	155	340.0	8.1	21.0	0.1010	260	478	110	42	250	300	18	338
	C-0100	1,000	6,000	150	340.2	15.7	38.0									
	C-0150	1,500	9,000	145	329.8	22.8	53.2									
	C-0200	2,000	10,000	135	314.7	28.3	69.8									
	C-0250	2,500	10,000	125	298.4	32.72	75.5									
	D-0050	500	3,000	230	506.3	12.0	32.3	0.1510	260	608	110	42	250	300	18	338
	D-0100	1,000	6,000	220	505.7	23.0	52.0									
D-0150	1,500	9,000	200	484.4	31.4	72.6										
D-0200	2,000	10,000	200	461.4	41.9	93.9										
D-0250	2,500	10,000	190	432.1	49.74	113.0										
MAF160	B-0050	500	3,000	270	594.5	14.1	34.25	0.2300	316	618	110	60	300	350	18	393
	B-0100	1,000	6,000	260	592.7	27.2	73.7									
	B-0150	1,500	6,000	250	570.8	39.3	89.5									
	B-0200	2,000	6,000	240	550.1	50.3	108.5									
	C-0050	500	3,000	340	747.8	17.8	47.4	0.2600	316	708	110	60	300	350	18	393
	C-0100	1,000	6,000	325	746.4	34.0	91.2									
	C-0150	1,500	6,000	300	681.4	47.1	109.5									
	C-0200	2,000	6,000	285	677.4	59.7	136.0									
MAF180	C-0050	500	3,000	435	986.2	22.8	50.0	0.4900	320	792	140	60	300	350	18	449
	C-0100	1,000	6,000	390	956.7	40.84	90.7									
	C-0150	1,500	6,000	365	858.1	57.33	128.8									
	C-0200	2,000	6,000	318	739.2	66.6	154.0									
	D-0050	500	3,000	500	1100.2	26.2	60.4	0.6100	320	902	140	60	300	350	18	449
	D-0100	1,000	6,000	460	1094.5	48.17	94.8									
	D-0150	1,500	6,000	435	1013.4	68.33	135.5									
	D-0200	2,000	6,000	400	1008.0	83.8	168.5									

All the specifications given relate to the basic version of the motor without a holding brake. The maximum speed depends on the bearing version.

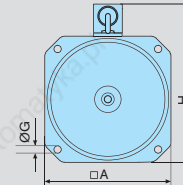
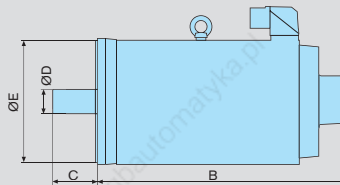
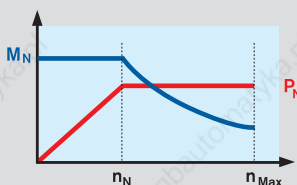

# IndraDyn L – linear motors for maximum dynamics

Compact construction, high dynamics and maximum forces of up to 21,500 N – these are the challenges to which our IndraDyn L synchronous linear motors are admirably equipped to meet. Given their exceptionally low force ripple, these motors are particularly suitable for applications with maximum demands in terms of acceleration and accuracy.

There is a choice of sizes geared to typical requirements supplied in standard encapsulation or thermal encapsulation for maximum temperature stability.

The combination of several linear motors – whether in series or parallel – gives rise to completely new machine concepts with greatly enhanced machining force.



The simple step-by-step guide to ordering your IndraDyn L synchronous linear motor:

## Primary part

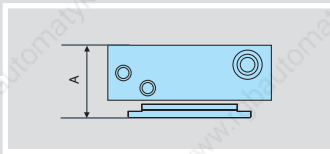
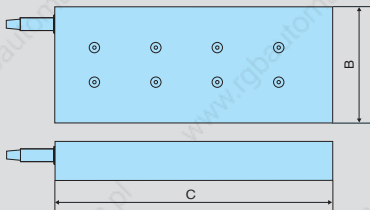

**MLP140C-0170-FS-N0CN-NNNN**

Option

### Enclosure

- S** = Standard encapsulation
- T** = Thermal encapsulation

### Motor (primary part)

- Size (e. g. "140")
- Overall length (e. g. "C")
- Winding (e. g. "0170")

## Secondary part

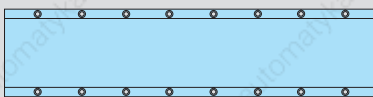

**MLS140S-3A-0150-NNNN**

Option

### Segment length

- 0150** = 150 mm
- 0450** = 450 mm
- 0600** = 600 mm

### Motor (secondary part)

- Size (e. g. "140")

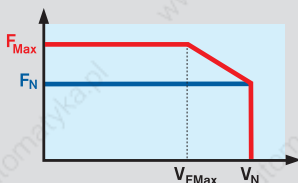



## High dynamics and precision

- ! Maximum forces of up to 21,500 N
- ! Maximum speeds up to 600 m/min
- ! Compact design
- ! Low force ripple
- ! Heat dissipation minimized by thermal encapsulation

# Your benefits

Motor		Nominal continuous force	Maximum force	Nominal speed	Maximum speed at F	Rated current	Maximum current	Standard encapsulation				Thermal encapsulation			
								Total installation height	Primary part width	Primary part length	Primary part mass	Total installation height	Primary part width	Primary part length	Primary part mass
								A [mm]	B [mm]	C [mm]	mp [kg]	A [mm]	B [mm]	C [mm]	mp [kg]
MLP040	A-0300	250	800	500	300	4.2	20	61.4	100	210	4.7	73.9	108	235	6.1
	B-0150	370	1,150	300	150	4.2	20								
	B-0250	370	1,150	400	250	5.3	27								
	B-0300	370	1,150	500	300	6	35								
MLP070	A-0150	550	2,000	200	150	5.5	36	61.4	130	285	8.4	73.9	138	385	13.4
	A-0220	550	2,000	360	220	6.3	35								
	A-0300	550	2,000	450	300	10.5	55								
	B-0100	820	2,600	200	100	5.5	28								
	B-0120	820	2,600	220	120	5.8	42								
	B-0150	820	2,600	260	150	6.2	48								
	B-0250	820	2,600	400	250	10	55								
	B-0300	820	2,600	450	300	12	70								
	C-0120	1,200	3,800	180	120	8.9	55								
	C-0150	1,200	3,800	250	150	10	62								
	C-0240	1,200	3,800	350	240	13	70								
	C-0300	1,200	3,800	450	300	19	110								
MLP100	A-0090	1,180	3,750	150	90	6.6	38	61.4	160	360	13.5	73.9	168	385	17
	A-0120	1,180	3,750	190	120	8	44								
	A-0150	1,180	3,750	220	150	10	55								
	A-0190	1,180	3,750	290	190	12	7								
	B-0120	1,785	5,600	190	120	12	70								
	B-0250	1,785	5,600	350	250	22	130								
	C-0090	2,310	7,150	170	90	13	90								
	C-0120	2,310	7,150	190	120	15	85								
MLP140	C-0190	2,310	7,150	290	190	23	140	61.4	200	360	17	73.9	208	385	21.2
	A-0120	1,680	5,200	190	120	12	70								
	B-0090	2,415	7,650	160	90	13	70								
	B-0120	2,415	7,650	190	120	18	105								
	C-0050	3,150	10,000	110	50	13	70								
MLP200	C-0120	3,150	10,000	190	120	21	125	61.4	200	510	24.5	73.9	268	535	30.1
	C-0170	3,150	10,000	250	170	29	140								
	A-0090	2,415	7,450	170	90	13	70								
	A-0120	2,415	7,450	190	120	16	88								
	B-0040	3,465	10,900	100	40	13	70								
	B-0120	3,465	10,900	190	120	22	130								
	C-0090	4,460	14,250	170	90	23.3	120								
	C-0120	4,460	14,250	190	120	30	175								
	C-0170	4,460	14,250	220	170	46	210								
	D-0060	5,560	17,750	140	60	28	140								
MLP300	D-0100	5,560	17,750	180	100	46	210	61.4	200	810	51	73.9	368	535	58.3
	D-0120	5,560	17,750	190	120	53	225								
	A-0090	3,350	11,000	160	90	19	110								
	A-0120	3,350	11,000	190	120	23	138								
	B-0070	5,150	16,300	140	70	28	140								
	B-0120	5,150	16,300	190	120	35	205								
MLP300	C-0060	6,720	21,500	110	60	29	140	61.4	200	-	-	77.9	368	685	74.9
	C-0090	6,720	21,500	150	90	37	212								

All the specifications given are based on operation with liquid cooling and 540 V DC bus voltage

# IndraDyn H – high-speed frameless (kit) motors

The liquid-cooled high-speed IndraDyn H kit motors achieve maximum torques of up to 4,500 Nm with speeds of up to 30,000 rpm.

With their broad constant output power range, short ramp-up time and low rotor temperature they are predestined for motor spindles and other similar areas of application.

The new onboard cooling system simplifies their integration in the machine and increases their cooling efficiency.

For extra easy assembly and disassembly we can supply the rotor on request with a step interference fit and the corresponding hydraulic connections.



The simple step-by-step guide to ordering your high-speed IndraDyn H motor:

## Stator

Option  
MSS182A-0100-FA-N0CN-NNNN

### Motor (Stator)

- Size (e. g. "182")
- Overall length (e. g. "A")
- Winding (e. g. "0100")

## Rotor

Option  
MRS182A-1N-0075-NNNN

### Internal diameter of rotor

Corresponding internal diameters are available for every rotor size. For further details see configuration handbook.

### Motor (Rotor)

- Size (e. g. "182")
- Overall length (e. g. "A")

### Rotor version

- 1N = Smooth bore
- 2N = Step interference fit with hydraulic connection

## High dynamics and precision

- Maximum torques up to 4,500 Nm
- Maximum speeds up to 30,000 rpm
- Wide constant output power range
- Integrated cooling system
- Straightforward integration in the machine

# Your benefits

Motor		Rated speed	Maximum speed	Rated torque	Maximum torque	Rated power	Rated current	Maximum current	Rotor <sup>1)</sup> moment of inertia	Dimensions			
		$n_N$ [rpm]	$n_{Max}$ [rpm]	$M_N$ [Nm]	$M_{Max}$ [Nm]	$P_N$ [kW]	$I_N$ [A]	$I_{Max}$ [A]	$J_R$ [kgm <sup>2</sup> ]	$\varnothing A$ [mm]	B [mm]	$\varnothing C$ <sup>1)</sup> [mm]	
MSS102	B-0800	8,000	30,000	12	30	10	18	48	0.0030	120	160	46	
	D-0800	8,000	30,000	20	45	17	24	69	0.0040		210		
	F-0800	8,000	30,000	33	75	28	39	100	0.0060		310		
MSS142	B-0700	7,000	28,000	35	80	26	38	100	0.0110	160	185	58	
	D-0700	7,000	28,000	50	115	37	55	145	0.0140		235		
	F-0700	7,000	28,000	65	150	48	68	180	0.0170		285		
MSS162	B-0400	4,000	20,000	50	115	21	42	110	0.0140	180	206	68	
	D-0400	4,000	20,000	70	160	29	64	170	0.0180		256		
	F-0310	3,100	15,500	90	200	29	64	170	0.0220		306		
	J-0200	2,000	10,000	120	275	25	64	170	0.0280		381		
MSS182	A-0100	1,000	6,000	12	30	1.25	4	11	0.0089	200	85	85	
	A-0250	2,500	12,000	12	30	3	11	32					
	B-0280	2,800	12,000	100	230	29	64	170			0.0310		235
	D-0260	2,600	12,000	140	320	38	71	200			0.0390		285
	F-0200	2,000	12,000	200	450	42	71	200			0.0530		385
MSS202	A-0200	2,000	11,000	105	270	22	45	130	0.0640	220	215	96	
	B-0150	1,500	8,200	140	390	22	52	141					
	B-0210	2,100	11,500	140	390	31	68	180					
	D-0170	1,700	9,300	175	480	31	68	180			0.0770		315
	F-0120	1,200	6,600	245	650	31	68	180			0.1040		415
MSS242	B-0100	1,000	6,000	250	575	26	68	180	0.1190	270	265	110	
	D-0070	700	4,200	375	860	28	50	180	0.1670		365		
	F-0060	600	3,600	425	970	27	68	180	0.1930		415		
MSS272	B-0065	650	3,000	400	900	27	71	200	0.2680	300	315	135	
	D-0050	500	2,200	525	1,200	28	71	200	0.3350		390		
	F-0040	400	1,800	650	1,500	27	71	200	0.4030		465		
MSS312	B-0035	350	1,500	650	1,550	24	62	180	0.6170	340	380	170	
	D-0028	280	1,200	820	1,950	24	60	160	0.7510		455		
	F-0028	280	1,200	975	2,275	29	62	180	0.8850		530		
	H-0025	250	1,100	1,125	2,750	30	62	180	1.0640		630		
	H-0085	850	3,400	1,100	2,750	98	197	570					
MSS382	B-0025	250	1,000	1,375	2,875	36	85	250	1.5250	405	430	240	
	D-0020	200	800	1,775	3,700	37	85	250	1.9110		530		
	F-0018	180	720	2,170	4,500	41	84	250	2.2960		630		

All the specifications given are based on operation with liquid cooling and 540 V DC bus voltage <sup>1)</sup> Depends on rotor version

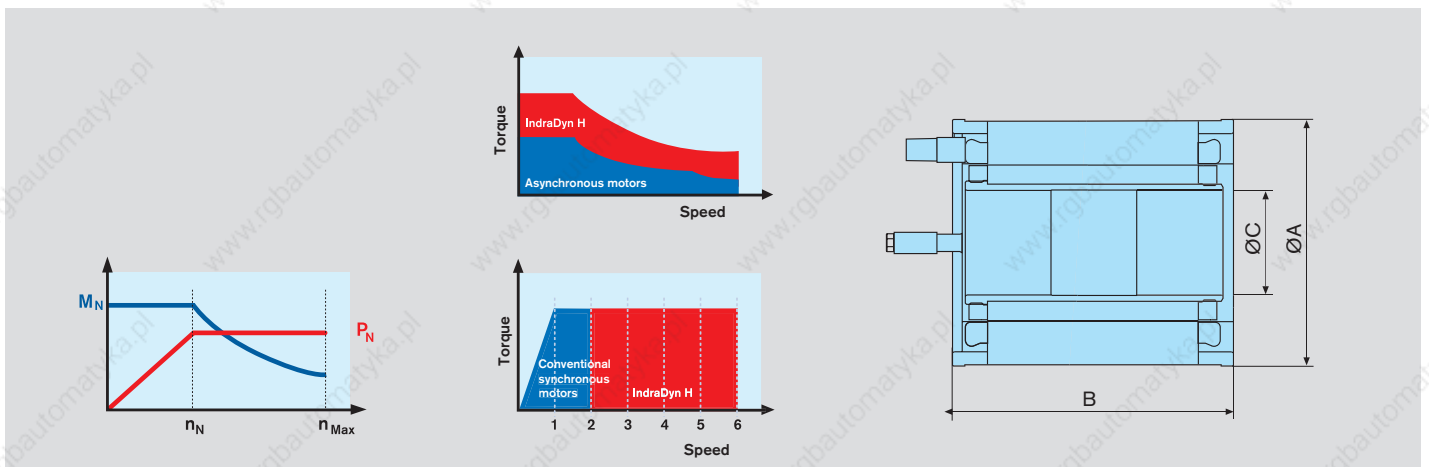

# IndraDyn T – frameless (kit) torque motors

The IndraDyn T torque motors are liquid-cooled kit motors which have been optimized for high torques of up to 13,800 Nm. They consist of a stator with three-phase winding and a rotor with permanent magnets.

Typical areas of application for these motors mainly include direct drives in rotary tables or swivel axes in machining centers. However, they also offer innovative new approaches to solutions in mechanical engineering applications using robots, plastics processing machines, woodworking machines, lathes and special purpose machines.

We can supply the motors with an optional preassembled assembly aid for quick and easy installation.



The simple step-by-step guide to ordering your IndraDyn T torque motor:

## Stator

Option  
MST530B-0070-FT-N0CN-NNNN

### Motor (Stator)

- Size (e. g. "530")
- Overall length (e. g. "B")
- Winding (e. g. "0070")

### Electrical connection

- CN = Axial on side with larger Ø
- SN = Axial on side with smaller Ø
- RN = Radial on side with larger Ø

## Rotor

Option  
MRT530B-3A-0410-NNNN

### Motor (Rotor)

- Size (e. g. "530")
- Overall length (e. g. "B")

### Internal diameter of rotor

The rotors can be supplied with different internal diameters.



## Powerful and direct

- Maximum torques of up to 13,800 Nm
- Full torque even at standstill
- Extremely high overload capacity
- Liquid cooling with thermal encapsulation
- Easy to assemble

# Your benefits

Motor	Rated torque	Maximum torque	Speed at $M_{Max}$	Rated speed	Rated current	Maximum current	Rotor <sup>1)</sup> moment of inertia	Dimensions			
								$M_N$ [Nm]	$M_{Max}$ [Nm]	$n_{MMmax}$ [rpm]	$n_N$ [rpm]
MST130	A-0200	9	15	900	2,000	7.5	16	0.0008	150	63	60
	C-0050	25	40	225	500	7.5	12	0.0018		103	
	E-0020	42	65	90	200	7.5	12	0.0029		143	
MST160	A-0050	35	90	225	500	6.5	20	0.0059	180	95	80
	C-0050	70	180	225	500	13	40	0.0108		145	
	E-0050	105	270	225	500	19.5	60	0.0158		195	
MST210	A-0027	50	100	122	270	7	25	0.0120	230	75	120
	C-0027	120	250	122	270	13	50	0.0230		120	
	D-0070			150	300	315	700			32	
	E-0027	240	500	122	270	24	90	0.0420		195	
MST290	B-0018	220	460	81	180	14.8	60	0.0800	310	105	200
	D-0002	350	700	11	25	6.3	25	0.1100		135	
	D-0004			20	45	10.4	30				
	D-0018			81	180	26	100				
	E-0004	575	1,150	18	40	12.5	50	0.1700		195	
	E-0018			81	180	35	125				
MST360	B-0018	375	900	81	180	20	70	0.1900	385	120	260
	D-0012	525	1,150	54	120	16.5	60	0.2700		150	
	D-0018			81	180	28	100				
	E-0018	875	1,900	81	180	42	141	0.4400		210	
MST450	B-0012	540	1,200	54	120	22	70	0.4500	480	120	350
	D-0006	810	1,800	27	60	18.8	50	0.6400		150	
	D-0012			54	120	33	100				
	E-0006	1,400	3,250	27	60	32	88	1.0100		210	
	E-0012			54	120	46	125				
MST530	B-0010	800	1,800	45	100	28.6	71	0.9200	565	120	410
	C-0010	1,200	2,700	45	100	31.2	88	1.2500		150	
	E-0010	2,100	4,700	45	100	64	212	1.9200		210	
	G-0007	4,200	9,200	32	70	96	305	3.8400		370	
	L-0006	6,300	13,800	27	60	120	380	5.7600		520	

All the specifications given are based on operation with liquid cooling and 540 V DC bus voltage <sup>1)</sup> Depends on rotor version

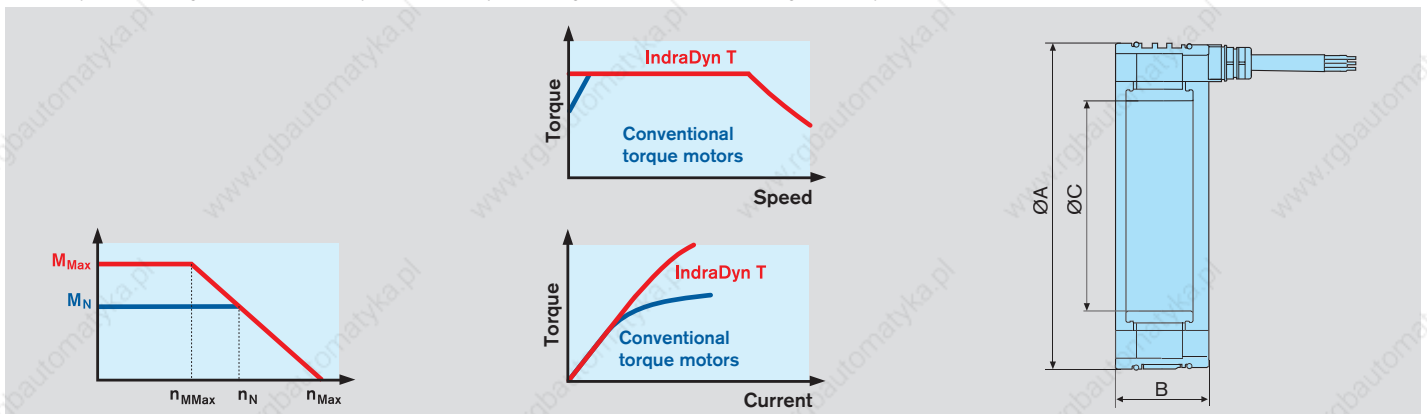

# GTE – planetary gearboxes for standard applications

Together with our dynamic MSK motors, the compact GTE range of planetary gearboxes guarantees high torques in all standard applications.

Typical areas of application include simple handling and automation systems with rack-and-pinion drives or synchronous belt drives.

Virtually all performance requirements can be met in these applications thanks to the subtle staggering of sizes and the high power density of the GTE gearboxes.

The single-stage or two-stage gearboxes can be supplied with a plain shaft or keyway.



The simple step-by-step guide to ordering your GTE planetary gearboxes:

Option  
**GTE060-NN1-004A-NN03**

#### Gearbox

- Size (e. g. "040")

#### Gear stages

- 1 = Single-stage
- 2 = Two-stage

#### Output shaft and backlash

- A = With keyway
- B = Plain shaft

#### Motor/gearboxes combination

	Motor	GTE060	GTE080	GTE120	GTE160
MSK	030	NN02	NN02	–	–
	040	–	NN03	NN03	–
	050	–	–	NN20	NN20
	060	–	–	NN21 <sup>1)</sup>	NN21
	070	–	–	–	NN16
	071	–	–	–	NN16

<sup>1)</sup> Combination only possible with single-stage gearboxes

## Economical and compact

- ! Ideal for standard applications
- ! Low backlash
- ! Open choice of mounting positions
- ! Silent operation
- ! Lifetime lubrication

# Your benefits

Gearbox	Transmission ratio		Nominal input speed	Maximum input speed	Maximum output speed	Nominal input torque	Nominal output torque	Maximum input torque	Maximum output torque	Backlash	Torsional stiffness	Efficiency	Moment of inertia	Mass						
	i		n <sub>IN N</sub> [rpm]	n <sub>IN Max</sub> [rpm]	n <sub>OUT Max</sub> [rpm]	M <sub>IN N</sub> [Nm]	M <sub>OUT N</sub> [Nm]	M <sub>IN Max</sub> [Nm]	M <sub>OUT Max</sub> [Nm]	- [arcmin]	D [Nm/arcmin]	η [%]	J [kgcm <sup>2</sup> ]	m [kg]						
GTE060	single-stage	3	4,000	13,000	4,333	4	12	4	12	< 20	1.5	96	0.135	0.9						
		4	4,000	13,000	3,250	4	16	4	16											
		5	4,000	13,000	2,600	3.2	16	3.2	16											
		8	4,000	13,000	1,625	1.9	15	1.9	15											
	two-stage	12	4,000	13,000	1,083	3.7	44	3.7	44	< 25	1.5	94	0.127	1.1						
		20	4,000	13,000	650	2.2	44	2.2	44											
GTE080	single-stage	3	4,000	7,000	2,333	13.3	40	13.3	40	< 12	4.5	96	0.770	2.1						
		4	4,000	7,000	1,750	12.5	50	12.5	50											
		5	4,000	7,000	1,400	10	50	10	50											
		8	4,000	7,000	875	6.3	50	6.3	50											
	two-stage	12	4,000	7,000	583	10	120	10	120	< 17	5.2	94	0.720	2.6						
		20	4,000	7,000	350	6	120	6	120											
		40	4,000	7,000	175	2.8	110	2.8	110											
		GTE120	single-stage	3	3,500	6,500	2,167	26.7	80				26.7		80	< 8	11	96	2.630	6
				4	3,500	6,500	1,625	25	100				25		100					
				5	3,500	6,500	1,300	22	110				22		110					
8	3,500			6,500	813	15	120	15	120											
two-stage	12	3,500	6,500	542	21.7	260	21.7	260	< 12	11	94	2.560	8							
	20	3,500	6,500	325	13	260	13	260												
	40	3,500	6,500	163	5.8	230	5.8	230												
	GTE160	single-stage	3	3,000	6,500	2,167	133.3	400				133.3		400	< 6	32.5	96	12.140	18	
4			3,000	6,500	1,625	112.5	450	112.5	450											
5			3,000	6,500	1,300	90	450	90	450											
8			3,000	6,500	813	56.3	450	56.3	450											
two-stage		12	3,000	6,500	542	66.7	800	66.7	800	< 10	35	94	12.370	22						
		20	3,000	6,500	325	40	800	40	800											
		40	3,000	6,500	163	17.5	700	17.5	700											

# GTM – planetary gearboxes for maximum performance

Characterized by a particularly high power density and low backlash, the high-precision GTM range of planetary gearboxes has been designed for mounting directly on servo motors.

Their high degree of efficiency makes these gearboxes suitable for the S1 continuous operation and therefore ideal for use in printing presses, for example.

Combined with the dynamic IndraDyn motors they achieve the highest speeds, acceleration and optimum positioning accuracy.

The single-stage or two-stage gearboxes can be supplied with a plain shaft or keyway and also with reduced backlash on request.

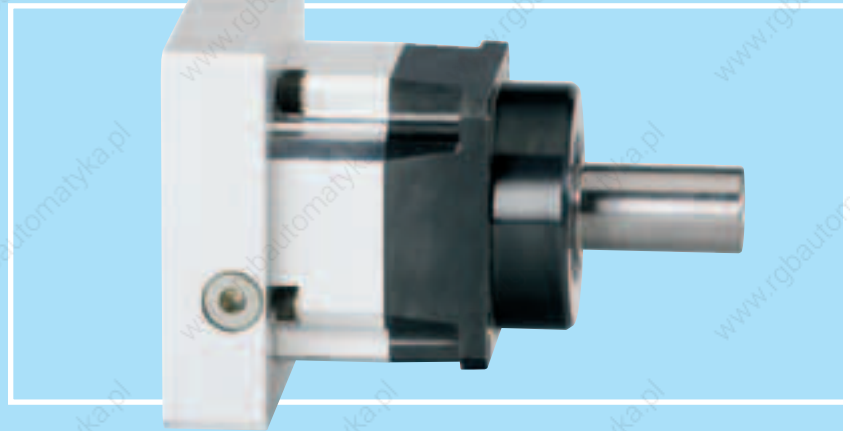

The simple step-by-step guide to ordering your GTM planetary gearbox:

Option

**GTM075-NN1-004A-NN03**

#### Gears

- Size (e. g. "075")

#### Gear range

- 1** = Single-stage
- 2** = Two-stage

#### Output shaft and backlash

- A** = With keyway
- B** = Plain shaft
- C** = With keyway and reduced backlash
- D** = Plain shaft, reduced backlash

#### Motor/gearbox combination

		Motor	GTM060	GTM075	GTM100	GTM140	GTM180	GTM240
MSK	030	NN02	–	–	–	–	–	
	040	NN03	NN03	–	–	–	–	
	050	–	NN20	NN20	NN20	–	–	
	060	–	NN21	NN21	NN21	–	–	
	070	–	–	NN16	NN16	NN16	–	
	071	–	–	NN16	NN16	NN16	–	
	100	–	–	–	NN09	NN09	–	
	101	–	–	–	NN19	NN19	–	
MKE	037	NN13	–	–	–	–	–	
	047	NN14	NN14	–	–	–	–	
	098	–	–	NN06	NN06	–	–	
	118	–	–	–	NN09	NN09	–	
MAD	100	–	–	–	–	NN09	–	
	130	–	–	–	–	NN11 <sup>1)</sup>	NN11 <sup>1)</sup>	
	160	–	–	–	–	–	NN12 <sup>1)</sup>	
MAF	100	–	–	–	–	NN08	–	
	130	–	–	–	–	NN11 <sup>1)</sup>	NN11 <sup>1)</sup>	

<sup>1)</sup> Combination only possible with single-stage gearboxes

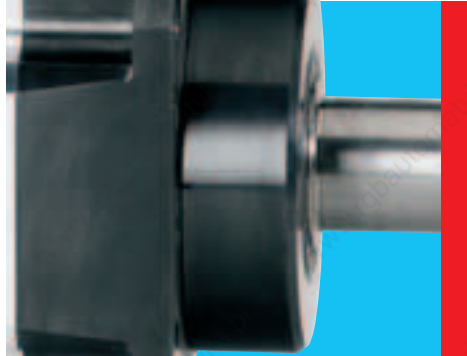

## High-precision and flexibility

- ! High-precision gearing for highest positioning accuracy
- ! Minimum power dissipation in continuous operation
- ! Optimized gear tooth forming for silent operation
- ! Environment-resistant, hermetically sealed housing
- ! High acceleration torque is achievable through a compact and rigid construction

## Your benefits

Gearbox	Transmission ratio		Nominal input speed	Maximum input speed	Maximum output speed	Nominal input torque	Nominal output torque	Maximum input torque	Maximum output torque	Backlash standard/reduced	Torsional stiffness	Efficiency	Moment of inertia	Mass
	i		n <sub>IN</sub> N [rpm]	n <sub>IN</sub> Max [rpm]	n <sub>OUT</sub> Max [rpm]	M <sub>IN</sub> N [Nm]	M <sub>OUT</sub> N [Nm]	M <sub>IN</sub> Max [Nm]	M <sub>OUT</sub> Max [Nm]	- [arcmin]	D [Nm/arcmin]	η [%]	J [kgcm <sup>2</sup> ]	m [kg]
GTM060	single-stage	4	3,000	5,000	1,250	6.25	25	12.5	50	≤ 6/≤ 3	3.5	≥ 97	0.16	1.6
		5	4,000	6,300	1,260	5.00	25	10	50				0.16	
		7	5,000	8,000	1,143	3.60	25	7.1	50				0.15	
		10	6,000	10,000	1,000	2.00	20	4	40				0.14	
	two-stage	20	4,000	6,300	315	1.25	25	2.5	50	≤ 8/≤ 6	≥ 94	0.12	2.2	
		50	6,000	10,000	200	0.50	25	1	50			0.10		
GTM075	single-stage	4	3,000	5,000	1,250	21.30	85	42.5	170	≤ 6/≤ 3	8.2	≥ 97	0.55	2.9
		5	4,000	6,300	1,260	20.00	100	40	200				0.47	
		7	5,000	8,000	1,143	12.10	85	24.3	170				0.41	
		10	6,000	10,000	1,000	6.00	60	11	110				0.38	
	two-stage	20	4,000	6,300	315	4.25	85	8.5	170	≤ 8/≤ 6	≥ 94	0.47	3.8	
		50	6,000	10,000	200	2.00	100	4	200			0.47		
GTM100	single-stage	3	2,300	4,000	1,333	40.00	120	73.3	220	≤ 4/≤ 2	24	≥ 97	2.80	5.7
		4	2,500	4,000	1,000	42.50	170	85	340				2.00	
		5	3,000	5,000	1,000	40.00	200	80	400				1.64	
		7	4,000	6,300	900	24.30	170	48.6	340				1.36	
	two-stage	10	5,000	8,000	800	12.00	120	22	220	≤ 6/≤ 4	≥ 94	1.22	7.5	
		20	3,000	5,000	250	8.50	170	17	340			1.56		
GTM140	single-stage	3	1,800	3,200	1,067	93.30	280	186.7	560	≤ 4/≤ 2	48	≥ 97	8.20	11.5
		4	2,000	3,200	800	105.00	420	210	840				6.75	
		5	2,500	4,000	800	100.00	500	200	1,000				5.54	
		7	3,000	5,000	714	60.00	420	120	840				4.59	
	two-stage	10	4,000	6,300	630	28.00	280	56	560	≤ 6/≤ 4	≥ 94	4.10	15	
		20	2,500	4,000	200	21.00	420	42	840			5.29		
GTM180	single-stage	3	1,300	2,500	833	240.00	720	480	1,440	≤ 4/≤ 2	148	≥ 97	36.00	27
		4	1,500	2,500	625	255.00	1,020	510	2,040				24.50	
		5	2,000	3,200	640	240.00	1,200	480	2,400				18.80	
		7	2,500	4,000	571	145.70	1,020	291.4	2,040				14.50	
	two-stage	10	3,000	5,000	500	72.00	720	144	1,440	≤ 6/≤ 4	≥ 94	12.30	35	
		20	2,000	3,200	160	51.00	1,020	102	2,040			6.95		
GTM240	single-stage	50	3,000	5,000	100	24.00	1,200	48	2,400			5.45		
		3	800	2,000	667	600.00	1,800	1,000	3,000	≤ 4/≤ 2	340	≥ 97	128.00	62
		4	1,000	2,000	500	625.00	2,500	1,250	5,000				97.60	
		5	1,200	2,500	500	600.00	3,000	1,200	6,000				76.40	
		7	1,500	3,000	429	357.10	2,500	714.3	5,000				59.90	
10	2,000	3,500	350	180.00	1,800	300	3,000	51.10						

## Standard and geared motors – for simple applications

For use with frequency converters we recommend combining IndraDrive with geared motors or three-phase asynchronous motors made by NORD Drive Systems or VEM Motors.

Upon request we can supply all-in-one solutions, comprising of control units and motors also sourced directly from Rexroth.

Our range of geared motors covers various types of gears of different performance categories:

- Spur gear motors with rated outputs of up to 160 kW and torques of up to 26,000 Nm

- Offset geared motors with rated outputs of up to 200 kW and torques of up to 200,000 Nm
- Bevel gear motors with rated outputs of up to 160 kW and torques of up to 32,000 Nm
- Worm gear motors with rated outputs of up to 15 kW and torques of up to 3,000 Nm

Our range of three-phase asynchronous motors includes:

- Standard motors with rated outputs of up to 500 kW
- Energy-saving motors with rated outputs of up to 335 kW

These motors are particularly suitable for operation with frequency converters and boast the following features:

- Motor design conforming to DIN EN 60034 (IEC 72)
- Mounting dimensions and output correlation compliant with DIN 42673, 42677
- Robust, low-vibration version in gray cast iron
- Protection category IP 55, higher protection category up to IP 65 optional
- Insulation class F with thermal reserve, insulation class H optional
- Further options include brakes, feedback, position of terminal box, etc.

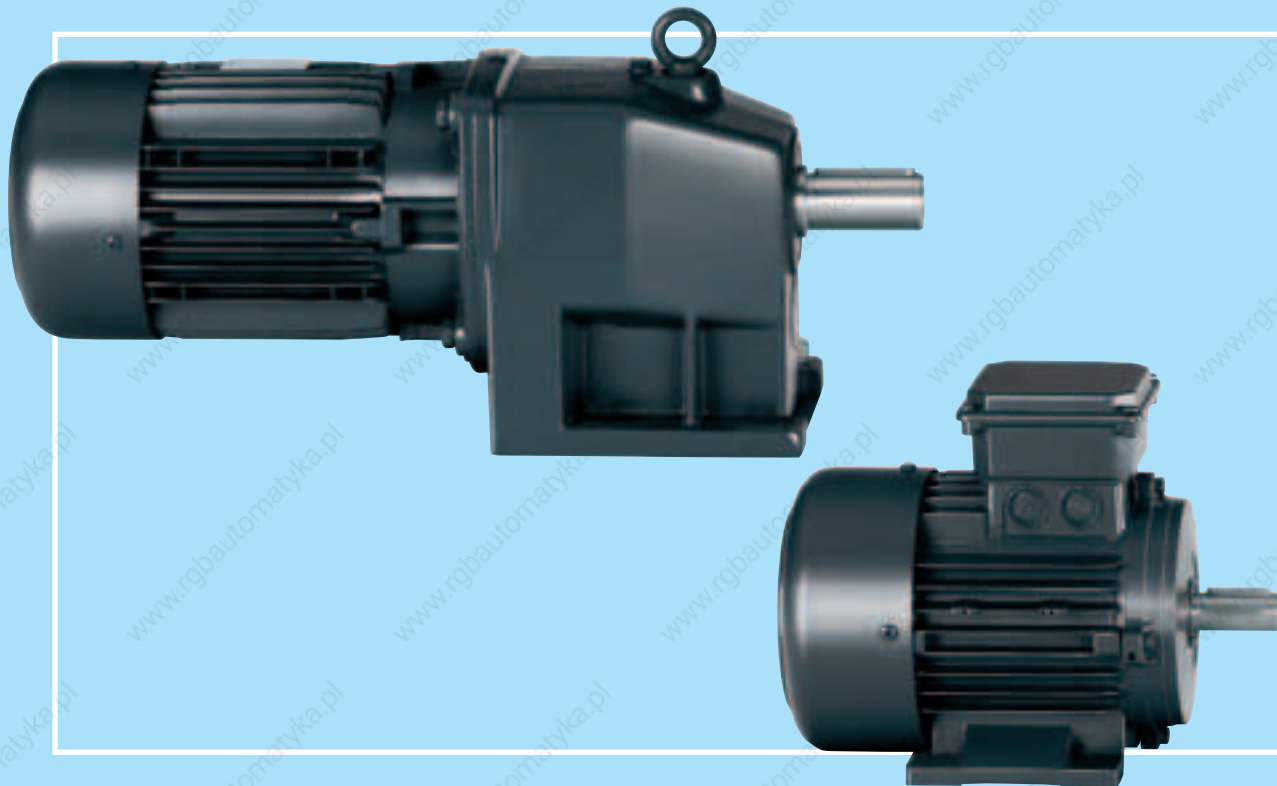

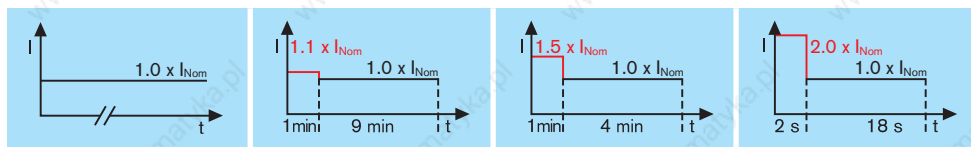

Mechanical motor output $P_{Nom}$	$I_{Nom}$	$\cos \varphi$	$\eta$	Continuous operation $1 \times I_{Nom} (> 10 \text{ min})$	Overload operation $1.1 \times I_{Nom} (1 \text{ min})$ $1 \times I_{Nom} (9 \text{ min})$	Overload operation $1.5 \times I_{Nom} (1 \text{ min})$ $1 \times I_{Nom} (4 \text{ min})$	Overload operation $2 \times I_{Nom} (2 \text{ s})$ $1 \times I_{Nom} (18 \text{ s})$
1.1 kW	2.6 A	0.79	76.6 %	HCS02.1E-W0012 HMS01.1N-W0020 HMD01.1N-W0012	HCS02.1E-W0012 HMS01.1N-W0020 HMD01.1N-W0012	HCS02.1E-W0012 HMS01.1N-W0020 HMD01.1N-W0012	HCS02.1E-W0012 HMS01.1N-W0020 HMD01.1N-W0012
1.5 kW	3.4 A	0.81	78.8 %	HCS02.1E-W0012 HMS01.1N-W0020 HMD01.1N-W0012	HCS02.1E-W0012 HMS01.1N-W0020 HMD01.1N-W0012	HCS02.1E-W0028 HMS01.1N-W0020 HMD01.1N-W0012	HCS02.1E-W0028 HMS01.1N-W0020 HMD01.1N-W0012
2.2 kW	5.2 A	0.76	81.0 %	HCS02.1E-W0028 HMS01.1N-W0020 HMD01.1N-W0012	HCS02.1E-W0028 HMS01.1N-W0020 HMD01.1N-W0012	HCS02.1E-W0028 HMS01.1N-W0020 HMD01.1N-W0012	HCS02.1E-W0028 HMS01.1N-W0020 HMD01.1N-W0012
3 kW	6.7 A	0.79	82.6 %	HCS02.1E-W0028 HMS01.1N-W0020 HMD01.1N-W0012	HCS02.1E-W0028 HMS01.1N-W0020 HMD01.1N-W0020	HCS02.1E-W0028 HMS01.1N-W0020 HMD01.1N-W0020	HCS02.1E-W0028 HMS01.1N-W0020 HMD01.1N-W0020
4 kW	8.8 A	0.78	84.2 %	HCS02.1E-W0028 HMS01.1N-W0020 HMD01.1N-W0020	HCS02.1E-W0028 HMS01.1N-W0020 HMD01.1N-W0020	HCS02.1E-W0028 HMS01.1N-W0036 HMD01.1N-W0036	HCS02.1E-W0054 <sup>1)</sup> HMS01.1N-W0036 HMD01.1N-W0036
5.5 kW	11.8 A	0.77	85.7 %	HCS02.1E-W0054 <sup>1)</sup> HMS01.1N-W0020 HMD01.1N-W0036	HCS02.1E-W0054 <sup>1)</sup> HMS01.1N-W0036 HMD01.1N-W0036	HCS02.1E-W0054 <sup>1)</sup> HMS01.1N-W0036 HMD01.1N-W0036	HCS02.1E-W0054 <sup>1)</sup> HMS01.1N-W0036 HMD01.1N-W0036
7.5 kW	15 A	0.84	87.0 %	HCS02.1E-W0054 <sup>1)</sup> HMS01.1N-W0036 HMD01.1N-W0036	HCS02.1E-W0054 <sup>1)</sup> HMS01.1N-W0036 HMD01.1N-W0036	HCS02.1E-W0070 <sup>1)</sup> HMS01.1N-W0036 HMD01.1N-W0036	HCS02.1E-W0070 <sup>1)</sup> HMS01.1N-W0036 HMD01.1N-W0036
11 kW	21 A	0.85	88.4 %	HCS02.1E-W0070 <sup>1)</sup> HMS01.1N-W0036	HCS02.1E-W0070 <sup>1)</sup> HMS01.1N-W0054	HCS02.1E-W0070 <sup>1)</sup> HMS01.1N-W0054	HCS03.1E-W0070 <sup>1)</sup> HMS01.1N-W0054
15 kW	28 A	0.86	89.4 %	HCS03.1E-W0070 <sup>1)</sup> HMS01.1N-W0054	HCS03.1E-W0070 <sup>1)</sup> HMS01.1N-W0054	HCS03.1E-W0070 <sup>1)</sup> HMS01.1N-W0070	HCS03.1E-W0070 <sup>1)</sup> HMS01.1N-W0070
18.5 kW	34.5 A	0.86	90.0 %	HCS03.1E-W0070 <sup>1)</sup> HMS01.1N-W0054	HCS03.1E-W0070 <sup>1)</sup> HMS01.1N-W0070	HCS03.1E-W0100 <sup>1)</sup> HMS01.1N-W0150	HCS03.1E-W0100 <sup>1)</sup> HMS01.1N-W0150
22 kW	42 A	0.84	90.5 %	HCS03.1E-W0070 <sup>1)</sup> HMS01.1N-W0070	HCS03.1E-W0100 <sup>1)</sup> HMS01.1N-W0150	HCS03.1E-W0100 <sup>1)</sup> HMS01.1N-W0150	HCS03.1E-W0100 <sup>1)</sup> HMS01.1N-W0150
30 kW	55.5 A	0.85	91.5 %	HCS03.1E-W0100 <sup>1)</sup> HMS01.1N-W0150	HCS03.1E-W0100 <sup>1)</sup> HMS01.1N-W0150	HCS03.1E-W0150 <sup>1)</sup> HMS01.1N-W0150	HCS03.1E-W0150 <sup>1)</sup> HMS01.1N-W0150
37 kW	67 A	0.86	92.5 %	HCS03.1E-W0100 <sup>1)</sup> HMS01.1N-W0150	HCS03.1E-W0150 <sup>1)</sup> HMS01.1N-W0150	HCS03.1E-W0150 <sup>1)</sup> HMS01.1N-W0150	HCS03.1E-W0150 <sup>1)</sup> HMS01.1N-W0150
45 kW	81 A	0.86	93.0 %	HCS03.1E-W0150 <sup>1)</sup> HMS01.1N-W0150	HCS03.1E-W0150 <sup>1)</sup> HMS01.1N-W0150	HCS03.1E-W0210 <sup>1)</sup> HMS01.1N-W0210	HCS03.1E-W0210 <sup>1)</sup> HMS01.1N-W0210
55 kW	98.5 A	0.86	93.5 %	HCS03.1E-W0210 <sup>1)</sup> HMS01.1N-W0150	HCS03.1E-W0210 <sup>1)</sup> HMS01.1N-W0210	HCS03.1E-W0210 <sup>1)</sup> HMS01.1N-W0210	HCS03.1E-W0210 <sup>1)</sup> HMS01.1N-W0210
75 kW	134 A	0.86	94.1 %	HCS03.1E-W0210 <sup>1)</sup> HMS01.1N-W0210	HCS03.1E-W0210 <sup>1)</sup> HMS01.1N-W0210	-	-

The examples selected are based on the operation of 4-pole standard motors for 3 AC 400 V/50 Hz at a switching frequency of 4 kHz and a rotational frequency > 4 Hz

<sup>1)</sup>with HNL power choke

# Auxiliary components





## Accessories for all requirements

- Filters and chokes for EMC-proof operation
- Components designed to absorb high braking forces
- Energy storage capacitors for dynamic sequences
- Accessories for simplified assembly and installation

# Your benefits

### Line filters

- EMC filters for the power supply units and converters
- for reduced circuit feedback

### Line filters with integrated power choke

- for direct mounting on HCS03 series converters

### Power chokes

- for increased DC bus continuous output
- for reduced harmonics

### Motor filters

- to protect the motor winding from extreme voltage rises
- for effective reduction of malfunctions in the motor supply line

### Braking resistors

- for input power during regenerative operation
- for direct mounting on HCS03 series converters

### Brake units

- braking resistor and braking transistor in one unit
- for increased braking power

### DC bus capacitor

- capacitor unit for dynamic energy storage
- can be combined with power supply units or converters to save space

### Other accessories

- basic accessories for assembly and installation
- shielded connection plates for EMC-compatible connection of the motor cable to the power unit
- control cabinet adapter for combining control units of different depths
- modular bus extension to bridge larger than average distances between drive groups



# Line filters – for HMV01 power supply units and HCS02 converters

Line filters	Continuous current	Power dissipation	Width W	Height H	Depth D	Mass
for HMV01 power supply units	A	W	mm	mm	mm	kg
HNFO1.1A-F240-E0051-A-480-NNNN	51	< 89	100	440	262	15
HNFO1.1A-M900-E0051-A-480-NNNN	51	< 91	100	440	262	15
HNFO1.1A-F240-E0125-A-480-NNNN	125	< 127	150	440	262	18
HNFO1.1A-M900-E0125-A-480-NNNN	125	< 174	150	440	262	30
HNFO1.1A-F240-E0202-A-480-NNNN	202	< 238	150	440	262	29
HNFO1.1A-M900-E0202-A-480-NNNN	202	< 373	250	440	262	37
HNFO1.1A-F240-R0026-A-480-NNNN	26	< 73	100	440	262	14
HNFO1.1A-M900-R0026-A-480-NNNN	26	< 77	150	440	262	17
HNFO1.1A-F240-R0065-A-480-NNNN	65	< 163	150	440	262	25
HNFO1.1A-M900-R0065-A-480-NNNN	65	< 157	150	440	262	26
HNFO1.1A-F240-R0094-A-480-NNNN	94	< 135	150	440	262	28
HNFO1.1A-M900-R0094-A-480-NNNN	94	< 146	150	440	262	29
for HCS02 converters	A	W	mm	mm	mm	kg
NFD03.1-480-007	7	3.9	50	160	90	0.7
NFD03.1-480-016	16	6.4	55	220	90	1
NFD03.1-480-055	55	25.9	90	220	105	2
NFD03.1-480-075	75	30.4	90	240	145	3.5

All data applies to nominal rating at 3 AC 400 V mains voltage.

The exact assignment to the power units can be found in the selection overview tables on page 88 and following.



Line filters ensure that the EMC limit values are adhered to and suppress leakage current generated by line capacitors.

Our line filters are optimally coordinated with the power units and are scalable in regards to current, number of drives and motor cable length.

They can be combined with our shielded motor cables for trouble-free operation conforming to EN 61800-3, Class A, Group 2, even with cable lengths of up to 75 m.

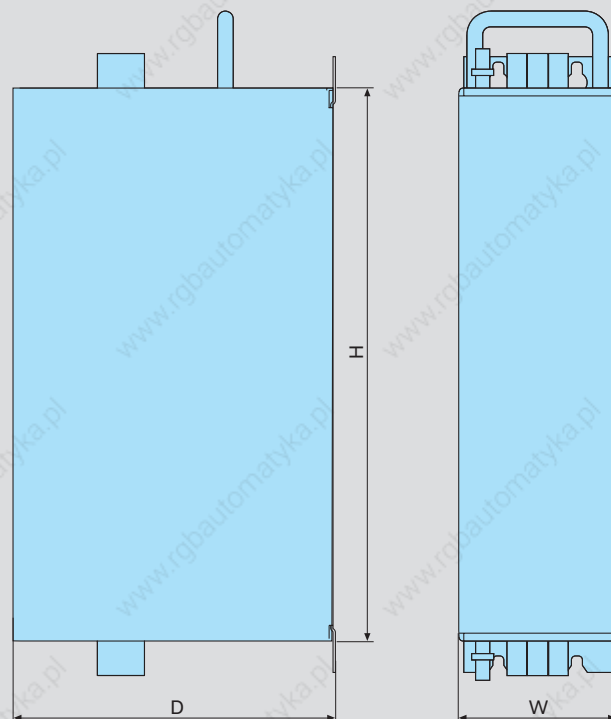

# Line filters with integrated power choke – for HCS03 converters

Line filters with integrated power choke	Continuous current	Power dissipation	Nominal inductance	Capacitance	Width W	Height H	Depth D	Mass
	A	W	$\mu\text{H}$	$\mu\text{F}$	mm	mm	mm	kg
HNK01.1A-A075-E0050-A-500-NNNN	50	50	3 x 571	3 x 1.1	125	322.5	251.5	15
HNK01.1A-A075-E0080-A-500-NNNN	80	80	3 x 362	3 x 2.2	225	310	270	20
HNK01.1A-A075-E0106-A-500-NNNN	106	110	3 x 240	3 x 2.2	225	310	270	20
HNK01.1A-A075-E0146-A-500-NNNN	146	130	3 x 170	3 x 2.2	350	380	270	28

All data applies to nominal rating at 3 AC 400 V mains voltage.

The exact assignment to the power units can be found in the selection overview tables on page 88 and following.

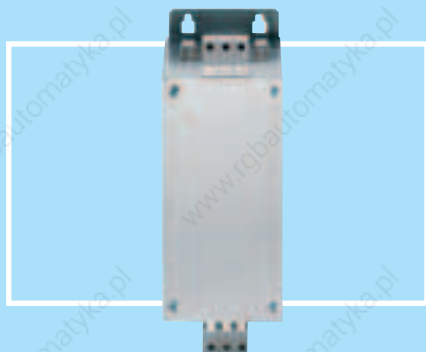

The combination of line filter and power choke in one unit simplifies assembly and installation. It is simply fitted underneath the converter to form one space-saving unit. It is also a particularly easy way to comply with the directives contained in EN 61800-3, Class A, Group 2.

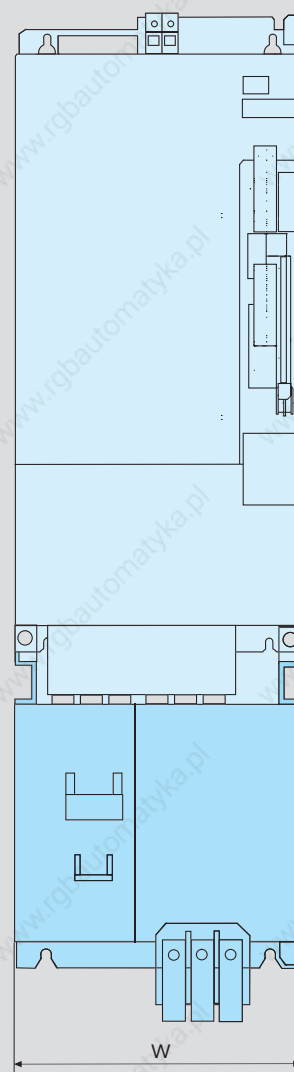
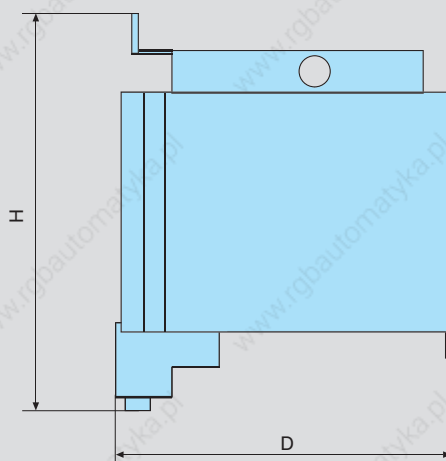

Example of assembly

# Power chokes – for HMV01 power supply units and HCS02 converters

Power choke	Continuous current	Power dissipation	Nominal inductance	Capacitance	Width W	Height H	Depth D	Mass
	A	W	$\mu\text{H}$	$\mu\text{F}$	mm	mm	mm	kg
HNL01.1E-1000-N0012-A-500-NNNN	12	40	3 x 1,000	–	120	164	61	2.7
HNL01.1E-1000-N0020-A-500-NNNN	20	60	3 x 1,000	–	150	184	66.5	3.8
HNL01.1E-0600-N0032-A-500-NNNN	32	75	3 x 600	–	150	184	66.5	4.5
HNL01.1E-0400-N0051-A-480-NNNN	51	165	3 x 400	–	180	225	112	13.5
HNL01.1E-0200-N0125-A-480-NNNN	125	170	3 x 200	–	230	295	148	24
HNL01.1E-0100-N0202-A-480-NNNN	202	200	3 x 100	–	265	350	152	33
HNL01.1R-0980-C0026-A-480-NNNN	26	225	3 x 980	3 x 10	210	245	172	16
HNL01.1R-0590-C0065-A-480-NNNN	65	310	3 x 590	3 x 20	300	360	205	45
HNL01.1R-0540-C0094-A-480-NNNN	94	420	3 x 540	3 x 20	340	385	229	65

All data applies to nominal rating at 3 AC 400 V mains voltage.

The exact assignment to the power units can be found in the selection overview tables on page 88 and following.



Power chokes can be used as optional extras with power supply units to increase the permissible continuous DC bus output of power supply units and converters.

When using supply units with line regeneration, these components are always required.

They reduce the harmonics in the line current while simultaneously preventing circuit feedback.

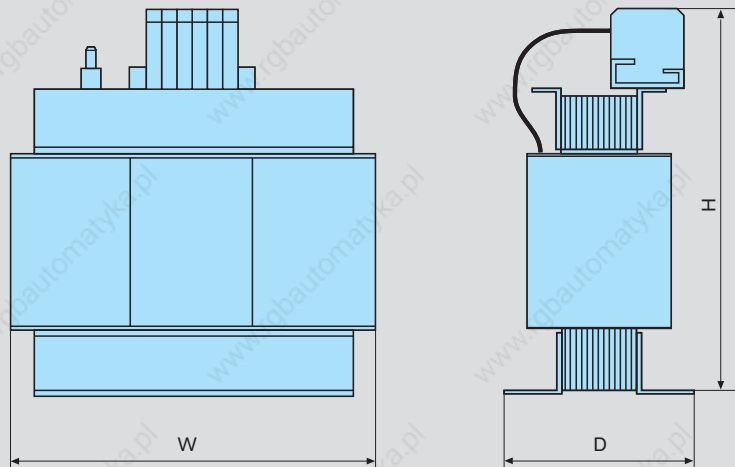

# Power chokes – for HCS03 converters

Power choke	Continuous current	Power dissipation	Nominal inductance	Width W	Height H	Depth D	Mass
	A	W	$\mu\text{H}$	mm	mm	mm	kg
HNL01.1E-0571-N0050-A-500-NNNN	50	50	3 x 571	100	208	183	13
HNL01.1E-0362-N0080-A-500-NNNN	80	80	3 x 362	205	175	180	17
HNL01.1E-0240-N0106-A-500-NNNN	106	100	3 x 240	205	193	210	17
HNL01.1E-0170-N0146-A-500-NNNN	146	130	3 x 170	250	205	230	23

All data applies to nominal rating at 3 AC 400 V mains voltage.

The exact assignment to the power units can be found in the selection overview tables on page 88 and following.

HCS03 series converters achieve higher continuous DC bus output when combined with the power chokes. They reduce the harmonics in the line current, thereby preventing circuit feedback.

This combination always complies to the permissible EMC values for industrial networks stipulated by EN 61000-2-4.

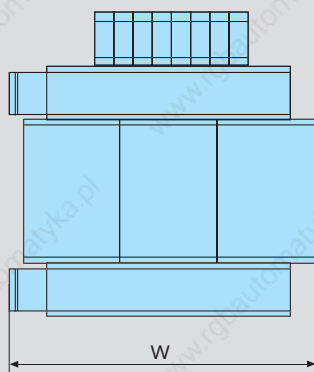

HNL01.1E-0571...

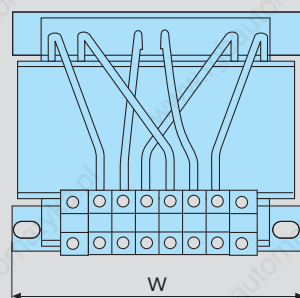
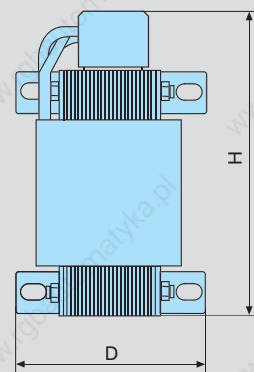

HNL01.1E-0362... to HNL01.1E-0170...

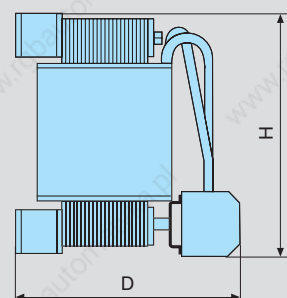

## Motor filters – for HCS03 converters

Motor filter	Continuous current	Power dissipation	Inductance	Width W	Height H	Depth D	Mass
	A	W	$\mu\text{H}$	mm	mm	mm	kg
HMF01.1A-N0K2-D0045-A-500-NNNN	45	120	3 x 160	125	330	270	15
HMF01.1A-N0K2-D0073-A-500-NNNN	72	160	3 x 100	225	315	270	20
HMF01.1A-N0K2-D0095-A-500-NNNN	95	190	3 x 78	225	315	270	20
HMF01.1A-N0K2-D0145-A-500-NNNN	145	220	3 x 50	350	400	260	38

All data applies to nominal rating at 3 AC 400 V mains voltage and 4 kHz clock frequency. The maximum output frequency is 200 Hz. The exact assignment to the power units can be found in the selection overview tables on page 88 and following.



The combination of the steep switching curves of modern converters and long motor wires can often cause transient overvoltages on the motor terminals. This, along with the leakage current of the motor wires, can be reduced by using a motor filter on the inverter output.

This has the following advantages:

- Voltage rise limited to values below 1 kV/ $\mu\text{s}$
- Winding insulation protected by limiting the voltage peak to max. 1,000 V
- Operation of several motors connected in parallel on one frequency converter via long supply lines
- Compliance with increased EMC requirements thanks to reduced interference voltages

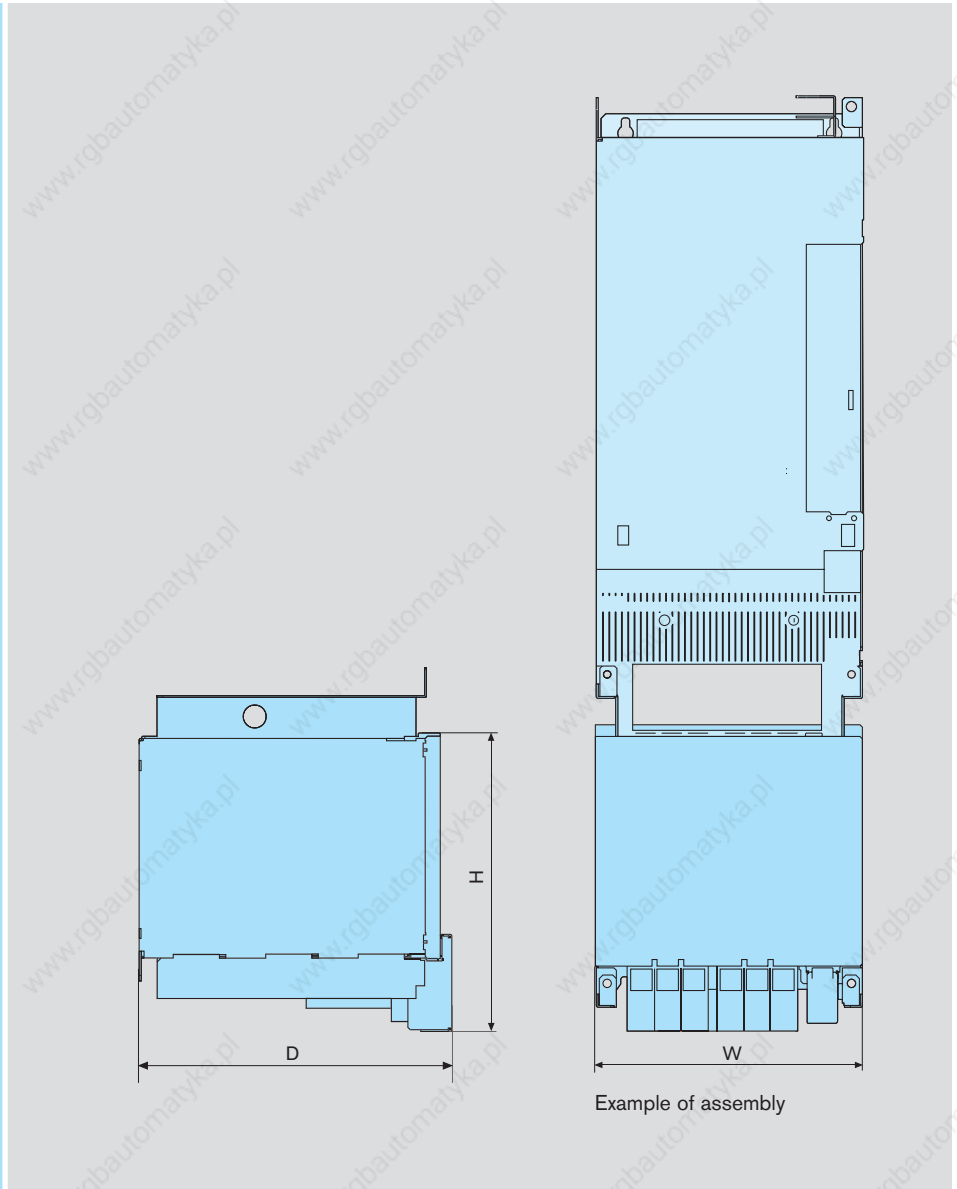

# Brake resistors – for HCS03 converters

Brake resistor	Maximum energy	Braking power				Resistance	Width W	Height H	Depth D	Mass
	consumption	duration	max.	t <sub>on</sub> time	t <sub>cycle</sub> time					
	kWs	kW	kW	s	s					
HLR01.1N-0300-N17R5-A-007-NNNN	37	0.30	37	1	120	20.5	123	300	196	3
HLR01.1N-0470-N11R7-A-007-NNNN	56	0.47	56	1	120	13.7	223	300	210	4.5
HLR01.1N-0780-N07R0-A-007-NNNN	93	0.78	93	1	120	8.2	223	300	210	5.5
HLR01.1N-1K08-N05R0-A-007-NNNN	130	1.08	130	1	120	5.8	350	300	220	8

The exact assignment to the power units can be found in the selection overview tables on page 88 and following.



When using the HCS03 converters in regenerative operation there is a choice of particularly compact brake resistors for various different levels of power consumption.

The brake resistor is mounted directly above the converter. This space-saving arrangement also simplifies the installation work. At the same time the converter's extracted air flow makes an effective cooling system.

The robust construction and high dielectric strength of the resistor elements enables high power and impulse loading. The resistor elements are flame-proof and are protected from harmful environmental factors by their full encapsulation.

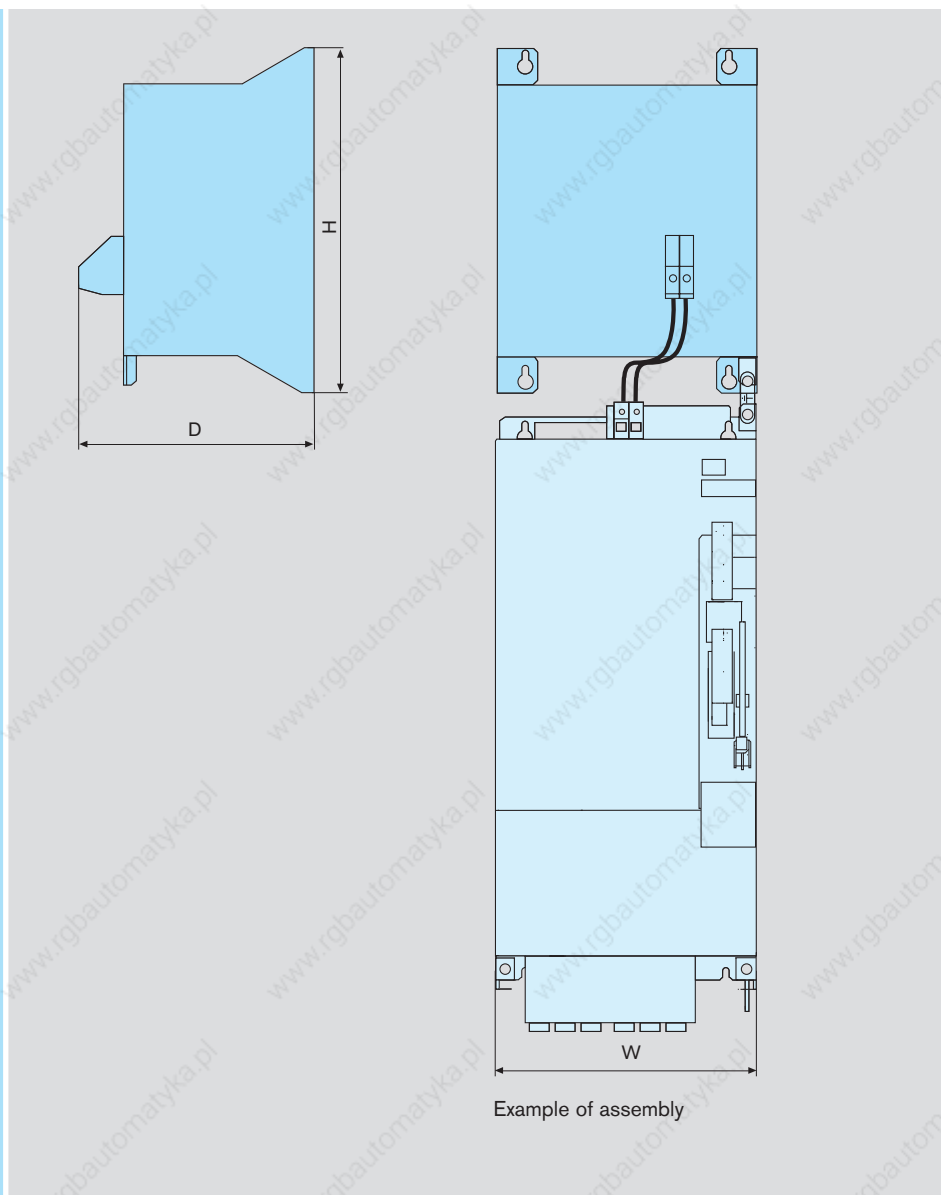

# Brake resistors, heavy-duty version – for HCS03 converters

Brake resistor	Maximum energy consumption	Braking power				Resistance	Type	Width W	Height H	Depth D	Mass
		duration	max.	$t_{on}$ time	$t_{cycle}$ time						
		kW	kW	s	s						
HLR01.1N-01K6-N18R0-A-007-NNNN	109	1.6	34	3.3	120	20.0	A	185	586	120	5.2
HLR01.1N-03K5-N19R0-A-007-NNNN	252	3.5	31	8	120	21.3	B	300	270	490	9.5
HLR01.1N-04K5-N18R0-A-007-NNNN	432	4.5	33	13	120	20.2	B	400	270	490	13
HLR01.1N-06K5-N18R0-A-007-NNNN	686	6.5	33	21	120	20.2	B	400	270	490	13
HLR01.1N-10K0-N18R0-A-007-NNNN	1,080	10	33	32	120	20.2	B	600	270	490	22
HLR01.1N-02K0-N15R0-A-007-NNNN	137	2	40	3.4	120	16.7	A	185	686	120	6.2
HLR01.1N-05K0-N15R0-A-007-NNNN	360	5	40	9	120	16.9	B	400	270	490	13
HLR01.1N-07K0-N14R0-A-007-NNNN	672	7	43	16	120	15.7	B	600	270	490	22
HLR01.1N-09K5-N13R0-A-007-NNNN	1,003	9.5	46	22	120	14.6	B	600	270	490	22
HLR01.1N-14K5-N13R0-A-007-NNNN	1,566	14.5	46	34	120	14.6	B	800	270	490	33
HLR01.1N-04K5-N07R4-A-007-NNNN	246	4.5	81	3	120	8.3	B	300	270	490	9.5
HLR01.1N-08K5-N08R0-A-007-NNNN	612	8.5	75	8.2	120	9.0	B	600	270	490	22
HLR01.1N-11K0-N07R3-A-007-NNNN	1,056	11	82	13	120	8.2	B	600	270	490	22
HLR01.1N-15K0-N08R1-A-007-NNNN	1,584	15	74	21	120	9.1	B	800	270	490	33
HLR01.1N-24K0-N07R2-A-007-NNNN	2,592	24	83	31	120	8.1	C	795	710	490	80
HLR01.1N-06K5-N06R1-A-007-NNNN	356	6.5	98	3.6	120	6.9	B	400	270	490	13
HLR01.1N-12K5-N05R5-A-007-NNNN	900	12.5	109	8.3	120	6.2	B	800	270	490	33
HLR01.1N-17K0-N05R1-A-007-NNNN	1,632	17	117	14	120	5.7	B	1,000	270	490	43
HLR01.1N-23K0-N05R5-A-007-NNNN	2,429	23	109	22	120	6.2	C	595	710	490	56
HLR01.1N-36K0-N05R4-A-007-NNNN	3,888	36	111	35	120	6.1	C	995	710	490	93

The exact assignment to the power units can be found in the selection overview tables on page 88 and following.

The heavy-duty version of the brake resistor must always be used in applications where high regeneration occurs over a relatively long period of time. This is the case, for example, when lowering large loads or when braking high mass moments of inertia.

Depending on the braking power required there is a choice of compact brake resistors of different power levels and designs for each converter.

Type A

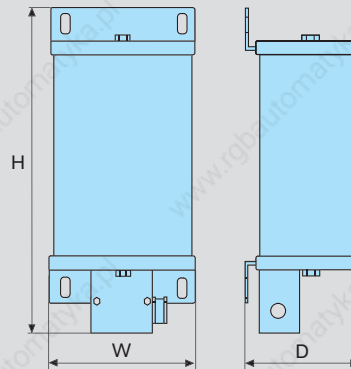

Type C

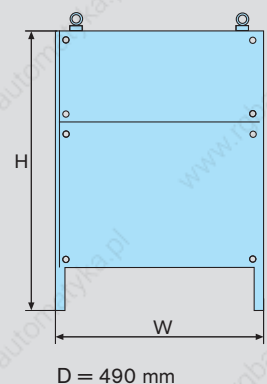

Type B

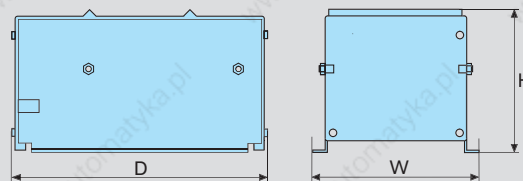

# Brake units – for HMV01 power supply units and HCS02 converters

Brake unit	Maximum energy consumption	Braking power				Width W	Height H	Depth D	Mass
		duration	max.	t <sub>on</sub> time	t <sub>cycle</sub> time				
	kWs	kW	kW	s	s	mm	mm	mm	kg
HLB01.1C-01K0-N06R0-A-007-NNNN	100	1	100	5	100	65	352	251.5	5.8
HLB01.1D-02K0-N03R4-A-007-NNNN	500	2	100	1	250	100	440	309	12.2

The exact assignment to the power units can be found in the selection overview tables on page 88 and following.



The connection of brake units increases the continuous and peak regenerative power.

The brake unit also makes it possible to have the DC bus short circuit function available in the drive system.

This function makes it possible to brake the synchronous motors even in the event of a power failure.

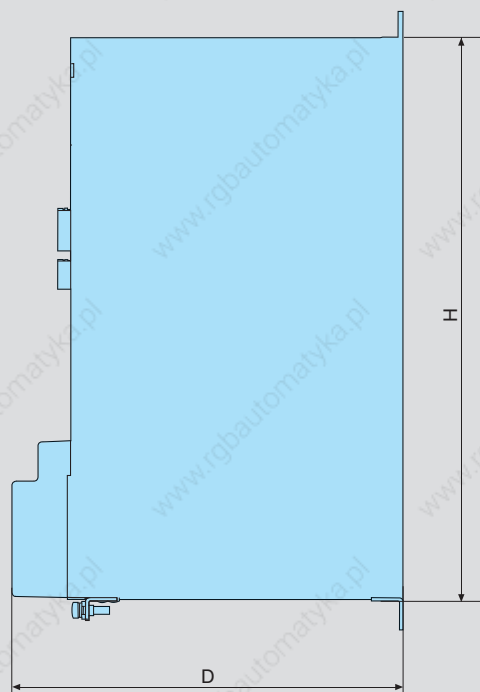
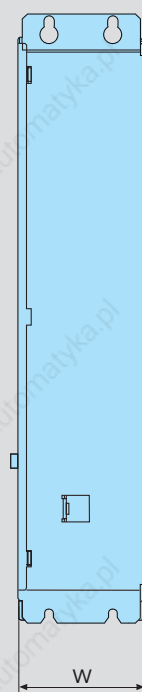

# DC bus capacitors – for HMV01 power supply units and HCS02 converters

DC bus capacitor	Capacitance	Width W	Height H	Depth D	Mass
	mF	mm	mm	mm	kg
HLC01.1C-01M0-A-007-NNNN	1	50	352	251.5	3.2
HLC01.1C-02M4-A-007-NNNN	2.4	50	352	251.5	4.3
HLC01.1D-05M0-A-007-NNNN	5	75	440	309	8.6

The exact assignment to the power units can be found in the selection overview tables on page 88 and following.



DC bus capacitors improve the energy balance in applications where machining cycles take place in rapid succession, such as roll feeds or cross cutting lines.

Connected to the DC link, the DC bus capacitor acts as a temporary energy storage unit and reduces the heat loss in the control cabinet by relieving the braking resistor.

In the event of a power failure the reserve energy enables a controlled retraction motion. This protects the workpiece and the tool, e.g. in gear cutting machines.

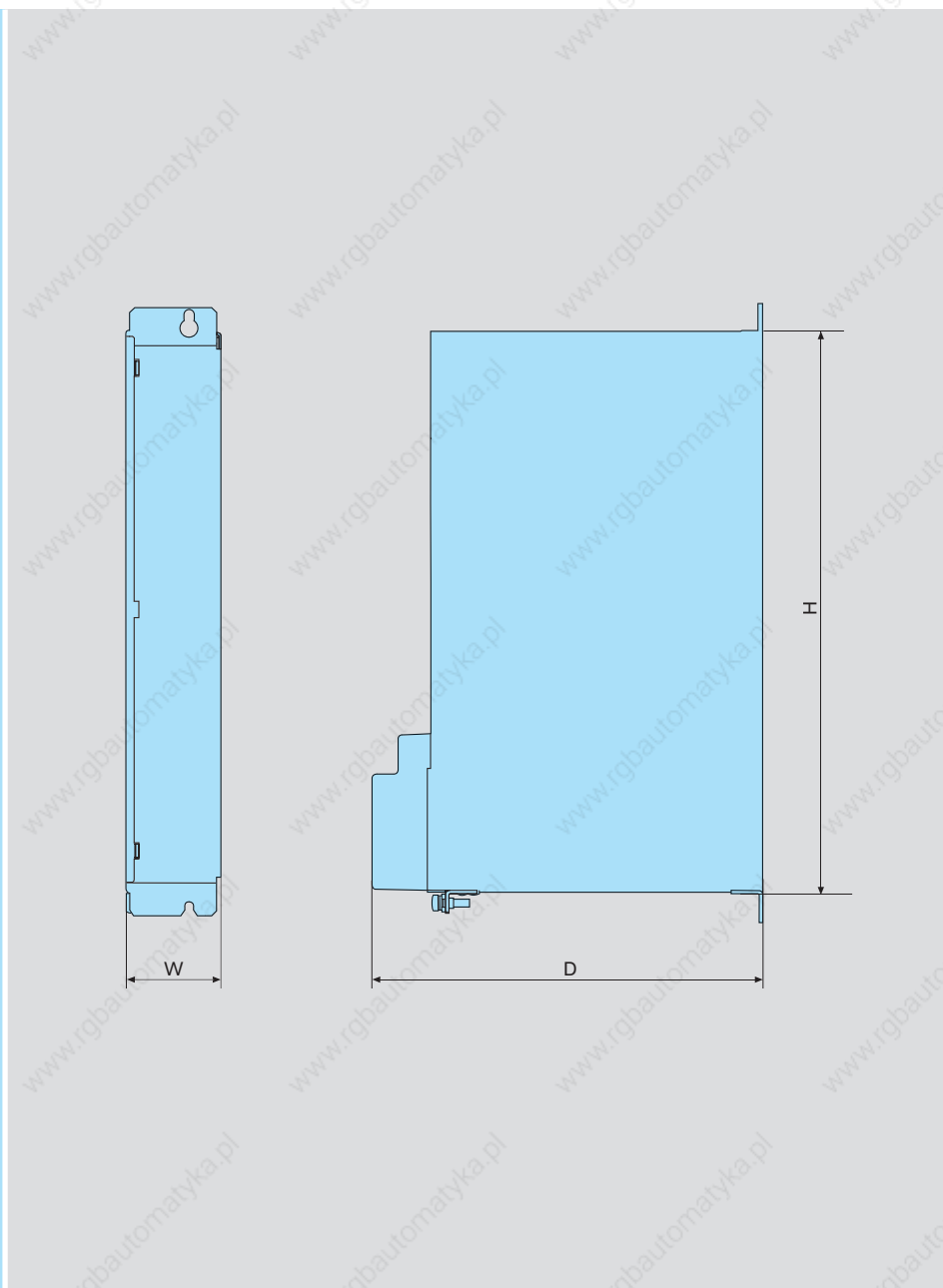

## Other accessories



### Basic accessories HAS01

The basic accessories contain all the mounting parts and fixing elements. Depending on the application, we supply these accessories complete with all the connecting bars for control voltage and DC bus.



### Shield connection HAS02

The shield connection plate is an EMC-compatible method of connecting the motor cable to your control unit. It also serves as a cord grip.

### Control cabinet adapter HAS03

The control cabinet adapters are used to combine HCS02 converters and their auxiliary components options, HLB brake unit and HLC expansion capacitor, with units from the IndraDrive M series. Spacer bolts can be used to even out the lower unit depth thus creating an even frontage with a uniform installation height.

### Module bus extension RKB0001

All the control units are fitted with a bus cable – matched to the respective unit width – to transmit the control signals.

Where there are relatively large distances between individual control units we can supply the necessary module bus extensions. These come in various lengths ranging from 0.5 m and 40 m.



Components	HMV01. 1E-W0030	HMV01. 1E-W0075	HMV01. 1E-W0120	HMV01. 1R-W0018	HMV01. 1R-W0045	HMV01. 1R-W0065	HCS02. 1E-W0012	HCS02. 1E-W0028	HCS02. 1E-W0054	HCS02. 1E-W0070	HCS03. 1E-W0070	HCS03. 1E-W0100	HCS03. 1E-W0150	HCS03. 1E-W0210
------------	--------------------	--------------------	--------------------	--------------------	--------------------	--------------------	--------------------	--------------------	--------------------	--------------------	--------------------	--------------------	--------------------	--------------------

#### Motor filter HMF

HMF01.1A-N0K2-D0045-A-500-NNNN											●			
HMF01.1A-N0K2-D0073-A-500-NNNN												●		
HMF01.1A-N0K2-D0095-A-500-NNNN													●	
HMF01.1A-N0K2-D0145-A-500-NNNN														●

#### Brake resistor HLR

HLR01.1N-0300-N17R5-A-007-NNNN											●			
HLR01.1N-01K6-N18R0-A-007-NNNN											○			
HLR01.1N-03K5-N19R0-A-007-NNNN											○			
HLR01.1N-04K5-N18R0-A-007-NNNN											○			
HLR01.1N-06K5-N18R0-A-007-NNNN											○			
HLR01.1N-10K0-N18R0-A-007-NNNN											○			
HLR01.1N-0470-N11R7-A-007-NNNN												●		
HLR01.1N-02K0-N15R0-A-007-NNNN												○		
HLR01.1N-05K0-N15R0-A-007-NNNN												○		
HLR01.1N-07K0-N14R0-A-007-NNNN												○		
HLR01.1N-09K5-N13R0-A-007-NNNN												○		
HLR01.1N-14K5-N13R0-A-007-NNNN												○		
HLR01.1N-0780-N07R0-A-007-NNNN													●	
HLR01.1N-04K5-N07R4-A-007-NNNN													○	
HLR01.1N-08K5-N08R0-A-007-NNNN													○	
HLR01.1N-11K0-N07R3-A-007-NNNN													○	
HLR01.1N-15K0-N08R1-A-007-NNNN													○	
HLR01.1N-24K0-N07R2-A-007-NNNN													○	
HLR01.1N-1K08-N05R0-A-007-NNNN														●
HLR01.1N-06K5-N06R1-A-007-NNNN														○
HLR01.1N-12K5-N05R5-A-007-NNNN														○
HLR01.1N-17K0-N05R1-A-007-NNNN														○
HLR01.1N-23K0-N05R5-A-007-NNNN														○
HLR01.1N-36K0-N05R4-A-007-NNNN														○

● Standard version ○ Heavy-duty version

#### Brake unit HLB

HLB01.1C-01K0-N06R0-A-007-NNNN	○	○	○	○	○	○		●	●	●	○	○	○	○
HLB01.1D-02K0-N06R0-A-007-NNNN	●	●	●	●	●	●		○	○	○	●	●	●	●

○ With control cabinet adapter HAS03 to even out the different unit depths

#### DC Bus capacitor HLC

HLC01.1C-01M0-A-007-NNNN	○	○	○	○	○	○		●	●	●				○
HLC01.1C-02M4-A-007-NNNN	○	○	○	○	○	○		●	●	●				○
HLC01.1D-05M0-A-007-NNNN	●	●	●	●	●	●								●

○ With control cabinet adapter HAS03 to even out the different unit depths



Components	HMS01.1N-W0020	HMS01.1N-W0036	HMS01.1N-W0054	HMS01.1N-W0070	HMS01.1N-W0150	HMS01.1N-W0210	HMD01.1N-W0012	HMD01.1N-W0020	HMD01.1N-W0036	HCS02.1E-W0012	HCS02.1E-W0028	HCS02.1E-W0054	HCS02.1E-W0070	HCS03.1E-W0070	HCS03.1E-W0100	HCS03.1E-W0150	HCS03.1E-W0210	HNK01.1A...-E0050	HNK01.1A...-E0080	HNK01.1A...-E0106	HNK01.1A...-E0146
------------	----------------	----------------	----------------	----------------	----------------	----------------	----------------	----------------	----------------	----------------	----------------	----------------	----------------	----------------	----------------	----------------	----------------	-------------------	-------------------	-------------------	-------------------

**Shield connection HAS02**

HAS02.1-001-NNN-NN	●	●	●	●																		
HAS02.1-002-NNN-NN							●	●	●	●	●	●	●									
HAS02.1-003-NNN-NN					●	●																
HAS02.1-004-NNN-NN													●									
HAS02.1-005-NNN-NN														●	●							
HAS02.1-006-NNN-NN																	●					
HAS02.1-007-NNN-NN																		●	●			
HAS02.1-008-NNN-NN																	●					
HAS02.1-009-NNN-NN																						●

Components	HCS02.1E-W0012	HCS02.1E-W0028	HCS02.1E-W0054	HCS02.1E-W0070	HLB01.1C	HLC01.1C
------------	----------------	----------------	----------------	----------------	----------	----------

**Control cabinet adapter HAS03**

HAS03.1-002-NNN-NN	●	●			●	●
HAS03.1-004-NNN-NN			●	●		

# Auxiliary components – connection cables

Motor	Control unit	Power cable	Feedback cable
MSK030B-0900 MSK030C-0900 MSK040B-0600 MSK040C-0600 MSK050B-0300, -0600 MSK050C-0300, -0600 MSK060B-0300, -0600 MSK060C-0300, -0600	HMD01-W0012 HMx01.1N-W0020 HMx01.1N-W0036 HCS02.1N-W0012 HCS02.1N-W0028	RKL4302	
	HMS01.1N-W0054 HMS01.1N-W0070 HCS02.1N-W0054 HCS02.1N-W0070 HCS03.1E-W0070	RKL4303	
MSK070C-0150, -0300, -0450 MSK070D-0150 MSK070E-0150 MSK071D-0200, -0300, -0450 MSK071E-0200, -0300	HMD01-W0012 HMx01.1N-W0020 HMx01.1N-W0036 HCS02.1N-W0012 HCS02.1N-W0028	RKL4306	
	HMS01.1N-W0054 HMS01.1N-W0070 HCS02.1N-W0054 HCS02.1N-W0070 HCS03.1E-W0070	RKL4307	
MSK100B-0200 MSK100D-0200	HMx01.1N-W0020 HMx01.1N-W0036 HCS02.1N-W0012 HCS02.1N-W0028	RKL4325	
	HMS01.1N-W0054 HMS01.1N-W0070 HCS02.1N-W0054 HCS02.1N-W0070 HCS03.1E-W0070	RKL4320	RKG4200
MSK070D-0300, -0450 MSK070E-0300 MSK071E-0450	HMx01.1N-W0020 HMx01.1N-W0036 HCS02.1N-W0012 HCS02.1N-W0028	RKL4308	
	HMS01.1N-W0054 HMS01.1N-W0070 HCS02.1N-W0054 HCS02.1N-W0070 HCS03.1E-W0070	RKL4309	
	HMx01.1N-W0150 HMx01.1N-W0210 HCS03.1E-W0100 HCS03.1E-W0150	RKL4310	
MSK100B-0300 MSK100C-0200, -0300 MSK100D-0300	HMx01.1N-W0020 HMx01.1N-W0036 HCS02.1N-W0012 HCS02.1N-W0028	RKL4326	
	HMS01.1N-W0054 HMS01.1N-W0070 HCS02.1N-W0054 HCS02.1N-W0070 HCS03.1E-W0070	RKL4321	

Motor	Control unit	Power cable	Feedback cable
MSK100B-0400 MSK100B-0450	HMx01.1N-W0020 HMx01.1N-W0036 HCS02.1N-W0012 HCS02.1N-W0028	RKL4327	RKG4200
	HMS01.1N-W0054 HMS01.1N-W0070 HCS02.1N-W0054 HCS02.1N-W0070 HCS03.1E-W0070	RKL4322	
MSK070E-0450	HMS01.1N-W0054 HMS01.1N-W0070 HCS02.1N-W0054 HCS02.1N-W0070 HCS03.1E-W0070	RKL4314	
	HMx01.1N-W0150 HMx01.1N-W0210 HCS03.1E-W0100 HCS03.1E-W0150	RKL4315	
MSK100C-0450 MSK101D-0200, -0300 MSK101E-0200	HMS01.1N-W0054 HMS01.1N-W0070 HCS02.1N-W0054 HCS02.1N-W0070 HCS03.1E-W0070	RKL4323	
	HMS01.1N-W0150 HMS01.1N-W0210 HCS03.1E-W0100 HCS03.1E-W0150	RKL4328	
MSK101D-0450 MSK101E-0300	HMS01.1N-W0054 HMS01.1N-W0070 HCS02.1N-W0054 HCS02.1N-W0070 HCS03.1E-W0070	RKL4324	
	HMS01.1N-W0150 HMS01.1N-W0210 HCS03.1E-W0100 HCS03.1E-W0150	RKL4329	
MSK101E-0450	HMS01.1N-W0150 HMS01.1N-W0210 HCS03.1E-W0100 HCS03.1E-W0150	RKL4330	

These tables are an extract from our extensive range of cables. Cables for other motors can be found in our documentation entitled "Connection cables – selection data". All specifications given relate to motors with natural convection.

# Glossary

<b>ADVANCED</b>	Control units for maximum performance and dynamics with many configuration options
<b>BASIC</b>	Control units for standard applications
<b>Basic accessories</b>	All the mounting parts and hardware, and the connecting bars for the control voltage and DC bus
<b>Brake chopper</b> <b>Brake transistor</b>	Transistor which switches a braking resistor on and off
<b>Brake unit</b>	All-in-one unit comprising braking resistor and braking transistor (brake chopper) used to increase the braking power
<b>Braking power</b>	Power which is recovered in regenerative operation of the motors
<b>Braking resistor</b>	For input power in regenerative operation (converted into heat)
<b>CLOSED LOOP</b>	Closed control loop (automatically regulated operation) in which the device being regulated is monitored using a measuring system and made available to the drive
<b>Control cabinet adapter</b>	Spacer bolts used to even out different unit depths
<b>Control unit</b>	The part of the drive unit comprising all the control functions and interfaces for installation in the power unit
<b>Converter</b>	Takes the mains voltage with its fixed amplitude and frequency and generates a three-phase alternating current with variable amplitude and frequency
<b>DC bus capacitor</b>	Optional auxiliary component used to increase the storable DC bus energy
<b>DC bus voltage</b>	DC voltage generated from the AC network and used to supply the power units; also serves as buffer storage for energy
<b>Derating</b>	Lowering of the specified data in the event of a change in operating conditions
<b>Drive control unit</b>	Converter or inverter, consisting of a power unit and a control unit, used to control servo or standard motors
<b>EMC</b>	Electromagnetic compatibility
<b>Feedback cable</b>	Cable used to connect the motor encoder to the feedback interface of the control unit
<b>Firmware</b>	Device-specific software for the drive functions
<b>Functions library</b>	Collection of function blocks conforming to IEC or PLCopen
<b>IndraDrive C</b>	Compact drive series, converter
<b>IndraDrive M</b>	Modular drive series, inverter and power supply units
<b>IndraDyn A</b>	Air-cooled or liquid-cooled asynchronous servo motors
<b>IndraDyn H</b>	High-speed frameless (kit) motors
<b>IndraDyn L</b>	Synchronous linear motors
<b>IndraDyn S</b>	Synchronous servo motors, also for potentially explosive areas
<b>IndraDyn T</b>	Synchronous frameless (kit) torque motors
<b>IndraMotion MLD</b>	Integrated automation solution comprising drive functions, motion control and processing logic
<b>IndraSize</b>	Software tool used for sizing and selecting drives based on the machine data
<b>IndraWorks</b>	Engineering software toolkit for project planning, parameterization, start-up, diagnostics, etc.
<b>Inverter</b>	Takes the DC bus voltage and generates a three-phase alternating current with variable amplitude and frequency

<b>L</b>	<b>Line filter</b>	EMC filters for power supply units and converters used to reduce circuit feedback
	<b>Line regeneration</b>	Recirculation of the energy into the supply network during regenerative operation of the drive
<b>M</b>	<b>Module bus</b>	Bus connection between power units for exchanging internal control signals
	<b>Module bus extension</b>	Optional bus connection used to bridge larger than average distances between individual drive control units
	<b>Motion Logic</b>	Integrated automation solution comprising drive functions, motion control and processing logic
	<b>Motor filter</b>	Used to protect the motor winding from extreme voltage rises
	<b>OPEN LOOP</b>	Open control loop (controlled operation) in which the device being controlled is not monitored using measuring techniques
<b>P</b>	<b>Power cable</b>	Cable for connecting the motor to the power unit
	<b>Power choke</b>	Used to increase the continuous DC bus output and to suppress harmonics
	<b>Power supply unit</b>	Takes the mains voltage with fixed amplitude and frequency and generates a DC bus voltage
	<b>Power unit</b>	The part of the drive control unit containing the power electronics to control the motors, used to hold the control unit
	<b>Safety on Board</b>	Safety technology integrated in the drive, certified as complying with EN 954-1, Category 3
	<b>Shield connection</b>	Connection plate for EMC-compatible connection of the motor cable to the drive control unit
	<b>Software module</b>	MultiMediaCard for simple transmission of axis-oriented drive parameters without the use of a PC

	<b>Switching frequency</b>	Clock frequency of the pulse width modulation (PWM)
<b>T</b>	<b>Technology package</b>	Process-oriented function blocks, e.g. tension control
<b>U</b>	<b>User library</b>	Collection of function blocks developed by the user
	<b>User program</b>	Application-specific combination of different function blocks / technology packages

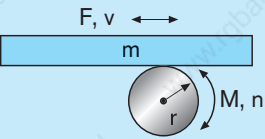
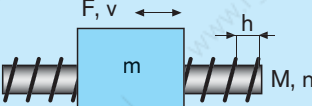
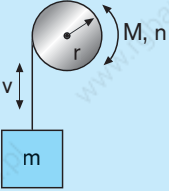
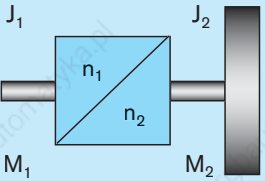

# Formulas

	Speed	Torque	Output	Mass moment of inertia
<b>Roller, wheel and pinion drive</b> 	$n = \frac{v}{2 \cdot r \cdot \pi}$	$M = F \cdot r$	$P = \frac{F \cdot v}{60}$	$J = m \cdot r^2$
<b>Ball screw drive</b> 	$n = \frac{v \cdot 1000}{h}$	$M = \frac{F \cdot h}{2 \cdot \pi \cdot 1000}$	$P = \frac{F \cdot v}{60}$	$J = m \cdot \left( \frac{h}{2 \cdot \pi \cdot 1000} \right)^2$
<b>Pulley drive</b> 	$n = \frac{v}{2 \cdot \pi \cdot r}$	$M = m \cdot g \cdot r$	$P = \frac{m \cdot g \cdot v}{60}$	$J = m \cdot r^2$
	Speed	Torque	Transmission ratio	Mass moment of inertia
<b>Gear conversion</b> 	$n_1 = n_2 \cdot i$	$M_1 = \frac{M_2}{i}$	$i = \frac{n_1}{n_2}$	$J_1 = \frac{J_2}{i^2}$

Miscellaneous			
Rotational frequency	$\omega = \frac{2 \cdot \pi \cdot n}{60}$	Effective electrical power	$P = U \cdot I \cdot \cos\varphi \cdot \sqrt{3}$
Rotational kinetic energy	$W = \frac{J}{2} \cdot \omega^2$	Apparent electrical power	$S = U \cdot I \cdot \sqrt{3}$
Translational kinetic energy	$W = \frac{m}{2} \cdot \left(\frac{v}{60}\right)^2$	Reactive electrical power	$Q = U \cdot I \cdot \sin\varphi \cdot \sqrt{3}$
Synchronous rpm	$n = \frac{f \cdot 60}{p}$	DC bus voltage	$U = U_{\text{Netz}} \cdot \sqrt{2}$
Synchronous speed	$v = 2 \cdot f \cdot \tau_p$	Force	$F = m \cdot a$

Unit conversion			
Physical value	Name of unit	Conversion	Name of unit
force	pound-force	1 lbf = 4.4482 N	Newton
power	horsepower	1 hp = 745.7 W	watt
length	inch	1 in = 25.4 mm	millimeter
length	foot	1 ft = 0.3048 m	meter
mass	pound	1 lb = 0.4536 kg	kilogram

Legend		
a – Acceleration [ms <sup>-2</sup> ]	J – Mass moment of inertia [kgm <sup>2</sup> ]	r – Radius [m]
F – Force [N]	M – Torque [Nm]	S – Apparent power [VA]
f – Frequency [s <sup>-1</sup> ]	m – Mass [kg]	U – Voltage [V]
g – Gravitational acceleration [9.81 ms <sup>-2</sup> ]	n – Rotational speed [rpm]	v – Speed [m/min]
h – Spindle pitch [mm]	P – Power [W]	W – Energy [Ws]
I – Current [A]	p – Pole pair number	$\tau_p$ – Pole pitch
i – Transmission ratio	Q – Reactive power [var]	$\omega$ – Rotational frequency [s <sup>-1</sup> ]

# Documentation and further information

We can supply further information about IndraDrive and IndraDyn as a hard copy, on CD-ROM, DVD or on the Internet.

Alternatively you can contact your local Rexroth distribution agency directly. The relevant address can be found on the back cover of this document.



**Inverter  
IndraDrive M  
Project Planning  
Manual**  
R911295013/DE  
R911295014/EN



**Safety technology  
Application  
instructions**  
R911297837/DE  
R911297838/EN



**Power supply units  
IndraDrive M  
Project Planning  
Manual**  
R911299228/DE  
R911299229/EN



**IndraMotion MLD  
Application  
instructions**  
R911306071/DE  
R911306084/EN

## Documentation – hard copy



**Drive system  
IndraDrive Project  
Planning Manual**  
R911309635/DE  
R911309636/EN



**IndraDrive  
control units  
Project Planning  
Manual**  
R911295011/DE  
R911295012/EN



**IndraLogic  
Programming  
instructions**  
R911305035/DE  
R911305036/EN



**Converter HCS02  
IndraDrive C Project  
Planning Manual**  
R911306137/DE  
R911306138/EN



**Firmware  
Theory of operation**  
R911299224/DE  
R911299225/EN



**Auxiliary components  
Project Planning  
Manual**  
R911306139/DE  
R911306140/EN



**Converter HCS03  
IndraDrive C Project  
Planning Manual**  
R911307048/DE  
R911307049/EN



**Firmware  
Parameter  
description**  
R911297316/DE  
R911297317/EN



**Troubleshooting  
information**  
R911297318/DE  
R911297319/EN



IndraDyn S  
Project Planning  
Manual  
R911296288/DE  
R911296289/EN



GTE gearboxes  
Project Planning  
Manual  
R911308841/DE  
R911308842/EN



IndraDyn A  
Project Planning  
Manual  
R911295054/DE  
R911295781/EN



GTM gearboxes  
Project Planning  
Manual  
R911297320/DE  
R911297321/EN



IndraDyn L  
Project Planning  
Manual  
R911293634/DE  
R911293635/EN



Connection cables  
Selection data  
R911280894/DE  
R911280897/EN



IndraDyn H  
Project Planning  
Manual  
R911297894/DE  
R911297895/EN



IndraDyn T  
Project Planning  
Manual  
R911291224/DE  
R911298798/EN

### Documentation on CD/DVD

The complete documentation for IndraDrive and IndraDyn on CD-ROM or DVD.



R911306531/DE  
and EN

### Documentation online

All current documentation can also be downloaded at [www.boschrexroth.com/brcdoku](http://www.boschrexroth.com/brcdoku)

### Download IndraSize

IndraSize – the drive sizing program can be downloaded at [www.boschrexroth.com/indrasize](http://www.boschrexroth.com/indrasize)

### Rexroth online

Information about Bosch Rexroth AG and our products and system solutions can be found by visiting [www.boschrexroth.com](http://www.boschrexroth.com)

Bosch Rexroth Corporation  
Corporate Headquarters  
5150 Prairie Stone Parkway  
Hoffman Estates, IL 60192-3707  
Telephone (847) 645-3600  
Facsimile (847) 645-6201  
www.boschrexroth-us.com

#### International offices:

##### Asia:

China	Russia
India	Singapore
Japan	South Korea
Malaysia	

##### Australia

##### Europe:

Austria	Norway
Belgium	Poland
Bulgaria	Portugal
Czech Republic	Romania
Denmark	Slovakia
Finland	Spain
France	Sweden
Germany	Switzerland
Greece	Turkey
Hungary	Ukraine
Italy	United Kingdom
Netherlands	

##### North America:

Canada	United States
Mexico	

##### South America:

Argentina	Venezuela
Brazil	

#### Regional sales offices:

##### Central

Bosch Rexroth Corporation  
Electric Drives and Controls  
2150 Point Boulevard, Ste 800  
Elgin, IL 60123  
Telephone (224) 293-3551  
Facsimile (847) 551-9812

##### Great Lakes

Bosch Rexroth Corporation  
Electric Drives and Controls  
1701 Harmon Road  
Auburn Hills, MI 48326-1549  
Telephone (248) 393-3330  
Facsimile (248) 393-2893

##### Northeast

Bosch Rexroth Corporation  
Electric Drives and Controls  
99 Rainbow Road  
East Granby, CT 06026-0000  
Telephone (860) 844-8377  
Facsimile (860) 844-8595

##### Southeast

Bosch Rexroth Corporation  
Electric Drives and Controls  
2810 Premiere Parkway  
Duluth, GA 30097  
Telephone (678) 957-4050  
Facsimile (678) 417-6637

##### West

Bosch Rexroth Corporation  
Electric Drives and Controls  
7901 Stoneridge Drive, Suite 220  
Pleasanton, CA 94588  
Telephone (925) 227-1074  
Facsimile (925) 227-1081

#### U.S. technology groups:

Bosch Rexroth Corporation  
Industrial Hydraulics  
2315 City Line Road  
Bethlehem, PA 18017-2131  
Telephone (610) 694-8300  
Facsimile (610) 694-8467

Bosch Rexroth Corporation  
Electric Drives and Controls  
5150 Prairie Stone Parkway  
Hoffman Estates, IL 60192-3707  
Telephone (847) 645-3600  
Facsimile (847) 645-6201

Bosch Rexroth Corporation  
Linear Motion and  
Assembly Technologies  
816 E. Third Street  
Buchanan, MI 49107  
Telephone (269) 695-0151  
Facsimile (269) 695-5363

14001 South Lakes Drive  
Charlotte, NC 28273  
Telephone (800) 438-5983  
Facsimile (704) 583-0523

Bosch Rexroth Corporation  
Pneumatics  
1953 Mercer Road  
Lexington, KY 40511-1021  
Telephone (859) 254-8031  
Facsimile (859) 254-4188

Bosch Rexroth Corporation  
Service  
5150 Prairie Stone Parkway  
Hoffman Estates, IL 60192-3707  
Telephone (847) 645-3600  
Facsimile (847) 645-0804

2315 City Line Road  
Bethlehem, PA 18017-2131  
Telephone (610) 694-8300  
Facsimile (610) 694-8467

Bosch Rexroth Corporation  
Mobile Hydraulics  
145 Southchase Boulevard  
Fountain Inn, SC 29644-9018  
Telephone (864) 967-2777  
Facsimile (864) 962-5338