

Figure 2. Requirements for pulsed output signals from a primary safety device



**WARNING: Not for use as a stand-alone safety module.**

1. DO NOT connect E-stop switches, 2-hand control actuators/switches, safety interlock switches, or similar devices directly to this Interface Module.
2. ALWAYS connect terminals Y1-Y2 and Y3-Y4 of this Interface Module to the monitoring input of the primary safety device that controls it.

This Module does not have the circuitry required to perform a self-check. A single fault inside the unit or in external devices (like switches or E-stop buttons) can go undetected and create an unsafe condition. Failure to properly connect this Interface Module to a primary safety device with a monitoring function could result in serious injury or death.

## Mechanical Installation

The Safety Module must be installed inside an enclosure.

It is not designed for exposed wiring. It is the user's responsibility to house the Safety Module in an enclosure with NEMA 3 (IEC IP54) rating, or better. The Safety Module mounts directly to standard 35 mm DIN rail.

**Heat Dissipation Considerations.** For reliable operation, ensure that the operating specifications are not exceeded. The enclosure must provide adequate heat dissipation, so that the air closely surrounding the Module does not exceed the maximum operating temperature stated in the Specifications. Methods to reduce heat build-up include venting, forced airflow (e.g., exhaust fans), adequate enclosure exterior surface area, and spacing between modules and other sources of heat.

## Electrical Installation



**CAUTION: Shock Hazard**

Always disconnect power from the Banner device and the guarded machine before making any connections or replacing any component. Electrical installation and wiring must be made by qualified personnel and must comply with the NEC (National Electrical Code), ANSI NFPA79 or IEC 60204-1 and -2, and all applicable local standards and codes. **Use extreme caution to avoid electrical shock at all times. Serious bodily injury or death could result.**



**WARNING: Safety Categories**

The level of safety circuit integrity can be greatly impacted by the design and installation of the safety devices and the means of interfacing of those devices. **A risk assessment must be performed to determine the appropriate safety circuit integrity level or safety category as described by ISO 13849-1 (EN 954-1) to ensure that the expected risk reduction is achieved and that all relevant regulations and standards are complied with.**



**CAUTION:** When FSD1 switches +24V dc and FSD2 switches 0V dc (Figures 4 and 5), a short circuit between the wires leading to S1, S2, S3 and S4 is detected immediately and K1 and K2 de-energize. However, a short circuit can result in a high current through the FSD1 and FSD2 contacts, so the current coming from the 24V dc supply connected to FSD1 and FSD2 must be fused or limited to 6 amps max. Otherwise, damage to the primary safety device may result.

It is not possible to give exact wiring instructions for a Safety Module that interfaces to a multitude of machine control configurations. The following guidelines are general in nature.

The Safety Module has no delay function. Its output relay contacts open within **20 milliseconds** after a safety input opens. This classifies the Safety Module as functional stop "Category 0" control, as defined by ANSI NFPA 79 and IEC/EN 60204-1.

The inputs can be connected to (that meet the requirements for primary safety device above):

- A +24V dc solid-state (PNP) outputs in single-channel or dual-channel hookup configuration, or
- A +24V/0V dc source that is switched by hard/relay contacts in single-channel or dual-channel hookup configuration.

The dual-channel hookup configuration allows the primary safety device to detect certain failures and faults, such as short circuits, that could result in a loss of the safety function. Two-channel control should be used whenever unsafe failure of the control wires cannot be eliminated. The first circuit shown below can meet ISO 13849-1 Category 2, 3, or 4 requirements, depending on the safety rating and the installation of the primary safety device.

The outputs of the primary safety device must, at minimum, comply with the requirements described. These outputs must be monitored for failure by the primary safety device. In addition, a single output failure cannot prevent normal stopping action, and a successive cycle cannot be initiated until the failure has been corrected.

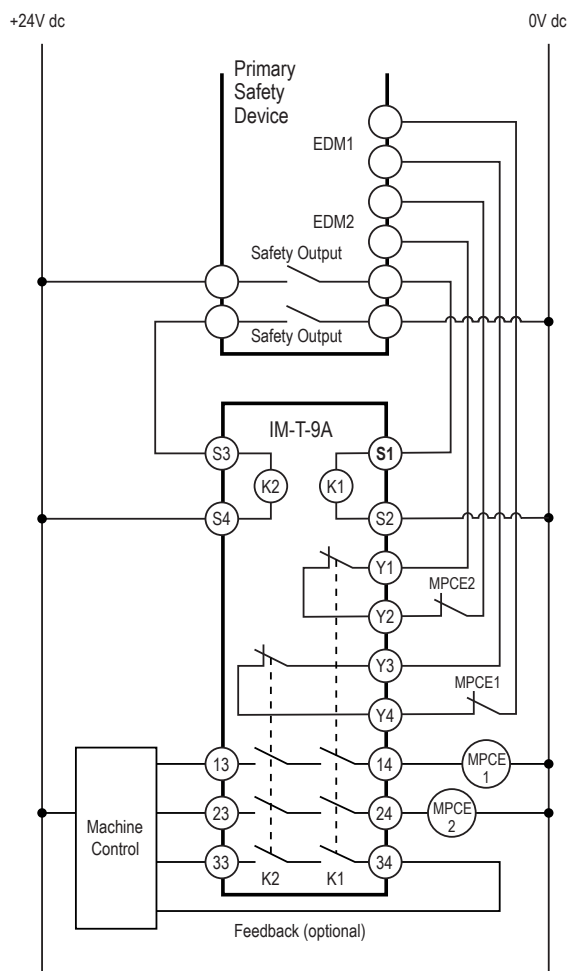

**Figure 3. Generalized hookup to a 2-channel primary safety device with two hard-contact safety outputs (FSD1 and FSD2) and two monitoring inputs.**

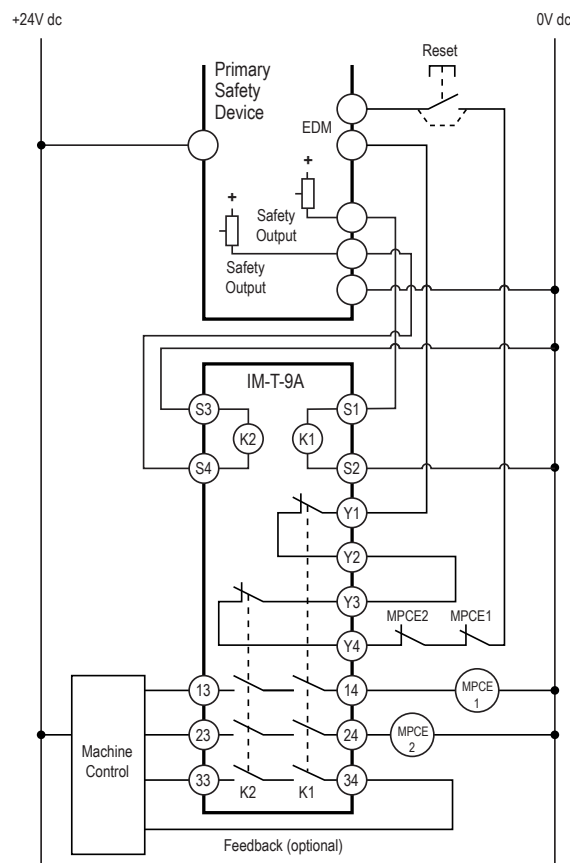

**Figure 4. Generalized hookup to a 2-channel primary safety device with two hard-contact safety outputs and one monitoring contact feedback input.**

Although this hookup shows model IM-T-9A, the hookup for model IM-T-11A is identical.