

# MAGELiS® Operator Terminals

## Alphanumeric Matrix Graphic

Class 9001



### CONTENTS

Description	Page
Product Description .....	3
XBTH/P/E/HM/PM Display Units and Terminals .....	8
XBTH Display Units with 2 Line Alphanumeric Screen .....	10
XBTP Terminals with 2 Line Alphanumeric Screen .....	12
XBTE Terminals with 2 or 4 Line Alphanumeric Screen .....	14
XBTHM/PM Display Units with 8 Line Matrix Screen .....	16
XBTF Terminals with Graphic Screen .....	18
Development Software .....	30
Separate Parts .....	34
XBTF Bus and Network Connections .....	36
Wiring Diagrams .....	39
Dimensions .....	51

-  **Merlin Gerin**
-  **Modicon**
-  **Square D**
-  **Telemecanique**

Schneider Electric Brands



**SQUARE D**  
Schneider Electric



# MAGELiS® Operator Terminals

## Product Description

### General

The MAGELiS operator terminals come with the following features:





- Alphanumeric LCD or fluorescent displays
- 5- or 10-inch size
- Graphical matrix display
- Monochrome or color screen
- Touch sensitive types
- Configuration software based on the Microsoft® Windows programming environment
- All terminals are programmable using the same software package and the same configuration procedure
- Graphics terminals use a symbols library that allows the programmer to develop customized, animated screens
- Many different protocols are supported that allow communication with a wide variety of programmable controllers

*NOTE: A bullet (•) in the catalog number denotes a character that can vary.*





# MAGELiS® Operator Terminals

## Product Description

Terminals	Display Units with Alphanumeric Screen	Terminals with Alphanumeric Screen		Display Units with Matrix Screen
				
<b>Display Type</b>	Fluorescent green matrix (5 x 7 pixels), height 0.2 in. (5 mm) or Back-lit LCD (5 x 7 pixels), height 0.35 in. (9 mm)	Fluorescent green matrix (5 x 7 pixels), height 0.2 in. (5 mm) or Back-lit LCD (5 x 7 pixels), height 0.2 in. (5 mm)	Fluorescent green matrix (5 x 7 pixels), height 0.2 in. (5 mm) or Back-lit LCD (5 x 7 pixels), height 0.2 in. (5 mm)	Back-lit monochrome matrix LCD (240 x 64 pixels) height 0.21 or 0.42 in. (5.3 or 10.6 mm)
<b>Capacity</b>	2 lines of 20 characters	2 or 4 lines of 40 characters	2 or 4 lines of 40 characters	4 to 8 lines of 20 to 40 characters
<b>Data Entry</b>	Display only or Via keypad with — 4 function keys — 1 or 5 service keys	Via keypad with — 8 function keys — 9 service keys or — 12 function keys — 10 service keys — 12 numeric keys	Via keypad with — 24 function keys — 10 service keys — 12 alphanumeric keys	Display only or Via keypad with — 4 function keys — 1 or 5 service keys
<b>Memory Capacity Application</b>	128 KB/256 KB Flash EEPROM	256 KB Flash EEPROM	384 KB Flash EEPROM	
<b>Extension via PCMCIA Type II</b>	—			
<b>Functions</b>				
<b>Maximum Number of Pages</b>	100/200 application pages 128/256 alarm pages	400 application pages 256 alarm pages	800 applications pages 256 alarm pages	600 application pages 256 alarm pages
<b>Variables per Page</b>	50			
<b>Representation of the Variables</b>	Alphanumeric			Alphanumeric, bargraph, gauge
<b>Recipes</b>	—			
<b>Curves</b>	—			
<b>Alarm Logs</b>	Dependent on the model			
<b>Real-Time Clock</b>	Access to the PLC real-time clock		Built-in	Access to the PLC real-time clock
<b>Alarm Relay</b>	No		Yes	No
<b>Communication Asynchronous Serial Port</b>	RS 232 C / RS 485 / RS 422			
<b>Downloadable Protocols</b>	UNI-TELWAY, MODBUS®, AEG and for Allen Bradley, GE Fanuc, Omron, Siemens brand PLCs			
<b>Buses and Networks</b>	AS-i with module at 22.5 intervals	—		AS-i with module at 22.5 intervals
<b>Printer Port</b>	RS 232 C asynchronous serial link (dependent on the model)			
<b>Development Software</b>	XBTL1000/L1003/L1004 (under Windows 3.1 or Windows 95)			XBTL1003/L1004 (under Windows 95 and Windows NT 4.0)
<b>Operating Systems</b>	MAGELiS			
<b>Type of Terminal</b>	XBTH	XBTP	XBTE	XBTHM
<b>Page</b>	10	12	14	16

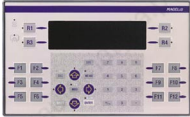

# MAGELiS® Operator Terminals Product Description

Terminals	Display Units with matrix screen	Terminals with graphic screen			
					
<b>Display Type</b>	Back-lit monochrome matrix LCD (240 x 64 pixels) height 0.21 or 0.42 in. (5.3 or 10.6 mm)	Back-lit monochrome LCD (320 x 240 pixels) or Color LCD STN with touch-sensitive screen (320 x 240 pixels)		Back-lit monochrome LCD (640 x 480 pixels) or Back-lit color TFT LCD (640 x 480 pixels)	
<b>Capacity</b>	4 to 8 lines of 20 to 40 characters	5.7 in. (145 mm)		9.5 in. (241 mm) monochrome (XBTF02 only) 10.4 in. (264 mm) color	
<b>Data Entry</b>	Via keypad with — 12 function keys — 10 service keys — 12 numeric keys — 4 dynamic function keys	Via touch-sensitive screen with 4 touch-sensitive keys (XBTF02) Touch 'n Click	Via keypad with — 10 static function keys — 8 dynamic function keys — 12 service keys — 12 alphanumeric keys	Via touch-sensitive screen with 8, 12, or 16 touch-sensitive keys <sup>(1)</sup> (XBTF02) Touch 'n Click	Via keypad with — 12 static function keys — 10 dynamic function keys — 12 service keys — 12 alphanumeric keys
<b>Memory Capacity Application</b>	5120 KB Flash EEPROM	8 MB Flash EEPROM (using Type II PCMCIA card)			
<b>Extension via PCMCIA Type II</b>	—	8 MB or 16 MB			
<b>Functions Maximum Number of Pages</b>	800 application pages 256 alarm pages 256 printout form pages <sup>(1)</sup>	50 to 720 application, alarm, help, and printout form pages, depending on the memory card used (512 alarms max)		30 to 480 application, alarm, help, and printout form pages, depending on the memory card used (512 alarms max)	
<b>Variables per Page</b>	50	64			
<b>Representation of the Variables</b>	Alphanumeric, bargraph, gauge	Alphanumeric, bitmap, bargraph, gauge, potentiometer, selector			
<b>Recipes</b>	—	Maximum 125 records with maximum 5000 values			
<b>Curves</b>	—	16			
<b>Alarm Logs</b>	Dependent on the model	Yes			
<b>Real-time Clock</b>	Access to the PLC real-time clock				
<b>Alarm Relay</b>	No	Yes			
<b>Communication Asynchronous Serial Port</b>	RS 232 C / RS 485 / RS 422				
<b>Downloadable Protocols</b>	UNI-TELWAY, MODBUS, AEG and for Allen Bradley, GE Fanuc, Omron, and Siemens brand PLCs				
<b>Buses and Networks</b>	AS-i with module	MODBUS Plus, FIPIO®/FIPWAY® with optional Type III PCMCIA card			
<b>Printer Port</b>	RS 232 C asynchronous serial link (dependent on the model)				
<b>Development Software</b>	XBTL1000/L1003/L1004	XBTL1003/L1004 (under Windows 95 and NT 4.x)			
<b>Operating Systems</b>	MAGELiS				
<b>Type of Terminal</b>	XBTPM	XBTF01/F03/FC		XBTF02/F03/FC	
<b>Page</b>	17	22, 26		22, 26	

<sup>(1)</sup> Dependent on the model.



# MAGELiS® Operator Terminals

## Product Description

### Architectures, connections to control systems

MAGELiS operator dialogue terminals communicate with control system equipment:

- Via serial link
- Via fieldbus
- In network architectures

### Point-to-point or multidrop connection with the PLC via serial link

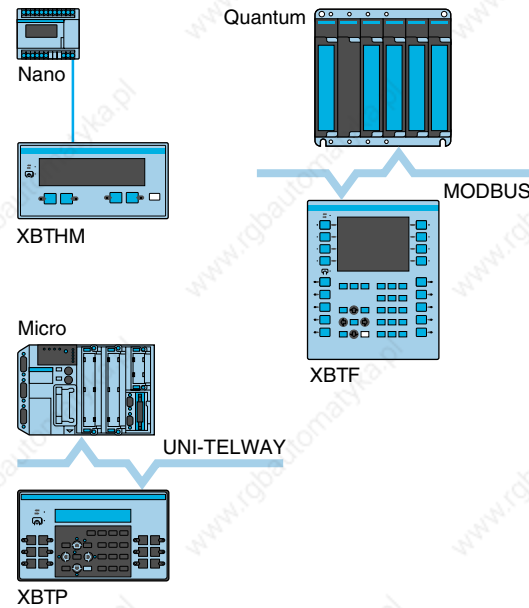

All terminals incorporate an RS 232 C, RS 422/485 asynchronous serial link as standard.

The use of a UNI-TELWAY, MODBUS, or KS protocol means that communication can be set up easily with Schneider Electric PLCs: TSX, MODICON®, April, or A-Line.

Third-party protocols provide connection to PLCs offered by the main market suppliers:

- DF1, DH485 for Allen Bradley PLC5/SLC500 PLCs
- SNPX for General Electric Series 90 PLCs
- Sysway for Omron C200 PLCs
- AS511/3964R, MPI/PPI for Siemens Simatic S5/S7 PLCs

### Connection to PLCs via fieldbus

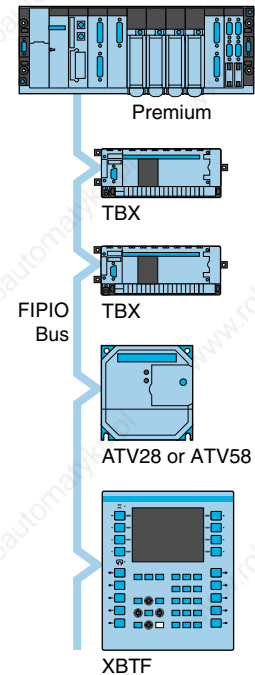

The addition of a Type III PCMCIA communication card to XBT terminals with graphic screen enables connection to various industrial networks:

- FIPIO
- MODBUS Plus

XBT terminals with a graphic screen use the bus master PLC to provide operator dialogue and interactive control of various devices connected on the bus.

Several terminals with a graphic screen can be connected on the same bus.



# MAGELiS® Operator Terminals Product Description

## Connection to network architectures

The addition of a Type III PCMCIA communication card to XBTF terminals with a graphic screen means that they can be integrated into single or multiple network architectures:

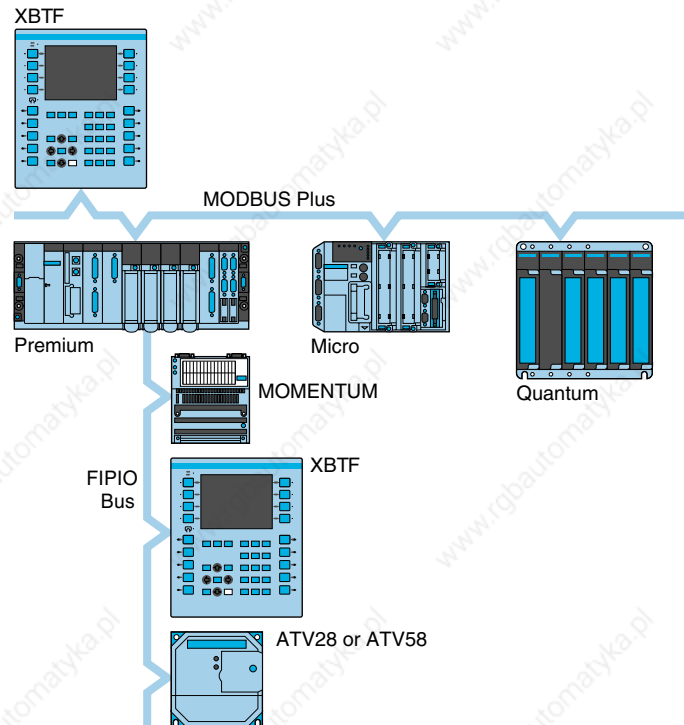

- FIPWAY network
- MODBUS Plus network



# MAGELiS® Operator Terminals

## XBTH/P/E/HM/PM Display Units and Terminals

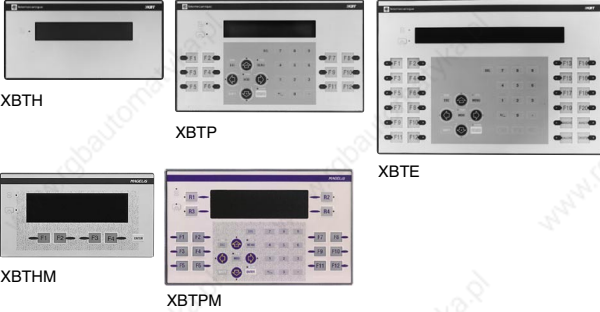
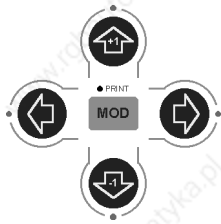
### General

<p><b>Presentation</b></p>	 <p>XBTH</p> <p>XBTP</p> <p>XBTE</p> <p>XBTHM</p> <p>XBTPM</p>	<p>XBTH/P/E display units and terminals with alphanumeric screen are used to represent messages and variables. Various keys can be used to modify variables, control the device, or browse in a dialogue application.</p> <p>XBTHM/PM terminals with matrix screen can also be used to display bitmap images and animated bar chart and gauge objects.</p>
<p><b>Operation</b></p>		<p>All the MAGELiS display units and terminals with alphanumeric and matrix screens have the same user interface: function keys, service keys, and numeric or alphanumeric keys.</p>
<p><b>Configuration</b></p>		<p>MAGELiS display units and terminals can be configured using the same XBTL100* software in a Windows environment.</p> <p>For terminals with an alphanumeric screen, XBTL100* software employs pages. Each page can be viewed in its entirety. Selecting a line of text shows what will appear on the product screen (two to four lines, depending on the model).</p> <p>For XBTHM terminals with a matrix screen, XBTL100* software offers up to 8 lines of 40 characters, and animated bar chart and gauge objects.</p>
<p><b>Communication</b></p>	 <p>XBTH</p> <p>PLC</p>	<p>XBTH/P/E/HM/PM terminals communicate with PLCs via an integrated point-to-point or multidrop serial link.</p> <p>The communication protocols used are those of Schneider PLCs as well as those of the other main market suppliers.</p>

### Functions

Depending on the model, XBTH/P/E/HM/PM display units and terminals have function keys and service keys on the front panel.

#### Function Keys

Function keys are defined for the whole application. They can be used for accessing a page, pulse control, and toggle set/reset.

#### Service Keys

Service keys are the arrow keys and the control keys combined. Service keys are used to modify the parameters of the control system.



# MAGELiS® Operator Terminals XBTH/P/E/HM/PM Display Units and Terminals

The control keys are used to perform the following actions:

- ENTER** Confirm a selection or entry, acknowledge an alarm
- MOD** Change to the mode for entering pages, passwords, fields, or graphic objects
- ESC** Cancel an entry, suspend or stop a current action
- SHIFT** Access the second of the dual key functions
- MENU** Access a menu containing the operating functions
- HOME** Return to the entry point of the current menu  
Example: return to the first page of the application
- SYST** Access the confidential mode, which contains the implementation functions
- ALARM** View the alarms
- PRINT** Print



The arrow keys are used to:

- Change page within a menu
- Move within a page
- Select the value of a digit
- Select a value from a list of choices
- When used with the **SHIFT** key, increment or decrement the value of a variable field

## Description

XBTH/P/E/HM/PM display units and terminals include:



On the front panel:

1. A communication monitoring indicator lamp
2. A keypad activity indicator lamp (dependent on the model)
3. Fluorescent or LCD back-lit display
4. Function keys with indicator lamp and reusable labels
5. Service keys with indicator lamp
6. Twelve numeric keys (for XBTP02\*\*\*\*)  
Twelve alphanumeric keys [0 to 9, (+/-), (.)] associated with three alphabetical access keys (A to Z) for XBTE

On the rear:



1. A plug-in terminal block for 24 Vdc power supply and a connection for the alarm relay (dependent on the model)
2. A female 25-pin SUB-D connector for connection to PLCs, FTX configuration terminals, or PC compatibles
3. A male 9-pin SUB-D connector for the printer connection (dependent on the model)



# MAGELiS® Operator Terminals

## XBTH Display Units with 2 Line Alphanumeric Screen

### Selection

#### Display Units with 2 Lines of 20 Characters (Fluorescent)



XBTH02\*010

Downloadable Exchange Protocol	Number of Keys			Supply Voltage (VDC)	Language Version	Catalog Number	Weight lbs (kg)
	Function	Service	Alphanumeric				
<b>No Printer Port, No Log</b>							
See page 34	—	—	—	24	Multilingual	XBTH002010	1.3 (0.6)
	4	1	—	24	Multilingual	XBTH022010	1.3 (0.6)
	—	5	—	24	Multilingual	XBTH012010	1.3 (0.6)
<b>With Printer Port and Log</b>							
See page 34	—	5	—	24	Multilingual	XBTH012110	1.3 (0.6)

#### Display Units with 2 Lines of 20 Characters (LCD)



XBTH01\*\*10

Downloadable Exchange Protocol	Number of Keys			Supply Voltage (VDC)	Language Version	Catalog Number	Weight lbs (kg)
	Function	Service	Alphanumeric				
<b>No Printer Port, No Log</b>							
UNI-TELWAY See page 34	—	5	—	24 and 5 via terminal socket on the TSX Nano/Micro/Premium PLC	Multilingual	XBTH811050	1.3 (0.6)

#### Display Units with 2 Lines of 20 Characters (Back-Lit LCD)



XBTH00\*010

Downloadable Exchange Protocol	Number of Keys			Supply Voltage (VDC)	Language Version	Catalog Number	Weight lbs (kg)
	Function	Service	Alphanumeric				
<b>No Printer Port, No Log</b>							
See page 34	—	—	—	24	Multilingual	XBTH001010	1.3 (0.6)
	4	1	—	24	Multilingual	XBTH021010	1.3 (0.6)
	—	5	—	24	Multilingual	XBTH011010	1.3 (0.6)

#### Separate Parts

Description	Use	Catalog Number	Weight lbs (kg)
Development Software	Under Windows 3.1 or 95, for downloading the application and protocols	See page 33	—
Connecting Cables	Connection to PLCs, configuration terminals, etc.	See page 34	—

#### Documentation

Description	Format	Included in the Product	Catalog Number ▲	Weight lbs (kg)
MAGELiS User's Manual	A5 Bound (148 x 210 mm, approx. 6 x 8.25 in)	XBTL1003* and XBTL1004*	XBTX000**	0.4 (0.2)

▲ Add the following suffixes **EN**: English, **FR**: French, **DE**: German, **ES**: Spanish, **IT**: Italian.



# MAGELiS® Operator Terminals

## XBTH Display Units with 2 Line Alphanumeric Screen

### Specifications

Type of Display Unit	XBTH0•2•10 (Fluorescent)	XBTH811050 (LCD)	XBTH0•1010 (Back-Lit LCD)					
<b>Environment</b>								
<b>Conforming to Standards</b>	IEC 61131-2, IEC 60068-2-6, IEC 60068-2-27, EN 61131-2, UL 508, CSA C22-2 No. 142							
<b>Product Certifications</b>	CE, UL, CSA, UL E164866, CCN: NRAQ, CSA LR 44087, Class 2252 01							
<b>Temperature</b>	Operation	+32 to +122 °F (0 to +50 °C)						
	Storage	-40 to +158 °F (-40 to +70 °C)	-4 to +140 °F (-20 to +60 °C)					
<b>Degree of Protection</b>	IP 65, conforming to IEC 60529, NEMA Type 4, UL Type 4							
<b>Mechanical Characteristics</b>								
<b>Mounting and Fixing</b>	Flush-mounted, fixed with 4 or 6 screws (supplied), pressure-mounted on a panel of thickness 0.04–0.24 in. (1–6 mm)							
<b>Material</b>	Enclosure	Polyphenyl oxide, 10% glass fiber (PPO GFN1 SE1)						
	Keypad	Anti-UV treated toughened polyester (Autoflex EB AG)						
<b>Keys</b>		<b>XBTH002 010</b>	<b>XBTH022 010</b>	<b>XBTH012 •10</b>	<b>XBTH811050</b>	<b>XBTH001 010</b>	<b>XBTH021 010</b>	<b>XBTH011 010</b>
		No keys	4 function keys 1 service key	5 service keys	5 service keys	No key	4 function keys 1 service key	5 service keys
<b>Electrical Characteristics</b>								
<b>Display Unit</b>	Fluorescent green matrix characters (5 x 7 pixels) 2 lines of 20 characters, height 0.2 in. (5 mm)	LCD (5 x 7 pixels) 2 lines of 20 characters, height 0.35 in. (9 mm)	Back-lit LCD (5 x 7 pixels) 2 lines of 20 characters, height 0.35 in. (9 mm)					
<b>Power Supply</b>	Voltage	24 Vdc not isolated	<b>During configuration:</b> 24 Vdc not isolated <b>During operation:</b> 5 Vdc via TSX Nano/Micro/Premium PLC terminal port	24 Vdc not isolated				
	Voltage Limits	18–30 V						
	Ripple	5% maximum						
<b>Consumption</b>	10 W	1.5 W	10 W					
<b>Operating Characteristics</b>								
<b>Signaling</b>		<b>XBTH002 010</b>	<b>XBTH022 010</b>	<b>XBTH012 •10</b>	<b>XBTH811050</b>	<b>XBTH001 010</b>	<b>XBTH021 010</b>	<b>XBTH011 010</b>
		1 LED	6 LEDs	4 LEDs	—	1 LED	6 LEDs	4 LEDs
<b>Memory</b>	128 KB Flash EEPROM, 256 KB ( <b>XBTH012110</b> ) 200 application pages approximately (2 lines per page) 256 available alarm pages (2 lines per page)	128 KB Flash EEPROM 100 application pages approximately (2 lines per page) 128 available alarm pages (2 lines per page)	128 KB Flash EEPROM, 256 KB ( <b>XBTH011010</b> ) 200 application pages approximately (2 lines per page) 256 available alarm pages (2 lines per page)					
<b>Log Function</b>	Permits storage of alarm pages ( <b>XBTH012110</b> )	—	—					
<b>Transmission (asynchronous serial link)</b>	RS 232 C / RS 285 / RS 422	RS 232 C / RS 485	RS 232 C / RS 485 / RS 422					
<b>Downloadable Protocol</b>	Multiple (see pages 8 and 34)	UNI-TELWAY (see pages 8 and 34)	Multiple (see page 8 and 34)					
<b>Real-Time Clock</b>	Access to the PLC real-time clock							
<b>Printer Port (asynchronous serial link)</b>	RS 232 C ( <b>XBTH012110</b> )	—	—					
<b>Connection</b>	Power Supply	Plug-in terminal block 3 screw terminals, 13/64" (5.08 mm) pitch Maximum clamping capacity: #16 AWG (1.5 mm <sup>2</sup> ), 0.5–0.6 N•m						
	Serial Port	Female 25-pin SUB-D connector	—	—				
	Printer Port	Male 9-pin SUB-D connector	—	—				



# MAGELiS® Operator Terminals

## XBTP Terminals with 2 Line Alphanumeric Screen

### Selection

#### Terminals with 2 Lines of 20 Characters (Fluorescent)



XBTP01•010

Downloadable Exchange Protocol	Number of Keys			Supply Voltage (VDC)	Language Version	Catalog Number	Weight lbs (kg)
	Function	Service	Alphanumeric				
<b>No Printer Port, No Log</b>							
See page 34	8	9	—	24	Multilingual	XBTP012010	1.8 (0.8)
	12	10	12	24	Multilingual	XBTP022010	1.8 (0.8)
<b>With Printer Port and Log</b>							
See page 34	12	10	12	24	Multilingual	XBTP022110	1.8 (0.8)

#### Terminals with 2 Lines of 20 Characters (Back-Lit LCD)



XBTP02••10

Downloadable Exchange Protocol	Number of Keys			Supply Voltage (VDC)	Language Version	Catalog Number	Weight lbs (kg)
	Function	Service	Alphanumeric				
<b>No Printer Port, No Log</b>							
See page 34	8	9	—	24	Multilingual	XBTP011010	1.8 (0.8)
	12	10	12	24	Multilingual	XBTP021010	1.8 (0.8)
<b>With Printer Port and Log</b>							
See page 34	12	10	12	24	Multilingual	XBTP021110	1.8 (0.8)

#### Separate Parts

Description	Use	Catalog Number	Weight lbs (kg)
Development Software	Under Windows 3.1 or 95, for downloading the application and protocols	See page 33	—
Connecting Cables	Connection to PLCs, configuration terminals, etc.	See page 34	—

#### Documentation

Description	Format	Included in the Product	Catalog Number ▲	Weight lbs (kg)
MAGELiS User's Manual	A5 Bound (148 x 210 mm, approx. 6 x 8.25 in)	XBTL1003• and XBTL1004•	XBTX000••	0.4 (0.2)

▲ Add the following suffixes EN: English, FR: French, DE: German, ES: Spanish, IT: Italian.



# MAGELiS<sup>®</sup> Operator Terminals

## XBTP Terminals with 2 Line Alphanumeric Screen

### Specifications

<b>Type of Terminal</b>	<b>XBTP0•2•10 (Fluorescent)</b>	<b>XBTP0•1•10 (Back-Lit LCD)</b>		
<b>Environment</b>				
<b>Conforming to Standards</b>	IEC 61131-2, IEC 60068-2-6, IEC 60068-2-27, EN 61131-2, UL 508, CSA C22-2 No. 142			
<b>Product Certifications</b>	CE, UL, CSA, UL E164866, CCN: NRAQ, CSA LR 44087, Class 2252 01			
<b>Temperature</b>	Operation	+32 to +122 °F (0 to +50 °C)		
	Storage	-40 to +158 °F (-40 to +70 °C)	-4 to +140 °F (-20 to +60 °C)	
<b>Degree of Protection</b>	IP 65, conforming to IEC 60529, NEMA Type 4, UL Type 4			
<b>Mechanical Characteristics</b>				
<b>Mounting and Fixing</b>	Flush-mounted, fixed with 4 or 6 screws (supplied), pressure-mounted on a panel of thickness 0.04–0.24 in. (1–6 mm)			
<b>Material</b>	Enclosure	Polyphenyl oxide, 10% glass fiber (PPO GFN1 SE1)		
	Keypad	Anti-UV treated toughened polyester (Autoflex EB AG)		
<b>Keys</b>	<b>XBTP012010</b>	<b>XBTP022•10</b>	<b>XBTP011010</b>	<b>XBTP021•10</b>
	8 function keys 9 service keys	12 function keys 10 service keys 12 numeric keys	8 function keys 9 service keys	12 function keys 10 service keys 12 numeric keys
<b>Electrical Characteristics</b>				
<b>Display Unit</b>	Fluorescent green matrix characters (5 x 7 pixels) 2 lines of 20 characters, height 0.20 in. (5 mm)		Back-lit LCD (5 x 7 pixels) 2 lines of 20 characters, height 0.35 in. (9 mm)	
<b>Power Supply</b>	Voltage	24 Vdc not isolated		
	Voltage Limits	18–30 V		
	Ripple	5% maximum		
<b>Consumption</b>	10 W			
<b>Operating Characteristics</b>				
<b>Signaling</b>	<b>XBTP012010</b>	<b>XBTP022•10</b>	<b>XBTP011010</b>	<b>XBTP021•10</b>
	17 LEDs	21 LEDs	17 LEDs	21 LEDs
<b>Memory</b>	256 KB Flash EEPROM 400 application pages approximately (2 lines per page) 256 available alarm pages (2 lines per page)			
<b>Log Function</b>	Permits storage of alarm pages ( <b>XBTP022110</b> )		Permits storage of alarm pages ( <b>XBTP021110</b> )	
<b>Transmission (asynchronous serial link)</b>	RS 232 C / RS 485 / RS 422			
<b>Downloadable Protocol</b>	Multiple (see pages 8 and 34)			
<b>Real-Time Clock</b>	Access to the PLC real-time clock			
<b>Printer Port (asynchronous serial link)</b>	RS 232 C ( <b>XBTP022110</b> )		RS 232 C ( <b>XBTP021110</b> )	
<b>Connection</b>	Power Supply	Plug-in terminal block 3 screw terminals, 13/64" (5.08 mm) pitch Maximum clamping capacity: #16 AWG (1.5 mm <sup>2</sup> ), 0.5–0.6 N•m		
	Serial Port	Female 25-pin SUB-D connector		
	Printer Port	Male 9-pin SUB-D connector		



# MAGELiS® Operator Terminals

## XBTE Terminals with 2 or 4 Line Alphanumeric Screen

### Selection

#### Terminals with 2 Lines of 40 Characters (Fluorescent)

Downloadable Exchange Protocol	Number of Keys			Supply Voltage (VDC)	Language Version	Catalog Number	Weight lbs (kg)
	Function	Service	Alphanumeric				
<b>No Printer Port, No Log</b>							
See page 34	24	10	12	24	Multilingual	XBTE014010	2.2 (1.0)
<b>With Printer Port and Log</b>							
See page 34	24	10	12	24	Multilingual	XBTE014110	2.2 (1.0)



XBTE014\*10

#### Terminals with 4 Lines of 40 Characters (Fluorescent)

Downloadable Exchange Protocol	Number of Keys			Supply Voltage (VDC)	Language Version	Catalog Number	Weight lbs (kg)
	Function	Service	Alphanumeric				
<b>No Printer Port, No Log</b>							
See page 34	24	10	12	24	Multilingual	XBTE016010	2.2 (1.0)
<b>With Printer Port and Log</b>							
See page 34	24	10	12	24	Multilingual	XBTE016110	2.2 (1.0)

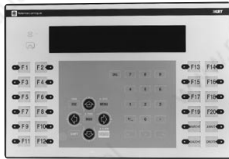

XBTE016\*10

#### Terminals with 2 Lines of 40 Characters (Back-Lit LCD)

Downloadable Exchange Protocol	Number of Keys			Supply Voltage (VDC)	Language Version	Catalog Number	Weight lbs (kg)
	Function	Service	Alphanumeric				
<b>No Printer Port, No Log</b>							
See page 34	24	10	12	24	Multilingual	XBTE013010	2.2 (1.0)
<b>With Printer Port and Log</b>							
See page 34	24	10	12	24	Multilingual	XBTE013110	2.2 (1.0)



XBTE013\*10

#### Terminals with 4 Lines of 40 Characters (Back-Lit LCD)

Downloadable Exchange Protocol	Number of Keys			Supply Voltage (VDC)	Language Version	Catalog Number	Weight lbs (kg)
	Function	Service	Alphanumeric				
<b>No Printer Port, No Log</b>							
See page 34	24	10	12	24	Multilingual	XBTE015010	2.2 (1.0)
<b>With Printer Port and Log</b>							
See page 34	24	10	12	24	Multilingual	XBTE015110	2.2 (1.0)



XBTE015\*10

### Separate Parts

Description	Use	Catalog Number	Weight lbs (kg)
Development Software	Under Windows 3.1 or 95, for downloading the application and protocols	See page 33	—
Connecting Cables	Connection to PLCs, configuration terminals, etc.	See page 34	—

### Documentation

Description	Format	Included in Product	Catalog Number ▲	Weight lbs (kg)
MAGELiS User's Manual	A5 Bound (148 x 210 mm, approx. 6 x 8.25 in)	XBTL1003* and XBTL1004*	XBTX000**	0.4 (0.2)

▲ Add the following suffixes **EN**: English, **FR**: French, **DE**: German, **ES**: Spanish, **IT**: Italian.



# MAGELiS® Operator Terminals

## XBTE Terminals with 2 or 4 Line Alphanumeric Screen

### Specifications

<b>Type of Terminal</b>		<b>XBTE014•10/XBTE016•10 (Fluorescent)</b>	<b>XBTE013•10/XBTE015•10 (Back-Lit LCD)</b>		
<b>Environment</b>					
<b>Conforming to Standards</b>		IEC 61131-2, IEC 60068-2-6, IEC 60068-2-27, EN 61131-2, UL 508, CSA C22-2 No. 142			
<b>Product Certifications</b>		CE, UL, CSA, UL E164866, CCN: NRAQ, CSA LR 44087, Class 2252 01			
<b>Temperature</b>	Operation	+32 to +122 °F (0 to +50 °C)			
	Storage	-40 to +158 °F (-40 to +70 °C)	-4 to +140 °F (-20 to +60 °C)		
<b>Degree of Protection</b>		IP 65, conforming to IEC 60529, NEMA Type 4, UL Type 4			
<b>Mechanical Characteristics</b>					
<b>Mounting and Fixing</b>		Flush-mounted, fixed with 4 or 6 screws (supplied), pressure-mounted on a panel of thickness 0.04–0.24 in. (1–6 mm)			
<b>Material</b>	Enclosure	Polyphenyl oxide, 10% glass fiber (PPO GFN1 SE1)			
	Keypad	Anti-UV treated toughened polyester (Autoflex EB AG)			
<b>Keys</b>	Function	24			
	Service	10			
	Alphanumeric	12			
<b>Electrical Characteristics</b>					
<b>Display Unit</b>	Fluorescent green matrix characters (5 x 7 pixels)		Back-lit LCD (5 x 7 pixels)		
		<b>XBTE014•10</b>	<b>XBTE016•10</b>	<b>XBTE013•10</b>	<b>XBTE015•10</b>
		2 lines of 40 characters, height 0.20 in. (5 mm)	4 lines of 40 characters, height 0.20 in. (5 mm)	2 lines of 40 characters, height 0.20 in. (5 mm)	4 lines of 40 characters, height 0.20 in. (5 mm)
<b>Power Supply</b>	Voltage	24 Vdc not isolated			
	Voltage Limits	18–30 V			
	Ripple	5% maximum			
<b>Consumption</b>		20 W	10 W		
<b>Operating Characteristics</b>					
<b>Signaling</b>		33 LEDs + 1 buzzer			
<b>Memory</b>		384 KB Flash EEPROM 800 application pages approximately (2 lines per page) 256 available alarm pages (2 lines per page) 400 application pages approximately (4 lines per page) 128 available alarm pages (4 lines per page)			
<b>Log Function</b>		Permits storage of alarm pages			
<b>Transmission (asynchronous serial link)</b>		RS 232 C / RS 485 / RS 422			
<b>Downloadable Protocol</b>		Multiple (see pages 8 and 34)			
<b>Real-Time Clock</b>		Access to the PLC real-time clock			
<b>Printer Port (asynchronous serial link)</b>		RS 232 C ( <b>XBTE014110</b> and <b>XBTE016110</b> )		RS 232 C ( <b>XBTE013110</b> and <b>XBTE015110</b> )	
<b>Alarm Relay</b>		1 N.O. contact min. 1 mA/5 Vdc max. 0.5 A/24 Vdc			
<b>Connection</b>	Power Supply and Alarm Relay	Plug-in terminal block 3 screw terminals, 13/64" (5.08 mm) pitch Maximum clamping capacity: #16 AWG (1.5 mm <sup>2</sup> ), 0.5–0.6 N•m			
	Serial Port	Female 25-pin SUB-D connector			
	Printer Port	Male 9-pin SUB-D connector			



# MAGELiS® Operator Terminals

## XBTHM/PM Display Units with 8 Line Matrix Screen

### Selection

#### Display Units with 8 Line Matrix Screen of 40 Characters (Back-Lit LCD)

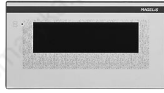

XBTHM007010

Downloadable Exchange Protocol See page 34	Number of Keys			Supply Voltage (VDC)	Language Version	Catalog Number	Weight lbs (kg)
	Function	Service	Alpha-numeric				
No Printer Port, No Log	—	—	—	24	Multilingual	XBTHM007010	1.3 (0.6)
	4	1	—	24	Multilingual	XBTHM027010	1.3 (0.6)
	—	5	—	24	Multilingual	XBTHM017010	1.3 (0.6)
PowerSuite▲	—	5	—	24	Multilingual	XBTHM017010A8	1.3 (0.6)
With Printer Port and Log	—	5	—	24	Multilingual	XBTHM017110	1.3 (0.6)

▲ Terminal specifically for controlling up to eight ATV28/ATV58 variable-speed drive controllers.

### Separate Parts



XBTHM027010

Description	Use	Catalog Number	Weight lbs (kg)
Development Software	Under Windows 95 or NT 4.0, for downloading the application and protocols	See page 33	—
Connecting Cables	Connection to PLCs, configuration terminals, etc.	See page 34	—

### Documentation

Description	Format	Included in Product	Catalog Number ▲	Weight lbs (kg)
MAGELiS User's Manual	A5 Bound (148 x 210 mm, approx. 6 x 8.25 in)	XBTL1003* and XBTL1004*	XBTX000**	0.4 (0.2)

▲ Add the following suffixes EN: English, FR: French, DE: German, ES: Spanish, IT: Italian.

### Specifications



XBTHM017\*10

Type of Display Unit	XBTHM0*7*10 (Back-Lit LCD)			
<b>Environment</b>				
<b>Conforming to Standards</b>	IEC 61131-2, IEC 60068-2-6, IEC 60068-2-27, EN 61131-2, UL 508, CSA C22-2 No. 142			
<b>Product Certifications</b>	CE, UL, CSA, UL E164866, CCN: NRAQ, CSA LR 44087, Class 2252 01			
<b>Temperature</b>	Operation	+32 to +122 °F (0 to +50 °C)		
	Storage	-4 to +140 °F (-20 to +60 °C)		
<b>Degree of Protection</b>	IP 65, conforming to IEC 60529, NEMA Type 4, UL Type 4			
<b>Mechanical Characteristics</b>				
<b>Mounting and Fixing</b>	Flush-mounted, fixed with spring clips (supplied), pressure-mounted on a panel of thickness 0.04–0.24 in. (1–6 mm)			
<b>Material</b>	Enclosure	Polyphenyl oxide, 10% glass fiber (PPO GFN1 SE1)		
	Keypad	Anti-UV treated toughened polyester (Autoflex EB AG)		
<b>Keys</b>		XBTHM007010	XBTHM027010	
		No keys	4 function keys + 1 service key	5 service keys
<b>Electrical Characteristics</b>				
<b>Display Unit</b>	Back-lit LCD (240 x 64 pixels) 8 lines of 40 character, height 0.21 in. (5.3 mm), single size 4 lines of 20 characters height 0.42 in. (10.6 mm), double height, double width			
<b>Power Supply</b>	Voltage	24 Vdc not isolated		
	Voltage Limits	18–30 V		
	Ripple	5% maximum		
<b>Consumption</b>	15 W			
<b>Operating Characteristics</b>				
<b>Signaling</b>		XBTHM007010	XBTHM027010	
		1 LED	6 LEDs	XBTHM017*10
<b>Memory</b>	384 KB Flash EEPROM 600 application pages approximately (8 lines per page), 256 available alarm pages (2 lines per page)			
<b>Transmission (asynchronous serial link)</b>	RS 232 C / RS 485 / RS 422			
<b>Downloadable Protocol</b>	Multiple (see pages 8 and 34)			
<b>Real-Time Clock</b>	Access to the PLC real-time clock			
<b>Printer Port (asynchronous serial link)</b>	RS 232 C (XBTHM017110)			
<b>Connection</b>	Power Supply	Plug-in terminal block 3 screw terminals, 13/64" (5.08 mm) pitch Maximum clamping capacity: #16 AWG (1.5 mm <sup>2</sup> ), 0.5–0.6 N•m		
	Serial Port	Female 25-pin SUB-D connector		
	Printer Port	Male 9-pin SUB-D connector		



# MAGELiS<sup>®</sup> Operator Terminals

## XBTHM/PM Display Units with 8 Line Matrix Screen

### Selection

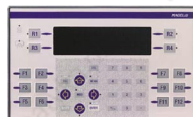

XBTPM

### Terminals with 8 Line Matrix Screen of 40 Characters (Back-Lit LCD)

Downloadable Exchange Protocol	Number of Keys				Supply Voltage (VDC)	Language Version	Catalog Number	Weight lbs (kg)
	Function	Dynamic Function	Service	Alpha-numeric				
No Printer Port See page 34	12	4	10	12	24	Multilingual	<b>XBTPM027010</b>	1.32 (0.6)
With Printer Port See page 34	12	4	10	12	24	Multilingual	<b>XBTPM027110</b>	1.32 (0.6)

### Separate Parts

Description	Use	Catalog Number	Weight lbs (kg)
Development Software	Under Windows 95 or NT 4.0, for downloading the application and protocols	See page 33	—
Connecting Cables	Connection to PLCs, configuration terminals, etc.	See page 34	—

### Documentation

Description	Format	Included in the Product	Catalog Number ▲	Weight lbs (kg)
MAGELiS © User's Manual	A5 Bound (148 x 210 mm, approx. 6 x 8.25 in)	XBTL1003* and XBTL1004*	<b>XBTX000**</b>	0.4 (0.2)

▲ Add the following suffixes **EN**: English, **FR**: French, **DE**: German, **ES**: Spanish, **IT**: Italian.



### Specifications

<b>Type of Display Unit</b>	<b>XBTPM027*10 (Back-Lit Matrix LCD)</b>		
<b>Environment</b>			
<b>Conforming to Standards</b>	IEC 61131-2, IEC 60068-2-6, IEC 60068-2-27, EN 61131-2, UL 508, CSA C22-2 No. 142		
<b>Product Certifications</b>	CE, UL, CSA, UL E164866, CCN: NRAQ, CSA LR 44087, Class 2252 01, UL Class 1, Division 2, groups ABCD T5		
<b>Temperature</b>	Operation	+32 to +122 °F (0 to +50 °C)	
	Storage	-4 to +140 °F (-20 to +60 °C)	
<b>Degree of Protection</b>	IP 65, conforming to IEC 60529, NEMA Type 4, UL Type 4		
<b>Mechanical Characteristics</b>			
<b>Mounting and Fixing</b>	Flush-mounted, fixed with spring clips (supplied), pressure-mounted on a panel of thickness 0.06–0.24 in. (1.6–6 mm)		
<b>Material</b>	Enclosure	Polyphenyl oxide, 10% glass fiber (PPO GFN1 SE1)	
	Keypad	Anti-UV treated toughened polyester (Autoflex EB AG)	
<b>Keys</b>	Function	12 static, 4 dynamic	
	Service	12	
	Numeric	12	
<b>Electrical Characteristics</b>			
<b>Display Unit</b>	Back-lit LCD (240 x 64 pixels) 8 lines of 40 characters, height 0.21 in. (5.3 mm), single size 4 lines of 20 characters, height 0.42 in. (10.6 mm), double height, double width		
<b>Power Supply</b>	Voltage	24 Vdc, not isolated	
	Voltage Limits	18–30 V	
	Ripple	5% maximum	
<b>Consumption</b>	15 W		
<b>Operating Characteristics</b>			
<b>Signaling</b>	25 LEDs		
<b>Memory</b>	256 KB Flash EEPROM 400 application pages approximately 256 available alarm pages depending on distribution		
<b>Transmission (asynchronous serial link)</b>	RS 232 C / RS 485 / RS 422		
<b>Downloadable Protocol</b>	Multiple (see pages 8 and 34)		
<b>Real-Time Clock</b>	Access to the PLC real-time clock		
<b>Printer Port (asynchronous serial link)</b>	RS 232 C ( <b>XBTPM027110</b> )		
<b>Connection</b>	Power Supply	Plug-in terminal block 3 screw terminals 13/64" (5.08 mm) pitch Maximum clamping capacity: #16 AWG (1.5 mm <sup>2</sup> ), 0.5–0.6 N•m	
	Serial Port	25-pin SUB-D connector	
	Printer Port	9-pin SUB-D connector	

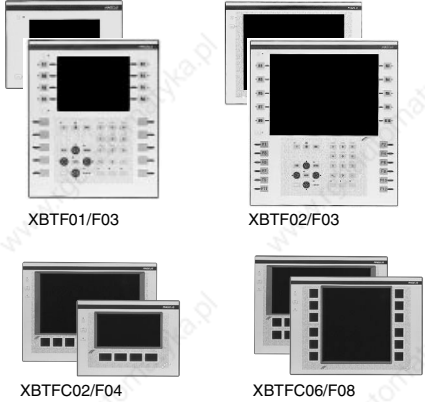

# MAGELiS® Operator Terminals XBTF Terminals with Graphic Screen

## General

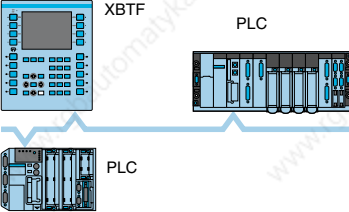
<b>Presentation</b>	 <p>XBTF01/F03      XBTF02/F03</p> <p>XBTF02/F04      XBTF06/F08</p>	<p>Graphic screen operator dialogue terminals are available with 5 or 10 in. (127 or 254 mm) screens, in monochrome or color, with a keypad or a touch-sensitive screen.</p> <p>XBTF graphic screen terminals are specially designed for operator dialogue graphic functions.</p>
<b>Operation</b>		<p>All MAGELiS graphic screen terminals have the same user interface: static and dynamic function keys, service keys, alphanumeric keys.</p>
<b>Configuration</b>		<p>MAGELiS graphic screen terminals can be configured using the same XBTL100• software in a Windows environment.</p> <p>XBTL100• software provides graphic screen terminals with a library of animated graphic objects such as bargraphs, volume indicator meters, selectors, potentiometers, and trending curves.</p> <p>The variable for animating an object can be selected directly from a list of symbols given by the PL7 or CONCEPT™ software.</p> <p>The application program for the graphic terminals is stored on a PCMCIA memory card.</p>
<b>Communication</b>		<p>XBTF graphic screen terminals communicate with PLCs via an integrated point-to-point or multidrop serial link, or via a field bus with a PCMCIA Type III card.</p> <p>The communication protocols are those used by Schneider Electric PLCs as well as those of the other main market suppliers.</p>



### Functions

XBTf graphic screen operator dialogue terminals have the following functions:

- Displaying animated synoptic screens, control, modification of numeric and alphanumeric variables
- Displaying a service line (status and alarm bar) with the current time
- Dynamic visualization of operating data (setpoints, measurements, recipes, maintenance messages) and process errors
- Control via dynamic or static function keys
- Scaling analog variables
- Real-time and trending curves
- Alarm log and managing alarm groups
- Managing help pages, form pages, recipe pages
- Pages called by the user or by the PLC
- Three levels of passwords
- Printing form pages, date-stamped log and alarms
- Communication protocol application support in the PCMCIA Type II application memory card

The role of the function keys is defined using the XBTL100• software. Modifications cannot be made during operation. Each function key can be associated with an internal bit of the PLC application.

### Static Function Keys (F•)

Static function keys are defined for the whole application.

They perform the following actions:

- Accessing a page
- Pulse control
- Toggle set/reset control

Static keys can be marked with reusable labels.

### Dynamic function keys and touch-sensitive keys

Dynamic function keys and touch-sensitive keys are associated with a page. Their role can therefore differ from one page to another.

They perform the following actions:

- Accessing a page
- Latching memory bits
- Toggling memory bits (on/off)
- Accessing the modification of a value
- Direct writing

Each dynamic key and touch-sensitive key can be assigned a label or icon illustrating its function.

On touch-sensitive terminals, the touch-sensitive zones function in a similar way to the dynamic keys on keypad terminals.



# MAGELiS® Operator Terminals

## XBTF Terminals with Graphic Screen

### Service Keys

Service keys are the arrow keys and the control keys combined. Service keys are used to modify the parameters of the control system.

The control keys perform the following actions:

<b>ENTER</b>	Confirm a selection or entry, acknowledge an alarm
<b>MOD</b>	Change to the mode for entering pages, passwords, fields, or graphic objects
<b>ESC</b>	Cancel an entry, suspend or stop a current action; display previous pages in succession; quit the alarm display
<b>SHIFT</b>	Access the second of the dual key functions
<b>MENU</b>	Access a menu containing the operating functions that do not have direct access keys
<b>HOME</b>	Return to the entry point of the current menu Example: return to the first page of the application
<b>SYST</b>	Access the confidential mode that contains the password-protected implementation functions
<b>ALARM</b>	View the alarms
<b>PRINT</b>	Print

The arrow keys perform the following actions:

- Change the page within a menu
- Change fields on a page
- Select an object on a page
- Move within a page
- Select the value of a digit
- Select a value from a list of choices
- When used with the **SHIFT** key, increment or decrement the value of a variable field

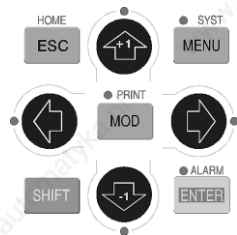

# MAGELiS® Operator Terminals

## XBTF Terminals with Graphic Screen

### XBTF01/F02 Description

The front panel of XBTF01/F02 keypad terminals includes:

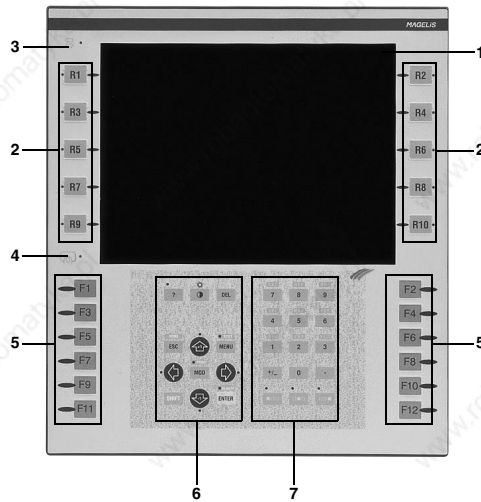

1. A monochrome or color screen 5.7, 9.5, or 10.4 in. (145, 241, or 264 mm) depending on the model
2. 2 x 4 or 2 x 5 dynamic function keys (depending on the model) with indicator lights
3. A communication monitoring indicator light
4. A keypad activity indicator light
5. 2 x 5 or 2 x 6 static function keys (depending on the model) with indicator lights and re-usable labels
6. Twelve service keys with indicator lights
7. Twelve alphanumeric keys [0 to 9, (+/-), (.)] associated with three alphabetical access keys (A to Z)

The front panel of XBTF03 touch-sensitive screen terminals includes:

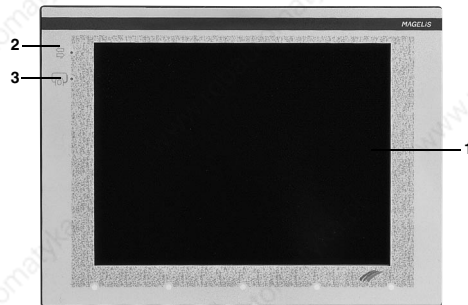

1. A touch-sensitive color screen 5.7 or 10.4 in. (145 or 264 mm) depending on the model
2. A communication monitoring indicator light
3. A tactile feedback activity indicator light

The front panel of XBTF04 touch-sensitive screen terminals includes:

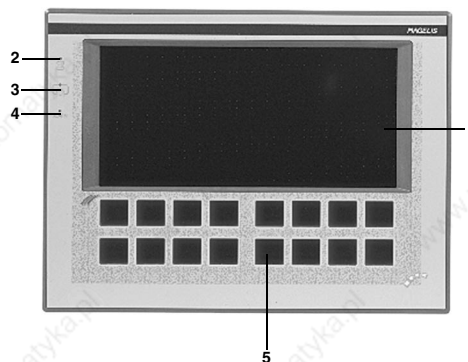

1. A touch-sensitive color screen 5.7 or 10.4 in. (145 or 264 mm) depending on the model
2. A communication monitoring indicator light
3. A tactile feedback activity indicator light
4. An alarm indicator light
5. 4, 8, 12, or 16 touch-sensitive keys (depending on the Touch 'n Click model)



# MAGELiS® Operator Terminals

## XBTF Terminals with Graphic Screen

### Selection

#### Terminals with Keypads

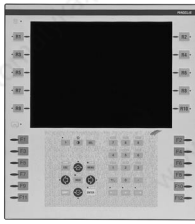

XBTF024\*10

Downloadable Exchange Protocol	Type and Size of Screen	Supply Voltage (VDC)	Type III Slot for PCMCIA Communication Card	Catalog Number	Weight lbs (kg)
See page 34	Monochrome 5.7 in. (145 mm)	24	No	XBTF011110	4.0 (1.8)
			Yes	XBTF011310	4.0 (1.8)
	Monochrome 9.5 in. (241 mm)	24	No	XBTF023110	6.0 (2.7)
			Yes	XBTF023310	6.0 (2.7)
	Color 10.4 in. (264 mm)	24	No	XBTF024110	6.0 (2.7)
			Yes	XBTF024310	6.0 (2.7)

#### Terminals with Touch-Sensitive Screens



XBTF034\*10

Downloadable Exchange Protocol	Type and Size of Screen	Supply Voltage (VDC)	Type III Slot for PCMCIA Communication Card	Catalog Number	Weight lbs (kg)
See page 34	Color 5.7 in. (145 mm)	24	No	XBTF032110	3.5 (1.6)
			Yes	XBTF032310	3.5 (1.6)
	Color 10.4 in. (264 mm)	24	No	XBTF034110	5.3 (2.4)
			Yes	XBTF034310	5.3 (2.4)

#### Separate Parts

Description	Use	Catalog Number	Weight lbs (kg)
Development Software	Under Windows 95 or NT 4.0, for downloading the application and protocols	See page 33	—
PCMCIA Type II Memory Cards	Application memory	See page 34	—
PCMCIA Type III Memory Cards	Bus and industrial networks connection	See page 34	—
Connecting Cables	Connection to PLCs, configuration terminals, etc.	See page 34	—
Sheet of Labels	Labels for function keys	See page 34	—

#### Replacement Parts



XBTFMEM08

Description	Use	Memory	Catalog Number	Weight lbs (kg)
PCMCIA Type II Memory Card	XBTF terminals	8 MB	XBTFMEM08	0.2 (0.1)
PCMCIA Type II Memory Card	XBTF terminals	16 MB	XBTFMEM16	0.2 (0.1)



# MAGELIS® Operator Terminals XBTF Terminals with Graphic Screen

## Specifications

Type of Terminal	XBTF011	XBTF032	XBTF023/F024	XBTF034	
<b>Environment</b>					
<b>Conforming to Standards</b>	IEC 61131-2, IEC 60801-2 level 3, IEC 60801-3 and IEC 60801-4 level 3, IEC 60068-2-6, IEC 60068-2-27, UL 508, CSA C22.2 No. 142				
<b>Product Certifications</b>	CE, UL Class 1, Div 2. Group A, B, C, D-T4A, CSA Class 1, Div 2. Group A, B, C, D-T4A				
<b>Temperature</b>	Operation	+32 to +113 °F (0 to +45 °C)			
	Storage	−4 to +140 °F (−20 to +60 °C)			
<b>Degree of Protection</b>	Front Panel	IP 65, conforming to IEC 60529, NEMA Type 4, UL Type 4			
	Rear Panel	IP 20, conforming to IEC 60529			
<b>Mechanical Characteristics</b>					
<b>Mounting and Fixing</b>	Flush-mounted, fixed with spring clips (supplied), pressure-mounted on a panel of thickness 0.06–0.24 in. (1.6–6 mm)				
	10 spring clips	8 spring clips	12 spring clips	10 spring clips	
<b>Material</b>	Front Section	Polyphenyl oxide, 10% glass fiber (PPO GFN1 SE1)			
	Keypad	Anti-UV treated toughened polyester (Autoflex EB AG)			
	Enclosure	Polyphenyl oxide, 10% glass fiber (PPO GFN1 SE1)			
<b>Keys</b>	Dynamic Keys	8 (with LED)	—	10 (with LED)	—
	Static Keys	10 (with LED and re-usable labels)	—	12 (with LED and re-usable labels)	—
	Service Keys	12	—	12	—
	Alphanumeric Keys	12, plus 3 for alphabetical access	—	12, plus 3 for alphabetical access	—
<b>Electrical Characteristics</b>					
<b>LED Screen</b>	Type	5.7 in. (145 mm) monochrome, back-lit with 16 levels of grey	5.7 in. (145 mm) STN 256 colors, back-lit with resistive matrix tactile feedback	XBTF023: 9.5 in. (241 mm) monochrome, back-lit with 16 levels of grey XBTF024: 10.4 in. (264 mm) TFT 256 colors	10.4 in. (264 mm) TFT 256 colors with resistive matrix tactile feedback
	Resolution	320 x 240 pixels		640 x 480 pixels	
<b>Power Supply</b>	Voltage	24 Vdc not isolated			
	Voltage Limits	18–30 V, maximum ripple 5%, maximum microbreaks 1 ms			
	Protection	Against polarity inversion and overloads			
<b>Consumption</b>	35 W				
<b>Operating Characteristics</b>					
<b>Signaling</b>	1 LED for communication monitoring, 1 LED for keypad activity (or tactile feedback activity), and 11 LEDs associated with service and alphanumeric keys				
<b>Operating System</b>	MAGELIS				
<b>Dynamic RAM Memory</b>	2.5 MB				
<b>Application Memory</b>	On 8 MB PCMCIA Type II card (supplied), 8, 16 MB				
<b>Dialogue Application</b>	Max. number of pages	50–450 application, alarm, help, form, and recipe pages depending on the memory card used		30–300 application, alarm, help, form, and recipe pages depending on the memory card used	
	Curves	16 real-time curves		16 real-time curves	
<b>Real-Time Clock</b>	Access to the PLC real-time clock				
<b>Alarm Relay</b>	One volt-free N.O. contact, max. 0.5 A, 24 Vdc/Vac				
<b>Connection</b>	Power Supply and Alarm Relay	Plug-in terminal, 5 screw terminals, 13/64" (5.08 mm) pitch Maximum clamping capacity: #16 AWG (1.5 mm <sup>2</sup> ), 0.5–0.6 N•m			
	PLC	Female 25-pin SUB-D connector			
	Printer/Configuration PC	Male 9-pin SUB-D connector			



# MAGELiS® Operator Terminals

## Pentium Processor Terminal with Graphic Screen

### Selection

#### Terminals with Keypads and pentium processor

Downloadable Exchange Protocol	Type and Size of Screen	Supply Voltage (VDC)	RJ 45 Ethernet 10/100 TCP/IP Connector	Catalog Number	Weight lbs (kg)
See page 34	Color 10.4 in. (264 mm)	24	No	<b>XBTF024510</b>	6.0 (2.7)
			Yes	<b>XBTF024610</b>	6.0 (2.7)

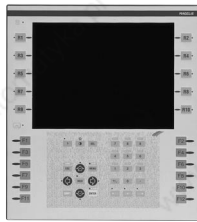

XBTF024\*10

#### Terminals with Touch-Sensitive Screens and pentium processor

Downloadable Exchange Protocol	Type and Size of Screen	Supply Voltage (VDC)	RJ 45 Ethernet 10/100 TCP/IP Connector	Catalog Number	Weight lbs (kg)
See page 34	Color 10.4 in. (264 mm)	24	No	<b>XBTF034510</b>	5.3 (2.4)
			Yes	<b>XBTF034610</b>	5.3 (2.4)



XBTF034\*10

### Specifications

Type of Terminal	<b>XBTF024</b>		<b>XBTF034</b>
<b>Environment</b>			
<b>Conforming to Standards</b>	IEC 61131-2, IEC 61000-4-2 level 3, IEC 61000-4-3 and IEC 61000-4-4 level 3, IEC 60068-2-6, IEC 60068-2-27, UL 508, CSA		
<b>Product Certifications</b>	CE, UL Class 1, Div 2. Group A, B, C, D-T4A, CSA Class 1, Div 2. Group A, B, C, D-T4A		
<b>Temperature</b>	Operation	+32 to +113 °F (0 to +45 °C)	
	Storage	-4 to +140 °F (-20 to +60 °C)	
<b>Relative Humidity</b>	0 to 85 % (without condensation)		
<b>Degree of Protection</b>	Front Panel	IP 65, conforming to IEC 60529, NEMA Type 4	
	Rear Panel	IP 20, conforming to IEC 60529	
<b>Shock Resistance</b>	Conforming to IEC 60068-2-27; semi-sinusoidal pulse 11 ms, 15 gn in the 3 axes		
<b>Vibrations</b>	Conforming to IEC 60068-2-6; 10 to 57 Hz at 0.075 mm; 57 to 150 Hz 1 g for 3 hours per axis		
<b>Electrostatic discharge</b>	Conforming to IEC 61000-4-2, level 3		
<b>Electromagnetic interference</b>	Conforming to IEC 61000-4-3, 10 V/m		
<b>Electrical interference</b>	Conforming to IEC 61000-4-4, level 3		
<b>Mechanical Characteristics</b>			
<b>Mounting and Fixing</b>	Flush-mounted, fixed with spring clips (supplied), pressure-mounted on a panel of thickness 0.06–0.24 in. (1.6–6 mm)		
		12 spring clips	10 spring clips
<b>Material</b>	Screen Protection	0.12 in. (3 mm) thick glass	0.07 in. (1.8 mm) thick glass + 0.008 in. (0.2 mm) thick polyester
	Front Section	Polyphenyl oxide, 10% glass fiber (PPO GFN1 SE1)	
	Keypad	Anti-UV treated toughened polyester (Autoflex EB AG)	
	Enclosure	Polyphenyl oxide, 10% glass fiber (PPO GFN1 SE1)	
<b>Keys</b>	Dynamic Keys	10 (with LED)	—
	Static Keys	12 (with LED and re-usable labels)	—
	Service Keys	12	—
	Alphanumeric Keys	12, plus 3 for alphabetical access	—
<b>Electrical Characteristics</b>			
<b>LED Screen</b>	Type	10.4 in. (264 mm) TFT 256 colors	10.4 in. (264 mm) TFT, 256 colors with resistive matrix tactile feedback (13 x 10 cells)
	Resolution	640 x 480 pixels	
	Luminescence	250 cd/m <sup>2</sup>	
<b>Optimum View Angle (degrees)</b>	Vertical top	80	80
	Vertical bottom	80	80
	Vertical right	80	80
	Vertical left	80	80



## MAGELiS® Operator Terminals

### Pentium Processor Terminal with Graphic Screen

<b>Type of Terminal</b>		<b>XBTF024</b>	<b>XBTF034</b>
<b>Power Supply</b>	Voltage	24 Vdc not isolated	
	Voltage Limits	18–30 V, maximum ripple 5%, maximum microbreaks 1 ms	
	Protection	Against polarity inversion and overloads	
<b>Consumption</b>		35 W	
<b>Operating Characteristics</b>			
<b>Signaling</b>		1 LED for communication monitoring, 1 LED for keypad activity (or tactile feedback activity), and 11 LEDs associated with service and alphanumeric keys	
<b>Operating System</b>		MAGELiS / Pentium	
<b>Dynamic RAM Memory</b>		32 MB	
<b>Application Memory</b>		On 8 MB PCMCIA Type II card (supplied), 8, 16 MB	
<b>Dialogue Application</b>	Max. number of pages	30–300 application, alarm, help, form, and recipe pages depending on the memory card used (max 512 alarms, max 256 form)	
	Curves	16 real-time curves	
	Recipes	Maximum 5000 parameter values in a maximum of 125 recipe records	
<b>Communication</b>	PLC / Configuration PC	115200 baud RS 232 C/RS 422/485 isolated serial link, downloadable communication protocols (see page 34)	
	Printer	RS 232 C serial link	
	Bus or Network	Slot for type III PCMCIA communication card, communication protocols (see page 34). RJ 45 Ethernet 10/100 TCP/IP connector, depending on model	
<b>Real-Time Clock</b>		Built-in and backed-up	
<b>Alarm Relay</b>		One volt-free N.O. contact, max. 0.5 A, 24 Vdc/Vac	
<b>Connection</b>	Power Supply and Alarm Relay	Plug-in terminal, 5 screw terminals, 13/64 in. (5.08 mm) pitch Maximum clamping capacity: #16 AWG (1.5 mm <sup>2</sup> ), 0.5–0.6 N•m	
	PLC	Female 25-pin SUB-D connector	
	Printer/Configuration PC	Male 9-pin SUB-D connector	



# MAGELiS® Operator Terminals

## XBTFC Touch 'n Click terminals

### MAGELiS Touch 'n Click terminals

#### Selection



XBTFC022310

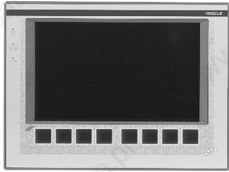

XBTFC044310

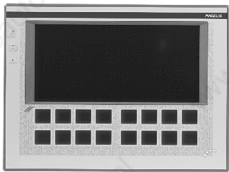

XBTFC084310

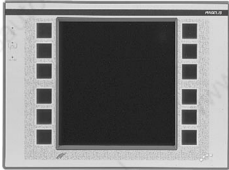

XBTFC064310



XBTMEM08

#### Terminals with touch-sensitive screens

Downloadable Exchange Protocol	Type and Size of Screen	Supply voltage (VDC)	Number of touch-sensitive keys	Catalog Number	Weight lb (kg)
See page 34	Color 5.7 in. (145 mm)	24	4	XBTFC022310	3.5 (1.6)
	Color 10.4 in. (264 mm)	24	8	XBTFC044310	5.3 (2.4)
			16	XBTFC084310	5.3 (2.4)
			12	XBTFC064310	5.3 (2.4)

#### Separate parts

Description	Use	Catalog Number	Weight lb (kg)
Development Software	Under Windows 95 or NT 4.x, for downloading the application and protocols	See page 33	—
Type II PCMCIA Memory Cards	Application memory	See page 34	—
Type III PCMCIA Communication Cards	Connection to buses and industrial networks	See page 34	—
Connecting Cables	Serial link, UNI-TELWAY bus, configuration terminal, printer connection	See page 34	—

#### Replacement part

Description	Use	Memory size	Catalog Number	Weight lb (kg)
Type II PCMCIA Memory Card	XBTFC terminals	8 MB	XBTMEM08	0.22 (0.1)
Type II PCMCIA Memory Card	XBTFC terminals	16 MB	XBTMEM16	0.22 (0.1)



# MAGELiS® Operator Terminals

## XBTFC Touch 'n Click terminals

### MAGELiS Touch 'n Click terminals

#### Specifications

Type of terminal	XBTFC022310	XBTFC044310	XBTFC084310	XBTFC064310		
<b>Environment</b>						
<b>Conforming to Standards</b>	IEC 61131-2, IEC 61000-4-2 level 3, IEC 61000-4-3 and IEC 61000-4-4 level 3, IEC 60068-2-6, IEC 60068-2-27, UL 508, CSA C22.2 No. 142					
<b>Approvals</b>	CE, UL, CSA					
<b>Temperature</b>	Operation	+32 to +113 °F (0 to +45 °C)				
	Storage	-4 to +140 °F (-20 to +60 °C)				
<b>Relative humidity</b>	0-85% (without condensation)					
<b>Degree of Protection</b>	Front panel	IP 65, conforming to IEC 60529, NEMA Type 4, UL Type 4				
	Back panel	IP 20, conforming to IEC 60529				
<b>Shock Resistance</b>	Conforming to IEC 60068-2-27; semi-sinusoidal pulse 11 ms, 15 g in the 3 axes					
<b>Vibrations</b>	Conforming to IEC 60068-2-6; 10-57 Hz at 0.075 mm (0.003 in.); 57-150 Hz 1 g for 3 hours per axis					
<b>Electrostatic Discharge</b>	Conforming to IEC 61000-4-2, level 3					
<b>Electromagnetic Interference</b>	Conforming to IEC 61000-4-3, 10 V/m					
<b>Electrical Interference</b>	Conforming to IEC 61000-4-4, level 3					
<b>Mechanical Characteristics</b>						
<b>Mounting and Fixing</b>	Flush-mounted, fixed with spring clips (supplied), pressure-mounted on a panel of thickness 0.06-0.24 in. (1.6-6 mm)					
		8 spring clips	10 spring clips			
<b>Material</b>	Screen protection	1.6 mm (0.06 in.) polyester	2 mm (0.08 in.) polyester			
	Front frame	Polyphenyl oxide, 10% glass fibre (PPO GFN1 SE 1)				
	Keypad	Anti-UV treated toughened polyester (Autoflex EB AG)				
	Enclosure	Polyphenyl oxide, 10% glass fibre (PPO GFN1 SE 1)				
<b>Touch-Sensitive Keys</b>	4 in one row	8 in one row	16 in two rows	12 in two columns		
<b>Electrical Characteristics</b>						
<b>LCD Screen</b>	Type	5.7 in. (145 mm) STN 256 colors back-lit with resistive matrix tactile feedback (8 x 4 cells)	10.4 in. (264 mm) TFT 256 colors with resistive matrix tactile feedback	13 x 8 cells	13 x 6 cells	9 x 10 cells
	Definition	320 x 240 pixels	640 x 480 pixels			
<b>Power Supply</b>	Voltage	24 Vdc not isolated				
	Limits	18-30 V, including 5% maximum ripple, microbreaks 1 ms maximum				
	Protection	Against polarity inversion and overloads				
<b>Consumption</b>	35 W					
<b>Operating characteristics</b>						
<b>Signaling</b>	1 communication monitoring LED, 1 keypad activity LED and 11 alarm LEDs					
<b>Operating System</b>	MAGELiS					
<b>Dynamic RAM Memory</b>	2.5 MB					
<b>Application Memory</b>	On Type II PCMCIA card: 8 MB (supplied) or 16 MB					
<b>Dialogue Application</b>	Maximum no. of pages	50-450 application, alarm, help, form, and recipe pages depending on the memory card used (512 alarm and 256 form max.)	30-300 application, alarm, help, form, and recipe pages depending on the memory card used (512 alarm and 256 form max.)			
	Curves	16 real-time curves				
	Recipes	Maximum 5000 parameter values in a maximum of 125 recipe records				
<b>Communication</b>	PLC/ Configuration PC	RS 232 C / RS 422 / RS 485 isolated serial link, downloadable communication protocols (see pages 6 and 7)				
	Printer	RS 232 C serial link				
	Bus or network	Slot for Type III PCMCIA communication card, communication protocols (see page 7)				
<b>Real-Time Clock</b>	Access to the PLC real-time clock					
<b>Alarm Relay</b>	1 volt-free N.O. contact, max 0.5 A, 24 Vdc/Vac					
<b>Connection</b>	Power supply and alarm relay	Plug-in terminal block, 5 screw terminals at intervals of 13/64 in. (5.08 mm) Max clamping capacity: #16 AWG (1.5 mm <sup>2</sup> )				
	PLC	25-pin female SUB-D connector				
	Printer/ Configuration PC	9-pin male SUB-D connector				



# MAGELiS® Operator Terminals

## XBTFC Pentium Processor-Based Touch 'n Click terminals

### MAGELiS Touch 'n Click terminals with a pentium processor

#### Selection

#### Terminals with touch-sensitive screens and pentium processor

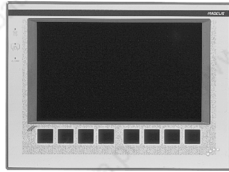

XBTFC044\*10

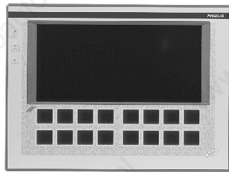

XBTFC084\*10

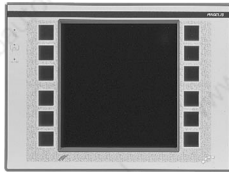

XBTFC064\*10

Downloadable Exchange Protocol	Type and Size of Screen	Supply voltage (VDC)	Number of touch-sensitive keys	RJ 45 Ethernet 10/100 TCP/IP Connector	Catalog Number	Weight lb (kg)
See page 34	Color 10.4 in. (264 mm)	24	8	No	XBTFC044510	5.3 (2.4)
				Yes	XBTFC044610	5.3 (2.4)
			16	No	XBTFC084510	5.3 (2.4)
				Yes	XBTFC084610	5.3 (2.4)
			12	No	XBTFC064510	5.3 (2.4)
				Yes	XBTFC064610	5.3 (2.4)

#### Specifications

Type of terminal	XBTFC044	XBTFC084	XBTFC064	
<b>Environment</b>				
<b>Conforming to Standards</b>	IEC 61131-2, IEC 61000-4-2 level 3, IEC 61000-4-3 and IEC 61000-4-4 level 3, IEC 68-2-6, IEC 68-2-27, UL 508, CSA			
<b>Approvals</b>	CE, UL Class 1, Div 2. Group A, B, C, D-T4A, CSA Class 1, Div 2. Group A, B, C, D-T4A			
<b>Temperature</b>	Operation	+32 to +113 °F (0 to +45 °C)		
	Storage	-4 to +140 °F (-20 to +60 °C)		
<b>Relative humidity</b>	0-85% (without condensation)			
<b>Degree of Protection</b>	Front panel	IP 65, conforming to IEC 60529, NEMA Type 4		
	Back panel	IP 20, conforming to IEC 60529		
<b>Shock Resistance</b>	Conforming to IEC 68-2-27; semi-sinusoidal pulse 11 ms, 15 g in the 3 axes			
<b>Vibrations</b>	Conforming to IEC 68-2-6; 10-57 Hz at 0.075 mm (0.003 in.); 57-150 Hz 1 g for 3 hours per axis			
<b>Electrostatic Discharge</b>	Conforming to IEC 61000-4-2, level 3			
<b>Electromagnetic Interference</b>	Conforming to IEC 61000-4-3, 10 V/m			
<b>Electrical Interference</b>	Conforming to IEC 61000-4-4, level 3			
<b>Mechanical Characteristics</b>				
<b>Mounting and Fixing</b>	Flush-mounted, fixed with spring clips (supplied), pressure-mounted on a panel of thickness 0.06-0.24 in. (1.6-6 mm)			
	10 spring clips			
<b>Material</b>	Screen protection	1.8 mm (0.07 in.) thick glass + 0.2 mm (0.008 in.) thick polyester		
	Front frame	Polyphenyl oxide, 10% glass fibre (PPO GFN1 SE 1)		
	Keypad	Anti-UV treated toughened polyester (Autoflex EB AG)		
	Enclosure	Polyphenyl oxide, 10% glass fibre (PPO GFN1 SE 1)		
<b>Touch-Sensitive Keys</b>	8 in one row	16 in two rows	12 in two columns	
<b>Electrical Characteristics</b>				
<b>LCD Screen</b>	Type	10.4 in. (264 mm) TFT 256 colors with resistive matrix tactile feedback XBTFC044 has 13 x 8 cells, XBTFC 084 has 13 x 6 cells, XBTFC064 has 9 x 10 cells,		
	Definition	640 x 480 pixels		
	Luminescence	250 cd/m <sup>2</sup>	250 cd/m <sup>2</sup>	250 cd/m <sup>2</sup>
<b>Optimum View Angle (degrees)</b>	Vertical top	80	80	80
	Vertical bottom	80	80	80
	Vertical right	80	80	80
	Vertical left	80	80	80
	Voltage	24 Vdc not isolated		
<b>Power Supply</b>	Limits	18-30 V, including 5% maximum ripple, microbreaks 1 ms maximum		
	Protection	Against polarity inversion and overloads		



## MAGELiS® Operator Terminals

### XBTFC Pentium Processor-Based Touch 'n Click terminals

#### Specifications

Type of terminal	XBTFC044	XBTFC084	XBTFC064
<b>Consumption</b>	35 W		
<b>Operating characteristics</b>			
<b>Signaling</b>	1 communication monitoring LED, 1 tactile feedback keypad activity LED and 1 alarm LED		
<b>Operating System</b>	MAGELiS / Pentium		
<b>Dynamic RAM Memory</b>	32 MB		
<b>Application Memory</b>	On 8 MB PCMCIA Type II card (supplied), 8, 16 MB		
<b>Dialogue Application</b>	Maximum no. of pages	30–300 application, alarm, help, form, and recipe pages depending on the memory card used (512 alarm and 256 form max.)	
	Curves	16 real-time curves	
	Recipes	Maximum 5000 parameter values in a maximum of 125 recipe records	
<b>Communication</b>	PLC/ Configuration PC	115200 baud RS 232 C / RS 422 / RS 485 isolated serial link, downloadable communication protocols (see pages 6 and 7)	
	Printer	RS 232 C serial link	
	Bus or network	Slot for Type III PCMCIA communication card, communication protocols (see page 7) RJ 45 Ethernet 10/100 TCP/IP connector, depending on model	
<b>Real-Time Clock</b>	Built-in and backed-up		
<b>Alarm Relay</b>	1 volt-free N.O. contact, max 0.5 A, 24 Vdc/Vac		
<b>Connection</b>	Power supply and alarm relay	Plug-in terminal block, 5 screw terminals at intervals of 13/64 in. (5.08 mm) Max clamping capacity: #16 AWG (1.5 mm <sup>2</sup> )	
	PLC	25-pin female SUB-D connector	
	Printer/ Configuration PC	9-pin male SUB-D connector	



# MAGELiS® Operator Terminals Development Software

## XBTL1003/L1004 Software Functions

### Simulation on PC compatible

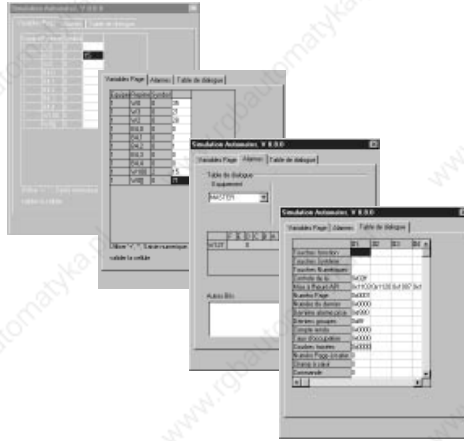

XBTL1003/L1004 software offers the option of simulating all the operator dialogue applications from the design office without the use of graphic terminals and PLCs.

The following can be tested using the simulation program and the keyboard on a PC compatible:

- Navigating between pages
- Entering variables
- Displaying variables
- Simulating an alarm

### Using the function keys

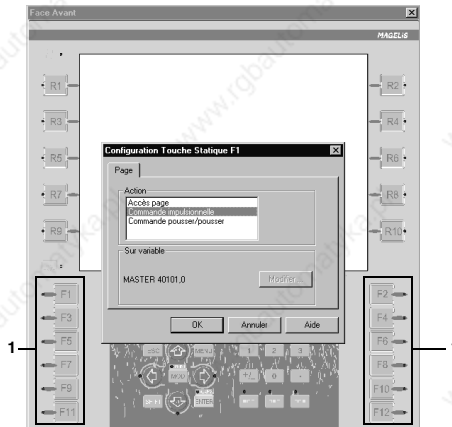

The operator terminals and graphic stations have two types of function keys: static and dynamic.

#### 1. Static keys

These are defined for the whole application.

They may have the following functions:

- Access a page
- Pulse a PLC memory bit
- Latch a PLC memory bit

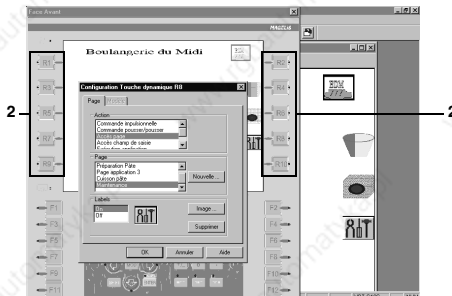

#### 2. Dynamic keys

These are associated with one page. Their role can be reassigned or changed from one page to another.

They may have the following functions:

- Access a page
- Pulse a PLC memory bit
- Latch a PLC memory bit
- Position on a data entry field

A label (bitmap image) is assigned to each key, which may vary from page to page.



## XBTL1003/1004 Software

XBTL1003/L1004 development software is used with the whole range of MAGELiS terminals to create operator dialogue applications designed for controlling automated systems.

XBTL1003/L1004▲ software runs on PC compatibles equipped with Windows 95 or NT 4.0 operating software. Applications created using XBTL1003/L1004 software are independent of the protocol used; it is possible to use the same operator dialogue application with all the different PLCs offered by the main market suppliers.

## Configuration

XBTL1003/L1004 software is the only configuration software package for the MAGELiS range. It runs under Windows 95 or NT 4.0.

It is used to create various types of pages easily:

- Application pages (can be interlinked)
- Alarm pages
- Help pages
- Recipe pages
- Form pages

The pages can contain all sorts of variables and graphic objects, which are either predefined in the XBTL1003/L1004 software or created using other applications and then imported (bitmap format, etc.). Various properties can be assigned to them: min-max limits, color, movement, weighting, etc.

XBTL1003/L1004 software can be used to configure the function keys to activate commands on the machine or call application pages. It can also be used on the graphic terminals to import the PL7 or CONCEPT PLC symbols database.

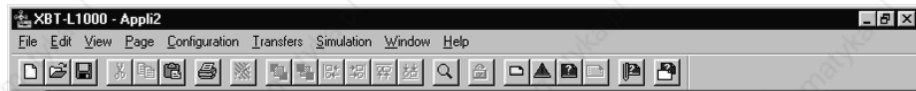

Main toolbar



Graphic toolbar

Page Tree Structure window

▲ The XBTL1000 software package is designed for DOS 5.0 (minimum) with the Windows 3.1 operating system. Hardware requirements are a minimum of a 386 processor operating at 25 MHz, with 8 MB RAM and 20 MB free hard disk space.

# MAGELiS® Operator Terminals Development Software

## Screen windows

XBTL1003/L1004 software is used to design page contents in WYSIWYG (what you see is what you get): anything created using the software is displayed in exactly the same way on the operator dialogue terminal screen. To assist the designer, the software offers a display unit or a virtual screen depending on the type of terminal.



XBTHP

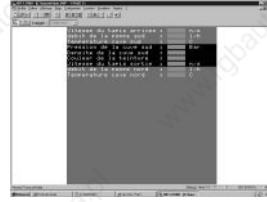

XBTE

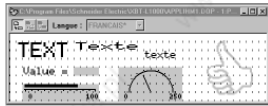

XBTHM

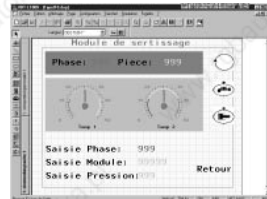

XBTF

## Model pages

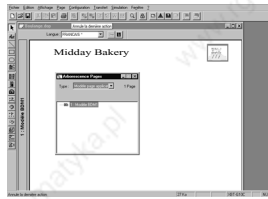

Model pages, created by the designer, are pages whose graphic format (text, images, or static objects) applies to all other pages in the same family.

There are three types of model pages:

- Application
- Alarm
- Help

Model pages are available with XBTF graphic terminals.

## Alarm pages



Alarm pages indicate any faults in the process.

The advantage of alarm pages lies in their event-triggered display:

- During operation
  - When a fault occurs, it is often the consequence of other faults. The priority levels enable the terminal to display the most important fault: the one presenting the highest risk to the process.
  - The occurrence of any fault is time and date stamped.
- During maintenance operations the terminal memorizes the faults in sequence (log) making it easy to find the cause of the fault.

## Help pages and help windows



Help pages and windows can be associated with application or alarm pages.

Help windows can be associated with any variable field.



# MAGELiS® Operator Terminals Development Software

## Software for MAGELiS Terminals

Multilingual software packages are designed for FTX 517 terminals or PC compatibles (minimum requirements: 486 processor, 66 MHz, 30 MB free space on the hard disk and either 8 MB RAM memory with a Windows 95 operating system or 16 MB RAM memory with an NT 4.0 operating system). They include the following communication protocols: UNI-TELWAY, FIPIO, FIPWAY, MODBUS, Jbus, MODBUS Plus, KS.



XBTL1003\*



XBTL1004\*

### Schneider Pack Software (with Schneider Electric Protocols)

Description	Compatibility	Operating System	Support	Documentation for alphanumeric and graphic terminals	Catalog Number	Weight lbs (kg)
Alphanumeric and graphic configuration	XBTH/P/E/HM/PM XBTF	Windows 95, 98, 2000, or NT 4.0	CD-ROM	French	XBTL1003F	3.3 (1.5)
				English	XBTL1003E	3.3 (1.5)
				German	XBTL1003G	3.3 (1.5)
				Spanish	XBTL1003S	3.3 (1.5)
				Italian	XBTL1003IT	3.3 (1.5)

*Note:* Packages contain the XBTZ915 cable and 25-pin/9-pin connection interface XBTZ962.

### Open Pack Software (with Schneider Electric and Third Party Protocols)

Description	Compatibility	Operating System	Support	Documentation	Catalog Number	Weight lbs (kg)
Alphanumeric and graphic configuration	XBTH/P/E/HM/PM XBTF	Windows 95, 98, 2000, or NT 4.0	CD-ROM	French	XBTL1004F	4.4 (2.0)
				English	XBTL1004E	4.4 (2.0)
				German	XBTL1004G	4.4 (2.0)
				Spanish	XBTL1004S	4.4 (2.0)
				Italian	XBTL1004IT	4.4 (2.0)

*Note:* Packages contain the XBTZ915 cable and 25-pin/9-pin connection interface XBTZ962.

### Schneider Update Pack with Schneider Electric Protocols

Description	Compatibility	Operating System	Support	Documentation	Catalog Number	Weight lbs (kg)
Alphanumeric and graphic configuration	XBTH/P/E/HM/PM XBTF/XBTFc	Windows 95, 98, 2000, or NT 4.0	CD-ROM	Five-language PDF format	XBTLUP1003	1.1 (0.5)

### Schneider Pack Software with Schneider Electric Protocols (Light Pack)

Description	Compatibility	Operating System	Support	Documentation	Catalog Number	Weight lbs (kg)
Alphanumeric configuration	XBTH/P/E	Windows 3.1 or Windows 95	Diskette	Ordered separately	XBTL1000	1.1 (0.5)

### Diagnostic Viewer/Remote Network Transfer Option

Description	Compatibility	Operating System	Support	Documentation	Catalog Number	Weight lbs (kg)
Alphanumeric and graphic configuration	XBTH/P/E/HM/PM XBTF/XBTFc	Windows 95, 98, 2000, or NT 4.0	CD-ROM	None	TXBTLDIAGCD M	1.1 (0.5)

- Diagnostics with PL7PRO on TSX57 Premium.
- Remote transfer over MODBUS Plus or FIPWAY.
- Dynamic database link from PL7PRO or CONCEPT to XBTL1000

For a list of Schneider Electric and third party protocols, refer to page 34.



# MAGELiS® Operator Terminals

## Separate Parts

### Downloadable protocols (onto diskettes)

PLC Brands	Compatibility	Name of Protocol	Catalog Number	Weight lb (kg)
Schneider Electric	XBTH/P/E/HM XBTF (only for XBTL1000 software)	UNI-TELWAY V1.0 UNI-TELWAY V2.0	<b>XBTL1UTW01</b>	1.43 (0.65)
		MODBUS Jbus	<b>XBTL1MOD01</b>	1.43 (0.65)
		KS	<b>XBTL1AEG01</b>	1.43 (0.65)
Allen Bradley	XBTH/P/E/HM XBTF	DF1 DH485	<b>XBTL1AB01</b>	1.43 (0.65)
GE Fanuc	XBTH/P/E	SNPX	<b>XBTL1GE01</b>	1.43 (0.65)
Omron	XBTH/P/E/HM XBTF	Sysmacway	<b>XBTL1OMR01</b>	1.43 (0.65)
Siemens	XBTH/P/E/HM XBTF	AS511 3964R	<b>XBTL1SIE03</b>	1.43 (0.65)
		PPI, MPI		1.43 (0.65)
		All 3rd party protocols	<b>XBTLPROT</b> <sup>[1]</sup>	1.1 (0.5)

[1] The software is on a CD.

### Communication on buses and networks

Type of Protocol	Compatibility	Support	Catalog Number	Weight lb (kg)
AS-i	XBTH/P/HM	Module at 22.5 intervals	<b>XBTA994</b>	0.66 (0.30)
MODBUS Plus	XBTF	Type III PCMCIA	<b>TSXMBP100</b>	2.43 (0.11)
FIPIO	XBTF	Type III PCMCIA	<b>TSXFPP10</b>	2.43 (0.11)
FIPWAY	FIPWAY on XBTF	Type III PCMCIA	<b>TSXFPP20</b>	2.43 (0.11)



XBTMEM08

### Type II PCMCIA memory cards

Size	Compatibility	Approximate Number of Pages		Catalog Number	Weight lb (kg)
		XBTF01/F032/FC02	XBTF02/F034/FC04		
8 MB	XBTF	350	230	<b>XBTMEM08</b>	0.22 (0.10)
16 MB	XBTF	720	480	<b>XBTMEM16</b>	0.22 (0.10)

Note: The XBTF terminal comes with an 8 MB PCMCIA card.

### Accessories

Type	Sold in Lots of	Compatibility	Catalog Number	Weight lb (kg)
Sheets of re-usable labels	1	XBTH02•010 XBTP01•010 XBTP02••10 XBTE XBTHM XBTF01 XBTF02	<b>XBLYH4</b> <b>XBLYP8</b> <b>XBLYP12</b> <b>XBLYE24</b> <b>XBLYHM4</b> <b>XBLYF10</b> <b>XBLYF12</b>	0.22 (0.10)
Desk holder	2	XBTF	<b>XBZ3001</b>	0.44 (0.20)
Spring clips	12	XBTHM/F	<b>XBZ3002</b>	0.44 (0.20)
	10	XBTH/P/E	<b>XBZ3003</b>	0.44 (0.20)
Power supply connector	10	XBT	<b>XBZ3004</b>	0.44 (0.20)

### Connection to PCs and printers

Use	Connection	Compatibility	Catalog Number	Weight lb (kg)
RS232C PC link (2.5 m)	9-pin (male)	Any XBT	<b>XBZ915</b>	0.44 (0.20)
Between XBZ915 cable and XBTF terminal	9-pin/25-pin	XBTF	<b>XBZ962</b>	0.22 (0.10)
Serial printer with printer port	9-pin/25-pin	Any XBT	<b>XBZ936</b>	0.44 (0.20)



## Cables for connecting MAGELiS terminals to PLCs

### Direct connection of XBTH/P/E/HM/PM/F/FC terminals to Schneider Electric PLCs



XBTZ928

Type of PLC to be Connected	Type of Connector	Physical Link	Protocol	Length ft (m)	Catalog Number	Weight lb (kg)
Nano, Micro, Premium	8-pin female mini-DIN terminal port	RS 485	UNI-TELWAY (V1.0/V2.0)	8.2 (2.5)	XBTZ968	0.40 (0.18)
				16.4 (5.0)	XBTZ9681	0.75 (0.34)
				52.5 (16.0)	XBTZ9686	1.98 (0.90)
Premium with TSXSCY2160•	25-pin female SUB-D	RS 485	UNI-TELWAY (V1.0/V2.0)	8.2 (2.5)	XBTZ918	0.51 (0.23)
Quantum	9-pin male SUB-D	RS 232	MODBUS	8.2 (2.5)	XBTZ9710	0.46 (0.21)
TSX17	15-pin female SUB-D terminal port	RS 485	UNI-TELWAY (V1.0)	16.4 (5.0)	XBTZ958	0.53 (0.24)
TSX17 with TSXSCG1161	15-pin female SUB-D	RS 485	UNI-TELWAY (V1.0)	16.4 (5.0)	XBTZ928	0.53 (0.24)
TSX Series 7 model 40 on processor	TSXLES64/74 cable connector	RS 485	UNI-TELWAY (V1.0)	16.4 (5.0)	XBTZ948	0.51 (0.23)
TSX Series 7 model 40 with TSXSCM21•6	25-pin female SUB-D	RS 485	UNI-TELWAY (V1.0)	16.4 (5.0)	XBTZ918	0.51 (0.23)
MODICON 984	9-pin male SUB-D	RS 232	MODBUS	8.2 (2.5)	XBTZ9710	0.46 (0.21)
MODICON Micro	RJ 45 male jack	RS 232	MODBUS	8.2 (2.5)	XBTZ9711	0.46 (0.21)
174CEV30010	RS 45 male jack	RS 232	MODBUS	8.2 (2.5)	XBTZ9713	0.41 (0.21)
AEG ALU	9-pin male SUB-D	RS 232	KS	8.2 (2.5)	XBTZ9712	0.46 (0.21)
AEG Micro	RJ 45 male jack	RS 232	KS	8.2 (2.5)	XBTZ9711	0.46 (0.21)
LT6	25-pin female SUB-D	RS 232	MODBUS	8.2 (2.5)	XBT9701	0.46 (0.21)

### Direct connection of XBTH/P/E/HM/PM/F/FC terminals to third-party PLCs

Type of PLC Being Connected	Type of Connector	Physical Link	Protocol	Length ft (m)	Catalog Number	Weight lb (kg)
Allen Bradley SLC5	9-pin male SUB-D	RS 232	DF1	8.2 (2.5)	XBTZ9730	0.46 (0.21)
Allen Bradley PLC5	25-pin female SUB-D	RS 232	DF1	8.2 (2.5)	XBTZ9720	0.46 (0.21)
Allen Bradley Micro-logix	Micro-logix 1000	RS 232	DF1 DH485	8.2 (2.5)	XBTZ9731 XBTZ9732	0.46 (0.21)
GE Fanuc Series 90	15-pin male SUB-D	RS 232/422	SNPX	8.2 (2.5)	XBTZ9750	0.46 (0.21)
Omron CQM1, CVM1	9-pin male SUB-D	RS 232	Systemacway	8.2 (2.5)	XBTZ9740	0.46 (0.21)
Omron CVM1	9-pin male SUB-D	RS 422	Systemacway	8.2 (2.5)	XBTZ9741	0.46 (0.21)
Siemens S7 PG	9-pin male SUB-D	RS 232	PPI	8.2 (2.5)	XBTZ9721	0.46 (0.21)
Siemens S5 CP525	25-pin female SUB-D	RS 232	3964(R)	8.2 (2.5)	XBTZ9720	0.46 (0.21)
Siemens S5 PG	15-pin female SUB-D	CL/RS 232 converter	AS511	8.2 (2.5)	XBTZ939 + XBTZ909 <sup>(1)(2)</sup>	0.48 (0.22)

<sup>(1)</sup> Order both XBTZ939 and XBTZ909 cables. <sup>(2)</sup> CL/RS232 converter XBTZ939 is only for use with Siemens PLCs.

### Bus and network connection

Type of Bus/Network	Tap-off Unit	Type of Connector	Length ft (m)	Catalog Number	Weight lb (kg)
AS-i	XBTZA994	—	8.2 (2.5)	XBTZ9702	0.44 (0.20)
UNI-TELWAY	TSXSACA62 subscriber socket	15-pin female SUB-D	5.9 (1.8)	XBTZ908	0.53 (0.24)
			8.2 (2.5)	XBTZ968	0.40 (0.18)
	TSXPACC01 cable connector	8-pin female mini-DIN	16.4 (5.0)	XBTZ9681	0.75 (0.34)
FIPIO/FIPWAY/MODBUS Plus	—	—	—	See page 36	—



# MAGELiS® Operator Terminals

## XBT-F Bus and Network Connections

### Connections to FIPIO bus, FIPWAY and MODBUS Plus networks

#### Connection to FIPIO bus

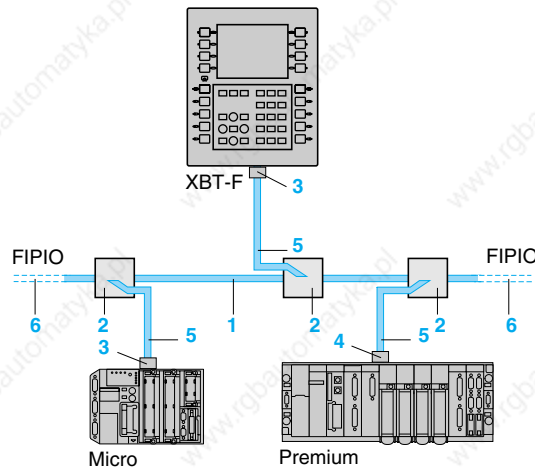

1. TSXFPCA•00: shielded twisted pair trunk cable, 150 Ω, 0.3 in. (8 mm) dia. for normal environment or indoors  
or  
TSXFPCR•00: shielded twisted pair trunk cable, 150 Ω, 0.3 in. (8 mm) dia. for harsh environment or outdoors
2. TSXFACC4: IP 65 T-junction box
3. TSXFPP10: PCMCIA card, FIPIO agent function
4. TSXFPP20: PCMCIA card, FIPIO/FIPWAY
5. TSXFPCG0•0: tap-off connecting cable for PCMCIA TSXFPP10/20 module card
6. TSXFACC7: line terminator to be placed at each segment end

#### Connection to FIPWAY network

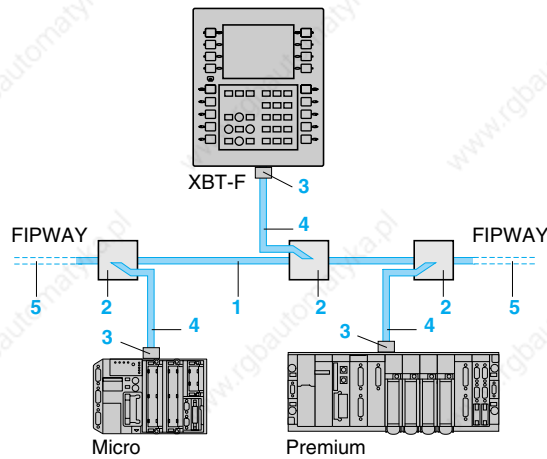

1. TSXFPCA•00: shielded twisted pair trunk cable, 150 Ω, 0.3 in. (8 mm) dia. for a normal environment or indoors  
or  
TSXFPCR•00: shielded twisted pair trunk cable, 150 Ω, 0.3 in. (8 mm) dia. for a harsh environment or outdoors
2. TSXFACC4: IP 65 T-junction box
3. TSXFPP20: PCMCIA card, FIPIO/FIPWAY
4. TSXFPCG0•0: tap-off connecting cable for PCMCIA TSXFPP10/20 module card
5. TSXFACC7: line terminator to be placed at each segment end



# MAGELiS® Operator Terminals XBTF Bus and Network Connections

## Connection to MODBUS Plus network

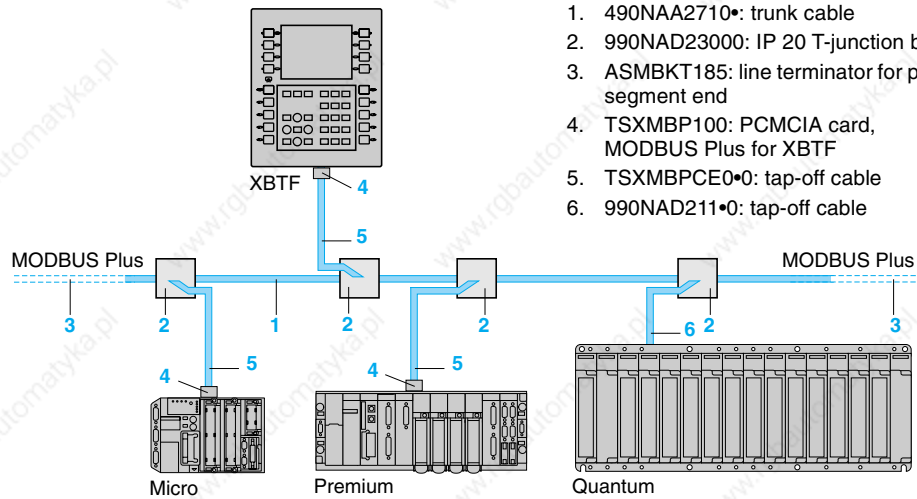

1. 490NAA2710•: trunk cable
2. 990NAD23000: IP 20 T-junction box
3. ASMBKT185: line terminator for placement at each segment end
4. TSXMBP100: PCMCIA card, MODBUS Plus for XBTF
5. TSXMBPCE0•0: tap-off cable
6. 990NAD211•0: tap-off cable

Or

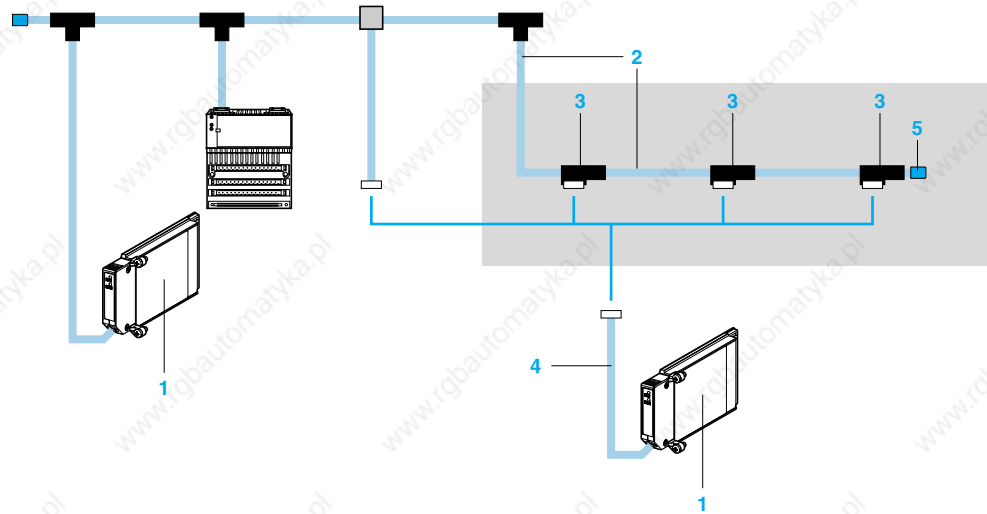

1. TSXMBP100: MODBUS Plus PCMCIA card for type III slot on Micro or Premium PLCs.
2. 170MCI020/021: tap-off cable fitted with an RJ 45 type connector at each end (basic T interface). Lengths : 0.25, 0.75, 3, or 10 m.
3. 170XTS02000: IP 20 T-junction, provides tap-off for the MODBUS Plus cable (cable equipped with RJ 45 type connector at each end). Has a 9-pin SUB-D connector for connection of the equipment.
4. TSXMBPCE002: tap-off cable for MODBUS Plus PCMCIA card, equipped with a miniature 20-pin connector on the PCMCIA side and a 9-pin SUB-D type connector on the network side. Can be used as an extension for cable 990NAD21110/30. Length: 0.2 m.
5. 170XTS02100: set of 2 line terminators (impedance matching) for T-junction 170XTS02000, to be placed at each segment end



# MAGELiS® Operator Terminals

## XBTF Bus and Network Connections



TSX FPP 0



TSX FP ACC 4



TSX FP ACC 7



TSX FP CG 00



TSX MBP 100



TSX MBP CE 0\*0

### FIPWAY network/FIPIO bus connection cables and accessories <sup>(1)</sup>

Description	Type	Condition of use	Length ft (m)	Catalog Number	Weight lb (kg)
FIPIO PCMCIA card	Agent function	FIPIO on XBTF	—	TSXFPP10	0.24 (0.11)
FIPWAY PCMCIA card	—	FIPWAY on XBTF	—	TSXFPP20	0.24 (0.11)
Trunk cables	8 mm, 1 shielded twisted pair 150 Ω	In normal environment <sup>(2)</sup> and indoors	328 (100)	TSXFPCA100	12.52 (5.68)
			656 (200)	TSXFPCA200	24.07 (10.92)
			1640 (500)	TSXFPCA500	66.14 (30.00)
	8 mm, 1 shielded twisted pair 150 Ω	In harsh environment <sup>(3)</sup> outdoors or in a daisy-chain <sup>(4)</sup>	328 (100)	TSXFPCR100	16.93 (7.68)
			656 (200)	TSXFPCR200	32.89 (14.92)
			1640 (500)	TSXFPCR500	88.18 (40.00)
Dust and damp-proof junction box	Zamac, IP 65	Trunk cable tap link	—	TSXFPACC4	1.46 (0.66)
Line terminators (sold in lots of 2)	—	—	—	TSXFPACC7	0.04 (0.02)

#### Tap-off connection cables

Description	Use		Length ft (m)	Catalog Number	Weight lb (kg)
	From	To			
Cables for PCMCIA card	TSXFPP10/20 card	TSXFPACC4 junction box	3 <sup>(1)</sup>	TSXFPCCG010	0.46 (0.21)
			10 <sup>(3)</sup>	TSXFPCCG030	0.90 (0.41)

<sup>(1)</sup> The specifications and performance of the FIPIO bus or FIPWAY network depend on the use of these TSXFP accessories.

<sup>(2)</sup> Normal environment:  
 — no special environmental constraints  
 — operating temperature between +5 °C and +60 °C  
 — fixed installations

<sup>(3)</sup> Harsh environment:  
 — resistance to hydrocarbons, industrial oils, detergents and solder chips  
 — relative humidity up to 100%  
 — saline environment  
 — extreme variations in temperatures  
 — operating temperature between -10 °C and +70 °C  
 — mobile installations

<sup>(4)</sup> Use in a daisy-chain: radius of curvature = 10 x cable diameter, either 3.1 or 3.7 in. (80 or 95 mm). For other special restrictions, please consult your regional sales office.

### MODBUS Plus network connection cables and accessories

Description	Use	Catalog Number	Weight lb (kg)
MODBUS Plus PCMCIA card	XBTF	TSXMBP100	0.24 (0.11)
MODBUS Plus junction box	IP 20 T-junction box	990NAD23000	0.51 (0.23)
Line terminators (sold in lots of 2)	—	ASMBKT185	—

#### Connection cables

Description	Use		Length ft (m)	Catalog Number	Weight lb (kg)
	From	To			
MODBUS Plus trunk cables	Junction box	Junction box	98 (30)	490NAA27101	—
			492 (150)	490NAA27102	—
			984 (300)	490NAA27103	—
			1476 (450)	490NAA27104	—
			4921 (1500)	490NAA27106	—
Tap-off cables	TSXMBP100 PCMCIA card	990NAD23000 junction box	10 (3)	TSXMBPCE030	0.75 (0.34)
			20 (6)	TSXMBPCE060	1.17 (0.53)
	Quantum PLC	990NAD23000 junction box	0.2 (0.06)	TSXMBPCE002	—
			7.9 (2.4)	990NAD21110	1.17 (0.53)
			20 (6)	990NAD21130	1.17 (0.53)



# MAGELiS® Operator Terminals Wiring Diagrams

The following information provides specific details for one electrical connection and two serial communication ports of the XBT terminals. Figure 1 shows the location of the electrical connection and the serial communications ports.

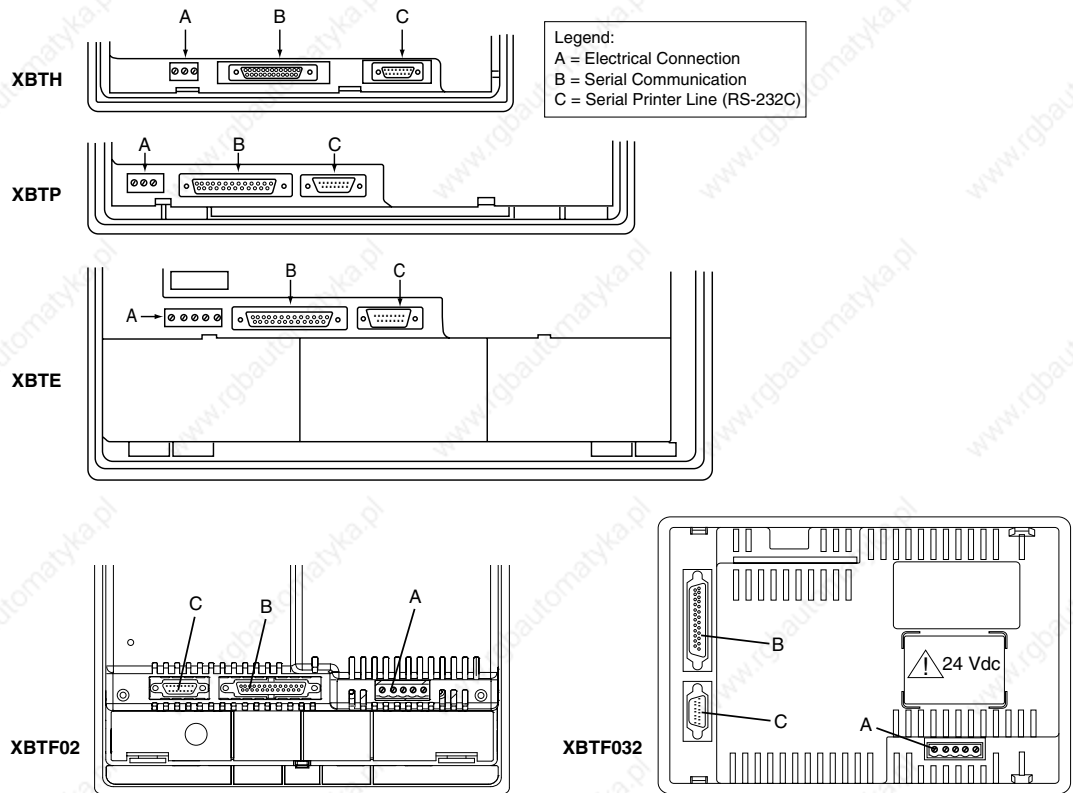

**Figure 1: Electrical Connections and Serial Communications**

## Electrical Connections

The power supply connections and the XBTE relay connections should be made following the connection schemes shown in Figure 2.

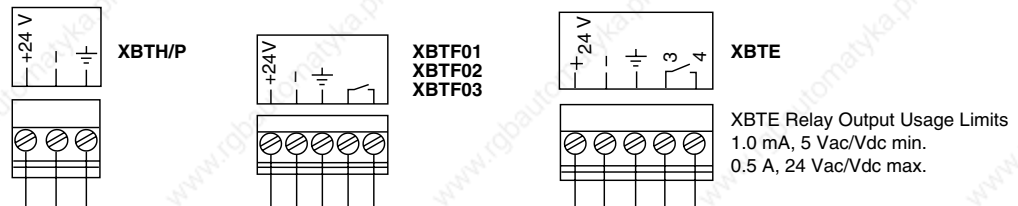

	XBTH/P	XBTHM/PM	XBTF	XBTE	
				FLUO	LCD
Maximum Consumption	10 W	15 W	35 W	20 W	10 W
Nominal Voltage	24 Vdc				
Voltage Limits (including ripple)	18–30 V				

**Figure 2: Electrical Connections**



# MAGELiS® Operator Terminals

## Wiring Diagrams

### Serial communication

Figures 3 and 4 show the pin arrangements of the the serial communication link and the serial printer link.

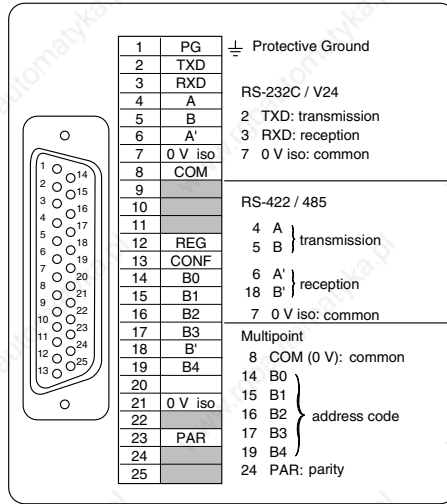

Figure 3: Serial Communication Link

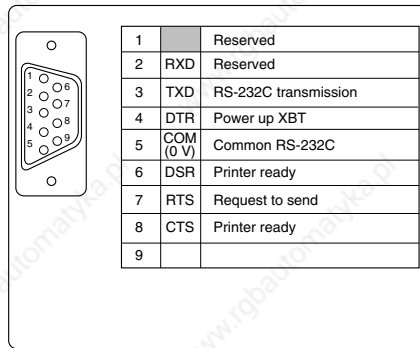

Figure 4: Serial Printer Link



# MAGELiS® Operator Terminals Wiring Diagrams

## Cable Pinouts

The following pages show cable pinout diagrams for XBT MAGELiS terminal cables.

### MAGELiS to PC (XBTZ915) Cable

XBTZ915 Cable, Version 2.2  
8.2 ft (2.5 meters)

MAGELiS XBT  
SUB-D 25-pin male

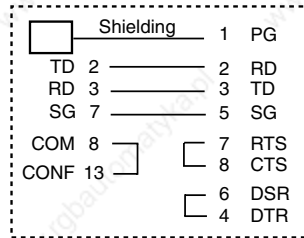
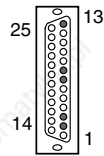

PC  
SUB-D 9-pin female

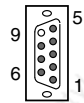

### MAGELiS XBTZ962 Adapter/Application Transfer XBTF



XBTZ915  
SUB-D 25-pin female

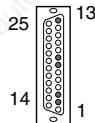

XBTZ962 Adapter

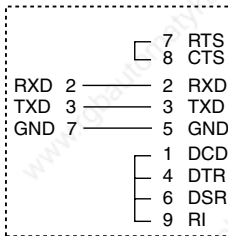

XBTF  
SUB-D 9-pin female



XBTF

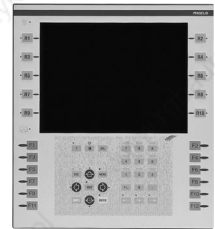

### TSX Nano/TSX Micro/TSX Premium to MAGELiS (XBTZ968•) Cable

XBT-Z968 Cable, 8.2 ft (2.5 meters) V 1.2  
XBT-Z9681 Cable, 16.4 ft (5 meters) V 1.2

TSX07/37/57  
Mini DIN 8-pin male  
programming port

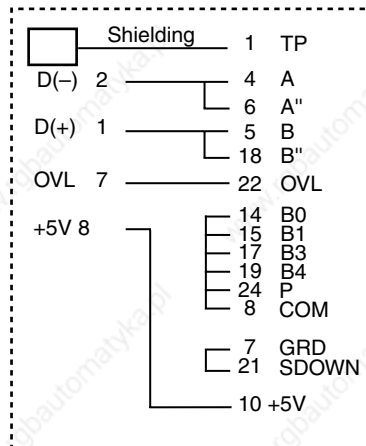

XBT  
SUB-D 25-pin male

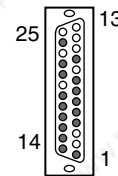

# MAGELiS® Operator Terminals Wiring Diagrams

## MODICON Micro/TSX Compact/MOMENTUM to MAGELiS Cable

Modicon Micro/TSX Compact (MODBUS Port) to XBT cable  
(XBTZ9711)

MAGELiS XBT  
SUB-D 25-pin male

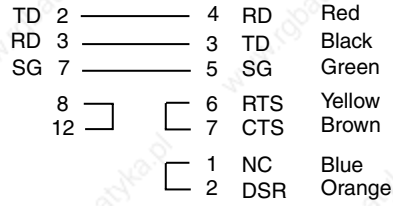
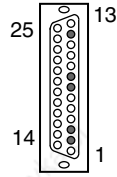

Modular Jack  
RJ45

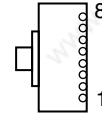

## Compact 984 (984-120/130-131/141-145/241-245) MODBUS Port to MAGELiS Cable

Compact 984 to XBT Cable  
(XBTZ9710)

MAGELiS XBT  
SUB-D 25-pin male

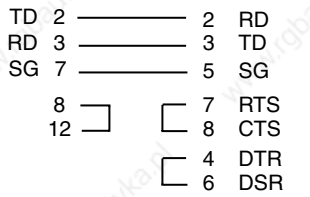
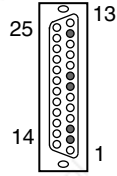

Compact 984  
SUB-D 9-pin male

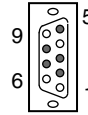

# MAGELiS® Operator Terminals Wiring Diagrams

## Quantum (MODBUS Port) to MAGELiS Cable

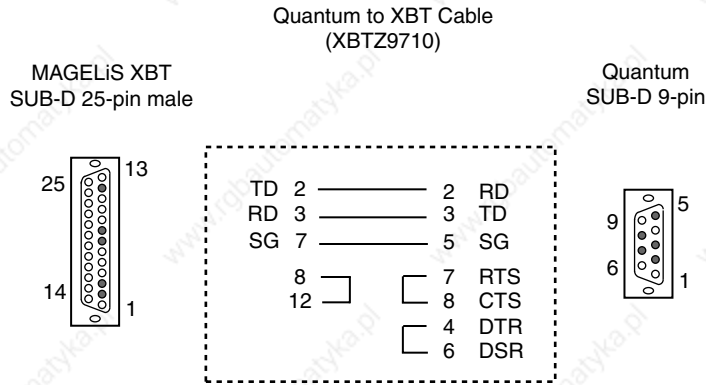

## MAGELiS to MODICON Cable (RS-232 C, with MODBUS Protocol)

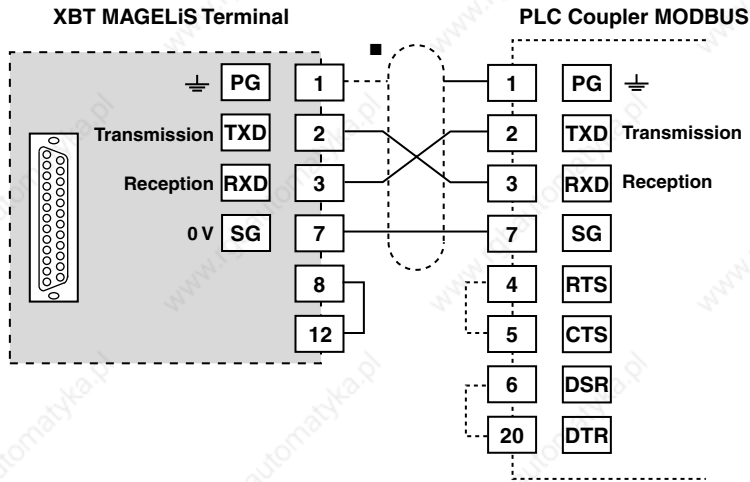

In some configurations, it is not necessary to reverse pins 2 and 3. Consult the appropriate PLC documentation.



# MAGELiS® Operator Terminals Wiring Diagrams

## MAGELiS to MODICON Cable (RS-422/485, with MODBUS Protocol)

### RS 422 LINK

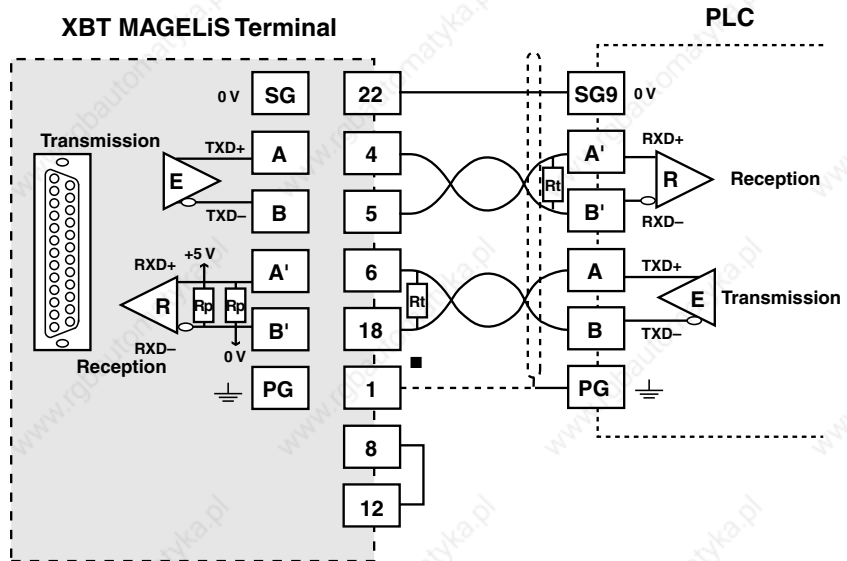

### RS 485 LINK

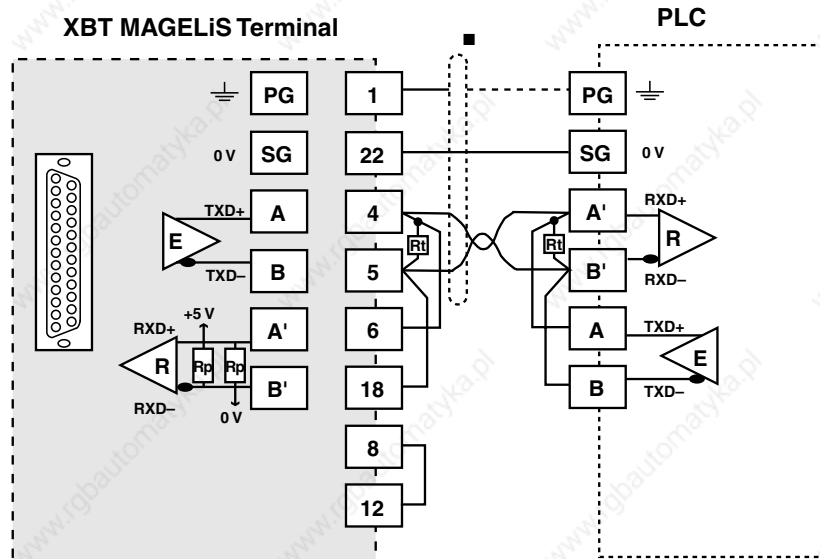

■ Connection of shielding to both cable ends depends on the electrical operating conditions.

Rt: Link termination resistor (normally 110 Ω).

NOTE: The Rp resistors (4.7 kΩ) are integrated in the XBT.



# MAGELiS® Operator Terminals Wiring Diagrams

## MAGELiS (XBTZ9720) to Siemens Cable (RS-232 C, with 3964/3964R Protocol)

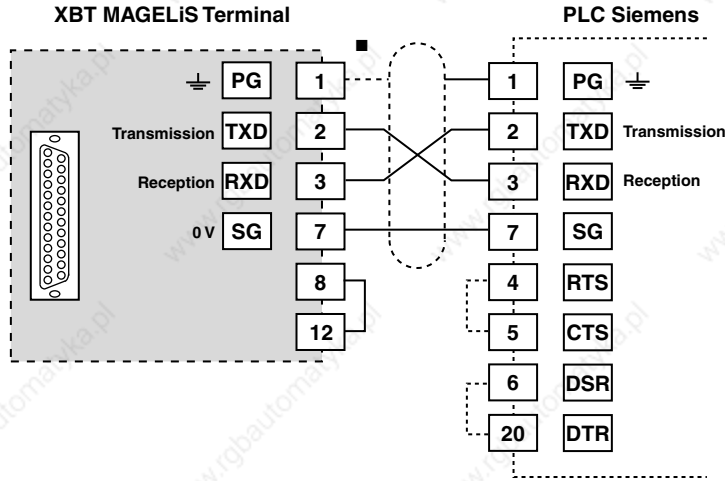

■ Connection of shielding to both cable ends depends on the electrical constraints of the installation.

In some configurations, it is not necessary to reverse pins 2 and 3. Consult the appropriate PLC documentation.

## MAGELiS (XBTZ939 and XBTZ909) to Siemens Cable (RS-232 C, with AS 511 Protocol)

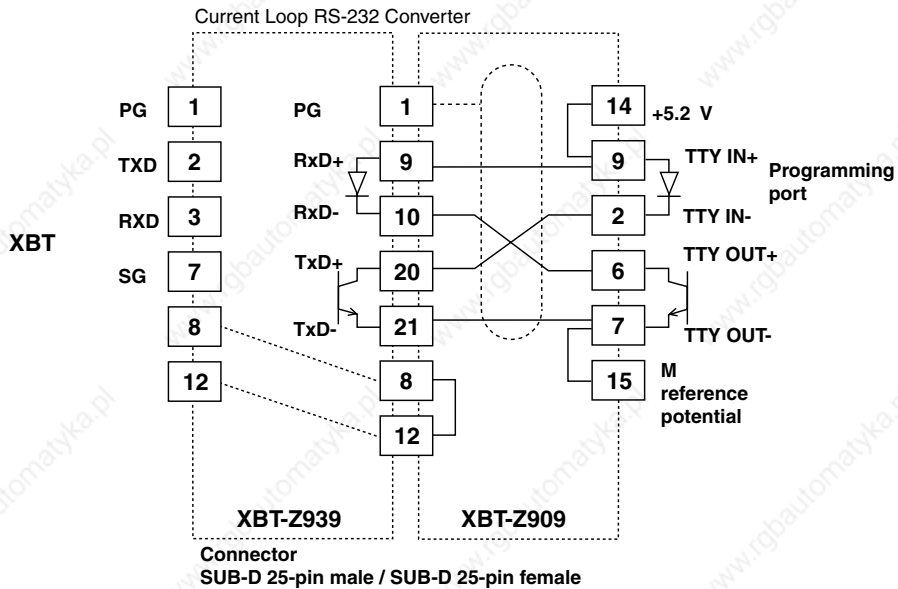

# MAGELiS® Operator Terminals

## Wiring Diagrams

### MAGELiS to Siemens Cable (RS-422, with 3964/3964R Protocol)

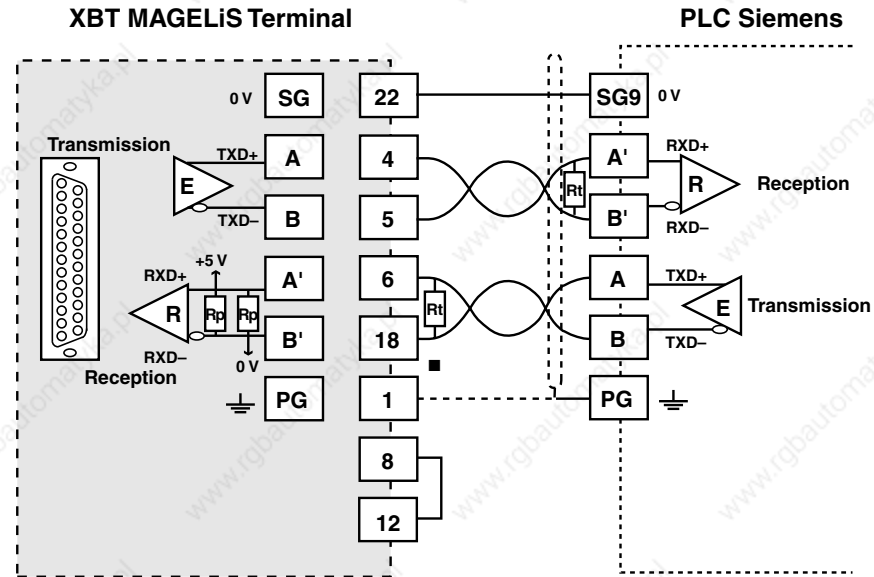

■ Connection of shielding to both cable ends depends on the electrical operating conditions.

Rt: Link termination resistor (normally 110 Ω).

NOTE: The Rp resistors (4.7 kΩ) are integrated in the XBT.

### MAGELiS (XBTZ9721) to Siemens Cable (PP1 RS-485)

Siemens  
SUB-D 9-pin male

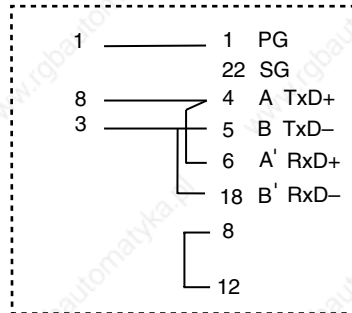
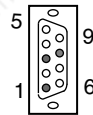

MAGELiS XBT  
SUB-D 25-pin male

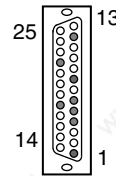

# MAGELiS® Operator Terminals Wiring Diagrams

## MAGELiS (XBTZ9720) to Allen Bradley Cable (RS-232 C)

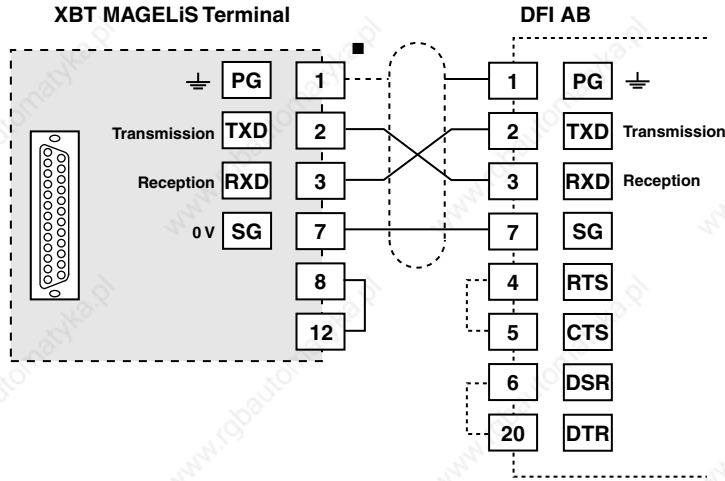

■ Connection of shielding to both cable ends depends on the electrical constraints of the installation. In some configurations, it is not necessary to reverse pins 2 and 3. Consult the appropriate PLC documentation.

## MAGELiS (XBTZ9731) to Allen Bradley Cable (Micro-logix)

AB DF1  
Mini DIN 8-pin

MAGELiS XBT  
SUB-D 25-pin male

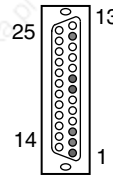
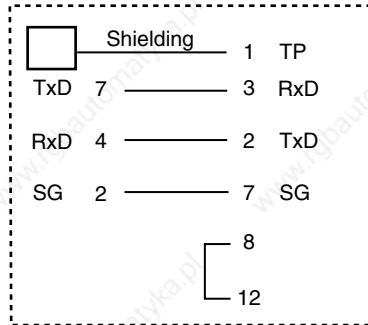
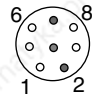

# MAGELiS® Operator Terminals Wiring Diagrams

## MAGELiS (XBTZ9730) to Allen Bradley Cable (SLC5)

AB DF1  
SUB-D 9-pin

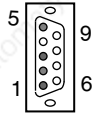

MAGELiS XBT  
SUB-D 25-pin male

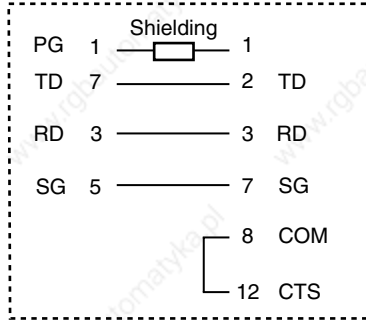
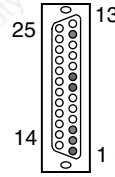

# MAGELiS® Operator Terminals Wiring Diagrams

## MAGELiS (XBTZ9740) to Omron Cable (RS-232 C)

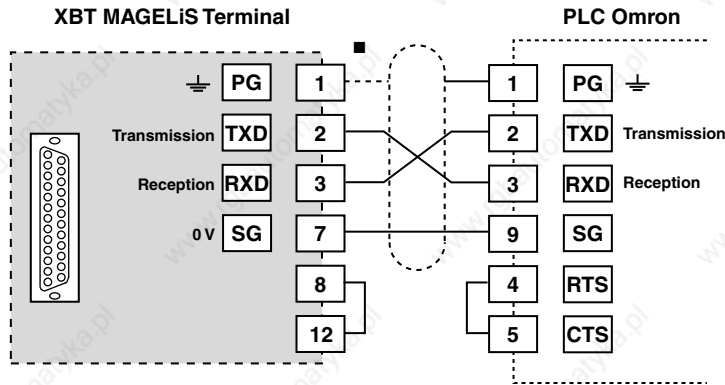

■ Connection of shielding to both cable ends depends on the electrical operating conditions.  
The Omron connector is a DB9 type.

## MAGELiS (XBTZ9741) to Omron Cable (RS-422)

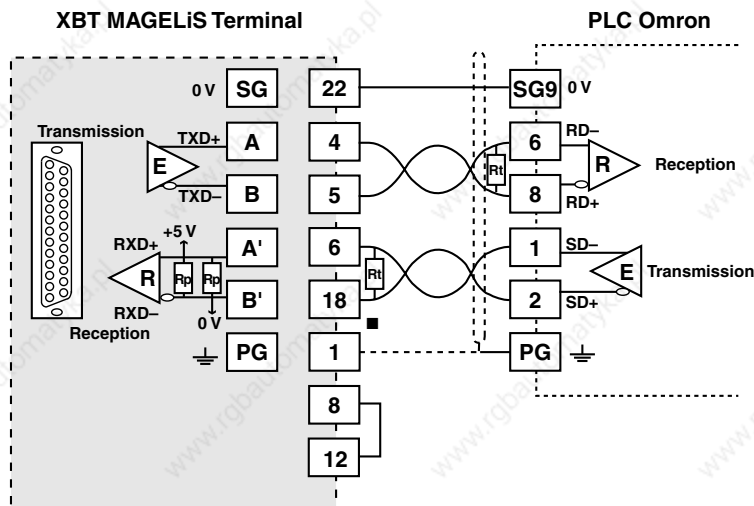

■ Connection of shielding to both cable ends depends on the electrical operating conditions.

Rt: Link termination resistor (normally 110 Ω).

NOTE: The Rp resistors (4.7 kΩ) are integrated in the XBT.



# MAGELiS® Operator Terminals Wiring Diagrams

## MAGELiS (XBTZ9750) to GE Fanuc Cable

GE-FANUC  
SUB-D 9-pin male

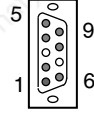

MAGELiS XBT  
SUB-D 25-pin male

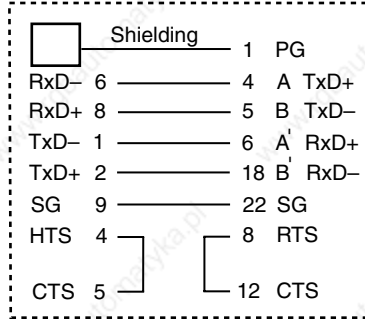
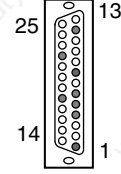

# MAGELiS® Operator Terminals Dimensions

## Displays and Terminals

### XBTH

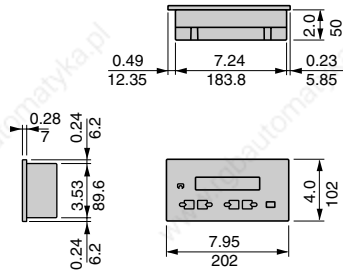

### Mounting Panel Cutout

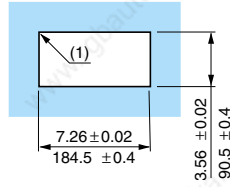

### XBTP

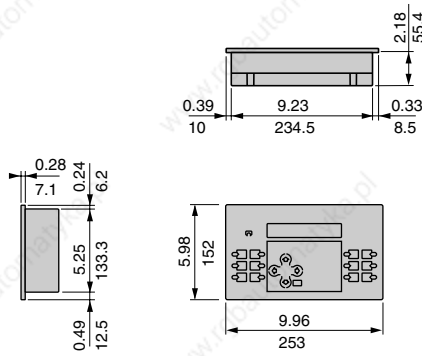

### Mounting Panel Cutout

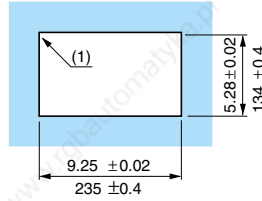

### XBTE

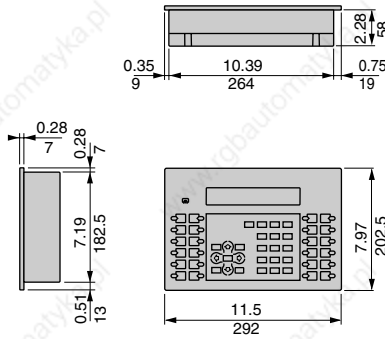

### Mounting Panel Cutout

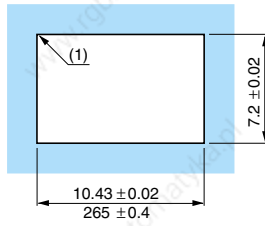

### XBTHM

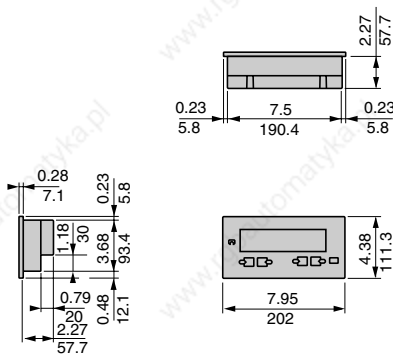

### Mounting Panel Cutout

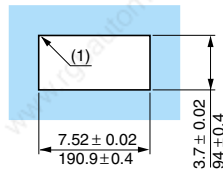

(1) r = 0.08–0.14 in. (2–3.5 mm)

Dual Dimensions  $\frac{\text{inches}}{\text{mm}}$



# MAGELiS® Operator Terminals

## Dimensions

### Terminals with Graphic Screens

#### XBTF011•10

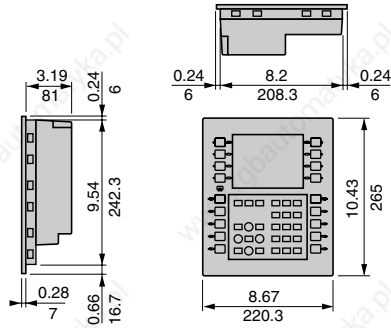

#### Mounting Panel Cutout

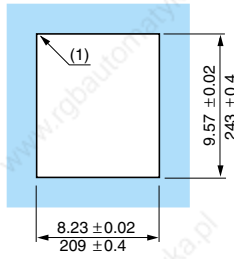

#### XBTF032•10

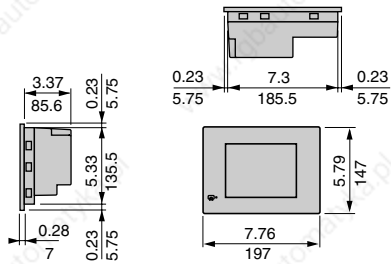

#### Mounting Panel Cutout

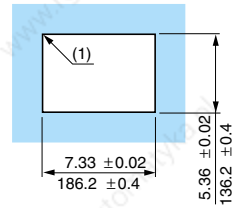

#### XBTF023/F024

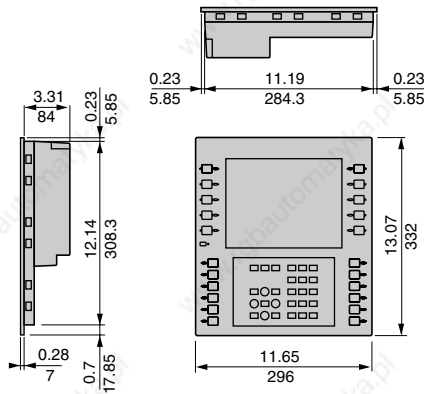

#### Mounting Panel Cutout

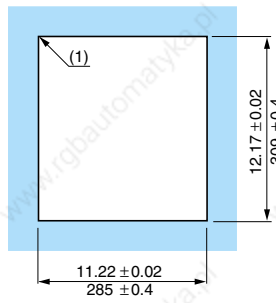

#### XBTF034

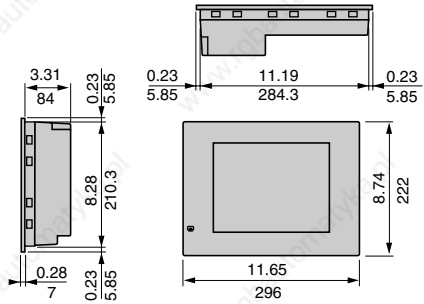

#### Mounting Panel Cutout

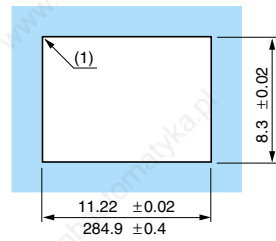

(1)  $r = 0.08\text{--}0.14$  in. (2–3.5 mm)

Dual Dimensions  $\frac{\text{inches}}{\text{mm}}$









Square D Company  
8001 Highway 64 East  
Knightdale NC 27545  
1-888-SquareD  
(1-888-778-2733)  
[www.squared.com](http://www.squared.com)

Schneider Canada Inc.  
19 Waterman Avenue,  
M4B 1 Y2  
Toronto, Ontario  
1-800-565-6699  
[www.schneider-electric.ca](http://www.schneider-electric.ca)

Catalog No. 9001CT9802R4/01 May 2001 © 1999–2001 Schneider Electric All Rights Reserved  
Replaces 9001CT9802R3/00 dated 7/00.