

Industry's Lowest-Power Ambient Light Sensor with ADC

General Description

The MAX44009 ambient light sensor features an I²C digital output that is ideal for a number of portable applications such as smartphones, notebooks, and industrial sensors. At less than 1 μ A operating current, it is the lowest power ambient light sensor in the industry and features an ultra-wide 22-bit dynamic range from 0.045 lux to 188,000 lux.

Low-light operation allows easy operation in dark-glass applications.

The on-chip photodiode's spectral response is optimized to mimic the human eye's perception of ambient light and incorporates IR and UV blocking capability. The adaptive gain block automatically selects the correct lux range to optimize the counts/lux.

The IC is designed to operate from a 1.7V to 3.6V supply voltage range and consumes only 0.65 μ A in full operation. It is available in a small, 2mm x 2mm x 0.6mm UTDFN-Opto package.

Applications

Tablet PCs/Notebook Computers
TVs/Projectors/Displays
Digital Lighting Management
Portable Devices
Cellular Phones/Smartphones
Security Systems

Features

- ◆ Wide 0.045 Lux to 188,000 Lux Range
- ◆ Small, 2mm x 2mm x 0.6mm UTDFN-Opto
- ◆ VCC = 1.7V to 3.6V
- ◆ I_{CC} = 0.65 μ A Operating Current
- ◆ -40°C to +85°C Temperature Range
- ◆ Device Address Options
1001 010x and 1001 011x

Ordering Information

PART	PIN-PACKAGE	TEMP RANGE
MAX44009EDT+	6 UTDFN-Opto-EP*	-40°C to +85°C

+Denotes a lead(Pb)-free/RoHS-compliant package.

*EP = Exposed pad.

Block Diagram

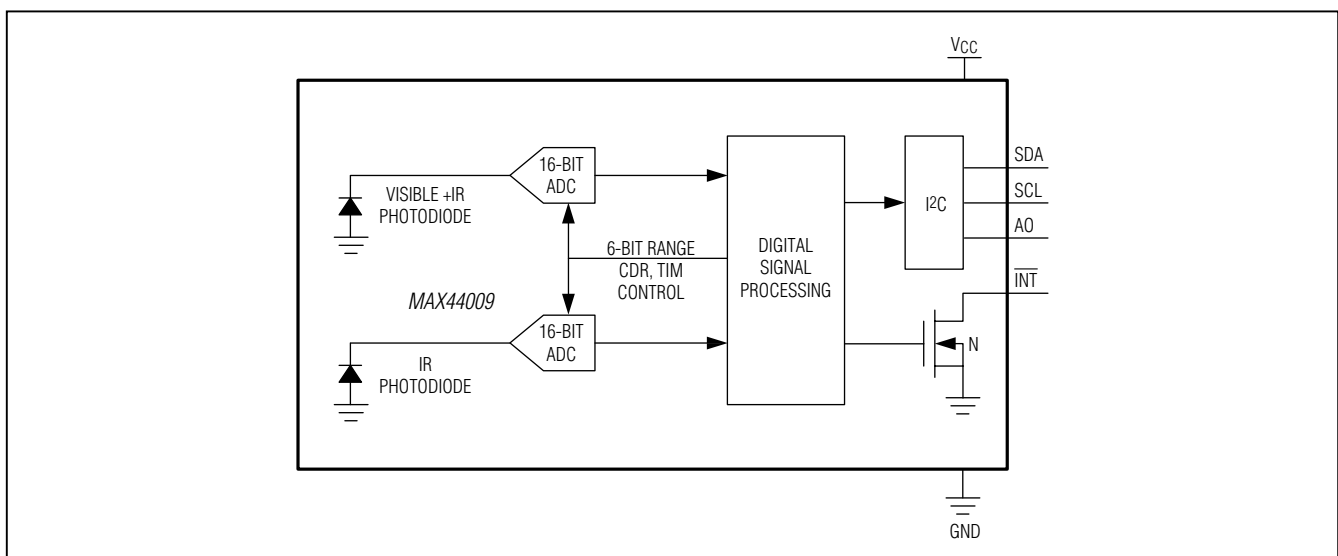

For pricing, delivery, and ordering information, please contact Maxim Direct at 1-888-629-4642, or visit Maxim's website at www.maximintegrated.com.

MAX44009

Industry's Lowest-Power Ambient Light Sensor with ADC

ABSOLUTE MAXIMUM RATINGS

$\overline{\text{INT}}$ to GND.....	-0.3V to ($V_{CC} + 0.3V$)	Continuous Input Current into Any Terminal.....	$\pm 20\text{mA}$
All Other Pins to GND	-0.3V to +4V	Continuous Power Dissipation	
$\overline{\text{INT}}$ Short-Circuit Current Duration	10s	6 UTDFN-Opto (derate 11.9mW/°C above +70°C).....	953mW
All Other Pins Short-Circuit Current Duration.....	Continuous	Operating Temperature Range.....	-40°C to +85°C

Stresses beyond those listed under "Absolute Maximum Ratings" may cause permanent damage to the device. These are stress ratings only, and functional operation of the device at these or any other conditions beyond those indicated in the operational sections of the specifications is not implied. Exposure to absolute maximum rating conditions for extended periods may affect device reliability.

ELECTRICAL CHARACTERISTICS

($V_{CC} = 1.8V$, T_{MIN} to $T_{MAX} = -40^{\circ}\text{C}$ to $+85^{\circ}\text{C}$, unless otherwise noted.) (Note 1)

PARAMETER	SYMBOL	CONDITIONS	MIN	TYP	MAX	UNITS
OPTICAL CHARACTERISTICS						
Maximum Lux Sensitivity		Fluorescent light		0.045		Lux/LSB
Saturation Ambient Lux Level		Sunlight		188,000		Lux
Total Error	TE	Green LED 538nm response, $T_A = +25^{\circ}\text{C}$ (Note 2)			15	%
Light Source Matching		Fluorescent/incandescent light		10		%
Infrared Transmittance at 940nm	IRR	$T_A = +25^{\circ}\text{C}$ (Note 3)		0	0.5	%
Ultraviolet Transmittance at 363nm	UVR	$T_A = +25^{\circ}\text{C}$ (Note 3)		1.2		%
Dark Level Count	0LUX	0 lux, $T_A = +25^{\circ}\text{C}$, 800ms range		0	0.045	Lux
Maximum Signal Integration Time		Has 50/60Hz rejection		800		ms
Minimum Signal Integration Time		Automatic mode, has 50/60Hz rejection		100		ms
		Manual mode only		6.25		
ADC Conversion Time	ACT	100ms range, $T_A = +25^{\circ}\text{C}$	99.6	100	100.4	ms
		100ms range	97	103	107	
POWER SUPPLY						
Power-Supply Voltage	V_{CC}	Guaranteed by TE test	1.7		3.6	V
Power-Supply Current	I_{CC}	$T_A = +25^{\circ}\text{C}$, 90 lux, I ² C inputs inactive		0.65	1.2	μA
		$T_A = -40^{\circ}\text{C}$ to $+85^{\circ}\text{C}$			1.6	
DIGITAL I/O CHARACTERISTICS						
Output Low Voltage SDA, $\overline{\text{INT}}$	V_{OL}	$I_{SINK} = 6\text{mA}$		0.06	0.4	V
$\overline{\text{INT}}$ Leakage Current		$T_A = +25^{\circ}\text{C}$		0.01	20	nA
SCL, SDA, A0 Input Current	I_{IH} , I_{IL}	$T_A = +25^{\circ}\text{C}$		0.01	20	nA
I ² C Input Low Voltage	V_{IL_I2C}	SDA, SCL			0.3 x V_{CC}	V
I ² C Input High Voltage	V_{IH_I2C}	SDA, SCL	0.7 x V_{CC}			V
Address Input Low Voltage	V_{IL_A0}	A0			0.3	V
Address Input High Voltage	V_{IH_A0}	A0	$V_{CC} - 0.3V$			V
Input Capacitance				3		pF