

## PERFORMANCE SPECIFICATIONS

Supply Current: 1.5mA

Ambient Temperature: 25°C (unless otherwise specified)

PARAMETERS	MIN	TYP	MAX	UNITS	NOTES
Span	75	100	150	mV	1
Span (2psi version)	30		60	mV	1
Zero Pressure Output	-2		2	mV	
Pressure Non Linearity	-0.1	±0.05	0.1	%Span	2
Pressure Hysteresis	-0.05	±0.01	0.05	%Span	
Input & Output Resistance	2500	4400	6000	Ω	
Temperature Error – Span	-0.5	±0.3	0.5	%Span	3
Temperature Error – Zero	-0.5	±0.1	0.5	%Span	3
Thermal Hysteresis – Zero		±0.1		%Span	3
Supply Current		1.5	2.0	mA	
Response Time (10% to 90%)		1.0		mS	4
Output Noise (10Hz to 1kHz)		1.0		μV p-p	
Insulation Resistance (50 Vdc)	50			M Ω	5
Long Term Stability (Offset & Span)		±0.2		%Span	6
Pressure Overload			3X	Rated	7
Compensated Temperature	0		50	°C	
Operating Temperature	-40		+125	°C	
Storage Temperature	-50		+150	°C	
Weight			3	grams	
Solder Temperature	250°C Max 5 Sec.				
Media	Non-Corrosive Dry Gases Compatible with Silicon, Pyrex, RTV, Gold, Nickel, and Aluminum				

## Notes

1. Ratiometric to supply current.
2. Best fit straight line.
3. Maximum temperature error between 0°C and 50°C with respect to 25°C. For 2 psi devices, Temperature Error – Zero is ±1.25%.
4. For a zero-to-full scale pressure step change.
5. Minimum resistance between case and pins.
6. Long term stability over a one year period with constant current and temperature.
7. For topside applications, 2X maximum for 250 psi device, 20 psi maximum for 2 and 5 psi devices. For backside applications, 3X not to exceed 100 psi on all ranges.

## DIMENSIONS

DIMENSIONS ARE IN INCHES [mm]

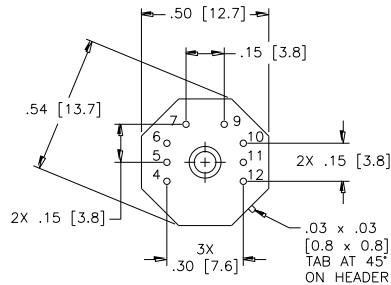
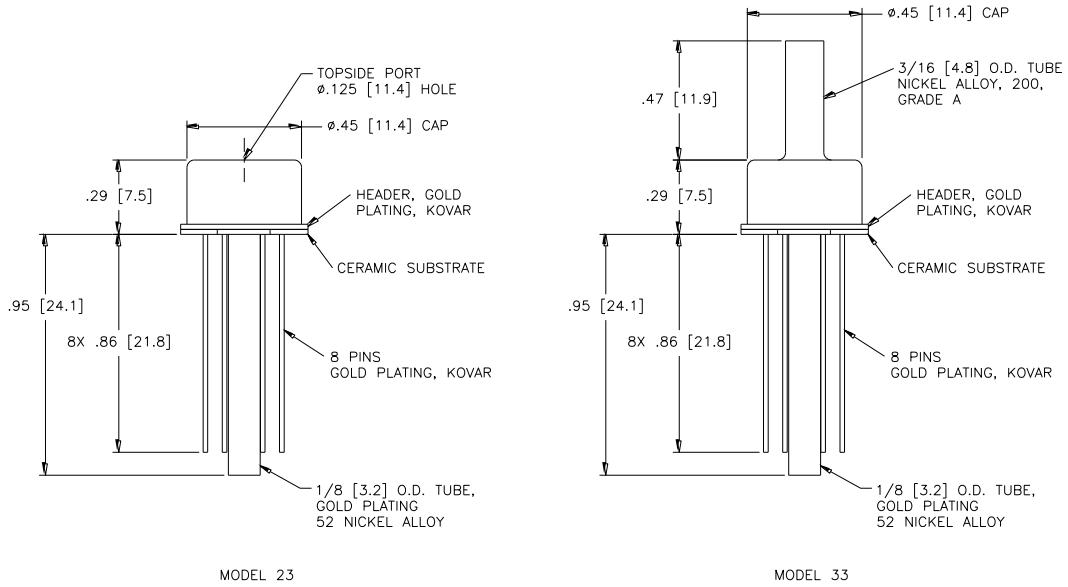

## CONNECTIONS

