

This manual includes information on:

- Control Panel
- Application macros (including the I/O channel wiring diagrams)
- Parameters
- Fault tracing
- Fieldbus control

## Standard Application Program 6.x

for ACS 600 Frequency Converters





# Standard Application Program 6.x

for ACS 600 Frequency Converters

## **Firmware Manual**

3AFY 61201441 R0725 EN  
EFFECTIVE: 16.10.2000  
SUPERSEDES: 06.09.1999



# Safety Instructions

---

## Overview

This chapter states the safety instructions which must be followed when installing, operating and servicing the ACS 600. If neglected, physical injury and death may follow, or damage may occur to the frequency converter, the motor and driven equipment. The material in this chapter must be studied before attempting any work on, or with, the unit.

## Warnings and Notes

This manual distinguishes two sorts of safety instructions. Warnings are used to inform of conditions which can, if proper steps are not taken, lead to a serious fault condition, physical injury and death. Notes are used when the reader is required to pay special attention or when there is additional information available on the subject. Notes are less crucial than Warnings, but should not be disregarded.

### Warnings

Readers are informed of situations that can result in serious physical injury and/or serious damage to equipment with the following symbols:



**Dangerous Voltage Warning:** warns of situations in which a high voltage can cause physical injury and/or damage equipment. The text next to this symbol describes ways to avoid the danger.



**General Warning:** warns of situations which can cause physical injury and/or damage equipment by means other than electrical. The text next to this symbol describes ways to avoid the danger.



**Electrostatic Discharge Warning:** warns of situations in which an electrostatic discharge can damage equipment. The text next to this symbol describes ways to avoid the danger.

### Notes

Readers are notified of the need for special attention or additional information available on the subject with the following symbols:

#### CAUTION!

**Caution** aims to draw special attention to a particular issue.

#### Note:

**Note** gives additional information or points out more information available on the subject.

## General Safety Instructions

These safety instructions are intended for all work on the ACS 600. In addition to the instructions given below, there are more safety instructions on the first pages of the appropriate hardware manual.

---



**WARNING!** All electrical installation and maintenance work on the ACS 600 should be carried out by qualified electricians.

The ACS 600 and adjoining equipment must be properly earthed.

Do not attempt any work on a powered ACS 600. After switching off the mains, always allow the intermediate circuit capacitors 5 minutes to discharge before working on the frequency converter, the motor or the motor cable. It is good practice to check (with a voltage indicating instrument) that the frequency converter is in fact discharged before beginning work.

The ACS 600 motor cable terminals are at a dangerously high voltage when mains power is applied, regardless of motor operation.

There can be dangerous voltages inside the ACS 600 from external control circuits when the ACS 600 mains power is shut off. Exercise appropriate care when working with the unit. Neglecting these instructions can cause physical injury and death.

---



**WARNING!** The ACS 600 introduces electric motors, drive train mechanisms and driven machines to an extended operating range. It should be determined from the outset that all equipment is up to these conditions.

Operation is not allowed if the motor nominal voltage is less than one half of the ACS 600 nominal input voltage, or the motor nominal current is less than 1/6 of the ACS 600 nominal output current. Proper attention should be given to the motor insulation properties. The ACS 600 output comprises of short, high voltage pulses (approximately 1.35 ... 1.41 · mains voltage) regardless of output frequency. This voltage can be almost doubled by unfavourable motor cable properties. Contact an ABB office for additional information if multimotor operation is required. Neglecting these instructions can result in permanent damage to the motor.

All insulation tests must be carried out with the ACS 600 disconnected from the cabling. Operation outside the rated capacities should not be attempted. Neglecting these instructions can result in permanent damage to the ACS 600.

There are several automatic reset functions in the ACS 600. If selected, they reset the unit and resume operation after a fault. These functions should not be selected if other equipment is not compatible with this kind of operation, or dangerous situations can be caused by such action.

---

# Table of Contents

---

## **Safety Instructions**

## **Table of Contents**

### **Chapter 1 – Introduction to This Manual**

Overview .....	1-1
Before You Start .....	1-1
What This Manual Contains .....	1-1
Related Publications .....	1-2

### **Chapter 2 – Overview of ACS 600 Programming and the CDP 312 Control Panel**

Overview .....	2-1
ACS 600 Programming .....	2-1
Application Macros .....	2-1
Parameter Groups .....	2-1
Control Panel .....	2-1
Panel Operation .....	2-4
Keypad Modes .....	2-4
Identification Display .....	2-4
Actual Signal Display Mode .....	2-4
Parameter Mode .....	2-8
Function Mode .....	2-9
Drive Selection Mode .....	2-12
Operational Commands .....	2-13
Reading and Entering Packed Boolean Values on the CDP 312 .....	2-14

### **Chapter 3 – Start-up Data**

Overview .....	3-1
Start-up Data Parameters .....	3-1
ID Run Procedure .....	3-5

### **Chapter 4 – Control Operation**

Overview .....	4-1
Actual Signals .....	4-1
Group 1 Actual Signals .....	4-1
Group 2 Actual Signals .....	4-3
Group 3 Actual Signals .....	4-4
Fault History .....	4-4
Local Control vs. External Control .....	4-4

Local Control . . . . .	4-5
External Control . . . . .	4-5

**Chapter 5 – Standard Application Macro Programs**

Overview . . . . .	5-1
Application Macros . . . . .	5-1
User Macros . . . . .	5-2
Application Macros Overview . . . . .	5-3
Application Macro 1 – Factory . . . . .	5-4
Operation Diagram . . . . .	5-4
Input and Output Signals . . . . .	5-4
External Connections . . . . .	5-5
Control Signal Connections . . . . .	5-6
Application Macro 2 – Hand/Auto . . . . .	5-7
Operation Diagram . . . . .	5-7
Input and Output Signals . . . . .	5-7
External Connections . . . . .	5-8
Control Signal Connections . . . . .	5-9
Application Macro 3 – PID Control . . . . .	5-10
Operation Diagram . . . . .	5-10
Input and Output Signals . . . . .	5-10
External Connections . . . . .	5-11
Control Signal Connections . . . . .	5-12
Application Macro 4 – Torque Control . . . . .	5-13
Operation Diagram . . . . .	5-13
Input and Output Signals . . . . .	5-13
External Connections . . . . .	5-14
Control Signal Connections . . . . .	5-15
Application Macro 5 – Sequential Control . . . . .	5-16
Operation Diagram . . . . .	5-16
Input and Output Signals . . . . .	5-17
External Connections . . . . .	5-18
Control Signal Connections . . . . .	5-19

**Chapter 6 – Parameters**

Overview . . . . .	6-1
Parameter Groups . . . . .	6-1
Group 10 Start/Stop/Dir . . . . .	6-2
Group 11 Reference Select . . . . .	6-5
Group 12 Constant Speeds . . . . .	6-11
Group 13 Analogue Inputs . . . . .	6-14
Group 14 Relay Outputs . . . . .	6-18
Group 15 Analogue Outputs . . . . .	6-24
Group 16 System Ctr Inputs . . . . .	6-28
Group 20 Limits . . . . .	6-31
Group 21 Start/Stop . . . . .	6-34
Group 22 Accel/Decel . . . . .	6-38
Group 23 Speed Ctrl . . . . .	6-41



Group 24 Torque Ctrl. . . . .	6-46
Group 25 Critical Speeds . . . . .	6-47
Group 26 Motor Control . . . . .	6-49
Group 30 Fault Functions . . . . .	6-52
Group 31 Automatic Reset . . . . .	6-62
Group 32 Supervision . . . . .	6-64
Group 33 Information. . . . .	6-66
Group 34 Process Variable . . . . .	6-67
Group 35 Mot Temp Meas . . . . .	6-69
Group 40 PID Control . . . . .	6-75
Group 42 Brake Control. . . . .	6-87
Group 45 Function Selection . . . . .	6-93
Group 50 Encoder Module . . . . .	6-95
Group 51 Communication Module . . . . .	6-97
Group 52 Standard Modbus . . . . .	6-97
Group 60 MASTER/FOLLOWER . . . . .	6-98
Group 70 DDCS Control . . . . .	6-105
Group 90 D SET REC ADDR . . . . .	6-106
Group 92 D SET TR ADDR . . . . .	6-106
Group 96 EXTERNAL AO . . . . .	6-107
Group 98 Option Modules . . . . .	6-109

### **Chapter 7 – Fault Tracing**

Fault Tracing . . . . .	7-1
Fault Resetting . . . . .	7-1
Fault History . . . . .	7-2
Fault and Warning Messages . . . . .	7-2

### **Appendix A – Complete Parameter Settings**

### **Appendix B – Default Settings of Application Macros**

### **Appendix C – Fieldbus Control**

Overview . . . . .	C-1
Control via NDCO Board Channel CH0 . . . . .	C-2
Fieldbus Adapter Communication Set-up . . . . .	C-2
AF 100 Connection . . . . .	C-3
Control through the Standard Modbus Link . . . . .	C-5
Communication Set-up . . . . .	C-5
Drive Control Parameters . . . . .	C-6
The Fieldbus Control Interface . . . . .	C-9
The Control Word and the Status Word . . . . .	C-9
References . . . . .	C-9
How Direction of Rotation Is Determined in Fieldbus Control . . . . .	C-12
Actual Values. . . . .	C-14
Modbus Addressing. . . . .	C-14
Communication Profiles . . . . .	C-17

**Appendix D – Analogue Extension Module NAIO**

Speed Control Through NAIO .....	D-1
Basic Checks .....	D-1
NAIO Settings .....	D-1
ACS 600 Parameter Settings .....	D-1
Bipolar Input in Basic Speed Control .....	D-2
Bipolar Input in Joystick Mode .....	D-3

**Index**

# Chapter 1 – Introduction to This Manual

---

## **Overview**

This chapter describes the purpose, contents and the intended audience of this manual. It also lists related publications.

This Manual is compatible with the ACS 600 Standard Application Program version 6.0 or later.

## **Before You Start**

The purpose of this manual is to provide you with the information necessary to control and program your ACS 600 drive.

The audience for this manual is expected to have:

- Knowledge of standard electrical wiring practices, electronic components, and electrical schematic symbols.
- Minimal knowledge of ABB product names and terminology.
- No experience or training in installing, operating, or servicing the ACS 600.

## **What This Manual Contains**

*Safety Instructions* can be found on pages iii - iv of this manual. The Safety Instructions describe the formats for various warnings and notations used in this manual. This chapter also states the general safety instructions which must be followed.

*Chapter 1 – Introduction*, the chapter you are reading now, introduces you to the *ACS 600 Firmware Manual*.

*Chapter 2 – Overview of ACS 600 Programming and the Control Panel* provides an overview of programming your ACS 600. This chapter describes the operation of the Control Panel used for controlling and programming.

*Chapter 3 – Start-up Data* lists and explains the Start-up Data parameters.

*Chapter 4 – Control Operation* describes actual signals and keypad and external controls.

*Chapter 5 – Standard Application Macro Programs* describes the operation and suitable applications of five standard Application Macros and the User Macro.

*Chapter 6 – Parameters* lists the ACS 600 parameters and explains the functions of each parameter.

*Chapter 7 – Fault Tracing* lists the ACS 600 fault and warning messages, possible causes and remedies.

*Appendix A – Complete Parameter Settings* lists, in tabular form, all parameter settings for the ACS 600.

*Appendix B – Default Settings of Application Macros* lists default settings of ACS 600 Application Macros in tabular form.

*Appendix C – Fieldbus Control* contains the information needed to control the ACS 600 through a fieldbus adapter module. There are several fieldbus adapter modules for the ACS 600 available as optional equipment.

*Appendix D – Analogue Extension Module NAIO* contains the information needed to control the ACS 600 through an Analogue Extension Module NAIO (optional).

*Index* helps you locate the page numbers of topics contained in this manual.

### **Related Publications**

In addition to this manual the ACS 600 user documentation includes the following manuals:

- Start-up Guide for ACS 600 equipped with Standard Application Program (English code: 3BFE 64049224)
- Hardware manuals for various ACS 600 family members
- Several Installation and Start-up Guides for the optional devices for the ACS 600

## Chapter 2 – Overview of ACS 600 Programming and the CDP 312 Control Panel

---

### **Overview**

This chapter describes how to use the panel with ACS 600 to modify parameters, monitor actual values and control the drive.

---

**Note:** The CDP 312 Panel does not communicate with ACS 600 Standard Application Program versions 3.x or earlier. The CDP 311 Panel does not communicate with program version 5.x or later.

---

### **ACS 600 Programming**

The user can change the configuration of the ACS 600 to meet the needs of the application by programming. The ACS 600 is programmable through a set of parameters.

#### **Application Macros**

Parameters can be set one by one or a preprogrammed set of parameters can be selected. Preprogrammed parameter sets are called Application Macros. See *Chapter 5 – Standard Application Macro Programs* for further information on the Application Macros.

#### **Parameter Groups**

In order to simplify programming, parameters in the ACS 600 are organised in Groups. Parameters of the Start-Up Data Group are described in *Chapter 3 – Start-up Data* and other parameters in *Chapter 6 – Parameters*.

#### **Start-up Data Parameters**

The Start-up Data Group contains the basic settings needed to match the ACS 600 with your motor and to set the Control Panel display language. This group also contains a list of preprogrammed Application Macros. The Start-up Data Group includes parameters that are set at start-up, and should not need to be changed later on. See *Chapter 3 – Start-up Data* for description of each parameter.

### **Control Panel**

The Control Panel is the device used for controlling and programming the ACS 600. The Panel can be attached directly to the door of the cabinet or it can be mounted, for example, in a control desk.

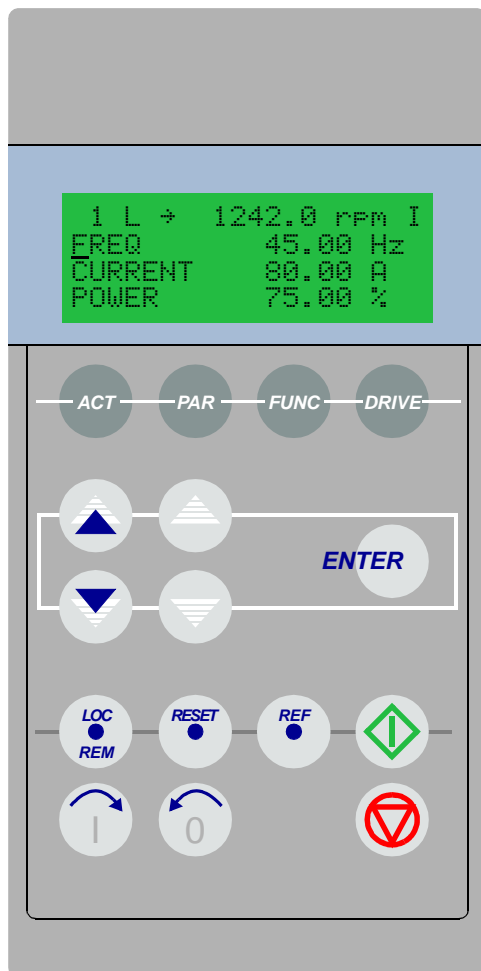

Figure 2-1 The Control Panel.

- Display** The LCD type display has 4 lines of 20 characters.  
The language is selected at start-up by Parameter 99.01 LANGUAGE.
- Keys** The keys on the Control Panel are flat, labelled push-buttons. Their functions are explained on the next page.

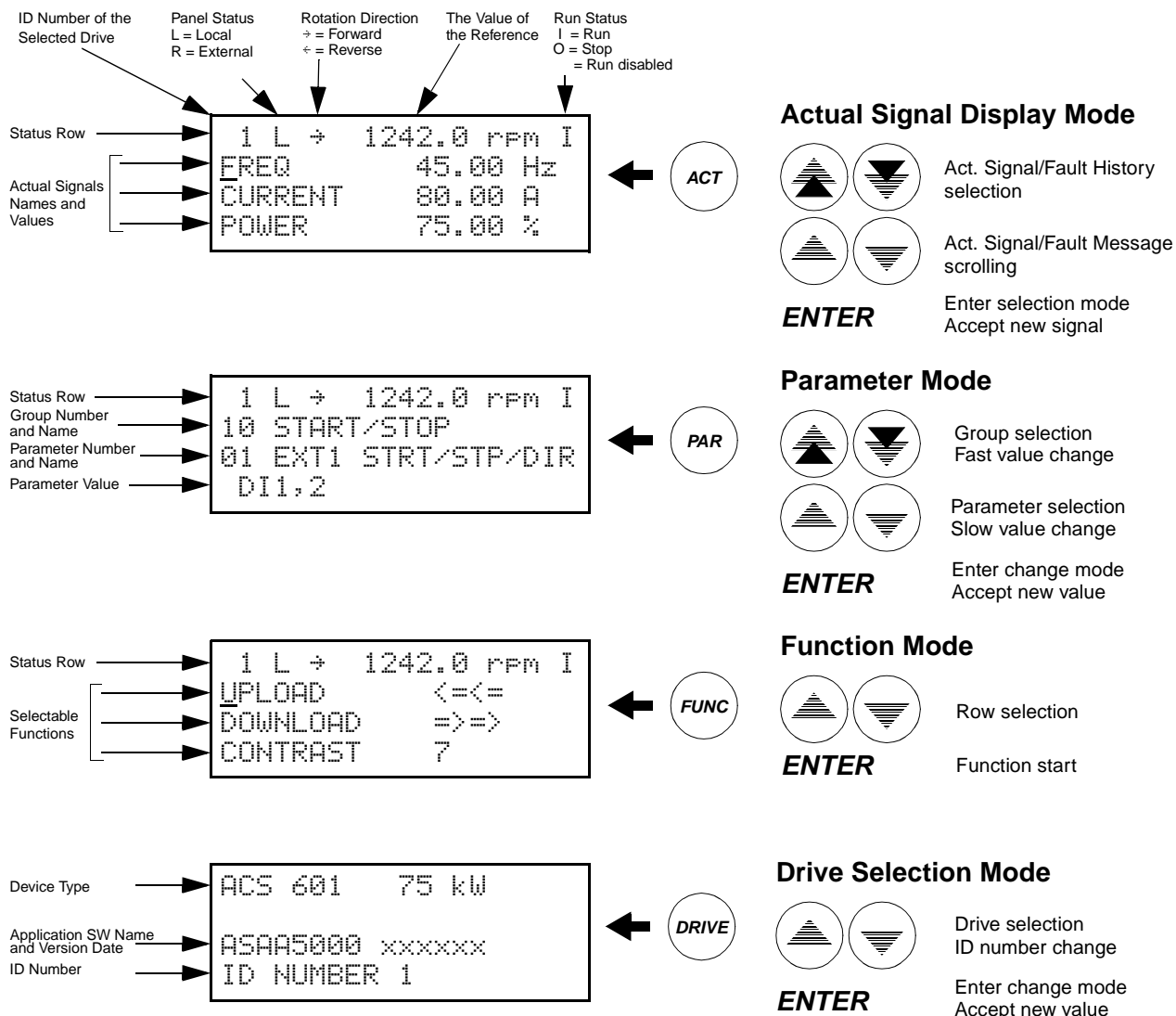

Figure 2-2 Control Panel Display indications and function of the Control Panel keys.

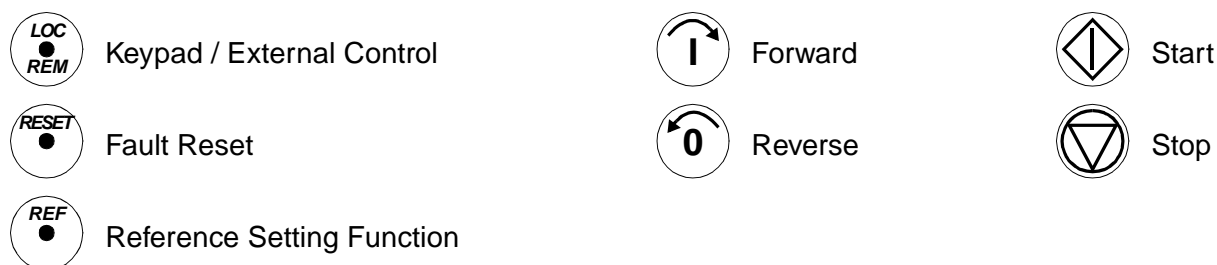

Figure 2-3 Operational commands of the Control Panel keys.

## Panel Operation

The following is a description of the operation of the Control Panel. The Control Panel Keys and Displays are explained in Figure 2-1, Figure 2-2, and Figure 2-3.

### Keypad Modes

The Control Panel has four different keypad modes: Actual Signal Display Mode, Parameter Mode, Function Mode, and Drive Selection Mode. In addition to these, there is a special Identification Display, which is displayed after connecting the panel to the link. The Identification Display and the keypad modes are described briefly below.

### Identification Display

When the panel is connected for the first time, or the power is applied to the drive, the Identification Display appears.

---

**Note:** The panel can be connected to the drive while power is applied to the drive.

---

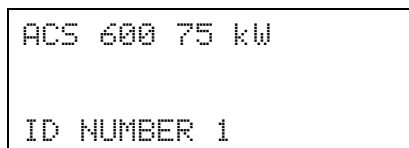

```
ACS 600 75 kW
ID NUMBER 1
```

After two seconds, the display will clear, and the Actual Signals of the drive will appear.

### Actual Signal Display Mode

This mode includes two displays, the Actual Signal Display and the Fault History Display. The Actual Signal Display is displayed first when the Actual Signal Display mode is entered. If the drive is in a fault condition, the Fault Display will be shown first.

The panel will automatically return to the Actual Signal Display Mode from other modes if no keys are pressed within one minute (exceptions: Status Display in Drive Selection Mode and Fault Display Mode).

In the Actual Signal Display Mode you can monitor three Actual Signals at a time. For more information of actual signals see *Chapter 4 – Control Operation*. How to select the three Actual Signals to the display is explained in Table 2-2.

The Fault History includes information on 64 faults and warnings that occurred in your ACS 600. 16 remain in the memory over a power switch-off. The procedure for clearing the Fault History is described in Table 2-3.

The table below shows the events that are stored in the Fault History. For each event it is described what information is included.



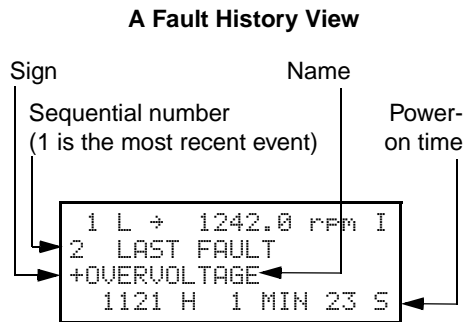

Event	Information
A fault is detected by ACS 600.	Sequential number of the event. Name of the fault and a "+" sign in front of the name. Total power on time.
A fault is reset by user.	Sequential number of the event. -RESET FAULT text. Total power on time.
A warning is activated by ACS 600.	Sequential number of the event. Name of the warning and a "+" sign in front of the name. Total power on time.
A warning is deactivated by ACS 600.	Sequential number of the event. Name of the warning and a "-" sign in front of the name. Total power on time.

When a fault or warning occurs in the drive, the message will be displayed immediately, except in the Drive Selection Mode. Table 2-4 shows how to reset a fault. From the fault display, it is possible to change to other displays without resetting the fault. If no keys are pressed the fault or warning text is displayed as long as the fault exists.

See *Chapter 7 – Fault Tracing* for information on fault tracing.

Table 2-1 How to display the full name of the three Actual Signals.



Step	Function	Press key	Display
1.	To display the full name of the three actual signals.	<b>Hold</b> 	
2.	To return to the Actual Signal Display Mode.	<b>Release</b> 	

Table 2-2 How to select Actual Signals to the display.





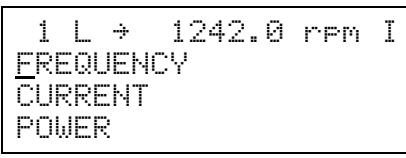

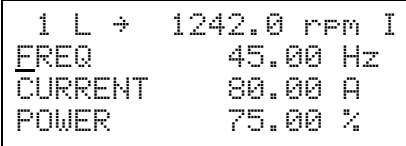



Step	Function	Press key	Display
1.	To enter the Actual Signal Display Mode.		<pre>1 L ÷ 1242.0 rpm I FREQ      45.00 Hz CURRENT   80.00 A POWER     75.00 %</pre>
2.	To select a row (a blinking cursor indicates the selected row).	 	<pre>1 L ÷ 1242.0 rpm I FREQ      45.00 Hz CURRENT   80.00 A POWER     75.00 %</pre>
3.	To enter the Actual Signal Selection Function.	<b>ENTER</b>	<pre>1 L ÷ 1242.0 rpm I 1 ACTUAL SIGNALS 04 CURRENT 80.00 A</pre>
4.	To select an actual signal.  To change the actual signal group.	    	<pre>1 L ÷ 1242.0 rpm I 1 ACTUAL SIGNALS 05 TORQUE 70.00 %</pre>
5.a	To accept the selection and to return to the Actual Signal Display Mode.	<b>ENTER</b>	<pre>1 L ÷ 1242.0 rpm I FREQ      45.00 Hz TORQUE    80.00 A POWER     75.00 %</pre>
5.b	To cancel the selection and keep the original selection, press any of the Mode keys  The selected Keypad Mode is entered.	    	<pre>1 L ÷ 1242.0 rpm I FREQ      45.00 Hz CURRENT   80.00 A POWER     75.00 %</pre>

Table 2-3 How to display a fault and reset the Fault History. The fault history cannot be reset if there is a fault or warning active.











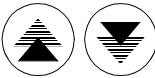
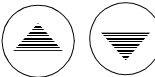

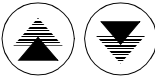





Step	Function	Press key	Display
1.	To enter the Actual Signal Display Mode.		<pre>1 L ÷ 1242.0 rpm I ERED 45.00 Hz CURRENT 80.00 A POWER 75.00 %</pre>
2.	To enter the Fault History Display.		<pre>1 L ÷ 1242.0 rpm I 1 LAST FAULT +OVERCURRENT 6451 H 21 MIN 23 S</pre>
3.	To select the previous (UP) or the next fault/warning (DOWN).		<pre>1 L ÷ 1242.0 rpm I 2 LAST FAULT +OVERVOLTAGE 1121 H 1 MIN 23 S</pre>
	To clear the Fault History.		<pre>1 L ÷ 1242.0 rpm I 2 LAST FAULT</pre>
	The Fault History is empty.		<pre>          H      MIN      S</pre>
4.	To return to the Actual Signal Display Mode.		<pre>1 L ÷ 1242.0 rpm I ERED 45.00 Hz CURRENT 80.00 A POWER 75.00 %</pre>

Table 2-4 How to display and reset an active fault.

Step	Function	Press Key	Display
1.	To display an active fault.		<pre>1 L ÷ 1242.0 rpm ACS 601 75 kW ** FAULT ** ACS 600 TEMP</pre>
2.	To reset the fault.		<pre>1 L ÷ 1242.0 rpm 0 ERED 45.00 Hz CURRENT 80.00 A POWER 75.00 %</pre>

**Parameter Mode** The Parameter Mode is used for changing the ACS 600 parameters. When this mode is entered for the first time after power up, the display will show the first parameter of the first group. The next time the Parameter Mode is entered, the previously selected parameter is shown.

Table 2-5 How to select a parameter and change the value.

Step	Function	Press key	Display
1.	To enter the Parameter Mode.		<pre> 1 L ÷ 1242.0 rpm 0 10 START/STOP/DIR 01 EXT1 STRT/STP/DIR DI1,2                     </pre>
2.	To select a different group.	 	<pre> 1 L ÷ 1242.0 rpm 0 11 REFERENCE SELECT 01 KEYPAD REF SEL REF1 (rpm)                     </pre>
3.	To select a parameter.	 	<pre> 1 L ÷ 1242.0 rpm 0 11 REFERENCE SELECT 03 EXT REF1 SELECT AI1                     </pre>
4.	To enter the Parameter Setting function.	<b>ENTER</b>	<pre> 1 L ÷ 1242.0 rpm 0 11 REFERENCE SELECT 03 EXT REF1 SELECT [AI1]                     </pre>
5.	To change the parameter value. (slow change for numbers and text)  (fast change for numbers only)	   	<pre> 1 L ÷ 1242.0 rpm 0 11 REFERENCE SELECT 03 EXT REF1 SELECT [AI2]                     </pre>
6a.	To save the new value.	<b>ENTER</b>	<pre> 1 L ÷ 1242.0 rpm 0 11 REFERENCE SELECT 03 EXT REF1 SELECT AI2                     </pre>
6b.	To cancel the new setting and keep the original value, press any of the Mode keys. The selected Keypad Mode is entered.	   	<pre> 1 L ÷ 1242.0 rpm 0 11 REFERENCE SELECT 03 EXT REF1 SELECT AI1                     </pre>

**Function Mode**

The Function Mode is used to select special functions. These functions include Parameter Upload, Parameter Download and setting the contrast of the Control Panel display.

Parameter Upload will copy all parameters and the results of motor identification from the drive to the panel. The upload function can be performed while the drive is running. Only the STOP command can be given during the uploading process.

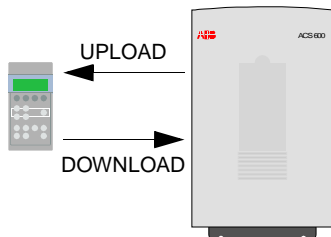

Table 2-6 and subsection *Copying Parameters from One Unit to Other Units* below describe how to select and perform Parameter Upload and Parameter Download functions.









**Note:**

- By default, Parameter Download will copy parameter Groups 10 to 97 stored in the panel to the drive. Groups 98 and 99 concerning options, language, macro and motor data are not downloaded.
- Uploading has to be done before downloading.
- The parameters can be uploaded and downloaded only if the drive firmware versions (see Parameters 33.01 SOFTWARE VERSION and 33.02 APPL SW VERSION) of the destination drive are the same as the versions of the source drive.
- The drive must be stopped during the downloading process.

Table 2-6 How to select and perform a function.



Step	Function	Press Key	Display
1.	To enter the Function Mode.		<pre> 1 L → 1242.0 rpm 0 UPLOAD   &lt;=&lt;= DOWNLOAD =&gt;=&gt; CONTRAST 4                     </pre>
2.	To select a function (a flashing cursor indicates the selected function).		<pre> 1 L → 1242.0 rpm 0 UPLOAD   &lt;=&lt;= <u>DOWNL</u>AD =&gt;=&gt; CONTRAST 4                     </pre>
3.	To start the selected function.	<b>ENTER</b>	<pre> 1 L → 1242.0 rpm 0 =&gt;=&gt;=&gt;=&gt;=&gt;=&gt;=&gt; DOWNLAD                     </pre>

Table 2-7 How to set the contrast of the panel display.

Step	Function	Press Key	Display
1.	To enter the Function Mode.		<pre> 1 L ÷ 1242.0 rpm 0 <u>U</u>PLOAD    &lt;=&lt;= D<small>OWN</small>LOAD  =&gt;=&gt; C<small>ON</small>TRAST  4                     </pre>
2.	To select a function (a flashing cursor indicates the selected function).	 	<pre> 1 L ÷ 1242.0 rpm 0 <u>U</u>PLOAD    &lt;=&lt;= D<small>OWN</small>LOAD  =&gt;=&gt; <u>C</u>ONTRAST  4                     </pre>
3.	To enter the contrast setting function.	<b>ENTER</b>	<pre> 1 L ÷ 1242.0 rpm 0 C<small>ON</small>TRAST  [4]                     </pre>
4.	To adjust the contrast.	 	<pre> 1 L ÷ 1242.0 rpm 0 C<small>ON</small>TRAST  [6]                     </pre>
5.a	To accept the selected value.	<b>ENTER</b>	<pre> 1 L ÷ 1242.0 rpm 0 U<small>P</small>LOAD    &lt;=&lt;= D<small>OWN</small>LOAD  =&gt;=&gt; <u>C</u>ONTRAST  6                     </pre>
5.b	To cancel the new setting and retain the original value, press any of the Mode keys.  The selected Keypad Mode is entered.	   	<pre> 1 L ÷ 1242.0 rpm 0 U<small>P</small>LOAD    &lt;=&lt;= D<small>OWN</small>LOAD  =&gt;=&gt; <u>C</u>ONTRAST  4                     </pre>

*Copying Parameters from One Unit to Other Units*

You can copy parameters from one drive to another by using the Parameter Upload and Parameter Download functions in the Function Mode. Follow the procedure below:

1. Select the correct options (Group 98), language and macro (Group 99) for each drive.
2. Set the rating plate values for the motors (Group 99), and perform the identification for each motor (the Identification Magnetisation at zero speed by pressing start, or an ID Run. For the ID Run procedure see *Chapter 3 – Start-up Data*).
3. Set the parameters in Groups 10 to 97 as preferred in one ACS 600 drive.
4. Upload the parameters from the ACS 600 to the panel (see Table 2-6).
5. Press the  key to change to external control (no L visible on the first row of the display).
6. Disconnect the panel and reconnect it to the next ACS 600 unit.
7. Ensure the target ACS 600 is in Local control (L shown on the first row of the display). If necessary, change by pressing .
8. Download the parameters from the panel to the ACS 600 unit (see Table 2-6).
9. Repeat steps 7. and 8. for the rest of the units.

---

**Note:** Parameters in Groups 98 and 99 concerning options, language, macro and motor data are not downloaded.<sup>1)</sup>

---

<sup>1)</sup> The restriction prevents downloading of incorrect motor data (Group 99). In special cases it is also possible to download Groups 98 and 99 and the results of the motor identification. For more information, please contact your local ABB representative.

**Drive Selection Mode** In normal use the features available in the Drive Selection Mode are not needed; these features are reserved for applications where several drives are connected to one Panel Link. (For more information, see the *Installation and Start-up Guide for the Panel Bus Connection Interface Module, NBCI*, Code: 3AFY 58919748).





Panel Link is the communication link connecting the Control Panel and the ACS 600. Each on-line station must have an individual identification number (ID). By default, the ID number of the ACS 600 is 1.

---

**CAUTION!** The default ID number setting of the ACS 600 should not be changed unless it is to be connected to the Panel Link with other drives on-line.

---

Table 2-8 How to select a drive and change its ID number.

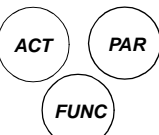
Step	Function	Press key	Display
1.	To enter the Drive Selection Mode.		<div style="border: 1px solid black; padding: 5px; width: fit-content;"> <pre>ACS 600    75 kW ASAAA5000  xxxxxxxx ID NUMBER  1</pre> </div>
2.	<p>To select the next drive/view.</p> <p>The ID number of the station is changed by first pressing <b>ENTER</b> (the brackets round the ID number appear) and then adjusting the value with  buttons. The new value is accepted with <b>ENTER</b>.</p> <p>The power of the ACS 600 must be switched off to validate its new ID number setting (the new value is not displayed until the power is switched off and on).</p> <p>The Status Display of all devices connected to the Panel Link is shown after the last individual station. If all stations do not fit on the display at once, press  to view the rest of them.</p>		<div style="border: 1px solid black; padding: 5px; width: fit-content;"> <pre>ACS 600    75 kW ASAA5000  xxxxxxxx ID NUMBER  1</pre> </div> <div style="border: 1px solid black; padding: 5px; width: fit-content; margin-top: 10px;"> <pre>1<sup>‡</sup></pre> </div> <p>Status Display Symbols:  <sup>‡</sup> = Drive stopped, direction forward  <sup>†</sup> = Drive running, direction reverse  F = Drive has tripped on a fault</p>
3.	<p>To connect to the last displayed drive and to enter another mode, press one of the Mode keys.</p> <p>The selected Keypad Mode is entered.</p>		<div style="border: 1px solid black; padding: 5px; width: fit-content;"> <pre>1 L † 1242.0 rpm I FREQ      45.00 Hz CURRENT   80.00 A POWER     75.00 %</pre> </div>



**Operational Commands**

Operational commands control the operation of the ACS 600. They include starting and stopping the drive, changing the direction of rotation and adjusting the reference. The reference value is used for controlling motor speed or torque.

*Changing Control Location*

Operational commands can be given from the Control Panel always when the status row is displayed and the control location is the panel. This is indicated by L (Local Control) on the display. R (Remote Control) indicates that External control is active and the Panel is the signal source for the external reference or the Start/Stop/Direction signals the ACS 600 is following.

1 L → 1242.0 RPM I	1 R → 1242.0 RPM I
Local Control	External Control by Panel

If there is neither an L nor an R on the first row of the display, the drive is controlled by another device. Operational commands cannot be given from this panel. Only monitoring actual signals, setting parameters, uploading and changing ID numbers is possible.

1 → 1242.0 RPM I
External Control through the I/O interface or communication module

The control is changed between Local and External control locations by pressing the **LOC REM** key. See *Chapter 4 – Control Operation* for the explanation of Local and External control.

*Start, Stop, Direction and Reference*







Start, Stop and Direction commands are given from the panel by pressing , ,  or . Table 2-9 explains how to set the Reference from the panel.

Table 2-9 How to set the reference.

Step	Function	Press Key	Display
1.	To enter a Keypad Mode displaying the status row, press a Mode key.		<pre> 1 L → 1242.0 rpm I FREQ   45.00 Hz CURRENT 80.00 A POWER  75.00 %                     </pre>
2.	To enter the Reference Setting function. A blinking cursor indicates that the Reference Setting function has been selected.		<pre> 1 L →[ 1242.0 rpm]I FREQ   45.00 Hz CURRENT 80.00 A POWER  75.00 %                     </pre>
3.	To change the reference. (slow change)  (fast change)		<pre> 1 L →[ 1325.0 rpm]I FREQ   48.00 Hz CURRENT 85.00 A POWER  80.00 %                     </pre>
4.a	To save the reference, press Enter. The value is stored in the permanent memory; it is restored automatically after power switch-off.	<p><b>ENTER</b></p>	<pre> 1 L → 1325.0 rpm I FREQ   48.00 Hz CURRENT 85.00 A POWER  80.00 %                     </pre>
4.b	To escape the Reference Setting Mode without saving, press any of the Mode keys.  The selected Keypad Mode is entered.		<pre> 1 L → 1325.0 rpm I FREQ   48.00 Hz CURRENT 85.00 A POWER  80.00 %                     </pre>

**Reading and Entering Packed Boolean Values on the CDP 312**

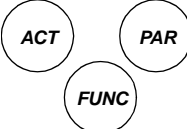
Some actual values and parameters are Packed Boolean, i.e. each individual bit has a defined meaning (explained at the corresponding signal or parameter). On the CDP 312 Control Panel, Packed Boolean values are read and entered in hexadecimal format.

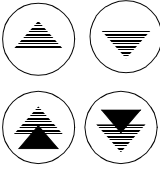
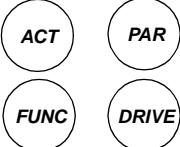
In this example, Bits 1, 3 and 4 of the Packed Boolean value are ON:

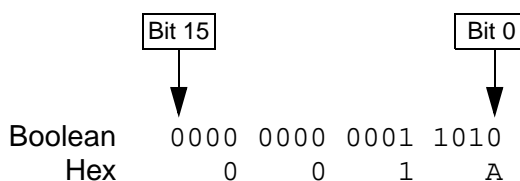

## Chapter 3 – Start-up Data

### Overview

This chapter lists and explains the Start-up Data Parameters. The Start-up Data Parameters are a special set of parameters that allow you to set up the ACS 600 and motor information. Start-up Data Parameters should only need to be set during start-up and should not need to be changed afterwards.

### Start-up Data Parameters

When changing the value of the Start-up Data Parameters, follow the procedure described in *Chapter 2 – Overview of ACS 600 Programming...*, Table 2-5. Table 3-1, lists the Start-up Data Parameters. The Range/Unit column in Table 3-1 shows the parameter values, which are explained in detail below the table.



**WARNING!** Running the motor and the driven equipment with incorrect start-up data can result in improper operation, reduction in control accuracy and damage to equipment.

Table 3-1 Group 99, Start-up Data Parameters.

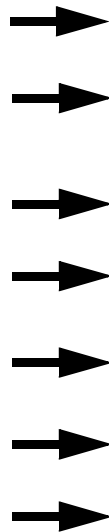

Parameter	Range/Unit	Description
01 LANGUAGE	Languages	Display language selection.
02 APPLICATION MACRO	Application Macros	Application Macro selection.
03 APPLIC RESTORE	NO; YES	Restores parameters to factory setting values.
04 MOTOR CTRL MODE	DTC; SCALAR	Motor control mode selection.
05 MOTOR NOM VOLTAGE	$1/2 \cdot U_N$ of ACS 600 ... $2 \cdot U_N$ of ACS 600	Nominal voltage from the motor rating plate.
06 MOTOR NOM CURRENT	$1/6 \cdot I_{2hd}$ of ACS 600 ... $2 \cdot I_{2hd}$ of ACS 600	Matches the ACS 600 to the rated motor current.
07 MOTOR NOM FREQ	8 ... 300 Hz	Nominal frequency from the motor rating plate.
08 MOTOR NOM SPEED	1 ... 18000 rpm	Nominal speed from the motor rating plate.
09 MOTOR NOM POWER	0 ... 9000 kW	Nominal power from the motor rating plate.
10 MOTOR ID RUN	NO; STANDARD; REDUCED	Selects the type of the motor identification run.

**Parameters 99.04 ... 99.09 are always to be set at start-up.**

If several motors are connected to the ACS 600, some additional instructions must be considered when setting the Start-up Data Parameters. Please contact your local ABB representative for more information.

**99.01 LANGUAGE** The ACS 600 displays all information in the language you select. The alternatives are:

- English, English (Am), French, Spanish, Portuguese, German, Italian, Dutch, Danish, Swedish, Finnish, Czech, Polish

If English (Am) is selected, the unit of power used is HP instead of kW.

**99.02 APPLICATION MACRO** This parameter is used to select the Application Macro which will configure the ACS 600 for a particular application. Refer to *Chapter 5 – Standard Application Macro Programs* for a list and description of available Application Macros. There is also a selection for saving the current settings as a User Macro (USER 1 SAVE or USER 2 SAVE), and recalling these settings (USER 1 LOAD or USER 2 LOAD).

There are parameters that are not included in Macros. See section 99.03 APPLIC RESTORE.

---

**Note:** User Macro load restores also the motor settings of the Start-up Data group and the results of the Motor Identification. Check that the settings correspond to the motor used.

---

**99.03 APPLIC RESTORE** Selection YES restores the original settings of an application macro as follows:

- If a standard macro (Factory, ... , Sequential Control) is in use, the parameter values are restored to the default settings (factory settings). Exception: Parameter settings in Group 99 remain unchanged. Results of the motor identification remain unchanged.
- If User Macro 1 or 2 is in use, the parameter values are restored to the last saved values. In addition, the last saved results of the motor identification are restored (see *Chapter 5 – Standard Application Macro Programs*). Exceptions: Settings of Parameters 16.05 USER MACRO IO CHG and 99.02 APPLICATION MACRO remain unchanged.

---

**Note:** The parameter settings and the results of motor identification are restored according to the same principles when a macro is changed to another.

---

**99.04 MOTOR CTRL  
MODE**

This parameter sets the motor control mode.

**DTC**

The DTC (Direct Torque Control) mode is suitable for most applications. The ACS 600 performs precise speed and torque control of standard squirrel cage motors without pulse encoder feedback.

If several motors are connected to the ACS 600, there are certain restrictions on the usage of DTC. Please contact your local ABB representative for more information.

**SCALAR**

The scalar control should be selected in those special cases in which the DTC cannot be applied. The SCALAR control mode is recommended for multimotor drives when number of motors connected to the ACS 600 is variable. The SCALAR control is also recommended when the nominal current of the motor is less than 1/6 of the nominal current of the inverter or the inverter is used for test purposes with no motor connected.

The outstanding motor control accuracy of DTC cannot be achieved in the scalar control mode. The differences between the SCALAR and DTC control modes are discussed further in this manual in relevant parameter lists.

There are some standard features that are disabled in the SCALAR control mode: Motor Identification Run (Group 99), Speed Limits (Group 20), Torque Limit (Group 20), DC Hold (Group 21), DC Magnetizing (Group 21), Speed Controller Tuning (Group 23), Torque Control (Group 24), Flux Optimization (Group 26), Flux Braking (Group 26), Underload Function (Group 30), Motor Phase Loss Protection (Group 30), Motor Stall Protection (Group 30).

**99.05 MOTOR NOM  
VOLTAGE**

This parameter matches the ACS 600 with the nominal voltage of the motor as indicated on the motor rating plate.

---

**Note:** It is not allowed to connect a motor with nominal voltage less than  $1/2 \cdot U_N$  or more than  $2 \cdot U_N$  of the ACS 600.

---

**99.06 MOTOR NOM  
CURRENT**

This parameter matches the ACS 600 to the rated motor current. The allowed range  $1/6 \cdot I_{2hd} \dots 2 \cdot I_{2hd}$  of ACS 600 is valid for DTC motor control mode. In SCALAR mode the allowed range is  $0 \cdot I_{2hd} \dots 2 \cdot I_{2hd}$  of ACS 600.

Correct motor run requires that the magnetizing current of the motor does not exceed 90 per cent of the nominal current of the inverter.

**99.07 MOTOR NOM  
FREQUENCY**

This parameter matches the ACS 600 to the rated motor frequency, adjustable from 8 Hz to 300 Hz.

99.08 MOTOR NOM  
SPEED

This parameter matches the ACS 600 to the nominal speed as indicated on the motor rating plate.

---

**Note:** It is very important to set this parameter exactly to the value given on the motor rating plate to guarantee proper operation of the drive. The motor synchronous speed or another approximate value must not be given instead!

---



---

**Note:** The speed limits in *Group 20 Limits* are linked to the setting of 99.08 MOTOR NOM SPEED. If value of Parameter 99.08 MOTOR NOM SPEED is changed, the speed limit settings change automatically as well.

---

99.09 MOTOR NOM  
POWER

This parameter matches the ACS 600 to the rated power of the motor, adjustable between 0 kW and 9000 kW.

99.10 MOTOR ID RUN

This parameter is used to initiate the Motor Identification Run. During the run, the ACS 600 will identify the characteristics of the motor for optimum motor control. The ID Run takes about one minute.

The ID run cannot be performed if the scalar control mode is selected (Parameter 99.04 MOTOR CTRL MODE is set to SCALAR).

**NO**

The Motor ID Run is not performed. This can be selected in most applications. The motor model is calculated at first start by magnetising the motor for 20 to 60 s at zero speed.

**Note:** The ID Run (Standard or Reduced) should be selected if:

- operation point is near zero speed
- operation at torque range above the motor nominal torque within wide speed range and without any pulse encoder (i.e. without any measured speed feedback) is required.

**STANDARD**

Performing the Standard Motor ID Run guarantees that the best possible control accuracy is achieved. The motor must be de-coupled from the driven equipment before performing the Standard Motor ID Run.

**REDUCED**

The Reduced Motor ID Run should be selected instead of the Standard ID Run:

- if mechanical losses are higher than 20 % (i.e. the motor cannot be de-coupled from the driven equipment)
- if flux reduction is not allowed while the motor is running (i.e. in case of a braking motor in which the brake switches on if the flux is reduced below a certain level).

---

**Note:** Check the rotation direction of the motor before starting the Motor ID Run. During the run the motor will rotate in the forward direction.

---



**WARNING!** The motor will run at up to approximately 50 % ... 80 % of the nominal speed during the Motor ID Run. BE SURE THAT IT IS SAFE TO RUN THE MOTOR BEFORE PERFORMING THE MOTOR ID RUN!

---

### **ID Run Procedure**

To perform the Motor ID Run:

---

**Note:** If parameter values (Group 10 to 98) are changed before the ID Run, check that the new settings meet the following conditions:

- 20.01 MINIMUM SPEED  $\leq 0$ .
  - 20.02 MAXIMUM SPEED  $> 80\%$  of motor rated speed.
  - 20.03 MAXIMUM CURRENT  $\geq 100 \cdot I_{hd}$ .
  - 20.04 MAXIMUM TORQUE  $> 50\%$ .
- 

1. Ensure that the Panel is in the local control mode (L displayed on the status row). Press the  key to switch modes.
2. Change the selection to STANDARD or REDUCED:

```

1 L ->1242.0 rpm      0
99 START-UP DATA
10 MOTOR ID RUN
[STANDARD]

```

3. Press **ENTER** to verify selection. The following message will be displayed:

```



1 L ->1242.0 rpm      0
ACS 600 55 kW
**WARNING**
ID RUN SEL

```

4. To start the ID Run, press the  key. The run enable signal must be active (see Parameter 16.01 RUN ENABLE).

Warning when the ID Run is started	Warning during the ID Run	Warning after a successfully completed ID Run
<pre> 1 L -&gt; 1242.0 rpm    I ACS 600 55 kW **WARNING** MOTOR STARTS                     </pre>	<pre> 1 L -&gt; 1242.0 rpm    I ACS 600 55 kW **WARNING** ID RUN                     </pre>	<pre> 1 L -&gt; 1242.0 rpm    I ACS 600 55 kW **WARNING** ID DONE                     </pre>

In general it is recommended not to press any control panel keys during the ID run. However:

- The Motor ID Run can be stopped at any time by pressing the Control Panel  key or removing the Run enable signal.
- After the ID Run is started with the  key, it is possible to monitor the actual values by first pressing the **ACT** key and then the  key.



## Chapter 4 – Control Operation

### Overview

This chapter describes the Actual Signals, the Fault History, and the Local and External control modes.

### Actual Signals

Actual Signals monitor ACS 600 functions. They do not affect the performance of the ACS 600. Actual Signal values are measured or calculated by the drive and they cannot be set by the user.

To select the actual values to be displayed follow the procedure described in *Chapter 2 – Overview...*, Table 2-2.

### Group 1 Actual Signals

Table 4-1 Group 1 Actual Signals. The signals marked with \* are updated only when the PID Control Macro is selected.

Actual Signal	Short Name	Range/Unit	Description
01 PROCESS VARIABLE	PROC VAR	0 ... 100000/user units	Process variable based on settings in Parameter Group 34.
02 SPEED	SPEED	rpm	Calculated speed, in motor rpm. Filter time setting by 34.04 MOTOR SP FILTER TIM.
03 FREQUENCY	FREQ	Hz	Calculated motor frequency.
04 CURRENT	CURRENT	A	Measured motor current.
05 TORQUE	TORQUE	%	Calculated motor torque. 100 is the motor nominal torque rating. Filter time setting by 34.05 TORQ ACT FILT TIM.
06 POWER	POWER	%	Motor power. 100 is the nominal power rating.
07 DC BUS VOLTAGE V	DC BUS V	V	Measured Intermediate circuit voltage.
08 MAINS VOLTAGE	MAINS V	V	Calculated supply voltage.
09 OUTPUT VOLTAGE	OUT VOLT	V	Calculated motor voltage.
10 ACS 600 TEMP	ACS TEMP	C	Temperature of the heatsink.
11 EXTERNAL REF 1	EXT REF1	rpm, Hz	External reference 1. The unit is Hz with scalar motor control mode only. See the section <i>Local Control vs. External Control</i> in this chapter
12 EXTERNAL REF 2	EXT REF2	%	External reference 2. See the section <i>Local Control vs. External Control</i> in this chapter.
13 CTRL LOCATION	CTRL LOC	LOCAL; EXT1; EXT2	Active control location. See the section <i>Local Control vs. External Control</i> in this chapter.
14 OP HOUR COUNTER	OP HOURS	h	Elapsed time meter. The timer is running when the NAMC board is powered.
15 KILOWATT HOURS	KW HOURS	kWh	kWh meter.
16 APPL BLOCK OUTPUT	APPL OUT	%	Application block output signal. See Figure 4-3.
17 DI6-1 STATUS	DI6-1		Status of digital inputs. 0 V = "0" +24 VDC = "1"

Actual Signal	Short Name	Range/Unit	Description
18 AI1 (V)	AI1 (V)	V	Value of analogue input 1.
19 AI2 (mA)	AI2 (mA)	mA	Value of analogue input 2.
20 AI3 (mA)	AI3 (mA)	mA	Value of analogue input 3.
21 RO3-1 STATUS	RO3-1		Status of relay outputs. 1 = relay is energised, 0 = relay is de-energised
22 AO1 (mA)	AO1 (mA)	mA	Value of analogue output 1.
23 AO2 (mA)	AO2 (mA)	mA	Value of analogue output 2.
24 ACTUAL VALUE 1 *	ACT VAL1	%	Feedback signal for the PID Controller.
25 ACTUAL VALUE 2 *	ACT VAL2	%	Feedback signal for the PID Controller.
26 CONTROL DEVIATION*	CONT DEV	%	Deviation of the PID Controller (difference between the reference value and the actual value of the PID process controller).
27 APPLICATION MACRO	MACRO	FACTORY; HAND/AUTO; PID-CTRL; T-CTRL; SEQ CTRL; USER 1 LOAD; USER 2 LOAD	Active application macro (value of Parameter 99.02 APPLICATION MACRO)
28 EXT AO1 [mA]	EXT AO1	mA	Value of output 1 of the NAI0 Analogue I/O Extension Module (optional).
29 EXT AO2 [mA]	EXT AO2	mA	Value of output 2 of the NAI0 Analogue I/O Extension Module (optional).
30 PP 1 TEMP	PP 1 TEM	°C	IGBT maximum temperature inside inverter 1 (used only in the high power units with parallel inverters)
31 PP 2 TEMP	PP 2 TEM	°C	IGBT maximum temperature inside inverter 2 (used only in the high power units with parallel inverters)
32 PP 3 TEMP	PP 3 TEM	°C	IGBT maximum temperature inside inverter 3 (used only in the high power units with parallel inverters)
32 PP 4 TEMP	PP 4 TEM	°C	IGBT maximum temperature inside inverter 4 (used only in the high power units with parallel inverters)
34 ACTUAL VALUE	ACT VAL	%	PID controller actual value (see Parameter 40.06 ACTUAL VALUE SEL)
35 MOTOR 1 TEMP	M1 TEMP	°C/ohm	Measured temperature of motor 1. See Parameter 35.01 MOT1 TEMP AI1 SEL.
36 MOTOR 2 TEMP	M2 TEMP	°C/ohm	Measured temperature of motor 2. See Parameter 35.04 MOT2 TEMP AI2 SEL.
37 MOTOR TEMP EST	MOTOR TE	°C	Estimated motor temperature.
38 AI5 mA	AI5 mA	mA	Value of analogue input AI5 read from AI1 of the Analogue I/O Extension Module (NAIO). See <i>Group 98 Option Modules</i> . <sup>1)</sup>
39 AI6 mA	AI6 mA	mA	Value of analogue input AI6 read from AI1 of the Analogue I/O Extension Module (NAIO). See <i>Group 98 Option Modules</i> . <sup>1)</sup>
40 DI7..12 STATUS	DI7..12	0000001 DI7 is on ←	Status of digital inputs DI7 to DI12 read from the Digital I/O Extension Modules (NDIO). See <i>Group 98 Option Modules</i> .
41 EXT RO STATUS	EXT RO	0000001 RO1/NDIO 1 ← is on	Status of external relay outputs on the Digital I/O Extension Module no. 1 (NDIO). 1 = relay is energised, 0 = relay is de-energised

Actual Signal	Short Name	Range/Unit	Description
42 PROCESS SPEED REL	P SPEED	%	Motor actual speed in percent of maximum speed i.e. of Parameter 20.02 MAXIMUM SPEED (or 20.01 MINIMUM SPEED if it has a greater absolute value). If Parameter 99.04 MOTOR CTRL MODE is SCALAR, this value is the relative actual output frequency of ACS 600.
43 MOTOR RUN TIME	MOTOR RUN TIME	h	Motor run time counter. The counter runs when the inverter modulates. Can be reset by 34.06 RESET RUN TIME.

<sup>1)</sup> A voltage signal connected to an analogue input on the NAI0 Analogue I/O Extension Module is also displayed in mA (instead of V).

**Group 2 Actual Signals** By the Group 2 Actual Signals it is possible to monitor the processing of speed and torque references in the drive. For the signal measuring points see Figure 4-3, or the Control Signal Connections figures of the Application Macros (*Chapter 5 – Standard Application Macro Programs*).

Table 4-2 The Table below lists the Group 2 Actual Signals.

Actual Signal	Short Name	Range/Unit	Description
01 SPEED REF 2	S REF 2	rpm	Limited speed reference. 100 % = max. speed. <sup>1)</sup>
02 SPEED REF 3	S REF 3	rpm	Ramped and shaped speed reference. 100 % = max. speed. <sup>1)</sup>
03 ... 08			Reserved
09 TORQ REF 2	T REF 2	%	Speed controller output. 100 % = motor nominal torque.
10 TORQ REF 3	T REF 3	%	Torque reference. 100 % = motor nominal torque.
11 ... 12			Reserved
13 TORQ REF USED	T USED R	%	Torque reference after frequency, voltage and torque limiters. 100 % = motor nominal torque.
14 ... 16			Reserved
17 SPEED ESTIMATED	SPEED ES	rpm	Estimated motor speed.
18 SPEED MEASURED	SPEED ME	rpm	Measured motor actual speed (zero when no encoder is in use).

<sup>1)</sup> Max. speed is the value of Parameter 20.02 MAXIMUM SPEED, or 20.01 MINIMUM SPEED if the absolute value of the minimum limit is greater than the maximum limit.

### Group 3 Actual Signals

Group 3 contains actual signals mainly for fieldbus use (a master station controls the ACS 600 via a serial communication link). All signals in Group 3 are 16 bit data words, each bit corresponding one piece of binary (0,1) information from the drive to the master station.

The signal values (data words) can be viewed also with the Control Panel in hexadecimal format.

For more information on Group 3 Actual Signals, see *Appendix A – Complete Parameter Settings* and *Appendix C – Fieldbus Control*.

### Fault History

The Fault History includes information on the 16 most recent faults and warnings that occurred in the ACS 600 (or 64, if the power is not switched off meanwhile). The description of the fault and the total power-on time are available. The power-on time is calculated always when the NAMC board of the ACS 600 is powered.

*Chapter 2 – Overview...*, Table 2-4, describes how to display and clear the Fault History from the Control Panel.

### Local Control vs. External Control

The ACS 600 can be controlled, i.e. reference, and Start/Stop and Direction commands can be given, from an External control location or from the Local control location.

The selection between Local control and External control can be done with the **LOC REM** key on the Control Panel keypad.

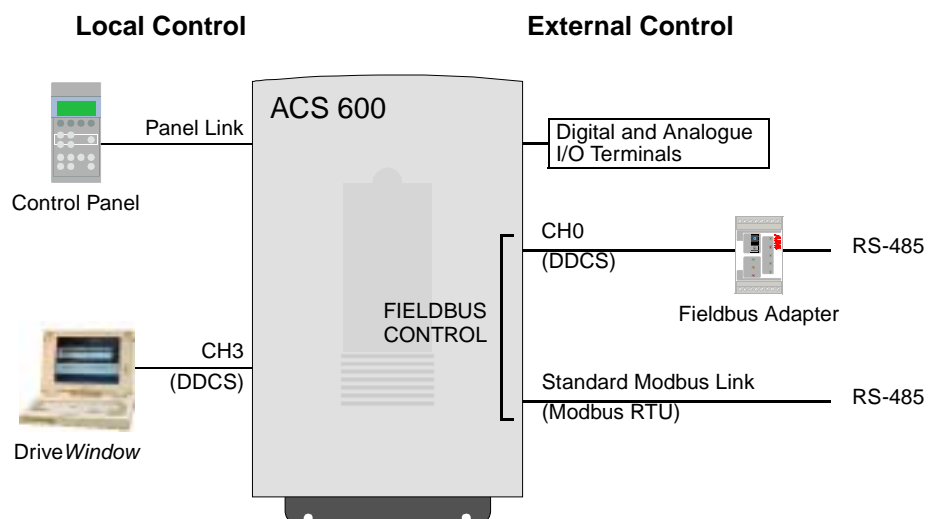
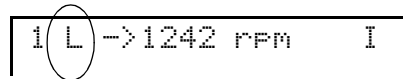

Figure 4-1 Local and external control.

**Local Control** The control commands are given from the Control Panel keypad or from the Drive *Window* PC tool when ACS 600 is in Local control. This is indicated by L on the Control Panel display.



A rectangular display box containing the text "1(L) -> 1242 rpm I". The letter "L" is circled with a thin black line.

**External Control** When the ACS 600 is in External control, the commands are given through the control terminal block on the NIOC board (digital and analogue inputs), optional I/O extension modules and/or either of the two fieldbus interfaces, CH0 Fieldbus Adapter or the Standard Modbus Link. In addition it is also possible to set the Control Panel as the source for the external control.

External control is indicated by a blank character on the Control Panel display or with an R in those special cases when the Panel is defined as a source for the external control.

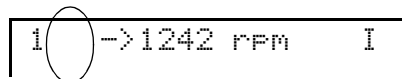

A rectangular display box containing the text "1( ) -> 1242 rpm I". The space between the parentheses is circled with a thin black line.

External Control through the Input/Output terminals, or through the fieldbus interfaces

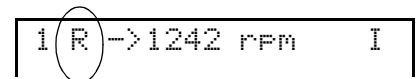

A rectangular display box containing the text "1(R) -> 1242 rpm I". The letter "R" is circled with a thin black line.

External Control by Control Panel (Start/Stop/Direction commands and/or reference given by an "external" Panel)

**Signal Source Selection** In the application program the user can define signal sources for two external control locations EXT1 and EXT2, one of which can be active at a time. Parameter 11.02 EXT1/EXT2 SELECT (O) selects between EXT1 and EXT2.

For EXT1, the source of the Start/Stop/Direction commands is defined by Parameter 10.01 EXT1 STRT/STP/DIR, and the reference source is defined by Parameter 11.03 EXT REF1 SELECT (O). External reference 1 is always a speed reference.

The figure below illustrates the signal source selection for EXT1.

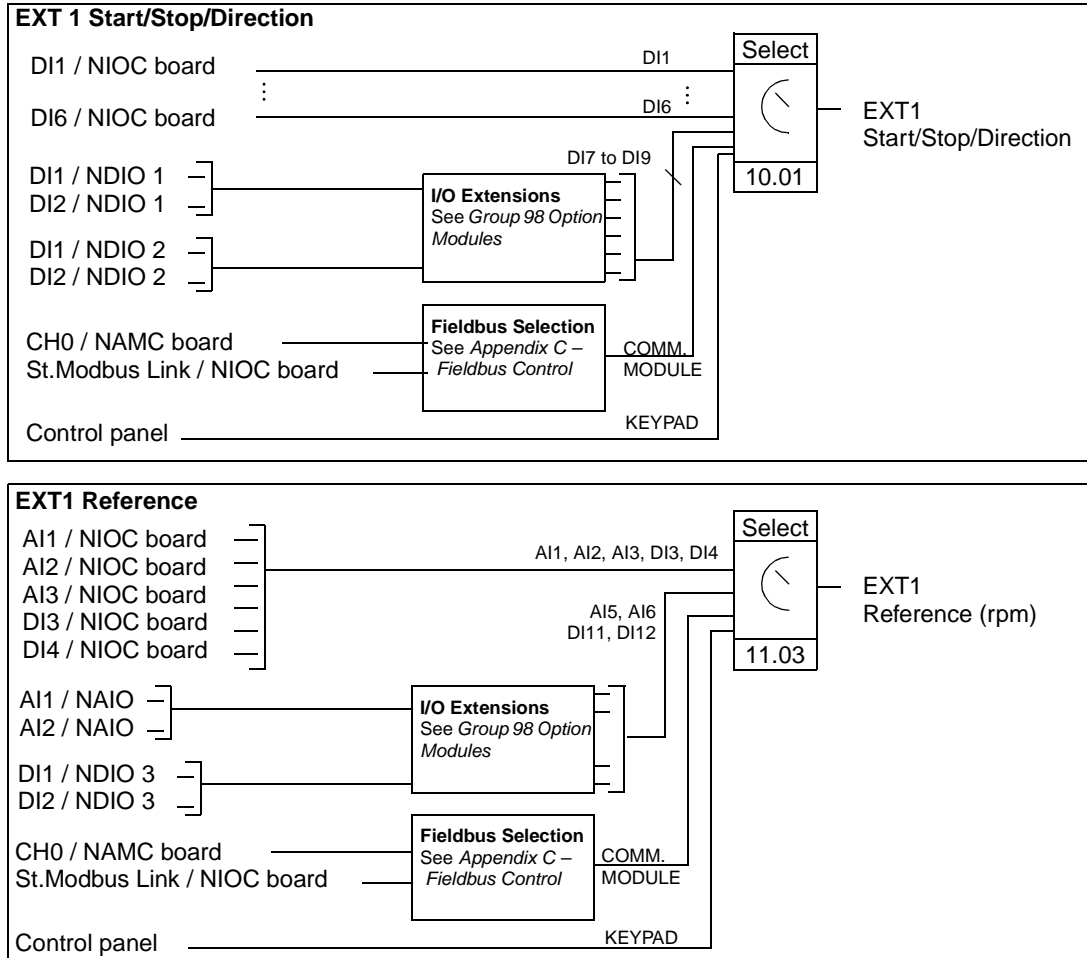

Figure 4-2 Block diagram of the EXT1 signal source selection.

For EXT2, the source of the Start/Stop/Direction commands is defined by Parameter 10.02 EXT2 STRT/STP/DIR, and the reference source is defined by Parameter 11.06 EXT REF2 SELECT (O). External reference 2 can be a speed reference, a torque reference, or a process reference, depending on the Application Macro selected. For the type of external reference 2 refer to the description of the selected Application Macro.

If the ACS 600 is in External control, constant speed operation can also be selected by setting Parameter 12.01 CONST SPEED SEL. One of 15 constant speeds can be selected with digital inputs. **Constant speed selection overrides external speed reference signal unless EXT2 is selected as the active control location in PID Control Macro or Torque Control Macro.**

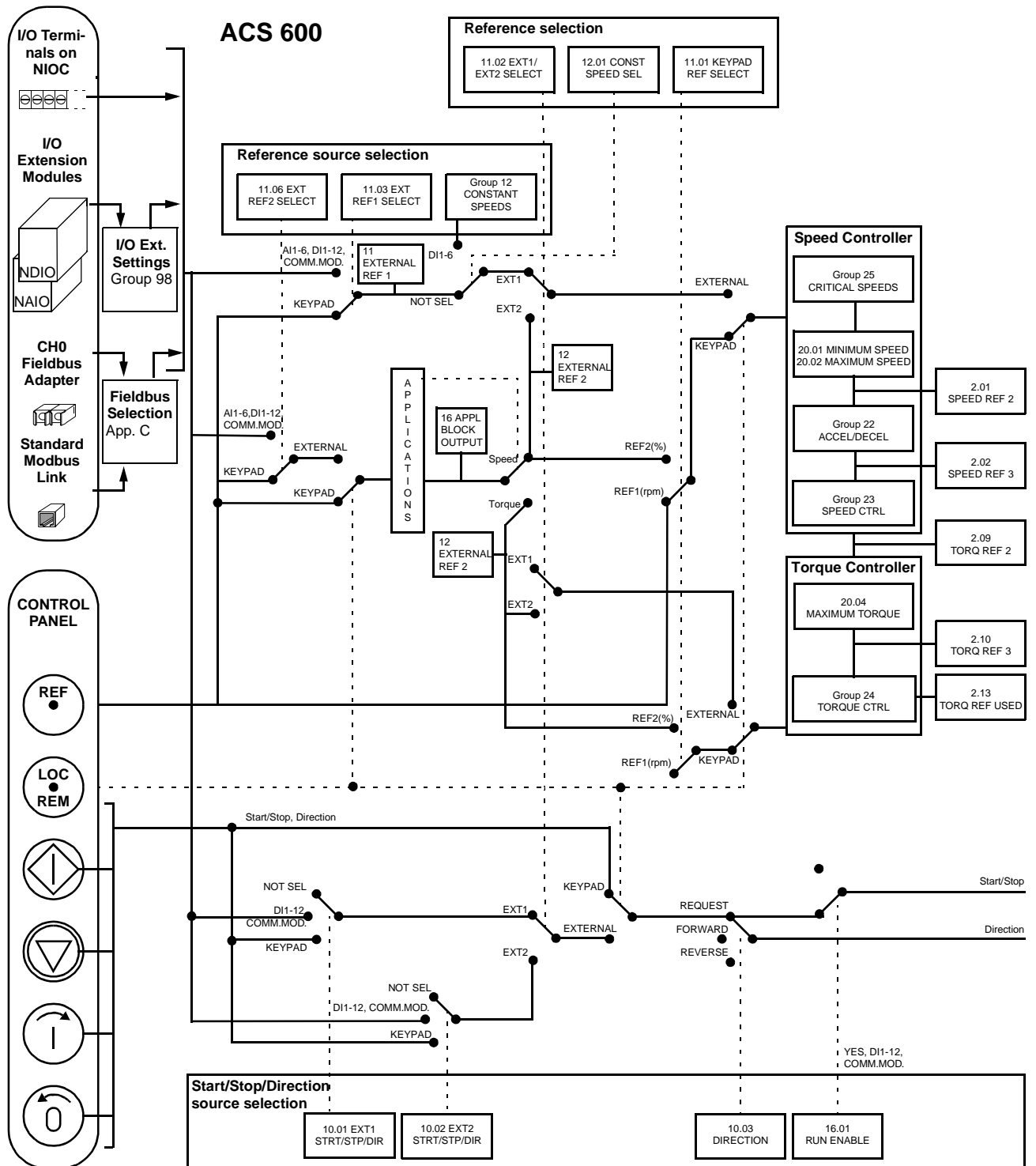

Figure 4-3 Selecting control location and control source.





# Chapter 5 – Standard Application Macro Programs

---

## Overview

This chapter describes the operation of, and suitable applications for, the five standard Application Macros and the two User Macros.

The chapter begins with a general description of Application Macros. Table 5-1, lists the macros along with suitable applications, controls and how to access each macro for parameter modification.

The remainder of this chapter contains the following information for each macro:

- Operation
- Input and Output Signals
- External Connections

The default parameter settings are given in *Appendix B – Default Settings of Application Macros*.

## Application Macros

Application Macros are preprogrammed parameter sets. Using the Application Macros enables a quick and easy start-up of the ACS 600.

Application Macros minimise the number of different parameters to be set during start-up. All parameters have factory-set default values. The Factory Macro is the factory-set default macro.

While starting up the ACS 600, you can select one of the standard macros as the default for your ACS 600 (see Parameter 99.02 APPLICATION MACRO):

- Factory
- Hand/Auto Ctrl
- PID Control
- Sequential Control
- Torque Control

The Application Macro default values are chosen to represent the average values in a typical application. Check that the default settings match your requirements and customise the settings when appropriate. All inputs and outputs are programmable.

---

**Note:** When you change the parameter values of a standard macro, the new settings become active immediately and stay active even if the power of the ACS 600 is switched off and on. However, the default parameter settings (factory settings) of each standard macro are still available. The default settings are restored when Parameter 99.03 APPLIC RESTORE is changed to YES, or if the macro is changed.

---

---

**Note:** There are certain parameters that remain the same even though the macro were changed to another, or the default settings of the macro were restored. For more information, see *Chapter 3 – Start-up Data*, section 99.03 APPLIC RESTORE.

---

## User Macros

In addition to the standard Application Macros, it is possible to create two User Macros. The User Macro allows the user to save the Parameter settings including Group 99, and the results of the motor identification into the permanent memory<sup>1)</sup>, and recall the data at a later time.

To create User Macro 1:

1. Adjust the Parameters. Perform the motor identification if not yet performed.
2. Save the parameter settings and the results of the motor identification by changing Parameter 99.02 APPLICATION MACRO to USER 1 SAVE (press **ENTER**). The storing takes from 20 s to one minute.

To recall the User Macro:

1. Change Parameter 99.02 APPLICATION MACRO to USER 1 LOAD.
2. Press **ENTER** to load.

The User Macro can also be switched via digital inputs (see Parameter 16.05 USER MACRO IO CHG).

---

**Note:** User Macro load restores also the motor settings of the Start-up Data group and the results of the motor identification. Check that the settings correspond to the motor used.

---

**Example:** User Macros make it possible to switch the ACS 600 between two motors without having to adjust the motor parameters and to repeat the motor identification every time the motor is changed. The user can simply adjust the settings and perform the motor identification once for both motors, and then save the data as two User Macros. When the motor is changed, only the corresponding User Macro needs to be loaded and the drive is ready to operate.

<sup>1)</sup> Also the panel reference and the control location setting (Local or Remote) are saved.

## Application Macros Overview

Table 5-1 Application Macros.

Macro	Suitable Applications	Controls	Select
Factory	<p>Conveyors and other industrial constant torque applications.</p> <p>Applications to be run for long periods with constant speed different from the nominal speed of the motor.</p> <p>Vibration endurance test benches needing variable speeds of vibrating motors.</p> <p>Testing of rotating machines.</p> <p>All applications needing traditional external controls.</p>	Keypad, External	FACTORY
Hand/Auto	<p>Processes requiring motor speed control automatically with PLC or other process automation and manually with an external control panel. Active control location selection is made with a digital input.</p> <p>Speed controls having one or two external control locations with reference setting and START/STOP control. Active reference selection is made with digital input.</p>	EXT1, EXT2	HAND/AUTO
PID Control	<p>Intended for use with different closed loop control systems such as pressure control, level control, and flow control. For example:</p> <ul style="list-style-type: none"> <li>• Booster pumps of municipal water supply systems.</li> <li>• Automatic level control of water reservoirs.</li> <li>• Booster pumps of district heating systems.</li> <li>• Speed control of different types of material handling systems where the material flow has to be regulated.</li> </ul>	EXT1, EXT2	PID-CTRL
Torque Control	<p>Processes requiring torque control, e.g. mixers and slave drives. Torque reference comes from a PLC or some other process automation system or control panel. Manual reference is speed reference.</p>	EXT1, EXT2	T-CTRL
Sequential Control	<p>Processes requiring motor speed control in addition to the adjustable speed with 1 to 15 constant speeds and/or with two different acceleration/deceleration times. The control can be performed automatically with a PLC or some other process automation system or by using normal speed selection switches.</p>	Regulated Constant Speed	SEQ CTRL

**Application Macro 1 – Factory**

All drive commands and reference settings can be given from the Control Panel keypad or selectively from an external control location. The active control location is selected with the **LOC REM** key on the Control Panel keypad. The drive is speed controlled.

In External Control the control location is EXT1. The reference signal is connected to analogue input AI1 and Start/Stop and Direction signals to digital inputs DI1 and DI2. By default, the direction is fixed to FORWARD (Parameter 10.03 DIRECTION). DI2 does not control the rotation direction unless Parameter 10.03 DIRECTION is changed to REQUEST.

Three constant speeds are available on digital inputs DI5 and DI6 with external control location selection. Two acceleration/deceleration ramps are preset. The acceleration and deceleration ramps are applied according to the state of digital input DI4.

Two analogue and three relay output signals are available on terminal blocks. Default signals for the Actual Signal Display Mode of the Control Panel are FREQUENCY, CURRENT and POWER.

**Operation Diagram**

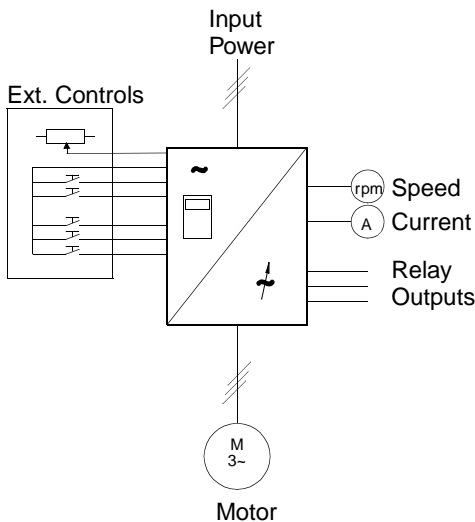

```

1 L ->1242.0 rpm I
FREQ      45.00 Hz
CURRENT   80.00 A
POWER     75.00 %
    
```

Reference and Start/Stop and Direction commands are given from the Control Panel. To change to External, press **LOC REM** key.

```

1 ->1000.0 rpm I
FREQ      40.00 Hz
CURRENT   65.00 A
POWER     60.00 %
    
```

Reference is read from analogue input AI1. Start/Stop and Direction commands are given through digital inputs DI1 and DI2.

Figure 5-1 Operation Diagram for Factory Macro.

**Input and Output Signals**

Table 5-2 Input and Output Signals as set by the Factory Macro.

Input Signals	Output Signals
Start, Stop, Direction (DI1,2) Analogue Reference (AI1) Constant Speed Selection (DI5,6) ACC/DEC 1/2 SEL through (DI4)	Analogue Output AO1: Speed Analogue Output AO2: Current Relay Output RO1: READY Relay Output RO2: RUNNING Relay Output RO3: FAULT (-1)

**External Connections** The following connection example is applicable when the Factory Macro settings are used.

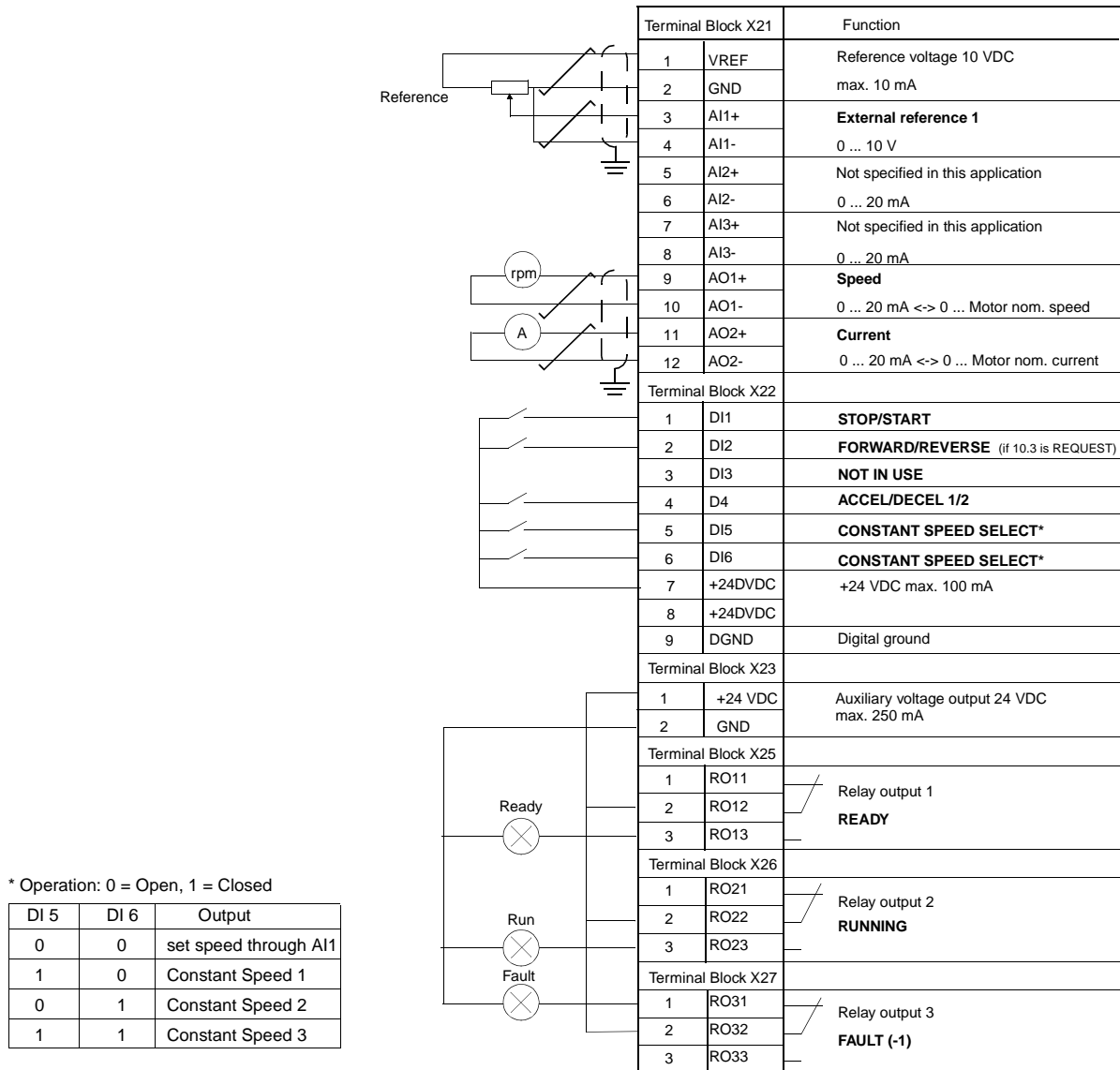

Figure 5-2 Control Connections for Application Macro 1 - Factory. The markings of the NIOC board terminals are given above. In ACS 601 and ACS 604, user connections are always made directly to the input and output terminals of the NIOC board. In ACS 607 the connections are made either directly to NIOC board, or the I/O terminals of the NIOC board are wired to a separate terminal block intended for the user connections. The separate terminal block is optional. See the appropriate hardware manual for the corresponding terminal markings.

**Control Signal Connections** Control signals i.e. Reference, Start, Stop and Direction command connections are established as in Figure 5-3 when you select the Factory Macro.

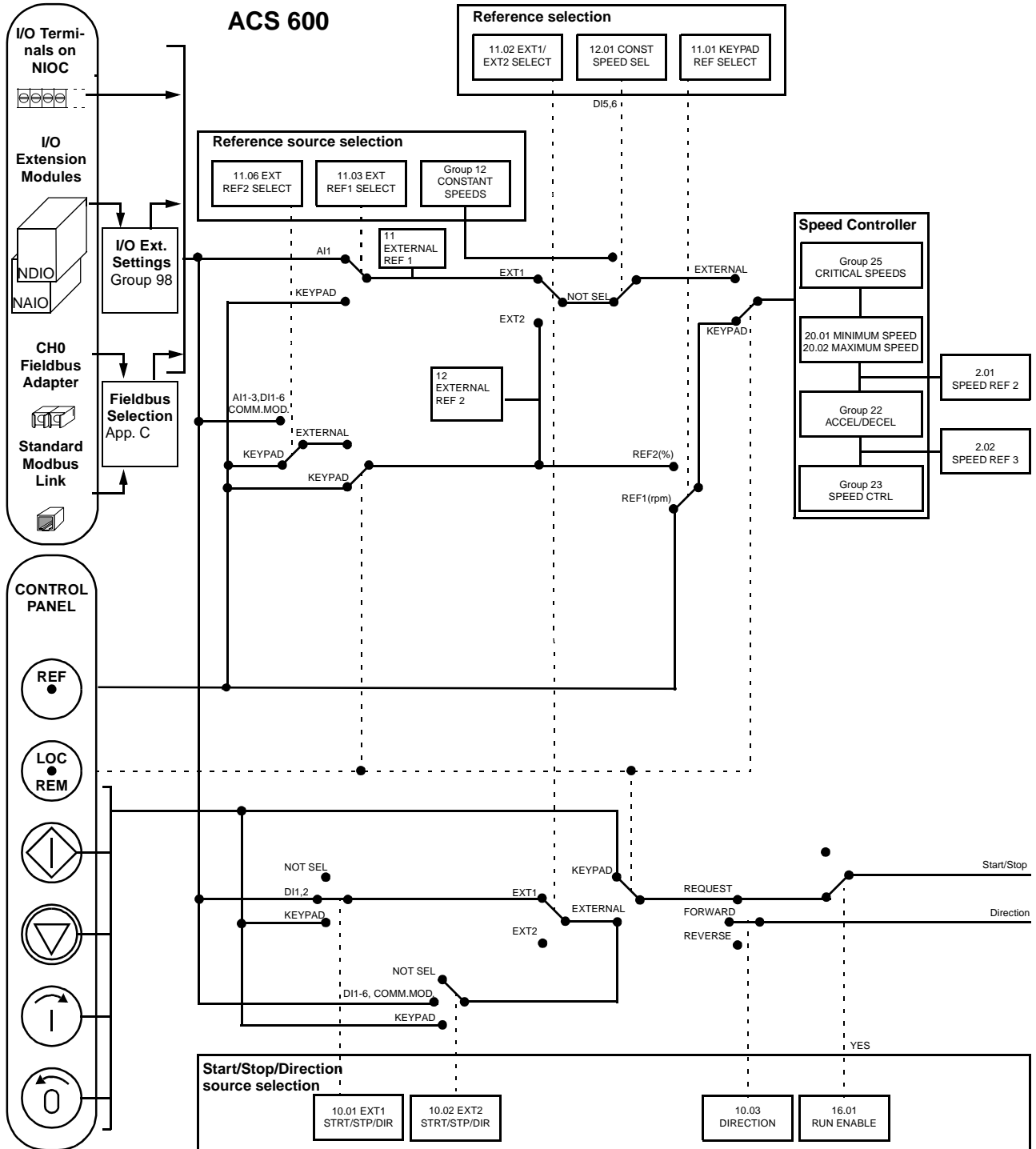

Figure 5-3 Control Signal connections for the Factory Macro.

**Application Macro 2 – Hand/Auto**

Start/Stop and Direction commands and reference settings can be given from one of two external control locations, EXT1 (Hand) or EXT2 (Auto). The Start/Stop/Direction commands of the EXT1 (Hand) are connected to digital inputs DI1 and DI2, and the reference signal is connected to analogue input AI1. The Start/Stop/Direction commands of the EXT2 (Auto) are connected to digital inputs DI5 and DI6, and the reference signal is connected to analogue input AI2. The selection between EXT1 and EXT2 is dependent on the status of digital input DI3. The drive is speed controlled. Speed reference and Start/Stop and Direction commands can be given from the Control Panel keypad also. One constant speed can be selected through digital input DI4.

Speed reference in Auto Control (EXT2) is given as a percentage of the maximum speed of the drive (see Parameters 11.07 EXT REF2 MINIMUM and 11.08 EXT REF2 MAXIMUM).

Two analogue and three relay output signals are available on terminal blocks. Default signals for the Actual Signal Display Mode of the Control Panel are FREQUENCY, CURRENT and CTRL LOC.

**Operation Diagram**

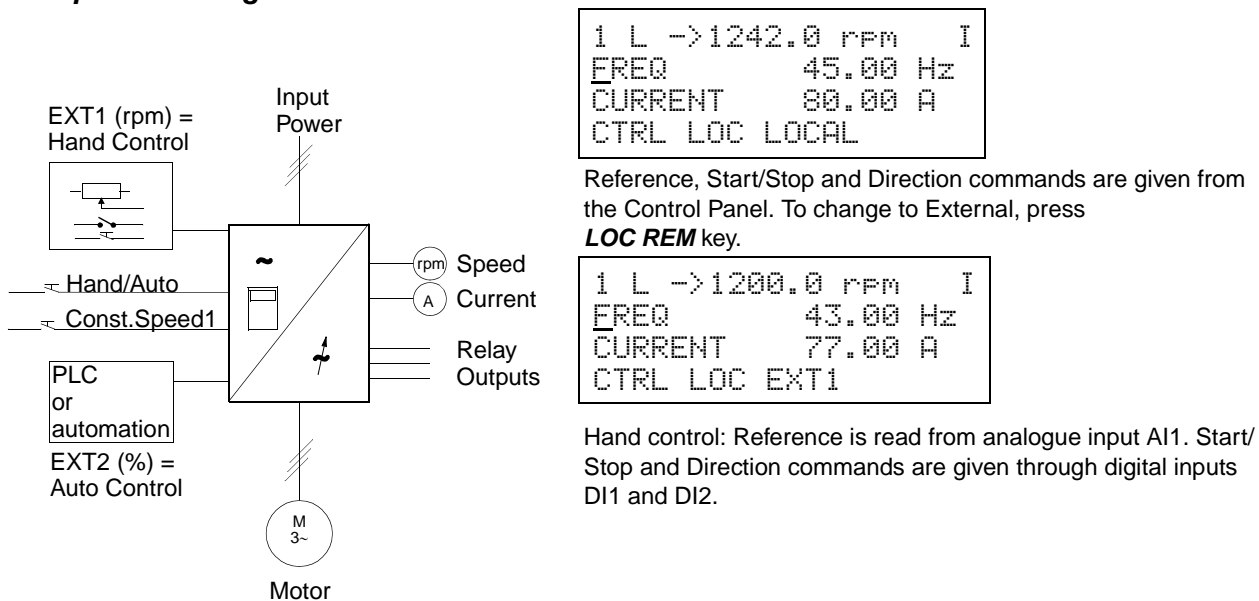

Figure 5-4 Operation Diagram for Hand/Auto Macro.

**Input and Output Signals**

Table 5-3 Input and Output Signals as set by the Hand/Auto Macro.

Input Signals	Output Signals
Start/Stop (DI1,6) and Reverse (DI2,5) Switch for each control location	Speed (AO1)
Two analogue reference inputs (AI1,AI2)	Current (AO2)
Control Location Selection (DI3)	READY (RO1)
Constant Speed Selection (DI4)	RUNNING (RO2)
	FAULT (-1) (RO3)

**External Connections** The following connection example is applicable when the Hand/Auto Macro settings are used.

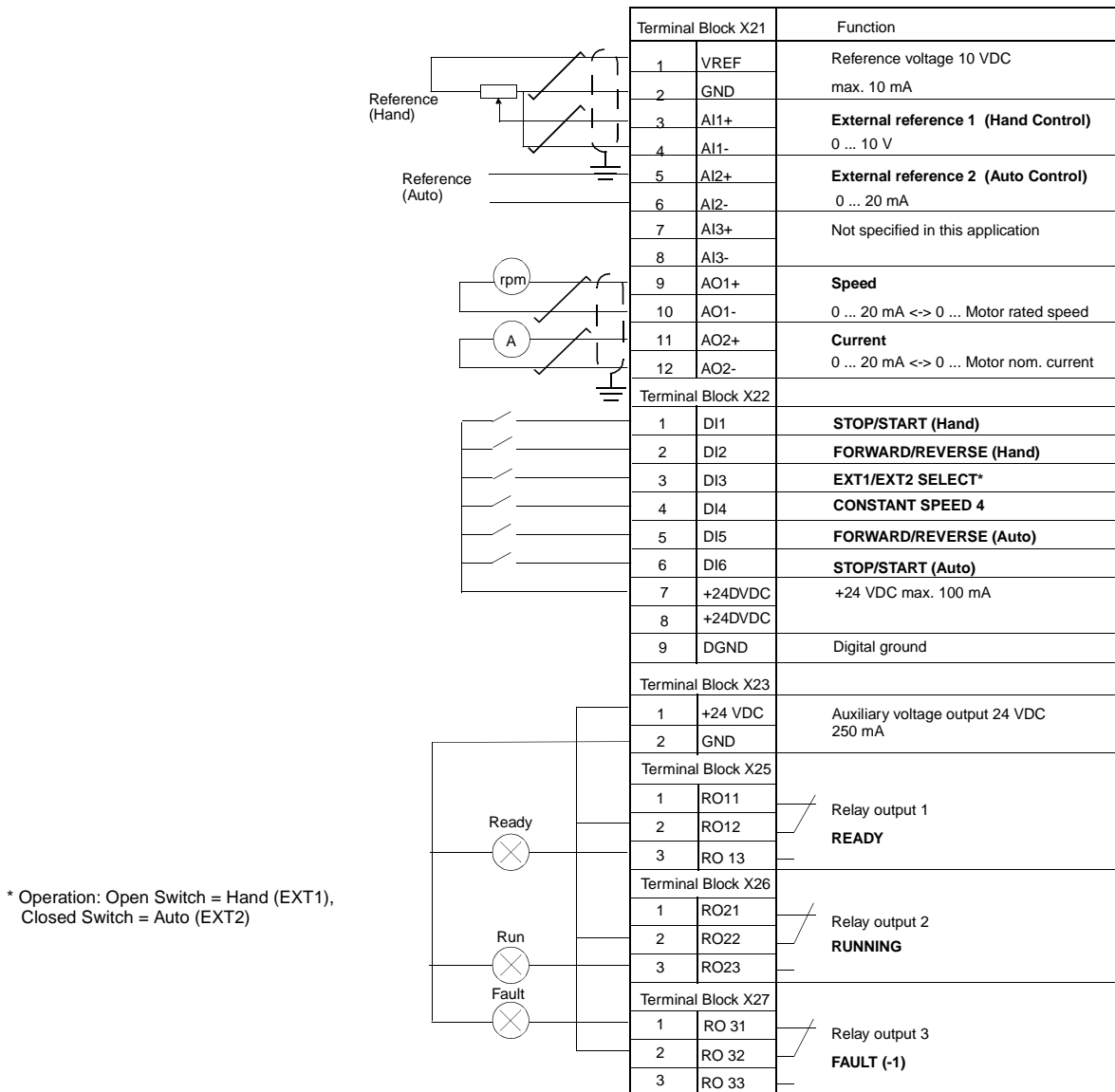

Figure 5-5 Control Connections for Hand/Auto Application Macro. The markings of the NIOC board terminals are given above. In ACS 601 and ACS 604, user connections are always made directly to the input and output terminals of the NIOC board. In ACS 607 the connections are made either directly to NIOC board, or the I/O terminals of the NIOC board are wired to a separate terminal block intended for the user connections. The separate terminal block is optional. See the appropriate hardware manual for the corresponding terminal markings.



**Control Signal Connections**

Control signals i.e. Reference, Start, Stop and Direction command connections are established as in Figure 5-6 when you select the Hand/Auto Macro.

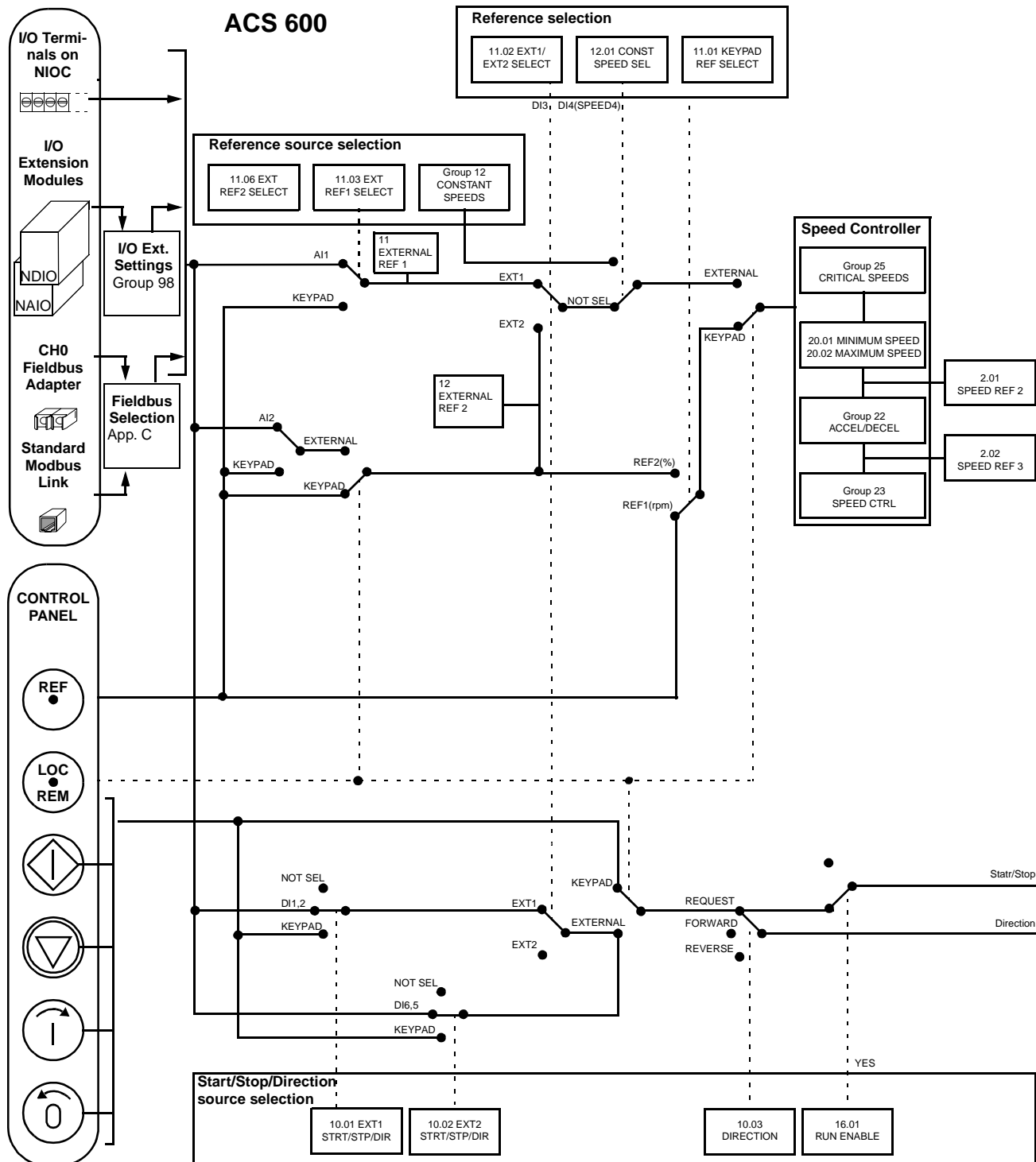

Figure 5-6 Control Signal connections for the Hand/Auto Macro.

**Application Macro 3 – PID Control**

The PID Control macro is used for controlling a process variable – such as pressure or flow – by controlling the speed of the driven motor.

Process reference signal is connected to analogue input AI1 and process feedback signal to analogue input AI2.

Alternatively, a direct speed reference can be given to the ACS 600 through analogue input AI1. Then the PID controller is bypassed and the ACS 600 no longer controls the process variable. Selection between the direct speed control and the process variable control is done with digital input DI3.

Two analogue and three relay output signals are available on terminal blocks. Default signals for the Actual Signal Display Mode of the Control Panel are SPEED, ACTUAL VALUE1 and CONTROL DEVIATION.

**Operation Diagram**

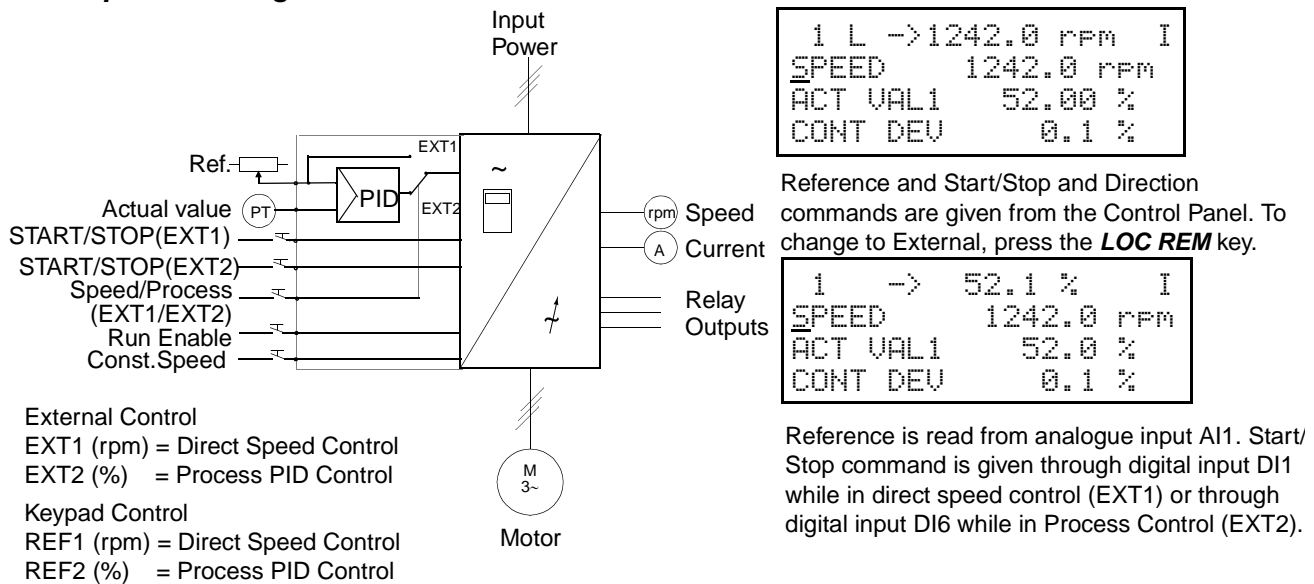

Figure 5-7 Operation Diagram for the PID Control Macro.

**Input and Output Signals**

Table 5-4 Input and Output Signal as set by the PID Control Macro.

Input Signals	Output Signals
START/STOP for each control location (DI1,DI6)	Speed (AO1)
Analogue Reference (AI1)	Current (AO2)
Actual Value (AI2)	READY (RO1)
Control Location Selection (DI3)	RUNNING (RO2)
Constant Speed Selection (DI4)	FAULT (-1) (RO3)
Run Enable (DI5)	

**Note:** Constant speeds (parameter Group 12) are not considered while the process reference is followed (PID controller is in use).

**External Connections** The following connection example is applicable when the PID Control Macro settings are used.

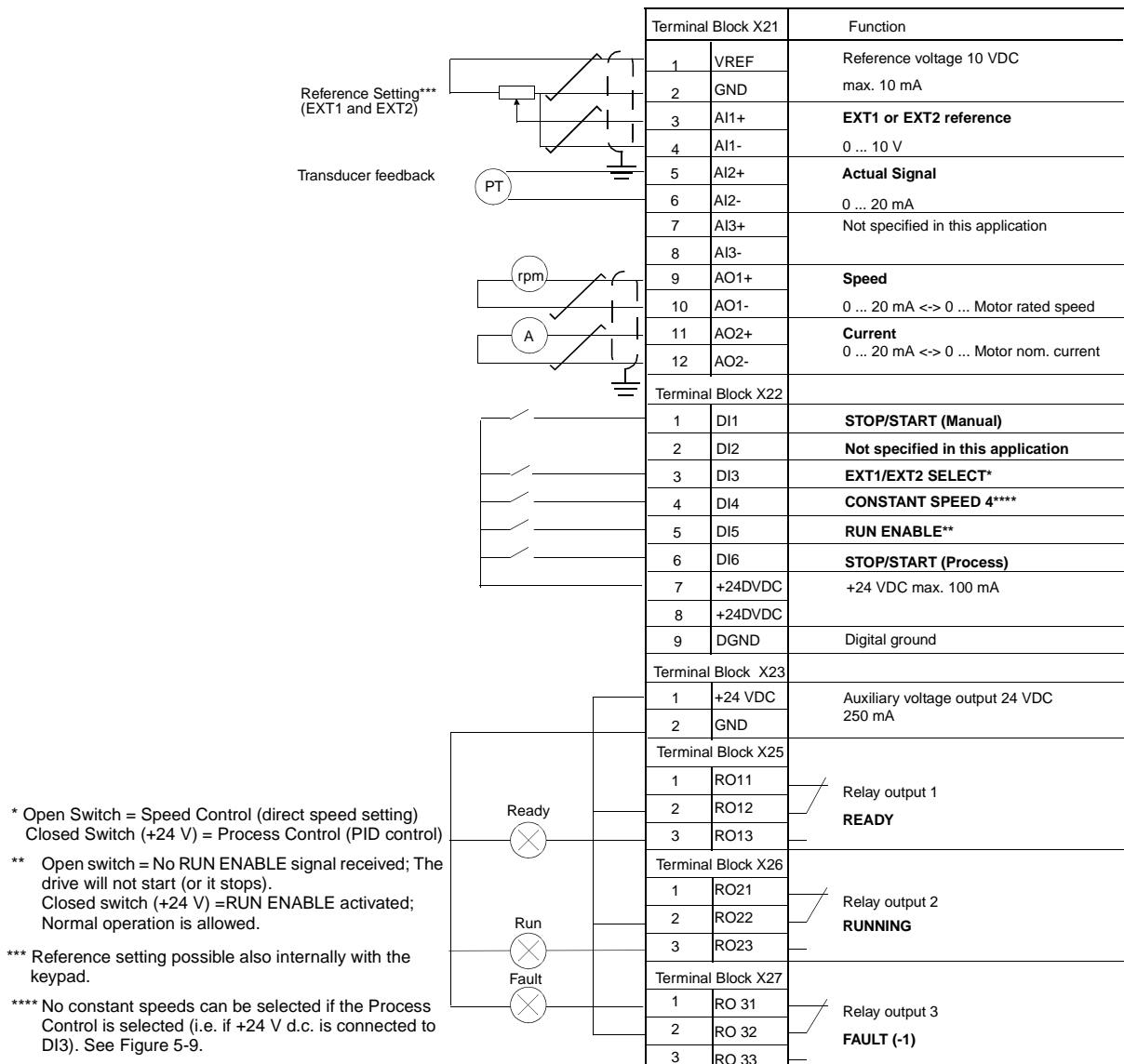

Figure 5-8 Control Connections for the PID Control Application Macro. The markings of the NIOC board terminals are given above. In ACS 601 and ACS 604, user connections are always made directly to the input and output terminals of the NIOC board. In ACS 607 the connections are made either directly to NIOC board, or the I/O terminals of the NIOC board are wired to a separate terminal block intended for the user connections. The separate terminal block is optional. See the appropriate hardware manual for the corresponding terminal markings.

**Control Signal Connections** Control signals i.e. Reference, Start, Stop and Direction command connections are established as in Figure 5-9 when you select the PID Control Macro.

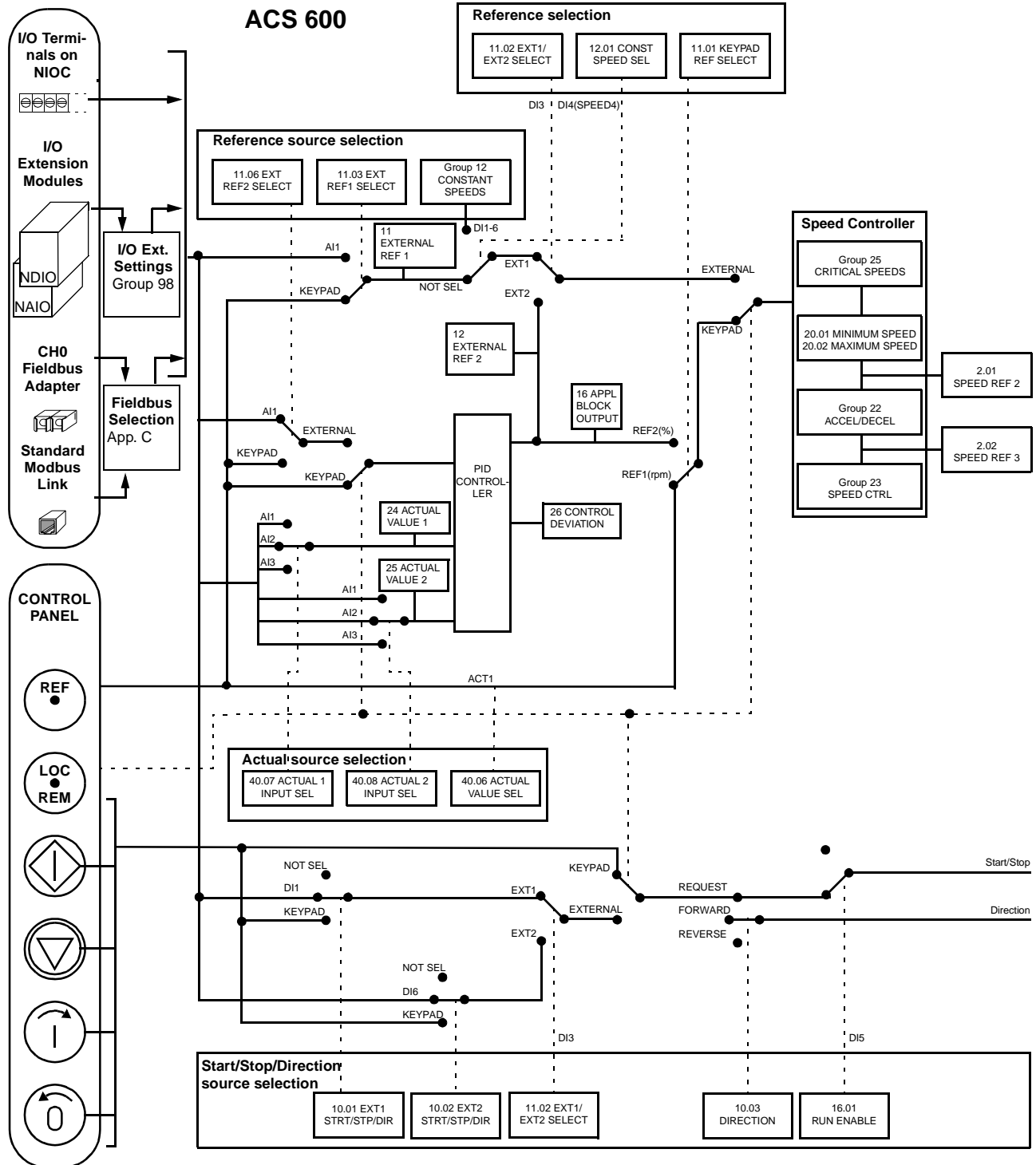

Figure 5-9 Control Signal connections for the PID Control Macro.

**Application Macro 4 – Torque Control**

Torque Control macro is used in applications that require torque control of the motor. Torque reference is given through analogue input AI2 as a current signal. By default, 0 mA corresponds to 0 %, and 20 mA to 100 % of the rated motor torque. The Start/Stop/Direction commands are given through digital inputs DI1 and DI2. The Run enable signal is connected to DI6.

Through digital input DI3 it is possible to select speed control instead of torque control. It is also possible to change the external control location to local (i.e. to Control Panel) by pressing the **LOC REM** key. The Panel controls the speed by default. If torque control with the Panel is required, the value of Parameter 11.01 KEYPAD REF SEL should be changed to REF2 (%).

Two analogue and three relay output signals are available on terminal blocks. Default signals for the Actual Signal Display Mode of the Control Panel are SPEED, TORQUE and CTRL LOC.

**Operation Diagram**

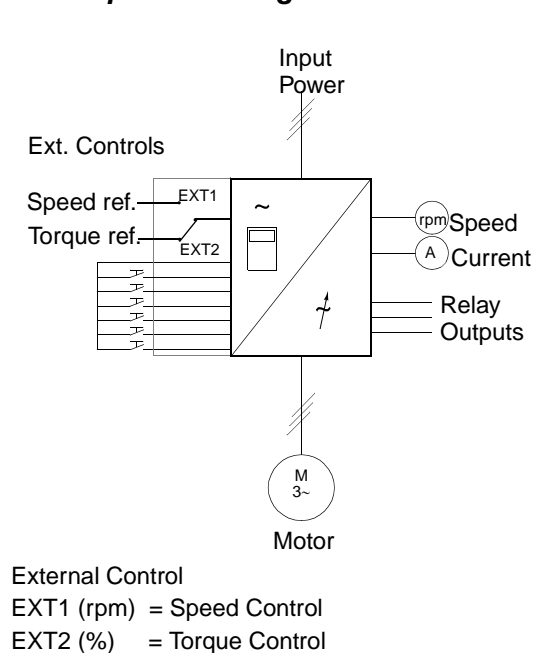

```

1 L ->1242.0 rpm I
SPEED  1242.0 rpm
TORQUE  66.00 %
CTRL LOC LOCAL
    
```

Reference and Start/Stop and Direction commands are given from the Control Panel. To change to External, press **LOC REM** key.

```

1 -> 50.0 % I
SPEED  1242.0 rpm
TORQUE  66.00 %
CTRL LOC EXT2
    
```

Reference is read from analogue input AI2 (torque control selected) or AI1 (speed control selected). Start/Stop and Direction commands are given through digital inputs DI1 and DI2. Selection between speed and torque control is done through DI3.

Keypad Control  
 REF1 (rpm) = Speed Control  
 REF2 (%) = Torque Control

Figure 5-10 Operation Diagram for the Torque Control Macro.

**Input and Output Signals**

Table 5-5 Input and Output Signals as set by the Torque Control Macro.

Input Signals	Output Signals
Start/Stop (DI1,2) Analogue Speed Reference (AI1) Analogue Torque Reference (AI2) Torque Control Selection (DI3) Accel/Decel 1/2 Selection (DI5) Constant Speed Selection (DI4) Run Enable (DI6)	Speed (AO1) Current (AO2) READY (RO1) RUNNING (RO2) FAULT (-1) (RO3)

**External Connections** The following connection example is applicable when the Torque Control Macro settings are used.

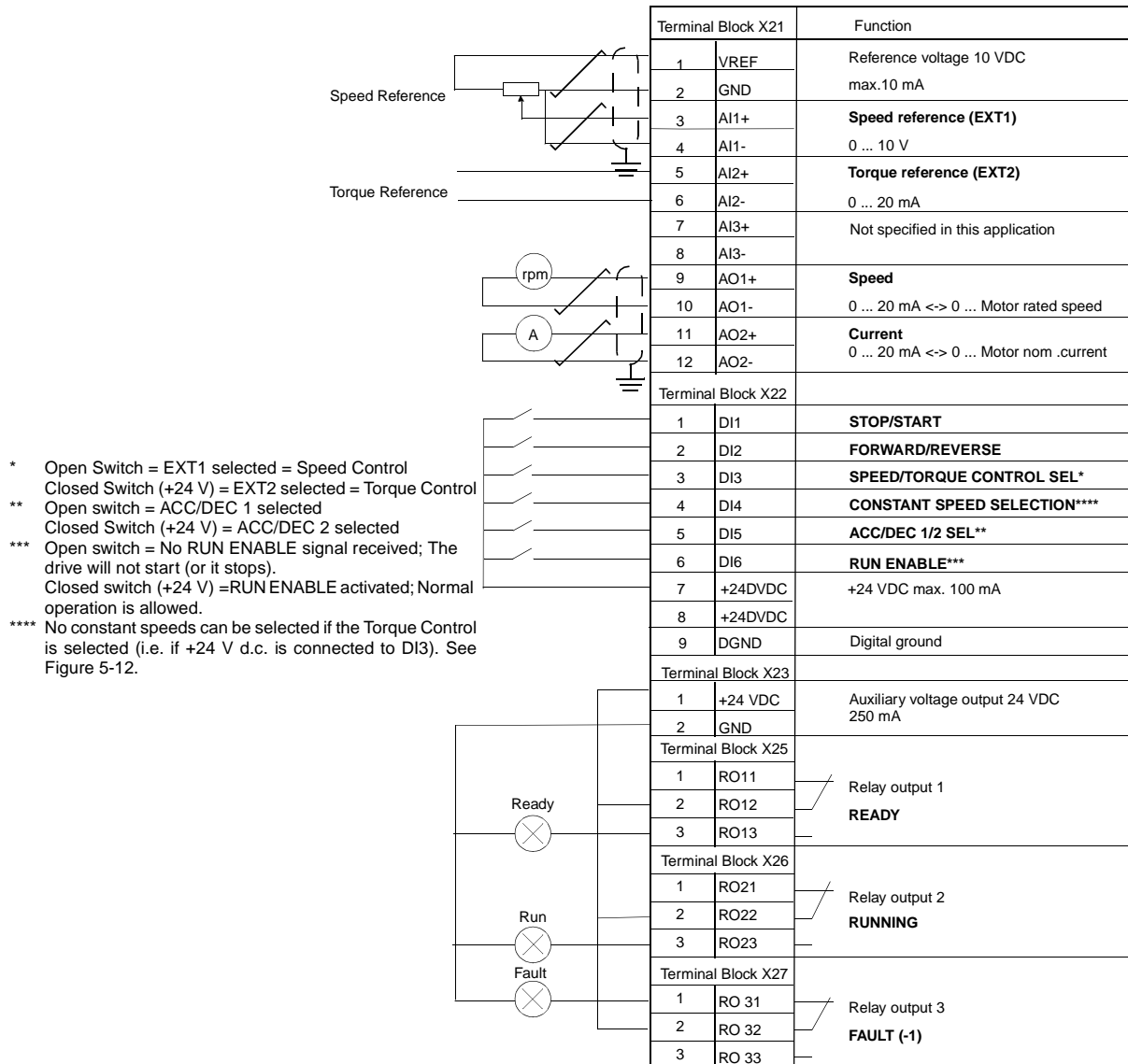

Figure 5-11 Control Connections for Torque Control Application Macro. The markings of the NIOC board terminals are given above. In ACS 601 and ACS 604, user connections are always made directly to the input and output terminals of the NIOC board. In ACS 607 the connections are made either directly to NIOC board, or the I/O terminals of the NIOC board are wired to a separate terminal block intended for the user connections. The separate terminal block is optional. See the appropriate hardware manual for the corresponding terminal markings.

**Control Signal Connections**

Control signals i.e. Reference, Start, Stop and Direction command connections are established as in Figure 5-12 when you select the Torque Control Macro.

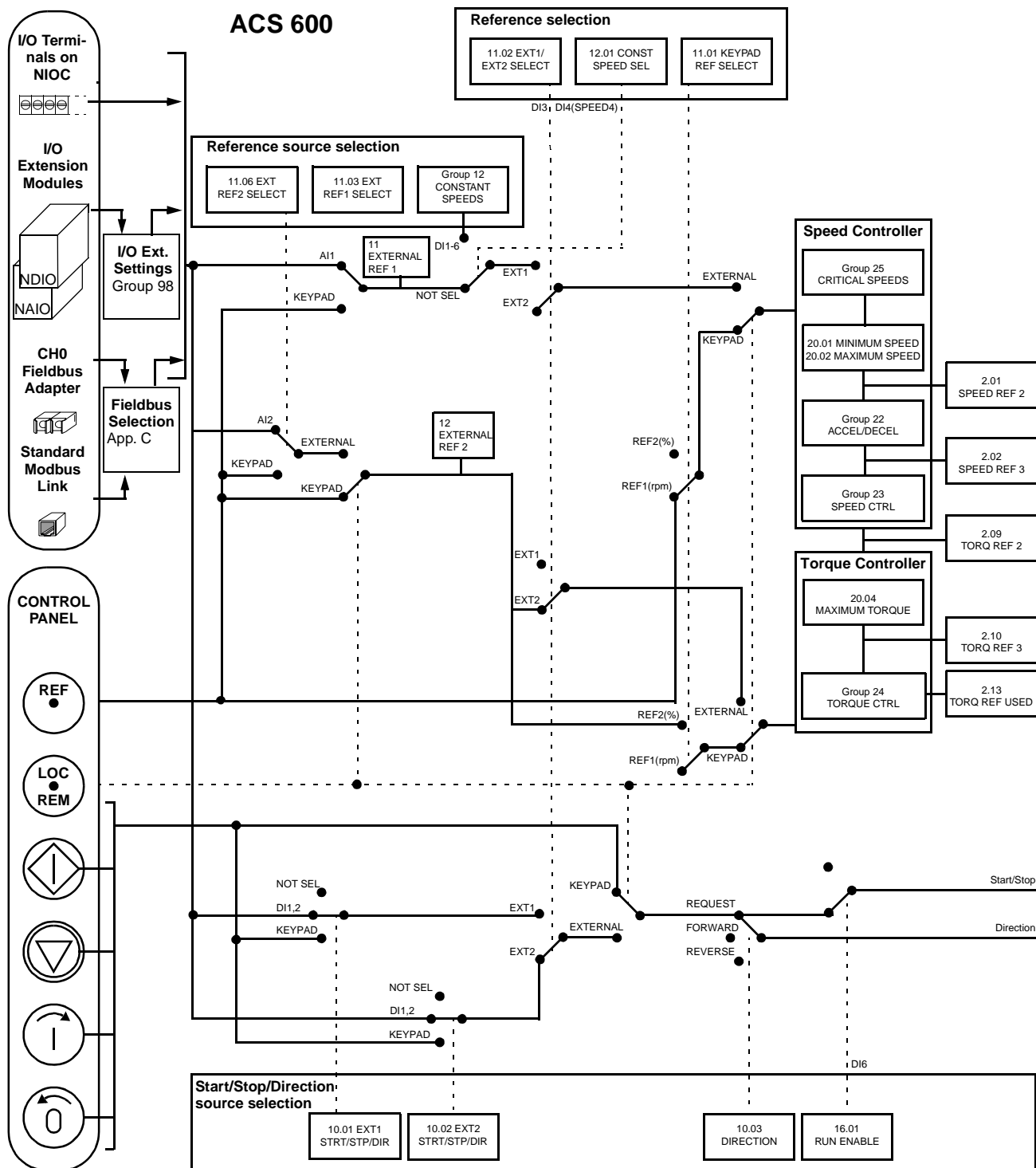

Figure 5-12 Control Signal connections for the Torque Control Macro.

**Application Macro 5 – Sequential Control**

This macro offers seven preset constant speeds, which can be activated by digital inputs DI4 to DI6 according to the Figure 5-16. Two acceleration/deceleration ramps are preset. The acceleration and deceleration ramps are applied according to the state of digital input DI3. The Start/Stop and Direction commands are given through digital inputs DI1 and DI2.

External speed reference can be given through analogue input AI1. It is active only when all of the digital inputs DI4 to DI6 are 0 VDC. Giving operational commands and setting reference is possible also from the Control Panel.

Two analogue and three relay output signals are available on terminal blocks. Default stop mode is ramp. Default signals for the Actual Signal Display Mode of the Control Panel are FREQUENCY, CURRENT and POWER.

**Operation Diagram**

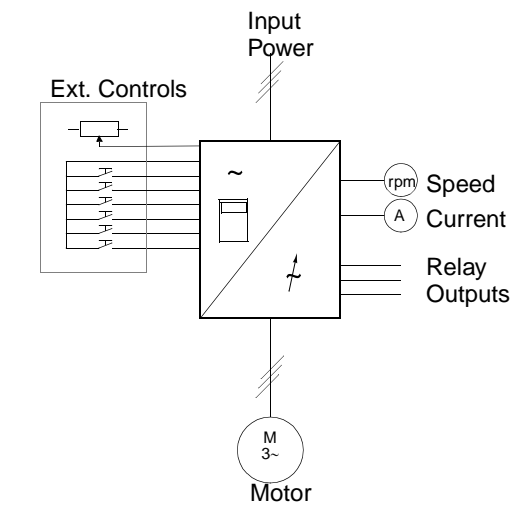

- External Control
- EXT1 (rpm) = Speed Control
- EXT2 (%) = Speed Control
- Keypad Control
- REF1 (rpm) = Speed Control
- REF2 (%) = Speed Control

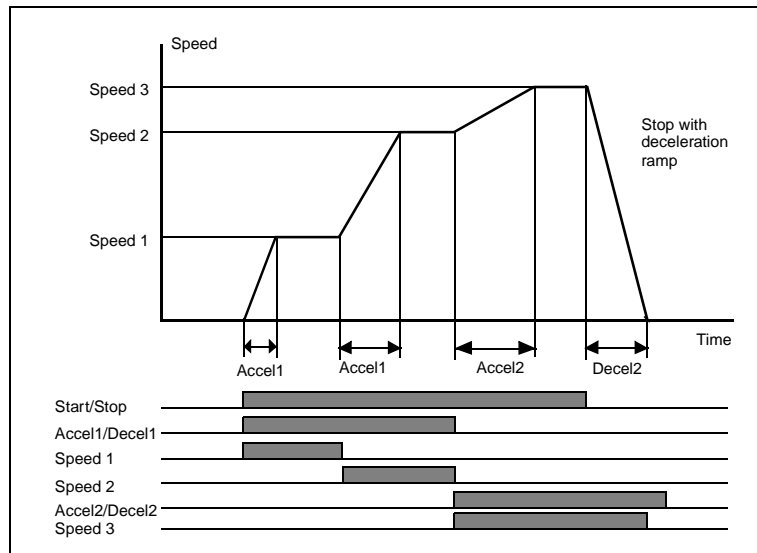

Example of sequential control using constant speeds and different acceleration and deceleration times.

Figure 5-13 Operation Diagram for the Sequential Control Macro.



Reference and Start/Stop and Direction commands are given from the Control Panel.

```

1 L ->1242.0 rpm I
FREQ      45.00 Hz
CURRENT   80.00 A
POWER     75.00 %
    
```

To change to External, press the **LOC REM** key.

Reference is read from analogue input AI1 or constant speed is used. Start/Stop and Direction commands are given through digital inputs DI1 and DI2.

```

1   ->1242.0 rpm I
FREQ      45.00 Hz
CURRENT   80.00 A
POWER     75.00 %
    
```

Figure 5-14 Keypad Control and External Control modes of the Sequential Control Macro.

**Input and Output Signals** Input and Output signals of the ACS 600 as set by the Sequential Control Macro are listed in Table 5-6.

Table 5-6 Input and Output Signals for Sequential Control Macro.

Input Signals	Output Signals
Start/Stop (DI1) and Reverse (DI2)	Speed (AO1)
Analogue Reference (AI1)	Current (AO2)
Accel/Decel 1/2 Selection (DI3)	READY (RO1)
Constant Speed Selection (DI4-6)	RUNNING (RO2)
	FAULT (-1) (RO3)

**External Connections** The following connection example is applicable when the Sequential Control Macro settings are used.

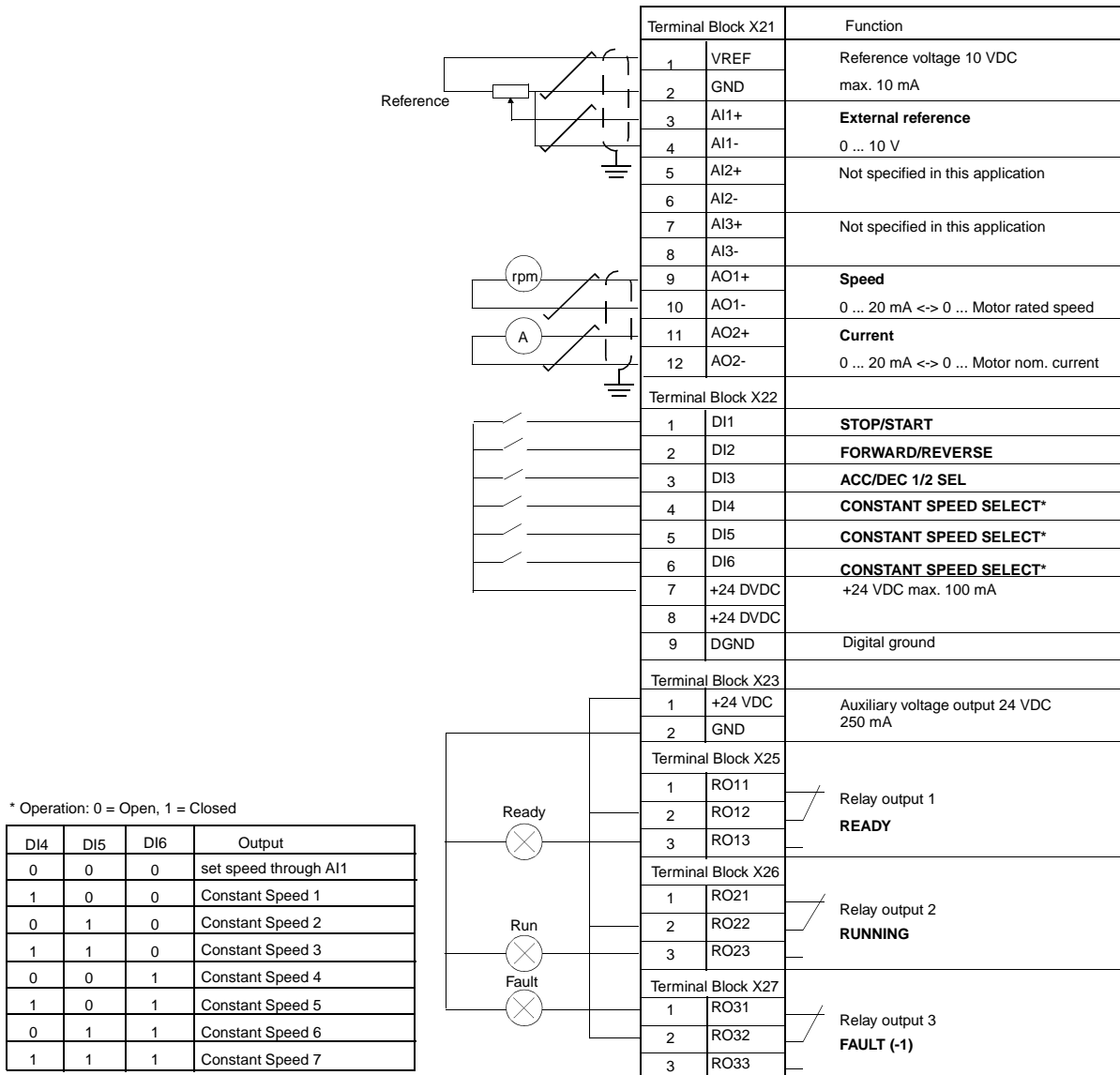

Figure 5-15 Control Connections for Sequential Control Application Macro. The markings of the NIOC board terminals are given above. In ACS 601 and ACS 604, user connections are always made directly to the input and output terminals of the NIOC board. In ACS 607 the connections are made either directly to NIOC board, or the I/O terminals of the NIOC board are wired to a separate terminal block intended for the user connections. The separate terminal block is optional. See the appropriate hardware manual for the corresponding terminal markings.

**Control Signal Connections**

Control signals i.e. Reference, Start, Stop and Direction command connections are established as in Figure 5-16 when you select the Sequential Control Macro.

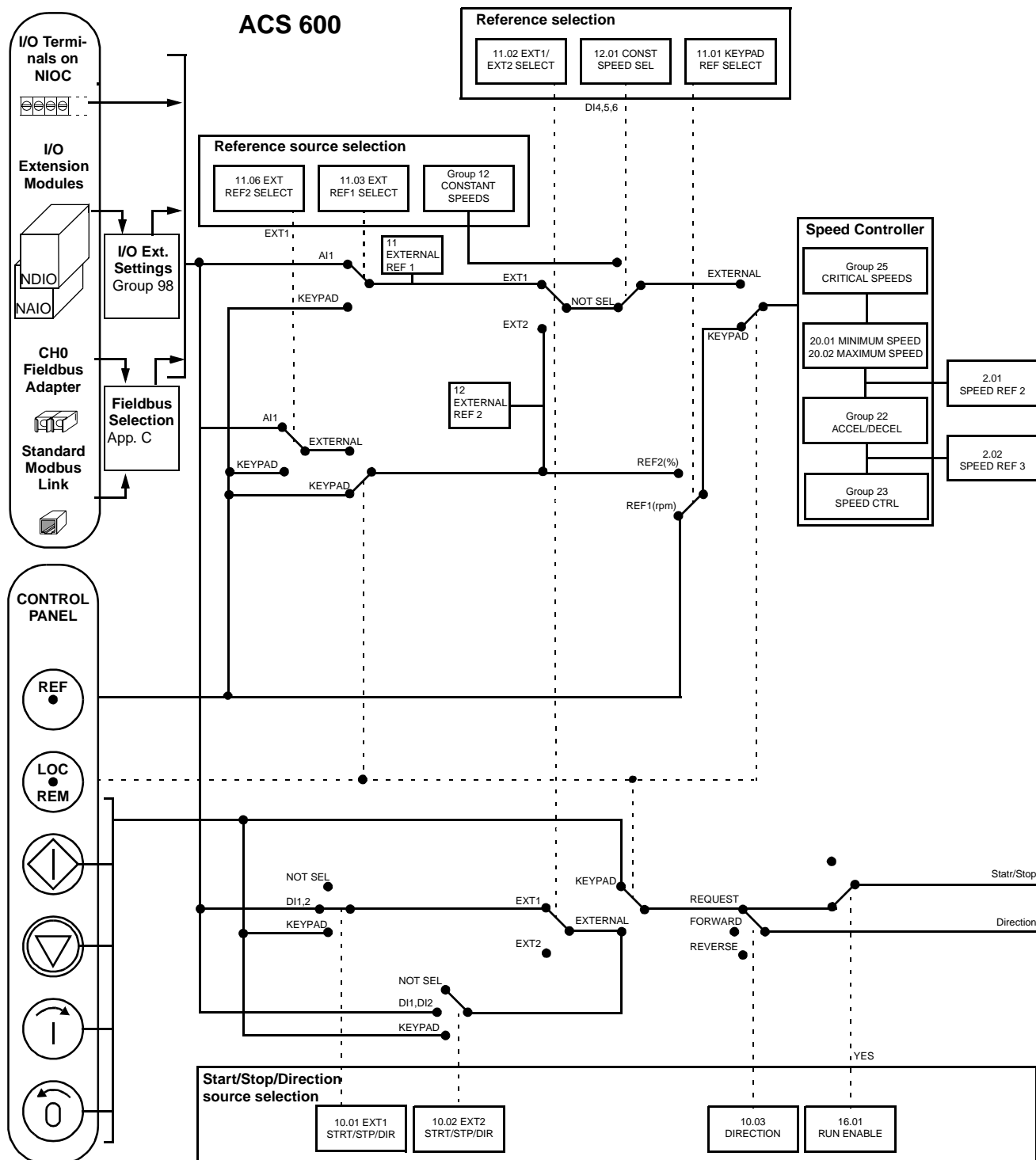

Figure 5-16 Control Signal connections for the Sequential Control Macro.



# Chapter 6 – Parameters

## Overview

This chapter explains the function of, and valid selections for, each ACS 600 parameter.

## Parameter Groups

The ACS 600 parameters are arranged into groups by their function. Figure 6-1 illustrates the organisation of the parameter groups. *Chapter 2 – Overview of ACS 600 Programming...* explains how to select and set the parameters. Refer to *Chapter 3 – Start-up Data* and *Chapter 4 – Control Operation* for more information on the Start-up Data and Actual Signals. Some parameters that are not in use in the current application are hidden to simplify programming.

**CAUTION!** Exercise caution when configuring input/output connections, as it is possible (albeit not recommended) to use one I/O connection to control several operations. If an I/O is programmed for some purpose the setting remains, even if you select the I/O for another purpose with another parameter.

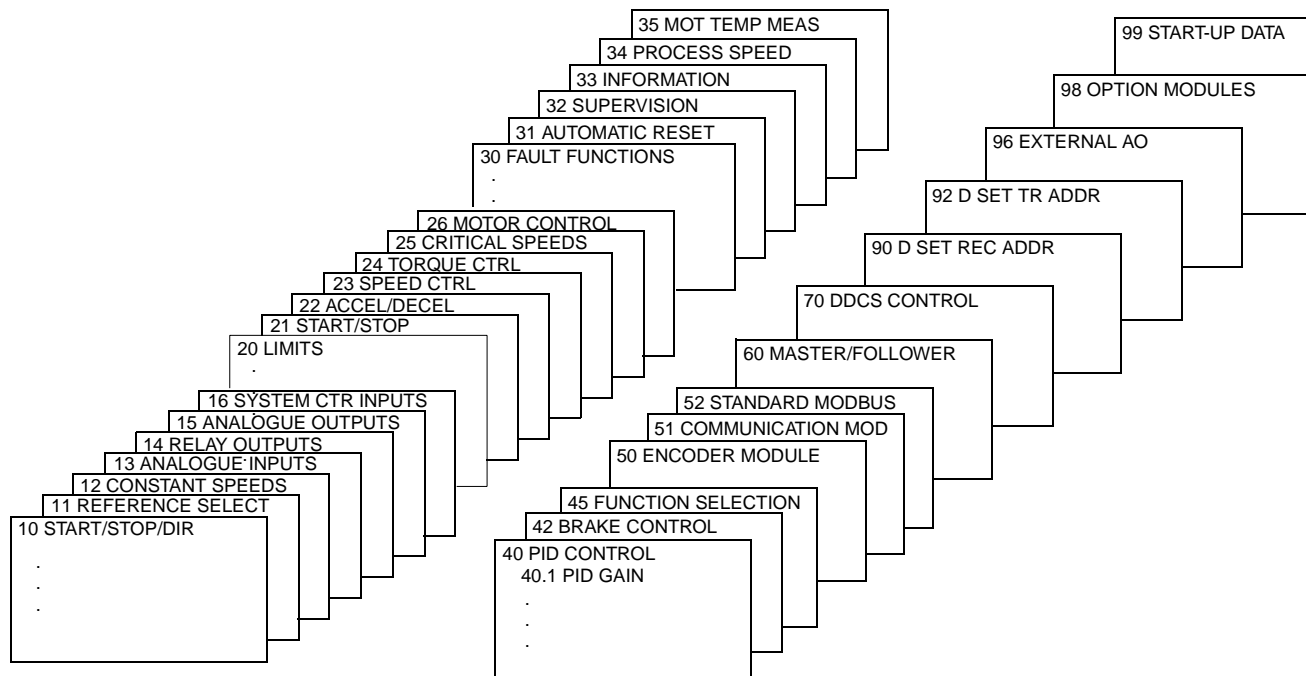

Figure 6-1 Parameter Groups.

**Group 10 Start/Stop/Dir**

These parameter values can only be altered with the ACS 600 stopped. The Range/Unit column in Table 6-1 shows the allowable parameter values. The text following the table explains the parameters in detail.

Table 6-1 Group 10.

Parameter	Range/Unit	Description
1 EXT1 STRT/STP/DIR	NOT SEL; Digital Inputs; KEYPAD; COMM. MODULE	Selects source of Start/Stop/ Direction commands for External control location EXT1.
2 EXT2 STRT/STP/DIR	NOT SEL; Digital Inputs; KEYPAD; COMM. MODULE	Selects source of Start/Stop/ Direction commands for External control location EXT2.
3 DIRECTION	FORWARD; REVERSE; REQUEST	Rotation direction lock.

Start, Stop and Direction commands can be given from the keypad or from two external locations. The selection between the two external locations is made with Parameter 11.02 EXT1/EXT2 SELECT. For more information on control locations refer to *Chapter 4 – Control Operation*.

**10.01 EXT1  
STRT/STP/DIR**

This parameter defines the connections and the source of Start, Stop and Direction commands for External control location 1 (EXT1).

**NOT SEL**

No Start, Stop and Direction command source for EXT1 is selected.

**D11**

Two-wire Start/Stop, connected to digital input D11. 0 V DC on D11 = Stop; 24 V DC on D11 = Start. Direction of rotation is fixed according to Parameter 10.3 DIRECTION.



**WARNING!** After a fault reset, the drive will start if the start signal is on.

**D11,2**

Two-wire Start/Stop. Start/Stop is connected to digital input D11 as above. Direction is connected to digital input D12. 0 V DC on D12 = Forward; 24 V DC on D12 = Reverse. To control Direction, value of Parameter 10.3 DIRECTION should be REQUEST.



**WARNING!** After a fault reset, the drive will start if the start signal is on.

**DI1P,2P**

Three-wire Start/Stop. Start/Stop commands are given by means of momentary push-buttons (the P stands for “pulse”). The Start push-button is normally open, and connected to digital input DI1. The Stop push-button is normally closed, and connected to digital input DI2. Multiple Start push-buttons are connected in parallel; multiple Stop push-buttons are connected in series. Direction of rotation is fixed according to Parameter 10.03 DIRECTION.

**DI1P,2P,3**

Three-wire Start/Stop. Start/Stop connected as with DI1P,2P. Direction is connected to digital input DI3. 0 V DC on DI3 = Forward; 24 V DC on DI3 = Reverse. To control Direction, value of Parameter 10.03 DIRECTION should be REQUEST.

**DI1P,2P,3P**

Start Forward, Start Reverse, and Stop. Start and Direction commands are given simultaneously with two separate momentary push-buttons (the P stands for “pulse”). The Stop push-button is normally closed, and connected to digital input DI3. The Start Forward and Start Reverse push-buttons are normally open, and connected to digital inputs DI1 and DI2 respectively. Multiple Start push-buttons are connected in parallel, and multiple Stop push-buttons are connected in series. To control Direction, value of Parameter 10.03 DIRECTION should be REQUEST.

**DI6**

Two-wire Start/Stop, connected to digital input DI6. 0 V DC on DI6 = Stop and 24 V DC on DI6 = Start. Direction of rotation is fixed according to Parameter 10.03 DIRECTION.



**WARNING!** After a fault reset, the drive will start if the start signal is on.

---

**DI6,5**

Two-wire Start/Stop. Start/Stop is connected to digital input DI6. Direction is connected to digital input DI5. 0 V DC on DI5 = Forward and 24 V DC on DI5 = Reverse. To control Direction, value of Parameter 10.03 DIRECTION should be REQUEST.



**WARNING!** After a fault reset, the drive will start if the start signal is on.

---

**KEYPAD**

The Start/Stop and Direction commands are given from the Control Panel keypad when External control location 1 is active. To control Direction, value of Parameter 10.03 DIRECTION should be REQUEST.

**COMM. MODULE**

The Start/Stop and Direction commands are given through Fieldbus Control Word. See *Appendix C – Fieldbus Control*.

**DI7; DI7,8; DI7P,8P; DI7P,8P,9; DI7P,8P,9P**

For the connection of digital inputs DI7, DI8 and DI9, see *Parameter Group 98 Option Modules*. For the function descriptions, see the corresponding selections implemented using DI1, DI2 and DI3.

**10.02 EXT2  
STRT/STP/DIR**

This parameter defines the connections and the source of Start, Stop and Direction commands for External control location 2 (EXT2).

**NOT SEL; DI1; DI1,2; DI1P,2P; DI1P,2P,3; DI1P,2P,3P; DI6; DI6,5;  
KEYPAD; COMM. MODULE; DI7; DI7,8; DI7P,8P; DI7P,8P,9;  
DI7P,8P,9P**

Refer to Parameter 10.01 EXT1 STRT/STP/DIR above for details on these settings.

**10.03 DIRECTION**

This parameter allows you to fix the direction of rotation of the motor to **FORWARD** or **REVERSE**. If you select **REQUEST**, the direction is selected as defined by Parameters 10.01 EXT1 STRT/STP/DIR and 10.02 EXT2 STRT/STP/DIR or by keypad push-buttons.



**Group 11 Reference Select**

These parameter values can be altered with the ACS 600 running, except those marked with (O). The Range/Unit column in Table 6-2 shows the allowable parameter values. The text following the table explains the parameters in detail.

Table 6-2 Group 11.

Parameter	Range/Unit	Description
1 KEYPAD REF SEL	REF1 (rpm); REF2 (%)	Selection of active keypad reference.
2 EXT1/EXT2 SELECT (O)	DI1 ... DI12; EXT1; EXT2; COMM. MODULE	External control location selection input.
3 EXT REF1 SELECT (O)	KEYPAD; Analogue and Digital Inputs; COMM. REF; COMMREF+AI1; COMMREF*AI1; FAST COMM; COMMREF+AI5; COMMREF*AI5;	External reference 1 input.
4 EXT REF1 MINIMUM	(0 ... 18000) rpm	External reference 1 minimum value.
5 EXT REF1 MAXIMUM	(0 ... 18000) rpm	External reference 1 maximum value.
6 EXT REF2 SELECT (O)	KEYPAD; Analogue and Digital Inputs; COMM. REF; COMMREF+AI1; COMMREF*AI1; FAST COMM; COMMREF+AI5; COMMREF*AI5	External reference 2 input.
7 EXT REF2 MINIMUM	0 ... 100 %	External reference 2 minimum value.
8 EXT REF2 MAXIMUM	0 ... 500 %	External reference 2 maximum value.

Reference can be set from the keypad or from two external locations. Refer to *Chapter 4 – Control Operation*.

**11.01 KEYPAD REF SEL****REF1 (rpm)**

Keypad reference 1 is selected as the active keypad reference. The type of the reference is speed, given in rpm. If scalar control is selected (Parameter 99.04 is set to SCALAR), the reference is given in Hz.

**REF2 (%)**

Keypad reference 2 is selected as the active keypad reference. Keypad reference 2 is given in %. The type of Keypad reference 2 depends on the selected Application Macro. For example, if the Torque Control macro is selected, REF 2 (%) is torque reference.

11.02 EXT1/EXT2  
SELECT (O)

This parameter sets the input used for selecting the external control location, or fixes it to EXT1 or EXT2. The external control location of both Start/Stop/Direction commands and reference is determined by this parameter.

**EXT1**

External control location 1 is selected. The control signal sources for EXT1 are defined with Parameter 10.01 EXT1 STRT/STP/DIR and Parameter 11.03 EXT REF1 SELECT (O).

**EXT2**

External control location 2 is selected. The control signal sources for EXT2 are defined with Parameter 10.02 EXT2 STRT/STP/DIR and Parameter 11.06 EXT REF2 SELECT (O).

**DI1 - DI12**

External control location 1 or 2 is selected according to the state of the selected digital input (DI1 ... DI12), where 0 V DC = EXT1 and 24 V DC = EXT2. For the connection of DI7 to DI12, see *Group 98 Option Modules*.

**COMM. MODULE**

External control location 1 or 2 is chosen through Fieldbus Control Word. See *Appendix C – Fieldbus Control*.

11.03 EXT REF1  
SELECT (O)

This parameter selects the signal source of External reference 1.

**KEYPAD**

Reference is given from the Keypad. The first line on the display shows the reference value.

**AI1**

Reference from analogue input 1 (voltage signal).

**AI2**

Reference from analogue input 2 (current signal).

**AI3**

Reference from analogue input 3 (current signal).

**AI1/JOYST; AI2/JOYST**

Reference from analogue input 1 (or 2 accordingly) configured for a joystick. The minimum input signal runs the drive at maximum reference in the reverse direction. The maximum input signal runs the drive at maximum reference in the forward direction (See Figure 6-2). See also Parameter 10.03 DIRECTION.

---

**CAUTION:** Minimum reference for joystick must be higher than 0.5 V. If a 0 ... 10 V signal is used, the ACS 600 will operate at maximum reference in the reverse direction if the control signal is lost. Set Parameter 13.01 MINIMUM AI1 to 2 V or to a value higher than 0.5 V, and Parameter 30.01 AI<MIN FUNCTION to FAULT, and the ACS 600 will stop in case the control signal is lost.

---

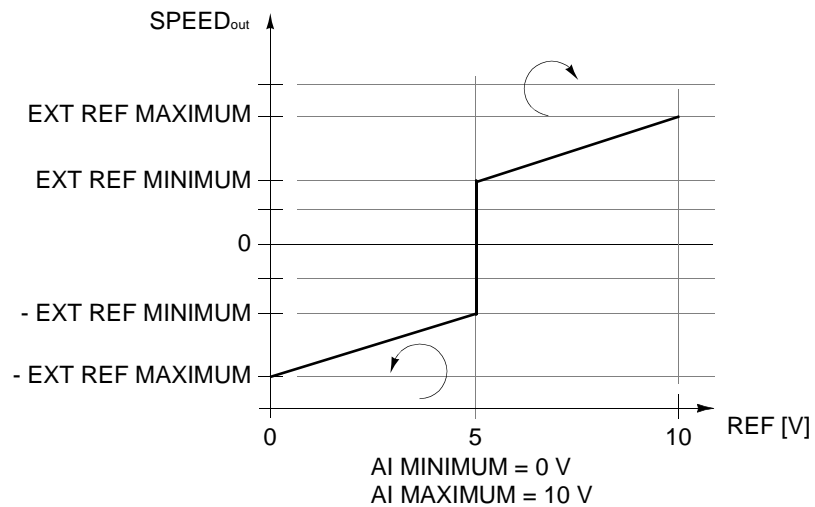

Figure 6-2 Joystick control. Maximum for the external reference 1 is set with Parameter 11.05 EXT REF1 MAXIMUM and minimum with Parameter 11.04 EXT REF1 MINIMUM.

**AI1+AI3; AI2+AI3; AI1-AI3; AI2-AI3; AI1\*AI3; AI2\*AI3; MIN(AI1,AI3); MIN(AI2,AI3); MAX(AI1,AI3); MAX(AI2,AI3)**

The reference is calculated from the selected input signals according to the mathematical functions defined by this setting.

#### **DI3U,4D(R)**

Speed reference is given through digital inputs as motor potentiometer control (or Floating Point Control). Digital input DI3 increases the speed (the U stands for “up”), and digital input DI4 decreases the speed (the D stands for “down”). (R) indicates that the reference will be reset to zero when a Stop command is given. The rate of change of the reference signal is controlled by Parameter 22.04 ACCEL TIME 2.

#### **DI3U,4D**

Same as above, except that the speed reference is not reset to zero on a Stop command or when power is switched off. When the ACS 600 is started, the motor will ramp up at the selected acceleration rate to the stored reference.

#### **DI5U,6D**

Same as above, except that the digital inputs in use are DI5 and DI6.

#### **COMM. REF**

The reference is given through fieldbus reference REF1. See *Appendix C – Fieldbus Control*.

#### **COMMREF+AI1; COMMREF\*AI1;**

The reference is given through fieldbus reference REF1. The analogue input signal 1 is combined to the fieldbus reference (sum or multiplication). See *Appendix C – Fieldbus Control* for more information.

### FAST COMM

As with the selection COMM. REF, the reference is given through fieldbus reference REF1. See *Appendix C – Fieldbus Control*. The FAST COMM differs from the COMM. REF as follows:

- shorter communication cycle time when transferring the reference to the core motor control program (6 ms -> 2ms)
- the direction cannot be controlled through interfaces defined by Parameters 10.01 EXT1 STRT/STP/DIR or 10.02 EXT2 STRT/STP/DIR, nor from the control panel.
- *Group 25 Critical Speeds* is not effective

**Note:** If any of the following selections is true, the selection FAST COMM is not effective. Instead, the operation is according to selection COMM. REF.

- 99.02 APPLICATION MACRO is PID
- 99.04 MOTOR CTRL MODE is SCALAR
- 40.14 TRIM MODE is PROPORTIONAL or DIRECT

### COMMREF+AI5; COMMREF\*AI5

The reference is given through fieldbus reference REF1. The analogue input signal AI5 is combined to the fieldbus reference (sum or multiplication). See *Appendix C – Fieldbus Control* for more information. For the connection of analogue input AI5, see *Group 98 Option Modules*.

### AI5; AI6; AI5/JOYST; AI6/JOYST; AI5+AI6; AI5-AI6; AI5\*AI6; MIN(AI5,6); MAX(AI5,6)

For the function description, see the corresponding selection described for AI1 and AI2 above. For the connection of analogue inputs AI5 and AI6, see *Group 98 Option Modules*.

### DI11U,12D(R);DI11U,12D

For the function description, see the corresponding selection described for DI3 and DI4 above. For the connection of digital inputs DI11 and DI12, see *Group 98 Option Modules*.

### 11.04 EXT REF1 MINIMUM

This parameter sets the minimum speed reference in rpm. The value corresponds to the minimum of the analogue input signal connected to REF1 (value of Parameter 11.03 EXT REF1 SELECT (O) is AI1, AI2 or AI3). See Figure 6-3. In the SCALAR control mode (see 99.04 MOTOR CTRL MODE), this parameter is given in Hz.

**Note:** If the reference is given through fieldbus, the scaling differs from that of an analogue signal. See *Appendix C – Fieldbus Control* for more information.

- 11.05 EXT REF1  
MAXIMUM** This parameter sets the maximum speed reference in rpm. The value corresponds to the maximum of the analogue input signal connected to REF1 (value of Parameter 11.03 EXT REF1 SELECT (O) is AI1, AI2 or AI3). See Figure 6-3. In the SCALAR control mode (see Parameter 99.04 MOTOR CTRL MODE), this parameter is given in Hz.
- Note:** If the reference is given through fieldbus, the scaling differs from that of an analogue signal. See *Appendix C – Fieldbus Control* for more information.
- 11.06 EXT REF2  
SELECT (O)** This parameter selects the signal source for External reference 2. The alternatives are the same as with External reference 1.
- 11.07 EXT REF2  
MINIMUM** This parameter sets the minimum reference in percent. The value corresponds to the minimum of the analogue input signal connected to REF2 (value of 11.06 EXT REF2 SELECT (O) is AI1, AI2 or AI3). See Figure 6-3.
- If the Factory, Hand/Auto or Sequential Control macro is selected, this parameter sets the minimum speed reference. The value is given as a percentage of the maximum speed defined with Parameter 20.02 MAXIMUM SPEED, or 20.01 MINIMUM SPEED if the absolute value of the minimum limit is greater than the maximum limit.
  - If the Torque Control macro is selected, this parameter sets the minimum torque reference. The value is given as a percentage of the nominal torque.
  - If the PID Control macro is selected, this parameter sets the minimum process reference. The value is given as a percentage of the maximum process quantity.
- In the SCALAR control mode (see Parameter 99.04 MOTOR CTRL MODE), this value is given as a percentage of the maximum frequency defined with Parameter 20.08 MAXIMUM FREQ, or 20.07 MINIMUM FREQ if the absolute value of the minimum limit is greater than the maximum limit.
- Note:** If the reference is given through fieldbus, the scaling differs from that of an analogue signal. See *Appendix C – Fieldbus Control* for more information.
- 11.08 EXT REF2  
MAXIMUM** This parameter sets the maximum reference in percent. The value corresponds to the maximum of the analogue signal connected to REF2 (value of 11.06 EXT REF2 SELECT (O) is AI1, AI2 or AI3). See Figure 6-3.
- If the Factory, Hand/Auto or Sequential Control macro is selected, this parameter sets the maximum speed reference. The value is given as a percentage of the maximum speed defined with Parameter 20.02 MAXIMUM SPEED, or 20.01 MINIMUM SPEED if the absolute value of the minimum limit is greater than the maximum limit.

- If the Torque Control macro is selected, this parameter sets the maximum torque reference. The value is given as a percentage of the nominal torque.
- If the PID Control macro is selected, this parameter sets the maximum process reference. The value is given as a percentage of the maximum process quantity.

In the SCALAR control mode (see Parameter 99.04 MOTOR CTRL MODE), this value is given as a percentage of the maximum frequency defined with Parameter 20.08 MAXIMUM FREQ, or 20.07 MINIMUM FREQ if the absolute value of the minimum limit is greater than the maximum limit.

**Note:** If the reference is given through fieldbus, the scaling differs from that of an analogue signal. See *Appendix C – Fieldbus Control* for more information.

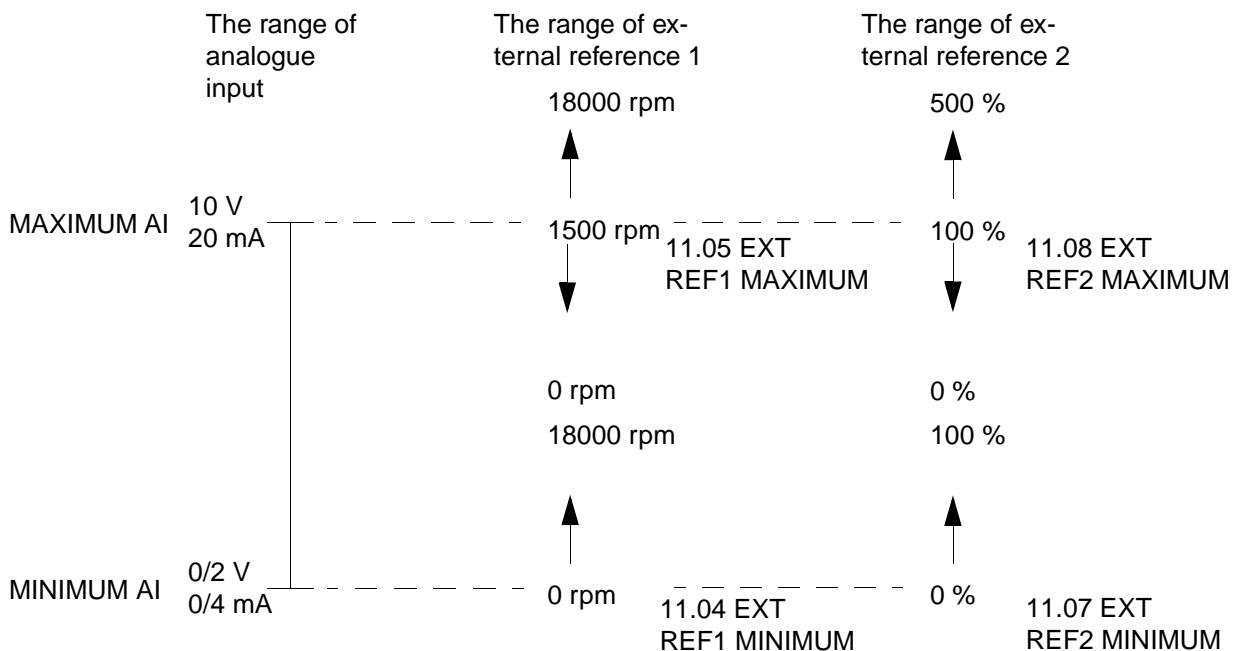

Figure 6-3 Setting EXT REF MINIMUM and MAXIMUM. The range of the analogue input signal is set by Parameter 13.02 MAXIMUM AI1, 13.07 MAXIMUM AI2, 13.12 MAXIMUM AI3 and Parameter 13.01 MINIMUM AI1, 13.06 MINIMUM AI2, 13.11 MINIMUM AI3, depending on the analogue input used.

**Group 12 Constant Speeds**

These parameter values can be altered with the ACS 600 running, except those marked with (O). The Range/Unit column in Table 6-3 below shows the allowable parameter values. The text following the table explains the parameters in detail.

Table 6-3 Group 12.

Parameter	Range/Unit	Description
1 CONST SPEED SEL (O)	NOT SEL; Digital Inputs	Constant speed selection
2 CONST SPEED 1	0 ... 18000 rpm	Constant speed 1
3 CONST SPEED 2	0 ... 18000 rpm	Constant speed 2
4 CONST SPEED 3	0 ... 18000 rpm	Constant speed 3
5 CONST SPEED 4	0 ... 18000 rpm	Constant speed 4
6 CONST SPEED 5	0 ... 18000 rpm	Constant speed 5
7 CONST SPEED 6	0 ... 18000 rpm	Constant speed 6
8 CONST SPEED 7	0 ... 18000 rpm	Constant speed 7
9 CONST SPEED 8	0 ... 18000 rpm	Constant speed 8
10 CONST SPEED 9	0 ... 18000 rpm	Constant speed 9
11 CONST SPEED 10	0 ... 18000 rpm	Constant speed 10
12 CONST SPEED 11	0 ... 18000 rpm	Constant speed 11
13 CONST SPEED 12	0 ... 18000 rpm	Constant speed 12
14 CONST SPEED 13	0 ... 18000 rpm	Constant speed 13
15 CONST SPEED 14	0 ... 18000 rpm	Constant speed 14
16 CONST SPEED 15	-18000 ... 18000 rpm	Constant speed 15/ Fault speed

If a constant speed is activated, the absolute value of the speed is read from parameter group 12. The sign of speed no. 15 is considered when used as a Fault Speed (see Parameters 30.01 AI<MIN FUNCTION and 30.02 PANEL LOSS).

In External Control, when External Control Location EXT 1 is selected, constant speeds override other speed references. Constant speed selections are ignored if the torque reference or process PID reference is followed (see the Torque Control and PID Control Macros).

In the SCALAR control mode (see Parameter 99.04 MOTOR CTRL MODE), six constant frequencies can be set with Parameters 12.02 to 12.06 and 12.15. By default, the parameter values are set to zero Hz.

**12.01 CONST SPEED SEL**

This parameter defines which digital inputs are used to select Constant Speeds.

**NOT SEL**

Constant speed function disabled.

**DI1(SPEED1); DI2(SPEED2); DI3(SPEED3); DI4(SPEED4); DI5(SPEED5); DI6(SPEED6)**

Constant Speeds 1-6 selected with digital inputs DI1-DI6. 24 V DC = Constant Speed activated.

**DI1,2**

Three Constant Speeds (1 ... 3) are selected with two digital inputs.

*Table 6-4 Constant Speed selection with digital inputs DI1,2.*

DI1	DI2	Function
0	0	No Constant Speed
1	0	Constant Speed 1
0	1	Constant Speed 2
1	1	Constant Speed 3

**DI3,4**

Three Constant Speeds (1 ... 3) are selected with two digital inputs as in DI1,2.

**DI5,6**

Three Constant Speeds (1 ... 3) are selected with two digital inputs as in DI1,2.

**DI1,2,3**

Seven Constant Speeds (1 ... 7) are selected with three digital inputs.

*Table 6-5 Constant Speed selection with digital inputs DI1,2,3.*

DI1	DI2	DI3	Function
0	0	0	No Const. Speed
1	0	0	Constant Speed 1
0	1	0	Constant Speed 2
1	1	0	Constant Speed 3
0	0	1	Constant Speed 4
1	0	1	Constant Speed 5
0	1	1	Constant Speed 6
1	1	1	Constant Speed 7

**DI3,4,5**

Refer to DI1,2,3.



**DI4,5,6**

Refer to DI1,2,3.

**DI3,4,5,6**

15 Constant Speeds (1 ... 15) are selected with four digital inputs.

*Table 6-6 Constant Speed selection with digital inputs DI3,4,5,6.*

DI3	DI4	DI5	DI6	Function
0	0	0	0	No Const. Speed
1	0	0	0	Constant Speed 1
0	1	0	0	Constant Speed 2
1	1	0	0	Constant Speed 3
0	0	1	0	Constant Speed 4
1	0	1	0	Constant Speed 5
0	1	1	0	Constant Speed 6
1	1	1	0	Constant Speed 7
0	0	0	1	Constant Speed 8
1	0	0	1	Constant Speed 9
0	1	0	1	Constant Speed 10
1	1	0	1	Constant Speed 11
0	0	1	1	Constant Speed 12
1	0	1	1	Constant Speed 13
0	1	1	1	Constant Speed 14
1	1	1	1	Constant Speed 15

**DI7(SPEED1); DI8 (SPEED2); DI9(SPEED3); DI10 (SPEED4);  
DI11(SPEED5); DI12 (SPEED6); DI7,8; DI9,10; DI11,12**

For the connection of digital inputs DI7 to DI12, see *Group 98 Option Modules*. For the function descriptions, see the corresponding selections implemented using DI1 to DI6.

**Group 13 Analogue Inputs**

These parameter values can be altered with the ACS 600 running. The Range/Unit column in Table 6-7 below shows the allowable parameter values. The text following the table explains the parameters in detail.

Table 6-7 Group 13.

Parameter	Range/Unit	Description
1 MINIMUM AI1	0 V; 2 V; TUNED VALUE; TUNE	Minimum value of AI1. Value to correspond to minimum reference.
2 MAXIMUM AI1	10 V; TUNED VALUE; TUNE	Maximum value of AI1. Value to correspond to maximum reference.
3 SCALE AI1	0 ... 100.0 %	Scaling factor for AI1.
4 FILTER AI1	0 ... 10 s	Filter time constant for AI1.
5 INVERT AI1	NO; YES	Analogue input signal 1 inversion.
6 MINIMUM AI2	0 mA; 4 mA; TUNED VALUE; TUNE	Minimum value of AI2. Value to correspond to minimum reference.
7 MAXIMUM AI2	20 mA; TUNED VALUE; TUNE	Maximum value of AI2. Value to correspond to maximum reference.
8 SCALE AI2	See the corresponding parameters for AI1.	
9 FILTER AI2		
10 INVERT AI2		
11 MINIMUM AI3		
12 MAXIMUM AI3		
13 SCALE AI3		
14 FILTER AI3		
15 INVERT AI3		
16 MINIMUM AI5		
17 MAXIMUM AI5		
18 SCALE AI5		
19 FILTER AI5		
20 INVERT AI5		
21 MINIMUM AI6		
22 MAXIMUM AI6		
23 SCALE AI6		
24 FILTER AI6		
25 INVERT AI6		

**13.01 MINIMUM AI1 0 V; 2 V; TUNED VALUE; TUNE**

This parameter sets the minimum value of the signal to be applied to AI1. If AI1 is selected as the signal source for external reference 1 (Par. 11.03) or external reference 2 (Par. 11.06), this value will correspond to the reference defined by Parameter 11.04 EXT REF1 MINIMUM or 11.07 EXT REF2 MINIMUM. Typical minimum values are 0 V or 2 V.

To tune the minimum value according to the analogue input signal, press the **ENTER** key, select TUNE, apply the minimum analogue input signal and press **ENTER** again. The value is set as the minimum. The readable range in tuning is 0 V to 10 V. The text TUNED VALUE is displayed after the TUNE operation.

The ACS 600 has a “living zero” function which allows the protection and supervision circuitry to detect a loss of control signal. To enable this feature, the minimum input signal must be set higher than 0.5 V and Parameter 30.01 AI<MIN FUNCTION must be set accordingly.

**13.02 MAXIMUM AI1 10 V; TUNED VALUE; TUNE**

This parameter sets the maximum value of the signal to be applied to AI1. If AI1 is selected as the signal source for external reference 1 (Par. 11.03) or external reference 2 (Par. 11.06), this value will correspond to the reference defined by Parameter 11.05 EXT REF1 MAXIMUM or 11.08 EXT REF2 MAXIMUM. A typical maximum value is 10 V.

To tune the maximum value according to the analogue input signal, press the **ENTER** key, select TUNE, apply the maximum analogue input signal and press **ENTER** again. The value is set as the maximum. The readable range in tuning is 0 V to 10 V. The text TUNED VALUE is displayed after TUNE operation.

**13.03 SCALE AI1** Scaling factor for analogue input AI1 signal. See Figure 6-5.

**13.04 FILTER AI1** Filter time constant for analogue input AI1. As the analogue input value changes, 63 % of the change takes place within the time specified by this parameter.

**Note:** Even if you select 0 s as the minimum value, the signal is still filtered with a time constant of 10 ms due to the signal interface hardware. This cannot be changed by any parameters.

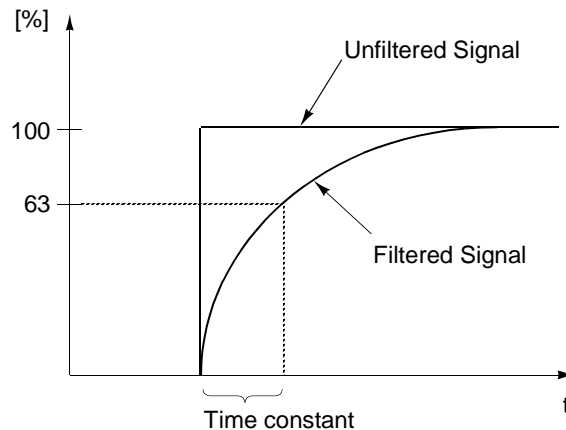

Figure 6-4 Filter time constant for analogue input AI1.

**13.05 INVERT AI1 NO; YES**

If this parameter is set to YES, the maximum value of the analogue input signal corresponds to minimum reference and the minimum value of the analogue input signal corresponds to maximum reference.

**13.06 MINIMUM AI2 0 mA; 4 mA; TUNED VALUE; TUNE**

This parameter sets the minimum value of the signal to be applied to analogue input AI2. If AI2 is selected as the signal source for external reference 1 (Par. 11.03) or external reference 2 (Par. 11.06), this value will correspond to the reference set by Parameter 11.04 EXT REF1 MINIMUM or 11.07 EXT REF2 MINIMUM. Typical minimum values are 0 mA or 4 mA.

To tune the minimum value according to the analogue input signal, press the **ENTER** key, select TUNE, apply the minimum analogue input signal and press **ENTER** again. The value is set as the minimum. The readable range in tuning is 0 mA to 20 mA. The text TUNED VALUE is displayed after the TUNE operation.

The ACS 600 has a “living zero” function which allows the protection and supervision circuitry to detect a loss of signal. To enable this feature, the minimum input signal must be greater than 1 mA.

**13.07 MAXIMUM AI2 20 mA; TUNED VALUE; TUNE**

This parameter sets the maximum value of the signal to be applied to AI2. If AI2 is selected as the signal source for external reference 1 (Parameter 11.03 EXT REF1 SELECT (O)) or external reference 2 (Parameter 11.06 EXT REF2 SELECT (O)), this value will correspond to the reference defined by Parameter 11.05 EXT REF1 MAXIMUM or 11.08 EXT REF2 MAXIMUM. A typical maximum value is 20 mA.

To tune the maximum value according to the analogue input signal, press the **ENTER** key, select TUNE, apply the maximum analogue input signal and press **ENTER** again. The values is set as the

maximum. The readable range in tuning is 0 mA to 20 mA. The text TUNED VALUE is displayed after TUNE operation.

- 13.08 SCALE AI2 Refer to Parameter 13.03 SCALE AI1.
- 13.09 FILTER AI2 Refer to Parameter 13.04 FILTER AI1.
- 13.10 INVERT AI2 Refer to Parameter 13.05 INVERT AI1.
- 13.11 MINIMUM AI3 Refer to Parameter 13.06 MINIMUM AI2.
- 13.12 MAXIMUM AI3 Refer to Parameter 13.07 MAXIMUM AI2.
- 13.13 SCALE AI3 Refer to Parameter 13.03 SCALE AI1.
- 13.14 FILTER AI3 Refer to Parameter 13.04 FILTER AI1.
- 13.15 INVERT AI3 Refer to Parameter 13.05 INVERT AI1.
- 13.16 MINIMUM AI5 Refer to Parameter 13.06 MINIMUM AI2.
- 13.17 MAXIMUM AI5 Refer to Parameter 13.07 MAXIMUM AI2.
- 13.18 SCALE AI5 Refer to Parameter 13.03 SCALE AI1.
- 13.19 FILTER AI5 Refer to Parameter 13.04 FILTER AI1.
- 13.20 INVERT AI5 Refer to Parameter 13.05 INVERT AI1.
- 13.21 MINIMUM AI6 Refer to Parameter 13.06 MINIMUM AI2.
- 13.22 MAXIMUM AI6 Refer to Parameter 13.07 MAXIMUM AI2.
- 13.23 SCALE AI6 Refer to Parameter 13.03 SCALE AI1.
- 13.24 FILTER AI6 Refer to Parameter 13.04 FILTER AI1.
- 13.25 INVERT AI6 Refer to Parameter 13.05 INVERT AI1.

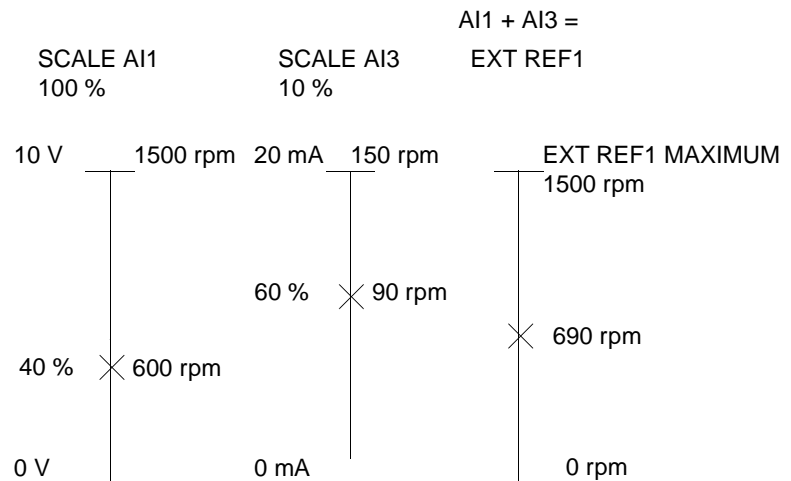

*Figure 6-5 Example of scaling of analogue inputs. External reference 1 has been selected by Parameter 11.03 EXT REF1 SELECT (0) as AI1 + AI3 and the maximum value for it (1500 rpm) by Parameter 11.05 EXT REF1 MAXIMUM. The scale for analogue input AI1 is set to 100 % by Parameter 13.03 SCALE AI1. The scale for analogue input AI3 is set to 10 % by Parameter 13.13 SCALE AI3.*

**Group 14 Relay Outputs**

These parameter values can only be altered when the ACS 600 is stopped. The text following Table 6-8 below explains the parameters in detail.

Table 6-8 Group 14.

Parameter	Range/Unit	Description
1 RELAY RO1 OUTPUT	Refer to the text below for the available selections.	Relay output 1 content.
2 RELAY RO2 OUTPUT		Relay output 2 content.
3 RELAY RO3 OUTPUT		Relay output 3 content.
4 RO1 TON DELAY	0.0 to 3600.0 s	Operation delay of the relay
5 RO1 TOFF DELAY	0.0 to 3600.0 s	Release delay of the relay
6 RO2 TON DELAY	0.0 to 3600.0 s	Operation delay of the relay
7 RO2 TOFF DELAY	0.0 to 3600.0 s	Release delay of the relay
8 RO3 TON DELAY	0.0 to 3600.0 s	Operation delay of the relay
9 RO3 TOFF DELAY	0.0 to 3600.0 s	Release delay of the relay
10 NDIO MOD1 RO1	READY; RUNNING; FAULT; WARNING; REF 2 SEL; AT SPEED; POINTER1 (or POINTER2 or POINTER3)	Drive status indicated by a relay output of the optional Digital I/O Extension Module (NDIO).
11 NDIO MOD1 RO2		
12 NDIO MOD2 RO1		
13 NDIO MOD2 RO2		
14 NDIO MOD3 RO1		
15 NDIO MOD3 RO2		

**14.01 RELAY RO1 OUTPUT**

This parameter allows you to select which information is indicated with relay output 1.

**NOT USED**

**READY**

The ACS 600 is ready to function. The relay is energised unless no run enable signal is present or a fault exists.

**RUNNING**

The ACS 600 has been started, run enable signal is active, and no active faults exist.

**FAULT**

A fault has occurred. See *Chapter 7 – Fault Tracing* for more details.

**FAULT (-1)**

Relay energised when power is applied, and de-energised upon a fault trip.

**FAULT(RST)**

The ACS 600 is in a fault condition, but will reset after the programmed autoreset delay (refer to Parameter 31.03 DELAY TIME).

**STALL WARN**

Stall alarm has been activated (refer to Parameter 30.10 STALL FUNCTION).

**STALL FLT**

Stall protection has tripped (refer to Parameter 30.10 STALL FUNCTION).

**MOT TEMP WRN**

Motor temperature has exceeded the warning level.

**MOT TEMP FLT**

Motor thermal protection has tripped.

**ACS TEMP WRN**

The ACS 600 temperature has exceeded the warning level 115 °C (239 °F).

**ACS TEMP FLT**

The ACS 600 overheat protection has tripped. The tripping level is 125 °C (257 °F).

**FAULT/WARN**

Any fault or warning has occurred.

**WARNING**

Any warning has occurred.

**REVERSED**

Motor rotates in reverse direction.

**EXT CTRL**

External control is selected.

**REF 2 SEL**

Reference 2 is selected.

**CONST SPEED**

A Constant Speed (1 ... 15) is selected.

**DC OVERVOLT**

The intermediate circuit DC voltage has exceeded the overvoltage limit.

**DC UNDERVOL**

The intermediate circuit DC voltage has fallen below the undervoltage limit.

**SPEED 1 LIM**

Output speed has exceeded or fallen below the supervision limit 1. Refer to Parameter 32.01 SPEED1 FUNCTION and Parameter 32.02 SPEED1 LIMIT.

**SPEED 2 LIM**

Output speed has exceeded or fallen below the supervision limit 2. Refer to Parameter 32.03 SPEED2 FUNCTION and Parameter 32.04 SPEED2 LIMIT.

**CURRENT LIM**

Motor current has exceeded or fallen below the set current supervision limit. Refer to Parameter 32.05 CURRENT FUNCTION and Parameter 32.06 CURRENT LIMIT.

**REF 1 LIM**

Reference 1 has exceeded or fallen below the set supervision limit. Refer to Parameter 32.11 REF1 FUNCTION and Parameter 32.12 REF1 LIMIT.

**REF 2 LIM**

Reference 2 has exceeded or fallen below the set supervision limit. Refer to Parameter 32.13 REF2 FUNCTION and Parameter 32.14 REF2 LIMIT.

**TORQUE 1 LIM**

The motor torque has exceeded or fallen below the set supervision limit. Refer to Parameter 32.07 TORQUE1 FUNCTION and Parameter 32.08 TORQUE1 LIMIT.

**TORQUE 2 LIM**

The motor torque has exceeded or fallen below the set supervision limit. Refer to Parameter 32.09 TORQUE2 FUNCTION and Parameter 32.10 TORQUE2 LIMIT.

**STARTED**

The ACS 600 has received a Start command.

**LOSS OF REF**

The reference has been lost.

**AT SPEED**

The actual value has reached the reference value. The speed error is max. 10 % of the nominal speed in the speed control mode.

**ACT1 LIM**

PID controller actual value 1 has exceeded or fallen below the set supervision limit. Refer to Parameter 32.15 ACT1 FUNCTION and Parameter 32.16 ACT1 LIMIT.

**ACT2 LIM**

PID controller actual value 2 has exceeded or fallen below the set supervision limit. Refer to Parameter 32.17 ACT2 FUNCTION and Parameter 32.18 ACT2 LIMIT.

**COMM. MODULE**

The relay is controlled by fieldbus reference REF3. See *Appendix C – Fieldbus Control*.

**POINTER1**

The relay output is controlled by a status bit selected using Parameters 45.01 POINTER1 GRP+IND and 45.02 POINTER1 BIT.

**BRAKE CTRL**

The relay output is controlled by a brake control function. See *Group 42 Brake Control*.



**14.02 RELAY RO2 OUTPUT**

Refer to Parameter 14.01 RELAY RO1 OUTPUT. Difference:

- POINTER1 is replaced with POINTER2.  
The relay is controlled by a status bit selected using Parameters 45.03 POINTER2 GRP+IND and 45.04 POINTER2 BIT.

**14.03 RELAY RO3 OUTPUT**

Refer to Parameter 14.01 RELAY RO1 OUTPUT. Differences:

- ACT 1 LIM and ACT 2 LIM indications cannot be selected for RO3.
- POINTER1 is replaced with POINTER3.  
The relay is controlled by a status bit selected using Parameters 45.05 POINTER3 GRP+IND and 45.06 POINTER3 BIT.
- MAGN READY can be selected for RO3 only.  
The motor is magnetised and ready to give nominal torque (nominal magnetising of the motor has been reached).
- USER 2 SEL can be selected for RO3 only.  
The User Macro 2 has been loaded.

**14.04 RO1 TON DELAY**

Sets an operation delay for relay output RO1.

**0.0 s to 3600.0 s**

Default value is 0.0 s.

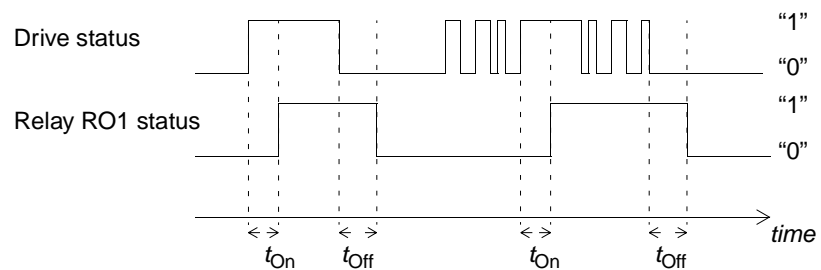

$t_{On}$  Operation delay for relay output RO1 (14.04 RO1 TON DELAY)

$t_{Off}$  Release delay for relay output RO1 (14.05 RO1 TOFF DELAY)

**14.05 RO1 TOFF DELAY**

Sets the release delay for relay output RO1. See Parameter 14.04 RO1 TON DELAY for more information.

**14.06 RO2 TON DELAY**

Sets the operation delay for relay output RO2. See Parameter 14.04 RO1 TON DELAY for more information.

**14.07 RO2 TOFF DELAY**

Sets the release delay for relay output RO2. See Parameter 14.04 RO1 TON DELAY for more information.

**14.08 RO3 TON DELAY**

Sets the operation delay for relay output RO3. See Parameter 14.04 RO1 TON DELAY for more information.

**14.09 RO3 TOFF DELAY**

Sets the release delay for relay output RO3. See Parameter 14.04 RO1 TON DELAY for more information.

- 14.10 NDIO MOD1 RO1** Selects the drive status that is indicated by relay output RO1 of the optional Digital I/O Extension Module no. 1 (see Parameter 98.03 DI/O EXT MODULE 1).
- READY; RUNNING; FAULT; WARNING; REF 2 SEL; AT SPEED**  
READY is the default value. See Parameter 14.01 RELAY RO1 OUTPUT for more information on the selections.
- POINTER1**  
The relay output is controlled by a status bit selected using Parameters 45.01 POINTER1 GRP+IND and 45.02 POINTER1 BIT.
- 14.11 NDIO MOD1 RO2** Selects the drive status that is indicated by relay output RO2 of the optional Digital I/O Extension Module no. 1 (see Parameter 98.03 DI/O EXT MODULE 1).
- READY; RUNNING; FAULT; WARNING; REF 2 SEL; AT SPEED**  
RUNNING is the default value. See Parameter 14.01 RELAY RO1 OUTPUT for more information on the selections.
- POINTER2**  
The relay is controlled by a status bit selected using Parameters 45.03 POINTER2 GRP+IND and 45.04 POINTER2 BIT.
- 14.12 NDIO MOD2 RO1** Selects the drive status that is indicated by relay output RO1 of the optional Digital I/O Extension Module no. 2 (see Parameter 98.04 DI/O EXT MODULE 2).
- READY; RUNNING; FAULT; WARNING; REF 2 SEL; AT SPEED**  
FAULT is the default value. See Parameter 14.01 RELAY RO1 OUTPUT for more information on the selections.
- POINTER3**  
The relay is controlled by a status bit selected using Parameters 45.05 POINTER3 GRP+IND and 45.06 POINTER3 BIT.
- 14.13 NDIO MOD2 RO2** Selects the drive status that is indicated by relay output RO2 of the optional Digital I/O Extension Module no. 2 (see Parameter 98.04 DI/O EXT MODULE 2).
- READY; RUNNING; FAULT; WARNING; REF 2 SEL; AT SPEED**  
WARNING is the default value. See Parameter 14.01 RELAY RO1 OUTPUT for more information on the selections.
- POINTER4**  
The relay is controlled by a status bit selected using Parameters 45.07 POINTER4 GRP+IND and 45.08 POINTER4 BIT.
- 14.14 NDIO MOD3 RO1** Selects the drive status that is indicated by relay output RO1 of the optional Digital I/O Extension Module no. 3 (see Parameter 98.05 DI/O EXT MODULE 3).
- READY; RUNNING; FAULT; WARNING; REF 2 SEL; AT SPEED**  
REF 2 SEL is the default value. See Parameter 14.01 RELAY RO1 OUTPUT for more information on the selections.

**POINTER5**

The relay is controlled by a status bit selected using Parameters 45.09 POINTER5 GRP+IND and 45.10 POINTER5 BIT.

*14.15 NDIO MOD3 RO2*

Selects the drive status that is indicated by relay output RO2 of the optional Digital I/O Extension Module no. 3 (see Parameter 98.05 DI/O EXT MODULE 3).

**READY; RUNNING; FAULT; WARNING; REF 2 SEL; AT SPEED**

AT SPEED is the default value. See Parameter 14.01 RELAY RO1 OUTPUT for more information on the selections.

**POINTER6**

The relay is controlled by a status bit selected using Parameters 45.11 POINTER6 GRP+IND and 45.12 POINTER6 BIT.

**Group 15 Analogue Outputs**

These parameter values can be altered with the ACS 600 running, except those marked with (O). The Range/Unit column in Table 6-9 below shows the allowable parameter values. The text following the table explains the parameters in detail.

Table 6-9 Group 15.

Parameter	Range/Unit	Description
1 ANALOGUE OUTPUT 1 (O)	Refer to the text below for the available selections.	Analogue output 1 content.
2 INVERT AO1	NO; YES	Analogue output signal 1 inversion.
3 MINIMUM AO1	0 mA; 4 mA	Analogue output signal 1 minimum.
4 FILTER AO1	0.00 ... 10.00 s	Filter time constant for AO1.
5 SCALE AO1	10 ... 1000 %	Analogue output signal 1 scaling factor.
6 ANALOGUE OUTPUT 2 (O)	Refer to the text below for the available selections.	Analogue output 2 content.
7 INVERT AO2	NO; YES	Analogue output signal 2 inversion.
8 MINIMUM AO2	0 mA; 4 mA	Analogue output signal 2 minimum.
9 FILTER AO2	0.00 ... 10.00 s	Filter time constant for AO2.
10 SCALE AO2	10 ... 1000 %	Analogue output signal 2 scaling factor.

**15.01 ANALOGUE OUTPUT1 (O)**

This parameter allows you to select which output signal is connected to analogue output AO1 (current signal). The following list shows the full scale value with Parameters 15.05 SCALE AO1 and 15.10 SCALE AO2 set to 100 %.

**NOT USED****P SPEED**

Value of a process quantity derived from the motor speed. Refer to *Group 34 Process Variable* for scaling and unit selection (%; m/s; rpm). The updating interval is 100 ms.

**SPEED**

Motor speed. 20 mA = motor nominal speed. The updating interval is 24 ms.

**FREQUENCY**

Output frequency. 20 mA = motor nominal frequency. The updating interval is 24 ms.

**CURRENT**

Output current. 20 mA = motor nominal current. The updating interval is 24 ms.

**TORQUE**

Motor torque. 20 mA = 100 % of motor nominal rating. The updating interval is 24 ms.

**POWER**

Motor power. 20 mA = 100 % of motor nominal rating. The updating interval is 100 ms.

**DC BUS VOLT**

DC bus voltage. 20 mA = 100 % of the reference value.

The reference value is 540 V d.c. ( $=1.35 \cdot 400$  V) for the ACS 600 with 380 ... 415 V a.c. mains voltage rating and 675 V d.c. ( $1.35 \cdot 500$  V) for the ACS 600 with 380 ... 500 V a.c. mains voltage rating. The updating interval is 24 ms.

**OUTPUT VOLT**

Motor voltage. 20 mA = motor rated voltage. The updating interval is 100 ms.

**APPL OUTPUT**

The reference which is given as output from the application. For example, if the PID Control macro is in use, this is the output of the process PID controller. The updating interval is 24 ms.

**REFERENCE**

Active reference that the ACS 600 is currently following. 20 mA = 100 % of the active reference. The updating interval is 24 ms.

**CONTROL DEV**

The difference between the reference and the actual value of the Process PID Controller. 0/4 mA = -100 %, 10/12 mA = 0 %, 20 mA = 100 %. The updating interval is 24 ms.

**ACTUAL 1**

Actual value 1 of the process PID controller. 20 mA = value of Parameter 40.10 ACT1 MAXIMUM. The updating interval is 24 ms.

**ACTUAL 2**

Actual value 2 of the process PID controller. 20 mA = value of Parameter 40.12 ACT2 MAXIMUM. The updating interval is 24 ms.

**COMM. MODULE**

The value is read from fieldbus reference REF4. See *Appendix C – Fieldbus Control*.

**M1 TEMP MEAS**

Analogue output is a current source in a motor temperature measuring circuit. Depending on the sensor type, the output is 9.1 mA (Pt 100) or

1.6 mA (PTC). For more information, see Parameter 35.01 MOT1 TEMP AI1 SEL.

If this value is selected, the settings of Parameters 15.02 INVERT AO1 to 15.05 SCALE AO1 are not effective.

15.02 INVERT AO1 If you select YES, the analogue output AO1 signal is inverted.

15.03 MINIMUM AO1 The minimum value of the analogue output signal can be set to either 0 mA or 4 mA.

15.04 FILTER AO1 Filter time constant for analogue output AO1.

As the analogue output value changes, 63 % of the change takes place within the time period specified by this parameter (See Figure 6-4).

**Note:** Even if you select 0 s as the minimum value, the signal is still filtered with a time constant of 10 ms due to the signal interface hardware. This cannot be changed by any parameters.

15.05 SCALE AO1 This parameter is the scaling factor for the analogue output AO1 signal. If the selected value is 100 %, the nominal value of the output signal corresponds to 20 mA. If the maximum is less than full scale, increase the value of this parameter.

**Example:** The nominal motor current is 7.5 A and the measured maximum current at maximum load is 5 A. The motor current 0 to 5 A is read as 0 to 20 mA analogue signal through AO1.

1. AO1 is set to CURRENT with Parameter 15.01 ANALOGUE OUTPUT1 (O).
2. AO1 minimum is set to 0 mA with Parameter 15.03 MINIMUM AO1.
3. The measured maximum motor current is scaled to correspond to 20 mA analogue output signal: The reference value of the output signal CURRENT is the motor nominal current i.e. 7.5 A (see Parameter 15.01 ANALOGUE OUTPUT1 (O)). With 100 % scaling, the reference value corresponds to full scale output signal 20 mA. To make the measured maximum motor current correspond to 20 mA, it should be scaled equal to the reference value before it is converted to analogue output signal.

$$k \cdot 5 \text{ A} = 7.5 \text{ A} \Rightarrow k = 1.5 = 150 \%$$

Thus the scaling factor is set to 150 %.

15.06 ANALOGUE OUTPUT2 (O) Refer to Parameter 15.01 ANALOGUE OUTPUT1 (O).

**Exceptions:**

- If COMM. MODULE is selected, the value is read from fieldbus reference REF 5. See *Appendix C – Fieldbus Control*.
- Selection M1 TEMP MEAS is not available.

15.07 INVERT AO2 Refer to Parameter 15.02 INVERT AO1.

- 15.08 *MINIMUM AO2* Refer to Parameter 15.03 *MINIMUM AO1*.
- 15.09 *FILTER AO2* Refer to Parameter 15.04 *FILTER AO1*.
- 15.10 *SCALE AO2* Refer to Parameter 15.05 *SCALE AO1*.

**Group 16 System Ctr  
Inputs**

These parameter values can only be altered with the ACS 600 stopped. The Range/Unit column in Table 6-10 below shows the allowable parameter values. The text following the table explains the parameters in detail.

Table 6-10 Group 16.

Parameter	Range/Unit	Description
1 RUN ENABLE	YES; DI1; ...; DI12; COMM. MODULE	Run enable input.
2 PARAMETER LOCK	OPEN; LOCKED;	Parameter lock input.
3 PASS CODE	0 ... 30000	Parameter lock pass code.
4 FAULT RESET SEL	NOT SEL; DI1; ... ;DI6; ON STOP; COMM. MODULE; DI7; ... ; DI12	Fault reset input.
5 USER MACRO IO CHG	NOT SEL; DI1; ... ; DI12	Restores parameters to user macro setting values.
6 LOCAL LOCK	OFF; ON	Disables local control (Panel)
7 PARAM SAVE	SAVE..; DONE	Parameter saving to the permanent memory

**16.01 RUN ENABLE**

This parameter selects the source of the run enable signal.

Indication of missing Run Enable signal is shown on the first row of the Control Panel display (see *Chapter 2 – Overview of ACS 600 Programming and the CDP 312 Control Panel*).

**YES**

Run enable signal is active. The ACS 600 is ready to start without an external run enable signal.

**DI1 ... DI12**

To activate the Run Enable signal, the selected digital input must be connected to +24 V DC. If the voltage drops to 0 V DC, the ACS 600 will stop and will not start until the run enable signal resumes. The drive stop mode is selected with Parameter 21.07 RUN ENABLE FUNC.

For the connection of DI7 to DI12 see *Group 98 Option Modules*.

**COMM. MODULE**

The signal is given through Fieldbus Control Word. See *Appendix C – Fieldbus Control*.

**16.02 PARAMETER  
LOCK**

This parameter selects the state of the Parameter Lock. With Parameter Lock you can inhibit unauthorised parameter changes.

**OPEN**

Parameter Lock is open. Parameters can be altered.



**LOCKED**

Parameter Lock is closed from the Control Panel. Parameters cannot be altered. The Parameter Lock can be opened only by entering the valid code at Parameter 16.03 PASS CODE.

**16.03 PASS CODE**

This parameter selects the Pass Code for the Parameter Lock. The default value of this parameter is 0. In order to open the Parameter Lock change the value to 358. After the Parameter Lock is opened the value is automatically changed back to 0.

**16.04 FAULT RESET SEL****NOT SEL**

If you select NOT SEL, fault reset is executed from the Control Panel keypad only.

**DI1 ... DI12**

If a digital input is selected, fault reset is executed through the digital input, or from the Control Panel:

- Control Panel is in remote mode: Reset is activated by a rising (positive) edge of the digital input signal i.e. by closing the normally open contact connecting 24 VDC to the digital input terminal.
- Control Panel is in local mode: Reset is activated by the Control Panel reset key.

For the connection of DI7 to DI12, see *Group 98 Option Modules*.

**ON STOP**

Fault reset is executed along with the stop signal received through a digital input. Reset can be given from the Control Panel also.

**COMM. MODULE**

The signal is given through fieldbus Control Word. See *Appendix C – Fieldbus Control*. Reset can be given from the Control Panel also.

**16.05 USER MACRO IO  
CHG****NOT SEL; DI1 ... DI12**

This parameter enables the selection of the desired User Macro via a digital input in the following way:

When the state of the specified digital input changes from high to low User Macro 1 is loaded. When the state of the specified digital input changes from low to high User Macro 2 is loaded.

The User Macro used can be changed via a digital input only when the drive is stopped. During the change of the Macro the drive will not start.

The value of this parameter is not included in the User Macro. The setting once made remains despite of the User Macro change.

User Macro 2 selection can be supervised via relay output 3. See Parameter 14.03 RELAY RO3 OUTPUT for more information.

---

**Note:** Always redo the User Macro save by Parameter 99.02 APPLICATION MACRO after changing parameter settings or reperforming the motor identification. If Parameter 16.05 USER

MACRO IO CHG is pointing to digital input, the last settings saved by the user are loaded into use whenever the power is switched off and on again, or macro is changed. Any unsaved changes will be lost.

---

For the connection of DI7 to DI12, see *Group 98 Option Modules*.

#### 16.06 LOCAL LOCK

##### **OFF**

No local lock in use.

##### **ON**

Disables entering to local control mode (LOC/REM key of the Panel).

---



**WARNING:** Before activating this function it must be ensured that the Control Panel is not needed for stopping the drive.

---

#### 16.07 PARAM SAVE

##### **SAVE..; DONE**

Selection SAVE saves parameter values to the permanent memory.

---

**Note:** A new parameter value of a standard macro is saved automatically when changed from the Panel but not when altered through a fieldbus connection.

---

**Group 20 Limits** These parameter values can be altered with the ACS 600 running. The Range/Unit column in Table 6-11 below shows the allowable parameter values. The text following the table explains the parameters in detail.

Table 6-11 Group 20.

Parameter	Range/Unit	Description
1 MINIMUM SPEED	-18000/(number of pole pairs)... 20.02 MAXIMUM SPEED	Operating range minimum speed. Cannot be used in the SCALAR mode.
2 MAXIMUM SPEED	20.01 MINIMUM SPEED ... 18000/(number of pole pairs)	Operating range maximum speed. Cannot be used in the SCALAR mode.
3 MAXIMUM CURRENT	0 % $I_{hd}$ ... 200 % $I_{hd}$	Maximum output current.
4 MAXIMUM TORQUE	0.0 % ... 600.0 %	Maximum torque. Cannot be used in the SCALAR mode.
5 OVERVOLTAGE CTRL	YES; NO	DC overvoltage controller
6 UNDERVOLTAGE CTRL	YES; NO	DC undervoltage controller
7 MINIMUM FREQ	-300 Hz ... 50 Hz	Operating range minimum frequency. Visible in the SCALAR mode only.
8 MAXIMUM FREQ	-50 ... 300 Hz	Operating range maximum frequency. Visible in the SCALAR mode only.
9 MIN TORQ SELECTOR	-MAX TORQ; SET MIN TORQ	Minimum torque limit selector. Cannot be used in the SCALAR mode.
10 SET MIN TORQUE	-600.0 % ... 0.0 %	Minimum torque value, when Parameter 20.09 MIN TORQ SELECTOR is SET MIN TORQ. Cannot be used in the SCALAR mode.
11 P MOTORING LIMIT	0%...600%	Limit for the maximum power from inverter to motor
12 P GENERATING LIMIT	-600% .. 0%	Limit for the maximum power from motor to inverter

20.01 MINIMUM SPEED

Represents the minimum speed. The default value depends on the number of motor pole pairs and it is either -750, -1000, -1500 or -3000. When the value is positive the motor will not run in the reverse direction.

This limit cannot be set in the SCALAR control mode.



---

**Note:** The speed limits in *Group 20 Limits* are linked to the setting of 99.08 MOTOR NOM SPEED. If value of Parameter 99.08 MOTOR NOM SPEED is changed, the speed limit settings change automatically as well.

---

20.02 MAXIMUM SPEED

Represents the maximum speed. The default value depends on the selected motor and it is either 750, 1000, 1500 or 3000.

This limit cannot be set in the SCALAR control mode.



---

**Note:** The speed limits in *Group 20 Limits* are linked to the setting of 99.08 MOTOR NOM SPEED. If value of Parameter 99.08 MOTOR NOM SPEED is changed, the speed limit settings change automatically as well.

---

20.03 MAXIMUM  
CURRENT

The maximum output current that the ACS 600 will supply to the motor. The default value is 200 %  $I_{2hd}$  e.g. 200 percentage of the heavy-duty use output current of the ACS 600.

20.04 MAXIMUM  
TORQUE

This setting defines the momentarily allowed maximum torque of the motor in the forward direction. The motor control software of the ACS 600 limits the setting range of the maximum torque according to the inverter and motor data. The default value is 300 % of the nominal torque of the motor.

This limit cannot be set in the SCALAR control mode.

20.05 OVERVOLTAGE  
CTRL

Selection **NO** deactivates the overvoltage controller.

Fast braking of a high inertia load causes the DC bus voltage to rise to the overvoltage control limit. To prevent the DC voltage from exceeding the limit, the overvoltage controller automatically decreases the braking torque.

**CAUTION!** If a braking chopper and a braking resistor are connected to the ACS 600, this parameter value must be set to OFF to ensure proper operation of the chopper.

20.06 UNDERVOLTAGE  
CTRL

Selection **NO** deactivates the undervoltage controller.

If the DC bus voltage drops due to loss of input power, the undervoltage controller will decrease the motor speed in order to keep the DC bus voltage above the lower limit. By decreasing the motor speed, the inertia of the load will cause regeneration back into the ACS 600, keeping the DC bus charged, and preventing an undervoltage trip.

	This will increase power loss ride through on systems with a high inertia, such as a centrifuge or fan.
<i>20.07 MINIMUM FREQ</i>	This limit can be set in the SCALAR control mode only. When the value is positive the motor will not run in the reverse direction.
<i>20.08 MAXIMUM FREQ</i>	This limit can be set in the SCALAR control mode only.
<i>20.09 MIN TORQ SELECTOR</i>	Parameter defines the allowed minimum torque i.e. the allowed torque in reverse (negative) rotation direction.  This parameter cannot be set in the SCALAR control mode.  <b>-MAX TORQ</b>  Minimum torque limit is equal to the inverted maximum limit (20.04 MAXIMUM TORQUE).  <b>SET MIN TORQ</b>  Minimum torque limit is defined with Parameter 20.10 SET MIN TORQUE.
<i>20.10 SET MIN TORQUE</i>	Parameter defines the allowed minimum torque of the motor when Parameter 20.09 MIN TORQ SELECTOR is set to value SET MIN TORQ.  This parameter cannot be set in the SCALAR control mode.  <b>-600 % ... 0%</b> Minimum torque limit in percent of the nominal motor torque. Default value is -300 %.
<i>20.11 P MOTORING LIMIT</i>	Parameter defines the allowed maximum power fed by the inverter to the motor.  <b>0% ... 600%</b> Maximum motoring power limit in percent of the motor nominal power. Default value is 300%.
<i>20.12 P GENERATING LIMIT</i>	Parameter defines the allowed maximum power fed by the motor to the inverter.  <b>-600% ... 0%</b> Maximum generating power limit in percent of the motor nominal power. Default value is -300%.

**Group 21 Start/Stop**

The parameter values marked with (O) cannot be altered with the ACS 600 running. The Range/Unit column in Table 6-12 below shows the allowable parameter values. The text following the table explains the parameters in detail.

Table 6-12 Group 21.

Parameter	Range/Unit	Description
1 START FUNCTION (O)	AUTO; DC MAGN; CNST DC MAGN	Start function selection.
2 CONST MAGN TIME (O)	30.0 ms ... 10000.0 ms	Time for pre-magnetising.
3 STOP FUNCTION	COAST; RAMP	Stop function selection.
4 DC HOLD	NO; YES	Enable DC Hold.
5 DC HOLD SPEED (O)	0 rpm ... 3000 rpm	Speed for DC Hold.
6 DC HOLD CURR (O)	0 % ... 100 %	Current for DC Hold.
07 RUN ENABLE FUNC	RAMP STOP; COAST STOP; OFF2 STOP; OFF3 STOP	Drive stop mode for the run enable function
8 SCALAR FLY START	NO; YES	Activation of the flying start feature in scalar control mode.

### 21.01 START FUNCTION (O)

**AUTOMATIC**

Automatic start is the default start function. This selection guarantees optimal motor start in most cases. It includes the flying start (starting to a rotating machine) and the automatic restart (stopped motor can be restarted immediately without waiting the motor flux to die away) functions.

The ACS 600 motor control identifies the flux as well as the mechanical state of the motor and starts the motor instantly under all conditions.

AUTOMATIC is always to be selected in the scalar control mode (see Parameter 99.04 MOTOR CTRL MODE) although no flying start or automatic restart is possible by default in scalar control. The flying start feature needs to be activated separately with Parameter 21.08 SCALAR FLY START.

**DC MAGN**

DC magnetising should be selected if high breakaway torque is required. The ACS 600 pre-magnetises the motor before the start. The pre-magnetising time is determined automatically, being typically 200 ms to 2 s depending on the motor size. This selection guarantees the highest possible break-away torque.

The starting to a rotating machine is not possible when DC magnetising is selected. DC magnetising cannot be selected in the scalar control mode (see Parameter 99.04 MOTOR CTRL MODE).

**CNST DC MAGN**

Constant DC magnetising should be selected instead of DC magnetising if constant pre-magnetising time is required (e.g. if the motor start must be simultaneous with a mechanical brake release). This selection also guarantees the highest possible break-away torque when the pre-magnetising time is set long enough. The pre-magnetising time is defined by Parameter 21.02 CONST MAGN TIME (O).



**WARNING!** The drive will start after the set magnetising time has passed although the motor magnetisation is not completed. In applications where a full breakaway torque is essential, ensure always that the constant magnetising time is long enough to allow generation of full magnetisation and torque.

21.02 CONST MAGN  
TIME (O)

The starting to a rotating machine is not possible when DC magnetising is selected. DC magnetising cannot be selected in the scalar control mode (see Parameter 99.04 MOTOR CTRL MODE).

Defines the magnetising time in the constant magnetising mode. After the start command the ACS 600 automatically pre-magnetises the motor the set time.

To ensure full magnetising, set the value the same as or higher than the rotor time constant. If not known, use the rule-of-thumb value given in table below:

Motor Rated Power	Constant Magnetising Time
< 10 kW	≥ 100 to 200 ms
10 to 200 kW	≥ 200 to 1000 ms
1200 to 1000 kW	≥ 1000 to 2000 ms

21.03 STOP FUNCTION

**COAST**

The ACS 600 stops supplying voltage immediately after a Stop command is received and the motor coasts to a stop.

**RAMP**

Ramp deceleration, as defined by the active deceleration time, Parameter 22.03 DECEL TIME 1 or Parameter 22.05 DECEL TIME 2.



**Warning:** If the brake control function is on, the application program uses ramp stop in spite of the selection COAST (see *Group 42 Brake Control*)

21.04 DC HOLD

If this parameter is set to YES, the DC Hold feature is enabled.

DC Hold is not possible in the SCALAR control mode.

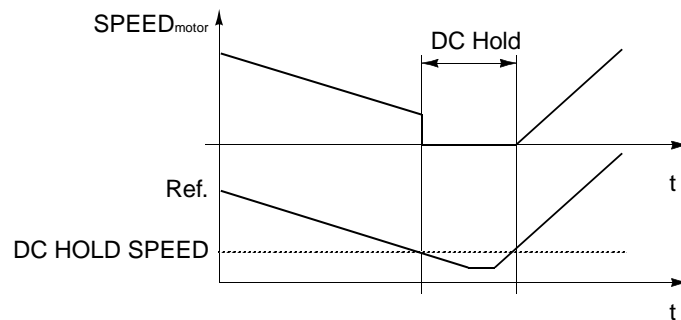

Figure 6-6 DC Hold.

When both reference and speed drop below Parameter 21.05 DC HOLD SPEED (O), the ACS 600 will stop generating sinusoidal current and inject DC into the motor. The current value is the current set by Parameter 21.06 DC HOLD CURR (O). When the reference speed rises above 21.05 DC HOLD SPEED (O), the DC will be removed and normal ACS 600 function resumed.

DC Hold has no effect if the Start signal is deactivated.

---

**Note:** Injecting DC current into the motor causes the motor to heat up. In applications where long DC Hold times are required, externally ventilated motors should be used. If the DC Hold period is long, the DC Hold cannot prevent the motor shaft from rotating if a constant load is applied to the motor.

---

21.05 DC HOLD SPEED  
(O)

Sets the speed limit for DC Hold.

21.06 DC HOLD CURR  
(O)

Sets the current applied to the motor when DC Hold is activated.

21.07 RUN ENABLE  
FUNC

Parameter selects which stop mode is applied when the run enable signal is switched off. The run enable signal is put into use by Parameter 16.01 RUN ENABLE.

The setting overrides the normal stop mode setting (Parameter 21.03 STOP FUNCTION) when the run enable signal is switched off.



**WARNING!** The drive will restart after the run enable signal restores (if the START signal is on).





---

**Warning:** If the brake control function is on, the application program uses ramp stop in spite of the selection COAST STOP (see *Group 42 Brake Control*).

---

#### **RAMP STOP**

This is the default value. The application program stops the drive along the deceleration ramp defined by Parameters in *Group 22 Accel/Decel*.

#### **COAST STOP**

The application program stops the drive by cutting off the motor power supply (the inverter IGBTs are blocked). The motor rotates freely to zero speed.

#### **OFF2 STOP**

The application program stops the drive by cutting off the motor power supply (the inverter IGBTs are blocked). The motor rotates freely to zero speed.

The drive will restart only when the run enable signal is on and the START signal is switched on (program receives a rising edge of the START signal).

#### **OFF3 STOP**

The application program stops the drive along the deceleration ramp defined by Parameter 22.07 EM STOP RAMP TIME.

The drive will restart only when the run enable is on and the START signal is switched on (program receives a rising edge of the START signal).

#### 21.08 SCALAR FLY START

This Parameter activates the flying start feature in the scalar control mode. See Parameters 21.01 START FUNCTION (O) and 99.04 MOTOR CTRL MODE.

#### **NO**

Flying start feature is not active. This is the default setting.

#### **YES**

Flying start feature is active.

**Group 22 Accel/Decel** These parameter values can be altered with the ACS 600 running, except those marked with (O). The Range/Unit column in Table 6-13 below shows the allowable parameter values. The text following the table explains the parameters in detail.

Table 6-13 Group 22.

Parameter	Range/Unit	Description
1 ACC/DEC 1/2 SEL (O)	ACC/DEC 1; ACC/DEC 2; DI1 ... DI12	Acceleration/Deceleration ramp selection.
2 ACCEL TIME 1	0.00 ... 1800.00 s	Time for speed 0 to max. speed (Acceleration ramp 1).
3 DECEL TIME 1	0.00 ... 1800.00 s	Time for max. speed to 0 speed (Deceleration ramp 1).
4 ACCEL TIME 2	0.00 ... 1800.00 s	Time for speed 0 to max. speed (Acceleration ramp 2).
5 DECEL TIME 2	0.00 ... 1800.00 s	Time for speed max. to 0 speed (Deceleration ramp 2).
6 ACC/DEC RAMP SHPE	0 ... 1000.00 s	Accel./Decel. ramp shape time.
7 EM STOP RAMP TIME	0.00 ... 2000.00 s	Emergency Stop ramp time.

**22.01 ACC/DEC 1/2 SEL (O)** This parameter selects the Acceleration/Deceleration Ramp pair that is used. The selection can be performed through digital inputs DI1 to DI12. 0 V DC = Acceleration ramp 1 and Deceleration ramp 1 are used; 24 V DC = Acceleration ramp 2 and Deceleration ramp 2 are used.

For the connection of DI7 to DI12, see *Group 98 Option Modules*.

**22.02 ACCEL TIME 1** The time required for the speed to change from 0 to the maximum speed. The maximum speed is defined with Parameter 20.02 MAXIMUM SPEED, or 20.01 MINIMUM SPEED if the absolute value of the minimum limit is greater than the maximum limit.

If the reference signal changes at a rate slower than the acceleration time, the motor speed will follow the reference signal. If the reference signal changes faster than the acceleration time, the rate at which the motor speeds up will be limited by this parameter.

If acceleration time is set too short, the ACS 600 will automatically prolong the acceleration not to exceed the maximum current limit (Parameter 20.03 MAXIMUM CURRENT).

**22.03 DECEL TIME 1** The time required for the speed to change from maximum to zero. The maximum speed is defined with Parameter 20.02 MAXIMUM SPEED, or 20.01 MINIMUM SPEED, if the absolute value of the minimum limit is greater than the maximum limit.

If the reference signal changes at a rate slower than the deceleration time, the motor speed will follow the reference signal. If the reference signal changes faster than the deceleration time, the rate at which the motor slows down will be limited by this parameter.

If deceleration time is set too short, the ACS 600 will automatically prolong the deceleration not to exceed the DC bus overvoltage limit. If there is any doubt about the deceleration time being too short, ensure that the DC overvoltage control is on (Parameter 20.05 OVERVOLTAGE CTRL).

If short deceleration time is needed for the high inertia application, the ACS 600 should be equipped with a braking chopper and a braking resistor. The excess energy generated during the braking is led by the chopper to the resistor and dissipated to prevent a DC voltage rise in the intermediate circuit. The chopper and the resistor are available for all ACS 600 types as optional add-on kits.

22.04 ACCEL TIME 2 Refer to Parameter 22.02 ACCEL TIME 1.

22.05 DECEL TIME 2 Refer to Parameter 22.03 DECEL TIME 1.

22.06 ACC/DEC RAMP SHPE This parameter allows you to select the shape of the acceleration/deceleration ramp.

**0 s**

Linear ramp. Suitable for drives requiring steady acceleration or deceleration and for slow ramps.

**0.100 ... 1000.00 s**

S-curve ramp. S-curve ramps are ideal for conveyors carrying fragile loads, or other applications where a smooth transition is required when changing from one speed to another. The S curve consists of symmetrical curves at both ends of the ramp and a linear part in between.

As a rule of thumb, a suitable relation between the ramp shape time and the acceleration ramp time is 1/5. Examples are given below.

Acc/Dec Ramp Time (Par. 22.02 to 05)	Ramp Shape Time (Par. 22.06)
1 s	0.2 s
5 s	1 s
15 s	3 s

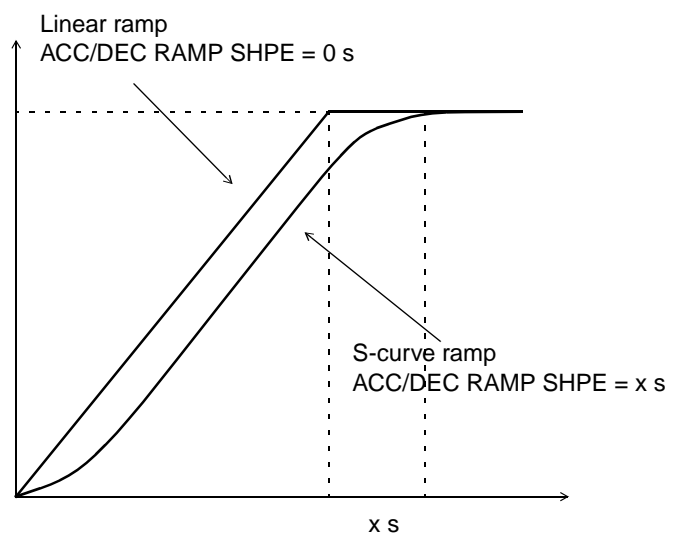

Figure 6-7 Acceleration and deceleration ramp shapes.

**22.07 EM STOP  
RAMP TIME** This parameter defines the time inside which the drive is stopped upon an Emergency Stop command. The command can be given through fieldbus or the NDIO module Emergency Stop option. For more information on the Emergency Stop option consult the local ABB representative.

**0.00 ... 2000.00 s**

**Group 23 Speed Ctrl** These parameter values can be altered with the ACS 600 running. The Range/Unit column in Table 6-14 below shows the allowable parameter values. The text following the table explains the parameters in detail.

These parameters are not visible in the SCALAR control mode.

Table 6-14 Group 23.

Parameter	Range/Unit	Description
1 GAIN	0.0 ... 200.0	Gain for speed controller.
2 INTEGRATION TIME	0.01 s ... 999.97 s	Integration time for speed controller.
3 DERIVATION TIME	0.0 ... 9999.8 ms	Derivation time for speed controller.
4 ACC COMPENSATION	0.00 s ... 999.98 s	Derivation time used in compensation of acceleration.
5 SLIP GAIN	0.0 % ... 400.0 %	Gain for the slip of the motor.
6 AUTOTUNE RUN	NO; YES	Autotuning of the speed controller.

It is possible to tune the PID algorithm based speed controller of the ACS 600 by setting Parameters 1 to 5 in this group or by selecting the Autotune run by Parameter 6. The Motor ID Run automatically tunes the speed controller. In most cases there is no need to tune it separately.

The values of these parameters define how the output of the Speed Controller changes when there is a difference (error value) between the actual speed and the reference. Figure 6-8 displays typical step responses of the Speed Controller.

Step responses can be seen by monitoring Actual Signal 1.02 SPEED.

---

**Note:** The Standard Motor ID Run (refer to *Chapter 3 – Start-up Data*) updates the values of Parameters 23.01, 23.02 and 23.04.

---

The dynamic performance of the speed control at low speeds can be improved by increasing the relative gain and decreasing the integration time.

Speed controller output is the reference for the torque controller. The torque reference is limited by Parameter 20.04 MAXIMUM TORQUE.

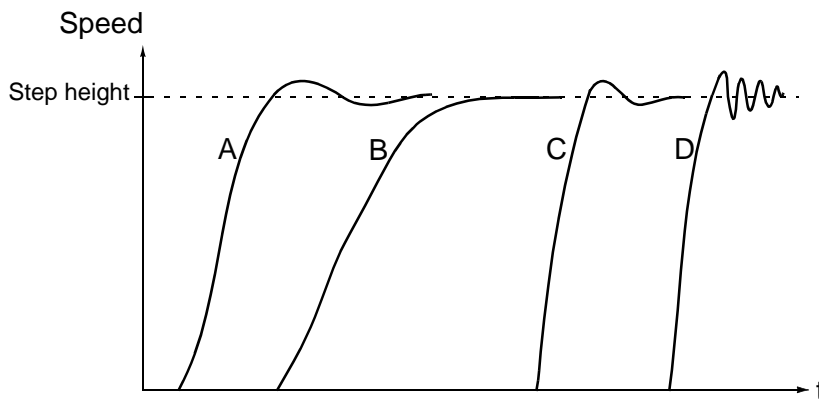

- A : Undercompensated: 23.02 INTEGRATION TIME too short and 23.01 GAIN too low
- B : Normally tuned, autotuning
- C : Normally tuned, manual tuning. Better dynamic performance than with B
- D : Overcompensated: 23.02 INTEGRATION TIME too short and 23.01 GAIN too high

Figure 6-8 Step responses of the Speed Controller with different settings. 1 to 10 % reference step is used.

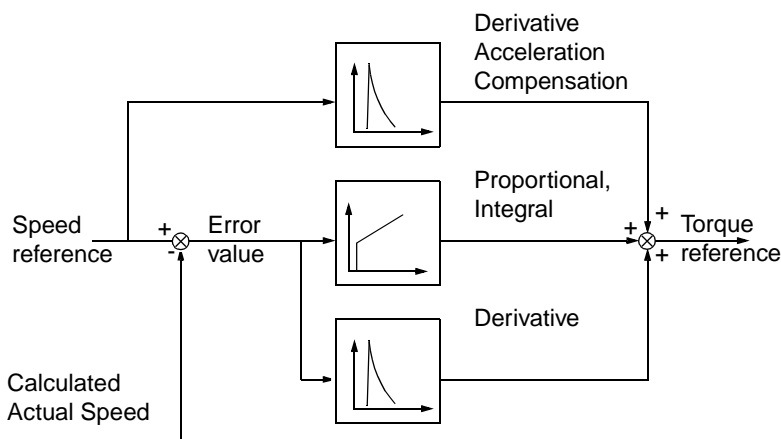

Figure 6-9 Speed controller, a simplified block diagram.

**23.01 GAIN** Relative gain for the speed controller. If you select 1, a 10 % change in error value (e.g. reference - actual value) causes the speed controller output to change 10 % of the nominal torque.

**Note:** Great gain may cause speed oscillation.

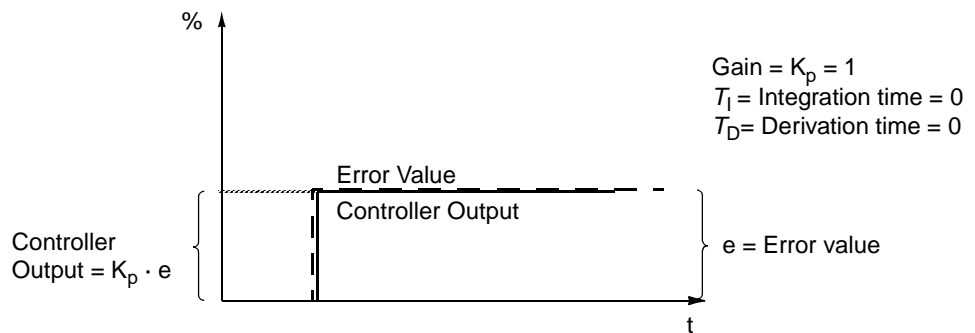

Figure 6-10 Speed Controller Output after an error step when the error remains constant.

23.02 INTEGRATION TIME

Integration time defines the rate at which the controller output changes when the error value is constant. The shorter the integration time, the faster the continuous error value is corrected. Too short integration time makes the control unstable.

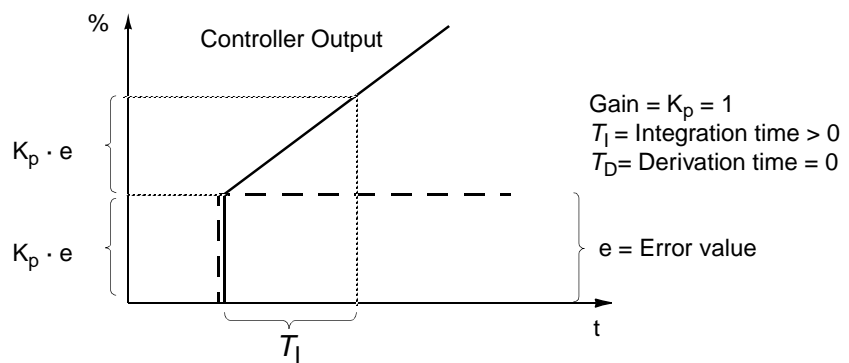

Figure 6-11 Speed Controller Output after an error step when the error remains constant.

23.03 DERIVATION TIME

Derivative action boosts the controller output if the error value changes. The longer the derivation time, the more the speed controller output is boosted during the change. The derivation makes the control more responsive for the disturbances. If derivation time is set to zero, the controller works as a PI controller, otherwise as a PID controller.

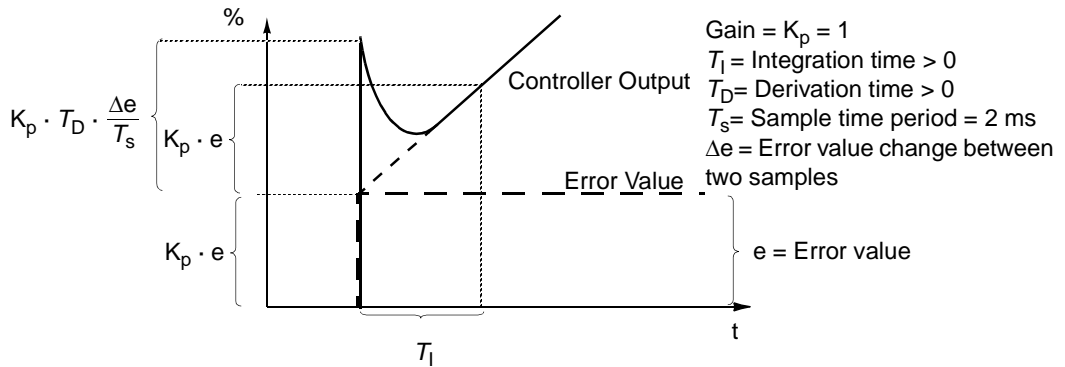

Figure 6-12 Speed Controller Output after an error step when the error remains constant.

**Note:** Changing this parameter is recommended only if a pulse encoder is used.

23.04 ACC COMPENSATION

Derivation time for compensation of acceleration. In order to compensate inertia during acceleration the derivative of the reference is added to the output of the speed controller. The principle of a derivative action is described at 23.03 DERIVATION TIME above.

As a general rule, set this parameter to a value from 50 to 100 % of the sum of the mechanical time constants of the motor and the driven machine.

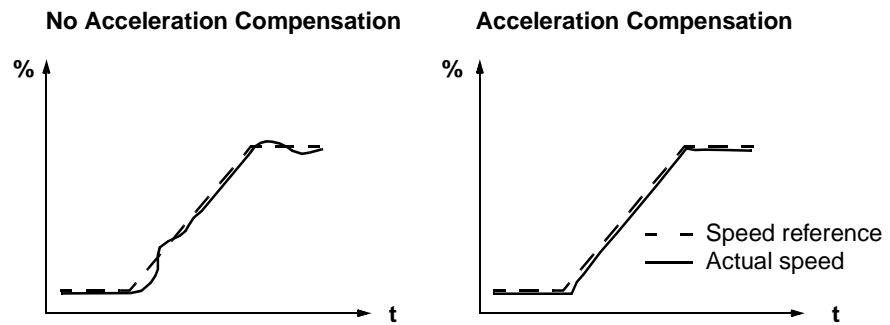

Figure 6-13 Speed responses when a high inertia load is accelerated along a ramp.

**Note:** AUTOTUNE RUN initialises this parameter to 50 % of mechanical time constant.

23.05 SLIP GAIN

Defines the gain for the slip. 100 % means full slip compensation; 0 % means no slip compensation. The default value is 100 %. Other values can be used if static speed error is detected despite of the full slip compensation.

**Example:** 1000 rpm constant speed reference is given to the drive. Despite of the full slip compensation (SLIP GAIN = 100 %) a manual



tachometer measurement from the motor axis gives speed value 998 rpm. The static speed error is 1000 rpm - 998 rpm = 2 rpm. To compensate the error, the slip gain should be increased. At 106 % gain value no static speed error exists.

### 23.06 AUTOTUNE RUN

The speed controller of the ACS 600 can be tuned automatically by performing the Autotune Run. The mechanical inertia of the load is taken into consideration in GAIN, INTEGRATION, DERIVATION and ACC COMPENSATION parameters. The system is tuned to be undercompensated rather than overcompensated.

To perform the Autotune Run:

- Run the motor at a constant speed of 20 to 70 % of the rated speed.
- Change Parameter 23.06 AUTOTUNE RUN to YES.

After the Autotune Run is performed, this parameter value automatically reverts to NO.

---

**Note:** Autotune Run can be performed only while the ACS 600 is running. The motor load must be connected to the motor. The best result is achieved when the motor is run up to 20 ... 40 % of the rated speed before starting the Autotune Run.

---

---

**CAUTION!** The motor will be accelerated by 10 % of the rated speed with 10 ... 20 % torque step without any ramp during this procedure. MAKE SURE THAT IT IS SAFE TO RUN THE MOTOR BEFORE PERFORMING THE AUTOTUNE RUN!

---

**Group 24 Torque Ctrl** This group is visible only if the Torque Control Macro is selected. It is invisible in the SCALAR control mode.

These parameter values can be altered with the ACS 600 running. The Range/Unit column in Table 6-15 below shows the allowable parameter values. The text following the table explains the parameters in detail.

Table 6-15 Group 24.

Parameter	Range/Unit	Description
1 TORQ RAMP UP	0.00 s ... 120.00 s	Time for reference from 0 to the rated torque.
2 TORQ RAMP DOWN	0.00 s ... 120.00 s	Time for reference from the rated torque to 0.

**24.01 TORQ RAMP UP** Defines the time required for the reference to increase from zero to the rated torque.

**24.02 TORQ RAMP DOWN** Defines the time required for the reference to decrease from the rated torque to zero.

**Group 25 Critical Speeds**

These parameter values can be altered with the ACS 600 running. The Range/Unit column in Table 6-16 below shows the allowable parameter values. The text following the table explains the parameters in detail.

In the SCALAR control mode the critical speed ranges are set as Hz.

**Note:** In the PID Control macro (see Parameter 99.02 APPLICATION MACRO), Critical Speeds are not in use.

Table 6-16 Group 25.

Parameter	Range/Unit	Description
1 CRIT SPEED SELECT	OFF; ON	Critical speed jump over logic.
2 CRIT SPEED 1 LOW	0 ... 18000 rpm	Critical speed 1 start.
3 CRIT SPEED 1 HIGH	0 ... 18000 rpm	Critical speed 1 end.
4 CRIT SPEED 2 LOW	0 ... 18000 rpm	Critical speed 2 start.
5 CRIT SPEED 2 HIGH	0 ... 18000 rpm	Critical speed 2 end.
6 CRIT SPEED 3 LOW	0 ... 18000 rpm	Critical speed 3 start.
7 CRIT SPEED 3 HIGH	0 ... 18000 rpm	Critical speed 3 end.

---

**Note:** Using the critical speed lockout function in a closed loop application will cause the system to oscillate if the required output speed is within the critical speed band.

---



---

**Note:** The value of the low speed cannot be higher than the high speed of the same band.

---

In some mechanical systems, certain speed ranges can cause resonance problems. With this Parameter Group, it is possible to set up to three different speed ranges that the ACS 600 will skip over. It is not required that Parameter 25.04 CRIT SPEED 2 LOW is higher than Parameter 25.03 CRIT SPEED 1 HIGH, as long as the LOW parameter of any one set is lower than the HIGH parameter of the same set. Sets may overlap, but the skip will be from the lower LOW value to the higher HIGH value.

To activate the Critical Speed settings, set Parameter 25.01 CRIT SPEED SELECT to ON.

---

**Note:** Set unused Critical Speeds to 0 rpm.

---

**Example:** A fan system has bad vibration from 540 rpm to 690 rpm and from 1380 rpm to 1560 rpm. Set the parameters as follows:

2 CRIT SPEED 1 LOW 540 rpm

3 CRIT SPEED 1 HIGH 690 rpm

4 CRIT SPEED 2 LOW 1380 rpm

5 CRIT SPEED 2 HIGH 1560 rpm

If, due to bearing wear, another resonance occurs at 1020 ... 1080 rpm, the critical speed table can be added to as follows:

6 CRIT SPEED 3 LOW 1020 rpm

7 CRIT SPEED 3 HIGH 1080 rpm

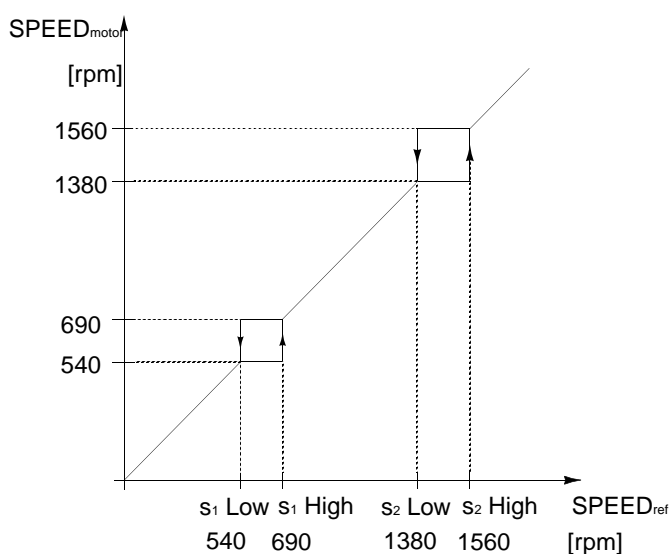

Figure 6-14 Example of critical speed settings in a fan system suffering vibration problems in the speed ranges 540 ... 690 rpm and 1380 ... 1560 rpm.

**Group 26 Motor Control** These parameter values can only be altered with the ACS 600 stopped. The Range/Unit column in Table 6-17 below shows the allowable parameter values. The text following the table explains the parameters in detail.

Table 6-17 Group 26.

Parameter	Range/Unit	Description
1 FLUX OPTIMIZATION	NO; YES	Selection of the flux optimization function.
2 FLUX BRAKING	NO; YES	Selection of the flux braking function.
3 IR COMPENSATION	0 % ... 30 %	Compensation voltage level.
5 HEX FIELD WEAKEN	NO; YES	Activates the motor flux control based on a hexagonal flux pattern.

#### 26.01 FLUX OPTIMIZATION

The total energy consumption and noise can be reduced by changing the magnitude of the flux depending on the actual load. Flux optimization should be activated in drives that usually operate below nominal load.

Flux optimization cannot be selected in the scalar control mode (see Parameter 99.04 MOTOR CTRL MODE).

#### 26.02 FLUX BRAKING

The ACS 600 can provide faster deceleration by raising the level of magnetisation in the motor when needed, instead of limiting the deceleration ramp. By increasing the flux in the motor, the energy of the mechanical system is changed to thermal energy in the motor.

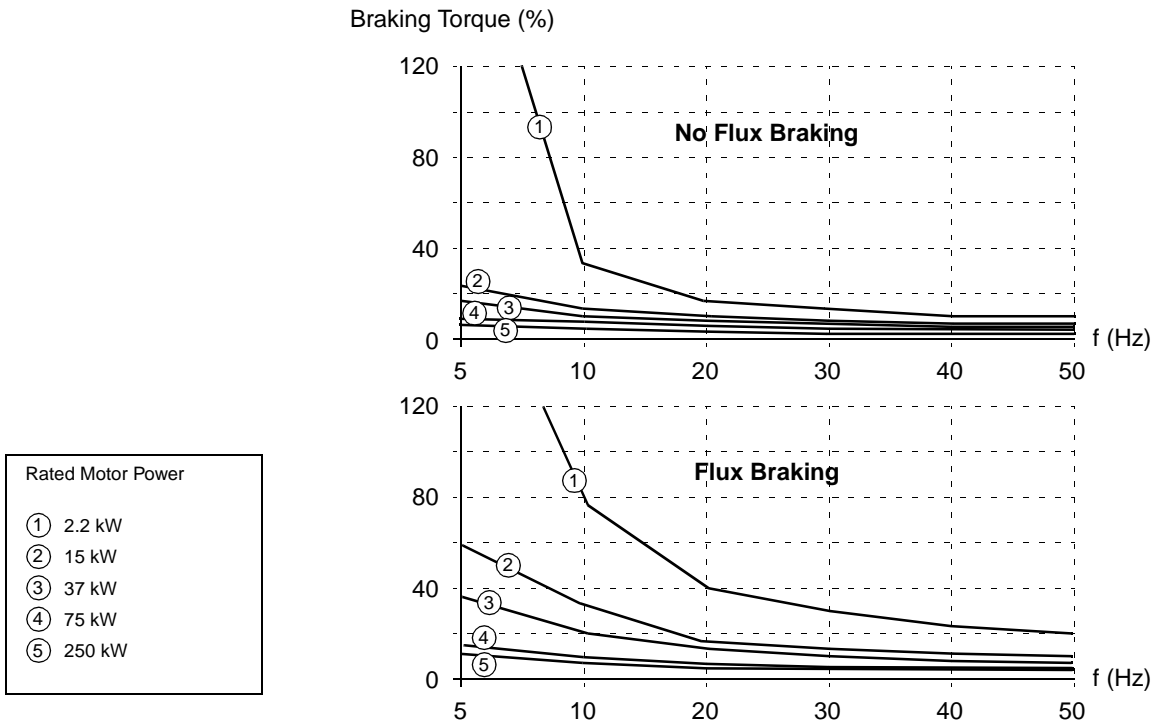

Figure 6-15 Motor braking torque in percent of the rated torque as function of output frequency.

Flux braking cannot be selected in the scalar control mode (see Parameter 99.04 MOTOR CTRL MODE).

26.03 IR COMPENSATION

This parameter is adjustable in the SCALAR control mode only.

This parameter sets the extra relative voltage level that is given to the motor at zero speed. The range is 0 ... 30 % of motor nominal voltage. IR compensation increases the breakaway torque.

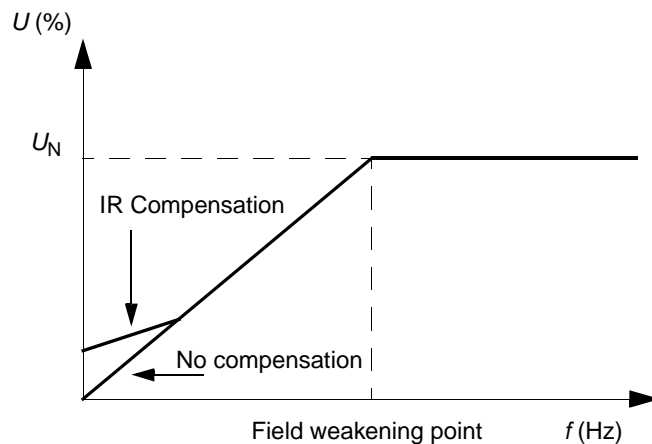

Figure 6-16 IR Compensation is implemented by applying extra voltage to the motor.  $U_N$  is the nominal voltage of the motor.

**26.05 HEX FIELD  
WEAKEN**

This parameter selects whether motor flux is controlled along a circular or a hexagonal pattern in the field weakening area of the frequency range.

**NO**

ACS 600 controls the motor flux in such a way that the rotating flux vector follows a circular pattern. This is the default value and ideal for most applications. However, when operated in the field weakening range, it is not possible to reach 100% output voltage. The peak load capacity of the drive is lower than with the full voltage.

**YES**

Motor flux is controlled along a circular pattern below the field weakening point (FWP, typically 50 or 60 Hz), and along a hexagonal pattern in the field weakening range. The applied pattern is changed gradually as the frequency increases from 100% to 120% of the FWP. Using the hexagonal flux pattern, the maximum output voltage can be reached; The peak load capacity is higher than with the circular flux pattern but the continuous load capacity is lower in the frequency range of FWP to 1.6 x FWP, due to increased losses.

**Group 30 Fault Functions** These parameter values can be altered with the ACS 600 running. The Range/Unit column in Table 6-18 shows the allowable parameter values. The text following the table explains the parameters in detail.

Table 6-18 Group 30.

Parameter	Range/Unit	Description
1 AI<MIN FUNCTION	FAULT; NO; CONST SP 15; LAST SPEED	Operation in case of AI <Minimum fault.
2 PANEL LOSS	FAULT; CONST SP 15; LAST SPEED	Operation in case the Control Panel selected as active control location for the ACS 600 stops communicating.
3 EXTERNAL FAULT	NOT SEL; DI1-DI12	External fault input.
4 MOTOR THERM PROT	FAULT; WARNING; NO	Operation in case of overtemperature.
5 MOT THERM P MODE	DTC; USER MODE; THERMISTOR	Motor thermal protection mode selection.
6 MOTOR THERM TIME	256.0 ... 9999.8 s	Time for 63 % temperature rise.
7 MOTOR LOAD CURVE	50.0 ... 150.0 %	Motor current maximum limit.
8 ZERO SPEED LOAD	25.0 ... 150.0 %	Motor load curve point at zero speed.
9 BREAK POINT	1.0 ... 300.0 Hz	Break point of motor load curve.
10 STALL FUNCTION	FAULT; WARNING; NO	Operation in case of motor stall.
11 STALL FREQ HI	0.5 ... 50 Hz	Frequency limit for stall protection logic.
12 STALL TIME	10.00 ... 400.00 s	Time for stall protection logic.
13 UNDERLOAD FUNC	NO; WARNING; FAULT	Operation in case of underload fault.
14 UNDERLOAD TIME	0.0 ... 600.0 s	Time limit for underload logic.
15 UNDERLOAD CURVE	1 ... 5	Torque limit for underload logic.
16 MOTOR PHASE LOSS	NO; FAULT	Operation in case motor phase is lost.
17 EARTH FAULT	WARNING; FAULT	Operation in case of earth fault.
18 COMM FAULT FUNC	FAULT; NO; CONST SP 15; LAST SPEED	Operation of the drive in case of the Main or Auxiliary Reference Data Set loss.
19 MAIN REF DS T-OUT	0.1 s ... 60 s	Time delay for the Main Data Set supervision function. See Parameter 30.18 COMM FAULT FUNC.
20 COMM FAULT RO/AO	ZERO; LAST VALUE	Operation of the relay output/analogue output in case of the Auxiliary Reference Data Set loss.
21 AUX DS T-OUT	0.1 ... 60.0 s	Time delay for the Auxiliary Data Set supervision function. See Parameter 30.18 COMM FAULT FUNC.
22 IO CONF FUNC	NO; WARNING	Operation in case of an improper use of the optional I/O.



**30.01 AI<MIN FUNCTION** This parameter allows the selection of operation in case the analogue input signal drops below the minimum limit, provided the minimum is set at 0.5 V / 1 mA or above (“living zero”).

---

**CAUTION:** If you select CONST SP 15 or LAST SPEED, make sure that it is safe to continue operation in case analogue input signal is lost.

---

**FAULT**

Fault indication is displayed and the motor coasts to stop.

**NO**

No activity wanted.

**CONST SP 15**

Warning indication is displayed and the speed is set according to Parameter 12.16 CONST SPEED 15.

**LAST SPEED**

Warning indication is displayed and the speed is set to the level the ACS 600 was last operating at. This value is determined by the average speed over the last 10 seconds.

**30.02 PANEL LOSS** Defines the operation of the ACS 600 if the Control Panel selected as the control location for the ACS 600 stops communicating.

---

**CAUTION:** If you select CONST SP 15 or LAST SPEED, make sure that it is safe to continue operation in case communication with the Control Panel fails.

---

**FAULT**

Fault indication is displayed (if there are any Control Panels communicating on the link) and the ACS 600 stops according to the setting of Parameter 21.03 STOP FUNCTION.

**CONST SP 15**

Warning indication is displayed (if there are any Control Panels communicating on the link) and the speed is set according to Parameter 12.16 CONST SPEED 15.

**LAST SPEED**

Warning indication on display (if there are any Control Panels communicating on the link) and the speed is set to the level the ACS 600 was last operating at. This value is determined by the average speed over the last 10 seconds.

**30.03 EXTERNAL FAULT** **NOT SEL**

**DI1-DI12**

This selection defines the digital input used for an external fault signal. If an external fault occurs, i.e. digital input drops to 0 VDC, the ACS 600

is stopped and the motor coasts to stop. A fault message is displayed on the Control Panel.

For the connection of DI7 to DI12, see *Group 98 Option Modules*.

**30.04 MOTOR THERM  
PROT**

This parameter defines the operation of the motor thermal protection function which protects the motor from overheating.

**FAULT**

Displays a warning indication at the warning level. Displays a fault indication and stops the ACS 600 when the motor temperature reaches the 100 % level.

**WARNING**

Warning indication is displayed when the motor temperature reaches the warning level (95 % of the nominal value).

**NO**

No activity wanted.

**30.05 MOT THERM P  
MODE**

Selects the thermal protection mode. The motor protection is made by means of the thermal model or thermistor measurement.

The ACS 600 calculates the temperature of the motor using the following assumptions:

- The motor is in ambient temperature (30 °C) when power is applied to the ACS 600.
- Motor heating is calculated assuming a load curve (Figure 6-19). The motor will heat above nominal temperature if it operates in the region above the curve, and cool if it operates below the curve. The rate of heating and cooling is set by MOTOR THERM TIME.

---

**CAUTION:** Motor thermal protection will not protect the motor if the cooling of the motor is reduced due to dust and dirt.

---

**DTC**

The DTC (Direct Torque Control) load curve is used for calculating heating of the motor. Motor thermal time is approximated for standard self-ventilated squirrel-cage motors as a function of the current of the motor and the number of pole pairs.

It is possible to scale the DTC load curve with Parameter 30.07 MOTOR LOAD CURVE if the motor is used in conditions other than described above. Parameters 30.06 MOTOR THERM TIME, 30.08 ZERO SPEED LOAD and 30.09 BREAK POINT cannot be set.

**Note:** Automatically calculated model (DTC) cannot be applied when 99.06 MOTOR NOM CURRENT > 800 A.

**USER MODE**

In this mode the user can define the operation of thermal protection by

setting Parameters 30.06 MOTOR THERM TIME, 30.08 ZERO SPEED LOAD and 30.09 BREAK POINT.

### THERMISTOR

Motor thermal protection is activated with an I/O signal based on a motor thermistor.

This mode requires a motor thermistor or break contact of a thermistor relay connected between digital input DI6 and +24 V d.c. If direct thermistor connection is used, digital input DI6 supervises the overtemperature as follows:

Thermistor resistance	DI6 Status	Temperature
0 ... 1.5 kohm	"1"	Normal
4 kohm or higher	"0"	Overtemperature

When overtemperature is detected, the drive stops if the Parameter 30.04 MOTOR THERM PROT is set to FAULT.



**WARNING!** According to IEC 664, the connection of the thermistor to the digital input 6 of ACS 600 requires double or reinforced insulation between motor live parts and the thermistor. Reinforced insulation entails a clearance and creeping distance of 8 mm (400/500 VAC equipment). If the thermistor assembly does not fulfil the requirement, the other I/O terminals of ACS 600 must be protected against contact, or a thermistor relay must be used to isolate the thermistor from the digital input.



**WARNING!** In standard application macros, digital input 6 is selected as the source for constant speed selection, Start/Stop or Run Enable signal. Change these settings before selecting THERMISTOR for Parameter 30.05 MOT THERM P MODE. In other words, ensure that digital input 6 is not selected as signal source by any other parameter than 30.05 MOT THERM P MODE.

---

Alternative 1

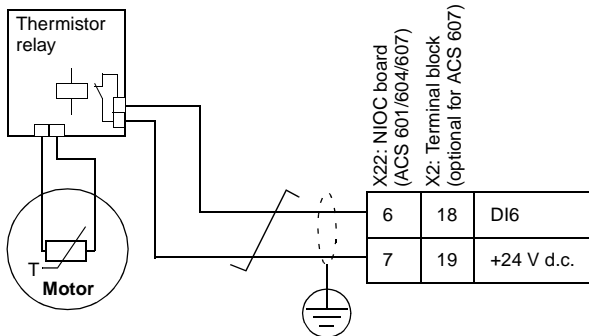

Alternative 2

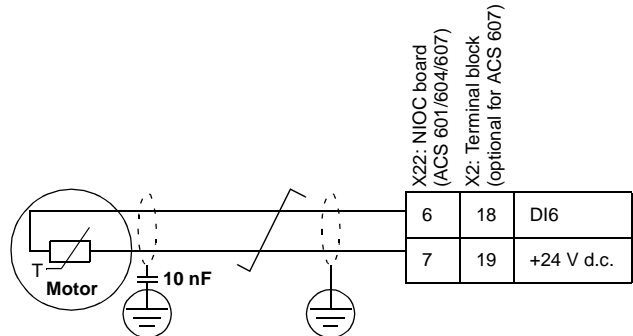

Figure 6-17 Thermistor connection. Alternative 2: At the motor end the cable shield should be earthed through a 10 nF capacitor. If this is not possible, the shield is to be left unconnected.

30.06 MOTOR THERM TIME

This is the time within which the motor temperature reaches 63 % of the final temperature rise. Figure 6-18 shows Motor Thermal Time definition. If the DTC mode is selected for motor thermal protection, motor thermal time can be read from this parameter. This parameter can be set only if Parameter 30.05 MOT THERM P MODE is set to USER MODE.

If thermal protection according to UL requirements for NEMA class motors is desired, use this rule of thumb - Motor Thermal Time equals 35 times  $t_6$  ( $t_6$  in seconds is the time that the motor can safely operate at six times its rated current, given by the motor manufacturer). The thermal time for a Class 10 trip curve is 350 s, for a Class 20 trip curve 700 s and for a Class 30 trip curve 1050 s.

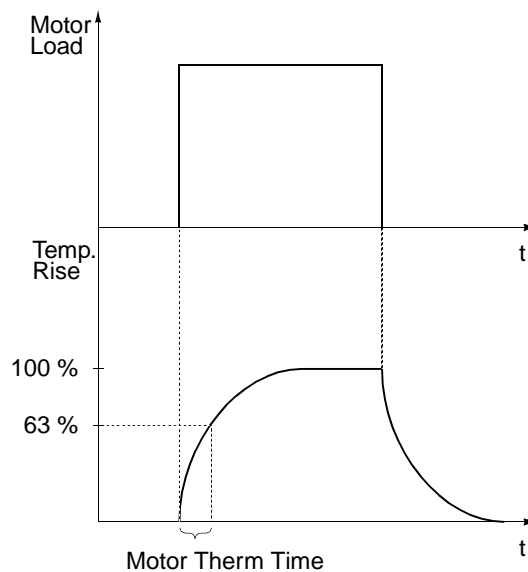

Figure 6-18 Motor Thermal Time.

**30.07 MOTOR LOAD CURVE** The Motor Load Curve sets the maximum allowable operating load of the motor. When set to 100 %, the maximum allowable load is equal to the value of Start-up Data Parameter 99.06 MOTOR NOM CURRENT. The load curve level should be adjusted if the ambient temperature differs from the nominal value.

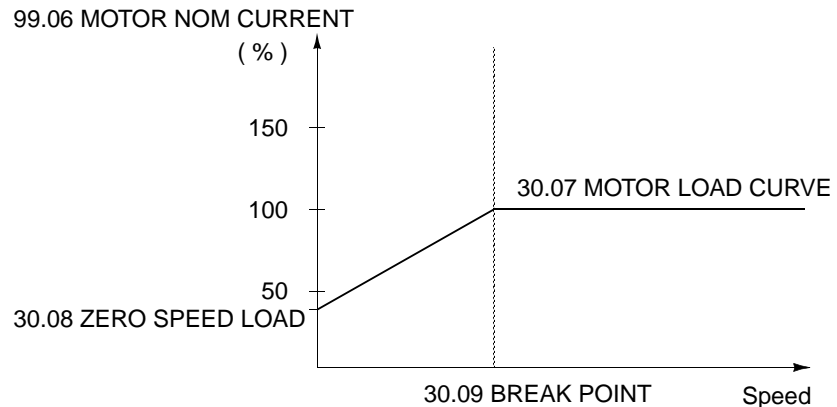

Figure 6-19 Motor Load Curve.

**30.08 ZERO SPEED LOAD** This parameter defines the maximum allowable current at zero speed to define the Motor Load Curve.

**30.09 BREAK POINT** This parameter defines the point at which the motor load curve begins to decrease from the maximum value set by Parameter 30.07 MOTOR LOAD CURVE to the Parameter 30.08 ZERO SPEED LOAD. Refer to Figure 6-19 for an example of motor load curve.

**30.10 STALL FUNCTION** This parameter defines the operation of the stall protection. The protection is activated if the following conditions are valid at a time longer than the period set by Parameter 30.12 STALL TIME.

- The motor torque is close to the internal momentary changing limit of the motor control software that prevents the motor and the inverter from overheating or the motor from pulling out.
- The output frequency is below the level set by Parameter 30.11 STALL FREQ HI.

#### **FAULT**

When the protection is activated the ACS 600 stops and a fault indication is displayed.

#### **WARNING**

A warning indication is displayed. The indication disappears in half of the time set by Parameter 30.12 STALL TIME.

#### **NO**

No activity is wanted.

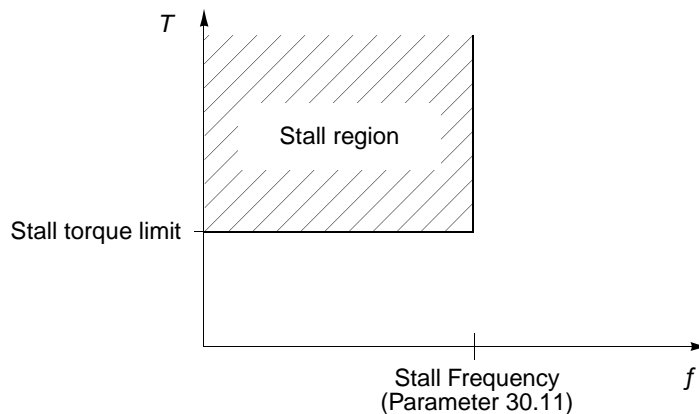

Figure 6-20 Stall protection. *T* is motor torque.

- 30.11 STALL FREQ HI** This parameter sets the frequency value for the stall function.
- 30.12 STALL TIME** This parameter sets the time value for the stall function.
- 30.13 UNDERLOAD FUNC** Removal of motor load may indicate a process malfunction. The protection is activated if:
- The motor torque drops below the load curve selected by Parameter 30.15 UNDERLOAD CURVE.
  - This condition has lasted longer than the time set by Parameter 30.14 UNDERLOAD TIME.
  - Output frequency is higher than 10 % of the nominal frequency of the motor.
- The protection function assumes that the drive is equipped with a motor of the rated power.
- Select NO; WARNING; FAULT according to the activity you prefer. With selection FAULT the ACS 600 stops the motor and displays a fault message.
- 30.14 UNDERLOAD TIME** Time limit for underload logic.
- 30.15 UNDERLOAD CURVE** This parameter provides five selectable curves shown in Figure 6-21. If the load drops below the set curve for longer than the time set by Parameter 30.14 UNDERLOAD TIME, the underload protection is activated. Curves 1 ... 3 reach maximum at the motor rated frequency set by Parameter 99.07 MOTOR NOM FREQUENCY.

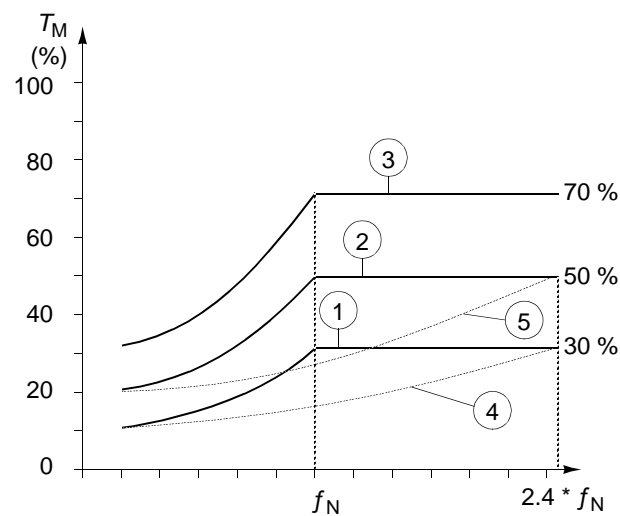

Figure 6-21 Underload curve types.  $T_M$  nominal torque of the motor,  $f_N$  nominal frequency of the motor.

### 30.16 MOTOR PHASE LOSS

This parameter defines the operation when one or more motor phases are lost.

#### **FAULT**

Fault indication is displayed and the ACS 600 stops.

#### **NO**

No activity wanted.

### 30.17 EARTH FAULT

This parameter defines the operation when an earth fault is detected in the motor or the motor cable.

#### **FAULT**

Fault indication is displayed and the ACS 600 stops.

#### **WARNING**

A warning indication is displayed. The drive continues to operate.

### 30.18 COMM FAULT FUNC

This parameter defines the operation on a fieldbus communication loss, i.e. when the drive fails to receive the Main Reference Data Set or the Auxiliary Reference Data Set. See *Appendix C – Fieldbus Control*.

The delay times for the supervision function are defined by Parameter 30.19 MAIN REF DS T-OUT for the Main Reference Data Set, and Parameter 30.21 AUX DS T-OUT for the Auxiliary Reference Data Set.

---

**CAUTION:** If you select CONST SP 15 or LAST SPEED, make sure that it is safe to continue operation in case communication with the communication module fails.

---

**FAULT**

A fault indication is given and the ACS 600 stops according to the setting of Parameter 21.03 STOP FUNCTION.

**NO**

No activity wanted.

**CONST SP 15**

A warning indication is given and the speed is set according to Parameter 12.16 CONST SPEED 15.

**LAST SPEED**

A warning indication is given and the speed is set to the level the ACS 600 was last operating at. This value is determined by the average speed over the last 10 seconds.

30.19 MAIN REF DS  
T-OUT

Time delay for the Main Reference Data Set supervision function. See Parameter 30.18 COMM FAULT FUNC.

Default value is 1 s.

**0.1 ... 60.0 s**

30.20 COMM FAULT  
RO/AO

This parameter defines the operation of the fieldbus controlled relay output and analogue output in a communication loss. See Parameter *Group 14 Relay Outputs, Group 15 Analogue Outputs* and *Appendix C – Fieldbus Control*. Default value is ZERO.

The delay time for the supervision function is equal to value of Parameter 30.21 AUX DS T-OUT.

**ZERO**

Relay output is de-energised. Analogue output is set to zero.

**LAST**

Relay output keeps the last state before the communication loss. Analogue output gives the last value before the communication loss.



---

**WARNING** After the communication recovers, the update of the relay and analogue outputs starts immediately without the fault message resetting.

---

30.21 AUX DS T-OUT

Time delay for the Auxiliary Reference Data Set supervision function. See Parameter 30.18 COMM FAULT FUNC. The drive automatically activates the supervision function 60 seconds after power switch-on if the Auxiliary Reference Data Set is in use i.e. Parameter 90.01 AUX DS REF3, 90.02 AUX DS REF4 or 90.03 AUX DS REF5 has a value other than zero.

The application program also applies this delay time to the function defined with Parameter 30.20 COMM FAULT RO/AO.

Default value is 1 s.

**0.1 ... 60.0 s**



**30.22 IO CONF FUNC** Operation in case of improper use of the inputs/outputs of the optional I/O extension modules in the ACS 600 application program.

**NO**

No indication of improper use of the optional I/O.

**WARNING**

This is the default value. The application program generates a warning “IO CONF” if an optional input or output channel has been selected as a signal interface, but the communication to the appropriate analogue or digital I/O extension module has not been set up accordingly in *Group 98 Option Modules*.

**Example:** The application program generates a warning if Parameter 16.01 RUN ENABLE is set to DI7 but:

- 98.03 DI/O EXT MODULE 1 is set to NO, or
- 98.09 NDIO1 DI FUNC is set to REPL DI1,2

**Group 31 Automatic Reset**

These parameter values can be altered with the ACS 600 running. The Range/Unit column in Table 6-19 below shows the allowable parameter values. The text following the table explains the parameters in detail.

Table 6-19 Group 31.

Parameter	Range/Unit	Description
1 NUMBER OF TRIALS	0 ... 5	Number of faults limit for Autoreset logic.
2 TRIAL TIME	1.0 ... 180.0 s	Time limit for Autoreset logic.
3 DELAY TIME	0.0 ... 3.0 s	Time delay between the fault and the reset attempt.
4 OVERCURRENT	NO; YES	Enable automatic fault reset.
5 OVERVOLTAGE	NO; YES	Enable automatic fault reset.
6 UNDERVOLTAGE	NO; YES	Enable automatic fault reset.
7 AI SIGNAL<MIN	NO; YES	Enable automatic fault reset.

The Automatic fault reset system resets the faults selected with Parameters 31.04 OVERCURRENT, 31.05 OVERVOLTAGE, 31.06 UNDERVOLTAGE and 31.07 AI SIGNAL<MIN.

**31.01 NUMBER OF TRIALS**

Sets the number of allowed autoresets within a certain time. The time is defined with Parameter 31.02 TRIAL TIME. The ACS 600 prevents additional autoresets and remains stopped until a successful reset is performed from the Control Panel or through a digital input.

**31.02 TRIAL TIME**

The time within which a limited number of fault autoresets is allowed. The allowed number of faults per this time period is given with Parameter 31.01 NUMBER OF TRIALS.

**31.03 DELAY TIME**

This parameter sets the time that the ACS 600 will wait after a fault occurs before attempting to reset. If set to zero, the ACS 600 will reset immediately. If set to a value higher than zero, the drive will wait before resetting.

**31.04 OVERCURRENT**

If YES is selected, the fault (motor overcurrent) is reset automatically after the delay set by Parameter 31.03 DELAY TIME and the ACS 600 resumes normal operation.

**31.05 OVERVOLTAGE**

If YES is selected, the fault (DC bus overvoltage) is reset automatically after the delay set by Parameter 31.03 DELAY TIME and the ACS 600 resumes normal operation.

**31.06 UNDERVOLTAGE** If YES is selected, the fault (DC bus undervoltage) is reset automatically after the delay set by Parameter 31.03 DELAY TIME and the ACS 600 resumes normal operation.

**31.07 AI SIGNAL<MIN** If YES is selected, the fault (analogue input signal under minimum level) is reset automatically after the delay set by Parameter 31.03 DELAY TIME.



**WARNING!** If Parameter 31.07 AI SIGNAL<MIN is enabled, the drive may restart even after a long stop when the analogue input signal is restored. Ensure that the use of this feature will not cause physical injury and/or damage equipment.

---

**Group 32 Supervision**

These parameter values can be altered with the ACS 600 running. The Range/Unit column in Table 6-20 below shows the allowable parameter values. The text following the table explains the parameters in detail.

Table 6-20 Group 32.

Parameter	Range/Unit	Description
1 SPEED1 FUNCTION	NO; LOW LIMIT; HIGH LIMIT; ABS LOW LIMIT	Speed 1 supervision.
2 SPEED1 LIMIT	- 18000 ... 18000 rpm	Speed 1 supervision limit.
3 SPEED2 FUNCTION	NO; LOW LIMIT; HIGH LIMIT; ABS LOW LIMIT	Speed 2 supervision.
4 SPEED2 LIMIT	- 18000 ... 18000 rpm	Speed 2 supervision limit.
5 CURRENT FUNCTION	NO; LOW LIMIT; HIGH LIMIT	Motor current supervision.
6 CURRENT LIMIT	0 ... 1000 A	Motor current supervision limit.
7 TORQUE 1 FUNCTION	NO; LOW LIMIT; HIGH LIMIT	Motor torque supervision.
8 TORQUE 1 LIMIT	-400 %... 400 %	Motor torque supervision limit.
9 TORQUE 2 FUNCTION	NO; LOW LIMIT; HIGH LIMIT	Motor torque supervision.
10 TORQUE 2 LIMIT	-400 %... 400 %	Motor torque supervision limit.
11 REF1 FUNCTION	NO; LOW LIMIT; HIGH LIMIT	Reference 1 supervision.
12 REF1 LIMIT	0 ... 18000 rpm	Reference 1 supervision limit.
13 REF2 FUNCTION	NO; LOW LIMIT; HIGH LIMIT	Reference 2 supervision.
14 REF2 LIMIT	0 ... 500 %	Reference 2 supervision limit.
15 ACT1 FUNCTION <sup>*)</sup>	NO; LOW LIMIT; HIGH LIMIT	Actual 1 supervision.
16 ACT1 LIMIT <sup>*)</sup>	0 ... 200 %	Actual 1 supervision limit.
17 ACT2 FUNCTION <sup>*)</sup>	NO; LOW LIMIT; HIGH LIMIT	Actual 2 supervision.
18 ACT2 LIMIT <sup>*)</sup>	0 ... 200 %	Actual 2 supervision limit.

<sup>\*)</sup> These parameters are significant only if the PID Control Macro is selected.

### 32.01 SPEED1 FUNCTION

This parameter allows you to activate a speed supervision function. Relay outputs selected with Parameters 14.01 RELAY RO1 OUTPUT, 14.02 RELAY RO2 OUTPUT and 14.03 RELAY RO3 OUTPUT are used to indicate if the speed drops below (LOW LIMIT) or exceeds (HIGH LIMIT) the supervision limit.

**NO**

Supervision not used.

**LOW LIMIT**

Supervision will be activated if value is below the limit set.

**HIGH LIMIT**

Supervision will be activated if value is above the limit set.

**ABS LOW LIMIT**

Supervision will be activated if value is below the set limit. Limit is supervised in both rotating directions, forward and reverse (see the shaded area on the left).

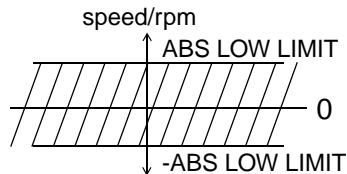

<i>32.02 SPEED1 LIMIT</i>	Speed supervision limit adjustable from -18000 rpm to 18000 rpm.
<i>32.03 SPEED2 FUNCTION</i>	Refer to Parameter 32.01 SPEED1 FUNCTION.
<i>32.04 SPEED2 LIMIT</i>	Speed supervision limit adjustable from -18000 rpm to 18000 rpm.
<i>32.05 CURRENT FUNCTION</i>	Motor current supervision. Same options as with Parameter 32.01 SPEED1 FUNCTION excluding ABS LOW LIMIT.
<i>32.06 CURRENT LIMIT</i>	Motor current supervision limit. Setting in actual amperes, adjustable between 0 A ... 1000 A.
<i>32.07 TORQUE1 FUNCTION</i>	Motor torque supervision. Same options as with Parameter 32.01 SPEED1 FUNCTION excluding ABS LOW LIMIT.
<i>32.08 TORQUE1 LIMIT</i>	Motor torque supervision limit. Setting in -400 % ... 400 % of the nominal torque of the motor.
<i>32.09 TORQUE2 FUNCTION</i>	Motor torque supervision. Same options as with Parameter 32.01 SPEED1 FUNCTION excluding ABS LOW LIMIT.
<i>32.10 TORQUE2 LIMIT</i>	Motor torque supervision limit. Setting in -400 % ... 400 % of nominal torque of the motor.
<i>32.11 REF1 FUNCTION</i>	Reference 1 supervision. Same options as with Parameter 32.01 SPEED1 FUNCTION excluding ABS LOW LIMIT.
<i>32.12 REF1 LIMIT</i>	Reference 1 supervision limit adjustable from 0 to 18000 rpm.
<i>32.13 REF2 FUNCTION</i>	Reference 2 supervision. Same options as with Parameter 32.01 SPEED1 FUNCTION excluding ABS LOW LIMIT.
<i>32.14 REF2 LIMIT</i>	Reference 2 supervision limit adjustable from 0 to 200 %.
<i>32.15 ACT1 FUNCTION</i>	Actual value 1 supervision. Same options as with Parameter 32.01 SPEED1 FUNCTION, except that relay output RO3 cannot be used and excluding ABS LOW LIMIT.
<i>32.16 ACT1 LIMIT</i>	Actual value 1 supervision limit adjustable from 0 to 200 %.

**32.17 ACT2 FUNCTION** Actual value 2 supervision. Same options as with Parameter 32.01 SPEED1 FUNCTION, except that relay output RO3 cannot be used and excluding ABS LOW LIMIT.

**32.18 ACT2 LIMIT** Actual value 2 supervision limit adjustable from 0 to 200 %.

**Group 33 Information** These parameter values cannot be altered. The Range/Unit column in Table 6-21 below shows the parameter values. The text following the table explains the parameters in detail.

Table 6-21 Group 33.

Parameter	Range/Unit	Description
1 SOFTWARE VERSION	xxxxxxx	Version of the software package.
2 APPL SW VERSION	xxxxxxx	Version of the application software.
3 TEST DATE	DDMMYY	Test date (Day, Month, Year).

**33.01 SOFTWARE VERSION** This parameter displays the type, and the version of the firmware package loaded into the ACS 600.

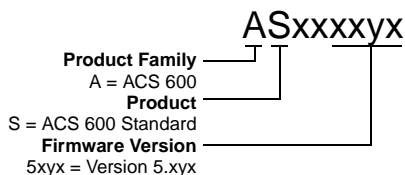

**33.02 APPL SW VERSION** This parameter displays the type, and the version of the application program of your ACS 600.

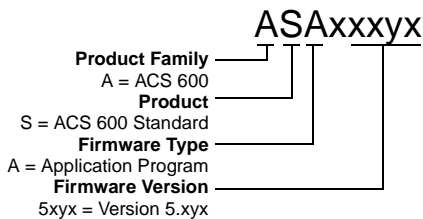

**33.03 TEST DATE** This parameter displays the test date of your ACS 600.

**Group 34 Process Variable**

These parameter values can be altered with the ACS 600 running. The Range/Unit column in Table 6-22 below shows the allowable parameter values. The text following the table explains the parameters in detail.

Table 6-22 Group 34.

Parameter	Range/Unit	Description
1 SCALE	0.00 ... 100000.00	Scaling factor for the process variable
2 P VAR UNIT	NO; rpm; ... ; FPM	Unit of the process variable
3 SELECT P VAR	0 to 9999	Selects the ACS 600 variable to be scaled into a process variable
4 MOTOR SP FILT TIM	0 to 20000 ms	Filter time for actual speed
5 TORQ ACT FILT TIM	0. to 20000 ms	Filter time for actual torque
6 RESET RUN TIME	NO; YES	Reset for the counter 1.43 MOTOR RUN TIME

*Function Description:  
Process Variable  
Definition*

The block diagram below illustrates the use of the parameters that define actual signal 1.01 PROCESS VARIABLE

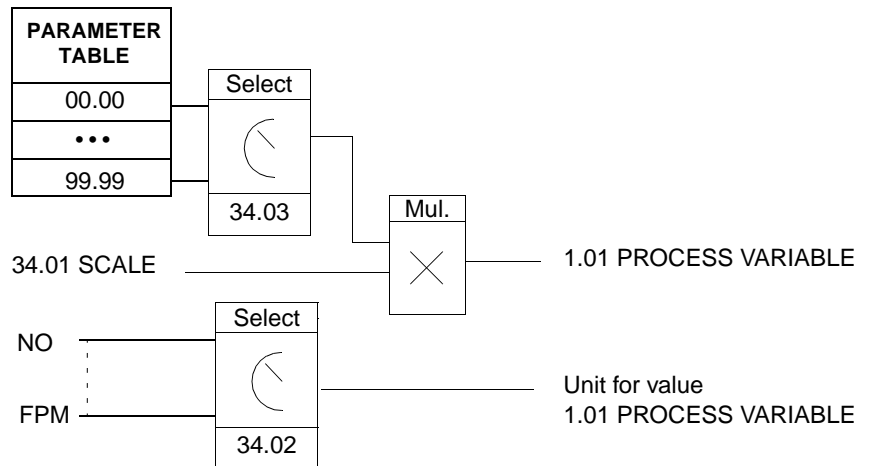

**34.01 SCALE** This parameter scales the selected ACS 600 variable into a desired process variable. Default value is 100.00. See section *Function Description: Process Variable Definition* above.

**34.02 P VAR UNIT** This parameter selects the unit for the process variable. See section *Function Description: Process Variable Definition* above.

**NO**  
No unit is selected.

**rpm; %; m/s; A; V; Hz; s; h; kh; C; lft** (labels per foot); **mA; mV; kW; W; kWh; F; hp; MWh; m3h** (m<sup>3</sup>/h); **l/s** (dm<sup>3</sup>/s); **bar; kPa; GPM** (gallons per minute); **PSI** (pounds per square inch); **CFM** (cubic feet per minute); **ft; MGD** (millions of gallons per day); **iHg** (inches of mercury); **FPM** (feet per minute)

Possible choices for the unit. The default value is %.

**34.03 SELECT P VAR**

This parameter selects the ACS 600 variable that is scaled into a desired process variable. Default value is 142 (i.e. Actual Signal 1.42 PROCESS SPEED REL). See section *Function Description: Process Variable Definition* above.

**34.04 MOTOR SP FILTER  
TIM**

Sets a filter time for actual speed signal. Has an effect on:

- 1.02 SPEED
- speed read through an analogue output
- 32.01 SPEED1 FUNCTION and 32.03 SPEED2 FUNCTION

**0 to 20000 ms**

Default value is 500 ms

**34.05 TORQ ACT FILT  
TIM**

Sets a filter time for actual torque signal. Has an effect on:

- 1.05 TORQUE
- torque read through an analogue output
- 32.07 TORQUE1 FUNCTION and 32.09 TORQUE2 FUNCTION

**0 to 20000 ms**

Default value is 100 ms

**34.06 RESET RUN TIME**

Selecting YES resets the counter 1.43 MOTOR RUN TIME.

**NO; YES**



**Group 35 Mot Temp Meas**

The parameters of the motor temperature measurement function are included in this group.

The table below lists the parameters. The detailed parameter descriptions are given after two application examples.

*Table 6-23 Group 35.*

Parameter	Range/Unit	Description
1 MOT1 TEMP AI1 SEL	NOT IN USE; 1XPT100; 2XPT100, 3XPT100, 1..3 PTC	Motor 1 temperature sensor type.
2 MOT 1 TEMP ALM L	-10 to 5000 °C / ohm	Alarm limit for motor 1 temperature measurement.
3 MOT 1 TEMP FLT L	-10 to 5000 °C / ohm	Fault limit for motor 1 temperature measurement.
4 MOT2 TEMP AI2 SEL	NOT IN USE; 1XPT100; 2XPT100, 3XPT100, 1..3 PTC	Motor 2 temperature sensor type.
5 MOT 2 TEMP ALM L	-10 to 5000 °C / ohm	Alarm limit for motor 2 temperature measurement.
6 MOT 2 TEMP FLT L	-10 to 5000 °C / ohm	Fault limit for motor 2 temperature measurement.
7 MOT MOD COMPENSAT	NO; YES	Motor model temperature compensation by measured value.

*Application Example:  
Temperature  
Measurement through the  
NIOC Board*



The figure below shows the temperature measurement of one motor using the Standard I/O Board, NIOC.

**WARNING!** According to IEC 664, the connection of the motor temperature sensor to the Standard IO Board, NIOC, requires double or reinforced insulation between motor live parts and the sensor. Reinforced insulation entails a clearance and creeping distance of 8 mm (400/500 VAC equipment). If the assembly does not fulfil the requirement:

- The NIOC terminals must be protected against contact and they may not be connected to other equipment.

Or

- The temperature sensor must be isolated from the NIOC board terminals.

**Parameter Settings**

15.01 ANALOGUE OUTPUT1 (O)	M1 TEMP MEAS
35.01 MOT1 TEMP AI1 SEL	To be set according to the type and number of sensors
35.02 MOT 1 TEMP ALM L	Alarm limit for motor 1
35.03 MOT 1 TEMP FLT L	Fault limit for motor 1
98.12 AI/O MOTOR TEMP	NO
<b>Note:</b> Parameters 13.01 MINIMUM AI1 to 13.05 INVERT AI1 and 15.02 INVERT AO1 to 15.05 SCALE AO1 are not effective.	

**Actual values**

1.35 MOTOR 1 TEMP, 3.08 ALARM WORD 1, 3.12 FAULT WORD 3, 3.16 ALARM WORD 3
--

**Warnings** (See Chapter 7 – Fault Tracing and Group 3 Actual Signals)

MOTOR 1 TEMP, MOTOR 2 TEMP, T MEAS ALM
--

**Faults** (See Chapter 7 – Fault Tracing and Group 3 Actual Signals)

MOTOR 1 TEMP, MOTOR 2 TEMP
----------------------------

**Other**

At the motor end the cable shield should be earthed through a 10 nF capacitor. If this is not possible, the shield is to be left unconnected.
---

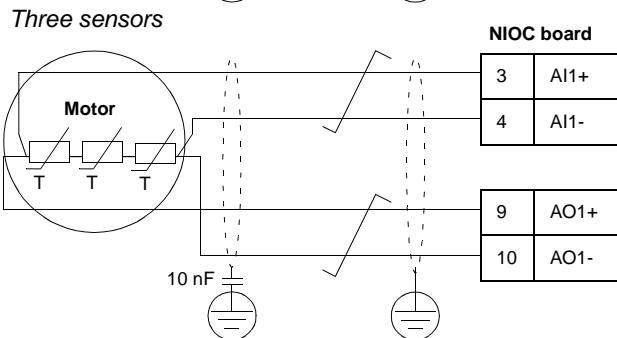
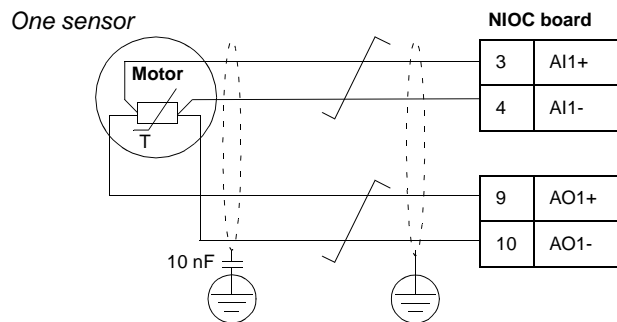

*Application Example:  
Temperature  
Measurement through the  
NAIO Module*



The figure below shows the temperature measurement of one motor through an optional Analogue I/O Extension Module, NAIO.

**WARNING!** According to IEC 664, the connection of the motor temperature sensor to NAIO module requires double or reinforced insulation between motor live parts and sensor. Reinforced insulation entails a clearance and creeping distance of 8 mm (400/500 VAC equipment). If the assembly does not fulfil the requirement:

- The NAIO terminals must be protected against contact and they may not be connected to other equipment. The NAIO module power supply output must also have isolation level of 2.5 kV (note that the NIOC board does not fulfil this requirement).

Or

- The temperature sensor must be isolated from the NAIO module terminals.

**Parameter Settings**

35.01 MOT1 TEMP AI1 SEL	To be set according to the type and number of sensors
35.02 MOT 1 TEMP ALM L	Alarm limit for motor 1
35.03 MOT 1 TEMP FLT L	Fault limit for motor 1
98.12 AI/O MOTOR TEMP	UNIPOLAR

**Actual values**

1.35 MOTOR 1 TEMP, 3.08 ALARM WORD 1, 3.12 FAULT WORD 3, 3.16 ALARM WORD 3
--

**Warnings** (See Chapter 7 – Fault Tracing and Group 3 Actual Signals)

MOTOR 1 TEMP, MOTOR 2 TEMP, T MEAS ALM
--

**Faults** (See Chapter 7 – Fault Tracing and Group 3 Actual Signals)

MOTOR 1 TEMP, MOTOR 2 TEMP
----------------------------

**Other**

At the motor end, the cable shield should be earthed through a 10 nF capacitor. If this is not possible, the shield is to be left unconnected.

The NAIO module must also be connected to a power supply. See the module manual.

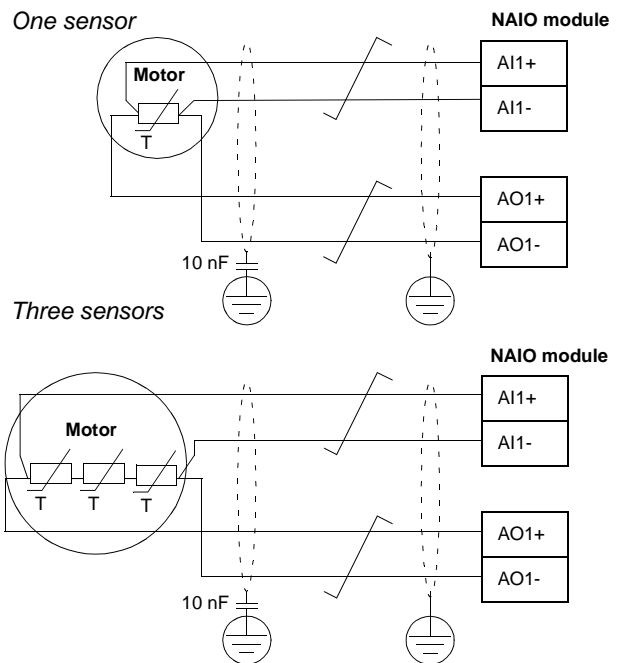

**35.01 MOT1 TEMP AI1 SEL**

The Parameter activates the motor 1 temperature measurement function, and selects the sensor type. See the following subsections above:

- *Application Example: Temperature Measurement through the NIOC Board*
- *Application Example: Temperature Measurement through the NAIO Module*

**NOT IN USE**

Motor 1 temperature is not measured. This is the default setting.

**1xPT100; 2xPT100; 3xPT100**

Motor 1 temperature is measured using one to three Pt 100 sensors.

The analogue output AO1 feeds a constant current through the sensor. The resistance of the sensor increases linearly as the motor temperature rises, as does the voltage over the sensor. The temperature measurement function reads the voltage through an analogue input AI1 and converts it into degrees centigrade.

**1..3 PTC**

Motor 1 temperature is supervised by one to three PTC sensors.

The analogue output AO1 feeds a constant current through the sensor(s). The resistance of the sensor increases sharply as the motor temperature rises over the PTC reference temperature ( $T_{ref}$ ), as does the voltage over the resistor. The temperature measurement function reads the voltage through the analogue input AI1 and converts it into ohms.

The figure below shows typical PTC sensor resistance values as a function of the motor operating temperature.

Temperature	Resistance
Normal	0 to 1.5 k ohm
Overtemperature	$\geq 4$ kohm

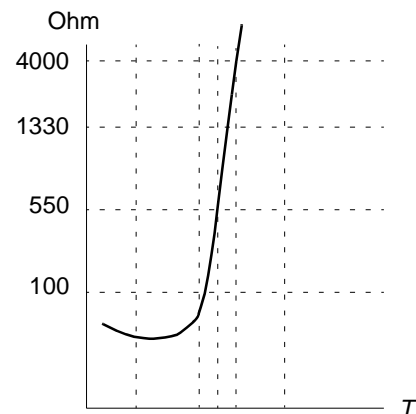

**35.02 MOT 1 TEMP ALM L**

Sets the alarm limit for the motor 1 temperature measurement. The alarm indication is given when the limit is exceeded.

**-10 to 5000 °C**

Alarm limit if Parameter 35.01 MOT1 TEMP AI1 SEL is 1xPT100; 2xPT100; 3xPT100. Default value is 110 °C.

- 10 to 5000 ohm**  
Alarm limit if Parameter 35.01 MOT1 TEMP AI1 SEL is 1..3 PTC.  
Default value is 110 ohm.
- 35.03 MOT 1 TEMP FLT L** Sets the fault trip limit for the motor 1 temperature measurement. The fault indication is given when the limit is exceeded.
- 10 to 5000 °C**  
Fault trip limit if Parameter 35.01 MOT1 TEMP AI1 SEL is 1xPT100; 2xPT100; 3xPT100. Default value is 130 °C.
- 10 to 5000 ohm**  
Fault trip limit if Parameter 35.01 MOT1 TEMP AI1 SEL is 1..3 PTC.  
Default value is 130 ohm.
- 35.04 MOT2 TEMP AI2 SEL** The parameter activates the motor 2 temperature measurement function, and selects the sensor type. See the subsection *Application Example: Temperature Measurement through the NAI0 Module* above.
- 
- Note:** Two motors can be protected only by using an optional Analogue Extension Module, NAI0. If Parameter 98.12 AI/O MOTOR TEMP is set, the NAI0 module is taken into use, and it is also used in the motor 1 temperature measurement (the Standard I/O Board, NIOC, is not in use).
- 
- NOT IN USE**  
Motor 2 temperature is not measured. This is the default setting.
- 1xPT100; 2xPT100; 3xPT100**  
Motor 2 temperature is measured using one to three Pt 100 sensors. See 35.01 MOT1 TEMP AI1 SEL
- 1..3 PTC**  
Motor 2 temperature is supervised by one to three PTC sensors. See 35.01 MOT1 TEMP AI1 SEL
- 35.05 MOT 2 TEMP ALM L** Sets the alarm limit for the motor 2 temperature measurement function. The alarm indication is given when the limit is exceeded.
- 10 to 5000 °C**  
Alarm limit if Parameter 35.04 MOT2 TEMP AI2 SEL is 1xPT100; 2xPT100; 3xPT100. Default value is 110 °C.
- 10 to 5000 ohm**  
Alarm limit if Parameter 35.04 MOT2 TEMP AI2 SEL is 1..3 PTC.  
Default value is 110 ohm.
- 35.06 MOT 2 TEMP FLT L** Sets the fault trip limit for the motor 2 temperature measurement function. The fault indication is given when the limit is exceeded.
- 10 to 5000 °C**  
Fault limit if Parameter 35.04 MOT2 TEMP AI2 SEL is 1xPT100; 2xPT100; 3xPT100. Default value is 110 °C.

**-10 to 5000 ohm**

Fault limit if Parameter 35.04 MOT2 TEMP AI2 SEL is 1..3 PTC.  
Default value is 110 ohm.

**35.07 MOT MOD  
COMPENSATION**

Parameter selects whether the measured motor 1 temperature is used in the motor model compensation.

**NO**

Measured motor 1 temperature is not used.

**YES**

Measured motor 1 temperature is used in motor model compensation.

**Note:** Selection is possible only when Pt 100 sensor(s) is used.

**Group 40 PID Control** The parameter group includes parameters for three functions:

- process PID control (in use only when Parameter 99.02 APPLICATION MACRO is PID CTRL).
- speed or torque reference trimming (in use only when Parameter 99.02 APPLICATION MACRO is **not** PID CTRL).
- sleep function for the process PID control (in use only when Parameter 99.02 APPLICATION MACRO is PID CTRL).

Table 6-24 below shows the parameters. The functions are described on the following pages. The text following the function descriptions explains the parameters in detail. The parameter values can be altered with the ACS 600 running.

Table 6-24 Group 40.

Parameter	Range/Unit	Description
1 PID GAIN	0.1 ... 100	PID Controller Gain selection.
2 PID INTEG TIME	0.02 ... 320.00 s	PID Controller I-time selection.
3 PID DERIV TIME	0.00 ... 10.00 s	PID Controller D-time selection.
4 PID DERIV FILTER	0.04 ... 10.00 s	Time constant for the filter of the D-term.
5 ERROR VALUE INV	NO; YES	PID Controller error value inversion.
6 ACTUAL VALUE SEL	ACT1; ACT1 - ACT2; ACT1 + ACT2; ACT1 * ACT2; ACT1/ACT2; MIN(A1,A2); MAX(A1,A2); sqrt(A1 - A2); sqA1 + sqA2	PID Controller actual signal selection.
7 ACTUAL1 INPUT SEL	AI1; AI2; AI3; AI5; AI6; CURRENT; TORQUE; POWER	Actual 1 signal input selection.
8 ACTUAL2 INPUT SEL	AI1; AI2; AI3; AI5; AI6; CURRENT; TORQUE; POWER	Actual 2 signal input selection.
9 ACT1 MINIMUM	-1000 ... 1000 %	Minimum scaling factor of the Actual 1.
10 ACT1 MAXIMUM	-1000 ... 1000 %	Maximum scaling factor of the Actual 1.
11 ACT2 MINIMUM	-1000 ... 1000 %	Minimum scaling factor of the Actual 2.

Parameter	Range/Unit	Description
12 ACT2 MAXIMUM	-1000 ... 1000 %	Maximum scaling factor of the Actual 2
13 PID INTEGRATION	ON; OFF	On/Off switch for the PID control block integrator
14 TRIM MODE <sup>1)</sup>	OFF; PROPORTIONAL; DIRECT	Enables/disables trim function and selects between direct and proportional trimming
15 TRIM REF SEL <sup>1)</sup>	AI1; AI2; AI3; AI5; AI6; PAR 40.16	Selects the signal source for the trim reference
16 TRIM REFERENCE <sup>1)</sup>	-100.0% to 100.0%	Fixed trim reference value (for 40.15 TRIM REF SEL)
17 TRIM RANGE ADJUST <sup>1)</sup>	-100.0% to 100.0%	Multiplier for the PID control block output. Used in the trim function
18 TRIM SELECTION <sup>1,2)</sup>	SPEED TRIM; TORQUE TRIM	Selects between speed and torque reference trimming
19 ACTUAL FILT TIME	0.04 s to 10.00s	Filter time for the actual signals connected to the PID control block
20 SLEEP SELECTION <sup>3)</sup>	OFF; INTERNAL; DI1; DI2; DI3; DI4; DI5; DI6; DI7; DI8; DI9; DI10; DI11; DI12	Sleep function control
21 SLEEP LEVEL <sup>3)</sup>	0.0 to 7200.0 rpm	Sleep activation speed
22 SLEEP DELAY <sup>3)</sup>	0.0 s to 3600.0 s	Sleep activation delay
23 WAKE UP LEVEL <sup>3)</sup>	0.0 % to 100.0 %	Sleep deactivation level (actual value in the process PID ctrl)
24 WAKE UP DELAY <sup>3)</sup>	0.0 s to 3600.0 s	Sleep deactivation delay

<sup>1)</sup> Not visible with 99.02 APPLICATION MACRO = PID CTRL, <sup>2)</sup> Visible only when 99.02 APPLICATION MACRO = T CTRL, <sup>3)</sup> Visible only when 99.02 APPLICATION MACRO = PID CTRL.



**Function Description:**  
**Process PID Control**

The process PID control adjusts the drive speed in order to keep the measured process quantity (actual value) at the desired level (reference).

The block diagram below on the right illustrates the process PID control. The minimum and maximum values of the PID controller output are the same as Parameter 20.01 MINIMUM SPEED and 20.02 MAXIMUM SPEED (or 20.07 MINIMUM FREQ and 20.08 MAXIMUM FREQ).

The figure on the left shows an application example: The process PID controller adjusts the speed of a pressure boost pump according to the measured pressure and the set pressure reference.

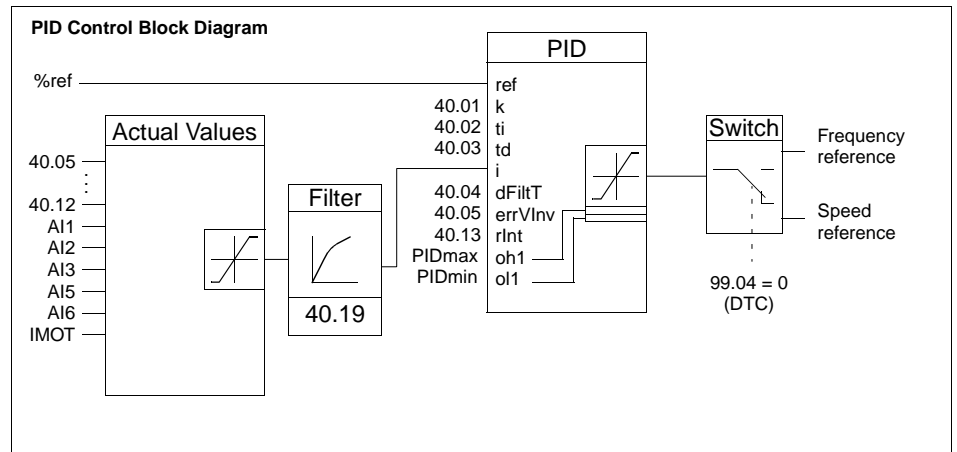
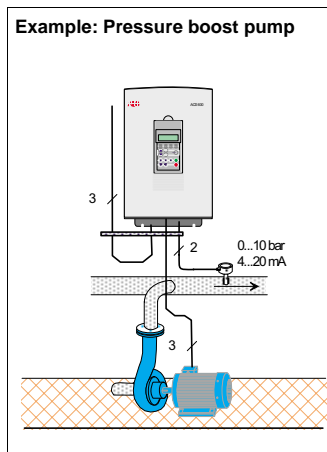

**Function Description:** In trimming, the drive external %-reference (External reference 2) is corrected. The block diagram below illustrates the function.  
**Reference Trimming**

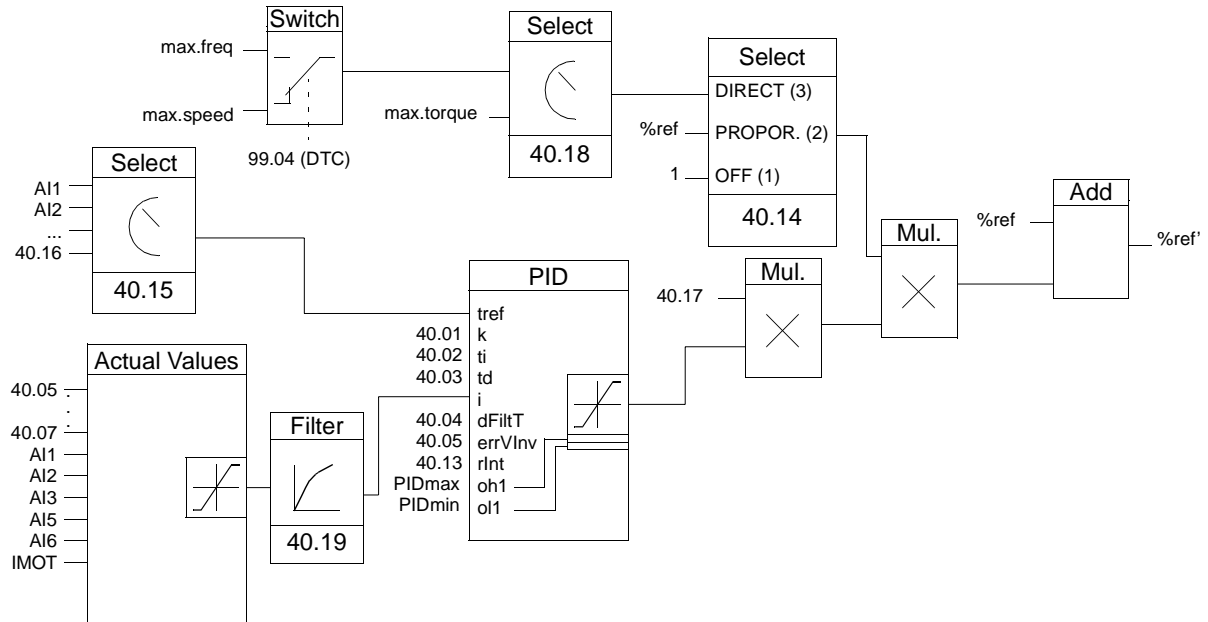

**%ref**  
 The drive reference before trimming

**%ref'**  
 The drive reference after trimming

**max. speed**  
 = 20.02 MAXIMUM SPEED (or 20.01 MINIMUM SPEED if the absolute value is greater)

**max freq**  
 = 20.08 MAXIMUM FREQ (or 20.07 MINIMUM FREQ if the absolute value is greater)

**max. torq**  
 = 20.04 MAXIMUM TORQUE (or 20.10 SET MIN TORQUE if the absolute value is greater)

**Example:** A speed controlled conveyor line where the line tension also needs to be considered: The drive is speed controlled. In addition, the line tension is monitored. If the measured tension increases too much (above the tension setpoint) the speed is slightly decreased, and vice versa. To accomplish the desired speed correction, the user:

- activates the trimming function and connects the tension setpoint and the measured tension to the trimming function
- tunes the trimming to a suitable level

#### Speed controlled conveyor line

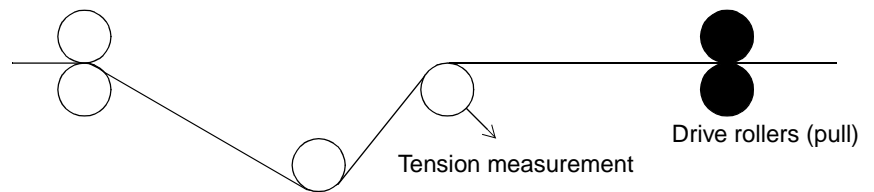

#### Speed reference trimming

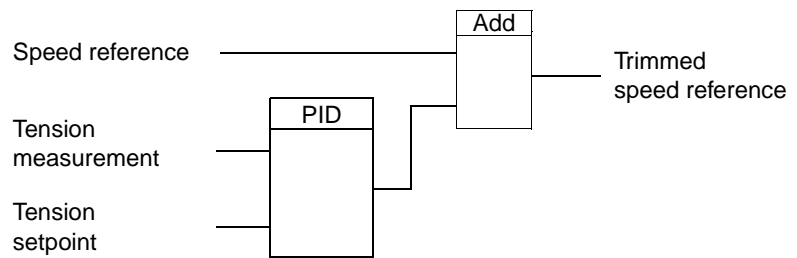

**Function Description:** The block diagram below illustrates the sleep function enable/disable logic. The sleep function can be put into use only when Parameter 99.02 APPLICATION MACRO is PID CTRL.  
**Sleeping**

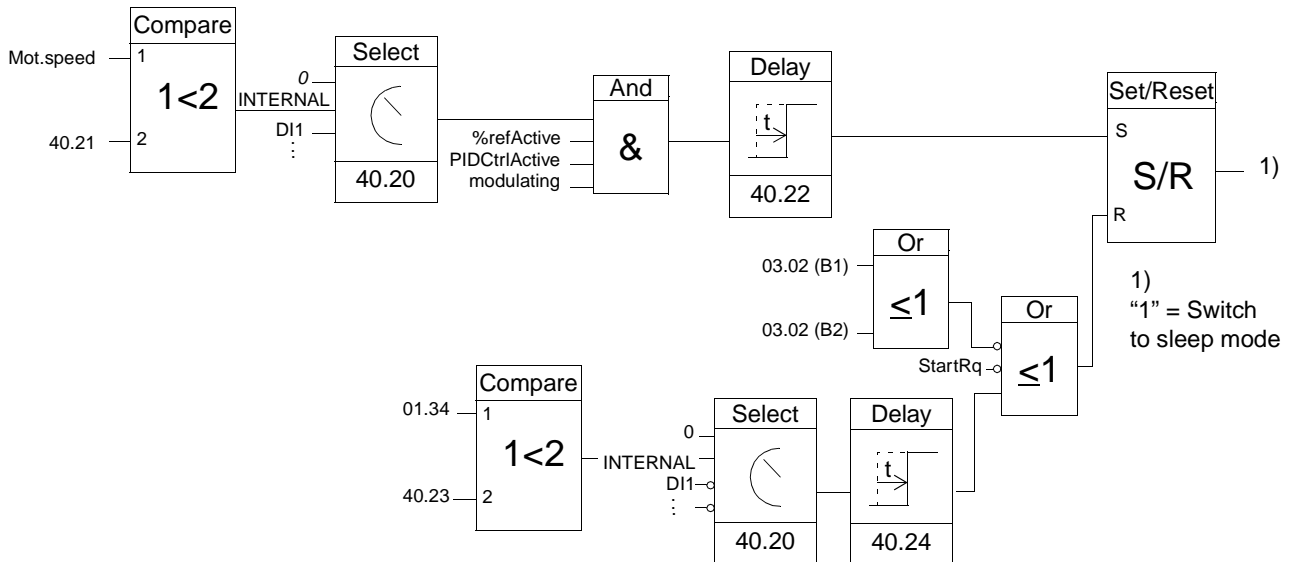

**Mot.speed:** Actual speed of the motor

**%refActive:** The % reference is in use (instead of the rpm (speed) reference)

**PIDCtrlActive:** 99.02 APPLICATION MACRO is PID CTRL

**modulating:** The inverter IGBT control is operating

The time sceme below visualises the operation of the sleep function.

**Application example: Sleep function and a PID controlled pressure boost pump** (see also the subsection *Function Description: Process PID Control* above)

The water consumption falls at night. As a consequence, the PID process controller decreases the motor speed. However, due to natural losses in the pipes and the low efficiency of the centrifugal pump at low speed, the motor does not stop but keeps rotating. The sleep function detects the slow rotating, and stops the unnecessary pumping after the sleep delay has passed. The drive shifts into sleep mode, still monitoring the pressure: The pumping restarts when the pressure falls under the allowed minimum level and the wake-up delay has passed.

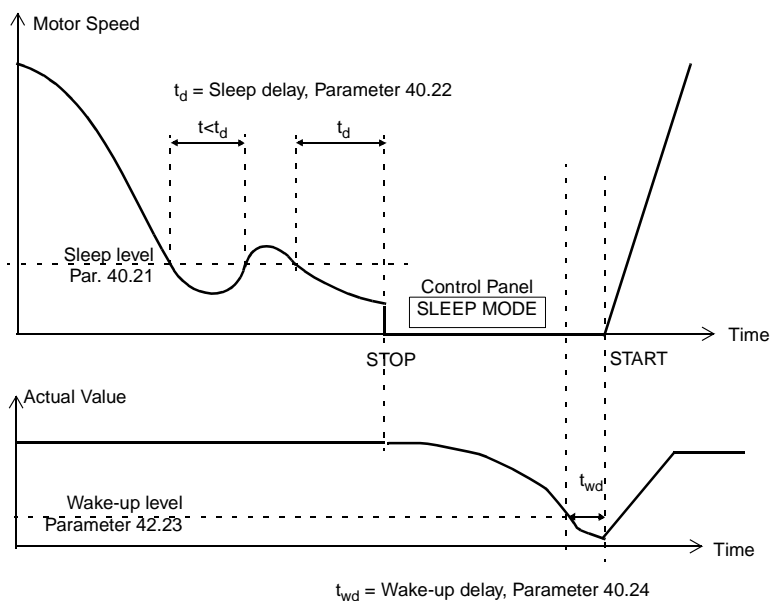

**40.01 PID GAIN** This parameter defines the gain of the PID Controller. The setting range is 0.1 ... 100. If you select 1, a 10 % change in error value causes the PID Controller output to change by 10 %. If the 20.02 MAXIMUM SPEED is set to 1500 rpm, the actual speed reference is changed by 150 rpm.

Table 6-25 below lists a few examples of gain settings, and the resulting speed change to a 10 % change in error value and a 50 % change in error value.

Table 6-25 Gain Settings (MAXIMUM SPEED is 1500 rpm).

PID Gain	Speed Change for a 10 % Change in Error	Speed Change for a 50 % Change in Error
0.5	75 rpm	375 rpm
1.0	150 rpm	750 rpm
3.0	450 rpm	1500 rpm (limited by parameter 20.02 MAXIMUM SPEED)

**40.02 PID INTEG TIME** Defines the time in which the maximum output is achieved if a constant error value exists and the gain is 1. Integration time 1 s denotes that a 100 % change is achieved in 1 s.

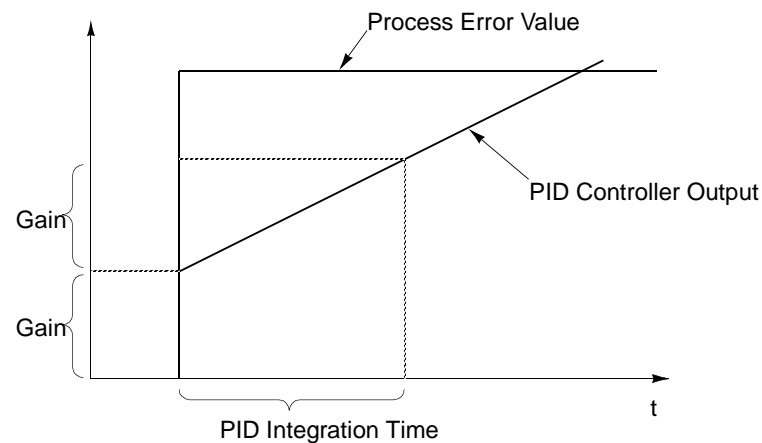

Figure 6-22 PID Controller Gain, I-Time, and Error Value.

**40.03 PID DERIV TIME** Derivative is calculated according to two consecutive error values ( $E_{K-1}$  and  $E_K$ ) according to the following formula:

$$\text{PID DERIV TIME} \cdot (E_K - E_{K-1})/T_S, \text{ in which } T_S = 12 \text{ ms sample time.}$$

For example, if there is a 10 % step in error value, the output of the PID Controller is increased by:

$$\text{PID DERIV TIME} \cdot 10 \% / T_S.$$

The derivative is filtered with a 1-pole filter. The time constant of the filter is defined by Parameter 40.04 PID DERIV FILTER.

**40.04 PID DERIV FILTER** Time constant of the 1-pole filter.

**40.05 ERROR VALUE INV** This parameter allows you to invert the Error Value (and thus the operation of the PID Controller). Normally, a decrease in Actual Signal (feedback) causes an increase in drive speed. If a decrease in Actual is desired to cause a decrease in speed, set Error Value Invert to YES.

**40.06 ACTUAL VALUE SEL** **ACT1; ACT1 - ACT2; ACT1 + ACT2; ACT1 \* ACT2; ACT1/ACT2; MIN(A1,A2) ; MAX(A1,A2); sqrt(A1-A2); sqA1 + sqA2**

Actual signal source for the PID Process Controller is selected by this parameter. The choice ACT1 sets one of the analogue inputs AI1, AI2 or AI3 as actual signal for the PID Controller. The setting of Parameter 40.07 ACTUAL 1 INPUT SEL determines the analogue inputs used. The setting of Parameter 40.08 ACTUAL 2 INPUT SEL determines the value of ACT2 which is used in selecting the Actual Value for the PID Controller together with ACT1. ACT1 and ACT2 are combined by subtraction, addition, multiplication or other functions as listed above.

In the list of parameter value choices A1 denotes ACT1 and A2 denotes ACT2. MIN(A1,A2) sets the parameter value to either ACT1 or ACT2, depending which one has the smallest value. sqrt(A1 - A2) sets the parameter value to square root of (ACT1 - ACT2). sqA1+sqA2 sets the parameter value to square root of ACT1 plus square root of ACT2.

Use the sqrt(A1 - A2) or sqA1+sqA2 function if the PID Controller controls flow with a pressure transducer measuring the pressure difference over a flow meter.

**40.07 ACTUAL 1 INPUT SEL** This parameter selects one of the analogue inputs as actual signal 1 e.g. ACT1 used in Parameter 40.06 ACTUAL VALUE SEL.

**AI1; AI2; AI3; AI5; AI6; CURRENT; TORQUE; POWER**

For connection of AI5 to AI6, see *Group 98 Option Modules*.

**40.08 ACTUAL 2 INPUT SEL** This parameter selects one of the analogue inputs as actual signal 2 e.g. ACT2 used in Parameter 40.06 ACTUAL VALUE SEL.

**AI1; AI2; AI3; AI5; AI6; CURRENT; TORQUE; POWER**

For connection of AI5 to AI6, see *Group 98 Option Modules*.

**40.09 ACT1 MINIMUM** Minimum value for Actual Value 1. Defined as % of the difference between the maximum and minimum values of the selected analogue input. The setting range is -1000 to +1000 %. Refer to Parameter

*Group 13 Analogue Inputs* for analogue input minimum and maximum settings.

The value of this parameter can be calculated using the formula below. The minimum of the actual value refers to the minimum of the span of the actual value.

$$\text{ACTUAL 1 MINIMUM} = \frac{\text{Minimum of actual value (V or mA)} - \text{MINIMUM AI (1, 2 or 3)}}{\text{MAXIMUM AI (1, 2 or 3)} - \text{MINIMUM AI (1, 2 or 3)}} \cdot 100 \%$$

For example: The pressure of a pipe system is to be controlled between 0 and 10 bar. The pressure transducer has an output span from 4 to 8 V for pressure between 0 and 10 bar. The minimum output voltage of the transducer is 2 V and the maximum 10 V, so the minimum and the maximum of the analogue input is set to 2 V and 10 V. ACTUAL 1 MINIMUM is calculated as follows:

$$\text{ACTUAL 1 MINIMUM} = \frac{4 \text{ V} - 2 \text{ V}}{10 \text{ V} - 2 \text{ V}} \cdot 100 \% = 25 \%$$

#### 40.10 ACT1 MAXIMUM

Maximum value for the Actual Value 1. Defined as % of the difference between the maximum and minimum values of the selected analogue input. The setting range is -1000 to +1000 %. Refer to Parameter *Group 13 Analogue Inputs* for analogue input minimum and maximum settings.

The value of this parameter can be calculated using the formula below. The maximum of the actual value refers to the maximum of the span of the actual value

$$\text{ACTUAL 1 MAXIMUM} = \frac{\text{Maximum of actual value (V or mA)} - \text{MINIMUM AI (1, 2 or 3)}}{\text{MAXIMUM AI (1, 2 or 3)} - \text{MINIMUM AI (1, 2 or 3)}} \cdot 100 \%$$

Refer to the description of the example at Parameter 40.09 ACT1 MINIMUM.

ACTUAL 1 MAXIMUM in this case is:

$$\text{ACTUAL 1 MAXIMUM} = \frac{8 \text{ V} - 2 \text{ V}}{10 \text{ V} - 2 \text{ V}} \cdot 100 \% = 75 \%$$

Figure 6-23 below shows three examples of actual value scaling.

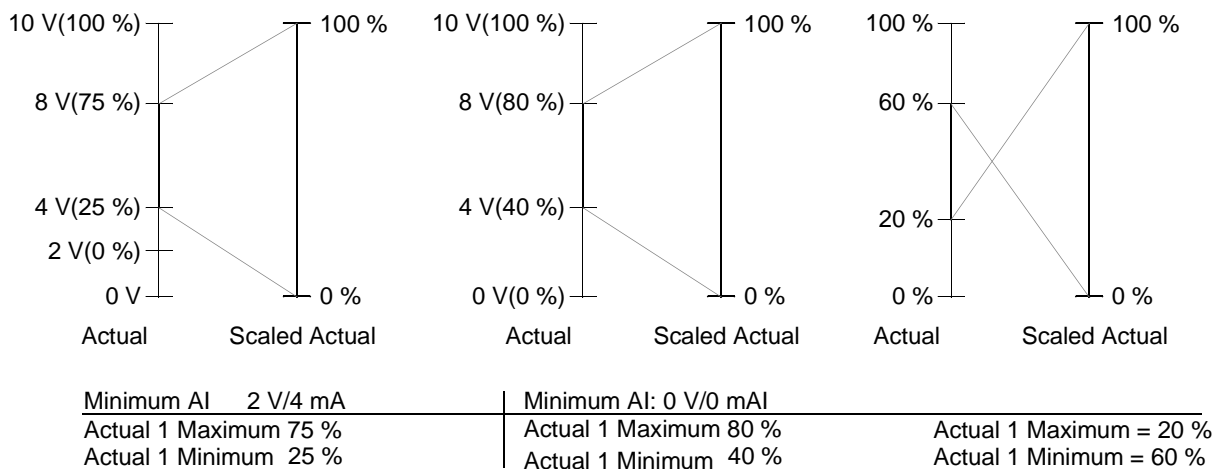

Figure 6-23 Actual Value Scaling.

40.11 ACT2 MINIMUM Refer to Parameter 40.09 ACT1 MINIMUM.

40.12 ACT2 MAXIMUM Refer to Parameter 40.10 ACT1 MAXIMUM.

40.13 PID INTEGRATION On/Off switch for the PID control block integrator.

**ON**

Integration is in use. This is the default value.

**OFF**

Integration is not used.

40.14 TRIM MODE Activates the trim function and selects between direct and proportional trimming. Not visible with 99.02 APPLICATION MACRO = PID CTRL. See subsection *Function Description: Reference Trimming*.

**OFF**

Trim function is not in use. This is the default value.

**PROPORTIONAL**

Trim function is in use. The trimming factor is relative to the external %-reference (EXT2).

**DIRECT**

Trim function is in use. The trimming factor is relative to a fixed limit used in the reference control loop (speed, frequency or torque).

40.15 TRIM REF SEL Selects the signal source for the trim reference. Not visible with 99.02 APPLICATION MACRO = PID CTRL. See subsection *Function Description: Reference Trimming* above.



**AI1; AI2; AI3; AI5; AI6;**

Analogue signal AI1 (to AI6) is used as the trim reference. AI1 is the default value. For the connection of AI5 to AI6, see *Group 98 Option Modules*.

**Example:** AI5 as a trim reference

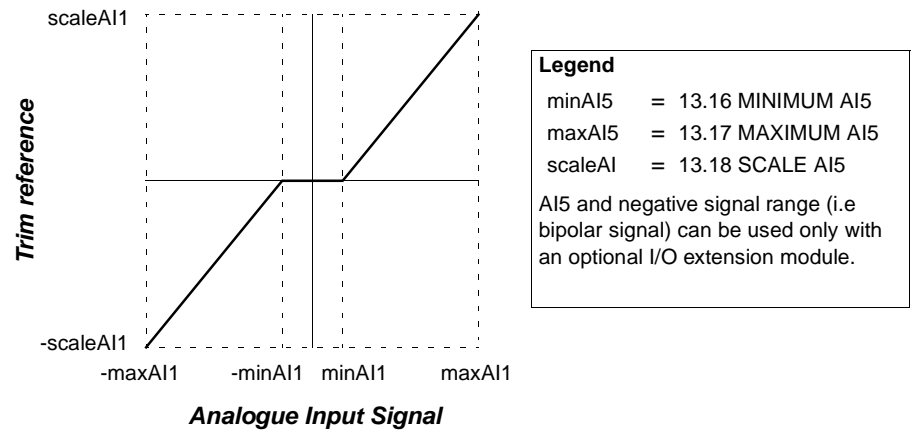
**PAR 40.16**

Value of Parameter 40.16 TRIM REFERENCE is used as the trim reference.

**40.16 TRIM REFERENCE**

Fixed trim reference value for the selector 40.15 TRIM REF SEL. Not visible with 99.02 APPLICATION MACRO = PID CTRL. See subsection *Function Description: Reference Trimming* above.

**-100.0% to 100.0%**

0.0% is the default value.

**40.17 TRIM RANGE ADJUST**

Multiplier for the PID control block output. Used in the trim function. Not visible with 99.02 APPLICATION MACRO = PID CTRL. See subsection *Function Description: Reference Trimming* above.

**-100.0% to 100.0%**

0.0% is the default value.

**40.18 TRIM SELECTION**

Selects whether the trimming is used for correcting the speed or torque reference. Visible only when 99.02 APPLICATION MACRO = T CTRL. See subsection *Function Description: Reference Trimming* above.

**SPEED TRIM**

Trimming is used for speed reference correction. This is the default value.

**TORQUE TRIM**

Trimming is used for torque reference correction.

**40.19 ACTUAL FILT TIME**

Filter time for the actual signals connected to the PID control block. See subsection *Function Description: Process PID Control* above.

**0.04 s to 10.00 s**

**40.20 SLEEP SELECTION** Sets the sleep activation criteria. See subsection *Function Description: Sleeping* above. Visible only with 99.02 APPLICATION MACRO = PID CTRL.

**OFF**

The sleep function is not active. This is the default value.

**INTERNAL**

The Sleep function is activated and deactivated as defined with Parameters 40.21 SLEEP LEVEL, and 40.23 WAKE UP LEVEL.

**DI1; ...; DI12**

Digital input must be on (“1”) to enter the sleep mode. The sleep delay, set with Parameter 40.22 SLEEP DELAY, is in effect. For connection of DI7 to DI12, see *Group 98 Option Modules*.

**40.21 SLEEP LEVEL** Sets the speed limit for the sleep function. See subsection *Function Description: Sleeping* above. Visible only with 99.02 APPLICATION MACRO = PID CTRL.

**0.0 to 7200.0 rpm**

The default value is 0.0 rpm. When the motor speed falls below the sleep level, the sleep delay counter is started. When the motor speed exceeds the sleep level the sleep delay counter is reset.

**40.22 SLEEP DELAY** Sets the delay for the sleep function. See the figures in subsection *Function Description: Sleeping* above. Visible only with 99.02 APPLICATION MACRO = PID CTRL.

**0.0 s to 3600.0 s**

The default value is 0.0 s. If the motor speed is below a set level (40.21 SLEEP LEVEL) longer than the sleep delay, the ACS 600 is stopped, and the control panel shows the warning message “SLEEP MODE”.

**40.23 WAKE UP LEVEL** Sets the process actual value limit for the sleep function. See the figures in subsection *Function Description: Sleeping* above. Visible only with 99.02 APPLICATION MACRO = PID CTRL.

**0.0% to 100.0%**

The default value is 0.0%. When the process actual value falls below the limit, the wake-up counter starts. The wake-up level is defined in percents of the used process reference value.

**40.24 WAKE UP DELAY** Sets the wake-up delay for the sleep function. See subsection *Function Description: Reference Trimming* above. Visible only with 99.02 APPLICATION MACRO = PID CTRL.

**0.0 s to 3600.0 s**

The default value is 0.0 s. The drive wakes up if the process actual value is below a set level (40.23 WAKE UP LEVEL) longer than the wake-up delay.

**Group 42 Brake Control** Group 42 includes parameters for the brake control function. The function operates on a 100 ms time level.

The mechanical brake is used for holding the motor and driven machinery at zero speed when the drive is stopped, or when the drive is not powered.

*Table 6-26 Group 42.*

Parameter	Range/Unit	Description
1 BRAKE CTRL	OFF; ON	Brake control function on/off
2 BRAKE ACKNOWLEDGE	OFF; DI5; DI6; DI11; DI12	Interface for the brake acknowledge signal
3 BRAKE OPEN DELAY	0.0 to 5.0 s	Brake open delay
4 BRAKE CLOSE DELAY	0.0 to 60.0 s	Brake close delay
5 ABS BRAKE CLS SPD	0 to 1000 rpm	Absolute brake close speed
6 BRAKE FAULT FUNC	FAULT; WARNING	Brake fault function
7 STRT TORQ REF SEL	NO; AI1; AI2; AI3; AI5; AI6; PAR 42.08	Starting torque signal source
8 START TORQ REF	-300 to 300%	Starting torque setting

**Brake Control Function Description**



The figure below shows a brake control application example.

**WARNING!** Make sure the machinery into which the ACS 600 with brake control function is integrated fulfils the personnel safety regulations. Note that the frequency converter (a Complete Drive Module or a Basic Drive Module, as defined in IEC 61800-2), is not considered as a safety device mentioned in the European Machinery Directive and related harmonised standards. Thus the personnel safety of the complete machinery must not be based on a specific frequency converter feature (such as the brake control function), but it has to be implemented as defined in the application specific regulations.

**Summary**

- brake on/off control through relay output RO1
- brake supervision through digital input DI5 (optional)
- fixed starting torque at brake release
- emergency brake switch in the brake control circuit

**Parameter Settings**

14.01 RELAY RO1 OUTPUT	BRAKE CTRL
42.01 BRAKE CTRL	ON
42.02 BRAKE ACKNOWLEDGE	DI5
42.03 BRAKE OPEN DELAY	<i>Brake specific</i>
42.04 BRAKE CLOSE DELAY	<i>Brake specific</i>
42.05 ABS BRAKE CLS SPD	<i>Application specific</i>
42.06 BRAKE FAULT FUNC	FAULT
42.07 STRT TORQ REF SEL	Par 42.08
42.08 START TORQ REF	100%

**Actual values**

3.12 FAULT WORD 3, 3.16 ALARM WORD 3
--------------------------------------

**Fault / Warning messages** (See Chapter 7 – Fault Tracing)

BRAKE ACKN
------------

**Wirings**

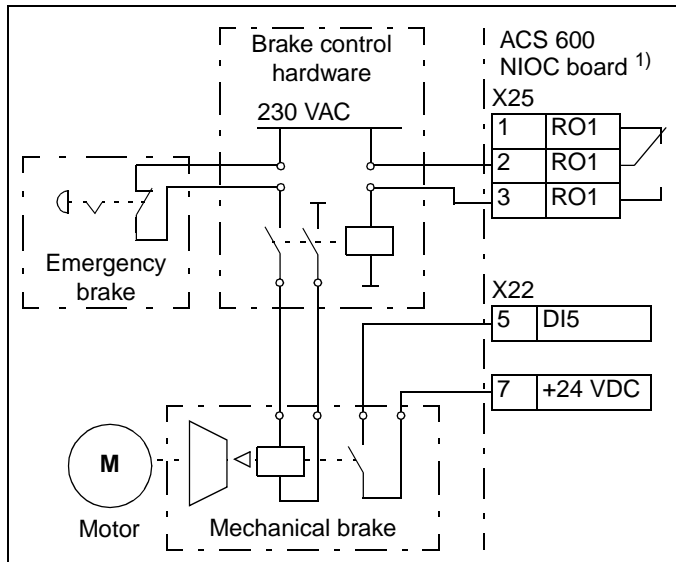

The time scheme below illustrates the operation of the brake control function. See also the state machine on the following page.

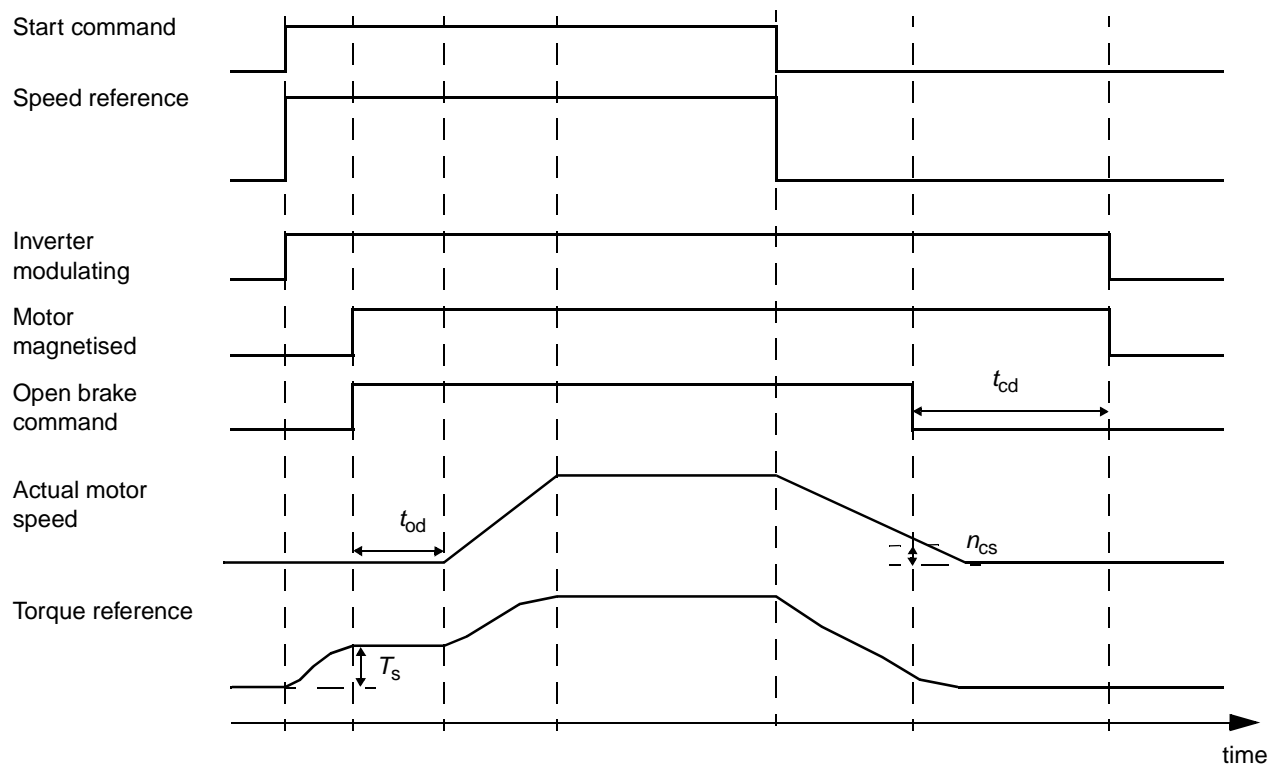

- |          |  |
|----------|--|
| $T_s$    | Start torque at brake release: See 42.07 STRT TORQ REF SEL and 42.08 START TORQ REF. |
| $t_{od}$ | Brake open delay: See 42.03 BRAKE OPEN DELAY.  |
| $n_{cs}$ | Brake close speed: See 42.05 ABS BRAKE CLS SPD.                                      |
| $t_{cd}$ | Brake close delay: See 42.04 BRAKE CLOSE DELAY.                                      |

The figure below is the state machine for the brake control function.

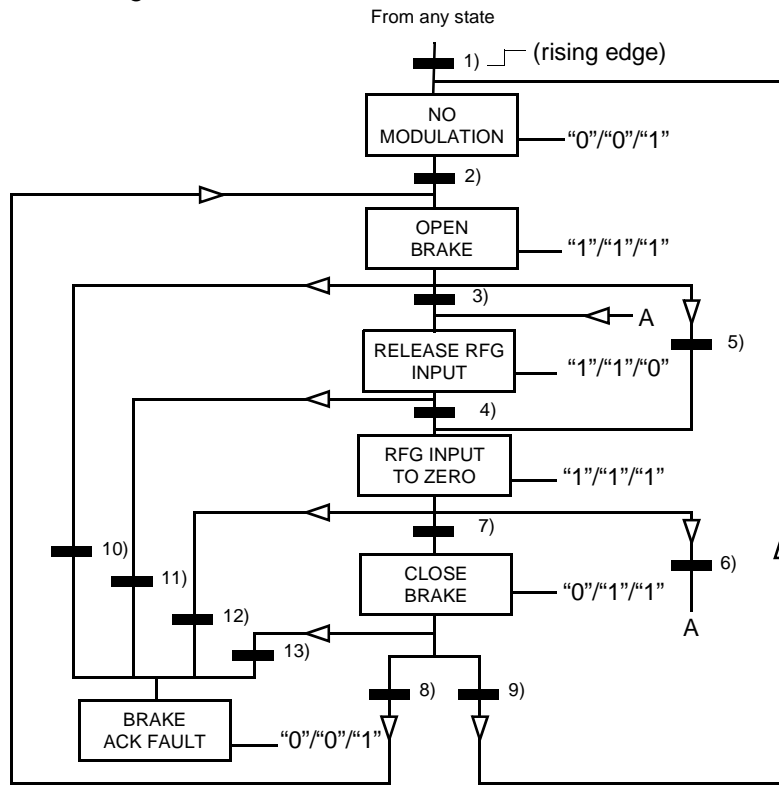

RFG = Ramp Function Generator. Used in the reference handling in the speed control loop.



**Brake control function state**

- NN: State name
- X/Y/Z: State outputs/operations
  - X = "1" Open the brake. The relay output set to brake on/off control energises.
  - Y = "1" Forced start. The function keeps the internal Start on until the brake is closed in spite of the status of the external Start signal.
  - Z = "1" Ramp in zero. Forces the used speed reference to zero along a ramp.

**State change conditions**

- 1) Brake control active "0" -> "1" OR Inverter is modulating ="0"
  - 2) Motor magnetised = "1" AND Drive running = "1"
  - 3) Brake acknowledgement = "1" AND Brake open delay passed AND Start = "1"
  - 4) Start = "0"
  - 5) Start = "0"
  - 6) Start = "1"
  - 7) |Actual motor speed| < Brake close speed AND Start = "0"
  - 8) Start = "1"
  - 9) Brake acknowledgement = "0" AND Brake close delay passed ="1" AND Start = "0"
- Only if Parameter 42.02 BRAKE ACKNOWLEDGE ≠ OFF:
- 10) Brake acknowledgement = "0" AND Brake open delay passed ="1"
  - 11) Brake acknowledgement = "0"
  - 12) Brake acknowledgement = "0"
  - 13) Brake acknowledgement = "1" AND Brake close delay passed ="1"

- 42.01 BRAKE CTRL** Activates the brake control function.
- OFF**  
Off is the default value: Brake control function is not in use.
- ON**  
Brake control function is on.
- 42.02 BRAKE ACKNOWLEDGE** Activates the external brake on/off supervision and selects the source for the signal. The use of the external on/off supervision signal is optional.
- OFF**  
External brake on/off supervision is not in use. This is the default value.
- DI5**  
Brake on/off supervision is in use. Digital input DI5 is the signal source. DI5 = “1”: Brake is open. DI5 = “0”: Brake is closed. The connection is shown in the subsection *Brake Control Function Description* above.
- DI6; DI11; DI12**  
See DI5. For connection of DI11 and DI12, see *Group 98 Option Modules*.
- 42.03 BRAKE OPEN DELAY** See the operation diagrams in subsection *Brake Control Function Description* above: The delay counter starts after the motor is magnetised. The brake control function simultaneously energises the ACS 600 relay output, and the brake starts opening. During the delay, the drive rises the motor torque to level required at the brake release (= Parameters 42.07 STRT TORQ REF SEL and 42.08 START TORQ REF).
- 0.0 to 5.0 s**  
The default value is zero. Set the delay the same as the mechanical opening delay of the brake given by the brake manufacturer.
- 42.04 BRAKE CLOSE DELAY** See the operation diagrams in subsection *Brake Control Function Description* above: The delay counter starts when the motor actual speed has fallen below the set level after the drive has received the stop command (= Parameter 42.05 ABS BRAKE CLS SPD). Simultaneously with the counter start, the brake control function de-energises the relay output, and the brake starts closing. During the delay, the brake function keeps the motor live preventing the motor speed from falling below zero.
- 0.0 to 60.0 s**  
The default value is zero. Set the delay the same as the mechanical make up time of the brake (= operating delay when closing) given by the brake manufacturer.
- 42.05 ABS BRAKE CLS SPD** See Parameter 42.04 BRAKE CLOSE DELAY and the operation diagrams in subsection *Brake Control Function Description* above.  
**Note:** This is an absolute value.

- 0 to 1000 rpm**  
Default value is 100 rpm.
- 42.06 BRAKE FAULT FUNC** Defines how the drive reacts in case the status of the external brake acknowledge signal does not meet the status expected by the brake control function. See the state machine in subsection *Brake Control Function Description* above.
- FAULT**  
Brake control function generates a fault. The drive trips and a fault message is shown on the control panel display. The fault is also saved in the event log.
- WARNING**  
Brake control function generates a warning. The drive continues operation and a warning message is shown on the control panel display. The warning is also saved in the event log.
- 42.07 STRT TORQ REF SEL** Selects the source for the motor starting torque reference. See the operation diagrams in subsection *Brake Control Function Description* above.
- NO**  
No source for the starting torque. This is the default value.
- AI1; AI2; AI3; AI5; AI6**  
Starting torque reference is given through an analogue input. For the connection of AI5 and AI6, see *Group 98 Option Modules*.
- PAR 42.08**  
Starting torque reference is given by Parameter 42.08 START TORQ REF.
- 42.08 START TORQ REF** Sets the motor starting torque at brake release in percent of the motor nominal torque. See the operation diagrams in subsection *Brake Control Function Description* above.
- 300 to 300 %**  
Default value is 0.



**Group 45 Function Selection**

Group 45 includes parameters for six pointers. The user can select any drive status information for a pointer and direct the value to a relay output.

Table 6-27 Group 45.

Parameter	Range/Value	Description
45.01 POINTER1 GRP+IND	-9999 to 9999	Index selector for pointer 1
45.02 POINTER1 BIT	0 to 15	Bit selector for pointer 1
45.03 POINTER2 GRP+IND	-9999 to 9999	Index selector for pointer 2
45.04 POINTER2 BIT	0 to 15	Bit selector for pointer 2
45.05 POINTER3 GRP+IND	-9999 to 9999	Index selector for pointer 3
45.06 POINTER3 BIT	0 to 15	Bit selector for pointer 3
45.07 POINTER4 GRP+IND	-9999 to 9999	Index selector for pointer 4
45.08 POINTER4 BIT	0 to 15	Bit selector for pointer 4
45.09 POINTER5 GRP+IND	-9999 to 9999	Index selector for pointer 5
45.10 POINTER5 BIT	0 to 15	Bit selector for pointer 5
45.11 POINTER6 GRP+IND	-9999 to 9999	Index selector for pointer 6
45.12 POINTER6 BIT	0 to 15	Bit selector for pointer 6

The figure below shows how to indicate drive status “READY TO OPERATE” through the relay output RO1.

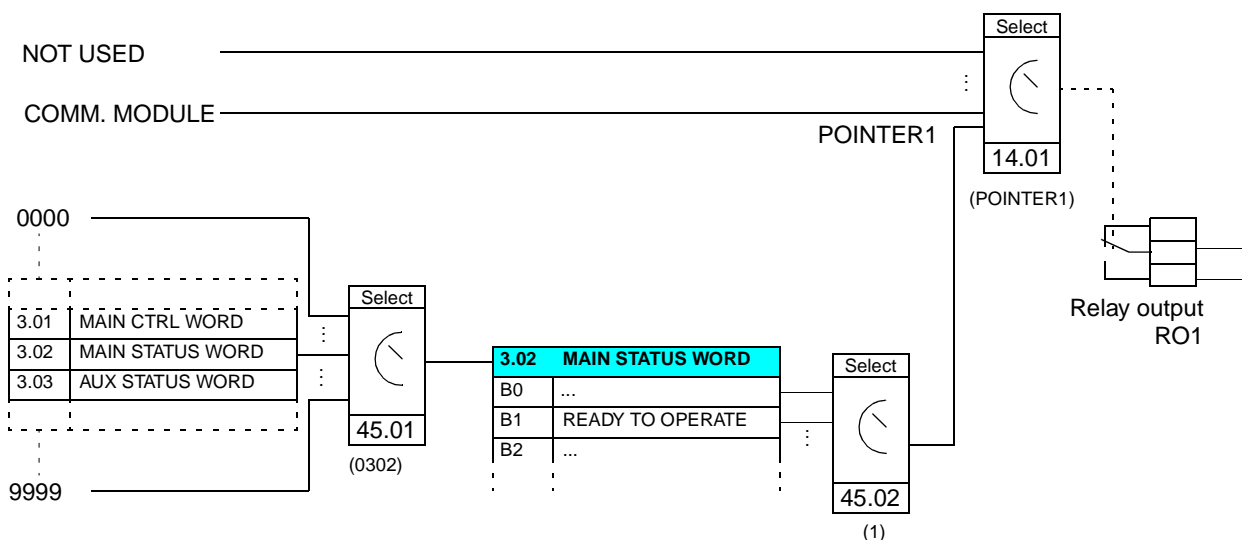

- 45.01 POINTER1 GRP+IND** Parameter index selector for pointer 1. See the figure above.  
**-9999 to 9999**  
Default value is 0000. The negative range is reserved for the signal inversion.  
**Example** (see the figure above): If 45.01 POINTER1 GRP+IND has the value -0302, the output of selector 45.02 POINTER1 BIT is inverted. In other words, the pointer output has value “0” when status bit B1 “READY TO OPERATE” has the value “1” and vice versa.
- 45.02 POINTER1 BIT** Bit selector for the pointer 1. See the figure above.  
**0 to 15**  
Default value is 0 (bit no. 0).
- 45.03 POINTER2 GRP+IND** See Parameter 45.01 POINTER1 GRP+IND.
- 45.04 POINTER2 BIT** See Parameter 45.02 POINTER1 BIT.
- 45.05 POINTER3 GRP+IND** See Parameter 45.01 POINTER1 GRP+IND.
- 45.06 POINTER3 BIT** See Parameter 45.02 POINTER1 BIT.
- 45.07 POINTER4 GRP+IND** See Parameter 45.01 POINTER1 GRP+IND.
- 45.08 POINTER4 BIT** See Parameter 45.02 POINTER1 BIT.
- 45.09 POINTER5 GRP+IND** See Parameter 45.01 POINTER1 GRP+IND.
- 45.10 POINTER5 BIT** See Parameter 45.02 POINTER1 BIT.
- 45.11 POINTER6 GRP+IND** See Parameter 45.01 POINTER1 GRP+IND.
- 45.12 POINTER6 BIT** See Parameter 45.02 POINTER1 BIT.

**Group 50 Encoder Module**

These parameters are visible, and need to be adjusted, only when a pulse encoder module (optional) is installed and activated with Parameter 98.01 ENCODER MODULE.

The parameters in Group 50 define the encoder signal decoding and the operation of the ACS 600 in encoder or NTAC module fault conditions.

These parameter settings will remain the same even though the application macro is changed.

Table 6-28 Group 50 parameters.

Parameter	Range	Description
50.01 PULSE NR	0 ... 29999	Number of encoder pulses per revolution.
50.02 SPEED MEAS MODE	A <sub>+</sub> B DIR ; A <sub>-</sub> ; A <sub>-</sub> B DIR ; A <sub>+</sub> B <sub>-</sub>	Calculation of encoder pulses.
50.03 ENCODER FAULT	WARNING; FAULT	Operation of the ACS 600 if an encoder failure or encoder communication failure is detected.
50.04 ENCODER DELAY	5 ... 50000 ms	Delay for the encoder supervision function (See Parameter 50.03 ENCODER FAULT)
50.05 ENCODER CHANNEL	CHANNEL1, CHANNEL 2	Channel from which the Standard Application Program reads the signals of the Pulse Encoder Module (NTAC).
50.06 SPEED FB SEL	INTERNAL; ENCODER	Selects the speed feedback value used in the control; Speed estimate or measured speed.

**50.01 PULSE NR** This parameter states the number of the encoder pulses per one revolution.

**50.02 SPEED MEAS MODE** This parameter defines how the encoder pulses are calculated.

**A<sub>+</sub>B DIR**

Ch A: positive edges calculated for speed.

Ch B: direction.

**A<sub>-</sub>**

Ch A: positive and negative edges calculated for speed.  
Ch B: not used.

**A<sub>-</sub>B DIR**

Ch A: positive and negative edges are calculated for speed.  
Ch B: direction.

**A -- B --**

All edges of the signals are calculated.

**50.03 ENCODER FAULT**

This parameter defines the operation of the ACS 600 if a failure is detected in communication between the pulse encoder and the Pulse Encoder Interface Module (NTAC) or in between the NTAC module and the ACS 600.

Encoder supervision function activates if either of the following conditions is valid:

1. There is a 20 % difference between the estimated speed and the measured speed received from the encoder.
2. No pulses are received from the encoder within defined time (see Parameter 50.04 ENCODER DELAY), and the motor torque is at the allowed maximum value.

**WARNING**

Warning indication is generated.

**FAULT**

Fault indication is generated and the ACS 600 stops the motor.

**50.04 ENCODER DELAY**

This is the time delay for the encoder supervision function (See Parameter 50.03 ENCODER FAULT).

**50.05 ENCODER CHANNEL**

This parameter defines the fibre optic channel of the control board from which the Standard Application Program reads the signals coming from the Pulse Encoder Interface Module (NTAC).

**CHANNEL 2**

Pulse Encoder Module (NTAC) signals are read from channel 2 (CH2). This is the default value. It can be used in most cases.

**CHANNEL 1**

Pulse Encoder Module (NTAC) signals are read from channel 1 (CH1). The Pulse Encoder Module (NTAC) must be connected to CH1 instead of CH2 in applications where CH2 is reserved by a Master station (e.g. a Master/Follower application). This parameter value must be changed accordingly. See also Parameter 70.03 CH1 BAUDRATE.

**50.06 SPEED FB SEL**

This parameter defines the speed feedback value used in control.

**INTERNAL**

Calculated speed estimate is used as the speed feedback.

**ENCODER**

Actual speed measured with an encoder is used as the speed feedback.

**Group 51  
Communication Module**

These parameters are visible, and need to be adjusted, only when a fieldbus adapter module (optional) is installed and activated with Parameter 98.02 COMM. MODULE LINK. For details on the parameters, refer to the manual of the fieldbus module.

These parameter settings will remain the same even though the macro is changed.

**Group 52 Standard  
Modbus**

These parameters define the basic settings for the Standard Modbus Link. See *Appendix C – Fieldbus Control*.

*Table 6-29 Group 52 parameters.*

Parameter	Range	Description
52.01 STATION NUMBER	1 to 247	Device address. Two units with the same addresses are not allowed on-line. Default value is 1.
52.02 BAUDRATE	600; 1200; 2400; 4800; 9600	Transfer rate of the link in bit/s. Default value is 9600.
52.03 PARITY	NONE1STOPBIT; NONE2STOPBIT; ODD; EVEN	Usage of parity bit(s). Default value is ODD.

**Group 60  
MASTER/FOLLOWER**

The Master/Follower group includes parameters needed when the system is run by several ACS 600 drives and the motor shafts are coupled to each other via gearing, chain, belt etc.

This section contains a brief introductory to Master/Follower application and the parameter descriptions. For more information see the separate *Master/Follower Application Guide* (EN code: 58962180).

Table 6-30 Group 60 parameters.

Parameter	Range	Description
60.01 MASTER LINK MODE	NOT IN USE; MASTER; FOLLOWER	Sets the Master/Follower communication mode for the station
60.02 TORQUE SELECTOR	SPEED;TORQUE; MINIMUM; MAXIMUM; ADD; ZERO	Follower torque reference selector
60.03 WINDOW SEL ON	NO; YES	Window function activation
60.04 WINDOW WIDTH POS	0 to 1500	Window limit for the positive speed error
60.05 WINDOW WIDTH NEG	0 to 1500	Window limit for the negative speed error
60.06 DROOP RATE	0 to 100%	Droop rate as a percent of the maximum speed
60.07 MASTER SIGNAL 2	0000 to 9999	Addres from which Master reads Reference 1
60.08 MASTER SIGNAL 3	0000 to 9999	Addres from which Master reads Reference 2

**Function Description:** The figures below illustrate the Master/Follower function in brief.  
**Master/Follower**

In Master/Follower communication, the Master station cyclically sends a message to the Follower stations. The message is read by all on-line Follower stations through channel CH2. The drive behaviour depends on the settings of Group 60 Parameters and Parameters 10.01 EXT1 STRT/STP/DIR, 10.02 EXT2 STRT/STP/DIR, 11.03 EXT REF1 SELECT, 11.06 EXT REF2 SELECT, 16.01 RUN ENABLE and 16.04 FAULT RESET SEL.

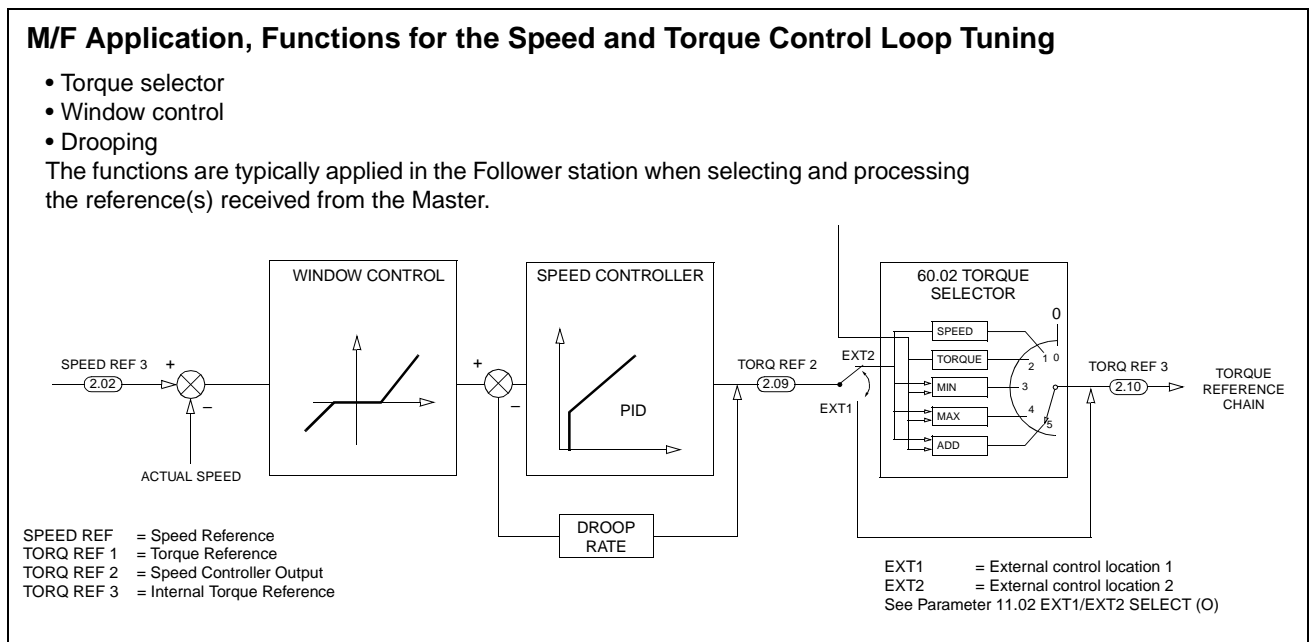
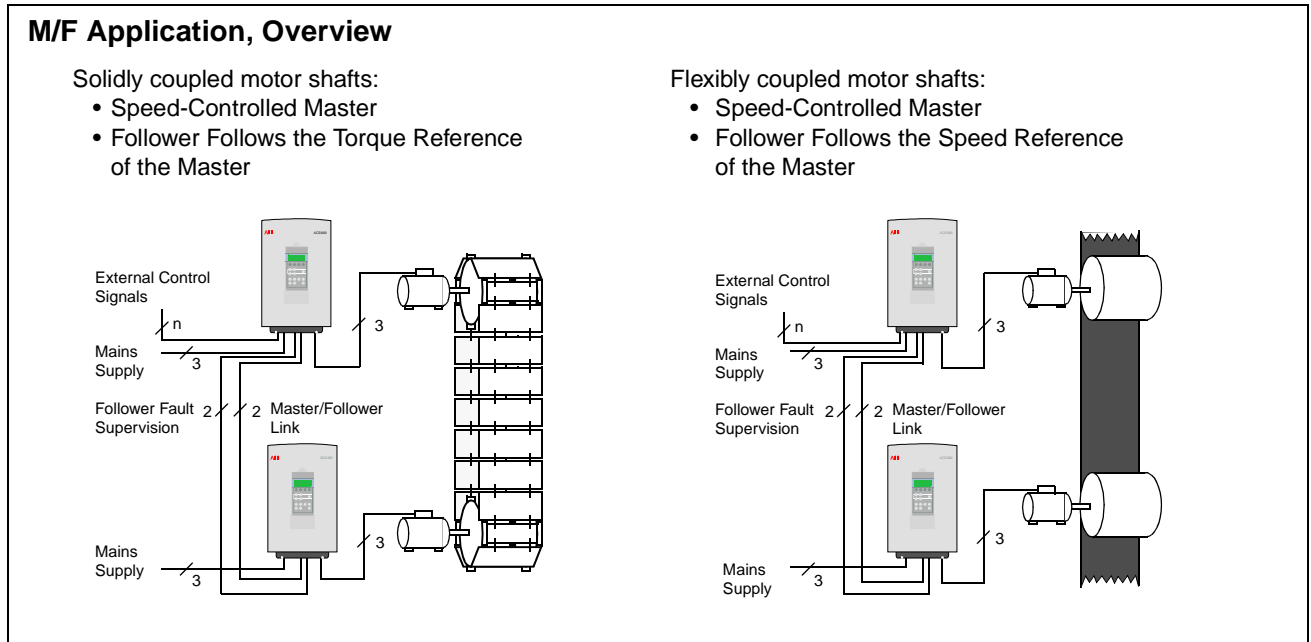

### M/F Application, Window Control

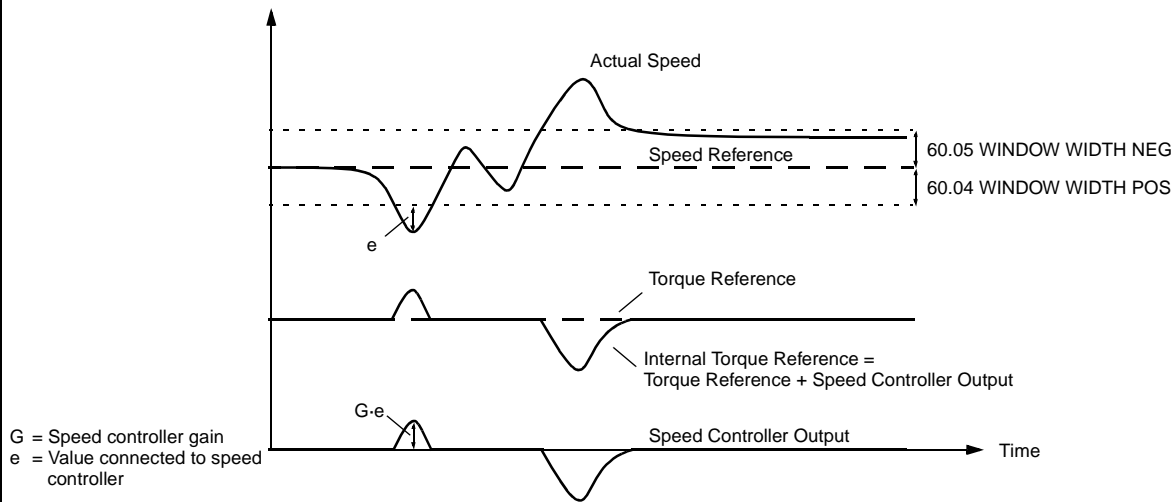

**Example 1: Window Control Off in a Load Loss Condition**

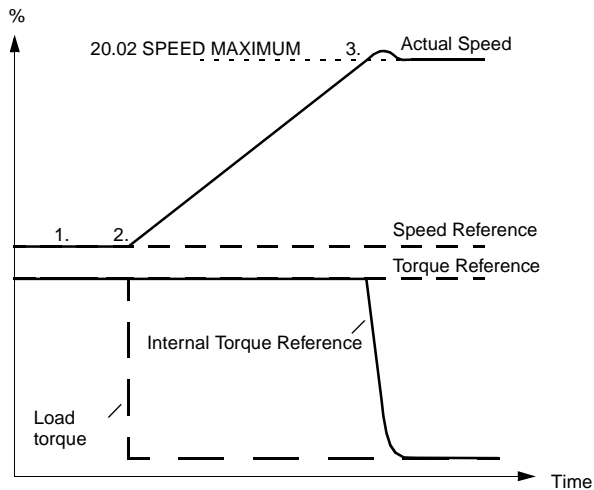

The Follower drive is torque-controlled. Parameter 11.02 EXT1/EXT2 SELECT is set to EXT2 and 60.02 TORQUE SELECTOR to TORQUE.

1. Normal operating range. The Follower is controlled by torque reference of the Master.
2. Load loss occurs. Follower actual speed starts to rise.
3. The speed increases until the maximum speed limit of the ACS 600 is reached (Parameter 20.02 MAXIMUM SPEED). Internal torque reference is restricted to stop the speed increase.

**Example 2: Window Control On in a Load Loss Condition**

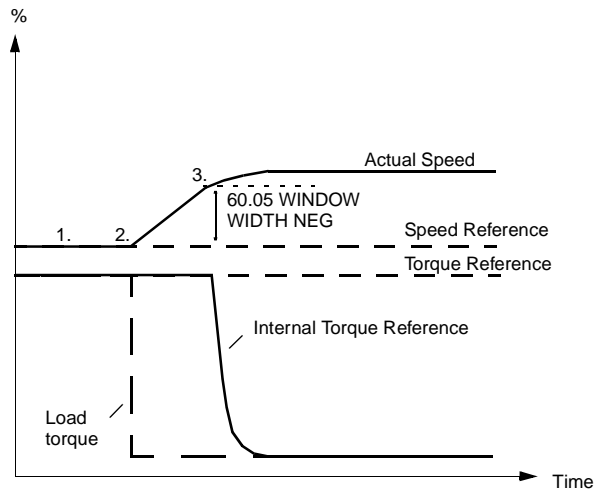

The Follower drive is torque-controlled. Parameter 11.02 EXT1/EXT2 SELECT is set to EXT2 and 60.02 TORQUE SELECTOR to ADD.

1. Normal operating range. Window Control keeps the speed controller input zero. The Follower is controlled by torque reference of the Master.
2. Load loss occurs. Follower actual speed starts to rise.
3. The speed increases until the absolute value of the negative speed error exceeds WINDOW WIDTH NEG. Window Control connects the value outside the window to the speed controller. Negative speed controller output value is produced and added to torque reference received from the Master. Internal torque reference is restricted to stop the speed increase.



- 60.01 MASTER LINK MODE** This parameter determines the role of the drive on the Master/Follower link.
- NOT IN USE**  
The Master/Follower link is not active. This the default value.
- MASTER**  
The drive acts as the Master station.
- FOLLOWER**  
The drive acts as a Follower station.
- 60.02 TORQUE SELECTOR** Selects the reference used in motor torque control. Typically, the value needs to be changed only in the Follower station(s). See subsection *Function Description: Master/Follower* above.
- The parameter is visible only when Parameter 99.02 APPLICATION MACRO is T CTRL. External control location 2 (EXT2) must be active to enable torque selector.
- SPEED**  
The follower speed controller output is used as a reference for motor torque control. The drive is speed controlled.
- SPEED can be used both in the Follower and the Master if
- the motor shafts of the Master and Follower are connected flexibly. (A slight speed difference between the Master and the Follower is possible/allowed.)
  - drooping is used (see Parameter 60.06 DROOP RATE).
- TORQUE**  
This is the default value. The drive is torque-controlled.
- The selection is used in the Follower(s) when the motor shafts of the Master and Follower are coupled solidly to each other by gearing, a chain or other means of mechanical power transmission and no speed difference between the drives is allowed or possible.

---

**Note:** If TORQUE is selected, the ACS 600 does not restrict the speed variation as long as the speed is within the limits defined with Parameters 20.01 MINIMUM SPEED and 20.02 MAXIMUM SPEED. More definite speed supervision is often needed. In those cases, the selection ADD should be used instead of TORQUE.

---

#### **MINIMUM**

The torque selector compares the torque reference and the speed controller output, the smaller of which is used as the reference for the motor torque control. MINIMUM is selected in special cases only.

#### **MAXIMUM**

The torque selector compares the torque reference and the speed controller output, the greater of which is used as the reference for the motor torque control. MAXIMUM is selected in special cases only.

#### **ADD**

The torque selector adds the speed controller output to the torque reference. The drive is torque controlled in the normal operating range.

The selection ADD, together with the window control, forms a speed supervision function for a torque controlled Follower drive as follows:

- In the normal operating range, the Follower follows the torque reference of the Master (TORQ REF 1).
- Window control keeps the speed controller input and output at zero as long as the speed error (speed reference - actual speed) remains within the parameter-set window.
- If the speed error moves out of the window, window control connects the error to the speed controller. The speed controller output increases or decreases the internal torque reference, stopping the change of the actual speed.

#### **ZERO**

This selection forces the output of the torque selector to zero.

- 60.03 WINDOW SEL ON** The window control is visualised in the subsection *Function Description: Master/Follower* above. Window control, together with selection ADD at Parameter 60.02 TORQUE SELECTOR, forms a speed supervision function for a torque controlled drive.
- The parameter is visible only when Parameter 99.02 APPLICATION MACRO is T CTRL. External control location 2 (EXT2) must be active to enable window control.
- NO**  
Window control is off. This is the default value.
- YES**  
Window control is on. Selection YES is used only when Parameter 60.02 TORQUE SELECTOR is ADD. Window control supervises the speed error value (Speed Reference - Actual Speed). In the normal operating range, window control keeps the speed controller input at zero. The speed controller is evoked only if:
- the speed error exceeds the value of Parameter 60.04 WINDOW WIDTH POS or
  - the absolute value of the negative speed error exceeds the value of Parameter 60.05 WINDOW WIDTH NEG.
- When the speed error moves outside the window, the exceeding part of the error value is connected to the speed controller. The speed controller produces a reference term relative to the input and gain of the speed controller (Parameter 23.01 GAIN) which the torque selector adds to torque reference. The result is used as the internal torque reference for the ACS 600.
- Example:** In a load loss condition, the internal torque reference of the drive is decreased to prevent an excessive rise of the motor speed. If window control were inactivated, the motor speed would rise until a speed limit of the ACS 600 were reached. (Parameters 20.01 MINIMUM SPEED and 20.02 MAXIMUM SPEED define the speed limits.)
- 60.04 WINDOW WIDTH POS** See Parameter 60.03 WINDOW SEL ON. The parameter is visible only when Parameter 99.02 APPLICATION MACRO is T CTRL.
- 0 to 1500 rpm**  
The default value is 0.
- 60.05 WINDOW WIDTH NEG** See Parameter 60.03 WINDOW SEL ON. The parameter is visible only when Parameter 99.02 APPLICATION MACRO is T CTRL.
- 0 to 1500 rpm**  
The default value is 0.
- 60.06 DROOP RATE** This parameter value needs to be changed only if both the Master and the Follower are speed-controlled:
- External control location 1 (EXT1) is selected (see Parameter 11.02 EXT 1/EXT 2 SELECT, or

- External control location 2 (EXT2) is selected (see Parameter 11.02 EXT 1/EXT 2 SELECT) and Parameter 60.02 TORQUE SELECTOR is set to SPEED.

The default value is 0%.

The drooping prevents conflict between the Master and Follower by allowing a slight speed difference between them.

The correct droop rate for a process must be found out case by case in practice. The droop rate needs to be set both for the Master and the Follower.

The droop rate is set in % of the motor nominal speed. The actual speed decrease at a certain operating point depends on the droop rate setting and the drive load (= torque reference / speed controller output). The drooping slightly decreases the drive speed as the drive load increases. At 100% speed controller output, drooping is at its nominal level, i.e. equal to the value of the DROOP RATE. The drooping effect decreases linearly to zero along with the decreasing load.

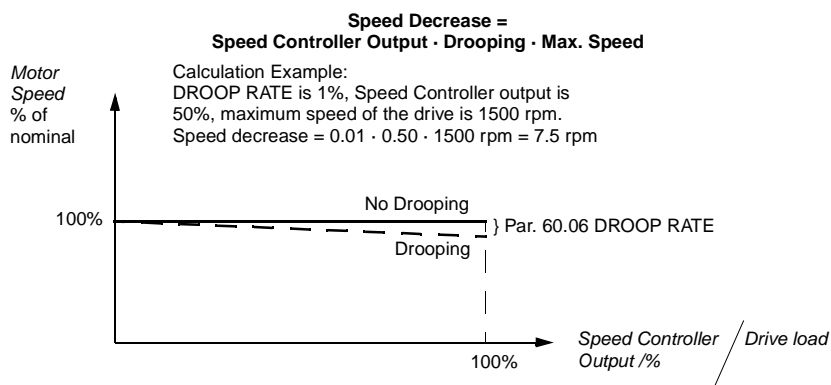

**60.07 MASTER SIGNAL 2**

This parameter selects the signal that is sent by the Master to the Follower(s) as *Reference 1* (speed reference). See the separate *Master/Follower Application Guide* (English code: 58962180).

The format is as follows: **(x)xyy**, where **(x)x** = Actual Signal or Parameter Group, **yy** = Actual Signal or Parameter Index.

The default value is **202**, which denotes Actual Signal Group 2, Index 02, i.e. 2.02 SPEED REF 3.

**60.08 MASTER SIGNAL 3**

This parameter selects the signal that is sent by the Master to the Follower(s) as *Reference 2* (torque reference). See the separate *Master/Follower Application Guide* (EN code: 58962180).

The format is as follows: **(x)xyy**, where **(x)x** = Actual Signal or Parameter Group, **yy** = Actual Signal or Parameter Index.

The default value is **213**, which denotes Actual Signal Group 2, Index 13, i.e. 2.13 TORQ REF USED.

**Group 70 DDCS Control** The ACS 600 can communicate with external equipment via a DDCS protocol serial communication channels. The parameters in Group 70 set the ACS 600 node addresses for the DDCS channels.

These parameter values need to be adjusted only in certain special cases, examples of which are given in the table below.

Table 6-31 Group 70 parameters.

Parameter	Range	Description
70.01 CHANNEL 0 ADDR	1 ... 125	Node address for CH0. There must not be two nodes with the same address on-line. The setting needs to be changed when a master station is connected to CH0 and it does not automatically change the address of the slave. Examples of such masters are an ABB Advant Controller AC 70 or another ACS 600.
70.02 CHANNEL 3 ADDR	1 ... 254	Node address for CH3. There must not be two nodes with the same address on-line. Typically the setting needs to be changed when ACS 600 is connected to a ring which consists of several ACS 600s and a PC with the DriveWindow® program running.
70.03 CH1 BAUDRATE	8; 4; 2; 1 MBITS	The communication speed of the fibre optic channel 1. Typically the setting needs to be changed only if the Pulse Encoder Module (NTAC) is connected to CH1 instead of CH2. Then the speed must be changed to 4 Mbits. See also Parameter 50.05 ENCODER CHANNEL.

**Group 90 D SET REC ADDR**

These parameters are visible, and can be adjusted, only when a fieldbus communication is activated with Parameter 98.02 COMM. MODULE LINK.

Table 6-32 Group 90 parameters.

Parameter	Range	Description
90.01 AUX DS REF3	0 ... 8999	These parameters enable parameter adjustment through the fieldbus reference. See <i>Appendix C – Fieldbus Control</i> .
90.02 AUX DS REF4	0 ... 8999	
90.03 AUX DS REF5	0 ... 8999	
90.04 MAIN DS SOURCE	1 ... 255	Defines the data set number from which the drive reads the Control Word, Reference REF1 and Reference REF2. See <i>Appendix C – Fieldbus Control</i> .
90.05 AUX DS SRCE	1 ... 255	Defines the data set number from which the drive reads the References REF3, REF4 and REF5. See <i>Appendix C – Fieldbus Control</i> .

**Group 92 D SET TR ADDR**

These parameters are visible, and can be adjusted, only when a fieldbus communication is activated with Parameter 98.02 COMM. MODULE LINK

Table 6-33 Group 92 parameters.

Parameter	Range	Description
92.01 MAIN DS STATUS WORD	302 (fixed, not visible)	These parameters define the Main and Auxiliary Actual signal data sets, sent by the ACS 600 to the fieldbus master station. See <i>Appendix C – Fieldbus Control</i> .
92.02 MAIN DS ACT1	0 ... 9999	
92.03 MAIN DS ACT2	0 ... 9999	
92.04 AUX DS ACT3	0 ... 9999	
92.05 AUX DS ACT4	0 ... 9999	
92.06 AUX DS ACT5	0 ... 9999	

**Group 96 EXTERNAL  
AO**

These parameters are visible, and can be adjusted, only when the optional Analogue Extension Module (NAIO) is installed and activated by setting Parameter 98.06 AI/O EXT MODULE to UNIPOLAR PRGUNIP AO PROG, BIP AO PROG, UNIP AIO PROG or BIP AIO PROG. The parameters define the content and handling of the analogue output signals of the module.

The Range/Unit column in the table below shows the parameters. The text following the table explains the parameters in detail.

*Table 6-34 Group 96 parameters.*

Parameter	Range/Unit	Description
1 EXT AO1	Refer to the text below for the available selections.	Content of the extension module analogue output 1.
2 INVERT EXT AO1	NO; YES	Extension module analogue output signal 1 inversion.
3 MINIMUM EXT AO1	0 mA; 4 mA; 10 mA; 12 mA	Extension module analogue output signal 1 minimum.
4 FILTER EXT AO1	0.00 ... 10.00 s	Filter time constant for extension module AO1.
5 SCALE EXT AO1	10 ... 1000 %	Extension module analogue output signal 1 scaling factor.
6 EXT AO2	Refer to the text below for the available selections.	Extension module analogue output 2 content.
7 INVERT EXT AO2	NO; YES	Extension module analogue output signal 2 inversion.
8 MINIMUM EXT AO2	0 mA; 4 mA; 10 mA; 12 mA	Extension module analogue output signal 2 minimum.
9 FILTER EXT AO2	0.00 ... 10.00 s	Filter time constant for extension module AO2.
10 SCALE EXT AO2	10 ... 1000 %	Extension module analogue output signal 2 scaling factor.

**96.01 EXT AO1**

This parameter allows you to select which signal is connected to analogue output AO1 of the analogue extension module. The alternative settings are the same as for the standard analogue outputs. See Parameter 15.01 ANALOGUE OUTPUT1 (O).

**96.02 INVERT EXT AO1**

If you select YES, the Extension module analogue output AO1 signal is inverted.

96.03 MINIMUM EXT AO1

The minimum value of the Extension module analogue output signal can be set to either 0 mA, 4 mA, 10 mA or 12 mA. Actually, the setting 10 mA or 12 mA does not set the AO1 minimum but fixes 10/12 mA to actual signal value zero. See the figure below.

**Example:** Motor speed is read through the analogue output.

- Motor nominal speed is 1000 rpm (Parameter 99.08 MOTOR NOM SPEED).
- 96.02 INVERT EXT AO1 is NO
- 96.05 SCALE EXT AO1 is 100 %

The analogue output value as a function of speed is shown below.

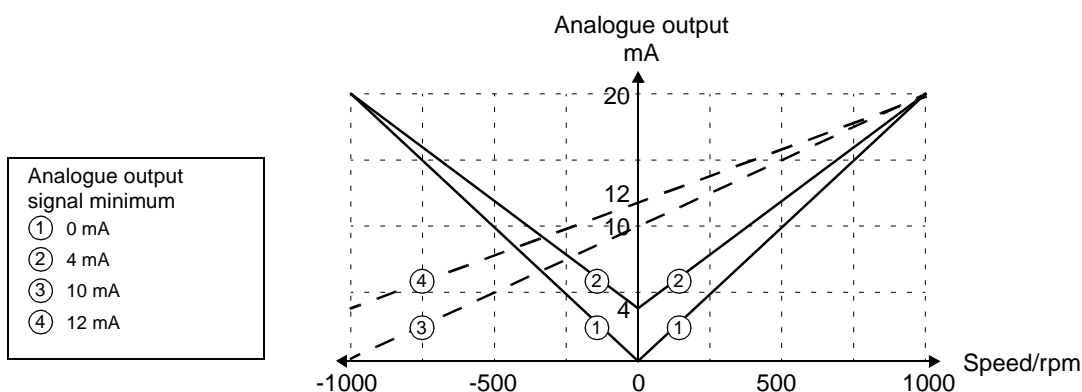

96.04 FILTER EXT AO1

Filter time constant for Extension module analogue output AO1. See Parameter 15.04 FILTER AO1.

96.05 SCALE EXT AO1

This parameter is the scaling factor for the Extension module analogue output AO1 signal. See Parameter 15.05 SCALE AO1.

96.06 EXT AO2

See Parameter 96.01 EXT AO1.

96.07 INVERT EXT AO2

See Parameter 96.02 INVERT EXT AO1.

96.08 MINIMUM EXT AO2

See Parameter 96.03 MINIMUM EXT AO1.

96.09 FILTER EXT AO2

See Parameter 96.04 FILTER EXT AO1.

96.10 SCALE EXT AO2

See Parameter 96.05 SCALE EXT AO1.



**Group 98 Option Modules**

The parameters of this group are set if an option module is installed or external serial communication is in use. For more information on option modules refer to the option module manuals.

These parameter values cannot be altered with the ACS 600 running.

These parameter settings will remain the same even though the application macro is changed.

*Table 6-35 Group 98 parameters.*

Parameter	Range	Description
98.01 ENCODER MODULE	NO; YES	Pulse encoder option module selection. See also <i>Parameter Group 50 Encoder Module</i> .
98.02 COMM. MODULE LINK	NO; FIELDBUS; ADVANT: STD MODBUS; CUSTOMISED	Option module selection. See also <i>Group 51 Communication Module</i> .
98.03 DI/O EXT MODULE 1	NO; YES	Option module selection.
98.04 DI/O EXT MODULE 2	NO; YES	Option module selection.
98.05 DI/O EXT MODULE 3	NO; YES	Option module selection.
98.06 AI/O EXT MODULE	NO; UNIP AIO PRG; BIP AIO PRG; UNIPOLAR; BIPOLAR; UNIP AO PRG; BIP AO PRG	Option module selection.
98.07 COMM PROFILE	ABB DRIVES; CSA2.8/3.0	Communication profile selection
98.08 NIOC-01 BOARD	NO; YES	Enable/disable the NIOC board supervision function
98.09 NDIO1 DI FUNC	DI7,8; REPL DI1,2	Selects the use of the NDIO module no. 1 input channels
98.10 NDIO2 DI FUNC	DI9,10; REPL DI1,2	Selects the use of the NDIO module no. 2 input channels
98.11 NDIO3 DI FUNC	DI11,12; REPL DI1,2	Selects the use of the NDIO module no. 3 input channels
98.12 AI/O MOTOR TEMP	NO; UNIPOLAR	NAIO module setting for motor temperature measuring

**98.01 ENCODER MODULE**

Set to YES if pulse encoder module (optional) is installed. Set the module node number to 16 (for directions see module manual). See also Parameter Group 50.

**98.02 COMM. MODULE LINK** This parameter selects the external serial communication interface. See *Appendix C – Fieldbus Control*.

**NO**

No external serial communication in use.

**FIELDBUS**

ACS 600 communicates with a communication module (e.g. fieldbus adapter) via CH0 Fieldbus Adapter link. See also *Parameter Group 51 Communication Module*.

**ADVANT**

ACS 600 communicates with an ABB Advant OCS system via CH0 Fieldbus Adapter link. See also *Parameter Group 70 DDCS Control*.

**STD MODBUS**

ACS 600 communicates with a Modbus controller via the Standard Modbus link. See also *Parameter Group 52 Standard Modbus*.

**CUSTOMISED**

ACS 600 can be controlled via two serial communication interfaces simultaneously. The control sources must be defined by the user with *Parameter 90.04 MAIN DS SOURCE* and *90.05 AUX DS SRCE*.

**98.03 DI/O EXT MODULE 1** Set to YES if external digital input/output module 1 (NDIO; optional) is installed. Set the module node number to 2 (for directions see module manual).

**NO**

Communication between ACS 600 and the NDIO module 1 inactive. This is the default value.

**YES**

Communication between ACS 600 and the NDIO module 1 active.

- *Parameter 98.09 NDIO1 DI FUNC* further defines the use of the digital inputs in the application program.
- *Parameters 14.10 NDIO MOD1 RO1* and *14.11 NDIO MOD1 RO2* select the drive states that are indicated through the relay outputs.

**98.04 DI/O EXT MODULE 2** Set to YES if a second NDIO module (digital input/output module 2) is installed. Set the module node number to 3 (for directions see module manual).

**NO**

Communication between ACS 600 and the NDIO module 2 inactive. This is the default value.

**YES**

Communication between ACS 600 and the NDIO module 2 active.

- *Parameter 98.10 NDIO2 DI FUNC* further defines the use of the digital inputs in the application program.
- *Parameters 14.12 NDIO MOD2 RO1* and *14.13 NDIO MOD2 RO2* select the drive states that are indicated through the relay outputs.

**98.05 DI/O EXT MODULE 3** Set to YES if a third NDIO module (digital input/output module 3) is installed. Set the module node number to 4 (for directions see module manual).

**NO**

No communication between drive and NDIO module 3. This is the default value.

**YES**

Communication between drive and NDIO module 3 active.

- Parameter 98.11 NDIO3 DI FUNC further defines the use of the digital inputs in the application program.
- Parameters 14.14 NDIO MOD3 RO1 and 14.15 NDIO MOD3 RO2 select the drive states that are indicated through the relay outputs.

**98.06 AI/O EXT MODULE** Parameter activates the communication to an optional analogue input/output extension module, NAIO.

---

**Note:** Before setting the ACS 600 parameters, ensure the NAIO module hardware settings (DIP switches) are OK:

- The NAIO module node number is set to 5.
- The input signal type selections matches the actual signals (mA/V).
- For type NAIO-03 module the operation mode selection matches the applied input signals (unipolar/bipolar).

For directions see *Installation and Start-up Guide for NTAC-0x/NDIO-0x/NAIO-0x Modules* (EN code: 3AFY 58919730).

For information on the NAIO module with the ACS 600 Standard Application Program, see also *Appendix D – Analogue Extension Module NAIO*.

---

**NO**

No communication between the drive and the NAIO module. This is the default value.

**UNIP AIO PROG**

Unipolar NAIO module inputs: Total number of I/Os in the application program is increased. The application program handles the analogue I/O's as follows:

- Input type: 0 to 20 mA (0 to 10 V)
- Total no. of inputs: 5
- Total no. of outputs: 4
- Input terminals:

Input name in the application program	Physical input terminal
AI1	AI1 on NIOC
AI2	AI2 on NIOC
AI3	AI3 on NIOC
AI1/JOYST	AI1 on NIOC
AI2/JOYST	AI2 on NIOC
AI5	AI1 on NAIO
AI6	AI2 on NAIO
AI5/JOYST	AI1 on NAIO
AI5/JOYST	AI2 on NAIO

- Output terminals:

Output value selector in the application program	Physical output terminal
15.01 ANALOGUE OUTPUT1 (O)	AO1 on NIOC
15.06 ANALOGUE OUTPUT2 (O)	AO2 on NIOC
96.01 EXT AO1	AO1 on NAIO
96.06 EXT AO2	AO2 on NAIO

**BIP AIO PROG**

Bipolar NAIO module inputs: Total number of I/Os in the application program is increased. The application program handles the analogue I/O's as follows:

- Input type: -20 to 20 mA (-10 to 10 V)
- Total no. of inputs: See selection UNIP AIO PROG
- Total no. of outputs: See selection UNIP AIO PROG
- Input terminals: See selection UNIP AIO PROG
- Output terminals: See selection UNIP AIO PROG

**UNIPOLAR**

Unipolar NAI0 module inputs: Total number of I/Os in the application program is not increased. The application program handles the analogue I/O's as follows:

- Input type: 0 to 20 mA (0 to 10 V)
- Total no. of inputs: 3
- Total no. of outputs: 2
- Input terminals:

Input name in the application program	Physical input terminal
AI1	AI1 on NIOC
AI2	AI1 on NAI0
AI3	AI2 on NAI0
AI1/JOYST	AI2 on NAI0
AI2/JOYST	AI1 on NAI0
AI5	AI1 on NAI0
AI6	AI2 on NAI0
AI5/JOYST	AI1 on NAI0
AI6/JOYST	AI2 on NAI0

- Output terminals:

Output value selector in the application program	Physical output terminal
15.01 ANALOGUE OUTPUT1 (O)	AO1 on NIOC and AO1 on NAI0
15.06 ANALOGUE OUTPUT2 (O)	AO2 on NIOC and AO2 on NAI0

**BIPOLAR**

Bipolar NAI0 module inputs: Total number of I/Os in the application program is not increased. The application program handles the analogue I/O's as follows:

- Input type: -20 to 20 mA (-10 to 10 V)
- Total no. of inputs: See selection UNIPOLAR
- Total no. of outputs: See selection UNIPOLAR
- Input terminals: See selection UNIPOLAR
- Output terminals: See selection UNIPOLAR

**UNIP AO PROG**

Unipolar NAIO-module inputs: Total number of outputs in the application program is increased. The application program handles the analogue I/O's as follows:

- Input type: 0 to 20 mA (0 to 10 V)
- Total no. of inputs: 3
- Total no. of outputs: 4
- Input terminals:

Input name in the application program	Physical input terminal
AI1	AI1 on NIOC
AI2	AI1 on NAIO
AI3	AI2 on NAIO
AI1/JOYST	AI2 on NAIO
AI2/JOYST	AI1 on NAIO
AI5	AI1 on NAIO
AI6	AI2 on NAIO
AI5/JOYST	AI1 on NAIO
AI6/JOYST	AI2 on NAIO

- Output terminals:

Output value selector in the application program	Physical output terminal
15.01 ANALOGUE OUTPUT1 (O)	AO1 on NIOC
15.06 ANALOGUE OUTPUT2 (O)	AO2 on NIOC
96.01 EXT AO1	AO1 on NAIO
96.06 EXT AO2	AO2 on NAIO

**BIP AO PROG**

Bipolar NAIO-module inputs: Total number of outputs in the application program is increased. The application program handles the analogue I/O's as follows:

- Input type: -20 to 20 mA (-10 to 10 V)
- Total no. of inputs: See selection UNIP AO PRG
- Total no. of outputs: See selection UNIP AO PRG
- Input terminals: See selection UNIP AO PRG
- Output terminals See selection UNIP AO PRG

**98.07 COMM PROFILE**

This parameter is visible only when a fieldbus communication is activated with Parameter 98.02 COMM. MODULE LINK.

This parameter defines the profile on which the communication with the fieldbus or another ACS 600 is based.

**ABB DRIVES**

The default profile in ACS 600 application program version 5.0 and later.

**CSA 2.8/3.0**

Communication profile used in ACS 600 application program versions 2.8x and 3.x.

**98.08 NIOC-01 BOARD** The parameter enables or disables the communication supervision of the Standard I/O Board (NIOC).

**NO**

The communication to the NIOC board is not supervised.

**YES**

The communication to the NIOC board is supervised. This is the default value. The application program checks the communication to the NIOC board cyclically. If the communication fails, the program generates a warning “IO COMM”.

**98.09 NDIO1 DI FUNC** The parameter selects the use of the inputs of the Digital I/O Extension Module (NDIO) no. 1. See Parameter 98.03 DI/O EXT MODULE 1.

**DI7,8**

The DI1 and DI2 of the NDIO module extend the number of input channels. The NDIO inputs are named DI7 and DI8 in the ACS 600 application program.

**REPL DI1,2**

The DI1 and DI2 of the NDIO module replace the standard input channels DI1 and DI2 on the NIOC board. The NDIO inputs are named DI1 and DI2 in the ACS 600 application program. This is the default value.

**98.10 NDIO2 DI FUNC** The parameter selects the use of the inputs of the Digital I/O Extension Module (NDIO) no. 2. See Parameter 98.04 DI/O EXT MODULE 2.

**DI9,10**

The DI1 and DI2 of the NDIO module extend the total number of digital inputs. The NDIO inputs are named DI9 and DI10 in the ACS 600 application program.

**REPL DI3,4**

The DI1 and DI2 of the NDIO module replace the standard input channels DI3 and DI4. The NDIO inputs are named DI3 and DI4 in the ACS 600 application program. This is the default value.

**98.11 NDIO3 DI FUNC** The parameter selects the use of the inputs of the Digital I/O Extension Module (NDIO) no. 3. See Parameter 98.05 DI/O EXT MODULE 3.

**DI11,12**

The DI1 and DI2 of the NDIO module extend the total number of digital inputs. The NDIO inputs are named DI11 and DI12 in the ACS 600 application program.

**REPL DI5,6**

The DI1 and DI2 of the NDIO module replace the standard input channels DI5 and DI6. The NDIO inputs are named DI5 and DI6 in the ACS 600 application program. This is the default value.

98.12 AI/O MOTOR TEMP

The parameter sets an optional Analogue I/O Extension Module (NAIO) an interface for motor temperature measurement. For more information on the temperature measurement function and connections see, *Parameter Group 35 Mot Temp Meas.*

---

**Note:** Before setting the ACS 600 parameters, ensure the NAIO module hardware settings (DIP switches) are appropriate for the motor temperature measurement:

- The NAIO module node number is 9.
- The input signal type selections are the following:
  - for one Pt 100 sensor measurement, set the range to 0 - 2 V.
  - for two to three Pt 100 sensors or one to three PTC sensors, set the range to 0 - 10 V.
- For type NAIO-03 module, the operation mode selection is unipolar.

For directions see *Installation and Start-up Guide for NTAC-0x/NDIO-0x/NAIO-0x Modules* (English code: 3AFY 58919730).

---

**NO**

The NAIO module is not used in the motor temperature measurement.

**UNIPOLAR**

The NAIO module is used in the motor temperature measurement. The use of the analogue inputs (AI) and outputs (AO) of the NAIO module is shown in the table below.

<b>Motor 1 temperature measurement</b>	
AO1	AO1 feeds a constant current to the motor 1 temperature sensor. The current value depends on the setting of Parameter 35.01 MOT1 TEMP AI1 SEL: - AO1 is 9.1 mA with selections 1xPT100; 2xPT100; 3xPT100 - AO1 is 1.6 mA with selection 1..3 PTC
AI1	AI1 measures voltage over the motor 1 temperature sensor.
<b>Motor 2 temperature measurement</b>	
AO2	AO2 feeds a constant current to the motor 2 temperature sensor. The current value depends on the setting of Parameter 35.04 MOT2 TEMP AI2 SEL: - AO2 is 9.1 mA. with selections 1xPT100; 2xPT100; 3xPT100, - AO2 is 1.6 mA. with selection 1..3 PTC
AI2	AI2 measures voltage over the motor 2 temperature sensor.



## Chapter 7 – Fault Tracing

---



**WARNING!** All electrical installation and maintenance work described in this chapter should only be undertaken by a qualified electrician. The *Safety Instructions* on the first pages of this manual and the appropriate hardware manual must be followed.

---

### **Fault Tracing**

The ACS 600 is equipped with advanced protection features that continuously guard the unit against damage and down time due to incorrect operating conditions and electrical and mechanical malfunctions.

This chapter explains the ACS 600 fault tracing procedure with the Control Panel.

All Warning and Fault messages are presented in tables below with information on the cause and remedy for each case. Most Warning and Fault conditions can be identified and cured with that information. If not, contact an ABB service representative.

---

**CAUTION!** Do not attempt any measurement, parts replacement or other service procedure not described in this manual. Such action will void guarantee, endanger correct operation, and increase downtime and expense.

---

The Warning message disappears when any of the Control Panel keys are pressed. The Warning will reappear in one minute if conditions remain unchanged. If the frequency converter is operated with the Control Panel detached, the red LED in the Control Panel mounting platform indicates Fault condition.

For setting of programmable warning and fault messages and functions, refer to *Chapter 6 – Parameters*.

### **Fault Resetting**

An active fault can be reset either by pressing the keypad **RESET** key, by digital input or fieldbus, or switching the supply voltage off for a while. When the fault has been removed, the motor can be started.

---



**WARNING!** If an external source for start command is selected and it is ON, the ACS 600 (with Standard Application Program) will start immediately after fault reset. (If the fault has not been removed, the ACS 600 will trip again.)

---

**Fault History** When a Fault is detected, it is stored in the Fault History. The last Faults and Warnings are stored with the time the Fault was detected.



**WARNING!** After a fault reset, the drive will start if the start signal is on. Before the reset, switch off the external start signal or ensure that it is safe to start.

The Fault History can be viewed by pressing or in the Actual Signal Display Mode. The Fault History can then be scrolled with and . To exit the Fault History press or . The Fault History can be cleared by pressing the **RESET** key.

**Fault and Warning Messages** The Tables below show the warning and fault messages.

Table 7-1 The Warning Messages generated by the drive firmware.

WARNING	CAUSE	WHAT TO DO
ACS 600 TEMP	The ACS 600 internal temperature is excessive. A warning is given if inverter module temperature exceeds 115 °C.	Check ambient conditions. Check air flow and fan operation. Check heatsink fins for dust pick-up. Check motor power against unit power.
AI < MIN FUNC (programmable Fault Function 30.01)	An analogue control signal is below minimum allowed value. This can be caused by incorrect signal level or a failure in the control wiring.	Check for proper analogue control signal levels. Check the control wiring. Check AI < MIN FUNC Fault Function parameters.
PANEL LOSS (programmable Fault Function 30.02)	A Control Panel selected as active control location for the ACS 600 has ceased communicating.	Check the Panel is connected to the right connector (see the appropriate hardware manual). Check Control Panel connector. Replace Control Panel in the mounting platform. Check PANEL LOSS Fault Function parameters.
MOTOR TEMP (programmable Fault Function 30.04 ... 30.10)	Motor temperature is too high (or appears to be too high). This can be caused by excessive load, insufficient motor power, inadequate cooling or incorrect start-up data.	Check motor ratings, load and cooling. Check start-up data. Check MOTOR TEMP Fault Function parameters.
THERMISTOR (programmable Fault Function 30.04 ... 30.05)	Motor thermal protection mode selected as THERMISTOR and the temperature is excessive.	Check motor ratings and load. Check start-up data. Check thermistor connections for digital input DI6 of NIOC board.
MOTOR STALL (programmable Fault Function 30.10)	Motor is operating in the stall region. This can be caused by excessive load or insufficient motor power.	Check motor load and the ACS 600 ratings. Check MOTOR STALL Fault Function parameters.

WARNING	CAUSE	WHAT TO DO
COMM MODULE (programmable Fault Function)	Cyclical communication between ACS 600 and fieldbus/ACS 600 Master is lost.	Check the status of fieldbus communication. See <i>Appendix C – Fieldbus Control</i> , or the appropriate fieldbus adapter manual. Check the parameter settings: - Group 51 (for CH0 fieldbus adapter), or - Group 52 (for Standard Modbus Link) Check cable connections. Check if the bus master is not communicating or configured.
UNDERLOAD (programmable Fault Function 30.13)	Motor load is too low. This can be caused by a release mechanism in the driven equipment.	Check for a problem in the driven equipment. Check UNDERLOAD Fault Function parameters.
ENCODER ERR	Communication fault between the pulse encoder and the NTAC module or between the NTAC module and the ACS 600.	Check the pulse encoder and its wiring, the NTAC module, Parameter Group 50 settings and the fibre optic connections on NAMC channel CH1.
ID N CHANGED	The ID number of the drive has been changed from 1 in Drive Selection Mode (the change is not shown on the display).	To change the ID number back to 1 go to Drive Selection Mode by pressing <b>DRIVE</b> . Press <b>ENTER</b> . Set the ID number to 1. Press <b>ENTER</b> .
MACRO CHANGE	Macro is restoring or user Macro is being saved.	Please wait.
ID MAGN REQ	Motor identification is required. This warning belongs to the normal start-up procedure. The drive expects the user to select how the motor identification is to be performed: By ID magnetisation or by ID Run.	To start the ID magnetisation: Press the Start key. To start the ID Run procedure: Select the Identification Run type (See Parameter 99.10 MOTOR ID RUN).
ID MAGN	Motor identification magnetisation is on. This warning belongs to the normal start-up procedure.	Wait until the drive indicates that motor identification is completed.
ID DONE	The ACS 600 has performed the motor identification magnetisation and is ready for operation. This warning belongs to the normal start-up procedure.	Continue drive operation.
ID RUN SEL	Motor Identification Run is selected, and the drive is ready to start the ID Run. This warning belongs to the ID Run procedure.	Press Start key to start the Identification Run.
MOTOR STARTS	Motor Identification Run starts. This warning belongs to the IR Run procedure.	Wait until the drive indicates that motor identification is completed.
ID RUN	Motor Identification Run is on.	Wait until the drive indicates that Identification Run is completed.
ID DONE	The ACS 600 has performed the Identification Run and is ready for operation. This warning belongs to the ID Run procedure.	Continue drive operation.
ENCODER A<>B	The pulse encoder phasing is wrong: Phase A is connected to the terminal of phase B and vice versa.	Interchange the connection of pulse encoder phases A and B.

WARNING	CAUSE	WHAT TO DO
MOTOR 1 TEMP	Measured motor temperature has exceeded the alarm limit set by Parameter 35.02 MOT 1 TEMP ALM L.	Check that the value of the alarm limit is OK. Check that the actual number of the sensors corresponds to the parameter set value. Let the motor cool down. Ensure proper motor cooling: Check the cooling fan, clean the cooling surfaces, etc.
MOTOR 2 TEMP	Measured motor temperature has exceeded the alarm limit set by Parameter 35.05 MOT 2 TEMP ALM L.	Check that the value of the alarm limit is OK. Check that the actual number of the sensors corresponds to the parameter set value. Let the motor cool down. Ensure proper motor cooling: Check the cooling fan, clean the cooling surfaces, etc.
T MEAS ALM	Motor temperature measurement is out of the acceptable range.	Check the connections of the motor temperature measurement circuit. See <i>Group 35 Mot Temp Meas</i> for the circuit diagram.
BRAKE ACKN	Unexpected state of the brake acknowledge signal.	See <i>Group 42 Brake Control</i> . Check the connection of the brake acknowledgement signal.
IO CONF	An input or output of an optional I/O extension module has been selected as a signal interface in the application program but the communication to the appropriate I/O extension module has not been set accordingly.	Check the fault function description (Parameter 30.22 IO CONF FUNC) and <i>Group 98 Option Modules</i> . Correct the settings where necessary.
SLEEP MODE	The sleep function has entered the sleeping mode.	See <i>Group 40 PID Control</i> .

Table 7-2 The Warning Messages generated by the Control Panel firmware.

WARNING	CAUSE	WHAT TO DO
WRITE ACCESS DENIED PARAMETER SETTING NOT POSSIBLE	Certain parameters do not allow changes while motor is running. If tried, no change is accepted, and a warning is displayed.  Parameter Lock is on.	Stop the motor then change the parameter value.  Open the parameter Lock (see Parameter 16.02 PARAMETER LOCK).
DOWNLOAD FAILED	Download function of the panel has failed. No data has been copied from the Panel to the ACS 600.	Make sure the Panel is in local mode. Retry (there might be interference on the link). Contact an ABB representative.
UPLOAD FAILED	Upload function of the panel has failed. No data has been copied from the ACS 600 to the Panel.	Retry (there might be interference on the link). Contact an ABB representative.
NOT UPLOADED DOWNLOADING NOT POSSIBLE	No upload function has been performed.	Perform the Upload function before downloading. See <i>Chapter 2 – Overview of ACS 600 Programming and the CDP 312 Control Panel</i> .
DRIVE INCOMPATIBLE DOWNLOADING NOT POSSIBLE	Program versions in the Panel and in the ACS 600 do not match. It is not possible to copy data from Panel to the ACS 600.	Check the program versions (see Parameter <i>Group 33 Information</i> ).
DRIVE IS RUNNING DOWNLOADING NOT POSSIBLE	Downloading is not possible while the motor is running.	Stop the motor. Perform the downloading.
NO FREE ID NUMBERS ID NUMBER SETTING NOT POSSIBLE	The Panel Link already includes 31 stations.	Disconnect another station from the link to free an ID number.
NO COMMUNICATION (X)	There is a cabling problem or a hardware malfunction on the Panel Link.	Check the Panel Link connections. Press the RESET key. The panel reset may take up to half a minute, please wait.
	(4) = Panel type is not compatible with the version of the drive application program. CDP 312 Panel does not communicate with Standard Application Program (ACS) version 3.x or earlier. The CDP 311 Panel does not communicate with Standard Application Program (ACS) version 5.x or later.	Check the Panel type and the version of the drive application program. The Panel type is printed on the cover of the Panel. The application program version is stored in Parameter 33.02 APPL SW VERSION.

Table 7-3 The Fault Messages generated by the drive firmware.

FAULT	CAUSE	WHAT TO DO
TEMP	The internal temperature is excessive. The trip level of inverter module temperature is 125 °C.	Check ambient conditions. Check air flow and fan operation. Check heatsink fins for dust pick-up. Check motor power against unit power.
OVERCURRENT <sup>*)</sup>	Output current is excessive. The software overcurrent trip limit is $3.5 \cdot I_{2hd}$ .	Check motor load. Check acceleration time. Check motor and motor cable (including phasing). Check there are no power factor correction capacitors or surge absorbers in the motor cable. Check encoder cable (including phasing).
SHORT CIRC <sup>*)</sup>	There is a short-circuit in the motor cable(s) or motor.  The output bridge of the converter unit is faulty.	Check the motor and motor cable. Check there are no power factor correction capacitors or surge absorbers in the motor cable.  Consult an ABB representative.
PPCC LINK <sup>*)</sup>	The fibre optic link to the NINT board is faulty.	Check the fibre optic cables connected to the power plates.
DC OVERVOLT	Intermediate circuit DC voltage is excessive. DC overvoltage trip limit is $1.3 \cdot U_{1max}$ , where $U_{1max}$ is the maximum value of the mains voltage range. For 400 V units, $U_{1max}$ is 415 V. For 500 V units, $U_{1max}$ is 500 V. The actual voltage in the intermediate circuit corresponding to the mains voltage trip level is 728 V d.c. for 400 V units and 877 V d.c. for 500 V units.	Check that the overvoltage controller is on (Parameter 20.05). Check mains for static or transient overvoltage. Check Braking Chopper and Resistor (if used). Check deceleration time. Use Coasting To Stop function (if applicable). Retrofit the frequency converter with a Braking Chopper and a Braking Resistor.
SUPPLY PHASE	Intermediate circuit DC voltage is oscillating. This can be caused by a missing mains phase, a blown fuse or a rectifier bridge internal fault. A trip occurs when the DC voltage ripple is 13 per cent of the DC voltage.	Check mains fuses. Check for mains supply imbalance.
DC UNDERVOLT	Intermediate circuit DC voltage is not sufficient. This can be caused by a missing mains phase, a blown fuse or a rectifier bridge internal fault.  DC undervoltage trip limit is $0.65 \cdot U_{1min}$ , where $U_{1min}$ is the minimum value of the mains voltage range. For 400 V and 500 V units, $U_{1min}$ is 380 V. The actual voltage in the intermediate circuit corresponding to the mains voltage trip level is 334 V d.c.	Check mains supply and fuses.

FAULT	CAUSE	WHAT TO DO
OVERFREQ	<p>Motor is turning faster than the highest allowed speed. This can be caused by an incorrectly set minimum/maximum speed, insufficient braking torque or changes in the load when using torque reference.</p> <p>The trip level is 40 Hz over the operating range absolute maximum speed limit (Direct Torque Control mode active) or frequency limit (Scalar Control active). The operating range limits are set by Parameters 20.01 and 20.02 (DTC mode active) or 20.07 and 20.08 (Scalar Control active).</p>	<p>Check minimum/maximum speed settings. Check adequacy of motor braking torque. Check applicability of torque control. Check the need for a Braking Chopper and Resistor(s).</p>
START INHIBIT	Optional start inhibit hardware logic is activated.	Check the start inhibit circuit (NGPS board).
EARTH FAULT*) (programmable Fault Function 30.17)	The load on the incoming mains system is out of balance. This can be caused by a fault in the motor, motor cable or an internal malfunction.	<p>Check motor. Check motor cable. Check there are no power factor correction capacitors or surge absorbers in the motor cable.</p>
AI < MIN FUNC (programmable Fault Function 30.01)	An analogue control signal is below minimum allowed value. This can be caused by incorrect signal level or a failure in the control wiring.	<p>Check for proper analogue control signal levels. Check the control wiring. Check AI &lt; MIN FUNC Fault Function parameters.</p>
PANEL LOSS (programmable Fault Function 30.02)	A Control Panel or Drives Window selected as active control location for the ACS 600 has ceased communicating.	<p>Check the Panel is connected to the right connector (see the appropriate hardware manual). Check Control Panel connector. Re-insert Control Panel in the mounting platform. Check PANEL LOSS Fault Function parameters. Check DrivesWindow connection.</p>
EXTERNAL FLT (programmable Fault Function 30.03)	There is a fault in one of the external devices. (This information is configured through one of the programmable digital inputs.)	<p>Check external devices for faults. Check Parameter 30.03 EXTERNAL FAULT.</p>
MOTOR TEMP (programmable Fault Function 30.04 ... 30.09)	Motor temperature is too high (or appears to be too high). This can be caused by excessive load, insufficient motor power, inadequate cooling or incorrect start-up data.	<p>Check motor ratings and load. Check start-up data. Check MOTOR TEMP Fault Function parameters.</p>
THERMISTOR (programmable Fault Function 30.04 ... 30.05)	Motor thermal protection mode selected as THERMISTOR and the temperature is excessive.	<p>Check motor ratings and load. Check start-up data. Check thermistor connections for digital input DI6. Check thermistor cabling.</p>
I/O COMM	<p>A communication error has occurred on the NAMC board, channel CH1.</p> <p>Electromagnetic interference.</p> <p>There is an internal fault on the NIOC board.</p>	<p>Check the connections of the fibre optic cables on NAMC channel CH1. Check all I/O modules (if present) connected to channel CH1. Check for proper earthing of the equipment. Check for highly emissive components nearby. Replace the NIOC board.</p>

FAULT	CAUSE	WHAT TO DO
AMBIENT TEMP	I/O Control board temperature is lower than -5...0 °C or exceeds +73...82 °C.	Check air flow and fan operation.
USER MACRO	There is no User Macro saved or the file is defective.	Create the User Macro again.
MOTOR STALL (programmable Fault Function 30.10 ... 30.12)	Motor is operating in the stall region. This can be caused by excessive load or insufficient motor power.	Check motor load and the ACS 600 ratings. Check MOTOR STALL Fault Function parameters.
NO MOT DATA	Motor data is not given or motor data does not match with inverter data.	Check the motor data given by Parameters 99.04... 99.09.
UNDERLOAD (programmable Fault Function 30.13 ... 30.15)	Motor load is too low. This can be caused by a release mechanism in the driven equipment.	Check for a problem in the driven equipment. Check UNDERLOAD Fault Function parameters.
ID RUN FAIL	The Motor ID Run is not completed successfully.	Check the maximum speed (Parameter 20.02). It should be at least 80 % of the nominal speed of the motor (Parameter 99.08).
MOTOR PHASE (programmable Fault Function 30.16 (ACC: 30.10))	One of the motor phases is lost. This can be caused by a fault in the motor, the motor cable, a thermal relay (if used) or an internal fault.	Check motor and motor cable. Check thermal relay (if used). Check MOTOR PHASE Fault Function parameters. Disable this protection.
COMM MODULE (programmable Fault Function)	Cyclical communication with ACS 600 and fieldbus/ACS 600 Master is lost.	Check the status of fieldbus communication. See <i>Appendix C – Fieldbus Control</i> , or the appropriate fieldbus adapter manual. Check the parameter settings: - Group 51 (for CH0 fieldbus adapter), or - Group 52 (for Standard Modbus Link) Check cable connections. Check if the bus master is not communicating or configured.
LINE CONV	Fault on the line side converter.	Shift the Panel from the motor side converter control board to the line side converter control board. See the line side converter manual for the fault description.
SC (INU 1)* SC (INU 2) SC (INU 3) SC (INU 4)	Short circuit in inverter unit consisting of several parallel inverter modules. Number refers to the faulty inverter module number.  NINT board fibre optic connection fault in inverter unit consisting of several parallel inverter modules. Number refers to the inverter module number.	Check the motor and motor cable. Check the power semiconductors (IGBT power plates) of the inverter module. (INU 1 stands for inverter module 1 etc.).  Check the connection from the inverter module Main Circuit Interface Board, NINT to the PPCC Branching Unit, NPBU. (inverter module 1 is connected to NPBU CH1 etc.)
CURR MEAS	Current transformer failure in output current measurement circuit.	Check the current transformers connected to Main Circuit Interface Board, NINT.



FAULT	CAUSE	WHAT TO DO
ENCODER ERR	Communication fault between the pulse encoder and the NTAC module or between the NTAC module and the ACS 600.	Check the pulse encoder and its wiring, the NTAC module, Parameter Group 50 settings and the fibre optic connections on NAMC channel CH1.
ENCODER A<>B	The pulse encoder phasing is wrong: Phase A is connected to the terminal of phase B and vice versa.	Interchange the connection of pulse encoder phases A and B.
MOTOR 1 TEMP	Measured motor temperature has exceeded the fault limit set by Parameter 35.03 MOT 1 TEMP FLT L.	Check that the value of the fault limit is ok. Let the motor cool down. Ensure proper motor cooling: Check the cooling fan, clean the cooling surfaces, etc.
MOTOR 2 TEMP	Measured motor temperature has exceeded the fault limit set by Parameter 35.06 MOT 2 TEMP FLT L.	Check that the value of the fault limit is ok. Let the motor cool down. Ensure proper motor cooling: Check the cooling fan, clean the cooling surfaces, etc.
THERMAL MODE	The motor thermal protection mode is set to DTC for a high-power motor.	See Parameter 30.05 MOT THERM P MODE.
BRAKE ACKN	Unexpected state of the brake acknowledge signal.	See <i>Group 42 Brake Control</i> . Check the connection of the brake acknowledgement signal.
IO CONF	An input or output of an optional I/O extension module has been selected as a signal interface in the application program but the communication to the appropriate I/O extension module has not been set accordingly.	Check the fault function description (Parameter 30.22 IO CONF FUNC) and <i>Group 98 Option Modules</i> . Correct the settings where necessary.

\*) More detailed information on the high power units with parallel inverters is given in fault word 3.12 INT FAULT INFO (see *Appendix C – Fieldbus Control*).



# Appendix A – Complete Parameter Settings

The tables in this Appendix list all the actual signals and parameters with their alternative settings of the ACS 600.

The numbers in brackets ( ) in the Range/Unit and Alternative Settings columns show the numerical equivalents for fieldbus use.

**Note for Interbus-S (NIBA-01 module) Users:** The Parameter Index equals ((Drive Parameter No.) • 100 + 12288) converted to hexadecimal. Example: the index for drive parameter 13.09 is 1309 + 12288 = 13597 = 351Dh.

Table A-1 Group 1 Actual Signals.

No.	Signal	Short name	Range/Unit ( ) Fieldbus Equivalent	PROFIBUS Par. No. (Add 4000 in FMS Mode)	Modbus/ Modbus Plus Par. No.	Scaling for Fieldbus
1.01	PROCESS VARIABLE	PROC VAR	NO; rpm; %; m/s; A; V; Hz; s; h; kh; C; lft; mA; mV; kW; W; kWh; F; hp; MWh; m3h; l/s; bar; kPa; GPM; PSI; CFM; ft; MGD; iHg; FPM	1	40101	1 = 1
1.02	SPEED	SPEED	rpm	2	40102	-20000 = -100 % 20000 = 100 % <b>of motor absolute max. speed</b>
1.03	FREQUENCY	FREQ	Hz	3	40103	-100 = -1 Hz 100 = 1 Hz
1.04	CURRENT	CURRENT	A	4	40104	10 = 1 A
1.05	TORQUE	TORQUE	%	5	40105	-10000 = -100 % 10000 = 100 % <b>of motor nominal torque</b>
1.06	POWER	POWER	%	6	40106	0 = 0 % 1000 = 100 % <b>of motor nominal power</b>
1.07	DC BUS VOLTAGE V	DC BUS V	V	7	40107	1 = 1 V
1.08	MAINS VOLTAGE	MAINS V	V	8	40108	1 = 1 V
1.09	OUTPUT VOLTAGE	OUT VOLT	V	9	40109	1 = 1 V
1.10	ACS 600 TEMP	ACS TEMP	C	10	40110	1 = 1 °C
1.11	EXTERNAL REF 1	EXT REF1	rpm	11	40111	1 = 1 rpm
1.12	EXTERNAL REF 2	EXT REF2	%	12	40112	0 = 0 % 10000 = 100 % <b>of motor max. speed / nominal torque / max. process reference (depending on the ACS 600 macro selected)</b>
1.13	CTRL LOCATION	CTRL LOC	(1,2) LOCAL; (3) EXT1; (4) EXT2	13	40113	(see Range/Unit)
1.14	OP HOUR COUNTER	OP HOURS	h	14	40114	1 = 1 h
1.15	KILOWATT HOURS	KW HOURS	kWh	15	40115	1 = 100 kWh
1.16	APPL BLOCK OUTPUT	APPL OUT	%	16	40116	0 = 0 % 10000 = 100 %
1.17	DI6-1 STATUS	DI6-1		17	40117	
1.18	AI1 [V]	AI1 [V]	V	18	40118	1 = 0.001 V
1.19	AI2 [mA]	AI2 [mA]	mA	19	40119	1 = 0.001 mA

Appendix A – Complete Parameter Settings

No.	Signal	Short name	Range/Unit ( ) Fieldbus Equivalent	PROFIBUS Par. No. (Add 4000 in FMS Mode)	Modbus/ Modbus Plus Par. No.	Scaling for Fieldbus
1.20	AI3 [mA]	AI3 [mA]	mA	20	40120	1 = 0.001 mA
1.21	RO3-1 STATUS	RO3-1		21	40121	
1.22	AO1 [mA]	AO1 [mA]	mA	22	40122	1 = 0.001 mA
1.23	AO2 [mA]	AO2 [mA]	mA	23	40123	1 = 0.001 mA
1.24	ACTUAL VALUE 1	ACT VAL1	%	24	40124	0 = 0 % 10000 = 100 %
1.25	ACTUAL VALUE 2	ACT VAL2	%	25	40125	0 = 0 % 10000 = 100 %
1.26	CONTROL DEVIATION	CONT DEV	%	26	40126	-10000 = -100 % 10000 = 100 %
1.27	APPLICATION MACRO	MACRO	(1) FACTORY; (2) HAND/AUTO; (3) PID.CTRL; (4) T-CTRL; (5) SEQ CTRL; (6) USER 1 LOAD; (7) USER 2 LOAD	27	40127	(see Range/Unit)
1.28	EXT AO1 [mA]	EXT AO1	mA	28	40128	1 = 0.001 mA
1.29	EXT AO2 [mA]	EXT AO2	mA	29	40129	1 = 0.001 mA
1.30	PP 1 TEMP	PP 1 TEM	°C	30	40130	1 = 1 °C
1.31	PP 2 TEMP	PP 2 TEM	°C	31	40131	1 = 1 °C
1.32	PP 3 TEMP	PP 3 TEM	°C	32	40132	1 = 1 °C
1.33	PP 4 TEMP	PP 4 TEM	°C	33	40133	1 = 1 °C
1.34	ACTUAL VALUE	ACT V	%	34	40134	0 = 0 % 10000 = 100 %
1.35	MOTOR 1 TEMP	M 1 TEMP	°C	35	40135	1 = 1 °C
1.36	MOTOR 2 TEMP	M 2 TEMP	°C	36	40136	1 = 1 °C
1.37	MOTOR TEMP EST	MOTOR TE	°C	37	40137	1 = 1 °C
1.38	AI5 [mA]	AI5 [mA]	mA	38	40138	1 = 0.001 mA
1.39	AI6 [mA]	AI6 [mA]	mA	39	40139	1 = 0.001 mA
1.40	DI7-12 STATUS	DI7..12		40	40140	
1.41	EXT RO STATUS	EXT RO		41	40141	
1.42	PROCESS SPEED REL	P SPEED	%	42	40142	1 = 1
1.43	MOTOR RUN TIME	MOTOR RUN TIME	h	43	40143	1 = 10 h

Table A-2 Group 2 Actual Signals for speed and torque reference monitoring.

No.	Signal	Short name	Range/Unit ( ) Fieldbus Equivalent	PROFIBUS Par. No. (Add 4000 in FMS Mode)	Modbus/ Modbus Plus Par. No.	Scaling for Fieldbus
2.01	SPEED REF 2	S REF 2	rpm	51	40201	0 = 0 % 20000 = 100 %
2.02	SPEED REF 3	S REF 3	rpm	52	40202	<b>of motor absolute max. speed</b>
2.09	TORQ REF 2	T REF 2	%	59	40209	0 = 0 % 10000 = 100 %
2.10	TORQ REF 3	T REF 3	%	60	40210	<b>of motor nominal torque</b>
2.13	TORQ USED REF	T USED R	%	63	40213	
2.17	SPEED ESTIMATED	SPEED ES	rpm	67	40217	0 = 0 % 20000 = 100 % <b>of motor absolute max. speed</b>
2.18	SPEED MEASURED	SPEED ME	rpm	68	40218	0 = 0 % 20000 = 100 % <b>of motor absolute max. speed</b>

Table A-3 Group 3 Actual Signals for fieldbus communication (each signal is a 16-bit data word).

No.	Signal	Short name	Range/Unit ( ) Fieldbus Equivalent	PROFIBUS Par. No. (Add 4000 in FMS Mode)	Modbus/ Modbus Plus Par. No.	Scaling for Fieldbus
3.01	MAIN CTRL WORD	MAIN CW	0 ... 65535 (Decimal)	76	40301	<p>The contents of these data words are detailed in <i>Appendix C – Fieldbus Control</i>.</p> <p>For the contents of Actual Signal 3.11, see the <i>Master/Follower Application Guide</i> (3AFY 58962180 [English])</p>
3.02	MAIN STATUS WORD	MAIN SW	0 ... 65535 (Decimal)	77	40302	
3.03	AUX STATUS WORD	AUX SW	0 ... 65535 (Decimal)	78	40303	
3.04	LIMIT WORD 1	LIMIT W1	0 ... 65535 (Decimal)	79	40304	
3.05	FAULT WORD 1	FAULT W1	0 ... 65535 (Decimal)	80	40305	
3.06	FAULT WORD 2	FAULT W2	0 ... 65535 (Decimal)	81	40306	
3.07	SYSTEM FAULT	SYS FLT	0 ... 65535 (Decimal)	82	40307	
3.08	ALARM WORD 1	ALARM W 1	0 ... 65535 (Decimal)	83	40308	
3.09	ALARM WORD 2	ALARM W 2	0 ... 65535 (Decimal)	84	40309	
3.11	FOLLOWER MCW	FOLL MCW	0 ... 65535 (Decimal)	86	40311	
3.12	INT FAULT INFO	INT FAUL	0 ... 65535 (Decimal)	87	40312	
3.13	AUX STATUS WORD 3	AUX SW 3	0 ... 65535 (Decimal)	88	40313	
3.14	AUX STATUS WORD 4	AUX SW 4	0 ... 65535 (Decimal)	89	40314	
3.15	FAULT WORD 3	FAULT W3	0 ... 65535 (Decimal)	90	40315	
3.16	ALARM WORD 3	ALARM W3	0 ... 65535 (Decimal)	91	40316	

Appendix A – Complete Parameter Settings

Table A-4 Parameter Settings.

Parameter	Alternative Settings ( ) Fieldbus Equivalent	PROFIBUS Par. No. (Add 4000 in FMS Mode)	Modbus/ Modbus Plus Par. No.	Scaling for Fieldbus
<b>99 START-UP DATA</b>				
99.01 LANGUAGE	(0) ENGLISH; (1) ENGLISH(AM); (2) DEUTSCH; (3) ITALIANO; (4) ESPANOL; (5) PORTUGUES; (6) NEDERLANDS; (7) FRANCAIS; (8) DANSK; (9) SUOMI; (10) SVENSKA	1926	49901	(see Alternative Settings)
99.02 APPLICATION MACRO	(1) FACTORY; (2) HAND/AUTO; (3) PID CTRL; (4) T CTRL; (5) SEQ CTRL; (6) USER 1 LOAD; (7) USER 1 SAVE; (8) USER 2 LOAD; (9) USER 2 SAVE	1927	49902	(see Alternative Settings)
99.03 APPLIC RESTORE	(0) NO; (1) YES	1928	49903	(see Alternative Settings)
99.04 MOTOR CTRL MODE	(0) DTC; (1) SCALAR	1929	49904	(see Alternative Settings)
99.05 MOTOR NOM VOLTAGE	$1/2 \cdot U_n$ of ACS 600 ... $2 \cdot U_n$ of ACS 600 (printed on the motor nameplate)	1930	49905	1 = 1 V
99.06 MOTOR NOM CURRENT	$1/6 \cdot I_{2nd}$ of ACS 600 ... $2 \cdot I_{2nd}$ of ACS 600 (printed on the motor nameplate)	1931	49906	1 = 0.1 A
99.07 MOTOR NOM FREQ	8 Hz ... 300 Hz (printed on the motor nameplate)	1932	49907	1 = 0.01 Hz
99.08 MOTOR NOM SPEED	1 rpm ... 18000 rpm (printed on the motor nameplate)	1933	49908	1 = 1 rpm
99.09 MOTOR NOM POWER	0 kW ... 9000 kW (printed on the motor nameplate)	1934	49909	1 = 0.1 kW
99.10 MOTOR ID RUN	(1) NO; (2) STANDARD; (3) REDUCED	1935	49910	(see Alternative Settings)
<b>10 START/STOP/DIR</b>				
10.01 EXT1 STRT/STP/DIR	(1) NOT SEL; (2) DI1; (3) DI1,2; (4) DI1P,2P; (5) DI1P,2P,3; (6) DI1P,2P,3P; (7) DI6; (8) DI6,5; (9) KEYPAD; (10) COMM. MODULE; (11) DI7; (12) DI7,8; (13) DI7P,8P; (14) DI7P,8P,9; (15) DI7P,8P,9P	101	41001	(see Alternative Settings)
10.02 EXT2 STRT/STP/DIR	(1) NOT SEL; (2) DI1; (3) DI1,2; (4) DI1P,2P; (5) DI1P,2P,3; (6) DI1P,2P,3P; (7) DI6; (8) DI6,5; (9) KEYPAD; (10) COMM. MODULE; (11) DI7; (12) DI7,8; (13) DI7P,8P; (14) DI7P,8P,9; (15) DI7P,8P,9P	102	41002	(see Alternative Settings)
10.03 DIRECTION	(1) FORWARD; (2) REVERSE; (3) REQUEST	103	41003	(see Alternative Settings)
<b>11 REFERENCE SELECT</b>				
11.01 KEYPAD REF SEL	(1) REF1(rpm); (2) REF2(%)	126	41101	(see Alternative Settings)
11.02 EXT1/EXT2 SELECT	(1) DI1; (2) DI2; (3) DI3; (4) DI4; (5) DI5; (6) DI6; (7) EXT1; (8) EXT2; (9) COMM. MODULE; (10) DI7; (11) DI8; (12) DI9; (13) DI10; (14) DI11; (15) DI12;	127	41102	(see Alternative Settings)
11.03 EXT REF1 SELECT	(1) KEYPAD; (2) AI1; (3) AI2; (4) AI3; (5) AI1/JOYST; (6) AI2/JOYST; (7) AI1+AI3; (8) AI2+AI3; (9) AI1-AI3; (10) AI2-AI3; (11) AI1*AI3; (12) AI2*AI3; (13) MIN(AI1,AI3); (14) MIN(AI2,AI3); (15) MAX(AI1,AI3); (16) MAX(AI2,AI3); (17) DI3U,4D(R); (18) DI3U,4D; (19) DI5U,6D; (20) COMM. REF; (21) COMMREF+AI1; (22) COMMREF*AI1; (23) FAST COMM; (24) COMMREF+AI5; (25) COMMREF*AI5; (26) AI5; (27) AI6; (28) AI5/JOYST; (29) AI6/JOYST; (30) AI5+AI6; (31) AI5-AI6; (32) AI5*AI6; (33) MIN(AI5,6); (34) MAX(AI5,6); (35) DI11U,12D(R); (36) DI11U,12D	128	41103	(see Alternative Settings)
11.04 EXT REF1 MINIMUM	0 ... 18000 rpm	129	41104	1 = 1 rpm
11.05 EXT REF1 MAXIMUM	0 ... 18000 rpm	130	41105	1 = 1 rpm
11.06 EXT REF2 SELECT	(1) KEYPAD; (2) AI1; (3) AI2; (4) AI3; (5) AI1/JOYST; (6) AI2/JOYST; (7) AI1+AI3; (8) AI2+AI3; (9) AI1-AI3; (10) AI2-AI3; (11) AI1*AI3; (12) AI2*AI3; (13) MIN(AI1,AI3); (14) MIN(AI2,AI3); (15) MAX(AI1,AI3); (16) MAX(AI2,AI3); (17) DI3U,4D(R); (18) DI3U,4D; (19) DI5U,6D; (20) COMM. REF; (21) COMMREF+AI1; (22) COMMREF*AI1; (23) FAST COMM; (24) COMMREF+AI5; (25) COMMREF*AI5; (26) AI5; (27) AI6; (28) AI5/JOYST; (29) AI6/JOYST; (30) AI5+AI6; (31) AI5-AI6; (32) AI5*AI6; (33) MIN(AI5,6); (34) MAX(AI5,6); (35) DI11U,12D(R); (36) DI11U,12D	131	41106	(see Alternative Settings)

Parameter	Alternative Settings ( ) Fieldbus Equivalent	PROFIBUS Par. No. (Add 4000 in FMS Mode)	Modbus/ Modbus Plus Par. No.	Scaling for Fieldbus
11.07 EXT REF2 MINIMUM	0 % ... 100 %	132	41107	0 = 0 % 10000 = 100 %
11.08 EXT REF2 MAXIMUM	0 % ... 500 %	133	41108	0 = 0 % 5000 = 500 %
<b>12 CONSTANT SPEEDS</b>				
12.01 CONST SPEED SEL	<b>(1)</b> NOT SEL; <b>(2)</b> DI1 (SPEED1); <b>(3)</b> DI2 (SPEED2); <b>(4)</b> DI3 (SPEED3); <b>(5)</b> DI4 (SPEED4); <b>(6)</b> DI5 (SPEED5); <b>(7)</b> DI6 (SPEED6); <b>(8)</b> DI1,2; <b>(9)</b> DI3,4; <b>(10)</b> DI5,6; <b>(11)</b> DI1,2,3; <b>(12)</b> DI3,4,5; <b>(13)</b> DI4,5,6; <b>(14)</b> DI3,4,5,6; <b>(15)</b> DI7(SPEED1); <b>(16)</b> DI8 (SPEED2); <b>(17)</b> DI9(SPEED3); <b>(18)</b> DI10 (SPEED4); <b>(19)</b> DI11(SPEED5); <b>(20)</b> DI12 (SPEED6); <b>(21)</b> DI7,8; <b>(22)</b> DI9,10; <b>(23)</b> DI11,12	151	41201	(see <b>Alternative Settings</b> )
12.02 CONST SPEED 1	0 ... 18000 rpm	152	41202	1 = 1 rpm
12.03 CONST SPEED 2	0 ... 18000 rpm	153	41203	
12.04 CONST SPEED 3	0 ... 18000 rpm	154	41204	
12.05 CONST SPEED 4	0 ... 18000 rpm	155	41205	
12.06 CONST SPEED 5	0 ... 18000 rpm	156	41206	
12.07 CONST SPEED 6	0 ... 18000 rpm	157	41207	
12.08 CONST SPEED 7	0 ... 18000 rpm	158	41208	
12.09 CONST SPEED 8	0 ... 18000 rpm	159	41209	
12.10 CONST SPEED 9	0 ... 18000 rpm	160	41210	
12.11 CONST SPEED 10	0 ... 18000 rpm	161	41211	
12.12 CONST SPEED 11	0 ... 18000 rpm	162	41212	
12.13 CONST SPEED 12	0 ... 18000 rpm	163	41213	
12.14 CONST SPEED 13	0 ... 18000 rpm	164	41214	
12.15 CONST SPEED 14	0 ... 18000 rpm	165	41215	
12.16 CONST SPEED 15	-18000 ... 18000 rpm	166	41216	
<b>13 ANALOGUE INPUTS</b>				
13.01 MINIMUM AI1	<b>(1)</b> 0 V; <b>(2)</b> 2 V; <b>(3)</b> TUNED VALUE; <b>(4)</b> TUNE	176	41301	(see <b>Alternative Settings</b> )
13.02 MAXIMUM AI1	<b>(1)</b> 10 V; <b>(2)</b> TUNED VALUE; <b>(3)</b> TUNE	177	41302	(see <b>Alternative Settings</b> )
13.03 SCALE AI1	0 ... 100 %	178	41303	0 = 0 % 10000 = 100 %
13.04 FILTER AI1	0.00 s ... 10.00 s	179	41304	0 = 0 s 1000 = 10 s
13.05 INVERT AI1	<b>(0)</b> NO; <b>(65535)</b> YES	180	41305	(see <b>Alternative Settings</b> )
13.06 MINIMUM AI2	<b>(1)</b> 0 mA; <b>(2)</b> 4 mA; <b>(3)</b> TUNED VALUE; <b>(4)</b> TUNE	181	41306	(see <b>Alternative Settings</b> )
13.07 MAXIMUM AI2	<b>(1)</b> 20 mA; <b>(2)</b> TUNED VALUE; <b>(3)</b> TUNE	182	41307	(see <b>Alternative Settings</b> )
13.08 SCALE AI2	0 ... 100 %	183	41308	0 = 0 % 10000 = 100 %
13.09 FILTER AI2	0.00 s ... 10.00 s	184	41309	0 = 0 s 1000 = 10 s
13.10 INVERT AI2	<b>(0)</b> NO; <b>(65535)</b> YES	185	41310	(see <b>Alternative Settings</b> )
13.11 MINIMUM AI3	<b>(1)</b> 0 mA; <b>(2)</b> 4 mA; <b>(3)</b> TUNED VALUE; <b>(4)</b> TUNE	186	41311	(see <b>Alternative Settings</b> )
13.12 MAXIMUM AI3	<b>(1)</b> 20 mA; <b>(2)</b> TUNED VALUE; <b>(3)</b> TUNE	187	41312	(see <b>Alternative Settings</b> )
13.13 SCALE AI3	0 ... 100 %	188	41313	0 = 0 % 10000 = 100 %
13.14 FILTER AI3	0.00 s ... 10.00 s	189	41314	0 = 0 s 1000 = 10 s
13.15 INVERT AI3	<b>(0)</b> NO; <b>(65535)</b> YES	190	41315	(see <b>Alternative Settings</b> )
13.16 MINIMUM AI5	<b>(1)</b> 0 mA; <b>(2)</b> 4 mA; <b>(3)</b> TUNED VALUE; <b>(4)</b> TUNE	191	41316	(see <b>Alternative Settings</b> )

Appendix A – Complete Parameter Settings

Parameter	Alternative Settings ( ) Fieldbus Equivalent	PROFIBUS Par. No. (Add 4000 in FMS Mode)	Modbus/ Modbus Plus Par. No.	Scaling for Fieldbus
13.17 MAXIMUM AI5	(1) 20 mA; (2) TUNED VALUE; (3) TUNE	192	41317	(see Alternative Settings)
13.18 SCALE AI5	0 ... 100 %	193	41318	0 = 0 % 10000 = 100 %
13.19 FILTER AI5	0.00 s ... 10.00 s	194	41319	0 = 0 s 1000 = 10 s
13.20 INVERT AI5	(0) NO; (65535) YES	195	41320	(see Alternative Settings)
13.21 MINIMUM AI6	(1) 0 mA; (2) 4 mA; (3) TUNED VALUE; (4) TUNE	196	41321	(see Alternative Settings)
13.22 MAXIMUM AI6	(1) 20 mA; (2) TUNED VALUE; (3) TUNE	197	41322	(see Alternative Settings)
13.23 SCALE AI6	0 ... 100 %	198	41323	0 = 0 % 10000 = 100 %
13.24 FILTER AI6	0.00 s ... 10.00 s	199	41324	0 = 0 s 1000 = 10 s
13.25 INVERT AI6	(0) NO; (65535) YES	200	41325	(see Alternative Settings)
<b>14 RELAY OUTPUTS</b>				
14.01 RELAY RO1 OUTPUT	Relay outputs 1, 2 & 3: (1) NOT USED; (2) READY; (3) RUNNING; (4) FAULT; (5) FAULT(-1); (6) FAULT(RST); (7) STALL WARN; (8) STALL FLT; (9) MOT TEMP WRN; (10) MOT TEMP FLT; (11) ACS TEMP WRN; (12) ACS TEMP FLT; (13) FAULT/WARN; (14) WARNING; (15) REVERSED; (16) EXT CTRL; (17) REF 2 SEL; (18) CONST SPEED; (19) DC OVERVOLT; (20) DC UNDERVOL; (21) SPEED 1 LIM; (22) SPEED 2 LIM; (23) CURRENT LIM; (24) REF 1 LIM; (25) REF 2 LIM; (26) TORQUE 1 LIM; (27) TORQUE 2 LIM; (28) STARTED; (29) LOSS OF REF; (30) AT SPEED; (33) COMM MODULE; (34) POINTERx; (35) BRAKE CTRL Relay output 1 & 2: (31) ACT 1 LIM; (32) ACT 2 LIM Relay output 3: (31) MAGN READY; (32) USER 2 SEL	201	41401	(see Alternative Settings)
14.02 RELAY RO2 OUTPUT		202	41402	
14.03 RELAY RO3 OUTPUT		203	41403	
14.04 RO1 TON DELAY	0.0 to 3600.0 s	204	41404	10 = 1 s
14.05 RO1 TOFF DELAY	0.0 to 3600.0 s	205	41405	10 = 1 s
14.06 RO2 TON DELAY	0.0 to 3600.0 s	206	41406	10 = 1 s
14.07 RO2 TOFF DELAY	0.0 to 3600.0 s	207	41407	10 = 1 s
14.08 RO3 TON DELAY	0.0 to 3600.0 s	208	41408	10 = 1 s
14.09 RO3 TOFF DELAY	0.0 to 3600.0 s	209	41409	10 = 1 s
14.10 NDIO MOD1 RO1	(1) READY; (2) RUNNING; (3) FAULT; (4) WARNING; (5) REF 2 SEL; (6) AT SPEED; (7) POINTER1	210	41410	(see Alternative Settings)
14.11 NDIO MOD1 RO2	(1) READY; (2) RUNNING; (3) FAULT; (4) WARNING; (5) REF 2 SEL; (6) AT SPEED; (7) POINTER2	211	41411	(see Alternative Settings)
14.12 NDIO MOD2 RO1	(1) READY; (2) RUNNING; (3) FAULT; (4) WARNING; (5) REF 2 SEL; (6) AT SPEED; (7) POINTER3	212	41412	(see Alternative Settings)
14.13 NDIO MOD2 RO2	(1) READY; (2) RUNNING; (3) FAULT; (4) WARNING; (5) REF 2 SEL; (6) AT SPEED; (7) POINTER4	213	41413	(see Alternative Settings)
14.14 NDIO MOD3 RO1	(1) READY; (2) RUNNING; (3) FAULT; (4) WARNING; (5) REF 2 SEL; (6) AT SPEED; (7) POINTER5	214	41414	(see Alternative Settings)
14.15 NDIO MOD3 RO2	(1) READY; (2) RUNNING; (3) FAULT; (4) WARNING; (5) REF 2 SEL; (6) AT SPEED; (7) POINTER6	215	41415	(see Alternative Settings)
<b>15 ANALOGUE OUTPUTS</b>				
15.01 ANALOGUE OUTPUT1	(1) NOT USED; (2) P SPEED; (3) SPEED; (4) FREQUENCY; (5) CURRENT; (6) TORQUE; (7) POWER; (8) DC BUS VOLT; (9) OUTPUT VOLT; (10) APPL OUTPUT; (11) REFERENCE; (12) CONTROL DEV; (13) ACTUAL 1; (14) ACTUAL 2; (15) COMM. MODULE; (16) M1 TEMP MEAS	226	41501	(see Alternative Settings)
15.02 INVERT AO1	(0) NO; (65535) YES	227	41502	(see Alternative Settings)
15.03 MINIMUM AO1	(1) 0 mA; (2) 4 mA	228	41503	(see Alternative Settings)



Parameter	Alternative Settings ( ) Fieldbus Equivalent	PROFIBUS Par. No. (Add 4000 in FMS Mode)	Modbus/ Modbus Plus Par. No.	Scaling for Fieldbus
15.04 FILTER AO1	0.00 s ... 10.00 s	229	41504	0 = 0 s 1000 = 10 s
15.05 SCALE AO1	10 % ... 1000 %	230	41505	100 = 10 % 10000 = 1000 %
15.06 ANALOGUE OUTPUT2	(1) NOT USED; (2) P SPEED; (3) SPEED; (4) FREQUENCY; (5) CURRENT; (6) TORQUE; (7) POWER; (8) DC BUS VOLT; (9) OUTPUT VOLT; (10) APPL OUTPUT; (11) REFERENCE; (12) CONTROL DEV; (13) ACTUAL 1; (14) ACTUAL 2; (15) COMM. MODULE	231	41506	(see Alternative Settings)
15.07 INVERT AO2	(0) NO; (65535) YES	232	41507	(see Alternative Settings)
15.08 MINIMUM AO2	(1) 0 mA; (2) 4 mA	233	41508	(see Alternative Settings)
15.09 FILTER AO2	0.00 s ... 10.00 s	234	41509	0 = 0 s 1000 = 10 s
15.10 SCALE AO2	10 % ... 1000 %	235	41510	100 = 10 % 10000 = 1000 %
<b>16 SYSTEM CTR INPUTS</b>				
16.01 RUN ENABLE	(1) YES; (2) DI1; (3) DI2; (4) DI3; (5) DI4; (6) DI5; (7) DI6; (8) COMM. MODULE; (9) DI7; (10) DI8; (11) DI9; (12) DI10; (13) DI11; (14) DI12	251	41601	(see Alternative Settings)
16.02 PARAMETER LOCK	(0) OPEN; (65535) LOCKED	252	41602	(see Alternative Settings)
16.03 PASS CODE	0 ... 30000	253	41603	1 = 1
16.04 FAULT RESET SEL	(1) NOT SEL; (2) DI1; (3) DI2; (4) DI3; (5) DI4; (6) DI5; (7) DI6; (8) ON STOP; (9) COMM. MODULE; (10) DI7; (11) DI8; (12) DI9; (13) DI10; (14) DI11; (15) DI12	254	41604	(see Alternative Settings)
16.05 USER MACRO IO CHG	(1) NOT SEL; (2) DI1; (3) DI2; (4) DI3; (5) DI4; (6) DI5; (7) DI6; (8) DI7; (9) DI8; (10) DI9; (11) DI10; (12) DI11; (13) DI12	255	41605	(see Alternative Settings)
16.06 LOCAL LOCK	(0) OFF; (65535) ON	256	41606	(see Alternative Settings)
16.07 PARAM SAVE	(0) DONE; (1) SAVE..	257	41607	(see Alternative Settings)
<b>20 LIMITS</b>				
20.01 MINIMUM SPEED	-18000/(number of pole pairs) rpm ... 20.2 MAXIMUM SPEED	351	42001	1 = 1 rpm
20.02 MAXIMUM SPEED	20.1 MINIMUM SPEED ... 18000/(number of pole pairs) rpm	352	42002	1 = 1 rpm
20.03 MAXIMUM CURRENT	0.0 % $I_{hd}$ ... 200.0 % $I_{hd}$	353	42003	0 = 0 % 20000 = 200 %
20.04 MAXIMUM TORQUE	0.0 % ... 600.0 %	354	42004	100 = 1 %
20.05 OVERVOLTAGE CTRL	(0) NO; (65535) YES	355	42005	(see Alternative Settings)
20.06 UNDERVOLTAGE CTRL	(0) NO; (65535) YES	356	42006	(see Alternative Settings)
20.07 MINIMUM FREQ	-300.00 Hz ... 50 Hz (visible only when the SCALAR motor control mode is selected)	357	42007	-30000 = -300 Hz 5000 = 50 Hz
20.08 MAXIMUM FREQ	-50 Hz ... 300.00 Hz (visible only when the SCALAR motor control mode is selected)	358	42008	-5000 = -50 Hz 30000 = 300 Hz
20.09 MIN TORQ SELECTOR	(0) -MAX TORQ; (65535) SET MIN TORQ	359	42009	(see Alternative Settings)
20.10 SET MIN TORQUE	-600.0 % ... 0.0 %	360	42010	100 = 1 %
20.11 P MOTORING LIMIT	0% ... 600%	361	42011	100 = 1 %
20.12 P GENERATING LIMIT	-600% ... 0%	362	42012	100 = 1 %
<b>21 START/STOP</b>				
21.01 START FUNCTION	(1) AUTO; (2) DC MAGN; (3) CNST DC MAGN	376	42101	(see Alternative Settings)
21.02 CONST MAGN TIME	30.0 ms ... 10000.0 ms	377	42102	1 = 1 ms
21.03 STOP FUNCTION	(1) COAST; (2) RAMP	378	42103	(see Alternative Settings)

Appendix A – Complete Parameter Settings

Parameter	Alternative Settings ( ) Fieldbus Equivalent	PROFIBUS Par. No. (Add 4000 in FMS Mode)	Modbus/ Modbus Plus Par. No.	Scaling for Fieldbus
21.04 DC HOLD	(0) NO; (65535) YES	379	42104	(see Alternative Settings)
21.05 DC HOLD SPEED	0 rpm ... 3000 rpm	380	42105	1 = 1 rpm
21.06 DC HOLD CURR	0 % ... 100 %	381	42106	1 = 1 %
21.07 RUN ENABLE FUNC	(1) RAMP STOP; (2) COAST STOP; (3) OFF2 STOP; (4) OFF3 STOP	382	42107	(see Alternative Settings)
21.08 SCALAR FLY START	(0) NO; (1) YES	383	42108	
<b>22 ACCEL/DECEL</b>				
22.01 ACC/DEC 1/2 SEL	(1) ACC/DEC 1; (2) ACC/DEC 2; (3) DI1; (4) DI2; (5) DI3; (6) DI4; (7) DI5; (8) DI6; (9) DI7; (10) DI8; (11) DI9; (12) DI10; (13) DI11; (14) DI12	401	42201	(see Alternative Settings)
22.02 ACCEL TIME 1	0.00 s ... 1800.00 s	402	42202	0 = 0 s 18000 = 1800 s
22.03 DECEL TIME 1	0.00 s ... 1800.00 s	403	42203	
22.04 ACCEL TIME 2	0.00 s ... 1800.00 s	404	42204	
22.05 DECEL TIME 2	0.00 s ... 1800.00 s	405	42205	
22.06 ACC/DEC RAMP SHPE	0.00 s ... 1000.00 s	406	42206	100 = 1 s
22.07 EM STOP RAMP TIME	0.00 s ... 2000.00 s	407	42207	100 = 1 s
<b>23 SPEED CTRL</b> Visible only with 99.04 MOTOR CTRL MODE = DTC				
23.01 GAIN	0.0 ... 200.0	426	42301	0 = 0 10000 = 100
23.02 INTEGRATION TIME	0.01 s ... 999.97 s	427	42302	1000 = 1 s
23.03 DERIVATION TIME	0.0 ms ... 9999.8 ms	428	42303	1 = 1 ms
23.04 ACC COMPENSATION	0.00 s ... 999.98 s	429	42304	0 = 0 s 1 = 0.1 s
23.05 SLIP GAIN	0.0 % ... 400.0 %	430	42305	1 = 1 %
23.06 AUTOTUNE RUN	(0) NO; (65535) YES	431	42306	(see Alternative Settings)
<b>24 TORQUE CTRL</b> (Visible with 99.02 APPLICATION MACRO = T CTRL)				
24.01 TORQ RAMP UP	0.00 s ... 120.00 s	451	42401	0 = 0 s 100 = 1 s
24.02 TORQ RAMP DOWN	0.00 s ... 120.00 s	452	42402	
<b>25 CRITICAL SPEEDS</b>				
25.01 CRIT SPEED SELECT	(0) OFF; (65535) ON	476	42501	(see Alternative Settings)
25.02 CRIT SPEED 1 LOW	0 rpm ... 18000 rpm	477	42502	1 = 1 rpm
25.03 CRIT SPEED 1 HIGH	0 rpm ... 18000 rpm	478	42503	
25.04 CRIT SPEED 2 LOW	0 rpm ... 18000 rpm	479	42504	
25.05 CRIT SPEED 2 HIGH	0 rpm ... 18000 rpm	480	42505	
25.06 CRIT SPEED 3 LOW	0 rpm ... 18000 rpm	481	42506	
25.07 CRIT SPEED 3 HIGH	0 rpm ... 18000 rpm	482	42507	
<b>26 MOTOR CONTROL</b>				
26.01 FLUX OPTIMIZATION	(0) NO; (65535) YES	501	42601	(see Alternative Settings)
26.02 FLUX BRAKING	(0) NO; (65535) YES	502	42602	(see Alternative Settings)
26.03 IR COMPENSATION	0 % ... 30 % (visible only with 99.04 MOTOR CTRL MODE set to SCALAR)	503	42603	100 = 1 %
26.05 HEX FIELD WEAKEN	(0) NO; (1) YES	504	42605	

Parameter	Alternative Settings ( ) Fieldbus Equivalent	PROFIBUS Par. No. (Add 4000 in FMS Mode)	Modbus/ Modbus Plus Par. No.	Scaling for Fieldbus
<b>30 FAULT FUNCTIONS</b>				
30.01 AI<MIN FUNCTION	(1) FAULT; (2) NO; (3) CONST SP 15; (4) LAST SPEED	601	43001	(see Alternative Settings)
30.02 PANEL LOSS	(1) FAULT; (2) CONST SP 15; (3) LAST SPEED	602	43002	(see Alternative Settings)
30.03 EXTERNAL FAULT	(1) NOT SEL; (2) DI1; (3) DI2; (4) DI3; (5) DI4; (6) DI5; (7) DI6; (8) DI7; (9) DI8; (10) DI9; (11) DI10; (12) DI11; (13) DI12	603	43003	(see Alternative Settings)
30.04 MOTOR THERM PROT	(1) FAULT; (2) WARNING; (3) NO	604	43004	(see Alternative Settings)
30.05 MOT THERM P MODE	(1) DTC; (2) USER MODE; (3) THERMISTOR	605	43005	(see Alternative Settings)
30.06 MOTOR THERM TIME	256.0 s ... 9999.8 s	606	43006	1 = 1 s
30.07 MOTOR LOAD CURVE	50.0 % ... 150.0 %	607	43007	1 = 1 %
30.08 ZERO SPEED LOAD	25.0 % ... 150.0 %	608	43008	1 = 1 %
30.09 BREAK POINT	1.0 Hz ... 300.0 Hz	609	43009	100 = 1 Hz 30000 = 300 Hz
30.10 STALL FUNCTION	(1) FAULT; (2) WARNING; (3) NO	610	43010	(see Alternative Settings)
30.11 STALL FREQ HI	0.5 Hz ... 50.0 Hz	611	43011	50 = 0.5 Hz 5000 = 50 Hz
30.12 STALL TIME	10.00 s ... 400.00 s	612	43012	1 = 1 s
30.13 UNDERLOAD FUNC	(1) NO; (2) WARNING; (3) FAULT	613	43013	(see Alternative Settings)
30.14 UNDERLOAD TIME	0 s ... 600 s	614	43014	1 = 1 s
30.15 UNDERLOAD CURVE	1 ... 5	615	43015	(see Alternative Settings)
30.16 MOTOR PHASE LOSS	(0) NO; (65535) FAULT	616	43016	(see Alternative Settings)
30.17 EARTH FAULT	(0) WARNING; (65535) FAULT	617	43017	(see Alternative Settings)
30.18 COMM FAULT FUNC	(1) FAULT; (2) NO; (3) CONST SP 15; (4) LAST SPEED	618	43018	(see Alternative Settings)
30.19 MAIN ERF DS T-OUT	0.1 s ... 60.0 s	619	43019	10 = 0.1 s 6000 = 60 s
30.20 COMM FAULT RO/AO	(0) ZERO; (65535) LAST VALUE	620	43020	(see Alternative Settings)
30.21 AUX DS T-OUT	0.1 s ... 60.0 s	621	43021	10 = 0.1 s 6000 = 60 s
30.22 IO CONF FUNC	(1) NO; (2) WARNING	622	43022	(see Alternative Settings)
<b>31 AUTOMATIC RESET</b>				
31.01 NUMBER OF TRIALS	0 ... 5	626	43101	
31.02 TRIAL TIME	1.0 s ... 180.0 s	627	43102	100 = 1 s 18000 = 180 s
31.03 DELAY TIME	0.0 s ... 3.0 s	628	43103	0 = 0 s 300 = 3 s
31.04 OVERCURRENT	(0) NO; (65535) YES	629	43104	(see Alternative Settings)
31.05 OVERVOLTAGE	(0) NO; (65535) YES	630	43105	(see Alternative Settings)
31.06 UNDERVOLTAGE	(0) NO; (65535) YES	631	43106	(see Alternative Settings)
31.07 AI SIGNAL<MIN	(0) NO; (65535) YES	632	43107	(see Alternative Settings)
<b>32 SUPERVISION</b>				
32.01 SPEED1 FUNCTION	(1) NO; (2) LOW LIMIT; (3) HIGH LIMIT; (4) ABS LOW LIMIT	651	43201	(see Alternative Settings)
32.02 SPEED1 LIMIT	- 18000 rpm ... 18000 rpm	652	43202	1 = 1 rpm
32.03 SPEED2 FUNCTION	(1) NO; (2) LOW LIMIT; (3) HIGH LIMIT; (4) ABS LOW LIMIT	653	43203	(see Alternative Settings)
32.04 SPEED2 LIMIT	- 18000 rpm ... 18000 rpm	654	43204	1 = 1 rpm
32.05 CURRENT FUNCTION	(1) NO; (2) LOW LIMIT; (3) HIGH LIMIT	655	43205	(see Alternative Settings)
32.06 CURRENT LIMIT	0 ... 1000 A	656	43206	1 = 1 A

Appendix A – Complete Parameter Settings

Parameter	Alternative Settings ( ) Fieldbus Equivalent	PROFIBUS Par. No. (Add 4000 in FMS Mode)	Modbus/ Modbus Plus Par. No.	Scaling for Fieldbus
32.07 TORQUE 1 FUNCTION	(1) NO; (2) LOW LIMIT; (3) HIGH LIMIT	657	43207	(see <b>Alternative Settings</b> )
32.08 TORQUE 1 LIMIT	-400 % ... 400 %	658	43208	10 = 1 %
32.09 TORQUE 2 FUNCTION	(1) NO; (2) LOW LIMIT; (3) HIGH LIMIT	659	43209	(see <b>Alternative Settings</b> )
32.10 TORQUE 2 LIMIT	-400 % ... 400 %	660	43210	10 = 1 %
32.11 REF1 FUNCTION	(1) NO; (2) LOW LIMIT; (3) HIGH LIMIT	661	43211	(see <b>Alternative Settings</b> )
32.12 REF1 LIMIT	0 rpm ... 18000 rpm	662	43212	1 = 1 rpm
32.13 REF2 FUNCTION	(1) NO; (2) LOW LIMIT; (3) HIGH LIMIT	663	43213	(see <b>Alternative Settings</b> )
32.14 REF2 LIMIT	0 % ... 500 %	664	43214	10 = 1 %
32.15 ACT1 FUNCTION	(1) NO; (2) LOW LIMIT; (3) HIGH LIMIT	665	43215	(see <b>Alternative Settings</b> )
32.16 ACT1 LIMIT	0 % ... 200 %	666	43216	0 = 0 % 10 = 1 %
32.17 ACT2 FUNCTION	(1) NO; (2) LOW LIMIT; (3) HIGH LIMIT	667	43217	(see <b>Alternative Settings</b> )
32.18 ACT2 LIMIT	0 % ... 200 %	668	43218	0 = 0 % 10 = 1 %
<b>33 INFORMATION</b>				
33.01 SOFTWARE VERSION	(Version of the ACS 600 software)	676	43301	
33.02 APPL SW VERSION	(Version of the ACS 600 software)	677	43302	
33.03 TEST DATE	(Date Tested)	678	43303	
<b>34 PROCESS VARIABLE</b>				
34.01 SCALE	0.00 ... 100000.00	701	43401	1 = 1
34.02 P VAR UNIT	(1) NO; (2) rpm; (3) %; (4) m/s; (5) A; (6) V; (7) Hz; (8) s; (9) h; (10) kh; (11) C; (12) lft; (13) mA; (14) mV; (15) kW; (16) W; (17) kWh; (18) F; (19) hp; (20) MWh; (21) m3h; (22) l/s; (23) bar; (24) kPa; (25) GPM; (26) PSI; (27) CFM; (28) ft; (29) MGD; (30) iHg; (31) FPM;	702	43402	(see <b>Alternative Settings</b> )
34.03 SELECT P VAR	0 to 9999	703	43403	
34.04 MOTOR SP FILT TIM	0 to 20000 ms	704	43404	1 = 1
34.05 TORQ ACT FILT TIM	0. to 20000 ms	705	43405	1 = 1
34.06 RESET RUN TIME	(0) NO; (65535) YES	706	43406	(see <b>Alternative Settings</b> )
<b>35 MOT TEMP MEAS</b>				
35.01 MOT 1 TEMP AI1 SEL	(1) NOT IN USE; (2) 1XPT100; (3) 2XPT100, (4) 3XPT100, (5) 1..3 PTC	726	43501	(see <b>Alternative Settings</b> )
35.02 MOT 1 TEMP ALM L	-10 to 5000 ohm/°C (PTC/Pt100)	727	43502	1 = 1
35.03 MOT 1 TEMP FLT L	-10 to 5000 ohm/°C (PTC/Pt100)	728	43503	1 = 1
35.04 MOT 2 TEMP AI2 SEL	(1) NOT IN USE; (2) 1XPT100; (3) 2XPT100; (4) 3XPT100; (5) 1..3 PTC	729	43504	(see <b>Alternative Settings</b> )
35.05 MOT 2 TEMP ALM L	-10 ... 180°C (Pt 100) or 0 ... 5000 ohm (PTC)	730	43505	1 = 1
35.06 MOT 2 TEMP FLT L	-10 ... 180°C (Pt 100) or 0 ... 5000 ohm (PTC)	731	43506	1 = 1
35.07 MOT MOD COMPENSAT	(1) NO; (0) YES	732	43507	(see <b>Alternative Settings</b> )
<b>40 PID CONTROL</b>				
40.01 PID GAIN	(40.14 TRIM MODE to 40.18 TRIM SELECTION: not visible with 99.02 APPLICATION MACRO = PID CTRL, 40.18 TRIM SELECTION: visible only when 99.02 APPLICATION MACRO = T CTRL, 40.20 SLEEP SELECTION to 40.24 WAKE UP DELAY: visible only when 99.02 APPLICATION MACRO = PID CTRL)	851	44001	10 = 0.1 10000 = 100

Parameter	Alternative Settings ( ) Fieldbus Equivalent	PROFIBUS Par. No. (Add 4000 in FMS Mode)	Modbus/ Modbus Plus Par. No.	Scaling for Fieldbus
40.02 PID INTEG TIME	0.02 s ... 320.00 s	852	44002	2 = 0.02 s 32000 = 320 s
40.03 PID DERIV TIME	0.00 s ... 10.00 s	853	44003	0 = 0 s 1000 = 10 s
40.04 PID DERIV FILTER	0.04 s ... 10.00 s	854	44004	4 = 0.04 s 1000 = 10 s
40.05 ERROR VALUE INV	(0) NO; (65535) YES	855	44005	(see Alternative Settings)
40.06 ACTUAL VALUE SEL	(1) ACT1; (2) ACT1 - ACT2; (3) ACT1 + ACT2; (4) ACT1 * ACT2; (5) ACT1/ACT2; (6) MIN(A1,A2); (7) MAX(A1,A2); (8) sqrt(A1 - A2); (9) sqA1 + sqA2	856	44006	(see Alternative Settings)
40.07 ACTUAL1 INPUT SEL	(1) AI1; (2) AI2; (3) AI3; (4) AI5; (5) AI6; (6) CURRENT; (7) TORQUE; (8) POWER	857	44007	(see Alternative Settings)
40.08 ACTUAL2 INPUT SEL	(1) AI1; (2) AI2; (3) AI3; (4) AI5; (5) AI6; (6) CURRENT; (7) TORQUE; (8) POWER	858	44008	(see Alternative Settings)
40.09 ACT1 MINIMUM	-1000 % ... 1000 %	859	44009	-10000 = -1000 % 10000 = 1000 %
40.10 ACT1 MAXIMUM	-1000 % ... 1000 %	860	44010	
40.11 ACT2 MINIMUM	-1000 % ... 1000 %	861	44011	
40.12 ACT2 MAXIMUM	-1000 % ... 1000 %	862	44012	
40.13 PID INTEGRATION	(1) OFF; (2) ON	863	44013	(see Alternative Settings)
40.14 TRIM MODE	(1) OFF; (2) PROPORTIONAL; (3) DIRECT	864	44014	(see Alternative Settings)
40.15 TRIM REF SEL	(1) AI1; (2) AI2; (3) AI3; (4) AI5; (5) AI6; (6) PAR 40.16	865	44015	(see Alternative Settings)
40.16 TRIM REFERENCE	-100.0% to 100.0%	866	44016	100 = 1%
40.17 TRIM RANGE ADJUST	-100.0% to 100.0%	867	44017	100 = 1%
40.18 TRIM SELECTION	(1) SPEED TRIM; (2) TORQUE TRIM	868	44018	(see Alternative Settings)
40.19 ACTUAL FILT TIME	0.04 s to 10.00s	869	44019	100 = 1 s
40.20 SLEEP SELECTION	(1) OFF; (2) INTERNAL; (3) DI1; (4) DI2; (5) DI3; (6) DI4; (7) DI5; (8) DI6; (9) DI7; (10) DI8; (11) DI9; (12) DI10; (13) DI11; (14) DI12	870	44020	(see Alternative Settings)
40.21 SLEEP LEVEL	0.0 to 7200.0 rpm	871	44021	1 = 1 rpm
40.22 SLEEP DELAY	0.0 s to 3600.0 s	872	44022	10 = 1 s
40.23 WAKE UP LEVEL	0.0 % to 100.0 %	873	44023	100 = 1%
40.24 WAKE UP DELAY	0.0 s to 3600.0 s	874	44024	10 = 1 s
<b>42 BRAKE CONTROL</b>	(Not accessible from Profibus)			
42.01 BRAKE CTRL	(1) OFF; (2) ON	-	44201	(see Alternative Settings)
42.02 BRAKE ACKNOWLEDGE	(1) OFF; (2) DI5; (3) DI6; (4) DI11; (5) DI12	-	44202	(see Alternative Settings)
42.03 BRAKE OPEN DELAY	0.0 to 5.0 s	-	44203	100 = 1 s
42.04 BRAKE CLOSE DELAY	0.0 to 60.0 s	-	44204	100 = 1 s
42.05 ABS BRAKE CLS SPD	0 to 1000 rpm	-	44205	100 = 1 rpm
42.06 BRAKE FAULT FUNC	(1) FAULT; (2) WARNING	-	44206	(see Alternative Settings)
42.07 START TORQ REF SEL	(1) NO; (2) AI1; (3) AI2; (4) AI3; (5) AI5; (6) AI6; (7) PAR 42.08	-	44207	(see Alternative Settings)
42.08 START TORQ REF	-300 to 300%	-	44208	100 = 1%
<b>Group 45 FUNCTION SELECTION</b>	(Not accessible from Profibus)			
45.01 POINTER1 GRP+IND	-9999 to 9999	-		1 = 1
45.02 POINTER1 BIT	0 to 15	-		1 = 1
45.03 POINTER2 GRP+IND	-9999 to 9999	-		1 = 1

Appendix A – Complete Parameter Settings

Parameter	Alternative Settings ( ) Fieldbus Equivalent	PROFIBUS Par. No. (Add 4000 in FMS Mode)	Modbus/ Modbus Plus Par. No.	Scaling for Fieldbus
45.04 POINTER2 BIT	0 to 15	-		1 = 1
45.05 POINTER3 GRP+IND	-9999 to 9999	-		1 = 1
45.06 POINTER3 BIT	0 to 15	-		1 = 1
45.07 POINTER4 GRP+IND	-9999 to 9999	-		1 = 1
45.08 POINTER4 BIT	0 to 15	-		1 = 1
45.09 POINTER5 GRP+IND	-9999 to 9999	-		1 = 1
45.10 POINTER5 BIT	0 to 15	-		1 = 1
45.11 POINTER6 GRP+IND	-9999 to 9999	-		1 = 1
45.12 POINTER6 BIT	0 to 15	-		1 = 1
<b>50 ENCODER MODULE</b>	(Visible with 98.01 ENCODER MODULE set.)			
50.01 PULSE NR	0 ... 29999	1001	45001	1 = 1 ppr
50.02 SPEED MEAS MODE	(1) A . B DIR ; (2) A . ; (3) A . B DIR ; (4) A . B .	1002	45002	(see Alternative Settings)
50.03 ENCODER FAULT	(0) WARNING; (65535) FAULT	1003	45003	(see Alternative Settings)
50.04 ENCODER DELAY	5 ms... 50000 ms	1004	45004	1 = 1 ms
50.05 ENCODER CHANNEL	(1) CHANNEL1; (2) CHANNEL 2	1005	45005	(see Alternative Settings)
50.06 SPEED FB SEL	(0) INTERNAL; (65535) ENCODER	1006	45006	(see Alternative Settings)
<b>51 COMMUNICATION MODULE</b>	(Visible with 98.02 COMM. MODULE LINK set. See module manual.)	1026 ...	45101 ...	
<b>52 STANDARD MODBUS</b>				
52.01 STATION NUMBER	1 to 247	1051	45201	(see Alternative Settings)
52.02 BAUDRATE	(1) 600; (2) 1200; (3) 2400; (4) 4800; (5) 9600; (6) 19200	1052	45202	(see Alternative Settings)
52.03 PARITY	(1) NONE1STOPBIT; (2) NONE2STOPBIT; (3) ODD; (4) EVEN	1053	45203	(see Alternative Settings)
<b>60 MASTER/FOLLOWER</b>				
60.01 MASTER LINK MODE	(1) NOT IN USE; (2) MASTER; (3) FOLLOWER	1195	46001	(see Alternative Settings)
60.02 TORQUE SELECTOR	(1) SPEED; (2) TORQUE; (3) MINIMUM; (4) MAXIMUM; (5) ADD; (6) ZERO (Visible if 99.02 APPLICATION MACRO is T CTRL)	1196	46002	
60.03 WINDOW SEL ON	(0) NO; (65535) YES (Visible if 99.02 APPLICATION MACRO is T CTRL)	1167	46003	(see Alternative Settings)
60.04 WINDOW WIDTH POS	0 to 1500 (Visible if 99.02 APPLICATION MACRO is T CTRL)	1198	46004	20000 = 1500
60.05 WINDOW WIDTH NEG	0 to 1500 (Visible if 99.02 APPLICATION MACRO is T CTRL)	1199	46005	20000 = 1500
60.06 DROOP RATE	0 to 100%	1200	46006	10 = 1%
60.07 MASTER SIGNAL 2	0000 to 9999	1201	46007	1 = 1
60.08 MASTER SIGNAL 3	0000 to 9999	1202	46008	1 = 1
<b>70 DDCS CONTROL</b>				
70.01 CHANNEL 0 ADDR	1 ... 125	1375	47001	(see Alternative Settings)
70.02 CHANNEL 3 ADDR	1 ... 254	1376	47002	(see Alternative Settings)
70.03 CH1 BAUDRATE	(0) 8Mbits; (1) 4 Mbits; (2) 2 Mbits; (3) 1 Mbits	1377	47003	(see Alternative Settings)
<b>90 D SET REC ADDR</b>				
90.01 AUX DS REF3	0 ... 8999 (Format: (X)XYY, where (X)X = Parameter Group, YY = Parameter Index)	1735	49001	(see Alternative Settings)

Parameter	Alternative Settings ( ) Fieldbus Equivalent	PROFIBUS Par. No. (Add 4000 in FMS Mode)	Modbus/ Modbus Plus Par. No.	Scaling for Fieldbus
90.02 AUX DS REF4	0 ... 8999 (Format: (X)XYY, where (X)X = Parameter Group, YY = Parameter Index)	1736	49002	(see Alternative Settings)
90.03 AUX DS REF5	0 ... 8999 (Format: (X)XYY, where (X)X = Parameter Group, YY = Parameter Index)	1737	49003	(see Alternative Settings)
90.04 MAIN DS SOURCE	1 ... 255	1738	49004	(see Alternative Settings)
90.05 AUX DS SOURCE	1 ... 255	1739	49005	(see Alternative Settings)
<b>92 D SET TR ADDR</b>				
92.01 MAIN DS STATUS WORD	Fixed to 302 (MAIN STATUS WORD), not visible	1771	49201	(see Alternative Settings)
92.02 MAIN DS ACT1	0 ... 9999 (Format: (X)XYY, where (X)X = Parameter Group, YY = Parameter Index)	1772	49202	(see Alternative Settings)
92.03 MAIN DS ACT2	0 ... 9999 (Format: (X)XYY, where (X)X = Parameter Group, YY = Parameter Index)	1773	49203	(see Alternative Settings)
92.04 AUX DS ACT3	0 ... 9999 (Format: (X)XYY, where (X)X = Parameter Group, YY = Parameter Index)	1774	49204	(see Alternative Settings)
92.05 AUX DS ACT4	0 ... 9999 (Format: (X)XYY, where (X)X = Parameter Group, YY = Parameter Index)	1775	49205	(see Alternative Settings)
92.06 AUX DS ACT5	0 ... 9999 (Format: (X)XYY, where (X)X = Parameter Group, YY = Parameter Index)	1776	49206	(see Alternative Settings)
<b>96 EXTERNAL AO</b>				
	(Visible with 98.06 AI/O EXT MODULE set to UNIPOLAR PRG or BIPOLAR PRG)			
96.01 EXT AO1	(1) NOT USED; (2) P SPEED; (3) SPEED; (4) FREQUENCY; (5) CURRENT; (6) TORQUE; (7) POWER; (8) DC BUS VOLT; (9) OUTPUT VOLT; (10) APPL OUTPUT; (11) REFERENCE; (12) CONTROL DEV; (13) ACTUAL 1; (14) ACTUAL 2; (15) COMM. MODULE	1843	49601	(see Alternative Settings)
96.02 INVERT EXT AO1	(0) NO; (65535) YES	1844	49602	(see Alternative Settings)
96.03 MINIMUM EXT AO1	(1) 0 mA; (2) 4 mA; (3) 10mA	1845	49603	(see Alternative Settings)
96.04 FILTER EXT AO1	0.00 s ... 10.00 s	1846	49604	0 = 0 s 1000 = 10 s
96.05 SCALE EXT AO1	10 % ... 1000 %	1847	49605	100 = 10 % 10000 = 1000 %
96.06 EXT AO2	(1) NOT USED; (2) P SPEED; (3) SPEED; (4) FREQUENCY; (5) CURRENT; (6) TORQUE; (7) POWER; (8) DC BUS VOLT; (9) OUTPUT VOLT; (10) APPL OUTPUT; (11) REFERENCE; (12) CONTROL DEV; (13) ACTUAL 1; (14) ACTUAL 2; (15) COMM. MODULE	1848	49606	(see Alternative Settings)
96.07 INVERT EXT AO2	(0) NO; (65535) YES	1849	49607	(see Alternative Settings)
96.08 MINIMUM EXT AO2	(1) 0 mA; (2) 4 mA; (3) 10mA	1850	49608	(see Alternative Settings)
96.09 FILTER EXT AO2	0.00 s ... 10.00 s	1851	49609	0 = 0 s 1000 = 10 s
96.10 SCALE EXT AO2	10 % ... 1000 %	1852	49610	100 = 10 % 10000 = 1000 %
<b>98 OPTION MODULES</b>				
98.01 ENCODER MODULE	(0) NO; (65535) YES	1901	49801	(see Alternative Settings)
98.02 COMM. MODULE LINK	(1) NO; (2) FIELDBUS; (3) ADVANT; (4) STD MODBUS; (5) CUSTOMISED	1902	49802	(see Alternative Settings)
98.03 DI/O EXT MODULE 1	(0) NO; (65535) YES	1903	49803	(see Alternative Settings)
98.04 DI/O EXT MODULE 2	(0) NO; (65535) YES	1904	49804	(see Alternative Settings)
98.05 DI/O EXT MODULE 3	(0) NO; (65535) YES	1905	49805	(see Alternative Settings)

Appendix A – Complete Parameter Settings

Parameter	Alternative Settings ( ) Fieldbus Equivalent	PROFIBUS Par. No. (Add 4000 in FMS Mode)	Modbus/ Modbus Plus Par. No.	Scaling for Fieldbus
98.06 AI/O EXT MODULE	(1) NO; (2) UNIPOLAR; (3) BIPOLAR; (4) UNIP AO PRG; (5) BIP AO PRG; (6) UNIP AIO PRG; (7) BIP AIO PRG	1906	49806	(see <b>Alternative Settings</b> )
98.07 COMM PROFILE	(0) ABB DRIVES; (65535) CSA2.8/3.0 (visible only when Parameter 98.02 COMM. MODULE LINK is activated)	1907	49807	(see <b>Alternative Settings</b> )
98.08 NIOC-01 BOARD	(1) NO; (2) YES	1908	49808	(see <b>Alternative Settings</b> )
98.09 NDIO1 DI FUNC	(1) DI7,8; (2) REPL DI1,2	1909	49809	(see <b>Alternative Settings</b> )
98.10 NDIO2 DI FUNC	(1) DI9,10; (2) REPL DI3,4	1910	49810	(see <b>Alternative Settings</b> )
98.11 NDIO3 DI FUNC	(1) DI11,12; (2) REPL DI3,4	1911	49811	(see <b>Alternative Settings</b> )
98.12 AI/O MOTOR TEMP	(1) NO; (2) UNIPOLAR	1912	49812	(see <b>Alternative Settings</b> )



## Appendix B – Default Settings of Application Macros

The table in this appendix lists all the default parameter settings of all the ACS 600 Application Macros. Use this table as reference when you are selecting and customizing macros for your ACS 600 application.

Table B-1 Default parameter settings of ACS 600 Application Macros.

Parameter	Factory	Hand/Auto	PID Control	Torque Control	Sequential Control	Custom Setting
<b>ACTUAL SIGNALS</b>	(THREE DEFAULT SIGNALS IN THE ACTUAL SIGNAL DISPLAY MODE OF THE CONTROL PANEL)					
	FREQ	FREQ	SPEED	SPEED	FREQ	
	CURRENT	CURRENT	ACT VAL1	TORQUE	CURRENT	
	POWER	CTRL LOC	CONT DEV	CTRL LOC	POWER	
<b>99 START-UP DATA</b>						
99.01 LANGUAGE	ENGLISH	ENGLISH	ENGLISH	ENGLISH	ENGLISH	
99.02 APPLICATION MACRO	FACTORY	HAND/AUTO	PID-CTRL	T CTRL	SEQ CTRL	
99.03 APPLIC RESTORE	NO	NO	NO	NO	NO	
99.04 MOTOR CTRL MODE	DTC	DTC	DTC	DTC	DTC	
99.05 MOTOR NOM VOLTAGE	0 V	0 V	0 V	0 V	0 V	
99.06 MOTOR NOM CURRENT	0.0 A	0.0 A	0.0 A	0.0 A	0.0 A	
99.07 MOTOR NOM FREQ	50.0 Hz	50.0 Hz	50.0 Hz	50.0 Hz	50.0 Hz	
99.08 MOTOR NOM SPEED	1 rpm	1 rpm	1 rpm	1 rpm	1 rpm	
99.09 MOTOR NOM POWER	0.0 kW	0.0 kW	0.0 kW	0.0 kW	0.0 kW	
99.10 MOTOR ID RUN	NO	NO	NO	NO	NO	
<b>10 START/STOP/DIR</b>						
10.01 EXT1 STRT/STP/DIR	DI1,2	DI1,2	DI1	DI1,2	DI1,2	
10.02 EXT2 STRT/STP/DIR	NOT SEL	DI6,5	DI6	DI1,2	NOT SEL	
10.03 DIRECTION	FORWARD	REQUEST	FORWARD	REQUEST	REQUEST	
<b>11 REFERENCE SELECT</b>						
11.01 KEYPAD REF SEL	REF1 (rpm)	REF1 (rpm)	REF1 (rpm)	REF1 (rpm)	REF1 (rpm)	
11.02 EXT1/EXT2 SELECT	EXT1	DI3	DI3	DI3	EXT1	
11.03 EXT REF1 SELECT	AI1	AI1	AI1	AI1	AI1	
11.04 EXT REF1 MINIMUM	0 rpm	0 rpm	0 rpm	0 rpm	0 rpm	
11.05 EXT REF1 MAXIMUM	1500 rpm	1500 rpm	1500 rpm	1500 rpm	1500 rpm	
11.06 EXT REF2 SELECT	KEYPAD	AI2	AI1	AI2	AI1	
11.07 EXT REF2 MINIMUM	0 %	0 %	0 %	0 %	0 %	
11.08 EXT REF2 MAXIMUM	100 %	100 %	100 %	100 %	100 %	

Appendix B – Default Settings of Application Macros

Parameter	Factory	Hand/Auto	PID Control	Torque Control	Sequential Control	Custom Setting
<b>12 CONSTANT SPEEDS</b>						
12.01 CONST SPEED SEL	DI5,6	DI4(SPEED4)	DI4(SPEED4)	DI4(SPEED4)	DI4,5,6	
12.02 CONST SPEED 1	300 rpm	300 rpm	300 rpm	300 rpm	300 rpm	
12.03 CONST SPEED 2	600 rpm	600 rpm	600 rpm	600 rpm	600 rpm	
12.04 CONST SPEED 3	900 rpm	900 rpm	900 rpm	900 rpm	900 rpm	
12.05 CONST SPEED 4	300 rpm	300 rpm	300 rpm	300 rpm	1200 rpm	
12.06 CONST SPEED 5	0 rpm	0 rpm	0 rpm	0 rpm	1500 rpm	
12.07 CONST SPEED 6	0 rpm	0 rpm	0 rpm	0 rpm	2400 rpm	
12.08 CONST SPEED 7	0 rpm	0 rpm	0 rpm	0 rpm	3000 rpm	
12.09 CONST SPEED 8	0 rpm	0 rpm	0 rpm	0 rpm	0 rpm	
12.10 CONST SPEED 9	0 rpm	0 rpm	0 rpm	0 rpm	0 rpm	
12.11 CONST SPEED 10	0 rpm	0 rpm	0 rpm	0 rpm	0 rpm	
12.12 CONST SPEED 11	0 rpm	0 rpm	0 rpm	0 rpm	0 rpm	
12.13 CONST SPEED 12	0 rpm	0 rpm	0 rpm	0 rpm	0 rpm	
12.14 CONST SPEED 13	0 rpm	0 rpm	0 rpm	0 rpm	0 rpm	
12.15 CONST SPEED 14	0 rpm	0 rpm	0 rpm	0 rpm	0 rpm	
12.16 CONST SPEED 15	0 rpm	0 rpm	0 rpm	0 rpm	0 rpm	
<b>13 ANALOGUE INPUTS</b>						
13.01 MINIMUM AI1	0 V	0 V	0 V	0 V	0 V	
13.02 MAXIMUM AI1	10 V	10 V	10 V	10 V	10 V	
13.03 SCALE AI1	100 %	100 %	100 %	100 %	100 %	
13.04 FILTER AI1	0.10 s	0.10 s	0.10 s	0.10 s	0.10 s	
13.05 INVERT AI1	NO	NO	NO	NO	NO	
13.06 MINIMUM AI2	0 mA	0 mA	0 mA	0 mA	0 mA	
13.07 MAXIMUM AI2	20 mA	20 mA	20 mA	20 mA	20 mA	
13.08 SCALE AI2	100 %	100 %	100 %	100 %	100 %	
13.09 FILTER AI2	0.10 s	0.10 s	0.10 s	0.10 s	0.10 s	
13.10 INVERT AI2	NO	NO	NO	NO	NO	
13.11 MINIMUM AI3	0 mA	0 mA	0 mA	0 mA	0 mA	
13.12 MAXIMUM AI3	20 mA	20 mA	20 mA	20 mA	20 mA	
13.13 SCALE AI3	100 %	100 %	100 %	100 %	100 %	
13.14 FILTER AI3	0.10 s	0.10 s	0.10 s	0.10 s	0.10 s	
13.15 INVERT AI3	NO	NO	NO	NO	NO	
<b>14 RELAY OUTPUTS</b>						
14.01 RELAY RO1 OUTPUT	READY	READY	READY	READY	READY	
14.02 RELAY RO2 OUTPUT	RUNNING	RUNNING	RUNNING	RUNNING	RUNNING	
14.03 RELAY RO3 OUTPUT	FAULT(-1)	FAULT(-1)	FAULT(-1)	FAULT(-1)	FAULT(-1)	
14.04 RO1 TON DELAY	0.0s	0.0s	0.0s	0.0s	0.0s	
14.05 RO1 TOFF DELAY	0.0s	0.0s	0.0s	0.0s	0.0s	
14.06 RO2 TON DELAY	0.0s	0.0s	0.0s	0.0s	0.0s	
14.07 RO2 TOFF DELAY	0.0s	0.0s	0.0s	0.0s	0.0s	
14.08 RO3 TON DELAY	0.0s	0.0s	0.0s	0.0s	0.0s	
14.09 RO3 TOFF DELAY	0.0s	0.0s	0.0s	0.0s	0.0s	
14.10 NDIO MOD1 RO1	READY	READY	READY	READY	READY	
14.11 NDIO MOD1 RO2	RUNNING	RUNNING	RUNNING	RUNNING	RUNNING	
14.12 NDIO MOD2 RO1	FAULT	FAULT	FAULT	FAULT	FAULT	

Appendix B – Default Settings of Application Macros

Parameter	Factory	Hand/Auto	PID Control	Torque Control	Sequential Control	Custom Setting
14.13 NDIO MOD2 RO2	WARNING	WARNING	WARNING	WARNING	WARNING	
14.14 NDIO MOD3 RO1	REF 2 SEL	REF 2 SEL	REF 2 SEL	REF 2 SEL	REF 2 SEL	
14.15 NDIO MOD3 RO2	AT SPEED	AT SPEED	AT SPEED	AT SPEED	AT SPEED	
<b>15 ANALOGUE OUTPUTS</b>						
15.01 ANALOGUE OUTPUT 1	SPEED	SPEED	SPEED	SPEED	SPEED	
15.02 INVERT AO1	NO	NO	NO	NO	NO	
15.03 MINIMUM AO1	0 mA	0 mA	0 mA	0 mA	0 mA	
15.04 FILTER AO1	0.10 s	0.10 s	0.10 s	0.10 s	0.10 s	
15.05 SCALE AO1	100 %	100 %	100 %	100 %	100 %	
15.06 ANALOGUE OUTPUT 2	CURRENT	CURRENT	CURRENT	CURRENT	CURRENT	
15.07 INVERT AO2	NO	NO	NO	NO	NO	
15.08 MINIMUM AO2	0 mA	0 mA	0 mA	0 mA	0 mA	
15.09 FILTER ON AO2	2.00 s	2.00 s	2.00 s	2.00 s	2.00 s	
15.10 SCALE AO2	100 %	100 %	100 %	100 %	100 %	
<b>16 SYSTEM CONTR INPUTS</b>						
16.01 RUN ENABLE	YES	YES	DI5	DI6	YES	
16.02 PARAMETER LOCK	OPEN	OPEN	OPEN	OPEN	OPEN	
16.03 PASS CODE	0	0	0	0	0	
16.04 FAULT RESET SEL	NOT SEL	NOT SEL	NOT SEL	NOT SEL	NOT SEL	
16.05 USER MACRO IO CHG	NOT SEL	NOT SEL	NOT SEL	NOT SEL	NOT SEL	
16.06 LOCAL LOCK	OFF	OFF	OFF	OFF	OFF	
16.07 PARAM SAVE	DONE	DONE	DONE	DONE	DONE	
<b>20 LIMITS</b>						
20.01 MINIMUM SPEED	(calculated)	(calculated)	(calculated)	(calculated)	(calculated)	
20.02 MAXIMUM SPEED	(calculated)	(calculated)	(calculated)	(calculated)	(calculated)	
20.03 MAXIMUM CURRENT	200.0 % $I_{hd}$	200.0 % $I_{hd}$	200.0 % $I_{hd}$	200.0 % $I_{hd}$	200.0 % $I_{hd}$	
20.04 MAXIMUM TORQUE	300.0 %	300.0 %	300.0 %	300.0 %	300.0 %	
20.05 OVERVOLTAGE CTRL	YES	YES	YES	YES	YES	
20.06 UNDERVOLTAGE CTRL	YES	YES	YES	YES	YES	
20.07 MINIMUM FREQ	- 50 Hz	- 50 Hz	- 50 Hz	- 50 Hz	- 50 Hz	
20.08 MAXIMUM FREQ	50 Hz	50 Hz	50 Hz	50 Hz	50 Hz	
20.09 MIN TORQ SELECTOR	-MAX TORQ	-MAX TORQ	-MAX TORQ	-MAX TORQ	-MAX TORQ	
20.10 SET MIN TORQUE	-300.0 %	-300.0 %	-300.0 %	-300.0 %	-300.0 %	
20.11 P MOTORING LIMIT	300%	300%	300%	300%	300%	
20.12 P GENERATING LIMIT	-300%	-300%	-300%	-300%	-300%	
<b>21 START/STOP</b>						
21.01 START FUNCTION	AUTO	AUTO	AUTO	AUTO	AUTO	
21.02 CONST MAGN TIME	500.0 ms	500.0 ms	500.0 ms	500.0 ms	500.0 ms	
21.03 STOP FUNCTION	COAST	COAST	COAST	COAST	RAMP	
21.04 DC HOLD	NO	NO	NO	NO	NO	
21.05 DC HOLD SPEED	5 rpm	5 rpm	5 rpm	5 rpm	5 rpm	
21.06 DC HOLD CURR	30.0 %	30.0 %	30.0 %	30.0 %	30.0 %	
21.07 RUN ENABLE FUNC	RAMP STOP	RAMP STOP	RAMP STOP	RAMP STOP	RAMP STOP	
21.08 SCALAR FLY START	NO	NO	NO	NO	NO	

Appendix B – Default Settings of Application Macros

Parameter	Factory	Hand/Auto	PID Control	Torque Control	Sequential Control	Custom Setting
<b>22 ACCEL/DECEL</b>						
22.01 ACC/DEC 1/2 SEL	DI4	ACC/DEC 1	ACC/DEC 1	DI5	DI3	
22.02 ACCELER TIME 1	3.00 s	3.00 s	3.00 s	3.00 s	3.00 s	
22.03 DECELER TIME 1	3.00 s	3.00 s	3.00 s	3.00 s	3.00 s	
22.04 ACCELER TIME 2	60.00 s	60.00 s	60.00 s	60.00 s	60.00 s	
22.05 DECELER TIME 2	60.00 s	60.00 s	60.00 s	60.00 s	60.00 s	
22.06 ACC/DEC RAMP SHPE	0.00 s	0.00 s	0.00 s	0.00 s	0.00 s	
22.07 EM STOP RAMP TIME	3.00 s	3.00 s	3.00 s	3.00 s	3.00 s	
<b>23 SPEED CTRL</b>						
23.01 GAIN	10.0	10.0	10.0	10.0	10.0	
23.02 INTEGRATION TIME	2.50 s	2.50 s	2.50 s	2.50 s	2.50 s	
23.03 DERIVATION TIME	0.0 ms	0.0 ms	0.0 ms	0.0 ms	0.0 ms	
23.04 ACC COMPENSATION	0.00 s	0.00 s	0.00 s	0.00 s	0.12 s	
23.05 SLIP GAIN	100.0 %	100.0 %	100.0 %	100.0 %	100.0 %	
23.06 AUTOTUNE RUN	NO	NO	NO	NO	NO	
<b>24 TORQUE CTRL</b>						
24.01 TORQ RAMP UP				0.00 s		
24.02 TORQ RAMP DOWN				0.00 s		
<b>25 CRITICAL SPEEDS</b>						
25.01 CRIT SPEED SELECT	OFF	OFF	-	OFF	OFF	
25.02 CRIT SPEED 1 LOW	0 rpm	0 rpm	-	0 rpm	0 rpm	
25.03 CRIT SPEED 1 HIGH	0 rpm	0 rpm	-	0 rpm	0 rpm	
25.04 CRIT SPEED 2 LOW	0 rpm	0 rpm	-	0 rpm	0 rpm	
25.05 CRIT SPEED 2 HIGH	0 rpm	0 rpm	-	0 rpm	0 rpm	
25.06 CRIT SPEED 3 LOW	0 rpm	0 rpm	-	0 rpm	0 rpm	
25.07 CRIT SPEED 3 HIGH	0 rpm	0 rpm	-	0 rpm	0 rpm	
<b>26 MOTOR CONTROL</b>						
26.01 FLUX OPTIMIZATION	NO	NO	NO	NO	NO	
26.02 FLUX BRAKING	YES	YES	YES	YES	YES	
26.03 IR COMPENSATION	0.0 %	0.0 %	0.0 %	0.0 %	0.0 %	
26.05 HEX FIELD WEAKEN	OFF	OFF	OFF	OFF	OFF	
<b>30 FAULT FUNCTIONS</b>						
30.01 AI<MIN FUNCTION	FAULT	FAULT	FAULT	FAULT	FAULT	
30.02 PANEL LOSS	FAULT	FAULT	FAULT	FAULT	FAULT	
30.03 EXTERNAL FAULT	NOT SEL	NOT SEL	NOT SEL	NOT SEL	NOT SEL	
30.04 MOT THERM PROT	NO	NO	NO	NO	NO	
30.05 MOTOR THERM P MODE	DTC <sup>1)</sup>	DTC <sup>1)</sup>	DTC <sup>1)</sup>	DTC <sup>1)</sup>	DTC <sup>1)</sup>	
30.06 MOTOR THERM TIME	(calculated)	(calculated)	(calculated)	(calculated)	(calculated)	
30.07 MOTOR LOAD CURVE	100.0 %	100.0 %	100.0 %	100.0 %	100.0 %	
30.08 ZERO SPEED LOAD	74.0 %	74.0 %	74.0 %	74.0 %	74.0 %	

Appendix B – Default Settings of Application Macros

Parameter	Factory	Hand/Auto	PID Control	Torque Control	Sequential Control	Custom Setting
30.09 BREAK POINT	45.0 Hz	45.0 Hz	45.0 Hz	45.0 Hz	45.0 Hz	
30.10 STALL FUNCTION	FAULT	FAULT	FAULT	FAULT	FAULT	
30.11 STALL FREQ HI	20.0 Hz	20.0 Hz	20.0 Hz	20.0 Hz	20.0 Hz	
30.12 STALL TIME	20.00 s	20.00 s	20.00 s	20.00 s	20.00 s	
30.13 UNDERLOAD FUNC	NO	NO	NO	NO	NO	
30.14 UNDERLOAD TIME	600.0 s	600.0 s	600.0 s	600.0 s	600.0 s	
30.15 UNDERLOAD CURVE	1	1	1	1	1	
30.16 MOTOR PHASE LOSS	NO	NO	NO	NO	NO	
30.17 EARTH FAULT	FAULT	FAULT	FAULT	FAULT	FAULT	
30.18 COMM FAULT FUNC	FAULT	FAULT	FAULT	FAULT	FAULT	
30.19 MAIN REF DS T-OUT	1.00 s	1.00 s	1.00 s	1.00 s	1.00 s	
30.20 COMM FAULT RO/AO	ZERO	ZERO	ZERO	ZERO	ZERO	
30.21 AUX DS T-OUT	3.0 s	3.0 s	3.0 s	3.0 s	3.0 s	
30.22 IO CONF FUNC	WARNING	WARNING	WARNING	WARNING	WARNING	
<b>31 AUTOMATIC RESET</b>						
31.01 NUMBER OF TRIALS	0	0	0	0	0	
31.02 TRIAL TIME	30.0 s	30.0 s	30.0 s	30.0 s	30.0 s	
31.03 DELAY TIME	0.0 s	0.0 s	0.0 s	0.0 s	0.0 s	
31.04 OVERCURRENT	NO	NO	NO	NO	NO	
31.05 OVERVOLTAGE	NO	NO	NO	NO	NO	
31.06 UNDERVOLTAGE	NO	NO	NO	NO	NO	
31.07 AI SIGNAL<MIN	NO	NO	NO	NO	NO	
<b>32 SUPERVISION</b>						
32.01 SPEED1 FUNCTION	NO	NO	NO	NO	NO	
32.02 SPEED1 LIMIT	0 rpm	0 rpm	0 rpm	0 rpm	0 rpm	
32.03 SPEED2 FUNCTION	NO	NO	NO	NO	NO	
32.04 SPEED2 LIMIT	0 rpm	0 rpm	0 rpm	0 rpm	0 rpm	
32.05 CURRENT FUNCTION	NO	NO	NO	NO	NO	
32.06 CURRENT LIMIT	0 A	0 A	0 A	0 A	0 A	
32.07 TORQUE 1 FUNCTION	NO	NO	NO	NO	NO	
32.08 TORQUE 1 LIMIT	0 %	0 %	0 %	0 %	0 %	
32.09 TORQUE 2 FUNCTION	NO	NO	NO	NO	NO	
32.10 TORQUE 2 LIMIT	0 %	0 %	0 %	0 %	0 %	
32.11 REF1 FUNCTION	NO	NO	NO	NO	NO	
32.12 REF1 LIMIT	0 rpm	0 rpm	0 rpm	0 rpm	0 rpm	
32.13 REF2 FUNCTION	NO	NO	NO	NO	NO	
32.14 REF2 LIMIT	0 %	0 %	0 %	0 %	0 %	
32.15 ACT1 FUNCTION	NO	NO	NO	NO	NO	
32.16 ACT1 LIMIT	0 %	0 %	0 %	0 %	0 %	
32.17 ACT2 FUNCTION	NO	NO	NO	NO	NO	
32.18 ACT2 LIMIT	0 %	0 %	0 %	0 %	0 %	
<b>33 INFORMATION</b>						
33.01 SOFTWARE VERSION	(Version)	(Version)	(Version)	(Version)	(Version)	
33.02 APPL SW VERSION	(Version)	(Version)	(Version)	(Version)	(Version)	
33.03 TEST DATE	(Date)	(Date)	(Date)	(Date)	(Date)	

Appendix B – Default Settings of Application Macros

Parameter	Factory	Hand/Auto	PID Control	Torque Control	Sequential Control	Custom Setting
<b>34 PROCESS VARIABLE</b>						
34.01 SCALE	100.00	100.00	100.00	100.00	100.00	
34.02 P VAR UNIT	%	%	%	%	%	
34.03 SELECT P VAR	142	142	142	142	142	
34.04 MOTOR SP FILT TIM	500 ms	500 ms	500 ms	500 ms	500 ms	
34.05 TORQ ACT FILT TIM	100 ms	100 ms	100 ms	100 ms	100 ms	
34.06 RESET RUN TIME	NO	NO	NO	NO	NO	
<b>35 MOT TEMP MEAS</b>						
35.01 MOT 1 TEMP AI1 SEL	NOT IN USE	NOT IN USE	NOT IN USE	NOT IN USE	NOT IN USE	
35.02 MOT 1 TEMP ALM L	110	110	110	110	110	
35.03 MOT 1 TEMP FLT L	130	130	130	130	130	
35.04 MOT 2 TEMP AI2 SEL	NOT IN USE	NOT IN USE	NOT IN USE	NOT IN USE	NOT IN USE	
35.05 MOT 2 TEMP ALM L	110	110	110	110	110	
35.06 MOT 2 TEMP FLT L	130	130	130	130	130	
35.07 MOT MOD COMPENSAT	YES	YES	YES	YES	YES	
<b>40 PID CONTROL</b>						
40.01 PID GAIN	1.0	1.0	1.0	1.0	1.0	
40.02 PID INTEG TIME	60.00 s	60.00 s	60.00 s	60.00 s	60.00 s	
40.03 PID DERIV TIME	0.00 s	0.00 s	0.00 s	0.00 s	0.00 s	
40.04 PID DERIV FILTER	1.00 s	1.00 s	1.00 s	1.00 s	1.00 s	
40.05 ERROR VALUE INV	NO	NO	NO	NO	NO	
40.06 ACTUAL VALUE SEL	ACT1	ACT1	ACT1	ACT1	ACT1	
40.07 ACTUAL1 INPUT SEL	AI2	AI2	AI2	AI2	AI2	
40.08 ACTUAL2 INPUT SEL	AI2	AI2	AI2	AI2	AI2	
40.09 ACT1 MINIMUM	0 %	0 %	0 %	0 %	0 %	
40.10 ACT1 MAXIMUM	100 %	100 %	100 %	100 %	100 %	
40.11 ACT2 MINIMUM	0 %	0 %	0 %	0 %	0 %	
40.12 ACT2 MAXIMUM	100 %	100 %	100 %	100 %	100 %	
40.13 PID INTEGRATION	ON	ON	ON	ON	ON	
40.14 TRIM MODE	OFF	OFF		OFF	OFF	
40.15 TRIM REF SEL	AI1	AI1		AI1	AI1	
40.16 TRIM REFERENCE	0.0%	0.0%		0.0%	0.0%	
40.17 TRIM RANGE ADJUST	0.0%	0.0%		0.0%	0.0%	
40.18 TRIM SELECTION				SPEED TRIM		
40.19 ACTUAL FILT TIME	0.04 s	0.04 s	0.04 s	0.04 s	0.04 s	
40.20 SLEEP SELECTION			OFF			
40.21 SLEEP LEVEL			0.0 rpm			
40.22 SLEEP DELAY			0.0 s			
40.23 WAKE UP LEVEL			0.0 %			
40.24 WAKE UP DELAY			0.0 s			
<b>42 BRAKE CONTROL</b>						
42.01 BRAKE CTRL	OFF	OFF	OFF	OFF	OFF	
42.02 BRAKE ACKNOWLEDGE	OFF	OFF	OFF	OFF	OFF	
42.03 BRAKE OPEN DELAY	0.0 s	0.0 s	0.0 s	0.0 s	0.0 s	

Appendix B – Default Settings of Application Macros

Parameter	Factory	Hand/Auto	PID Control	Torque Control	Sequential Control	Custom Setting
42.04 BRAKE CLOSE DELAY	0.0 s	0.0 s	0.0 s	0.0 s	0.0 s	
42.05 ABS BRAKE CLS SPD	100 rpm	100 rpm	100 rpm	100 rpm	100 rpm	
42.06 BRAKE FAULT FUNC	FAULT	FAULT	FAULT	FAULT	FAULT	
42.07 START TORQ REF SEL	NO	NO	NO	NO	NO	
42.08 START TORQ REF	0%	0%	0%	0%	0%	
<b>50 ENCODER MODULE</b>						
50.01 PULSE NR	2048	2048	2048	2048	2048	
50.02 SPEED MEAS MODE	A . B .	A . B .	A . B .	A . B .	A . B .	
50.03 ENCODER FAULT	WARNING	WARNING	WARNING	WARNING	WARNING	
50.04 ENCODER DELAY	1000	1000	1000	1000	1000	
50.05 ENCODER CHANNEL	CHANNEL 2	CHANNEL 2	CHANNEL 2	CHANNEL 2	CHANNEL 2	
50.06 SPEED FB SEL	INTERNAL	INTERNAL	INTERNAL	INTERNAL	INTERNAL	
<b>51 COMMUNICATION MODULE</b>						
<b>52 STANDARD MODBUS</b>						
52.01 STATION NUMBER	1	1	1	1	1	
52.02 BAUDRATE	9600	9600	9600	9600	9600	
52.03 PARITY	ODD	ODD	ODD	ODD	ODD	
<b>60 MASTER/FOLLOWER</b>						
60.01 MASTER LINK MODE	NOT IN USE	NOT IN USE	NOT IN USE	NOT IN USE	NOT IN USE	
60.02 TORQUE SELECTOR	not visible	not visible	not visible	TORQUE	not visible	
60.03 WINDOW SEL ON	not visible	not visible	not visible	NO	not visible	
60.04 WINDOW WIDTH POS	not visible	not visible	not visible	0	not visible	
60.05 WINDOW WIDTH NEG	not visible	not visible	not visible	0	not visible	
60.06 DROOP RATE	0 to 100%	0%	0%	0%	0%	
60.07 MASTER SIGNAL 2	0000 to 9999	202	202	202	202	
60.08 MASTER SIGNAL 3	0000 to 9999	213	213	213	213	
<b>70 DDCS CONTROL</b>						
70.01 CHANNEL 0 ADDR	1	1	1	1	1	
70.02 CHANNEL 3 ADDR	1	1	1	1	1	
70.03 CH1 BAUDRATE	2 Mbits	2 Mbits	2 Mbits	2 Mbits	2 Mbits	
<b>90 D SET REC ADDR</b>						
90.01 AUX DS REF3	0	0	0	0	0	
90.02 AUX DS REF4	0	0	0	0	0	
90.03 AUX DS REF5	0	0	0	0	0	
90.04 MAIN DS SOURCE	1	1	1	1	1	
90.05 AUX DS SOURCE	3	3	3	3	3	
<b>92 D SET TR ADDR</b>						
92.01 MAIN STATUS WORD	302	302	302	302	302	FIXED
92.02 MAIN DS ACT1	102	102	102	102	102	
92.03 MAIN DS ACT2	105	105	105	105	105	

Appendix B – Default Settings of Application Macros

Parameter	Factory	Hand/Auto	PID Control	Torque Control	Sequential Control	Custom Setting
92.04 AUX DS ACT3	305	305	305	305	305	
92.05 AUX DS ACT4	308	308	308	308	308	
92.06 AUX DS ACT5	306	306	306	306	306	
<b>96 EXTERNAL AO</b>						
96.01 EXT AO1	SPEED	SPEED	SPEED	SPEED	SPEED	
96.02 INVERT EXT AO1	NO	NO	NO	NO	NO	
96.03 MINIMUM EXT AO1	0 mA	0 mA	0 mA	0 mA	0 mA	
96.04 FILTER EXT AO1	0.01 s	0.01 s	0.01 s	0.01 s	0.01 s	
96.05 SCALE EXT AO1	100 %	100 %	100 %	100 %	100 %	
96.06 EXT AO2	CURRENT	CURRENT	CURRENT	CURRENT	CURRENT	
96.07 INVERT EXT AO2	NO	NO	NO	NO	NO	
96.08 MINIMUM EXT AO2	0 mA	0 mA	0 mA	0 mA	0 mA	
96.09 FILTER EXT AO2	2.00 s	2.00 s	2.00 s	2.00 s	2.00 s	
96.10 SCALE EXT AO2	100 %	100 %	100 %	100 %	100 %	
<b>98 OPTION MODULES</b>						
98.01 ENCODER MODULE	NO	NO	NO	NO	NO	
98.02 COMM. MODULE LINK	NO	NO	NO	NO	NO	
98.03 DI/O EXT MODULE 1	NO	NO	NO	NO	NO	
98.04 DI/O EXT MODULE 2	NO	NO	NO	NO	NO	
98.05 DI/O EXT MODULE 3	NO	NO	NO	NO	NO	
98.06 AI/O EXT MODULE	NO	NO	NO	NO	NO	
98.07 COMM PROFILE	ABB DRIVES	ABB DRIVES	ABB DRIVES	ABB DRIVES	ABB DRIVES	
98.08 NIOC-01 BOARD	YES	YES	YES	YES	YES	
98.09 NDIO1 DI FUNC	DI7,8	DI7,8	DI7,8	DI7,8	DI7,8	
98.10 NDIO2 DI FUNC	DI9,10	DI9,10	DI9,10	DI9,10	DI9,10	
98.11 NDIO3 DI FUNC	DI11,12	DI11,12	DI11,12	DI11,12	DI11,12	
98.12 AI/O MOTOR TEMP	NO	NO	NO	NO	NO	

1) Parameter 30.05 MOTOR THERM P MODE: For units ACx 607-0400-3, -0490-3 -0490-6 and above, the default setting is USER MODE.



# Appendix C – Fieldbus Control

## Overview

The ACS 600 can be connected to an external control system – usually a fieldbus – via an adapter module (connected to fibre optic channel CH0 on the NDCO board) and/or a Modbus-protocol RS-485 connection (on the NIOC-01 board).

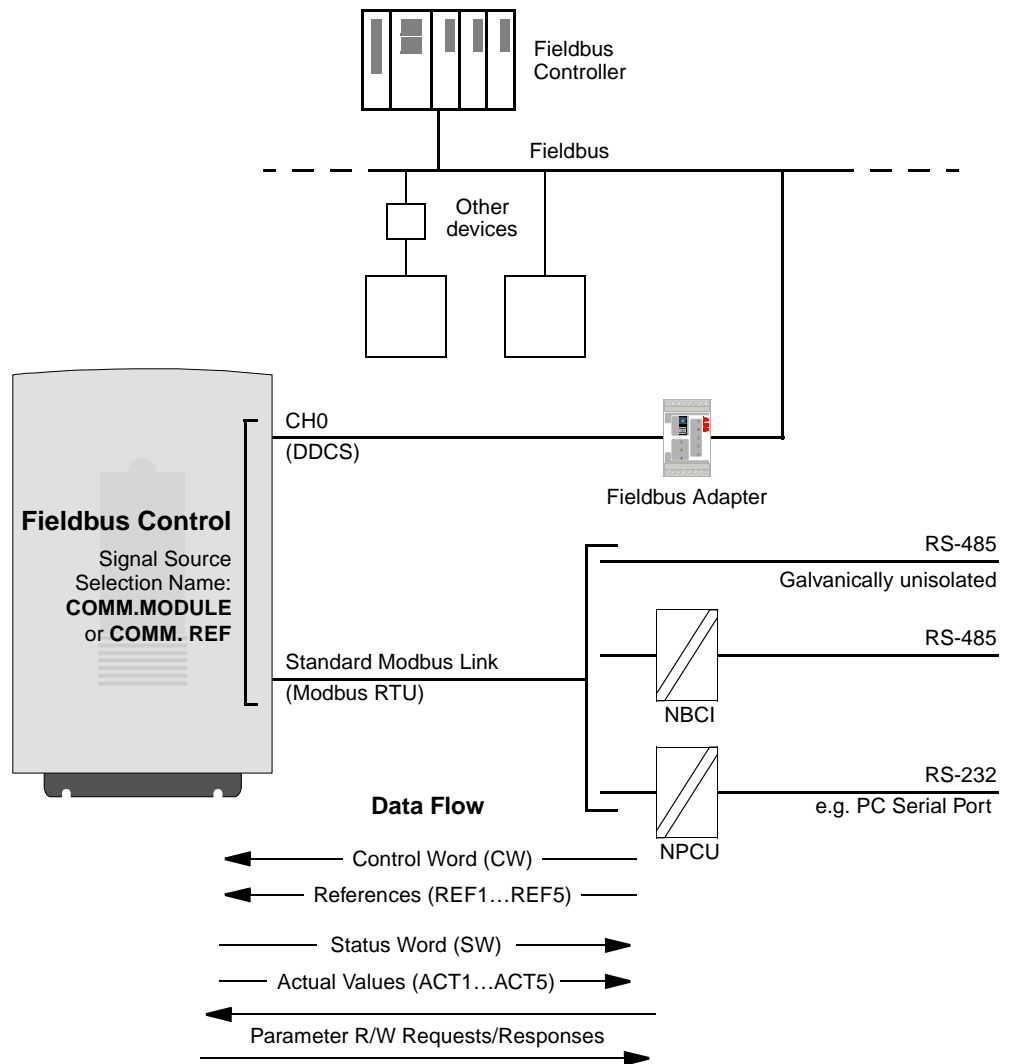

Figure C-1 Fieldbus control.

The drive can be set to receive all of its control information from one fieldbus channel, or the control can be distributed between the two fieldbus channels and other available sources, e.g. digital and analogue inputs.

**Control via NDCO Board Channel CH0**

The DDCS-protocol fibre optic channel CH0, located on the NDCO add-on communication board, is used for connecting the ACS 600 to a fieldbus adapter module. (The NDCO board may be ordered factory-installed or as an add-on kit. It is also installed at the factory if required by another option.)

Channel CH0 is also used for connecting the ACS 600 to an Advant control system. From the drive’s point of view, Advant connection is similar to a fieldbus adapter connection.

**Fieldbus Adapter Communication Set-up**

Before configuring the ACS 600 for fieldbus control, the adapter module must be mechanically and electrically installed according to the instructions given in the *Hardware Manual* of the drive and the module manual.

The communication between the ACS 600 and the fieldbus adapter module is then activated by setting Parameter 98.02 COMM. MODULE LINK. After the communication is initialised, the configuration parameters of the module become available in the drive at Parameter Group 51. These parameters are specific to the module used; see its manual for information on the available settings.

Table C-1 Communication set-up parameters for channel CH0 (for Fieldbus Adapter connection).

Parameter	Alternative Settings	Setting for Control through CH0	Function/Information
<i>COMMUNICATION INITIALISATION</i>			
98.02 COMM. MODULE LINK	NO; FIELDBUS; ADVANT; STD MODBUS; CUSTOMISED	FIELDBUS	Initialises communication between drive (fibre optic channel CH0) and fieldbus adapter module. Activates module parameters (Group 51).
98.07 COMM PROFILE	ABB DRIVES; CSA 2.8/3.0	ABB DRIVES	Selects the communication profile used by the drive. Affects both fieldbus channels (fibre optic channel CH0 and Standard Modbus Link). See section <i>Communication Profiles</i> later in this Appendix.
<i>ADAPTER MODULE CONFIGURATION (Module-specific; see module manual.)</i>			
51.01 (FIELDBUS PARAMETER 1)		–	
...	...	...	...
51.15 (FIELDBUS PARAMETER 15)		–	

After the parameters in Group 51 have been set, the drive control parameters (shown in [Table C-4](#)) must be checked and adjusted where necessary.

**AF 100 Connection** The connection of an ACS 600 to an AF (Advant Fieldbus) 100 bus is similar to other fieldbusses, with the exception that one of the AF 100 interfaces listed below is substituted for the fieldbus adapter. As opposed to other fieldbusses, Parameter Group 51 contains no adjustable parameters. The drive (channel CH0) is connected to the AF 100 interface using fibre optic cables. The following is a list of suitable interfaces:

- **CI810A Fieldbus Communication Interface (FCI)**  
*TB811 (5 MBd) or TB810 (10 MBd) Optical ModuleBus Port Interface required*
- **Advant Controller 70 (AC 70)**  
*TB811 (5 MBd) or TB810 (10 MBd) Optical ModuleBus Port Interface required*
- **Advant Controller 80 (AC 80)**  
*Optical ModuleBus connection: TB811 (5 MBd) or TB810 (10 MBd) Optical ModuleBus Port Interface required*  
*DriveBus connection: Connectible to NAMC-11 Board with NDCO-01 Communication Option.*

One of the above interfaces may already be present on the AF 100 bus. If not, an Advant Fieldbus 100 Adapter kit (NAFA-01) is separately available, containing the CI810A Fieldbus Communication Interface, TB810 and TB811 Optical ModuleBus Port Interfaces, and a TC505 Trunk Tap. (More information on these components is available from the *S800 I/O User's Guide*, 3BSE 008 878 [ABB Industrial Systems, Västerås, Sweden]).

**Optical Component Types** The TB811 Optical ModuleBus Port Interface is equipped with 5 MBd optical components, while the TB810 has 10 MBd components. All optical components on a fibre optic link must be of the same type since 5 MBd components do not communicate with 10 MBd components. The choice between TB810 and TB811 depends on the equipment it is connected to.

The TB811 (5 MBd) should be used when connecting to a drive with the following equipment:

- NAMC-03 Board (not used with Std. Application Program 5.2 or later versions)
- NAMC-11/51 Board with NDCO-02 Communication Option
- NAMC-11/51 Board with NDCO-03 Communication Option
- NAMC-22 Board.

The TB810 (10 MBd) should be used when connecting to the following equipment:

- NAMC-11/51 Board with NDCO-01 Communication Option
- NAMC-21 Board
- NDBU-85/95 DDCS Branching Units.

**Communication Set-up** The communication between the ACS 600 and the AF 100 interface is activated by setting Parameter 98.02 COMM. MODULE LINK to ADVANT.

Table C-2 Communication set-up parameters for channel CH0 (For AF 100 connection).

Parameter	Alternative Settings	Setting for Control through CH0	Function/Information
<i>COMMUNICATION INITIALISATION</i>			
98.02 COMM. MODULE LINK	NO; FIELDBUS; ADVANT; STD MODBUS, CUSTOMISED	ADVANT	Initialises communication between drive (fibre optic channel CH0) and AF 100 interface. The transmission speed is 4 Mbit/s.
98.07 COMM PROFILE	ABB DRIVES; CSA 2.8/3.0	ABB DRIVES	Selects the communication profile used by the drive. Affects both fieldbus channels (fibre optic channel CH0 and Standard Modbus Link). See section <i>Communication Profiles</i> later in this Appendix.

After the communication activation parameters have been set, the AF 100 interface must be programmed according to its documentation, and the drive control parameters (shown in Table C-4) checked and adjusted where necessary.

**In an Optical ModuleBus connection**, the value for drive Parameter 70.01 CH0 NODE ADDRESS is calculated from the value of the POSITION terminal in the appropriate database element (for the AC 80, DRISTD) as follows:

1. Multiply the hundreds of the value of POSITION by 16.
2. Add the tens and ones of the value of POSITION to the result.

For example, if the POSITION terminal of the DRISTD database element has the value of 110 (the tenth drive on the Optical ModuleBus ring), Parameter 70.01 must be set to  $16 \times 1 + 10 = 26$ .

**In an AC 80 DriveBus connection**, the drives are addressed 1 to 12. The drive address (set with Parameter 70.01) is related to the value of the DRNR terminal of the ACSRX PC element.

### Control through the Standard Modbus Link

The modular jacks (X28 and X29) on the ACS 600 NIOC-01 board form the Standard Modbus Link. The Link can be used for external control by a Modbus RTU-protocol controller. The controller can be connected either directly or using an NBCI Panel Bus Connection Interface module to obtain galvanic isolation and parallel or long-distance connection of several drives.

An RS-232 port (e.g. a serial port of a PC) can be connected to the Standard Modbus Link through an NPCU-01 PC Connection Unit, which provides galvanic isolation and RS-232/RS-485 conversion. (However, the DriveWindow Light PC tool can only be connected to the Control Panel connector on the NAMC board.)

### Communication Set-up

The communication through the Standard Modbus Link is initialised by setting Parameter 98.02 COMM. MODULE LINK to STD MODBUS. Then, the communication parameters in Group 52 must be adjusted. See the following table.

Table C-3 Communication set-up parameters for the Standard Modbus Link.

Parameter	Alternative Settings	Setting for Control through the Standard Modbus Link	Function/Information
<i>COMMUNICATION INITIALISATION</i>			
98.02 COMM. MODULE LINK	NO; FIELDBUS; ADVANT; STD MODBUS; CUSTOMISED	STD MODBUS	Initialises communication between drive (Standard Modbus Link) and Modbus-protocol controller. Activates communication parameters in Group 52.
98.07 COMM PROFILE	ABB DRIVES; CSA 2.8/3.0	ABB DRIVES	Selects the communication profile used by the drive. Affects both fieldbus channels (fibre optic channel CH0 and Standard Modbus Link). See section <i>Communication Profiles</i> later in this Appendix.
<i>COMMUNICATION PARAMETERS</i>			
52.01 STATION NUMBER	1 to 247	–	Specifies the station number of the drive on the Standard Modbus link.
52.02 BAUDRATE	600; 1200; 2400; 4800; 9600	–	Communication speed for the Standard Modbus Link.
52.03 PARITY	ODD; EVEN; NONE1STOPBIT; NONE2STOPBIT	–	Parity setting for the Standard Modbus Link.

After the parameters in Group 52 have been set, the drive control parameters (shown in [Table C-4](#)) should be checked and adjusted where necessary.

**Drive Control Parameters**

After the desired fieldbus channels have been set up, the drive control parameters listed below in [Table C-4](#) below should be checked and adjusted where necessary.

The **Setting for Fieldbus Control** column gives the value to use when either fieldbus channel (CH0 or Standard Modbus Link) is the desired source or destination for that particular signal. The **Function/Information** column gives a description of the parameter.

The fieldbus signal routes and message composition are explained later in this Appendix under **The Fieldbus Control Interface**. Further information on the alternative parameter settings is also given in Chapter 6.

Table C-4 Drive control parameters to be checked and adjusted for fieldbus control.

Parameter	Setting for Fieldbus Control	Function/Information
<i>CONTROL COMMAND SOURCE SELECTION</i>		
10.01 EXT1 STRT/STP/DIR	COMM.MODULE	Enables the fieldbus Control Word (except bit 11) when EXT1 is selected as control location.
10.02 EXT2 STRT/STP/DIR		Enables the fieldbus Control Word (except bit 11) when EXT2 is selected as control location.
10.03 DIRECTION	REQUEST	Enables rotation direction control as defined by Parameters 10.01 and 10.02.
11.02 EXT1/EXT2 SELECT	COMM.MODULE	Enables EXT1/EXT2 selection by fieldbus Control Word bit 11 EXT CTRL LOC.
11.03 EXT REF1 SELECT	COMM.REF, FAST COMM, COMM.REF+AI1, COMM.REF+AI5, COMM.REF*AI1 or COMM.REF*AI5	Fieldbus reference REF1 is used when EXT1 is selected as control location. See section <i>References</i> below for information on the alternative settings.
11.06 EXT REF2 SELECT		Fieldbus reference REF2 is used when EXT2 is selected as control location. See section <i>References</i> below for information on the alternative settings.
<i>OUTPUT SIGNAL SOURCE SELECTION</i>		
14.01 RELAY RO1 OUTPUT	COMM.MODULE	Enables Relay output RO1 control by fieldbus reference REF3 bit 13.
14.02 RELAY RO2 OUTPUT		Enables Relay output RO2 control by fieldbus reference REF3 bit 14.
14.03 RELAY RO3 OUTPUT		Enables Relay output RO3 control by fieldbus reference REF3 bit 15.
15.01 ANALOGUE OUTPUT1		Directs the contents of fieldbus reference REF4 to Analogue output AO1. <b>Scaling:</b> 20000 = 20 mA
15.06 ANALOGUE OUTPUT2		Directs the contents of fieldbus reference REF5 to Analogue output AO2. <b>Scaling:</b> 20000 = 20 mA.

Parameter	Setting for Fieldbus Control	Function/Information
<i>SYSTEM CONTROL INPUTS</i>		
16.01 RUN ENABLE	COMM.MODULE	Enables the control of the Run Enable signal through fieldbus Control Word bit 3.
16.04 FAULT RESET SEL		Enables fault reset through fieldbus Control Word bit 7.
16.07 PARAM SAVE		Saves parameter value changes (incl. those made through fieldbus control) to permanent memory. See <i>Chapter 6 – Parameters</i> .
<i>COMMUNICATION FAULT FUNCTIONS</i>		
30.18 COMM FAULT FUNC	-	Determines drive action in case fieldbus communication is lost. <b>Note:</b> The communication loss detection is based on monitoring of received Main and Auxiliary data sets (whose sources are selected with Parameters 90.04 and 90.05).
30.19 MAIN REF DS T-OUT		Defines the time between Main Reference data set loss detection and the action selected with Parameter 30.18.
30.20 COMM FLT RO/AO		Determines the position in which Relay outputs RO1 to RO3 and Analogue outputs AO1 and AO2 are left upon Auxiliary Reference data set loss.
30.21 AUX REF DS T-OUT		Defines the time between Auxiliary Reference data set loss detection and the action selected with Parameter 30.18. <b>Note:</b> This supervision function is disabled if Pars. 90.01, 90.02 and 90.03 are set to 0.
<i>FIELDBUS REFERENCE TARGET SELECTION (Not visible when 98.02 is set to NO.)</i>		
90.01 AUX DS REF3	-	Defines the drive parameter into which the value of fieldbus reference REF3 is written. <b>Format:</b> <b>xyy</b> , where <b>xx</b> = Parameter Group (10 to 89), <b>yy</b> = Parameter Index. E.g. <b>3001</b> = Parameter 30.01.
90.02 AUX DS REF4		Defines the drive parameter into which the value of fieldbus reference REF4 is written. <b>Format:</b> see Parameter 90.01.
90.03 AUX DS REF5		Defines the drive parameter into which the value of fieldbus reference REF5 is written. <b>Format:</b> see Parameter 90.01.
90.04 MAIN DS SOURCE	1 or 81	If 98.02 COMM. MODULE LINK is CUSTOMISED this parameter selects the fieldbus channel from which the drive reads the Main Reference data set (comprising the fieldbus Control Word, fieldbus reference REF1, and fieldbus reference REF2).
90.05 AUX DS SRCE	3 or 83	If 98.02 COMM. MODULE LINK is CUSTOMISED this parameter selects the fieldbus channel from which the drive reads the Auxiliary Reference data set (comprising fieldbus references REF3, REF4 and REF5).

Parameter	Setting for Fieldbus Control	Function/Information
<i>ACTUAL SIGNAL SELECTION FOR FIELDBUS</i> (Not visible when 98.02 is set to NO.)		
92.01 MAIN DS STATUS WORD	302 (Fixed)	The Status Word is transmitted to as the first word of the Main Actual Signal data set.
92.02 MAIN DS ACT1	-	Selects the Actual signal or Parameter value to be transmitted as the second word (ACT1) of the Main Actual Signal data set. <b>Format:</b> (x)xyy, where (x)x = Actual Signal Group or Parameter Group, yy = Actual Signal or Parameter Index. E.g. <b>103</b> = Actual Signal 1.03 FREQUENCY; <b>2202</b> = Parameter 22.02 ACCEL TIME 1.
92.03 MAIN DS ACT2		Selects the Actual signal or Parameter value to be transmitted as the third word (ACT2) of the Main Actual Signal data set. <b>Format:</b> see Parameter 92.02.
92.04 AUX DS ACT3		Selects the Actual signal or Parameter value to be transmitted as the first word (ACT3) of the Auxiliary Actual Signal data set. <b>Format:</b> see Parameter 92.02.
92.05 AUX DS ACT4		Selects the Actual signal or Parameter value to be transmitted as the second word (ACT4) of the Auxiliary Actual Signal data set. <b>Format:</b> see Parameter 92.02.
92.06 AUX DS ACT5		Selects the Actual signal or Parameter value to be transmitted as the third word (ACT5) of the Auxiliary Actual Signal data set. <b>Format:</b> see Parameter 92.02.



## **The Fieldbus Control Interface**

The communication between a fieldbus system and the ACS 600 employs *data sets*. One data set consists of three 16-bit words. The ACS 600 Standard Application Program supports the use of four data sets, two in each direction. The ACS 600 has a memory location for two control and two status data sets for each fieldbus channel (the fibre optic channel CH0 and the Standard Modbus Link), totalling 4 input and 4 output memory locations. Two out of the four input data sets are selected with Parameter 98.02 COMM. MODULE LINK, 90.04 MAIN REF DS SOURCE and 90.05 AUX REF DS SOURCE. The selected data sets form the *Main Reference data set* and the *Auxiliary Reference data set* which are used to control the drive.

The status information transmitted by the drive is selected with Parameters 92.01 to 92.03 (the *Main Actual Signal data set*), and the 92.04 to 92.06 (the *Auxiliary Actual Signal data set*).

The update time for the Main Reference and Main Actual Signal data sets is 12 milliseconds; for the Auxiliary Reference and Auxiliary Actual Signals, it is 100 milliseconds.

[Figure C-2](#) and [Figure C-3](#) demonstrate the routes of input and output signals for fieldbus control.

## **The Control Word and the Status Word**

The Control Word (CW) is the principal means for controlling the drive from a fieldbus system. It is effective when the current control location (EXT1 or EXT2, see Parameters 10.01 and 10.02) is set to COMM. MODULE.

The Control Word (detailed in [Table C-5](#)) is sent by the fieldbus controller to the drive. The drive switches between its states (shown in [Figure C-4](#)) according to the bit-coded instructions of the Control Word.

The Status Word (SW) is a word containing status information, sent by the drive to the fieldbus controller. The composition of the Status Word is explained in [Table C-6](#).

## **References**

References (REF) are 16-bit words comprising a sign bit and a 15-bit integer. A negative reference (indicating reversed direction of rotation) is formed by calculating the two's complement from the corresponding positive reference value if the value of Parameter 10.01 EXT1 STRT/STP/DIR or 10.02 EXT2 STRT/STP/DIR is COMM. MODULE.

## **Fieldbus Reference Selection and Correction**

Fieldbus reference (called COMMREF in signal selection contexts) is selected by setting a Reference selection parameter – 11.03 EXT REF1 SELECT or 11.06 EXT REF2 SELECT – to COMM.REF, FAST COMM, COMM.REF+AI1, COMM.REF\*AI1, COMM.REF+AI5, or COMM.REF\*AI5. The latter four selections enable correction of the fieldbus reference using analogue inputs as shown below. (An optional NAIO-03 Analogue I/O Extension Module is required for use of Analogue input AI5).

**COMM.REF**

The fieldbus reference is forwarded as such without correction.

**FAST COMM**

The fieldbus reference is forwarded as such without correction. The reference is read every 2 milliseconds if either of the following conditions is met:

- Control location is **EXT1**, Par. 99.04 MOTOR CTRL MODE is **DTC**, and Par. 40.14 TRIM MODE is **OFF**
- Control location is **EXT2**, Par. 99.04 MOTOR CTRL MODE is **DTC**, Par. 40.14 TRIM MODE is **OFF**, and a **torque reference** is used.

In any other event, the fieldbus reference is read every 6 milliseconds.

**Note:** The FAST COMM selection disables the critical speed function.

**COMM.REF+AI1; COMM.REF+AI5; COMM.REF\*AI1;  
COMM.REF\*AI5**

These selections enable the correction of the fieldbus reference as follows:

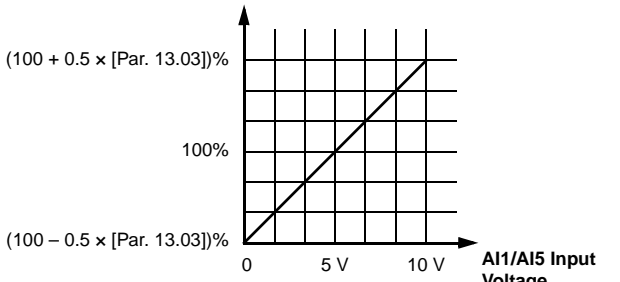
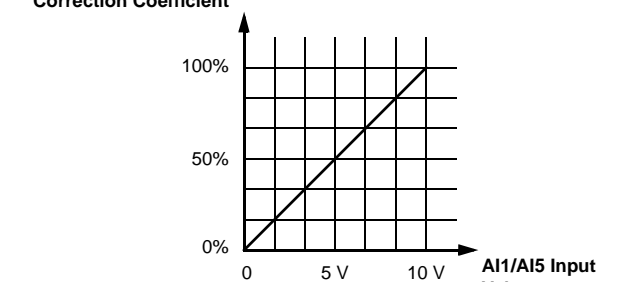
Parameter Setting	Effect of AI1/AI5 Input Voltage on Fieldbus Reference
COMMREF+AI1 COMMREF+AI5	<p style="text-align: center;"><b>Fieldbus Reference Correction Coefficient</b></p> <p style="text-align: center;">(100 + 0.5 × [Par. 13.03])%</p>  <p style="text-align: center;">(100 – 0.5 × [Par. 13.03])%</p> <p style="text-align: right;">AI1/AI5 Input Voltage</p>
COMMREF*AI1 COMMREF*AI5	<p style="text-align: center;"><b>Fieldbus Reference Correction Coefficient</b></p>  <p style="text-align: right;">AI1/AI5 Input Voltage</p>

*Fieldbus Reference Scaling* Corrected (if correction is applied; see above) fieldbus references  
REF1 and REF2 are scaled as shown in the table below.

Ref. No.	Application Macro Used (Par. 99.02)	Reference Type	Range	Scaling	Notes
REF1	(any)	Speed or Frequency	-32765 ... 32765	-20000 = <b>-[Par. 11.05]</b> 0 = 0 20000 = <b>[Par. 11.05]</b>	Not limited by Pars. 11.04/11.05. Final reference limited by 20.01/20.02 [speed] or 20.07/20.08 [frequency].
REF2	FACTORY, HAND/AUTO, or SEQ CTRL	Speed or Frequency	-32765 ... 32765	-20000 = <b>-[Par. 11.08]</b> 0 = 0 20000 = <b>[Par. 11.08]</b>	Not limited by Pars. 11.07/11.08. Final reference limited by 20.01/20.02 [speed] or 20.07/20.08 [frequency].
	T CTRL or M/F (optional)	Torque	-32765 ... 32765	-10000 = <b>-[Par. 11.08]</b> 0 = 0 10000 = <b>[Par. 11.08]</b>	Not limited by Pars. 11.07/11.08. Final reference limited by Par. 20.04.
	PID CTRL	PID Reference	-32765 ... 32765	-10000 = <b>-[Par. 11.08]</b> 0 = 0 10000 = <b>[Par. 11.08]</b>	Not limited by Pars. 11.07/11.08.

**How Direction of Rotation Is Determined in Fieldbus Control**

The control of rotation direction is configured for each control location (EXT1 and EXT2) using the parameters in Group 10. Fieldbus references are bipolar, ie. they can be negative or positive. The following diagrams illustrate how Group 10 parameters and the sign of the fieldbus reference interact.

The diagrams below show the relation between the fieldbus reference and the resultant REF1/REF2 when

- Parameter 10.01/10.02 EXTx STRT/STP/DIR = COMM. MODULE, OR
- Parameter 11.03/11.06 EXT REFx SELECT is set to FAST COMM.

<p>Par. 10.03 DIRECTION = <b>FORWARD</b></p>	
<p>Par. 10.03 DIRECTION = <b>REVERSE</b></p>	
<p>Par. 10.03 DIRECTION = <b>REQUEST</b></p>	
<p>*10000 if Reference Type is Torque or PID</p>	

The following diagrams show the relation between the fieldbus reference and the resultant REF1/REF2 when

- Par. 10.01/10.02 EXT<sub>x</sub> STRT/STP/DIR is not set to COMM.MODULE AND
- Par. 11.03/11.06 EXT REF<sub>x</sub> SELECT is not set to FAST COMM.

	Direction received from source defined by Par. 10.01/10.02 EXT <sub>x</sub> STRT/STP/DIR = <b>FORWARD</b>	Direction received from source defined by Par. 10.01/10.02 EXT <sub>x</sub> STRT/STP/DIR = <b>REVERSE</b>
Par. 10.03 DIRECTION = <b>FORWARD</b>	<p>The graph shows a coordinate system where the vertical axis is 'Resultant REF1/2' and the horizontal axis is 'Fieldbus Ref. 1/2'. The horizontal axis has tick marks at -32767, -20000*, 0, 20000*, and 32767. A vertical dashed line is at 20000*. A horizontal dashed line is at [11.05/11.08]. The resultant is zero for negative fieldbus references and increases linearly for positive fieldbus references. A vertical tick mark on the resultant axis is at [11.05/11.08].</p>	<p>The graph shows a coordinate system where the vertical axis is 'Resultant REF1/2' and the horizontal axis is 'Fieldbus Ref. 1/2'. The horizontal axis has tick marks at -32767, -20000*, 0, 20000*, and 32767. A vertical dashed line is at 20000*. A horizontal dashed line is at [11.05/11.08]. The resultant is zero for positive fieldbus references and decreases linearly for negative fieldbus references. A vertical tick mark on the resultant axis is at [11.05/11.08].</p>
Par. 10.03 DIRECTION = <b>REVERSE</b>	<p>The graph shows a coordinate system where the vertical axis is 'Resultant REF1/2' and the horizontal axis is 'Fieldbus Ref. 1/2'. The horizontal axis has tick marks at -32767, -20000*, 0, 20000*, and 32767. A vertical dashed line is at 20000*. A horizontal dashed line is at [11.05/11.08]. The resultant is zero for positive fieldbus references and decreases linearly for negative fieldbus references. A vertical tick mark on the resultant axis is at [11.05/11.08].</p>	<p>The graph shows a coordinate system where the vertical axis is 'Resultant REF1/2' and the horizontal axis is 'Fieldbus Ref. 1/2'. The horizontal axis has tick marks at -32767, -20000*, 0, 20000*, and 32767. A vertical dashed line is at 20000*. A horizontal dashed line is at [11.05/11.08]. The resultant is zero for negative fieldbus references and increases linearly for positive fieldbus references. A vertical tick mark on the resultant axis is at [11.05/11.08].</p>
Par. 10.03 DIRECTION = <b>REQUEST</b>	<p>The graph shows a coordinate system where the vertical axis is 'Resultant REF1/2' and the horizontal axis is 'Fieldbus Ref. 1/2'. The horizontal axis has tick marks at -32767, -20000*, 0, 20000*, and 32767. A vertical dashed line is at 20000*. A horizontal dashed line is at [11.05/11.08]. The resultant is zero for negative fieldbus references and increases linearly for positive fieldbus references. A vertical tick mark on the resultant axis is at [11.05/11.08].</p>	<p>The graph shows a coordinate system where the vertical axis is 'Resultant REF1/2' and the horizontal axis is 'Fieldbus Ref. 1/2'. The horizontal axis has tick marks at -32767, -20000*, 0, 20000*, and 32767. A vertical dashed line is at 20000*. A horizontal dashed line is at [11.05/11.08]. The resultant is zero for positive fieldbus references and decreases linearly for negative fieldbus references. A vertical tick mark on the resultant axis is at [11.05/11.08].</p>
*10000 if Reference Type is Torque or PID		

**Actual Values** Actual Values (ACT) are 16-bit words containing information on selected operations of the drive. The functions to be monitored are selected with the parameters in Group 92. The scaling of the integers sent to the master as Actual Values depends on the selected function; please refer to the **Scaling for Fieldbus** column in the tables of Appendix A.

The contents of Group 3 Actual Signals are presented in this Appendix from [Table C-7](#) onwards. (The Control and Status Words are also available as Actual Signals 3.01 and 3.02 respectively.)

**Modbus Addressing** In the Modbus controller memory, the Control Word, the Status Word, the references, and the actual values are mapped as follows:

Address	Contents	Address	Contents
40001	Control Word	40004	Status Word
40002	REF1	40005	ACT1
40003	REF2	40006	ACT2
40007	REF3	40010	ACT3
40008	REF4	40011	ACT4
40009	REF5	40012	ACT5

More information on Modbus communication is available from the separate publication *NMBA-01 Installation and Start-up Guide* (3AFY 58919772 [English]; available from ABB Industry Oy, Helsinki, Finland) and the Modicon website <http://www.modicon.com>.

Figure C-2 Control data input from fieldbus.

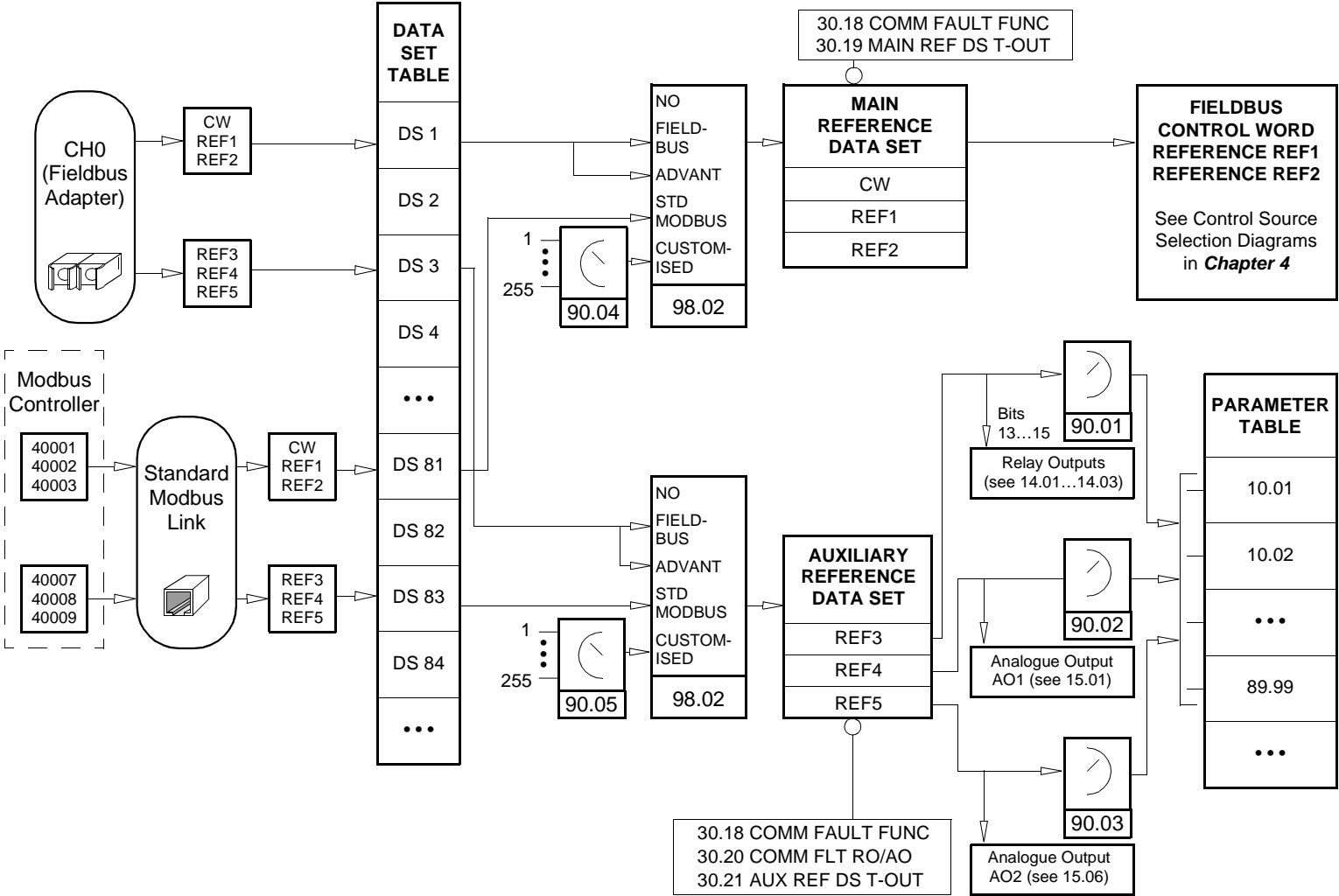

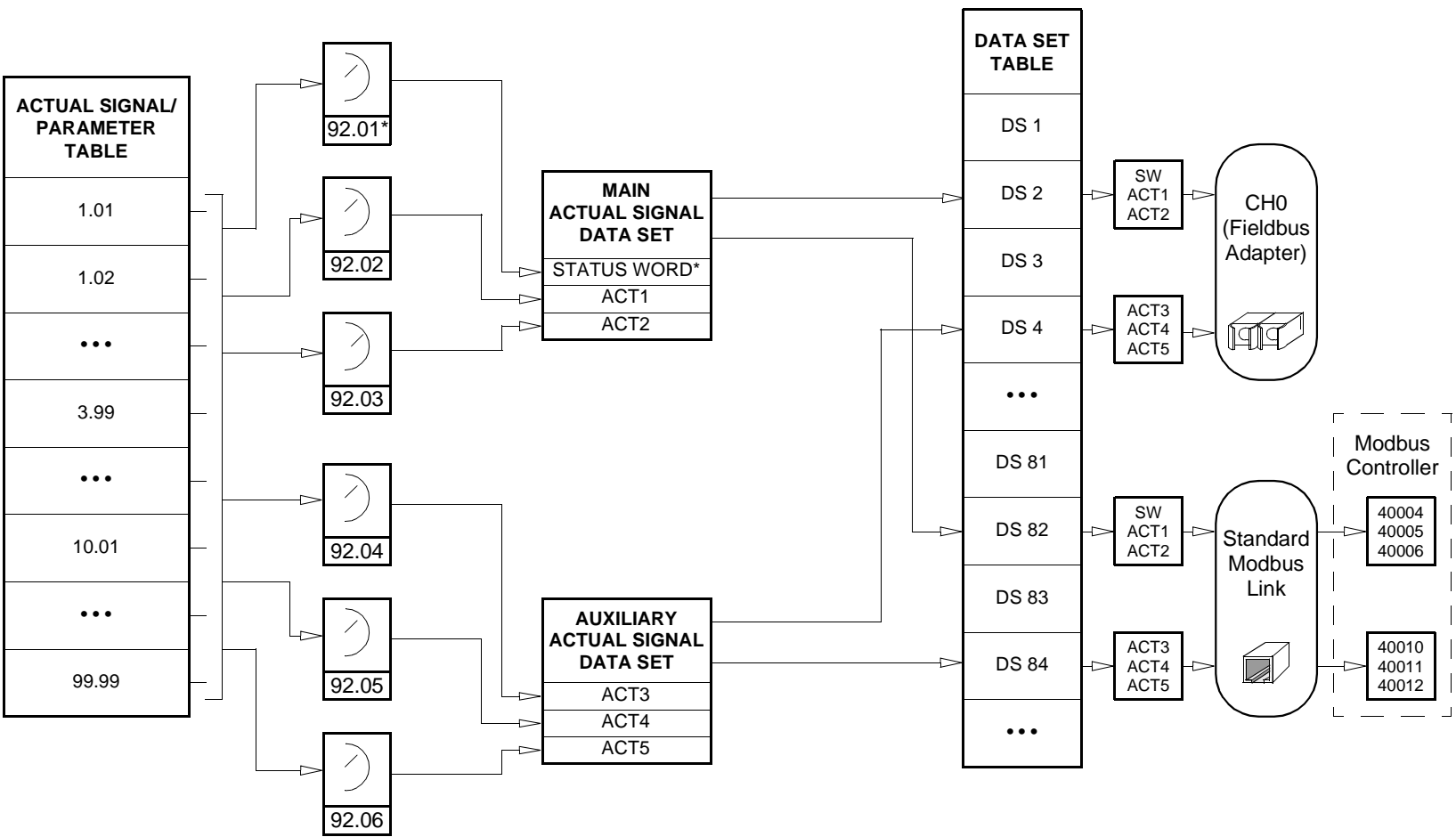

\*Par. 92.01 is fixed to 3.02 MAIN STATUS WORD.

Figure C-3 Actual value selection for fieldbus.



## **Communication Profiles**

Standard Application Program 5.0 (or later) supports the *ABB Drives* communication profile, which standardises the control interface (such as the Control and Status Words) among ABB drives. The ABB Drives profile derives from the PROFIBUS control interface and provides a variety of control and diagnostic functions (see [Table C-5](#), [Table C-6](#) and [Figure C-4](#)).

In order to retain backward compatibility with Standard Application Program versions 2.8 and 3.0, a communication profile suitable for these versions (*CSA 2.8/3.0*) can be selected with Parameter 98.07 COMM INTERFACE. This eliminates the need for reprogramming the PLC when ACS 600 drives with program versions 2.8 or 3.0 are replaced.

The Control and Status Words for the *CSA 2.8/3.0* communication profile are detailed in [Table C-19](#) and [Table C-20](#) respectively.

---

**Note:** The communication profile selector parameter 98.07 COMM PROFILE affects both the optical CH0 and the Standard Modbus channels.

---

Table C-5 The Control Word (Actual Signal 3.01) for the ABB Drives Communication Profile. The upper case boldface text refers to the states shown in Figure C-4.

Bit	Name	Value	Enter STATE/Description
0	ON	1	Enter <b>READY TO OPERATE</b> .
	OFF1	0	Emergency OFF, stop within time defined by Par. 22.07 EM STOP RAMP TIME. Enter <b>OFF1 ACTIVE</b> ; proceed to <b>READY TO SWITCH ON</b> unless other interlocks (OFF2, OFF3) are active.
1	OFF2	1	Continue operation (OFF2 inactive).
		0	Emergency OFF, coast to stop. Enter <b>OFF2 ACTIVE</b> ; proceed to <b>SWITCH-ON INHIBITED</b> .
2	OFF3	1	Continue operation (OFF3 inactive).
		0	Emergency stop, stop within time defined by Par. 22.07 EM STOP RAMP TIME. Enter <b>OFF3 ACTIVE</b> ; proceed to <b>SWITCH-ON INHIBITED</b> . <b>Warning:</b> Ensure motor and driven machine can be stopped using this stop mode.
3	START	1	Enter <b>OPERATION ENABLED</b> . ( <b>Note:</b> The Run enable signal must be active; see Parameter 16.01. If Par. 16.01 is set to COMM. MODULE, this bit also activates the Run enable signal.)
		0	Inhibit operation. Enter <b>OPERATION INHIBITED</b> .
4	RAMP_OUT_ZERO	1	Normal operation. Enter <b>RAMP FUNCTION GENERATOR: OUTPUT ENABLED</b> .
		0	Force Ramp Function Generator output to zero. Drive ramps to stop (current and DC voltage limits in force).
5	RAMP_HOLD	1	Enable ramp function. Enter <b>RAMP FUNCTION GENERATOR: ACCELERATOR ENABLED</b> .
		0	Halt ramping (Ramp Function Generator output held).
6	RAMP_IN_ZERO	1	Normal operation. Enter <b>OPERATING</b> .
		0	Force Ramp Function Generator input to zero.
7	RESET	0 ⇒ 1	Fault reset if an active fault exists. Enter <b>SWITCH-ON INHIBITED</b> .
		0	Continue normal operation.
8	INCHING_1	1	Not in use.
		1 ⇒ 0	Not in use.
9	INCHING_2	1	Not in use.
		1 ⇒ 0	Not in use.
10	REMOTE_CMD	1	Fieldbus control enabled.
		0	Control Word <> 0 or Reference <> 0: Retain last Control Word and Reference. Control Word = 0 and Reference = 0: Fieldbus control enabled. Reference and deceleration/acceleration ramp are locked.
11	EXT CTRL LOC	1	Select External Control Location 2 (EXT2). Effective if Par. 11.02 is set to COMM.MODULE.
		0	Select External Control Location 1 (EXT1). Effective if Par. 11.02 is set to COMM.MODULE.
12 to 15	Reserved		

Table C-6 The Status Word (Actual Signal 3.02) for the ABB Drives Communication Profile. The upper case boldface text refers to the states shown in Figure C-4.

Bit	Name	Value	STATE/Description
0	RDY_ON	1	<b>READY TO SWITCH ON.</b>
		0	<b>NOT READY TO SWITCH ON.</b>
1	RDY_RUN	1	<b>READY TO OPERATE.</b>
		0	<b>OFF1 ACTIVE.</b>
2	RDY_REF	1	<b>OPERATION ENABLED.</b>
		0	<b>OPERATION INHIBITED.</b>
3	TRIPPED	1	<b>FAULT.</b>
		0	No fault.
4	OFF_2_STA	1	OFF2 inactive.
		0	<b>OFF2 ACTIVE.</b>
5	OFF_3_STA	1	OFF3 inactive.
		0	<b>OFF3 ACTIVE.</b>
6	SWC_ON_INHIB	1	<b>SWITCH-ON INHIBITED.</b>
		0	
7	ALARM	1	Warning/Alarm.
		0	No Warning/Alarm.
8	AT_SETPOINT	1	<b>OPERATING.</b> Actual value equals reference value (= is within tolerance limits).
		0	Actual value differs from reference value (= is outside tolerance limits).
9	REMOTE	1	Drive control location: REMOTE (EXT1 or EXT2).
		0	Drive control location: LOCAL.
10	ABOVE_LIMIT	1	Actual frequency or speed value equals or is greater than supervision limit (Par. 32.02). Valid in both rotation directions regardless of value of Par. 32.02.
		0	Actual frequency or speed value is within supervision limit.
11	EXT CTRL LOC	1	External Control Location 2 (EXT2) selected.
		0	External Control Location 1 (EXT1) selected.
12	EXT RUN ENABLE	1	External Run Enable signal received.
		0	No External Run Enable received.
13 to 14	Reserved		
15		1	Communication error detected by fieldbus adapter module (on fibre optic channel CH0).
		0	Fieldbus adapter (CH0) communication OK.

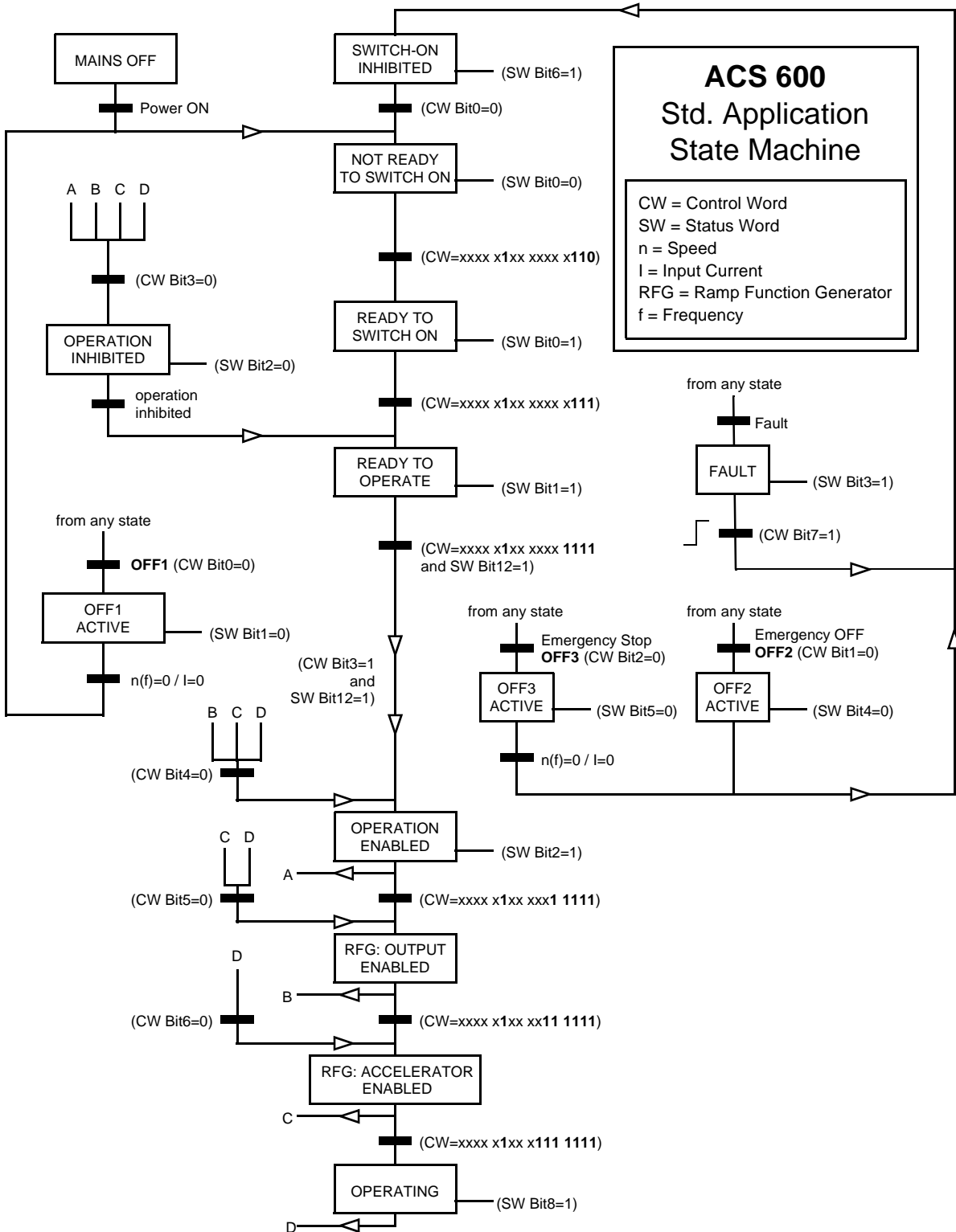

Figure C-4 The ACS 600 State Machine for the Standard Application Program (ABB Drives Communication Profile), effective under fieldbus control.

Table C-7 The Auxiliary Status Word (Actual Signal 3.03).

Bit	Name	Description
0	Reserved	
1	OUT OF WINDOW	Speed difference is out of the window (in speed control)*.
2	Reserved	
3	MAGNETIZED	Flux has been formed in the motor.
4	Reserved	
5	SYNC RDY	Position counter synchronised.
6	1 START NOT DONE	Drive has not been started after changing the motor parameters in Group 99.
7	IDENTIF RUN DONE	Motor ID Run successfully completed.
8	START INHIBITION	Prevention of unexpected start-up active.
9	LIMITING	Control at a limit. See Actual Signal 3.04 LIMIT WORD 1 below.
10	TORQ CONTROL	Torque reference is followed*.
11	ZERO SPEED	Absolute value of motor actual speed is below zero speed limit (4% of synchronous speed).
12	INTERNAL SPEED FB	Internal speed feedback followed.
13	M/F COMM ERR	Master/Follower link (on CH2) communication error*.
14	Reserved	
15	Reserved	

\*See *Master/Follower Application Guide* (3AFY 58962180 [English]).

Table C-8 Limit Word 1 (Actual Signal 3.04).

Bit	Name	Active Limit
0	TORQ MOTOR LIM	Pull-out limit.
1	SPD_TOR_MIN_LIM	Speed control torque min. limit.
2	SPD_TOR_MAX_LIM	Speed control torque max. limit.
3	TORQ_USER_CUR_LIM	User-defined current limit.
4	TORQ_INV_CUR_LIM	Internal current limit.
5	TORQ_MIN_LIM	Any torque min. limit.
6	TORQ_MAX_LIM	Any torque max. limit.
7	TREF_TORQ_MIN_LIM	Torque reference min. limit.
8	TREF_TORQ_MAX_LIM	Torque reference max. limit.
9	FLUX_MIN_LIM	Flux reference min. limit.
10	FREQ_MIN_LIMIT	Speed/Frequency min. limit.
11	FREQ_MAX_LIMIT	Speed/Frequency max. limit.
12	DC_UNDERVOLT	DC undervoltage limit.
13	DC_OVERVOLT	DC overvoltage limit.
14	TORQUE LIMIT	Any torque limit.
15	FREQ_LIMIT	Any speed/frequency limit.

Table C-9 Fault Word 1 (Actual Signal 3.05).

Bit	Name	Description
0	SHORT CIRC	For the possible causes and remedies, see Chapter 7 – Fault Tracing.
1	OVERCURRENT	
2	DC OVERVOLT	
3	ACx 600 TEMP	
4	EARTH FAULT	
5	THERMISTOR	
6	MOTOR TEMP	
7	SYSTEM_FAULT	A fault is indicated by the System Fault Word (Actual Signal 3.07).
8	UNDERLOAD	For the possible causes and remedies, see Chapter 7 – Fault Tracing.
9	OVERFREQ	
10	Reserved	
11	Reserved	
12	Reserved	
13	Reserved	
14	Reserved	
15	Reserved	

Table C-10 Fault Word 2 (Actual Signal 3.06).

Bit	Name	Description
0	SUPPLY PHASE	For the possible causes and remedies, see Chapter 7 – Fault Tracing.
1	NO MOT DATA	
2	DC UNDERVOLT	
3	Reserved	
4	RUN DISABLED	For the possible causes and remedies, see Chapter 7 – Fault Tracing.
5	ENCODER FLT	
6	I/O COMM	
7	AMBIENT TEMP	
8	EXTERNAL FLT	
9	OVER SWFREQ	Switching overfrequency fault.
10	AI < MIN FUNC	For the possible causes and remedies, see Chapter 7 – Fault Tracing.
11	PPCC LINK	
12	COMM MODULE	
13	PANEL LOSS	
14	MOTOR STALL	
15	MOTOR PHASE	

Table C-11 The System Fault Word (Actual Signal 3.07).

Bit	Name	Description
0	FLT (F1_7)	Factory default parameter file error.
1	USER MACRO	User Macro file error.
2	FLT (F1_4)	FEPROM operating error.
3	FLT (F1_5)	FEPROM data error.
4	FLT (F2_12)	Internal time level 2 overflow.
5	FLT (F2_13)	Internal time level 3 overflow.
6	FLT (F2_14)	Internal time level 4 overflow.
7	FLT (F2_15)	Internal time level 5 overflow.
8	FLT (F2_16)	State machine overflow.
9	FLT (F2_17)	Application program execution error.
10	FLT (F2_18)	Application program execution error.
11	FLT (F2_19)	Illegal instruction.
12	FLT (F2_3)	Register stack overflow.
13	FLT (F2_1)	System stack overflow.
14	FLT (F2_0)	System stack underflow.
15	Reserved	

Table C-12 Alarm Word 1 (Actual Signal 3.08).

Bit	Name	Description
0	START INHIBIT	For the possible causes and remedies, see <i>Chapter 7 – Fault Tracing</i> .
1	Reserved	
2	Reserved	
3	MOTOR TEMP	For the possible causes and remedies, see <i>Chapter 7 – Fault Tracing</i> .
4	ACx 600 TEMP	
5	ENCODER ERR	
6	T MEAS ALM	
7	Reserved	
8	Reserved	
9	Reserved	
10	Reserved	
11	Reserved	
12	COMM MODULE	For the possible causes and remedies, see <i>Chapter 7 – Fault Tracing</i> .
13	THERMISTOR	
14	EARTH FAULT	
15	Reserved	

Table C-13 Alarm Word 2 (Actual Signal 3.09).

Bit	Name	Description
0	Reserved	
1	UNDERLOAD	For the possible causes and remedies, see <i>Chapter 7 – Fault Tracing</i> .
2	Reserved	
3	DC UNDERVOLT	For the possible causes and remedies, see <i>Chapter 7 – Fault Tracing</i> .
4	DC OVERVOLT	
5	OVERCURRENT	
6	OVERFREQ	
7	ALM (A_16)	Error in restoring POWERFAIL.DDF.
8	ALM (A_17)	Error in restoring POWERDOWN.DDF.
9	MOTOR STALL	For the possible causes and remedies, see <i>Chapter 7 – Fault Tracing</i> .
10	AI < MIN FUNC	
11	Reserved	
12	Reserved	
13	PANEL LOSS	For the possible causes and remedies, see <i>Chapter 7 – Fault Tracing</i> .
14	Reserved	
15	Reserved	



Table C-14 The NINT Fault Info Word (Actual Signal 3.12). The Word includes information on the location of faults PPCC LINK, OVERCURRENT, EARTH FAULT and SHORT CIRCUIT (see Table C-9 Fault Word 1, Table C-10 Fault Word 2, and Chapter 7 – Fault Tracing).

Bit	Name	Description
0	NINT 1 FLT	NINT 1 board fault*
1	NINT 2 FLT	NINT 2 board fault *
2	NINT 3 FLT	NINT 3 board fault *
3	NINT 4 FLT	NINT 4 board fault *
4	NPBU FLT	NPBU board fault *
5	-	Not in use
6	U-PH SC U	Phase U upper-leg IGBT(s) short circuit
7	U-PH SC L	Phase U lower-leg IGBT(s) short circuit
8	V-PH SC U	Phase V upper-leg IGBT(s) short circuit
9	V-PH SC L	Phase V lower-leg IGBT(s) short circuit
10	W-PH SC U	Phase W upper-leg IGBT(s) short circuit
11	W-PH SC L	Phase W lower-leg IGBT(s) short circuit
12 ... 15		Not in use

\* In use only with parallel inverters. NINT 0 is connected to NPBU CH1, NINT 1 to CH2 etc.

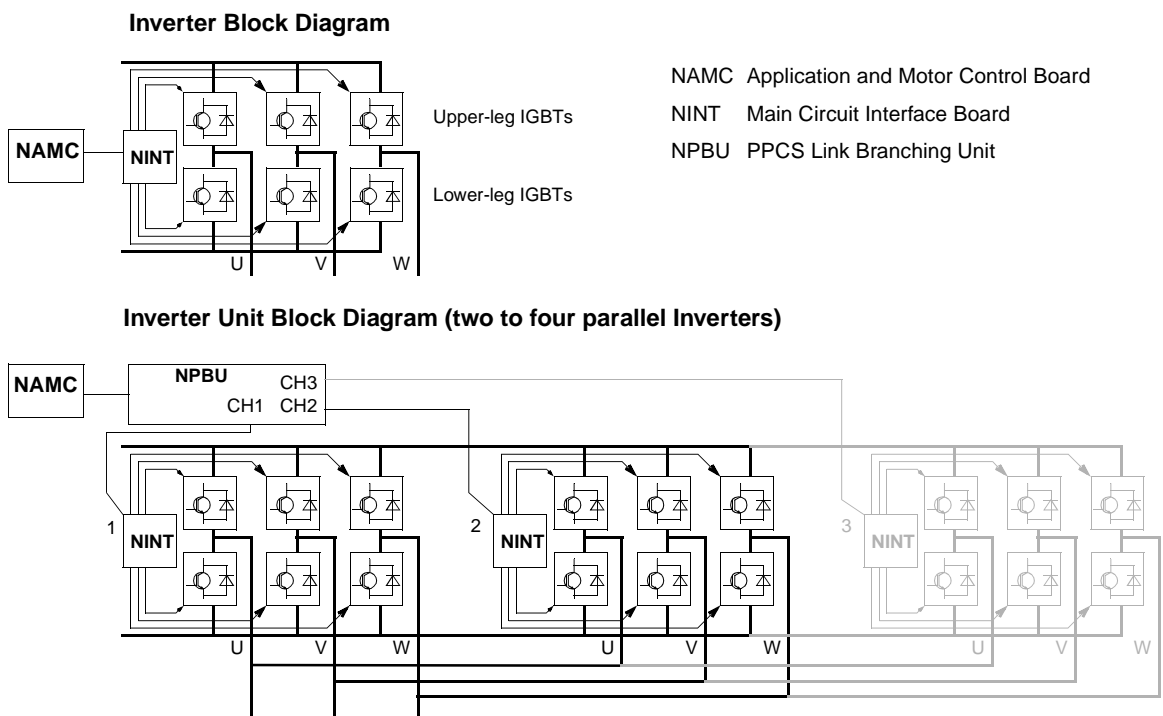

Table C-15 Auxiliary Status Word 3 (Actual Signal 3.13)

Bit	Name	Description
0	REVERSED	Motor rotates in reverse direction.
1	EXT CTRL	External control is selected.
2	REF 2 SEL	Reference 2 is selected.
3	CONST SPEED	A Constant Speed (1...15) is selected.
4	STARTED	The ACS 600 has received a Start command.
5	USER 2 SEL	User Macro 2 has been loaded.
6	OPEN BRAKE	The Open Brake command is ON. See Group 42 BRAKE CONTROL.
7	LOSS OF REF	The reference has been lost.
8	Reserved	
9	Reserved	
10	Reserved	
11	Reserved	
12	Reserved	
13	Reserved	
14	Reserved	
15	Reserved	

Table C-16 Auxiliary Status Word 4 (Actual Signal 3.14)

Bit	Name	Description
0	SPEED 1 LIM	Output speed has exceeded or fallen below supervision limit 1. See Group 32 SUPERVISION.
1	SPEED 2 LIM	Output speed has exceeded or fallen below supervision limit 2. See Group 32 SUPERVISION.
2	CURRENT LIM	Motor current has exceeded or fallen below set supervision limit. See Group 32 SUPERVISION.
3	REF 1 LIM	Reference 1 has exceeded or fallen below the set supervision limit. See Group 32 SUPERVISION.
4	REF 2 LIM	Reference 2 has exceeded or fallen below the set supervision limit. See Group 32 SUPERVISION.
5	TORQUE 1 LIM	The motor torque has exceeded or fallen below the TORQUE1 supervision limit. See Group 32 SUPERVISION.
6	TORQUE 2 LIM	The motor torque has exceeded or fallen below the TORQUE2 supervision limit. See Group 32 SUPERVISION.
7	ACT 1 LIM	PID controller actual value 1 has exceeded or fallen below the set supervision limit. See Group 32 SUPERVISION.
8	ACT 2 LIM	PID controller actual value 2 has exceeded or fallen below the set supervision limit. See Group 32 SUPERVISION.
9	Reserved	
10	Reserved	
11	Reserved	
12	Reserved	
13	Reserved	
14	Reserved	
15	Reserved	

Table C-17 Fault Word 4 (Actual Signal 3.15)

Bit	Name	Description
0	Reserved	
1	MOTOR 1 TEMP	For the possible causes and remedies, see <i>Chapter 7 – Fault Tracing.</i>
2	MOTOR 2 TEMP	
3	BRAKE ACKN	
4	Reserved	
5	Reserved	
6	Reserved	
7	Reserved	
8	Reserved	
9	Reserved	
10	Reserved	
11	Reserved	
12	Reserved	
13	Reserved	
14	Reserved	
15	Reserved	

Table C-18 Alarm Word 4 (Actual Signal 3.16)

Bit	Name	Description
0	Reserved	
1	MOTOR 1 TEMP	For the possible causes and remedies, see <i>Chapter 7 – Fault Tracing.</i>
2	MOTOR 2 TEMP	
3	BRAKE ACKN	
4	SLEEP MODE	
5	Reserved	
6	Reserved	
7	Reserved	
8	Reserved	
9	Reserved	
10	Reserved	
11	Reserved	
12	Reserved	
13	Reserved	
14	Reserved	
15	Reserved	

Table C-19 Control Word for the CSA 2.8/3.0 Communication Profile.

Bit	Name	Description
0	Reserved	
1	ENABLE	1 = Enabled 0 = Coast to stop
2	Reserved	
3	START/STOP	0→1 = Start 0 = Stop according to Parameter 21.03 STOP FUNCTION.
4	Reserved	
5	CNTRL_MODE	1 = Select control mode 2 0 = Select control mode 1
6	Reserved	
7	Reserved	
8	RESET_FAULT	0→1 = Reset drive fault
9...15	Reserved	

Table C-20 Status Word for the CSA 2.8/3.0 Communication Profile.

Bit	Name	Description
0	READY	1 = Ready to start 0 = Initialising, or initialisation error
1	ENABLE	1 = Enabled 0 = Coast to stop
2	Reserved	
3	RUNNING	1 = Running with selected reference 0 = Stopped
4	Reserved	
5	REMOTE	1 = Drive in Remote Mode 0 = Drive in Local Mode
6	Reserved	
7	AT_SETPOINT	1 = Drive at reference 0 = Drive not at reference
8	FAULTED	1 = A fault is active 0 = No active faults
9	WARNING	1 = A warning is active 0 = No active warnings
10	LIMIT	1 = Drive at a limit 0 = Drive at no limit
11...15	Reserved	

# Appendix D – Analogue Extension Module NAIO

---

## **Speed Control Through NAIO**

This section describes the use of the Analogue Extension Module NAIO in speed control of the ACS 600 equipped with the Standard Application Program 6.0.

Two variants are described:

- Bipolar Input in Basic Speed Control
- Bipolar Input in Joystick Mode

Only the use of a bipolar input ( $\pm$  signal range) is covered here. The use of an unipolar input corresponds to that of a standard input when:

- the settings described in sections *Basic Checks* and *NAIO Settings* are done (see below), and
- the communication between the module and the drive is activated with Parameter 98.06 AI/O EXT MODULE.

### **Basic Checks**

Ensure the ACS 600 is:

- installed and commissioned, and
- the external start and stop signals are connected.

Ensure the NAIO Module:

- settings are adjusted. (See the *NAIO Settings* below.)
- is installed and reference signal is connected to AI1.
- is connected to ACS 600.

### **NAIO Settings**

Set the module node address to 5.

Select the signal type for the input AI1 (DIP switch).

Select the operation mode of the NAIO-03 module (DIP switch). In NAIO-01 and NAIO-02 module the modes are fixed. See the table below.

Mode	NAIO-01	NAIO-02	NAIO-03
Unipolar	x	-	x
Bipolar	-	x	x

**Note:** Ensure the drive parameter setting corresponds to the mode of the NAIO module (98.06 AI/O EXT MODULE).

### **ACS 600 Parameter Settings**

Set the ACS 600 parameters (see the appropriate subsection on the following pages).

**Bipolar Input in Basic Speed Control**

The table below lists the parameters that affect the handling of the speed reference received through the NAIO module bipolar input AI1.

Parameter	Setting
98.06 AI/O EXT MODULE	BIP AIO PRG; BIP AO PRG; BIPOLAR
10.03 DIRECTION	FORWARD; REQUEST <sup>(1)</sup> ; REVERSE
11.02 EXT1/EXT2 SELECT (O)	EXT1
11.03 EXT REF1 SELECT (O)	<b>AI2</b>
11.04 EXT REF1 MINIMUM	<i>minREF1</i>
11.05 EXT REF1 MAXIMUM	<i>maxREF1</i>
13.06 MINIMUM AI2	<i>minAI1</i>
13.07 MAXIMUM AI2	<i>maxAI1</i>
13.08 SCALE AI2	100%
13.10 INVERT AI2	NO
30.01 AI<MIN FUNCTION	<sup>(2)</sup>

1) For the negative speed range, the drive must receive a separate reverse command.  
 2) Set if supervision of living zero is used.

The figure below represents the speed reference corresponding to the NAIO module bipolar input AI1.

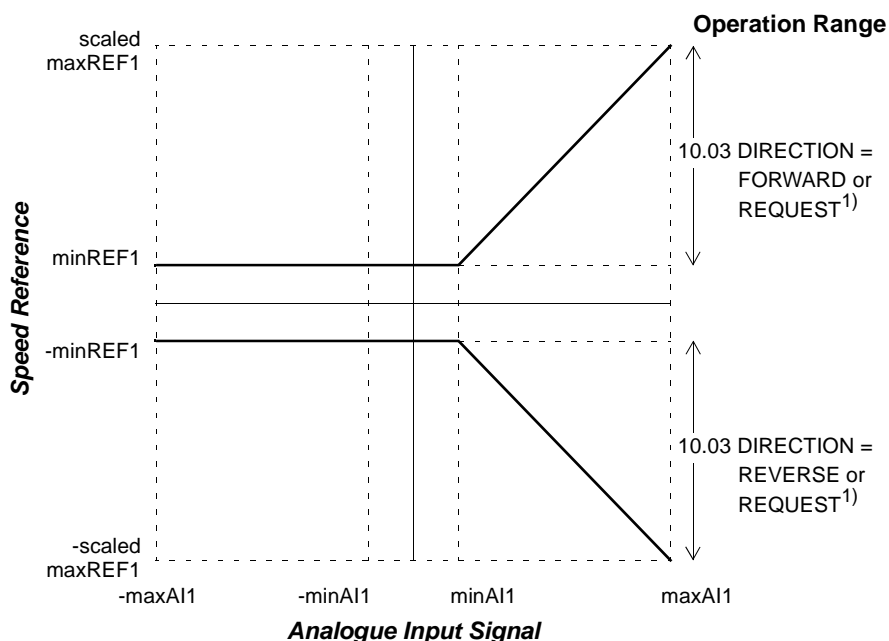

- minAI1 = 13.06 MINIMUM AI2 (i.e. NAIO AI1)
- maxAI1 = 13.07 MAXIMUM AI2 (i.e. NAIO AI1)
- scaled maxREF1 = 13.08 SCALE AI2 x 11.05 EXT REF1 MAXIMUM
- minREF1 = 11.04 EXT REF1 MINIMUM

**Bipolar Input in Joystick Mode**

The table below lists the parameters that affect the handling of the speed and direction reference received through the NAIO module bipolar input AI1.

Parameter	Setting
98.06 AI/O EXT MODULE	BIP AIO PRG; BIP AO PRG; BIPOLAR
10.03 DIRECTION	FORWARD; REQUEST <sup>(1)</sup> ; REVERSE
11.02 EXT1/EXT2 SELECT (O)	EXT1
11.03 EXT REF1 SELECT (O)	<b>AI2/JOYST</b>
11.04 EXT REF1 MINIMUM	<i>minREF1</i>
11.05 EXT REF1 MAXIMUM	<i>maxREF1</i>
13.06 MINIMUM AI2	<i>minAI1</i>
13.07 MAXIMUM AI2	<i>maxAI1</i>
13.08 SCALE AI2	100%
13.10 INVERT AI2	NO
30.01 AI<MIN FUNCTION	<sup>(2)</sup>

<sup>1)</sup> Enables the use of both positive and negative speed range.

<sup>2)</sup> Set if supervision of living zero is used.

The figure below represents the speed reference corresponding to the NAIO module bipolar input AI1 in joystick mode.

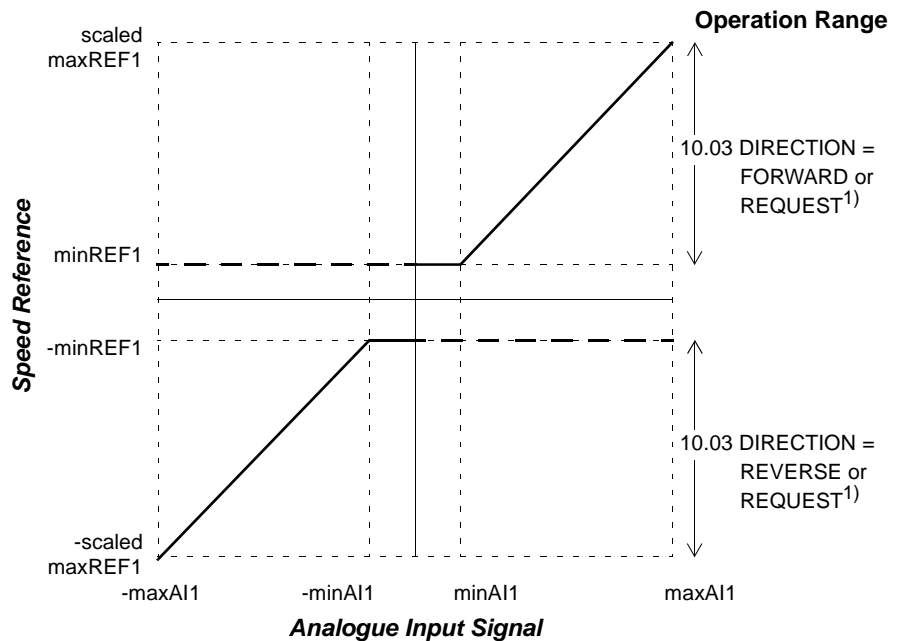

- minAI1 = 13.06 MINIMUM AI2 (i.e. NAIO AI1)
- maxAI1 = 13.07 MAXIMUM AI2 (i.e. NAIO AI1)
- scaled maxREF1 = 13.08 SCALE AI2 x 11.05 EXT REF1 MAXIMUM
- minREF1 = 11.04 EXT REF1 MINIMUM





<b>A</b>		<b>K</b>	
ACC COMPENSATION	6-44	Keypad control	2-13
ACC/DEC RAMP SHPE	6-39	Keypad reference	6-5
Actual Signals			
full name	2-5		
AI MIN FUNCTION	6-53		
APPL SW VERSION	6-66		
<b>C</b>		<b>L</b>	
Constant speeds	5-16, 6-11	Language	3-2
Not considered	4-5, 5-10, 5-14	Living zero	6-53
Contrast setting	2-10	Local	2-3, 2-13, 4-4
Control location			
indication on display	2-13		
selecting	4-5		
Control operation	C-1, D-1		
Control source			
selecting	4-5		
CONTROL SW VERSION	6-66		
<b>D</b>		<b>M</b>	
DC HOLD	6-35, 6-37	Motor ID Run	3-4, 3-5
Direction	2-3, 6-4	Motor overload protection	6-54, 6-82, 6-85, 6-86, 6-91
		MOTOR PHASE LOSS	6-59
<b>E</b>		<b>O</b>	
External control	2-13, 4-5, 6-2, 6-6	OVERVOLTAGE CTRL	6-32
EXTERNAL FAULT	6-53		
<b>F</b>		<b>P</b>	
Fault History	2-4, 4-4	PANEL LOSS	6-53
Fault reset	2-4, 6-29	PARAMETER LOCK	6-28
Faults	2-4, 7-1	Parameters	
Firmware version	6-66	changing value	2-8
First display	2-4	copying	2-11
FLUX BRAKING	6-49	downloading	2-9
FLUX OPTIMIZATION	6-49	restoring	3-2
		uploading	2-9
		Program version	6-66
<b>I</b>		<b>R</b>	
ID-number	2-3	Reference	
Integer scaling	C-1, D-1	connection	6-6
IR COMPENSATION	6-50, 6-51	setting	2-14
		Remote	2-3, 2-13
		<b>S</b>	
		Serial communication	6-105, 6-106, 6-107
		START FUNCTION	6-34
		Starting the drive	2-13, 6-2
		Status Row	2-3
		Status row	2-3, 2-13
		STOP FUNCTION	6-35
		Stopping the drive	2-13, 6-2

**T**

TEST DATE 6-66

**U**

UNDERLOAD FUNC 6-58

UNDERVOLTAGE CTRL 6-32

USER MACRO IO CHG 6-29

User unit 6-67

**V**

Version 6-66

**W**

Warnings 2-4, 7-1



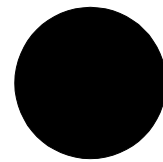

3AFY 61201441 R0725 EN  
EFFECTIVE: 16.10.2000

---

ABB Industry Oy  
Drives  
P.O. Box 184  
FIN-00381 HELSINKI  
FINLAND  
Telephone: +358-10 22 2000  
Telefax: +358-10-22 22681  
Internet: <http://www.abb.com/automation>