

# SIEMENS

## SIMATIC S5-101U

### Programmable Controller

Instructions

Order No.: EWA 4NEB 810 2119-02c

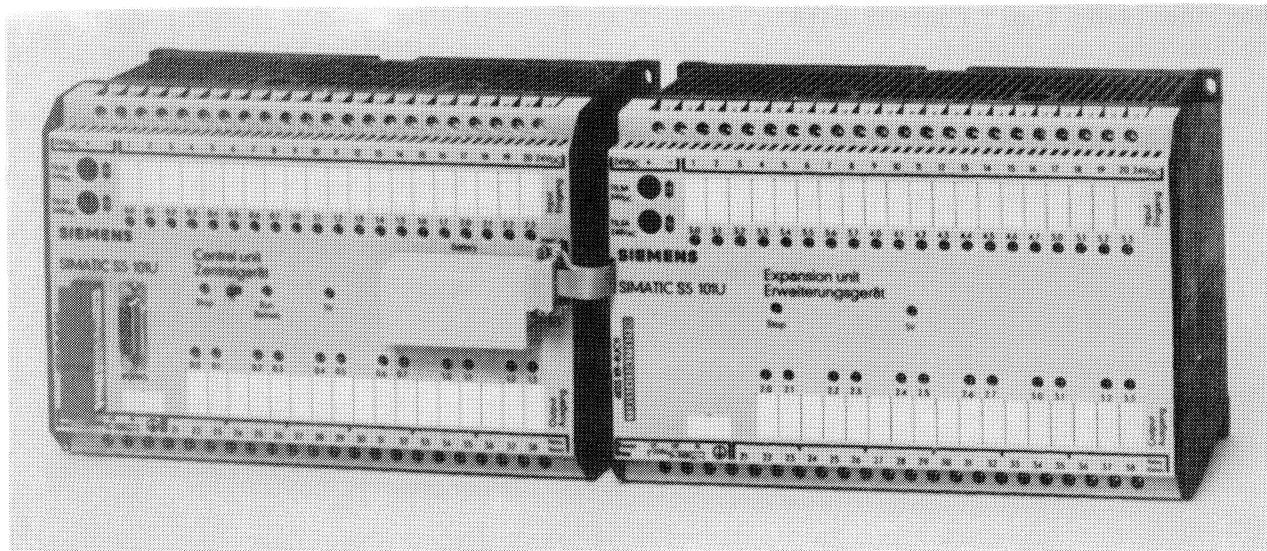

Fig. 1 S5-101U Programmable controller

CONTENTS	Page		Page
1. DESCRIPTION		3. START-UP AND OPERATION	
1.1 Application	1.1	3.1 Controls and displays	3.1
1.2 Design	1.1	3.2 The "Run" and "Stop" modes	3.1
1.3 Principle of operation	1.2	3.3 Power-up	3.2
		3.4 Using the memory submodules	3.2
		3.5 Operation with the expansion	3.3
2. INSTALLATION		3.6 Operation in the SINEC L1	3.4
2.1 Mechanical construction	2.1	3.7 Start-up	3.5
2.2 Electrical design	2.2	4. MAINTENANCE AND REPAIR	
2.2.1 Installation guidelines	2.2	4.1 Error/Fault diagnosis	4.1
2.2.2 Connection of the expansion	2.3	4.2 Interrupt stack	4.2
2.3 Terminal assignments of the	2.4	4.3 Changing the backup battery	4.3
central controller (CC)		4.4 Interface assignments	4.4
2.3.1 Relay version (with full	2.5	5. TECHNICAL SPECIFICATIONS	
complement)		5.1 General data	5.1
2.3.2 Relay version (with partial	2.6	5.2 CPU/memory submodule	5.2
complement)		5.3 I/Os	5.2
2.3.3 TRIAC version	2.7		
2.3.4 Transistor version	2.8	6. SPARE PARTS AND ACCESSORIES	6.1
2.4 Terminal assignments of the	2.8		
expansion unit (EU)			
2.4.1 Relay version	2.9		
2.4.2 TRIAC version	2.10		
2.4.3 Transistor version			

# 1. Description

## 1.1 Application

The 101U is a programmable controller (PC) of the SIMATIC S5 system. It was developed as a compact PC for automation tasks in the lower performance range as an economical replacement for up to 10 relays or contactors. The PC can be used for applications involving logic control with timing and counting functions. The PC is programmed with the hand-held 605U programmer, using statement lists (STL) or with the 670/675 CRT-based programmers in all three methods of representation, namely, statement list (STL), ladder diagram (LED) and control system flowchart or function chart (CSF).

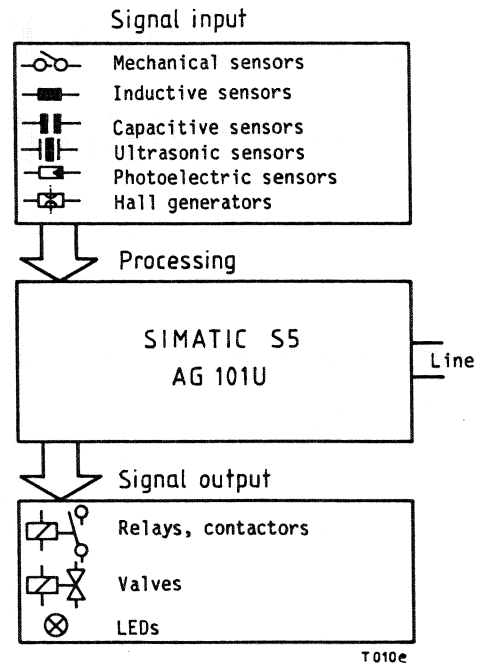

Fig. 2: Applications of the S5-101U programmable controller

## 1.2 Design

Compact PC for cabinet and wall mounting.

Screw-type terminals are used for all connections as in contactor systems (SIGUT SYSTEM)

Internal power supply for sensors in the relay version; no external sensor supply necessary

Receptacle for external memory sub-module

Connector for programmer or SINEC L1 (TTY interface)

Power terminals

Connector for expansion unit for doubling the number of inputs and outputs

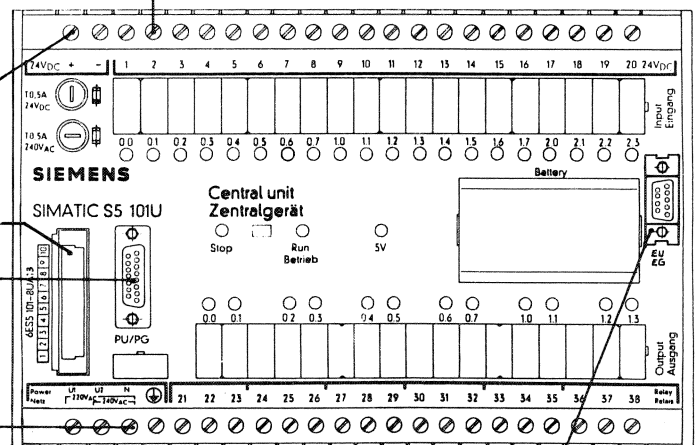

Fig. 3: S5-101U programmable controller (relay version)

## 1.3 Principle of operation

### CENTRAL PROCESSING UNIT (CPU)

The CPU consists of a single-chip micro-computer and performs the following functions:

- Program processing
- Scanning of inputs and outputs (coils)
- Driving of outputs
- Programming of the memory submodule (EEPROM only)
- Servicing the serial port when a programmer is connected

### INTERNAL MEMORY

The user program (up to 1024 statements) is stored in the internal memory. This memory also includes an area for the process I/O image. The internal memory can be supported by a backup battery.

### EXTERNAL MEMORY SUBMODULE

- The user program is dumped in an external memory submodule for long-term storage (without battery backup being required). Both an EPROM and an EEPROM submodule are available:
- The EPROM submodule can only be programmed with the PG670/PG675 programmer. The EPROM can be erased with ultraviolet light.
  - In the case of the EEPROM submodule, the program is stored and erased direct on the PC with the aid of the programmer

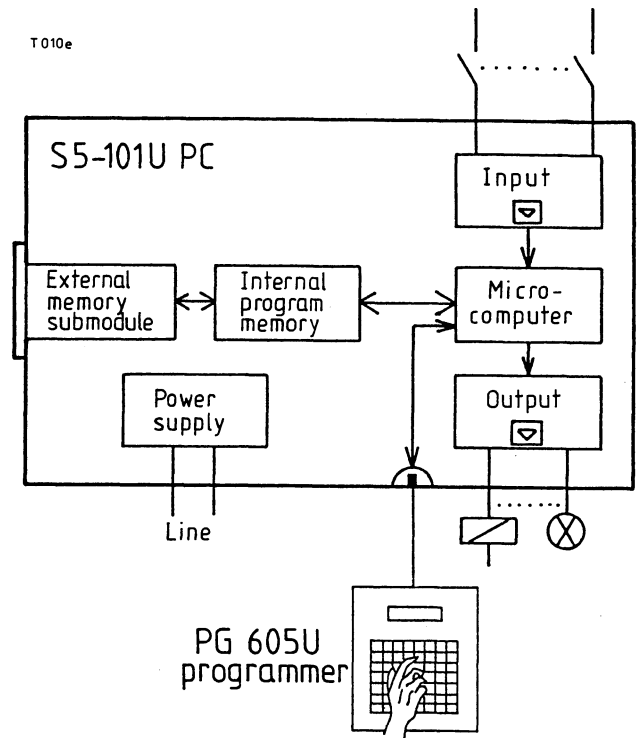

Fig. 4: Block diagram of the S5-101U

## PROGRAM PROCESSING

The control functions of the S5-101U are defined by a user program. In order to be able to scan the user program cyclically statement by statement, the CPU performs the following functions:

1. In the case of a cold restart (power switch from "Off" to "On" or mode selector from "Stop" to "Run"), the process output image\* is erased, i.e. all outputs are set to zero.
2. The process input image\* is updated, i.e. all signal statuses of the inputs are scanned and written into the process input image.
3. The user program (PB1 or FB1) is scanned and processed statement by statement. When scanning the signal statuses of the inputs, the CPU accesses the process input image and not the actual inputs. When latching and unlatching the outputs (coils), only the process output image is overwritten to begin with.
4. Once the user program has been processed, the process output image is transferred to the actual outputs.
5. Points 2, 3 and 4 are handled cyclically.

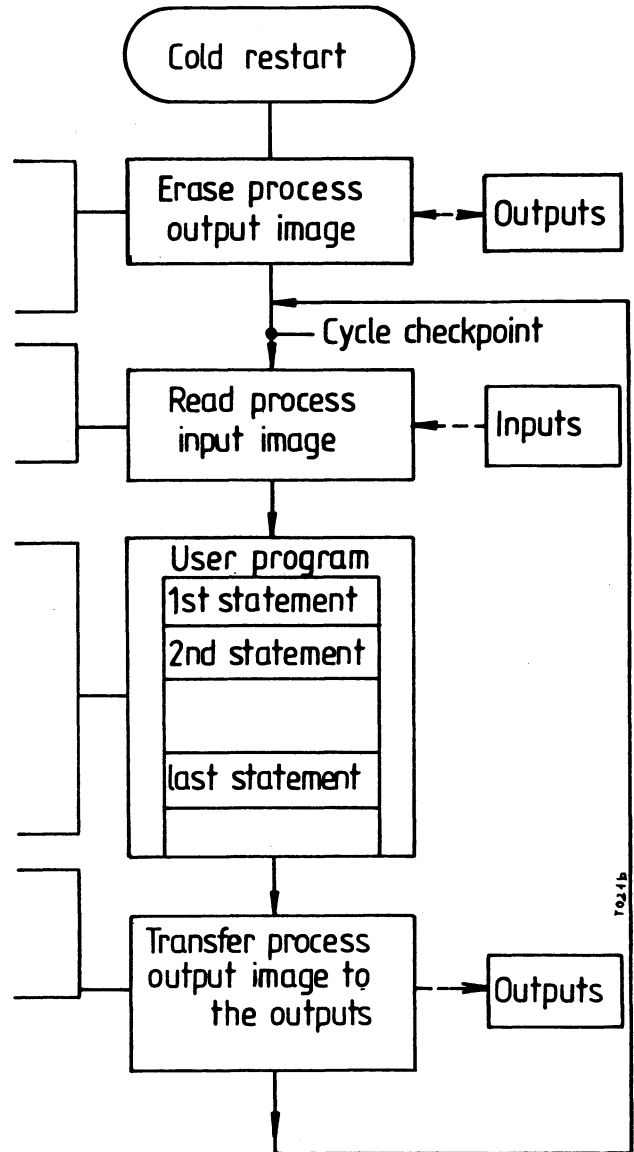

Fig. 5: Principle of operation of the S5-101U

A scanning operation from cycle checkpoint to cycle checkpoint takes approx. 70 ms for 1024 statements (binary).

If a scanning cycle is not completed within 300 ms due to program errors or faults, an internal monitor responds, the PC enters the "Stop" status and all outputs (coils) are switched off.

\*Process I/O image:

Internal memory area in which the signal status ("0" or "1") of the inputs/outputs is stored.

## 2. Installation

### 2.1 Mechanical construction

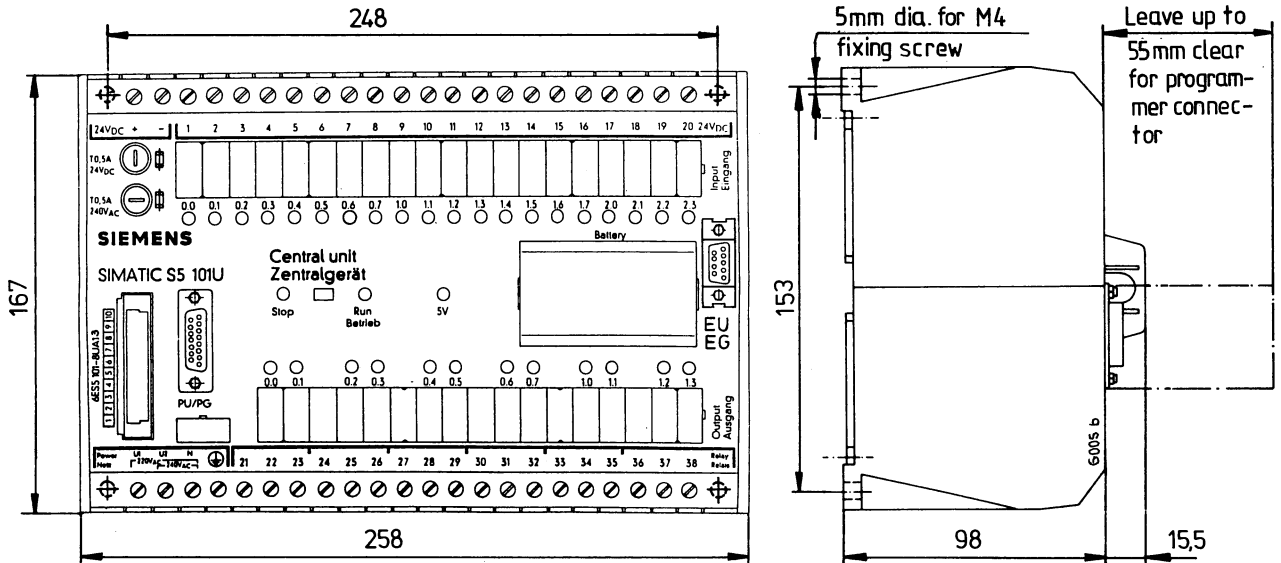

Fig. 6: Dimension diagram of the 101U

The S5-101U central controller (CC) and the S5-101U expansion unit (EU) both have the same dimensions.

Both units are attached side by side to a vertical mounting surface by means of four M4 bolts.

The inputs and outputs must be at the top and bottom (i.e. the units must not be turned through 90 deg.).

When installing the units, make sure that the maximum clearance of 30 mm is not exceeded.

In order to avoid the accumulation of heat, make sure

- that the maximum angle of inclination of 22.5 deg. is not exceeded
- that the minimum clearance of 200 mm between units mounted one above the other is observed.

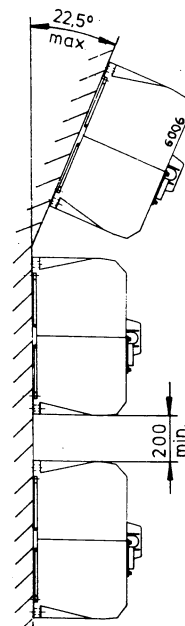
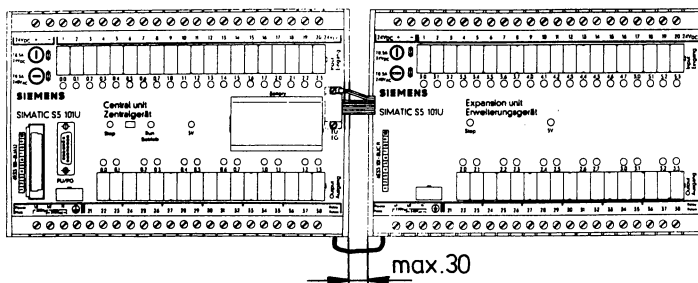

Fig. 7: Wall mounting arrangements

## 2.2 Electrical design

Screw-type terminals are used on the S5-101U for all electrical connections. Each terminal can take two conductors with the following cross-sectional areas:

Solid conductors	1 ...2.5mm <sup>2</sup> (17 to 13 AWG)
Stranded conductors	0.75...1.5mm <sup>2</sup> (18 to 15 AWG)
(with core end sleeves)	

The screws should be tightened with a torque of between 80 and 120 Ncm. 10 mm of insulation should be removed from the end of the leads.

### 2.2.1 Installation guidelines

The PC and field devices (sensors and actuators) should be connected up as shown below (Example: CC (relay version) and EU (Triac version) connected to a common phase):

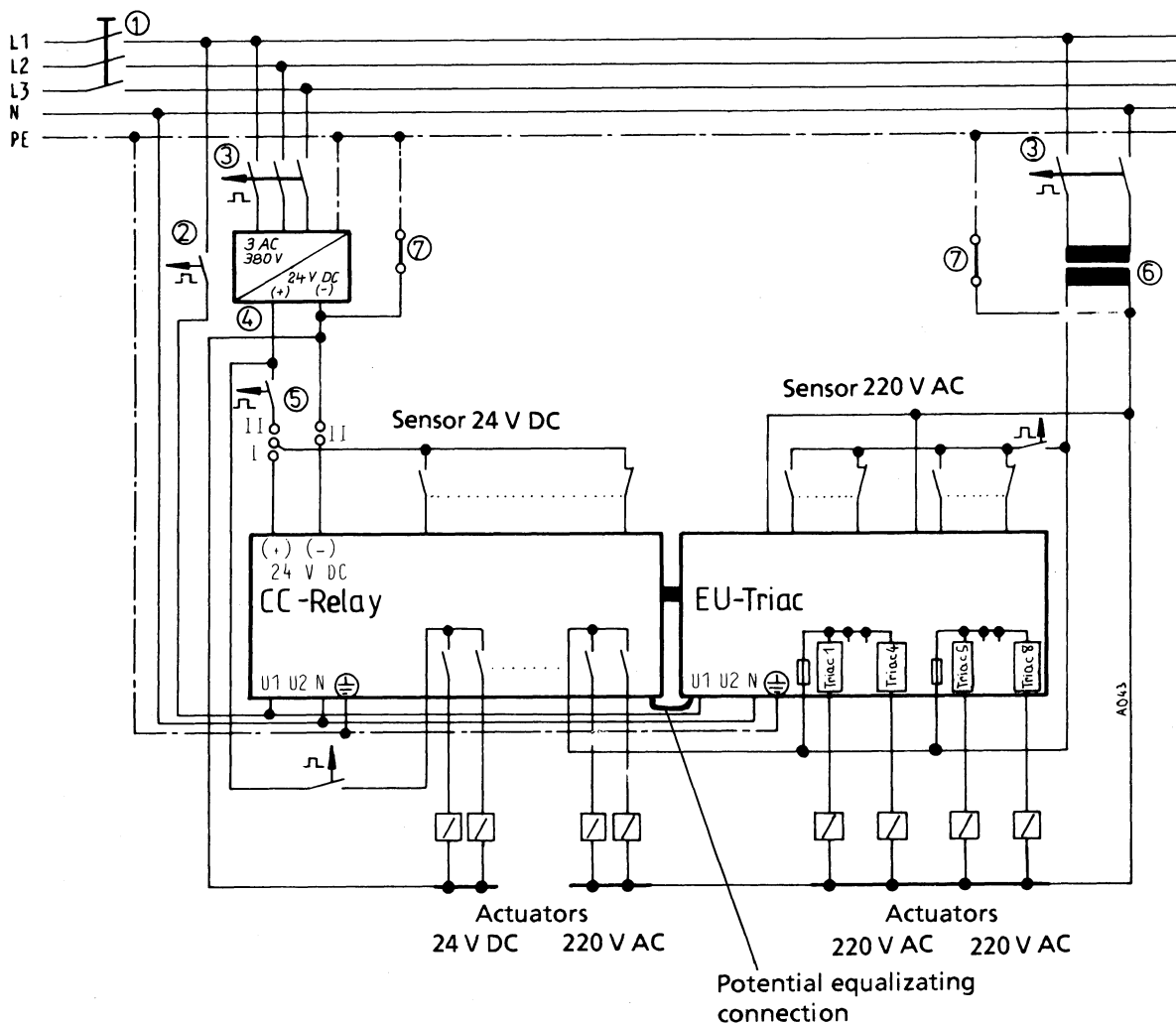

Fig. 8: Installation schematic for the S5-101U PC and field devices

When connecting up the PC, the following points should be noted:

- A common main switch (1) to VDE 0113 or isolating facility to VDE 0100 must be provided for the PC, sensors and actuators.
- The power connections of the CC and the EU must have a common fuse (max. fuse rating 6 A) (2).  
The CC and EU need only be fused separately if they are connected to different phases.
- Make sure that the power connection and the inputs and outputs of the same unit are not connected to different phases.
- A smaller conductor cross-sectional area can be used without fuses (3) for the power connection of the control circuits if the connecting line is less than 3 m long and is proof against earth faults and short-circuits.
- The power leads and I/O cabling must be run separately.
- A power supply unit (4) must be provided for the 24 V control circuits. 24 V lines must not be combined with lines carrying higher voltages in a common cable.  
The sensors (5) can be powered by the 24 V DC/300 mA power supply unit in the PC (connection I) or by an external 24 V power supply unit (connection II).

## 2.2.2 Connection of the expansion unit

The 101U central controller and S5-101U expansion unit are connected to each other by a short flat ribbon cable.

Sufficient contact to chassis ground is ensured by securing the Cannon connector (1) with two screws (2). The tightening torque of the screws should be 25...30 Ncm. Only use M3x8 screws.

Switch off the power supply before interconnecting or disconnecting the central controller and the expansion unit.

The potential equalization conductor of the EU must be connected to the CC. Contact is established by a fixing screw on the CC.

- In control circuits with more than five actuating coils, galvanic isolation by means of a control transformer (6) is recommended.
- Auxiliary circuits should be earthed either at one end (actuators and sensors must be arranged accordingly) or non-earthed auxiliary circuits with an insulation monitor must be provided.  
Earthed operation by means of a strap (7) between the protective earth conductor and the power supply unit or transformer is to be preferred.
- When connecting up the signal leads or bundling such leads, make sure that the ventilating slots of the PC are not covered. This applies in particular to the ventilating slots above the screw terminals.
- Cables must not be run in the immediate vicinity of the frontplate, or between CC and EU.
- The programmable controller has a high immunity to noise so that contactors can normally be operated in its immediate vicinity without having to take any additional measures to reduce noise.
- Make sure that the relay contacts of the outputs are fitted with varistors (max. leakage current 1mA at 275 V<sub>rms</sub>).

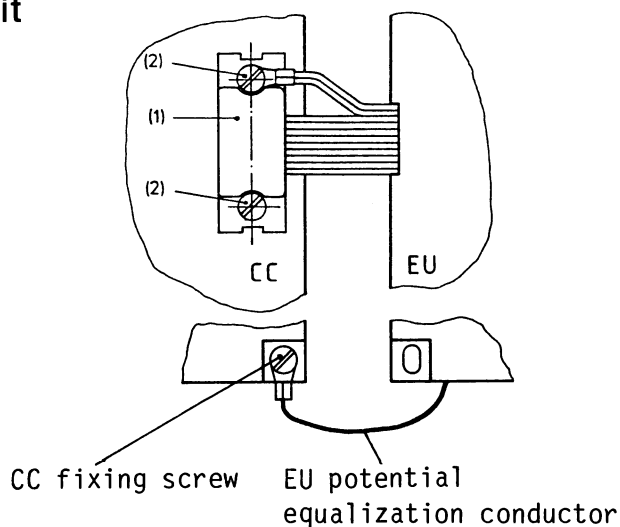

Fig. 9: Connection of the S5-101U expansion unit

## 2.3 Terminal assignments of the central controller (CC)

### 2.3.1 Relay version (with full complement)

(6ES5 101-8UA13)

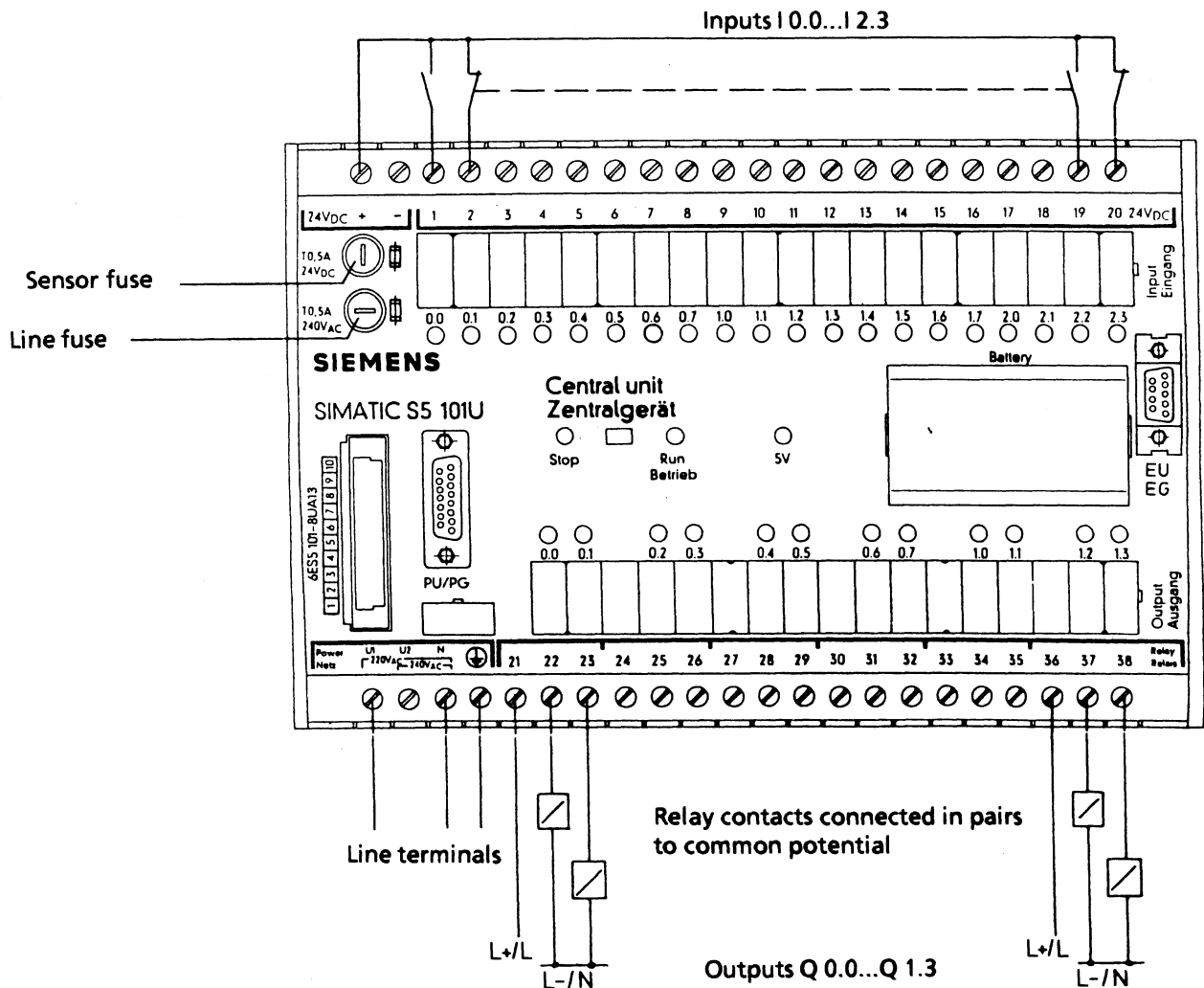

Fig. 10: Terminal assignments of the S5-101U central controller (CC) (relay version)  
Configuration: 20 inputs/12 outputs

Line connection:  
220 V or 240 V AC

V1: Phase (220 V AC)  
V2: Phase (240 V AC)  
N : Neutral  
⊕: Protective earth conductor

Sensor power supply:  
24 V DC (max. 300 mA)

The - 24 V DC terminal must be connected internally with the inputs:  
If an external 24 V power supply unit is used, its - 24 V DC terminal must be connected to the - 24 V DC terminal of the CC. The + 24 V DC terminal of the CC remains free in this case



## 2.3.2 Relay version (with partial complement)

(6ES5 101-8UB13)

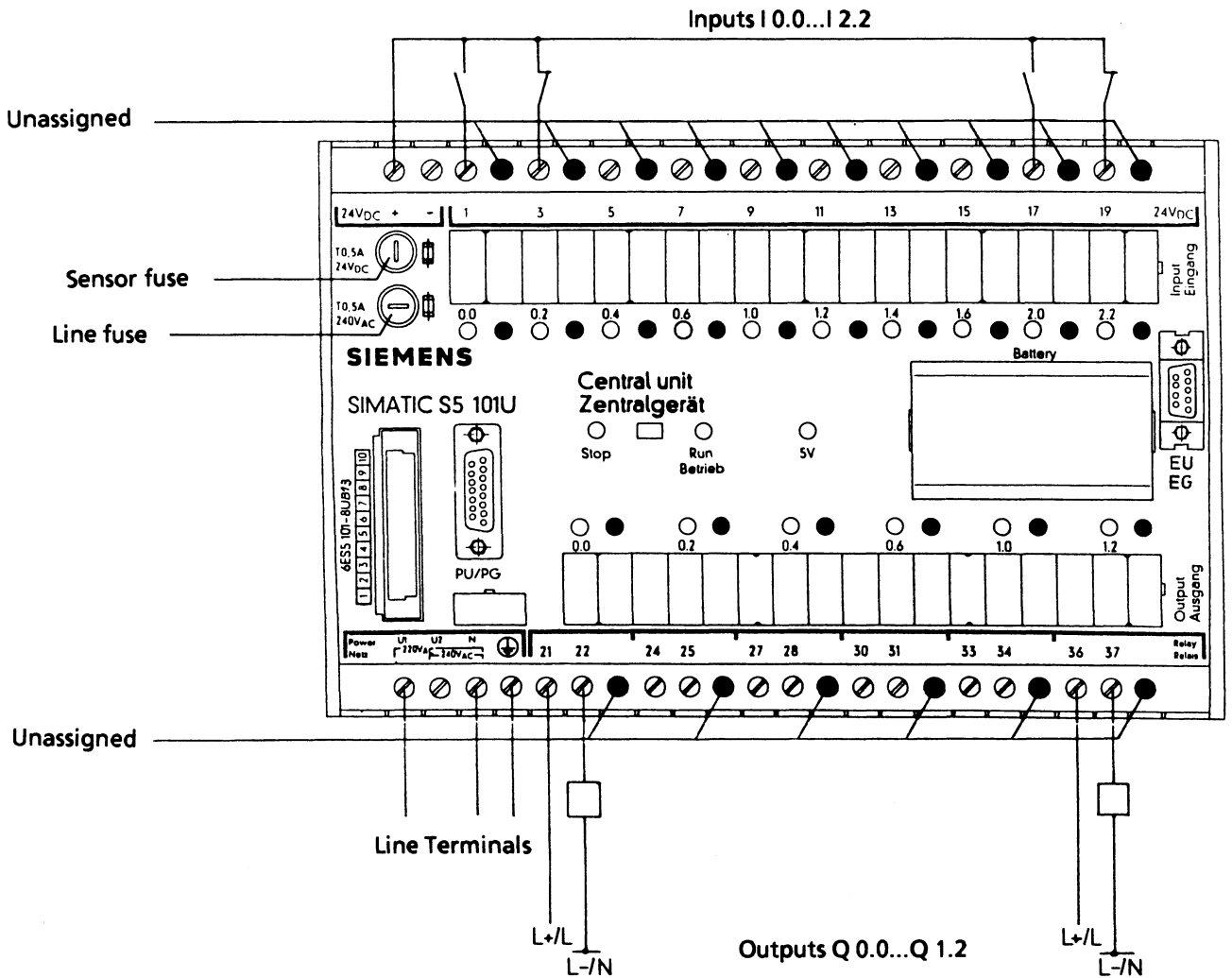

Fig. 11: Terminal assignments of the S5-101U central controller (relay version)  
Configuration: 10 inputs/6 outputs

### 2.3.3 TRIAC version (6ES5 101-8UA23)

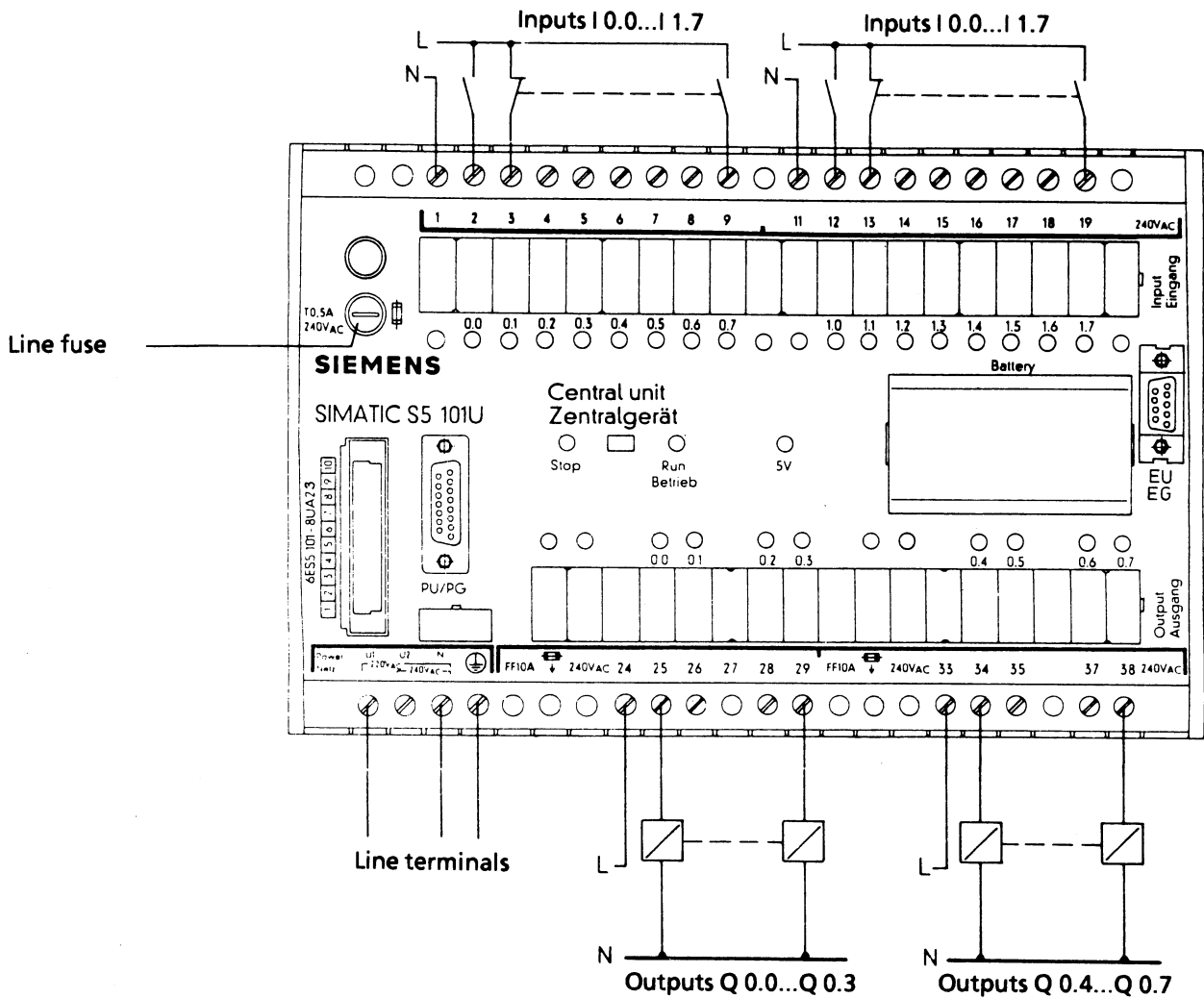

Fig. 12: Terminal assignments of the S5-101U central controller (Triac version)

Line connection:  
220 V AC or 240 V AC

- V1: Phase (220 V AC)
- V2: Phase (240 V AC)
- N: Neutral
- ⊕: Protective earth conductor

Eight inputs or four outputs connected to common potential.

Inputs/outputs and line terminal must be connected to a common phase.

## 2.3.4 Transistor version (6ES5 101-8UA33)

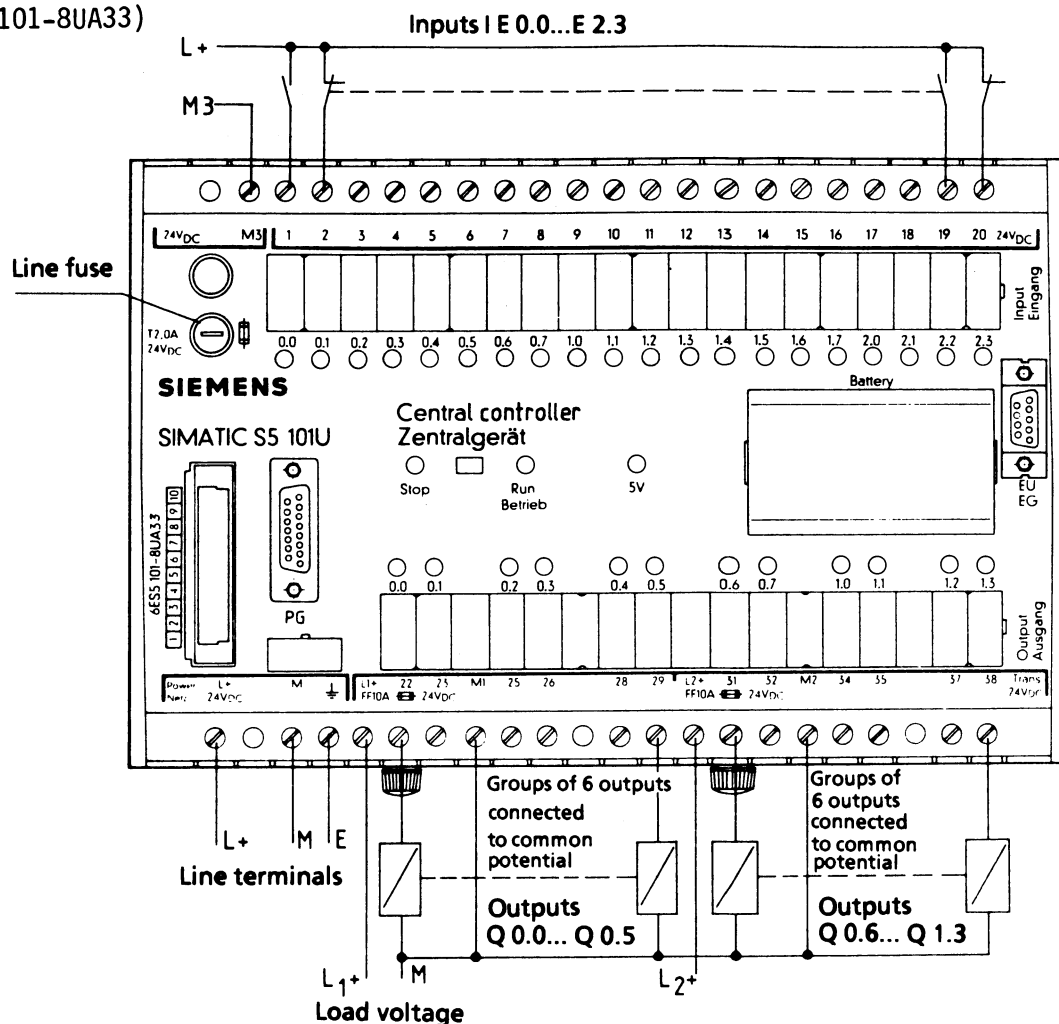

Fig. 13: Terminal assignments of the S5-101U central controller  
(Transistor version)  
Complement: 20 inputs/12 outputs

Line connection:

L+: 24 V DC (positive)  
M: Reference voltage from L+ 0 V DC  
⊥: System ground

-Connections M, M<sub>1</sub>, M<sub>2</sub>, M<sub>3</sub> and E  
are connected internally.

-M, M<sub>1</sub>, M<sub>2</sub>, M<sub>3</sub> and E must also be  
connected externally to improve the  
current carrying capacity.

Sensor supply voltage:  
24 V DC/min 0..3 A

Load voltage: 24 V DC

-The load voltage, sensor voltage and  
line voltage can be taken from a  
common source.

## 2.4 Terminal assignments of the expansion unit (EU)

### 2.4.1 Relay version (6ES5 101-8UC11)

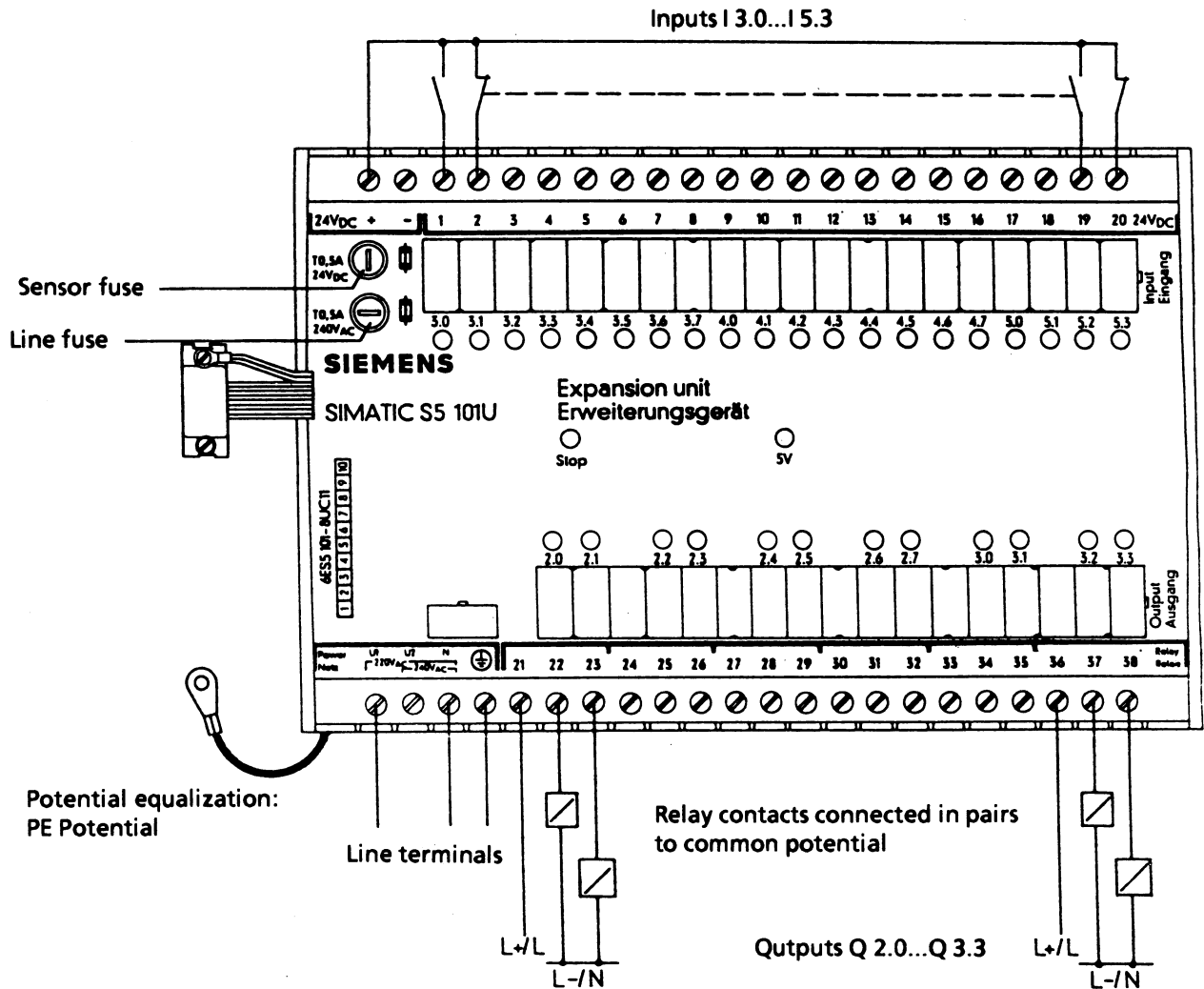

Fig. 14: Terminal assignments of the S5-101U expansion unit (relay version)

Line connection:  
220 V or 240 V AC

Sensor power supply:  
24 V DC (max. 300 mA)

V1: Phase (220 V AC)

V2: Phase (240 V AC)

N: Neutral

⊕: Protective earth conductor

## 2.4.2 TRIAC version (6ES5 101-8UC21)

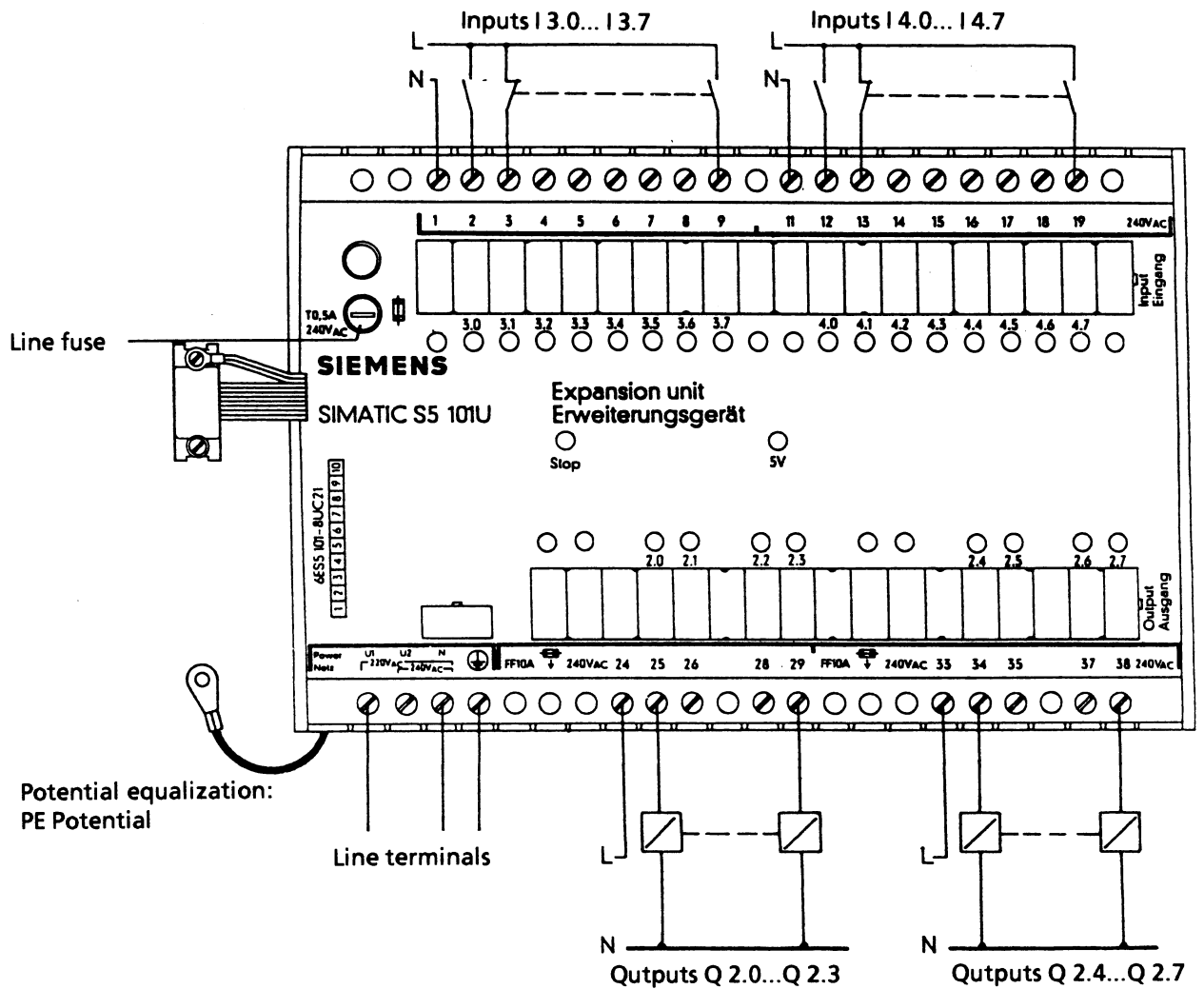

Fig. 15: Terminal assignments of the S5-101U expansion unit (Triac version)

Line connection:  
220 V or 240 V AC

V1: Phase (220 V AC)  
V2: Phase (240 V AC)  
N: Neutral  
⊕: Protective earth conductor

Eight inputs or four outputs connected to common potential.

Inputs/outputs and line terminal must be connected to a common phase.

## 2.4.3 Transistor version (6ES5 101-8UC31)

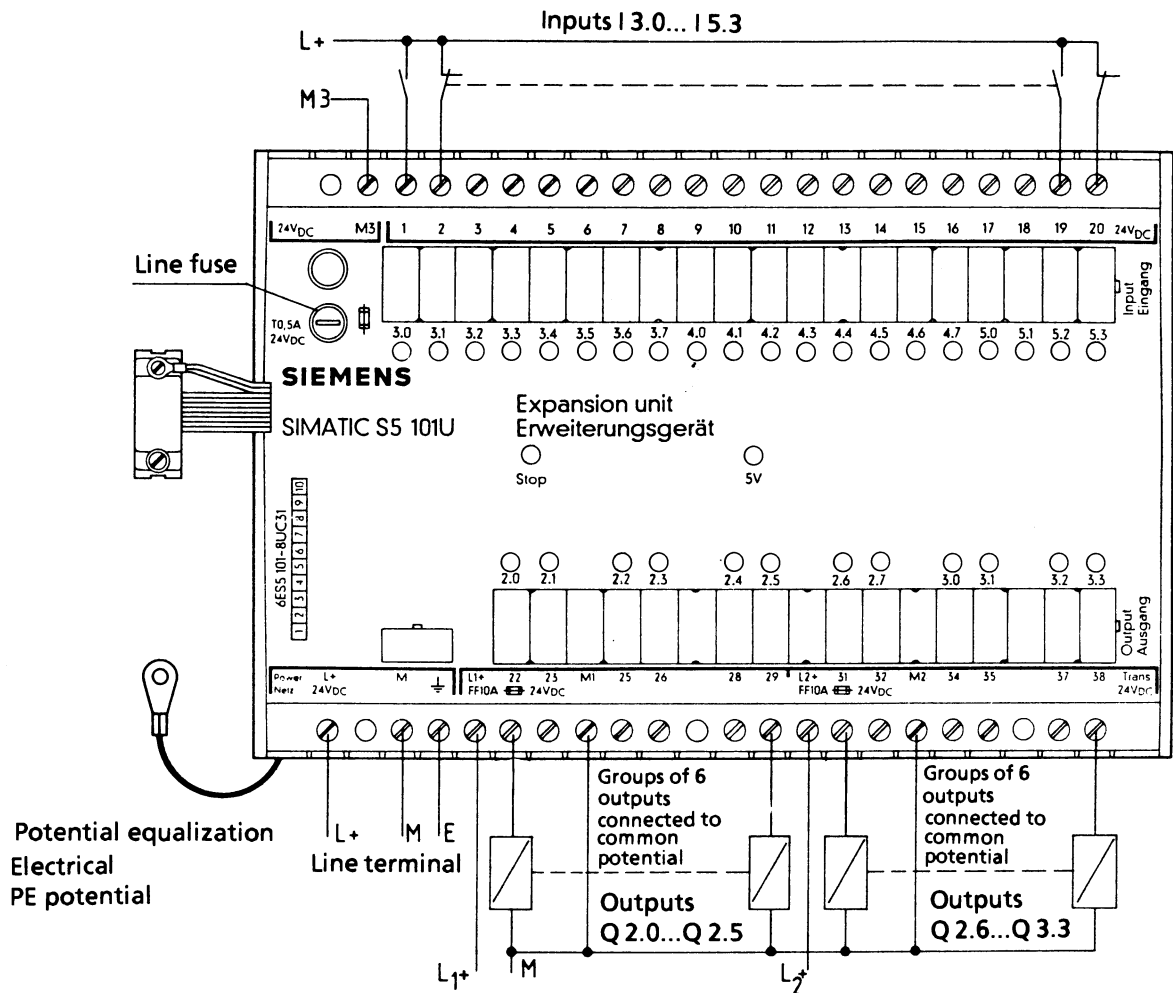

Fig. 16: Terminal assignments of the S5-101U expansion unit  
(Transistor version)  
Complement: 20 inputs/12 outputs

Line connection:

Load voltage: 24 V DC

L+: 24 V DC (positive)

M: Reference voltage from L+ 0 V DC

⊥: System ground

-The load voltage, sensor voltage and line voltage can be taken from a common source.

-Connections M, M<sub>1</sub>, M<sub>2</sub>, M<sub>3</sub> and E are connected internally.

-M, M<sub>1</sub>, M<sub>2</sub>, M<sub>3</sub> and E must also be connected externally to improve the current carrying capacity.

Irrespective of the operating mode, terminal E of the expansion unit must be connected to terminal E of the central controller.

# 3. Start - up and operation

## 3.1 Controls and displays

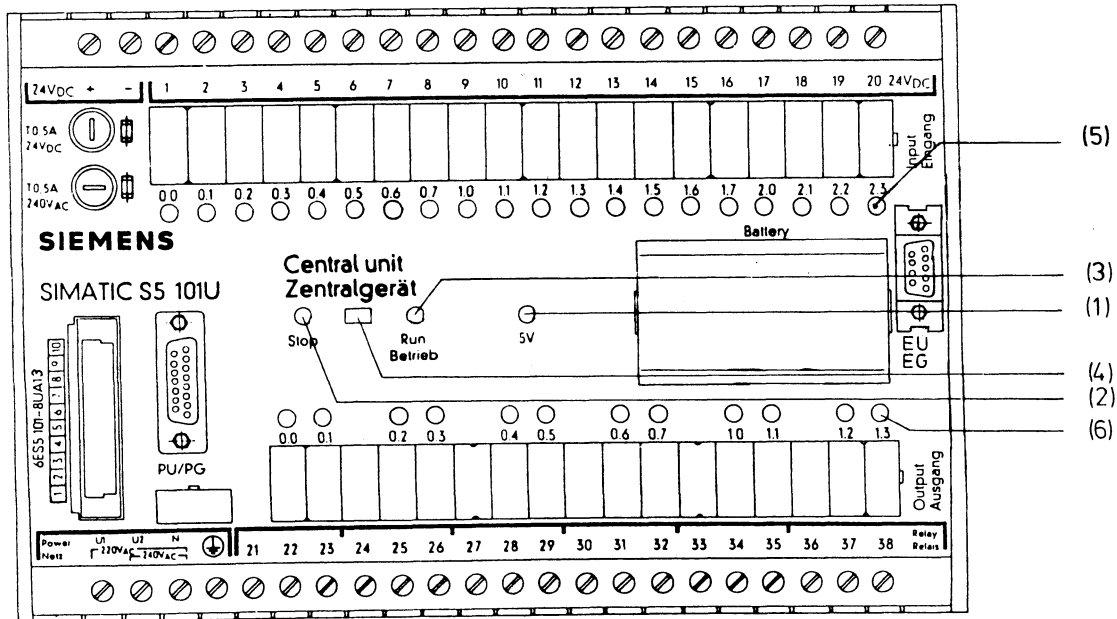

Fig. 17: Controls and displays of the 101U PC

The green "5V" LED (1) indicates that the internal power supply for the PC is available. The red "Stop" LED (2) and the green "Run" LED (3) indicate the two operating states of the PC. The "Stop" and "Run" operating states are selected with the mode selector (4)

The green LEDs for the inputs (5) light up when the "1" signal is applied to the input terminals and thus indicate the signal state of the inputs direct. The green LEDs for the outputs (6) are connected in parallel with the excitation coils of the output relays or the drivers of the outputs and indicate the signal status of the outputs.

## 3.2 The "Run" and "Stop" modes

The 101U PC has two operating modes - "Stop" and "Run". In the "Stop" mode - red LED (2) illuminated - the user program is not processed. All outputs or coils are disabled in this mode. The PC automatically enters the "Stop" state when faults or errors occur that prevent proper processing of the program.

The "Stop" status of the PC can be exited again by turning the mode selector (4) to the "Run" position. The red LED (2) darkens and the green LED (3) lights up. The program is processed in this mode. When the mode selector (4) is in the "Run" position, the operating state of the PC can be modified additionally by the "PC stop" and "PC start" functions of the programmer.

### 3.3 Power - up

When the power supply is switched on or on recovery of power following a power failure, the PC assumes the operating modes shown in Fig. 18.

A restart following power-up can be suppressed by the user program (see Programming instructions, Section 3.2).

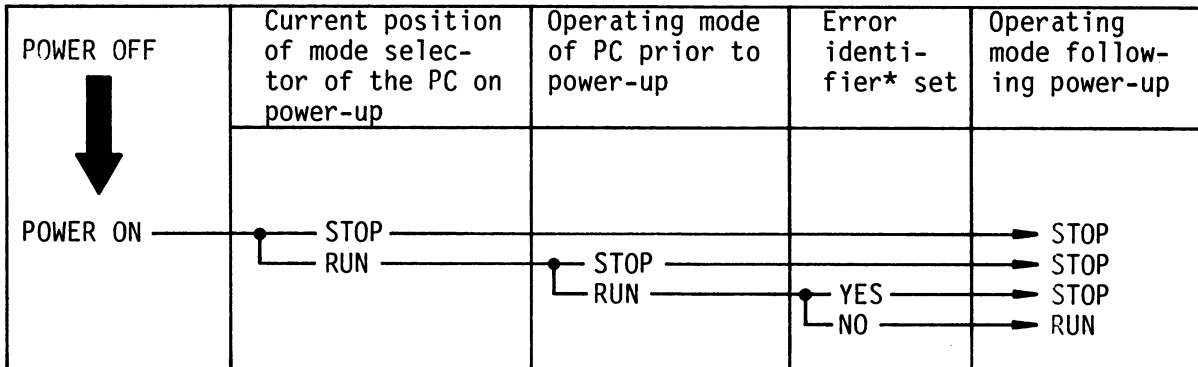

Fig. 18: Automatic mode setting following power-up

\* see interrupt stack (Section 4.2)

### 3.4 Using the memory submodules modules

There are two different memory submodules available for the S5-101U programmable controller (Fig. 19). The submodules are used for additional program dumping or for copying programs should only one memory module be used for several PCs.

When the power supply is switched on or the PC is switched to "Run", the contents of the submodule are copied into the internal memory (RAM) and processed from there. A backup battery provides support for at least three years in the event of a power failure.

Memory submodule	EPROM	EEPROM
Program dump	PG 615 (with adapter 984-2UA11) PG 670 (with adapter 984-0UA11) PG 675	PG 615 PG 670 (without 984 adapter) PG 675
Program erasure	Only with special UV lamp (erasure time: 30 min)	Direct in the PC with PG 605U/PG 615 PG 670/PG 675 (Programmer function: PG→PC)
Program modification by means of programmer	Only erasure of entire program possible	possible

Fig. 19: Differences between the EPROM and EEPROM submodules.



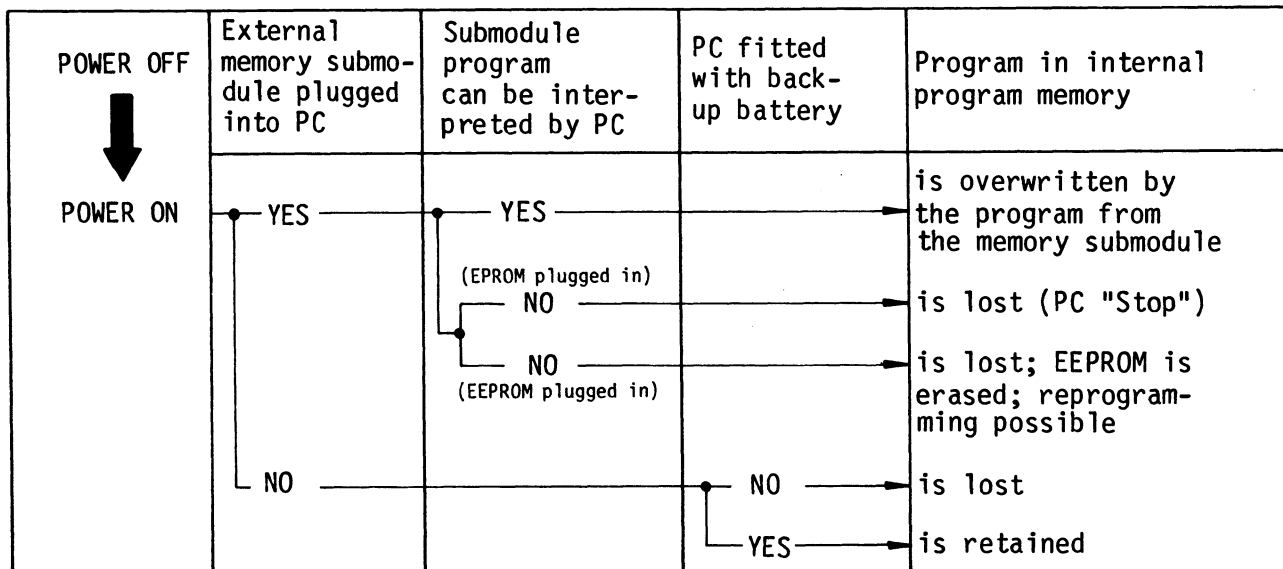

Fig. 20: PC power-up response with and without memory submodule

The dumping of the program on memory submodules is described in the Programming Instructions, Section "Program dump".

If various programs have been dumped in memory submodules, the relevant program can be executed in the PC simply by replacing the submodules.

Different programs can be loaded into the PC without the aid of a programmer by simply interchanging the memory submodules.

The PC always copies the program from the memory submodule into the internal program memory on power-up or on recovery of the power after a failure as well as when the mode selector is changed over to "Run". A program already in the program memory is overwritten even if the memory submodule plugged in is empty.

### 3.5 Operation with the expansion unit

The following points should be given special attention as the central controller (CC) and the expansion unit (EU) have separate power supply units:

- The outputs of the CC and the EU are disabled as soon as the PC enters the "Stop" state.
- In the event of a power failure in the CC, the EU automatically disables its outputs.
- In the event of a power failure in the EU, all inputs of the process I/O image which are assigned to the EU assume signal status "1".  
(not under undervoltage conditions)

The same applies in the case of a break in the bus connection between the CC and the EU. A fault in the EU can be detected by scanning input I 5.3.  
This only applies to total failure.

I 5.3 = "1": Fault in EU  
I 5.3 = "0": EU o.k.

If an expansion unit of the relay version transistor version is used, input I 5.3 must remain unconnected for this purpose.

### 3.6 Operation in the SINEC L1 local area network

The SINEC L1 local area network is used for interconnecting programmable controllers of the low-end performance range and operates on the Master-Slave principle. The CP 530 communications processor is always the master, and the slaves the CPUs of all small PCs.

A BT 777 bus terminal for signal level conversion is required for each node or station in the network. This terminal is connected to the programmer interface part of the slave or to the SINEC L1 part of the CP 530. A four-core shielded cable, which interconnects the various bus terminals, is used as the actual transmission medium. One master and up to 30 slaves can be connected to the SINEC L1 bus.

For further details, please refer to the Instructions and Programming Instructions of the SINEC L1 Local Area Network.

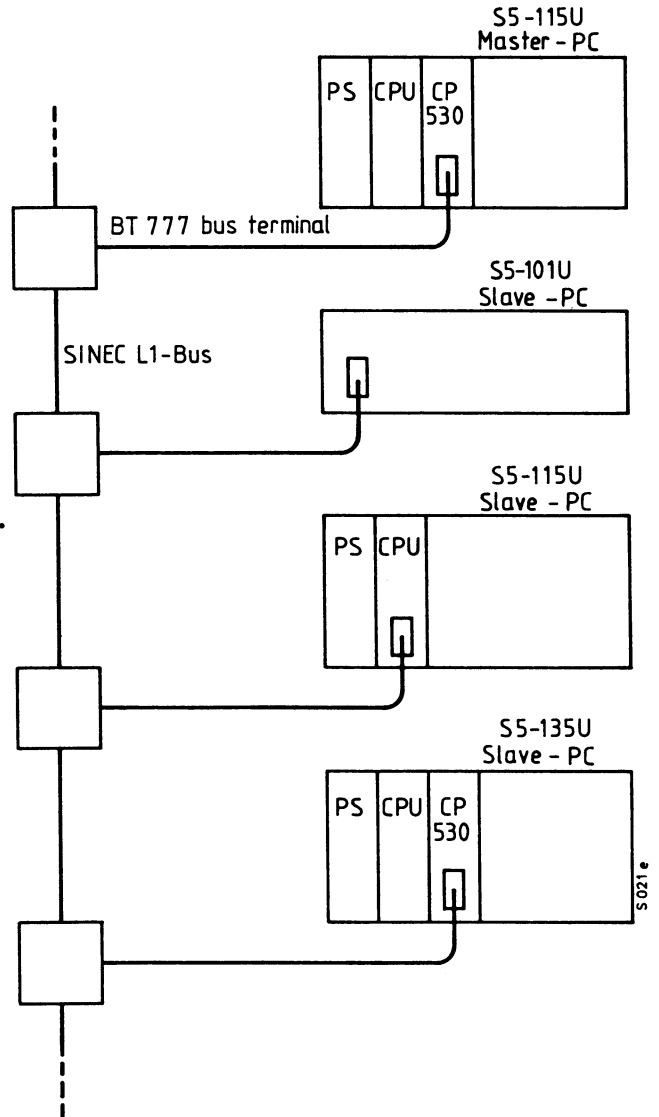

Fig. 20 a: Example of a SINEC L1 network

### 3.7 Start-up

On PC start-up, the following sequence of operator procedures must be observed.

Condition	Operator procedure	Remarks
Process and S5-101U PC dead, i.e. the main switch (see Fig. 8) is open.	<ul style="list-style-type: none"> <li>-Check power terminals (PE conductor must be connected)</li> <li>-Check whether all screw terminals are properly tightened</li> <li>-Make sure that there are no connections between 24V lines and lines carrying higher voltages.</li> <li>-Withdraw the memory submodule</li> </ul>	Visual check of the system, observing VDE 0100 and 0113.
Disconnect fuses for sensors and actuators. Switch off power circuits of the actuators. Close the main switch (see Fig. 8)	<ul style="list-style-type: none"> <li>-Switch PC to "Stop" without memory submodule and connect the PG 605U, 670 or 675 programmer.</li> <li>-Reset the PC with the programmer "ERASE PROGRAM" function and then set the PC to "Run"</li> </ul>	<p>When the main switch is closed, the green "5V" and red "Stop" LEDs light up.</p> <p>The red "Stop" LED darkens and the green "Run" lights up</p>
Insert the fuses for the sensors. The fuse for the actuators and power circuits remain disconnected.	<ul style="list-style-type: none"> <li>-Actuate all sensors one after the other.</li> </ul>	If the sensors are properly connected, the corresponding LEDs at the inputs will light up.
Insert the fuses for the actuators. The power circuits for the actuators remain disconnected (Fig. 8).	<ul style="list-style-type: none"> <li>-Each output of the I/Os can now be driven with the "Force" programmer function.</li> </ul>	The LEDs of the forced outputs light up and the switch positions of the relevant actuators change.
The power circuits for the actuators remain disconnected.	<ul style="list-style-type: none"> <li>-Put the PC to "Stop"</li> <li>-Enter the program with the aid of the programmer and transfer it to the PC</li> <li>- Put the PC to "Run", test and correct program.</li> <li>- Put the PC to "Stop".</li> </ul>	<p>The red "Stop" LED lights up.</p> <p>Set PC to "Stop" before debugging.</p>
When the program has been fully tested, switch on the power circuits for the actuators.	<ul style="list-style-type: none"> <li>-Put the PC to "Run"</li> </ul>	The PC must now process the program properly

# 4. Maintenance and repair

## 4.1 Error/Fault diagnosis

Most errors occur when entering and testing the program. In these cases, detailed error information is provided by the programmer. This is described in more detail in the operating instructions of the respective programmer.

The programmer has the following diagnostic functions for testing the program and for troubleshooting:  
 -"Program-independent signal status display"  
 (Programming instructions, Section 4)

-"Direct signal status display"  
 (Programming instructions, Section 4)  
 -Display of interrupt stack  
 (p. 4.2)

If the PC does not enter the "Run" state when the power is switched on or the mode selector is actuated, or should it leave the "Run" state during normal processing, the cause of the interrupt can be investigated with the programmer "DISPLAY I-STACK" function.

In the event of a fault on the 101U, the following troubleshooting procedure is recommended:

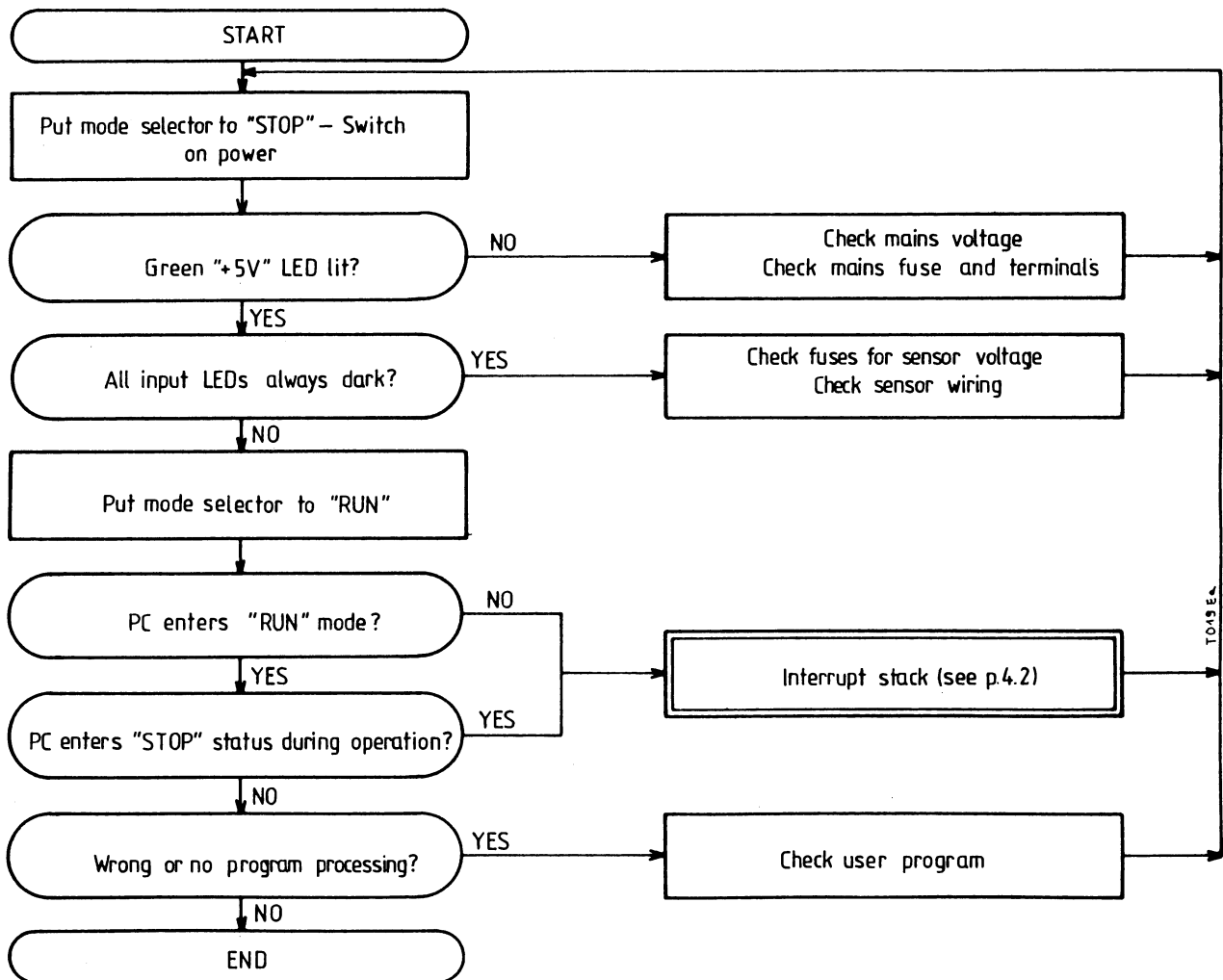

Fig. 21: Troubleshooting procedure

## 4.2 Interrupt stack

The interrupt stack (I-STACK) is a LIFO memory in which the operating system of the S5-101U enters the cause of the interrupt when the PC goes into the "Stop" state.

In the case of the PG670/PG675 CRT-based programmers, the I-STACK is displayed in the form of a table. With the hand-held PG 605U programmer, the I-STACK is called byte by byte. The following assignments apply:

BYTE		
1	∅	
2	∅	
3	STP ZUS	STP ANZ
4	∅	
5	ASP NEP	ASP NRA
6	∅	
7	∅	
8	∅	
9	STO SCH	∅
10	NAU	∅
11	∅	
12	∅	∅
13	∅	
14	∅	
15	∅	∅
16	∅	∅
17	∅	∅
18	∅	∅
19	∅	
20	∅	∅
21	∅	
22	∅	
23	∅	
24	∅	
25	∅	
26	∅	
27	∅	
28	∅	
29	∅	
30	∅	
31	∅	
32	∅	

SD5-HIGH	
SD5-LOW	
SD6-HIGH	System data word
SD6-LOW	
SD7-HIGH	System data word
SD7-LOW	
IRRELEVANT	
IRRELEVANT	
UAW-HIGH	Interrupt condition code word
UAW-LOW	
IRRELEVANT	
CONDITION CODES	
6th BRACKET LEVEL	
IRRELEVANT	
4th BRACKET LEVEL	
5th BRACKET LEVEL	
2nd BRACKET LEVEL	
3rd BRACKET LEVEL	
NESTING DEPTH	
1st BRACKET LEVEL	
IRRELEVANT	
IRRELEVANT	
IRRELEVANT	
IRRELEVANT	
SAZ-HIGH	Step address counter
SAZ-LOW	
OPERATION REGISTER- HIGH	
OPERATION REGISTER- LOW	
ACCU2-HIGH	
ACCU2-LOW	
ACCU1-HIGH	
ACCU1-LOW	

Read-out possible only when PC is in STOP state

Fig. 22: Interrupt stack

## Explanations in connection with the I-STACK

Byte 3	STPZUS: STPANZ:	PC at "Stop" (external; e.g. programmer) PC at "Stop" (internal)
Byte 5	KOPFNI: ASPNEP: ASPNEEP: ASPNRA:	Block header cannot be interpreted User EPROM User EEPROM User RAM (no submodule inserted)
Byte 9	STOSCH: NNN: STS:	Mode selector at "Stop" Programming error; illegal operation for 101U Programmable "Stop"
Byte 10	NAU: ZYK: BAU:	Power failure Scan time exceeded Battery low
Byte 12	OR: VKE: ERAB:	Identifier bit for OR memory Result of logic operation Identifier bit for first scan
Byte 13	FKT:	Function 1=U(; 0=0(

Interrupt condition code word: Provides indication of reason for PC stopping and important pointers for troubleshooting

Nesting depth: Binary/decimal display of nesting depth (1...6)

STEP address counter: Indicates the address at which the program has aborted (1400H...1600H)

Accu 2/accu 1: Indicates the pattern of the second-last/last load operation.

## 4.3 Changing the backup battery

The lithium battery has a support time of at least three years.

Flag (internal relay) F 63.6 is set if the voltage drops below the level required for battery backup. The user program can thus respond accordingly (see also Programming Instructions, Section 3.2).

The backup battery can be changed with the PC in the "Run" state, proceeding as follows:

- Remove the cover of the battery compartment
- Take out the old battery
- Insert the new battery (noting polarity)
- Replace the battery compartment cover
- Exhausted lithium batteries are not rechargeable and must be disposed of properly (i.e. not simply thrown into a trash can).

Only the lithium battery in the list of spare parts may be used.

## 4.4 Interface assignments

Memory submodule interface

a	b	c	
V <sub>CC</sub>	M	AD12	1
AD2	AD1	AD0	2
AD5	AD4	AD3	3
AD8	AD7	AD6	4
AD11	AD10	AD9	5
$\overline{RD}$			6
		$\overline{PGM4}/\overline{WR}$	7
			8
			9
D2	D1	D0	10
D5	D4	D3	11
	D7	D6	12
	$\overline{CS1}$	$\overline{CS1}$	13
		$\overline{CS2}$	14
K4		V <sub>pp</sub>	15
K5	$\overline{RD}$	V <sub>pp</sub>	16

Fig. 23: Assignment of interface signals to the memory submodule

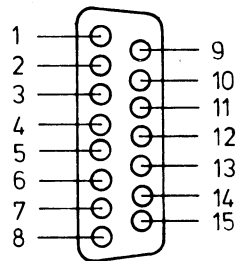

- 1 Shielding/earth, external
- 2 Rec-
- 3 V<sub>PU</sub> +5.2V
- 4 -
- 5 Zero volt reference potential, internal
- 6 Driver+
- 7 Driver-
- 8 Shielding/earth, external
- 9 Rec+
- 10 -
- 11 T/20mA- (current source/transmitter)
- 12 Zero V reference potential internal
- 13 R/20mA- (current source/receiver)
- 14 V<sub>PU</sub> +5.2V
- 15 Zero V reference potential, internal

Fig. 24: Assignment of interface signals to the PG605U programmer

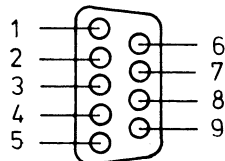

- 1 DIR
- 2 BASPIE
- 3 CSIO 0
- 4 P2.3
- 5 P2.1
- 6 CSIO 1
- 7 PROG
- 8 P2.2
- 9 P2.0

Fig. 25: Assignment of interface signals to the S5-101U expansion unit

# 5. Technical specifications

## 5.1 General data

Temperature range:

Low temperature limit 0°C (K) to  
 High temperature limit 55°C (V) DIN  
 Casing inlet air temp. ≤55°C 40 040  
 Storage temperature -40°C...+70°C

Humidity rating:

F to DIN 40 040  
 95% relative atmospheric humidity  
 at 25°C

RF interference suppression: A to VDE 0871

Degree of protection:

IP20 to DIN 40 050 (no protection against  
 water)

Creepage distances and clearances in  
 air to VDE 0160

Dimensions: 285 mm x 167 mm x 114 mm (WxHxD)  
 (II. 2 in. x 6.6 in. x 4.5 in.)

Vibration test to DIN 40 046, Part 8  
 and IEC 68, Part 2-6

Frequency range	Amplitude of acceleration	deflection
10 to 58 Hz	0,075 mm	---
over 58 up to 500 Hz	---	1 g

Impact test: 15g/11ms, trapezoidal to  
 DIN 40 046, Part 7

Weight: approx. 2.7 kg relay/triac  
 version  
 approx. 1.7 kg transistor  
 version

Model	Input voltage Tolerance, Frequency	Max. current consumption	Power dissipation at full load, typical	Internal power supply for sensors
CC, relay 6ES5 101-8UA13*	220 V AC/240 V AC -15 %, +10 % 48...63 Hz	260 mA	29 W	24 V DC/300 mA (20 V...30 V)
6ES5 101-8UB13		200 mA	22 W	
EU, relay 6ES5 101-8UC11		200 mA	23 W	
CC Triac 6ES5 101-8UC23	220 V AC/240 V AC -15 %, +10 % 48...63 Hz	180 mA	23 W	
EU Triac 6ES5 101-8UC21		150 mA	18 W	

\* Power supply fuse: 250 mA slow (6.3x32 mm)  
 All other fuses: 500 mA slow (6.3x32 mm)

CC-transistor 6ES5 101-8UA33	24 V DC rated 20 to 30 V range inclusive	0.9 A	22 W	Fuse 6.3 x 32 mm 2 A; slow
EU-transistor 6ES5 101-8UC31	3 V <sub>DD</sub> superimposed 0 Hz	0.6 A	14 W	Fuse 6.3 x 32 mm 0.5 A; slow

(only for 24 V version)  
 Floating operation: In floating operation,  
 all voltages connected must be extra-low  
 voltages in accordance with VDE 0100/5.73  
 §8c or equivalent. If not, the  $\pm$  terminal  
 must be connected to the PE conductor.

(only for 24 V version)  
 The CC and EU are protected electronically  
 against polarity reversal. If the voltage  
 source has electronic current limitation,  
 the dynamic overload factor of the supply  
 voltage must be  $\geq 5$  A and the load voltage  
 $\geq 20$  A to trigger the appliance fuses in  
 the case of a fault.



Model	Input voltage Tolerance, Frequency	Max. current consumption	Power dissipation at full load, typical	Internal power supply for sensors
CC-relay 6ES5 101-8UU13 6ES5 101-8UW13	115 V AC -15% +10% 48 ... 63 Hz	520 mA	29 W	24 V DC / 300 mA (20 V ... 30V)
EU-relay 6ES5 101-8UX11				

Power supply fuse: 1 A slow (6.3x32 mm) m)  
Sensor voltage fuse: 0,5 A slow (6.3x32 mm) )

## 5.2 CPU/memory submodule

Operations:

Binary operations  
Setting/resetting operations  
Load and transfer operations  
Timer and counter operations  
Comparison (relational) operations  
Arithmetic functions  
Digital logic  
Shift operations  
Jump operations

Processing time for one binary operation:  
approx. 70 µs

Internal program memory:

RAM for 1024 statements; supported  
for at least three years if a back-  
up battery is used

Memory submodules (plug-in):

a) EPROM submodule for 1024 statements  
Storage of program:  
on PG 615 (with adapter 984-2UA11)  
on PG 670 (with adapter 984-0UA11)  
on PG 675

Program erasure: UV lamp

b) EEPROM submodule for 1024 statements  
Storage and erasure of program also  
direct on the PC with all programmes

Addressing:

	CC	EU
40 inputs	(I0.0...I2.3)	(I3.0...I5.3)
24 outputs	(Q0.0...Q1.3)	(Q2.0...Q3.3)

512 flags or inter- (F0.0...F63.7)  
nal relays

256 retentive (F0.0...F31.7)\*

16 counters	(C0...C15)	Range 1...999
16 timers	(T0...T15)	Range 10 ms...9990s

\* with backup battery only

## 5.3 I/Os

In all models except the transistor  
version, the inputs are galvanically  
isolated from the internal power  
supply by means of optocouplers.

The signal statuses of the inputs are  
indicated by green LEDs; the LEDs are  
driven by the signal voltage of the  
inputs.

CC (relay version) 6ES5 101-8UA13, 6ES5 101-8UU13  
EU (relay version) 6ES5 101-8UC11, 6ES5 101-8UX11

Number of inputs	Rated input voltage	Rated input voltage for		Nominal input current for "1" signal	Delay, typical		Maximum length of line (24 V DC and 220 V lines run separately)	Insulation	
		"0" signal	"1" signal		ON	OFF		for nominal voltage	tested at
20 floating	24 V DC 2)	-35V...+4.5V or input open	+13V...+35V	8.5 mA 1)	3 ms	6 ms	600 m	36 V DC	500 V AC

Number of outputs	Contact switching capacity	Service life in switching cycles	Maximum switching frequency	Diversity factor	for Insulation nominal voltage	tested at
12 relays Connected in pairs to common potential 3)	$I_{th2}:5A$ $I_e(AC11):1.5 A/250 V$ $I_e(DC11):0.5 A/30 V$ Pilot duty rating: B300, R300	$1,5 \times 10^6$ $2,0 \times 10^5$	10 Hz resist. 2 Hz induct.	100%	250 V AC	2.0 kV AC

- 1) Applies also to two-wire proximity switches (voltage: 22V...30V DC)
- 2) If an external power supply unit is used, a smoothing capacitor must be fitted
- 3) Card relays of type E V23027-B002-A402 (SIEMENS); leakage current of parallel varistor  $\leq 1mA$ .
- 4) To VDE 0660, Part 200

### CC (relay version) 6ES5 101-8UB13, 6ES5 101-8UW13

Number of inputs	Rated input voltage	Rated input voltage for		Nominal input current for "1" signal	Delay, typical		Maximum length of line (24 V DC and 220 V lines run separately)	Insulation	
		"0" signal	"1" signal		ON	OFF		for nominal voltage	tested at
10 floating	24 V DC 2)	-35V...+4.5V or input open	+13V...+35V	8.5 mA 1)	3 ms	6 ms	600 m	36 V DC	500 V AC

Number of outputs	Contact switching frequency	Service life in switching cycle	Maximum switching frequency	Diversity factor (numb. of outputs "on" simultaneity)	for Insulation nominal voltage	tested at
6 relays grouped in pairs 3)	$I_{th2}:5A$ $I_e(AC11):1.5 A/250 V$ $I_e(DC11):0.5 A/30 V$ Pilot duty rating: B300, R300	$1,5 \times 10^6$ $2,0 \times 10^5$	10 Hz resist. 2 Hz induct.	100%	250 V AC	2.0 kV AC

T009

- 1) Applies also to two-wire proximity switches (voltage: 22V...30 V DC)
- 2) If an external power supply unit is used, a smoothing capacitor must be fitted
- 3) Card relays of type E V23027-B002-A402 (SIEMENS); leakage current of parallel varistor 1mA.
- 4) To VDE 0660, Part 200

The signal statuses of the outputs are indicated by green LEDs connected in parallel with the excitation coils of the relays.

The relay contacts are fitted with varistors (maximum leakage current 1 mA)

### CC (Triac version) 6ES5 101-8UA23 EU (Triac version) 6ES5 101-8UC21

Number of inputs	Rated input voltage	Rated input voltage for		Nominal input current for "1" signal	Delay and switching frequency, typical		Maximum length of line (24 V DC and 220 V lines run separately)	Insulation	
		"0" signal	"1" signal		ON	OFF		for nominal voltage	tested at
16 float. groups of 8 connec.	220 V AC +20%	0...40 V AC or input open	159...264 V AC	typ. 20 mA 1)	8 ms	15 ms	300 m	250V AC	2.0 kV AC
					10 Hz				

Number of outputs	Output current for "1" signal and at 264 V AC	Leakage current for "0" signal	Maximum switching frequency	Diversity factor	for Insulation nominal voltage	tested at
8 groups of four connected to common potential and with 10 A FF (fast) fuse	50mA...1.0A resist. 50mA...0.5A induct. Lamp load max. 60 W	max. 5 mA	10 Hz resist. 2 Hz induct. Lamp load 8 Hz	100%	250 V AC	1.5 kV AC

T009

- 1) Suitable for AC-proximity switches

The signal statuses of the outputs are indicated by green LEDs connected in parallel with the Triacs.

CC (transistor version) 6ES5 101-8UA33  
 EU (transistor version) 6ES5 101-8UC31

The inputs are galvanically connected via reference potential  $M_3$  with the input and the load voltage (outputs).

Green LEDs display the statuses of the inputs. The LEDs are powered by the signal voltage of the inputs.

Number of inputs	Rated input voltage	Input voltage for		Nominal input current for "1" signal	Delay, typical		Maximum length of line (24 V DC and 220 V lines run separately)	Insulation for nominal voltage
		"0" signal	"1" signal		ON	OFF		
20 non-floating	24 V DC 2)	-35V...+4.5V or input open	+13V...+35V	8.5 mA 1)	3 ms	6 ms	600 m	None - non-floating

- 1) Applies also to two-wire proximity switch)  
 (voltage: 22 V...30 V DC)  
 2) If an external power supply unit is used, a smoothing capacitor must be fitted

The outputs are connected galvanically via reference potential  $M_1$  and  $M_2$  with the line input and the sensor voltage. The statuses of the inputs are displayed by green LEDs switched in parallel to the outputs.

The LEDs are powered by the load voltage of the outputs. Load voltage range  $V_L = 20 \text{ V to } 30 \text{ V DC } 0 \text{ Hz inclusive of } 3 V_{pp}$  superimposed AC voltage.

Number of outputs	Output current at "1" signal and $V_L$	Residual current at "0" signal	Max. switching frequency	Diversity factor (number) outputs "on" simultaneity	Max. lead length
12 non-floating, connected in groups of 6 to common potential and 10 A superfast fuse	Signal level: $V_L - 1.5 \text{ V}$ Max. 1.0 A to $T_u \leq +40^\circ\text{C}$ Max. 0.5 A to $T_u \leq +55^\circ\text{C}$ Lamp load 5W to $T_u \leq 55^\circ\text{C}$ 9W to $T_u \leq 40^\circ\text{C}$ with $I_{EN} = 10 \times I_{Rated}$ Inductive load: 8 W to $T_u \leq +55^\circ\text{C}$	Max. 1mA	100 Hz resistive without allowing for cycle time 2 Hz inductive 8 Hz lamp load	100 %	100 m

Limitation of voltage induced on circuit interruption at  $V_L \leq 30 \text{ V DC}$ :  $\leq - 2.5 \text{ V}$

Short-circuit protection: electronic

- all outputs current-limited
  - constant short-circuit permissible only for one output at  $T_u \leq +30^\circ\text{C}$
- Max. lead resistance 1.5 Ohm

## 6. Spare parts and accessories

SPARE PARTS	Order No.
101U programmable controller, relay version (20E/12A)*	6ES5 101-8UA13
101U programmable controller, relay version (10E/6A)*	6ES5 101-8UB13
101U programmable controller, relay version (20E/12A)*	6ES5 101-8UU13
101U programmable controller, relay version (10E/6A)*	6ES5 101-8UW13
101U programmable controller, Triac version (10E/6A)*	6ES5 101-8UA23
101U programmable controller, transistor version (20E/12A)*	6ES5 101-8UA33
101U expansion unit, relay version (20E/12A)	6ES5 101-8UC11
101U expansion unit, relay version (20E/(12A)	6ES5 101-8UX11
101U expansion unit, Triac version (16E/8A)	6ES5 101-8UC21
101U expansion unit, transistor version (20E/12A)* 375 memory submodule with	6ES5 101-8UC31
EPROM for 1K statements EEPROM for 1K statements (5 V type)	6ES5 375-OLA15 6ES5 375-OLC11
984 U adapter ** PG670 programmer adapter for the memory submodules of the U-type PCs	6ES5 984-0UA11
UV erasing facility **	6ES5 985-0AA11
S5-101 simulator (for the S5-101 with 24 V inputs) ***	6ES5 788-0LB11
Lithium battery (for RAM backup)	6ES5 980-0AE11
G-type fuse-link 6.3 x 32 mm 250 mA (slow) (10 pcs.) 500 mA (slow) (10 pcs.) 10 AF (fast) (10 pcs.) 1 A (slow) (10 pcs.) 2 A (slow) (10 pcs.)	6ES5 980-3BA11 6ES5 980-3BA21 6ES5 980-3BC41 6ES5 980-3BA31 6ES5 980-3BA71
731 interconnecting cable (l=3, 2 m) * for connecting up the PG670/PG675 programmers to the 101U PC	6ES5 731-1BD20
PG605U programmer with	
German labelling	6ES5 605-0UA11
English labelling	6ES5 605-0UB11
French labelling	6ES5 605-0UC11
Carrying case for the PG 605U programmer PG 615 programmer, German labelling (without Operating system submodule)	6ES5 986-0LA11 6ES5 615-0UA11
Operating system submodule for PG 615 programmer German	6ES5 815-0UA11
English	6ES5 815-0UB11
French	6ES5 815-0UC11
101U PC manual	
German	6ES5 998-0UC13
English	6ES5 998-0UC23
French	6ES5 998-0UC33

\* E = Inputs  
A = Outputs

Obtainable from EWA

Exceptions::

\*\* Obtainable from GWK

\*\*\* Obtainable from Werkstatt Fürth