

SIEMENS

SIMATIC

S7-300 CPU 31xC and CPU 31x: Installation

Operating Instructions

Preface

Guide to the S7-300
documentation 1

Installation Sequence 2

S7-300 components 3

Configuring 4

Installing 5

Wiring 6

Addressing 7

Commissioning 8

Maintenance 9

Debugging functions,
diagnostics and
troubleshooting 10

General technical
specifications 11

Appendix A

This manual is part of the documentation package
with order number:
6ES7398-8FA10-8BA0

03/2011

A5E00105492-12

Legal information

Warning notice system

This manual contains notices you have to observe in order to ensure your personal safety, as well as to prevent damage to property. The notices referring to your personal safety are highlighted in the manual by a safety alert symbol, notices referring only to property damage have no safety alert symbol. These notices shown below are graded according to the degree of danger.

⚠ DANGER
indicates that death or severe personal injury will result if proper precautions are not taken.
⚠ WARNING
indicates that death or severe personal injury may result if proper precautions are not taken.
⚠ CAUTION
with a safety alert symbol, indicates that minor personal injury can result if proper precautions are not taken.
CAUTION
without a safety alert symbol, indicates that property damage can result if proper precautions are not taken.
NOTICE
indicates that an unintended result or situation can occur if the corresponding information is not taken into account.

If more than one degree of danger is present, the warning notice representing the highest degree of danger will be used. A notice warning of injury to persons with a safety alert symbol may also include a warning relating to property damage.

Qualified Personnel

The product/system described in this documentation may be operated only by **personnel qualified** for the specific task in accordance with the relevant documentation for the specific task, in particular its warning notices and safety instructions. Qualified personnel are those who, based on their training and experience, are capable of identifying risks and avoiding potential hazards when working with these products/systems.

Proper use of Siemens products

Note the following:

⚠ WARNING
Siemens products may only be used for the applications described in the catalog and in the relevant technical documentation. If products and components from other manufacturers are used, these must be recommended or approved by Siemens. Proper transport, storage, installation, assembly, commissioning, operation and maintenance are required to ensure that the products operate safely and without any problems. The permissible ambient conditions must be adhered to. The information in the relevant documentation must be observed.

Trademarks

All names identified by ® are registered trademarks of the Siemens AG. The remaining trademarks in this publication may be trademarks whose use by third parties for their own purposes could violate the rights of the owner.

Disclaimer of Liability

We have reviewed the contents of this publication to ensure consistency with the hardware and software described. Since variance cannot be precluded entirely, we cannot guarantee full consistency. However, the information in this publication is reviewed regularly and any necessary corrections are included in subsequent editions.

(A)

가

Preface

Purpose of this manual

This manual contains essential information about the following:

- Installation
- Communication
- Memory concept
- Cycle and response times
- Technical specifications of the CPUs.

Basic knowledge required

- In order to understand this manual, you require a general knowledge of automation engineering.
- You require knowledge of STEP 7 basic software.

Scope

The name CPU 31xC summarizes all compact CPUs, as table below shows:

CPU	Convention: CPU designations:	Order number	As of firmware version
CPU 312C	CPU 31xC	6ES7312-5BF04-0AB0	V3.3
CPU 313C		6ES7313-5BG04-0AB0	V3.3
CPU 313C-2 PtP		6ES7313-6BG04-0AB0	V3.3
CPU 313C-2 DP		6ES7313-6CG04-0AB0	V3.3
CPU 314C-2 PtP		6ES7314-6BH04-0AB0	V3.3
CPU 314C-2 DP		6ES7314-6CH04-0AB0	V3.3
CPU 314C-2 PN/DP		6ES7314-6EH04-0AB0	V3.3

The name CPU 31x summarizes all standard CPUs, as table below shows:

CPU	Convention: CPU designations:	Order number	As of firmware version
CPU 312	CPU 31x	6ES7312-1AE14-0AB0	V3.3
CPU 314		6ES7314-1AG14-0AB0	V3.3
CPU 315-2 DP		6ES7315-2AH14-0AB0	V3.3
CPU 315-2 PN/DP		6ES7315-2EH14-0AB0	V3.2
CPU 317-2 DP		6ES7317-2AK14-0AB0	V3.3
CPU 317-2 PN/DP		6ES7317-2EK14-0AB0	V3.2
CPU 319-3 PN/DP		6ES7318-3EL01-0AB0	V3.2

All CPUs with PROFINET properties are grouped under the designation CPU 31x PN/DP, as the following table shows:

CPU	Convention: CPU designations:	Order number	As of firmware version
CPU 314C-2 PN/DP	CPU 31x PN/DP	6ES7314-6EH04-0AB0	V3.3
CPU 315-2 PN/DP		6ES7315-2EH14-0AB0	V3.2
CPU 317-2 PN/DP		6ES7317-2EK14-0AB0	V3.2
CPU 319-3 PN/DP		6ES7318-3EL01-0AB0	V3.2

Note

A description of the special features of the failsafe CPUs of the S7 product range is available in the product information at the following Internet address

(<http://support.automation.siemens.com/WW/view/en/11669702/133300>).

Note

We reserve the right to include a product Information containing the latest information on new modules or modules of a more recent version.

Changes in comparison to the previous version

The following table contains changes from the previous versions of the following documentation from the S7-300 documentation package:

- Technical specifications manual, version 06/2010
- Operating instructions for installation, version 06/2010

The CPU- 314C-2 PN/DP has been added in delivery stage V3.3. It has the same functionalities as the CPU 314C-2 DP and also has PROFINET functionalities such as those of the CPU 315-2 PN/DP.

In delivery stage V3.3, the functionality and performance of all C-CPU and the CPU 317-2 DP were improved compared to their predecessor versions.

Additional information was taken from the chapter "Information on converting to a CPU 31xC or CPU 31x". If you required more information, however, please refer to the FAQs () on the Internet.

CPU	312	312C	313C	313C-2 DP	313C-2 PtP	314	314C-2 DP	314C-2 PtP	315-2 DP	317-2 DP
Encryption of blocks using S7-Block Privacy	X	X	X	X	X	X	X	X	X	X
Integration of a maintenance LED	X ^{1,2}	X ²	X ²	X ²	X ²	X ^{1,2}	X ²	X ²	X ^{1,2}	X ²
Configurable increase of control and monitoring performance	-	-	-	-	-	-	-	-	X	X
Improved operational limits for PT100 Analog input	-	-	X	-	-	-	X	X	-	-
Data set routing	-	-	-	X	-	-	X	-	X ¹	X
Configurable process image	X ¹	X	X	X	X	X ¹	X	X	X ¹	X
Expansion of the block number range	X ¹	X	X	X	X	X ¹	X	X	X ¹	X
Number of displayed diagnostic buffer entries can be configured in CPU RUN mode	X ¹	X	X	X	X	X ¹	X	X	X ¹	X
Reading out the service data	X ¹	X	X	X	X	X ¹	X	X	X ¹	X
Extension of SFC 12 with 2 new modes to trigger the OB 86 during enabling/disabling	-	-	-	X	-	-	X	-	X ¹	X
Copying of 512 bytes with SFC 81	X ¹	X	X	X	X	X ¹	X	X	X ¹	X

CPU	312	312C	313C	313C-2 DP	313C-2 PtP	314	314C-2 DP	314C-2 PtP	315-2 DP	317-2 DP
Increase										
Main memory	X ¹	X	X	X	X	X ¹	X	X	X ¹	X
Performance through shorter command processing times	X ¹	X	X	X	X	X ¹	X	X	X ¹	X
Status information that can be monitored by the status block, in STEP 7 V5.5 or higher	X ¹	X	X	X	X	X ¹	X	X	X ¹	X
Number of blocks that can be monitored by the status block (from 1 to 2)	X ¹	X	X	X	X	X ¹	X	X	X ¹	X
Number of breakpoints from 2 to 4	X ¹	X	X	X	X	X ¹	X	X	X ¹	X
Local data stack	X ¹	X	X	X	X	X ¹	X	X	X ¹	X
Number of block-related messages (Alarm_S) is uniformly limited to 300	X ¹	X	X	X	X	X ¹	X	X	X ¹	X
Number of the bit memories, timers and counters	X ¹	X	-	-	-	-	-	-	-	-
Standardization										
DB sizes: Max. 64 KB	X ^{1,3}	X	X	X	X	X ¹	X	X	X ¹	X ¹
Watchdog interrupts: OB 32 to OB 35	X ¹	X	X	X	X	X ¹	X	X	X ¹	X ¹
Global data communication of 8 GD circles	X ¹	X	X	X	X	X ¹	X	X	X ¹	X ¹
System function blocks for integrated technology functions:										
SFB 41 to 43	-	-	X ¹	X ¹	X ¹	-	X ¹	X ¹	-	-
SFB 44 and 46	-	-	-	-	-	-	X ¹	X ¹	-	-
SFB 47 to 49	-	X ¹	X ¹	X ¹	X ¹	-	X ¹	X ¹	-	-
SFB 60 to 62	-	-	-	-	X ¹	-	-	X ¹	-	-
SFB 63 to 65	-	-	-	-	-	-	-	X ¹	-	-
¹ This function was already made available to the CPU in an earlier version ² Available, but without function ³ Max. DB size 32 KB										

Standards and certifications

For information about standards and approvals, see the section "General technical specifications (Page 251)".

Recycling and disposal

Because they have ecologically compatible components, the devices described in this manual can be recycled. For environment-friendly recycling and disposal of your old equipment, contact a certified disposal facility for electronic scrap.

Service & Support on the Internet

In addition to our documentation, we offer a comprehensive knowledge base online on the Internet (<http://www.siemens.com/automation/service&support>).

There you will find:

- Our newsletter containing up-to-date information on your products
- The latest documents in the Siemens Service & Support (<http://www.siemens.com/automation/service&support>) search engine.
- A forum for global information exchange by users and specialists.
- Your local representative for automation and drives in our contact database
- Information about on-site services, repairs, spare parts, and lots more.
- Applications and tools for the optimized use of the SIMATIC S7. For example, Siemens also publishes DP and PN performance measurements on the Internet (<http://www.siemens.com/automation/pd>).

Table of contents

	Preface	3
1	Guide to the S7-300 documentation	15
1.1	Documentation classification	15
1.2	Guide to the S7-300 documentation	20
2	Installation Sequence	23
3	S7-300 components	25
3.1	Example of an S7-300 configuration.....	25
3.2	Overview of the most important S7-300 modules.....	26
4	Configuring	29
4.1	Overview	29
4.2	Basic configuration principles	29
4.3	Component dimensions	32
4.4	Specified clearances.....	34
4.5	Arrangement of modules on a single rack	35
4.6	Distribution of modules to several racks	36
4.7	Selection and installation of cabinets.....	39
4.8	Example: Selecting a cabinet.....	41
4.9	Electrical assembly, protective measures and grounding	43
4.9.1	Grounding concept and overall structure.....	43
4.9.2	Installing an S7-300 with grounded reference potential	44
4.9.3	Installing an S7-300 with ungrounded reference potential (not CPU 31xC).....	45
4.9.4	Isolated or non-isolated modules?	46
4.9.5	Grounding measures	49
4.9.6	Overview: Grounding	52
4.10	Selection of the load power supply	54
4.11	Planning subnets	56
4.11.1	Overview	56
4.11.2	Configuring MPI and PROFIBUS subnets	58
4.11.2.1	Overview	58
4.11.2.2	Basic information relating to MPI and PROFIBUS subnets.....	58
4.11.2.3	Multi-Point Interface (MPI)	61
4.11.2.4	PROFIBUS DP interface.....	62
4.11.2.5	Network components of MPI/DP and cable lengths	63
4.11.2.6	Cable lengths of MPI and PROFIBUS subnets	68

4.11.3	Configuring PROFINET subnets	73
4.11.3.1	Overview	73
4.11.3.2	PROFINET devices	73
4.11.3.3	Integration of fieldbuses into PROFINET	77
4.11.3.4	PROFINET IO and PROFINET CBA	78
4.11.3.5	PROFINET cable lengths and network expansion	85
4.11.3.6	Connectors and other components for Ethernet	88
4.11.3.7	Example of a PROFINET subnet	88
4.11.3.8	PROFINET IO System	90
4.11.4	Routed network transitions	92
4.11.5	Point-to-point (PtP)	94
4.11.6	Actuator/sensor interface (ASI)	94
5	Installing	95
5.1	Installing an S7-300	95
5.2	Installing the mounting rail	97
5.3	Installing modules on the mounting rail	100
5.4	Labeling modules	102
6	Wiring	105
6.1	Requirements for wiring the S7-300	105
6.2	Bonding the Protective Conductor to the Mounting Rail	107
6.3	Adjusting the power supply module to local mains voltage	108
6.4	Wiring the power supply module and the CPU	109
6.5	Wiring front connectors	111
6.6	Plugging the front connectors into modules	114
6.7	Wiring I/O modules and compact CPUs with Fast Connect	115
6.8	Labeling the module I/Os	120
6.9	Terminating shielded cables on the shield connection element	121
6.10	Wiring bus connectors	124
6.10.1	MPI/PROFIBUS bus connector	124
6.10.2	Setting up the terminating resistor on the PROFIBUS connector	125
6.10.3	PROFINET bus connector	126
7	Addressing	127
7.1	Slot-specific addressing of modules	127
7.2	User-specific addressing of modules	129
7.2.1	User-specific addressing of modules	129
7.2.2	Addressing digital modules	130
7.2.3	Addressing analog modules	131
7.2.4	Addressing the integrated I/Os of CPU 31xC	132
7.3	Addressing on PROFIBUS DP	135
7.4	Addressing PROFINET IO	136
7.5	Assigning IP address parameters and the device name	137

8	Commissioning	141
8.1	Overview	141
8.2	Commissioning procedure	141
8.2.1	Procedure: Commissioning the hardware	141
8.2.2	Procedure: Software commissioning	143
8.3	Commissioning check list.....	145
8.4	Commissioning the Modules.....	147
8.4.1	Inserting/replacing a Micro Memory Card	147
8.4.2	Initial power on	149
8.4.3	CPU memory reset by means of mode selector switch	150
8.4.4	Formatting the Micro Memory Card	154
8.4.5	Connecting the programming device (PG)	155
8.4.5.1	Connect PG/PC to the integrated PROFINET interface of the CPU 31x PN/DP	155
8.4.5.2	Connecting the PG to a node.....	156
8.4.5.3	Connecting the PG to several nodes	157
8.4.5.4	Using the PG for commissioning or maintenance.....	158
8.4.5.5	Connecting a PG to ungrounded MPI nodes (not CPU 31xC)	160
8.4.6	Starting SIMATIC Manager.....	161
8.4.7	Monitoring and modifying inputs and outputs	161
8.5	Commissioning PROFIBUS DP	166
8.5.1	Commissioning the PROFIBUS DP network	166
8.5.2	Commissioning the CPU as DP master	168
8.5.3	Commissioning the CPU as DP Slave	172
8.5.4	Direct data exchange	178
8.6	Commissioning PROFINET IO	180
8.6.1	Requirements.....	180
8.6.2	Commissioning the PROFINET IO system	181
8.6.3	Configuring the PROFINET IO system	182
9	Maintenance	189
9.1	Overview	189
9.2	Backing up firmware on a SIMATIC Micro Memory Card.....	189
9.3	Updating the firmware.....	191
9.3.1	Firmware update using a Micro Memory Card.....	192
9.3.2	Updating the firmware online (via networks).....	193
9.4	Backup of project data to a Micro Memory Card	195
9.5	Resetting to the Delivery State	197
9.6	Module installation/removal	198
9.7	Digital output module: Changing fuses	202
10	Debugging functions, diagnostics and troubleshooting	205
10.1	Overview	205
10.2	Reading out service data	205
10.3	Identification and maintenance data of the CPU	206
10.4	Overview: Debugging functions	208

10.5	Overview: Diagnostics.....	212
10.6	Diagnostics functions available in STEP 7.....	216
10.7	Network infrastructure diagnostics (SNMP).....	217
10.8	Diagnostics using status and error LEDs.....	219
10.8.1	Introduction	219
10.8.2	Status and error displays of all CPUs	219
10.8.3	Evaluating the SF LED in the case of software errors.....	221
10.8.4	Evaluating the SF LED in the case of hardware errors.....	222
10.8.5	Status and error indicators: CPUs with DP interface.....	224
10.8.6	Status and error indicators: CPUs with PROFINET interface for the S7-300.....	226
10.8.7	Status and error indicators: PROFINET IO Devices.....	229
10.9	Diagnostics of DP CPUs	230
10.9.1	Diagnostics of DP CPUs operating as DP Master	230
10.9.2	Reading out slave diagnostic data	233
10.9.3	Interrupts on the DP Master	238
10.9.4	Structure of the slave diagnostics when the CPU is operated as I-slave	239
10.10	Diagnostics of PROFINET CPUs.....	247
10.10.1	Diagnostics options of PROFINET IO.....	247
10.10.2	Maintenance.....	249
11	General technical specifications	251
11.1	Standards and certifications.....	251
11.2	Electromagnetic compatibility	255
11.3	Transportation and storage conditions for modules.....	257
11.4	Mechanical and climatic environmental conditions for S7-300 operation.....	258
11.5	Specification of dielectric tests, protection class, degree of protection, and rated voltage of S7-300.....	260
11.6	Rated voltages of S7-300.....	260
A	Appendix.....	261
A.1	General rules and regulations for S7-300 operation.....	261
A.2	Protection against electromagnetic interference.....	263
A.2.1	Basic Points for EMC-compliant system installations	263
A.2.2	Five basic rules for securing EMC	265
A.2.2.1	1. Basic rule for ensuring EMC	265
A.2.2.2	2. Basic rule for ensuring EMC	265
A.2.2.3	3. Basic rule for ensuring EMC	266
A.2.2.4	4. Basic rule for ensuring EMC	266
A.2.2.5	5. Basic rule for ensuring EMC	267
A.2.3	EMC-compliant installation of automation systems	267
A.2.4	Examples of an EMC-compliant installation: Cabinet configuration	269
A.2.5	Examples of an EMC-compliant installation: Wall mounting.....	270
A.2.6	Cable shielding.....	272
A.2.7	Equipotential bonding.....	273
A.2.8	Cable routing inside buildings	275
A.2.9	Outdoor routing of cables.....	277

A.3	Lightning and surge voltage protection.....	278
A.3.1	Overview	278
A.3.2	Lightning protection zone concept	279
A.3.3	Rules for the interface between the lightning protection zones 0 and 1	281
A.3.4	Rules for the interface between the lightning protection zones 1 and 2	284
A.3.5	Rules for the interface between the lightning protection zones 2 and 3	286
A.3.6	Example: Surge protection circuit for networked S7-300 CPUs	288
A.3.7	How to protect digital output modules against overvoltages caused by inductance	290
A.4	Functional safety of electronic control equipment.....	292
	Glossary	295
	Index.....	323

Guide to the S7-300 documentation

1.1 Documentation classification

Documentation classification

The documentation listed below is part of the S7-300 documentation package.

You can also find this on the Internet and the corresponding entry ID.

Name of the documentation	Description
Manual CPU 31xC and CPU 31x: Technical specifications Entry ID: 12996906 http://support.automation.siemens.com/WW/view/en/12996906	Description of: <ul style="list-style-type: none"> • Operator controls and indicators • Communication • Memory concept • Cycle and response times • Technical specifications
Operating Instructions CPU 31xC and CPU 31x: Installation Entry ID: 13008499 http://support.automation.siemens.com/WW/view/en/13008499	Description of: <ul style="list-style-type: none"> • Configuring • Installing • Wiring • Addressing • Commissioning • Maintenance and the test functions • Diagnostics and troubleshooting
Operating Instructions CPU 31xC: Technological functions incl. CD Entry ID: 12429336 http://support.automation.siemens.com/WW/view/en/12429336	Description of the specific technological functions: <ul style="list-style-type: none"> • Positioning • Counting • Point-to-point connection • Rules The CD contains examples of the technological functions.

Name of the documentation	Description
<p>Manual S7-300 Automation System: Module data Entry ID: 8859629 http://support.automation.siemens.com/WW/view/en/8859629</p>	<p>Descriptions and technical specifications of the following modules:</p> <ul style="list-style-type: none"> • Signal modules • Power supplies • Interface modules
<p>List Manual Instruction List of the S7-300 CPUs and ET- 200 CPUs Entry ID: 31977679 http://support.automation.siemens.com/WW/view/en/31977679</p>	<ul style="list-style-type: none"> • List of the instruction set of the CPUs and their execution times. • List of the executable blocks (OBs/SFCs/SFBs) and their execution times.

Additional information

You also require information from the following descriptions:

Name of the documentation	Description
<p>Getting Started S7-300 Automation System: Getting Started CPU 31x: Commissioning Entry ID: 15390497 http://support.automation.siemens.com/WW/view/en/15390497</p>	<p>Description of examples showing the various commissioning phases leading to a functional application.</p>
<p>Getting Started S7-300 Automation System: Getting Started CPU 31xC: Commissioning Entry ID: 48077635 http://support.automation.siemens.com/WW/view/en/48077635</p>	<p>Description of examples showing the various commissioning phases leading to a functional application.</p>
<p>Getting Started First steps in commissioning CPU 31xC: Positioning with analog output Entry ID: 48070939 http://support.automation.siemens.com/WW/view/en/48070939</p>	<p>Description of examples showing the various commissioning phases leading to a functional application.</p>
<p>Getting Started First steps in commissioning CPU 31xC: Positioning with digital output Entry ID: 48077520 http://support.automation.siemens.com/WW/view/en/48077520</p>	<p>Description of examples showing the various commissioning phases leading to a functional application.</p>

Name of the documentation	Description
<p>Getting Started First steps in commissioning CPU 31xC: Counting Entry ID: 48064324 http://support.automation.siemens.com/WW/view/en/48064324</p>	<p>Description of examples showing the various commissioning phases leading to a functional application.</p>
<p>Getting Started First steps in commissioning CPU 31xC: Point-to-point connection Entry ID: 48064280 http://support.automation.siemens.com/WW/view/en/48064280</p>	<p>Description of examples showing the various commissioning phases leading to a functional application.</p>
<p>Getting Started First steps in commissioning CPU 31xC: Rules Entry ID: 48077500 http://support.automation.siemens.com/WW/view/en/48077500</p>	<p>Description of examples showing the various commissioning phases leading to a functional application.</p>
<p>Getting Started CPU315-2 PN/DP, 317-2 PN/DP, 319-3 PN/DP: Configuring the PROFINET interface Entry ID: 48080216 http://support.automation.siemens.com/WW/view/en/48080216</p>	<p>Description of examples showing the various commissioning phases leading to a functional application.</p>
<p>Getting Started CPU 317-2 PN/DP: Configuring an ET 200S as PROFINET IO device Entry ID: 19290251 http://support.automation.siemens.com/WW/view/en/19290251</p>	<p>Description of examples showing the various commissioning phases leading to a functional application.</p>
<p>Reference Manual System and standard functions for S7-300/400, volume 1/2 Entry ID: 1214574 http://support.automation.siemens.com/WW/view/en/1214574</p>	<p>Overview of objects included in the operating systems for S7-300 and S7-400 CPUs:</p> <ul style="list-style-type: none"> • OBs • SFCs • SFBs • IEC functions • Diagnostics data • System status list (SSL) • Events <p>This manual is part of the STEP 7 reference information. You can also find the description in the STEP 7 Online Help.</p>

1.1 Documentation classification

Name of the documentation	Description
<p>Manual Programming with STEP 7 Entry ID: 18652056 http://support.automation.siemens.com/WW/view/en/18652056</p>	<p>This manual provides a complete overview of programming with the STEP 7 Standard Package. This manual is part of the STEP 7 Standard Package basic information. You can also find a description in the STEP 7 Online Help.</p>
<p>System Manual PROFINET System Description Entry ID: 19292127 http://support.automation.siemens.com/WW/view/en/19292127</p>	<p>Basic description of PROFINET:</p> <ul style="list-style-type: none"> • Network components • Data exchange and communication • PROFINET IO • Component Based Automation • Application example of PROFINET IO and Component Based Automation
<p>Programming manual From PROFIBUS DP to PROFINET IO Entry ID: 19289930 http://support.automation.siemens.com/WW/view/en/19289930</p>	<p>Guideline for the migration from PROFIBUS DP to PROFINET I/O.</p>
<p>Manual SIMATIC NET: Twisted Pair and Fiber-Optic Networks Entry ID: 8763736 http://support.automation.siemens.com/WW/view/en/8763736</p>	<p>Description of:</p> <ul style="list-style-type: none"> • Industrial Ethernet networks • Network configuration • Components • Guidelines for setting up networked automation systems in buildings, etc.
<p>Configuring Manual Configure SIMATIC iMap plants Entry ID: 22762190 http://support.automation.siemens.com/WW/view/en/22762190</p>	<p>Description of the SIMATIC iMap configuration software</p>
<p>Configuring Manual SIMATIC iMap STEP 7 AddOn, create PROFINET components Entry ID: 22762278 http://support.automation.siemens.com/WW/view/en/22762278</p>	<p>Descriptions and instructions for creating PROFINET components with STEP 7 and for using SIMATIC devices in Component Based Automation</p>

Name of the documentation	Description
Function Manual Isochronous mode Entry ID: 15218045 http://support.automation.siemens.com/WW/view/en/15218045	Description of the system property "Isochronous mode"
System Manual Communication with SIMATIC Entry ID: 1254686 http://support.automation.siemens.com/WW/view/en/1254686	Description of: <ul style="list-style-type: none"> • Basics • Services • Networks • Communication functions • Connecting PGs/OPs • Engineering and configuring in STEP 7

Service & support on the Internet

Information on the following topics can be found on the Internet
<http://www.siemens.com/automation/service>:

- Contacts for SIMATIC (<http://www.siemens.com/automation/partner>)
- Contacts for SIMATIC NET (<http://www.siemens.com/simatic-net>)
- Training (<http://www.sitrain.com>)

1.2 Guide to the S7-300 documentation

Overview

The following tables contain a guide through the S7-300 documentation.

Ambient influence on the automation system

Information about ...	is available in the manual ...	In Section ...
What provisions do I have to make for automation system installation space?	<ul style="list-style-type: none"> CPU 31xC and CPU 31x: Installation 	Configuring – Component dimensions Mounting – Installing the mounting rail
How do environmental conditions influence the automation system?	<ul style="list-style-type: none"> CPU 31xC and CPU 31x: Installation 	Appendix

Isolation

Information about ...	is available in the manual ...	In Section ...
Which modules can I use if electrical isolation is required between sensors/actuators?	<ul style="list-style-type: none"> CPU 31xC and CPU 31x: Installation Module data 	Configuring – Electrical assembly, protective measures and grounding
Under what conditions do I have to isolate the modules electrically? How do I wire that?	<ul style="list-style-type: none"> CPU 31xC and CPU 31x: Installation 	Configuring – Electrical assembly, protective measures and grounding Wiring
Under which conditions do I have to isolate stations electrically? How do I wire that?	<ul style="list-style-type: none"> CPU 31xC and CPU 31x: Installation 	Configuring – Configuring subnets

Communication between sensors/actuators and the PLC

Information about ...	is available in the manual ...	In Section ...
Which module is suitable for my sensor/actuator?	<ul style="list-style-type: none"> CPU 31xC and CPU 31x: Technical specifications For your signal module 	Technical specifications
How many sensors/actuators can I connect to the module?	<ul style="list-style-type: none"> CPU 31xC and CPU 31x: Technical specifications For your signal module 	Technical specifications
How do I connect my sensors/actuators to the automation system, using the front connector?	<ul style="list-style-type: none"> CPU 31xC and CPU 31x: Installation 	Wiring – Wiring the front connector

Information about ...	is available in the manual ...	In Section ...
When do I need expansion modules (EM) and how do I connect them?	<ul style="list-style-type: none"> CPU 31xC and CPU 31x: Installation 	Configuring – Distribution of modules across multiple racks
How do I mount modules on racks / mounting rails?	<ul style="list-style-type: none"> CPU 31xC and CPU 31x: Installation 	Assembly – Installing modules on the mounting rail

The use of local and distributed IOs

Information about ...	is available in the manual ...	In Section ...
Which range of modules do I want to use?	<ul style="list-style-type: none"> Module data (for centralized IOs/ expansion devices) of the respective peripheral (for distributed IOs/ PROFIBUS DP) 	–

Configuration consisting of the central controller and expansion units

Information about ...	is available in the manual ...	In Section ...
Which rack / mounting rail is most suitable for my application?	<ul style="list-style-type: none"> CPU 31xC and CPU 31x: Installation 	Configuring
Which interface modules (IM) do I need to connect the expansion units to the central controller?	<ul style="list-style-type: none"> CPU 31xC and CPU 31x: Installation 	Configuring – Distribution of modules across multiple racks
What is the right power supply (PS) for my application?	<ul style="list-style-type: none"> CPU 31xC and CPU 31x: Installation 	Configuring

CPU performance

Information about ...	is available in the manual ...	In Section ...
Which memory concept is best suited to my application?	<ul style="list-style-type: none"> CPU 31xC and CPU 31x: Technical specifications 	Memory concept
How do I insert and remove Micro Memory Cards?	<ul style="list-style-type: none"> CPU 31xC and CPU 31x: Installation 	Commissioning – Commissioning modules – Removing / inserting a Micro Memory Card (MMC)
Which CPU meets my demands on performance?	<ul style="list-style-type: none"> S7-300 instruction list: CPU 31xC and CPU 31x 	–
Length of the CPU response / execution times	<ul style="list-style-type: none"> CPU 31xC and CPU 31x: Technical specifications 	–
Which technological functions are implemented?	<ul style="list-style-type: none"> Technological functions 	–
How can I use these technological functions?	<ul style="list-style-type: none"> Technological functions 	–

Communication

Information about ...	is available in the manual ...	In Section ...
Which principles do I have to take into account?	<ul style="list-style-type: none"> CPU 31xC and CPU 31x: Technical specifications Communication with SIMATIC PROFINET System Description 	Communication
Options and resources of the CPU	<ul style="list-style-type: none"> CPU 31xC and CPU 31x: Technical specifications 	Technical specifications
How to use communication processors (CPs) to optimize communication	<ul style="list-style-type: none"> CP Manual 	–
Which type of communication network is best suited to my application?	<ul style="list-style-type: none"> CPU 31xC and CPU 31x: Installation 	Configuring – Configuring subnets
How do I network the various components?	<ul style="list-style-type: none"> CPU 31xC and CPU 31x: Installation 	Configuring – Configuring subnets
What to take into account when configuring PROFINET networks	<ul style="list-style-type: none"> SIMATIC NET, twisted-pair and fiber-optic networks (6GK1970-1BA10-0AA0) 	Network configuration
	<ul style="list-style-type: none"> PROFINET System Description 	Installation and commissioning

Software

Information about ...	is available in the manual ...	In Section ...
Software requirements of my S7-300 system	<ul style="list-style-type: none"> CPU 31xC and CPU 31x: Technical specifications 	Technical specifications

Supplementary features

Information about ...	is available in ...
How can I implement operation and monitoring functions? (Human Machine Interface)	The relevant manual: <ul style="list-style-type: none"> For text-based displays For Operator Panels For WinCC
How to integrate process control modules	<ul style="list-style-type: none"> Respective PCS7 manual
What options are offered by redundant and fail-safe systems?	<ul style="list-style-type: none"> S7-400H – Fault-Tolerant Systems Failsafe systems
Information to be observed when migrating from PROFIBUS DP to PROFINET IO	<ul style="list-style-type: none"> From PROFIBUS DP to PROFINET IO

Installation Sequence

We will start by showing you the sequence of steps you have to follow to install your system. Then we will go on to explain the basic rules that you should follow, and how you can modify an existing system.

Installation procedure

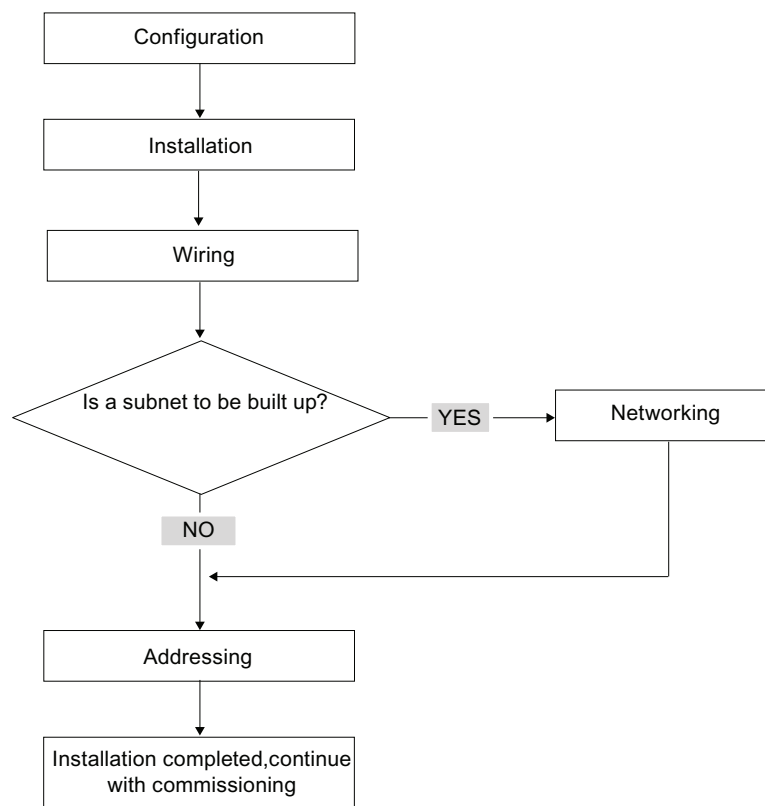

Basic rules for trouble-free operation of the S7 system

In view of the many and versatile applications, we can only provide basic rules for the electrical and mechanical installation in this section.

You have to at least keep to these basic rules in order to obtain a fully functional SIMATIC-S7 system.

Modifying the existing S7 system structure

To modify the configuration of an existing system, proceed as described earlier.

Note

When adding a new signal module, always refer to the relevant module information.

Reference

Also refer to the description of the various modules in the manual: *SIMATIC S7-300 Automation Systems, Module Data Manual*.

S7-300 components

3.1 Example of an S7-300 configuration

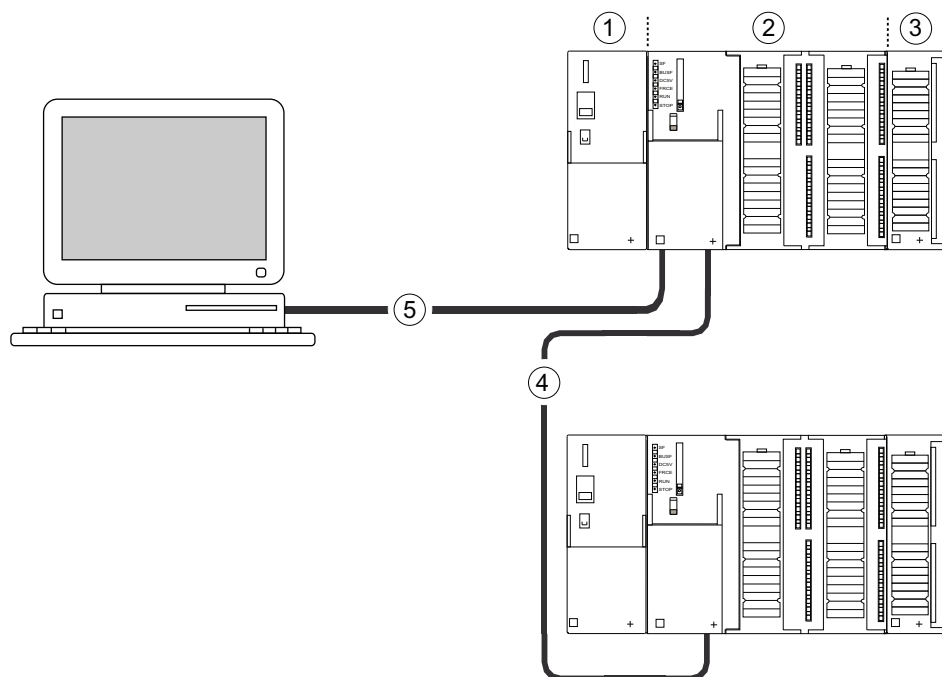

Number	Description
①	Power supply (PS) module
②	Central processing unit (CPU); the example in the diagram shows a CPU 31xC with integrated I/O.
③	Signal module (SM)
④	PROFIBUS bus cable
⑤	Cable for connecting a programming device (PG)

You use a programming device (PG) to program the S7300 PLC. Use the PG cable to interconnect the PG with the CPU.

To commission or program a CPU with PROFINET connection, you also have the choice to connect the programming device to the PROFINET port of the CPU via Ethernet cable.

Several S7-300 CPUs communicate with one another and with other SIMATIC S7 PLCs via the PROFIBUS cable. Several S7-300 are connected via the PROFIBUS bus cable.

3.2 Overview of the most important S7-300 modules

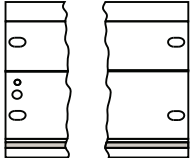
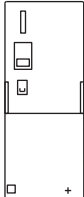
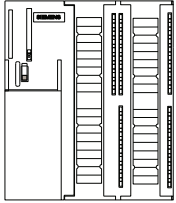
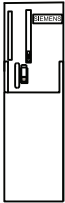
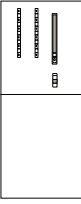

You can choose from a number of modules for installing and commissioning the S7-300. The most important modules and their functions are shown below.

Table 3- 1 S7-300 components:

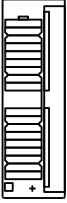
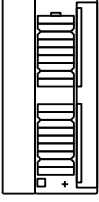
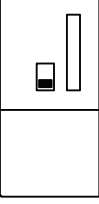
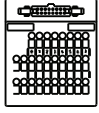
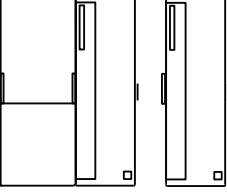
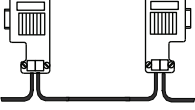
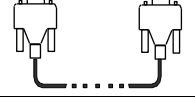
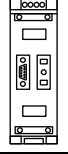
Component	Function	Illustration
Mounting rail Accessories: <ul style="list-style-type: none"> Shield connection element 	S7-300 racks	
Power supply (PS) module	The PS converts the line voltage (120/230 VAC) into a 24 VDC operating voltage, and supplies the S7-300 and its 24 VDC load circuits.	
CPU Accessories: <ul style="list-style-type: none"> Front connectors (CPU 31xC only) 	The CPU executes the user program, supplies 5 V to the S7-300 backplane bus, and communicates with other nodes of an MPI network via the MPI interface. Additional features of specific CPUs: <ul style="list-style-type: none"> DP master or DP slave on a PROFIBUS subnet Technological functions Point-to-point connection Ethernet communication via integrated PROFINET interface 	<div style="display: flex; flex-direction: column; align-items: center;"> <div style="display: flex; align-items: center; margin-bottom: 10px;">  <div style="margin-left: 10px;">A CPU 31xC, for example</div> </div> <div style="display: flex; align-items: center; margin-bottom: 10px;">  <div style="margin-left: 10px;">A CPU 312, 314, or 315-2 DP, for example</div> </div> <div style="display: flex; align-items: center;">  <div style="margin-left: 10px;">A CPU 317, for example</div> </div> </div>

Component	Function	Illustration
Signal modules (SM) <ul style="list-style-type: none"> • Digital input modules • Digital output modules • Digital input/output module • Analog input modules • Analog output modules • Analog I/O modules Accessories: <ul style="list-style-type: none"> • Front connectors 	The SM matches different process signal levels to the S7-300.	
Function modules (FM) Accessories: <ul style="list-style-type: none"> • Front connectors 	The FM performs time-critical and memory-intensive process signal processing tasks. Positioning or controlling, for example	
Communication processor (CP) Accessories: Connecting cable	The CP relieves the CPU of communication tasks. Example: CP 342-5 DP for connecting to PROFIBUS DP	
SIMATIC TOP connect Accessories: <ul style="list-style-type: none"> • Front connector module with ribbon cable terminals 	Wiring of digital modules	
Interface module (IM) Accessories: <ul style="list-style-type: none"> • Connecting cable 	The IM connects the various rows in an S7-300 with one another.	
PROFIBUS bus cable with bus connector	Connects the nodes of an MPI or PROFIBUS subnet with one another.	
PG cable	Connects a PG/PC to a CPU	
RS 485 repeater RS 485 Diagnostic Repeater	The repeater is used to amplify the signals and to couple segments of an MPI or PROFIBUS subnet.	

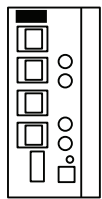
3.2 Overview of the most important S7-300 modules

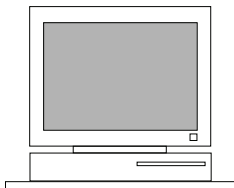
Component	Function	Illustration
Switch	A switch is used to interconnect the Ethernet nodes.	
Twisted-pair cables with RJ45 connectors.	Interconnects devices with Ethernet interface (a switch with a CPU 317-2 PN/DP, for example)	
Programming device (PG) or PC with the STEP 7 software package	You need a PG to configure, set parameters for, program and test your S7-300.	

Configuring

4.1 Overview

There, you can find all the necessary information

- for the mechanical configuration of an S7-300,
- for the electrical configuration of an S7-300,
- that has to be observed in networking.

Reference

For more detailed information, refer to

- the *Communication with SIMATIC* manual or
- the *SIMATIC NET twisted pair and fiber optic networks* manual (6GK1970-1BA10-0AA0)

4.2 Basic configuration principles

Important information for engineering

WARNING

Open equipment

S7-300 modules are open equipment. That is, the S7-300 must be installed in a cubicle, cabinet or electrical control room which can only be accessed using a key or tool. Only trained or authorized personnel are allowed access to such cubicles, cabinets or electrical operating rooms.

CAUTION

Operation of an S7-300 in plants or systems is defined by special set of rules and regulations, based on the relevant field of application. Observe the safety and accident prevention regulations for specific applications, for example, the machine protection directives. This chapter and the appendix *General rules and regulations on S7-300 operation* provide an overview of the most important rules you need to observe when integrating an S7-300 into a plant or a system.

Central unit (CU) and expansion module (EM)

An S7-300 PLC consists of a central unit (CU) and of one or multiple expansion modules.

The rack containing the CPU is the central unit (CU). Racks equipped with modules and connected to the CU form the expansion modules (EMs) of the system.

Use of an expansion module (EM)

You can use EMs if the CU runs out of slots for your application.

When using EMs, you might require additional power supply modules in addition to the extra racks and interface modules (IM). When using interface modules you must ensure compatibility of the partner stations.

Racks

The rack for your S7-300 is a mounting rail. You can use this rail to mount all modules of your S7-300 system.

4.3 Component dimensions

Length of the mounting rails

Table 4- 1 Mounting rails - Overview

Mounting rail length	Usable length for modules	Order number
160 mm	120 mm	6ES7390-1AB60-0AA0
482.6 mm	450 mm	6ES7390-1AE80-0AA0
530 mm	480 mm	6ES7390-1AF30-0AA0
830 mm	780 mm	6ES7390-1AJ30-0AA0
2000 mm	cut to length as required	6ES7390-1BC00-0AA0

In contrast to other rails, the 2 m mounting rail is not equipped with any fixing holes. These must be drilled, allowing optimal adaptation of the 2 m rail to your application.

Installation Dimensions of the Modules

Table 4- 2 Module width

Module	Width
Power supply module PS 307, 2 A	40 mm
Power supply module PS 307, 5 A	60 mm
Power supply module PS 307, 10 A	80 mm
CPU	For information on assembly dimensions, refer to the technical data in <i>CPU 31xC and CPU 31x manual, technical data</i> .
Analog input/output modules	40 mm
Digital input/output modules	40 mm
Simulator module SM 374	40 mm
Interface modules IM 360 and IM 365	40 mm
Interface module IM 361	80 mm

- Module height: 125 mm
- Module height with shield connection element 185 mm
- Maximum assembly depth: 130 mm
- Maximum assembly depth of a CPU with an inserted DP connector with angled cable feed: 140 mm
- Maximum assembly depth with open front panel (CPU): 180 mm

Dimensions of other modules such as CPs, FMs etc. are found in the relevant manuals.

Shield connection element

The shield connection element provides you with a comfortable means of bonding all shielded cables of your S7 modules to ground, that is, via direct connection of the shield connection element with the mounting rail.

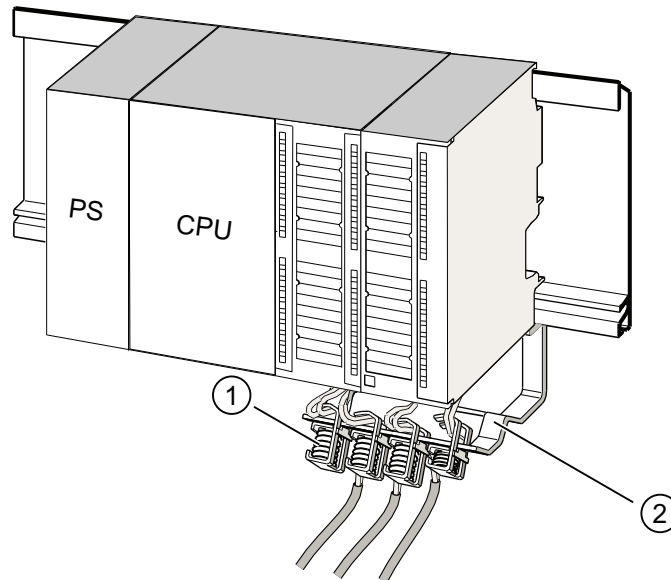

Number	Description
①	Shielding terminals
②	Bracket

Mount the bracket (order number 6ES7390-5AA0-0AA0) to the rail using the two screw bolts. If you use a shield connection element, the dimension specifications apply from the lower edge of the shield connection element.

- Width of the shield connection element: 80 mm
- Number of shielding terminals you can install per shield connection element: max. 4

Table 4- 3 Shielding terminals - Overview

Cable with shielding diameter	Shielding terminal order number
Cable with 2 mm to 6 mm shielding diameter	6ES7390-5AB00-0AA0
Cable with 3 mm to 8 mm shielding diameter	6ES7390-5BA00-0AA0
Cable with 4 mm to 13 mm shielding diameter	6ES7390-5CA00-0AA0

4.4 Specified clearances

You must maintain the clearance shown in the figure in order to provide sufficient space for installing the modules, and to allow the dissipation of heat generated by the modules.

The S7-300 assembly on multiple racks shown in the figure below shows the clearance between racks and adjacent components, cable ducts, cabinet walls etc.

For example, when routing your module wiring through cable duct, the minimum clearance between the bottom edge of the shield connection element and the cable duct is 40 mm.

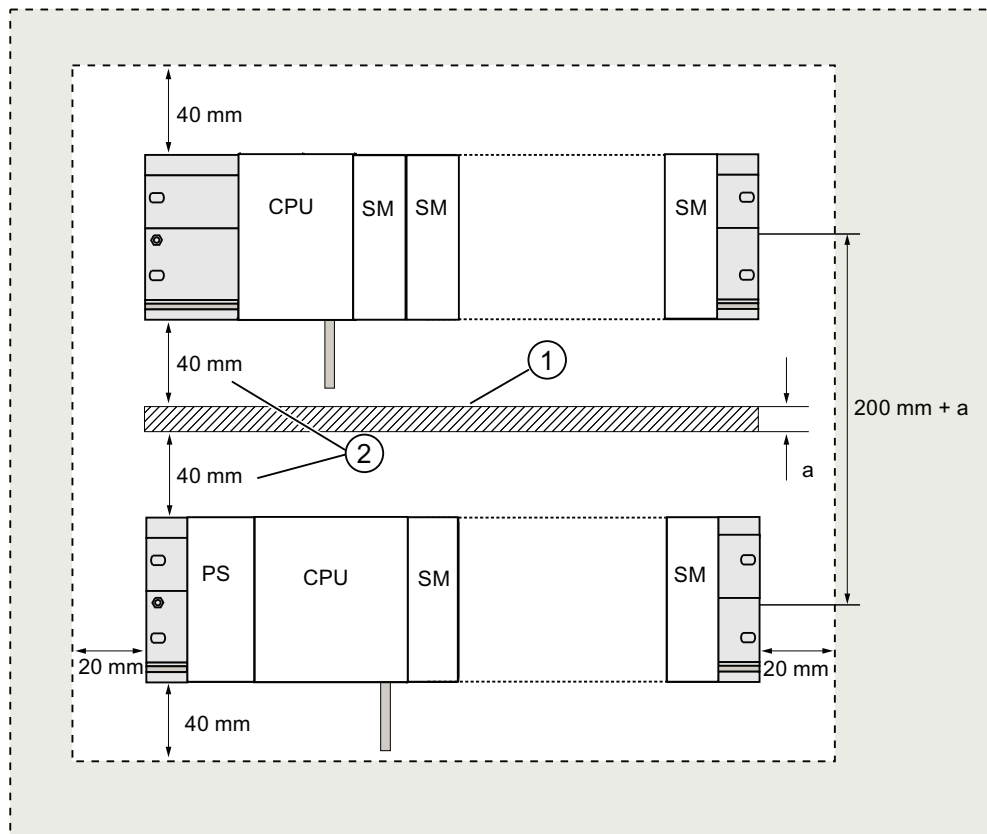

Number	Description
①	Wiring with cable duct
②	Minimum clearance between the cable duct and the bottom edge of the shield connection element is 40 mm.

4.5 Arrangement of modules on a single rack

Reasons for using one or multiple racks

The number of racks you need will depend on your application.

Reasons for using a single rack	Reasons for distributing modules between several racks
<ul style="list-style-type: none"> • Compact, space-saving use of all your modules • Local use of all modules • Fewer signals to be processed 	<ul style="list-style-type: none"> • More signals to be processed • Insufficient number of slots

Note

If you opt for the installation on a single rack, insert a dummy module to the right of the CPU (order no.: 6ES7370-0AA01-0AA0). This gives you the option of adding a second rack for your application if this is necessary later, simply by replacing the dummy module with an interface module, without having to reinstall and rewire the first rack.

Rules: Layout of modules on a single module rack

The following rules apply to module installations on a single rack:

- No more than eight modules (SM, FM, CP) may be installed to the right of the CPU.
- The accumulated power consumption of modules mounted on a rack may not exceed 1.2 A on the S7-300 backplane bus.

Reference

Additional information is available in the technical data, for example, in the SIMATIC S7-300 Automation Systems Manual, Module data, or in the *S7-300 Manual, CPU 31xC and CPU 31x, Technical Data*.

Example

The figure below shows a layout with eight signal modules in an S7-300 assembly.

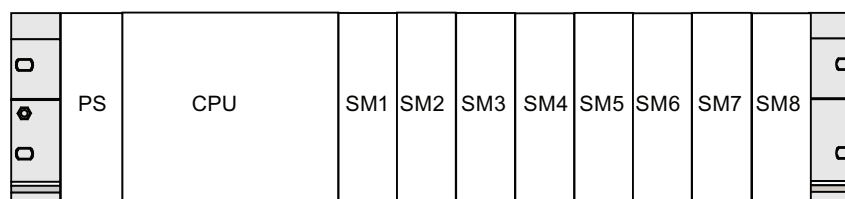

4.6 Distribution of modules to several racks

Exceptions

With CPU 312 and CPU 312C, only a single-row configuration on a rack is possible.

Using interface modules

If you are planning an assembly in multiple racks, then you will need interface modules (IM). An interface module routes the backplane bus of an S7-300 to the next rack.

The CPU is always located on rack 0.

Table 4- 4 Interface modules - Overview

Properties	Two or more rows	Cost-effective 2-row configuration
Send IM in rack 0	IM 360 order no.: 6ES7360-3AA01-0AA0	IM 365 order no.: 6ES7365-0AB01-0AA0
Receiver IM in racks 1 to 3	IM 361 order no.: 6ES7361-3CA01-0AA0	IM 365 (hard-wired to send IM 365)
Maximum number of expansion modules	3	1
Length of connecting cables	1 m (6ES7368-3BB01-0AA0) 2.5 m (6ES7368-3BC51-0AA0) 5 m (6ES7368-3BF01-0AA0) 10 m (6ES7368-3CB01-0AA0)	1 m (hard-wired)
Comments	-	Rack 1 can only receive signal modules; the accumulated current load is limited to 1.2 A, whereby the maximum for rack 1 is 0.8 A. These restrictions do not apply to operation with interface modules IM 360/IM 361

Rules: Distribution of modules to several racks

Please note the following points if you wish to arrange your modules on multiple racks:

- The interface module always uses slot 3 (slot 1: power supply module; slot 2: CPU, slot 3: Interface module)
- It is always on the left before the first signal module.
- No more than 8 modules (SM, FM, CP) are permitted per rack.
- The number of modules (SM, FM, CP) is limited by the permitted current consumption on the S7-300 backplane bus. The cumulative current consumption of 1.2 A in row 0 (CPU) and 0.8 A each in the expansion rows 1 to 3 must not be exceeded.

Note

The current consumption of specific modules is listed in the *SIMATIC S7-300 Automation Systems Manual, Module data*.

Rules: Interference-proof interfacing

Special shielding and grounding measures are not required if you interconnect the CU and EM using suitable interface modules (Send IM and Receive IM).

However, you must ensure

- a low impedance interconnection of all racks,
- that the racks of a grounded assembly are grounded in a star pattern,
- that the contact springs on the racks are clean and not bent, thus ensuring that interference currents are properly discharged to ground.

Example: Full assembly using four racks

The figure shows the arrangement of modules in an S7-300 assembly on 4 racks.

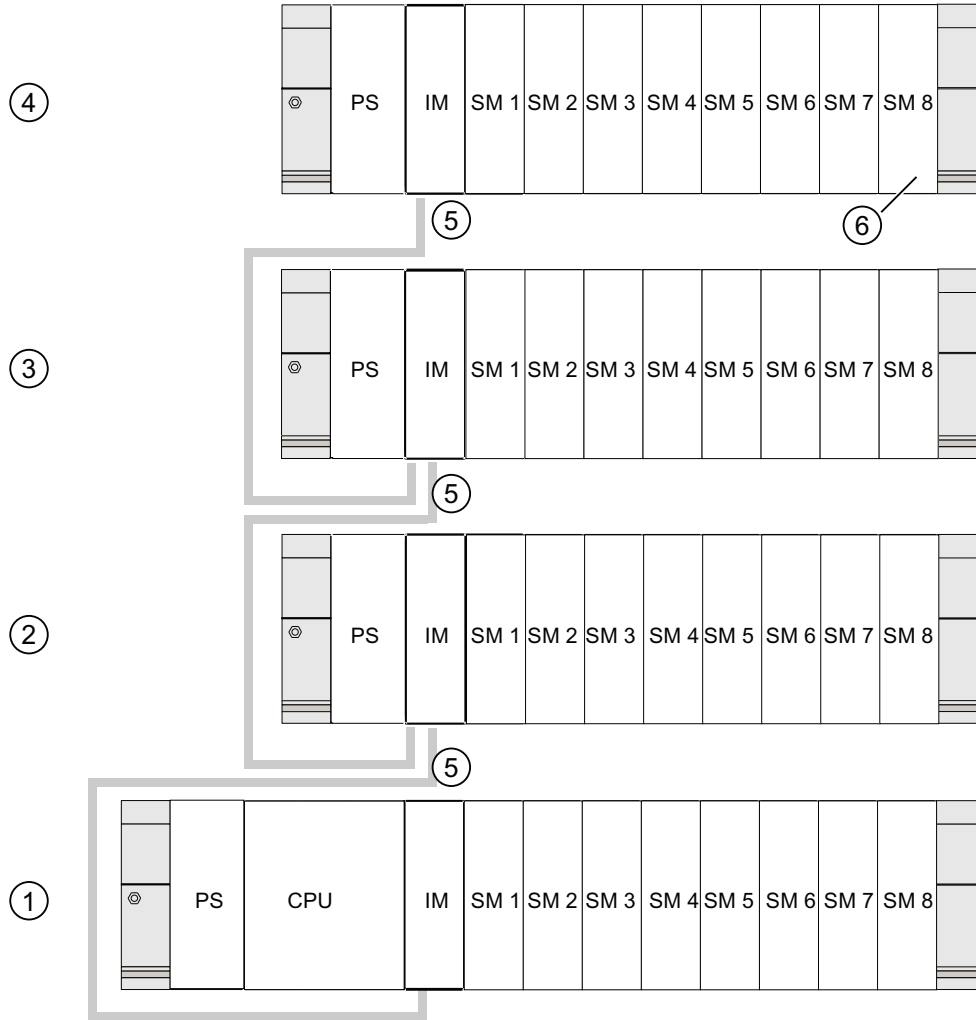

- | Number | Description |
|--------|--|
| ① | Rack 0 (central unit) |
| ② | Rack 1 (expansion module) |
| ③ | Rack 2 (expansion module) |
| ④ | Rack 3 (expansion module) |
| ⑤ | Connection line 368 |
| ⑥ | Limitation for CPU 31xC
When this CPU is used, do not insert signal module 8 into Rack 4. |

4.7 Selection and installation of cabinets

Reasons for installing an S7-300 in a cabinet

Your S7-300 should be installed in a cabinet,

- if you plan a larger system,
- if you are using your S7-300 systems in an environment subject to interference or contamination, and
- to meet UL/CSA requirements for cabinet installation.

Selecting and dimensioning cabinets

Take the following criteria into account:

- ambient conditions at the cabinet's place of installation
- the specified mounting clearance for racks (mounting rails)
- accumulated power loss of all components in the cabinet.

The ambient conditions (temperature, humidity, dust, chemical influence, explosion hazard) at the cabinet's place of installation determine the degree of protection (IP xx) required for the cabinet.

Reference for degrees of protection

For additional information on the degrees of protection, refer to IEC 60529 and DIN 40050.

The power dissipation capability of cabinets

The power dissipation capability of a cabinet depends on its type, ambient temperature and on the internal arrangement of devices.

Reference for power loss

For detailed information on dissipatable power loss, refer to the Siemens catalogs. You can find these at: <https://mall.automation.siemens.com/de/guest/guiRegionSelector.asp> (<https://mall.automation.siemens.com/de/guest/guiRegionSelector.asp>)

Specification of cabinet dimensions

Note the following specifications when you determine the dimensions of a cabinet for your S7-300 installation:

- Space required for racks (mounting rails)
- Minimum clearance between the racks and cabinet walls
- Minimum clearance between the racks
- Space required for cable ducts or fan assemblies
- Position of the stays

 WARNING
Modules may get damaged if exposed to excess ambient temperatures.



Reference for ambient temperatures

For information on permitted ambient temperatures, refer to the *S7-300 Automation System, Module Data Manual*.

Overview of typical cabinet types

The table below gives you an overview of commonly used cabinet types. It shows you the applied principle of heat dissipation, the calculated maximum power loss and the degree of protection.

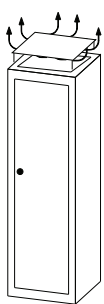
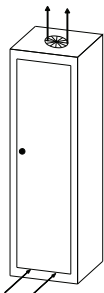
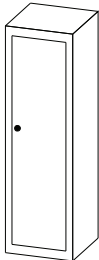
Table 4- 5 Cabinet types

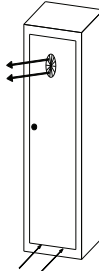
Open cabinets		Closed cabinets		
Through-ventilation by natural convection	Increased through-ventilation	Natural convection	Forced convection with rack fan, improvement of natural convection	Forced convection with heat exchanger, internal and external auxiliary ventilation
				

Open cabinets		Closed cabinets		
Mainly inherent heat dissipation, with a small portion across the cabinet wall.	Higher heat dissipation with increased air movement.	Heat dissipation only across the cabinet wall; only low power losses permitted. In most cases, the heat accumulates at the top of the cabinet interior.	Heat dissipation only across the cabinet wall. Forced convection of the interior air improves heat dissipation and prevents heat accumulation.	Heat dissipation by heat exchange between heated internal air and cool external air. The increased surface of the pleated profile of the heat exchanger wall and forced convection of internal and external air provide good heat dissipation.
Degree of protection IP 20	Degree of protection IP 20	Degree of protection IP 54	Degree of protection IP 54	Degree of protection IP 54
Typical power dissipation under following marginal conditions:				
<ul style="list-style-type: none"> Cabinet size: 600 mm x 600 mm x 2,200 mm Difference between the outer and inner temperature of the cabinet is 20 °C (for other temperature differences refer to the temperature charts of the cabinet manufacturer) 				
up to 700 W	up to 2,700 W (with fine filter up to 1,400 W)	up to 260 W	up to 360 W	up to 1,700 W

4.8 Example: Selecting a cabinet

Introduction

The sample below clearly shows the maximum permitted ambient temperature at a specific power loss for different cabinet designs.

Installation

The following device configuration should be installed in a cabinet:

- Central unit, 150 W
- Expansion modules, each with 150 W
- Load power supply under full load, 200 W

This results in an accumulated power loss of 650 W.

Power loss dissipated

The diagram in the figure below shows guide values for the permitted ambient temperature of a cabinet with the dimensions 600 mm x 600 mm x 2000 mm, based on the accumulated power loss. These values only apply if you maintain the specified assembly and clearance dimensions for racks (rails).

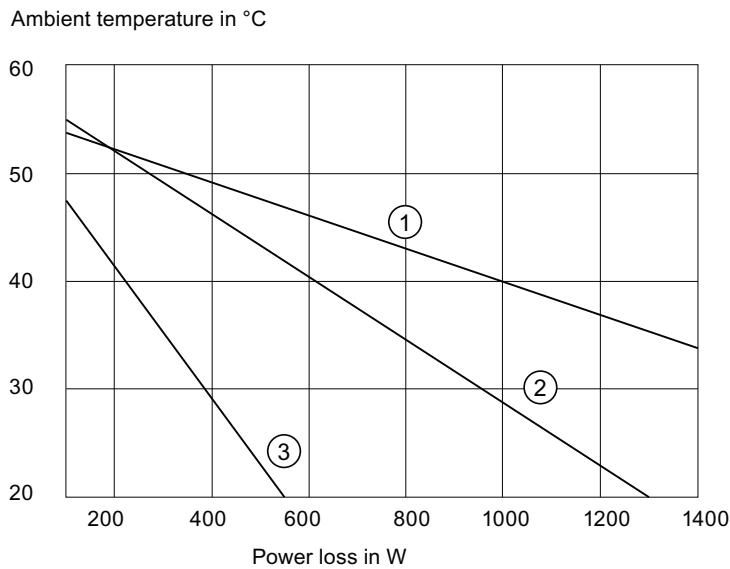

Number	Description
①	Closed cabinet with heat exchanger (heat exchanger size 11/6 (920 x 460 x 111 mm))
②	Cabinet with through-ventilation by natural convection
③	Closed cabinet with natural convection and forced convection by equipment fans

Result

The figure below shows the resultant ambient temperatures, based on an accumulated power loss of 650 W:

Table 4- 6 Cabinet selection

Cabinet design	Maximum permitted ambient temperature
Closed with natural convection and forced convection (trend 3)	Operation not possible
Open with through-ventilation (trend 2)	approx. 38 °C
Closed with heat exchanger (trend 1)	approx. 45 °C

Cabinet types suitable for horizontal installation of the S7-300:

- open, with closed ventilation
- closed, with heat exchanger

4.9 Electrical assembly, protective measures and grounding

4.9.1 Grounding concept and overall structure

This section contains information about the overall configuration of an S7-300 connected to a grounded TN-S network:

- Circuit-breaking devices, short-circuit and overload protection to VDE 0100 and VDE 0113
- Load power supplies and load circuits
- Grounding concept

Note

An S7-300 can be used in many different ways, so we can only describe the basic rules for the electrical installation in this document. Those basic rules are a must in order to achieve a fully functional S7-300 system.

Definition: Grounded mains

In a grounded mains network, the neutral conductor is always bonded to ground. A short-circuit to ground of a live conductor, or of a grounded part of the system, trips the protective devices.

Specified components and protective measures

A number of components and protective measures are prescribed for plant installations. The type of components and the degree of compulsion pertaining to the protective measures will depend on the VDE specification applicable to your particular plant.

The table below shows components and protective measures.

Table 4- 7 VDE specifications for the installation of a PLC system

Compare ...	1)	VDE 0100	VDE 0113
Disconnect devices for control systems, signal generators and final control elements	(1)	... Part 460: Master switch	... Part 1: Load disconnect switch
Short-circuit / overload protection: In groups for signal generators and final control elements	(2)	... Part 725: Single-pole fusing of circuits	... Part 1: <ul style="list-style-type: none"> • With grounded secondary power circuit: single-pole fusing • Otherwise: fusing of all poles
Load power supply for AC load circuits with more than five electromagnetic devices	(3)	Galvanic isolation by transformer recommended	Galvanic isolation by transformer mandatory

1) This column refers to the numbers in the figure in the chapter "Overview: Grounding".

Reference

For additional information on protective measures, refer to the Appendix.

See also

Overview: Grounding (Page 52)

4.9.2 Installing an S7-300 with grounded reference potential

Introduction

When the S7-300 is configured with a grounded reference potential, any interference currents are discharged to the grounding conductor / ground. A grounding slide contact is used for this except with CPU 31xC.

Note

Your CPU is supplied with grounded reference potential. Therefore, if you wish to install an S7-300 with grounded reference potential, you do not need to modify your CPU!

Grounded reference potential of the CPU 31x

The figure shows an S7-300 configuration with grounded reference potential (factory state.)

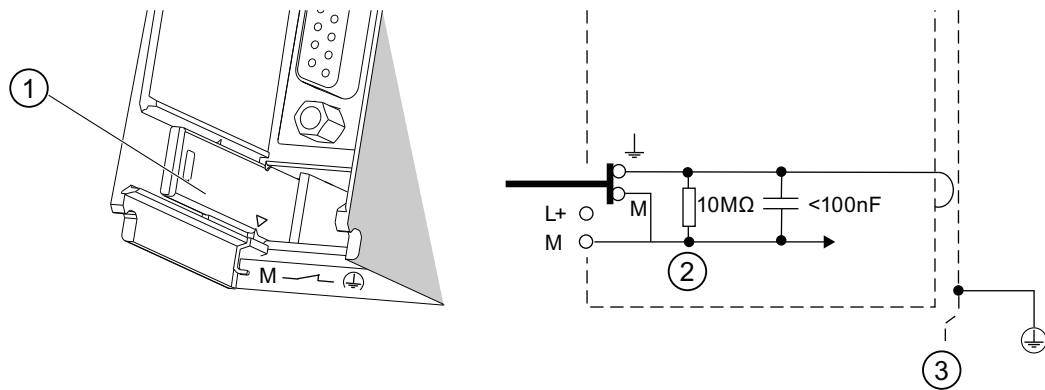

Number	Description
①	Grounding slide contact in grounded state
②	Ground potential of the internal CPU circuitry
③	Mounting rail

Note

Do not pull out the grounding slide contact when you install an S7-300 with grounded reference potential.

4.9.3 Installing an S7-300 with ungrounded reference potential (not CPU 31xC)

Introduction

When the S7-300 is configured with an ungrounded reference potential, interference currents are discharged to the ground conductor / to ground via an RC combination integrated in the CPU.

Note

An S7-300 with a CPU 31xC cannot be configured ungrounded.

Application

In large systems, the S7-300 may require a configuration with grounded reference potential due to ground-fault monitoring. This is the case, for example, in chemical industry and power stations.

Ungrounded reference potential of the CPU 31x

The figure demonstrates how to achieve a reference potential without grounding in an S7-300 installation.

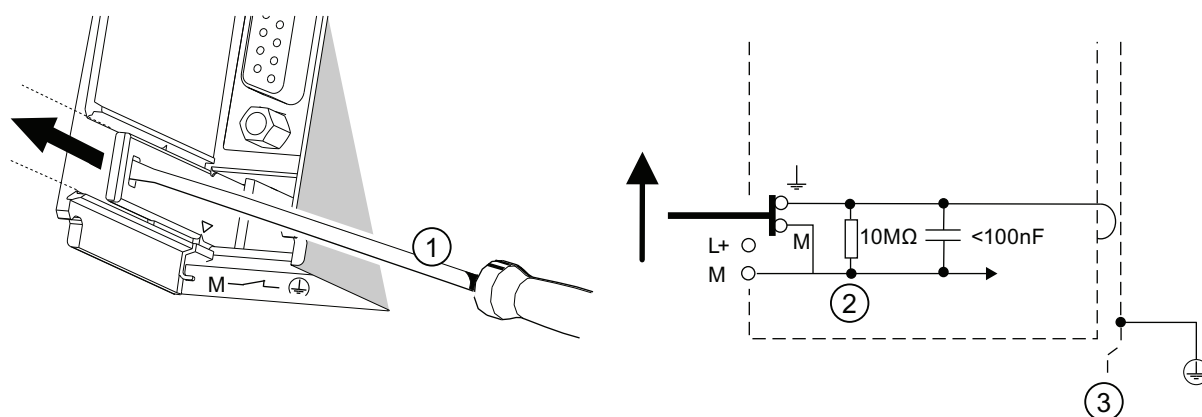

Number Description

- ① Creating an ungrounded reference potential in your CPU
Use a screwdriver with 3.5 mm blade width to push the grounding slide contact forwards in the direction of the arrow until it snaps into place.
- ② Ground potential of the internal CPU circuitry
- ③ Mounting rail

Note

You should set up the ungrounded reference potential before you mount the device on the rail. If you have already installed and wired the CPU, you may have to disconnect the MPI interface before you pull out the grounding slide contact.

4.9.4 Isolated or non-isolated modules?

Isolated modules

Isolated modules are installed with galvanic isolation between the reference potentials of the control circuit (M_{internal}) and load circuit (M_{external}).

Field of application

Use isolated modules for:

- All AC load circuits
- DC load circuits with separate reference potential

Examples:

- DC load circuits containing sensors which are connected to different reference potentials (for example, if grounded sensors are located at a considerable distance from the control system and equipotential bonding is not possible).
- DC load circuits with grounded positive pole (L+) (battery circuits).

Isolated modules and grounding concept

You can always use isolated modules, irrespective of the grounding state of the control system's reference potential.

Example: Assembly with CPU 31xC and isolated modules

The figure below shows an example of such a configuration: A CPU 31xC with isolated modules. The CPU 31xC (1) is automatically grounded.

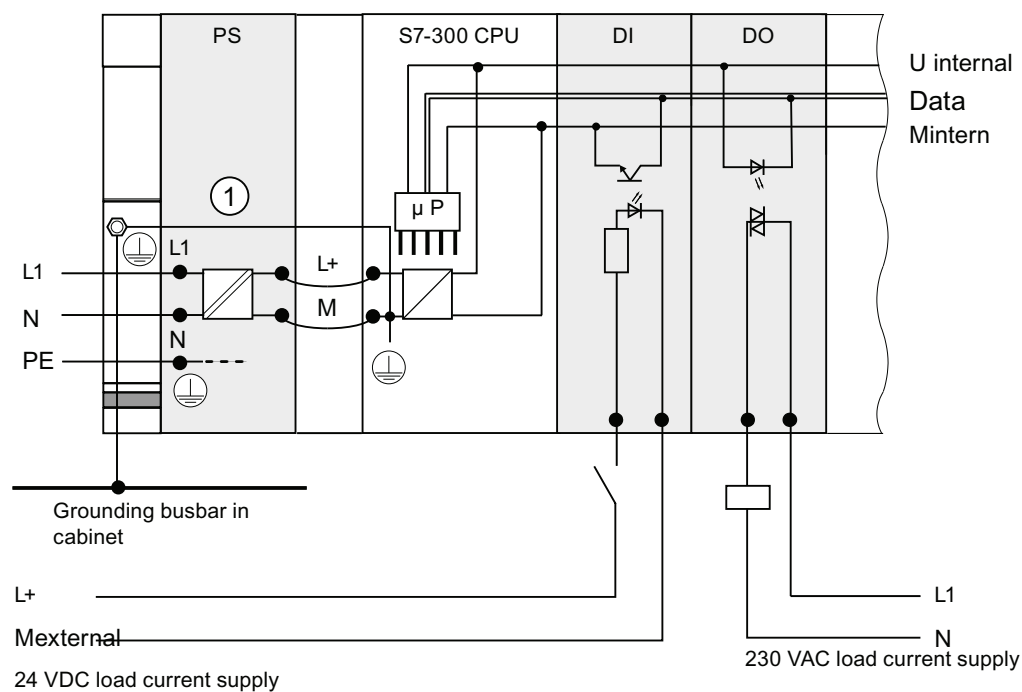

Common potential modules

In a configuration containing modules with common potential, the reference potentials of the control circuit (M_{internal}) and analog circuit (M_{analog}) are not galvanically isolated.

Example: Installing an S7-300 with common potential modules

When using an SM 334 AI 4/AO 2 analog input/output module, connect one of the grounding terminals M_{analog} to the CPU chassis ground.

The figure below shows an example of such a configuration: An S7-300 with common potential modules

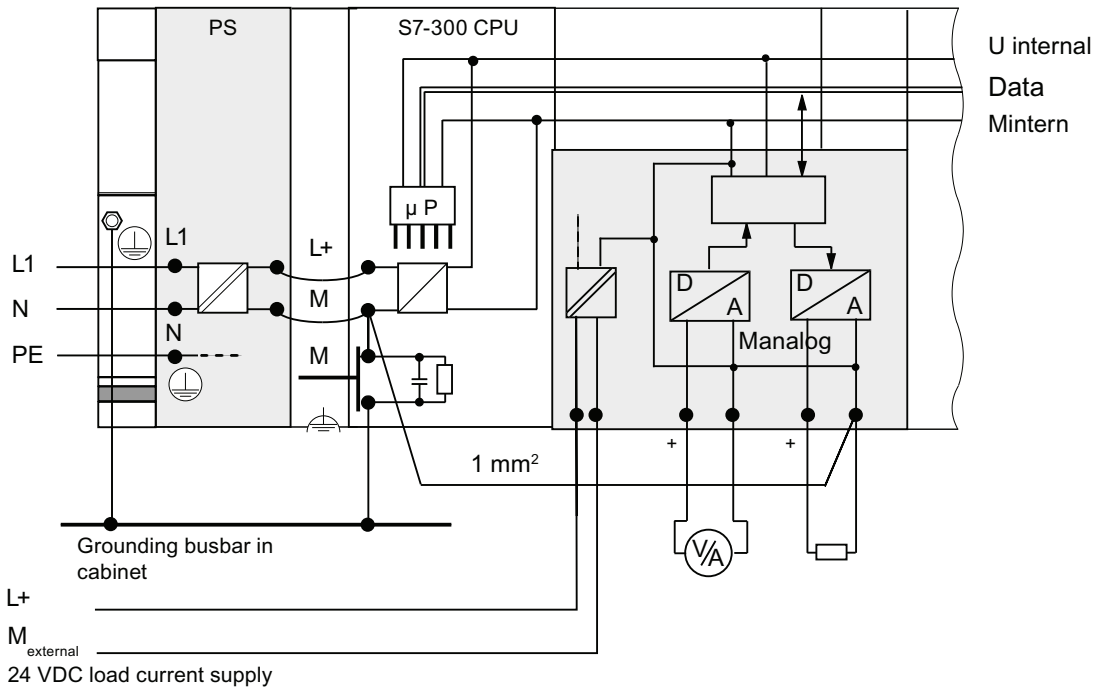

4.9.5 Grounding measures

Bonding to ground

Low-impedance connections to ground reduce the risk of electric shock as a result of a short-circuit or system fault. Low-impedance connections (large surface, large-surface contact) reduce the effects of interference on the system or the emission of interference signals. An effective shielding of cables and devices is also a significant contribution.



WARNING

All protection class 1 devices, and all larger metal parts, must be bonded to protective ground. That is the only way to safely protect operators from electrical shock. This also discharges any interference transmitted from external power supply cables, signal cables or cables to the I/O devices.

Measures for protective grounding

The table below shows an overview of the most important measures for protective grounding.

Table 4- 8 Measures for protective grounding

Device	Measures
Cabinet / mounting frame	Connection to a central grounding point (grounding busbar, for example) using cables with protective conductor quality.
Rack/ mounting rail	Connection to a central grounding point via cable with minimum cross-section of 10 mm ² if the mounting rails are not installed in the cabinet and not interconnected with larger metal parts.
Module	None
I/O Device	Grounding via grounding-type plug
Sensors and final control elements	Grounding in accordance with regulations applying to the system

Rule: Connect the cable shielding to ground

You should always connect both ends of the cable shielding to ground / system ground. This is the only way to achieve an effective interference suppression in the higher frequency range.

Attenuation is restricted to the lower frequency range if you connect only one end of the shielding (that is, at the start or end of the cable) to ground. One-sided shielding connections could be more favorable in situations

- not allowing the installation of an equipotential bonding conductor,
- where analog signals (some mA or μ A) are transferred,
- or if foil shielding is used (static shielding).

Note

Whenever potential differences develop between two grounding points, an equalizing current can develop on a shielding that is connected on both ends. Compensate for this situation by installing an additional equipotential cable.

 CAUTION
Always avoid the flow of operating current to ground.

Rule: Grounding the load circuits

You should always ground the load circuits. This common reference potential (ground) ensures proper functioning.

Note

(not valid for CPU 31xC)

If you want to locate a ground fault, provide your load power supply (terminal L- or M) or the isolating transformer with a removable connection to the protective conductor (see *Overview: Grounding* Number 4).

Connecting the load voltage reference potential

A complex system containing many output modules requires an additional load voltage for switching the final control elements.

The table below shows how to connect the load voltage reference potential M_{external} for the various configurations.

Table 4- 9 Connecting the load voltage reference potential

Installation	common potential modules	isolated modules	Comment
grounded	Connect M_{external} with M on the CPU	Connect or do not connect M_{external} to the grounding busbar	-
ungrounded	Connect M_{external} with M on the CPU	Connect or do not connect M_{external} to the grounding busbar	Ungrounded installation with CPU 31xC is not possible

4.9.6 Overview: Grounding

CPU 31xC

The figure below shows you the complete assembly of an S7-300 with CPU 31xC with a power supply from TN-S mains. The PS 307 supplies the CPU and the load current circuit of the 24 VDC modules. Remark: The layout of the power connections does not correspond with their physical arrangement; it was merely selected to give you a clear overview.

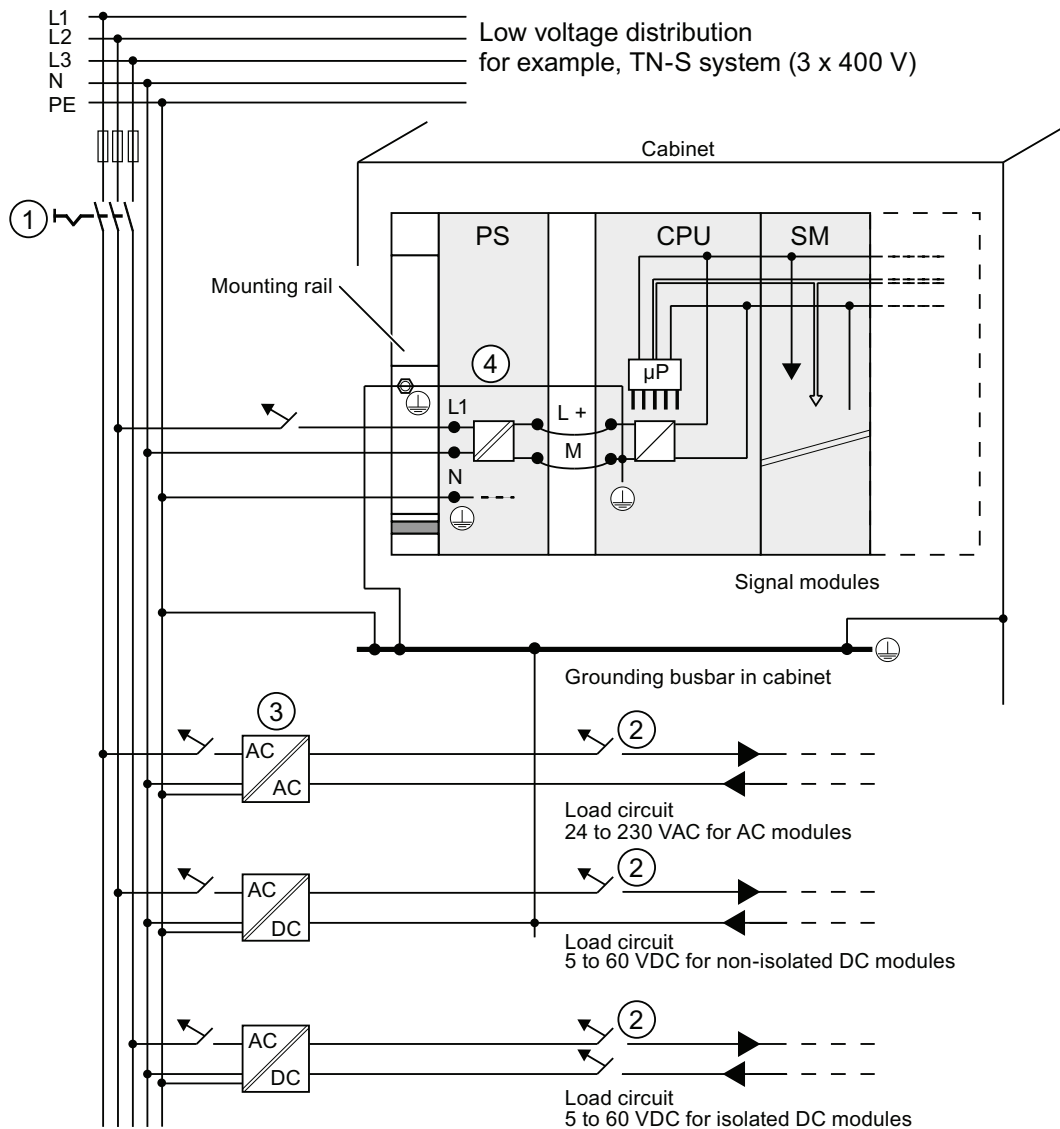

Number	Description
①	Master switch
②	Short-circuit and overload protection
③	Load current supply (galvanic isolation)
④	This connection is made automatically for the CPU 31xC.

Figure 4-1 Connecting the load voltage reference potential

All CPUs except CPU 31xC

The figure below shows you the complete assembly of an S7-300 with TN-S mains supply (does not apply to CPU 31xC). The PS 307 supplies the CPU and the load current circuit of the 24 VDC modules.

Remark: The layout of the power connections does not correspond with their physical arrangement; it was merely selected to give you a clear overview.

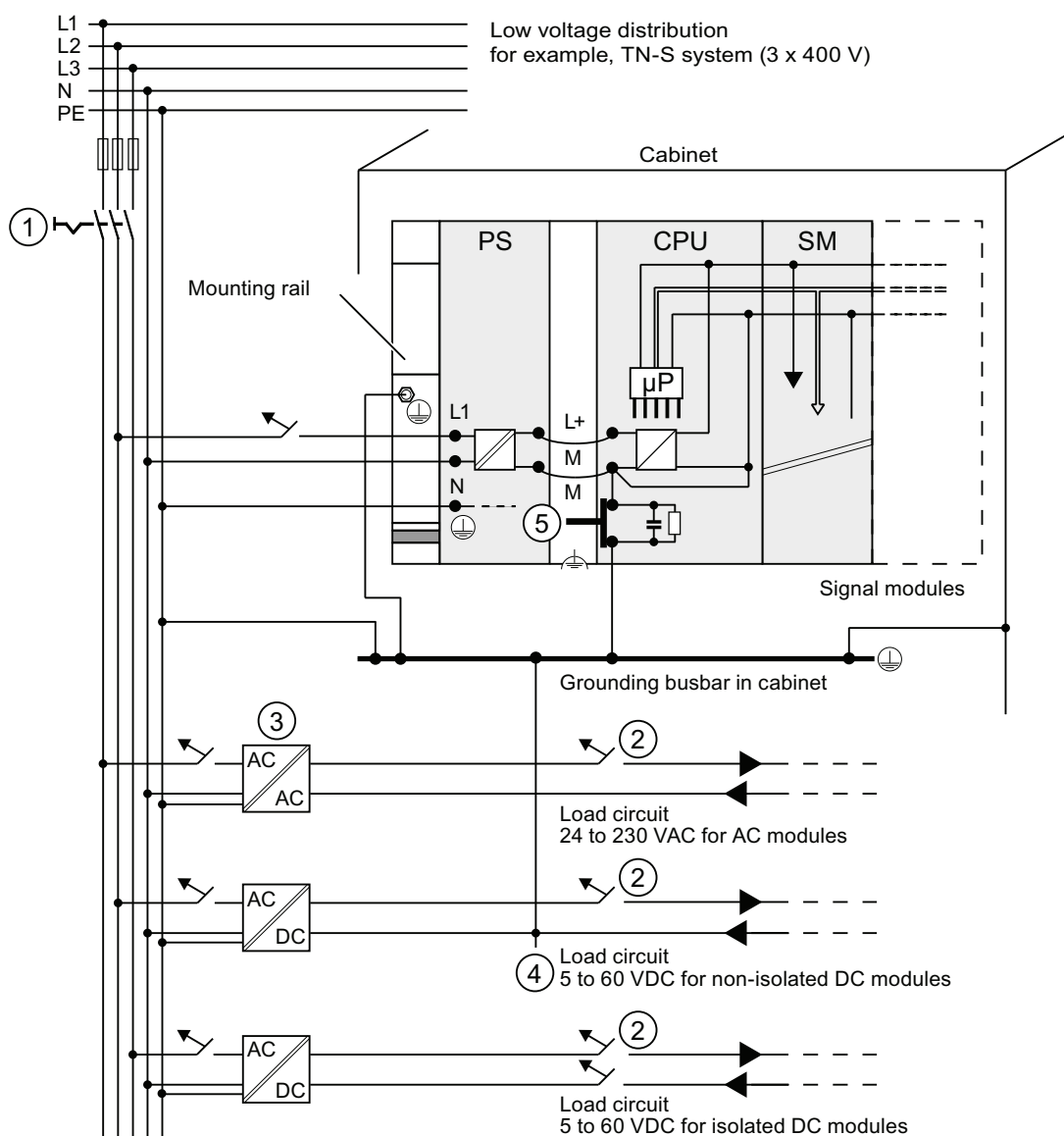

Number Description

- ① Master switch
- ② Short-circuit and overload protection
- ③ The load current supply (galvanic isolation)
- ④ Removable connection to the grounding conductor, for ground fault localization
- ⑤ Grounding slide contact of the CPU (not CPU 31xC)

Figure 4-2 Connecting the load voltage reference potential

4.10 Selection of the load power supply

Task of the load power supply

The load power supply feeds the input and output circuits (load circuits), and the sensors and actuators.

Features of load power supply units

You will have to adapt the load power supply unit to your specific application. The table below shows a comparison of the various load power supply units and their features to help you make your choice:

Table 4- 10 Features of load power supply units

Necessary for ...	Feature of the load power supply	Comments
Modules requiring voltage supplies ≤ 60 VDC or ≤ 25 VAC. 24 VDC load circuits	Safety isolation	This is a common feature of the Siemens power supply series PS 307 and SITOP power series 6EP1.
24 VDC load circuits 48 VDC load circuits 60 VDC load circuits	Output voltage tolerances: 19.2 V to 28.8 V 40.8 V to 57.6 V 51 V to 72 V	-

Load power supply requirements

Only an extra-low voltage of ≤ 60 VDC which is safely isolated from mains may be used as load voltage. Safe isolation can be achieved in accordance with the requirements in, for example, VDE 0100 Part 410/HD 384-4-41/IEC 364-4-41 (as functional extra-low voltage with safe isolation) or VDE 0805/EN 60950/IEC 950 (as safety extra-low voltage SELV) or VDE 0106 Part 101.

Load current determination

The required load current is determined by the accumulated load current of all sensors and actuators connected to the outputs.

A short-circuit induces a surge current at the DC outputs which is 2 to 3 times higher than the rated output current, until the clocked electronic short-circuit protection comes into effect. Make allowances for this increased short-circuit current when selecting your load power supply unit. Uncontrolled load power supplies usually provide this excess current. With controlled load power supplies, and particularly for low output power up to 20 A, always ensure that the supply can handle this excess current.

Example: S7-300 with load power supply from PS 307

The figure below shows the overall S7-300 configuration (load power supply unit and grounding concept), with TN-S mains supply. The PS 307 supplies the CPU and the load current circuit of the 24 VDC modules.

Note

The layout of the power connections does not correspond with their physical arrangement; it was merely selected to give you a clear overview.

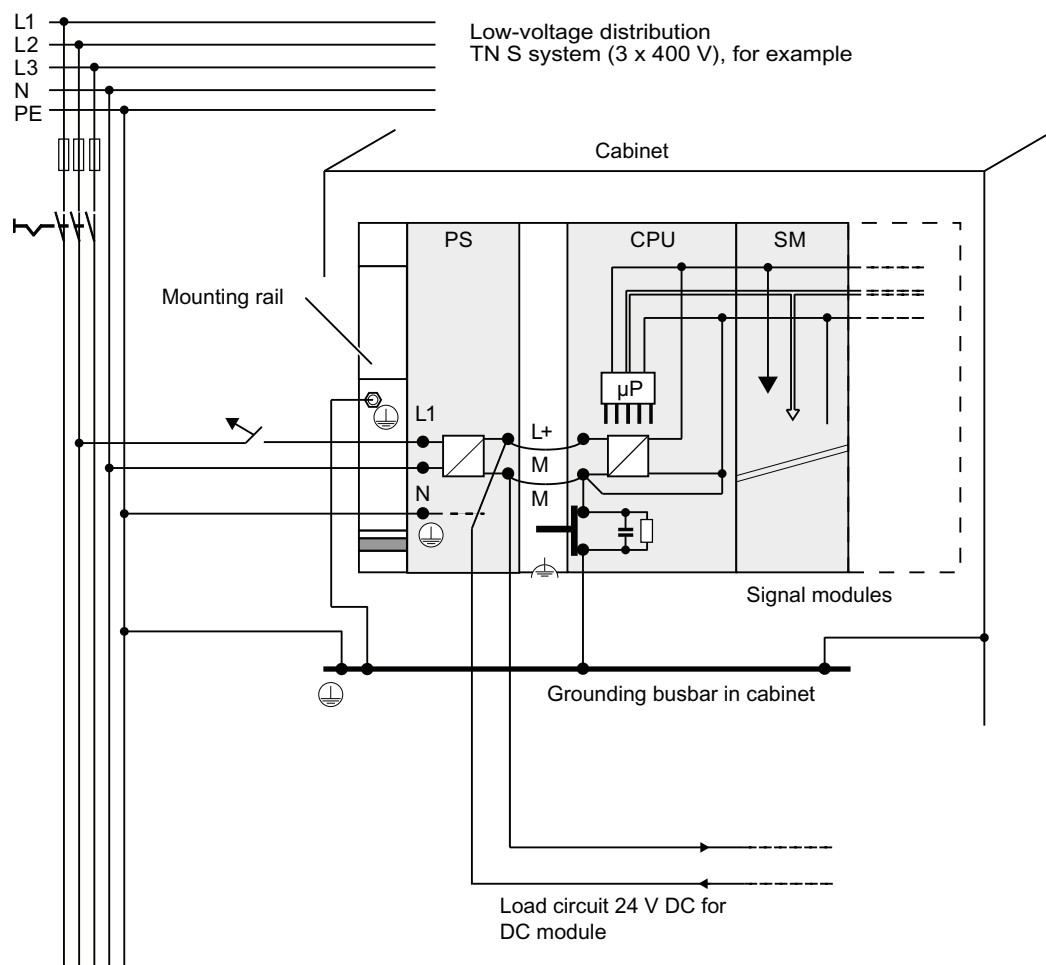

Example: S7-300 with load power supply from PS 307

4.11 Planning subnets

4.11.1 Overview

Subnets

Subnets available in SIMATIC for the various automation levels (process, cell, field and actuator/sensor level):

- Multi-Point Interface (MPI)
- PROFIBUS
- PROFINET (Industrial Ethernet)
- Point-to-point communication (PtP)
- Actuator/Sensor Interface (ASI)

Multi-Point Interface (MPI)

Availability: For all CPUs described in this document.

MPI is a small area subnet containing a small number of nodes at the field/cell level. It is a multipoint-capable interface in SIMATIC S7/M7 and C7. designed as PG interface, for networking a small number of CPUs, or for low volume data exchange with PGs.

MPI always retains the last configuration of the transmission rate, node number and highest MPI address, even after CPU memory reset, power failure or deletion of the CPU parameter configuration.

It is advisable to use the PROFIBUS DP network components for your MPI network configuration. The same configuration rules apply. Exception: OWG modules are not allowed in the MPI network.

PROFIBUS

Availability: CPUs with the "DP" name suffix are equipped with a PROFIBUS interface (CPU 315-2 DP, for example).

PROFIBUS represents the network at the cell and field level in the SIMATIC open, multivendor communication system.

PROFIBUS is available in two versions:

1. PROFIBUS DP field bus for high-speed cyclic data exchange, and PROFIBUS-PA for intrinsically safe applications (requires DP/PA coupler).
2. The cell level as PROFIBUS (FDL or PROFIBUS FMS) for high-speed data exchange with communication partners at the same authorization level (can only be implemented via CP).

PROFINET (Industrial Ethernet)

Availability: CPUs with the "PN" name suffix are equipped with a PROFINET interface (CPU 317-2 PN/DP or CPU 319-3 PN/DP for example). A PROFINET interface, or communication processors, can be used to implement Industrial Ethernet in an S7-300 CPU system.

Industrial Ethernet, in an open multivendor communication system, represents the SIMATIC network at the process and cell level. PROFINET CPUs, however, also support real-time communication at the field level. This structure also supports S7 communication. Industrial Ethernet is suitable for high-speed and high-volume data exchange, and for remote network operations via gateway.

PROFINET is available in two versions:

- PROFINET IO and
- PROFINET CBA.

PROFINET IO is a communication concept for the implementation of modular, distributed applications. PROFINET IO allows you to create automation solutions you are familiar with from PROFIBUS.

PROFINET CBA (Component based automation) is an automation concept for the implementation of applications with distributed intelligence. PROFINET CBA lets you create distributed automation solutions, based on default components and partial solutions. This concept satisfies demands for a higher degree of modularity in the field of mechanical and systems engineering by extensive distribution of intelligent processes.

Component based automation allows you to use complete technological modules as standardized components in large systems.

Point-to-point communication (PtP)

Availability: CPUs with "PtP" name suffix are equipped with a second interface, namely the PtP interface (CPU 314C-2 PtP, for example)

PtP does not represent a subnet in the common sense, because it is used to interconnect only two stations.

If a PtP interface is not available, you require PtP Communication Processors (CP).

Actuator/Sensor Interface (ASI)

Implementation by means of communication processors (CP).

The ASI, or actuator/sensor interface, represents a subnet system on the lowest process level for automation systems. It is designed especially for networking digital sensors and actuators. The maximum data volume is 4 bit per slave station.

S7-300 CPUs require communication processor for the ASI connection.

Reference

For additional information on communication, refer to the *Communication with SIMATIC* manual.

4.11.2 Configuring MPI and PROFIBUS subnets

4.11.2.1 Overview

The next section contains all the information you require to configure MPI, PtP and PROFIBUS subnets:

Contents

- MPI, PtP and PROFIBUS subnets
- Multi-Point Interface
- PROFIBUS DP
- MPI and PROFIBUS network components
- Example of networks - MPI

4.11.2.2 Basic information relating to MPI and PROFIBUS subnets

Convention: device = node

All devices you interconnect on the MPI or PROFIBUS network are referred to as nodes.

Segment

A segment is a bus line between two terminating resistors. A segment may contain up to 32 nodes. It is also limited with respect to the permitted line length, which is determined by the transmission rate.

Baud rate

Maximum transmission rates:

- MPI:
 - CPU 314C-2 PN/DP, CPU 315-2 PN/DP, CPU 317 and CPU 319-3 PN/DP: 12 Mbit/s
 - All other CPUs: 187,5 kbit/s
- PROFIBUS DP: 12 Mbit/s

Number of nodes

Maximum number of nodes per subnet.

Table 4- 11 Subnet nodes

Parameters	MPI	PROFIBUS DP
Number	127	126 ¹
Addresses	0 to 126	0 to 125
Comment	Default: 32 addresses Reserved addresses: <ul style="list-style-type: none"> • Address 0 for PG • Address 1 for OP 	of those: <ul style="list-style-type: none"> • 1 master (reserved) • 1 PG connection (address 0 reserved) • 124 slaves or other masters

¹ Note the CPU-specific maximum specifications in the relevant CPU manual.

MPI/PROFIBUS DP addresses

You need to assign an address to all nodes in order to enable intercommunication:

- On the MPI network: an "MPI address"
- On the PROFIBUS DP network: "a PROFIBUS DP address"

You can use the PG to set the MPI/PROFIBUS addresses for each one of the nodes (some of the PROFIBUS DP slaves are equipped with a selector switch for this purpose).

Default MPI/PROFIBUS DP addresses

The table below shows you the default setting of the MPI/PROFIBUS DP addresses, and the factory setting of the highest MPI/PROFIBUS DP addresses for the nodes.

Table 4- 12 MPI/PROFIBUS DP addresses

Node (device)	Default MPI/ PROFIBUS DP address	Default highest MPI address	Default highest PROFIBUS DP address
PG	0	32	126
OP	1	32	126
CPU	2	32	126

Rules: Assignment of MPI/PROFIBUS DP addresses

Note the following rules before assigning MPI/PROFIBUS addresses:

- All MPI/PROFIBUS subnet addresses must be unique.
- The highest MPI/PROFIBUS address must be greater than or equal to the actual MPI/ PROFIBUS address and must be identical for each node. (Exception: connecting a PG to multiple nodes; refer to the next chapter).

Differences in the MPI addresses of CPs/FMs in an S7300 system

Table 4- 13 MPI addresses of CPs/FMs in an S7-300 system

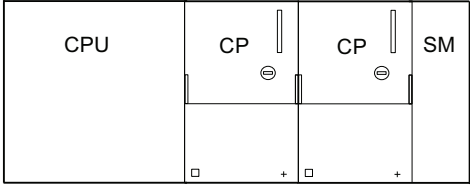
Options	Example			
<p>Example: A system containing an S7-300 CPU and 2 CPs. You have two options of assigning MPI addresses to CPs/FMs installed in a system:</p>				
<p>1st option: The CPU accepts the MPI addresses you set for the CPs in STEP 7.</p>	CPU	CP	CP	SM
<p>2nd option: The CPU automatically assigns MPI addresses to the CPs in its system, based on the following syntax: MPI address CPU; MPI address + 1; MPI addr. + 2. (Default)</p>	MPI addr.	MPI addr. + x	MPI addr. + y	
<p>Special feature: CPU 314C-2 PN/DP, CPU 315-2 PN/DP, CPU 317 and CPU 319-3 PN/DP</p>	<p>When the central rack of an S7-300 contains FM/CPs with their own MPI address, the CPU forms its own communication bus via the backplane bus for these FM/CPs and separates it from the other subnets. The MPI address of those FM/CPs is thus no longer relevant for the nodes on other subnets. The MPI address of the CPU is used to communicate with these FMs/CPs.</p>			

Recommendation for MPI addresses

Reserve MPI address "0" for a service PG, or "1" for a service OP, for temporary connections of these devices to the subnet. You should therefore assign different MPI addresses to PGs/OPs operating on the MPI subnet.

Recommended MPI address of the CPU for replacement or service operations:

Reserve MPI address "2" for the CPU. This prevents duplication of MPI addresses after you connect a CPU with default settings to the MPI subnet (for example, when replacing a CPU). You should assign an MPI address greater than "2" to CPUs in the MPI subnet.

Recommendation for PROFIBUS addresses

Reserve PROFIBUS address "0" for a service PG that you can subsequently connect briefly to the PROFIBUS subnet as required. You should therefore assign unique PROFIBUS addresses to PGs integrated in the PROFIBUS subnet.

PROFIBUS DP: Electrical cables or fiber-optic cables?

Use fiber optic cables on a field bus with greater length, rather than copper conductors, in order to be independent on the transmission rate, and to exclude external interference.

Equipotential bonding

For information on what to take into account with respect to equipotential bonding in your network configuration, refer to the corresponding chapter in the appendix.

Reference

For more information, refer to the Communication section in *CPU 31xC and CPU 31x manual, technical data*.

4.11.2.3 Multi-Point Interface (MPI)

Availability

All the CPUs described here are equipped with an MPI interface

A CPU equipped with an MPI/DP interface is configured and supplied as MPI interface.

Properties

The MPI (Multi-Point Interface) represents the CPU interface for PG/OP connections, or for communication on an MPI subnet.

The default baud rate of all CPUs is 187.5 kbps. You can also set 19.2 kbps for communication with an S7-200. Baud rates up to max. 12 Mbps are possible with the CPU 314C-2 PN/DP, CPU 315-2 PN/DP, CPU 317-2 and with the CPU 319-3 PN/DP.

The CPU automatically broadcasts its bus configuration via the MPI interface (the transmission rate, for example). A PG, for example, can thus receive the correct parameters and automatically connect to a MPI subnet.

Devices capable of MPI communication

- PG/PC
- OP/TP
- S7-300 / S7-400 with MPI interface
- S7-200 (only at 19.2 kbps)

NOTICE
You may only connect PGs to an MPI subnet which is in RUN. Do not connect other stations (for example, OP, TP) to the MPI subnet while the system is running. Otherwise, transferred data might be corrupted as a result of interference, or global data packages may be lost.

Clock synchronization

The CPU's MPI interface supports clock synchronization. Detailed information is available in the *Manual CPU 31x and CPU 31x, Technical specifications, section Clock synchronization*.

4.11.2.4 PROFIBUS DP interface

Availability

CPUs with the "DP" have at least one DP interface.

The CPU 314C-2 PN/DP, CPU 315-2 PN/DP and the CPU 317-2 PN/DP feature one MPI/DP interface. The 317-2 DP and 319-3 PN/DP CPUs feature an MPI/DP interface plus an additional DP interface. The factory setting of the CPU's MPI/DP interface is MPI mode. You need to set DP mode in STEP 7 if you want to use the DP interface.

Operating modes for CPUs with two DP interfaces

Table 4- 14 Operating modes for CPUs with two DP interfaces

MPI/DP interface	PROFIBUS DP interface
<ul style="list-style-type: none"> • MPI • DP master • DP slave ¹ 	<ul style="list-style-type: none"> • not configured • DP master • DP slave ¹

¹ simultaneous operation of the DP slave on both interfaces is excluded

Properties

The PROFIBUS DP interface is mainly used to connect distributed I/O. PROFIBUS DP allows you to create large subnets, for example.

The PROFIBUS DP interface can be configured for operation in master or slave mode, and supports transmission rates up to 12 Mbps

The CPU broadcasts its bus parameters (transmission rate, for example) via the PROFIBUS DP interface when master mode is set. This functionality automatically provides the correct parameters for online operation of a programming device, for example. In your configuration you can specify to disable bus parameter broadcasting.

Note

(for DP interface in slave mode only)

When you disable the "Test, Commissioning, Routing" check box in the DP interface properties dialog box in STEP 7, the transmission rate settings of the master automatically override corresponding user-specific settings. This disables the routing function at this interface.

Devices capable of PROFIBUS DP communication

- PG/PC
- OP/TP
- DP slaves
- DP master
- Actuators/Sensors
- S7-300/S7-400 with PROFIBUS DP interface

Clock synchronization

Clock synchronization is possible via the CPU's PROFIBUS DP interface. Detailed information is available in the manual *CPU 31x and CPU 31x Manual, Technical specifications, Clock synchronization section*.

Reference

Additional information on the PROFIBUS can be found on the Internet.

4.11.2.5 Network components of MPI/DP and cable lengths

MPI subnet segment

You can install cables with a length of up to 50 m in an MPI subnet segment. This length of 50 m is the distance between the first and the last node of the segment.

Table 4- 15 Permissible cable length of a segment on the MPI subnet

Baud rate	S7-300 CPUs (non-isolated MPI interface) without CPU 314C-2 PN/DP, CPU 315-2 PN/DP, CPU 317, CPU 319	CPU 314C-2 PN/DP, CPU 315- PN/DP, CPU 317, CPU 319
19,2 kbit/s	50 m	1000 m
187,5 kbit/s		
1,5 Mbit/s	-	200 m
3,0 Mbit/s		100 m
6,0 Mbit/s		
12,0 Mbit/s		

Segment on the PROFIBUS subnet

The maximum cable length of a segment on the PROFIBUS subnet is determined by the set transmission rate.

Table 4- 16 Permissible cable length of a segment on the PROFIBUS subnet

Baud rate	Maximum cable length of a segment
9,6 kbit/s to 187.5 kbit/s	1000 m
500 kbit/s	400 m
1,5 Mbit/s	200 m
3 Mbit/s to 12 Mbit/s	100 m

Longer cable lengths via RS485 repeater/RS485 diagnostic repeater

You need to install RS485 repeaters for segments requiring cable lengths longer than the allowed length. For additional information about the RS485 Repeater refer to the *Module Specifications Manual*.

Stub cables

Make allowances for the maximum stub cable length when you connect bus nodes to a segment by means of stub cables, for example, a PG via standard PG cable.

For transmission rates up to 3 Mbit/s, you can use a PROFIBUS bus cable with bus connector as stub cable for connecting. For transmission rates of 3 Mbit/s and higher, use the PG patch cord to connect the PG or PC. You can connect several PG patch cords to the bus (for order numbers see table 4-20). Other types of stub cables are not permitted.

Length of stub cables

The table below shows the maximum permitted lengths of stub cables per segment:

Table 4- 17 Lengths of stub cables per segment

Baud rate	Max. length of stub cables per segment	Number of nodes with stub cable length of ...	
		1.5 m or 1.6 m	3 m
9,6 kbit/s to 93.75 kbit/s	96 m	32	32
187,5 kbit/s	75 m	32	25
500 kbit/s	30 m	20	10
1,5 Mbit/s	10 m	6	3
3 Mbit/s to 12 Mbit/s	¹	1	1

¹ To connect PGs or PCs for operation at transmission rates starting at 3 Mbit/s, use the PG patch cord with order number 6ES7901-4BD00-0XA0. In a bus configuration, you can use multiple PG patch cords with this order number. Other types of stub cables are not permitted.

PG connecting cable

Table 4- 18 PG connecting cable

Type	Order number
PG connecting cable	6ES7901-4BD00-0XA0

PROFIBUS cables

For PROFIBUS DP or MPI networking we offer you the following bus cables for diverse fields of application:

Table 4- 19 Available bus cables

Bus cable	Order number
PROFIBUS cable	6XV1830-0AH10
PROFIBUS cable, halogen-free	6XV1830-0LH10
PROFIBUS underground cable	6XV1830-3FH10
PROFIBUS trailing cable	6XV1830-3BH10
PROFIBUS cable with PUR sheath for environments subject to chemical and mechanical stress	6XV1830-0JH10
PROFIBUS cable with PE sheath for the food and beverages industry	6XV1830-0GH10
PROFIBUS cable for festooning	6XV1830-3GH10

Properties of PROFIBUS cables

The PROFIBUS bus cable is a 2-wire, shielded twisted pair cable with copper conductors. It is used for hardwired transmission in accordance with US Standard EIA RS485.

The table below lists the characteristics of these cables.

Table 4- 20 Properties of PROFIBUS cables

Properties	Values
Wave impedance	approx. 135 Ω to 160 Ω (f = 3 MHz to 20 MHz)
Loop resistance	\leq 115 Ω /km
Effective capacitance	30 nF/km
Attenuation	0.9 dB/100 m (f = 200 kHz)
Permitted conductor cross-sections	0.3 mm ² to 0.5 mm ²
Permitted cable diameter	8 mm \pm 0.5 mm

Installation of bus cables

When you install PROFIBUS bus cables, you must not

- twist,
- stretch
- or compress them.

When wiring indoor bus cables, also maintain the following marginal conditions (d_A = outer cable diameter):

Table 4- 21 Marginal conditions for wiring interior bus cables

Characteristics	Condition
Bending radius (one-off)	≥ 80 mm (10 x d_A)
Bending radius (multiple times)	≥ 160 mm (20 x d_A)
Permitted temperature range during installation	-5 °C to +50 °C
Shelf and static operating temperature range	-30 °C to +65 °C

Reference

For information on the use of fiber-optic cables for PROFIBUS, refer to the SIMATIC NET, PROFIBUS Networks Manual.

Bus connector RS 485

Table 4- 22 Bus connector

Type	Order number
Bus connector RS 485 up to 12 Mbit/s with 90° cable exit without programming device interface with programming device interface	6ES7972-0BA12-0XA0 6ES7972-0BB12-0XA0
Fast connect bus connector RS 485 up to 12 Mbit/s with 90° cable outlet in insulation displacement method without programming device interface with programming device interface	6ES7972-0BA51-0XA0 6ES7972-0BB51-0XA0
Bus connector RS 485 up to 12 Mbit/s with 35° cable outlet (not for CPU 31xC, 312, 314 and 315-2 DP) without programming device interface with programming device interface	6ES7972-0BA41-0XA0 6ES7972-0BB41-0XA0

Field of application

You need bus connectors to connect the PROFIBUS bus cable to an MPI or PROFIBUS-DP interface.

You do not require a bus connector for:

- DP slaves with degree of protection IP 65 (ET 200pro, for example)
- RS 485 repeater

RS 485 repeater

Type	Order number
RS 485 repeater	6ES7972-0AA01-0XA0
RS 485 Diagnostic Repeater	6ES7972-0AB01-0XA0

Note

SFC 103 "DP_TOPOL" can be used to initiate identification of the bus topology of a DP master system by way of the interconnected diagnostic repeaters.

Purpose

RS485 repeaters are used to amplify data signals on bus lines and to couple bus segments.

You require an RS 485 Repeater in the following situations:

- more than 32 network nodes
- when interconnecting a grounded with an ungrounded segment
- when exceeding the maximum line length in a segment

Longer cable lengths

If you want to implement cable lengths above those permitted in a segment, you must use RS485 repeaters. The maximum cable lengths between two RS 485 repeaters correspond to the maximum cable length of a segment. Please note that these maximum cable lengths only apply if there is no additional node interconnected between the two RS 485 repeaters. You can connect up to nine RS 485 repeaters in series. Note that you have to include the RS 485 repeater when counting the number of subnet nodes, regardless of whether or not it was assigned its own MPI/PROFIBUS address.

Reference

For additional information about the RS485 Repeater, refer to the *Module Specifications Manual*.

4.11.2.6 Cable lengths of MPI and PROFIBUS subnets

Example: Installation of an MPI subnet

The figure below shows you the block diagram of a MPI subnet.

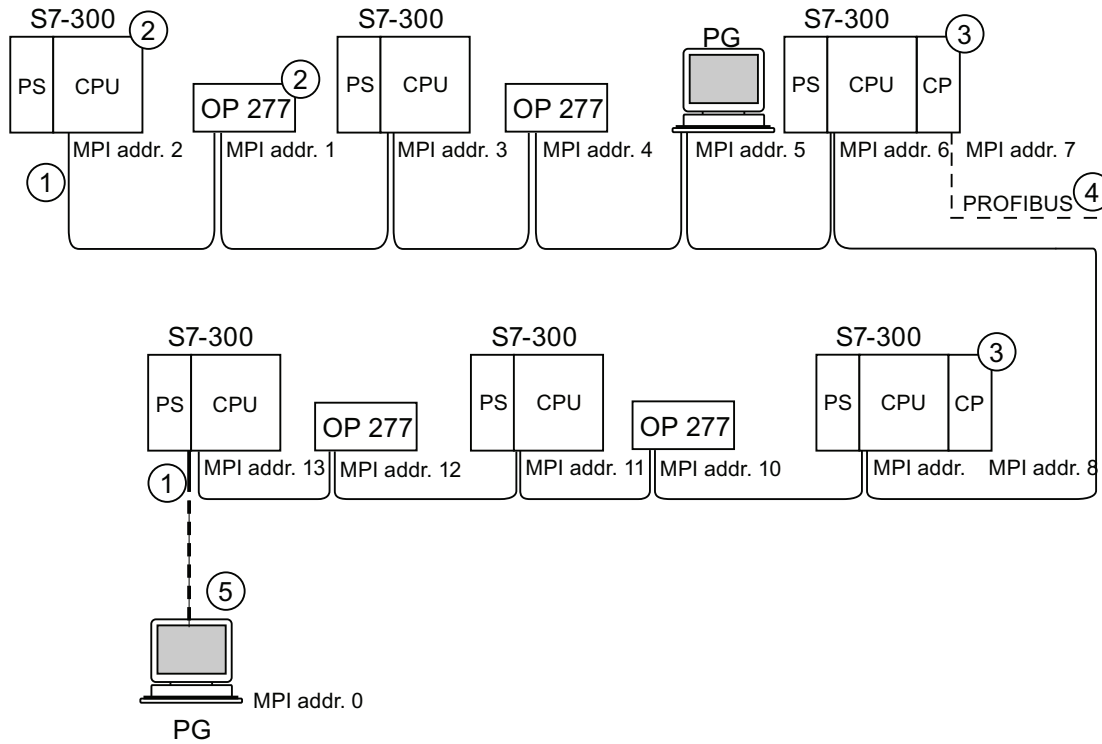

- | Number | Description |
|--------|---|
| ① | Terminating resistor enabled. |
| ② | S7-300 and OP 277 have subsequently been connected to the MPI subnet using their default MPI address. |
| ③ | CPU 31xC (except CPU 314C-2 PN/DP), 312, 314, CPU 315-2 DP:
You can freely assign the MPI addresses of the CPs/FMs with these CPUs.
CPU 314C-2 PN/DP, CPU 317-2 DP, 315-2 PN/DP, 317-2 PN/DP, 319-3 PN/DP:
CPs or FMs do not have their own MPI address with these CPUs. |
| ④ | In addition to the MPI address, the CP also has a PROFIBUS address (7 in this case). |
| ⑤ | Connected via stub cable using the default MPI address only for commissioning/maintenance. |

Example: Maximum distances in the MPI subnet

The figure below shows you:

- a possible MPI subnet configuration
- maximum distances possible in an MPI subnet
- the principle of "Line extension" using RS 485 repeaters

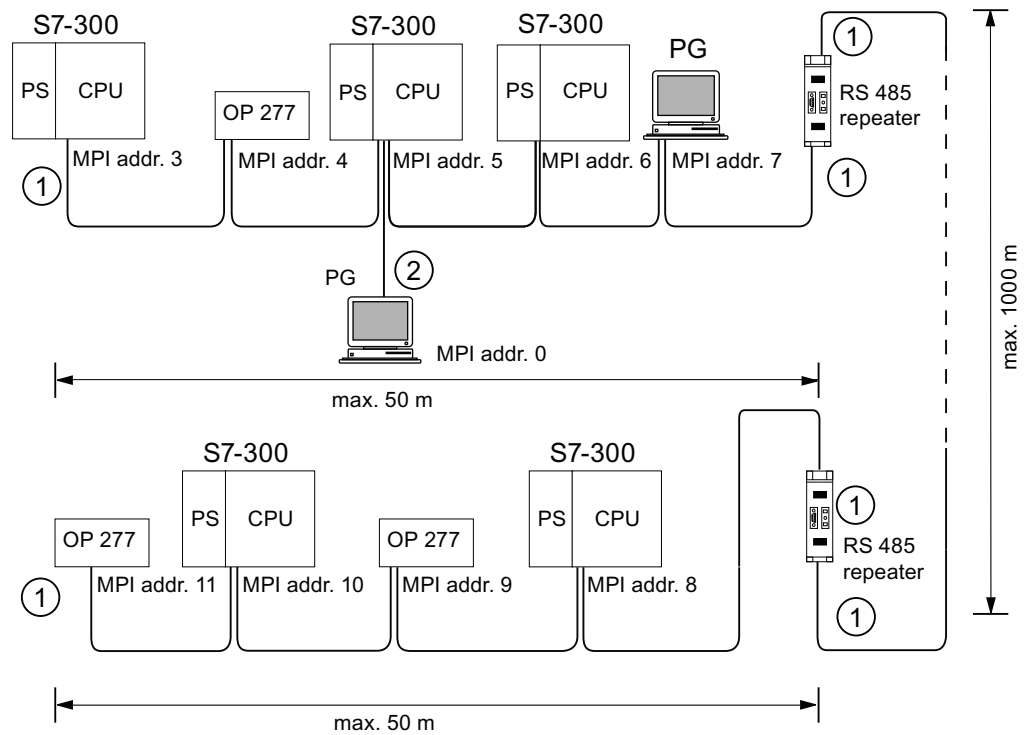

Number	Description
①	Terminating resistor enabled
②	PG connected by means of stub cable for maintenance purposes

Example: Terminating resistor in the MPI subnet

The figure below shows you an example of an MPI subnet and where to enable the terminating resistor.

The figure below illustrates where the terminating resistors must be enabled in an MPI subnet. In this example, the programming device is connected via a stub cable only for the duration of commissioning or maintenance.

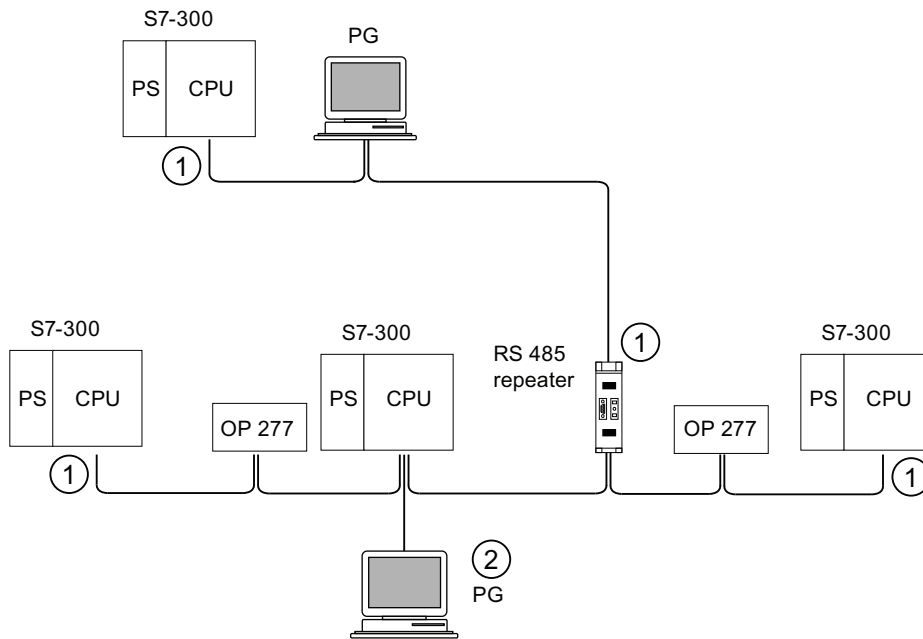

Number	Description
①	Terminating resistor enabled
②	PG connected by means of stub cable for maintenance purposes

⚠ WARNING

Disturbance of data traffic might occur on the bus. A bus segment must always be terminated at both ends with the terminating resistor. This, for example, is not the case if the last slave with bus connector is off power. The bus connector draws its power from the station, and the terminating resistor is thus disabled. Please make sure that power is always supplied to stations on which the terminating resistor is active. Alternatively, the PROFIBUS terminator can also be used as active bus termination.

Example: Installation of a PROFIBUS subnet

The figure below shows you the basic principles of a PROFIBUS subnet installation.

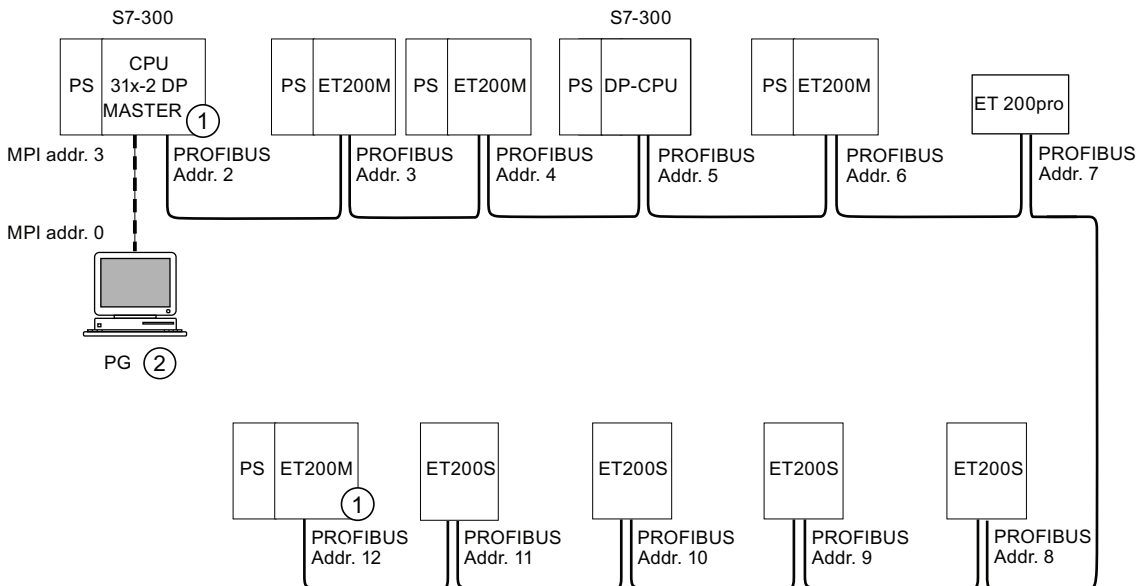

Number Description

- ① Terminating resistor enabled
- ② PG connected by means of stub cable for maintenance purposes

Example: CPU 314C-2 DP as MPI and PROFIBUS node

The figure below shows you an assembly with a CPU 314C-2 DP integrated in an MPI subnet and also operated as DP master in a PROFIBUS subnet.

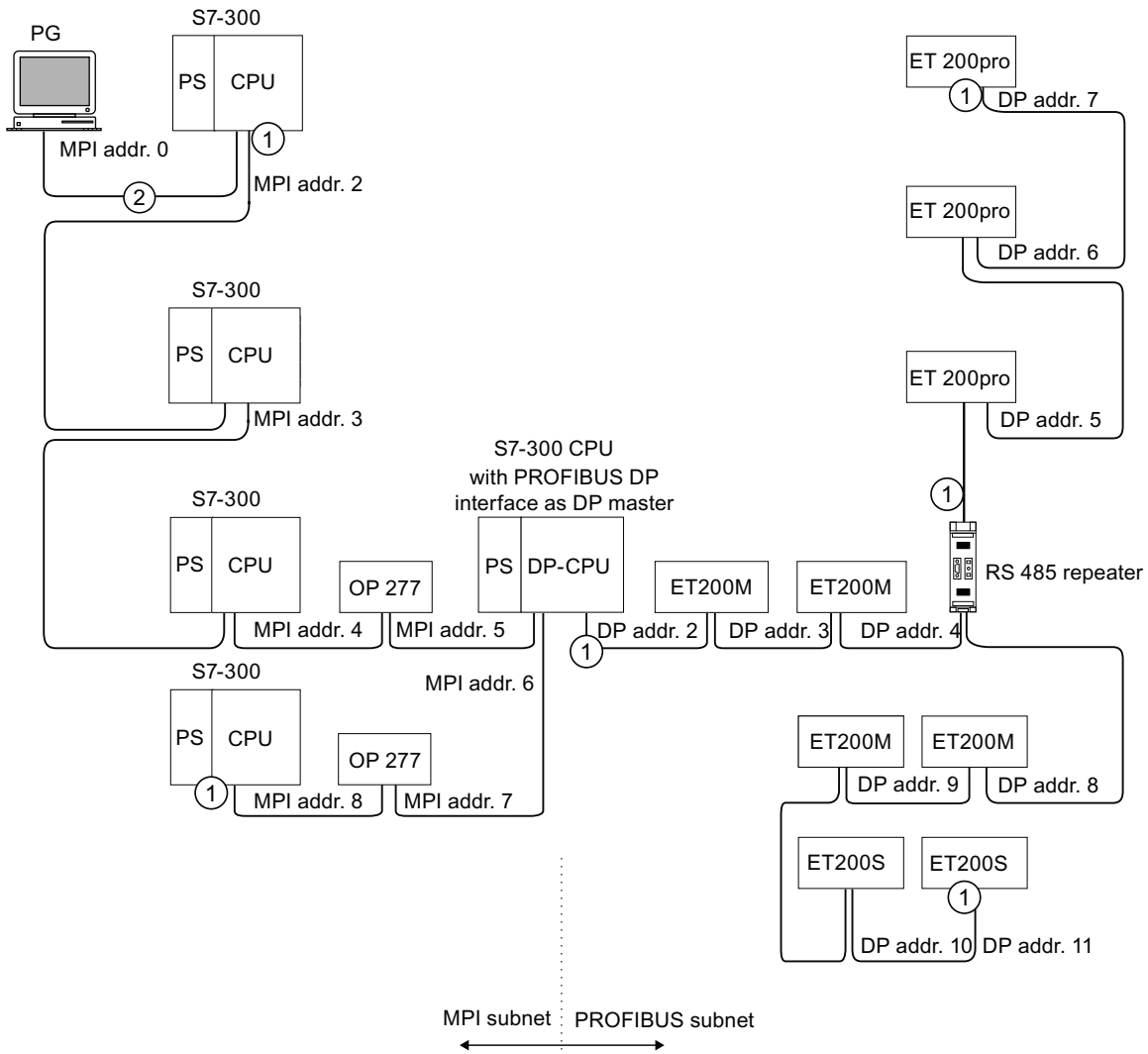

Number	Description
①	Terminating resistor enabled
②	PG connected via a stub cable for maintenance or commissioning purposes

4.11.3 Configuring PROFINET subnets

4.11.3.1 Overview

The next section contains all the information you require to configure PROFINET subnets:

Contents

- PROFINET devices
- Integration of field bus system into PROFINET
- PROFINET IO and PROFINET CBA (Component-Based Automation)
- PROFINET cable lengths
- Ethernet bus cable and connector
- Example of a PROFINET subnet
- Example of a PROFINET IO system

4.11.3.2 PROFINET devices

Definition: Devices in the PROFINET environment

Within the context of PROFINET, "device" is the generic term for:

- Automation systems (e.g. PLC, PC)
- Field devices (for example, PLC, PC, hydraulic devices, pneumatic devices)
- Active network components (for example, switches, gateways, routers)
- PROFIBUS or other fieldbus systems

The main characteristic of a device is its integration into PROFINET communication by means of Ethernet or PROFIBUS.

The following device types are distinguished based on their attachment to the bus:

- PROFINET devices
- PROFIBUS devices

Definition: PROFINET devices

A PROFINET device always has at least one Industrial Ethernet port. A PROFINET device can also be operated as proxy to act as representative that safeguards Ethernet communication between PROFIBUS devices (PROFIBUS slaves connected to an existing PROFIBUS interface) and additional PROFINET devices on the Ethernet.

Definition: PROFIBUS devices

A PROFIBUS device has at least one PROFIBUS link with an electric interface (RS485) or an optical interface (polymer optical fiber, POF).

A PROFIBUS device cannot take part directly in PROFINET communication, but must be implemented by means of PROFIBUS master with PROFINET link or Industrial Ethernet/PROFIBUS link (IE/PB Link) with proxy functionality.

Comparison of the terminology in PROFIBUS DP and PROFINET IO

The following schematic shows you the general names of the most important devices in PROFINET IO and PROFIBUS DP. The table below shows the designation of the various components in the PROFINET IO and PROFIBUS DP context.

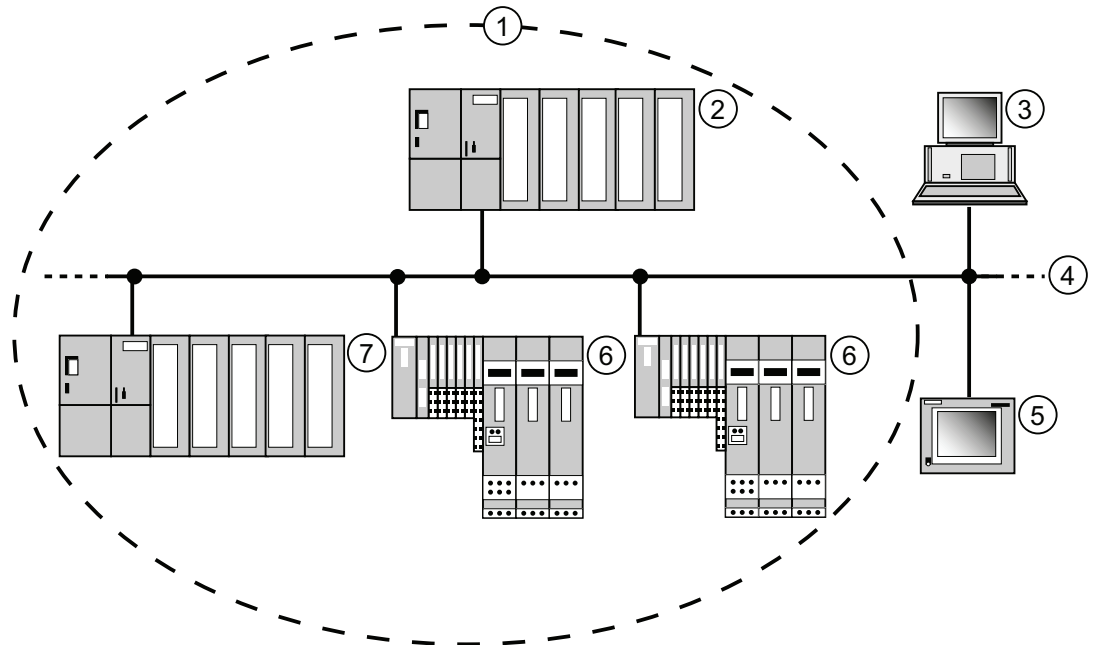

Number	PROFINET	PROFIBUS	Remark
①	IO system	DP master system	
②	IO controller	DP master	Device used to address the connected IO devices/DP slaves. That is: The IO controller/DP master exchanges input and output signals with field devices. The IO controller/DP master is often the controller on which the automation program runs.
③	PG/PC (IO supervisor)	PG/PC (Class 2 DP master)	PG/PC/HMI device for commissioning and diagnostics
④	Industrial Ethernet	PROFIBUS	Network infrastructure
⑤	HMI (Human Machine Interface)	HMI	Device for operating and monitoring functions
⑥	IO device	DP slave	Distributed field device assigned to one of the IO controllers/DP masters, for example, distributed IO, valve terminal, frequency converter, and switches with integrated PROFINET IO functionality.
⑦	I device	Intelligent slave	Intelligent field device that can be configured as I-device/I-slave

Figure 4-3 PROFINET and PROFIBUS devices

Slots and Submodules

A PROFINET IO device is modularly structured - similar to a PROFIBUS DP slave.

In doing so, modules are fitted to slots and submodules to subslots. Channels are located on the modules / submodules using which process signals can be read in and issued.

The following graphic illustrates the situation.

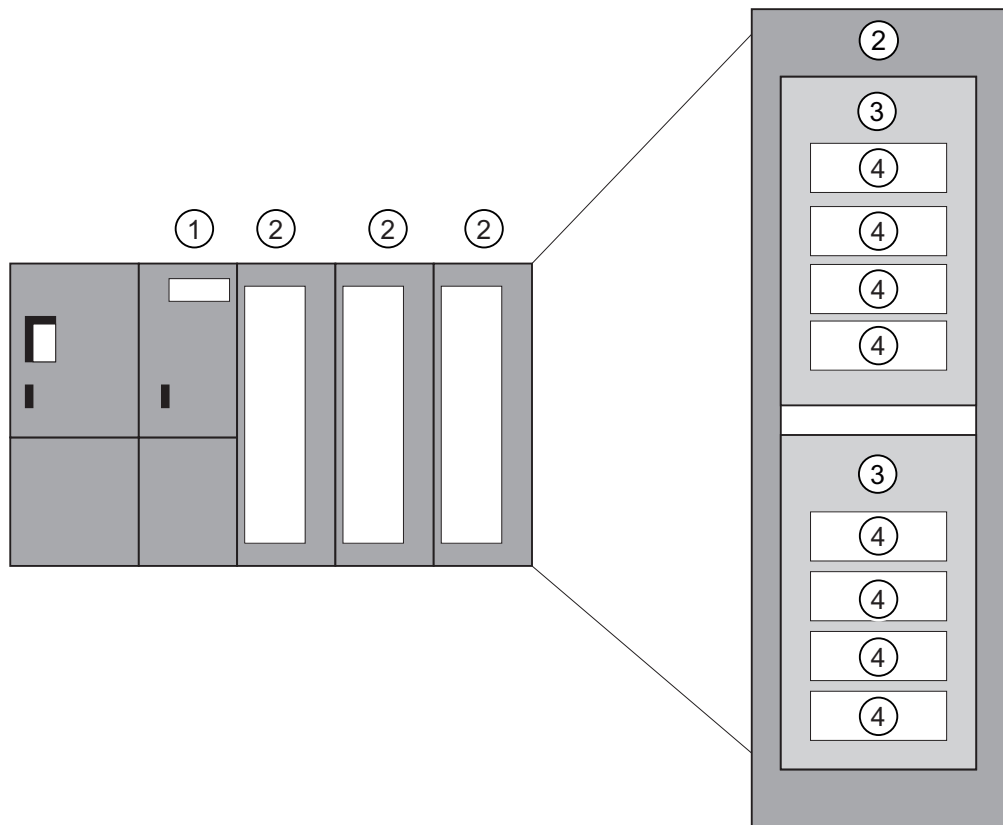

Figure 4-4 Module, Submodule, Slot, and Channel

Number	Description
①	Interface module
②	Module with components
③	Submodule
④	Channel

In principle it is possible to divide a slot into additional subslots on which the submodules are connected.

4.11.3.3 Integration of fieldbuses into PROFINET

Fieldbus integration

PROFINET allows you to use a proxy to integrate existing fieldbus systems (for example, PROFIBUS, ASI) into PROFINET. In this way, you can set up hybrid systems consisting of fieldbus and Ethernet-based subsystems. A continuous technological transition to PROFINET is thus possible.

Interconnecting PROFINET and PROFIBUS

You can interconnect PROFIBUS devices to the local PROFIBUS interface of a PROFINET device. This allows you to integrate existing PROFIBUS configurations in PROFINET.

The following picture illustrates the network types that are supported for PROFINET:

- Industrial Ethernet and
- PROFIBUS.

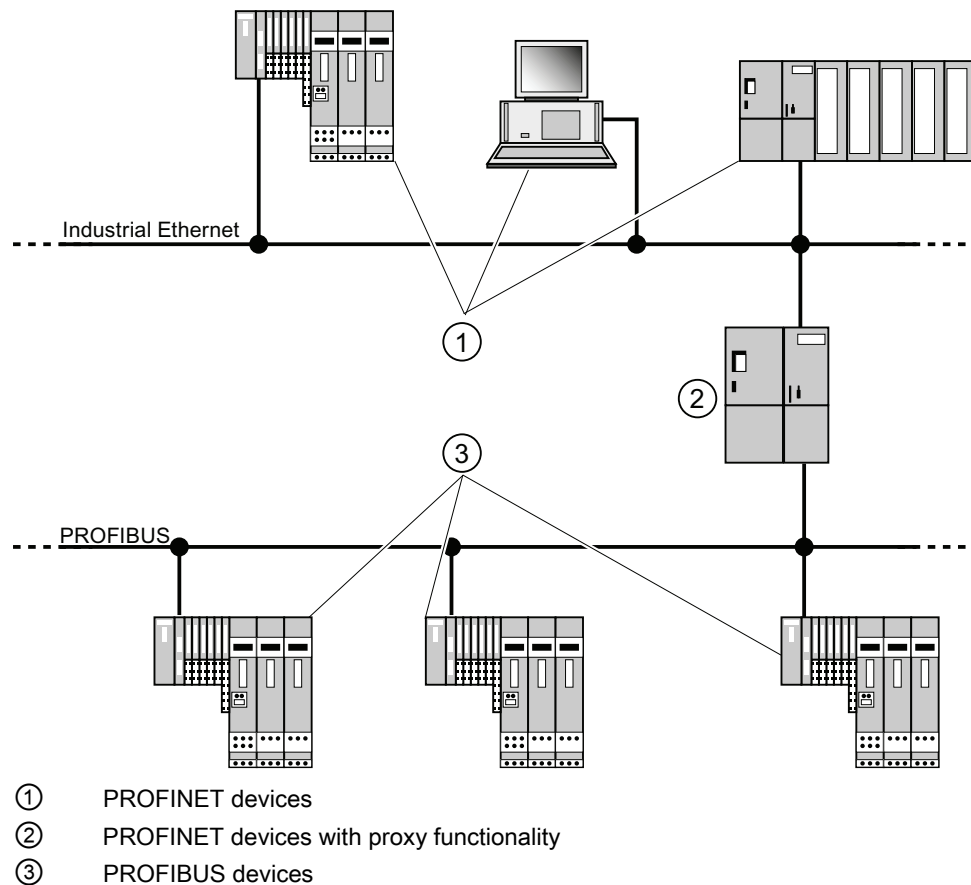

PROFINET device with proxy functionality = substitute

The PROFINET device with proxy functionality is the substitute for a PROFIBUS device on Ethernet. The proxy functionality allows a PROFIBUS device to communicate not only with its master but also with all nodes on PROFINET.

With PROFINET, existing PROFIBUS systems can be integrated into the PROFINET communication with the aid of an IE/PB link, for example. The IE/PB link then handles communication via PROFINET on behalf of the PROFIBUS components.

In this way, you can link both DPV0 and DPV1 slaves to PROFINET.

Additional information

For information on the differences and common features of PROFINET IO and PROFIBUS DP and information on migrating from PROFIBUS DP to PROFIBUS IO, refer to the *From PROFIBUS DP to PROFINET IO* programming manual.

4.11.3.4 PROFINET IO and PROFINET CBA

What is PROFINET IO?

As part of PROFINET, PROFINET IO is a communication concept that is used to implement modular, distributed applications.

PROFINET IO allows you to create automation solutions, which are familiar to you from PROFIBUS.

PROFINET IO is implemented using the PROFINET standard for programmable controllers.

The STEP 7 engineering tool helps you to structure and configure an automation solution.

In STEP 7 you have the same application view, regardless of whether you are configuring PROFINET devices or PROFIBUS devices. Program your user program in the same way for both PROFINET IO and PROFIBUS DP, since you will use the extended blocks and system status lists for PROFINET IO.

Reference

Information on new and modified blocks and system status lists can be found in the *From PROFIBUS DP to PROFINET IO* programming manual.

What is PROFINET CBA?

As part of PROFINET, PROFINET CBA (Component Based Automation) is an automation concept that focuses on the following:

- Implementation of modular applications
- Machine - machine communication

PROFINET CBA lets you create distributed automation solutions, based on default components and partial solutions. This concept meets the demand for a greater modularity in the field of mechanical and systems engineering by extensive distribution of intelligent processes.

With Component Based Automation you can implement complete technological modules as standardized components that can be used in large systems.

You create the modular, intelligent components of the PROFINET CBA in an engineering tool (which may differ according to the device manufacturer). Components that are formed from SIMATIC devices are created with STEP 7, and are interconnected using the SIMATIC iMAP tool.

Interaction between PROFINET IO and PROFINET CBA

PROFINET CBA is used to integrate PROFINET IO systems into machine-to-machine communication. A PROFINET component is created from a PROFINET IO system in STEP 7, for example. With SIMATIC iMap, you can configure systems consisting of several such components. The communication connections between the devices are configured simply as interconnection lines.

The following graphic illustrates a distributed automation solution with several components which communicate via PROFINET. The components on the right have IO devices and an IO controller on PROFINET IO.

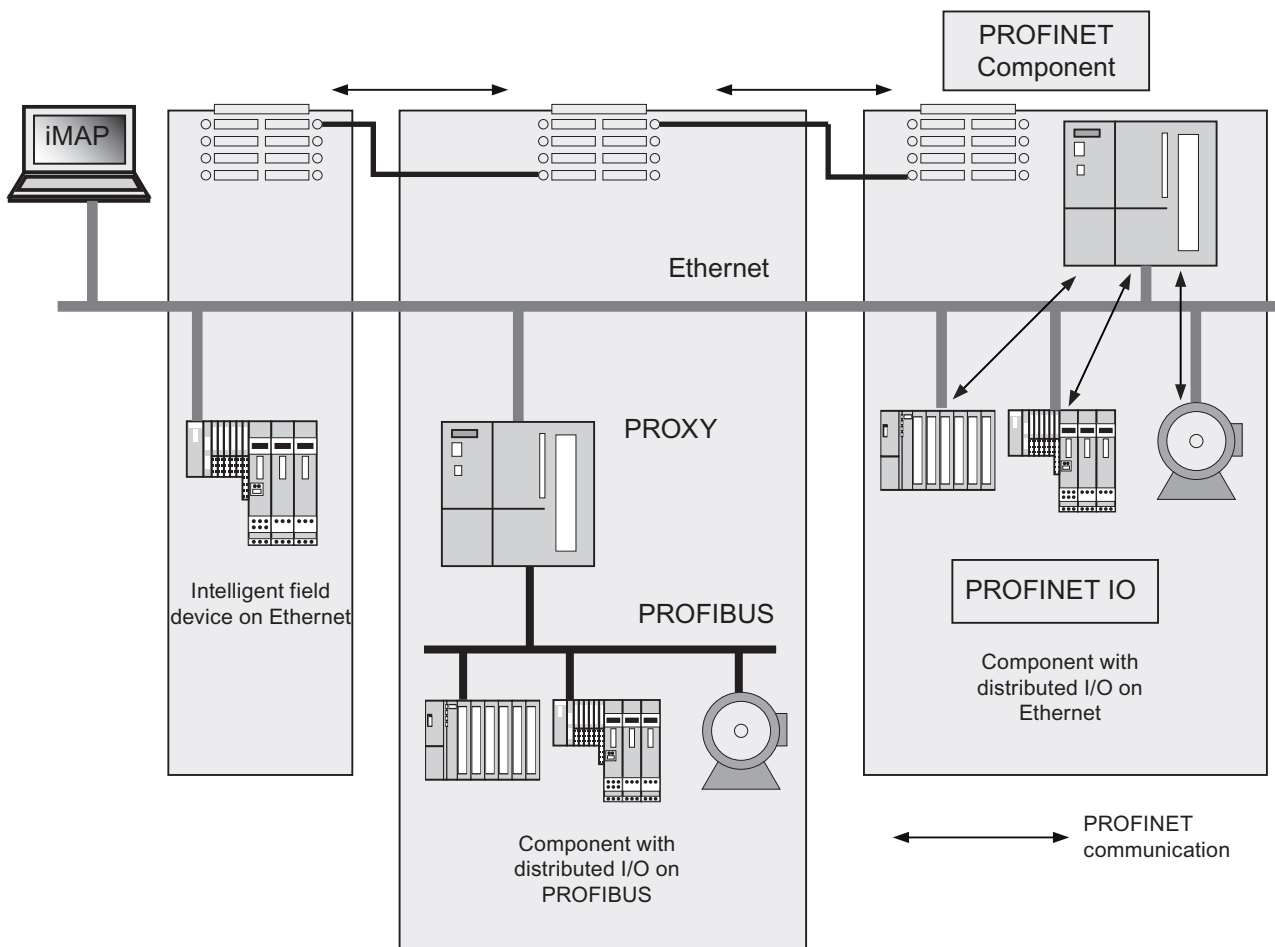

Figure 4-5 PROFINET CBA - modular concept

Extent of PROFINET CBA and PROFINET IO

PROFINET IO and CBA represent two different views of automation devices on Industrial Ethernet.

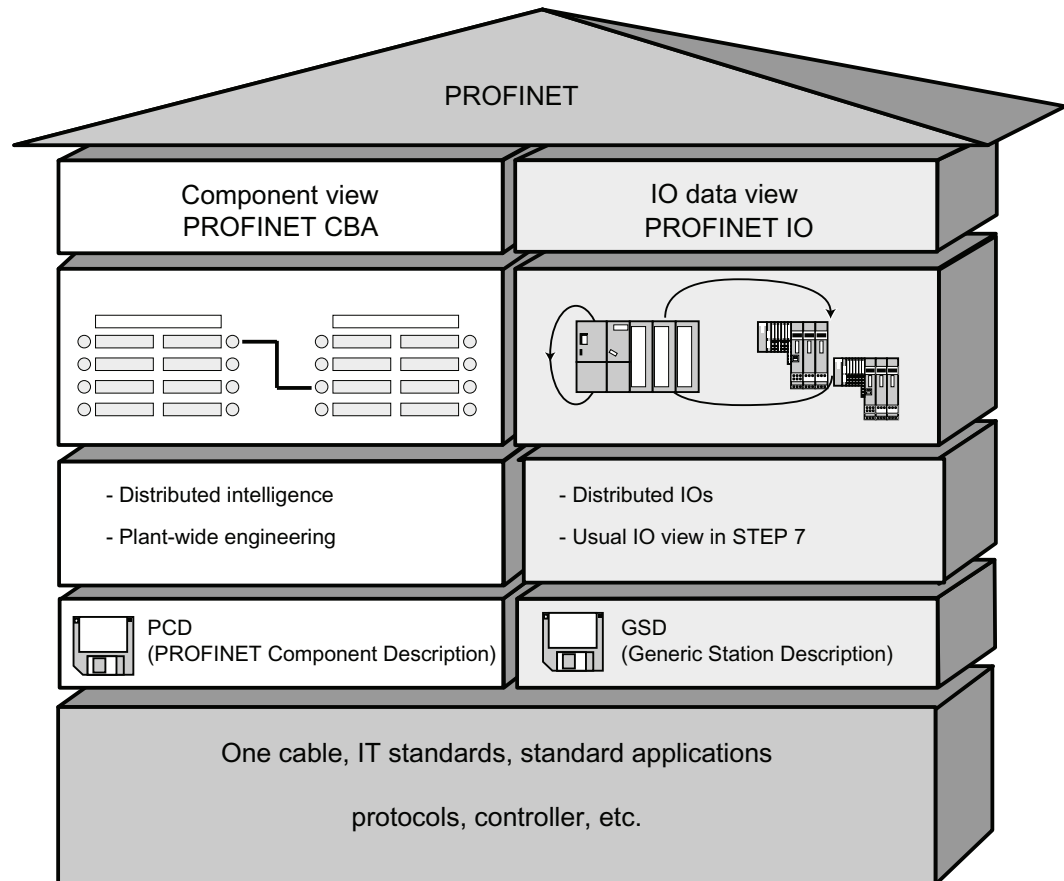

Figure 4-6 Extent of PROFINET CBA and PROFINET IO

Component Based Automation divides the entire system into various functions. These functions are configured and programmed.

PROFINET IO provides an image of the system that is very similar to the view obtained in PROFIBUS. You continue to configure and program the individual automation devices.

Controllers in PROFINET IO and PROFINET CBA

You can also use some PROFINET IO controllers for PROFINET CBA.

The following PROFINET devices can act as a **PROFINET CBA and IO controller**:

- Programmable logic controllers,
 - S7-300 CPU 31x-2 PN/DP, firmware version V2.3 or later
 - S7-300 CPU 314C-2 PN/DP, firmware version V3.3 or later
 - S7-300 CPU 319-3 PN/DP, firmware version V2.4.0 or later
- CP 343-1 - as of version 6GK7343-1EX21-0XE0 and 6GK7343-1GX21-0XE0
- CP 443-1 Advanced with MLFB 6GK7443-1EX40 as of version V2.1 and 6GK7443-1EX41 as of version V1.0.

The following PROFINET devices can only act as a **PROFINET IO controller**:

- PCs that are linked to a PROFINET IO-compatible CP (CP 1616 for example) or via SOFTNET PN IO (with CP 1612 for example). With the CP 1616 and SOFTNET PN IO, the user program runs in the CPU of the PC.
- SIMOTION devices for particularly stringent real-time requirements.

Some PROFINET devices can only be used as **PROFINET CBA controllers**, for example, PCs with standard Ethernet interfaces and the WinLC software.

- CP443-1 EX 40 V2.1 or later or CP443-1 EX41 V 1.0 or later

Proxy in PROFINET IO and PROFINET CBA

The proxies for PROFINET IO and proxies for PROFINET CBA are different.

In PROFINET IO, the proxy for PROFINET IO represents each connected PROFIBUS DP slave as a **PROFINET IO device** on the PROFINET.

In PROFINET CBA, the proxy for PROFINET CBA represents every connected PROFIBUS DP slave as one **component**, which can participate in PROFINET communication.

There are thus different IE/PB links for PROFINET IO and PROFINET CBA, for example. At present, you can only use a CPU 31x PN/DP as a proxy for PROFINET CBA.

Linking PROFIBUS devices via an IE/PB link

Please note that proxy functionality is available in both PROFINET IO and PROFINET CBA. For the IE/PB link, this means that you must use different devices depending on the system you are using.

Configuring and integrating components and devices in PROFINET communication

In component based automation, an interconnection editor is used to incorporate the components (SIMATIC iMap, for example). The components are described in a PCD file.

With PROFINET IO, the devices are incorporated using an engineering system (STEP 7, for example). The devices are described in a GSD file.

Interaction between PROFINET CBA and PROFINET IO

PROFINET IO integrates field devices (IO devices) into PROFINET. The input and output data of the IO devices are processed in the user program. The IO devices with their IO controller can, in turn, be part of a component in a distributed automation structure.

Communication between a CPU as the IO controller and the assigned IO devices as PROFINET IOs is configured in the same way as for a PROFIBUS DP master system in STEP 7. The user program is also created in STEP 7. From the entire PN IO system, you create a component in STEP 7 (see Figure PROFINET CBA).

You then configure communication between the components in user-friendly SIMATIC iMAP.

Update time

The IO controller (outputs) provides new data to all IO devices in the PROFINET IO system within the update time. This means that all the IO devices have sent their latest data to the IO controller (inputs).

Note

Send Cycles for Cyclical Data Exchange

STEP 7 determines the update time on the basis of the existing hardware configuration and the resulting cyclical data traffic. During this time, a PROFINET IO device has exchanged its user data with the associated IO controller.

You can set the update date either for a whole bus segment of an IO controller, or for an individual IO device.

In STEP 7, the update time can be changed manually.

The smallest possible update time in a PROFINET system depends on the following factors:

- Number of PROFINET IO devices
- Quantity of configured user data
- PROFINET IO communication allocation (compared to PROFINET CBA communication allocation)

Additional cyclical PROFINET services

The update time dialog in STEP 7/HW Config is used to set an update date for the device to be reserved for PROFINET IO.

See the STEP 7 Online Help for more information.

Send cycle

Period between two successive intervals for IRT or RT communication. The send cycle is the shortest possible transmit interval for exchanging data. The calculated update times are multiples of the send cycle.

The minimum possible update time thus depends on the minimum send cycle of the IO controller that can be set.

If both the IO controller and the IO device support a send cycle of 250 µs, you can achieve a minimum update time of 250 µs.

It is also possible to operate IO devices that only support a send cycle of 1 ms on an IO controller that works with a send cycle of 250 µs. The minimum update time for the IO devices concerned is then at least 1 ms, however.

Update times for CPU 31x PN/DP

The following update times can be parameterized:

Real-time communication	Send cycle	Update time
With RT:	250 µs	⇒ 250 µs to 128 ms
	500 µs	⇒ 500 µs to 256 ms
	1 ms	⇒ 1 ms to 512 ms
	2 ms	⇒ 2 ms to 512 ms
	4 ms	⇒ 4 ms to 512 ms
For IRT with the "high flexibility" option:	250 µs	⇒ 250 µs to 128 ms
	500 µs	⇒ 500 µs to 256 ms
	1 ms	⇒ 1 ms to 512 ms
For IRT with the "high performance" option:	250 µs	⇒ 250 µs to 4 ms
	500 µs	⇒ 500 µs to 8 ms
	1 ms	⇒ 1 ms to 16 ms
	2 ms	⇒ 2 ms to 32 ms
	4 ms	⇒ 4 ms to 64 ms

The minimum update time is determined by the number of devices used, by the volume of configured user data, and by the time slice for PROFINET IO communication. *STEP 7* automatically considers these dependencies during configuration.

Send cycles with odd values for IRT with the "high performance" option:

In addition to the "even value" send cycles (250 μ s, 500 μ s, 1 ms, 2 ms, 4 ms) in the range from 250 μ s to 4 ms, you can set up any multiple of 125 μ s as "odd value" send cycle for IRT with the "high performance" option: 375 μ s, 625 μ s ... 3.875 ms.

Rule for all PROFINET IO devices operating with "odd value" send cycles:

- Update time = send cycle
- It is not possible to complement IRT with the "high performance" through RT devices

Details of the possible uses of the individual products

See also the documentation for the product concerned.

4.11.3.5 PROFINET cable lengths and network expansion

Network expansion options are based on various factors (hardware design used, signal propagation delay, minimum distance between data packets, etc.)

Twisted pair cables

Twisted pair cables are used to interconnect terminal devices with the Industrial Ethernet FC cabling system. It is designed for use in environments with low EMC load, for example, in offices or in control cabinets.

The length of twisted pair cables between two devices may not exceed 10 m.

Compared to Industrial Ethernet twisted pair cables, the twisted pair cables are significantly thinner and more flexible due to the reduced effort for their shielding. The connectors used in connecting industrial twisted pair components are standardized RJ45 connectors and sub D connectors.

Product range

The following twisted pair cables are available:

Table 4- 23 Data for ready-made twisted pair cables

Cable designation	Application	Available lengths	Order number
TP Cord RJ45/RJ45	TP connecting cable with two RJ45 connectors	0.5 m 1.0 m 2.0 m 6.0 m 10.0 m	6XV1850-2GE50 6XV1850-2GH10 6XV1850-2GH20 6XV1850-2GH60 6XV1850-2GN10
TP XP cord RJ45/RJ45	TP crossover cable with two RJ45 connectors	0.5 m 1.0 m 2.0 m 6.0 m 10.0 m	6XV1850-2HE50 6XV1850-2HH10 6XV1850-2HH20 6XV1850-2HH60 6XV1850-2HN10
TP cord 9/RJ45	TP cable with 9-pin sub-D connector and RJ45 connector	0.5 m 1.0 m 2.0 m 6.0 m 10.0 m	6XV1850-2JE50 6XV1850-2JH10 6XV1850-2JH20 6XV1850-2JH60 6XV1850-2JN10
TP XP cord 9/RJ45	Crossover TP cable with 9-pin sub-D connector and RJ45 connector	0.5 m 1.0 m 2.0 m 6.0 m 10.0 m	6XV1850-2ME50 6XV1850-2MH10 6XV1850-2MH20 6XV1850-2MH60 6XV1850-2MN10
TP patch cable 9-45/RJ45	TP cable with RJ45 connector and sub-D connector, 45° cable exit (for OSM/ESM only)	1.0 m	6XV1850-2NH10
TP XP patch cable 9-45/RJ45	Crossover TP cable with RJ45 connector and sub-D connector with 45° cable exit (for OSM/ESM only)	1.0 m	6XV1850-2PH10
TP XP patch cable 9/9	Crossover TP cable for direct interconnection of two industrial Ethernet network components with ITP interface, with two 9-pin sub-D connectors	1.0 m	6XV1850-2RH10
TP cord RJ45/15	TP cable with 15-pin sub-D connector and RJ45 connector	0.5 m 1.0 m 2.0 m 6.0 m 10.0 m	6XV1850-2LE50 6XV1850-2LH10 6XV1850-2LH20 6XV1850-2LH60 6XV1850-2LNN10
TP XP patch cable RJ45/15	Crossover TP cable with 15-pin sub-D connector and RJ45 connector	0.5 m 1.0 m 2.0 m 6.0 m 10.0 m	6XV1850-2SE50 6XV1850-2SH10 6XV1850-2SH20 6XV1850-2SH60 6XV1850-2SN10

Industrial Ethernet Fast Connect twisted pair cables

The Fast Connect twisted pair cabling system is ideal for structured cabling in the production hall. FastConnect cables allow for the quick and easy on-site assembly of patch cables. The RJ45 cabling technology is the existing standard and is also available as an industrial version which allows structured cabling.

Product range

Industrial Ethernet Fast Connect twisted pair cables available:

Table 4- 24 Data for user assemblies using patch cables of the Fast Connect product family

Cable designation	Application	Available lengths	Order number
SIMATIC NET IE FC RJ 45 PLUG 145	RJ45 connector for Industrial Ethernet with rugged metal housing and four integrated insulation displacement terminals for connecting Industrial Ethernet FC installation cables; 145° cable outlet.	1 piece	6GK1901-1BB30-0AA0
		10 items	6GK1901-1BB30-0AB0
		50 items	6GK1901-1BB30-0AE0
SIMATIC NET IE FC RJ 45 PLUG 180	RJ45 connector for Industrial Ethernet with rugged metal housing and four integrated insulation displacement terminals for connecting Industrial Ethernet FC installation cables; 180° cable outlet.	1 piece	6GK1901-1BB10-2AA0
		10 items	6GK1901-1BB10-2AB0
		50 items	6GK1901-1BB10-2AE0

Reference

Detailed information is available in the

- SIMATIC NET Manual: Twisted-pair and fiber-optic networks (6GK1970-1BA10-0AA0)
- Internet under Service & Support (<http://www.siemens.com/automation/service&support>)
- Catalog IK PI, SIMATIC NET (E86060-K6710-A101-B5)

See also

Connecting the PG to a node (Page 156)

Connecting the PG to several nodes (Page 157)

4.11.3.6 Connectors and other components for Ethernet

The selection of the bus cable, bus connector and other components for Ethernet (for example, switches, etc.) depends on the intended application.

We offer a range of products covering a variety of applications for the installation of an Ethernet connection.

Reference

- SIMATIC NET: Twisted-pair and fiber-optic networks (6GK1970-1BA10-0AA0)

4.11.3.7 Example of a PROFINET subnet

Example: Installation of a PROFINET subnet

The graphic illustrates the combination of corporate level and process control level via industrial Ethernet. PCs in a classical office environment can be used to acquire data of the process automation system.

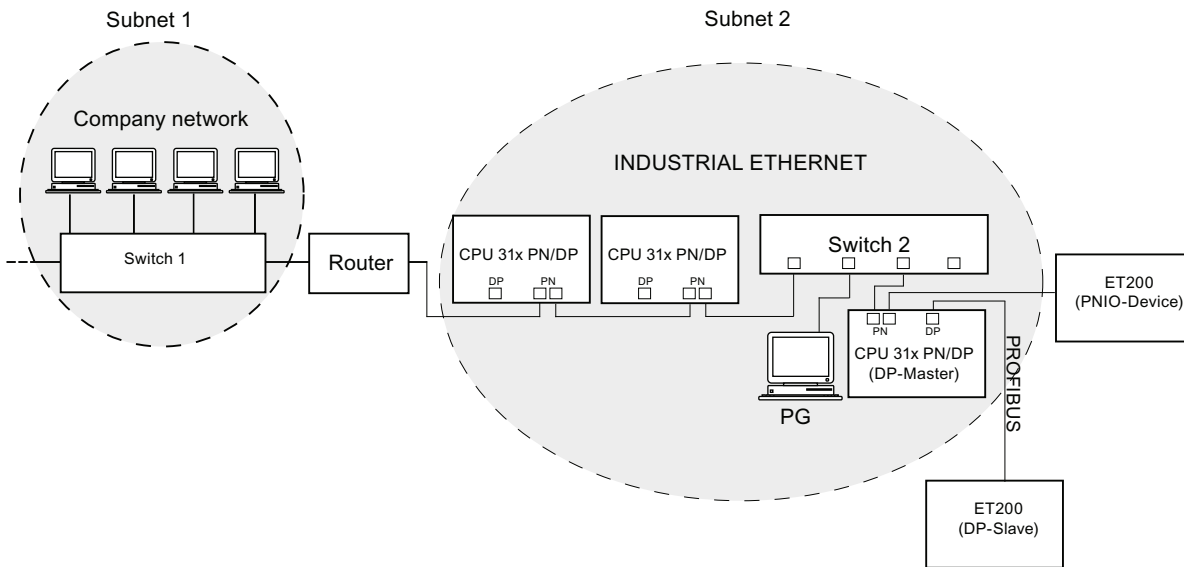

Figure 4-7 Example of a PROFINET subnet

Installation guidelines

PROFINET allows you to set up a high-performance and continuous communication system. You can additionally increase performance by using the following installation guidelines.

- Interconnect a router between the office network and the PROFINET system. Use the router to define access privileges for your PROFINET system.
- Where practical, set up your PROFINET system in a star architecture (for example, in the control cabinet).
- Keep the number of switches low. This increases clarity of your PROFINET system architecture.
- Connect your programming device (PG) close to the communication partner (for example, programming device and communication partner on the same switch).
- Modules with PROFINET interfaces may only be operated in LANs where all nodes are equipped with SELV/PELV power supplies or protection systems of equal quality.
- A data transfer device that ensures this safety must be specified for the coupling to the WAN.

Reference

For detailed information on Industrial Ethernet networks or network components, refer to:

- the Internet URL <http://www.siemens.com/automation/service&support>.
- The STEP 7 Online Help. There you can also find additional information on IP address assignment.
- The Communication with SIMATIC (EWA 4NEB 710 6075-01) manual
- In the SIMATIC NET Twisted-Pair and Fiber-Optic Networks (6GK1970-1BA10-0AA0) manual

4.11.3.8 PROFINET IO System

Functions of PROFINET IO

The following graphic shows the new functions in PROFINET IO:

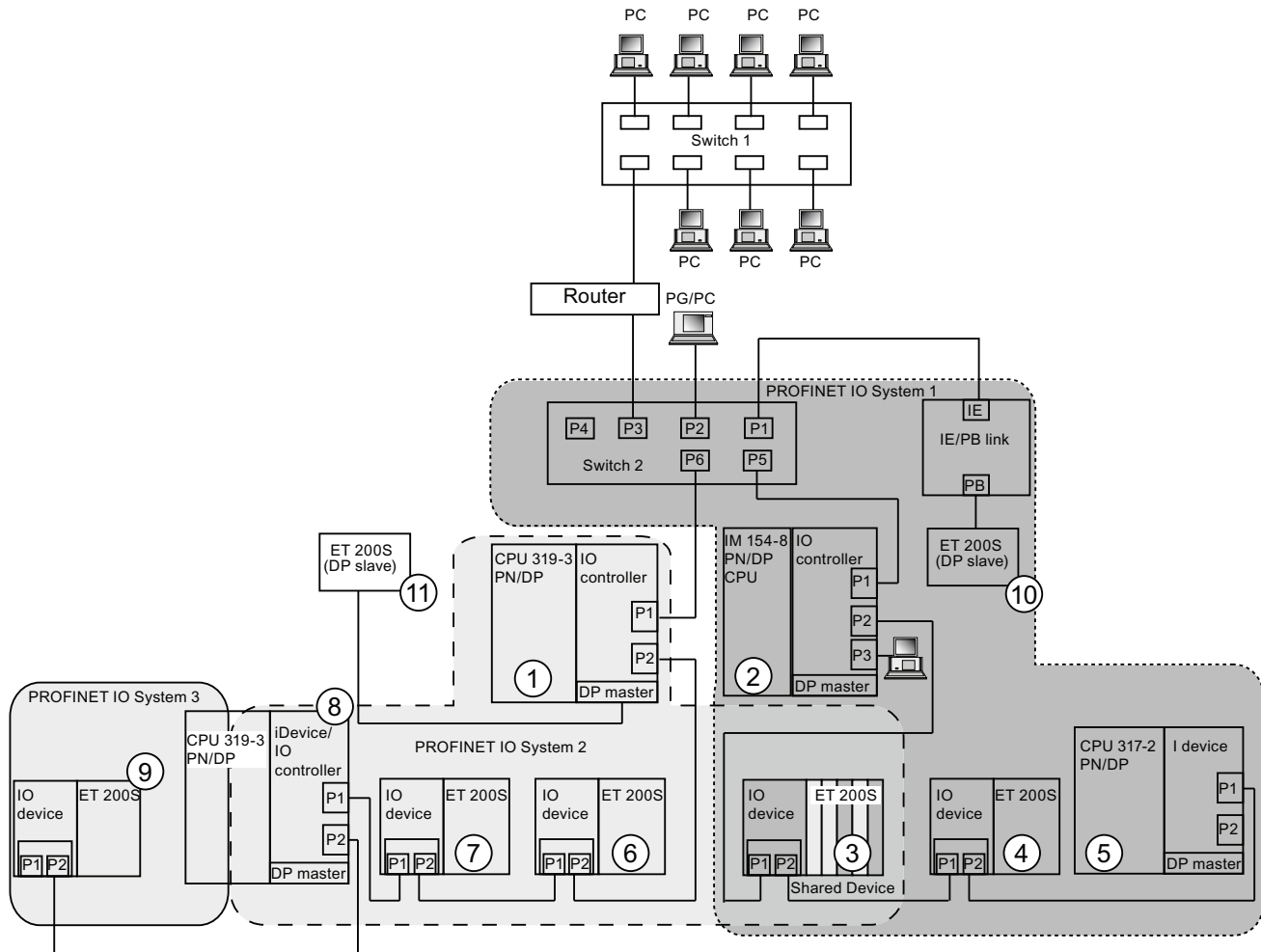

The graphic shows	Examples of connection paths
The connection of company network and field level	You can access devices at the field level from PCs in your company network Example: <ul style="list-style-type: none"> PC - Switch 1 - Router - Switch 2 - CPU 319-3 PN/DP ①.
Connections between the automation system and field level	You can also access other areas on the Industrial Ethernet from a programming device at the field level. Example: <ul style="list-style-type: none"> PG - integrated switch IM 154-8 CPU ② - Switch 2 - integrated switch CPU 319-3 PN/DP ① - integrated switch IO Device ET 200 S ⑤ - on IO Device ET 200S ⑥.

The graphic shows	Examples of connection paths
<p>The IO controller of the CPU IM 154-8 CPU ② sets up PROFINET IO system 1 and directly controls devices on the Industrial Ethernet and PROFIBUS.</p>	<p>At this point, you can see the IO feature between the IO controller, intelligent device, and the IO devices on the Industrial Ethernet:</p> <ul style="list-style-type: none"> • IM 154-8 CPU ② acts as IO controller for the IO devices ET 200S ③ and ET 200S ④, for switch 2, and for the intelligent device CPU 317-2 PN/DP ⑤. • IO device ET 200S ③ is operated as shared device, which means that IM154-8 CPU ② operating as controller can access only the (sub)modules it has been assigned as controller for that IO device. • The IM 154-8 CPU ② is also the IO controller for ET 200S (DP slave) ⑩ by way of IE/PB Link.
<p>The CPU 319-3 PN/DP ① operates as IO controller for PROFINET system 2 and, at the same time, as DP master on the PROFIBUS. In addition to other IO devices, this IO controller is used to operate a CPU319-3 PN/DP ⑧ as intelligent device which, in turn, operates a PROFINET subsystem as IO controller.</p>	<p>Here you can see that a CPU can be both the IO controller for an IO device and the DP master for a DP slave:</p> <ul style="list-style-type: none"> • CPU 319-3 PN/DP ① is the IO controller for the IO devices ET 200S ⑥ and ET 200S ⑦, and for the intelligent device CPU 319-3 PN/DP ⑧. • Moreover, CPU319-3 PN/DP ① shares the IO device ET 200S ③ with IO controller IM 154-8 CPU ②, which means that the CPU319-3 PN/DP ① operating as controller can access only the (sub)modules it has been assigned as controller for that IO device. • CPU319-3 ⑧, which is operated as intelligent device on CPU319-3 PN/DP ①, also acts as IO controller and sets up its own PROFINET system 3 on which the IO device ET 200S ⑨ is operated. • The CPU 319-3 PN/DP ① is the DP master for one DP slave ⑪. The DP slave ⑪ is assigned locally CPU 319-3 PN/DP ① and is not visible on the Industrial Ethernet.

Additional information

You will find additional information about PROFINET in the documents listed below:

- In the System Description PROFINET (<http://support.automation.siemens.com/WW/view/en/19292127>)
- In the *From PROFIBUS DP to PROFINET IO programming manual*. This manual also provides a clear overview of the new PROFINET blocks and system status lists.

4.11.4 Routed network transitions

Example: Programming device access beyond network limits (routing)

A CPU with several interfaces can also serve as a router for intercommunication with different subnets. With a PG you can access all modules on local and remote networks.

Requirements:

- Implement STEP 7 starting with Version 5.0.
Note: For STEP 7 requirements with respect to the CPUs used, refer to the technical specifications.
- Assign the PG/PC to a network in your STEP 7 project (SIMATIC Manager, assigning a PG/PC).
- The various networks are interconnected using modules with routing functions.
- After you configured all networks in NETPRO, initiated a new compilation for all stations, and then download the configuration to all modules with routing function. This also applies to all changes made in the network.

All routers therefore know all paths to a destination station.

Access to remote networks

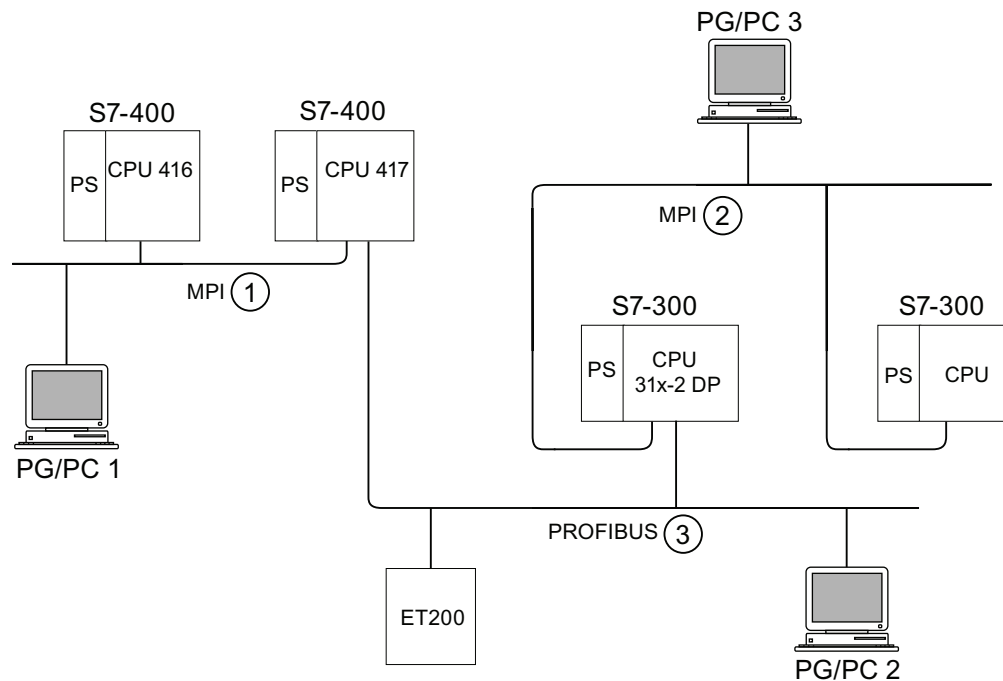

Figure 4-8 Access to remote networks

Example 1

To access the CPU 31x-2 DP using PG/PC 1:

PG/PC 1 - MPI network ① - CPU 417 as router - PROFIBUS network ③ - CPU 31x-2 DP

Example 2

To access the the S7-300 CPU (on the right in the figure) using PG/PC 2:

PG/PC 2 - PROFIBUS network ③ - CPU 31x-2 DP as router - MPI network ② - S7-300 CPU

Example 3

To access the 416 CPU using PG/PC 3:

PG/PC 3 - MPI network ② - CPU 31x-2 DP as router - PROFIBUS network ③ - CPU 417 as router - MPI network ① - CPU 416

Note

Only for CPUs with DP interface:

If these CPUs are operated as I-slaves and you want to use routing functionality, set the Commissioning / Debug Mode / Routing check box in the DP Interface for DP Slave dialog box in STEP 7.

Reference

You can find more information on the subject of routing in the "*Communication with SIMATIC*" manual.

4.11.5 Point-to-point (PtP)

Availability

CPUs with the "PtP" name suffix have at least one PtP interface.

Properties

Using the PtP interface of your CPU, you can connect external devices with serial interface. You can operate such a system at transmission rates up to 19.2 kbps in full duplex mode (RS 422), and up to 38.4 kbps in half duplex mode (RS 485).

Baud rate

- Half duplex: 38,4 kbps
- Full duplex: 19,2 kbps

Drivers

PtP communication drivers installed in those CPUs:

- ASCII drivers
- 3964(R) Protocol
- RK 512 (CPU 314C-2 PtP only)

Devices capable of PtP communication

Devices equipped with a serial port, for example, barcode readers, printers, etc.

Reference

CPU 31xC: Technological functions manual

4.11.6 Actuator/sensor interface (ASI)

Actuator/Sensor Interface (ASI)

Implementation using communication processors (CP).

The ASI, or Actuator/Sensor Interface, represents a subnet system on the lowest process level for automation systems. It is designed especially for networking digital sensors and actuators. The maximum data volume is 4 bit per slave station.

S7-300 CPUs require communication processor for the ASI connection.

Installing

5.1 Installing an S7-300

Here we will explain the steps required for the mechanical assembly of an S7-300.

Note

Note the installation guidelines and notes on safety in this manual when mounting, commissioning and operating S7-300 systems.

Open components

S7-300 modules are "Open Components" according to IEC 61131-2 and an "open type" according to UL/CSA Approval.

In order to conform with specifications on safe operation relating to mechanical strength, inflammability, stability and touch-protection, the following alternative installation modes are prescribed:

- Installation in a suitable cubicle
- Installation in a suitable cabinet
- Installation in an appropriately equipped and closed operating area

Access to these areas must only be possible with a key or tool. Only trained or authorized personnel are allowed access to these cubicles, cabinets or electrical operating rooms.

Accessories included

Installation accessories are included with the module package. The appendix contains a list of accessories and spare parts together with the corresponding order numbers.

Table 5- 1 Module accessories

Module	Accessories included	Explanation
CPU	1 x Slot number label	For assigning slot numbers
	Inscription labels	for the MPI address and Firmware Version (all CPUs) for labeling of integrated inputs and outputs (CPU 31xC only)
Signal module (SM) Function Module (FM)	1 Bus connector	For electrical interconnection of modules
	1 Labeling strip	For labeling module I/O
Communication module (CP)	1 Bus connector	For electrical interconnection of modules
	1 Inscription label (only CP 342-2)	For labeling the AS interface connector
Interface module (IM)	1 Bus connector	For electrical interconnection of modules
	1 x Slot number label (only IM 361 and IM 365)	For assigning slot numbers on racks 1 to 3

Tip: Templates for the labeling strips are available on the Internet (<http://support.automation.siemens.com/WW/view/en/11978022>).

Tools and materials required

To install the S7-300, you require the tools and materials listed in the table below.

Table 5- 2 Installation tools and materials

You require ...	for ...
cutting the 2 m rail to length	commonly available tool
scribing and drilling holes on the 2 meter rail	commonly available tool, 6.5 mm diameter drill bit
screw-mounting the rail	wrench or screwdriver, matching the selected fixing screws diverse M6 screws (length depends on the place of installation) with nuts and spring lock washers
screw-fastening the modules on the rail	screwdriver with 3.5 mm blade width (cylindrical design)
pulling out the grounding slide contact to achieve ungrounded state	screwdriver with 3.5 mm blade width (cylindrical design)

5.2 Installing the mounting rail

Mounting rail versions available

- Ready-to-use, four standard lengths (with 4 holes for fixing screws and 1 ground conductor bolt)
- One meter mounting rail
May be shortened to any special length. Supplied without holes for fixing screws and without ground conductor bolt.

Requirement

Prepare the 2 m mounting rail for installation.

Preparing the 2 m mounting rail for installation

1. Cut the 2 m mounting rail to the required length.
2. Mark out:
 - four bores for the fixing screws (for dimensions, refer to "Dimensions for fixing holes")
 - one hole for the protective conductor bolt.
3. If the length of your rail exceeds 830 mm, you must stabilize it by providing additional holes for fixing it with more screws.

Mark out these holes along the groove in the middle section of the rail (see the Figure below). The pitch should be approx. 500 mm.

4. Drill the marked holes with a diameter of $6.5^{+0.2}$ mm for M6 screws.
5. Mount an M6 bolt for fixing the ground conductor.

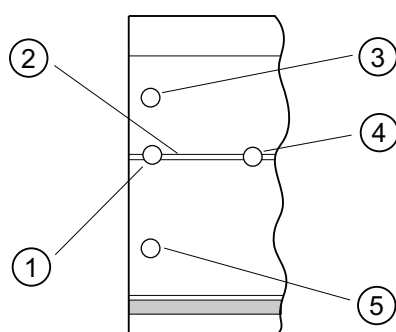

Number	Description
①	Hole for the ground conductor bolt
②	Groove for drilling additional holes for mounting screws
③	Hole for the mounting screw
④	Additional hole for mounting screw
⑤	Hole for the mounting screw

Dimension of the mounting holes

The mounting hole dimensions for the mounting rail are shown in the table below.

Table 5- 3 Mounting holes for rails

"Standard" mounting rail			2 m mounting rail	
Length of rail	Dimension a	Dimension b	-	
160 mm	10 mm	140 mm		
482.6 mm	8.3 mm	466 mm		
530 mm	15 mm	500 mm		
830 mm	15 mm	800 mm		

Fixing screws

You can use the following screw types for mounting the rails:

For ...	you can use ...	Explanation
outer fixing screws	Cylindrical head screw M6 to ISO 1207/ISO 1580 (DIN 84/DIN 85)	Choose a suitable screw length for your assembly. You also need size 6.4 washers to ISO 7092 (DIN 433)
	M6 hexagonal head screw to ISO 4017 (DIN 4017)	
Additional fixing screws (only 2 meter mounting rail)	Cylindrical head screw M6 to ISO 1207/ISO 1580 (DIN 84/DIN 85)	

Installing the mounting rail

1. Install the mounting rails so that sufficient space is available for installing modules and to allow heat dissipation (clearance of at least 40 mm above and below the modules. See the figure below).
2. Mark up the mounting holes on the mounting surface. Drill the holes with a diameter of $6.5^{+0.2}$ mm.
3. Screw the rail (M6 screws) onto the mounting surface.

Note

Always make sure of a low-impedance contact between the rail and a mounting surface, if the latter is a grounded metal panel or equipment mounting panel. On varnished or anodized metals, for instance, use a suitable contacting agent or contact washers.

The figure below shows the clearance required for the installation of an S7-300.

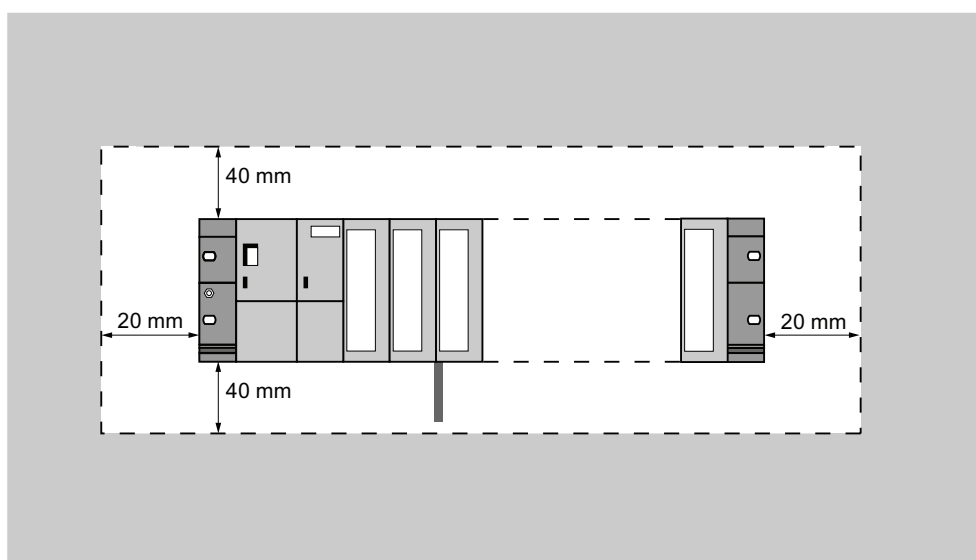

5.3 Installing modules on the mounting rail

Rules governing

The table below shows you points to follow when wiring, installing or removing S7-300 modules.

Rules for the tightening torque of..	... power supply, CPU,SM, FM, CP
Fixing modules to the mounting rail	from 0.8 Nm to 1.1 Nm

Requirements for module installation

- The configuration of the automation system is completed.
- The mounting rail is installed.

Mounting order of the modules

Hang the modules onto the rail, starting at the left and in the following order:

1. Power supply module
2. CPU
3. SMs, FMs, CPs, IMs

Note

Please check **before** you insert any SM 331 analog input modules whether you have to reposition the measuring range submodules at the side of the module. For more information, see the "Analog modules" chapter in the *Module Data Manual*.

Note

When installing an S7-300 system with ungrounded reference potential, make the relevant settings on the CPU. You ideally do so before you mount any modules onto the rail.

Installation steps

The various steps in module installation are explained below.

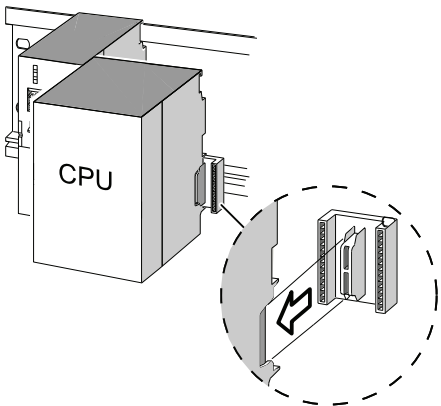
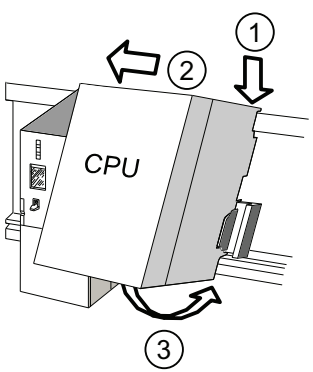
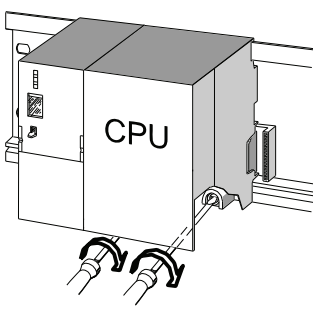
1.	<p>Plug the bus connectors into the CPU and signal/function/communication/interface modules.</p> <p>Each of these modules comes with a bus connector, except for the CPU.</p> <ul style="list-style-type: none"> • Always start at the CPU when you plug in the bus connectors. Remove the bus connector from the "last" module of the assembly. • Plug the bus connectors into the other modules. <p>The "last" module does not receive a bus connector.</p>	
2.	<p>Add all modules to the rail in the specified order ①, slide them up to the module on the left ②, then swing them down ③.</p>	
3.	<p>Screw-tighten the modules.</p>	

See also

Installing an S7-300 with ungrounded reference potential (not CPU 31xC) (Page 45)

5.4 Labeling modules

Assign slot numbers

You should assign a slot number to each one of the mounted modules, thus making it easier to assign the modules in the configuration table in STEP 7. The table below shows the slot number assignment.

Table 5- 4 Slot numbers for S7 modules

Slot numbes	Module	Remark
1	Power supply (PS) module	–
2	CPU	–
3	Interface module (IM)	to the right of the CPU
4	1. Signal module (SM)	to the right of the CPU or IM
5	2. Signal module	–
6	3. Signal module	–
7	4. Signal module	–
8	5. Signal module	–
9	6. Signal module	–
10	7. Signal module	–
11	8. Signal module	–

Attach the slot numbers to the modules.

1. Hold the corresponding slot number in front of the relevant module.
2. Place the tongue in the opening on the module ①.
3. Press the slot number into the module ②. The slot number breaks off from the wheel.

The figure below illustrates this procedure. The slot number labels are included with the CPU.

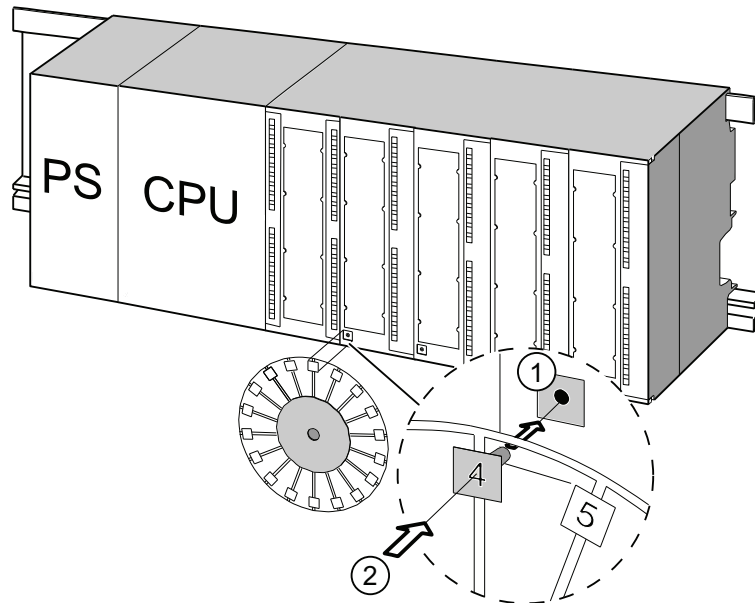

Wiring

6.1 Requirements for wiring the S7-300

This chapter

describes the requirements for wiring the power supply, CPU and front connectors.

Accessories required

The following accessories are required for wiring the S7-300.

Table 6- 1 Wiring accessories

Accessories	Explanation
Front connectors	for connecting the sensors / actuators of the system to the S7-300
Labeling strips	for labeling the module I/Os
Shield connection element, shielding terminals (matching the shielding diameter)	for connecting cable shielding

Tools and material required

Tools and materials required for wiring the S7-300.

Table 6- 2 Tools and material for wiring

To ...	you need ...
Connect the protective conductor to the rail	Wrench (size 10) Protective conductor cable (cross-section $\geq 10 \text{ mm}^2$) with M6 cable lug M6 nut, washer, spring lock washer
Adjust the power supply module to mains voltage	Screwdriver with a blade width of 4.5 mm
Wire the power supply module and the CPU	Screwdriver with a 3.5-mm blade, side-cutters, stripping tool Flexible cable, for example, sheathed flexible cable $3 \times 1.5 \text{ mm}^2$ Wire end ferrules to DIN 46228
Wire the front connector	Screwdriver with a 3.5-mm blade, side-cutters, stripping tool Flexible cables, 0.25 mm^2 to $0.75/1.5 \text{ mm}^2$ Shielded cables as required Wire end ferrules to DIN 46228

Wiring conditions for power supply and CPU

Table 6-3 Wiring conditions for power supply and CPU

Connectable cables	to power supply and CPU
Solid conductors	No
Flexible conductors <ul style="list-style-type: none"> without wire end ferrule With wire end ferrule 	0.25 mm ² to 2.5 mm ² 0.25 mm ² to 1.5 mm ²
Number of conductors per terminal	1 or 2, up to 1.5 mm ² (total) in a common wire end ferrule
Diameter of the conductor insulation	max. 3.8 mm
Stripped length	11 mm
Wire end ferrules to DIN 46228 <ul style="list-style-type: none"> without insulating collar with insulating collar 	Design A, 10 mm to 12 mm length Design E, up to 12 mm length
Tightening torque	from 0.5 Nm to 0.8 Nm

Wiring conditions for front connectors

Table 6-4 Wiring conditions for front connectors

Connectable cables	Front connectors	
	20-pole	40-pole
Solid conductors	No	No
Flexible conductors <ul style="list-style-type: none"> without wire end ferrule with wire end ferrule 	0.25 mm ² to 1.5 mm ² 0.25 mm ² to 1.5 mm ²	0.25 mm ² to 0.75 mm ² 0.25 mm ² to 0.75 mm ² <ul style="list-style-type: none"> Mains feed 1.5 mm²
Number of conductors per terminal	1 or 2, up to 1.5 mm ² (total) in a common wire end ferrule	1 or 2, up to 0.75 mm ² (total) in a common wire end ferrule
Diameter of the conductor insulation	max. 3.1 mm	<ul style="list-style-type: none"> max. 2.0 mm for 40-pole cables max. 3.1 mm for 20-pole cables
Stripped length	6 mm	6 mm
Wire end ferrules to DIN 46228 <ul style="list-style-type: none"> without insulating collar with insulating collar 	Design A, 5 mm to 7 mm length Design E, up to 6 mm length	Design A, 5 mm to 7 mm length Design E, up to 6 mm length
Tightening torque	from 0.4 Nm to 0.8 Nm	

6.2 Bonding the Protective Conductor to the Mounting Rail

Requirement

The mounting rail is fixed onto the mounting surface.

Connecting the protective conductor

Connect the mounting rail to the protective conductor.

The mounting rail is provided with a M6 protective conductor screw for this purpose.

Minimum cross-section of the protective conductor: 10 mm²

The figure below shows how the protective conductor has to be bonded to the rail.

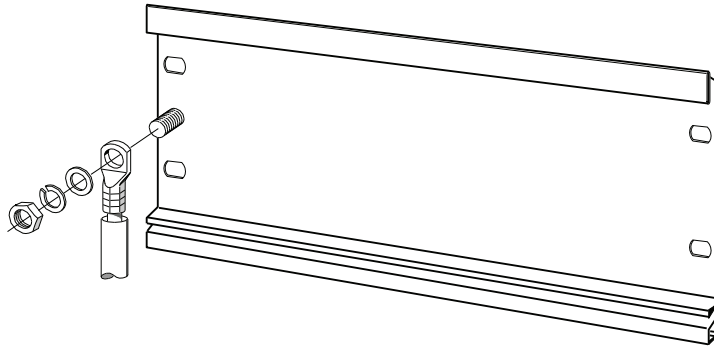

Note

Always make sure of a low-impedance contact between the protective conductor and the rail. You can achieve this by using a low-impedance cable, keeping it as short as possible and contacting it to a large surface.

For example, an S7-300 mounted on a hinged frame must be connected to ground using a flexible grounding strap.

6.3 Adjusting the power supply module to local mains voltage

Introduction

You can operate the S7-300 power supply module on 120 VAC or 230 VAC. On older power supply modules PS307 with **selectable** input voltage range, the mains voltage is always set at the factory to the default 230 V.

Note

On the new S7-300 power supplies PS307, the input voltage range is selected **automatically**.

The MLFBs of the new power supply modules:

- PS307 2 A, 6ES7307-1BA01-0AA0
 - PS307 5 A, 6ES7307-1EA01-0AA0
 - PS307 10 A, 6ES7307-1KA02-0AA0
-

Setting the mains voltage selector switch

Verify that the setting of the voltage selector switch matches your local mains voltage.

To set the selector switch:

1. Remove the protective cap with a screwdriver.
2. Set the selector switch to match the local line voltage.
3. Reinsert the protective cap.

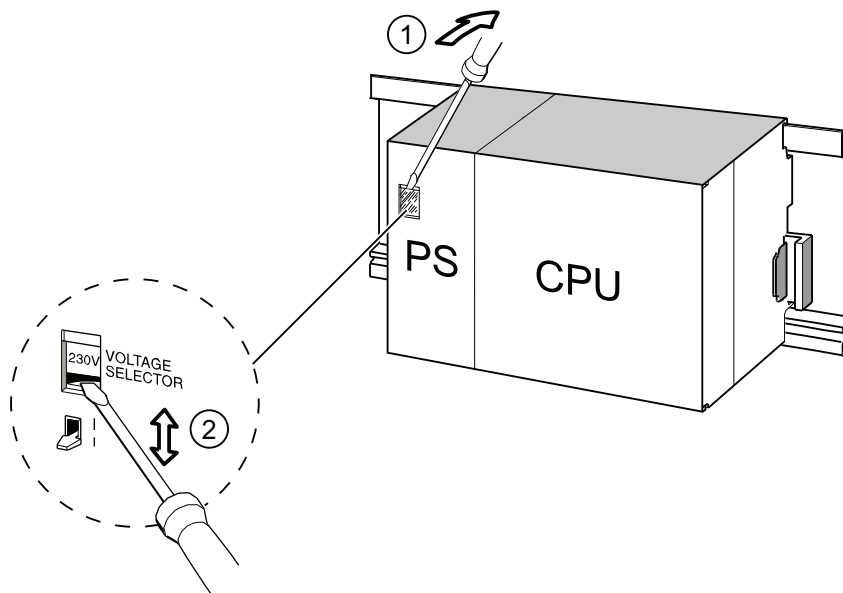

Numeral	Designation
①	Remove the protective cap with a screwdriver
②	Set selector switch to mains voltage

6.4 Wiring the power supply module and the CPU

Requirement

All modules are mounted onto the rail.

Wiring the PS and CPU

Note

The PS 307 power supply module is equipped with two additional 24 VDC terminals L+ and M for the supply of I/O modules.

Note

The power supply connector of your CPU is a plug-in device and can be removed.

WARNING

There is a risk of contact to live wires if the power supply module, or any additional load power supply units, are connected to the mains.

You should therefore isolate the S7-300 from power before you start wiring it. Always use crimp ferrules with insulating collars for the conductors. Close all front panels of the modules when you have completed the wiring. This is conditional before you reconnect the S7-300 to power.

1. Open the PS 307 power supply module and CPU front panels.
2. Open the strain relief on the PS 307.
3. Strip the power cable to a length of 11 mm and connect it to L1, N and to the protective earth (PE) terminal of the PS 307.
4. Screw-tighten the strain relief again.
5. Next, wire the PS and CPU

The power supply connector of the CPUs is a removable plug-in device.

Strip the connecting cables for the CPU power supply to a length of 11 mm. Wire the lower terminal M on the PS 307 to the terminal M of the CPU and the lower terminal L+ on the PS 307 to terminal L+ of the CPU.

WARNING

Reversing the polarity of the M and L+ terminals trips the internal fuse on your CPU. Always interconnect the M and L+ terminals of the power supply module and of the CPU.

6. Close the front panels.

The figure below illustrates the procedures described earlier.

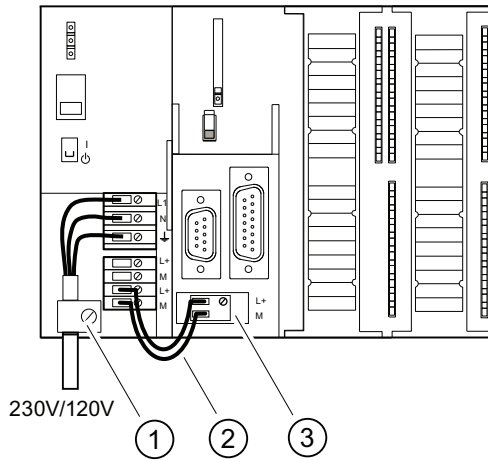

Numeral	Designation
①	Strain relief of the power supply cable
②	Connection cables between the PS and CPU
③	Removable power supply connector

Note

The PS 307 power supply module is equipped with two additional 24 VDC terminals L+ and M for the supply of I/O modules.

6.5 Wiring front connectors

Introduction

The sensors and actuators of your system are connected to the S7-300 AS by means of front connectors. Wire the sensors and actuators to the front connector and then plug it into the module

Front connector versions

Front connectors come in 20-pin and 40-pin versions with screw contacts or spring terminals. You require 40-pin front connectors for the CPUs 31xC and 32-channel SMs.

Use the following front connectors as required for the module:

Table 6- 5 Assignment of front connectors to modules

Module	Front connector with screw terminals, order no.:	Front connector with spring terminals, order no.:
Signal modules (not 32-channel), Function modules, Communication module CP 342-2	6ES7392-1AJ00-0AA0	6ES7392-1BJ00-0AA0
Signal modules (32-channel) and CPU 31xC	6ES7392-1AM00-0AA0	6ES7392-1BM01-0AA0

Connecting on spring terminals

It is quite easy to wire a front connector with spring terminals: Simply insert the screwdriver vertically into the opening with the red opening mechanism, insert the wire into the terminal and remove the screwdriver.

WARNING

You might damage the spring clamp mechanism of the front connector if you turn the screwdriver sideways or use the wrong size of screwdriver. Always slide a matching screwdriver vertically into the desired opening until it reaches the mechanical stop. This ensures that the spring terminal is fully open.

Tip

There is a separate opening for test probes up to 2 mm in diameter to the left of the opening for the screwdriver.

Requirement

The modules (SM, FM, CP 342-2) are mounted on the rail.

Preparing the front connectors and cables

<p>⚠ WARNING</p> <p>There is a risk of contact to live wires if the power supply module, or any additional load power supply units, are connected to the mains.</p> <p>You should therefore isolate the S7-300 from power before you start wiring it. Close all front panels of the modules when you have completed the wiring. This is conditional before you reconnect the S7-300 to power.</p>
--

1. Switch off the power supply.
2. Open the front door.
3. Place the front connector into wiring position.
Push the front connector into the signal module until it latches. In this position, the front connector still protrudes from the module.
Advantage of this wiring position: Convenient wiring.
The front connector has no contact with the module in this wiring position.
4. Strip the conductors to a length of 6 mm.
5. Crimp the wire end ferrules, for example, to terminate two conductors at one terminal.

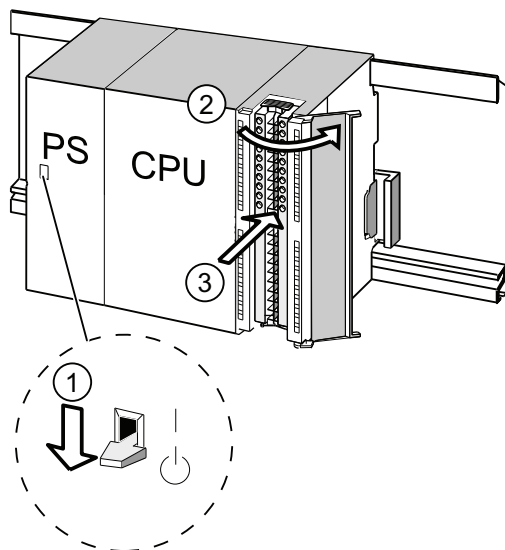

Numeral	Designation
①	Power supply (PS) turned off
②	Open module
③	Front connector in wiring position

Wiring front connectors

Table 6- 6 Wiring front connectors

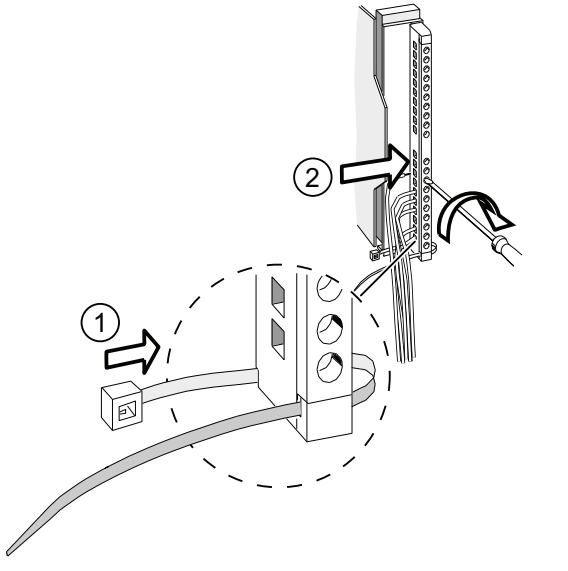
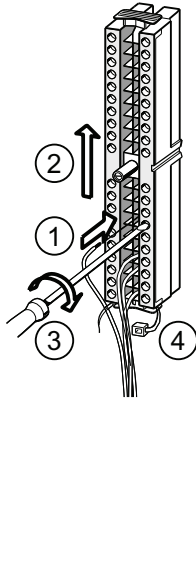
Step	20-pin front connector	40-pin front connector
1.	Place the included cable strain relief into the front connector.	–
2.	Cable exit at the bottom of the module?	
	<p>If yes: Starting at terminal 20, work your way down to terminal 1.</p> <p>If not: Start wiring at terminal 1, and work your way up to terminal 20.</p>	<p>Start wiring at terminal 40 or 20, and work in alternating passes from terminals 39, 19, 38, 18 etc. until you have reached terminals 21 and 1.</p> <p>Start wiring at terminal 1 or 21, and work in alternating passes from terminals 2, 22, 3, 23 etc. until you have reached terminals 20 and 40.</p>
3.	Front connectors with screw terminals: Always screw-tighten the unused terminals.	
4.	–	Place the strain relief around the cable harness and the front connector.
5.	Tighten the strain relief for the cable harness. Push in the strain relief to the left to increase cable space.	
		
	The work step numbers are shown in the figure above	
	① Insert the strain relief. ② Wire the terminals.	① to ③ Wire the terminals. ④ Tighten the strain relief clamp.

Reference

For information on wiring the integrated I/O of 31xC CPUs, refer to the *CPU 31xC and CPU 31x, Technical Data* manual.

6.6 Plugging the front connectors into modules

Requirement

The front connectors are completely wired.

Inserting the front connector

Table 6-7 Inserting the front connector

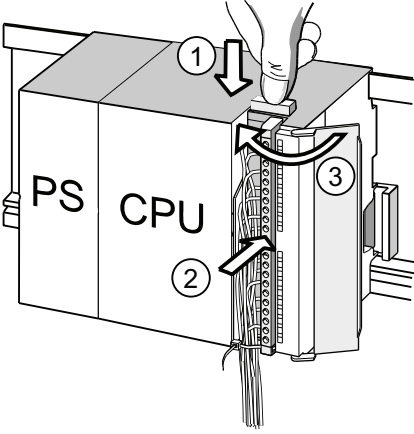
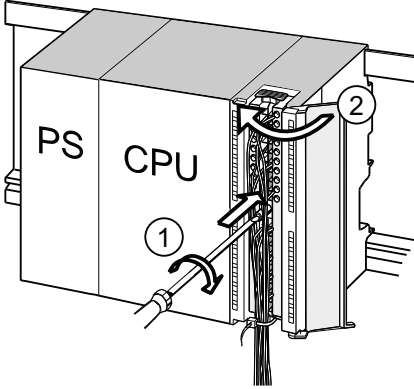
Step	20pin front connector	40pin front connector
1.	<p>Push in the unlocking mechanism on top of the module.</p> <p>Keeping the locking mechanism pressed, insert the front connector into the module.</p> <p>Provided the front connector is seated correctly in the module, the unlocking mechanism automatically returns to the initial position when you release it.</p>	<p>Tighten the mounting screw in the center of the connector.</p> <p>This pulls the front connector completely into contact with the module.</p>
<p>Note</p> <p>When you insert the front connector into the module, an encoding mechanism engages in the front connector, thus ensuring that the connector can only be inserted into modules of the same type.</p>		
2.	<p>Close the front panel.</p> 	<p>Close the front panel.</p> 
<p>The work step numbers are shown in the figure above</p>		
<p>① Keep the release mechanism pressed</p> <p>② Insert the front connector</p> <p>③ Only then close the front panel.</p>		<p>① Tighten the mounting screw,</p> <p>② Only then close the front panel.</p>

6.7 Wiring I/O modules and compact CPUs with Fast Connect

Order numbers for Fast Connect Connectors

- 20-pin connector: 6ES7392-1CJ00-0AA0
- 40-pin connector: 6ES7392-1CM00-0AA0



Wiring I/O modules and compact CPUs with Fast Connect

- I/O modules and compact CPUs can be wired with Fast Connect. The individual wires are connected by means of the front connector using Fast Connect technology, which requires no stripping.
- Fast Connect is a connection method that requires no conductor preparation (i.e., the conductor insulation does not have to be stripped).
- Each terminal with Fast Connect has a test opening (e.g. for measuring the voltage). The test opening is suitable for test probes with a maximum diameter of 1.5 mm.
- Wire end ferrules are not permitted.

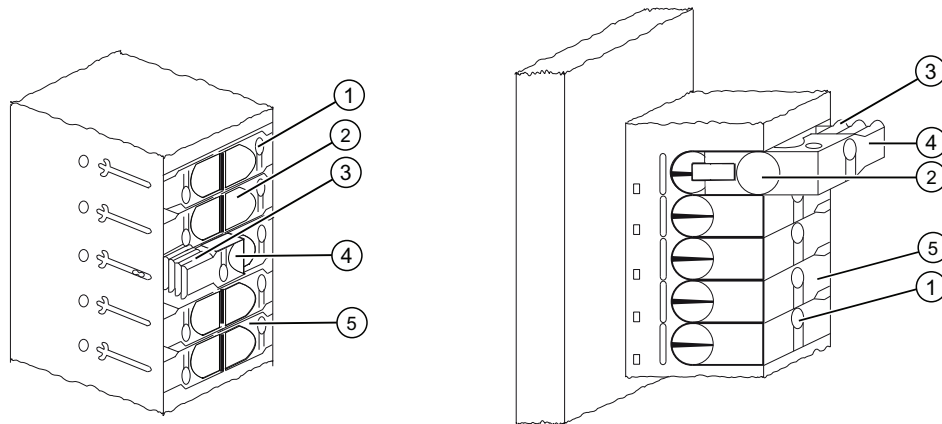

Numeral Designation

- ① Opening for testing: max. Ø 1.5 mm
- ② Opening for a conductor: 0.25 mm² to 1.5 mm²
- ③ Tooth for opening the terminal
- ④ Guide clip opened (the wire can be inserted)
- ⑤ Guide clip closed (the wire is connected)

Figure 6-1 Schematic representation of Fast Connect connectors

Wiring rules for front connector with Fast Connect

	20-pin front connector	40-pin front connector
Solid wires	No	No
Connectable wire cross-section of flexible wires		
• Without wire end ferrule	0.25 mm ² to 1.5 mm ²	0.25 mm ² to 1.5 mm ²
• With wire end ferrule	-	-
Number of wires per terminal	1	1
Number of terminating cycles for the same conductor cross-section	25 ¹	25 ¹
Maximum external diameter of the wire insulation	∅ 3.0 mm	∅ 3.0 mm
¹ For 1.5 mm ² only 10 terminating cycles are possible. If different conductor cross-sections are used in a connecting terminal as a result of rewiring, it can be wired a maximum of 10 times.		

Required tools

Screwdriver, 3.0 mm or 3.5 mm.

Connectable cables

- Flexible conductors with PVC insulation and a conductor cross-section of: 0.25 mm² to 1.5 mm²

A list of the tested conductors can be found at: <http://www.weidmueller.de>

UL-compliant cables and connections

Wiring range for insulating piercing connection 22 -16 AWG solid/stranded PVC insulated conductors, UL style no. 1015 only.

Procedure for wiring with Fast Connect

1. Insert the unstripped wire into the round opening until it stops (**the insulation and conductor must form a flat surface**) and secure the conductor in this position.
 - For 20-pin connector: at a 90° angle
 - For 40-pin connector: at a 45° angle
2. Insert the screwdriver into the indentation on the topside of the guide clip.
3. Press the screw driver downwards until the guide clip is engaged in the end position. The wire is connected.

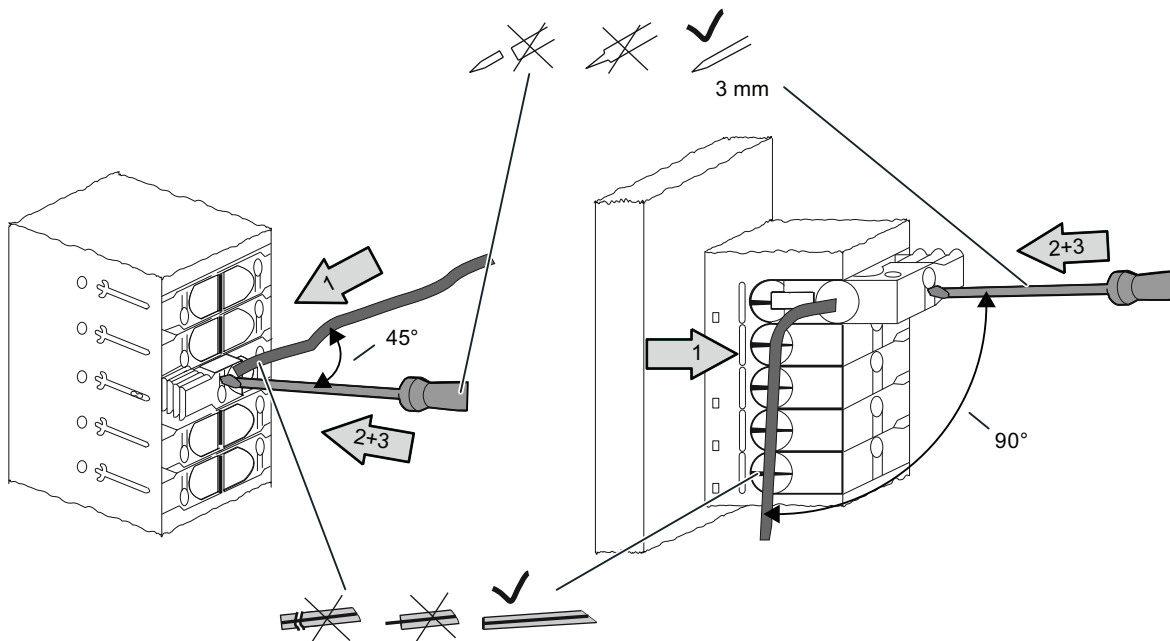

Note

If you would like to reuse a conductor after it was already connected once then it must be trimmed beforehand.

Procedure for disconnecting the wiring with Fast Connect

1. Insert the screwdriver into the opening next to the guide clip until it stops.
2. Using the screwdriver, apply upward leverage to the guide clip by means of the appropriate tothing. Repeat this action until the guide clip is engaged in the top position.
3. The wiring is disconnected. Remove the wire.

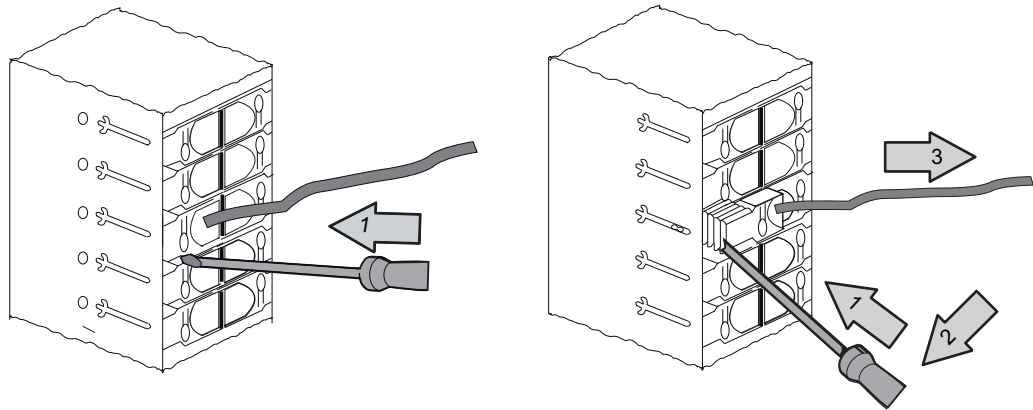

Figure 6-2 Disconnecting the wiring of a 40-pin Fast Connect connector

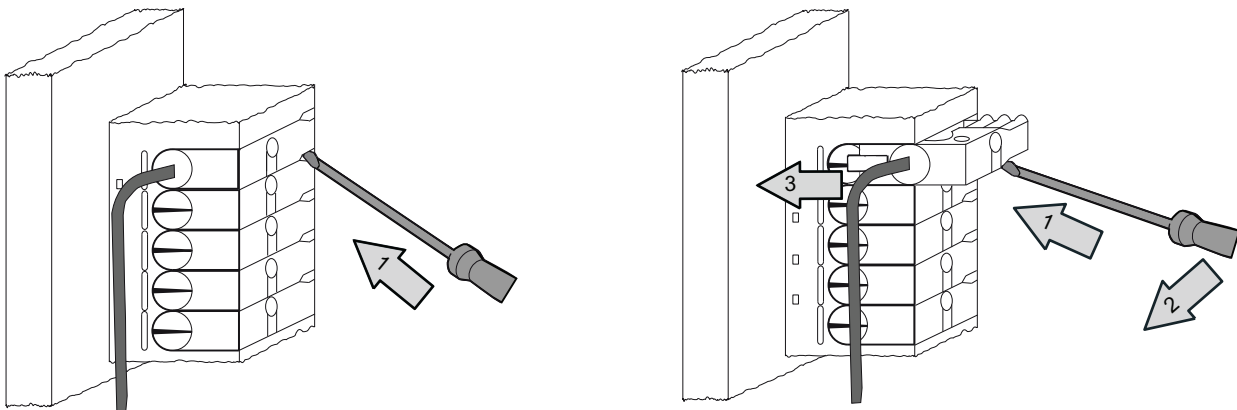

Figure 6-3 Disconnecting the wiring of a 20-pin Fast Connect connector

6.8 Labeling the module I/Os

Introduction

The labeling strips are used to document the assignment of module I/Os to the sensors / actuators of your system.

You have to use the following labeling strips, depending on the module:

Table 6- 8 Assignment of labeling strips to modules

Module	Labeling strip order no.:
SMs (not 32-channel), Function modules, Communication module CP 342-2	6ES7392-2XX00-0AA0
SMs (32-channel)	6ES7392-2XX10-0AA0

Filling out and inserting labeling strips

1. Label the strips with the addresses of the sensors / actuators.
2. Slide the labeled strips into the front panel.

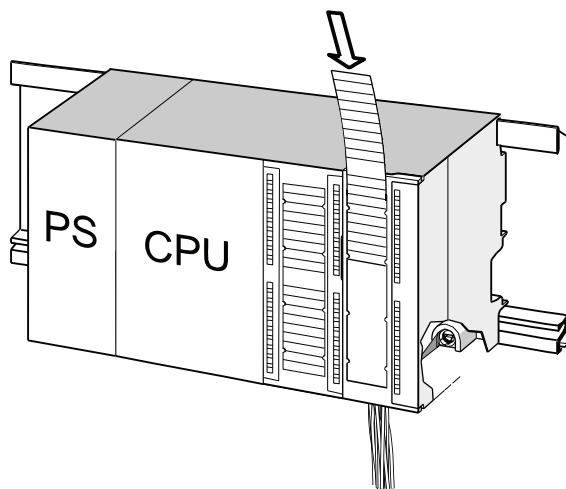

Tip

Templates for the labeling strips are available on the Internet under Internet (<http://support.automation.siemens.com/WW/view/en/11978022>).

6.9 Terminating shielded cables on the shield connection element

Application

The shield connection element allows easy grounding of all shielded cables of S7 modules, due to its direct contact to the mounting rail.

Design of the shield connection element

The shield connection element consists of

- a bracket with two screw bolts for rail mounting (order no.: 6ES7390-5AA00-0AA0) as well as
- the shielding terminals.

You must use the following shielding terminals, based on the shielding diameter of your cables:

Table 6- 9 Shielding diameter assignment to shielding terminals

Cable with shielding diameter	Shielding terminal order no.:
2 cables, each with shielding diameter of 2 mm to 6 mm	6ES7390-5AB00-0AA0
1 cable, shielding diameter 3 mm to 8 mm	6ES7390-5BA00-0AA0
1 cable, shielding diameter 4 mm to 13 mm	6ES7390-5CA00-0AA0

The shield connection element is 80 mm wide and provides space for 4 shielding terminals each in two rows.

Installing the shield connection element underneath two signal modules

1. Push the two screw bolts of the bracket into the guide on the underside of the mounting rail.
2. Place the bracket underneath the modules whose shielded cables are to be terminated.
3. Screw-tighten the bracket onto the rail.
4. The shielding terminal is equipped with a slotted web underneath. Place the shielding terminal at this position onto the edge of the bracket (see figure below). Push the shielding terminal down and pivot it into the desired position.

You can install a maximum of 4 shielding terminals on each of the two rows of the shield connection element.

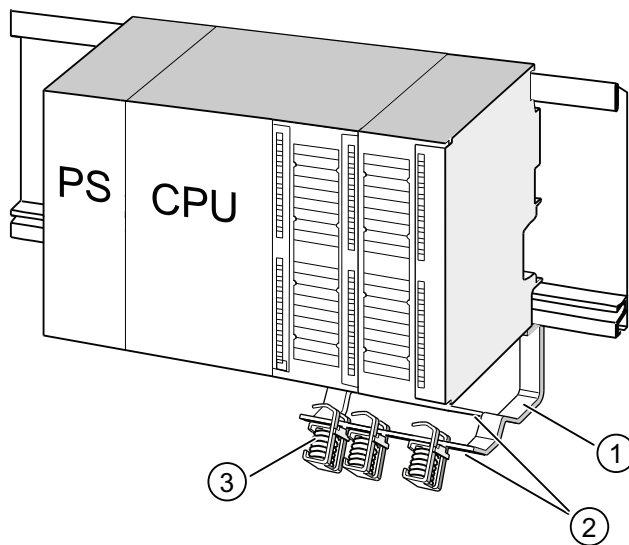

Numb Designation
er

- ① Bracket of shield connection element
- ② Edge of the bracket where the shielding terminal(s) has/have to be placed
- ③ Shielding terminals

Terminating 2-wire cables on shield connection elements

Only one or two shielded cables may be terminated per shielding terminal (see the figure below). The cable is clamped down at the stripped cable shielding.

1. Strip the cable shielding to a length of at least 20 mm.
2. Clamp in the stripped cable shielding underneath the shielding terminal.

Push the shielding terminal towards the module ① and feed the cable through the clamp opening ②.

If you need more than four shielding terminals, start wiring at the rear row of the shield connection element.

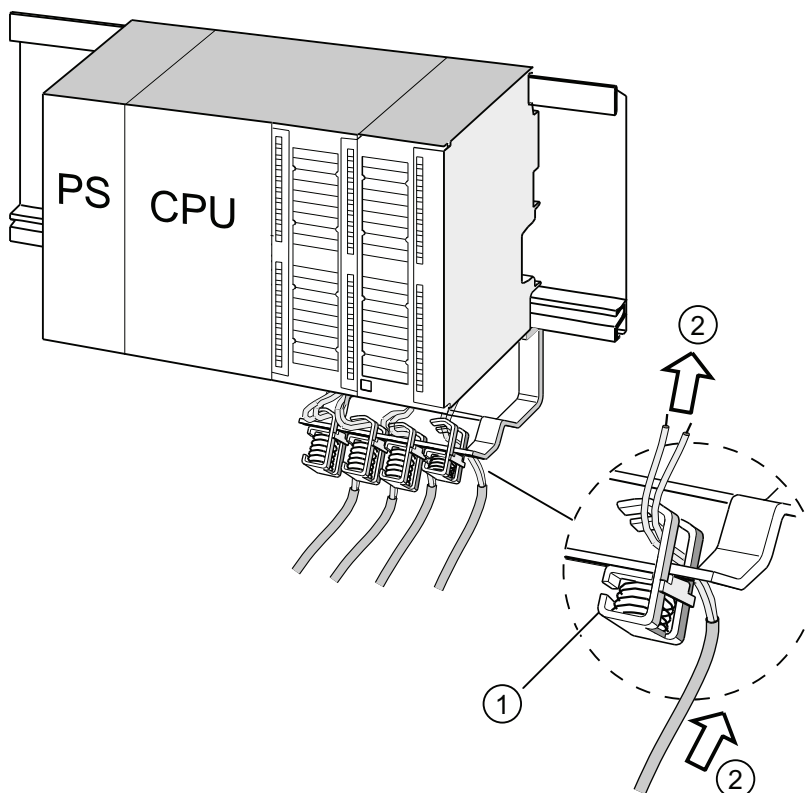

Number	Designation
①	Magnified view of the shielding terminal
②	Wiring of the shielding terminal

Tip

Provide a sufficient cable length between the shielding terminal and the front connector. This allows you to disconnect the front connector for repairs, without having to disconnect the shielding terminal also, for example.

See also

Cable shielding (Page 272)

6.10 Wiring bus connectors

You need to network all the nodes you integrate into a subnet of your system. The section below provides information about the wiring of the bus connectors.

6.10.1 MPI/PROFIBUS bus connector

Wiring a bus connector with screw terminals

1. Strip the bus cable.
For information about stripped lengths, refer to the product information included with the bus connector.
2. Open the bus connector housing.
3. Insert the green and the red wire into the screw-terminal block.
Always ensure that you connect the same wires to the same terminal (for example., green wire to terminal A, red wire to terminal B).
4. Press the cable sheath into the clamp. Make sure that the cable shield directly contacts the shielding contact surfaces.
5. Screw-tighten the wire terminals.
6. Close the bus connector housing.

Wiring a Fast Connect bus connector

1. Strip the bus cable.
For information about stripped lengths, refer to the product information included with the bus connector.
2. Open the strain relief of the bus connector.
3. Insert the green and red wire into the open contacting covers.
Always ensure that you connect the same wires to the same terminal (for example., green wire to terminal A, red wire to terminal B).
4. Close the contacting cover.
This presses the conductors into the insulation displacement terminals.
5. Screw-tighten the strain relief clamp. Make sure that the cable shield directly contacts the shielding contact surfaces.

Note

Use a bus connector with 90° cable outlet.

See also

Network components of MPI/DP and cable lengths (Page 63)

6.10.2 Setting up the terminating resistor on the PROFIBUS connector**Inserting a bus connector in a module**

1. Connect the wired bus connector to the module.
2. Screw the bus connector tightly onto the module.
3. If the bus connector is installed on the beginning or end of a segment, enable the terminating resistor (switch position "ON"; see the picture below).

Note

The bus connector 6ES7972-0BA30-0XA0 does not come with a terminating resistor. You cannot insert this type of bus connector at the beginning or end of a segment.

Please make sure during startup and normal operation that power is always supplied to nodes where the terminating resistor is active.

The figure below shows the switch settings of a bus connector:

Terminating resistor activated

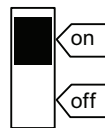

Terminating resistor not activated

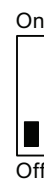
**Removing the fiber-optic cable**

You can unplug a bus connector with a looped-through bus cable at any time from the PROFIBUS DP interface without interrupting data exchange on the bus.

Possible data traffic errors

 **WARNING**

Data traffic error might occur on the bus!
A bus segment must always be terminated at both ends with the terminating resistor. For example, this is not the case when the last slave with the bus connector is deactivated. Because the bus connector takes its voltage from the station, this terminating resistor is ineffective. Please make sure that power is always supplied to stations on which the terminating resistor is active.

6.10.3 PROFINET bus connector

Wiring a Fast Connect bus connector

Devices are usually connected to the PROFINET interface by means of RJ45 connector.

For an overview of the product range and applications of the RJ45 connector, refer to chapter "PROFINET cable length and network dimensions (Page 85)"

When wiring the RJ45 connector by yourself, refer to the comprehensive installation instructions included. These instructions are also available on the Internet (<http://support.automation.siemens.com/WW/view/en/20691879>).

Special features for unlocking

In confined installation conditions, use a screwdriver with a 2.5 mm blade to unlock the connector.

Addressing

7.1 Slot-specific addressing of modules

Preface

For slot-specific addressing (default addressing mode if you have not yet downloaded any configuration data to the CPU), every slot number is assigned a module start address. This is a digital or analog address, based on the type of module.

This section shows you which module start address is assigned to which slot number. You need this information to determine the start addresses of the installed modules.

Maximum assembly and the corresponding module start addresses

The picture below shows the layout of an S7-300 on 4 racks, including the available slots and their module start addresses.

The input and output addresses for I/O modules begin at the same module start address.

Note

On a CPU 31xC system you cannot insert any modules into slot 11 of rack 3. The address range is reserved for the integrated I/O.

7.1 Slot-specific addressing of modules

The figure below shows the slots of an S7-300 and the corresponding module start addresses:

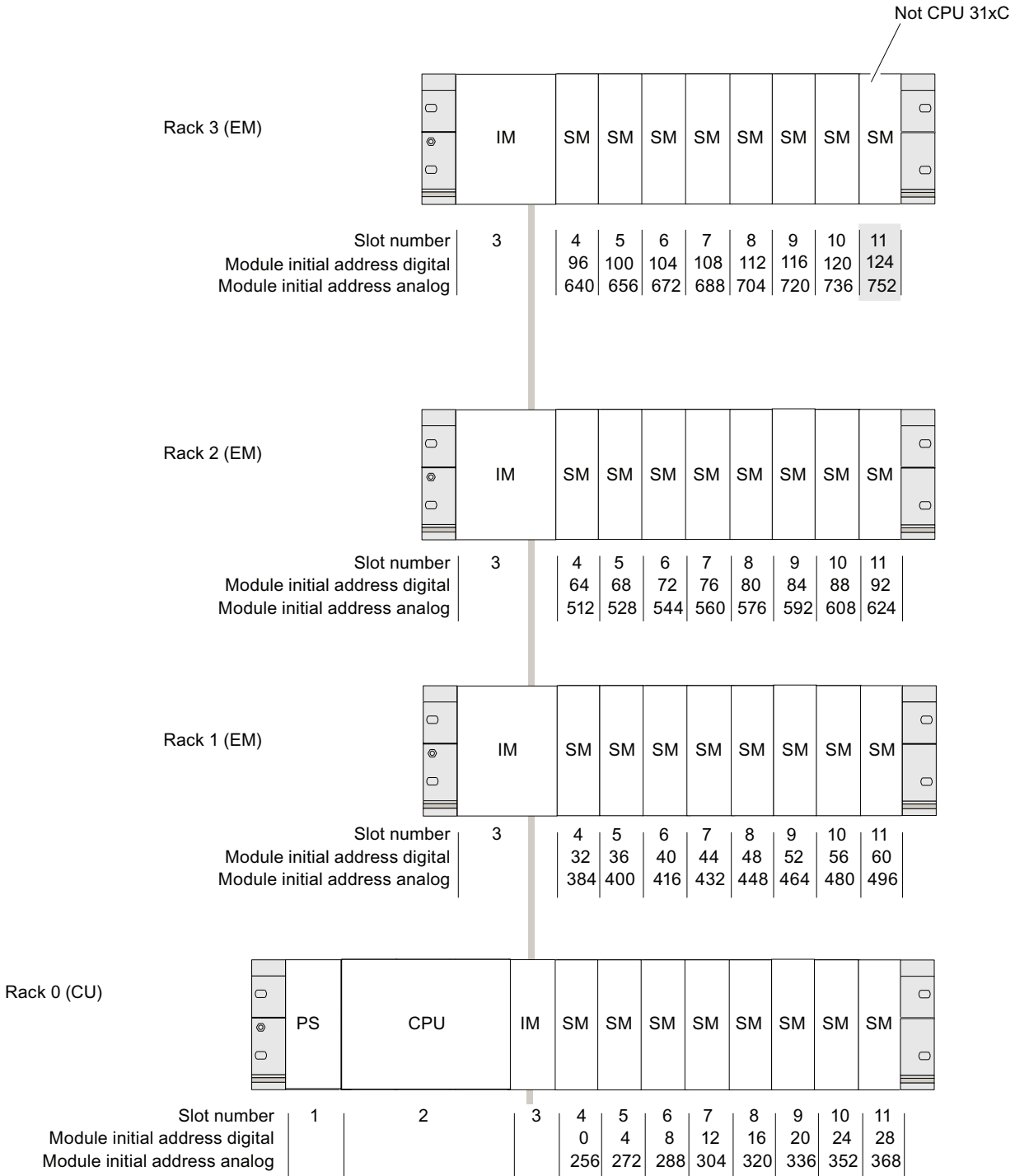

7.2 User-specific addressing of modules

7.2.1 User-specific addressing of modules

User-specific addressing

User-specific addressing means that you can assign an address of your choice to any module (SM/FM/CP). The addresses are assigned in STEP 7. There you specify the module start address that forms the basis for all other addresses of the module.

Advantages in user-specific addressing:

- Optimization of available address space as there are no "address gaps" between the modules.
- In your standard software configuration, you can define addresses which are independent of the relevant S7-300 configuration.

Note

You always configure the hardware in HW Config of STEP 7 when using PROFIBUS DP or PROFINET IO field devices. User-specific addressing is automatically set in this case. There is no fixed slot addressing for such a configuration.

7.2.2 Addressing digital modules

This section describes how to assign addresses to digital modules. You need this information in order to be able to address the channels of the digital module in the user program.

Addresses of digital modules

The address of an input or output of a digital module consists of a byte address plus a bit address.

Example: I 1.2

The example consists of:

- input I,
- byte address 1 and
- bit address 2

The byte address is based on the module start address.

The bit address is the number printed on the module.

When the first digital module is located in slot 4, its default start address is 0. The start address of each further digital module increments by the count of 4.

The figure below shows you how the scheme by which the addresses of the various channels of a digital module are derived.

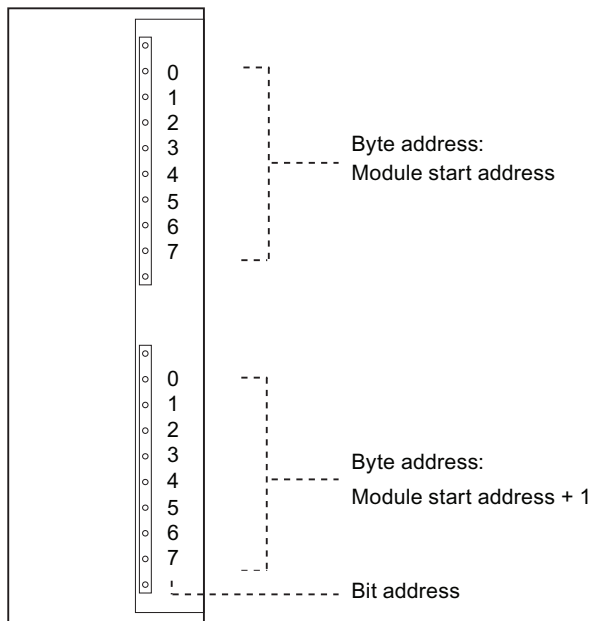

An example of digital modules

The example in the figure below shows which default addresses are derived when a digital module is located in slot 4 (that is, when the module start address is 0). Slot number 3 is not assigned, because the example does not contain an interface module.

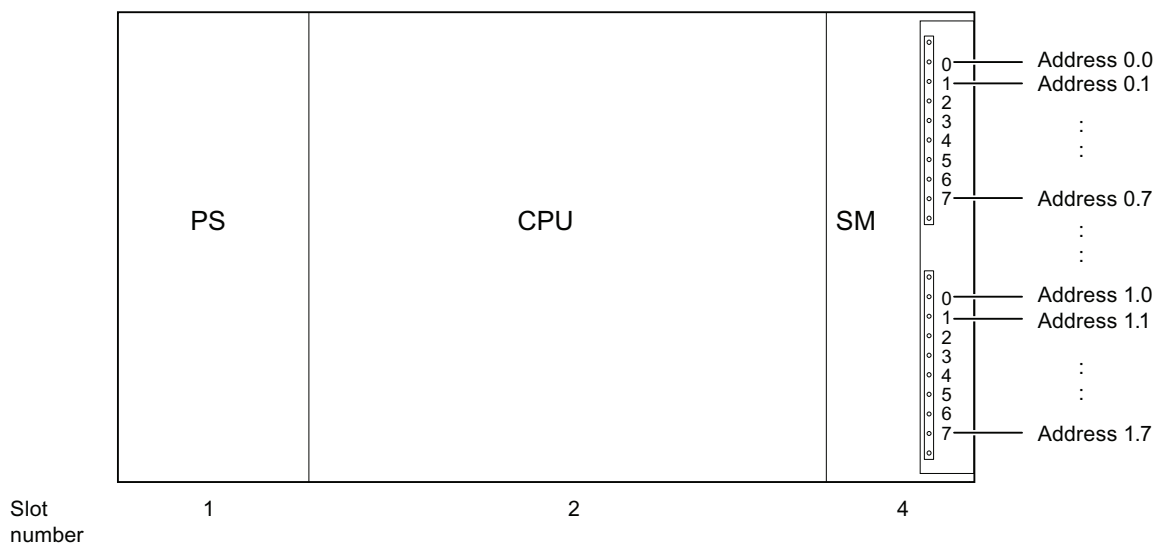

7.2.3 Addressing analog modules

This section describes how to address analog modules. You need this information in order to be able to address the channels of the analog modules in your user program.

Addresses of analog modules

The analog input or output channel is always assigned a word address. The channel address is based on the module start address. When the first analog is located in slot 4, its default start address is 256. The start address of each further analog module increments by the count of 16.

An analog I/O module has the same start addresses for its input and output channels.

An example of analog modules

The example in the figure below shows you which default channel addresses are derived for an analog module located at slot 4. You can see that all analog I/O channels of an analog I/O module are assigned the same start address, which is the module start address.

Slot number 3 is not assigned, because the example does not contain an interface module.

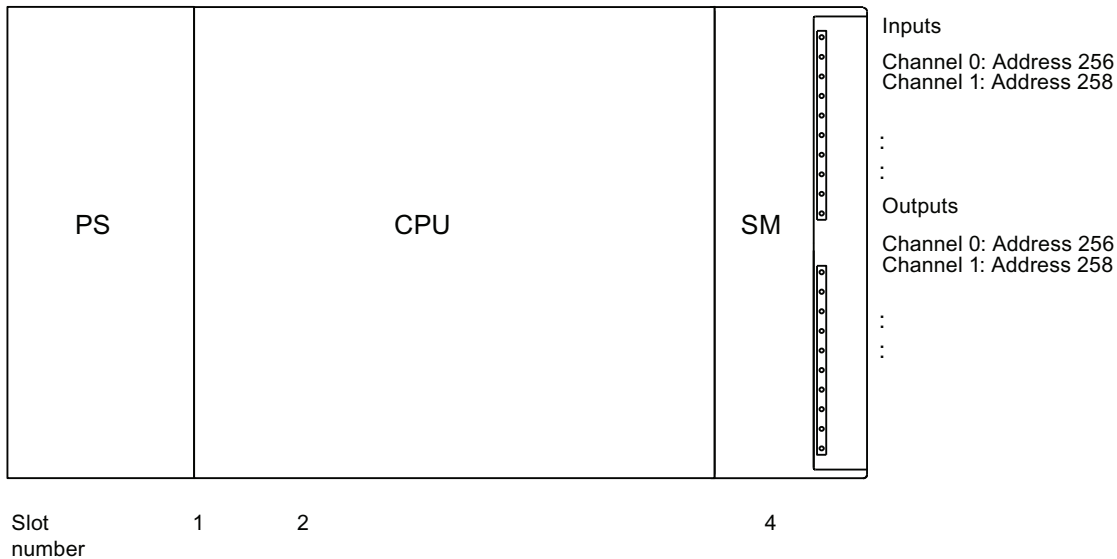

Figure 7-1 I/O addresses of an analog module at slot 4

7.2.4 Addressing the integrated I/Os of CPU 31xC

CPU 312C

The integrated inputs and outputs of this CPU have the following addresses:

Table 7- 1 Integrated I/Os of CPU 312C

Inputs / outputs	Default addresses	Comments
10 digital inputs	124.0 to 125.1 of which 8 Inputs are for technological functions: 124.0 to 124.7	All digital inputs can be assigned an interrupt function.
6 digital outputs	124.0 to 124.5 of which 2 inputs are for technological functions: 124.0 to 124.1	Optional technological functions: <ul style="list-style-type: none"> • Counting • Frequency measurement • Pulse width modulation

CPU 313C

Addresses of the integrated I/Os of this CPU:

Table 7- 2 Integrated I/Os of CPU 313C

Inputs / outputs	Default addresses	Comments
24 digital inputs	124.0 to 126.7 of which 12 inputs are for technological functions: 124.0 to 125.0 125.4 to 125.6	All digital inputs can be assigned an interrupt function. Optional technological functions:
16 digital outputs	124.0 to 125.7 of which 3 inputs are for technological functions: 124.0 to 124.2	<ul style="list-style-type: none"> • Counting • Frequency measurement • Pulse width modulation
4 + 1 analog inputs	752 to 761	
2 analog outputs	752 to 755	

CPU 313C-2 PtP and CPU 313C-2 DP

Addresses of the integrated I/Os of these CPUs:

Table 7- 3 Integrated I/Os of CPU 313C-2 PtP/DP

Inputs / outputs	Default addresses	Comments
16 digital inputs	124.0 to 125.7 of which 12 inputs are for technological functions: 124.0 to 125.0 125.4 to 125.6	All digital inputs can be assigned an interrupt function. Optional technological functions:
16 digital outputs	124.0 to 125.7 of which 3 inputs are for technological functions: 124.0 to 124.2	<ul style="list-style-type: none"> • Counting • Frequency measurement • Pulse width modulation

CPU 314C-2 PtP and CPU 314C-2 DP

Addresses of the integrated I/Os of these CPUs:

Table 7- 4 Integrated inputs/outputs of CPUs 314C-2 PtP and 314C-2 DP

Inputs / outputs	Default addresses	Comments
24 digital inputs	124.0 to 126.7 of which 16 inputs are for technological functions: 124.0 to 125.7	All digital inputs can be assigned an interrupt function. Optional technological functions: <ul style="list-style-type: none"> • Counting • Frequency measurement • Pulse width modulation • Positioning
16 digital outputs	124.0 to 125.7 of which 4 inputs are for technological functions: 124.0 to 124.3	
4 + 1 analog inputs	752 to 761	
2 analog outputs	752 to 755	

CPU 314C-2 PN/DP

The integrated inputs and outputs of this CPU have the following addresses:

Table 7- 5 Integrated inputs/outputs of the CPU 314C-2 PN/DP

Inputs/outputs	Default addresses	Comments
24 digital inputs	136.0 to 138.7 of which 16 Inputs are for technological functions: 136.0 to 137.7	All digital inputs can be assigned an interrupt function. Optional technological functions: <ul style="list-style-type: none"> • Counting • Frequency measurement • Pulse width modulation • Positioning
16 digital outputs	136.0 to 137.7 of which 4 inputs are for technological functions: 136.0 to 136.3	
4 + 1 analog inputs	800 to 809	
2 analog outputs	800 to 803	

Special features

You cannot influence outputs with transfer instructions if they are assigned to technological functions.

I/Os not configured for technological functions can be used as standard I/Os.

7.3 Addressing on PROFIBUS DP

Overview

The corresponding DP slaves must be commissioned for operation on PROFIBUS DP in order to enable addressing of distributed I/O in the user program.

This commissioning includes

- the assignment of PROFIBUS addresses to DP slaves
- the assignment of address ranges to the input/output modules or the slots in order to enable their addressing in the user program. the assignment of a diagnostic address to slots which do not contain user data.

This applies likewise when the CPU is operated as DP slave.

For more information about the commissioning of the CPUs as DP master or DP slave, refer to chapter: Commissioning PROFIBUS DP (Page 166).

User-specific addressing of distributed PROFIBUS IO

Distributed PROFIBUS DP IO requires user-specific addressing.

For more information, refer to chapter: User-specific addressing of modules (Page 129).

Addressing consistent user data areas

The table below shows items to be taken into consideration in terms of communication in a PROFIBUS DP master system when transferring I/O areas with "Total length" consistency.

Rule for 1 to 32 bytes data consistency on PROFIBUS DP:
The address range of consistent data in the process image is updated automatically. You can also use SFC14 "DPRD_DAT" and SFC15 "DPWR_DAT" to read and write consistent data. SFC14 and SFC15 are required to read and write consistent data of address ranges which are not available in the process image. The length of areas with "Total length" consistency accessed by the SFC must match the programmed range. Direct access to consistent areas is also possible (L PEW or T PAW, for example). PROFIBUS DP supports the transfer of up to 32 bytes of consistent data.

7.4 Addressing PROFINET IO

Overview

The corresponding I/O devices must be commissioned for operation on PROFINET in order to enable addressing of distributed peripherals on PROFINET IO in the user program.

This commissioning includes

- the assignment of address ranges to the input/output modules or the slots/subslots in order to enable their addressing in the user program. the assignment of a diagnostic address to slots which do not contain user data.
- The definition of device numbers and names for the IO devices
- the definition of I/O device names in order to enable the assignment of IP addresses and access to the IO devices by the CPU 31x PN/DP operated as IO controller.

Note

Naming IO devices after "Device replacement without removable medium"

If the functionality "Device replacement without removable medium" is configured in HW Config, IO devices can be replaced without the user having to assign a name. To do so, the IO device has to be reset to the state of delivery by using "Reset to factory setting".

Note

Use different method to obtain IP address parameters/device names (PROFINET CPUs)

- IP address parameters/device name via DCP:
IP address parameters/device name are assigned by means of DCP (Discovery and Configuration Protocol). This can be achieved in two ways:
 - using a setup tool such as PST or STEP 7, for example, via "Edit Ethernet node"
 - using the higher-level controller, provided the CPU is operated as an I device.
- IP address parameters/device name via user program:
The IP address parameters and/or device names are assigned in the user program of the CPU (using SFB 104)

For more information about the commissioning of the CPU as IO controller, refer to chapter Commissioning PROFINET IO (Page 180)

User-specific addressing of distributed PROFINET IO

Distributed peripherals on PROFINET IO require user-specific addressing.

For more information, refer to chapter User-specific addressing of modules (Page 129).

Addressing consistent user data areas

The table below shows items to be taken into consideration in terms of communication in a PROFINET IO system when transferring I/O areas with "Total length" consistency.

Rule for 1 to 1024 bytes data consistency on PROFINET IO:
<p>The address range of consistent data in the process image is updated automatically.</p> <p>You can also use SFC14 "DPRD_DAT" and SFC15 "DPWR_DAT" to read and write consistent data. SFC14 and SFC15 are required to read and write consistent data of address ranges which are not available in the process image.</p> <p>The length of areas with "Total length" consistency accessed by the SFC must match the programmed range.</p> <p>Direct access to consistent areas is also possible (L PEW or T PAW, for example).</p> <p>PROFINET IO supports the transfer of up to 1024 bytes of consistent data.</p>

7.5 Assigning IP address parameters and the device name

IP address parameters/device name

Similar to any other PROFINET device, the CPU (or its PROFINET interface) also needs the IP address parameters and device name for communication via PROFINET.

The IP address parameters consist of three sections:

- IP address
- Subnet mask
- Router address

Retentivity of IP address parameters and device names

The retentivity of IP address parameters and device names depends on the way it is assigned. The non-retentive, temporary assignment means that:

- IP address parameters and device names are valid until the next POWER OFF or memory reset. After POWER OFF/POWER ON or memory reset, the CPU can be reached at its MAC address only.
- Loading a temporary IP address also deletes non-retentive IP address parameters from memory.

Assigning IP address parameters and device names

The following methods are available for the assignment of IP address parameters and device names:

Assigning IP address parameters and device names		Retentivity
Default method: Permanent assignment in STEP 7	IP address parameters/device names are assigned permanently in the <i>STEP 7</i> configuration. The IP address parameters/device names are saved to retentive memory on the CPU along with the download of configuration data to the CPU.	Data is retentive: <ul style="list-style-type: none"> • on POWER OFF/ POWER ON • after memory reset
Permanent assignment with the settings "Use different method to obtain IP address parameters/ device names"	IP address parameters/device names are assigned by means of DCP (Discovery and Configuration Protocol): <ul style="list-style-type: none"> • Using a setup tool such as PST, or in <i>STEP 7</i>, for example, using the "Edit Ethernet nodes" function. • By the higher-level IO controller, provided the CPU is operated as intelligent device with prioritized power up. 	<ul style="list-style-type: none"> • after the configuration data was deleted (SDBs) • after the MMC was removed
Temporary assignment in STEP 7	IP address parameters/device names are assigned by means of DCP (Discovery and Configuration Protocol): <ul style="list-style-type: none"> • For automatic IP address assignments via "Available nodes" in <i>STEP 7</i>, if the CPU does not yet have an IP address. 	Data is not retentive
Temporary assignment with the setting "Use different method to obtain IP address parameters/ device names"	IP address parameters/device names are assigned by means of DCP (Discovery and Configuration Protocol): <ul style="list-style-type: none"> • If not operated with prioritized power up, an intelligent device is assigned the IP address by the higher-level controller. 	
Assignment in the user program	IP address parameters/device names are assigned in the user program using SFB 104. The retentivity of IP address parameters/device names can be specified in a corresponding parameter data record.	Retentivity in accordance with specifications in the parameter data record

Resetting retentive IP address parameters and device names

Retentive IP address parameters and device names can be reset as follows:

- With "Reset to factory settings"
- With a firmware update

NOTICE
<ul style="list-style-type: none">• The temporary assignment of IP address parameters/device names resets all retentive IP address parameters/device names in memory.• During the permanent assignment of IP address parameters/device names, the parameters previously saved to retentive memory will be replaced with the new parameters.

NOTICE
Reusing devices Always perform a "Reset to factory settings" before you install a device that contains retentive IP address parameters/device names in other subnets/systems, or before you put it on shelf.

Reference

For more information about IP address assignments for the intelligent device, refer to the PROFINET System Description (<http://support.automation.siemens.com/WW/view/en/19292127>).

Commissioning

8.1 Overview

This section contains important notes on commissioning which you should strictly observe in order to avoid injury or damage to machines.

Note

Your commissioning phase is determined primarily by your application, so we can only offer you general information, without claiming completeness of this topic.

Reference

Note the information about commissioning provided in the descriptions of your system components and devices.

8.2 Commissioning procedure

8.2.1 Procedure: Commissioning the hardware

Hardware requirements

- S7-300 is installed.
- S7-300 is wired.

Prepare the interfaces for a networked S7-300 as follows:

- MPI/ PROFIBUS
 - The MPI/PROFIBUS addresses are set.
 - The terminating resistors at the segment boundaries are enabled.
- PROFINET
 - The integrated PROFINET interface of CPU 31x PN/DP is configured in STEP 7 (IP address and device name are set, for example, in HW Config).
 - The CPU is connected to the subnet.

Recommended procedure: Hardware

The S7-300 system can be very large and extremely complex due to its modular structure and versatile expansion options. It is therefore inappropriate to initially start up an S7-300 with multiple racks and all inserted (installed) modules. Rather, we recommend a step-by-step commissioning procedure.

We recommend the following initial commissioning procedure for an S7-300:

Table 8- 1 Recommended commissioning procedure: Hardware

Tasks	Comments	Information can be found
An installation and wiring check according to checklist	-	<i>in the chapter: Checklist for commissioning</i>
Disconnecting drive aggregates and control elements	This prevents negative effects on your system as a result of program errors. Tip: By redirecting data from your outputs to a data block, you can always check the status at the outputs	-
Preparing the CPU	Connecting the PG	<i>in the chapter: Connecting the programming device (PG).</i>
Central unit (CU): commission the CPU and power supply, check the LEDs	Commission the CU with inserted power supply module and CPU. First, switch on the expansion devices (EMs) which are equipped with their own power supply module, and then switch on the power supply module of the CU.	<i>in the chapter: Initial power on</i>
	Check the LED displays on both modules.	<i>in the chapter: Debugging functions, diagnostics and troubleshooting</i>
Reset CPU memory and check the LEDs	-	<i>in the chapter: CPU memory reset by means of mode selector switch</i>
CU: commission the remaining modules	Insert additional modules into the CU and commission these, working successively.	in the <i>Module specifications Manual</i>
Expansion module (EM): Interconnect	Interconnect the CU with EMs as required: Insert only one send IM into the CU, and insert the matching receive IM into into the EM.	<i>in the chapter: Installation</i>
EM: Commissioning	Insert additional modules into the EMs and commission these, working in successively.	See above.

 DANGER
<p>Proceed step-by-step. Do not go to the next step unless you have completed the previous one without error/error message.</p>

Reference

Important notes can also be found in the section *Debugging Functions, Diagnostics and Troubleshooting*.

See also

Procedure: Software commissioning (Page 143)

8.2.2 Procedure: Software commissioning

Requirements

- You must have installed and wired up your S7-300.
- You are using the current programming package of STEP 7 in order to utilize the complete functional scope of your CPU.
- In case of networking of the S7-300 with MPI or PROFIBUS
 - The MPI/PROFIBUS addresses are configured
 - You have switched on the terminating resistors at the segment borders.
- In case of networking of the S7-300 with PROFINET
 - The integrated PROFINET interface of CPU 31x PN/DP is configured in STEP 7 (IP address and device names are set in HW Config)
 - The CPU is connected to the subnet.

Note

Observe the procedure for commissioning the hardware.

Recommended procedure: Software

Table 8-2 Recommended commissioning procedure - Part II: Software

Tasks	Comments	Information can be found...
<ul style="list-style-type: none"> Switch on the PG and run SIMATIC Manager Download the configuration and the program to the CPU 	-	In the <i>STEP 7</i> Programming Manual
Debugging the I/Os	Helpful functions are here: <ul style="list-style-type: none"> Monitoring and modifying variables Testing with program status Forcing Controlling outputs in STOP mode (PO enable) Tip: Test the signals at the inputs and outputs. Use the simulation module SM 374, for example.	In the <i>STEP 7</i> Programming Manual in the chapter: <i>Debugging functions, diagnostics and troubleshooting</i>
Commissioning PROFIBUS DP or Ethernet	-	in the chapter: <i>Commissioning PROFIBUS DP</i> in the chapter: <i>Configuring PROFINET interface X2</i>
Commissioning PROFINET IO		in the <i>PROFINET System Description System Manual</i>
Connect the outputs	Commissioning the outputs successively.	-

 DANGER
Proceed step-by-step. Do not go to the next step unless you have completed the previous one without error/error message.

Reaction to errors

React to errors as follows:

- Check the system with the help of the check list in the chapter below.
- Check the LED displays on all modules. For information on their meaning, refer to the chapters describing the relevant modules.
- If required, remove individual components to trace the error.

Reference

Important notes can also be found in the section *Debugging Functions, Diagnostics and Troubleshooting*.

See also

Procedure: Commissioning the hardware (Page 141)

8.3 Commissioning check list

Introduction

After you have installed and wired your S7-300, we advise you to check all previous steps once again.

The check list tables below are a guide for your examination of the S7-300. They also provide cross-references to chapters containing additional information on the relevant topic.

Racks

Points to be examined are in the manual	S7-300: Installation in chapter
Are the rails mounted firmly to the wall, in the frame or in the cabinet?	Configuring, Installation
Have you maintained the free space required?	Configuring, Installation
Are the cable ducts installed properly?	Configuring
Is the air circulation OK?	Installing

Concept of grounding and chassis ground

Points to be examined are in the manual	S7-300: Installation in chapter
Have you established a low-impedance connection (large surface, large contact area) to local ground?	Configuring, Appendix
Are all racks (rails) properly connected to reference potential and local ground (direct electrical connection or ungrounded operation)?	Configuring, Wiring, Appendix
Are all grounding points of electrically connected modules and of the load power supply units connected to reference potential?	Configuring, Appendix

Module installation and wiring

Points to be examined are in the manual	S7-300: Installation in chapter
Are all modules properly inserted and screwed in?	Installing
Are all front connectors properly wired, plugged, screw-tightened or latched to the correct module?	Installation, Wiring

Mains voltage

Points to be examined	S7-300: Installation in chapter	See manual; Section
Is the correct mains voltage set for all components?	Wiring	Module data

Power supply module

Points to be examined	S7-300: Installation in chapter	See manual; Section
Is the mains plug wired correctly?	Wiring	-
Is mains voltage connected?	-	-

8.4 Commissioning the Modules

8.4.1 Inserting/replacing a Micro Memory Card

SIMATIC Micro Memory Card (MMC) as memory module

The memory module used on your CPU is a SIMATIC Micro Memory Card. You can set up the SIMATIC Micro Memory Card as a load memory or a portable data medium.

Note

A SIMATIC Micro Memory Card must be inserted for CPU operation.

Note

The CPU goes into STOP and requests a memory reset when you remove the SIMATIC MMC while the CPU is in RUN state.

 CAUTION

Data on a SIMATIC Micro Memory Card can be corrupted if you remove the card while it is being accessed by a write operation. You may then have to delete the SIMATIC Micro Memory Card on the PG or format it in the CPU.

DO NOT remove the SIMATIC Micro Memory Card when the system is in RUN mode; always shut down power or set the CPU to STOP mode when no PG write access is taking place. When the CPU is in STOP mode and you cannot not determine whether or not a PG is writing to the card (e.g. load/delete block), disconnect the communication lines.

 WARNING

Make sure that the SIMATIC Micro Memory Card to be inserted contains a user program which is suitable for the CPU (system). The wrong user program may have fatal processing effects.

Inserting/replacing the SIMATIC Micro Memory Card

1. Switch the CPU to STOP mode.
2. Is a SIMATIC Micro Memory Card inserted?

If yes, ensure that no write operations are running on the PG (such as loading a block). If you cannot ensure this state, disconnect all communication lines of the CPU.

Press the ejector and remove the SIMATIC MMC.

The frame of the module slot is equipped with an ejector for removing the SIMATIC MMC (see CPU 31xC and CPU 31x Manual, Technical Data, *Chapter CPU31x Operator Control and Display Elements*).

You need a small screwdriver or ball-point pen to eject the SIMATIC Micro Memory Card.

3. Insert the ("new") SIMATIC MMC into the card slot with its beveled edge facing the ejector.
4. Carefully push the SIMATIC MMC into the CPU slot to engage the interlock.
5. Reset CPU memory (*see Resetting CPU memory by means of mode selector switch*)

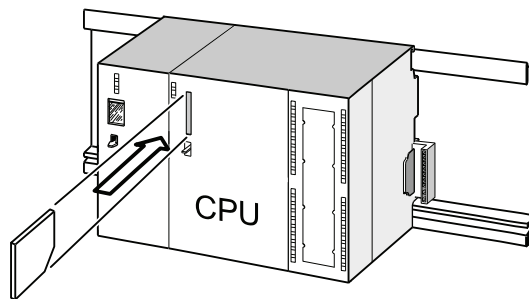

Inserting and removing a SIMATIC MMC when CPU power is switched off

After you replaced a SIMATIC MMC in POWER OFF state, the CPUs

- automatically detect a physically identical SIMATIC MMC with changed content
- automatically detect a new MMC with contents to the previous SIMATIC MMC

It automatically performs a CPU memory reset after POWER ON.

Reference

- Chapter *Properties of the SIMATIC Micro Memory Card*, CPU 31xC and CPU 31x Manual, Technical data
- Chapter *Technical data of the SIMATIC Micro Memory Card (MMC)*, CPU 31xC and CPU 31x Manual, Technical data

8.4.2 Initial power on

Requirements

- You must have installed and wired up the S7-300.
- Insert the Micro Memory Card into the CPU.
- Your CPU's mode selector switch must be set to STOP.

Initial power on of a CPU with Micro Memory Card

Switch on the PS 307 power supply module.

Result:

- The 24 VDC LED is lit on the power supply module.
- On the CPU
 - the 5 VDC LED is lit.
 - The STOP LED flashes at 2 Hz while the CPU executes an automatic memory reset.
 - The STOP LED is lit after memory reset.

8.4.3 CPU memory reset by means of mode selector switch

When to reset CPU memory

You reset CPU memory

- in order to clear all retentive memory bits, timers and counters, and to initialize work memory with the start values of the retentive DBs in load memory.
- if the new retentive new memory bits, timers and counters downloaded to the CPU user program using the "Download user program to Memory Card" function are liable to cause unwanted reactions.

Reason: the "Download user program to Memory Card" function does not delete any retentive memory areas.

- if the CPU requests a memory reset, indicated by the STOP LED flashing at 0.5 Hz intervals.

Table 8- 3 Possible reasons of a CPU request to reset memory

Causes of a CPU request to reset memory	Special features
The SIMATIC MMC has been replaced.	–
RAM error in CPU	–
Insufficient work memory for loading all user program blocks from a SIMATIC MMC.	CPU with inserted SIMATIC Micro Memory Card: Recursive request of a CPU memory reset.
Attempts to load faulty blocks; if a wrong instruction was programmed, for example.	For additional information on the behavior of the SIMATIC MMC during CPU memory reset, refer to the CPU 31xC and CPU 31x Manual, Technical data, <i>Memory Reset and Restart</i>

How to reset memory

There are two ways to reset CPU memory:

CPU memory reset using the mode selector switch	CPU memory reset using the PG
... is described in this chapter.	... is only possible when the CPU is in STOP mode (see <i>STEP 7 Online Help</i>).

Resetting CPU memory using the mode selector switch

The table below shows the steps in resetting CPU memory.

Table 8- 4 Procedure for CPU memory reset

Step	Reset CPU memory
1	Turn the key to STOP position ①.
2	Turn the key to MRES position. Hold the key in this position until the STOP LED lights up for the second time and remains on (this takes 3 seconds) ②. Now release the key.
3	You must turn the key to MRES position again within 3 seconds and hold it there until the STOP LED flashes (at 2 Hz) ③. You can now release the switch. When the CPU has completed memory reset, the STOP LED stops flashing and remains lit. The CPU has reset the memory.

The procedure described earlier is only required to reset CPU memory when the CPU has not requested (indicated by slow flashing of the STOP LED) a memory reset. If the CPU requests a memory reset you only have to briefly set the mode selector switch to the MRES position in order to initiate the memory reset.

The figure below shows how to use the mode selector switch to reset CPU memory:

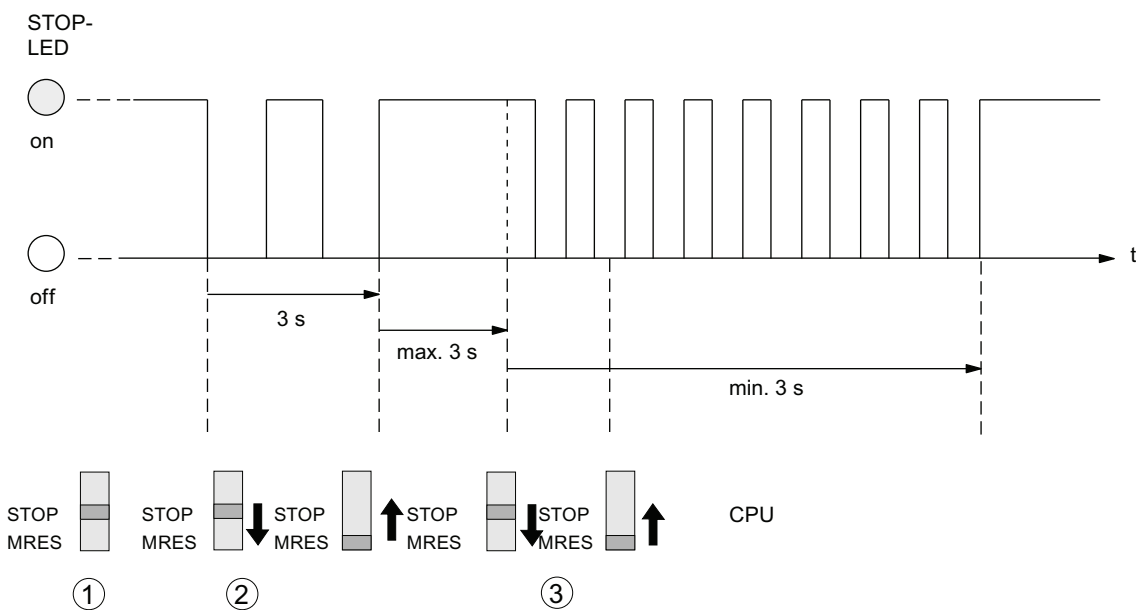

You may have to format the SIMATIC MMC if memory was successfully reset and the CPU once again requests a memory reset (*see Formatting the SIMATIC Micro Memory Card*).

STOP LED does not flash during the memory reset

What should I do if the STOP LED does not flash during the memory reset or if other LEDs are lit?

1. You must repeat steps ② and ③.
2. If the CPU still does not reset memory, evaluate the diagnostic buffer of the CPU.

What happens during a CPU memory reset?

Table 8- 5 Internal CPU events on memory reset

Event	Action in CPU
CPU activities	1 The CPU deletes the entire user program in the main memory.
	2 The CPU erases the retentive user data (bit memories, times, counters and DB contents)
	3 The CPU tests its own hardware.
	4 The CPU copies the runtime-relevant content of the SIMATIC Micro Memory Card (load memory) to work memory. Tip: If the CPU is unable to copy the contents from the SIMATIC MMC and requests a memory reset: <ul style="list-style-type: none"> • Remove the SIMATIC Micro Memory Card. • Reset CPU memory. • Read the diagnostic buffer. If the IP address and device name were not retentive (depending on the assignment mode): Assign a temporary IP address to the CPU and then read out the diagnostic buffer, or determine the MAC address of the CPU in SIMATIC Manager under "Available nodes". If the Ethernet interface of the programming device is set to "TCP/IP (Auto)", you can also use this available MAC address to read the diagnostic buffer, because STEP 7 will then assign a temporary IP address.
Memory contents after reset	The user program is once again transferred from the SIMATIC MMC to work memory. Memory utilization is indicated accordingly.
Data retained	<ul style="list-style-type: none"> • Data in the diagnostic buffer. After POWER OFF/POWER ON, only the last 100 entries in the diagnostic buffer are retentive. You can use the programming device to read the diagnostic buffer (see the <i>STEP 7 Online Help</i>).
	<ul style="list-style-type: none"> • The MPI interface parameters (MPI address and highest MPI address, transmission rate, configured MPI addresses of CPs/FMs in an S7300).
	<ul style="list-style-type: none"> • The same applies to CPU 314C-2 PN/DP, CPU 315-2 PN/DP, CPU 317, CPU 319 if the MPI/DP interface of the CPU is programmed for operation as DP interface (PROFIBUS address, highest PROFIBUS address, baud rate, configured as active or passive interface).
	<ul style="list-style-type: none"> • Parameters of the PROFINET interface: IP address parameters/device name (depending on the assignment mode, see chapter: Assigning IP address parameters and the device name (Page 137)).
	The time.
	Contents of run-time meter.

Note**Communication shutdown during memory reset on PROFINET CPUs with integrated switch**

Note that the PROFINET interface and the integrated switch are shut down when you reset memory on this CPU.

During the memory reset on a CPU configured within a line structure, communication via the CPU integrated switch to downstream devices is shut down.

After memory reset, the PROFINET interface is not restarted unless the interface parameters were saved to retentive memory.

The integrated switch is always restarted and can resume communication on completion of the CPU memory reset.

Special feature: Interface parameters

The following parameters hold a special position when CPU memory is reset.

- Parameters of an MPI or MPI/DP interface
- Parameters of a PROFINET interface

The table below describes which interface parameters are valid after a CPU memory reset.

CPU memory reset ...	PROFINET interface parameters ...	MPI/DP parameters ...
with inserted SIMATIC Micro Memory Card	... which are on the SIMATIC Micro Memory Card or integrated read-only load memory are valid.	
	If no parameters are stored (SDB), the previously set parameters remain valid, provided they were saved to retentive memory (depending on the assignment mode, see chapter: Assigning IP address parameters and the device name (Page 137))	If no parameters are stored (SDB), the previously set parameters remain valid (not valid for an interface with DP function only).
without inserted SIMATIC Micro Memory Card	... the previously set parameters remain valid, provided they were saved to retentive memory (depending on the assignment mode, see chapter: Assigning IP address parameters and the device name (Page 137))	... are retained and remain valid (not valid for an interface with DP function only).

8.4.4 Formatting the Micro Memory Card

Situations which require formatting of the SIMATIC Micro Memory Card:

- The SIMATIC Micro Memory Card module type is not a user module
- The SIMATIC Micro Memory Card is not formatted
- The SIMATIC Micro Memory Card is defective
- Invalid content of the SIMATIC Micro Memory Card
The content of the SIMATIC Micro Memory Card has been marked invalid
- The "Download user program" operation was interrupted as a result of Power Off.
- The "Write to EPROM" operation was interrupted as a result of Power Off.
- Error when evaluating the module content during CPU memory reset.
- Formatting error, or formatting failed.

If one of these errors has occurred, the CPU prompts you for yet another memory reset, even after a memory reset operation has been performed. The contents of the SIMATIC MMC are retained until it is formatted, unless the "Download user program" or "Write to EPROM" operation was interrupted due to Power Off.

The SIMATIC Micro Memory Card is only formatted if a specific reason is given (see above). It is not formatted, for example, when the CPU requests a memory reset after module replacement. In this case, a switch to MRES triggers a normal memory reset for which the module content remains valid.

How to format your SIMATIC Micro Memory Card

If the CPU has requested a memory reset (STOP LED flashing slowly) you can format the SIMATIC MMC using the mode selector switch as described below:

1. Toggle the switch to the MRES position and hold it there until the STOP LED lights up and remains on (after approx. 9 seconds).
2. Within the next three seconds, release the switch and toggle it once again to MRES position. The STOP LED flashes to indicate that formatting is in progress.

Note

Always perform these steps within the specified time, for the SIMATIC Micro Memory Card will otherwise not be formatted and returns to memory reset status.

See also

CPU memory reset by means of mode selector switch (Page 150)

8.4.5 Connecting the programming device (PG)

8.4.5.1 Connect PG/PC to the integrated PROFINET interface of the CPU 31x PN/DP

Requirement

- CPU with integrated PROFINET interface (e.g., CPU 317-2 PN/DP)
- PG/PC with network card

Connect PG/PC to the integrated PROFINET interface of the CPU 31x PN/DP

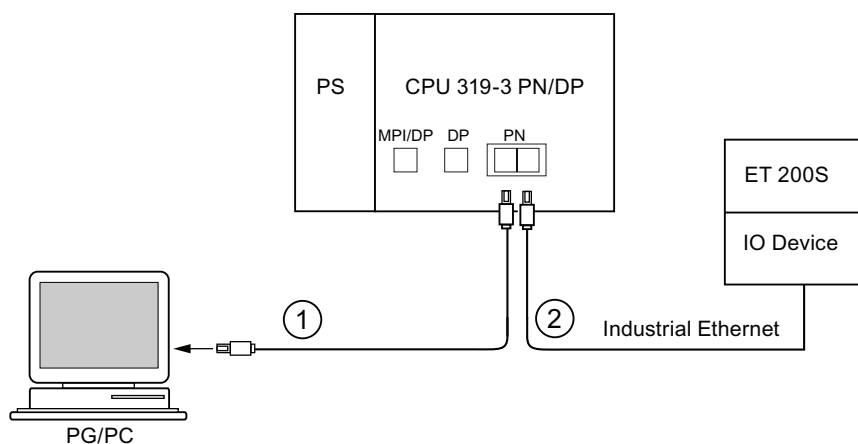

Number Meaning

- | | |
|---|--|
| ① | Using a preassembled twisted-pair cable, connect the programming device/PC to Port 1 of the PROFINET interface of the CPU. |
| ② | Using a twisted-pair cable, connect the IO device to Port 2 of the PROFINET interface of the CPU. |

Reference

- For information on PROFINET, refer to the *PROFINET System Description*.
- For information on passive network components, refer to the manual *SIMATIC NET: Twisted Pair and Fiber-Optic Networks*.

See also

Configuring the PROFINET IO system (Page 182)

8.4.5.2 Connecting the PG to a node

Requirement

The PG must be equipped with an integrated MPI interface or an MPI card in order to connect it via MPI.

Connecting a PG to the integrated MPI interface of the CPU

Interconnect the PG with the MPI interface of your CPU by way of a PG patch cable ①. You can use a self-made PROFIBUS bus cable with bus connectors. The figure below illustrates the connection between the PG and the CPU.

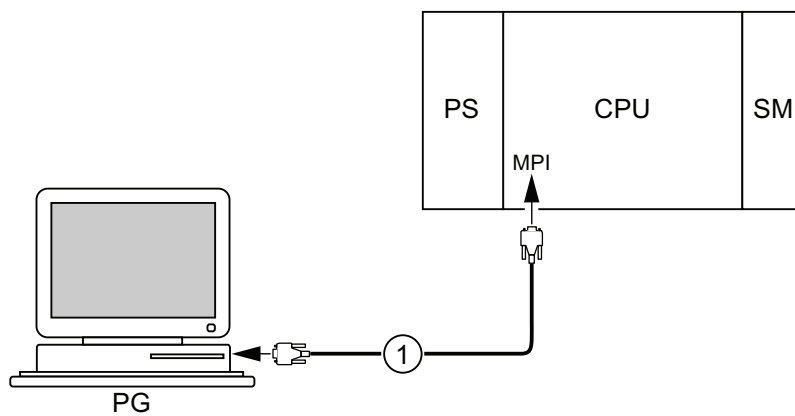

Number	Description
①	PG cable used to interconnect the PG with the CPU

Procedure for PROFIBUS DP

The procedure is basically the same for PROFIBUS DP, if the CPU interface is set to PROFIBUS DP mode.

8.4.5.3 Connecting the PG to several nodes

Requirement

The PG must be equipped with an integrated MPI interface or an MPI card in order to connect it to an MPI.

Connecting the PG to several nodes

Use bus connectors to connect a PG which is permanently installed on the MPI subnet to the other nodes of the MPI subnet.

The figure below shows two networked S7-300s which are interconnected by means of bus connectors.

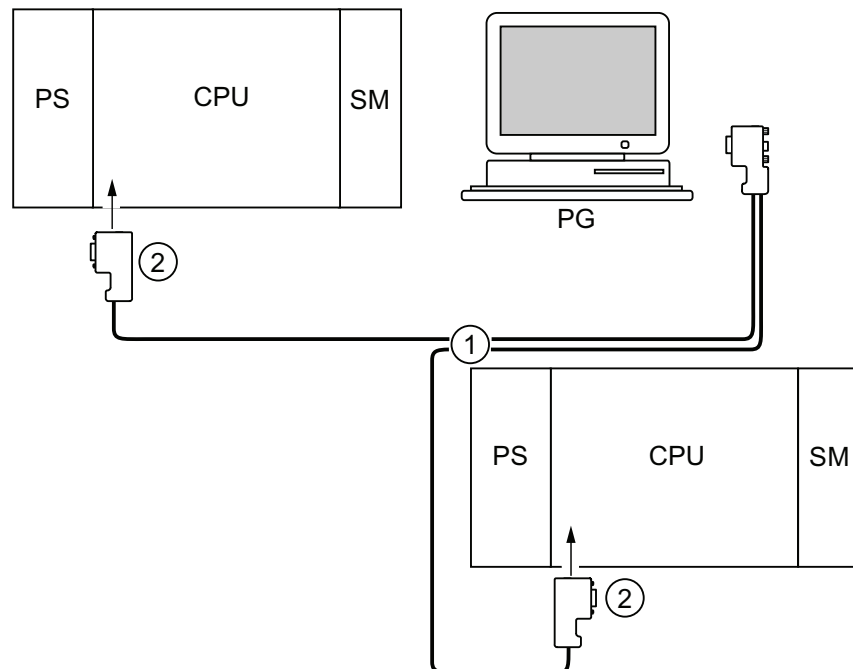

Numb	Description
er	
①	PROFIBUS bus cable
②	Connectors with enabled terminating resistors

8.4.5.4 Using the PG for commissioning or maintenance

Requirement

The PG must be equipped with an integrated MPI interface or an MPI card in order to connect it to an MPI.

Using the PG for commissioning or maintenance

Use a stub cable to connect the commissioning and maintenance PG to the other subnet nodes. The bus connector of these nodes must be equipped with a PG socket.

The figure below shows the interconnection of two networked S7-300 and a PG.

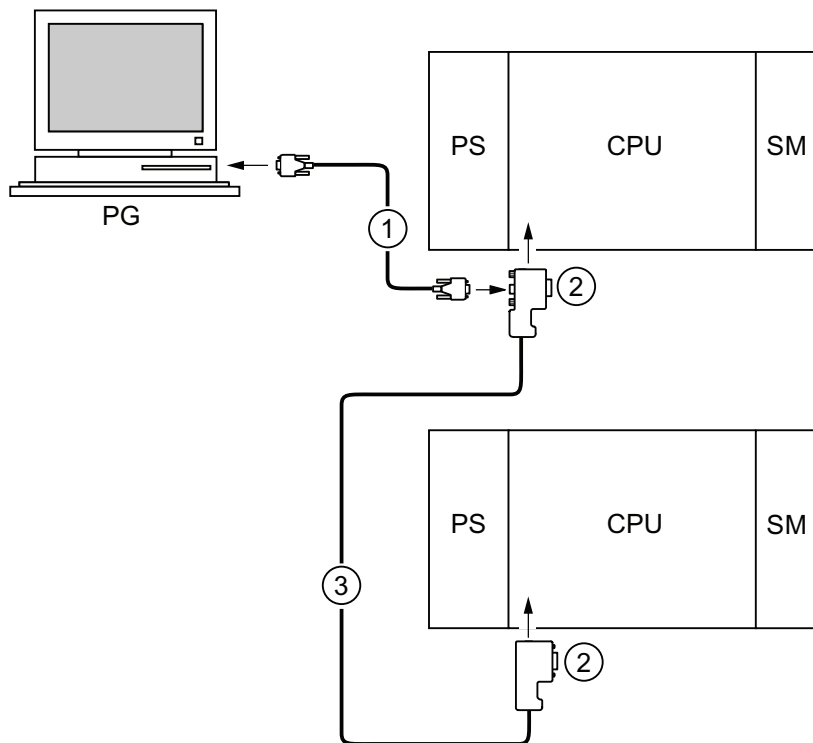

Number	Description
①	Stub cable for connection between programming device and CPU
②	Connectors with enabled terminating resistors
③	PROFIBUS bus cable for linking both CPUs

MPI addresses for service PGs

If there is no stationary PG, we recommend:

To connect a PG to an MPI subnet with "unknown" node addresses, set the following addresses on the service PG:

- MPI address: 0
- Highest MPI address: 126

IN STEP 7, you then determine the highest MPI address on the MPI subnet and match the highest MPI address in the PG to that of the MPI subnet.

See also

Procedure: Commissioning the hardware (Page 141)

Procedure: Software commissioning (Page 143)

8.4.5.5 Connecting a PG to ungrounded MPI nodes (not CPU 31xC)

Requirement

The PG must be equipped with an integrated MPI interface or an MPI card in order to connect it to an MPI.

Connecting a PG to ungrounded nodes on an MPI subnet (not CPU 31xC)

Connecting a PG to ungrounded nodes

Always use an ungrounded PG to connect to ungrounded MPI subnet nodes or to ungrounded S7-300 PLCs.

Connecting a grounded PG to the MPI

You want to operate with ungrounded nodes. If the MPI at the PG is grounded, you must interconnect the nodes and the PG with an RS485 repeater. You must connect the ungrounded nodes to bus segment 2 if the PG is connected to bus segment 1 (terminals A1 B1) or to the PG/OP interface (refer to chapter 9 in the *Module Data Manual*).

The figure below shows an RS485 repeater as interface between grounded and ungrounded nodes of an MPI subnet.

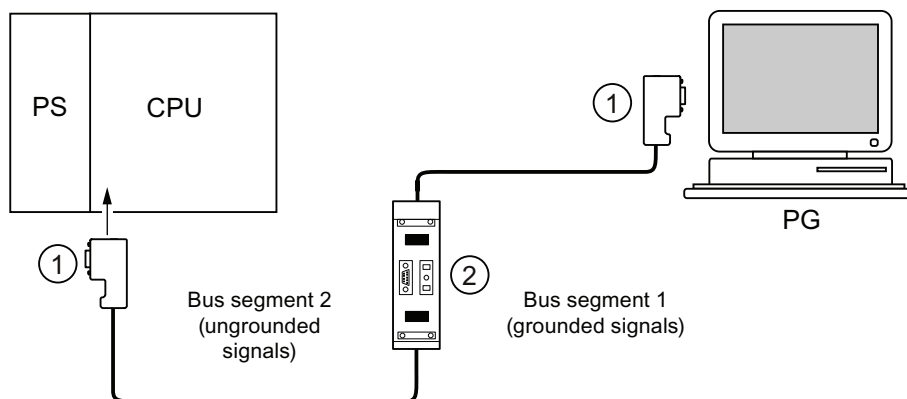

Number	Description
①	Connectors with enabled terminating resistors
②	RS485 Repeaters, with activated terminating resistors

See also

PROFINET cable lengths and network expansion (Page 85)

Network components of MPI/DP and cable lengths (Page 63)

8.4.6 Starting SIMATIC Manager

Introduction

SIMATIC Manager is a GUI for online/offline editing of S7 objects (projects, user programs, blocks, hardware stations and tools).

The SIMATIC Manager lets you

- manage projects and libraries,
- call STEP 7 tools,
- access the PLC (AS) online,
- edit Memory Cards.

Starting SIMATIC Manager

After installation, the **SIMATIC Manager** icon appears on the Windows desktop, and the Start menu contains entry **SIMATIC Manager** under **SIMATIC**.

1. Run SIMATIC Manager by double-clicking the icon, or from the Start menu (same as with all other Windows applications).

User interface

A corresponding editing tool is started up when you open the relevant objects. You start the program editor by double-clicking the program block you want to edit (object-oriented start).

Online Help

The online help for the active window is always called by pressing F1.

8.4.7 Monitoring and modifying inputs and outputs

The "Monitoring and modifying variable" tool

Using the STEP 7 "Monitoring and modifying variable" tool, you can

- monitor program variables in any format
- edit the variable status or contents in the CPU (modifying).

Creating a variable table

You have two options for creating a variable table (VAT):

- in the LAD/FBD/STL editor by selecting the **PLC > Monitor/Modify Variables** command
This table is also available directly online.
- in SIMATIC Manager with the **Blocks** container open via menu item **Insert New Object > Variable table**
This table created offline can be saved for future retrieval. You can also test it after switching to online mode.

VAT structure:

In the VAT, every address to be monitored or modified (e.g. inputs, outputs) occupies one row.

The meaning of the VAT columns is as follows:

Column text	This field ...
Address	contains the absolute address of the variable
Icon	contains the symbolic descriptor of the variable This is identical to the specification in the Symbol Table.
Symbol comment	shows the symbol comment of the Symbol Table
Status format	contains the default format setting, e.g. HEX. You can change the format as follows: <ul style="list-style-type: none"> • right-click in the format field. The Format List opens. or • left-click in the format field until the relevant format appears
Status value	shows the contents of the variable at the time of update
Modify value	is used to enter the new variable value (modify value)

Monitor variable

You have two options for monitoring variables:

- updating the status values once via menu item **Variable > Update Status Values**
or
- continuous update of status values via menu item **Variable > Monitor**

Modifying variable

To modify variables, proceed as follows:

1. Left-click the field **Modify value** of the relevant variable.
2. Enter the modify value according to the data type.
3. To update modify values once, select the menu item **Variable > Activate Modify Values**.

or

Enable modify values permanently via menu item **Variable > Modify**.

4. Use the **Monitor** test function to verify whether the modify value was entered in the variable.

Is the modify value valid?

You can disable the modify value entered in the table. An invalid value is displayed same as a comment. You can re-enable the modify value.

Only valid modify values can be enabled.

Setting the trigger points

Trigger points:

- The "Trigger point for monitoring" determines the time of update for values of variables to be monitored.
- The "Trigger point for modifying" determines the time for assigning the control values to the variables to be modified.

Trigger condition:

- The "Trigger condition for monitoring" determines whether to update values once when the trigger point is reached or continuously every time the trigger point is reached.
- The "Trigger condition for modifying" determines whether to assign control values once or permanently to the variables to be modified.

Start the settings of the trigger points in the "Monitoring and modifying variable" tool, **Variable > Set triggers ...** menu command.

Special features:

- If "Trigger condition for monitoring" is set to **once**, the menu items **Variable > Update Status Values** or **Variable > Monitor** have the same effect, namely a single update.
- If "Trigger condition for modifying" is set to **once**, the menu items **Variable > Update modify values** or **Variable > Modify** have the same effect, namely a single assignment.
- If trigger conditions are set to **permanent**, the said menu items have different effects as described above.
- If monitoring and modifying is set to the same trigger point, monitoring is executed first.
- If **Process operation** is set under **Debug > Mode**, value assignment does not take place in every cycle when **permanent modifying** is set.
Remedy: Use the **Force** test function.

Saving/opening the variable table

Saving the VAT

1. After aborting or completing a test phase, you can save the variable table to memory. The name of a variable table starts with the letters VAT, followed by a number from 0 to 65535; e.g. VAT5.

Opening VAT

1. Select the menu item **Table > Open**.
2. Select the project name in the **Open** dialog.
3. In the project window below, select the relevant program and mark the **Blocks** container.
4. In the block window, select the desired table.
5. Confirm with **OK**.

establishing a connection to the CPU

The variables of a VAT represent dynamic quantities of a user program. In order to monitor or modify variables it is required to establish a connection to the relevant CPU. Every variable table can be linked to another CPU.

In menu item **PLC > Connect to ...** , establish a connection to one of the following CPUs:

- configured CPU
- directly connected CPU
- available CPU ...

The table below lists the display of variables.

CPUs	The CPU variables are displayed, ...
configured CPU	in their S7 program (Hardware Station) in which the VAT is stored.
directly connected CPU	that is connected directly to the PG.
available CPU	that is selected in the dialog window. Use the menu items PLC > Connect to ... > Available CPU ... to connect to an available CPU. This can be used to connect to any CPU available on the network.

Modifying outputs in CPU STOP mode

The function **Enable PO** resets the output disable signal for the peripheral outputs (PO), thus enabling modifying of the PO in CPU STOP mode.

In order to enable the POs, proceed as follows:

1. In menu item **Table > Open the variable table (VAT)**, open the VAT that contains the PO you want to modify, or activate the window containing the corresponding VAT.
2. To modify the PO of the active VAT, select the CPU connection in menu command **PLC > Connect to ...**.
3. Use menu command **PLC > Operating Mode** to open the **Operating Mode** dialog and switch the CPU to STOP mode.
4. Enter your values in the "Modify value" column for the PO you want to modify.

Examples:

I/O output: POB 7 modify value: 2#0100 0011

POW 2 W#16#0027

POD 4 DW#16#0001

5. Select **Variable > Enable PO** to set "Enable PO" mode.
6. Modify the PO by selecting **Variable > Activate Modify Values**. "Enable PO" mode remains active until reset by selecting **Variable > Enable PO** to disable this mode.
"Enable PO" is also terminated when the connection to the programming device is canceled.
7. Return to step 4 if you want to set new values.

Note

For example, a message pops up to indicate a CPU mode transition from STOP to RUN or START-UP.

A message also pops up if you select the "Enable PO" function while the CPU is in RUN mode.

8.5 Commissioning PROFIBUS DP

8.5.1 Commissioning the PROFIBUS DP network

Requirements

Requirements for commissioning a PROFIBUS DP network:

- A PROFIBUS DP network is installed.
- You have configured the PROFIBUS DP network using STEP 7 Standard Package and have assigned a PROFIBUS DP address and the address space to all the participants.
- Note that you must also set address switches at some of the DP slaves (see the description of the relevant DP slave).
- Software requirements are shown in the table below, based on the CPU used:

Table 8- 6 Software requirements

CPU	Order number	Software required
313C-2 DP	6ES7313-6CG04-0AB0	STEP 7 as of V5.5 + SP1 or STEP 7 as of V5.3 + SP2 with HSP
314C-2 DP	6ES7314-6CH04-0AB0	
314C-2 PN/DP	6ES7314-6EH04-0AB0	STEP 7 as of V5.5 + SP1 or STEP 7 as of V5.5 + HSP
315-2 DP	6ES7315-2AH14-0AB0	STEP 7 as of V5.5 + SP1 or STEP 7 as of V5.2 + SP1 + HSP
315-2 PN/DP	6ES7315-2EH14-0AB0	STEP 7 as of V5.5 + SP1 or STEP 7 as of V5.5 + HSP
317-2 DP	6ES7317-2AK14-0AB0	STEP 7 as of V5.5 + SP1 or STEP 7 as of V5.2 + SP1 with HSP
317-2 PN/DP	6ES7317-2EK14-0AB0	STEP 7 as of V5.5 + SP1 or STEP 7 as of V5.5 + HSP
319-3 PN/DP	6ES7318-3EL01-0AB0	STEP 7 as of V5.5

DP address ranges of the CPUs

Table 8- 7 DP address ranges of the CPUs

Address range	313C-2 DP 314C-2 DP 315-2 DP 315-2 PN/DP	314C-2 PN/DP	317-2 DP 317-2 PN/DP 319-3 PN/DP
Entire address range of inputs and of outputs	2048 Byte	2048 Byte	8192 Byte
of these in the process image, for inputs and outputs respectively	Max. 2048 bytes	Max. 2048 bytes	Max. 8192 bytes
• Default	128 Byte	256 Byte	256 Byte

DP diagnostic addresses

DP diagnostic addresses occupy 1 byte per DP master and DP slave in the input address range. For example, at these addresses DP standard diagnostics can be called for the relevant node (LADDR parameter of SFC 13). The DP diagnostic addresses are specified in your configuration. If you do not specify any DP diagnostic addresses, STEP 7 assigns these DP diagnostic addresses in ascending order, starting at the highest byte address.

In the case of a CPU 31xC-2 DP, CPU 31x-2 DP or CPU 31x PN/DP assigned as a master, two different diagnostic addresses must be assigned for S7 slaves.

- Diagnostic address of the slave (address for slot 0)

At this address all slave events are reported in the DP master (Node representative), e.g. Node failure.

- Diagnostic address of the module (address for slot 2)

All module (CPU 313C-2 DP as I-Slave, for example) events are reported in the master (OB82) at this address. With a CPU as DP Slave, for example, diagnostic interrupts for operating mode transitions are reported at this address.

See also

Connecting the PG to a node (Page 156)

Connecting the PG to several nodes (Page 157)

8.5.2 Commissioning the CPU as DP master

Requirements for commissioning

- The PROFIBUS subnet has been configured.
- The DP slaves are ready for operation (see relevant DP slave manual).
- In order to operate the MPI/DP interface as DP interface, it must be configured accordingly (only CPU 314-2 PN/DP, CPU 315-2 PN/DP, CPU 317 and CPU 319).
- You must configure the CPU as DP master prior to commissioning. That is, in STEP 7 you have to
 - configure the CPU as a DP master,
 - assign a PROFIBUS address to the CPU,
 - assign a master diagnostic address to the CPU,
 - integrate the DP slaves into the DP master system.

Is the DP CPU a DP slave?

If so, this DP slave appears in the PROFIBUS DP catalog as **configured station**. In the DP master, assign a slave diagnostic address to this DP slave CPU. You must interconnect the DP master with the DP slave CPU and specify the address ranges for data exchange with the DP slave CPU.

Commissioning

Commission the DP CPU as a DP master in the PROFIBUS subnet as follows:

1. Download the PROFIBUS subnet configuration created with STEP 7 (preset configuration) from the PG to the DP CPU.
2. Switch on all of the DP slaves.
3. Switch the DP CPU from STOP to RUN.

Startup of DP CPU as DP master

During startup, the DP CPU checks the configured expected configuration of its DP master system against the actual configuration.

If preset configuration = actual configuration, the CPU switches to RUN mode.

If the preset configuration \neq to the actual configuration, the configuration of parameter **Startup if preset configuration \neq actual configuration** determines the startup behavior of the CPU.

Startup when the preset configuration \neq actual configuration = yes (default setting)	Startup when the preset configuration \neq actual configuration = no
DP CPU switches to RUN. (BUSF LED flashes if any of the DP slaves cannot be addressed)	DP CPU remains in STOP mode, and the BUS LED flashes after the set Monitoring time for transfer of parameters to modules . The flashing BUSF LED indicates that at least one DP slave cannot be accessed. In this case, check whether all DP slaves are switched on or correspond with your configuration, or read out the diagnostic buffer with STEP 7.

Recognizing the operating state of DP slaves (Event recognition)

The table below shows how the DP CPU operating as a DP master recognizes operating mode transitions of a CPU operating as a DP slave or data exchange interruptions.

Table 8- 8 Detecting operating mode transitions and station failure of DP CPUs operated as DP slave in the DP CPU as master

Event	What happens in the DP master?
Bus interruption (short circuit, connector removed)	<ul style="list-style-type: none"> Call of OB 86 with the message Station failure (incoming event; diagnostic address of the DP slave assigned to the DP master) With I/O access: Call of OB 122 (I/O access error)
DP slave: RUN \rightarrow STOP	<ul style="list-style-type: none"> Call of OB 82 with the message Module error (incoming event; diagnostic address of the DP slave assigned to the DP master; variable OB82_MDL_STOP = 1)
DP slave: STOP \rightarrow RUN	<ul style="list-style-type: none"> Call of OB 82 with the message Module OK (incoming event; diagnostic address of the DP slave assigned to the DP master; variable OB 82_MDL_STOP = 0)

Tip:

When commissioning the CPU as DP master, always program OB82 and OB86. This helps you to recognize and evaluate data exchange errors or interruption.

Status/modify, programming via PROFIBUS

As an alternative to the MPI interface, you can program the CPU or execute the PG status and modify functions via the PROFIBUS DP interface.

Note

The use of Status and Modify via the PROFIBUS DP interface extends the DP cycle.

Constant bus cycle time

This is a property of PROFIBUS DP. The "Constant bus cycle time" function ensures that the DP master always starts the DP bus cycle within a constant interval. From the perspective of the slaves, this means that they receive their data from the master at constant time intervals.

In STEP 7 V5.x or higher, you can configure constant bus cycle times for PROFIBUS subnets. Details on constant bus cycle times are found in the *STEP 7 Online Help*.

Isochronous updating of process image partitions

SFC 126 "SYNC_PI" is used for the isochronous update of the process image partition of inputs. An application program which is interconnected with a DP cycle (by means of OB61) can use this SFC for consistent updates of data recorded in the process image partition of inputs in synchronism with this cycle. SFC126 accepts interrupt control and can only be called in OB61.

SFC 127 "SYNC_PO" is used for the isochronous update of the process image partition of outputs. An application program which is interconnected to a DP cycle can use the SFC for the consistent transfer of the computed output data of a process image partition of outputs to the I/O in synchronism with this cycle. SFC 127 accepts interrupt control and can only be called in OB 61.

The SFCs 126 and 127 are described in the *STEP 7 Online Help* and in the *System Software S7-300/400, System and Standard Functions Reference Manual*.

The following CPUs support isochronous mode at the PROFIBUS DP:

- CPU 315-2 DP
- CPU 315-2 PN/DP
- CPU 317-2 DP
- CPU 317-2 PN/DP
- CPU 319-3 PN/DP

CPUs with two DP interfaces (CPU 317-2 DP and CPU 319-3 PN/DP) only support isochronous mode on their second (DP) interface.

Note

Isochronous mode is possible on PROFIBUS or on PROFINET.

Reference

For more information about the isochronous mode, refer to the Isochronous mode (<http://support.automation.siemens.com/WW/view/en/15218045/>) Manual.

Clock synchronization

For information about clock synchronization via PROFIBUS DP, refer to the CPU 31xC und CPU 31x Manual, Technical Specifications, chapter: Clock synchronization.

Sync/Freeze

The SYNC control command is used to set sync mode on the DP slaves of selected groups. In other words, the DP master transfers current output data and instructs the relevant DP slaves to freeze their outputs. The DP slaves writes the output data of the next output frames to an internal buffer; the state of the outputs remains unchanged.

Following each SYNC control command, the DP slaves of the selected groups transfer the output data stored in the internal buffer to the process outputs.

The outputs are only updated cyclically again after you transfer the UNSYNC control command using SFC11 "DPSYC_FR".

The FREEZE control command is used to set the relevant DP slaves to Freeze mode, in other words, the DP master instructs the DP slaves to freeze the current state of the inputs. It then transfers the frozen data to the input area of the CPU.

Following each FREEZE control command, the DP slaves freeze the state of their inputs again.

The DP master receives the current state of the inputs cyclically again only after you have sent the UNFREEZE control command with SFC11 "DPSYC_FR".

The SFC 11 is described in the corresponding *STEP 7 Online Help* and in the *System Software S7-300/400, System and Standard Functions Reference Manual*.

Startup of the DP master system

DP CPUs as DP master
The Parameter transfer to modules parameter is also used to define the startup monitoring time for DP slaves.
That is, the DP slaves must startup and must have received all parameters from the CPU (as DP master) within the defined time.

PROFIBUS address of the DP master

For the DP CPU, you **must not set "126"** as a PROFIBUS address.

8.5.3 Commissioning the CPU as DP Slave

Requirements for commissioning

- The DP master is configured and programmed.
- If the MPI/DP interface of your CPU must be a DP interface, you must configure the interface as DP interface.
- Prior to commissioning, you must set the relevant parameters and configure the DP CPU for operation as DP slave. That is, in STEP 7 you have to
 - "power on" the CPU as DP slave,
 - assign a PROFIBUS address to the CPU,
 - assign a slave diagnostic address to the CPU,
 - specify whether the DP master is an S7 DP master or another DP master,
 - specify the address ranges for data exchange with the DP master.
- All other DP slaves are programmed and configured.

GSD files

If you are working on an IM 308-C or third-party system, you require a GSD file to configure the DP CPU as a DP slave in a DP master system.

COM *PROFIBUS V4.0* or later includes this GSD file.

When working with an older version or another configuration tool, you can download the GSD file from the Internet

(<http://support.automation.siemens.com/WW/view/en/10805317/133100>).

Note

This note applies to the CPUs 31xC-2 DP, CPU 315, CPU 317 and CPU 319.

If you wish to use the CPU as a standard slave using the GSD file, you must not set the Commissioning / Test mode check box on the DP interface properties dialog box when you configure this slave CPU in STEP 7.

Configuration and parameter assignment message frame

STEP 7 assists you during configuration and parameter assignment of the DP CPU. If you need a description of the configuration and parameter assignment frame, for example in order to use a bus monitor, you can find it on the Internet

(<http://support.automation.siemens.com/WW/view/en/1452338>).

Commissioning

Commission the DP CPU as a DP slave in the PROFIBUS subnet as follows:

1. Switch on power, but hold the CPU in STOP mode.
2. First, switch on all other DP masters/slaves.
3. Now switch the CPU to RUN mode.

Startup of DP CPU as DP slave

When the DP-CPU is switched to RUN mode, two mutually independent operating mode transitions are executed:

- The CPU switches from STOP to RUN mode.
- The CPU starts data exchange with the DP master via the **PROFIBUS DP interface**.

Recognizing the Operating State of the DP master (Event Recognition)

The table below shows how the DP CPU operating as a DP slave recognizes operating state transitions or data exchange interruptions.

Table 8- 9 Detecting operating mode transitions and station failure of DP CPUs operated as DP master, in the DP CPU as DP slave

Event	What happens in the DP slave?
Bus interruption (short circuit, connector removed)	<ul style="list-style-type: none"> • Call of OB 86 with the message Station failure (coming event; diagnostic address assigned to the DP slave) • With I/O access: Call of OB 122 (I/O access error)
DP master: RUN → STOP	<ul style="list-style-type: none"> • Call of OB 82 with the message Module error (incoming event; diagnostic address assigned to the DP slave; variable OB82_MDL_STOP = 1)
DP master: STOP → RUN	<ul style="list-style-type: none"> • Call of OB 82 with the message Module OK (outgoing event; diagnostic address assigned to the DP slave; variable OB82_MDL_STOP = 0)

Tip:

When commissioning the CPU as DP slave, always program OB82 and OB86. This helps you to recognize and evaluate the respective operating states or data exchange errors.

Status/modify, programming via PROFIBUS

As an alternative to the MPI interface, you can program the CPU or execute the PG's status and control functions via the PROFIBUS DP interface.

Note

The execution of status and control function via PROFIBUS DP interface extends the DP cycle.

User data transfer by way of transfer memory

The DP CPU operating as intelligent DP slave provides a transfer memory for PROFIBUS DP. User data are always exchanged between the CPU (DP slave) and the DP master by way of this transfer memory. You can configure up to 32 address ranges for this function.

That is, the DP master writes its data to these transfer memory address ranges, the CPU reads these data in the user program, and vice versa.

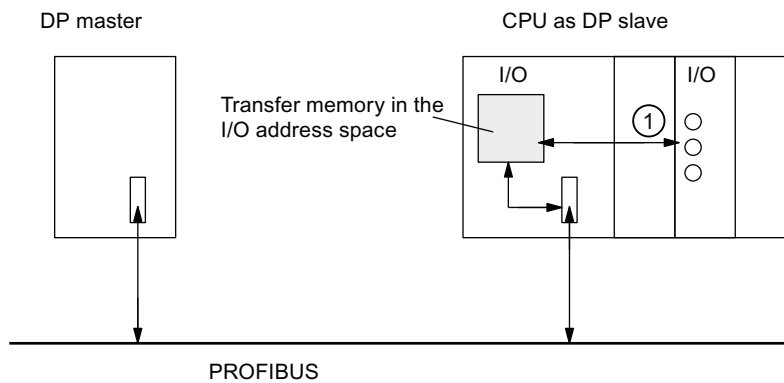

Number	Description
①	The functions which control data exchange between transfer memory and the distributed I/O of the slave CPU must be implemented in the user program. The DP master cannot access this I/O directly.

Address ranges of transfer memory

In STEP 7, configure the I/O address ranges:

- You can configure up to 32 I/O address ranges.
- The maximum length of this address range is 32 bytes.
- You can configure a maximum of 244 input bytes and 244 output bytes.

The table below shows the principle of address ranges. You can also find this figure in the STEP 7 configuration.

Table 8- 10 Configuration example for the address ranges of transfer memory

	Type	Master address	Type	Slave address	Length	Unit	Consistency
1	I	222	O	310	2	BYTE	Unit
2	O	0	I	13	10	Word	Total length
:							
32							
	Address ranges in the DP master CPU		Address ranges in the DP slave CPU		These parameters of the address ranges must be the same for DP master and DP slave.		

Example program

Below, you will see a small example program for data exchange between the DP master and the DP slave. The addresses used in the example are found in the table above.

In the DP slave CPU		In the DP master CPU	
L	2		//Data preparation in the //DP slave
T	MB 6		
L	IB 0		
T	MB 7		
L	MW 6		//Forward data to //DP master
T	PQW 310		
		L	PIB 222 //continued processing of //received data in DP master
		T	MB 50
		L	PIB 223
		L	B#16#3
		+	I
		T	MB 51
		L	10 //Data preparation in the //DP master
		+	3
		T	MB 60
		CAL	SFC 15 //Send data to the DP slave
		L	
			LADDR:= W#16#0
			RECORD:=P#M60.0 //In the user program of the Byte20 masters //a block of 20 bytes length //starting at MB60 //is written consistently to the //output area //PAB0 to PAB19 //(transfer area from master to //slave)
			RET_VAL :=MW 22
CALL	SFC 14		//Receive data from //DP master
	LADDR:=W#16#D		//In the slave, the //peripheral bytes PEB13 //to PEB32 (data //transferred from master) //are read consistently and //stored in MB30

```

//to MB49
RET_VAL :=MW 20
RECORD:=P#M30.0 byte 20
L      MB   30  //Received data
                //continue processing
L      MB   7
+      I
T      MW   100

```

Working with transfer memory

Note the following rules when working with the transfer memory:

- Assignment of address ranges:
 - Input data of DP slaves are **always** output data of the DP master
 - Output data of DP slaves are **always** input data of the DP master
- The user can define these addresses. In the user program, access data with load/transfer instructions or with SFC 14 and SFC 15. You can also define addresses of the process image of inputs or outputs.
- The lowest address of specific address ranges is their respective start address.
- The length, unit and consistency of the address ranges for DP master and DP slave must be identical.
- The master and slave addresses may differ in logically identical transfer memory (independent logical I/O address spaces in the master and slave CPU).

Note

Assign addresses from the I/O address range of the DP CPU to the transfer memory. You cannot use any addresses which have been assigned to transfer memory for other I/O modules.

S5 DP master

If you use an IM 308-C as a DP master and the DP CPU as a DP slave, the following applies to the exchange of consistent data.

Use IM 308-C in the S5 control to program FB192 for enabling exchange of consistent data between the DP master and slave. With the FB192, the data of the DP CPU are only output or read out in a consistent block.

S5-95 as DP master

If you set up an AG S5-95 for operation as DP master, you also have to set its bus parameters for the DP CPU as DP slave.

User data transfer in STOP mode

User data is treated in transfer memory according to the STOP state of the DP master or DP slave.

- **The DP slave CPU goes into STOP:**

Data in transfer memory of the CPU is overwritten with "0", that is, the DP master reads "0" in direct data exchange mode.

- **The DP master goes into STOP:**

Current data in transfer memory of the CPU are retained and can be read by the CPU.

PROFIBUS address

For the DP CPU, you **must not set "126"** as a PROFIBUS address.

See also

User-specific addressing of modules (Page 129)

8.5.4 Direct data exchange

Requirements

STEP 7 V 5.x or higher lets you configure "Direct data exchange" for PROFIBUS nodes. DP CPUs can take part in direct data exchange as senders and receivers.

Definition

"Direct data exchange" is a special communication relationship between PROFIBUS DP nodes.

Characteristic of direct data exchange are the PROFIBUS DP nodes "Listening" on the bus for data a DP slave returns to its DP master. This mechanism allows "Listening stations" (receivers) direct access to modified input data of remote DP slaves.

address ranges

In your STEP 7 configuration of the relevant peripheral input addresses, specify which address range of the receiving node is to receive data requested from the sending node.

The following types of DP-CPU are possible:

- DP slave sending station
- Receiving station, as DP slave or DP master, or as CPU not integrated in a master system.

Example: Direct data exchange via DP CPUs

The example in the figure below shows the relationships you can configure for direct data exchange. In the figure all the DP masters and all the DP slaves that are marked as "CPU" are each a DP CPU.

Note that other DP slaves (ET 200M, ET 200pro, ET 200S) can only operate as sending nodes.

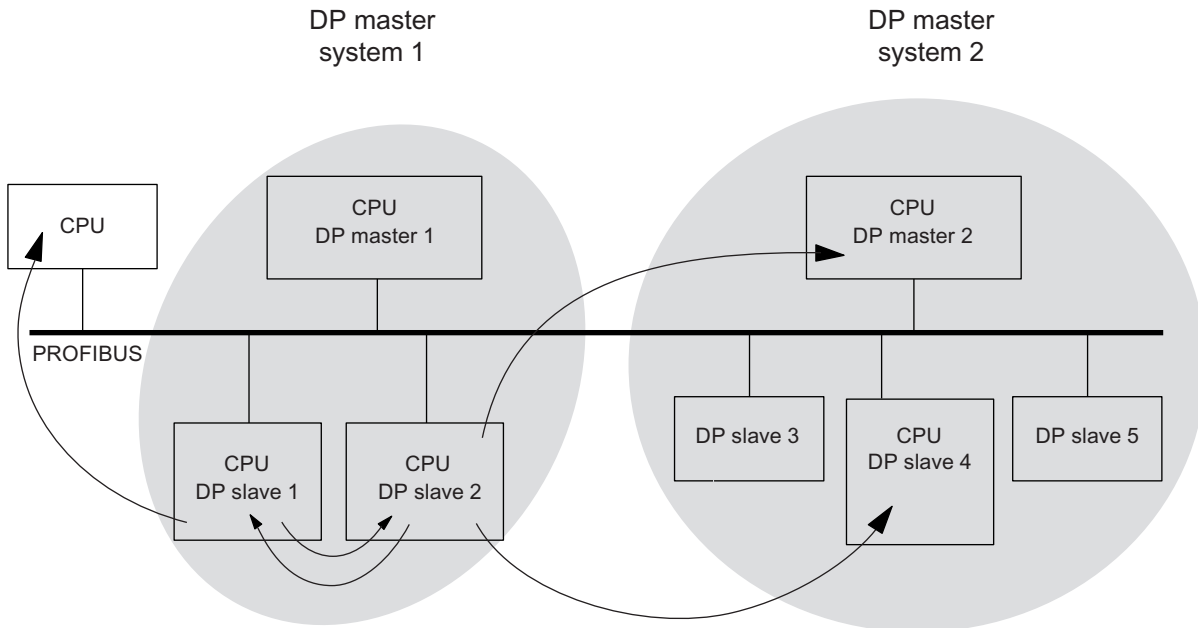

Figure 8-1 Direct data exchange via DP CPUs

8.6 Commissioning PROFINET IO

8.6.1 Requirements

Requirements

PROFINET IO is supported in STEP 7 V5.3 SP1 or higher. A later version of STEP 7 may be required to support specific CPU functionality. Information about the STEP 7 versions required for specific CPUs is available in the *CPU 31xC and CPU 31x, Technical Data Manual*.

PROFINET IO address ranges of the CPUs

Table 8- 11 PROFINET IO address ranges of the CPUs

Address range	314C-2 PN/DP	315-2 PN/DP	317-2 PN/DP	319-3 PN/DP
Entire address range of inputs and of outputs	2048 Bytes	2048 Bytes	8192 Bytes	8192 Bytes
of these in the process image, for inputs and outputs respectively	Max. 2048 bytes	Max. 2048 bytes	Max. 8192 bytes	Max. 8192 bytes
• Default	256 Bytes	128 Bytes	256 Bytes	256 Bytes

Diagnostic addresses use 1 byte each in the input address range for

- the IO controller, PROFINET interface and ports
- all I/O devices (PROFINET interface and its ports) and all modules/submodules inside the device

You can use these addresses, for example, to read module-specific diagnostics data records by calling SFB52. STEP 7 assigns diagnostic addresses in descending order, starting at the highest byte address.

Information about the structure of module-specific diagnostics data records is available in the *From PROFIBUS DP to PROFINET IO Programming Manual*.

8.6.2 Commissioning the PROFINET IO system

Commissioning requirements:

- The CPU is in STOP mode.
- The IO devices are switched on.
- The PROFINET subnet is installed and the communication nodes (e.g. programming device, IO controller, IO devices) are connected to the PROFINET subnet.

Options of commissioning the PROFINET IO system

There are several ways for you to start with commissioning the PROFINET IO interface of the CPU, and then the PROFINET IO system:

- Online via MPI/ DP interface
- online via the PROFINET interface
- Offline, by saving the data to a Micro Memory Card in SIMATIC Manager on your programming device and then inserting the Micro Memory Card into the CPU

Commissioning a PROFINET IO system via MPI/DP

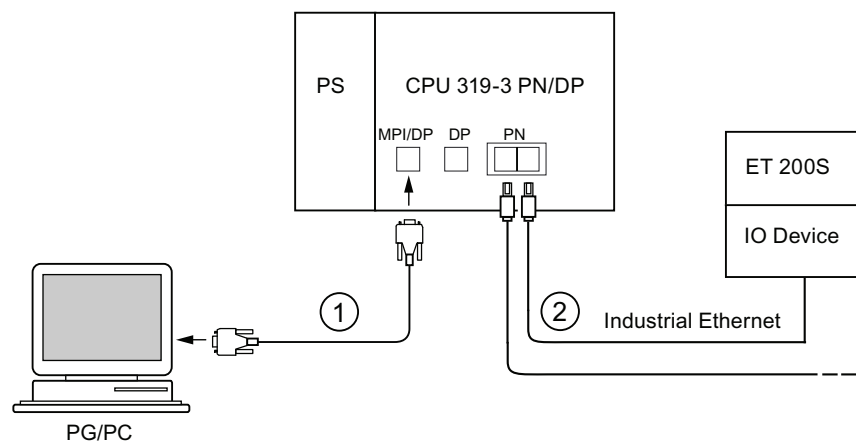

Number	Meaning
①	Use the PG cable to connect the PG to the integrated MPI/DP interface of the CPU.
②	Using a twisted-pair cable, connect the IO device to a port of the PROFINET interface of the CPU. You can connect additional PROFINET devices to the second free port of the PROFINET interface.

Note

Usually, you must use an external switch to interconnect CPUs 31x PN/DP without integrated switch (PN interface with single port) with other PROFINET devices.

Commissioning a PROFINET IO system directly via PROFINET interface

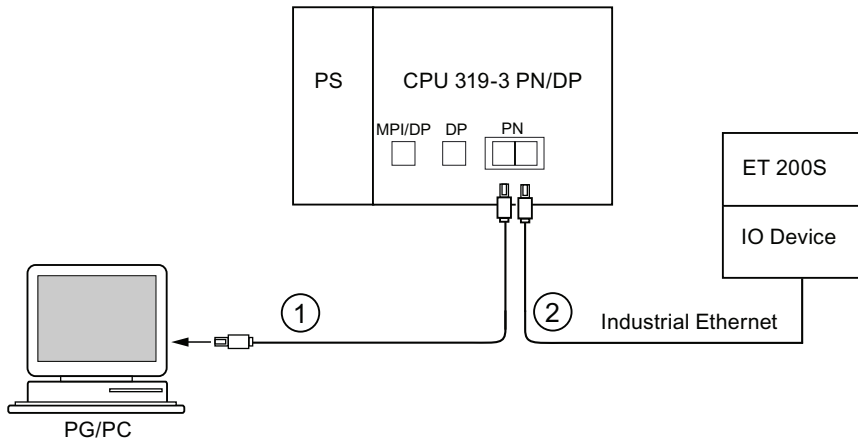

- | Number | Meaning |
|--------|--|
| ① | Using a preassembled twisted-pair cable, connect the programming device/PC to one of the ports of the PROFINET interface of the CPU. |
| ② | Using a twisted-pair cable, connect the IO device to the second available port of the PROFINET interface of the CPU. |

8.6.3 Configuring the PROFINET IO system

Configuring the PROFINET IO system

Step	Tasks
Configuring hardware in the STEP 7 SIMATIC Manager	
1	Select File > New ... Assign a name to your project and confirm with "OK".
2	Select Insert > Station > SIMATIC 300 Station to add an S7-300 station.
3	Double-click "Hardware". Result: HW Config opens.
4	Insert your components by means of drag-and-drop: <ul style="list-style-type: none"> • Mounting rail • Power supply • CPU 31x PN/DP (CPU 317-2 PN/DP, for example) Result: The "Properties – Ethernet Interface PN-IO" dialog box opens. The properties of the PROFINET X2 interface are shown in the Parameters tab.
Assigning the IP address (example: assigning a retentive IP address)	
5	Click "New" on the "Properties – Ethernet Interface PN-IO" dialog box to create a new subnet. Result: The "Properties – New Industrial Ethernet Subnet" dialog box opens.

Step	Tasks
6	Assign a name and confirm with "OK". Result: You are back to the "Properties – Ethernet Interface PN-IO" dialog box.
7	Enter the IP address and the subnet mask in the dialog box. This information is available from your network administrator. Note: The worldwide unique MAC address is preset by the manufacturer and cannot be changed.
8	If you setup a connection via router, you must also enter the address of the router. This information is also available from your network administrator.
9	Click "OK" to close the properties dialog box.
Configuring the PROFINET IO system	
10	Insert the IO devices at the PROFINET IO system, for example, an IM 151-3 PN (ET 200S under PROFINET IO), then configure the slots and set their parameters by means of drag-and-drop, based on the physical assembly.
11	Select Edit > Object properties to assign device names and numbers to the IO devices.
12	When operating PROFINET IO and PROFINET CBA in parallel, set up the PROFINET IO system properties by <ul style="list-style-type: none"> • activating the "Use this module for PROFINET CBA communication" check box • adapting the "Communication portion (PROFINET IO)" in the "Update time" tab (change the communication portion of PROFINET IO to 87.5 %, for example). <div style="border: 1px solid black; padding: 5px; margin-top: 10px;"> <p>Properties - PN-IO-1 (R0/S2.2)</p> <p>General Addresses PROFINET Synchronization Time-of-Day Synchronization</p> <p>Send clock: 1.000 ms</p> <p>IO communication</p> <p>Communication allocation (PROFINET IO): 87.5 %</p> <p>Max. IRT stations in line: 0</p> <p><input checked="" type="checkbox"/> Use system settings</p> <p>CBA communication</p> <p><input checked="" type="checkbox"/> Use this module for PROFINET CBA communication</p> <p>Communication allocation (PROFINET CBA): 12.5 %</p> <p>Possible QoS with cyclic interconnections: 10 - 1000 ms</p> <p><input type="checkbox"/> OB 82 / I/O fault task - call at communications interrupt</p> <p>OK Cancel Help</p> </div>
13	If you want the diagnostic events reported to the PROFINET interface to trigger the call of a diagnostic interrupt OB (OB 82), open the properties dialog of the PROFINET IO system <ul style="list-style-type: none"> • and select the check box "OB 82 / IO fault task - call at communications interrupt" Tip: The event information is also available in the diagnostic buffer of the CPU.
14	Save your configuration with Station > Save and compile .

Step	Tasks
Configuration Download	
15	<p>Download the configuration to the CPU. You have three options:</p> <ul style="list-style-type: none"> • Online via MPI/ DP interface (the PG and CPU must be located in the same subnet). When you download the configuration in a system containing several node addresses, select the appropriate MPI or PROFIBUS address of the destination CPU. • online via the PROFINET interface When you download the configuration in a system containing several nodes, select the appropriate IP address of the destination CPU. The "available users" can be displayed in a download dialog box. If you have not yet assigned an IP address to the CPU, select the MAC address of the target CPU. In the next dialog box, you can assign the configured IP address to the CPU. <p>The PG must be connected to the subnet. The interface of the programming device must be set to TCP/IP (Auto) mode. Setting in the IE-PG Access tab of the interface properties dialog box: Assign project-specific IP address.</p> <ul style="list-style-type: none"> • Offline, by saving the data to a Micro Memory Card in SIMATIC Manager on your programming device and then inserting the Micro Memory Card into the CPU
Assigning IO device names	
16	<p>Requirement: The programming device must be connected to the subnet. The interface of the programming device must be set to TCP/IP (Auto) mode. Setting in the IE-PG Access tab of the interface properties dialog box: Assign Project-Specific IP Address.</p> <p>Procedure: In online mode, select the various IO devices in HW Config, then select PLC > Ethernet > Assign Device Name to assign the corresponding device names.</p> <p>Note: If you enabled the "Support device replacement without removable medium" function in your parameters and specified the target topology of the PROFINET IO system using the topology editor, you could possibly dispense with the specification of the device name. For this to be the case, the actual topology must correspond with the target topology and the devices must be reset to the factory settings.</p> <p>Note: The CPU can only assign the IP address automatically, and thus enable its correct communication with the IO device, after you assigned a device name to the latter.</p> <p>If the configuration of the IO devices you downloaded to the CPU actually corresponds with their physical configuration on the subnet, the CPU addresses the IO devices, and the BF LED stops flashing both on the CPU and on the IO device.</p> <p>You can now switch the CPU to RUN, provided there are no other conditions preventing a startup, and the CPU and IO devices exchange data (read inputs, write outputs, for example).</p>

Result

You used STEP 7 to configure the PROFINET interface of your CPU and the and the PROFINET IO system. The CPU can now be reached by other nodes in your Industrial Ethernet subnet.

Reference

- Additional options for the IP address assignment are described in chapter Assigning IP address parameters and device names (Page 137)
- For more information with regard to the address assignment and settings of the properties for the PROFINET IO interface and the individual ports, refer to the STEP 7 Online Help and to the PROFINET System Description (<http://support.automation.siemens.com/WWW/view/en/19292127>).

CPU startup for operation as IO controller

In its startup sequence, and based on the preset configuration, the CPU verifies the actual configuration

- of the local I/O,
- of the distributed I/O on the PROFIBUS DP system, and
- the PROFINET IO system.

The startup of the CPU is determined by the corresponding configuration in the "Startup" tab:

Table 8- 12 CPU startup for operation as IO controller

Preset configuration = actual configuration	Preset ≠ Actual configuration	
	Startup permitted if the preset configuration does not match the actual configuration	Startup not permitted if the preset configuration does not match the actual configuration
CPU goes into RUN.	CPU goes into RUN. After POWER ON, and after the parameter monitoring time has expired, the CPU goes into RUN. The flashing of the BF-LED for the PROFINET interface indicates that at least one IO device cannot be addressed. In this case, check whether all IO devices are switched on and correspond to the specified configuration. For additional information, read the diagnostics buffer in STEP 7.	CPU startup fails.

CPU startup for operation as intelligent device

In its startup sequence, and based on its preset configuration, the CPU verifies the actual configuration

- of the local I/O,
- of the distributed I/O on the PROFIBUS DP system, and
- the PROFINET IO system.

The CPU startup depends on the CPU configuration in the **Startup** tab:

Table 8- 13 CPU startup for operation as intelligent device

Target configuration = actual configuration	Preset configuration ≠ actual configuration	
	Startup permitted if the preset configuration does not match the actual configuration	Startup not permitted if the preset configuration does not match the actual configuration
CPU goes into RUN.	<p>CPU goes into RUN. The CPU goes into RUN after POWER ON and expiration of the parameter monitoring time. Flashing of the BF-LED for the PROFINET interface means that:</p> <ul style="list-style-type: none"> • In a configuration as I-device without IO subsystem: None of the higher-level controllers is able to communicate with the I-device (for example, a connection interruption or mismatch of the transfer areas between the IO controller and the I-device). In this situation, check the configuration and wiring of the PROFINET IO system. • In a configuration as I-device with IO subsystem: The higher-level controller is unable to communicate with the I-device (for example, a connection interruption or mismatch of the transfer areas between the IO controller and the I-device). <p>Or: At least one IO device cannot be addressed. In this case, check whether all IO devices are switched on and correspond to the specified configuration.</p> <p>For more information, read the diagnostics buffer in <i>STEP 7</i>.</p>	CPU startup fails.

Detecting interruptions in the data transfer to the IO device

The following table shows, how the CPU 31x PN/DP recognizes interruptions of the data transfer:

Table 8- 14 Even recognition of the CPU 31x PN/DP as IO controller

Event	What happens in the IO controller?	
	CPU in RUN	CPU in STOP
Bus interruption (short circuit, connector removed)	<ul style="list-style-type: none"> • Call of OB86 with the message Station failure (coming event; diagnostics address of the IO device) • With I/O access: Call of OB 122 (I/O access error) 	<ul style="list-style-type: none"> • The event is written to the diagnostics buffer

For additional information about this topic and the response to operating mode transitions in the IO controller or I-device, refer to chapter "Intelligent Device" in the PROFINET System Description.

Note

When commissioning the CPU for operation with intelligent devices, always program the OB 83 in the IO controller and intelligent device (because of the return-of-submodule alarms generated during the operating state transition to RUN of the relevant communication partner).

Always program OB86 when you commission the CPU. This allows you to detect and analyze interruptions in the data transfer.

If "OB85 - call up at I/O access error" was configured in HW Config to detect access errors during transfer of the process image, OB85 must also be programmed.

Reference

More detailed information about the user data transfer is found in the PROFINET System Description (<http://support.automation.siemens.com/WW/view/en/19292127>).

Status/control, programming via PROFINET

As an alternative to the MPI /DP interface, you can program the CPU or execute the PG's status and control functions via the PROFINET interface..

If you have not commissioned the PROFINET interface of the CPU yet, you can connect to the CPU using its MAC address (see also **Configuring the PROFINET IO System** in the table above).

To do so, use HW Config to download your configuration to the CPU. Address the CPU using its MAC address. The CPU is also assigned the configured IP address after you downloaded the configuration. You can now use all PG functions on the interface, for example, loading the program, monitor/modify,

Maintenance

9.1 Overview

Maintenance in terms of the S7-300

- refers to the backup of the operating system to a SIMATIC Micro Memory Card
- Updating of the operating system from a SIMATIC Micro Memory Card
- Updating of the firmware online
- Backing up of project data on a SIMATIC Micro Memory Card
- Replacement of modules
- Replacement of fuses in digital output modules

9.2 Backing up firmware on a SIMATIC Micro Memory Card

Situations which require backup of the firmware

It is advisable in certain situation to backup your CPU firmware:

You may want to replace the CPU in your system with a CPU out of storage. In this case you should make sure that the firmware of the shelf CPU and of the system firmware are identical.

It is also advisable to create an emergency backup copy of the firmware.

On which CPUs can you back up the firmware?

Backup of the firmware is possible as of the following CPU versions:

CPU	Order number	Firmware as of	Required Micro Memory Card ≥ in MByte
312	as of 6ES7312-1AD10-0AB0	V2.0.0	2
	as of 6ES7312-1AE13-0AB0	V2.0.12	
	as of 6ES7312-1AE14-0AB0	V3.0	
312C	as of 6ES7312-5BD00-0AB0	V1.0.0	2
	as of 6ES7312-5BE03-0AB0	V2.0.12	
	as of 6ES7312-5BF04-0AB0	V3.3.1	
313C	as of 6ES7313-5BE00-0AB0	V1.0.0	2
	as of 6ES7313-5BF03-0AB0	V2.0.12	
	as of 6ES7313-5BG04-0AB0	V3.3.1	

9.2 Backing up firmware on a SIMATIC Micro Memory Card

CPU	Order number	Firmware as of	Required Micro Memory Card ≥ in MByte
313C-2 PtP	as of 6ES7313-6BE00-0AB0	V1.0.0	2
	as of 6ES7313-6BF03-0AB0	V2.0.12	
	as of 6ES7313-6BG04-0AB0	V3.3.1	
313C-2 DP	as of 6ES7313-6CE00-0AB0	V1.0.0	4
	as of 6ES7313-6CF03-0AB0	V2.0.12	
	as of 6ES7313-6CG04-0AB0	V3.3.1	
314	as of 6ES7314-1AF10-0AB0	V2.0.0	2
	as of 6ES7314-1AG13-0AB0	V2.0.12	
	as of 6ES7314-1AG14-0AB0	V3.0	
314C-2 PtP	as of 6ES7314-6BF00-0AB0	V1.0.0	2
	as of 6ES7314-6BG03-0AB0	V2.0.12	
	as of 6ES7314-6BH04-0AB0	V3.3.1	
314C-2 DP	as of 6ES7314-6CF00-0AB0	V1.0.0	4
	as of 6ES7314-6CG03-0AB0	V2.0.12	
	as of 6ES7314-6CH04-0AB0	V3.3.1	
314C-2 PN/DP	as of 6ES7314-6EH04-0AB0	V3.3	8
315-2 DP	as of 6ES7315-2AG10-0AB0	V2.0.0	4
	as of 6ES7315-2AH14-0AB0	V3.0	
315-2 PN/DP	as of 6ES7315-2EG10-0AB0	V2.3.0	4
	as of 6ES7315-2EH14-0AB0	V3.1	8
317-2 DP	as of 6ES7317-2AJ10-0AB0	V2.1.0	4
	as of 6ES7317-2AK14-0AB0	V3.3.1	
317-2 PN/DP	as of 6ES7317-2EJ10-0AB0	V2.2.0	4
	as of 6ES7317-2EK14-0AB0	V3.1	8
319-3 PN/DP	as of 6ES7318-3EL00-0AB0	V2.4.0	8
	as of 6ES7318-3EL01-0AB0	V3.2	8

This is how you back up the firmware of your CPU to the SIMATIC Micro Memory Card

Table 9- 1 Backing up the firmware to the SIMATIC Micro Memory Card

Step	Action required:	This happens in the CPU:
1	Insert the new SIMATIC Micro Memory Card into the CPU.	The CPU requests a memory reset.
2	Keep the mode selector in the MRES position.	-
3	POWER OFF/POWER ON and keep the mode selector in the MRES position until the STOP, RUN and FRCE LEDs start flashing.
4	Mode selector in STOP position.	-
5	Switch mode selector briefly to MRES position, then let it return to STOP.	<ul style="list-style-type: none"> • The CPU starts to back up the operating system on the SIMATIC Micro Memory Card. • All LEDs are lit during the backup operation. • The STOP LED flashes when the backup is complete to indicate that the CPU requires a memory reset.
6	Remove the SIMATIC Micro Memory Card.	-

9.3 Updating the firmware

Note

Communication shutdown during firmware updates on PROFINET CPUs with integrated switch

Note that the PROFINET interface and the integrated switch are shut down when you update the firmware on this CPU.

During the firmware update on a CPU operated in a line structure, communication via the CPU's integrated switch to downstream devices is shut down.

9.3.1 Firmware update using a Micro Memory Card

In which situations should I update the firmware?

After (compatible) function expansions, or after an enhancement of operating system performance, the firmware of the CPU should be upgraded (updated) to the latest version.

Where do I get the latest version of the firmware?

You can obtain the latest Firmware is available as *.UPD files from your Siemens contact partner, or download it from the Internet at the Siemens Homepage (<http://www.siemens.com/automation/service&support>)

Firmware update using a SIMATIC Micro Memory Card

Table 9- 2 Firmware update using a SIMATIC Micro Memory Card

Step	Action required:	This happens in the CPU:
1	Recommendation Before you update the CPU firmware, create a backup copy of the "old" firmware on an empty SIMATIC Micro Memory Card. If problems occur during the update, you can reload your old firmware from the SIMATIC Micro Memory Card.	
2	Transfer the update files to a blank SIMATIC Micro Memory Card using STEP 7 and your programming device.	-
3	Switch off CPU power and insert a SIMATIC Micro Memory Card containing the firmware update.	-
4	Switch on power.	<ul style="list-style-type: none"> • The CPU automatically detects the SIMATIC Micro Memory Card with the firmware update and runs the update. • All LEDs are lit during firmware update. • The STOP LED flashes when the FW update is completed, and indicates that the CPU requires a memory reset.
5	Switch off CPU power and remove a SIMATIC Micro Memory Card containing the firmware update.	-

Result

You updated the CPU with a new firmware version.

The address and baud rate of the first interface remain retentive. All other parameters were reset during the firmware update.

NOTICE

Any cancellation of the firmware update caused by actions such as POWER OFF/ON or removal of the Micro Memory Card can lead to the loss of the CPU firmware. In this mode, only the SF-LED flashes at a frequency of 2 Hz, while all other LEDs are switched off. However, since the boot block is retained, you can restore the valid firmware by repeating the FW update as described above.

9.3.2 Updating the firmware online (via networks)

On which CPUs can you update the firmware online?

You can carry out a firmware update online for all CPUs as of V 2.2 and higher.

Information about the firmware update online using MPI or DP networks for older modules is available on the Service&Support pages (<http://www.siemens.com/automation/service>).

Requirements

- An online firmware update is possible in STEP 7 V 5.3 or higher.
- To update the firmware, you require the *.UPD files which contain the current firmware version.
- The files (*.UPD) containing the current firmware version must be available in the file system on your PG/PC. A folder may contain only the files of one firmware version.
- The CPU can be accessed online.

Performing a firmware update

1. Run STEP 7 and change to HW Config.
2. Open the station containing the CPU you want to update.
3. Select the CPU.
4. Select the menu command **PLC > Update Firmware**. The menu command can only be executed if the selected CPU supports the "Update Firmware" function.
5. The **Update firmware** dialog box opens. Click **Browse** to select the path to the firmware update files (*.UPD)
6. After you selected a file, the information in the lower fields of the **Update Firmware** dialog box shows you the firmware file and version for the corresponding modules.
7. Click the **Run** button. STEP 7 verifies that the selected file can be interpreted by the module, and then downloads the file to the CPU. If this requires changing the operating state of the CPU, you will be asked to perform these tasks in the relevant dialog boxes. The CPU then automatically updates the firmware.
8. In STEP 7 (reading the CPU diagnostics buffer), verify that the CPU can start with the new firmware.

Result

You have updated the CPU online with a new firmware version.

The address and baud rate of the first interface remain retentive. All other parameters were reset during the firmware update.

9.4 Backup of project data to a Micro Memory Card

Function principles

Using the **Save project to Micro Memory Card** and **Retrieve project from Micro Memory Card** functions, you can save all project data to a SIMATIC Micro Memory Card, and retrieve these at a later time. The SIMATIC Micro Memory Card can be located in a CPU or in the Micro Memory Card programming adapter of a PG or PC.

Project data is compressed before it is saved to a SIMATIC Micro Memory Card, and uncompressed on retrieval.

Note

In addition to project data, you may also have to save your user data to the SIMATIC MMC. Always select a SIMATIC Micro Memory Card with sufficient memory capacity.

A message warns you of insufficient memory capacity on your SIMATIC Micro Memory Card.

The volume of project data to be saved corresponds with the size of the project's archive file.

Note

For technical reasons, you can only transfer the entire contents (user program and project data) using the **Save project to Micro Memory Card** action.

Handling the functions

How you use the **Save project to memory card** / **Retrieve project from memory card** functions depends on the location of the SIMATIC micro memory card:

- When the SIMATIC MMC is inserted in the MMC slot, select a project level (for example, CPU, programs, sources or blocks) which is uniquely assigned to the CPU from the project window in SIMATIC Manager. Select the **PLC > Save project to Memory Card** or **PLC > Retrieve project from Memory Card** menu command. The program now writes all configuration data to the SIMATIC Micro Memory Card, or retrieves these data from the card.
- If project data are not available on the currently used programming device (PG/PC), you can select the source CPU from the "Accessible nodes" window. Select **PLC > Display accessible nodes** command to open the "Accessible nodes" window. Select the connection/CPU that contains your project data on SIMATIC Micro Memory Card. Now select menu command **Retrieve project from Memory Card**.
- If the SIMATIC MMC is located in the MMC programming unit of a PG or PC, open the "S7 memory card window" using the **File > S7 Memory Card > Open** command. Select the **PLC > Save project to Memory Card** or **PLC > Retrieve project from Memory Card** menu command. to open a dialog in which you can select the source or target project.

Note

Project data can generate high data traffic. Especially in RUN mode with read/write access to the CPU, this can lead to waiting periods of several minutes.

Sample application

When you assign more than one member of your service and maintenance department to perform maintenance tasks on a SIMATIC PLC, it may prove difficult to provide quick access to current configuration data to each staff member.

However, CPU configuration data available locally on any CPU that is to be serviced can be accessed by any member of the service department. They can edit these data and then release the updated version to all other personnel.

9.5 Resetting to the Delivery State

Delivery state of the CPU

Default values set at the CPU properties:

Table 9- 3 Properties of the CPU in the delivery state

Properties	Value
MPI address	2
MPI baud rate	187,5 kbit/s
Retentive bit memories, timers and counters	All retentive bit memories, timers and counters are deleted
Retentive range set for bit memories, timers and counters	Default setting (16 memory bytes, no timers, and 8 counters)
Contents of the diagnostics buffer	deleted
IP address	Not available
Device name	Not available
Operating hours counter	0
Time	01.01.1994 00:00:00

Procedure

Proceed as follows in order to reset a CPU to the delivery state via the mode selector switch:

1. Switch off the supply voltage.
2. Remove the SIMATIC Micro Memory Card from the CPU.
3. Hold the mode selector switch in the MRES setting and switch the supply voltage on again.
4. Wait until LED lamp image 1 from the subsequent overview is displayed.
5. Release the mode selector switch, set it back to MRES within 3 seconds and hold it in this position.
6. Wait until LED lamp image 2 from the next overview is displayed.
This lamp image lights up for approximately five seconds, that is for the duration of RESET. During this period you can abort the resetting procedure by releasing the mode selector switch.
7. Wait until LED lamp image 3 from the subsequent overview is displayed and release the mode selector switch again.

The CPU is now reset to the delivery state. It starts without buffering (all LEDs are lit) and changes to the STOP mode.

Lamp images while the CPU is being reset

While you are resetting the CPU to the delivery state, the LEDs light up consecutively in the following lamp images:

Table 9- 4 Lamp images

LED	Color	Lamp image 1	Lamp image 2	Lamp image 3
STOP	Yellow	○	□	□
RUN	Green	○	□	□
FRCE	Yellow	○	□	□
5 VDC	Green	△	△	△
SF	Red	□	○	△
BFX	Red	□	□	□
△ = LED is lit □ = LED is dark ○ = LED flashes at 0.5 Hz				

Note

When removing a PROFINET CPU for use at a different location, or when putting it on shelf, always restore the CPU to factory settings since its IP address and device name are usually stored in retentive memory.

9.6 Module installation/removal

Installation and wiring rules

The table below shows you points to follow when wiring, installing or removing S7-300 modules.

Rules governing	... Power supply	... CPU	... SM/FM/CP
Blade width of the screwdriver	3.5 mm (cylindrical design)		
Tightening torque			
• Fixing modules to the mounting rail	from 0.8 Nm to 1.1 Nm		from 0.8 Nm to 1.1 Nm
• Connecting cables	from 0.5 Nm to 0.8 Nm		–
POWER OFF when replacing the ...	Yes		Yes
S7-300 operating mode when replacing ...	–		STOP
Load voltage OFF when replacing the ...	Yes		Yes

Initial situation

The module you want to replace is still mounted and wired. You want to install the same type of module.

WARNING

Disturbances can corrupt data if you insert or remove S7-300 modules while data are being transferred via the integrated interface of your CPU. You should never replace any modules of the S7-300 while data traffic is active at an integrated interface. If you are not certain whether or not data transfer is active on the interface, unplug the connector at the interface before you replace the module.

Removing the module (SM/FM/CP)

To remove the module:

Step	20-pin front connector	40-pin front connector
1	Switch the CPU to STOP.	
2	Switch off the load voltage to the module.	
3	Remove the labeling strip from the module.	
4	Open the front door.	
5	Unlock the front connector and remove it. To do so, press down the unlocking mechanism with one hand and pull out the front connector at the grips using the other hand.	Remove the fixing screw from the middle of the front connector. Pull the front connector out, holding it at the grips.
6	Undo the module fixing screw(s).	
7	Swing the module out.	

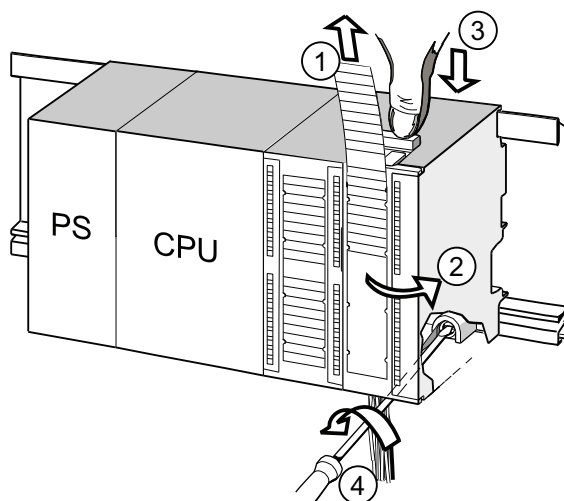

Number Description

- ① Remove labeling strips.
- ② Open module.
- ③ Press unlocking mechanism/loosen mounting screw and pull out front connector.
- ④ Remove mounting screw of module and swing module out.

Removing the front connector coding from the module

Remove the top part of the front connector coding from the new module to be installed.

Reason: This part is already inserted in the wired front connector.

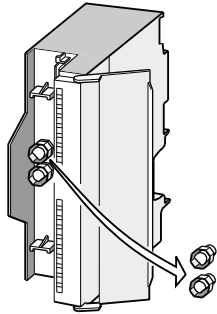

Installing a new module

To install the new module:

1. Hang in a new module of same type.
2. Swivel the module down into place.
3. Screw-tighten the module.
4. Slide the labeling strips into the module.

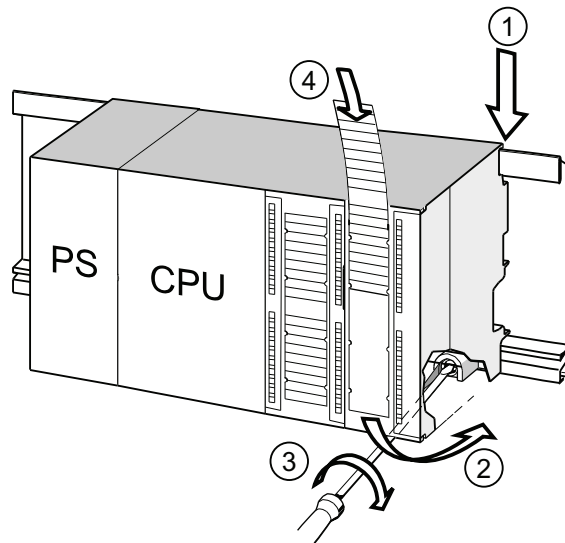

Number	Description
①	Hang module onto rail
②	Swivel module downward
③	Screw-tighten the module
④	Insert labeling strips

Removing the front connector coding from the front connector

To rewire a "used" front connector for a different module, remove the front connector coding from the front connector:

Simply push the front connector coding out of the front connector using a screwdriver.

Reinsert the top part of the front connector coding into the front connector coding of the old module.

Putting a new module into service

Proceed as follows to put the new module into service:

1. Open the front door.
2. Reinstall the front connector.
3. Close the front panel.
4. Switch the load voltage back on.
5. Reset the CPU to RUN mode.

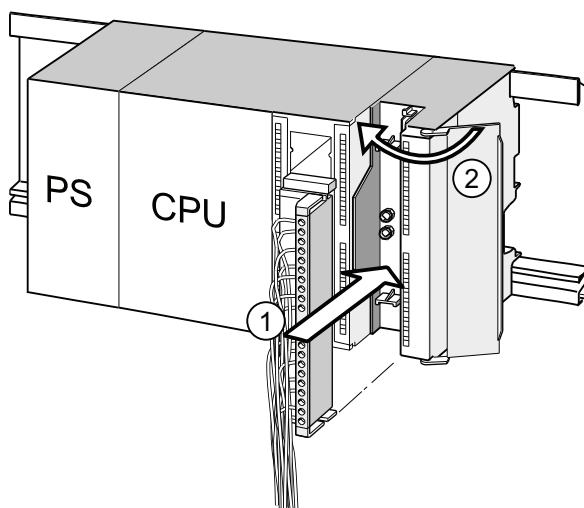

Number	Description
①	Move the front connector into operating position
②	Close front panel

Reaction of the S7-300 after module replacement

After a module replacement, the CPU switches to run mode, provided no error has occurred. If the CPU stays in STOP mode, you can view the cause of error in STEP 7 (see the *Programming with STEP 7* user manual).

9.7 Digital output module: Changing fuses

Fuses for digital outputs

The digital outputs of the following digital output modules are short-circuit protected by fusing of the channel groups:

- Digital output module SM 322; DO 16 x AC 120 V
- Digital output module SM 322; DO 8 x AC 120/230 V

System check

Eliminate the causes of fuse tripping.

Replacement fuses

If replacement is required, you can use the following fuses:

- 8 A, 250 V fuse
 - Wickmann 19 194-8 A
 - Schurter SP001.013
 - Littlefuse 217.008
- Fuse holder
 - Wickmann 19 653

WARNING

Injuries or damages can result from improper handling of the digital modules. There are dangerous voltages > 25 VAC or > 60 VDC beneath the covers to the right of the module. Before you open these covers, make sure that you have either unplugged the front connector from the module or isolated the module from power.

WARNING

Injuries or damages can result from improper handling of front connectors. Dangerous voltages > 25 VAC or > 60 VDC may be present at the pins when you pull or insert the front connector during operation. If such voltages are present at the front connector, only qualified electricians or personnel instructed by such specialists may replace live modules, in such a way that they avoid touching the module pins in the process.

Location of the fuses on the digital output module

Digital output modules are equipped with 1 fuse per channel group. The fuses are located at the left side of the digital output module. The following figure shows you where to find the fuses on the digital output modules.

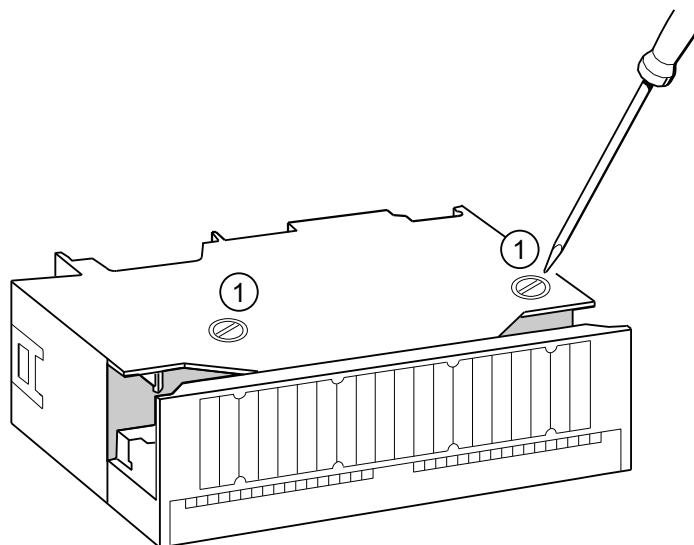

Replacing fuses

The fuses are located at the left side of the module. Replace the fuses as follows:

1. Switch the CPU to STOP.
2. Switch off the load voltage of the digital output module.
3. Remove the front connector from the digital output module.
4. Loosen the fixing screw of the digital output module.
5. Swing out the digital output module.
6. Remove the fuse holder from the digital output module ①.
7. Replace the fuse.
8. Screw the fuse holder back into the digital output module.
9. Reinstall the digital output module.

10.1 Overview

This chapter helps you to get acquainted with tools you can use to carry out the following tasks:

- Hardware/software error diagnostics.
- Elimination of hardware/software errors.
- Testing the hardware/software – for example, during commissioning.

Note

It would go beyond the scope of this manual to provide detailed descriptions of all the tools you can use for diagnostics, testing and troubleshooting functions. Additional notes are found in the relevant hardware/software manuals.

10.2 Reading out service data

Application (for CPUs \geq V2.8)

In the case of a service, for example if the CPU signals the state "DEFECTIVE" (all LEDs blinking), you have the option of saving special information for analyzing the CPU state.

This information is stored in the diagnostic buffer and in the actual service data.

Select the "Target system -> Save service data" command to read and this information and save the data to a file to forward to Customer Support.

Procedure

1. If the CPU is in the state "DEFECTIVE" (all LEDs blinking), switch the power supply off and on (power off/on).
Result: The CPU is now in STOP mode.
2. As soon as the CPU goes to "STOP" mode, select the corresponding CPU with the menu command in the SIMATIC Manager: Target system > Available nodes".
3. Use the SIMATIC Manager menu command "Target system > Save service data" to save the service data.
Result: A dialog box opens in which you specify the storage location and name of the two files.
4. Save the file.
5. Forward these files to Customer Support on request.

10.3 Identification and maintenance data of the CPU

Definition and properties

Identification and maintenance data (I&M) is information that is stored in a module for the purpose of providing you with support when:

- checking the system configuration
- locating modified plant hardware
- troubleshooting a plant

Identification data (I data) is information about the module (some of which may be printed on the module housing) such as the order and serial number.

I data is manufacturer's information about the module. It is fixed and can only be read.

Maintenance data (M data) represent system-specific information such as the installation location. M data is created during configuration and written to the module.

I&M data can be used to identify modules uniquely on the network.

Reading and writing I&M data with STEP 7

Read

- *STEP 7* returns I&M data in "Module status" ("General" and Identification" tab) and in "Accessible nodes" (detail view). See the STEP 7 Online Help.
- You can read I&M data by calling SFC51 in the user program. Declare the SSL parts list number and index at the input parameters of SFC51 (see the table below).
- CPUs which support reading of I&M data on the "Start page" and "Identification" page using the web server:

CPU	Firmware
CPU 314C-2 PN/DP	as of V3.3
CPU 315-2 PN/DP	as of V2.5
CPU 317-2 PN/DP	as of V2.5
CPU 319-3 PN/DP	as of V2.5

Write

You always require *STEP 7* HW Config to write M data of the modules.

Data you can enter in the course of configuration , for example:

- Name of the AS (station name)

The station name is assigned in SIMATIC Manager when you create the station. The program generates a default station, for example, "SIMATIC 300(1)". You can always change this name.
- Data you can enter in STEP 7 HW Config, "CPU properties", "General" tab:
 - Name of the module
HW Config assigns a default name
 - Plant ID of the module
No default setting
 - Location identifier (LID) of a module
No default setting

Reading the I&M data in the user program

In order to read I&M data of the CPU in the user program, define the SSL ID and index and read the corresponding SSL by calling SFC51. The table below shows the SSL IDs and associated indexes.

SSL partial lists with I&M data

The I&M data are available in the SSL partial lists at the defined indexes.

Table 10- 1 SSL partial lists with I&M data

SSL-ID W#16#...	Index W#16# ...	Meaning
Module identification		
0111		an identification data record
	0001	Identification of the module The module order number and release version are stored here.
	0006	Identification of the basic software Returns information about the SW version of the module. (These identification data are identical to index 0001, as a basic software is not available for S7-300 CPUs.)
	0007	Identification of the basic firmware Indicates the firmware version of the module.

SSL-ID W#16#...	Index W#16# ...	Meaning
Component identification		
011C		Component identification
	0001	Name of the AS Returns the name of the AS (station name).
	0002	Name of the module Returns the name of the module.
	0003	Plant ID of the module Returns a unique identifier for the module.
	000B	Location identifier (LID) of a module Returns the installation location of the module.

Reference

For detailed information about the structure and content of the SSLs, refer to the *System Software for S7-300/400, System and Standard Functions Manual* and to the *STEP 7 Online Help*.

I&M data of connected I/O

Information about the I&M data of I/O connected to the CPU is available in the manuals of the corresponding I/O modules.

10.4 Overview: Debugging functions

Determining addressed nodes with "Node flashing test" (for CPUs >= V2.2.0)

To identify the addressed node, select PLC > Diagnostics/Setting > Node/Flashing Test in STEP 7.

A dialog appears in which you can set the flashing time and start the flashing test. The directly connected node can be identified by a flashing FORCE LED. The flashing test cannot be performed if the FORCING function is active.

Debugging functions of the software: Monitoring and modifying variables, stepping mode

STEP 7 offers you the following testing functions you can also use for diagnostics:

- Monitoring and modifying variables

Can be used for PG/PC monitoring of specific CPU or user program variables. You can also assign constant values to the variables.

- Testing with program status

You can test your program by viewing the program status of each function (result of logical links, status bit) or the data of specific registers in real-time mode.

For example, if you have selected the programming language LAD in STEP 7 for your presentation, the color of the symbol will indicate a closed switch or an active circuit.

Note

The STEP 7 testing function with program status extends the CPU cycle time!

In STEP 7, you can set up a maximum cycle time increase for CPUs < V2.8. To do this, set process mode and the desired maximum cycle increase for the CPU parameters in STEP 7, HW Config.

On CPUs \geq V2.8, it is **not** necessary to adjust the maximum cycle time increase, since the influence on the cycle time can usually be neglected on these CPUs when process mode is set.

- Stepping mode

When testing in stepping mode, you can process your program instructions in sequence (= single-step) and set breakpoints.

This is **only** possible in testing mode and **not** in process mode.

However, for CPUs \geq V2.8, the debugging and process mode parameters are not configured in HW Config since the changeover is made directly in the LAD/FBD/STL editor under "Debug/Mode".

Note

Number of blocks and breakpoints that can be monitored with status block

- For CPUs \geq V2.8

With these CPUs, you can monitor two blocks at the same time and set up to four breakpoints in stepping mode.

- All other CPUs of the range of validity

With these CPUs, you can monitor one block set up to two breakpoints in stepping mode.

Debugging functions of the software: Forcing variables

The Force function can be used to assign the variables of a user program or CPU (also: inputs and outputs) constant values which can not be overwritten by the user program.

For example, you can use it to jumper sensors or switch outputs permanently, irrespective of the user program.

! DANGER

This could result in severe injury or even death, and damage to property. Incorrect use of the Force function could result in death or severe injury, and damage to machinery or even the entire plant. Always follow the safety instructions in the *STEP 7 manuals*.

! DANGER

Forcing with S7-300 CPUs

The force values in the process image of the **inputs** can be overwritten by write commands (such as T IB x, = I x.y, Copy with SFC, etc.) and by read I/O commands (such as L PIW x) in the user program, or by write PG/OP functions! Outputs initialized with forced values only return the forced value if not accessed by the user program via peripheral write instructions (TPQB x, for example) or by PG/OP write functions!

Always ensure that forced values in the I/O process image cannot be overwritten by the user program or PG/OP functions!

With S7-300 CPUs, forcing corresponds to "cyclical controlling"

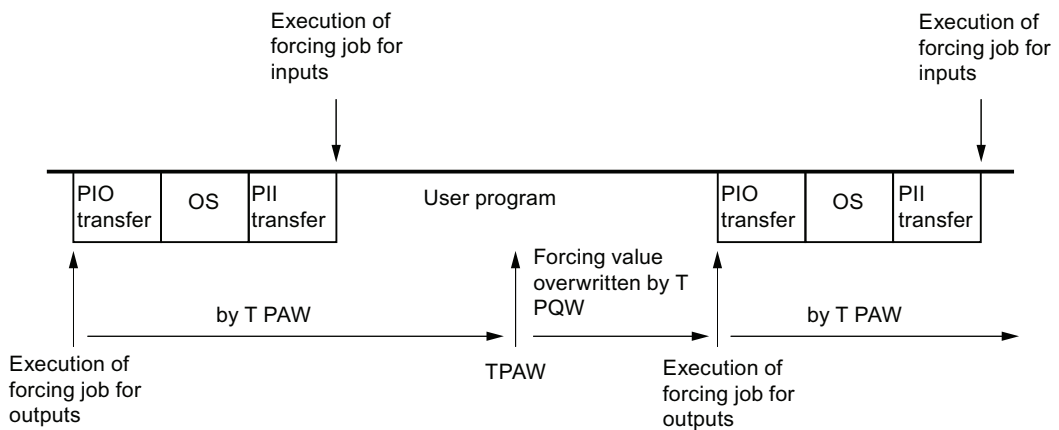

OS: Operating system processing

Figure 10-1 Principle of forcing in S7-300 CPUs

Differences between forcing and modifying variables

Table 10- 2 Differences between forcing and modifying variables

Characteristics/function	Forcing	Modifying variables
Memory bit (M)	-	Yes
Timers and counters (T, C)	-	Yes
Data blocks (DB)	-	Yes
Inputs and outputs (I, O)	Yes	Yes
Peripheral inputs (PI)	-	-
Peripheral outputs (PO)	-	Yes
User program can overwrite modify/force values	Yes	Yes
Maximum number of force values	10	-
Power off retentive	Yes	No

Note

Forcing process image partitions

It is not possible to force inputs and outputs of the process image partition.

Reference

Details on debugging functions of the software are available in the *STEP 7 Online Help* and in the *Programming with STEP 7 Manual*.

For additional information on the cycle times, please refer to the "Cycle time" chapter.

10.5 Overview: Diagnostics

Introduction

Especially in the commissioning phase of a system, errors can occur. Tracking these errors might be a time-consuming effort, because errors can occur both on the hardware and software side. Here, the multitude of testing functions ensures commissioning without problems.

Note

Errors during **operation** are almost always a result of faults or damage to the hardware.

Type of error

Errors the S7 CPUs can recognize and to which you can react with the help of organization blocks (OBs) can be split into the following categories:

- Synchronous error: Errors you can relate to a specific point in the user program (error when accessing a peripheral module, for example).
- Asynchronous error: Errors you can **not** relate to a specific point in the user program (cycle time exceeded, module error, for example).

Troubleshooting

Programming with foresight and, above all, knowledge and proper handling of diagnostic tools puts you into an advantageous position in error situations:

- You can reduce the effects of errors.
- It makes it easier for you to locate errors (by programming error OBs, for example).
- You can limit downtimes.

Diagnostics with LED display

SIMATIC S7 hardware offers diagnostics with LEDs.

Table 10- 3 These LEDs are implemented in three colors:

LED color	State of CPU	Example
Green	Regular operation	Power is on
Yellow	Non-regular operating status	Forcing is active
Red	Fault	Bus error
LED flashing	Special event	CPU memory reset

Table 10- 4 Operation of the LEDs on PROFINET differs as follows compared to the table above:

LED designation and color			Meaning
LINK Color: Green	RX/TX Color: Yellow	LINK/RX/TX Color: Green/yellow	
Off	Off	Off	No other device is connected with the integrated PROFINET interface of the CPU.
On	Off	Green	Another device (in most cases a switch) is connected to the integrated PROFINET interface of the CPU, and the physical connection is in place. No activity: No data is transferred via the integrated PROFINET interface of the CPU.
On	On	Yellow	Activity: Data are transferred via the integrated PROFINET interface of the CPU. Note: The LED flickers when low data volumes are transferred.

Reference

Notes on diagnostics of I/O modules capable of diagnostics are found in the relevant Manual.

Diagnostic buffer

If an error occurs, the CPU writes the cause of error to the diagnostic buffer. In STEP 7 you use the programming device to read the diagnostic buffer. This location holds error information in plain text.

Other modules capable of diagnostics can be equipped with their own diagnostic buffer. In STEP 7 (HW Config -> Diagnosing hardware), you can use the programming device to read this buffer.

Diagnosable modules without diagnostic buffer write their error information to the CPU's diagnostic buffer.

The CPU responds to an error or interrupt event (for example, a diagnostics interrupt of an I/O module) by going into STOP, or you can also choose to respond to these events in the user program by means of error or interrupt OBs. For a diagnostics interrupt you would call OB82.

Diagnostics of field devices on PROFINET

Additional information:

- *PROFINET System Description System Manual.*
- *From PROFIBUS DP to PROFINET IO Programming Manual*

The topics in the next chapters are focused on the diagnostics of local or distributed modules on PROFIBUS.

Diagnostics with system functions

If the following CPUs are used, we recommend that you use the more user-friendly SFB 54 RALRM (called in diagnostic OB82) to evaluate the diagnostics from centralized or distributed modules or DP slaves:

CPU	As of firmware version
31xC, 312, 314, 315-2 DP	V2.0.0
314C-2 PN/DP	V3.3
315-2 PN/DP	V2.3.0
317-2 DP	V2.1.0
317-2 PN/DP	V2.2.0
319-3 PN/DP	V2.4.0

Additional options for diagnostics with system functions are listed below:

- Using **SFC 51 "RDSYSST"** to read an SSL partial list or an extract thereof.
- Reading the diagnostic data (slave diagnostics) of a DP slave, using **SFC 13 "DPNRM_DG"**

Every DP slave provides slave diagnostic data according to EN 50 170 Volume 2, PROFIBUS. You can use SFC 13 "DPNRM_DG" to read these diagnostic data. Error information is stored in hex code. Refer to the relevant module manual for information on the meaning of the read code.

For example, the entry of the value 50H (= dual 0101 0000) in byte 7 of the slave diagnostics for the distributed I/O module ET 200B indicates a faulty fuse or missing load voltage in channel group 2 and 3.

- Reading data records by calling **SFC52 "RDREC"**

You can call SFC52 "RDREC" (read record) to read a specific data record from the addressed module. Data records 0 and 1 are especially suitable for reading diagnostic information from a diagnosable module.

Data record 0 contains 4 bytes of diagnostic data describing the current state of a signal module. Data record 1 contains the 4 bytes of diagnostic data also stored in data record 0, plus module-specific diagnostic data.

- Reading out the start information of the current OB, using the **SFC 6 "RD_SINFO"**

Error information is also found in the start information of the relevant error OB.

You can use SFC 6 "RD_SINFO" (read start information) to read the start information of the OB that was last called and not yet processed completely, and of the start-up OB that was last called.

- Triggering detection of the bus topology in a DP master system with the **SFC103 "DP_TOPOL"**

The diagnostics repeater improves the ability to locate faulty modules or an interruption on the DP cable when failures occur in ongoing operation. It operates in slave mode and is capable of logging faults based on the determination of the DP segment topology.

You can use SFC103 "DP_TOPOL" to trigger the identification of the bus topology of a DP master system by the diagnostic repeater. The SFC 103 is described in the corresponding *STEP 7 Online Help* and in the *System Software S7300/400, System and Standard Functions Reference Manual*. The diagnostic repeater is described in the manual *Diagnostic Repeater for PROFIBUS DP*.

10.6 Diagnostics functions available in STEP 7

Diagnostics using the "Diagnosing Hardware" function

Locate the cause of a module error by viewing the online information on the module. You can locate the cause of an error in the user program cycle with the help of the diagnostic buffer and of the stack content. You can also check whether a user program will run on a specific CPU.

Hardware diagnostics give you an overview of the PLC status. In an overview representation, a symbol can display the error status of every module. A double-click on the faulty module opens detailed error information. The scope of this information depends on the specific module. You can view the following information:

- General information about the module (e.g. order number, version, designation) and the module status (e.g. malfunction).
- Display of module errors (e.g. channel errors) on central I/O devices, PROFIBUS DP slaves, or PROFINET IO devices.
- Display of messages from the diagnostic buffer.
- Maintenance information: Maintenance demanded and maintenance required
- The information also includes diagnostics data for the PROFINET interface.

For CPUs you can also view the following module status information:

- Cause of an error in the user program cycle.
- Indication of the cycle time (longest, shortest and last cycle).
- Options and utilization of MPI communication.
- Indication of performance data (number of possible I/O, memory bits, counters, timers and blocks).
- Diagnostics (e.g. network connection, communication diagnostics and statistics) of the PROFINET interface and ports

For details on diagnostic functions in STEP 7 and on procedures, refer to the *Programming with STEP 7 Manual* and to the *HW Config Online Help*.

10.7 Network infrastructure diagnostics (SNMP)

Availability

As an open standard, you can use any SNMP-based systems or software solutions for diagnostics in PROFINET.

Network diagnostics

SNMP (Simple Network Management Protocol) makes use of the connectionless UDP transport protocol. It consists of two network components, similar to the client/server model. The SNMP manager monitors the network nodes and the SNMP agents collect the various network-specific information in the individual network nodes and stores it in a structured form in the **MIB** (Management Information Base). This information allows a network management system to run detailed network diagnostics.

MIB

An MIB (Management Information Base) is a data base of a device. SNMP clients access this data base in the device. The S7 device family supports, among others, the following standard MIBs:

- MIB II, standardized in the RFC 1213
- LLDP MIB, standardized in the international standard IEE 802.1AB
- LLDP PNIO-MIB, standardized in the international IEC standard 61158-6-10

Detecting the network topology

LLDP (Link Layer Discovery Protocol) is a protocol that is used to detect the closest neighbors. It enables a device to send information about itself and to save information received from neighboring devices in the LLDP MIB. This information can be looked up via the SNMP. This information allows a network management system to determine the network topology.

Integrating HMI devices via the SNMP OPC server

Configuration of the OPC server is integrated in the STEP 7 hardware configuration application. The communication with the OPC server is carried out without an S7 connection. You therefore do not need to configure S7 connections.

Stations that have already been configured in the STEP 7 project can be transferred directly. As an alternative to STEP 7, the configuration can also be run with the NCM PC (included on the SIMATIC NET CD) or can be determined automatically and transferred to the project configuration.

Use of SNMP in the SIMATIC NET environment

SNMP-compliant devices from the SIMATIC NET family can be monitored and operated via a conventional standard Internet browser.

The management system known as web-based management offers a range of device-specific information (network statistics, status of redundant supply, for example).

Diagnostics with the SIMATIC NET SNMP OPC server

The SNMP-OPC-Server software facilitates diagnostics and parameter assignment actions on any SNMP device, even including HMI devices which cannot read SNMP variables from other devices.

The OPC server uses the SNMP protocol to exchange data with these devices.

All information can be integrated into OPC compatible systems such as the HMI system WinCC. This enables process and network diagnostics to be combined in the HMI system.

Uses of SNMP

SNMP can be used as follows:

- By users, to integrate network diagnostics into a central HMI/SCADA system using the SNMP OPC server
- By the IT administration of machines and plant owners to monitor their Industrial Ethernet network using standard network management systems.
- By the IT administration, to primarily monitor the office network, but often also the automation network using standard network management systems (for example, HP Open view).

Additional information

Information relating to SNMP in the network management standardization group can be found at Internet (<http://www.snmp.org/>).

Additional information on SNMP can be found on the Internet (<http://www.profibus.com/>).

Additional information on SNMP OPC servers can be found on the Internet (http://www.automation.siemens.com/net/html_76/produkte/040_snmp.htm).

10.8 Diagnostics using status and error LEDs

10.8.1 Introduction

Diagnostics with LEDs is an initial tool for error localization. Usually, you evaluate the diagnostic buffer for further error localization.

The buffer contains plain text information on the error that has occurred. For example, you will find the number of the appropriate error OB here. You can prevent the CPU from going into STOP mode by generating this OB and downloading it to the CPU.

10.8.2 Status and error displays of all CPUs

Status and error displays

LED						Meaning
SF	MAINT	DC5V	FRCE	RUN	STOP	
Off	Off	Off	Off	Off	Off	No power supply to the CPU. Remedy: Check whether the power supply module is connected to mains and switched on.
Off	X	On	X	Off	On	The CPU is in STOP mode. Remedy: Start the CPU.
On	X	On	X	Off	On	The CPU is in STOP mode as a result of error. Remedy: refer to the tables below, evaluation of the SF LED
X	X	On	X	Off	Flashes (0.5 Hz)	The CPU requests memory reset.
X	X	On	X	Off	Flashes (2 Hz)	The CPU executes memory reset.
X	X	On	X	Flashes (2 Hz)	On	The CPU is in startup mode.
X	X	On	X	Flashes (0.5 Hz)	Flashes (0.5 Hz)	During transmission of the MC7 blocks from the load memory to the work memory, STOP and RUN flash at 0.5 Hz until STOP mode is reached.
X	X	On	X	Flashes (0.5 Hz)	On	The CPU was halted by a programmed break point. For details, refer to the <i>Programming with STEP 7</i> Manual.
On	X	On	X	X	X	Hardware or software error Remedy: refer to the tables below, evaluation of the SF LED

LED						Meaning
SF	MAINT	DC5V	FRCE	RUN	STOP	
X	On	X	X	X	X	For IRT mode of a PROFINET IO system: <ul style="list-style-type: none"> • Failure of the sync master in a sync domain • Synchronization loss at the own station (for example, due to sync master failure) • Synchronization loss at a connected PROFINET IO device (for example, due to sync master failure) Other PROFINET IO maintenance requirements (for example, excess attenuation of fiber-optic cables) For media redundancy (MRP): <ul style="list-style-type: none"> • Missing or interrupted connection between ring ports • Failure of an MRP client on the ring • If several redundancy managers exist
X	X	X	On	X	X	You have enabled the Force function. For additional information, refer to the <i>Programming with STEP 7</i> manual.
X	X	X	Flashes (2 Hz)	X	X	Node flashing test was activated.
Flashes	X	Flashes	Flashes	Flashes	Flashes	Your CPU has an internal system error. The procedure is as follows: <ol style="list-style-type: none"> 1. Set the mode selector switch to STOP. 2. Perform POWER ON/OFF. 3. Read the diagnostics buffer with STEP 7. 4. Read out the service data for CPUs \geq V2.8 (see chapter "Reading/saving service data (Page 205)") 5. Contact your local SIEMENS partner.
Flashes (2 Hz)	Off	Off	Off	Off	Off	CPU without valid firmware Remedy: Update the firmware via Micro Memory Card, see chapter Firmware update using a Micro Memory Card (Page 192)
X: This status is irrelevant to the current CPU function.						

Reference

- Details on the OBs and on SFCs required for their evaluation can be found in the *STEP 7 Online Help* and in the Manual *System Software for S7-300/400 - System and Standard Functions*.

10.8.3 Evaluating the SF LED in the case of software errors

Evaluation of the SF LED (Software error)

Possible problem	CPU reaction	Possible remedies
TOD interrupt is enabled and triggered. However, the appropriate OB is not loaded. (Software/parameter assignment error)	Call of OB85. CPU goes into STOP if OB85 is not loaded.	Load OB10 (OB number is apparent from the diagnostic buffer).
Start time of the enabled TOD interrupt was jumped, e.g. by advancing the internal clock.	Call of OB80. goes into STOP if OB80 is not loaded	Disable the TOD interrupt before you set the time-of-day with SFC 29.
Delay interrupt triggered by SFC 32. However, the appropriate OB is not loaded. (Software/parameter assignment error)	Call of OB85. CPU goes into STOP if OB85 is not loaded.	Load OB 20 or 21 (CPU 317 only) (the OB number can be viewed in the diagnostic buffer).
Process interrupt is enabled and triggered. However, the appropriate OB is not loaded. (Software/parameter assignment error)	Call of OB85. CPU goes into STOP if OB85 is not loaded.	Load OB40 (OB number is apparent from the diagnostic buffer).
Status interrupt is generated, but the appropriate OB55 is not loaded.	Call of OB85. CPU goes into STOP if OB85 is not loaded.	Load OB55
Update alarm is generated, but the appropriate OB 56 is not loaded.	Call of OB85. CPU goes to STOP if OB 85 is not loaded.	Load OB56
Vendor-specific alarm is generated, but the appropriate OB57 is not loaded.	Call of OB85. CPU goes into STOP if OB85 is not loaded.	Load OB57
Access to missing or defective module upon updating the process image (software or hardware error)	Call OB 85 (depending on the configuration in HW Config). CPU goes into STOP if OB 85 is not loaded.	Load OB85, the start information of the OB contains the address of the relevant module. Replace the relevant module or eliminate the program error.
The cycle time was exceeded. Probably too many interrupt OBs called simultaneously.	Call of OB80. CPU goes into STOP if OB80 is not loaded. The CPU switches to STOP despite loaded OB80 if the doubled cycle time was exceeded without retriggering cycle time.	Extension of the cycle time (STEP 7 – Hardware configuration), changing the program structure. Remedy: Retrigger cycle time monitoring by calling SFC 43
Programming error <ul style="list-style-type: none"> • Block not loaded • Wrong block number • Wrong timer/counter number • Read/write access to wrong area • etc. 	Calls OB121. CPU does not STOP if OB121 is loaded.	Eliminate the programming error. The STEP 7 testing function helps you to locate the error.
I/O access errors An error has occurred when module data was accessed	Calls OB122. CPU does not STOP if OB122 is loaded.	Check the addressing of the modules in HW Config or whether a module, a DP slave, or a PROFINET IO device has failed.
Global data communication error, such as insufficient length of the DB for global data communication.	Call of OB87. CPU goes into STOP if OB87 is not loaded.	Check global data communication in STEP 7. If required, correct the DB size.

Tip:

- You can use SFC 39 to disable all interrupts and asynchronous error events.

Note

The shorter the selected cyclic interrupt period, the more likely it is that cyclic interrupt errors will occur. You must take into account the operating system times of the CPU in question, the user program runtime and extension of the cycle time by active PG functions, for example.

Reference

Details on the OBs and on the SFCs required for their evaluation are available in the *STEP 7 Online Help* and in the *System Software for S7-300/400 - System and Standard Functions Reference Manual*.

10.8.4 Evaluating the SF LED in the case of hardware errors

Evaluation of the SF LED (Hardware error)

Possible problem	CPU reaction	Possible remedies
A module was removed or inserted while the system was in RUN.	CPU goes into STOP.	Screw-tighten the modules and restart the CPU.
A distributed module was removed or inserted on PROFIBUS DP while the system was in RUN.	Call of OB86. CPU goes into STOP if OB86 is not loaded. When the module is integrated by means of GSD file: Call of OB 82. CPU goes into STOP when OB 82 is not loaded.	Load OB86 or OB82.
A distributed module was removed or inserted on PROFINET IO while the system was in RUN.	Call of OB83. CPU goes into STOP if OB83 is not loaded. OB 86 is also called when one or several modules of an ET 200S (IO device) are removed or inserted while the system is in RUN. CPU switches to STOP if OB 86 is not loaded.	Load OB 83 and OB 86.
A diagnosable module reports a diagnostic interrupt.	Call of OB82. CPU goes into STOP if OB82 is not loaded.	Reaction to the diagnostic event, based on the module configuration.
Attempt to access a missing or faulty module. Loose connector (software or hardware error).	Call of OB85, if access was attempted during update of the process image (OB 85 call must be enabled accordingly in the parameters). Call of OB 122 during direct I/O access. CPU switches to STOP if the OB is not loaded.	Load OB 85, the start information of the OB contains the address of the relevant module. Replace the relevant module, tighten the plug or eliminate the program error.

Possible problem	CPU reaction	Possible remedies
Faulty SIMATIC MMC.	The CPU goes into STOP mode and requests memory reset.	Replace the SIMATIC MMC, reset CPU memory, transfer the program again, then set the CPU to RUN mode.
A port interconnection was configured, however, a partner is not available at the port, or an incorrect partner was detected.	A missing or incorrect partner device on the port of the PROFINET interface leads to a corresponding entry in the diagnostics buffer and message in the communication diagnostics of the port. If the call of an OB 82 for communication interrupts of the PROFINET interface is enabled in HW Config, then OB 82 will be called if a relevant event occurs while the IM is in RUN mode.	Set up a connection to the correct partner.
The CPU is operated as intelligent device on an IO controller (which can also be a CPU) on a PROFINET IO subnet. One of the two communication partners goes into STOP mode (or is in STOP mode).	IO controller in RUN and intelligent device in STOP mode: <ul style="list-style-type: none"> • Direct I/O access to inputs/ outputs of the application transfer areas to intelligent devices leads to access errors (call of OB 122) in the IO controller. • If the application transfer areas are in the process image and you configured a call of OB 85 for process image transfer errors in the parameters, this OB 85 will be called. IO controller in STOP and intelligent device in RUN mode: <ul style="list-style-type: none"> • Direct I/O access to inputs/outputs of the user transfer areas to the controller leads to access errors (call of OB 122) in the intelligent device. • If the user transfer areas are in the process image and you configured a call of OB 85 for process image transfer errors in the parameters, this OB 85 will be called. 	Load OB 85 or OB 122

Reference

Details on the OBs and on the SFCs required for their evaluation are available in the *STEP 7 Online Help* and in the *System Software for S7-300/400 - System and Standard Functions Reference Manual*.

10.8.5 Status and error indicators: CPUs with DP interface

Description of the BF, BF1 and BF2 LEDs

Table 10- 5 LEDs BF, BF1 and BF2

LED					Meaning
SF	5 VDC	BF	BF1	BF2	
On	On	On/flashes	-	-	PROFIBUS DP interface error. Remedy: See the table below
On	On	-	On/flashes	X	Error at the first PROFIBUS DP interface of CPU 317 or CPU 319-3 PN/DP. Remedy: See the table below.
On	On	-	X	On/flashes	Error at the second PROFIBUS DP interface of the CPU 317-2 DP or CPU 319-3 PN/DP. Remedy: See the tables below

Explanation of the State X:

The LED can assume the *On* or *Off* state. This status, however, is irrelevant for the current CPU function.

Table 10- 6 BF LED is lit

Possible problem	CPU reaction	Possible remedies
<ul style="list-style-type: none"> • Bus fault (hardware fault). • DP interface error. • Different transmission rates in multiple DP master mode. • If the DP slave / master interface is active: short-circuit on the bus. • With passive DP slave interface: transmission rate search, i.e. there are no other active nodes on the bus (a master, for example) 	<p>Call of OB 86, if the CPU is in RUN mode and communication between the DP master and DP slave functioned properly before the error occurred. CPU switches to STOP if OB 86 is not loaded.</p>	<ul style="list-style-type: none"> • Check the bus cable for short-circuit or breaks. • Analyze the diagnostic data. Edit the configuration.

Table 10-7 BF LED flashes

Possible problem	CPU reaction	Possible remedies
<p>The CPU is DP master:</p> <ul style="list-style-type: none"> • Failure of a connected station • At least one of the configured slaves cannot be accessed. • Incorrect configuration 	<p>Call of OB 86, if CPU is in RUN mode and operated DP slaves before the error occurred.</p> <p>CPU switches to STOP if OB 86 is not loaded.</p>	<p>Verify that the bus cable is connected to the CPU, or that the bus is not interrupted.</p> <p>Wait until the CPU has completed its startup. If the LED does not stop flashing, check the DP slaves or evaluate the diagnostic data for the DP slaves.</p>
<p>The CPU is active DP slave:</p> <p>Possible causes:</p> <ul style="list-style-type: none"> • The watchdog time has elapsed. • PROFIBUS DP communication is down. • Wrong PROFIBUS address. • Incorrect configuration 	<p>Call of OB 86, if CPU is in RUN mode and communicated as a DP slave with the DP master before the error occurred.</p> <p>CPU switches to STOP if OB 86 is not loaded.</p>	<ul style="list-style-type: none"> • Check the CPU. • Verify that the bus connector is properly seated. • Check for breaks in the bus cable to the DP master. • Check the configuration data and parameters.

Reference

Details on the OBs and on the SFCs required for their evaluation are available

- in the *STEP 7 Online Help*
- in the *System Software for S7-300/400, System and Standard Functions Reference Manual*

10.8.6 Status and error indicators: CPUs with PROFINET interface for the S7-300

Status and Error Indicators: PROFINET devices

Note

The RX and TX LEDs can also be grouped in one LED, e.g., as on CPU 317-2 PN/DP. The RX/TX LED on this device is located, for example, under the front cover.

LED	LED status			Description of the status
	Not lit	Flashes	Lit	
LINK	–	–	X	There is no connection between the PROFINET interface of your PROFINET device and a communication partner in the Ethernet (a switch, for example).
	–	X	–	A "Node flash test" initiated in SIMATIC Manager activates flashing of the LINK LED only for the IO devices. The LINK LEDs can also be set to flash on CPUs, for example, by calling the "Search network" function in HW Config (PLC → Ethernet → Edit Ethernet node → Search → Flash). Comment: On CPUs, the common "Node flash test" initiates flashing of the FORCE LED.
	X	–	–	The Ethernet connection between the PROFINET interface of the PROFINET device and the communication partner is down.
RX	–	–	X (flickers)	At the current time, data are being received from a communication partner on Ethernet via PROFINET interface of the PROFINET device.
	X	–	–	No data are currently received via the PROFINET interface.
TX	–	–	X (flickers)	Data are currently sent to a communication partner on Ethernet via the PROFINET interface of the PROFINET device.
	X	–	–	No data are currently transmitted via the PROFINET interface.
MAINT	X	–	–	There is currently no maintenance request pending.
	–	–	X	A maintenance request is pending
BF2 or BF3	–	–	X	Error on the PROFINET interface, communication no longer possible (for example, with a CPU as IO controller, when the connection to the switch is down) Remedy: See the table below
	–	X	–	The BF LED always flashes if the communication cannot be set up correctly to all devices on the PROFINET IO controller (for example, station failure of one or several IO devices). However, communication is always possible via a port of the PROFINET interface (link to a partner device is active). On a CPU that is operated as intelligent device, the BF LED keeps flashing until at least one controller has correctly set up communication with this I-device. Remedy: See the table below
	X	–	–	No error at the PROFINET interface

Remedy of faults at the PROFINET interface - BF2/BF3 LED is lit

Table 10- 8 BF2/BF3 LED is lit

Possible problem	Reaction based on the example of a CPU	Possible remedies
<ul style="list-style-type: none"> • Bus fault (no cable connection to a subnet/ switch) • Wrong transmission speed • Full duplex mode not set 	<p>Call of OB 86, if the CPU is in RUN mode and, before the error had occurred, operated the PROFINET IO devices which have now failed.</p> <p>CPU switches to STOP if OB 86 is not loaded.</p>	<ul style="list-style-type: none"> • Check the bus cable for a short-circuit or break. • Check that the module is connected to a switch and not to a hub. • Check that data is being transmitted at 100 Mbit/s and in full duplex mode. • Analyze the diagnostic data. Reconfigure or correct the configuration.

Remedy of faults at the PROFINET interface of an IO controller - BF2/BF3 LED flashes

Table 10- 9 BF2/BF3 LED flashes at a PROFINET IO controller

Possible problem	Reaction based on the example of a CPU	Possible remedies
<ul style="list-style-type: none"> • Failure of a connected IO device • At least one of the assigned IO devices cannot be addressed • Incorrect configuration 	<p>Call of OB 86, if the CPU is in RUN mode and, before the error has occurred, operated the PROFINET IO devices which now failed.</p> <p>CPU switches to STOP if OB 86 is not loaded.</p>	<ul style="list-style-type: none"> • Check that the Ethernet cable is connected to the module or whether the bus is interrupted. • Wait until the CPU has completed its startup. If the LED does not stop flashing, check the IO devices or evaluate its diagnostic information. • Verify that the configured device name matches its actually assigned name. • Check whether the connected IO devices have different device names and IP addresses.

Troubleshooting errors on the PROFINET interface of an I-device - BF2/BF3 LED flashes

Table 10- 10 BF2/BF3 LED flashes on an I-device

Possible problem	Reaction based on the example of a CPU	Possible remedies
In a configuration as intelligent device without IO subsystem:		
<ul style="list-style-type: none"> • Incorrect IP address. • Incorrect configuration • Incorrect parameter assignment • IO controller missing/ switched off, but there is an Ethernet connection. • In Shared I-Device mode: All configured IO controllers are not available/ switched off, but there is an Ethernet connection (link to a neighboring device established). • Incorrect or missing device name • The watchdog time has elapsed. • The CPU is an I-device and communication with the higher-level controller fails 	<p>Call of OB 86 if the CPU is in RUN mode and user data communication with the higher-level controller(s) fails.</p> <p>The CPU goes into STOP mode if OB 86 is not loaded.</p> <p>When the CPU is operated as Shared I-Device, the BF LED flashes only if communication with both higher-level controllers has failed.</p>	<ul style="list-style-type: none"> • Check that the Ethernet cable is correctly connected. • Check whether the Ethernet cable to the controller is interrupted. • Check the configuration, parameter assignment, and particularly the IP addresses and device names. • Power up the IO controller. • Check whether the target configuration matches the actual configuration. • Check whether the hardware connection for communication is interrupted. • Wait until the CPU has completed its startup. If the LED does not stop flashing, check the IO controllers and evaluate the diagnostics buffers of the IO controllers and intelligent device.
Additional check for a configuration as intelligent device with IO subsystem:		
<ul style="list-style-type: none"> • Failure of a connected IO device • At least one of the assigned IO devices cannot be addressed • Incorrect configuration 	<p>Call of OB 86, if the CPU is in RUN mode and, before the error has occurred, operated the PROFINET IO devices which now failed.</p> <p>The CPU goes into STOP mode if OB 86 is not loaded.</p>	<ul style="list-style-type: none"> • Check that the Ethernet cable is connected to the module or whether the bus is interrupted. • Wait until the CPU has completed its startup. If the LED does not stop flashing, check the IO devices, or evaluate their diagnostic information. • Verify that the configured device name matches its actually assigned name. • Check whether the connected IO devices have different device names and IP addresses.

10.8.7 Status and error indicators: PROFINET IO Devices

Troubleshooting errors on the PROFINET interface of an IO device and in mixed mode with IO controller/I-device - BF LED flashes

Table 10- 11 BF LED flashes on a PROFINET IO device

Possible problem	Possible remedies
<ul style="list-style-type: none"> The IP address is incorrect Incorrect configuration Incorrect parameter assignment IO controller not found/switched off, but there is an Ethernet connection. In Shared I-Device mode: All configured IO controllers are not available or are switched off, but there is an Ethernet connection (link to a neighboring device established) Incorrect or missing device name The watchdog time has elapsed. In IRT mode with "high performance": Connection to the sync master is down 	<ul style="list-style-type: none"> Check that the Ethernet cable is correctly connected. Check whether the Ethernet cable to the controller is interrupted. Check the configuration data and parameters. On the IO device: Switch on the IO controller. Check whether the expected configuration matches the actual configuration. Check the physical communication connection for interruption

Tip: Identification of the PROFINET device in the cubicle

When they are first commissioned, PROFINET IO devices must be assigned a device name. In STEP 7/HW Config, you can make the LINK LED of a PROFINET IO device you are naming flash using **PLC >Ethernet > Assign device name** . This allows you, for example, to clearly identify a PROFINET IO device among several identical devices in a control cabinet.

Maintenance LED

This LED indicates that a maintenance request is pending, for example, loss of synchronization of the own station.

For additional information, refer to the STEP 7 online help.

10.9 Diagnostics of DP CPUs

10.9.1 Diagnostics of DP CPUs operating as DP Master

Evaluate diagnostics in the user program

The figure below illustrates the procedure for evaluating diagnostics data in the user program.

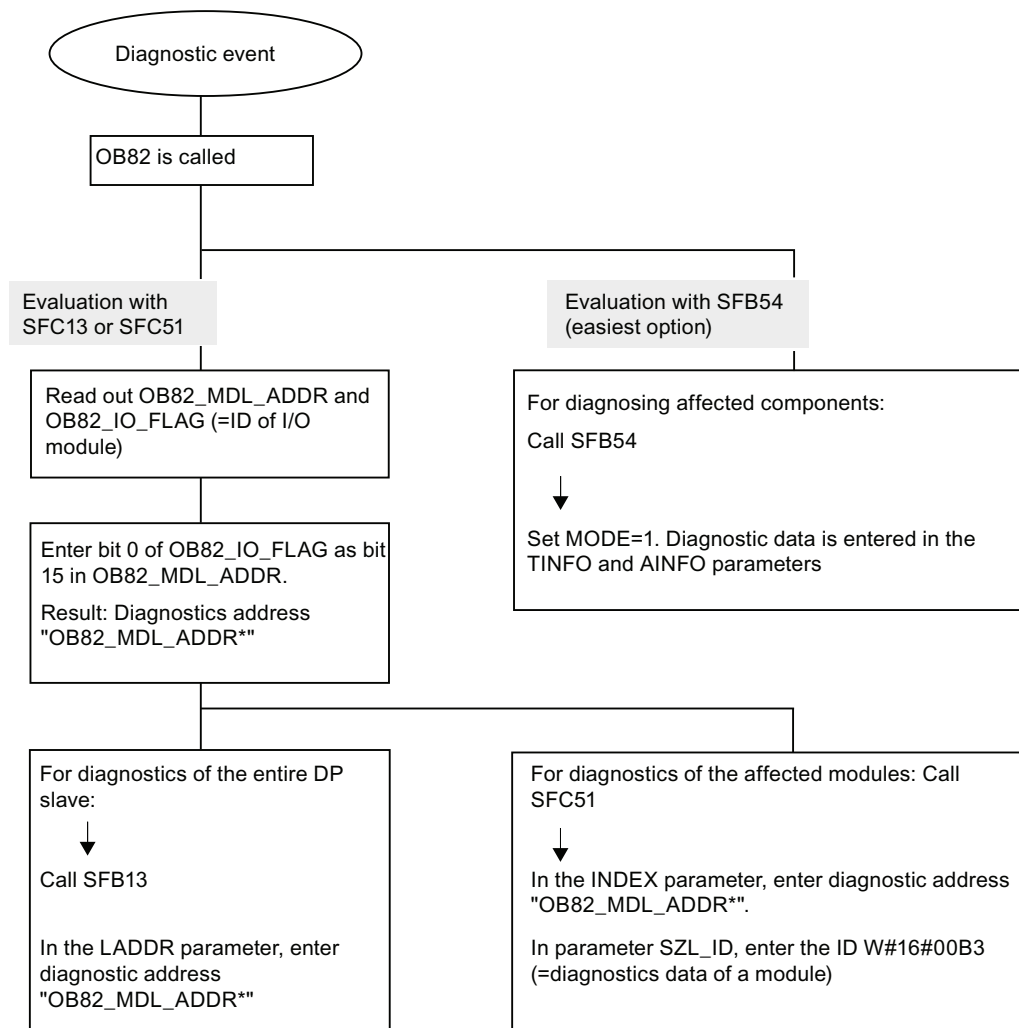

Note:

SFC 13 is asynchronous, which means that it may be called multiple times until its state has changed to BUSY=0.

Initial call in OB82, finishing in the cycle

Diagnostic addresses for DP masters and DP slaves

For a CPU 31x-2, you assign diagnostic addresses for PROFIBUS DP. When configuring the project, make sure that the DP diagnostic addresses are assigned once to the DP master and once to the DP slave.

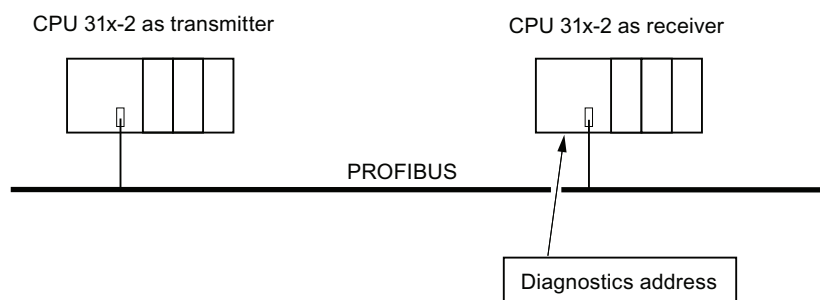

Description of the DP master configuration	Description of the DP slave configuration
<p>When you configure the DP master, assign two different diagnostic addresses for an intelligent slave, that is, one diagnostic address for slot 0, and one for slot 2. Functions of those two addresses:</p> <ul style="list-style-type: none"> • The diagnostic address for slot 0 is used to report in the master all events relating to the entire slave (station substitute), for example, node failure. • The diagnostic address for slot 2 is used to report events concerning this slot. For example, if the CPU is acting as an I-slave, it returns the diagnostic interrupts for operating mode transitions. <p>From now on, these diagnostic addresses is referred to as <i>assigned to the DP master</i>.</p> <p>These diagnostic addresses are used by the DP master to obtain information about the status of the DP slave or about bus interruptions.</p>	<p>When you configure the DP slave, you also assign it a diagnostic address (in the associated DP slave project).</p> <p>Below, this diagnostic address is referred to as <i>assigned to DP slave</i>.</p> <p>This diagnostic address is used by the DP slave to obtain information on the status of the DP master or on bus interruptions.</p>

Event detection

The table below shows how a CPU 31x-2 operating as DP master detects operating mode transitions of a CPU operating as DP slave, or data exchange interruptions.

Table 10- 12 Event detection of CPU 31x2 operating as DP master

Event	What happens in the DP master?
Bus interruption (short-circuit, connector removed)	<ul style="list-style-type: none"> • Call of OB 86 with the message Station failure (incoming event; diagnostic address of Slot 0 of the DP slave that is assigned to the DP master) • With I/O access: call of OB 122 (I/O access error)
DP slave: RUN → STOP	<ul style="list-style-type: none"> • Call of OB 82 with the message Faulty module (incoming event; diagnostic address of Slot 2 of the DP slave that is assigned to the DP master; variable OB82_MDL_STOP = 1)
DP slave: STOP → RUN	<ul style="list-style-type: none"> • Call of OB 82 with the message Module OK (outgoing event; diagnostic address of Slot 2 of the DP slave that is assigned to the DP master; variable OB82_MDL_STOP = 0)

Evaluation in the user program

The table below shows how you can, for example, evaluate RUN to STOP transitions of the DP slave in the DP master.

Table 10- 13 Evaluating RUN to STOP transitions of the DP slave in the DP master

In the DP master	In the DP slave (CPU 31x-2 DP)
Diagnostic addresses: (Example) Master diagnostic address = 1023 Slave diagnostic address = 1022 (Slot 0 of slave) (Diagnostic) address for "Slot 2" = 1021 (Slot 2 of slave)	Diagnostic addresses: (Example) Slave diagnostic address = 422 Master diagnostic address = irrelevant
The CPU calls OB82 with information including the following: <ul style="list-style-type: none"> • OB 82_MDL_ADDR: = 1021 • OB82_EV_CLASS: = B#16#39 (incoming event) • OB82_MDL_DEFECT: = Module fault Tip: The CPU diagnostic buffer also contains this information In the user program, you should also program SFC 13 "DPNRM_DG" for reading out DP slave diagnostic data.	CPU: RUN → STOP The CPU generates a DP slave diagnostics message frame

10.9.2 Reading out slave diagnostic data

The slave diagnostic data is compliant with EN 50170, Volume 2, PROFIBUS. Depending on the DP master, diagnostic data for all DP slaves conforming to standard can be read with STEP 7.

Diagnostic addresses for the receiving station with direct data exchange

For direct data exchange, you assign a diagnostic address in the receiving station:

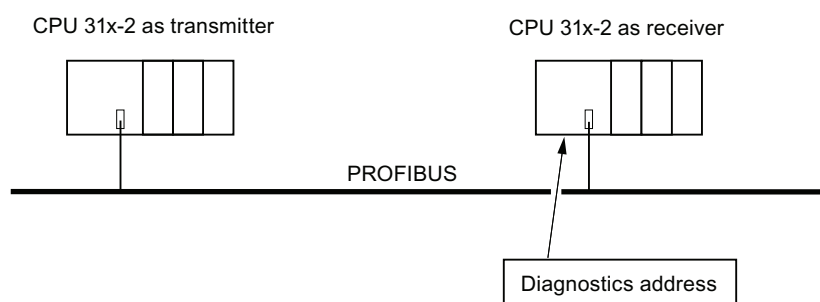

Figure 10-2 PROFIBUS DP diagnostics address

In this figure, you see that assign a diagnostic address to the receiving station in your configuration. The receiving station receives information about the status of the transmitting station or about a bus interruption by means of this diagnostic address.

Reading out the diagnostic data

The table below shows you how the various DP master systems can read diagnostic information from a slave.

Table 10- 14 Reading out diagnostic data in the master system, using STEP 5 and STEP 7

Automation system with DP master	Blocks or registers in STEP 7	Application	Additional Information
SIMATIC S7/M7	"DP Slave Diagnostics" tab	Output of slave diagnostic data in plain text to a STEP 7 user interface	Refer to the keyword <i>Hardware diagnostics</i> in the STEP 7 Online Help and in the <i>Programming with STEP 7 Manual</i>
	SFB 54 "RALRM"	Reading additional interrupt information from a DP slave or local module from the relevant OB.	System and Standard Functions <i>Reference Manual</i>
	SFC13 "DP NRM_DG"	Reading out slave diagnostics (store in the data area of the user program)	System and Standard Functions <i>Reference Manual</i>

Automation system with DP master	Blocks or registers in STEP 7	Application	Additional Information
	SFC 51 "RDSYSST"	Reading SSL sublists. In the diagnostic interrupt, call SFC 51 with the SSL ID W#16#00B4 and then read out the SSL of the slave CPU.	System and Standard Functions <i>Reference Manual</i>
	SFB 52 "RDREC" and SFC 59 "RD_REC"	Reading the data records of S7 diagnostics (stored in the data area of the user program)	System and Standard Functions <i>Reference Manual</i>
	FB 125/FC 125	Evaluating slave diagnostic data	On the Internet (http://support.automation.siemens.com/WW/view/en/387257)
SIMATIC S5 with IM 308-C operating in DP master mode	FB 192 "IM308C"	Reading slave diagnostic data (store in the data area of the user program)	Distributed I/O System ET 200 <i>Manual</i>

Example for reading the slave diagnosis with FB 192 "IM308C"

This shows you an example of how to use FB 192 in the **STEP 5** user program to read out slave diagnostics data for a DP slave.

Assumptions regarding the STEP 5 user program

For this **STEP 5** user program it is assumed that:

- The IM 308-C operating in DP master mode uses the page frames 0 to 15 (number 0 of IM 308-C).
- The DP slave is assigned PROFIBUS address 3.
- Slave diagnostics data should be stored in DB 20. You may also use any other DB.
- Slave diagnostic data consists of 26 bytes.

STEP 5 user program

STL	Explanation
:A DB 30	
:SPA FB 192	
Name :IM308C	
DPAD : KH F800	//Default address range of IM 308-C
IMST : KY 0.3	//IM no. = 0, PROFIBUS address of the DP slave = 3
FCT : KC SD	//function: Read slave diagnostics
GCGR : KM 0	//not evaluated
TYP : KY 0, 20	//S5 data area: DB 20
STAD : KF +1	//Diagnostic data starting at data word 1
LENG : KF 26	//Length of diagnostic data = 26 bytes
ERR : DW 0	//Error code storage in DW 0 of DB 30

Example of reading out S7 diagnostic data with SFC 59 "RD REC"

Here you will find an example of how to use SFC 59 in the STEP 7 user program to read S7 diagnostics data records for a DP slave. The process of reading the slave diagnostics is similar for SFC 13.

Assumptions regarding the STEP 7 user program

Exceptions for this STEP 7 user program:

- Diagnostic data for the input module at address 200_H is to be read.
- Data record 1 is to be read out.
- Data record 1 is to be stored in DB 10.

STEP 7 user program

STL	Explanation
CALL SFC 59	
REQ :=TRUE	//Request to read
IOID :=B#16#54	//Identifier of the address range, here the I/O input
	//Logical address of the module
LADDR :=W#16#200	//Data record 1 is to be read
RECNUM :=B#16#1	//An error code is output if an error occurs
RET_VAL :=MW2	//Read operation not finished
BUSY :=MO.0	//DB 10 is target area for the read data record 1
RECORD :=P# DB10.DBX 0.0 BYTE 240	

Note:

Data is only returned to the target area if BUSY is reset to 0 and if no negative RET_VAL has occurred.

Diagnostics addresses

For a CPU 31x-2, you assign diagnostic addresses for PROFIBUS DP. When configuring the project, make sure that the DP diagnostic addresses are assigned once to the DP master and once to the DP slave.

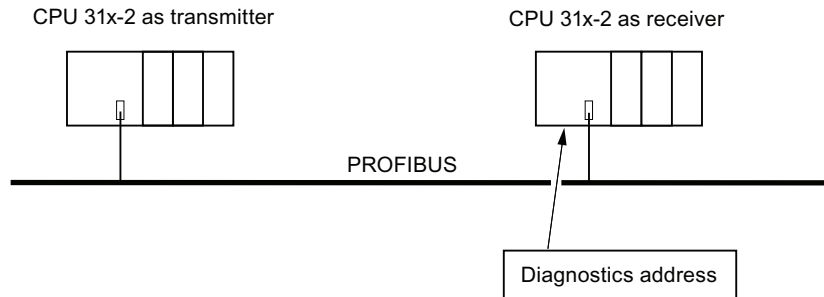

Figure 10-3 PROFIBUS DP diagnostics address

Description of the DP master configuration	Description of the DP slave configuration
<p>When you configure the DP master, assign two different diagnostic addresses for an intelligent slave, that is, one diagnostic address for slot 0, and one for slot 2. Functions of those two addresses:</p> <ul style="list-style-type: none"> • The diagnostics address for slot 0 is used to report in the master all events relating to the entire slave (station substitute), for example, node failure. • The diagnostics address for slot 2 is used to report events concerning this slot. For example, if the CPU is acting as an I-slave, it returns the diagnostic interrupts for operating mode transitions. <p>From now on, these diagnostic addresses is referred to as <i>assigned to the DP master</i>.</p> <p>These diagnostic addresses are used by the DP master to obtain information about the status of the DP slave or about bus interruptions.</p>	<p>When you configure the DP slave, you also assign it a diagnostic address (in the associated DP slave project).</p> <p>Below, this diagnostic address is referred to as <i>assigned to DP slave</i>.</p> <p>This diagnostic address is used by the DP slave to obtain information on the status of the DP master or on bus interruptions.</p>

Event recognition

The table below shows how CPU 31x-2 operating as DP slave recognized operating state transitions or data exchange interruptions.

Table 10- 15 Event recognition of CPUs 31x-2 operating in DP slave mode

Event	What happens in the DP slave?
Bus interruption (short circuit, connector removed)	<ul style="list-style-type: none"> • Calls OB86 with the message Station failure (incoming event; diagnostic address of the DP slave, assigned to the DP slave) • With I/O access: call of OB 122 (I/O access error)
DP master: RUN → STOP	<ul style="list-style-type: none"> • Calls OB82 with the message Faulty module (incoming event; diagnostic address of the DP slave assigned to the DP slave; variable OB82_MDL_STOP = 1)
DP master: STOP → RUN	<ul style="list-style-type: none"> • Call of OB82 with the message Module OK. (outgoing event; diagnostic address assigned the DP slave; variable OB82_MDL_STOP = 0)

Evaluation in the user program

The table below shows how you can, for example, evaluate RUN-STOP transitions of the DP master in the DP slave (see also the previous table).

Table 10- 16 Evaluating RUN-STOP transitions in the DP Master/DP Slave

In the DP master	In the DP slave
Diagnostic addresses: (Example) Master diagnostic address = 1023 Slave diagnostic address in the master system = 1022 (Slot 0 of slave) (Diagnostic) address for "Slot 2" = 1021 (Slot 2 of slave)	Diagnostic addresses: (Example) Slave diagnostic address = 422 Master diagnostic address = irrelevant
CPU: RUN → STOP	→ The CPU calls OB 82 with the following information, for example: <ul style="list-style-type: none"> • OB 82_MDL_ADDR: = 422 • OB82_EV_CLASS: = B#16#39 (incoming event) • OB82_MDL_DEFECT: = Module fault Tip: The CPU diagnostic buffer also contains this information

10.9.3 Interrupts on the DP Master

Interrupts with S7 DP master

Process interrupts from an intelligent slave with SFC 7

In the CPU 31x-2 operating in DP slave mode, you can trigger a user-defined process interrupt from the DP master from the user program.

The call of SFC 7 "DP_PRAL" triggers a call of OB 40 in the user program of the DP master. The SFC 7 allows you to forward interrupt information to the DP master in a double word. This information can then be evaluated in the OB40_POINT_ADDR variable in the OB40. The interrupt information can be programmed user-specific. You will find a detailed description of SFC7 "DP_PRAL" in the *System Software for S7-300/400, System and Standard Functions Reference Manual*.

Setting user-defined interrupts of Intelligent Slaves using SFB 75

In the CPU 31x-2 operating in DP slave mode, you can trigger user-defined interrupts from the user program in the DP master. SFB 75 "SALRM" is used to send a process or diagnostic interrupt from a slot in the transfer area (virtual slot) to the associated DP master from the user program on an intelligent slave. This starts the associated OB on the DP master.

Additional interrupt-specific information may be included. You can read this additional information in the DP master using SFB 54 "RALRM."

Interrupts with another DP master

When CPU 31x-2 operates with another DP master, an image of these interrupts is created in its device-specific diagnostic data. You have to post-process the relevant diagnostic events in the DP master's user program.

Note

In order to allow the evaluation of diagnostics and process interrupts by means of device-specific diagnostics using a different DP master, please note that:

The DP master should be able to save the diagnostics messages to its ring buffer. For example, if the DP master can not save the diagnostic messages, only the last incoming diagnostic message would be saved.

In your user program, you have to poll the relevant bits in the device-specific diagnostic data in cyclic intervals. Make allowances for the PROFIBUS DP bus cycle time, for example, to be able to poll these bits at least once and in synchronism to the bus cycle time.

With an IM 308-C operating in DP master mode, you cannot utilize process interrupts in device-specific diagnostics, because only incoming events are reported, rather than outgoing events.

10.9.4 Structure of the slave diagnostics when the CPU is operated as I-slave

Syntax of the diagnostics datagram for slave diagnostics

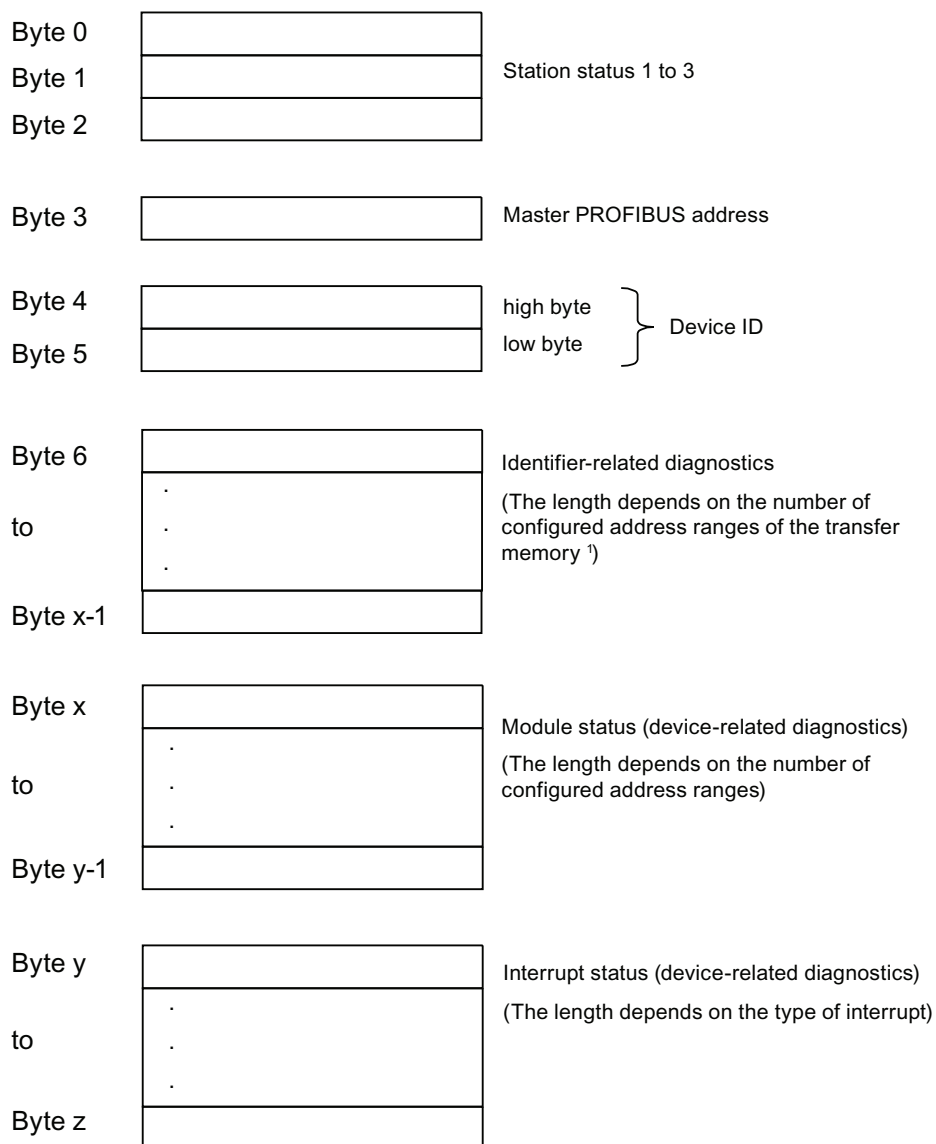

¹Exception: In the case of an incorrect configuration from the DP master, the DP slave interprets 35 configured address ranges (46_H in Byte 6)

Figure 10-4 Structure of slave diagnostic data

Station Status 1

Table 10- 17 Structure of station status 1 (Byte 0)

Bit	Meaning	Remedy
0	1: DP slave cannot be addressed by DP master.	<ul style="list-style-type: none"> Is the correct DP address set on the DP slave? Are the bus connectors connected? Does the DP slave have power? Correct configuration of the RS485 Repeater? Perform a reset on the DP slave.
1	1: DP slave is not ready for data exchange.	<ul style="list-style-type: none"> Wait for the slave to complete start-up.
2	1: Configuration data sent by DP master to the DP slave is inconsistent with slave configuration.	<ul style="list-style-type: none"> Was the software set for the correct station type or DP slave configuration?
3	1: Diagnostic interrupt, generated by a RUN-STOP transition on the CPU or by the SFB 75 0: Diagnostic interrupt, generated by a STOP-RUN transition on the CPU or by the SFB 75	<ul style="list-style-type: none"> You can read the diagnostic data.
4	1: Function is not supported; for example, changing the DP address using software	<ul style="list-style-type: none"> Check configuration data.
5	0: The bit is always "0".	<ul style="list-style-type: none"> -
6	1: DP slave type inconsistent with software configuration.	<ul style="list-style-type: none"> Was the software set for the right station type? (parameter assignment error)
7	1: DP slave was assigned parameters by a DP master other than the DP master currently accessing the DP slave.	<ul style="list-style-type: none"> The bit is always 1 if, for example, you are currently accessing the DP slave via the programming device or a different DP master. <p>The DP address of the parameter assignment master is in the "master PROFIBUS address" diagnostic byte.</p>

Station Status 2

Table 10- 18 Structure of station status 2 (Byte 1)

Bit	Meaning
0	1: The DP slave requires new parameters and configuration.
1	1: A diagnostic message was received. The DP slave cannot resume operation until the error has been cleared (static diagnostic message).
2	1: This bit is always "1" if a DP slave exists with this DP address.
3	1: The watchdog monitor is enabled on this DP slave.
4	1: DP slave has received control command "FREEZE".
5	1: DP slave has received control command "SYNC".
6	0: The bit is always set to "0".
7	1: DP slave is disabled, that is, it has been excluded from cyclic processing.

Station Status 3

Table 10- 19 Structure of station status 3 (Byte 2)

Bit	Meaning
0 to 6	0: These bits are always "0"
7	1: There are more diagnostic messages than the DP slave can save. The DP master cannot enter all diagnostic messages sent from the DP slave in its diagnostic buffer.

Master PROFIBUS address

The "Master PROFIBUS address" diagnostic byte stores the DP address of the DP master:

- that has configured the DP slave and
- that has read and write access to the DP slave

Table 10- 20 Structure of the Master PROFIBUS address (byte 3)

Bit	Meaning
0 to 7	DP address of the DP master that has assigned parameters to the DP slave and has read/write access to that DP slave.
	FF _H : DP slave was not configured by a DP master

Device ID

The device ID is a manufacturer ID containing a code which specifies the type of the DP slave.

Table 10- 21 Structure of the device ID (bytes4, 5)

Byte 4	Byte 5	Device ID for the CPU
81 _H	96 _H	313C-2 DP
81 _H	97 _H	314C-2 DP
81 _H	98 _H	314C-2 PN/DP
81 _H	76 _H	315-2 DP
81 _H	80 _H	315-2 PN/DP
81 _H	94 _H	317-2 DP
81 _H	82 _H	317-2 PN/DP
81 _H	84 _H	319-3 PN/DP

Structure of identifier-related diagnostics of CPU 31x-2/CPU 319-3

Module diagnostics indicate the configured address range of intermediate memory that has received an entry.

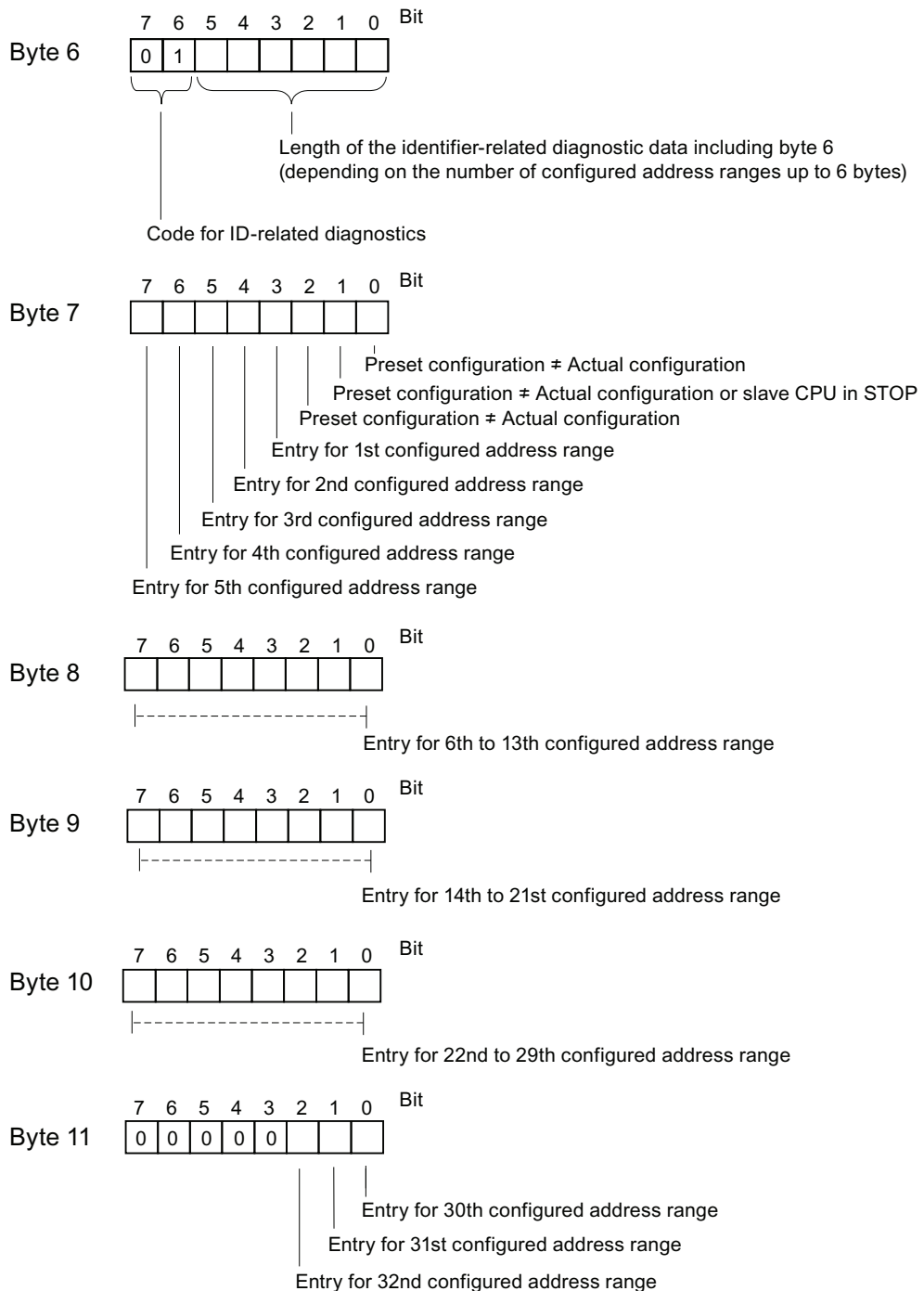

Figure 10-5 Identifier-related diagnostic data

Structure of the module status

The module status reflects the status of the configured address ranges, and provides detailed ID-specific diagnostics with respect to the configuration. The module status follows the identifier-related diagnostics and consists of a maximum of 13 bytes.

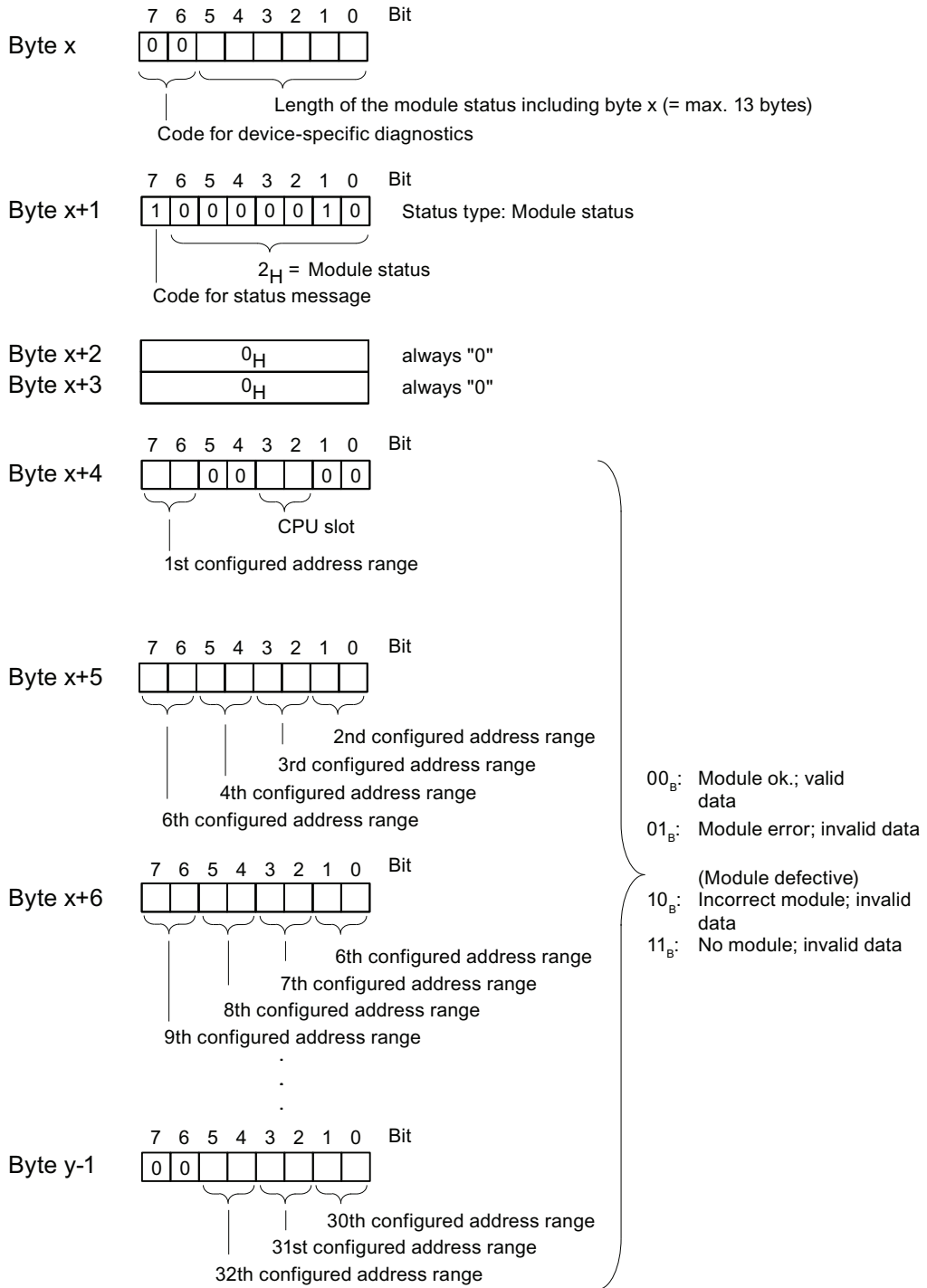
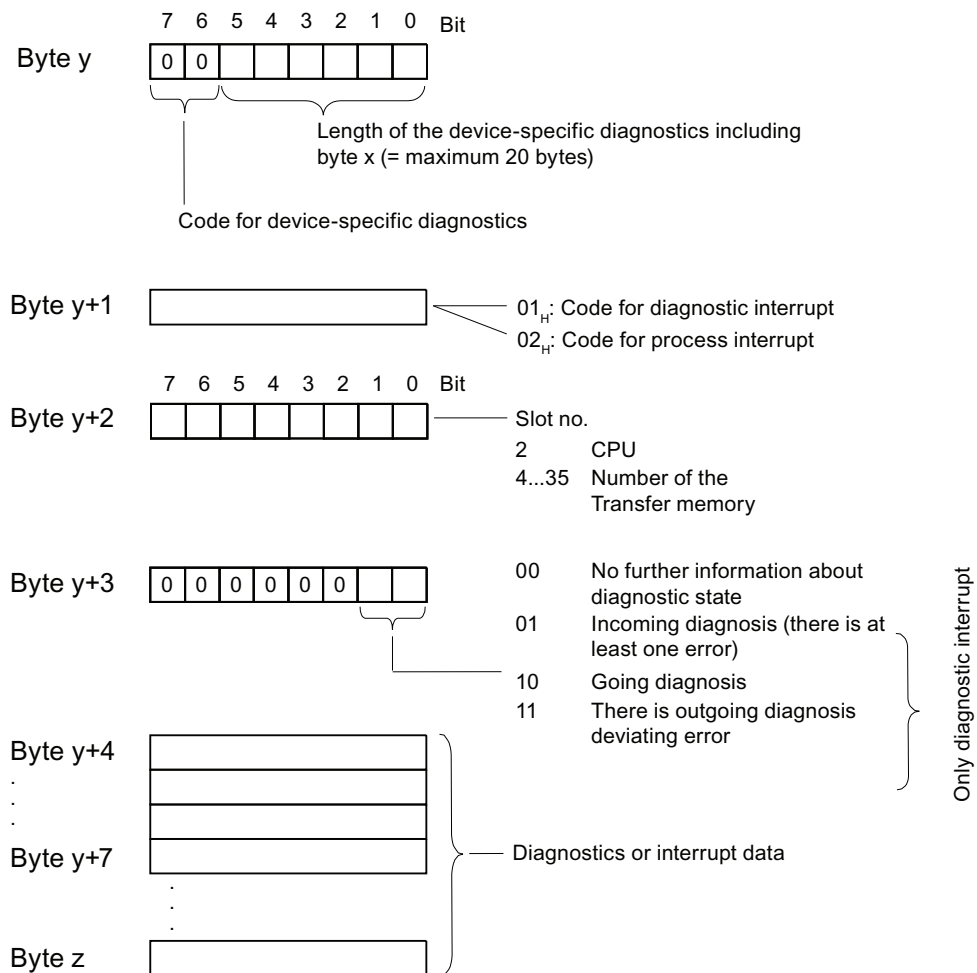

Figure 10-6 Structure of the module status for CPU 31xC

Structure of the interrupt status

The interrupt status of module diagnostics provides details on a DP slave. Device-related diagnostics starts at byte y and has a maximum length of 20 bytes.

The following figure describes the structure and content of the bytes for a configured address range of transfer memory.



Example for Byte y+2:
 CPU: =02_H
 1st address range: =04_H
 2nd address range: =05_H
 etc.

Figure 10-7 Device-specific diagnostics

Structure of the interrupt data for a process interrupt (from byte y+4)

During a hardware interrupt (in byte y+1, code 02_H stands for hardware interrupt), as of byte y+4, the four bytes of interrupt information which you transferred in the I-slave using SFC 7 "DP_PRAL" or SFB 75 "SALRM" during generation of the hardware interrupt for the master are transferred.

Structure of the interrupt data when a diagnostic interrupt is generated in response to an operating status change by the intelligent slave (after byte y+4)

Byte y+1 contains the code for a diagnostic interrupt (01_H). The diagnostic data contains the 16 bytes of status information from the CPU. The figure below shows the allocation of the first four bytes of diagnostic data. The next 12 bytes are always 0.

The data in these bytes correspond to the contents of data record 0 of diagnostic data in **STEP 7 (in this case, not all bits are used)**.

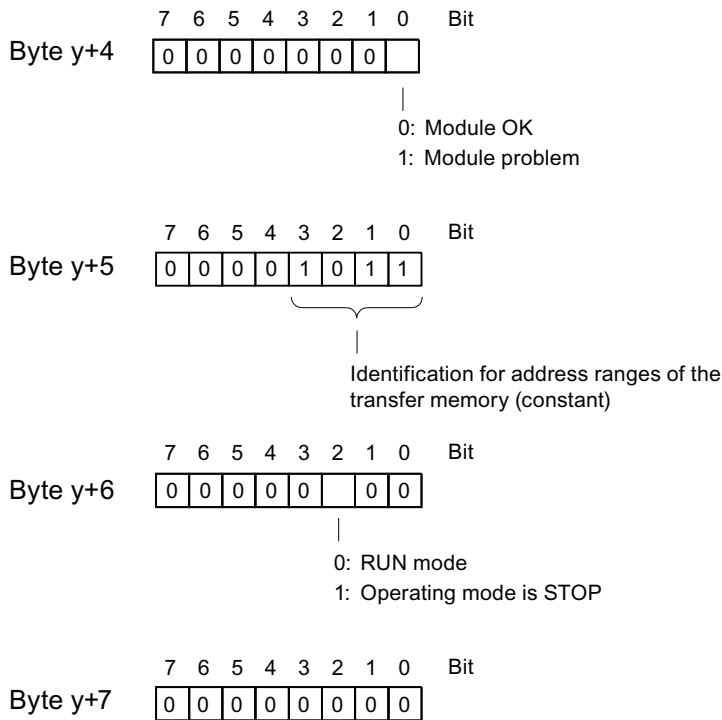

Note: Byte y+8 to Byte y+19 are always 0.

Figure 10-8 Bytes y+4 to y+7 for a diagnostic interrupt (operating status change by intelligent slave)

Structure of the interrupt data when a diagnostic interrupt is generated by SFB 75 on the I-slave (as of byte y+4)

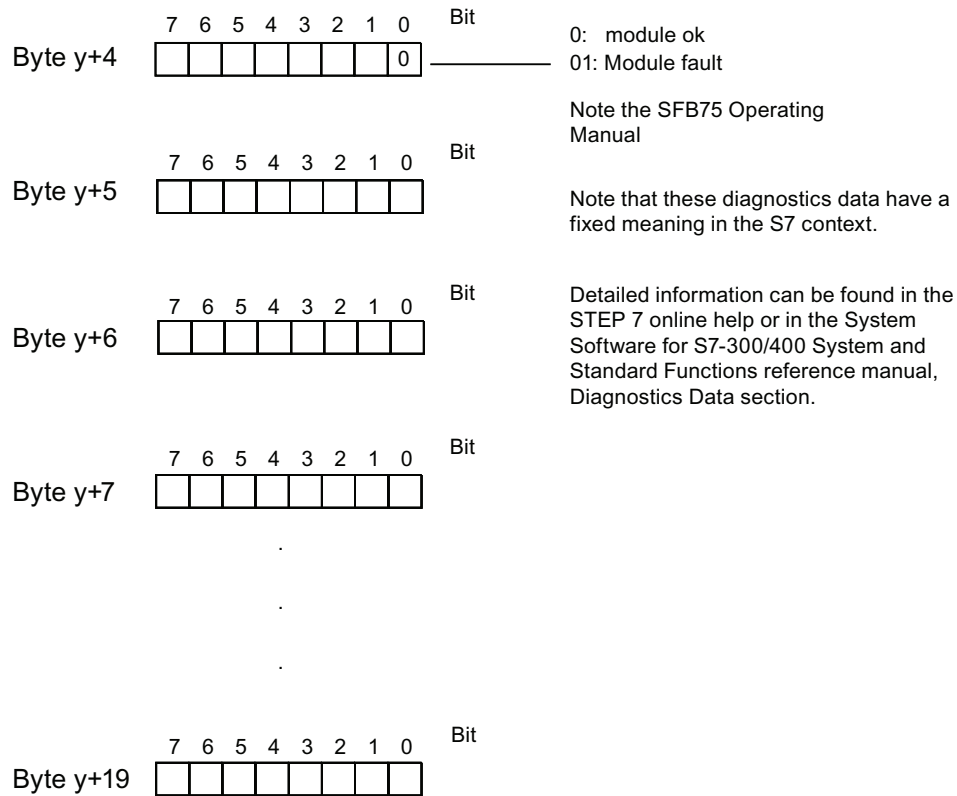

Figure 10-9 Bytes y+4 to y+19 for the diagnostics interrupt (SFB75)

10.10 Diagnostics of PROFINET CPUs

10.10.1 Diagnostics options of PROFINET IO

Diagnostics Concept

PROFINET IO supports you with an integrated diagnostics concept. The diagnostics concept of PROFINET IO is similar to that of PROFIBUS DP.

The diagnostics functions allow you

- to react to an error (event-related diagnostics, evaluation of interrupts) or
- to check the current status of the AS (status-related diagnostics).

Overview of diagnostics information

You have three options of obtaining diagnostics information:

1. Diagnostics using status LEDs

Diagnostics option	Benefits	For detailed information refer ...
LEDs on a PROFINET interface	The LED displays indicate: <ul style="list-style-type: none"> • whether data are being sent or received • communication error. 	this manual, chapter: Status and Error Indicators: CPUs with PROFINET interface for the S7-300

2. Diagnostics using the STEP 7 and NCM PC configuration and engineering tool

Diagnostics option	Benefits	For detailed information refer ...
Online diagnostics using a PG/PC/HMI	This allows you to evaluate the current status of your automation system.	the System Manual: PROFINET System Description, chapter: Support by STEP 7/NCM PC
Reporting system errors	Diagnostic information is output in plain text format to the PC / HMI.	the System Manual: PROFINET System Description, chapter: Support by STEP 7/NCM PC
Network diagnostics	The SNMP protocol allows you to determine the network infrastructure.	this manual, chapter: Network infrastructure diagnostics (SNMP)

3. Diagnostics in the STEP 7 user program

Diagnostics option	Benefits	For detailed information refer ...
Reading system status lists (SSLs)	The SSLs will help you to track down an error.	the System Manual: PROFINET System Description, chapter: Evaluation of Diagnostics in the User Program Reference manual: System software for S7-300/400 System and Standard Functions
Reading diagnostics data records	You can obtain detailed information about the type and source of faults by reading the diagnostic data records.	the System Manual: PROFINET System Description, chapter: Evaluation of Diagnostics in the User Program
Diagnostic interrupt	Can be used to evaluate diagnostics data in the user program.	the System Manual: PROFINET System Description, chapter: Evaluation of Diagnostics in the User Program

Evaluation of diagnostics information

PROFINET IO supports a vendor-independent structure of data records with diagnostics information. Diagnostics information is only generated for faulty channels.

The SSLs, SFB54 and SFB52 were enhanced to include information about the status of the PROFINET IO systems and the diagnostics information for an S7 user program:

- To read module status information of the PROFINET IO system, use SFC 51 (read system status lists) to read the information from SSL 0x0X96, for example.
- Call SFB52 (read data record) to read status-related diagnostics data records directly from a faulty module.
 - Status-related diagnostic data is error information, for example.
- Call SFB54 (read additional interrupt info) in the corresponding error OB to read event-related diagnostics data records from a module.
 - Event-related diagnostic data is interrupt information of the error OBs, for example.

Additional Information

Additional information about diagnostics and diagnostics data, on the structure of diagnostics data records and on SSLs for PROFINET is available in:

- the *From PROFIBUS DP to PROFINET IO Programming Manual*
- the *PROFINET System Description System Manual*
- the *System Software for S7-300/400, System and Standard Functions Reference Manual*
- in the *STEP 7 Online Help*

10.10.2 Maintenance

Enhanced maintenance concept

PROFINET devices support the comprehensive diagnostics and maintenance concept according to the IEC standard 61158-6-10.

In addition to "ok" and "faulty" information, the PROFINET components can also display information for preventive maintenance when operating with STEP 7 V5.4 Servicepack 1 or higher.

Preventive maintenance is displayed, for example, if the attenuation of a fiber-optic cable deteriorates.

Maintenance information

Maintenance information returns maintenance priorities. The concept distinguishes between maintenance information based on two levels:

Maintenance information	Symbol in STEP 7	Status of the MAINT LED	Example
Maintenance required (maintenance required): Maintenance recommended	green wrench	Off	The attenuation on a fiber-optic conductor is becoming too high. Although operation is still possible, the transmission link may fail completely in the near future.
Maintenance request (maintenance demanded): Maintenance required	yellow wrench	Yellow	Failure of the synchronization master in a synchronization domain for the IRT operation of a PNIO system.

Additional Information

Additional information is available in:

- the *From PROFIBUS DP to PROFINET IO Programming Manual*
- *PROFINET System Description system manual*
- *CPU 31xC and CPU 31x, Manual, Technical Data*, chapter Webserver
- in the *STEP 7 Online Help*

See also

Diagnostics options of PROFINET IO (Page 247)

General technical specifications

11.1 Standards and certifications

Introduction

Contents of general technical specifications:

- standards and test values satisfied by modules of the S7-300 automation system
- test criteria of S7-300 modules.

Note

Information about the nameplate

You will find the current identifiers and approvals on the rating plate of the respective product.

Safety information

 WARNING
--

Personal injury and damage to property may occur.

In potentially explosive environments, there is a risk of personal injury and damage to property if you remove S7-300 connectors in runtime.

In potentially explosive environments, always isolate the S7-300 before you remove any connectors.

 WARNING
--

Explosion hazard

If you replace components, compliance with Class I, DIV. 2 could be compromised.

 WARNING
--

This device is only appropriate for use in Class I, Div. 2, Group A, B, C, D, or in non-hazardous areas.

Test logos and their meaning

The section below describes the test logos attached to the module and explains their meaning.

CE Label



The S7-300 automation system satisfies requirements and safety-related objectives according to EC Directives listed below, and conforms with the harmonized European standards (EN) for programmable controllers announced in the Official Journals of the European Community:

- 2006/95/EC "Electrical Equipment Designed for Use within Certain Voltage Limits" (Low-Voltage Directive)
- 2004/108/EC "Electromagnetic Compatibility" (EMC Directive)
- 94/9/EC "Equipment and protective systems intended for use in potentially explosive atmospheres" (Explosion Protection Directive)

The EC declaration of conformity is held on file available to competent authorities at:

Siemens AG
Industry Sector
I IA AS R&D DH A
P.O. Box 1963
D-92209 Amberg

These files are also available for download on the Customer Support Internet pages, keyword "Declaration of Conformity".

UL approval



Underwriters Laboratories Inc., complying with

- UL 508 (Industrial Control Equipment)

CSA approval



Canadian Standards Association to

- C22.2 No. 142 (Process Control Equipment)

or

cULus approval



Underwriters Laboratories Inc., complying with

- UL 508 (Industrial Control Equipment)
- CSA C22.2 No. 142 (Process Control Equipment)

or

cULus HAZ. LOC approval



Underwriters Laboratories Inc., complying with

- UL 508 (Industrial Control Equipment)
- CSA C22.2 No. 142 (Process Control Equipment)
- UL 1604 (Hazardous Location)
- CSA C22.2 No. 213 (Hazardous Location)

APPROVED for use in
Class I, Division 2, Group A, B, C, D Tx;
Class I, Zone 2, Group IIC Tx

FM approval



Factory Mutual Research (FM) to
Approval Standard Class Number 3611, 3600, 3810
APPROVED for use in Class I, Division 2, Group A, B, C, D Tx;
Class I, Zone 2, Group IIC Tx

ATEX approval



In accordance with EN 60079-15 (Electrical Apparatus for Potentially Explosive Atmospheres; Type of Protection "n") and EN 60079-0 (Electrical apparatus for potentially explosive gas atmospheres - Part 0: General Requirements)



II 3 G Ex nA II T4..T6

WARNING

Personal injury and damage to property may occur.

In potentially explosive environments, there is a risk of personal injury and damage to property if you remove S7-300 connectors in runtime.

In potentially explosive environments, always isolate the S7-300 before you remove any connectors.

Tick mark for Australia and New Zealand



The S7-300 automation system meets requirements of standards to AS/NZS CISPR 16.

Note

The UL/CSA or cULus approvals for your product are specified by the identifiers on the rating plate.

IEC 61131

The S7-300 automation system satisfies requirements and criteria to IEC 61131-2 (Programmable Controllers, Part 2: Equipment requirements and tests).

Marine approval

Classification societies:

- ABS (American Bureau of Shipping)
- BV (Bureau Veritas)
- DNV (Det Norske Veritas)
- GL (Germanischer Lloyd)
- LRS (Lloyds Register of Shipping)
- Class NK (Nippon Kaiji Kyokai)

Use in industrial environments

SIMATIC products are designed for industrial applications.

Table 11- 1 Use in industrial environments

Field of application	Noise emission requirements	Noise immunity requirements
Industry	EN 61000-6-4: 2007	EN 61000-6-2: 2005

Use in residential areas

Note

The S7-300 is intended for use in industrial environments and can cause interference on radio/television reception if operated in residential areas.

To operate an S7-300 in a residential area, its RF emission must comply with Limit Value Class B to EN 55011.

Suitable measures for achieving RF interference level Class B include, for example:

- S7-300 installation in grounded switch cabinets / cubicles
- Use of noise filters in the supply lines

11.2 Electromagnetic compatibility

Definition

Electromagnetic compatibility (EMC) is the ability of an electrical installation to function satisfactorily in its electromagnetic environment without interfering with that environment. The S7-300 modules also satisfy requirements of EMC legislation for the European domestic market. Compliance of the S7-300 system with specifications and directives on electric design is prerequisite.

Pulse-shaped disturbance

The table below shows the electromagnetic compatibility of S7 modules in areas subject to pulse-shaped interference.

Pulse-shaped disturbance	Test voltage	corresponds with degree of severity
Electrostatic discharge according to IEC 61000-4-2.	Air discharge: ± 8 kV	3
	Contact discharge: ± 4 kV	2
Bursts (fast transient interference in accordance with IEC 61000-4-4)	2 kV (power supply lines)	3
	2 kV (signal lines > 3 m)	3
	1 kV (signal lines < 3 m)	
High-energy single pulse (surge) to IEC 61000-4-5 External protective circuit required (see Lightning and overvoltage protection (Page 278))		3
• asymmetric coupling	2 kV (power supply lines) DC with protective elements 2 kV (signal / data line only > 3 m), with protective elements as required	
• symmetric coupling	1 kV (power supply lines) DC with protective elements 1 kV (signal / data line only > 3 m), with protective elements as required	

Additional measures

When connecting an S7-300 system to the public network, always ensure compliance with Limit Value Class B to EN 55022.

Sinusoidal disturbance

The table below shows the electromagnetic compatibility of the S7-300 modules in areas subject to sinusoidal interference.

- RF radiation

RF radiation to IEC 61000-4-3 Electromagnetic RF field, amplitude-modulated		corresponds with degree of severity
80 to 1000 MHz; 1.4 to 2 GHz	2.0 GHz to 2.7 GHz	3, 2, 1
10 V/m	1 V/m	
80 % AM (1 kHz)		

- RF coupling

RF coupling to IEC 61000-4-6		corresponds with degree of severity
0.15 to 80 MHz		3
10 V _{rms} unmodulated		
80 % AM (1 kHz)		
150 Ω source impedance		

Emission of radio interference

Electromagnetic interference emission to EN 55016: Limit value class A (measured at a distance of 10 m).

Frequency	Emitted interference
30 MHz to 230 MHz	< 40 dB (μV/m)Q
230 MHz to 1000 MHz	< 47 dB (μV/m)Q

Noise emission via AC mains to EN 55016: Limit value class A, Group 1.

Frequency	Emitted interference
0.15 to 0.5 MHz	< 79 dB (μV/m)Q
	< 66 dB (μV/m)M
0.5 MHz to 5 MHz	< 73 dB (μV/m)Q
	< 60 dB (μV/m)M
5 MHz to 30 MHz	< 73 dB (μV/m)Q
	< 60 dB (μV/m)M

11.3 Transportation and storage conditions for modules

Introduction

The shipping and storage conditions of S7-300 modules surpass requirements to IEC 61131-2. The data below apply to modules shipped or put on shelf in their original packing.

The modules are compliant with climatic conditions to IEC 60721-3-3, Class 3K7 (storage), and with IEC 60721-3-2, Class 2K4 (shipping.)

Mechanical conditions are compliant with IEC 60721-3-2, Class 2M2.

Shipping and storage conditions for modules

Type of condition	Permissible range
Free fall (in shipping package)	≤ 1 m
Temperature	From -40 °C to +70 °C
Barometric pressure	1080 hPa to 660 hPa (corresponds with an altitude of -1000 m to 3500 m)
Relative humidity	10% to 95%, no condensation
Sinusoidal oscillation to IEC 60068-2-6	5 - 9 Hz: 3.5 mm 9 - 150 Hz: 9.8 m/s ²
Shock to IEC 60068-2-29	250 m/s ² , 6 ms, 1000 shocks

11.4 Mechanical and climatic environmental conditions for S7-300 operation

Operating conditions

S7-300 systems are designed for stationary use in weather-proof locations. The operating conditions surpass requirements to DIN IEC 60721-3-3.

- Class 3M3 (mechanical requirements)
- Class 3K3 (climatic requirements)

Use with additional measures

The S7-300 may not be used under the conditions outlined below without taking additional measures:

- At locations with a high degree of ionizing radiation
- In aggressive environments caused, for example, by
 - The development of dust
 - Corrosive vapors or gases
 - Strong electric or magnetic fields
- In installations requiring special monitoring, for example
 - Elevators
 - Electrical plants in potentially hazardous areas

An additional measure could be an installation of the S7-300 in a cabinet or housing.

Mechanical environmental conditions

The table below shows the mechanical environmental conditions in the form of sinusoidal oscillations.

Frequency band	Continuous	Infrequently
$10 \leq f \leq 58$ Hz	0,0375 mm amplitude	0.75 mm amplitude
$58 \leq f \leq 150$ Hz	0,5 g constant acceleration	1 g constant acceleration

Reducing vibrations

If your S7-300 modules are exposed to severe shock or vibration, take appropriate measures to reduce acceleration or the amplitude.

We recommend the installation of the S7-300 on damping materials (for example, rubber-bonded-to-metal mounting.)

11.4 Mechanical and climatic environmental conditions for S7-300 operation

Test of mechanical environmental conditions

The table below provides important information with respect to the type and scope of the test of ambient mechanical conditions.

Condition tested	Test Standard	Comment
Vibration	Vibration test to IEC 60068-2-6 (sinusoidal)	Type of oscillation: Frequency sweeps with a rate of change of 1 octave/minute. 5 Hz ≤ f ≤ 9 Hz, 3.5 mm constant amplitude 9 Hz ≤ f ≤ 150 Hz, 1 g constant acceleration Duration of oscillation: 10 frequency sweeps per axis at each of three vertically aligned axes
Shock	Shock, tested to IEC 60068-2-27	Type of shock: Half-sine Shock intensity: 15 g peak value, 11 ms duration Direction of shock: 3 shocks in each direction (+/-) at each of three vertically aligned axes

Climatic environmental conditions

The S7-300 may be operated on following environmental conditions:

Environmental conditions	Permissible range	Comments
Temperature: horizontal mounting position: vertical mounting position:	0°C to 60 °C 0°C to 40 °C	-
Relative humidity	from 10 to 95%	No condensation, corresponds to relative humidity (RH) Class 2 to IEC 61131, Part 2
Barometric pressure	1080 hPa to 795 hPa	Corresponds with an altitude of -1000 m to 2000 m
Concentration of pollutants	SO ₂ : < 0.5 ppm; RH < 60 %, no condensation H ₂ S: < 0.1 ppm; RH < 60 %, no condensation	Test: 10 ppm; 4 days Test: 1 ppm; 4 days
	ISA-S71.04 severity level G1; G2; G3	-

11.5 Specification of dielectric tests, protection class, degree of protection, and rated voltage of S7-300

Test voltage

Proof of dielectric strength must be provided in the type test at a test voltage to IEC 61131-2:

Circuits with rated voltage V_n to other circuits or ground.	Test voltage
< 50 V	500 VDC
< 150 V	2500 V DC
< 250 V	4000 V DC

Protection class

Protection class I to IEC 60536, i.e., a protective conductor must be connected to the mounting rail!

Protection against the ingress of foreign matter and water

- Degree of protection IP 20 to IEC 60529, i.e., protection against contact with standard probes.

No protection against the ingress of water.

11.6 Rated voltages of S7-300

Rated operating voltages

The S7-300 modules operate at different rated voltages. The table shows the rated voltages and corresponding tolerances.

Rated voltages	Tolerance
24 V DC	19.2 V DC to 28.8 V DC
120 VAC	93 VAC to 132 VAC
230 VAC	187 VAC to 264 VAC

Appendix

A.1 General rules and regulations for S7-300 operation

Introduction

Seeing that an S7-300 can be used in many different ways, we can only describe the basic rules for the electrical installation in this document.

 WARNING
Always observe these basic rules for electrical installation in order to achieve a fully functional S7-300 system.

EMERGENCY-OFF equipment

EMERGENCY-OFF equipment to IEC 204 (corresponds to VDE 113) must remain effective in all operating modes of the plant or system.

System startup after specific events

The table below shows what you have to observe when restarting a plant after specific events.

Table A- 1 System startup after specific events

If there is...	then ...
Restart following a voltage dip or power failure,	dangerous operating states must be excluded. If necessary, force EMERGENCY-OFF.
Startup after releasing the EMERGENCY OFF device,	uncontrolled or undefined startup operations must be excluded.

Mains voltage

The table below shows what you have to watch with respect to the mains voltage.

Table A- 2 Mains voltage

In the case of ...	the ...
Stationary systems or systems without all-pole mains disconnect switch	building installation must contain a mains disconnect switch or a fuse.
Load power supplies, power supply modules	set rated voltage range must correspond to local mains voltage.
All circuits of the S7-300	rated mains voltage fluctuation / deviation must lie within the permitted tolerance (refer to Technical Data of S7-300 modules).

24 VDC power supply

The table below shows what you must observe for the 24 VDC power supply.

Table A- 3 Protection against external electrical interference

In the case of ...	you need to observe ...	
Buildings	external lightning protection.	Install lightning protection (for example, lightning conductors)
24 VDC power supply cables, signal cables	internal lightning protection.	
24 VDC power supply	safe (electrical) extra-low voltage isolation	

Protection against external electrical interference

The table below shows how you must protect your system against electrical interference or faults.

Table A- 4 Protection against external electrical interference

In the case of ...	Make sure that ...
All plants or system in which the S7-300 is installed	the plant or system is connected to a protective conductor for the discharge of electromagnetic interference.
Supply / signal / bus cables	the cable routing and installation is correct.
Signal and bus cables	a cable/conductor break does not cause undefined plant or system states.

A.2 Protection against electromagnetic interference

A.2.1 Basic Points for EMC-compliant system installations

Definition: EMC

EMC (electromagnetic compatibility) describes the capability of electrical equipment to operate free of errors in a given electromagnetic environment, without being subject to external influence and without influencing external devices in any way.

Introduction

Although your S7-300 and its components are developed for an industrial environment and high electromagnetic compatibility, you should draw up an EMC installation plan before you install the controller taking into consideration all possible sources of interference.

Possible interferences

Electromagnetic interference can influence a PLC in various ways:

- Electromagnetic fields having a direct influence on the system
- Interference coupling caused by bus signals (PROFIBUS DP etc.)
- Interference coupling via the system wiring
- Interference influencing the system via the power supply and/or protective ground

The figure below shows the likely paths of electromagnetic interference.

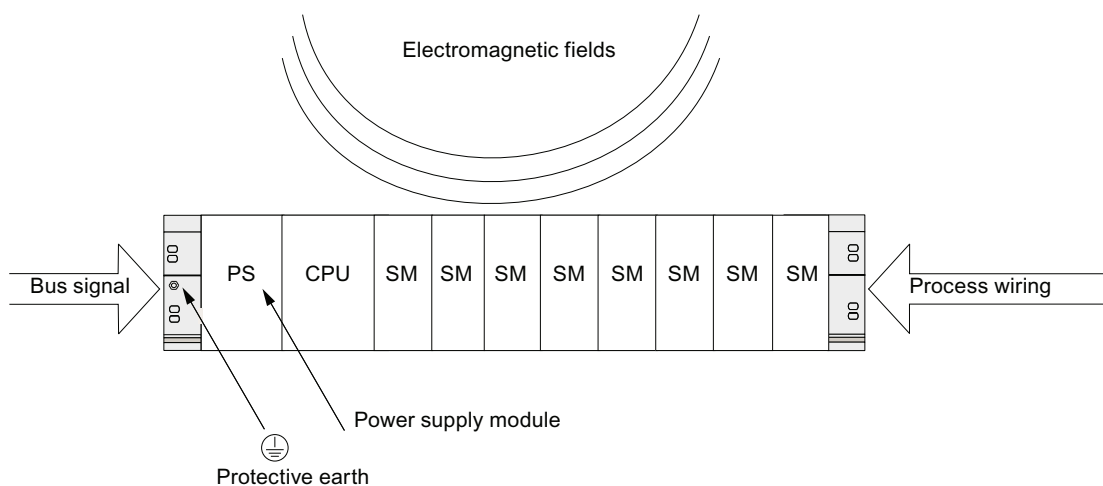

Coupling mechanisms

Depending on the emitting media (line or isolated) and the distance between the interference source and the device, four different coupling mechanisms can influence the PLC.

Table A- 5 Coupling mechanisms

Coupling mechanisms	Cause	Typical interference sources
Electrical coupling	Electrical or mechanical coupling always occurs when two circuits use one common cable.	<ul style="list-style-type: none"> • Clocked devices (influence on the network due to converters and third-party power supply modules) • Starting motors • Potential differences on component enclosures with common power supply • Static discharge
Capacitive coupling	Capacitive or electrical coupling occurs between conductors connected to different potentials. The coupling effect is proportional to voltage change over time.	<ul style="list-style-type: none"> • Interference coupling due to parallel routing of signal cables • Static discharge of the operator • Contactors
Inductive coupling	Inductive or magnetic coupling occurs between two current circuit loops. Current flow in magnetic fields induces interference voltages. The coupling effect is proportional to current change over time.	<ul style="list-style-type: none"> • Transformers, motors, arc welding devices • Power supply cables routed in parallelism • Switched cable current • High-frequency signal cable • Coils without suppression circuit
Radio frequency coupling	Radio frequency coupling occurs when an electromagnetic wave reaches a conductor system. This wave coupling induces currents and voltages.	<ul style="list-style-type: none"> • Neighboring transmitter (e.g. radio phones) • Sparking (spark plugs, collectors of electrical motors, welding devices)

A.2.2 Five basic rules for securing EMC

A.2.2.1 1. Basic rule for ensuring EMC

If you comply with these five basic rules ...

you can ensure EMC in many cases!

Rule 1: Large area grounding contact

When you install the automation equipment, make sure that the surfaces of inactive metal parts are properly bonded to chassis ground.

- Bond all passive metal parts to chassis ground, ensuring large area and low-impedance contact.
- When using screw connections on varnished or anodized metal parts, support contact with special contact washers or remove the protective insulating finish on the points of contact.
- Wherever possible, avoid the use of aluminum parts for ground bonding. Aluminum oxidizes very easily and is therefore less suitable for ground bonding.
- Create a central connection between chassis ground and the equipotential grounded/protective conductor system.

A.2.2.2 2. Basic rule for ensuring EMC

Rule 2: Proper cable routing

Always ensure proper cable routing when wiring your system.

- Sort your wiring system into groups (high-voltage/power supply/signal/data cables).
- Always route high-voltage, signal or data cables through separated ducts or in separate bundles.
- Install the signal and data cables as close as possible to grounded surfaces (e.g. supporting beams, metal rails, steel cabinet walls).

See also

Cable routing inside buildings (Page 275)

Outdoor routing of cables (Page 277)

A.2.2.3 3. Basic rule for ensuring EMC

Rule 3: Fixing the cable shielding

Ensure proper fixation of the cable shielding.

- Always use shielded data cable. Always connect both ends of the shielding to ground on a large area.
- Analog cables must always be shielded. For the transmission of low-amplitude signals it might prove to be more efficient to have only one side of the shielding connected to ground.
- Directly behind the cable entry in the cabinet or enclosure, terminate the shielding on a large area of the shielding/protective ground bar and fasten it with the help of a cable clamp. Then, route the cable to the module; however, do not connect the shielding once again to ground in this place.
- Connections between the shielding/protective ground conductor bar and the cabinet/enclosure must be of a low impedance.
- Always install shielded data cables in metal/metallized connector housings.

See also

Cable shielding (Page 272)

A.2.2.4 4. Basic rule for ensuring EMC

Rule 4: Special EMC measures

Take special EMC measures for particular applications.

- Connect anti-surge elements to all inductive devices not controlled by S7-300 modules.
- For cabinet or cubicle lighting in the immediate range of your controller, use incandescent lamps or interference suppressed fluorescent lamps.

See also

How to protect digital output modules against overvoltages caused by inductance (Page 290)

A.2.2.5 5. Basic rule for ensuring EMC

Rule 5: Homogeneous reference potential

Create a homogeneous reference potential and ground electrical equipment whenever possible (refer to the section on Equipotential bonding).

- Route your equipotential conductors over a wide area if potential differences exist or are expected between your system components.
- Make sure you carefully direct your grounding measures. Grounding measures protect the controller and its functions.
- Form a star circuit to connect the equipment in your system and the cabinets containing central/expansion units to the grounding/protective conductor system. This prevents the formation of ground loops.

See also

Equipotential bonding (Page 273)

A.2.3 EMC-compliant installation of automation systems

Introduction

Quite often it is the case that interference suppression measures are not taken until corruption of user signals is detected after the controller is actually in operation.

Frequently, the causes of such interference are found in inadequate reference potentials as a result of faulty installation. This section shows you how to avoid such errors.

Inactive metal parts

Inactive parts are referred to as electrically conductive elements, separated from active elements by a basic insulating and only subject to electrical potential if an error occurs.

Installation and ground bonding of inactive metal parts

Bond all inactive metal parts to a large-surface ground when you install the S7-300. Proper ground bonding ensures a homogeneous reference potential for the controller and reduces the effect of interference coupling.

The ground connection establishes an electrically conductive interconnection of all inactive parts. The sum of all interconnected inactive parts is referred to as chassis ground.

This chassis ground must never develop a hazardous potential even if a fault occurs. Therefore, chassis ground must be connected to the protective conductor using cables with an adequate conductor cross-section. To avoid ground loops, physically separate chassis ground elements (cabinets, parts of the building construction or machine) must be bonded to the protective conductor system in a star circuit.

Observe the following for ground connection:

- In the same way as with active elements, exercise meticulous care to interconnect inactive metal elements.
- Always make sure that you have a low-impedance interconnection between metal elements (e.g. large and highly conductive contact surface).
- The protective insulating finish on varnished or anodized metal elements must be pierced or removed. Use special contact washers or completely remove the finish on the point of contact.
- Protect your connecting elements against corrosion (e.g. with a suitable grease).
- Interconnect moving chassis ground elements (e.g. cabinet doors) with flexible ground straps. Always use short ground straps with a large surface (the surface is decisive for the diversion of high-frequency currents).

A.2.4 Examples of an EMC-compliant installation: Cabinet configuration

Cabinet configuration

The figure below shows a cabinet installation with the measures described above (bonding of inactive metal parts to chassis ground and connecting the cable shielding to ground). This sample applies only to grounded operation. Note the points in the figure when you install your system.

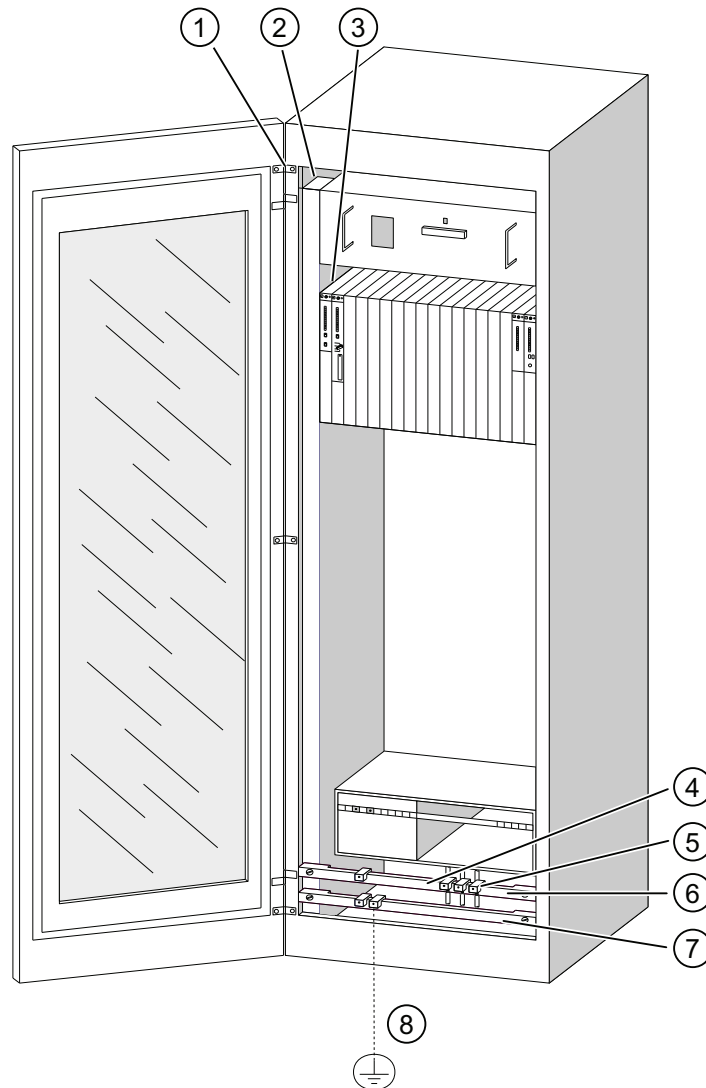

Figure A-1 Example of an EMC compatible cabinet installation

Key to installation

The numbers in the following list refer to the numbers in the figure above.

Number	Identifier	Explanation
①	Ground straps	If no large-surface metal-to-metal connections are available, you must either interconnect inactive metal parts (e.g. cabinet doors or mounting plates) or bond them to chassis ground using ground straps. Use short ground straps with a large surface.
②	Supporting bars	Interconnect the supporting bars on a large area to the cabinet walls (metal-to-metal connection).
③	Mounting the rail	The mounting bar and rack must be interconnected with large-area metal-to-metal connections.
④	Signal cables	Connect the shielding of signal cables on a large area of the protective conductor/additional shielding conductor bar and fasten them with cable clamps.
⑤	Cable clamp	The cable clamp must cover a large area of the shielding braid and ensure good contact.
⑥	Shielding conductor bar	Interconnect the shielding conductor bar on a large surface with the supporting bars (metal-to-metal connection). The cable shielding is terminated on the conductor bar.
⑦	Protective ground bar	Interconnect the protective conductor bar on a large surface with the supporting bars (metal-to-metal connection). Interconnect the grounding busbar with the protective ground system, using a separate cable (minimum cross-section 10 ²).
⑧	Cable to the protective ground system (equipotential ground)	Interconnect the cable on a large area with the protective ground system (equipotential ground).

A.2.5 Examples of an EMC-compliant installation: Wall mounting

Wall mounting

When operating your S7 in a low-noise environment that conform with permitted ambient conditions (see Appendix Ambient conditions), you can also mount your S7 in frames or to the wall.

Interference coupling must be diverted to large metal surfaces. Therefore, always mount standard profile/shielding/protective conductor rails on metal parts of the construction. Steel sheet panels reference potential surfaces have been found especially suitable for wall-mounting.

Provide a shielding conductor bar for connecting your cable shielding. This shielding conductor bar can also be used as protective ground bar.

Reference for ambient conditions

For information on ambient conditions, refer to the *S7-300 Automation System, Module data Reference Manual*.

Please note

- When mounting on varnished or anodized metal parts, use special contact washers or remove the insulating layers.
- Provide a large-surface and low-impedance metal-to-metal connection for fastening the shielding/protective protective ground bar.
- Always touch-protect live mains conductors.

The figure below shows an example of EMC compatible wall-mounting of an S7.

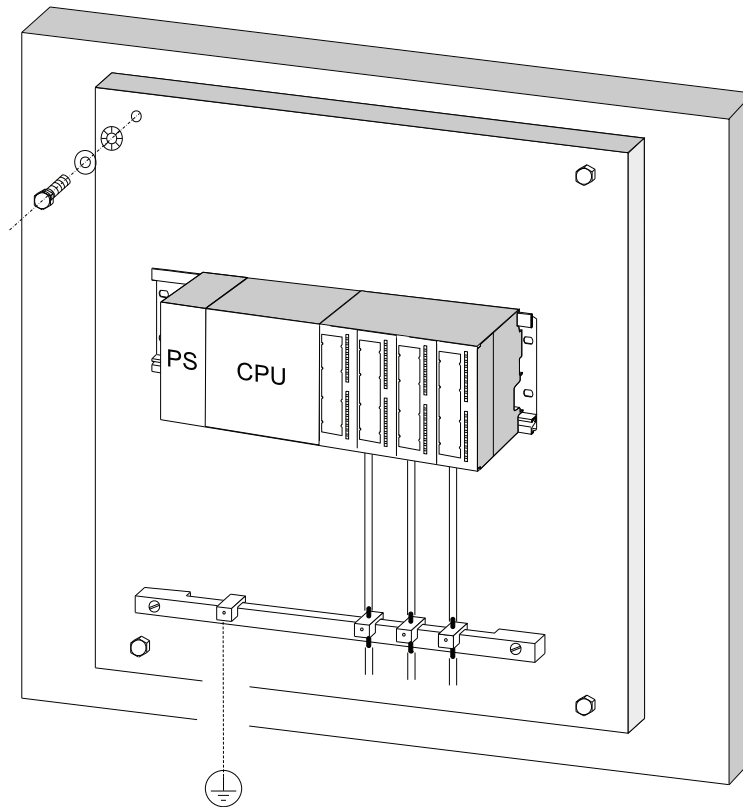

A.2.6 Cable shielding

Purpose of the shielding

A cable is shielded to attenuate the effects of magnetic, electrical and electromagnetic interference on the cable.

Operating principle

Interference currents on cable shielding is diverted to ground conductive interconnection between the shielding and the cabinet. To avoid interference as a result of these currents, it is imperative to provide a low-impedance connection to the protective conductor.

Suitable cables

Whenever possible, use cables equipped with a shielding braid. Shielding density should be at least 80 %. Avoid cables with film shielding, because the film can be easily damaged by tensile or pressure stress, thus reducing its shielding effect.

Handling of the shielding

Note the following points on handling the shielding:

- Always use metal clamps to mount shielding braid. The clamps must contact a large area of the shielding and provide appropriate contact force.
- Directly behind the cabinet's cable entry, terminate the shielding on a shielding bus. Then, route the cable to the module; however, do not connect the shielding once again to ground in this place.
- In installations outside of cabinets (e.g. for wall-mounting) you can also terminate the shielding on a cable duct.

The figure below shows some options for mounting shielded cables, using cable clamps.

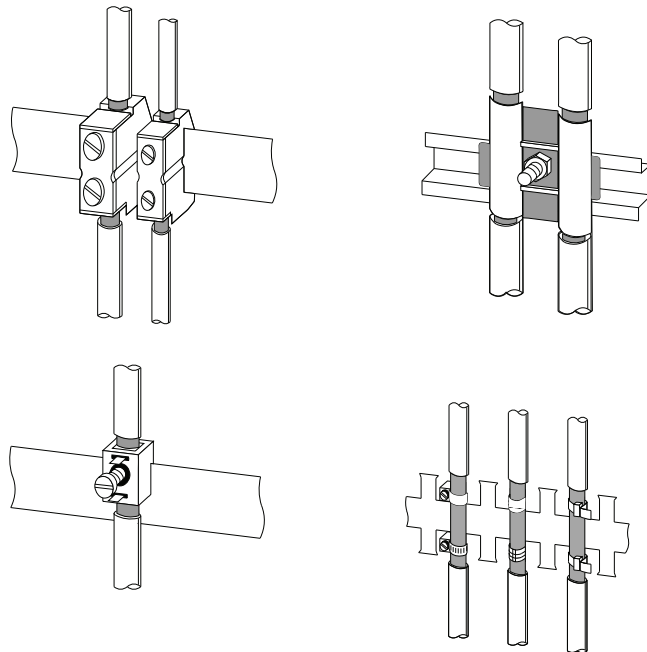

See also

Terminating shielded cables on the shield connection element (Page 121)

A.2.7 Equipotential bonding

Potential differences

Potential differences can occur between separate system elements. This can result in high equipotential currents, e.g. if the cable shielding is terminated at both ends and grounded to different system components.

The cause of potential difference can be differences in the power supplies.

WARNING

Cable shielding is not suitable for equipotential bonding. Always use the prescribed cables (for example, with a cross-section of 16 mm²). When installing MPI/DP networks, make sure that you provide a sufficient conductor cross-section. Otherwise, interface hardware might be damaged or even destroyed.

Equipotential bonding conductor

To reduce potential differences and ensure proper functioning of your electronic equipment, you must install equipotential bonding conductors.

Note the following points on the use of equipotential bonding conductors:

- The lower the impedance of an equipotential bonding conductor, the more effective is equipotential bonding.
- When shielded signal cables interconnect two system components and the shielding is connected on both ends to ground/protective conductors, the impedance of the additional equipotential bonding conductor must not exceed 10 % of the shielding impedance.
- Determine the cross-section of your equipotential bonding conductor on the basis of the maximum equalizing current that will flow through it. The equipotential bonding conductor cross-section that has proven best in practice is 16 mm².
- Always use equipotential bonding conductors made of copper or galvanized steel. Always connect the cables on a large surface to the equipotential conductor bar/protective conductor and protect it against corrosion.
- Route your equipotential bonding conductor to minimize the area between the equipotential bonding conductor and signal lines as far as possible (see the figure below).

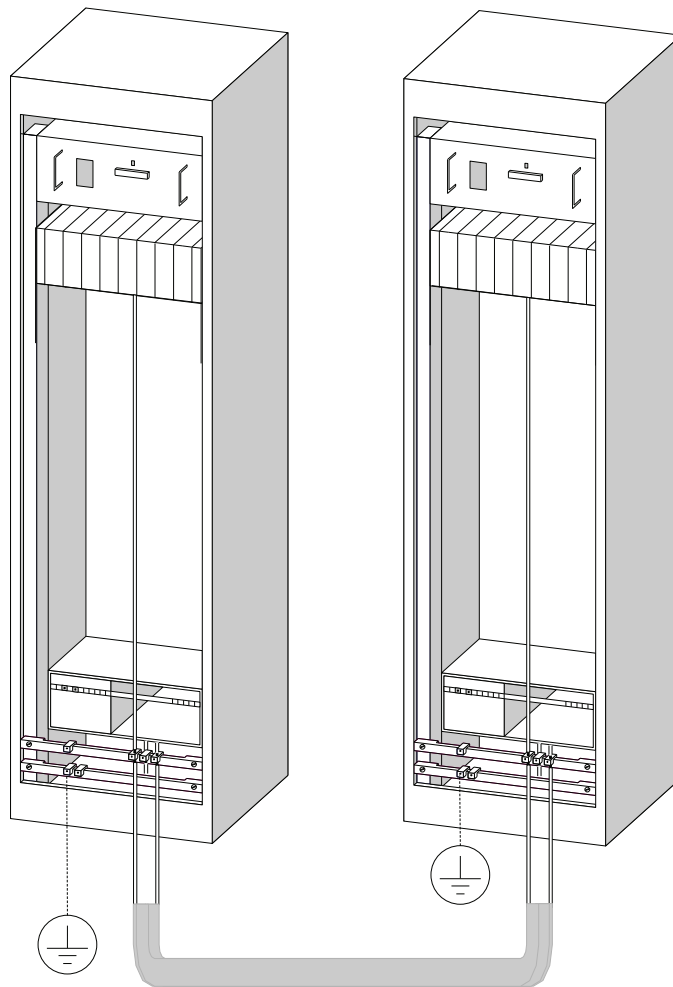

A.2.8 Cable routing inside buildings

Introduction

Inside buildings (inside and outside cabinets), clearances must be maintained between groups of different cables to achieve the necessary electromagnetic compatibility (EMC). The following table contains information on the general rules governing clearances to enable you to choose the correct cables.

How to read the table

To find out how to run two cables of different types, proceed as follows:

1. Look up the type of the first cable in column 1 (Cables for ...).
2. Look up the type of the second cable in the corresponding section in column 2 (and cables for ...).
3. Note the applicable directives in column 3 (Run ...).

Table A- 6 Cable routing inside buildings

Cables for ...	and cables for ...	Run ...
<ul style="list-style-type: none"> • Bus signals, shielded (for example, PROFIBUS, PROFINET) • Data signals, shielded (programming devices, operator panels, printers, counter inputs, etc.) • Analog signals, shielded • DC voltage (≤ 60 V), unshielded • Process signals (≤ 25 V), shielded • AC voltage (≤ 5 V), unshielded • Monitors (coaxial cable) 	<ul style="list-style-type: none"> • Bus signals, shielded (for example, PROFIBUS, PROFINET) • Data signals, shielded (programming devices, operator panels, printers, counter inputs, etc.) • Analog signals, shielded • DC voltage (≤ 60 V), unshielded • Process signals (≤ 25 V), shielded • AC voltage (≤ 25 V), unshielded • Monitors (coaxial cable) 	In common bundles or cable ducts
	<ul style="list-style-type: none"> • DC voltage (> 60 V and ≤ 400 V), unshielded • AC voltage (> 25 V and ≤ 400 V), unshielded 	In separate bundles or cable ducts (no minimum clearance necessary)
	<ul style="list-style-type: none"> • DC and AC voltage (> 400 V), unshielded 	<p>Inside cabinets: In separate bundles or cable ducts (no minimum clearance necessary)</p> <p>Outside cabinets: On separate cable racks with a clearance of at least 10 cm</p>

A.2 Protection against electromagnetic interference

Cables for ...	and cables for ...	Run ...
<ul style="list-style-type: none"> • DC voltage (> 60 V and ≤ 400 V), unshielded • AC voltage (> 25 V and ≤ 400 V), unshielded 	<ul style="list-style-type: none"> • Bus signals, shielded (for example, PROFIBUS, PROFINET) • Data signals, shielded (programming devices, operator panels, printers, counter inputs, etc.) • Analog signals, shielded • DC voltage (≤ 60 V), unshielded • Process signals (≤ 25 V), shielded • AC voltage (≤ 25 V), unshielded • Monitors (coaxial cable) 	<p>In separate bundles or cable ducts (no minimum clearance necessary)</p>
	<ul style="list-style-type: none"> • DC voltage (> 60 V and ≤ 400 V), unshielded • AC voltage (> 25 V and ≤ 400 V), unshielded 	<p>In common bundles or cable ducts</p>
	<ul style="list-style-type: none"> • DC and AC voltage (> 400 V), unshielded 	<p>Inside cabinets: In separate bundles or cable ducts (no minimum clearance necessary)</p> <p>Outside cabinets: On separate cable racks with a clearance of at least 10 cm</p>
<p>DC and AC voltage (> 400 V), unshielded</p>	<ul style="list-style-type: none"> • Bus signals, shielded (e.g. PROFIBUS, PROFINET) • Data signals, shielded (programming devices, operator panels, printers, counter inputs, etc.) • Analog signals, shielded • DC voltage (≤ 60 V), unshielded • Process signals (≤ 25 V), shielded • AC voltage (≤ 25 V), unshielded • Monitors (coaxial cable) 	<p>Inside cabinets: In separate bundles or cable ducts (no minimum clearance necessary)</p> <p>Outside cabinets: On separate cable racks with a clearance of at least 10 cm</p>
	<ul style="list-style-type: none"> • DC and AC voltage (> 400 V), unshielded 	<p>In common bundles or cable ducts</p>

A.2.9 Outdoor routing of cables

Rules for EMC-compliant cable routing

The same EMC-compliant rules apply both to indoor and outdoor routing of cables. The following also applies:

- Running cables on metal cable trays.
- Electrical connection of the joints of cable trays/ducts.
- Ground the cable carriers.
- If necessary, provide adequate equipotential bonding between connected devices.
- Take the necessary (internal and external) lightning protection and grounding measures in as far as they are applicable to your particular application.

Rules for lightning protection outside buildings

Run your cables either:

- in metal conduits grounded at both ends, or
- in concrete cable ducts with continuous end-to-end armoring.

Overvoltage protection equipment

An individual appraisal of the entire plant is necessary before any lightning protection measures are taken.

A.3 Lightning and surge voltage protection

A.3.1 Overview

Introduction

One of the most common causes of failure is overvoltage caused by:

- Atmospheric discharges
- Electrostatic discharges
- Switching overvoltages

The concepts or measures for protection from overvoltages is based on the lightning protection zone concept.

The rules to be complied with for the transitions between the individual lightning protection zones are presented here.

Note

This section can only provide you with the general guide on protecting the S7-300 from overvoltage.

Complete protection from overvoltage is only guaranteed if the entire system design is based on the lightning protection zone concept. Comprehensive consideration must be given to this when planning construction of facilities.

We therefore recommend that you contact your Siemens representative or a company specialized in lightning and overvoltage protection if you require more detailed information about overvoltage.

From now on, we refer to the overvoltage protection device using the normative terminology, that is, according to the degree of hazard expected (pulse shape 8/20 μ s or pulse shape 10/350 μ s), divided into surge arresters for pulse shape 8/20 μ s and lightning current arresters for pulse shape 10/350 μ s.

Additional references

The following information is based on the lightning protection zone concept described in the IEC standard 62305-4 - "Protection against LEMP".

A.3.2 Lightning protection zone concept

Principle of the lightning protection zone concept according to IEC 62305-4, DIN EN 62305-4, VDE 0185-305-4

The principle behind the lightning protection zone concept is the division of the volume to be protected from overvoltages (e.g. a control room) into lightning protection zones based on EMC considerations (see figure A-2).

The various lightning protection zones (LPZ: Lightning Protection Zone) are delimited spatially as follows and not necessarily by physical boundaries, such as walls, floors, etc.

Lightning protection zones (LPZ: Lightning Protection Zone)	
Outside areas of a building with risk of a direct strike	Lightning protection zone LPZ 0 _A
Outside areas of a building that are not at risk of a direct strike	Lightning protection zone LPZ 0 _B
Inside areas of a building that follow lightning protection zone 0 _B	Lightning protection zone LPZ 1
Inside areas of a building that normally represent separate EMC-reducing rooms and are in lightning protection zone 1	Lightning protection zone LPZ 2
Electrical equipment (with shielding properties) in lightning protection zone 2	Lightning protection zone LPZ 3

Effects of the Lightning Strike

Direct lightning strikes occur in lightning protection zone 0_A. Effects of the lightning strike are high-energy lightning currents and strong electromagnetic fields. Effects must be reduced from one lightning protection zone to the next through suitable lightning current or surge arresters/shielding measures.

Overvoltage

Electromagnetic fields of the lightning channel can be reduced with appropriate shielding measures. Overvoltages due to inductions can be reduced to a non-dangerous level starting in lightning protection zone 0_B using surge arresters.

Diagram of the lightning protection zones

The following schematic diagram shows the implementation of the lightning protection zone concept for a building with outside lightning protection.

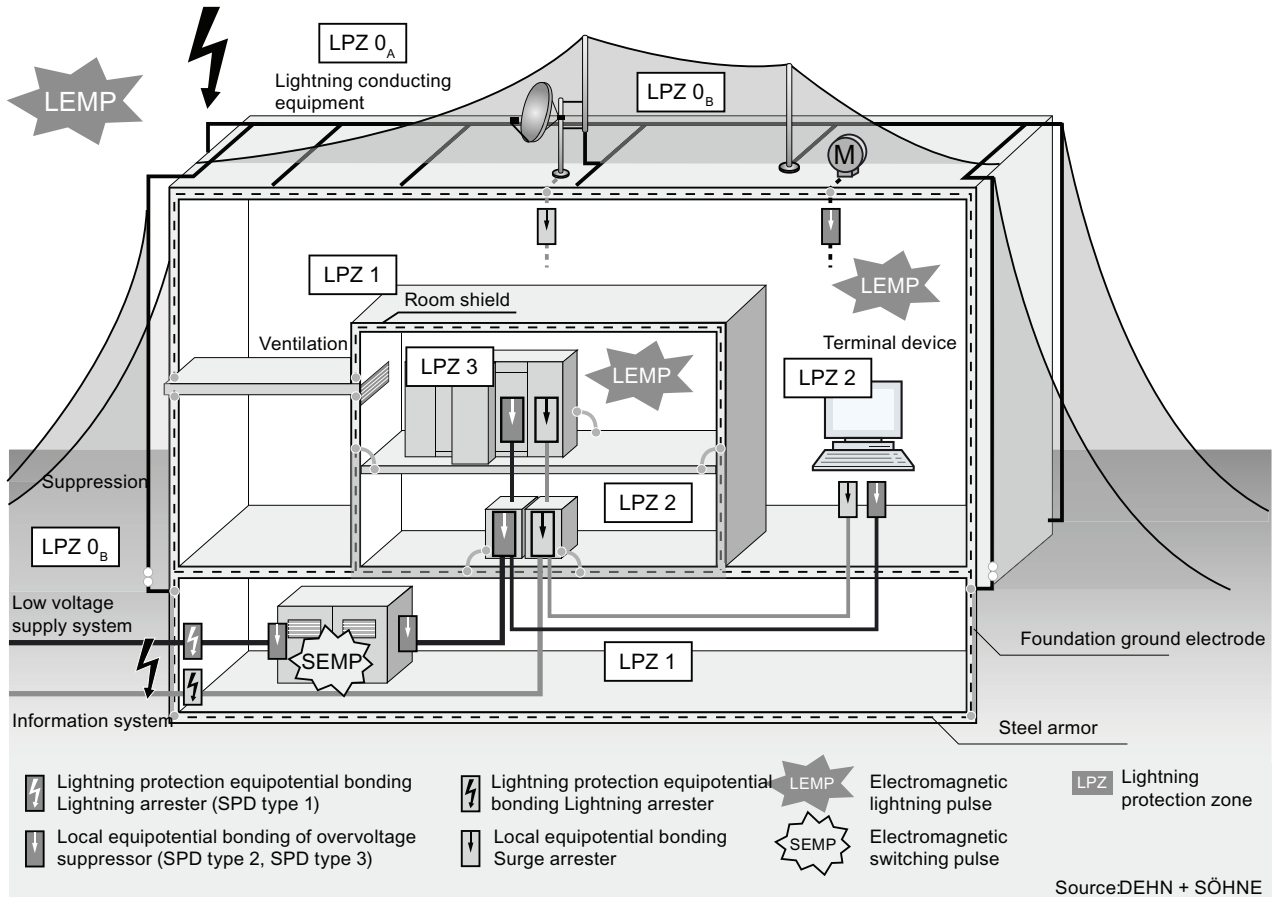

Figure A-2 Lightning protection zones of a building with outside lightning protection

Principle of interfaces between the lightning protection zones

Measures must be taken to reduce the peak current load and the magnetic fields at the interfaces between the lightning protection zones.

Each zone-penetrating metallic/electrical system must be incorporated into the equipotential bonding at the zone transition.

Note

Metal systems include ducts, structural parts, pipes (water, gas and heat), etc.

Electrical systems include power and IT cables and wires (e.g. line voltage, bus cable, ...).

A.3.3 Rules for the interface between the lightning protection zones 0 and 1

Rules for the interface 0_A to 1 (lightning protection equipotential bonding)

For lightning protection equipotential bonding at the interface of lightning protection zone 0_A to 1, the following applies:

- Use of lightning current suppressors prevents introduction of lightning partial currents into buildings.
- Creation of a local equipotential bonding at the transition of lightning protection zones, with incorporation of metal supply systems (pipes, air ducts, cable ducts, cable channels etc.).

Components for the lightning protection equipotential bonding

Table A- 7 Components for the lightning protection equipotential bonding

Seq. No.	Cables for ...	Connection at the interface 0 _A to 1 with:	Item number
1	3-phase TN-C system	DEHNventil® DV M TNC 255 DEHNventil® DV M TNC 255 FM *	951 300 951 305 *
2	3-phase TN-S system	DEHNventil® DV M TNS 255 DEHNventil® DV M TNS 255 FM *	951 400 951 405 *
3	3-phase TT system	DEHNventil® DV M TT 255 DEHNventil® DV M TT 255 FM *	951 310 951 315 *
4	AC TN-S system	DEHNventil® DV M TN 255 DEHNventil® DV M TN 255 FM *	951 200 951 205 *
5	AC TT system	DEHNventil® DV M TT 2P 255 DEHNventil® DV M TT 2P 255 FM *	951 110 951 115 *
6	Supply U _N = 24 VDC	BLITZDUCTOR® XT, basic unit BXT BAS BLITZDUCTOR® XT, module BXT ML2 B 180 (I _L = 1.2 A) (2-wire)	920 300 920 211
7	Supply U _N = 24 VDC	DEHNbloc® M, DB M 1 150 DEHNbloc® M, DB M 1 150 FM * (2 ea. required)	961 110 961 115 *
8	MPI bus cable, RS485, RS 232 (V.24)	BLITZDUCTOR® XT, basic unit BXT BAS BLITZDUCTOR® XT, Module BXT ML2 B 180 (2-wire)	920 300 920 211
9	Inputs/outputs of digital modules U _N = 24 VDC	BLITZDUCTOR® XT, basic unit BXT BAS BLITZDUCTOR® XT, Module BXT ML4 B 180 (I _L = 1.2 A) (4-wire)	920 300 920 310
10	Inputs/outputs of digital modules U _N = 230 VAC	DEHNbloc® M, DB M 1 255 DEHNbloc® M, DB M 1 255 * (2 ea. required)	961 120 961 125 *

Seq. No.	Cables for ...	Connection at the interface 0 _A to 1 with:	Item number
11	Inputs/outputs of analog modules (for example, 4-20 mA, 1-10 V)	BLITZDUCTOR [®] XT, basic unit BXT BAS BLITZDUCTOR [®] XT, module BXT ML4 B 180 (I _L = 1.2 A) (4-wire)	920 300 920 310
<p>* Version: With remote indication contact</p> <p>Components of the series BLITZDUCTOR[®] XT can be remotely monitored with the appropriate accessories. Additional information under (http://www.dehn.de)</p> <p>Direct order of components via: DEHN+SÖHNE GMBH+CO.KG. Hans-Dehn-Str. 1 D-92318 Neumarkt Tel. +49 (0)9181-906-730</p>			

Rules for the interface 0_B to 1 (strong electromagnetic coupling)

For overvoltage protection at the interface of lightning protection zone 0_B to 1, the following applies:

- Use of power cables with peak current-capable cable shields (e.g., NYCWY) or twisted-pair IT cables (for example, A2Y(K)Y).
- Laying cables and lines
 - In continuous, peak current-capable metal pipes that are grounded at both ends
 - In reinforced concrete channels in which the reinforcement is grounded at both ends
 - On closed metal cable racks that are grounded at the beginning and end
- Use of fiber-optic cables without a metal shield if such a transmission is intended
- Creation of a local equipotential bonding at the transition of lightning protection zones, with incorporation of metal supply systems (pipes, air ducts, cable ducts, cable channels etc.).

Additional measures

If the actions listed above cannot be performed, protection by means of surge arresters must be provided. The following table contains overvoltage suppressors that may be used to protect facilities.

Overvoltage protection of 24 VDC power supply

Always use the BLITZDUCTOR VT, type AD 24 V for the 24 VDC power supply of the S7-300. All other surge arrestors do not meet the tolerance range (19.2 - 28.8 V) of the S7-300.

General information on use of surge arresters

If, taking into account the tolerance range, the voltages that occur in the system exceed the specified maximum limits of the surge arresters used, surge arrestors of the next highest rated voltage series are to be used.

Components for the overvoltage protection

Table A- 8 Components for the overvoltage protection

Seq. No.	Cables for ...	Connection at the interface 0_B to 1 with:	Item number
1	3-phase TN-C system	DEHNguard® DG M TNC 275 DEHNguard® DG M TNC 275 FM *	952 300 952 305 *
2	3-phase TN-S system	DEHNguard® DG M TNS 275 DEHNguard® DG M TNS 275 FM *	952 400 952 405 *
3	3-phase TT system	DEHNguard® DG M TT 275 DEHNguard® DG M TT 275 FM *	952 310 952 315 *
4	AC TN-S system	DEHNguard® DG M TN 275 DEHNguard® DG M TN 275 FM *	952 200 952 205 *
5	AC TT system	DEHNguard® DG M TT 2P 275 DEHNguard® DG M TT 2P 275 FM *	952 110 952 115 *
6	Supply $U_N = 24$ VDC	BLITZDUCTOR® VT, BVT AD 24	918 402
7	MPI/DP RS 485 bus cable	BLITZDUCTOR® XT, basic unit BXT BAS BLITZDUCTOR® XT, Module BXT ML2 BD HFS 5	920 300 920 271
8	RS 232 (V.24) bus cable	BLITZDUCTOR® XT, basic unit BXT BAS BLITZDUCTOR® XT, Module BXT ML2 BE S 12	920 300 920 222
9	Industrial Ethernet	DEHNpatch DPA M CLE RJ45B 48	929 121
10	Inputs of digital modules $U_N = 24$ VDC	DEHNconnect RK, DCO RK ME 24 ($I_L = 0.5$ A)	919 921
11	Outputs of digital modules $U_N = 24$ VDC	DEHNconnect RK, DCO RK D 5 24 ($I_L = 10.0$ A)	919 986
12	Inputs/outputs of digital modules $U_N = 230$ VAC	DEHNguard® DG S 275 DEHNguard® DG S 275 FM * N-PE arrester in the TT system DEHNgap C S, DGP C S DEHNgap C S, DGP C S FM *	952 070 952 090 * 952 030 952 035 *
13	Inputs/outputs of analog modules (e.g. 4-20 mA, 1-10 V)	DEHNconnect RK, DCO RK ME 24 ($I_L = 0.5$ A)	919 921
<p>* Version: With remote indication contact</p> <p>Components of the series BLITZDUCTOR® XT can be remotely monitored with the appropriate accessories. Additional information under (http://www.dehn.de)</p> <p>Direct order of components via: DEHN+SÖHNE GMBH+CO.KG. Hans-Dehn-Str. 1 D-92318 Neumarkt Tel. +49 (0)9181-906-730</p>			

A.3.4 Rules for the interface between the lightning protection zones 1 and 2

Rules for the interface 1 to 2 (strong electromagnetic coupling)

For overvoltage protection at the interface 1 to 2, the following applies:

- Use of power cables with peak current-capable cable shields (e.g., NYCWY) or twisted-pair IT cables (for example, A2Y(K)Y).
- Laying cables and lines
 - In continuous, peak current-capable metal pipes that are grounded at both ends, or
 - In reinforced concrete channels in which the reinforcement is grounded at both ends, or
 - On closed metal cable racks that are grounded at the beginning and end
- Use of fiber-optic cables without a metal shield if such a transmission is intended
- Creation of a local equipotential bonding at the transition of lightning protection zones, with incorporation of metal supply systems (pipes, air ducts, cable ducts, cable channels etc.).

Additional measures

If the actions listed above cannot be performed, protection by means of surge arresters must be provided. The following table contains surge arresters that may be used to protect facilities.

Overvoltage protection of 24 VDC power supply

Always use the BLITZDUCTOR VT, type AD 24 V for the 24 VDC power supply of the S7-300. All other surge arresters do not meet the tolerance range (19.2 - 28.8 V) of the S7-300.

General information on use of surge arresters

If, taking into account the tolerance range, the voltages that occur in the system exceed the specified maximum limits of the surge arresters used, surge arresters of the next highest rated voltage series are to be used.

Components for the overvoltage protection

Table A-9 Components for the overvoltage protection

Seq. no.	Cables for ...	Connection at the interface 1 to 2 with:	Item number
1	3-phase TN-C system	DEHNguard® DG M TNC 275 DEHNguard® DG M TNC 275 FM *	952 300 952 305 *
2	3-phase TN-S system	DEHNguard® DG M TNS 275 DEHNguard® DG M TNS 275 FM *	952 400 952 405 *
3	3-phase TT system	DEHNguard® DG M TT 275 DEHNguard® DG M TT 275 FM *	952 310 952 315 *
4	AC TN-S system	DEHNguard® DG M TN 275 DEHNguard® DG M TN 275 FM *	952 200 952 205 *
5	AC TT system	DEHNguard® DG M TT 2P 275 DEHNguard® DG M TT 2P 275 FM *	952 110 952 115 *
6	Supply $U_N = 24$ VDC	BLITZDUCTOR® VT, BVT AD 24	918 402
7	MPI/DP RS 485 bus cable	BLITZDUCTOR® XT, basic unit BXT BAS BLITZDUCTOR® XT, Module BXT ML2 BD HFS 5	920 300 920 271
8	RS 232 (V.24) bus cable	BLITZDUCTOR® XT, basic unit BXT BAS BLITZDUCTOR® XT, Module BXT ML2 BE S 12	920 300 920 222
9	Industrial Ethernet	DEHNpatch DPA M CLE RJ45B 48	929 121
10	Inputs of digital modules $U_N = 24$ VDC	DEHNconnect RK, DCO RK ME 24 ($I_L = 0.5$ A)	919 921
11	Outputs of digital modules $U_N = 24$ VDC	DEHNconnect RK, DCO RK D 5 24 ($I_L = 10.0$ A)	919 986
12	Inputs/outputs of digital modules $U_N = 230$ VAC	DEHNguard® DG S 275 DEHNguard® DG S 275 FM * N-PE arrester in the TT system DEHNgap DGP C S DEHNgap DGP C S FM *	952 070 952 090 * 952 030 952 035 *
13	Inputs/outputs of analog modules (e.g. 4-20 mA, 1-10 V)	DEHNconnect RK, DCO RK ME 24 ($I_L = 0.5$ A)	919 921
<p>* Version: With remote indication contact</p> <p>Components of the series BLITZDUCTOR® XT can be remotely monitored with the appropriate accessories. Additional information under (http://www.dehn.de)</p> <p>Direct order of components via: DEHN+SÖHNE GMBH+CO.KG. Hans-Dehn-Str. 1 D-92318 Neumarkt Tel. +49 (0)9181-906-730</p>			

A.3.5 Rules for the interface between the lightning protection zones 2 and 3

Rules for the interface 2 to 3 (electromagnetic coupling)

For overvoltage protection at the interface 2 to 3, the following applies:

- Use of power cables with peak current-capable cable shields (e.g., NYCWY) or twisted-pair IT cables (for example, A2Y(K)Y).
- Laying cables and lines
 - In continuous, peak current-capable metal pipes that are grounded at both ends, or
 - In reinforced concrete channels in which the reinforcement is grounded at both ends, or
 - On closed metal cable racks that are grounded at the beginning and end
- Use of fiber-optic cables without a metal shield if such a transmission is intended
- Creation of a local equipotential bonding at the transition of lightning protection zones, with incorporation of metal supply systems (pipes, air ducts, cable ducts, cable channels etc.).

Additional measures

If the actions listed above cannot be performed, protection by means of surge arresters must be provided. The following table contains surge arresters that may be used to protect facilities.

Overvoltage protection of 24 VDC power supply

Always use the BLITZDUCTOR VT, type AD 24 V for the 24 VDC power supply of the S7-300. All other surge arrestors do not meet the tolerance range (19.2 - 28.8 V) of the S7-300.

General information on the use of surge arresters

If, taking into account the tolerance range, the voltages that occur in the system exceed the specified maximum limits of the surge arresters used, surge arrestors of the next highest rated voltage series are to be used.

Components for the overvoltage protection

Table A- 10 Components for the overvoltage protection

Seq. no.	Cables for ...	Connection at the interface 2 to 3 with:	Item number
1	3-phase TN-S, TT system	DEHNrail® DR M 4P 255 DEHNrail® DR M 4P 255 FM * (I _L = 25.0 A)	953 400 953 405 *
2	AC TN-S, TT system	DEHNrail® DR M 2P 255 DEHNrail® DR M 2P 255 FM * (I _L = 25.0 A)	953 200 953 205 *
3	Supply U _N = 24 VDC	BLITZDUCTOR® VT, BVT AD 24	918 402
4	MPI/DP RS 485 bus cable	BLITZDUCTOR® XT, basic unit BXT BAS BLITZDUCTOR® XT, module BXT ML2 BD HFS 5	920 300 920 271
5	RS 232 (V.24) bus cable	BLITZDUCTOR® XT, basic unit BXT BAS BLITZDUCTOR® XT, module BXT ML2 BE S 12	920 300 920 222
6	Industrial Ethernet	DEHNpatch DPA M CLE RJ45B 48	929 121
7	Inputs of digital modules U _N = 24 VDC	DEHNconnect RK, DCO RK ME 24 (I _L = 0.5 A)	919 921
8	Outputs of digital modules U _N = 24 VDC	DEHNconnect RK, DCO RK D 5 24 (I _L = 10.0 A)	919 986
9	Inputs/outputs of digital modules U _N = 230 VAC	DEHNguard® DG S 275 DEHNguard® DG S 275 FM * N-PE arrester in the TT system DEHNgap C S, DGP C S DEHNgap C S, DGP C S FM *	952070 952 090 * 952 030 952 035 *
10	Inputs/outputs of analog modules (e.g. 4-20 mA, 1-10 V)	DEHNconnect RK, DCO RK ME 24 (I _L = 0.5 A)	919 921
<p>* Version with remote indication contact</p> <p>Components of the series BLITZDUCTOR® XT can be remotely monitored with the appropriate accessories. Additional information under (http://www.dehn.de)</p> <p>Direct order of components via: DEHN+SÖHNE GMBH+CO.KG. Hans-Dehn-Str. 1 D-92318 Neumarkt Tel. +49 (0)9181-906-730</p>			

A.3.6 Example: Surge protection circuit for networked S7-300 CPUs

The figure shows the required measures for the protection of two networked S7-300 against lightning strikes and overvoltage.

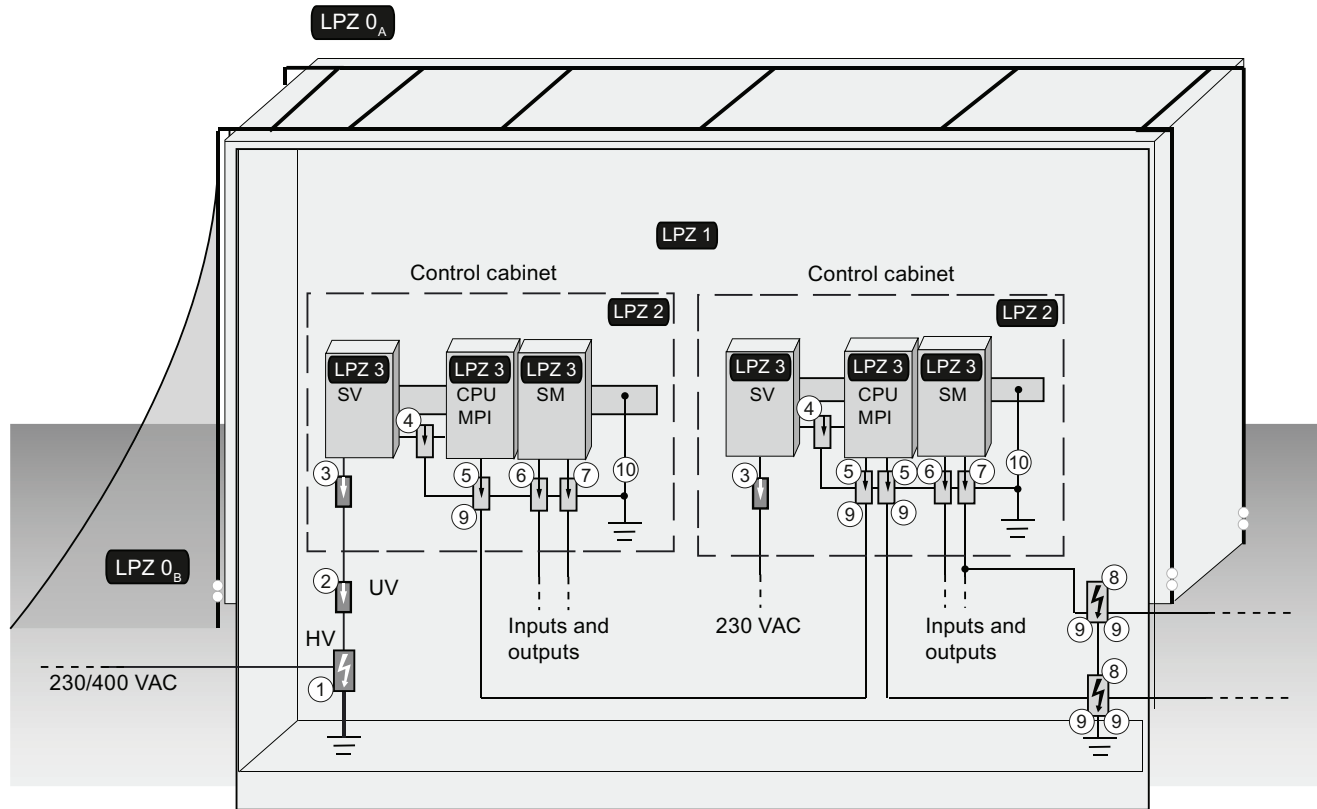

Figure A-3 Source: DEHN+Söhne

Components of the application example

The following table explains the components of the application example:

Seq. no.	Component	Meaning
①	Combination arrester 230/400 VAC supply, DEHNventil® DV M TNC 255 Item no. 951 300 DEHNventil® DV M TNC 255 FM * Part no. 951 305 * DEHNventil® DV M TNS 255 Part no. 951 400 DEHNventil® DV M TNS 255 FM * Part no. 951 405 *	Protection against indirect effects of lightning and overvoltages at zone transition 0 _A → 1 and 0 _A → 2
②	Surge arrester, 230/400 VAC supply, DEHNguard® DG M TNC 275 Item no. 952 300 DEHNguard® DG M TNC 275 FM * Part no. 952 305 * DEHNguard® DG M TNS 275 Part no. 952 400 DEHNguard® DG M TNS 275 FM * Part No. 952 405 *	Protection against indirect effects of lightning and overvoltages at zone transition 1 → 2
③	Surge arrester, 230 VAC supply, DEHNrail DR M 2P 255 Item no. 953 200 DEHNrail DR M 2P 255 FM * Part no. 953 205 * (I _L = 25.0 A)	Protection against indirect effects of lightning and overvoltages at zone transition 2 → 3
④	Surge arrester, BLITZDUCTOR® VT, BVT AD 24, 24 VDC supply Item no. 918 402	Protection against indirect effects of lightning and overvoltages at zone transition 2 → 3
⑤	Surge arrester, RS 485 interface BLITZDUCTOR® XT Basic unit BXT BAS, Part no. 920 300 BLITZDUCTOR® XT Module BXT ML2 BD HFS 5, Part no. 920 271 (2-wire)	Protection against indirect effects of lightning and overvoltages at zone transition 2 → 3
⑥	Surge arrester, digital inputs of modules DEHNconnect RK, DCO RK ME 24 Part no. 919 921 (I _L = 0.5 A) (2-wire)	Protection against indirect effects of lightning and overvoltages at zone transition 2 → 3
⑦	Surge arrester, digital outputs of modules DEHNconnect RK, DCO RK D 5 24 Part no. 919 986 (I _L = 10.0 A) (2-wire)	Protection against indirect effects of lightning and overvoltages at zone transition 2 → 3

Seq. no.	Component	Meaning
⑧	Surge arrester, inputs/outputs of the modules BLITZDUCTOR® XT Basic unit BXT BAS, Part no. 920 300 BLITZDUCTOR® XT, Module BXT ML2 B 180, Part no. 920 211 ($I_L = 1.2 \text{ A}$) (2-wire)	Protection against indirect effects of lightning and overvoltages at zone transition $0_A \rightarrow 1$
⑨	2 EMC spring terminals for the basic unit of the BLITZDUCTOR® XT Part no. 920 395	Direct or indirect shield grounding
⑩	Protective equipotential bonding line $\geq 6 \text{ mm}^2 \text{ Cu}$	Protective equipotential bonding
<p>* Version: With remote indication contact</p> <p>Components of the series BLITZDUCTOR® XT can be remotely monitored with the appropriate accessories. Additional information under (http://www.dehn.de)</p> <p>Direct order of components via: DEHN+SÖHNE GMBH+CO.KG. Hans-Dehn-Str. 1 D-92318 Neumarkt Tel. +49 (0)9181-906-730</p>		

A.3.7 How to protect digital output modules against overvoltages caused by inductance

Inductive overvoltage

Overvoltage occurs, for example, when inductance is deactivated. Examples are relay coils and contactors.

Integrated surge arrester

S7-300 digital output modules are equipped with an integrated surge arrester.

Additional overvoltage protection

Inductive devices require additional surge arresters only in following cases:

- If these can be switched off by additional contacts (e.g. relay contacts).
- If the inductance cannot be controlled by SIMATIC modules, but the overvoltages that occur can nevertheless have a negative effect on SIMATIC.

Note: Request information on relevant surge protection rating from the supplier of inductive devices.

Example: EMERGENCY-OFF relay contact in the output circuit

The figures illustrates an output circuit requiring additional overvoltage protectors.

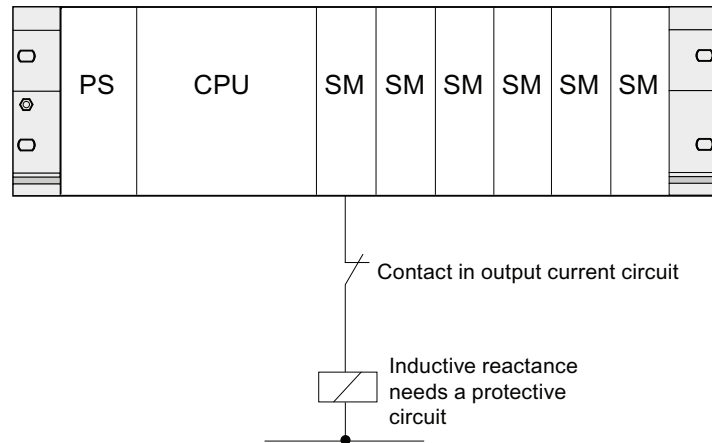

Refer also to the rest of the information in this section.

Circuit for coils operated with DC voltage

The figure below shows DC-operated coils equipped with diodes or Zener diode circuits.

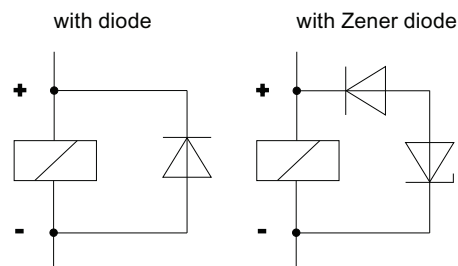

Diode/Zener diode circuits have the following characteristics:

- Switching overvoltages can be avoided.
The Zener diode has a higher switch-off voltage capacity.
- High switch-off delay (6 to 9 times higher than without protective circuit).
The Zener diode switches off faster than a diode circuit.

Circuit for coils operated with AC voltage

The figure shows coils operated with AC voltage and varistor or RC circuit.

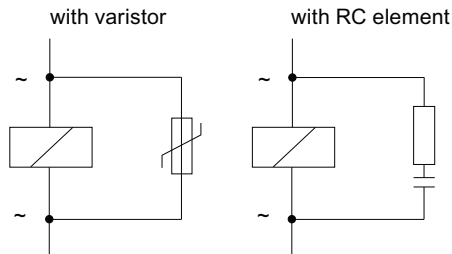

Properties of a protective circuit with **varistor**:

- The amplitude of the opening surge is limited rather than attenuated.
- The surge rise-ratio remains the same.
- Short off-delay.

Properties of a protective circuit with **RC elements**:

- Amplitude and steepness of the opening surge are reduced.
- Short off-delay.

A.4 Functional safety of electronic control equipment

Reliability through basic measures

SIMATIC devices and components are extremely reliable thanks to extensive measures in development and production.

The basic measures include:

- Selection of high-quality components and strategic cooperation with high-performance suppliers
- Measures to prevent static discharge when handling MOS circuits
- Checks and monitoring of the production processes using statistical methods and visual inspections at various production stages
- Heat endurance run at higher ambient temperature as monitoring run-in
- Thorough computer-controlled final inspection and testing of all modules
- Statistical evaluation of all returned systems and components and analysis of service requests to enable the immediate initiation of suitable corrective measures
- Comprehensive computer-aided acquisition of the quality data in the production in order to ensure all the adopted measures

Increased safety measures

In all cases where the occurrence of failures can result in material damage or injury to persons, special measures must be taken to enhance the safety of the entire installation. For these there exist special plant-specific regulations that also have to be taken into consideration by the owner-operator when structuring the control system.

For electronic control equipment with a safety function, the measures that have to be taken to prevent or rectify faults are based on the risks involved in the installation. As of a certain degree of hazard the basic measures mentioned above are no longer sufficient. The owner-operator has to ensure that additional measures are realized for the plant, for example by using SIMATIC S7-F fail-safe control systems.

Important note

The instructions in the operating manual must be followed exactly. Incorrect handling can render measures intended to prevent dangerous faults ineffective, or generate additional sources of danger.

Fail-safe systems in SIMATIC S7

Two fail-safe systems are available for the integration of the safety technology in the SIMATIC S7 automation systems:

- The fail-safe *S7 Distributed Safety* automation system
 - For the implementation of safety concepts in the field of machine and person protection, for example EMERGENCY-OFF facilities for the operation of machine tools/processing machines.
 - In the process industry, for example, for carrying out protection functions for instrumentation-and-control protective systems and burners.
- The fail-safe and optionally fault-tolerant *S7 F/FH systems* automation system for plants in process technology and the oil industry, for example.

Fail-safe and redundant system *S7 F/FH systems*

To increase the availability of the automation system and thereby avoid process interruption in the case of errors, it is possible to build in fail-safe systems as optionally redundant *S7 F/FH systems*. The increased availability is achieved through the redundancy of the following components: Power supply, CPU module, communications and IO devices.

Attainable safety requirements

S7 Distributed Safety F systems and S7 F/FH systems can meet the following safety requirements:

- Safety Integrity Level SIL1 to SIL3 to IEC 61508
- Categories 2 to 4 according to EN 954-1.

Reference

You can find additional information in the *Safety Engineering in SIMATIC S7* system description (A5E00109528-05).

Glossary

Accumulator

Accumulators represent CPU register and are used as buffer memory for download, transfer, comparison, calculation and conversion operations.

Address

An address is the identifier of a specific address or address area. Examples: Input I 12.1; Flag Word MW 25; Data Block DB 3.

Analog module

Analog modules convert process values (e.g. temperature) into digital values which can be processed in the CPU, or they convert digital values into analog manipulated variables.

Application

An application is a program that runs directly on the MS-DOS / Windows operating system. Applications on the programming device are for example STEP 7.

ASIC

ASIC is the acronym for Application Specific Integrated Circuits.

PROFINET ASICs are components with a wide range of functions for the development of your own devices. They implement the requirements of the PROFINET standard in a circuit and allow extremely high packing densities and performance.

Because PROFINET is an open standard, SIMATIC NET offers PROFINET ASICs for the development of your old devices under the name ERTEC .

Backplane bus

The backplane bus is a serial data bus. It supplies power to the modules and is also used by the modules to communicate with each other. Bus connectors interconnect the modules.

Backup memory

Backup memory ensures buffering of the memory areas of a CPU without backup battery. It backs up a configurable number of timers, counters, memory and data bytes,retentive timers, counters, memory bits and data bytes.

Bit memory

Bit memories are part of the CPU's system memory. They store intermediate results of calculations. They can be accessed in bit, word or dword operations.

See System memory

Bus

A bus is a communication medium connecting several nodes. Data can be transferred via serial or parallel circuits, that is, via electrical conductors or fiber optic.

Bus segment

A bus segment is a self-contained section of a serial bus system. Bus segments are interconnected by way of repeaters, for example, in PROFIBUS DP.

Central module

→ CPU

Changing IO devices during operation (changing partner ports)

Functionality of a PROFINET device.

A PROFINET device that supports this function can communicate during operation with changing communication partners at the same port.

Clock memory

flag bit which can be used to generate clock pulses in the user program (1 byte per flag bit).

Note

When operating with S7-300 CPUs, make sure that the byte of the clock memory bit is not overwritten in the user program!

Coaxial cable

A coaxial cable, also known as "coax", is a metal conductor system used in HF transmission circuits, for example, as radio and TV antenna cable, and in modern networks demanding high data transmission rates. The inner conductor of a coaxial cable is sheathed by a tube-like outer conductor. These conductors are separated by plastic insulation. In contrast to other cables, this type of cable provides a high degree of immunity to interference and EMC compatibility.

Code block

A SIMATIC S7 code block contains part of the **STEP 7** user program. (in contrast to a DB: this contains only data.)

Communication processor

Communication processors are modules used for point-to-point and bus topologies.

Component Based Automation

→ *PROFINET CBA*

Compress

The PG online function "Compress" is used to rearrange all valid blocks in CPU RAM in a contiguous area of load memory, starting at the lowest address. This eliminates fragmentation which occurs when blocks are deleted or edited.

Configuration

Assignment of modules to module racks/slots and (e.g. for signal modules) addresses.

Consistent data

Data which belongs together in terms of content and must not be separated is known as consistent data.

For example, the values of analog modules must always be handled as a whole, that is, the value of an analog module must not be corrupted as a result of read access at two different points of time.

Counters

Counters are part of CPU system memory. The content of "Counter cells" can be modified by **STEP 7** instructions (for example, up/down count.)

See also System memory

CP

→ *Communication processor*

CPU

Central processing unit = CPU of the S7 automation system with a control and arithmetic unit, memory, operating system, and interface for programming device.

Cycle control point

The cycle control point is the section of the CPU program processing in which the process image is updated.

Cycle time

The cycle time represents the time a CPU requires for one execution of the user program.

Cyclic interrupt

→ *Interrupt, cyclic interrupt*

Data block

Data blocks (DB) are data areas in the user program which contain user data. There are global data blocks which can be accessed by all code blocks, and instance data blocks which are assigned to a specific FB call.

Data exchange broadcast

→ *Direct data exchange*

Data exchange traffic

→ *Direct data exchange*

Data set routing

Functionality of a module with several network connections. Modules that support this function are able to pass on data of an engineering system (for example parameter data generated by SIMATIC PDM) from a subnetwork such as Ethernet to a field device at the PROFIBUS DP.

Data, static

Static data can only be used within a function block. These data are saved in an instance data block that belongs to a function block. Data stored in an instance data block are retained until the next function block call.

Data, temporary

Temporary data represent local data of a block. They are stored in the L-stack when the block is executed. After the block has been processed, these data are no longer available.

DB

→ *Data block*

DCP

DCP (**D**iscovery and **B**asic **C**onfiguration **P**rotocol). Enables the assignment of device parameters (e.g. the IP address) using manufacturer-specific configuration/programming tools.

Default Router

The default router is the router that is used when data must be forwarded to a partner located within the same subnet.

In STEP 7, the default router is named *Router*. STEP 7 assigns the local IP address to the default router.

Definition: Devices in the PROFINET environment

Within the context of PROFINET, "device" is the generic term for:

- Automation systems (e.g. PLC, PC)
- Field devices (for example, PLC, PC, hydraulic devices, pneumatic devices)
- Active network components (for example, switches, gateways, routers)
- PROFIBUS or other fieldbus systems

The main characteristic of a device is its integration into PROFINET communication by means of Ethernet or PROFIBUS.

The following device types are distinguished based on their attachment to the bus:

- PROFINET devices
- PROFIBUS devices

Detecting the network topology

LLDP (Link Layer Discovery Protocol) is a protocol that is used to detect the closest neighbors. It enables a device to send information about itself and to save information received from neighboring devices in the LLDP MIB. This information can be looked up via the SNMP. This information allows a network management system to determine the network topology.

Determinism

→ *Real Time*

Device

Within the PROFINET context, "device" is the generic term for:

- Automation systems,
- Field devices (for example, PLC, PC)
- Active network components (for example, distributed I/O, valve terminals, drives),
- hydraulic devices and
- pneumatic devices.

The main characteristic of a device is its integration in PROFINET communication over Ethernet or PROFIBUS.

The following device types are distinguished based on their bus connections:

- PROFINET devices
- PROFIBUS devices

Device Name

Before an IO device can be addressed by an IO controller, it must have a device name. In PROFINET, this method was selected because it is simpler to work with names than with complex IP addresses.

The assignment of a device name for a concrete IO device can be compared with setting the PROFIBUS address of a DP slave.

When it ships, an IO device does not have a device name. An IO device can only be addressed by an IO controller, for example for the transfer of project engineering data (including the IP address) during startup or for user data exchange in cyclic operation, after it has been assigned a device name with the PG/PC.

Device replacement without removable medium/programming device

It is easy to replace IO devices that support this function:

- A removable medium (such as a SIMATIC Micro Memory Card) with stored device name is not required.
- The device name does not have to be assigned with the programming device.
- A replaced IO device that has already been put into operation must be reset to factory settings using the "Reset to factory settings" function.

The replaced IO device is assigned the device name by the IO controller and no longer from a removable media or programming device. The IO controller uses the configured topology and the neighboring relationships determined by the IO devices to this purpose. The configured target topology must coincide accordingly with the actual topology.

Diagnostic buffer

The diagnostics buffer represents a buffered memory area in the CPU. It stores diagnostic events in the order of their occurrence.

Diagnostic interrupt

Modules capable of diagnostics operations report detected system errors to the CPU by means of diagnostic interrupts.

Diagnostics

→ *System diagnostics*

Direct data exchange

Direct data exchange is a special communication relationship between PROFIBUS DP nodes. Direct data exchange is characterized by PROFIBUS DP nodes that "listen" on the bus and know which data a DP slave returns to its DP master.

DP master

A master which behaves in accordance with EN 50170, Part 3 is known as a DP master.

DP slave

A slave operated on PROFIBUS with PROFIBUS DP protocol and in accordance with EN 50170, Part 3 is referred to as DP slave.

DPV1

The designation DPV1 means extension of the functionality of the acyclical services (to include new interrupts, for example) provided by the DP protocol. The DPV1 functionality has been incorporated into IEC 61158/EN 50170, volume 2, PROFIBUS.

Electrically isolated

The reference potentials of the control and load circuit of isolated I/O modules are electrically isolated, for example, by means of optocouplers, relays or transformers. Input/output circuits may be grouped.

Equipotential bonding

Electrical connection (equipotential bonding conductor) which eliminates potential difference between electrical equipment and external conductive bodies by drawing potential to the same or near the same level, in order to prevent disturbing or dangerous voltages between these bodies.

Error display

One of the possible reactions of the operating system to a runtime error is to output an error message. Additional reactions: Error reaction in the user program, CPU in STOP.

Error handling via OB

After the operating system has detected a specific error (e.g. access error with **STEP 7**), it calls a dedicated block (Error OB) that determines additional CPU actions.

Error response

Reaction to a runtime error. Reactions of the operating system: It sets the automation system to STOP, indicates the error, or calls an OB in which the user can program a reaction.

ERTEC

→ *ASIC*

Fast Ethernet

Fast Ethernet describes the standard with which data is transmitted at 100 Mbit/s. Fast Ethernet uses the 100 Base-T standard.

FB

→ *Function block*

FC

→ *Function*

FEPRM

→ *Memory Card (MC)*

Flash EPROM

FEPRMs can retain data in the event of power loss, same as electrically erasable EEPROMs. However, they can be erased within a considerably shorter time (FEPRM = Flash Erasable Programmable Read Only Memory). They are used on Memory Cards.

Force

The Force function can be used to assign the variables of a user program or CPU (also: inputs and outputs) constant values.

In this context, please note the limitations listed in the *Overview of the test functions section in the chapter entitled Test functions, Diagnostics and Troubleshooting in the S7-300 Installation manual.*

Function

According to IEC 1131-3, a function (FC) is a code block without static data. A function allows parameters to be passed in the user program. Functions are therefore suitable for programming frequently occurring complex functions, e.g. calculations.

Function block

According to IEC 1131-3, a function block (FB) is a code block with static data. A function block allows parameters to be transferred to the user program. Function blocks are therefore suitable for programming frequently recurring, complex functions, e.g., rules, mode selection.

Functional ground

Grounding which has the sole purpose of safeguarding the intended function of electrical equipment. With functional grounding you short-circuit interference voltage which would otherwise have an unacceptable impact on equipment.

GD circuit

A GD circuit comprises a number of CPUs sharing data by means of global data communication, and is used as follows:

- A CPU broadcasts a GD packet to the other CPUs.
- A CPU sends and receives a GD packet from another CPU.

A GD circuit is identified by a GD circuit number.

GD element

A GD element is generated by assigning shared global data. It is identified by a unique global data ID in the global data table.

GD packet

A GD packet can consist of one or several GD elements transmitted in a single message frame.

Global data

Global data can be addressed from any code block (FC, FB, OB). In particular, this refers to bit memories M, inputs I, outputs Q, timers, counters and data blocks DB. Global data can be accessed via absolute or symbolic addressing.

Global data communication

Global data communication is a procedure that is used to transfer global data between CPUs (without SFCs/SFBs).

Ground

The conductive earth whose electrical potential can be set equal to zero at any point.

Ground potential can be different from zero in the area of grounding electrodes. The term reference ground is frequently used to describe this situation.

Grounding means, to connect an electrically conductive component via an equipotential grounding system to a grounding electrode (one or more conductive components with highly conductive contact to earth).

Chassis ground is the totality of all the interconnected passive parts of a piece of equipment on which dangerous fault-voltage cannot occur.

Ground

The conductive earth whose electrical potential can be set equal to zero at any point.

Ground potential can be different from zero in the area of grounding electrodes. The term reference ground is frequently used to describe this situation.

Grounding means, to connect an electrically conductive component via an equipotential grounding system to a grounding electrode (one or more conductive components with highly conductive contact to earth).

Chassis ground is the totality of all the interconnected passive parts of a piece of equipment on which dangerous fault-voltage cannot occur.

Ground

The conductive earth whose electrical potential can be set equal to zero at any point.

Ground potential can be different from zero in the area of grounding electrodes. The term reference ground is frequently used to describe this situation.

Grounding means, to connect an electrically conductive component via an equipotential grounding system to a grounding electrode (one or more conductive components with highly conductive contact to earth).

Chassis ground is the totality of all the interconnected passive parts of a piece of equipment on which dangerous fault-voltage cannot occur.

GSD file

The properties of a PROFINET device are described in a GSD file (General Station Description) that contains all the information required for configuration.

As with PROFIBUS, you can link a PROFINET device in STEP 7 by means of a GSD file.

In PROFINET IO, the GSD file is in XML format. The structure of the GSD file conforms to ISO 15734, which is the world-wide standard for device descriptions.

In PROFIBUS, the GSD file is in ASCII format.

Hardware interrupt

A hardware interrupt is triggered by interrupt-triggering modules as a result of a specific event in the process. The hardware interrupt is reported to the CPU. The assigned organization block will be processed according to interrupt priority.

HART

English: Highway Addressable Remote Transducer

Hub

→ *Switch*

I-Device

The "I-Device" (intelligent IO device) functionality of a CPU facilitates data exchange with an IO controller and operation of the CPU, for example, as intelligent preprocessing unit of sub processes. Accordingly, the intelligent device is integrated into a "higher-level" IO controller, acting as IO device.

The functionality of the intelligent device ensures that the data is pre-processed in the user program on the CPU. The process values acquired from central or distributed locations (PROFINET IO or PROFIBUS DP) are pre-processed in the user program and provided to a higher-level station via PROFINET IO device interface of the CPU.

Industrial Ethernet

Industrial Ethernet (formerly SINEC H1) is a technology that allows data to be transmitted free of interference in an industrial environment.

Due to the openness of PROFINET, you can use standard Ethernet components. We recommend, however, that you install PROFINET as Industrial Ethernet.

Instance data block

The **STEP 7** user program assigns an automatically generated DB to every call of a function block. The instance data block stores the values of input, output and in/out parameters, as well as local block data.

Interface, MPI-compatible

→ *MPI*

Interrupt

The CPU's operating system distinguishes between different priority classes for user program execution. These priority classes include interrupts, e.g. process interrupts. When an interrupt is triggered, the operating system automatically calls an assigned OB. In this OB the user can program the desired response (e.g. in an FB).

Interrupt, cyclic interrupt

A cyclic interrupt is generated periodically by the CPU in a configurable time pattern. A corresponding OB will be processed.

Interrupt, diagnostic

→ *Diagnostic interrupt*

Interrupt, hardware

→ *Hardware interrupt*

Interrupt, status

A status interrupt can be generated by a DPV1 slave or a PNIO device respectively. At the DPV1 master or the PNIO controller respectively the receipt of the interrupt causes the OB 55 to be called up.

For detailed information on OB 56, refer to the *Reference Manual System Software for S7-300/400: System and Standard Functions*.

Interrupt, time-delay

The delay interrupt belongs to one of the priority classes in SIMATIC S7 program processing. It is generated on expiration of a time started in the user program. A corresponding OB will be processed.

Interrupt, time-delay

→ *Interrupt, time-delay*

Interrupt, time-of-day

The time-of-day interrupt belongs to one of the priority classes in SIMATIC S7 program processing. It is generated at a specific date (or daily) and time-of-day (e.g. 9:50 or hourly, or every minute). A corresponding OB will be processed.

Interrupt, update

An update interrupt can be generated by a DPV1 slave or a PNIO device respectively. At the DPV1 master or the PNIO controller respectively the receipt of the interrupt causes the OB 56 to be called up.

For detailed information on OB 56, refer to the *Reference Manual System Software for S7-300/400: System and Standard Functions*.

Interrupt, vendor-specific

A vendor-specific interrupt can be generated by a DPV1 slave or a PNIO device respectively. At the DPV1 master or the PNIO controller respectively, receipt of the interrupt causes the OB 57 to be called.

For detailed information on OB 57, refer to the *Reference Manual System Software for S7-300/400: System and Standard Functions*.

IP address

To allow a PROFINET device to be addressed as a node on Industrial Ethernet, this device also requires an IP address that is unique within the network. The IP address is made up of 4 decimal numbers with a range of values from 0 through 255. The decimal numbers are separated by a period.

The IP address is made up of

- The address of the (subnet) network and
- The address of the node (generally called the host or network node).

IRT

→ *Isochronous Real Time communications*

Isochronous mode

In order to maximize deterministic performance, the process data, the transmission cycle via PROFIBUS DP or PROFINET IO, as well as the user program are synchronized. The input and output data of the distributed IO devices in the system is acquired and output simultaneously. The isochronous PROFIBUS DP cycle/PROFINET IO cycle acts as the corresponding clock generator.

Isochronous Real Time communications

Synchronized transmission procedure for the cyclic exchange of IO data between PROFINET devices.

A reserved bandwidth within the send clock is available for the IRT / IO data. The reserved bandwidth guarantees that the IRT data can also be transferred even during another high network load (for example TCP/IP communication or additional real time communication) at reserved, synchronized intervals.

LAN

Local Area Network; interconnects multiple computers within a company. The geographical topology of a LAN is limited to the local premises and is only available to the operating company or institution.

LLDP

LLDP (Link Layer Discovery Protocol) is a protocol that is used to detect the closest neighbors. It enables a device to send information about itself and to save information received from neighboring devices in the LLDP MIB. This information can be looked up via the SNMP. This information allows a network management system to determine the network topology.

Load memory

This memory contains objects generated by the programming device. Load memory is implemented by means of a plug-in Micro Memory Card of different memory capacities. The SIMATIC Micro Memory Card must be inserted to allow CPU operation.

Load power supply

Power supply to the signal / function modules and the process I/O connected to them.

Local data

→ *Data, temporary*

MAC address

Each PROFINET device is assigned a worldwide unique device identifier in the factory. This 6-byte long device identifier is the MAC address.

The MAC address is divided up as follows:

- 3 bytes vendor identifier and
- 3 bytes device identifier (consecutive number).

The MAC address is normally printed on the front of the device.

Example: 08-00-06-6B-80-C0

Main memory

The main memory is integrated in the CPU and cannot be extended. It is used to run the code and process user program data. Programs only run in the main memory and system memory.

Master

When a master has the token, it can send data to other nodes and request data from other nodes (= active node).

Media redundancy

Function that ensures network and system availability. Redundant transmission links (ring topology) ensure that an alternative communication path is made available if a transmission link fails.

Memory Card (MC)

Memory Cards are memory media for CPUs and CPs. They are implemented in the form of RAM or FEPRAM. An MC differs from a Micro Memory Card only in its dimensions (MC is approximately the size of a credit card).

MIB

An MIB (Management Information Base) is a data base of a device. SNMP clients access this data base in the device. The S7 device family supports, among others, the following standard MIBs:

- MIB II, standardized in the RFC 1213
- LLDP MIB, standardized in the international standard IEE 802.1AB
- LLDP PNIO-MIB, standardized in the international IEC standard 61158-6-10

Micro Memory Card (MMC)

Micro Memory Cards are memory media for CPUs and CPs. Their only difference to the Memory Card is the smaller size.

Module parameters

Module parameters are values which can be used to configure module behavior. A distinction is made between static and dynamic module parameters.

MPI

The multipoint interface (MPI) represents the programming device interface of SIMATIC S7. It enables multiple nodes (PGs, text-based displays, OPs) to be operated simultaneously by one or more CPUs. Each node is identified by its unique (MPI) address.

MPI address

→ *MPI*

NCM PC

→ *SIMATIC NCM PC*

Nesting depth

A block can be called from another by means of a block call. Nesting depth is referred to as the number of simultaneously called code blocks.

Network

A network consists of one or more interconnected subnets with any number of nodes. Several networks can exist alongside each other.

Network

A network is a larger communication system that allows data exchange between a large number of nodes.

All the subnets together form a network.

Non-isolated

The reference potential of the control and on-load power circuits of non-isolated I/O modules is electrically interconnected.

NTP

The Network Time Protocol (NTP) is a standard for synchronizing clocks in automation systems via Industrial Ethernet. NTP uses the UDP wireless network protocol.

OB

→ *Organization blocks*

OB priority

The CPU operating system distinguishes between different priority classes, for example, cyclic program processing, hardware interrupt controlled program processing. Each priority class is assigned organization blocks (OBs) in which the S7 user can program a response. The OBs are assigned different default priority classes. These determine the order in which OBs are executed or interrupt each other when they appear simultaneously.

Operating state

SIMATIC S7 automation systems know the following operating states: STOP, START, RUN.

Operating system

The CPU operating system organizes all the CPU functions and processes which are not associated with a specific control task.

Organization blocks

Organization blocks (OBs) form the interface between the CPU operating system and the user program. The order in which the user program is executed is defined in the organization blocks.

Parameters

1. Variable of a **STEP 7** code block
2. Variable for declaring module response (one or several per module). All modules have a suitable basic factory setting which can be customized in **STEP 7**. There are static and dynamic parameters.

Parameters, dynamic

Unlike static parameters, you can change dynamic module parameters during runtime by calling an SFC in the user program, e.g. limit values of an analog signal input module.

Parameters, static

Unlike dynamic parameters, static parameters of modules cannot be changed by the user program. You can only modify these parameters by editing your configuration in **STEP 7**, for example, modification of the input delay parameters of a digital signal input module.

PC station

→ *SIMATIC PC Station*

PG

→ *Programming device*

PLC

→ *Programmable logic controller*

PLC

A PLC in the context of SIMATIC S7 --> is a programmable logic controller.

PNO

Technical committee that defines and additional develops the PROFIBUS and PROFINET standards with the following homepage: <http://www.profinet.com>.

Prioritized startup

The term prioritized startup denotes the PROFINET functionality for accelerating the startup of IO devices operated on a PROFINET IO system with RT and IRT communication.

The function reduces the time that configured IO devices require in order to return to cyclic user data exchange in the following scenarios:

- After the power supply has returned
- After a station has come back online
- After the activation of IO devices

Priority class

The S7 CPU operating system provides up to 26 priority classes (or "Program execution levels"). Specific OBs are assigned to these classes. The priority classes determine which OBs interrupt other OBs. Multiple OBs of the same priority class do not interrupt each other. In this case, they are executed sequentially.

Process image

The process image is part of CPU system memory. At the start of cyclic program execution, the signal states at the input modules are written to the process image of the inputs. At the end of cyclic program execution, the signal status of the process image of the outputs is transferred to the output modules.

Process-Related Function

→ *PROFINET Component*

Product version

The product version identifies differences between products which have the same order number. The product version is incremented when forward-compatible functions are enhanced, after production-related modifications (use of new parts/components) and for bug fixes.

PROFIBUS

Process Field Bus - European field bus standard.

PROFIBUS device

A PROFIBUS device has at least one PROFIBUS link with an electric interface (RS485) or an optical interface (polymer optical fiber, POF).

A PROFIBUS device cannot take part directly in PROFINET communication, but must be implemented by means of PROFIBUS master with PROFINET link or Industrial Ethernet/PROFIBUS link (IE/PB Link) with proxy functionality.

PROFIBUS DP

A PROFIBUS with the DP protocol that complies with EN 50170. DP stands for distributed peripheral (IO) = fast, real-time, cyclic data exchange. From the perspective of the user program, the distributed IOs are addressed in exactly the same way as the central IOs.

PROFINET

Within the framework of Totally Integrated Automation (TIA), PROFINET is the consistent additional development of:

- PROFIBUS DP, the established fieldbus and
- Industrial Ethernet, the communication bus for the cell level.

The experience gained from both systems was and is being integrated in PROFINET.

PROFINET as an Ethernet-based automation standard from PROFIBUS International (previously PROFIBUS Nutzerorganisation e. V.) defines a vendor-independent communication, automation, and engineering model.

PROFINET ASIC

→ *ASIC*

PROFINET CBA

As part of PROFINET, PROFINET CBA (Component Based Automation) is an automation concept that focuses on the following:

- Implementation of modular applications
- Machine - machine communication

PROFINET CBA lets you create distributed automation solutions, based on default components and partial solutions. This concept meets the demand for a greater modularity in the field of mechanical and systems engineering by extensive distribution of intelligent processes.

With Component Based Automation you can implement complete technological modules as standardized components that can be used in large systems.

You create the modular, intelligent components of the PROFINET CBA in an engineering tool (which may differ according to the device manufacturer). Components that are formed from SIMATIC devices are created with STEP 7, and are interconnected using the SIMATIC iMAP tool.

PROFINET Component

A PROFINET component includes the entire data of the hardware configuration, the parameters of the modules, and the corresponding user program. The PROFINET component is made up as follows:

- Technological Function

The (optional) technological (software) function includes the interface to other PROFINET components in the form of interconnectable inputs and outputs.

- Device

The device is the representation of the physical programmable controller or field device including the I/O, sensors and actuators, mechanical parts, and the device firmware.

PROFINET device

A PROFINET device always has at least one Industrial Ethernet port. A PROFINET device can also be operated as proxy to act as representative that safeguards Ethernet communication between PROFIBUS devices (PROFIBUS slaves connected to an existing PROFIBUS interface) and additional PROFINET devices on the Ethernet.

PROFINET IO

As part of PROFINET, PROFINET IO is a communication concept that is used to implement modular, distributed applications.

PROFINET IO allows you to create automation solutions, which are familiar to you from PROFIBUS.

PROFINET IO is implemented using the PROFINET standard for programmable controllers.

The STEP 7 engineering tool helps you to structure and configure an automation solution.

In STEP 7 you have the same application view, regardless of whether you are configuring PROFINET devices or PROFIBUS devices. Program your user program in the same way for both PROFINET IO and PROFIBUS DP, since you will use the extended blocks and system status lists for PROFINET IO.

PROFINET IO controller

Device used to address the connected IO devices. This means that the IO controller exchanges input and output signals with assigned field devices. The IO controller is often the controller on which the automation program runs.

PROFINET IO device

A distributed field device that is assigned to one of the IO controllers (e.g. remote IO, valve terminals, frequency converters, switches)

PROFINET IO Supervisor

Programming device, PC or HMI device used for commissioning and diagnostics.

PROFINET IO system

PROFINET IO controller with assigned PROFINET IO devices.

Programmable logic controller

Programmable controllers (PLCs) are electronic controllers whose function is stored as a program in the control unit. The structure and wiring of the device does not therefore depend on the controller's function. A programmable logic controller is structured like a computer. It consists of a CPU with memory, input/output modules and an internal bus system. The IOs and the programming language are oriented to control engineering needs.

Programming device

Programming devices are essentially compact and portable PCs which are suitable for industrial applications. They are identified by a special hardware and software for programmable logic controllers.

Proxy

The PROFINET device with proxy functionality is the substitute for a PROFIBUS device on Ethernet. The proxy functionality allows a PROFIBUS device to communicate not only with its master but also with all nodes on PROFINET.

With PROFINET, existing PROFIBUS systems can be integrated into the PROFINET communication with the aid of an IE/PB link, for example. The IE/PB link then handles communication via PROFINET on behalf of the PROFIBUS components.

In this way, you can link both DPV0 and DPV1 slaves to PROFINET.

Proxy

→ *Proxy*

Proxy functionality

→ *Proxy*

RAM

RAM (Random Access Memory) is a semiconductor read/write memory.

Real Time

Real time means that a system processes external events within a defined time.

Determinism means that a system reacts in a predictable (deterministic) manner.

In industrial networks, both these requirements are important. PROFINET meets these requirements. PROFINET is implemented as a deterministic real-time network as follows:

- The transfer of time-critical data between different stations over a network within a defined interval is guaranteed.

To this end, PROFINET has an optimized communication channel for real-time communication: real time (RT): Real Time (RT).

- An exact prediction of the time at which the data transfer takes place is possible.
- It is guaranteed that problem-free communication using other standard protocols, for example, industrial communication for a programming device/PC, can take place within the same network.

Real Time

→ *Real Time*

Reduction ratio

The reduction rate determines the send/receive frequency for GD packets on the basis of the CPU cycle.

Reference ground

→ *Ground*

Reference potential

Voltages of participating circuits are referenced to this potential when they are viewed and/or measured.

Restart

On CPU start-up (e.g. after is switched from STOP to RUN mode via selector switch or with POWER ON), OB100 (restart) is initially executed, prior to cyclic program execution (OB1). On restart, the input process image is read in and the **STEP 7** user program is executed, starting at the first instruction in OB1.

Retentivity

A memory area is considered retentive if its contents are retained even after a power loss and transitions from STOP to RUN. The non-retentive area of memory flag bits, timers and counters is reset following a power failure and a transition from the STOP mode to the RUN mode.

Retentive can be the:

- Bit memory
- S7 timers
- S7 counters
- Data areas

Router

A router interconnects two subnets. A router works in a similar way to a switch. With a router, however, you can also specify which communication nodes may communicate via the router and which may not. The communication nodes on various sides of a router can only communicate with one another if you have explicitly enabled communication between these nodes via the router. Real-time data cannot be exchanged beyond subnet boundaries.

RT

→ *Real Time*

Runtime error

Errors occurred in the PLC (that is, not in the process itself) during user program execution.

Segment

→ *Bus segment*

Send cycle

Period between two successive intervals for IRT or RT communication. The send cycle is the shortest possible transmit interval for exchanging data. The calculated update times are multiples of the send cycle.

The minimum possible update time thus depends on the minimum send cycle of the IO controller that can be set.

If both the IO controller and the IO device support a send cycle of 250 µs, you can achieve a minimum update time of 250 µs.

It is also possible to operate IO devices that only support a send cycle of 1 ms on an IO controller that works with a send cycle of 250 µs. The minimum update time for the IO devices concerned is then at least 1 ms, however.

SFB

→ *System function block*

SFC

→ *System function*

Shared Device

The "Shared Device" functionality makes it possible to distribute the submodules of an IO devices to different IO controllers.

Signal module

Signal modules (SM) form the interface between the process and the PLC. There are digital input and output modules (input/output module, digital) and analog input and output modules. (Input/output module, analog)

SIMATIC

The term denotes Siemens AG products and systems for industrial automation.

SIMATIC NCM PC

SIMATIC NCM PC is a version of STEP 7 tailored to PC configuration. For PC stations, it offers the full range of functions of STEP 7.

SIMATIC NCM PC is the central tool with which you configure the communication services for your PC station. The configuration data generated with this tool must be downloaded to the PC station or exported. This makes the PC station ready for communication.

SIMATIC NET

Siemens Industrial Communication division for Networks and Network Components.

SIMATIC PC Station

A "PC station" is a PC with communication modules and software components within a SIMATIC automation solution.

Slave

A slave can only exchange data after being requested to do so by the master.

SNMP

SNMP (Simple Network Management Protocol) makes use of the connectionless UDP transport protocol. It consists of two network components, similar to the client/server model. The SNMP manager monitors the network nodes and the SNMP agents collect the various network-specific information in the individual network nodes and stores it in a structured form in the **MIB** (Management Information Base). This information allows a network management system to run detailed network diagnostics.

SSL

→ *System status list*

STARTUP

A START-UP routine is executed at the transition from STOP to RUN mode. Can be triggered by means of the mode selector switch, or after power on, or by an operator action on the programming device. An S7-300 performs a restart.

STEP 7

STEP 7 is an engineering system and contains programming software for the creation of user programs for SIMATIC S7 controllers.

Subnet

All the devices connected by switches are located in the same network - a subnet. All the devices in a subnet can communicate directly with each other.

All devices in the same subnet have the same subnet mask.

A subnet is physically restricted by a router.

Subnet mask

The bits set in the subnet mask decides the part of the IP address that contains the address of the subnet/network.

In general:

- The network address is obtained by an AND operation on the IP address and subnet mask.
- The node address is obtained by an AND NOT operation on the IP address and subnet mask.

Substitute value

Substitute values are configurable values which output modules transfer to the process when the CPU switches to STOP mode.

In the event of an I/O access error, a substitute value can be written to the accumulator instead of the input value which could not be read (SFC 44).

Switch

Network components used to connect several computers or network segments in a local network (LAN).

In contrast to PROFIBUS DP, Industrial Ethernet consists of point-to-point connections: Each communication node is connected directly with one other communication node.

If a communication node needs to be connected to several other communication nodes, this communication node is connected to the port of an active network component- a switch. Other communications nodes (including switches) can then be connected to the other ports of the switch. The connection between a communication node and the switch remains a point-to-point link.

The task of a switch is therefore to regenerate and distribute received signals. The switch "learns" the Ethernet address(es) of a connected PROFINET device or other switches and forwards only the signals intended for the connected PROFINET device or connected switch.

A switch has a certain number of ports). At each port, connect a maximum of one PROFINET device or an additional switch.

Two switch variants are available for PROFINET IO systems: as external switches with enclosure, or as integrated component of an S7 CPU or S7 CP, or as integrated switch of a distributed I/O system ET 200, such as in the S7-CPU 317-2 PN/DP.

The SIEMENS SCALANCE X product family contains switches with electrical and optical ports, or with a combination of both variants. SCALANCE X202-2IRT, for example, provides 2 electrical and 2 optical ports and supports IRT communication.

With STEP 7, you can configure, analyze and address switches from the SCALANCE X device family as PROFINET IO devices.

System diagnostics

System diagnostics refers to the detection, evaluation, and signaling of errors that occur within the PLC, for example programming errors or module failures. System errors can be indicated by LEDs or in **STEP 7**.

System function

A system function (SFC) is a function that is integrated in the operating system of the CPU and can be called in the STEP 7 user program, when necessary.

System function block

A system function block (SFB) is a function block integrated in the CPU operating system that can be called in the STEP 7 user program when required.

System memory

System memory is an integrated RAM memory in the CPU. System memory contains the address areas (e.g. timers, counters, bit memories) and data areas that are required internally by the operating system (for example, communication buffers).

System status list

The system status list contains data that describes the current status of a SIMATIC S7. You can always use this list to obtain an overview of the following points:

- Status of the SIMATIC S7 extension.
- The current CPU configuration and configurable signal modules.
- The current states and processes in the CPU and in configurable signal modules.

Terminating resistor

The terminating resistor is used to avoid reflections on data links.

Timer

→ *Timers*

Timers

Timers are part of CPU system memory. The content of timer cells is automatically updated by the operating system, asynchronously to the user program. **STEP 7** instructions are used to define the precise function of the timer cell (for example, on-delay) and to initiate their execution (for example, start).

TOD interrupt

→ *Interrupt, time-of-day*

Token

Allows access to the bus for a limited time.

Topology

Network structure. Commonly used structures:

- Linear bus topology
- Ring topology
- Star topology
- Tree topology

Topology configuration

All the interconnected ports of the PROFINET devices in STEP 7 projects and their relationships to each other.

Transmission rate

Data transfer rate (in bps)

Twisted-pair

Fast Ethernet via twisted-pair cables is based on the IEEE 802.3u standard (100 Base-TX). The transmission medium is a shielded 2x2 twisted-pair cable with an impedance of 100 Ohm (AWG 22). The transmission characteristics of this cable must meet the requirements of category 5.

The maximum length of the connection between the terminal and the network component must not exceed 100 m. The connections are implemented according to the 100 Base-TX standard with the RJ-45 connector system.

UDT

User Defined Type: User-defined data type with any design.

Ungrounded

Having no direct electrical connection to ground

Update time

Within this time interval, an IO device/IO controller in the PROFINET IO system is supplied with new data by the IO controller/IO device. The send cycle can be configured separately for each IO device and determines the interval at which data are sent from the IO controller to the IO device (outputs) as well as data from the IO device to the IO controller (inputs).

User program

In SIMATIC, we distinguish between the operating systems of the CPU and user programs. The user program contains all instructions, declarations and data for signal processing through which a system or process can be controlled. It is assigned to a programmable module (for example CPU, FM) and can be structured in smaller units (blocks).

Varistor

Voltage-dependent resistor

WAN

A network beyond LAN boundaries which allows, for example, intercontinental communication. Legal rights do not belong to the user but to the provider of the communication network.

Index

A

- Actuator/Sensor Interface, 57, 94
- Address
 - Analog module, 131
 - Digital module, 130
 - MPI, PROFIBUS DP, 59
 - Technological functions, 132
- Addressing
 - Device name, 137
 - Integrated I/O, 132
 - IP address, 137
 - On PROFIBUS DP, 135
 - on PROFINET IO, 136
 - slot-specific,
 - User-specific, 129
- Ambient condition
 - Climatic, 259
 - Mechanical, 258
 - Operating conditions, 258
- Analog module, addresses, 131
- Approvals, 251
 - CE, 252
 - CSA, 252
 - FM, 253
 - IEC 61131, 254
 - Marine, 254
 - UL, 252
 - Use in industrial environments, 254
 - Use in residential areas, 255
- ASI (Actuator/Sensor Interface), 57, 94

B

- Backup
 - Firmware, 191
 - Project data, 195
- Baud rate
 - Maximum, 58
 - MPI cable length, 63
 - PROFIBUS cable length, 64
 - Stub cables, 64
- Bus cable, 65
 - Bus connector, 124
 - Installation, 66

- Properties, 65
 - Versions available, 65
- Bus connector, 124
 - Fast Connect, 124
 - MPI, PROFIBUS wiring, 124
 - PROFINET, 126
 - removing, 125
 - Setting the terminating resistor, 125
- Bus connector
 - Installing, 125/125
- Bus termination, 70
- Bus topology with SFC 103, 215

C

- Cabinet
 - Dimensions, 40
 - EMC-compliant configuration, 269
 - power loss dissipated, 42
 - Selection, 39
 - Types, 40
- Cable
 - Outside buildings:, 277
 - Preparing, 112
 - Proper routing, 265
 - Routing equipotential conductors, 274
 - shield, 272
 - Shield connection element, 121
 - Within buildings, 275
- Cable length
 - Extension with RS485 repeater, 64
 - Maximum, 67
 - MPI subnet, 63
 - PROFIBUS subnet, 64
 - PROFINET, 85
 - Stub cables, 64
- Cable shield, 50
- Cable shielding, 266
- CE approval, 252
- Commissioning
 - Check list, 145
 - CPU as DP master, 168
 - CPU as DP slave, 172
 - CPU memory reset, 150
 - Errors, 144
 - Hardware, 141, 142
 - Micro Memory Card, 147
 - Module, 147

- PROFIBUS DP, 166
 - PROFINET IO, 180
 - Software, 143, 144
 - Commissioning the module
 - connecting a PG, 155
 - Monitoring and modifying variable, 161
 - Commissioning the DP master
 - CPU 31x PN/DP, 168
 - CPU 31x-2 DP, 168
 - CPU 31xC-2 DP, 168
 - Commissioning the DP slave
 - CPU 31x PN/DP, 173
 - CPU 31x-2 DP, 173
 - CPU 31xC-2 DP, 173
 - Component Based Automation (CBA), 79
 - Configuring
 - Examples for subnets, 68
 - General information about the subnet, 56
 - MPI/PROFIBUS subnet, 58
 - Procedure for the PROFINET IO system, 182
 - PROFIBUS subnet, 73
 - Configuring, basics, 29
 - Central unit, 30
 - Component dimensions, 32
 - Expansion module, 30
 - Grounding, 43, 49
 - Installation, 31
 - Load power supply, 54
 - Module arrangement, 35
 - Protective measures, 43
 - Specified clearance dimensions, 34
 - Subnet, 56
 - Connecting
 - PG, 155, 156, 157, 158
 - Sensors and actuators, 111
 - Spring terminals, 111
 - ungrounded/grounded, 160
 - Connecting actuators, 111
 - Connecting sensors, 111
 - Constant bus cycle time, 170
 - Controller, 82
 - PROFINET CBA, 82
 - PROFINET IO, 82
 - Controlling, 209
 - Coupling
 - Interference-proof, 37
 - CPU
 - CPU memory reset, 150, 154
 - Wiring, 109
 - Wiring conditions, 106
 - CPU as DP master, 168
 - Constant bus cycle time, 170
 - CPU 31x PN/DP, 168
 - CPU 31xC-2 DP, 168
 - CPU 3x-2 DP, 168
 - Diagnostics, 230
 - Isochronous Updating of Process Image Partitions, 170
 - Startup of CPU 31x-2 DP, 169
 - Sync/Freeze, 171
 - CPU as DP slave, 172
 - CPU 31x PN/DP, 173
 - CPU 31x-2 DP, 173
 - CPU 31xC-2 DP, 173
 - GSD files, 172
 - Startup, 173
 - CPU memory reset, 150
 - Formatting the Micro Memory Card, 154
 - Internal sequence on the CPU, 152
 - MPI/DP interface parameters, 153
 - With mode selector switch, 151
 - CSA approval, 252
- ## D
- Data
 - Back up, 195
 - Reading/saving service data, 205
 - Data consistency, 135, 137
 - Degree of protection IP 20, 260
 - Delivery state of the CPU
 - Lamp images during reset, 198
 - Properties, 197
 - Restoring, 197
 - Detecting operating mode transitions
 - In the DP master, 173
 - In the DP slave, 169
 - Device ID, 242
 - Diagnostic address
 - Direct data exchange, 233
 - DP master and DP slave, 231
 - PROFIBUS DP, 236
 - PROFIBUS DP, 236
 - Diagnostics, 230
 - configured address range, 243
 - Diagnostic buffer, 214
 - DP master, 230
 - LED display, 213
 - LEDs of the CPU, 219
 - Maintenance, 249
 - PROFINET IO, 247
 - SF LED for hardware faults, 222
 - SF LED for software errors, 221
 - Type of error, 212

- using "Diagnosing hardware",
 - with LEDs, 219
 - with system functions, 214
 - Digital module
 - Address, 130
 - Protection against inductive overvoltage, 290
 - Digital output module
 - Replacement fuse, 202
 - Replacing fuses, 203
 - Direct data exchange, 233
 - Disconnecting the wiring, 119
 - DP Master, interrupts, 238
- E**
- Electromagnetic compatibility (EMC), 255
 - Electromagnetic interference, 263
 - Electrostatic discharge, 255
 - EMC (Electromagnetic compatibility), 255
 - Disturbance variables, 255
 - Radio interference, 256
 - EMC (ElectroMagnetic Compatibility), 263
 - EMC-compliant installation, 267
 - Ground connections, 267
 - Rules, 265
 - Special measures, 266
 - Equipotential bonding, 273
 - Equipotential bonding conductor, 50
 - Error LEDs, 219
 - Error-free operation, general rules, 261
 - Example
 - CPU 314C-2 DP as MPI and PROFIBUS node, 72
 - Data exchange between the DP master and DP slave, 176
 - Direct data exchange via DP CPUs, 179
 - Isolated module, 47
 - Load power supply, 55
 - Maximum distance, 69
 - Non-isolated module, 48
 - Routing, 93
 - Terminating resistor, 70
 - Using blocks to read slave diagnostics information, 234
- F**
- Fail-safe system, 292
 - Fast Connect, 124
 - Disconnecting, 119
 - Twisted pair, 87
 - Wiring, 116, 118
 - Wiring rules, 117
 - Fast Connect technology, 115
 - Fieldbus integration, 77
 - Firmware
 - Backup on Micro Memory Card, 189
 - Update, 192
 - Update, 192
 - Update online, 193
 - FM approval, 253
 - Forcing, 210
 - Front connector
 - Removing the coding, 200, 201
 - Front connectors, 111
 - encoding, 114
 - Module assignment, 111
 - plugging, 114
 - Preparing the cables, 112
 - Wiring, 113
 - Wiring conditions, 106
 - wiring to spring terminals, 111
- G**
- Ground connections, 267
 - Grounded power supply, 43
 - Grounding
 - Cable shield, 50
 - CPU 31xC overview, 52
 - Load circuit, 50
 - measures, 49
 - non-isolated/isolated, 46
 - Overview, 53
 - Group error LED
 - Hardware faults, 222
 - Software errors, 221
 - GSD files, 172
- I**
- I&M data
 - Read / write, 206
 - SSL partial lists, 207
 - Identification and maintenance data, 206
 - IEC 61131, 254
 - Initial power on, 149
 - installation
 - Coupling, 37
 - EMC compatible, 263
 - Horizontal, 31
 - Layout of the modules, 35
 - Reference potential, grounded, 45

- Vertical, 31
- Installation
 - in cabinets, 39
 - Layout of the modules, 36
 - Module, 100
- Installation
 - Reference potential, grounded, 4444
- Installation - examples
 - Maximum configuration, 38
 - MPI subnet, 68
 - PROFIBUS subnet, 71
 - PROFINET subnet, 88
 - Protection against overvoltage, 288
 - S7-300, 25
- Installation Dimensions of the Modules, 32
- Installation, basic rules, 23
- Installing
 - EMC-compliant, 267
 - Module, 200
 - Mounting rail, 97
 - Wall mounting (EMC-compliant), 270
- Insulation test, 260
- Interconnection
 - PROFIBUS and PROFINET, 77
- Interface
 - MPI, 61
 - Parameter handling during CPU memory reset, 153
 - PROFIBUS DP, 62
 - PtP, 94
 - Send cycle, 85
 - Update time, 85
- Interface module, 36
- Interference-proof coupling, 37
- Interrupt data
 - Generating a diagnostics interrupt, 246, 247
 - Process interrupt, structure, 245
- Interrupts on the DP Master, 238
- IP address assignment, 137
- Isochronous mode, 170

L

- Labeling strips, 120
- Layout on the racks, 35, 36
- LED, 213
- Length of the network, 85
- Lightning protection, 278
 - Equipotential bonding, 281, 282, 284, 286
 - Lightning protector, 284, 286
 - Safety zones concept, 279
- Load circuit, 50
- Load current determination, 54

- Load power supply
 - Example, 55
 - Properties, 54
- Load voltage, reference potential, 51

M

- Mains, 43
- Maintenance, 249
 - Backup of firmware on Micro Memory Card, 191
 - Backup of the project data, 195
 - Delivery state, 197
 - Firmware update, 191
 - Maintenance, 249
 - Module replacement, 198
 - Replacing fuses, 202
- Marine approval, 254
- Maximum configuration, 38
- MIB (Management Information Base), 217
- Micro Memory Card, 154
 - Firmware backup, 189
 - Formatting, 154
 - Initial power on, 149
 - Inserting/removing, 148
- Module
 - Assembly dimensions, 32
 - Assigning slot numbers, 102
 - Commissioning, 147
 - installing, 100, 101, 200
 - Isolated, 46
 - labeling, 120
 - Layout on the rack, 35, 36
 - Micro Memory Card, 147
 - Non-isolated, 46
 - removing, 199
 - replacing, 198
 - Sequence, 100
 - Start addresses, 127
- Module replacement
 - Reaction of the S7-300, 201
 - Rules, 100, 198
- Monitoring, 161
- Monitoring and modifying variable, 161
 - establishing a connection to the CPU, 164
 - Modifying outputs in STOP mode, 165
 - Setting the trigger points, 163
 - Variable table, 162
- Mounting rail, 97
 - connecting the protective conductor, 107
 - Fixation, 98
 - installing, 99
 - Length, 32

- Mounting the ground conductor, 97
- MPI (Multi Point Interface), 56
 - Baud rate, maximum, 58
 - Number of nodes, maximum, 59
- MPI (multi-point interface)
 - Interface, 61
- MPI address, 59
- MPI interface
 - Connectable devices, 61
 - Parameter handling during CPU memory reset, 153
- MPI subnet
 - Cable length, 63
 - CPU 314C-2 DP as node, 72
 - Example, 68
 - Maximum distance, 69
 - Terminating resistor, 70
- MPI/DP interface
 - Commissioning the IO system, 181
 - Parameter handling during CPU memory reset, 153
- Multi-Point Interface, 56

- N**
- Network diagnostics, 217
- Number of nodes, maximum, 59

- O**
- Operating system, 189
- Overview
 - CPU 31xC grounding, 52
 - Diagnostic information for PROFINET, 248
 - Grounding, 53
 - PROFINET IO functions, 90
 - S7-300 components, 26
- Overvoltage protection, 278
 - Components, 285, 287
 - Example for EMERGENCY STOP, 291
 - Inductive overvoltage, 290
 - Sample configuration, 288

- P**
- PG
 - Access to remote networks, 92
 - Connecting, 155, 156, 157, 158
 - MPI addresses for service PGs, 159
 - Ungrounded/grounded configuration, 160
- Point-to-point connection, 57
- Potential difference, 50
- Power supply module
 - Selecting the mains voltage, 108
 - Wiring, 109
 - Wiring conditions, 106
- PROFIBUS, 59
- PROFIBUS device, 74
- PROFIBUS DP
 - Addressing, 135
 - Addressing the user data area, 135
 - Baud rate, maximum, 58
 - Commissioning, 166
 - Comparison with PROFINET, 75
 - Direct data exchange, 178
 - DP address ranges, 167
 - DP diagnostic addresses, 167
 - Number of nodes, maximum, 59
 - Software required, 166
- PROFIBUS DP address, 59
- PROFIBUS DP interface, 62
 - Connectable devices, 63
 - Diagnostics with status and error LEDs, 224
 - Operating modes with two DP interfaces, 62
 - Troubleshooting, 224
- PROFIBUS subnet, 64
 - Bus cable, 65
 - Cable length, 64
 - CPU 314C-2 DP as node, 72
 - Example, 71
- PROFINET, 136
 - Cable length, 85
 - CBA (Component based Automation), 57
 - Commissioning, 214
 - Configuring the IO system, 182
 - Controller, 82
 - IO and CBA, distinguishing features, 81
 - IO and CBA, interaction, 80
 - Length of the network, 85
 - Send cycle, 84
 - Twisted pair, 85
 - Update time, 83
 - Update times for CPU 319-3 PN/DP, 85
- PROFINET CBA, 82
 - Controller, 82
 - Distinguishing features compared to IO, 81
 - Interaction with IO, 80
- PROFINET device
 - Definition, 73
 - Status and error displays, 226
- PROFINET interface
 - Commissioning the IO system, 182
 - Diagnostics with status and error LEDs, 226
 - IO device, troubleshooting, 229
 - Parameter handling during CPU memory reset, 153

- Troubleshooting, 227
- Update time, 85
- PROFINET IO, 136
 - Address ranges of the CPUs, 180
 - Addressing, 136
 - Addressing the user data area, 137
 - Commissioning, 180
 - Comparison with PROFIBUS, 75
 - Controller, 82
 - Diagnostics, 247
 - Distinguishing features compared to CBA, 81
 - Interaction with CBA, 80
 - Overview of functions, 90
- PROFINET IO system
 - Commissioning, 181
 - Commissioning via MPI/DP, 181
 - Commissioning via PROFINET interface, 182
 - Configuration procedures, 182
 - CPU startup for operation as intelligent device, 186
 - CPU startup for operation as IO controller, 185
- PROFINET subnet
 - Example, 88
 - Units, 73
- Protection class, 260
- Protective conductor
 - Connecting with the mounting rail, 107
 - Fixing screw, 97
- Protective grounding, 49
- Proxy functionality, 78, 82
- PtP (Point-to-Point coupling), 57
- PtP interface, 94

R

- Radio interference, 256
- Recycling, 7
- Redundant system, 292
- Reference potential
 - EMC compatible, 267
 - grounded, 44
 - ungrounded, 45
- Removing a module, 199
- Replacing fuses, 203
- Router, 92
- Routing, 274
- RS 485
 - Bus connector, 66
 - Maximizing cable lengths, 67
- RS 485 repeater, 67

S

- S7-300
 - Accessories, 96
 - Commissioning, 141
 - Component overview, 26
 - Error-free operation, general, 261
 - Installation, example, 25
 - Lightning protection, 278
 - Overvoltage protection, 278
 - Tools and materials required, 96
- Scope of the manual, 3
- Scope of this documentation, 15
- Segment, 58
 - Cable lengths, 63
 - General, 58
- Selecting the mains voltage, 108
- Send cycle
 - Odd values, 85
 - PROFINET, 84
- Service data, 205
- SF LED, 222
- SFB52, 215
- SFC 103, 215
- SFC 13, 215
- SFC 14, 137
- SFC 51, 215
- SFC 6, 215
- SFC14, 135
- SFC15, 135, 137
- Shield connection element, 121
 - installing, 122
 - Terminating the cable, 123
- Shielding, 272
- Shielding terminals, 33
- Shipping conditions, 257
- SIMATIC iMap, 79
- SIMATIC Manager, 161
- Slave diagnostics
 - Interrupt data, 245
 - Interrupt status, structure, 245
 - Module status, structure, 244
 - reading with blocks, 233
 - Reading, example, 234
 - Structure of identifier-related diagnostics, 243
 - Syntax of the diagnostics datagram, 239
- Slot numbers, 102
- Slot-specific addressing, 127
- SNMP (Simple Network Management Protocol), 217
- Specified clearance dimensions, 34
- Standards, 251
- Startup
 - as DP slave, 173

- CPU 31xC-2 DP as a DP master, 169
- CPU as intelligent device, 186
- CPU as IO controller, 185
- Status and error LEDs
 - CPU with DP interface, 224
 - CPU with PROFINET interface, 226
 - PROFINET IO devices, 229
 - SF LED, 221, 222
 - Total, 219
- stepping mode, 209
- STOP LED, 151, 152
- Storage conditions, 257
- Stub cables, 64
 - Baud rate, 64
 - Length, 64
- Subnet
 - General information, 56
 - MPI subnet, 58
 - PROFIBUS subnet, 58, 73
 - Segment, 63
- SYNC/FREEZE, 171
- System functions for diagnostics, 214

T

- Technical specifications
 - Electromagnetic compatibility (EMC), 255
 - Shipping and storage conditions, 257
 - Standards and certifications, 251
- Terminating resistor
 - MPI subnet, 70
 - Setting the bus connector, 125
- Test voltage, 260
- Transfer memory
 - Address range, 175
 - Example program, 176
 - Rules, 177
 - User data transfer, 174
 - User data transfer in STOP mode, 178
- Trigger points, 163

U

- UL approval, 252
- ungrounded/grounded, 160
- Update
 - Communication interruption, 191
 - Using micro memory card, 192
- Update
 - Online,
- Update time

- CPU 31x PN/DP, 84
- PROFINET IO, 83
- User data area
 - Addressing PROFIBUS DP, 135
 - Addressing PROFINET IO, 137
- User data transfer, 174

V

- Variable table, 162
- Variables, 161
 - Controlling, 209
 - Forcing, 210
 - Monitoring, 209

W

- Wiring, 109
 - Accessories, tools, material, 105
 - CPU, 109
 - Fast Connect, 116
 - Front connectors, 113
 - Power supply module, 109
 - Wiring conditions, 106

