

SIEMENS

SIMATIC

Automation System S7-300 ET 200M Distributed I/O Device Fail-safe signal modules

Installation and Operating Manual

Translation of original operating instructions

Preface

Product overview	1
Configuration options	2
Configuration and parameter assignment	3
Addressing and installation	4
Wiring	5
Fault reaction and diagnostics	6
General technical data	7
Digital modules	8
Analog modules	9
Safety protector	10
Diagnostics data of the signal modules	A
Dimensional drawings	B
Accessories and order numbers	C
Response times	D
Switching capacitive and inductive loads	E



07/2013

A5E00085586-11

Legal information

Warning notice system

This manual contains notices you have to observe in order to ensure your personal safety, as well as to prevent damage to property. The notices referring to your personal safety are highlighted in the manual by a safety alert symbol, notices referring only to property damage have no safety alert symbol. These notices shown below are graded according to the degree of danger.

 DANGER
indicates that death or severe personal injury will result if proper precautions are not taken.
 WARNING
indicates that death or severe personal injury may result if proper precautions are not taken.
 CAUTION
indicates that minor personal injury can result if proper precautions are not taken.
NOTICE
indicates that property damage can result if proper precautions are not taken.

If more than one degree of danger is present, the warning notice representing the highest degree of danger will be used. A notice warning of injury to persons with a safety alert symbol may also include a warning relating to property damage.

Qualified Personnel

The product/system described in this documentation may be operated only by **personnel qualified** for the specific task in accordance with the relevant documentation, in particular its warning notices and safety instructions. Qualified personnel are those who, based on their training and experience, are capable of identifying risks and avoiding potential hazards when working with these products/systems.

Proper use of Siemens products

Note the following:

 WARNING
Siemens products may only be used for the applications described in the catalog and in the relevant technical documentation. If products and components from other manufacturers are used, these must be recommended or approved by Siemens. Proper transport, storage, installation, assembly, commissioning, operation and maintenance are required to ensure that the products operate safely and without any problems. The permissible ambient conditions must be complied with. The information in the relevant documentation must be observed.

Trademarks

All names identified by ® are registered trademarks of Siemens AG. The remaining trademarks in this publication may be trademarks whose use by third parties for their own purposes could violate the rights of the owner.

Disclaimer of Liability

We have reviewed the contents of this publication to ensure consistency with the hardware and software described. Since variance cannot be precluded entirely, we cannot guarantee full consistency. However, the information in this publication is reviewed regularly and any necessary corrections are included in subsequent editions.

Preface

[ID: 431798411]

Purpose of this manual

This reference manual provides a pool of information about the control functions, the functionality and technical specifications of the fail-safe signal modules of a S7-300 system.

Basic knowledge required

Working with this manual requires general knowledge of automation engineering. It is also assumed that you have sufficient knowledge of the *STEP 7* Basic Software, of the S7-300 automation system, and of the ET 200M distributed I/O device.

Scope of this manual

Module	Order number	as of product version
Safety protector	6ES7195-7KF00-0XA0	03
Bus module for safety protector	6ES7195-7HG00-0XA0	01
SM 326; DI 24 x DC 24 V	6ES7326-1BK02-0AB0	01
SM 326; DI 8 x NAMUR	6ES7326-1RF00-0AB0	05
SM 326; DO 8 x DC 24V/2A PM	6ES7326-2BF41-0AB0	01
SM 326; DO 10 x DC 24V/2A	6ES7326-2BF01-0AB0	01
SM 326; F-DO 10 x DC 24V/2A PP	6ES7326-2BF10-0AB0	01
SM 336; AI 6 x 13Bit	6ES7336-1HE00-0AB0	04
SM 336; F-AI 6 x 0/4 ... 20 mA HART	6ES7336-4GE00-0AB0	01

What's new compared to the previous version

This manual was updated and supplemented with the description of:

- Support of PROFINET IO
- the new functions of the SM 326; F-DO 10 x DC 24V/2A PP
- the new functions of the SM 326; DI 24 x DC 24 V
- the new functions of the SM 326; DO 8 x DC 24 V/2A PM
- SIL3/Cat.4/PLe can be achieved without safety protector (see section "Safety protector (Page 321)")

Approvals

The S7-300 system complies with the requirements and criteria of IEC 61131, Part 2. In addition, CSA, UL, and FM approvals are available for S7-300.

The S7-300 fail-safe signal modules have also been certified for use in safety mode to:

- SIL3 (Safety Integrity Level) according to IEC 61508:2000
- Performance Level (PL) e and category 4 according to ISO 13849-1:2006 or EN ISO 13849-1:2008

CE certifications

See section "Standards and Approvals (Page 61)".

C-Tick-Mark for Australia

See section "Standards and Approvals (Page 61)".

Standards

See section "Standards and Approvals (Page 61)".

Position in the IT environment

The additional references you require for working with fail-safe modules are listed below.

This manual contains corresponding cross-references to additional documentation.

Documentation	Brief description of relevant contents
<i>ET 200M Distributed I/O Device Manual</i>	Describes the ET 200M hardware (including the configuration, assembly and wiring of IM 153 in combination with modules of the S7-300 family)
<i>Operating Instructions S7-300, CPU 31xC and CPU 31x: Installation</i>	Describes the configuration, installation, wiring, addressing, and commissioning of S7-300 systems
<i>Reference manual Automation systems S7-300, ET 200M, Ex I/O Modules</i>	The SM 326; DI 8 × NAMUR is part of the SIMATIC S7 Ex digital module family. It is to be used in compliance with installation guidelines for SIMATIC S7-Ex digital modules. The reference manual provides detailed guidelines for the configuration of SIMATIC S7-Ex digital modules.
<i>Manual Automation Systems Principles of Explosion Protection</i>	Describes the basic principles of explosion protection

Documentation	Brief description of relevant contents
<i>Safety Engineering in SIMATIC S7</i> system description	<ul style="list-style-type: none"> • Provides an overview of the use, configuration and functionality of S7 Distributed Safety and S7 F/FH fail-safe automation systems • Contains a summary of detailed technical information relating to fail-safe engineering in S7-300 and S7-400 systems • Includes information on the calculation of monitoring and response times of S7 Distributed Safety and S7 F/FH fail-safe systems
for integration in the S7 F/FH fail-safe system	<ul style="list-style-type: none"> • The <i>S7 F/FH Systems Configuring and Programming</i> manual describes the tasks required to create and commission an S7 F/FH System fail-safe system. • The <i>Automation System S7-400, M7-400, Hardware and Installation</i> manual describes the installation and wiring of S7-400 systems. • The <i>S7-400H Configurable Controllers, Fault-Tolerant Systems</i> manual describes the CPU 41x-H central modules and the tasks required to set up and commission an S7-400H fault-tolerant system. • The <i>CFC for SIMATIC S7</i> manual/online help describe programming with CFC.
For integration in the F-system S7 Distributed Safety	<p>The <i>S7 Distributed Safety, Configuring and Programming</i> manual and online help describe:</p> <ul style="list-style-type: none"> • the configuration of fail-safe CPU and I/O • how to program a fail-safe CPU in F-FBD or F-LAD <p>Documentation required, depending on the F-CPU used:</p> <ul style="list-style-type: none"> • The <i>S7-300, CPU 31xC and CPU 31x: Installation</i> operating instructions describe how to install and wire S7-300 systems. • The <i>CPU 31xC and CPU 31x, Technical Specifications</i> manual describes the CPUs 315-2 DP and PN/DP, the CPU 317-2 DP and PN/DP, and the CPU 319-3 PN/DP. • The <i>Automation System S7-400 Hardware and Installation</i> manual describes the installation and wiring of S7-400 systems. • The <i>Automation System S7-400 CPU Specifications</i> reference manual describes the CPU 416-2 and the CPU 416-3 PN/DP. • The <i>ET 200S IM 151-7 CPU Interface Module</i> manual describes the IM 151-7 CPU. • Every applicable F-CPU has its own Product Information. The Product Information describes only the deviations from the corresponding standard CPUs.

Documentation	Brief description of relevant contents
<i>STEP 7</i> manuals	<ul style="list-style-type: none"> • The <i>Configuring Hardware and Communication Connections with STEP 7 V5.x</i> manual describes the operation of the relevant standard tools of <i>STEP 7</i>. • The <i>System and Standard Functions</i> reference manual describes functionality for access to/ diagnostics of distributed I/O.
<i>STEP 7</i> online help	<ul style="list-style-type: none"> • Describes the operation of <i>STEP 7</i> standard tools • Contains information on the configuration and parameter assignment of modules and intelligent slaves in <i>HW Config</i> • Contains a description of the programming languages FBD and LAD
<i>PCS 7</i> manuals	<ul style="list-style-type: none"> • Describe the handling of the <i>PCS 7</i> control system (required if fail-safe I/O are implemented in a master control system)

The entire SIMATIC S7 documentation on CD-ROM is available on request.

Guide

This manual describes the S7-300 fail-safe modules and comprises both instructive and reference sections (technical specifications and appendices).

It contains essential information about the fail-safe signal modules:

- Installation and use
- Configuring and parameter assignment
- Addressing, installation and wiring
- Evaluating diagnostics data
- Technical specifications
- Order numbers

Conventions

The terms "safety technology" and "fail-safe technology" are used synonymously in this manual. The same applies to the use of the terms "fail-safe" and "F-". "F-SM" is a synonym of "fail-safe signal module".

""*S7 Distributed Safety*" and "*S7 F Systems*" in italic letters denote optional packages for the fail-safe systems "S7 Distributed Safety" and "S7 F/FH Systems".

Recycling and disposal

The S7-300 can be recycled due to its low content of pollutants. Contact a company which is certified for the disposal of electronic scrap for environment-friendly disposal and recycling of your old device.

Additional support

Your local Siemens representative will be pleased to provide answers to any open issue relating to the use of products described in this manual.

You will find information on who to contact on the Web (<http://www.siemens.com/automation/partner>).

A guide to the technical documentation for the various SIMATIC products and systems is available on the Web (<http://www.siemens.de/simatic-tech-doku-portal>).

You will find the online catalog and online ordering system on the Web (<http://mall.automation.siemens.com>).

Training Centers

We offer courses to help you get started with the SIMATIC S7 automation system. Contact your regional training center or the central training center in 90327 Nuremberg, Germany.

You will find more information on the Web (<http://www.sitrain.com>).

H/F Competence Center

The H/F Competence Center in Nuremberg offers special workshops on *SIMATIC S7* fail-safe and fault-tolerant automation systems. The H/F Competence Center also provides support in terms of on-site engineering, commissioning, and troubleshooting.

For questions about workshops, etc., contact: hf-cc.aud@siemens.com

Technical Support

To contact Technical Support for all Industry Automation products, use the Support Request Web form (<http://www.siemens.com/automation/support-request>).

You can find additional information about our Technical Support on the Web (<http://www.siemens.com/automation/service>).

Service & Support on the Internet

In addition to our documentation, we also offer a comprehensive technical knowledge base in the Internet (<http://www.siemens.com/automation/service&support>).

There you will find:

- the Newsletter which provides the latest information about your products
- The right documents; using our Service & Support search functions
- A forum where users and experts from all over the world exchange ideas
- Your local contact partner for Industry Automation products in our Contact Partners database
- Information about on-site service, repairs, spare parts, and much more is available under "Repairs, spare parts, and consulting".

Important information concerning the safe operation of your plant

Note

Plants with safety-oriented characteristics are subject to special requirements for operational safety for which the operator is responsible. The supplier also undertakes to conform to special measures for product monitoring. Siemens publishes a special newsletter to keep plant operators informed about product developments and properties which may form important issues in terms of operational safety. You should subscribe to the corresponding newsletter in order to obtain the latest information and to allow you to modify your plant accordingly. Please go to the Internet

(<https://www.automation.siemens.com/WW/newsletter/guiThemes2Select.aspx?HTTPS=REDIR&subjectID=2>) and register for the following newsletters:

- SIMATIC S7-300
- SIMATIC S7-400
- Distributed I/O
- SIMATIC Industrial Software

Activate the "News" check box to subscribe to the corresponding newsletter.

Table of contents

	Preface	3
1	Product overview	13
1.1	Introduction	13
1.2	Using fail-safe signal modules	13
1.3	Guide to commissioning fail-safe signal modules	17
1.4	What is PROFINET IO?	18
2	Configuration options	19
2.1	Introduction	19
2.2	Configuration with F-SMs in Standard Mode	20
2.3	Configuration with F-SMs in Safety Mode	21
3	Configuration and parameter assignment	25
3.1	Configuring	25
3.2	Parameter Assignment	28
3.3	Firmware update via HW Config	29
3.4	I&M identification data	31
4	Addressing and installation	33
4.1	Address Assignments in the CPU	33
4.2	Addressing the Channels	35
4.3	Assigning the PROFIsafe address	37
4.3.1	Introduction	37
4.3.2	Assigning PROFIsafe Address (Starting Address of F-SM)	38
4.3.3	Assigning PROFIsafe Address (F_destination_address)	41
4.4	Installing	44
5	Wiring	45
5.1	Safe Functional Extra-Low Voltage for Fail-Safe Signal Modules	46
5.2	Wiring Fail-Safe Signal Modules	48
5.3	Replacing Fail-Safe Signal Modules	49
5.4	Sensor and Actuator Requirements for F-SMs in Safety Mode	50
6	Fault reaction and diagnostics	53
6.1	Fault reactions of the F-SMs	53
6.1.1	Reactions to Faults in Standard Mode	53
6.1.2	Fault reactions in safety mode	54
6.1.3	Fault reactions in safety mode with parameter setting "Keep last valid value"	57

6.2	Diagnosis of Faults of F-SMs	58
7	General technical data	61
7.1	Introduction.....	61
7.2	Standards and Approvals.....	61
7.3	Electromagnetic Compatibility.....	66
7.4	Shipping and storage conditions	71
7.5	Mechanical and Climatic Environmental Conditions	72
7.6	Specifications for Nominal Line Voltages, Isolation Tests, Protection Class, and Degree of Protection	74
8	Digital modules	75
8.1	Introduction.....	75
8.2	Discrepancy analysis at the fail-safe digital input modules.....	76
8.3	SM 326; DI 24 x DC 24V.....	78
8.3.1	Properties, Front View, Connection Diagram, and Block Diagram	78
8.3.2	Use cases for the SM 326; DI 24 x 24V DC.....	84
8.3.3	Application 1 : Standard Mode.....	86
8.3.4	Application 2 : Standard operation with high availability	87
8.3.5	Application 3: Safety mode SIL2/Cat.3/PLd.....	90
8.3.6	Application 4: Safety mode SIL2/Cat.3/PLd with high availability (in S7 F/FH Systems only).....	92
8.3.7	Application 5: Safety mode SIL3/Cat.4/PLe.....	95
8.3.8	Application 6: Safety mode SIL3/Cat.4/PLe with high availability (in S7 F/FH Systems only).....	100
8.3.9	Diagnostic messages of SM 326; DI 24 x DC 24V	105
8.3.10	Technical data - SM 326; DI 24 x DC 24V.....	108
8.4	SM 326; DI 8 x NAMUR	111
8.4.1	Properties, front view, wiring diagram and block diagram	111
8.4.2	Special Features when Wiring SM 326; DI 8 x NAMUR for Hazardous Areas	115
8.4.3	Cases of application of SM 326; DI x 8 NAMUR.....	119
8.4.4	Application 1: standard mode and application 3: safety mode SIL 2 (Category 3).....	120
8.4.5	Application 2: standard mode with high availability and application 4: safety mode SIL 2 (Category 3) with high availability (only in S7 F/FH Systems)	121
8.4.6	Application 5: Safety mode SIL3/Cat.4/PLe.....	123
8.4.7	Application 6: Safety mode SIL3/Cat.4/PLe with high availability (in S7 F/FH Systems only).....	125
8.4.8	Diagnostic Messages for SM 326; DI 8 x NAMUR.....	127
8.4.9	Technical data - SM 326; DI 8 x NAMUR	130
8.5	SM 326; DO 8 x DC 24V/2A PM	133
8.5.1	Properties, front view, wiring diagram and block diagram	133
8.5.2	SM 326; DO 8 x DC 24V/2A PM applications	137
8.5.3	Application 1: Safety Mode SIL2/Cat.3/PLd and application 2: Safety mode SIL3/Cat.4/PLe.....	137
8.5.4	Diagnostic messages of SM 326; DO 8 x DC 24V/2A PM.....	140
8.5.5	Technical data - SM 326; DO 8 x DC 24V/2A PM	145
8.6	SM 326; DO 10 x DC 24V/2A (6ES7326-2BF01-0AB0)	148

8.6.1	Properties, front view, wiring diagram and block diagram	148
8.6.2	SM 326; DO 10 x DC 24V/2A applications	152
8.6.3	Application 1: Standard mode, application 3: Safety Mode SIL2/Cat.3/PLd and application 5: Safety mode SIL3/Cat.4/PLe	153
8.6.4	Application 2: standard mode with high availability, application 4: Safety Mode SIL2/Cat.3/PLd with high availability and application 6: Safety mode SIL3/Cat.4/PLe with high availability (in S7 F/FH Systems only)	156
8.6.5	Parallel Connection of Two Outputs for Dark Period Suppression	159
8.6.6	Diagnostics messages of SM 326; DO 10 x DC 24V/2A	160
8.6.7	Technical Data - SM 326; DO 10 x DC 24V/2A	166
8.7	SM 326; F-DO 10 x DC 24V/2A PP (6ES7326-2BF10-0AB0)	170
8.7.1	Properties, front view, wiring diagram and block diagram	170
8.7.2	SM 326; F-DO 10 x DC 24V/2A PP applications	174
8.7.3	Applications 1 to 4	176
8.7.4	Application 5: Safety mode SIL3/Cat.4/PLe	176
8.7.5	Application 5.1: Wiring two outputs in parallel for dark period suppression	179
8.7.6	Application 6: Safety mode SIL3/Cat.4/PLe with high availability (in S7 F/FH Systems only)	182
8.7.7	Diagnostic messages SM 326; F-DO 10 x DC 24V/2A PP	185
8.7.8	Technical data - SM 326; F-DO 10 x DC 24V/2A PP	190
9	Analog modules	193
9.1	Introduction	193
9.2	SM 336; AI 6 x 13 Bit	194
9.2.1	Analog value representation	194
9.2.2	Properties, front view, wiring diagram and block diagram	196
9.2.3	Applications of SM 336; AI 6 x 13 Bit	202
9.2.4	Application 1 : Standard Mode	204
9.2.5	Application 2: standard mode with high availability	208
9.2.6	Application 3: Safety mode SIL2/Cat.3/PLd	215
9.2.7	Application 4: Safety mode SIL2/Cat.3/PLd with high availability (in S7 F/FH Systems only)	218
9.2.8	Application 5: Safety mode SIL3/Cat.4/PLe	223
9.2.9	Application 6: Safety mode SIL3/Cat.4/PLe with high availability (in S7 F/FH Systems only)	226
9.2.10	Diagnostic Messages for SM 336; AI 6 x 13 Bit	232
9.2.11	Technical data - SM 336; AI 6 x 13Bit	235
9.3	SM 336; F-AI 6 x 0/4 ... 20 mA HART	239
9.3.1	Analog value representation	239
9.3.2	Properties, front view, wiring diagram and block diagram	241
9.3.3	Applications of SM 336; F-AI 6 x 0/4 ... 20 mA HART	247
9.3.4	Applications and wiring schemes	258
9.3.4.1	Calculation of the residual supply voltage at the transducer	259
9.3.5	Applications 1 and 2	261
9.3.6	Application 3: Safety mode SIL3/Cat.3/PLe	262
9.3.7	Application 4: Safety mode SIL3/Cat.3/PLe with high availability (in S7 F/FH Systems only)	264
9.3.8	Application 5: Safety mode SIL3/Cat.4/PLe	267
9.3.9	Application 6: Safety mode SIL3/Cat.4/PLe with high availability (in S7 F/FH Systems only)	270
9.3.10	Application 7: Safety mode SIL3/Cat.4/PLe	273

9.3.11	Application 8: Safety mode SIL3/Cat.4/PLe with high availability (in S7 F/FH Systems only).....	275
9.3.12	Application 9: Safety mode SIL3/Cat.4/PLe with three modules and high availability (in S7 F/FH Systems only).....	278
9.3.13	Diagnostic messages of SM 336; F-AI 6 x 0/4 ... 20 mA HART	281
9.3.14	Technical Data - SM 336; F-AI 6 x 0/4 ... 20 mA HART	287
9.3.15	Parameters of analog input module F-AI 6 x 0/4 ... 20mA HART	292
9.3.15.1	Setting smoothing of analog values	293
9.3.15.2	Parameter assignment of discrepancy analysis for 1oo2 evaluation.....	295
9.3.15.3	Deactivate one channel of a channel pair for 1oo1 evaluation.....	302
9.3.16	HART basics	302
9.3.16.1	What is HART?	302
9.3.16.2	Properties of HART	302
9.3.16.3	Principles of HART operation.....	303
9.3.16.4	Integration of the HART field devices	305
9.3.16.5	Using HART	306
9.3.16.6	HART for safety-oriented applications	307
9.3.17	Data record interface and user data	312
9.3.17.1	Overview of the data record interface and user data of the HART communication.....	312
9.3.17.2	Diagnostic data records	314
9.3.17.3	HART communication records	314
9.3.17.4	Parameter records of the HART channels	319
9.3.17.5	User data interface, input range (reading)	320
10	Safety protector	321
10.1	Introduction.....	321
10.2	Properties, Front View, and Block Diagram.....	321
10.3	Configuration Variants.....	323
10.4	Technical Specifications.....	326
A	Diagnostics data of the signal modules	327
A.1	Introduction.....	327
A.2	Structure and Content of Diagnostic Data	327
B	Dimensional drawings	337
B.1	Signal Module	337
B.2	Safety protector.....	340
C	Accessories and order numbers	341
C.1	Accessories and Order Numbers	341
D	Response times	343
D.1	Response Times	343
E	Switching capacitive and inductive loads.....	349
	Glossary	353
	Index	367

Product overview

1.1 Introduction [ID: 431456907]

In this chapter

The product overview provides information about

- the integration of fail-safe signal modules in SIMATIC S7 fail-safe automation systems
- available fail-safe signal modules
- steps to take, starting with the selection and ending with the commissioning of fail-safe modules.

1.2 Using fail-safe signal modules [ID: 431462283]

Fail-safe automation system

Fail-safe automation systems (F-systems) are used in plants which are subject to more stringent safety standards. F-systems are used to control processes and to force the plant into a safe state after shutdown. That is, F-systems control processes which do not pose a risk to human beings or to the environment when shut down immediately.

Fail-safe signal modules

Compared to standard modules of the S7-300 module family, the fail-safe signal modules differ in terms of their internal two-channel structure. The two integrated processors monitor each other, automatically test the I/O circuits, and force the fail-safe signal module into safe state when a fault/error has been detected. The F-CPU communicates with the fail-safe signal module by means of the safety-oriented PROFIsafe bus profile.

Types of fail-safe signal modules

Fail-safe signal modules (short name: F-SM) available:

Table 1- 1 Types of fail-safe signal modules

Fail-safe signal modules	Capable of redundancy
SM 326; DI 24 x DC 24V	Yes
SM 326; DI 8 x NAMUR	Yes
SM 326; DO 8 x DC 24V/2A PM	No
SM 326; DO 10 x DC 24V/2A	Yes

1.2 Using fail-safe signal modules [ID: 431462283]

Fail-safe signal modules	Capable of redundancy
SM 326; F-DO 10 x DC 24V/2A PP	Yes
SM 336; AI 6 x 13 Bit	Yes
SM 336; F-AI 6 x 0/4 ... 20 mA HART	Yes

Interface modules that support operation with fail-safe signal modules

The table below lists the interface modules which support operation with fail-safe signal modules:

Table 1- 2 Supported interface modules

Interface module	Order number
IM 153-2	6ES7153-2AA02. and higher (as of product version 05, firmware V1.1.0)
IM 153-2 FO	6ES7153-2AB01. and higher (as of product version 04, firmware V1.1.0)
IM 153-2/IM 153-2 FO	6ES7153-2BA0./-2BB0.

The SM 336; F-AI 6 x 0/4 ... 20 mA HART can be operated with the following interface modules:

Table 1- 3 Supported interface modules for SM 336; F-AI 6 x 0/4 ... 20 mA HART

Interface module	Order number
IM 153-2/IM 153-2 FO	6ES7153-2BA0./-2BB0.

The SM326; F-DO 10 x DC24V/2A PP can be used for fail-safe I-Slave-Slave communication (in F-System S7 Distributed Safety) with the following interface modules only:

Interface module	Order number
IM 153-2	6ES7153-2BA02. (as of firmware version V5.0.13)

Optional applications for fail-safe signal modules

S7-300 fail-safe signal modules support applications for:

- S7-300 automation systems (centrally in S7-300; distributed in ET 200M)
- S7-400 automation systems (distributed in ET 200M)

Note

To use the HART function of the SM 336, F-AI 6 x 0/4 ... 20 mA HART analog module requires distributed implementation in ET 200M.

F-System with fail-safe signal modules

The figure below shows an example configuration of an *S7 Distributed Safety* F-system with fail-safe signal modules/modules in S7-300, ET 200M, and ET 200S.

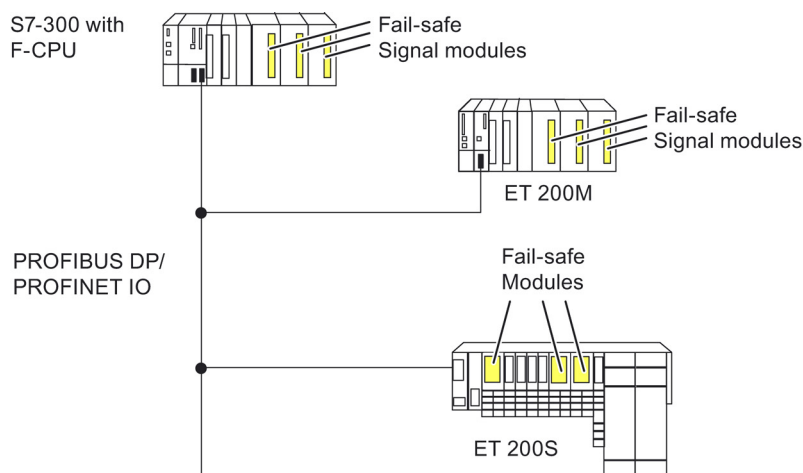

Figure 1-1 Fail-safe S7 Distributed Safety automation system

Operation in standard mode

Except for the SM 326; DO 8 x DC 24V/2A PM, the SM 326; F-DO 10 x DC 24V/2A PP and the SM 336; F-AI 6 x 0/4 ... 20 mA HART, you can operate all other fail-safe signal modules in standard mode with more stringent diagnostics requirements. When operated in standard mode, the fail-safe signal modules respond similar to standard S7-300 I/O modules.

Operation in safety mode

You can implement the fail-safe signal modules for operation in safety mode. Configure safety mode in *HW Config* of *STEP 7* and using the address selector switch on the rear panel of the fail-safe signal module. The "SAFE" LED is lit when safety mode is active at the signal module.

Operation in safety mode with parameter setting "Keep last valid value" with digital output modules

You can only operate the SM 326; F-DO 10 x DC 24V/2A PP with parameter setting "Keep last valid value" according to EN54-2/-4 or NFPA72. Configure safety mode in *HW Config* of *STEP 7* and using the address selector switch on the rear panel of the fail-safe signal module. The "SAFE" LED is lit when safety mode is active at the signal module.

For more information, refer to the sections "Fault reactions in safety mode (Page 54)" and "Fault reactions in safety mode with parameter setting "Keep last valid value" (Page 57)".

Safety Integrity Levels supported

The fail-safe signal modules feature integrated safety functions for operation in safety mode. The section below outlines the Safety Integrity Levels that can be achieved in safety mode through assignment of the safety function parameters in *STEP 7* using the optional package *S7 Distributed Safety* or *S7 F Systems*, and by specific arrangement and wiring of the sensors and actuators:

Table 1- 4 Safety Integrity Levels that can be achieved in safety mode

Safety Integrity Level in safety mode *	
According to IEC 61508:2000	According to ISO 13849-1:2006 or EN ISO 13849-1:2008
SIL 2	Cat. 3/PLd
SIL 3	Cat. 4/PLe

* Valid only if "Keep last valid value" was not set with parameters in digital output modules.

Enhanced availability in standard and safety mode

You can enhance availability by means of redundant operation of the F-SMs fail-safe signal modules in *standard mode* (exception: SM 326; DO 8 x DC 24V/2A PM, SM 326; F-DO 10 x DC 24V/2A PP and SM 336; F-AI 6 x 0/4 ... 20 mA HART).

In safety mode, you can operate the F-SMs redundantly in **S7 F/FH Systems** F-systems (with the exception of SM 326; DO 8 x DC 24V/ 2A PM).

Options of inserting redundant signal modules, depending on availability requirements (for example configurations, refer to "Safety Engineering in SIMATIC S7, System Description (<http://support.automation.siemens.com/WW/view/en/37231510>)"):

- Separately in two ET 200M distributed I/O devices
- In the same ET 200M distributed I/O device

Software requirements of redundant operation of F-SMs are described in the section "Configuration and parameter assignment (Page 25)".

1.3 Guide to commissioning fail-safe signal modules [ID: 431459595]

Introduction

The table below lists all important tasks related to the commissioning of fail-safe signal modules in S7-300 or ET 200M.

Commissioning sequence, starting with the selection of the F-SMs

Table 1- 5 Commissioning sequence, starting with the selection of the F-SMs

Step	Procedure	See
1.	Selecting the F-SMs to be installed	Product catalog; chapter <i>Digital modules</i> ; chapter <i>Analog module</i>
2.	Setup of the mode of operation (standard or safety mode), configuration and parameterization of the F-SM	Chapter <i>Configuring and parameter assignment</i> ; chapter <i>Addressing and installing</i>
3.	Installing F-SMs	Chapter <i>Addressing and installing</i>
4.	Wiring the F-SMs	Chapter <i>Wiring</i>
5.	Commissioning of the F-SMs	<i>ET 200M Distributed I/O Device manual</i> , or <i>S7-300, CPU 31xC and CPU 31x Operating Manual Installation</i>
6.	Run diagnostics if commissioning was not successfully completed.	Chapter <i>Fault reactions and diagnostics</i> ; Chapter <i>Digital Module</i> ; Chapter <i>Analog Module</i>

1.4 What is PROFINET IO? [ID: 15035118859]

Definition

PROFINET IO is an open transmission system with real-time functionality defined in accordance with the PROFINET standard. This standard defines a manufacturer-independent communication, automation and engineering model.

Accessories for wiring the PROFINET components are available in industrial quality.

- PROFINET discards the hierarchical PROFIBUS master/slave concept and deploys a provider/consumer principle instead. The modules of an I/O device that will be subscribed to by an IO controller are defined within the engineering phase.
- The quantity framework is extended in accordance with the options offered on PROFINET IO. Parameter limits are not exceeded during configuration.
- The transmission rate is 100 Mbps.
- The configuration interface for users is generally the same as that on PROFIBUS DP (the system is configured with *HW Config*).

Additional information on PROFINET IO is available in the PROFINET system description (<http://support.automation.siemens.com/WW/view/en/19292127>).

Topology of a PROFINET IO network

The figure below shows a typical PROFINET IO network topology. Existing PROFIBUS slaves can be integrated using an IE/PB link.

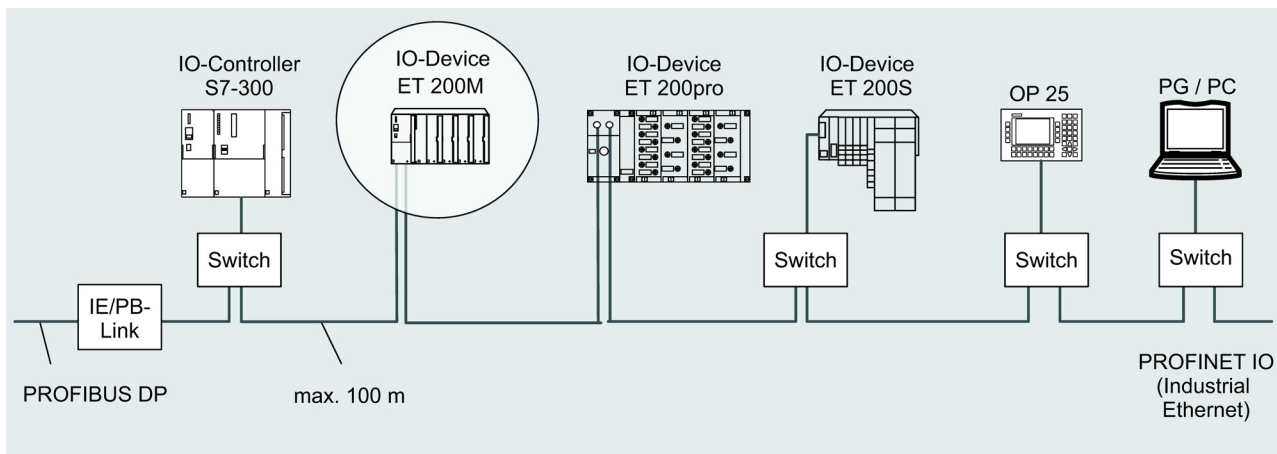

Figure 1-2 Typical structure of a PROFINET IO network

Configuration options

2.1 Introduction [ID: 431529867]

In this chapter

This chapter contains information about:

- Central and distributed configuration with F-SMs
- Components which can be used for F-SMs in standard mode
- Components which can be used for F-SMs in safety mode
- Options of combining F-SMs and standard modules in the same configuration

Central and distributed configuration

All fail-safe signal modules support operation in standard and safety mode in a central S7-300 system and in a distributed system with ET 200M distributed I/O devices.

Note

To use the HART function of the SM 336, F-AI 6 x 0/4 ... 20 mA HART analog module requires distributed implementation in ET 200M.

2.2 Configuration with F-SMs in Standard Mode [ID: 431524491]

Configuration variants in standard mode

When operated in standard mode, the fail-safe signal modules respond similar to standard S7-300 I/O modules (abbreviated: standard modules). The configuration variants are similar to the variants of an S7-300 or ET 200M with standard modules.

Exception: The SM 336 F-AI 6 x 0/4 ... 20 mA HART, SM 326; F-DO 10 x DC 24V/2A PP and SM 326; DO 8 x DC 24V/2A PM operate in safety mode only.

CPUs approved for use in S7-300 systems (central configuration)

All CPUs of the S7-300 family can be implemented in a central configuration when operating the fail-safe signal modules in standard mode.

Approved IM 153 in ET 200M (distributed configuration)

All IM 153-2/-2 FO interfaces of the ET 200M distributed I/O device can be used when operating the fail-safe signal modules in standard mode.

Combinations of fail-safe and standard modules supported for operation in standard mode

S7-300/ET 200M support the combined operation of fail-safe signal modules and standard modules in standard mode.

Additional information

For detailed information on S7-300 configuration variants, refer to the *S7-300, CPU 31xC and CPU 31x: Installation* manual.

For detailed information on the configuration of ET 200M, refer to the *ET 200M Distributed I/O Device* manual.

For detailed information on implementing fail-safe signal modules as redundant I/O in S7 FH systems, refer to the *S7-400H Automation Systems; Fault-Tolerant Systems* manual.

2.3 Configuration with F-SMs in Safety Mode [ID: 431527179]

Configuration variants in safety mode

Criteria which determine configuration variants of the F-SMs for operation in safety mode:

- Configuration (central or distributed)
- Safety Integrity Level of the configuration
- Availability of the configuration

CPUs approved for use in S7-300 systems (central configuration)

All F-CPU's of the S7-300 family can be used in a central configuration in safety mode.

Note

You can, however, install the SM 326; DO 8 x DC 24V/2A PM centrally with all F-CPU's of the S7-300 spectrum with:

- CPU 315F-2 DP, as of order no. 6ES7315-6FF01-0AB0, firmware version V2.0.9
 - CPU 317F-2 DP, as of order no. 6ES7317-6FF00-0AB0, firmware version V2.1.4
-

Approved IMs in ET 200M (distributed configuration)

The IM 153-2/-2 FO interface modules of the ET 200M distributed I/O device support operation of the fail-safe signal modules in standard mode.

Additional information on the supported IMs is available in the chapter "Preface (Page 3)".

Combinations of fail-safe and standard modules supported for operation in safety mode

WARNING

The applicable precautions against accidental contact for standard components are sufficient for applications with Safety Integrity Level **SIL 2/Cat. 3/PLd** and lower (see the *S7-300 Module Data reference manual*).

Applications with Safety Integrity Level **SIL 3/Cat. 4/PLe** require certain measures beyond accidental contact protection to prevent hazardous overvoltages of F-circuits via the power supply and backplane bus, even in the event of a fault. A safety protector is available for the protection of the central and distributed configuration of F-SMs against negative influences from the backplane bus.

In order to protect the modules against negative influences from the power supply, Siemens has issued a set of rules governing the implementation of power supply modules, standard I/O and F I/O (refer to chapter *PELV for fail-safe modules*).

Rules for using the safety protector

The safety protector is used to protect the F-SMs from any overvoltage developing in the case of a fault/error.

 WARNING
<p>The safety protector must be used for SIL3/Category 4/PLe applications:</p> <ul style="list-style-type: none"> • Only with operation of <ul style="list-style-type: none"> – SM 336; AI 6 x 13 Bit (6ES7336-1HE00-0AB0) – SM 326; DI 8 x NAMUR (6ES7326-1RF00-0AB0) – SM 326; DO 10 x DC 24V/2A (6ES7326-2BF01-0AB0) – SM 326; DI 24 x DC 24V (bis 6ES7326-1BK01-0AB0) – SM 326; DO 8 x DC 24V/2A PM (6ES7326-2BF40-0AB0) • if the F-SMs are integrated centrally in an S7-300. • if the PROFIBUS DP is wired using a copper cable. • If PROFIBUS DP is installed with fiber-optic cables, and if standard and fail-safe signal modules must be operated on the same ET 200M.

Configuration variants depending on availability

Table 2- 1 Configuration variants of fail-safe systems based on availability

In system	Configuration variant	Description	Availability
S7 Distributed Safety	<ul style="list-style-type: none"> • Single-channel I/O 	Single-channel, fail-safe (F-CPU and F-SMs not redundant)	Normal availability
S7 F/FH Systems			
S7 FH systems	<ul style="list-style-type: none"> • Single-channel switched I/O 	Single-channel, switched, fail-safe (redundant F-CPU, F-SMs not redundant; system changes to the other F-CPU in case of error)	Enhanced availability
	<ul style="list-style-type: none"> • Redundant switched I/O 	Multi-channel, fail-safe (redundant F-CPU, PROFIBUS DP and F-SMs)	Highest availability

Additional information

For information and examples relating to configuration variants based on availability, refer to the *Safety Engineering in SIMATIC S7* system description.

For detailed information about the safety protector, refer to chapter *Safety protector*.

For detailed information on S7-300 configuration variants, refer to the *S7-300, CPU 31xC and CPU 31x: Installation* manual.

For detailed information on the configuration of ET 200M, refer to the *ET 200M Distributed I/O Device* manual.

For detailed information on using the fail-safe signal modules as redundant I/O in S7 FH systems, refer to the *S7-400H Automation Systems; Fault-Tolerant Systems* manual.

See also

Safe Functional Extra-Low Voltage for Fail-Safe Signal Modules (Page 46)

Configuration and parameter assignment

3.1 Configuring [ID: 431470091]

Requirements

One of the optional packages listed below must be installed for configuring and assigning parameters of fail-safe signal modules in *STEP 7*.

- *S7 Distributed Safety*
- *S7 F/FH Systems*

The following requirements apply to the SM 326; F-DO 10 x DC 24V/2A PP:

- *F Configuration Pack* V5.5 SP 6 HF1 or higher
- For operation together with S7 F Systems
 - *S7 F Systems* V6.0 with *S7 F Systems Lib* V1_3

The following requirements apply to the SM 326; DI 24 x DC 24V, as of order no. 6ES7326-1BK01-0AB0 and the SM 326; DO 8 x DC 24V/2A PM:

- *STEP 7* V5.2 or higher and
- *F Configuration Pack* V5.3 SP 3 or higher

The following requirements apply to SM 336; F-AI 6 x 0/4 ... 20 mA HART:

- *F Configuration Pack* V5.5 SP 4 or higher
- For use in conjunction with S7 F Systems and *with* the HART function:
 - *S7 F Systems* V6.0 with *S7 F Systems Lib* V1_3
 - *STEP 7* V5.4 SP3 + HF3 or higher and *CFC* V6.0 SP2 HF3 or higher
 - *SIMATIC PDM* V6.0 SP3 HF1 or higher + *SIMATIC PDM Devices* V6.0 SP5
 - *EDD* for ET 200M V1.1.9 or higher
 - *PCS 7* V7.0 SP1 or higher + *HF*, including *PCS 7 Library* V7.0 SP2 HF1 or higher
- For use in conjunction with S7 F Systems and *without* the HART function:
 - *S7 F Systems* V6.0 with *S7 F Systems Lib* V1_3
 - *STEP 7* V5.4 SP3 + HF3 or higher and *CFC* V6.0 SP2 HF3 or higher
 - *PCS 7* V7.0 SP1 or higher + *HF*, including *PCS 7 Library* V7.0 SP2 HF1 or higher

3.1 Configuring [ID: 431470091]

- For use in conjunction with S7 Distributed Safety and *with* the HART function:
 - *STEP 7* V5.4 SP 3 +HF3 or higher
 - *SIMATIC PDM* V6.0 SP3 or higher + *SIMATIC PDM Devices* V6.0 SP5
 - *EDD* for ET 200M V1.1.9 or higher
- For use in conjunction with S7 Distributed Safety and *without* the HART function:
 - *STEP 7* V5.4 SP 3 +HF3 or higher

You can download the *F Configuration Pack* from the Internet (<http://support.automation.siemens.com/WW/view/en/15208817>)

Configuring

The fail-safe signal modules are configured as usual, similar to standard modules, using *HW Config*.

Configuration in RUN (CiR)

The SM 326; DI 24 x DC 24 V (as of order no. 6ES7326-1BK01-0AB0) supports configuration in run (CiR) when operated in standard mode (non-safety mode).

Additional information on CiR

For additional information on CiR, refer to:

- In the *STEP 7* online help: "System changes in run using CiR"
- In the *Safety Engineering in SIMATIC S7* system description

Enhanced availability in standard and safety mode

You can enhance availability by means of redundant operation of the F-SMs fail-safe signal modules in **standard mode** (exception: SM 326; DO 8 x DC 24V/2A PM, SM 326; F-DO 10 x DC 24V/2A PP and SM 336; F-AI 6 x 0/4 ... 20 mA HART).

Requirements:

- *STEP 7*V5.3 and higher, or
- *STEP 7*V5.2 or higher, plus optional software package *S7 H Systems* V5.2 or higher

In **safety mode**, you can operate the F-SMs redundantly in **S7 F/FH Systems** F-systems (with the exception of SM 326; DO 8 x DC 24V/2A PM).

Requirements:

- *STEP 7*V5.3 and higher, or
- *STEP 7*V5.2 or higher, plus optional software package *S7 H Systems* V5.2 or higher
- *S7 F Systems* optional software package
- *F Configuration Pack* V5.3 Service Pack 1 or higher
- for SM 326; DI 24 x DC 24V, as of order no. 6ES7326-1BK01-0AB0: *F Configuration Pack* V5.3 Service Pack 3 or higher
- for SM 336; F-AI 6 x 0/4 20 mA HART: *F Configuration Pack* V5.5 Service Pack 4 or higher
- for SM 326; F-DO 10 x DC 24V/2A PP: *F Configuration Pack* V5.5 Service Pack 6 or higher

You can download the *F Configuration Packs* from the Internet (<http://support.automation.siemens.com/WW/view/en/15208817>).

You enhance availability of the modules by assigning the corresponding parameters in the "Redundancy" tab of the object properties dialog for the modules.

3.2 Parameter Assignment [ID: 431472779]

Assigning the module properties

To assign parameters for the fail-safe signal modules, select the module in *STEP 7 HW Config* and then select the **Edit > Object Properties** menu command.

The parameters you download from the programming device to the F-CPU are saved to CPU memory, and are then transferred by the F-CPU to the fail-safe signal module.

Note

SFC 56 "WR_DPARM" (changing module parameters in the user program) is not permitted for fail-safe signal modules.

Parameter description

For information on the assignable parameters of fail-safe modules, refer to the chapters dealing with digital and analog modules.

PROFIsafe address and PROFIsafe address assignment

The description of the PROFIsafe address and of addressing is available in the chapter *Addressing*.

3.3 Firmware update via HW Config [ID: 7869670155]

Introduction

After compatible enhancement of functions, you can now upgrade the following F-SMs to the latest firmware version:

- SM 326; F-DO 10 x DC 24V/2A PP
- SM 336; F-AI 6 x 0/4 ... 20 mA HART

The latest firmware version is available in the Internet

(<http://support.automation.siemens.com/WW/view/en/25536344/133100>).

Requirements

WARNING

Check of the firmware version for F-validity

When using a new firmware version, you must check whether the utilized firmware version is authorized for use in the respective module.

The Appendix of the Certificate indicates which firmware version is authorized.

Note

Make sure that the external auxiliary voltage of the module is switched on before and during the update operation.

- *STEP 7*V5.4 SP3 or higher
- The firmware update can only be performed when the F-CPU/IM is in STOP mode.
- You will have to connect the 24 VDC supply to update the firmware of the F-SM.

Updating firmware

1. Switch the F-CPU/IM to STOP mode.
2. Select the F-SM in *HW Config*.
3. Select the **PLC > Update Firmware** menu command.
4. Use the "Browse" button to select the path to the firmware files (*.upd).
5. Click the "Execute" button.

The module executes the firmware update. During the firmware update, the SF LED flashes at 0.5 Hz.

Note

Display the firmware version of the module to verify that the firmware update was performed on the right module.

You can find additional information in the *STEP 7* online help.

Note

If the firmware update was canceled, an incoming time-out error occurs on the module.

Wait until the module has entered the time-out error as an *outgoing* error.

Then you can perform the firmware update again.

Note

If the SF on the module flashes at 2 Hz, it signals that a firmware update error has occurred.

Perform one of the following actions:

- Switch the power supply of the F-CPU/IM OFF/ON.
- Remove and insert the module.
- Switch the external auxiliary voltage of the module OFF/ON.

Repeat the firmware update.

Note

If the firmware update is cancelled, an incoming and outgoing time-out error can occur.

If only an incoming error is signaled, follow these steps:

- Switch the power supply of the F-CPU/IM OFF/ON.
- Remove and insert the module.
- Switch the external auxiliary voltage of the module OFF/ON.

Contact SIMATIC Customer Support if necessary.

Labeling firmware

After the firmware update, you must label the firmware version on the module.

The firmware version must be visible on the inside of the front door. We recommend that you use the supplied printed labels for this purpose.

3.4 I&M identification data [ID: 6878997259]

Properties

I data: Information about the module that generally appears on the module's housing. I data is only read:

- Hardware release status
- Firmware release status
- Serial number
- MLFB

M data: System-dependent information (e.g. higher level designation of item).

M data is created during configuration.

- Higher level designation of item
- Installation date
- Additional information
- Location designation

Identification data (I&M) is information stored retentively in a module that helps you to:

- Troubleshoot a system
- Check the system configuration
- Locate changes to the hardware of a system.

Reading and writing the I&M data with *STEP 7*

System-dependent information (HID) is configured in the object properties dialog for the module.

You obtain information on the module (I data) from the module status dialog. The system-dependent information (HID) on the module is displayed here too.

Note

Note that when you operate the fail-safe signal modules SM 336; F-AI 6 x 0/4 ... 20 mA HART and SM 326; F-DO 10 x DC 24V/2A PP with the interface module IM153-2 (6ES7153-2BA01-0XB0), you will only be able to write the I&M date "Additional information".

Reading and writing the I&M data with *SIMATIC PDM*

With *SIMATIC PDM*, you can read the parameters and I&M data by choosing the **File > Complete Download to PG/PC** menu command and write them by choosing the **Device > Complete Download to Device** menu command.

Addressing and installation

4.1 Address Assignments in the CPU [ID: 431552779]

Address assignment in standard and safety mode

The fail-safe signal modules occupy the following address ranges in the CPU/F-CPU:

- In standard mode: The full I/O area (within and outside the process image)
- In safety mode for *S7 Distributed Safety* and for *S7 F/FH Systems* in the area of the process image

Table 4- 1 Address assignment in standard and safety mode

Module	Bytes occupied in the CPU:	
	In the input area	In the output area
SM 326; DI 24 x DC 24 V	x + 0 to x + 9	x + 0 to x + 3
SM 326; DI 8 x NAMUR	x + 0 to x + 5	x + 0 to x + 3
SM 326; DO 8 x DC 24V/2A PM	x + 0 to x + 4	x + 0 to x + 4
SM 326; DO 10 x DC 24V/2A	x + 0 to x + 5	x + 0 to x + 7
SM 326; F-DO 10 x DC 24V/2A PP	x + 0 to x + 5	x + 0 to x + 7
SM 336; AI 6 x 13Bit	x + 0 to x + 15	x + 0 to x + 3
SM 336; F-AI 6 x 0/4 ... 20 mA HART	x + 0 to x + 15	x + 0 to x + 3
x = module start address		

Address assignment of user data

Of the assigned addresses in standard and safety mode of the F-SMs, the user data occupy the following addresses in the CPU/F-CPU.

Table 4- 2 Address assignment of user data

Bytes in the CPU	Assigned bits in the CPU for each module:							
	7	6	5	4	3	2	1	0
SM 326; DI 24 x DC 24 V:								
x + 0	Channel 7	Channel 6	Channel 5	Channel 4	Channel 3	Channel 2	Channel 1	Channel 0
x + 1	Channel 15	Channel 14	Channel 13	Channel 12	Channel 11	Channel 10	Channel 9	Channel 8
x + 2	Channel 23	Channel 22	Channel 21	Channel 20	Channel 19	Channel 18	Channel 17	Channel 16
SM 326; DI 8 x NAMUR:								
x + 0	Channel 7	Channel 6	Channel 5	Channel 4	Channel 3	Channel 2	Channel 1	Channel 0

4.1 Address Assignments in the CPU [ID: 431552779]

Bytes in the CPU	Assigned bits in the CPU for each module:							
	7	6	5	4	3	2	1	0
SM 326; DO 8 x DC 24V/2A PM:								
x + 0	Channel 7	Channel 6	Channel 5	Channel 4	Channel 3	Channel 2	Channel 1	Channel 0
SM 326; DO 10 x DC 24V/2A and SM 326; F-DO 10 x DC 24V/2A PP:								
x + 0	Channel 7	Channel 6	Channel 5	Channel 4	Channel 3	Channel 2	Channel 1	Channel 0
x + 1	—	—	—	—	—	—	Channel 9	Channel 8
SM 336; AI 6 x 13Bit:								
x + 0, x + 1	Channel 0							
x + 2, x + 3	Channel 1							
x + 4, x + 5	Channel 2							
x + 6, x + 7	Channel 3							
x + 8, x + 9	Channel 4							
x + 10, x + 11	Channel 5							
SM 336; F-AI 6 x 0/4 ... 20 mA HART:								
x + 0, x + 1	Channel 0							
x + 2, x + 3	Channel 1							
x + 4, x + 5	Channel 2							
x + 6, x + 7	Channel 3							
x + 8, x + 9	Channel 4							
x + 10, x + 11	Channel 5							
x = module start address								

 **WARNING**

You may only access the addresses occupied by the user data both in the standard user program and the safety program. Other address areas occupied by the F-SMs are assigned, for example, for safety-oriented communication between the F-SMs and the F-CPU in accordance with PROFIsafe.

With 1oo2 sensor evaluation of modules in safety mode, you may access only the lower order channel of the channels combined by the 1oo2 sensor evaluation.

4.2 Addressing the Channels [ID: 431555467]

Addresses of fail-safe signal modules

The channels of fail-safe signal modules are addressed similar to S7-300 standard I/O modules.

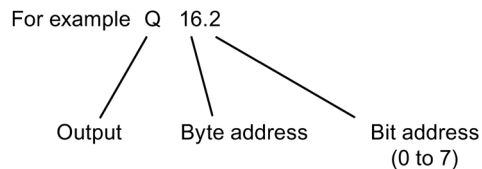

The byte address is derived from the module start address set in the object properties of the module in *STEP 7 HW Config*. The bit address is derived from the channel's position at the module. A byte address is always assigned eight channels in successive order.

Address space allowed for use in standard mode

Address space allowed for the byte address:

- *S7 Distributed Safety* and *S7 F/FH Systems*: the entire I/O area (within and outside the process image), depending on the CPU used

For the SM 326; DI 24 x DC 24 V (order no. 6ES7326-1BK00-0AB0),

SM 326; DI 8 x NAMUR, SM 326 DO 10 x DC 24V/2A and

SM 336; AI 6 x 13 Bit also applies: 8 to 8184 in increments of 8.

Address space allowed for use in safety mode

Address space allowed for the byte address:

- *S7 Distributed Safety*: within the area of the process image, depending on the F-CPU used

For the SM 326; DI 24 x DC 24 V (order no. 6ES7326-1BK00-0AB0),

SM 326; DI 8 x NAMUR, SM 326 DO 10 x DC 24V/2A and

SM 336; AI 6 x 13 Bit also applies: 8 to 8184 in increments of 8.

- *S7 F/FH Systems*: within the area of the process image, depending on the F-CPU used

For the SM 326; DI 24 x DC 24 V (order no. 6ES7326-1BK00-0AB0),

SM 326; DI 8 x NAMUR, SM 326 DO 10 x DC 24V/2A and

SM 336; AI 6 x 13 Bit also applies: 8 to 8184 in increments of 8.

Accessing channels of F-SMs operating in standard mode

Channels of the F-SMs are accessed similar to the channels of S7-300 standard I/O modules.

Accessing channels of F-SMs operating in safety mode

The F-I/O channels are accessed in *S7 Distributed Safety* by means of the process image in the F-CPU; in *S7 F/FH Systems* you access these using fail-safe driver blocks.

Additional information

The address space allocated to the various channels is included in the module description, in the chapters dealing with digital and analog modules.

For detailed information on F-I/O access, refer to the *S7 Distributed Safety, Configuring and Programming* or to the *S7 F/FH Systems Configuring and Programming* manual.

4.3 Assigning the PROFIsafe address

4.3.1 Introduction [ID: 431542795]

PROFIsafe address

Each fail-safe signal module is assigned a unique PROFIsafe address. Configure the PROFIsafe address for safety mode using *HW Config* and the selection switch on the module.

Overview: Assigning the PROFIsafe address

You have two options of assigning the PROFIsafe address to the F-SMs for operation in safety mode, depending on the module. These two addressing options are described in separate chapters.

Table 4- 3 Overview: Assigning the PROFIsafe address

Module	Assigning the PROFIsafe address (starting address of F-SM)	Assigning the PROFIsafe address (F_destination_address)
SM 326; DI 24 x DC 24 V 6ES7326-1BK00-0AB0	x	—
SM 326; DI 24 x DC 24 V ab 6ES7326-1BK01-0AB0	—	x
SM 326; DI 8 x NAMUR	x	—
SM 326; DO 8 x DC 24V/2A PM	—	x
SM 326; DO 10 x DC 24V/2A	x	—
SM 326; F-DO 10 x DC 24V/2A PP	—	x
SM 336; AI 6 x 13 Bit	x	—
SM 336; F-AI 6 x 0/4 ... 20 mA HART	—	x

4.3.2 Assigning PROFIsafe Address (Starting Address of F-SM) [ID: 431545227]

Introduction

In order to use

- SM 326; DI 24 x DC 24 V (order no. 6ES7326-1BK00-0AB0),
- SM 326; DI 8 x NAMUR,
- SM 326; DO 10 x DC 24V/2A and the
- SM 336; AI 6 x 13 Bit

in safety mode, you must perform the following steps:

1. Set the module start address
2. Set safety mode
3. Set the start address of the fail-safe signal module at the address switch before you install it

Setting the module start address

You set the module start address similar to S7-300 standard I/O modules in the object properties of the module using *STEP 7 HW Config* (for information on the permitted address space, refer to the *Channel addressing* chapter).

Setting safety mode

Set "Safety mode" in the object properties of the module in *HW Config*.

Address switch

The 10-bit DIP switch for addressing is installed in the rear panel of the fail-safe signal modules. This switch is used to determine:

- whether to operate the module in safety mode or in standard mode
- In safety mode: the module start address (PROFIsafe address = start address/8 of the F-SM)

The F-SMs are set by default for operation in "standard mode", that is, all switches are in up position. Alternatively, you can set all switches to down position. See figure below.

Setting the address switch

Verify the correct setting of the address switch **before you start installation**.

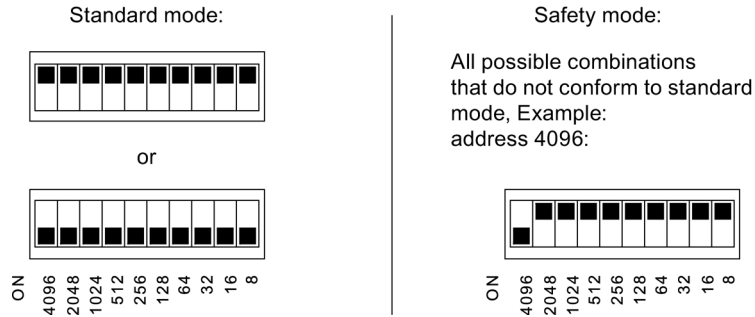

Figure 4-1 Example of address switch (DIP switch) settings

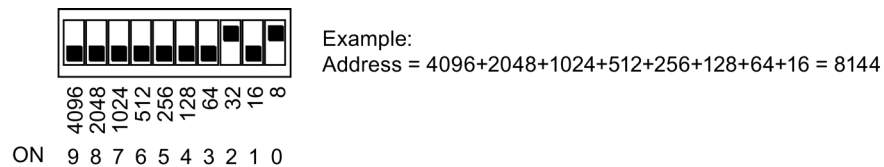

Figure 4-2 Example for calculation of the start address

Note

An address switch of the smallest possible dimensions is installed for reasons of space saving. This makes it sensitive to pressure and objects with sharp edges. Always use a suitable tool to manipulate the address switch.

A variety of tools suitable for activating the address switch are available on the market, for example, the Grayhill DIPSTICK. A ballpoint pen may be employed if used carefully. It is imperative to avoid any burring that would prevent the switch from reaching its home position. Do not use screwdrivers or knives to manipulate the address switch.

Addressing rules

WARNING

Rule for PROFIBUS subnets:

The PROFIsafe destination address and, thus, the switch setting on the address switch of the F-I/O must be unique network-wide* and station-wide** (system-wide). For S7-300 F-SMs and ET 200S, ET 200eco and ET 200pro F-modules, you can assign a maximum of 1022 different PROFIsafe destination addresses.

Exception: The F-I/O in different I-slaves may be assigned the same PROFIsafe destination address, as they are only addressed within the station, that is, by the F-CPU in the I-slave.

Rules for Ethernet subnets and hybrid configurations of PROFIBUS and Ethernet subnets:

The PROFIsafe destination address and, thus, the address switch setting on the F-I/O have to be unique only*** within the Ethernet subnet, including all lower-level PROFIBUS subnets, and station-wide** (system-wide). For S7-300 F-SMs and ET 200S, ET 200eco and ET 200pro F-modules, you can assign a maximum of 1022 different PROFIsafe destination addresses.

Exception: The F-I/O in different I-slaves may be assigned the same PROFIsafe destination address, as they are only addressed within the station, that is, by the F-CPU in the I-slave.

The networked nodes of an Ethernet subnet are characterized by having IP addresses with the same subnet address, which means the IP addresses match in the digits that have the value "1" in the subnet mask.

Example:

IP address: 140.80.0.2.

Subnet mask: 255.255.0.0 = 11111111.11111111.00000000.00000000

Meaning: Bytes 1 and 2 of the IP address define the subnet; subnet address = 140.80.

* A network consists of one or several subnets. "Network-wide" means beyond the boundaries of the subnet.

** "Station-wide" means for one station in *HW Config* (for example, an S7-300 station or I-slave)

*** Across Ethernet subnets, excluding cyclic PROFINET IO communication (RT communication)

Address inconsistency

A parameter assignment error is generated if addressing is inconsistent, for example, if the module address differs from the address set in *HW Config*. The module does not enter safety mode.

See also

Addressing the Channels (Page 35)

4.3.3 Assigning PROFIsafe Address (F_destination_address) [ID: 431547659]

Introduction

In order to use

- SM 326; DI 24 x DC 24V (as of order no. 6ES7326-1BK01-0AB0),
- SM 326; DO 8 x DC 24V/2A PM,
- SM 326; F-DO 10 x DC 24V/2A PP and the
- SM 336; F-AI 6 x 0/4 ... 20 mA HART

in safety mode, you must perform the following steps:

1. setting the operating mode "Safety mode" for the SM 326; DI 24 x DC 24V
2. Set the PROFIsafe address = F_destination_address using the address switch before you install the fail-safe signal module.

By contrast to the PROFIsafe address setting, which is based on the start address, there is no correlation between the module start address and the PROFIsafe address for the modules mentioned earlier. You set the module start address in the object properties of the module similar to the addressing of S7-300 standard I/O modules in *STEP 7 HW Config*.

Setting safety mode

Set "Safety mode" in the object properties of the module in SM 326; DI 24 x DC 24V (as of order no. 6ES7326-1BK01-0AB0) in *HW Config*.

The SM 326; DO 8 x DC 24V/2A PM, SM 326; F-DO 10 x DC 24V/2A PP and SM 336; F-AI 6 x 0/4 ... 20 mA HART operate in safety mode only. This module is set up permanently for operation in "safety mode".

Assigning PROFIsafe addresses

The PROFIsafe addresses (F_source_address, F_destination_address) are assigned automatically to the two F-SMs mentioned earlier when you configure these modules in *STEP 7*. The F_destination_addresses of the FMs are shown in their object properties in *HW Config* and are returned in binary format at the "DIP switch setting" parameters.

You can edit the configured F_destination_address in *HW Config*. It is advisable, however, to use the F_destination_address which is assigned automatically.

Address switch

The 10-bit DIP switch for addressing is installed in the rear panel of the fail-safe signal modules. This switch is used to determine:

- whether to operate the module in safety mode or in standard mode
- In safety mode: the PROFIsafe address = F_destination_address.

The SM 326; DI 24 x DC 24V is set by default for operation in "standard mode" (all switches are in up position, but you can set all switches to down position, see figure below).

The SM 336; F-AI 6 x 0/4 ... 20 mA HART, SM 326; F-DO 10 x DC 24V/2A PP and SM 326; DO 8 x DC 24V/2A PM will be supplied with a PROFIsafe address of 1 to 1022, which means "safety mode". You can change this, as shown in the figure below.

Setting the address switch

Verify the correct setting of the address switch *before you start installation*.

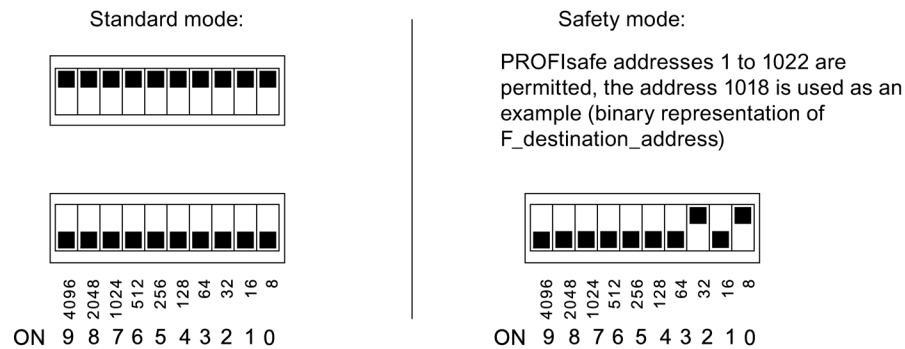

Figure 4-3 Example of address switch (DIP switch) settings

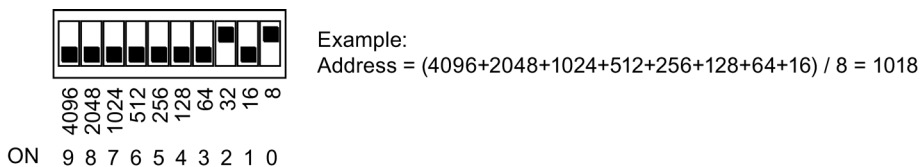



Figure 4-4 Example for calculation of the F_destination_address

Note

An address switch of the smallest possible dimensions is installed for reasons of space saving. This makes it sensitive to pressure and objects with sharp edges. Always use a suitable tool to manipulate the address switch.

A variety of tools suitable for activating the address switch are available on the market, for example, the Grayhill DIPSTICK. A ballpoint pen may be employed if used carefully. It is imperative to avoid any burring that would prevent the switch from reaching its home position. Do not use screwdrivers or knives to manipulate the address switch.

Addressing rules

<p> WARNING</p> <p>Rule for PROFIBUS subnets:</p> <p>The PROFIsafe destination address and, thus, the switch setting on the address switch of the F-I/O must be unique network-wide* and station-wide** (system-wide). For S7-300 F-SMs and ET 200S, ET 200eco and ET 200pro F-modules, you can assign a maximum of 1022 different PROFIsafe destination addresses.</p> <p>Exception: The F-I/O in different I-slaves may be assigned the same PROFIsafe destination address, as they are only addressed within the station, that is, by the F-CPU in the I-slave.</p> <p>Rules for Ethernet subnets and hybrid configurations of PROFIBUS and Ethernet subnets:</p> <p>The PROFIsafe destination address and, thus, the address switch setting on the F-I/O have to be unique only*** within the Ethernet subnet, including all lower-level PROFIBUS subnets, and station-wide** (system-wide). For S7-300 F-SMs and ET 200S, ET 200eco and ET 200pro F-modules, you can assign a maximum of 1022 different PROFIsafe destination addresses.</p> <p>Exception: The F-I/O in different I-slaves may be assigned the same PROFIsafe destination address, as they are only addressed within the station, that is, by the F-CPU in the I-slave.</p> <p>The networked nodes of an Ethernet subnet are characterized by having IP addresses with the same subnet address, which means the IP addresses match in those digits that have the value "1" in the subnet mask.</p> <p>Example:</p> <p>IP address: 140.80.0.2</p> <p>Subnet mask: 255.255.0.0 = 11111111.11111111.00000000.00000000</p> <p>Meaning: Bytes 1 and 2 of the IP address define the subnet; subnet address = 140.80</p>
--

* A network consists of one or several subnets. "Network-wide" means beyond the boundaries of the subnet.

** "Station-wide" means for one station in *HW Config* (for example, an S7-300 station or I-slave)

*** Across Ethernet subnets, excluding cyclic PROFINET IO communication (RT communication)

Address inconsistency

A parameter assignment error is generated if addressing is inconsistent, for example, if the module address differs from the address set in *HW Config*. The module does not enter safety mode.

See also

Assigning PROFIsafe Address (Starting Address of F-SM) (Page 38)

4.4 Installing [ID: 431550091]

Installing fail-safe signal modules

The fail-safe signal modules belong to the S7-300 family and support central operation in S7-300 and distributed operation in the ET 200M Distributed I/O Device.

The fail-safe signal modules are installed in an S7-300 or ET 200M similar to any other S7-300 signal module.

For further information, refer to the *S7-300, CPU 31xC and CPU 31x: Installation* installation manual, or to the *ET 200M Distributed I/O Device* manual.

Redundant configuration of ET 200M

Note

All redundant systems with integrated ET 200M *must* be installed in a control cabinet which provides adequate attenuation functions for limiting RF interference (see chapter "Electromagnetic Compatibility (Page 66)").

This is not necessary when you use an IM153-2 as of 6ES7153-2BA02-0XB0.

[ID: 431574027]

 **WARNING**

It is strictly forbidden to override any safety functions or to take any measures to this effect, as this would lead to serious risk of injury and of damage to the environment. The manufacturer shall not be liable for any consequential damage incurred as a result of such manipulation, or for material or immaterial damage which may be caused if this warning is ignored.

Note

The maximum cable lengths currently specified in this manual ensure against functional impairment, even without more precise examination of the boundary conditions. However, you must comply with the specifications in the documentation.

If the boundary conditions, such as EMC, cable type, cable routing, etc., are examined more precisely, longer cables can be used for all F-SMs.

In this chapter

This chapter contains information about:

- Operation of F-SMs with PELV
- Special features in terms of F-SM wiring
- Special features in terms of the replacement of F-SMs

Additional information

For information about the wiring rules for fail-safe and standard signal modules, refer to the S7-300 Automation System, Hardware and Installation: *CPU 31xC and CPU 31x: Installation manual*.

5.1 Safe Functional Extra-Low Voltage for Fail-Safe Signal Modules [ID: 431563275]

PELV

 WARNING

Fail-safe signal modules must be operated with safe functional extra low voltage (SELV, PELV). That is, the fail-safe modules may only be exposed to a maximum fault voltage of V_m . Rule for all fail-safe signal modules:

$$V_m < 60.0 \text{ V}$$

Additional information about PELV is available in the data sheets of the power supply modules to be installed, for example.

All system components which supply electrical power in any form must meet this condition.

Each additional power circuit (24 V DC) installed in the system must be operated with safe functional extra low voltage (SELV, PELV). Refer to the data sheets or contact the manufacturer for information.

You should also note that the sensors and actuators connected to the I/O modules may be connected to an auxiliary power supply. Make sure that such auxiliary power supplies conform to PELV requirements. The process signal of a 24 V digital module may not develop a fault voltage in excess of V_m .

 WARNING

All power sources such as the internal and external 24 V DC load voltage supplies, and the 5 VDC bus voltage must be galvanically interconnected so that any development of cumulative voltage at the individual voltage sources which may lead to a fault voltage higher than V_m is safely ruled, irrespective of any potential differences.

Make sure that the conductor cross-sections used for the galvanic interconnections are compliant with S7-300 installation guidelines (see the *S7-300 Automation System: CPU 31xC and CPU 31x: installation* Operating Instructions).

The fail-safe signal modules and all their standard components can be operated in standard and safety mode on a single or on several shared power supply modules.

Power supply requirements for compliance with the NAMUR recommendation

Note

Always use power supply modules/units (230 V AC → 24 V DC) with integrated function for power failure backup for the duration of at least 20 ms in accordance with NAMUR recommendation NE 21, IEC 61131-2, and EN 298. Power supply components available (examples):

S7-400

- 6ES7407-0KA01-0AA0 for 10 A
- 6ES7407-0KR00-0AA0 for 10 A

S7-300

- 6ES7307-1BA00-0AA0 for 2 A
- 6ES7307-1EA00-0AA0 for 5 A
- 6ES7307-1KA00-0AA0 for 10 A

These requirements, of course, also apply to power supply modules/units which are not produced according to S7-300/400 installation technology.

5.2 Wiring Fail-Safe Signal Modules [ID: 431565963]

Wiring similar to standard signal modules

The fail-safe signal modules belong to the S7-300 module family and are wired similar to any standard signal module in the S7-300 or ET 200M system.

For further information on the wiring of fail-safe signal modules, refer to the *S7-300, CPU 31xC and CPU 31x: Installation* Operating Instructions.

The information in the module chapters includes special features to observe when wiring specific F-SMs and the wiring diagrams for various applications with F-SMs.



WARNING

Note the following when assigning signals of fail-safe digital input modules:

- Do not route signals within the same cable or light plastic-sheathed cable if their short circuit could conceal a serious safety risk.
- Only route signals within the same cable or light plastic-sheathed cable that are supplied by different sensor supplies of this F-DI module.

Front connector versions

Use the 40-pin front connector to wire the fail-safe signal modules. The 40-pin or 20-pin front connector is available in three versions:

- Cage-clamp technology
- Screw-type technology
- Fast Connect technology

For order numbers, see chapter "Accessories and Order Numbers (Page 341)".

For information about cables which may be used to wire the 40-pin front connector, refer to the *S7-300, CPU 31xC and CPU 31x: Installation* manual.

5.3 Replacing Fail-Safe Signal Modules [ID: 431568651]

Inserting and removing F-SMs in standard mode

Fail-safe signal modules can be inserted and removed at the S7-300 and ET 200M similar to any standard signal module.

An ET 200M configuration with *active bus modules* supports hot-swapping of the F-SMs during operation of ET 200M.

Inserting and removing F-SMs in safety mode

Fail-safe signal modules can be inserted and removed at the S7-300 and ET 200M similar to any standard signal module.

An ET 200M configuration with *active bus modules* supports hot-swapping of the F-SMs. A special bus module is required to interconnect a safety protector with the backplane bus (order no. see chapter "Accessories and Order Numbers (Page 341)").

Any module replacement generates an error in safety-oriented communication between the F-CPU and the replaced F-SM when operating in safety mode, regardless of whether or not active bus modules are being used.

For more information regarding the effects of communication errors, refer to the *S7 Distributed Safety Configuring and Programming* or *S7 F/FH Systems Configuring and Programming* manual.

 WARNING
--

The safety protector may not be inserted or removed while the system is in operation! (Any insertion or removal would inevitably lead to failure of the ET 200M.)

Observe the address settings when replacing modules in safety mode

Make sure that the address switch (DIP switch) on the rear panel of the replaced F-SM has the same setting!

Additional information

The configuration with safety protector on the active backplane bus is described in the chapter "Safety protector (Page 321)".

For information on module replacement in an S7-300 AS, refer to the *S7-300 Automation System, Installation* manual.

For information on module replacement and the "hot-swapping" function at an ET 200M, refer to the *ET 200M Distributed I/O Device* manual.

See also

Configuration Variants (Page 323)

5.4 Sensor and Actuator Requirements for F-SMs in Safety Mode [ID: 431571339]

General sensor and actuator requirements

Note the following warning in terms of safety-oriented operation of sensors and actuators:

 WARNING
<p>Instrumentation using sensors and actuators poses considerable <i>safety responsibility</i>. Note that sensors and actuators generally do not withstand a proof-test interval of 10 years according to the IEC 61508:2000 standard without considerable safety degradation.</p> <p>A safety function must comply in terms of the probability and rate of hazardous faults with limits determined by the safety integrity level (SIL). The values achieved by the F-SMs are listed in the "Fail-safe performance characteristics" section of their technical specifications in the corresponding sections.</p> <p>To achieve the respective Safety Integrity Level, suitably qualified sensors and actuators are necessary.</p>

Additional sensor requirements

General rule: A one-channel sensor is sufficient to achieve SIL 2/Cat. 3/PLd; to achieve SIL 3/Cat. 4/PLe, sensors must be connected via two channels. To achieve SIL 2/Cat. 3/PLd with a one-channel sensor, the sensor itself must be SIL 2/Cat. 3/PLd-capable; otherwise, sensors must be connected via two channels to achieve this safety level.

Additional requirements for sensors and NAMUR sensors

 WARNING
<p>A "0" value is output to the F-CPU when faults are detected at the fail-safe input modules. Ensure that the "0" state of the sensors triggers a reliable response in the safety program.</p> <p>Example: The safety program of an EMERGENCY-OFF sensor must trigger "0" state at the corresponding actuator (EMERGENCY-OFF button pressed).</p> <p>The time interval between two signal transitions (pulse duration) must be greater than the PROFIsafe monitoring time to allow reliable detection of the pulses.</p>

Requirements for the duration of sensor signals for the SM 326; DI 24 x DC 24V

 WARNING
In order to guarantee accurate detection of sensor signals by the SM 326; DI 24 x DC 24V, you must ensure that the sensor signals have a defined minimum duration.

Reliable detection with the SM 326; DI 24 x DC 24V

The minimum duration of sensor signals required for reliable detection by the SM 326; DI 24 x DC 24V depends on the short-circuit test parameter assignment in *STEP 7*.

Table 5- 1 Minimum duration of sensor signals for proper detection by an SM 326; DI 24 x DC 24V

Short-circuit test parameter	Minimum duration of sensor signals
Deactivated	25 ms
Activated	30 ms

Reliable detection in the safety program of the F-CPU

For information in terms of the reliable detection of sensor signals in the safety program, refer to the the *Safety Engineering in SIMATIC S7* system description.

Additional requirements of actuators

The fail-safe output modules perform a cyclic test of the outputs. The module briefly disables the activate outputs and enables the inactive outputs. The test pulses have the following duration:

- Dark period < 1 ms
- Light period < 1 ms

You can configure a light and dark period for the SM 326; F-DO 10 x DC 24V/2A PP. You can find additional information in the SM 326; F-DO 10 x DC 24V/2A PP online help.

High-speed actuators may briefly drop out or be activated during this test. If your process does not tolerate this action you must use actuators with a sufficient lag (> 1 ms).

 **WARNING**

The outputs of a fail-safe output module must be electrically isolated to EN 50178 from components which carry higher voltages if the actuators are operated at voltages higher than 24 V DC, for example, at 230 V DC, or are being used to switch higher voltages.

Relays and contactors usually comply with this rule. This aspect is of particular importance when using semiconductor switchgear.

Avoiding dark periods when operating in safety mode

 **WARNING**

If you are using actuators that respond too fast (i.e. < 1 ms) to "dark period" test signals, you can nonetheless use the internal test coordination by wiring two opposite outputs in parallel using a series diode. Parallel wiring suppresses the dark periods at the actuator (see section "Parallel Connection of Two Outputs for Dark Period Suppression (Page 159)").

Technical specifications of sensors and actuators

Refer to the module sections which contain the technical specifications for selecting sensors and actuators.

Fault reaction and diagnostics

6.1 Fault reactions of the F-SMs

6.1.1 Reactions to Faults in Standard Mode [ID: 431586955]

Fault reactions

Fail-safe signal modules react to faults similar to standard modules in S7-300 or ET 200M when operated in standard mode. You can react to a fault or interrupt event either by setting a CPU STOP, or by calling an error OB or interrupt OB in the user program (see *S7-300 Automation System: CPU 31xC and CPU 31x: installation* Operating Instructions).

Fail-safe values

Fail-safe values can be assigned and are output by the fail-safe modules to the process, for example, when:

- the CPU goes into STOP, or when a CP operated as DP master goes into STOP
- an IM 153-2/-2 FO (ET 200M) goes into STOP
- PROFIBUS DP is interrupted
- Interruption of PROFINET IO

Output of fail-safe values at the output modules

Fail-safe digital output modules operated in standard mode support the fail-safe values "0", "1", or "hold last value". You assign the required fail-safe value in the object properties dialog for the F-SM in *HW Config* (refer to the chapter *Digital modules*).

See also

Diagnostic messages of SM 326; DO 8 x DC 24V/2A PM (Page 140)

Diagnostic Messages for SM 326; DI 8 x NAMUR (Page 127)

Diagnostic messages of SM 326; DI 24 x DC 24V (Page 105)

Diagnostics messages of SM 326; DO 10 x DC 24V/2A (Page 160)

Diagnostic Messages for SM 336; AI 6 x 13 Bit (Page 232)

6.1.2 Fault reactions in safety mode [ID: 431589387]

Safe state (safety concept)

The safety concept is based on the existence of a safe state at all process variables.

Note

For digital signal modules, this safe state is the value "0". This applies to sensors and actuators.

Fault reactions and startup of the F-System

The safety function requires the use of fail-safe values (safe state) instead of process values for a fail-safe signal module (**passivation of fail-safe signal module**) in the following cases:

- During startup of the F-system
- When errors in safety-oriented communication between the F-CPU and F-SM are detected by means of the PROFIsafe safety protocol (communication error)
- When F-I/O or channel faults are detected, for example, wire break, short-circuit, or discrepancy error

Faults are logged to the diagnostic buffers of the F-SM and of the CPU, and reported to the safety program in the F-CPU.

WARNING

When assigning parameters for the F-SMs listed below in the object properties for the F-SM in *HW Config*, do not forget to enable group diagnostics for each channel for the response to channel errors, (refer to the corresponding sections *Digital modules* and *Analog module*):

- SM 326; DI 8 x NAMUR
- SM 326; DO 10 x DC 24V/2A
- SM 336; AI 6 x 13Bit

Output of fail-safe values for fail-safe signal modules

When fail-safe input modules are passivated, the F-System returns fail-safe values instead of the process values set at the fail-safe inputs to the user program:

- In *S7 Distributed Safety* F-systems: Fail-safe value "0" is always output for fail-safe digital input and analog input modules.
- In *S7 F/FH Systems* F-systems: Fail-safe value "0" is returned to the fail-safe digital input modules. You can assign the fail-safe value in the safety program (in the F-channel driver) for fail-safe analog input modules.

When fail-safe output modules are passivated, the F-system returns fail-safe value "0" to the fail-safe outputs instead of the output values provided by the safety program. The output channels are powered down. This also applies when the F-CPU goes into STOP. Configuration with substitute values is not possible.

Fail-safe values are used only for the affected channel or for all channels of the relevant fail-safe signal module, depending on the configuration and the type of fault (F-I/O fault, channel fault, or communication error).

Reaction of the SM 326; F-DO 10 x DC 24V/2A PP to CPU Stop

Depending on the parameter "Reaction to CPU Stop", the SM 326; F-DO 10 x DC 24V/2A PP will behave according to the following standards:

Parameter setting "Reaction to CPU Stop"	
Switch to fail-safe value "0"	Keep last valid value
<p>Compliance with all standards listed in the certificates. The certificates are available in the Internet at:</p> <ul style="list-style-type: none"> • Certificate for S7 Distributed Safety (http://support.automation.siemens.com/WW/view/en/11669702/134200) • Certificate for S7 F/FH systems (http://support.automation.siemens.com/WW/view/en/13711209/134200) 	<p>Only compliant with:</p> <ul style="list-style-type: none"> • NFPA72 • EN54-2 /-4

Reintegration of fail-safe signal modules

The changeover from fail-safe values to process values (reintegration of an F-SM) is executed either automatically or in the safety program after user acknowledgment. After a reintegration:

- For a fail-safe input module, the process values pending at the fail-safe inputs are made available to the safety program again
- For a fail-safe output module, the output values made available in the safety program are again transferred to the fail-safe outputs

Additional information on passivation and reintegration

For additional information on passivation and reintegration of F-I/O, refer to the S7 Distributed Safety Configuring and Programming (<http://support.automation.siemens.com/WW/view/en/22099875>) or S7 F/FH Configuring and Programming (<http://support.automation.siemens.com/WW/view/en/16537972>) manual.

Disabling group diagnostics

The "Group diagnostics" parameter is used to enable and disable the transfer of channel-specific diagnostic messages (for example, wire break, short-circuit) of the module to the CPU. For reasons of availability, you should disable group diagnostics at *unused* input or output channels of the F-SMs listed below:

- SM 326; DI 8 x NAMUR
- SM 326; DO 10 x DC 24V/2A
- SM 336; AI 6 x 13 Bit

WARNING

Group diagnostics must be enabled at *all connected channels* of fail-safe input and output modules which operate in safety mode.

Verify that group diagnostics is only disabled at unused input and output channels.

Diagnostic interrupts can be enabled optionally.

The following applies for **SM 326; DI 24 x DC 24V, SM 326; DO 8 x DC 24V/2A PM, SM 326; F-DO 10 x DC 24V/2A PP and SM 336; F-AI 6 x 0/4 ... 20 mA HART:**

By disabling a channel in *HW Config* you also disable its group diagnostics function.

6.1.3 Fault reactions in safety mode with parameter setting "Keep last valid value" [ID: 16215132811]

Applications

Typical applications for safety mode with parameter setting "Keep last valid value" are:

- Ventilation systems
- Smoke flaps

Fault reactions

Note

Consult the respective standards for installation.

Note

Only standards EN54-2 /-4 or NFPA72 will be met with parameter setting "Keep last valid value".

The last valid value will be retained in case of the following communication errors/interruptions:

- STOP of F-CPU (interruption of PROFIsafe communication)
- Interruption of PROFIsafe communication
 - in case of CRC errors
 - Interruption of PROFIBUS/PROFINET connection
 - Timeout of data frame monitoring
- Error in safety program of the F-CPU
- Error in PROFIsafe protocol

The current process value will be issued again once PROFIsafe communication resumes.

The safe status "0" will be assumed at the digital output module in case of the following errors:

- Channel errors (independent of parameter "Behavior after channel faults")
- Module faults

With a pending channel fault in connection with *S7 Distributed Safety*, the last valid value of all error-free channels will be retained after a STOP-RUN transition of the F-CPU until reintegration. You will have to correct the channel fault before reintegration if the parameter "Behavior after channel fault" is set to "Passivate the entire module".

To increase availability use application 6 of the SM 326; F-DO 10 x DC 24V/2A PP.

6.2 Diagnosis of Faults of F-SMs [ID: 431591819]

Definition

The diagnostics functions can be used to identify signal detection errors at the fail-safe signal modules. Diagnostics information is assigned either to a channel or to the entire module.

Diagnostics functions are not safety-sensitive

Diagnostics functions (displays and messages) are not implemented with safety-oriented characteristics, as these are not safety-relevant. That is, the diagnostics functions are not tested internally.

Diagnostics features for fail-safe signal modules

Diagnostics functions for fail-safe signal modules:

- LED display on the front panel
- Diagnostic messages of the fail-safe signal modules

Programmable and non-programmable diagnostic messages

A distinction is made between assignable and nonassignable diagnostic messages in terms of diagnostics data evaluation.

 WARNING
--

Diagnostics functions should be enabled or disabled to suit application requirements.

Diagnostics using the LED display

Diagnostic messages are always indicated at the SF LED (group error LED). The SF LED is activated when the F-SM generates a diagnostic message. It is deactivated again after all faults/errors have been cleared.

Restraints of the F-SMs listed below:

- SM 326; DI 8 x NAMUR
- SM 326; DO 10 x DC 24V/2A
- SM 336; AI 6 x 13Bit

Assignable diagnostic messages (for example, wire break or short circuit) only activate the SF LED if diagnostics is enabled at the "Group diagnostics" parameter in the object properties dialog of the F-SM in *HW Config* (see chapters for *Digital modules* and *Analog module*).

Diagnostics LEDs of the F-SMs

LED	Safety mode		Standard mode	
	Channel or module fault	Defective module	Channel or module fault	Defective module
SF (red)	On	On	On	On
SAFE (green)	On	Off	Off	Off

The following applies to the SM 326; DI 24 x DC 24V, SM 326; DO 8 x DC 24V/2A PM, SM 326; F-DO 10 x DC 24V/2A PP and SM 336; F-AI 6 x 0/4 ... 20 mA HART: a flashing of the SF-LED in safety mode means a request for depassivation.

Additional LEDs are described in the chapters of the respective modules.

Diagnostic interrupt

The fail-safe signal modules trigger a diagnostic interrupt when a fault is detected (for example, a short circuit), provided this diagnostic interrupt is enabled. The F-CPU interrupts execution of the user program (standard or safety) or of the lower priority classes and executes diagnostic interrupt OB82.

Assigning the diagnostic interrupt enable parameter

The diagnostic interrupt is disabled by default. Enable the diagnostic interrupt in the object properties dialog of the F-SM in *HW Config*, (see chapters for Digital modules (Page 75) and Analog modules (Page 193)).

Special information regarding diagnostic messages

All module-specific diagnostic messages, their possible causes, and corresponding corrective measures are described in the module chapters.

These chapters also define which diagnostic messages must be assigned, and which are displayed on a channel-specific basis.

Reading diagnostic messages

Use *STEP 7* to read the cause of the problem

- From the diagnostic buffer of the CPU or the diagnostic buffer of the module (*STEP 7* function "Diagnose Hardware").
- In the standard user program by calling SFC59 (see Appendix *Diagnostic data of signal modules* and the System and Standard Functions reference manual).

General technical data

7.1 Introduction [ID: 431480587]

Definition

General technical data include:

- The standards and test values that the fail-safe signal modules comply with or fulfill when operated in an S7-300/ET 200M
- the test criteria for fail-safe signal modules.

7.2 Standards and Approvals [ID: 54277212555]

CE approval



Siemens products meet requirements and the safety objectives of the EC Directives listed below and comply with harmonized European standards (EN) for programmable logic controllers published in the Gazette of the EC:

- 2006/42/EC "Machinery Directive"
- 2004/108/EC: "Electromagnetic compatibility" (EMC guideline)
- 94/9/EC "Equipment and Protective Systems Intended for Use in Potentially Explosive Atmospheres" (Explosion Protection Guideline)

The EC declarations of conformity are available to the responsible authorities at:

Siemens Aktiengesellschaft
Industry Sector
I IA AS R&D DH A
P.O. Box 1963
D-92209 Amberg, Germany

UL approval



Underwriters Laboratories Inc. to

- UL 508 (Industrial Control Equipment)
- CSA C22.2 No. 142 (Process Control Equipment)
- UL 1604 (Hazardous Location)
- CSA C22.2 No. 213 (Hazardous Location)

APPROVED for use in Class I, Division 2, Group A, B, C, D Tx; Class I, Zone 2, Group IIC Tx

Note

The rating plate of the module indicates its current approvals.

FM approval



Factory Mutual Research (FM) to

Approval Standard Class Number 3611, 3600, 3810

APPROVED for use in Class I, Division 2, Group A, B, C, D Tx; Class I, Zone 2, Group IIC Tx

 WARNING
There is a risk of personal injury or material damage.
In hazardous areas, personal injury or material damage can occur if you disconnect plug-in connections during operation.
Always shut down power to the distributed I/O before you unplug any plug-in connections in hazardous areas.



to EN 60079-15:2005 (Electrical apparatus for explosive gas atmospheres; Type of protection "n")

to EN 60079-0:2006 (Electrical apparatus for explosive gas atmospheres; general requirements)



II 3 G Ex nA II T3..T6 (except SM 326; DI 8 x NAMUR)



II 3 (2) G Ex nA [ib] IIC T4(only SM 326; DI 8 x NAMUR)

For SM 326; DI 8 x NAMUR:

94/9/EC "Equipment and protective systems for use in potentially explosive atmospheres" (Explosion Protection Directive):



II (2) G [Ex ib] IIC

This approval applies to explosive gas mixtures of Group IIC (see the *S7-300, M7-300, ET 200M Automation Systems, Principles of Intrinsically-Safe Design* manual). Safety-related limits are defined in the Certificate of Conformity (see the annex).

Note

Modules with II (2) G [Ex ib] IIC approval are considered associated equipment and must be installed outside the potentially explosive environment. Intrinsically-safe electrical equipment for Zones 1 and 2 may be connected.

Summary of UL and FM approvals

The table below provides an overview of the fail-safe signal modules, including detailed information on their approvals and fields of application.

Component	Certified to:			
	UL 508 CSA C 22.2 No. 142 UL 1604 CSA-213	FM 3611, 3600, 3810 Cl. I Div. 2 Cl. I Zone 2	ATEX 2671 X Guideline 94/9/EC	ATEX EN 60079-15
SM 326; DI 24 x DC 24V	Available	Available	No	II 3 G Ex nA II T3..T6 available
SM 326; DI 8 x NAMUR	Available	Available	II (2) G [Ex ib] IIC available	II 3 (2) G Ex nA [ib] IIC T4 available
SM 326; DO 8 x DC 24V/2A PM	Available	Available	No	Available
SM 326; DO 10 x DC 24V/2A	Available	Available	No	II 3 G Ex nA II T3..T6 available
SM 326; F-DO 10 x DC 24V/2A PP	Available	Available	No	II 3 G Ex nA II T3..T6 available
SM 336; AI 6 x 13 Bit	Available	Available	No	II 3 G Ex nA II T3..T6 available
SM 336; F-AI 6 x 0/4 ... 20 mA HART	Available	Available	No	II 3 G Ex nA II T4 available

C-Tick-Mark for Australia



The fail-safe signal modules meet requirements to AS/NZS CISPR11 (Class A).

IEC 61131

The fail-safe signal modules meet requirements and criteria to IEC 61131-2 Standard (Configurable Logic Controllers, Part 2: Equipment Requirements and Tests).

Fields of application

SIMATIC products are designed for operation in industrial environments.

Fields of application	Requirements in terms of	
	Radiated interference	Immunity to interference
Industry	EN 61000-6-4:2007	EN 61000-6-2:2005

TÜV certificate and standards

The fail-safe signal modules are certified to standards and guidelines for functional safety; for information, refer to the relevant safety certificate (TÜV certificate) report and corresponding annex. The latest TÜV documents are available in the Internet.

Requesting a TÜV certificate

You can request copies of the TÜV certificate and of the included report at the following address:

Siemens Aktiengesellschaft
 Industry Sector
 I IA AS R&D DH A
 P.O. Box 1963
 D-92209 Amberg, Germany

Type Examination Certificates and Declarations of Conformity

The type examination certificates and the declaration of conformity of the SM 326; DI 8 x NAMUR for the connection of signals in potentially explosive atmospheres (Ex area) are available in the Internet.

7.3 Electromagnetic Compatibility [ID: 431488651]

Introduction

This chapter contains information on interference immunity of the fail-safe signal modules and on RF interference suppression.

The fail-safe signal modules meet requirements of EMC legislation for the internal European market.

Definition of "EMC"

EMC expresses the ability of an electrical device to function in its electromagnetic environment in a satisfactory manner without affecting this environment.

Pulse-shaped interference

The table below shows the EMC of fail-safe modules in terms of pulse-shaped interference. The S7-300/M7-300/ET 200M system must comply with electrical installation specifications and guidelines.

Note

Not suitable for use in residential areas.

Use in residential areas is possible if suitable additional measures are taken to achieve limit class B.

Pulse-shaped interference	Test voltage	Degree of severity
Electrostatic discharge to IEC 61000-4-2 (DIN VDE 0843 Part 2)	8 kV	3 (air discharge)
	6 kV	3 (contact discharge)
Burst pulse (high-speed transient interference) to IEC 61000-4-4 (DIN VDE 0843 Part 4)	2 kV (power supply lines)	3
	2 kV (signal line)	4

Pulse-shaped interference	Test voltage	Degree of severity
Surge pulse to IEC 61000-4-5 (DIN VDE 0839 Part 10) No external protective circuit required (cf. operating instructions <i>S7-300, CPU 31xC and CPU 31x: Installation</i> , chapter "Lightning and surge voltage protection")*		2*
Asymmetrical coupling	1 kV (power supply lines) 1 kV (signal line) data line)	
Symmetrical coupling	0.5 kV (power supply lines) 0.5 kV (signal line) data line)	
*External protective circuit required for severity level 3. Test value for asymmetrical coupling = 2 kV; for symmetrical coupling = 1 kV.		

Surge protection for S7-300/ET 200M with fail-safe signal modules

If your system requires a degree of protection higher than severity level 2, it is advisable to install an external protective circuit in order to provide sufficient surge strength to an S7-300/ET 200M with fail-safe signal modules.

The precise type name is available in *S7-300 Automation System, CPU 31xC and CPU 31x: Installation*, chapter *Lightning and surge voltage protection*.

Note

Lightning protection measures always require individual assessment of the overall plant. The maximum surge protection can only be achieved if the entire building of the plant is interconnected with a surge protection system. This involves in particular structural measures in the building design phase.

In order to obtain comprehensive information about surge protection, you should consult your Siemens partner or a company specializing in lightning protection.

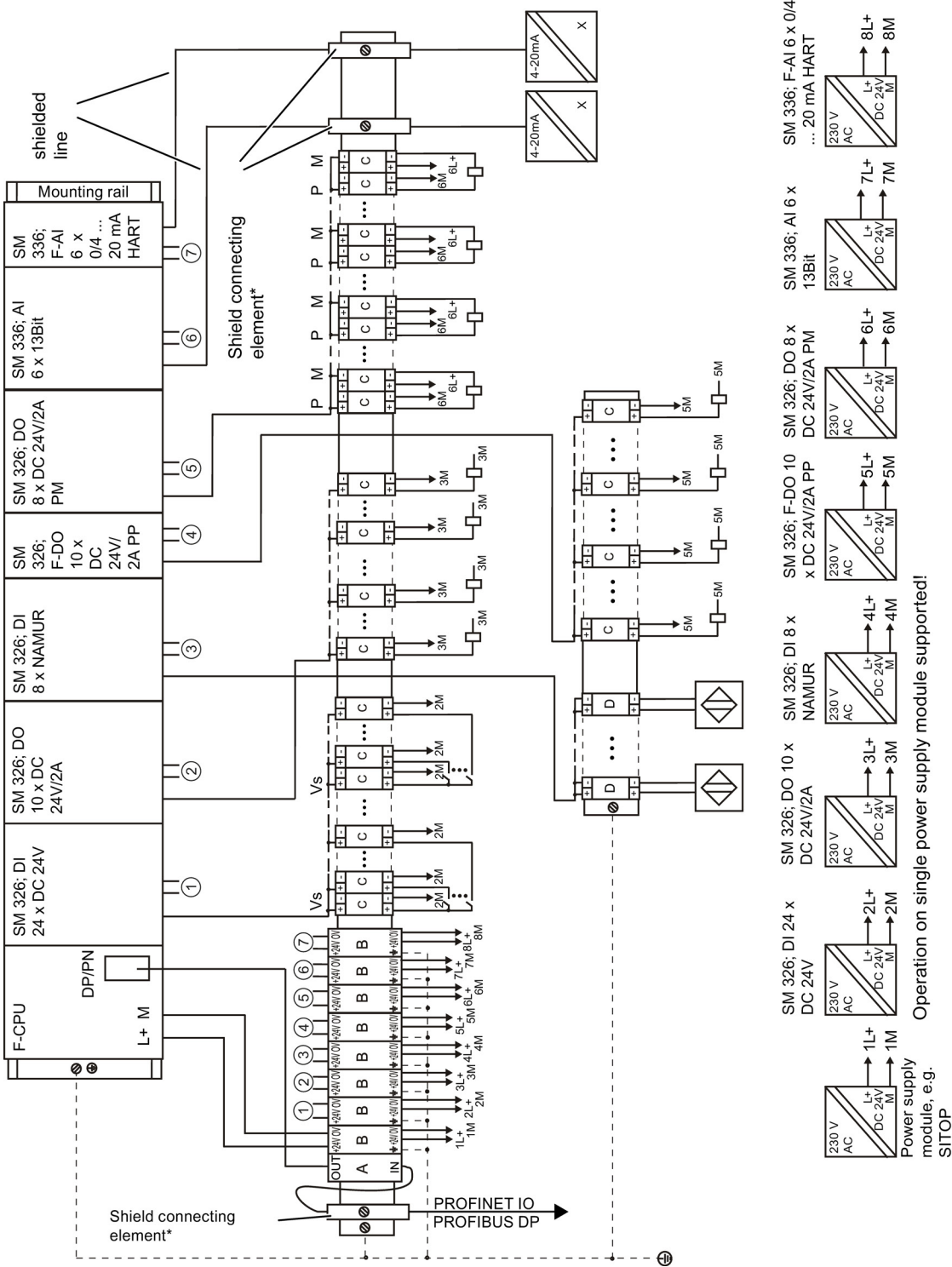

* For order numbers, refer to the ET 200S Distributed I/O System manual

- A PROFIBUS DP:
MD/HF5 + Lightning conductor CT (order numbers of Dehn company 919 571 + 919 506)
- A PROFINET IO:
Dehnpatch (order number of Dehn company 919 100)

- B Lightning conductor VT (order number of Dehn company 918 402)
- C DCO RK D 5 24 (order number of Dehn company 919 986)
- D DCO RK E 24 (order number of Dehn company 919 988)
or in case of operation in potentially explosive atmosphere:
BXT ML4 BD EX24 (order number of Dehn company 920 381)
BXT BA5 EX (order number of Dehn company 920 301)

Figure 7-1 External protective circuit (surge filter) for ET 200S with fail-safe signal modules

Note

Take the failure rate of the lightning protection elements into consideration when evaluating the safety characteristics.

Sinusoidal interference

HF radiation:

Test in accordance with IEC 61000-4-3, "Radiated Electromagnetic Field Requirements"

- Standard test:
 - 80 MHz to 1 GHz: 10 V/m, AM, 80 %, 1 kHz
 - 1,4 GHz to 2 GHz: 10 V/m, AM, 80 %, 1 kHz
 - 2,0 GHz to 2,7 GHz: 1 V/m, AM, 80 %, 1 kHz
- GSM/ISM/UMTS field interferences of different frequencies (Standard: EN 298: 2004, IEC 61326-3-1)

HF interference on signal and data lines:

Test in accordance with IEC 61000-4-6, "Testing and measurement techniques – Immunity to conducted disturbances, induced by radio-frequency fields"

- Standard test:
 - RF band, asymmetrical, amplitude modulated:
 - 0.01 MHz through 80 MHz, tested at 10 V and 20 V rms; 80% AM (1 kHz)
 - 0.15 MHz to 80 MHz, 20 V, rms; 80 % AM (1 kHz)
- ISM interferences of different frequencies (Standard: EN 298: 2004, IEC 61326-3-1)

Emission of radio interferences

Emission of electromagnetic interference to EN 55011:	
Limit class A, group 1	
from 20 MHz to 230 MHz	< 30 dB (µV/m)Q
from 230 MHz to 1000 MHz	< 37 dB (µV/m)Q
Measured at a distance of 30 m	

Interference emission at AC mains to EN 55011:	
Limit class A, group 1	
from 0.15 MHz to 0.5 MHz	< 79 dB (µV)Q, < 66 dB (µV)M
from 0.5 MHz to 5 MHz	< 73 dB (µV)Q, < 60 dB (µV)M
from 5 MHz to 30 MHz	< 73 dB (µV)Q, < 60 dB (µV)M

Redundant configuration of ET 200M

Note

If you use the ET 200M in a redundant configuration, it **must** be in a control cabinet with sufficient damping to ensure compliance with limit class A for radio interferences.

Expanding the field of application

When operating fail-safe signal modules in residential areas, you must ensure limit class B to EN 55011 in terms of RF radiation.

Measures to be taken in order achieve RF interference limit class B include:

- Installation in grounded cabinets/cubicles
- Installation of filters in the power supply lines

7.4 Shipping and storage conditions [ID: 431485963]

Conditions for fail-safe signal modules

Fail-safe signal modules exceed requirements of shipping and storage conditions to IEC 61131, Part 2. The information below applies to fail-safe signal modules which are shipped and stored in their original packaging.

Type of condition	Approved range
Free fall	≤ 1 m
Temperature	from - 40 °C to + 70°C
Air pressure	1080 hPa to 660 hPa (corresponds to an altitude from -1000 m to 3.500 m)
Relative humidity	5% to 95%, no condensation

7.5 Mechanical and Climatic Environmental Conditions [ID: 431494027]

Operating conditions

The fail-safe signal modules are designed for stationary operation in weatherproof locations. The operating conditions exceed requirements to IEC 61131-2.

The fail-safe signal modules meet conditions of application of class 3C3 according to DIN EN 60721 3-3 (locations with high traffic volume and in the immediate area of industrial plants with chemical emissions).

Restrictions

A fail-safe signal module must *not* be operated without taking additional measures

- At locations with a high level of ionizing radiation
- At locations with severe operating conditions; for example, due to
 - Formation of dust
 - Corrosive vapors or gases
- In systems that require special monitoring, such as:
 - Electrical systems in especially dangerous areas

Installation of the ET 200M/S7-300 and fail-safe signal modules in control cabinets is considered a suitable additional measure.

Mechanical environmental conditions

The mechanical environmental conditions for the operation of fail-safe signal modules are defined in the table below based on sinusoidal vibration.

Frequency range (Hz)	Continuous	Intermittent
$10 \leq f \leq 58$	Amplitude = 0.0375 mm	Amplitude = 0.075 mm
$58 \leq f \leq 150$	Constant acceleration = 0.5 g	Constant acceleration = 1 g

Reducing vibration

Suitable measures must be taken to reduce acceleration and amplitude at locations where the fail-safe signal modules are exposed to greater shock or vibration.

It is advisable to install the modules on a damping material such as rubber-to-metal vibration dampers.

Test of mechanical environmental conditions

The table defines the type and scope of testing mechanical environmental conditions.

Test of ...	Test standard	Comments
Vibration	Vibration test to IEC 68 Part 2-6 (sinusoidal)	Type of vibration: Frequency cycles at a rate of change of 1 octave/minute. 5 Hz ≤ f ≤ 9 Hz, constant Amplitude 0.075 mm 9 Hz ≤ f ≤ 150 Hz, constant Acceleration 1 g Duration of vibration: 10 frequency cycles per axis at each one of the three perpendicular axes
Shock	Shock test to IEC 68 Part 2-27	Type of shock: Half sine Severity of shock: 15 g peak value, duration 11 ms Direction of shock: Three shocks in +/- direction at each of the three perpendicular axes

Climatic environmental conditions

Climatic environmental conditions for the operation of fail-safe signal modules:

Environmental conditions	Fields of application	Comments
Temperature: Horizontal mounting position: Vertical mounting position:	from 0°C to 60°C from 0°C to 40°C	—
Relative humidity	from 5 to 95 %	No condensation; corresponds to relative humidity (RH) stress level 2 to IEC 61131-2
Air pressure	1080 hPa to 795 hPa	Corresponds to an altitude of -1000 m to 2000 m
Pollutant concentration	SO ₂ : < 0.5 ppm; Relative humidity < 60%, no dewing H ₂ S: < 0.1 ppm; Relative humidity < 60%, no dewing	Test: 10 ppm; 4 days 1 ppm; 4 days

7.6 Specifications for Nominal Line Voltages, Isolation Tests, Protection Class, and Degree of Protection [ID: 431491339]

Rated operating voltages

The fail-safe signal modules operate at a rated voltage of 24 VDC; tolerance = 20.4 VDC to 28.8 VDC.

We recommend using power supplies of the Siemens "SITOP power" series.

Test voltages

The isolation test to IEC 61131-2 and the following:

Circuits with rated voltage V_{in} to other circuits or ground	Test voltage
$0\text{ V} < V_{in} \leq 50\text{ V}$	500 VDC

Protection class

Protection class I to IEC 60536 (VDE 0106, Part 1), that is, the mounting rail must be bonded to ground!

Protection against the ingress of foreign matter and water

Degree of protection IP 20 to EN 60529, that is, protection against contact with standard test fingers

Also: Protection against the ingress of foreign particles with diameters above 12.5 mm.

No special protection against the ingress of water.

Digital modules

8.1 Introduction [ID: 431703435]

Chapter contents

Description of the four fail-safe digital modules of the S7-300 module range which are available for connecting digital sensors and/or actuators.

Information on fail-safe digital modules provided in this chapter:

- Properties
- Module view and block diagram
- Applications, including the wiring diagrams and parameter settings
- Diagnostics messages and troubleshooting routines
- Technical data

8.2 Discrepancy analysis at the fail-safe digital input modules [ID: 431706123]

Discrepancy analyses

There are two types of discrepancy analysis for fail-safe input modules:

- With 1oo2 evaluation in the digital input module
- With redundant modules

Discrepancy analysis with 1oo2 evaluation in the digital input module

The discrepancy analysis is performed in safety mode between the two input signals of the 1oo2 evaluation in the fail-safe input module.

The input signal which is returned to the F-CPU is set to "0" if the input signals do not match (due to wire break at a sensor, for example) on expiration of the assigned discrepancy time. A "discrepancy error" diagnostic message which identifies the the faulty channel is generated in the diagnostic buffer of the module.

Note

The input signals from the process are considered valid within the discrepancy time even regardless of any difference in the two readings of the redundant input signals.

Value output to the F-CPU within the internal discrepancy time of the module:

- for SM 326; DI 8 x NAMUR: the last valid value (old value) of the affected input channel
- for SM 326; DI 24 x DC 24V: the last valid value (old value) of the affected input channel or "0" value can be assigned ("discrepancy behavior" parameter)

For example, if the sensor signal is used to control a filling operation and "0 value" is output, filling will be stopped by the first of the two discrepant signals after the "0" signal is read. If the second signal does not return a "0" reading, an error is generated on expiration of the discrepancy time. Select the last valid value for this example.

"Provide last valid value"

The last value (old value) which was valid before discrepancy is detected is made available to the safety program in the fail-safe CPU as soon as a discrepancy is detected between the signals of the corresponding input channels. This value remains available until discrepancy is cleared or until the discrepancy time expires and a discrepancy error is detected. The sensor-actuator response time is extended according to this time.

That is, the discrepancy time of a high-speed two-channel sensor must be tuned to short response times.

It does not make sense to use the signals of two-channel sensors with a discrepancy time of 500 ms to initiate a time-critical shutdown. The worst-case sensor-actuator response time is extended by an amount approximately equal to the discrepancy time:

- You should for this reason integrate the sensor in the process with **minimum discrepancy**.
- Select the **shortest possible** discrepancy time in order to provide sufficient reserve against incorrect triggering of discrepancy errors.

"Provide 0 value"

The value "0" is returned to the safety program in the F-CPU as soon as discrepancy is detected between the signals of two input channels.

The sensor-actuator response time is not influenced by the discrepancy time if the "Provide 0 value" parameter is set.

Discrepancy analysis at redundant digital input modules (only in fail-safe S7 F/FH systems)

See Chapter "Configuring redundant F-I/O" in the *S7 F/FH Systems Configuring and Programming* operating instructions.

Parameter assignment

Open the object properties catalog of the fail-safe signal module in *HW Config* to assign the discrepancy time and behavior (for information on the parameters, refer to the chapters dealing with the digital input modules).

8.3 SM 326; DI 24 x DC 24V

8.3.1 Properties, Front View, Connection Diagram, and Block Diagram [ID: 431604747]

Order number

6ES7326-1BK02-0AB0

Properties

SM 326; DI 24 x DC 24V has the following properties:

- 24 inputs, electrically isolated groups of 12 inputs
- Rated input voltage 24 V DC
- Suitable for switches and 2-/3-/4-wire proximity switches (BEROs)
- Four short circuit-proof sensor supplies for each of the 6 channels, electrically isolated in groups of 2
- External sensor supply possible
- Group fault display (SF)
- Safety mode display (SAFE)
- Status display for each channel (green LED)
- Configuration in Run (CiR) supported in standard mode (non-safety mode)
- Programmable diagnostics functions
- Assignable diagnostic interrupt
- Supports operation in standard and safety mode
- SIL3/Cat.4/PLe can be achieved without safety protector
- 1oo1 and 1oo2 evaluation can be configured separately for each channel
- Simplified PROFIsafe address assignment
- I&M identification data
- can be used with PROFINET IO
- supports time stamping
- Acknowledgment possible after voltage dip

Note

The fail-safe performance characteristics in the technical data apply to a proof-test interval of 10 years and a mean time to repair of 100 hours.

Address assignment

The following figure shows the assignment of channels to addresses.

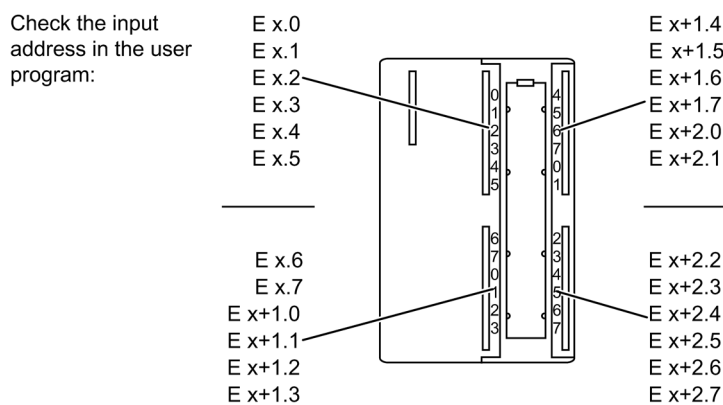

x = Module start address

Figure 8-1 Address assignment for SM 326; DI 24 x DC 24V

Configuration in RUN (CiR)

The SM 326; DI 24 x DC 24V (as of order no. 6ES7326-1BK01-0AB0) supports configuration in run (CiR) when operated in standard mode (non-safety mode).

Additional information on CiR

For additional information on CiR, refer to:

- *STEP 7* online help: "System changes in run using CiR"
- in the *Safety Engineering in SIMATIC S7* system description.

Front view

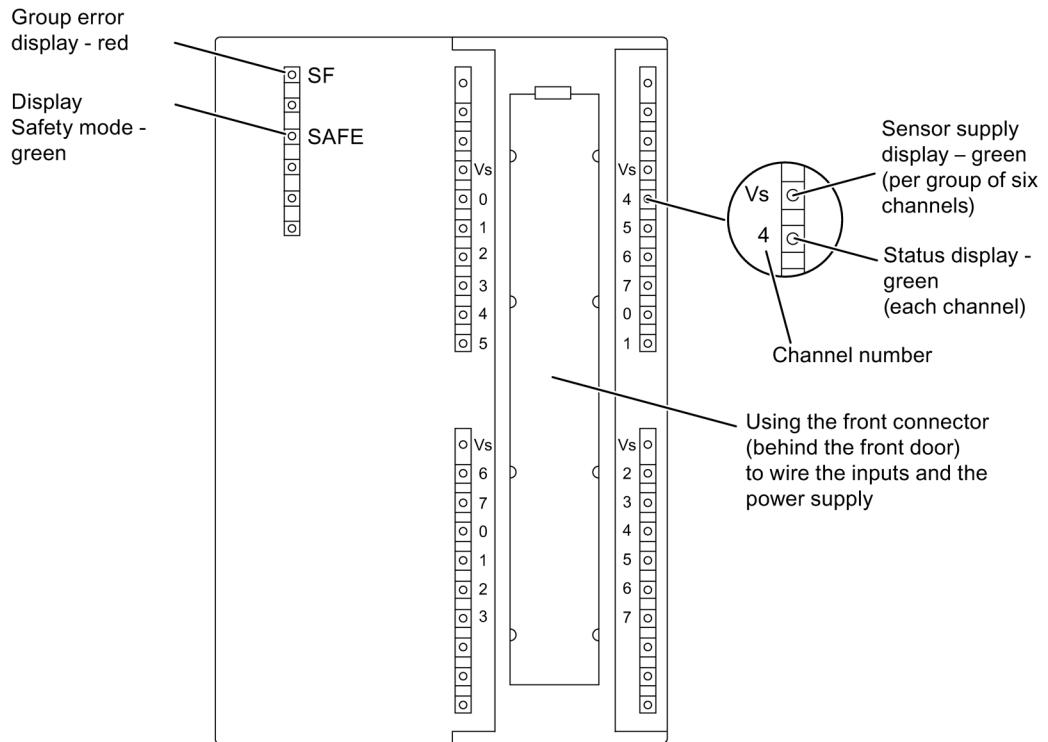

Figure 8-2 Front view of SM 326; DI 24 x DC 24V

Channel numbers

The channel numbers are used to uniquely identify the inputs and to assign channel-specific diagnostic messages. You can configure 1oo1 and 1oo2 evaluation of the sensors separately for each module channel or channel pair (see table below for example).

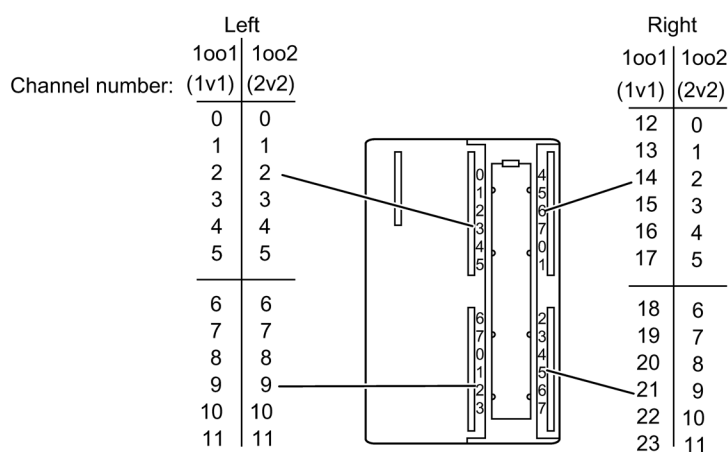
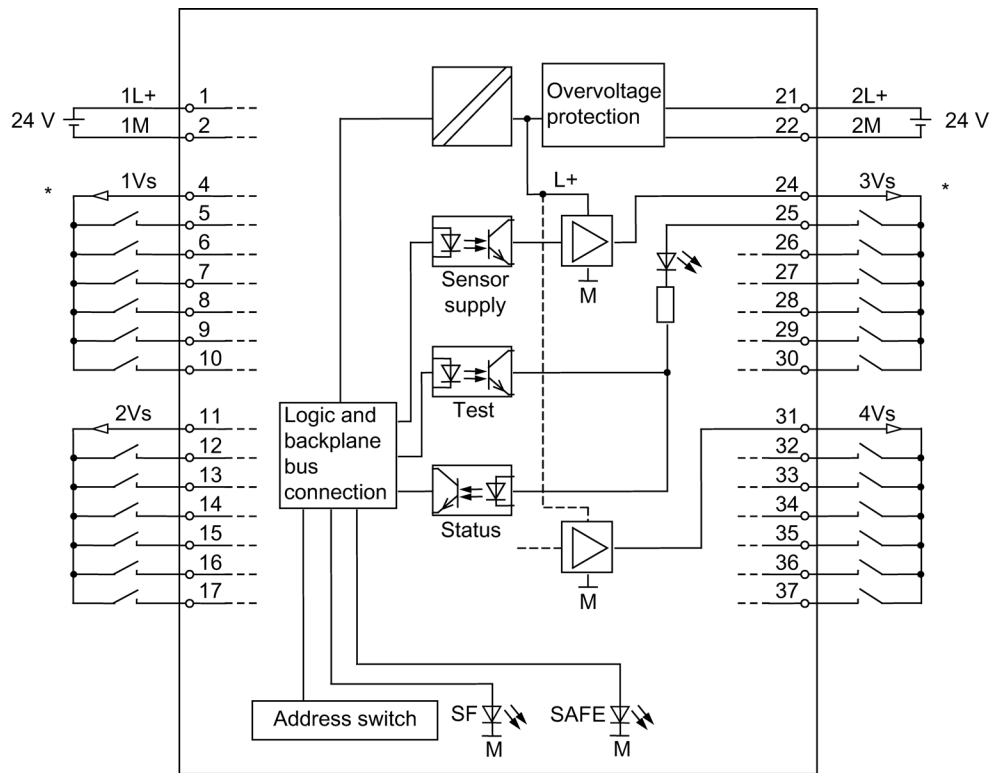

Figure 8-3 Channel numbers for SM 326; DI 24 x DC 24V

Table 8- 1 SM 326; DI 24 x DC 24V: Example of a channel configuration

Left channels	Right channels	Evaluation of the sensors	Description
0	12	1oo2	Channel pair configured for 1oo2 evaluation; channel 0 is available as I x.0 in the I/O input area in the F-CPU
1	13	1oo2	Channel pair configured for 1oo2 evaluation; channel 1 is available as I x.1 in the I/O input area in the F-CPU
2	14	1oo1	Single channels configured for 1oo1 evaluation, channels 2 and 14 are available as I x.2 and I x+1.6 in the I/O input area in the F-CPU
3	15	1oo1	Single channels configured for 1oo1 evaluation, channels 3 and 15 are available as I x.3 and I x+1.7 in the I/O input area in the F-CPU
4	16	1oo2	Channel pair configured for 1oo2 evaluation; channel 4 is available as I x.4 in the I/O input area in the F-CPU

Wiring and block diagram of SM 326; DI 24 x DC 24V and internal sensor supply



* The representation of NO contacts matches the module labeling. Usually, the sensors must be equipped with NC contacts in order to ensure the safe state of process variables.

Figure 8-4 Wiring and block diagram of SM 326; DI 24 x DC 24V and internal sensor supply

External sensor supply

The figure below shows how you can connect the sensors to an external sensor supply (for example, from another module: L+). All 6 channels of a channel group (0 to 5; 6 to 11; 12 to 17 or 18 to 23) must be connected to the same external sensor supply.

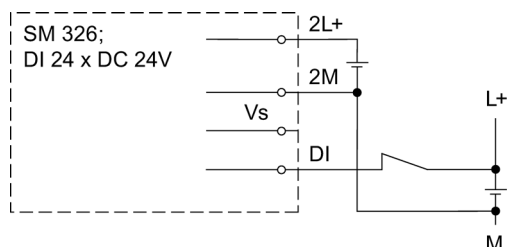

Figure 8-5 External sensor supply for SM 326; DI 24 x DC 24V

Note

Note that the errors outlined cannot be detected when operating with external sensor supply:

- Short-circuit to L+ on the unconnected sensor line (open contact)
- Short-circuit between channels of a channel group
- Short-circuit between channels of different channel groups

For electronic sensors (and therefore with external sensor supply), you can meet these three points by short-circuit proof routing of the sensor lines.

8.3.2 Use cases for the SM 326; DI 24 x 24V DC [ID: 56062220043]

Selecting the application

The figure below helps you to select an application based on availability and fail-safe operation requirements. The next pages provide information on the module wiring for specific applications, and on the parameters to set in *STEP 7* using the *S7 Distributed Safety* or *S7 F Systems* optional package.

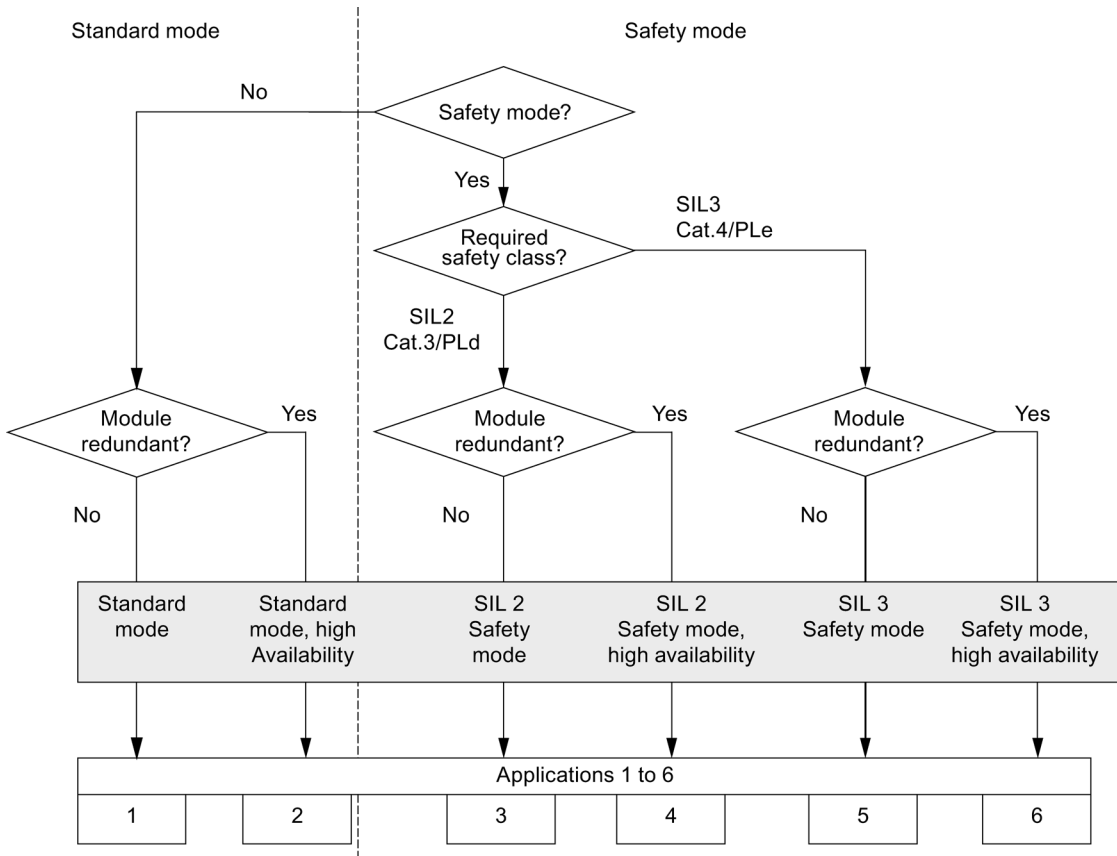

Figure 8-6 SM 326; DI 24 x DC 24V - Selecting an application

 WARNING

The maximum Safety Integrity Level is determined by the sensor quality and the length of the proof-test interval according to the IEC 61508:2000 standard. If the sensor quality does not meet Safety Integrity Level requirements, always wire redundant sensors and connect them via two channels.

Note

You can define 1oo1 and 1oo2 sensor evaluation for a module (for example, see table *SM 326; DI 24 x DC 24V: Example of channel configuration* in the section *Properties, front View, wiring diagram and block diagram*).

8.3.3 Application 1 : Standard Mode [ID: 431610123]

Introduction

Below are the wiring scheme and the parameter assignment of SM 326; DI 24 x DC 24V for application 1: Standard mode

Diagnostic messages, possible causes of the problem and their corrective measures are found in tables in the chapter "Diagnostic messages of SM 326; DI 24 x DC 24V (Page 105)".

Wiring diagram of application 1 with single-channel connection of a one sensor

A sensor is wired to a single channel for each process signal. The sensors can also be connected to an external sensor supply.

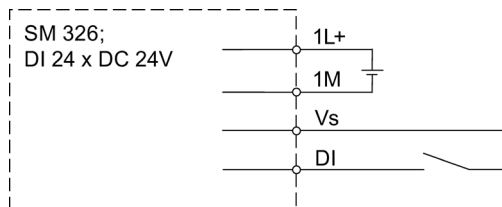

Figure 8-7 Wiring scheme of the SM 326; DI 24 x DC 24V for application 1 – one sensor single-channel connection

Assignable parameters for application 1

Table 8-2 Parameters for application 1 of SM 326; DI 24 x DC 24V

Parameters	Range of values in standard mode	Type	Effective range
"Parameters" tab			
Mode of operation	Standard mode	static	module
Module parameters:			
Diagnostic interrupt	activated/deactivated	static	module
Module parameters for a power supply group:			
Internal sensor supply of the module	activated/deactivated	static	Power supply group
Short-circuit test	activated/deactivated * (only if "Sensor Supply via Module" is activated)	static	Power supply group
For single channels or channel pairs:			
activated	activated/deactivated	static	channel
* Vs does not clock, if the short-circuit test is deactivated.			

8.3.4 Application 2 : Standard operation with high availability [ID: 431612811]

Introduction

Below are the wiring scheme and the parameter assignment of SM 326; DI 24 x DC 24V for application 2: standard mode with high availability

Diagnostic messages, possible causes of the problem and their corrective measures are found in tables in the chapter "Diagnostic messages of SM 326; DI 24 x DC 24V (Page 105)".

Wiring scheme of application 2 with single-channel connection of one sensor

One sensor is connected via one channel to two digital modules for each process signal. The sensors must be connected to an external sensor supply.

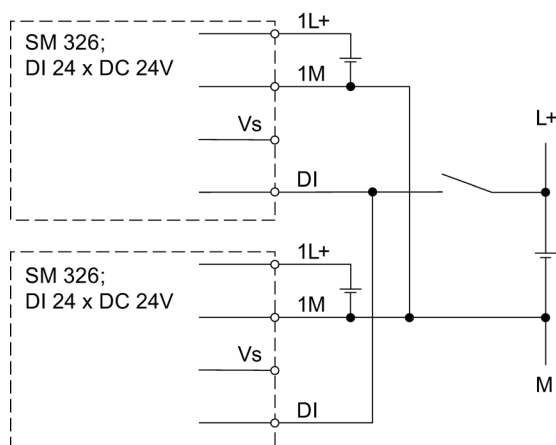

Figure 8-8 Wiring scheme of the SM 326; DI 24 x DC 24V for application 2 – one sensor single-channel connection

Wiring scheme for application 2 with single-channel connection of two redundant sensors

Two redundant sensors are wired to a single channel at the two analog modules for each process signal. The sensors can also be connected to an external sensor supply.

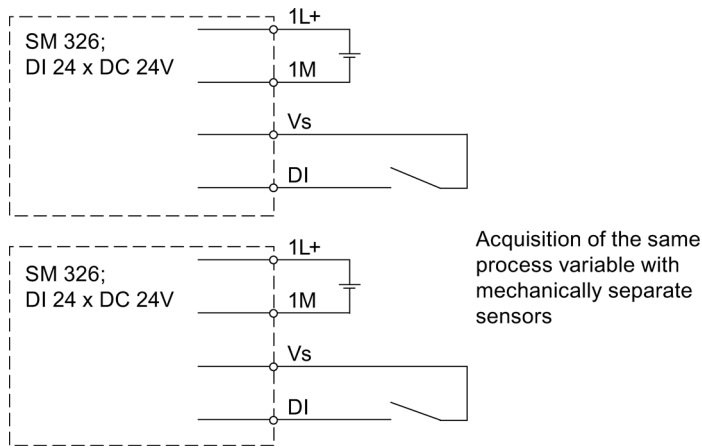

Figure 8-9 Wiring scheme of the SM 326; DI 24 x DC 24V for application 2 – two redundant sensors single-channel connection

Assignable parameters for application 2

Table 8- 3 Parameters for application 2 of SM 326; DI 24 x DC 24V

Parameters	Range of values in standard mode	Type	Effective range
"Parameters" tab			
Mode of operation	Standard mode	static	module
Module parameters:			
Diagnostic interrupt	activated/deactivated	static	module
Module parameters for a power supply group:			
Internal sensor supply of the module	<ul style="list-style-type: none"> deactivated (for single-channel connection of a sensor) activated/deactivated (for redundant sensor) 	static	Power supply group
Short-circuit test	activated/deactivated * (only if "Sensor Supply via Module" is activated)	static	Power supply group
For single channels or channel pairs:			
activated	activated/deactivated	static	channel
"Redundancy" tab **			
Redundancy	2 modules	static	module
Redundant module	(selection of an existing additional module of the same type)	static	redundant module pair
Discrepancy time	10 ms to 30000 ms	static	redundant module pair
Reaction to discrepancy error	<ul style="list-style-type: none"> Link signals by logical "AND" operation Link signals by logical "OR" operation Use last valid value 	static	redundant module pair
* Vs does not clock, if the short-circuit test is deactivated.			
** There are two digital values in the case of redundant configuration in standard mode; you must evaluate them in the standard user program.			

8.3.5 Application 3: Safety mode SIL2/Cat.3/PLd [ID: 431615499]

Introduction

Below are the wiring scheme and the parameter assignment of the SM 326; DI 24 x DC 24V digital module for application 3: Safety Mode SIL2/Cat.3/PLd.

Diagnostic messages, possible causes of the problem and their corrective measures are found in tables in the chapter "Diagnostic messages of SM 326; DI 24 x DC 24V (Page 105)".

Wiring scheme for application 3 with single-channel connection of one single-channel sensor

One sensor is connected via one channel for each process signal (1oo1 evaluation). The sensors can also be connected to an external sensor supply.

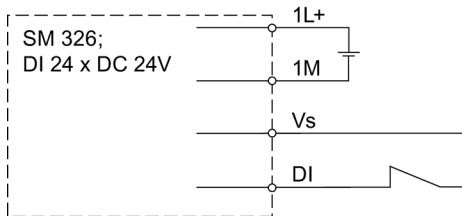



Figure 8-10 Wiring scheme of the SM 326; DI 24 x DC 24V for application 3 – one sensor single-channel connection

 WARNING
To achieve SIL2/Cat.3/PLd using this wiring, you must use a suitably qualified sensor.

Assignable parameters for application 3

Table 8- 4 Parameters for application 3 of SM 326; DI 24 x DC 24V

Parameters	Range of values in safety mode	Type	Effective range
"Parameters" tab			
Mode of operation	Safety mode	static	module
F parameter:			
F monitoring time	10 ms to 10000 ms	static	module
Module parameters:			
Diagnostic interrupt	activated/deactivated	static	module
Module parameters for a power supply group:			
Internal sensor supply of the module	activated/deactivated	static	Power supply group
Short-circuit test	activated/deactivated * (only if "Sensor Supply via Module" is activated)	static	Power supply group
For single channels or channel pairs:			
activated	activated/deactivated	static	channel
Evaluation of the sensors	1oo1 evaluation	static	Channel/channel pair
* Vs does not clock, if the short-circuit test is deactivated.			

8.3.6 Application 4: Safety mode SIL2/Cat.3/PLd with high availability (in S7 F/FH Systems only) [ID: 431618187]

Introduction

Below are the wiring scheme and the parameter assignment of the SM 326; DI 24 x DC 24V digital module for application 4: Safety Mode SIL2/Cat.3/PLd with high availability.

Diagnostic messages, possible causes of the problem and their corrective measures are found in tables in the chapter "Diagnostic messages of SM 326; DI 24 x DC 24V (Page 105)".

Wiring scheme for application 4 with single-channel connection of one sensor

One sensor is connected via one channel to the two digital modules for each process signal (1oo1 evaluation). The sensors must be connected to an external sensor supply.

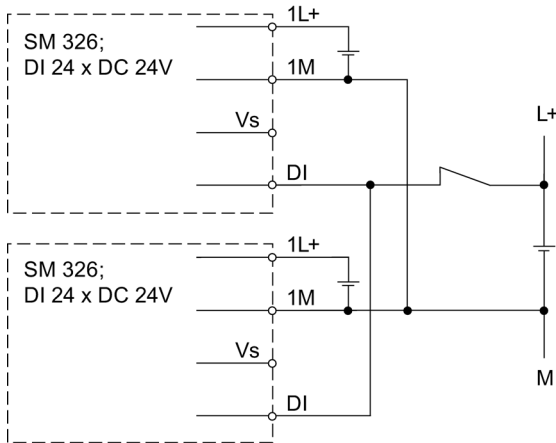



Figure 8-11 Wiring scheme of the SM 326; DI 24 x DC 24V for application 4 – one sensor single-channel connection

 WARNING
To achieve SIL2/Cat.3/PLd using this wiring, you must use a suitably qualified sensor.

Wiring scheme for application 4 with single-channel connection of two redundant sensors

Two redundant sensors are each connected via one channel to the two analog modules for each process signal (1oo1 evaluation). The sensors can also be connected to an external sensor supply.

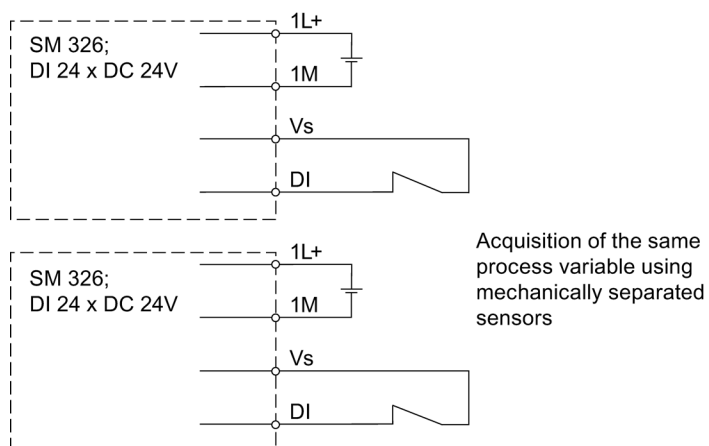

Figure 8-12 Wiring scheme of the SM 326; DI 24 x DC 24V for application 4 – two redundant sensors single-channel connection

⚠ WARNING

To achieve SIL2/Cat.3/PLd using this wiring, you must use a suitably qualified sensor.

Assignable parameters for application 4

Table 8- 5 Parameters for application 4 of SM 326; DI 24 x DC 24V

Parameters	Range of values in safety mode	Type	Effective range
"Parameters" tab			
Mode of operation	Safety mode	Static	Module
F parameter:			
F monitoring time	10 ms to 10000 ms	Static	Module
Module parameters:			
Diagnostic interrupt	activated/deactivated	Static	Module
Module parameters for a power supply group:			
Internal sensor supply of the module	Activated/deactivated	Static	Power supply group
Short-circuit test	activated/deactivated * (only if "Sensor Supply via Module" is activated)	static	Power supply group
For single channels or channel pairs:			
activated	activated/deactivated	static	channel
Evaluation of the sensors	1oo1 evaluation	static	channel
"Redundancy" tab			
Redundancy	2 modules	static	module
Redundant module	(selection of an existing additional module of the same type)	static	redundant module pair
Discrepancy time	10 ms to 30000 ms	static	redundant module pair
* Vs does not clock, if the short-circuit test is deactivated.			

8.3.7 Application 5: Safety mode SIL3/Cat.4/PLe [ID: 431620875]

Introduction

Below are the wiring scheme and the parameter assignment of the SM 326; DI 24 x DC 24V digital module for application 5: Safety mode SIL3/Cat.4/PLe.

Diagnostic messages, possible causes of the problem and their corrective measures are found in tables in the chapter "Diagnostic messages of SM 326; DI 24 x DC 24V (Page 105)".

Wiring of sensors when using the internal sensor supply of the module

Note

In general, if you connect *one* sensor to two inputs of the module and you are using the module-internal sensor supply, you must always use the sensor supply of the left half of the module 1Vs (pin 4) or 2Vs (pin 11).

Wiring scheme of application 5 with single-channel connection of one sensor

One sensor is connected via one channel to each of two *opposite inputs* of the digital module for each process signal (1oo2 evaluation). The sensors can also be connected to an external sensor supply.

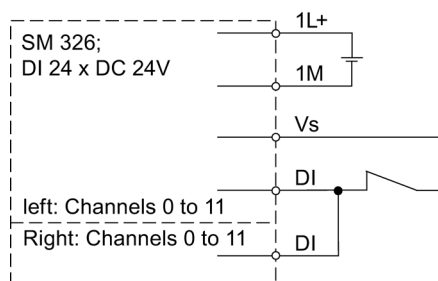

Figure 8-13 Wiring scheme of the SM 326; DI 24 x DC 24V for application 5 – one sensor single-channel connection

WARNING

To achieve SIL3/Cat.4/PLe using this wiring, you must use a suitably qualified sensor.

Wiring scheme for application 5 with two-channel nonequivalent connection of one nonequivalent sensor

One nonequivalent sensor is connected via two channels nonequivalently to each of two *opposite inputs* of the digital module for each process signal (1oo2 evaluation). The sensors can also be connected to an external sensor supply. The left channels of the module return the user signals, that is, these signals are available in the I/O area of inputs at the F-CPU if no errors are detected.

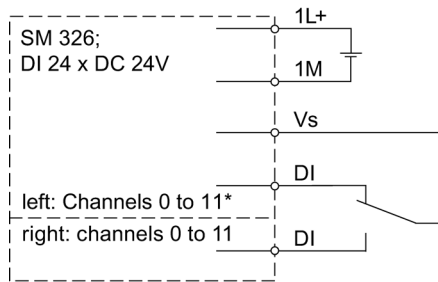

*The left channels return the user signals

Figure 8-14 Wiring scheme of the SM 326; DI 24 x DC 24V for application 5 – one nonequivalent sensor two-channel nonequivalent connection

 WARNING
To achieve SIL3/Cat.4/PLe using this wiring, you must use a suitably qualified sensor.

Wiring scheme for application 5 with nonequivalent two-channel connection of two single-channel sensors

Two single-channel sensors are connected via two channels nonequivalently to each of two *opposite inputs* of the digital module for each process signal (1oo2 evaluation structure). The sensors can also be connected to an external sensor supply. The left channels of the module return the user signals, that is, these signals are available in the I/O area of inputs at the F-CPU if no errors are detected.

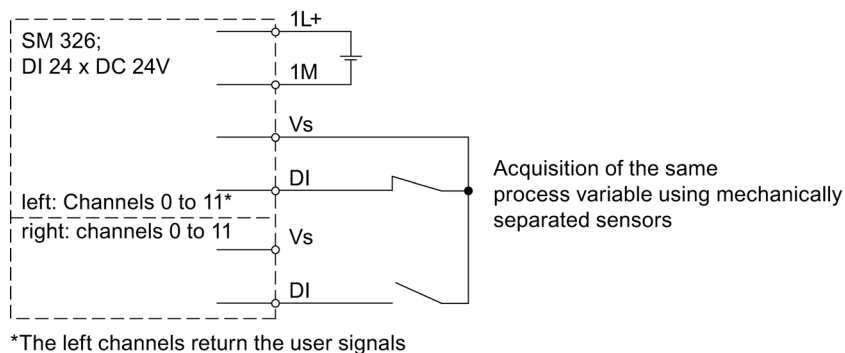

Figure 8-15 Wiring scheme of the SM 326; DI 24 x DC 24V for application 5 – two single-channel sensors two-channel nonequivalent connection

WARNING

To achieve SIL3/Cat.4/PLe using this wiring, you must use a suitably qualified sensor.

Wiring scheme for application 5 with two-channel connection of one two-channel sensor

One two-channel sensor is connected via two channels to each of two *opposite inputs* of the digital module for each process signal (1oo2 evaluation). The sensors can also be connected to an external sensor supply.

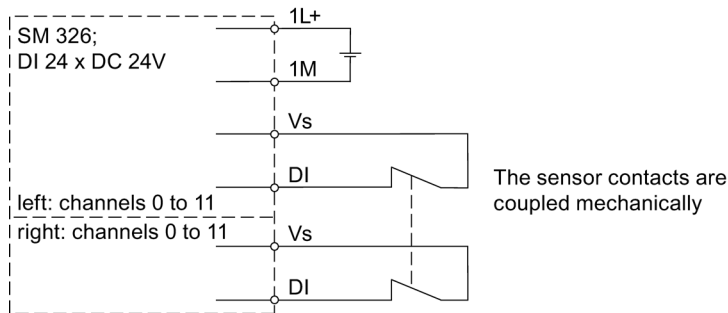



Figure 8-16 Wiring scheme of the SM 326; DI 24 x DC 24V for application 5 – one two-channel sensor two-channel connection

 WARNING
To achieve SIL3/Cat.4/PLe using this wiring, you must use a suitably qualified sensor.

Wiring scheme for application 5 with two-channel connection of two single-channel sensors

Two single-channel sensors are connected via two channels to each of two *opposite inputs* of the digital module for each process signal (1oo2 evaluation structure). The sensors can also be connected to an external sensor supply.

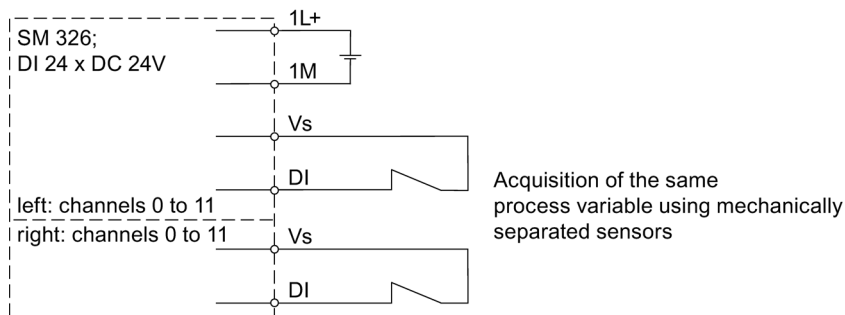



Figure 8-17 Wiring scheme of the SM 326; DI 24 x DC 24V for application 5 – two single-channel sensors two-channel connection

 WARNING
To achieve SIL3/Cat.4/PLe using this wiring, you must use a suitably qualified sensor.

Assignable parameters for application 5

Table 8- 6 Parameters for application 5 of SM 326; DI 24 x DC 24V

Parameters	Range of values in safety mode	Type	Effective range
"Parameters" tab			
Mode of operation	Safety mode	Static	Module
F parameter:			
F monitoring time	10 ms to 10000 ms	Static	Module
Module parameters:			
Diagnostic interrupt	Activated/deactivated	Static	Module
Module parameters for a power supply group:			
Internal sensor supply of the module	Activated/deactivated	Static	Power supply group
Short-circuit test	activated/deactivated * (only if "Sensor Supply via Module" is activated)	Static	Power supply group
For single channels or channel pairs:			
activated	activated/deactivated	Static	Channel pair
Evaluation of the sensors	1oo2 evaluation	Static	Channel pair
Type of sensor interconnection	<ul style="list-style-type: none"> • Two-channel, equivalent • Two-channel, nonequivalent • Single-channel 	Static	Channel pair
Discrepancy behavior	(only two-channel) <ul style="list-style-type: none"> • "Provide last valid value" • Provide 0 value 	Static	Channel pair
Discrepancy time	10 ms to 30000 ms (only for two-channel)	Static	Channel pair
* Vs does not clock, if the short-circuit test is deactivated.			

8.3.8 Application 6: Safety mode SIL3/Cat.4/PLe with high availability (in S7 F/FH Systems only) [ID: 431623563]

Introduction

Below are the wiring scheme and the parameter assignment of the SM 326; DI 24 x DC 24V digital module for application 6: Safety Mode SIL3/Cat.4/PLe with high availability.

Diagnostic messages, possible causes of the problem and their corrective measures are found in tables in the chapter "Diagnostic messages of SM 326; DI 24 x DC 24V (Page 105)".

Wiring of sensors when using the internal sensor supply of the module

Note

In general, if you connect *one* sensor to two inputs of the module and you are using the module-internal sensor supply, you must always use the sensor supply of the left half of the module 1Vs (pin 4) or 2Vs (pin 11).

Wiring scheme for application 6 with single-channel connection of two redundant single-channel sensors

Two redundant single-channel sensors are required per process signal. One sensor is connected via one channel to two *opposite inputs* of the digital module for each module (1oo2 evaluation). The sensors can also be connected to an external sensor supply.

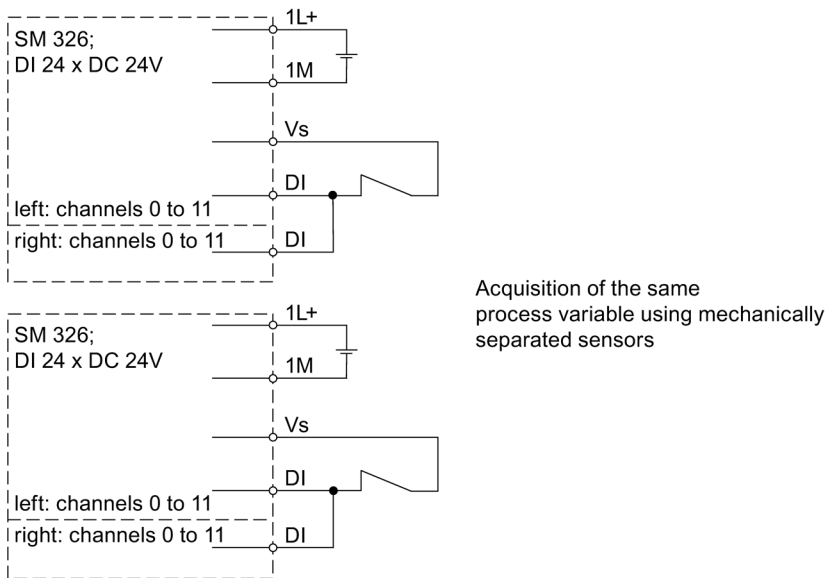

Figure 8-18 Wiring scheme of the SM 326; DI 24 x DC 24V for application 6 – two redundant, single-channel sensors single-channel connection

WARNING

To achieve SIL3/Cat.4/PLe using this wiring, you must use a suitably qualified sensor.

Wiring scheme for application 6 with nonequivalent two-channel connection of two redundant nonequivalent sensors

Two redundant nonequivalent sensors are required per process signal. One nonequivalent sensor is connected to each of two *opposite inputs* of the digital module for each module (1oo2 evaluation structure). The sensors can also be connected to an external sensor supply. The left channels of the module return the user signals, that is, these signals are available in the I/O area of inputs at the F-CPU if no errors are detected.

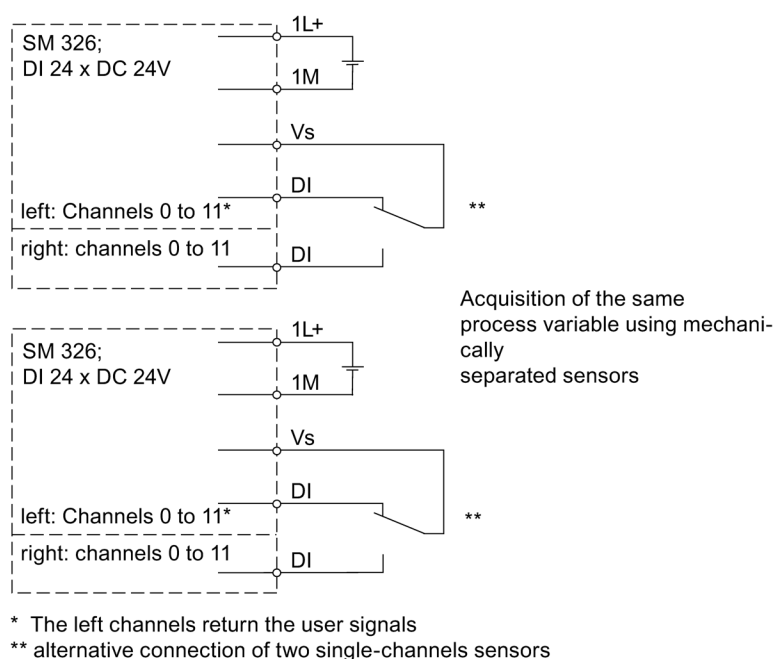

Figure 8-19 Wiring scheme of the SM 326; DI 24 x DC 24V for application 6 – two redundant, nonequivalent sensors two-channel nonequivalent connection

WARNING

To achieve SIL3/Cat.4/PLe using this wiring, you must use a suitably qualified sensor.

Wiring scheme for application 6 with two-channel connection of one two-channel sensor

One two-channel sensor is connected via two channels to the two digital modules for each process signal (1oo2 evaluation). The sensors must be connected to an external sensor supply.

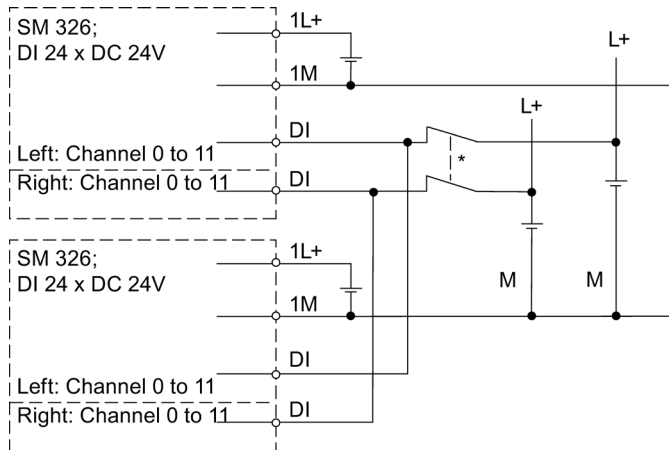

* Sensor contacts are mechanically coupled; alternatively, you can connect two single-channel sensors

Figure 8-20 Wiring scheme of the SM 326; DI 24 x DC 24V for application 6 – one two-channel sensor two-channel connection

 WARNING
To achieve SIL3/Cat.4/PLe using this wiring, you must use a suitably qualified sensor.

Wiring scheme for application 6 with two-channel connection of two redundant two-channel sensors

Two two-channel, redundant sensors are required per process signal. One sensor is connected via two channels to each of two *opposite inputs* of the digital module for each module (1oo2 evaluation). The sensors can also be connected to an external sensor supply.

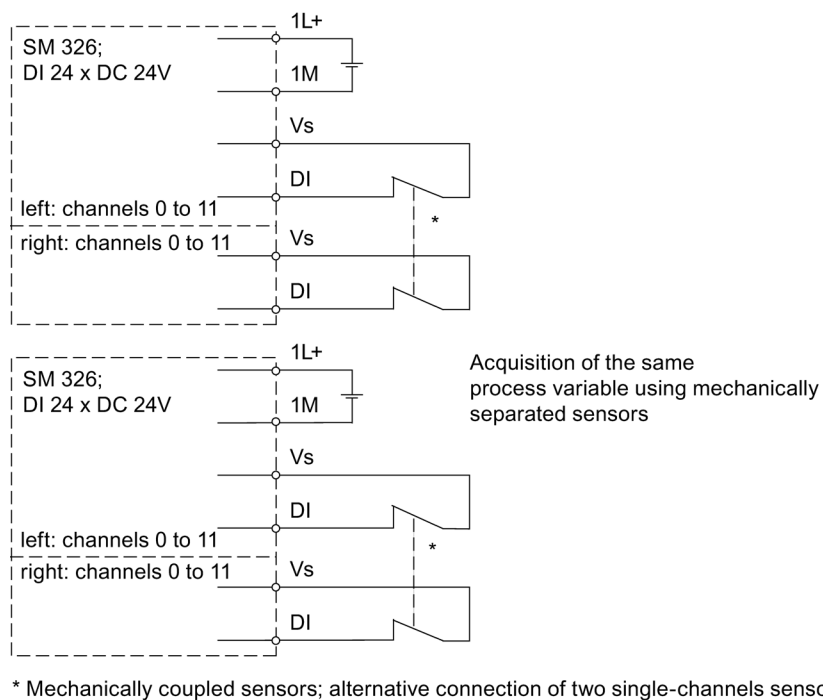

Figure 8-21 Wiring scheme of the SM 326; DI 24 x DC 24V for application 6 – two two-channel, redundant sensors two-channel connection

⚠ WARNING
 To achieve SIL3/Cat.4/PLe using this wiring, you must use a suitably qualified sensor.

Assignable parameters for application 6

Table 8- 7 Parameters for application 6 of SM 326; DI 24 x DC 24V

Parameters	Range of values in safety mode	Type	Effective range
"Parameters" tab			
Mode of operation	Safety mode	Static	Module
F parameter:			
F monitoring time	10 ms to 10000 ms	Static	Module
Module parameters:			
Diagnostic interrupt	activated/deactivated	Static	Module
Module parameters for a power supply group:			
Internal sensor supply of the module	activated/deactivated	Static	Power supply group
Short-circuit test	activated/deactivated * (only if "Sensor Supply via Module" is activated)	Static	Power supply group
For single channels or channel pairs:			
activated	activated/deactivated	Static	Channel pair
Evaluation of the sensors	1oo2 evaluation	Static	Channel pair
Type of sensor interconnection	<ul style="list-style-type: none"> • Two-channel, equivalent • Two-channel, nonequivalent • Single-channel 	Static	Channel pair
Discrepancy behavior	(only two-channel) <ul style="list-style-type: none"> • "Provide last valid value" • Provide 0 value 	Static	Channel pair
Discrepancy time	10 ms to 30000 ms (only for two-channel)	Static	Channel pair
"Redundancy" tab			
Redundancy	2 modules	Static	Module
Redundant module	(selection of an existing additional module of the same type)	Static	redundant module pair
Discrepancy time	10 ms to 30000 ms	Static	redundant module pair
* Vs does not clock, if the short-circuit test is deactivated.			

8.3.9 Diagnostic messages of SM 326; DI 24 x DC 24V [ID: 431628939]

Diagnostics using the LED display

The F-SM indicates faults by means of its SF LED (group fault LED). The SF LED is activated when the F-SM generates a diagnostic message.

The SF LED flashes as long as a cleared fault has not been acknowledged. It goes dark when all faults have been eliminated and acknowledged.

The SF LED flashes until you acknowledge passivation following a module fault.

Possible diagnostic messages

The following table provides an overview of the diagnostic messages for SM 326; DI 24 x DC 24V.

Diagnostic messages are assigned either to a channel or to the entire module. Some diagnostic messages occur only in certain applications.

Table 8- 8 Diagnostic messages of SM 326; DI 24 x DC 24V

Diagnostic message	Signaled in the application	Effective range of diagnostics	Assignable
Internal short-circuit or defective sensor supply	1, 2, 3, 4, 5, 6	Channel	Yes
Short-circuit to L+ on the unconnected sensor line (open contact)			
Ground-short circuit or defective sensor supply			
Discrepancy error (1oo2 evaluation)	5, 6		
No external auxiliary voltage	1, 2, 3, 4, 5, 6	Module	No
Module parameters not assigned			
Incorrect module parameters			
Communication error			
Internal supply voltage of the module failed			
Time monitoring activated (watchdog)			
EPROM error			
RAM error			
Processor failure			
Parameter assignment error (with specification of a consecutive number)			
Internal error in read circuit/test circuit	1, 2, 3, 4, 5, 6	Channel	
CRC signature error		Module	
Timeout of safety message frame monitoring	3, 4, 5, 6		
Message frame error	1,2	Module	

Short-circuit to M and L+

Sequence of the internal short-circuit tests:

- Short-circuit to chassis ground is always tested, independent of the configuration.
- Short-circuit to L+ is only tested if "Sensor supply via module" and "Short-circuit test" are configured in *HW Config*.

Causes of the problem and corrective measures

The table below shows possible causes of the problem and appropriate corrective measures for the individual diagnostic messages of SM 326; DI 24 x DC 24V.

Table 8-9 Diagnostic messages and associated corrective measures for SM 326; DI 24 x DC 24V

Diagnostic message	Possible causes of the problem	Corrective measures
Internal short-circuit or defective sensor supply	Internal sensor supply error	Replace the module
Short-circuit to L+ on the unconnected sensor line (open contact)	Short circuit to L+ of the unconnected sensor line (open contact)	Eliminate the short-circuit
Ground-short circuit or defective sensor supply	Short-circuit of input to M	Eliminate the short-circuit
	Internal sensor supply error	Replace the module
Short-circuit at open sense line (open contact)	Short-circuit of the unconnected sensor line to M	Eliminate the short-circuit
	Interruption of the line between the module and sensor	Restore the cable connection
Discrepancy error (1oo2 evaluation)	Process signal error Defective sensor	Check the process signal; replace the sensor
	Assigned discrepancy time too short	Check the discrepancy time parameters
No external auxiliary voltage	Module supply voltage L+ missing	Connect supply voltage L+
Module parameters not assigned	No parameters transferred to module	Assign new module parameters
Incorrect module parameters	Faulty parameters transferred to module	Assign new module parameters
Communication error	Error in communication between the CPU and the module, for example, due to defective PROFIBUS connection or electromagnetic interference in excess of limits.	Check the PROFIBUS connection Eliminate the interference
	Timeout of safety message frame monitoring	Check the monitoring time parameters
	CRC signature error, for example, due to electromagnetic interference in excess of limits.	Eliminate the interference
	CPU is in STOP	Read the diagnostics buffer
Internal supply voltage of the module failed	Internal fault at the L+ supply voltage	Replace the module

Diagnostic message	Possible causes of the problem	Corrective measures
Time monitoring activated (watchdog)	Overload due to diagnostics request (SFCs)	Reduce the number of diagnostics requests
	Electromagnetic interference has exceeded limits	Eliminate the interference
	Defective module	Replace the module
EPROM error RAM error	Electromagnetic interference has exceeded limits	Eliminate the interference and cycle the power supply OFF/ON
	Defective module	Replace the module
Processor failure	Electromagnetic interference has exceeded limits	Eliminate the interference
	Defective module	Replace the module
	Switching rate exceeded	Reduce switching rate
Internal error in read circuit/test circuit	Defective module	Replace the module
CRC signature error	CRC signature error during communication between the CPU and the module has occurred, for example, due to electromagnetic interference in excess, faults during sign-of-life monitoring error or standard program accesses F-SM.	Eliminate the interference
Timeout of safety message frame monitoring	Assigned monitoring time exceeded	Check the monitoring time parameters
	Startup of the fail-safe signal module	—
Message frame error	Sign-of-life and/or CRC signature entered in the data message frame	Check the sign-of-life and CRC signature entries in the data message frame for "0" value

8.3.10 Technical data - SM 326; DI 24 x DC 24V [ID: 8680144011]

Overview

Technical specifications		
Dimensions and weight		
Dimensions W x H x D (mm)	80 x 125 x 120	
Weight	Approx. 442 g	
Module-specific specifications		
Configuration in Run (CiR) supported	Yes (only in standard mode)	
<ul style="list-style-type: none"> Behavior of non-configured inputs during CiR 	Return the process value that was valid prior to parameter assignment	
Supports time stamping	Yes	
<ul style="list-style-type: none"> Accuracy 	20 ms to 30 ms	
Number of inputs		
<ul style="list-style-type: none"> One-channel 	24	
<ul style="list-style-type: none"> Two-channel 	12	
Assigned address area		
<ul style="list-style-type: none"> In the I/O input area 	10 bytes	
<ul style="list-style-type: none"> In the I/O output area 	4 bytes	
Cable length		
<ul style="list-style-type: none"> Unshielded 	Max. 100 m	
<ul style="list-style-type: none"> Shielded 	Max. 200 m	
Front connectors	40-pin	
Maximum achievable Safety Integrity Level in safety mode		
<ul style="list-style-type: none"> According to IEC 61508:2000 	SIL 3	
<ul style="list-style-type: none"> According to ISO 13849-1:2006 or EN ISO 13849-1:2008 	Cat. 4/PLe	
Fail-safe performance characteristics	SIL 2	SIL 3
<ul style="list-style-type: none"> low demand mode (average probability of failure on demand) 	< 1.00E-04	< 1.00E-05
<ul style="list-style-type: none"> high demand / continuous mode (probability of a dangerous failure per hour) 	< 1.00E-08	< 1.00E-09
Voltages, Currents, Potentials		
Rated supply voltage of the electronic system and sensors 1L+, 2L+	24 V DC	
<ul style="list-style-type: none"> Reverse polarity protection 	Yes	
<ul style="list-style-type: none"> Power failure ride-through (does not apply to sensor supply outputs) 	5 ms	
Number of simultaneously controllable inputs		

Technical specifications	
<ul style="list-style-type: none"> Horizontal installation Up to 40 °C Up to 60 °C 	24 24 (with 24 V) 18 (with 28.8 V)
<ul style="list-style-type: none"> Vertical installation Up to 40 °C 	24
Electrical isolation	
<ul style="list-style-type: none"> Between channels and backplane bus 	Yes
<ul style="list-style-type: none"> Between channels in groups of 	12
Maximum potential difference between different circuits	75 V DC 60 V AC
Insulation test voltage	500V DC / 350V AC for 1 min or 600V DC for 1s
Current consumption	
<ul style="list-style-type: none"> From backplane bus 	Max. 100 mA
<ul style="list-style-type: none"> From load voltage 1L+, 2L+ (no sensors) 	Max. 450 mA
Power loss of the module	10 W, typical
Status, Interrupts, Diagnostics	
Status display	Green LED per channel
Interrupts	
<ul style="list-style-type: none"> Diagnostic interrupt 	Configurable
Diagnostics functions	Configurable
<ul style="list-style-type: none"> Group fault display 	Red LED (SF)
<ul style="list-style-type: none"> Fail-safe mode display 	Green LED (SAFE)
<ul style="list-style-type: none"> Diagnostic information can be read out 	Possible
Sensor Supply Outputs	
Number of outputs	4
Electrical isolation between channels and backplane bus	Yes
<ul style="list-style-type: none"> In groups of 	2
Output voltage	
<ul style="list-style-type: none"> Loaded 	Minimum L+ (-1.5 V)
Output current	
<ul style="list-style-type: none"> Rated value 	400 mA
<ul style="list-style-type: none"> Approved range 	0 to 400 mA
Additional (redundant) infeed	Permissible
Short-circuit protection	Yes, electronic

Technical specifications	
Sensor selection data	
Input voltage	
• Rated value	24 V DC
• For "1" signal	11 to 30 V
• For "0" signal	- 30 to 5 V
Input current	
• For "1" signal	Typ. 10 mA
Input characteristic	According to IEC 61131-2 Type 1
Connection of 2-wire BERO	Supported if parameter "with short-circuit test" = "no"
Permissible quiescent current	Max. 2 mA
Time, Frequency	
Internal signal preparation time (without input delay) for	Min./max.
• Standard mode	6 ms / 22 ms
• Safety mode SIL2/Cat.3/PLd	10 ms / 23 ms
• Safety mode SIL3/Cat.4/PLe	10 ms / 22 ms
Input delay	
• For "0" after "1"	2.1 ms to 3.4 ms
• For "1" after "0"	2.1 ms to 3.4 ms
Acknowledgment time	
• In safety mode with 1oo1 evaluation of the sensors	Max. 29 ms
• In safety mode with 1oo2 evaluation of the sensors	Max. 29 ms
Minimum sensor signal duration	See table <i>Minimum duration of sensor signals for reliable detection by SM 326; DI 24 x DC 24 V</i> in section "Sensor and Actuator Requirements for F-SMs in Safety Mode (Page 50)".

Note

The maximum cable lengths currently specified in this manual ensure against functional impairment, even without more precise examination of the boundary conditions. If the boundary conditions, such as EMC, cable type, cable routing, etc. are examined more closely, longer cables can be used for all F-SMs.

8.4 SM 326; DI 8 x NAMUR

8.4.1 Properties, front view, wiring diagram and block diagram [ID: 431636747]

Order number

6ES7326-1RF00-0AB0

Properties

SM 326; DI 8 x NAMUR has the following properties:

- SIMATIC S7-Ex digital module
 - suitable for connecting signals from the Ex area
- 8 single-channel inputs or 4 two-channel inputs, electrically isolated
- Rated input voltage 24 V DC
- Suitable for the following sensors
 - In accordance with DIN 19234 and NAMUR (with diagnostic evaluation)
 - connected mechanical contacts (with diagnostic evaluation)
- 8 short-circuit-proof sensor supplies, each to one channel, electrically isolated
- Group fault display (SF)
- Safety mode display (SAFE)
- Status display for each channel (green LED)
- Programmable diagnostics functions
- Assignable diagnostic interrupt
- Supports operation in standard and safety mode

Note

The fail-safe performance characteristics in the technical data apply to a proof-test interval of 10 years and a mean time to repair of 100 hours.

Compliance with air gaps and creepage distances in the Hazardous Area

Note

For the digital input module SM 326; DI 8 x NAMUR, supply of L+ / M to maintain air gaps and creepage distances in the potentially explosive atmosphere in the Hazardous Area has to take place via the cable guide (order no. 6ES7393-4AA10-0AA0) (see chapter "Special Features when Wiring SM 326; DI 8 x NAMUR for Hazardous Areas (Page 115)").

Address assignment

The following figure shows the assignment of channels to addresses.

Check the input address in the user program:

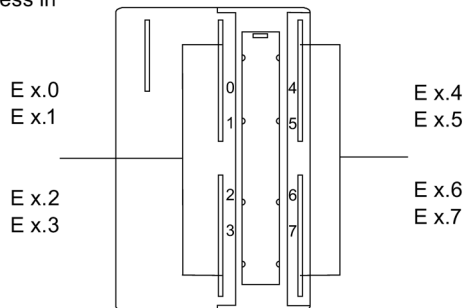

x = Module start address

Figure 8-22 Address assignment for SM 326; DI 8 x NAMUR

Front view

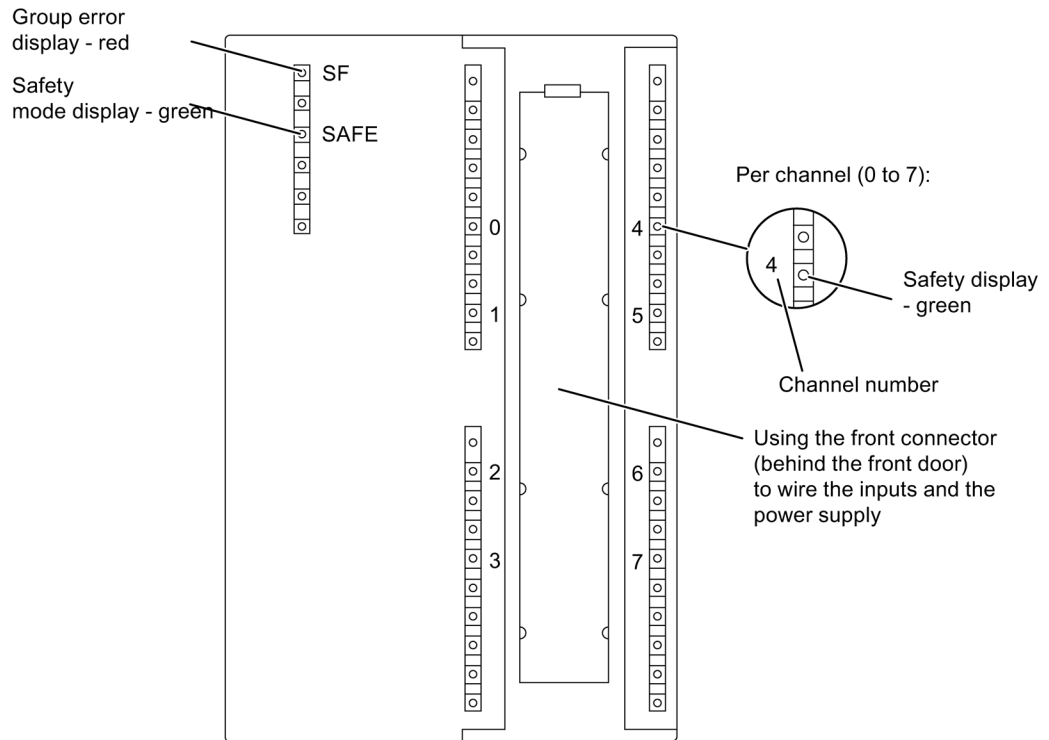
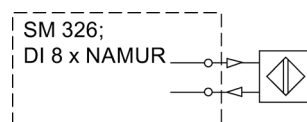

Figure 8-23 Front view of SM 326; DI 8 x NAMUR

Sensors supported

The following illustration shows the supported sensors and their connection to the SM 326; DI 8 x NAMUR.



NAMUR sensor monitoring for

- Wire break
- Short-circuit

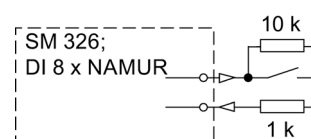

Connected contact monitored for

- Wire break
- Short-circuit

(resistors installed directly at the contact)

Wiring and block diagram

The following figure shows the the wiring and block diagram of SM 326; DI 8 x NAMUR.

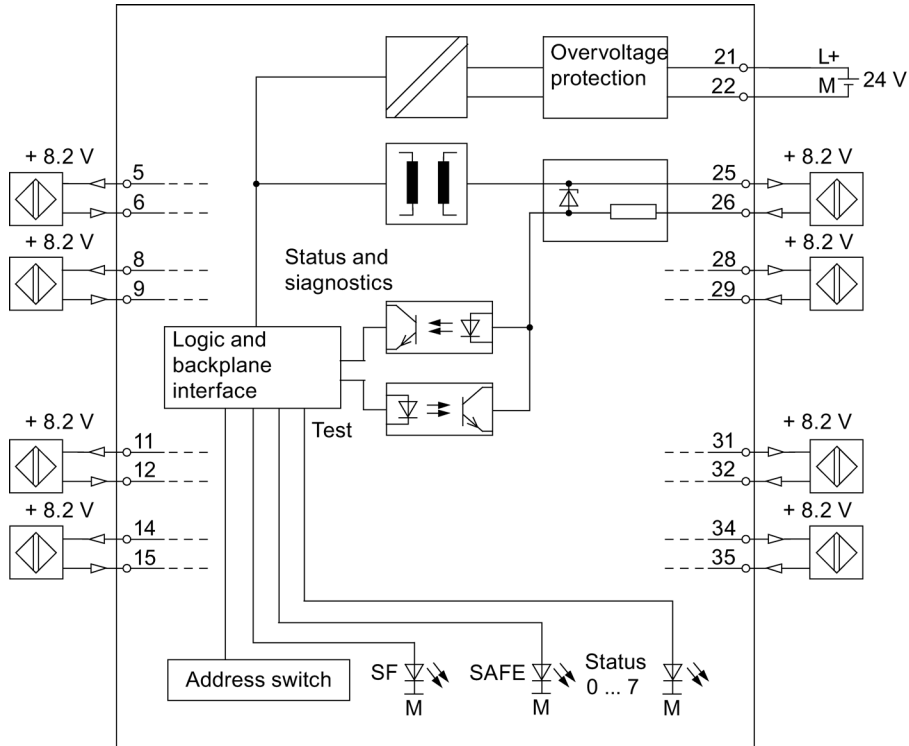

Figure 8-24 Wiring and block diagram of SM 326; DI 8 x NAMUR

Channel numbers

The channel numbers are used to uniquely identify the inputs and to assign channel-specific diagnostic messages.

1oo2 evaluation of the sensors reduces the number of channels by half.

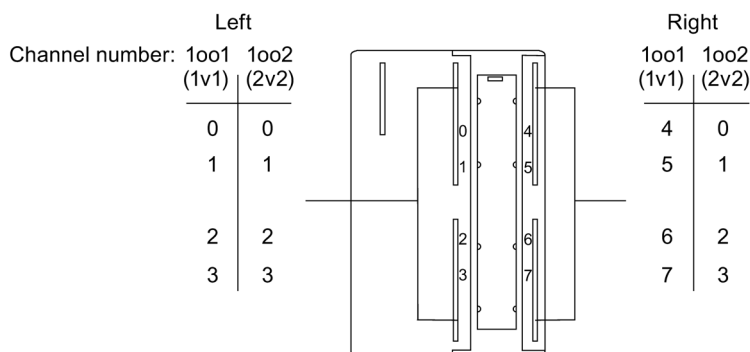

Figure 8-25 Channel numbers for SM 326; DI 8 x NAMUR

8.4.2 Special Features when Wiring SM 326; DI 8 x NAMUR for Hazardous Areas [ID: 431639435]

Cable guide for SM 326; DI 8 x NAMUR in Hazardous Area

Observe the following note when operating the SM 326; DI 8 x NAMUR in the potentially explosive area:

Note

The L+/M supply line terminals at the digital input module SM 326; DI 8 x NAMUR must be protected using a cable guide in order to conform to specified air gaps and creepage distances for operation in potentially explosive atmospheres.

Cable guide

Order number: 6ES7393-4AA10-0AA0; 5 units

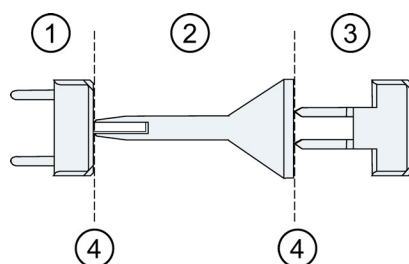

- ① Cable guide for screw-type terminals
- ② Auxiliary wedge for cage-clamp terminals
- ③ Cable guide for cage-clamp terminals
- ④ Separating lines (breaking points):
separate the three sections at these points

Figure 8-26 Cable guide for SM 326; DI 8 x NAMUR

Front connector for SM 326; DI 8 x NAMUR in Hazardous Area

To wire the 40-pin front connector:

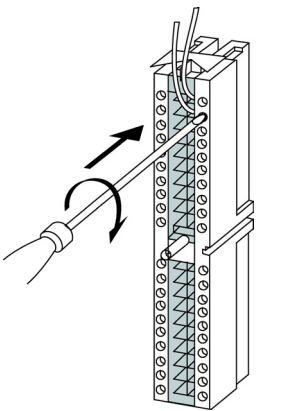
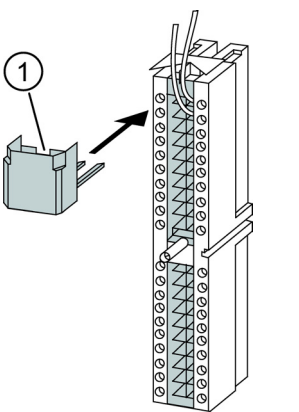
Step	Graphic	Description
1.		<p>Wire the power supply lines to terminals 21 (L+) and 22 (M) and route these to the top.</p>
2. a		<p>Insert the cable guide into terminals 3 and 23 of the front connector.</p> <p>Screw-type terminals: Tighten the screws of terminals 3 and 23.</p> <p>① Cable guide screw-type terminals</p>

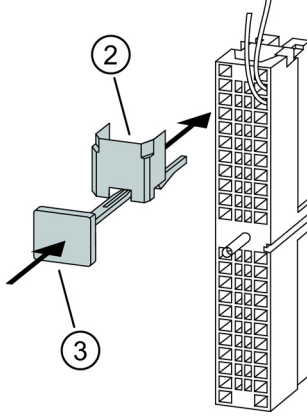
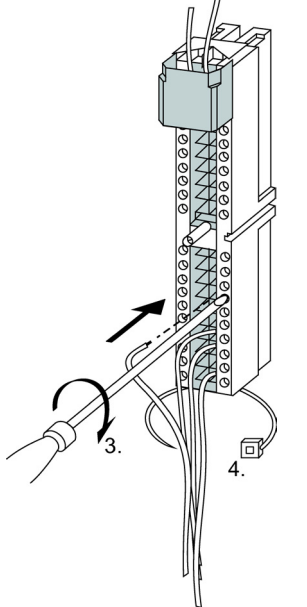
Step	Graphic	Description
2. b		<p>Cage-clamp terminals: Use the special key included instead of the screwdriver to install the cable guide.</p> <ul style="list-style-type: none"> ② Cable guide cage-clamp terminals ③ Auxiliary wedge cage-clamp terminal
3. 4.		<p>Wire the process lines and route these to the bottom.</p> <p>Do not forget to install the enclosed strain-relief for the wire harnesses.</p>

Result: The cable guide is safely installed in the front connector in compliance with safety requirements of explosion protection.

Minimum thread length with SM 326; DI 8 x NAMUR for Hazardous Area

 **WARNING**

Always maintain a minimum **thread length of 50 mm** between connections with PELV and intrinsically safe terminals of SM 326; DI 8 x NAMUR. This can be achieved by installing a cable guide in the front connector.

The minimum thread length between conductive parts may be less than 50 mm in a system which contains EX and standard modules.

To comply with thread length requirements at the modules:

- Always install the SM 326; DI 8 x NAMUR in the S7-300/ET 200M rack at the last position on the extreme right of the mounting rail; the width of SM 326; DI 8 x NAMUR automatically corrects the thread length to the next module on its left side.
- Insert the DM 370 dummy module between the relevant EX and the standard modules if this cannot be done.
- You can also install an intrinsically safe partition when using modules of the active backplane bus.

 **WARNING**

Always separate the intrinsically safe from the non-intrinsically safe wiring. Route these through separate cable ducts.

Additional information on the Hazardous Area

For further information on using the DM 370 and the Ex partition, and on separating the intrinsically safe and non-intrinsically safe wiring, refer to the *Automation Systems S7-300, M7-300, ET 200M Programmable Controllers, I/O Modules with Intrinsically-Safe Signals* Reference Manual.

8.4.3 Cases of application of SM 326; DI x 8 NAMUR [ID: 56062308491]

Selecting the application

The figure below helps you to select an application based on availability and fail-safe operation requirements. The next pages provide information on the module wiring for specific applications, and on the parameters to set in *STEP 7* using the *S7 Distributed Safety* or *S7 F Systems* optional package.

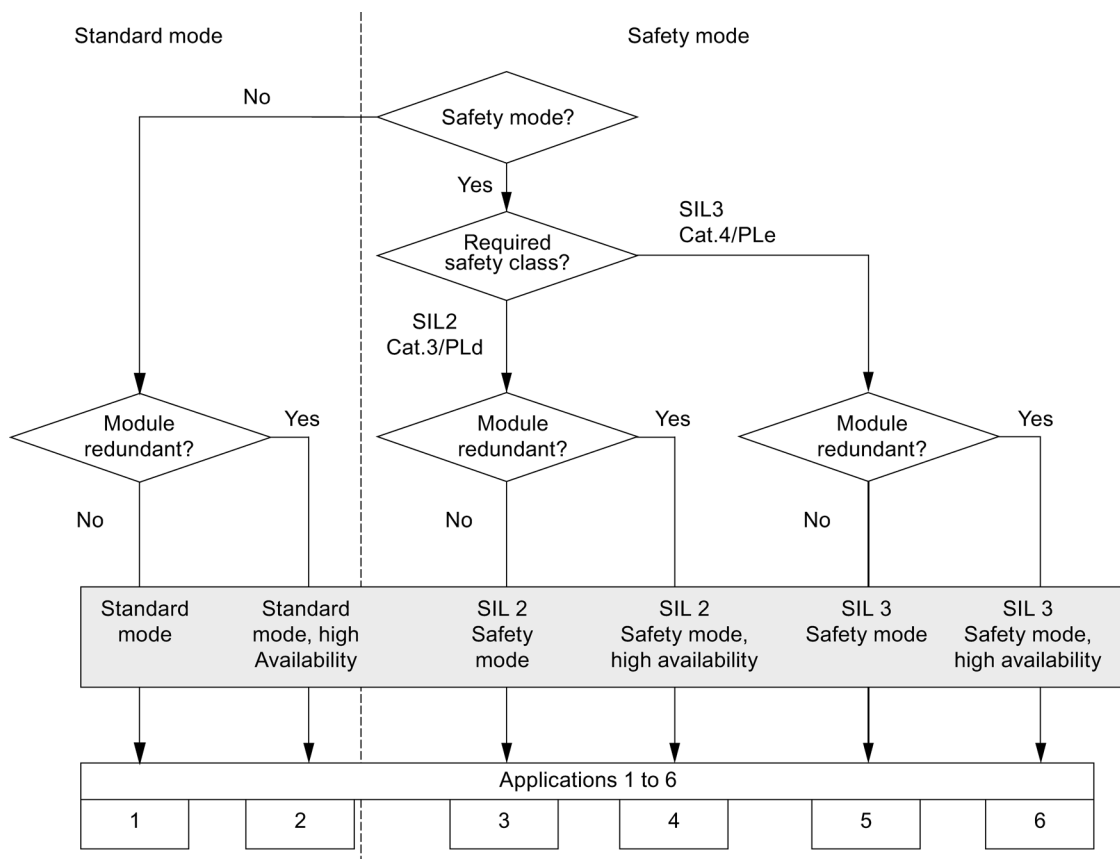



Figure 8-27 SM 326; DI x 8 NAMUR - Selecting an application

 WARNING
<p>The maximum Safety Integrity Level is determined by the sensor quality and the length of the proof-test interval according to the IEC 61508:2000 standard. If the sensor quality does not meet Safety Integrity Level requirements, always wire redundant sensors and connect them via two channels.</p>

8.4.4 Application 1: standard mode and application 3: safety mode SIL 2 (Category 3) [ID: 431644811]

Introduction

Below are the wiring scheme and the parameter assignment of SM 326; DI 8 x NAMUR for

- Application 1: standard mode and
- Application 3: Safety mode SIL2/Cat.3/PLd

Diagnostic messages, possible causes of the problem and their corrective measures are found in tables in the chapter "Diagnostic Messages for SM 326; DI 8 x NAMUR (Page 127)".

Wiring scheme of applications 1 and 3

One single-channel sensor is connected via one channel to the digital module for each process signal (1oo1 evaluation). The sensor supply Vs is made available from the digital module.

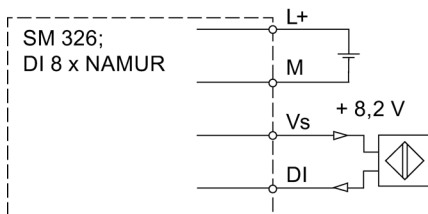

Figure 8-28 Wiring scheme of the SM 326; DI 8 x NAMUR for applications 1 and 3

	WARNING
To achieve SIL2/Cat.3/PLd using this wiring, you must use a suitably qualified sensor.	

Assignable parameters for applications 1 and 3

Table 8- 10 Parameters SM 326; DI 8 x NAMUR for applications 1 and 3

Parameters	Range of values in		Type	Effective range
	Safety mode	Standard mode		
"Inputs" tab				
Enable diagnostic interrupt	Activated/deactivated	Activated/deactivated	Static	Module
Safety mode	Activated	Deactivated	Static	Module
Monitoring time	10 ms to 10000 ms	—	Static	Module
Sensor evaluation	1oo1 evaluation	—	Static	Module
Group diagnostics	Activated/deactivated	Activated/deactivated	Static	Channel
"Redundancy" tab				
Redundancy	None	—	Static	Module

8.4.5 Application 2: standard mode with high availability and application 4: safety mode SIL 2 (Category 3) with high availability (only in S7 F/FH Systems) [ID: 431655563]

Introduction

Below are the wiring scheme and the parameter assignment of SM 326; DI 8 x NAMUR for

- Application 2: standard mode with high availability and
- Application 4: Safety Mode SIL2/Cat.3/PLd with high availability.

Diagnostic messages, possible causes of the problem and their corrective measures are found in tables in the chapter "Diagnostic Messages for SM 326; DI 8 x NAMUR (Page 127)".

Wiring scheme of applications 2 and 4

Two single-channel redundant sensors are each connected via one channel to the two digital modules for each process signal (1oo1 evaluation). The sensor supply V_s is made available from the respective digital module.

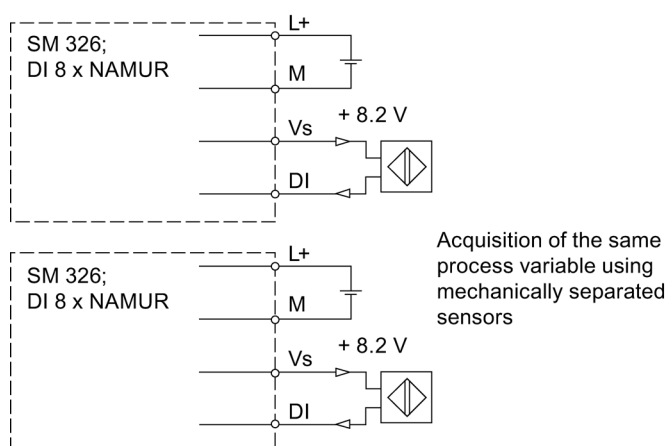



Figure 8-29 Wiring scheme of the SM 326; DI 8 x NAMUR for applications 2 and 4

 WARNING
<p>To achieve SIL2/Cat.3/PLd using this wiring, you must use a suitably qualified sensor.</p>

Assignable parameters for applications 2 and 4

Table 8- 11 Parameters SM 326; DI 8 x NAMUR for applications 2 and 4

Parameters	Range of values in		Type	Effective range
	Safety mode	Standard mode		
"Inputs" tab				
Enable diagnostic interrupt	Activated/deactivated	Activated/deactivated	Static	Module
Safety mode	Activated	Deactivated	Static	Module
Monitoring time	10 ms to 10000 ms	—	Static	Module
Sensor evaluation	1oo1 evaluation	—	Static	Module
Group diagnostics	Activated/deactivated	Activated/deactivated	Static	channel
"Redundancy" tab				
Redundancy	2 modules	— *	Static	Module
Redundant module	(selection of an existing additional module of the same type)	—	Static	redundant Module pair
Discrepancy time	10 ms to 30000 ms	—	Static	redundant Module pair
* There are two digital values in the case of redundant configuration in standard mode; you must evaluate them in the standard user program.				

8.4.6 Application 5: Safety mode SIL3/Cat.4/PLe [ID: 431647499]

Introduction

Below are the wiring scheme and the parameter assignment of SM 326; DI 8 x NAMUR for application 5: Safety mode SIL3/Cat.4/PLe.

Diagnostic messages, possible causes of the problem and their corrective measures are found in tables in the chapter "Diagnostic Messages for SM 326; DI 8 x NAMUR (Page 127)".

Wiring scheme of application 5

Two single-channel sensors are connected via two channels to each of two *opposite inputs* of the digital module for each process signal (1oo2 evaluation). The sensor supply V_s is made available from the digital module. The left channels of the module return the user signals, that is, these signals are available in the I/O area of inputs at the F-CPU if no errors are detected.

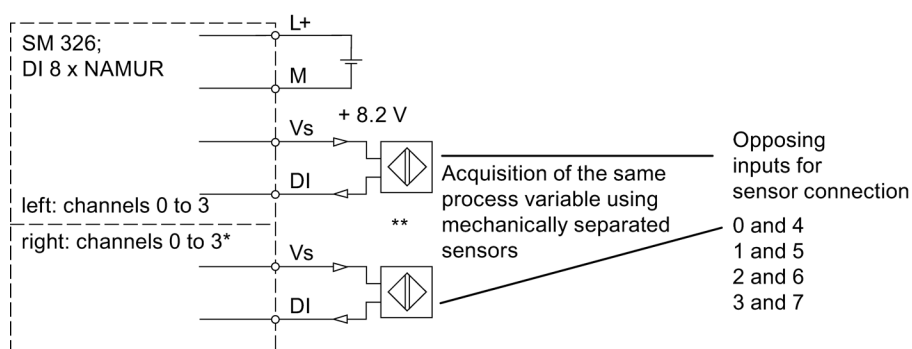

*The left channels return the user signals

** optional mechanical coupling of sensor contacts

Figure 8-30 Wiring scheme of the SM 326; DI 8 x NAMUR for application 5

WARNING

To achieve SIL3/Cat.4/PLe using this wiring, you must use a suitably qualified sensor.

Assignable parameters for application 5

Table 8- 12 Parameters for application 5 of SM 326; DI 8 x NAMUR

Parameters	Range of values in safety mode	Type	Effective range
"Inputs" tab			
Enable diagnostic interrupt	Activated/deactivated	Static	Module
Safety mode	Activated	Static	Module
Monitoring time	10 ms to 10000 ms	Static	Module
Sensor evaluation	1oo2 evaluation	Static	Module
Group diagnostics	Activated/deactivated	Static	Channel
Discrepancy time	10 ms to 30000 ms	Static	Channel
"Redundancy" tab			
Redundancy	none	Static	Module

8.4.7 Application 6: Safety mode SIL3/Cat.4/PLe with high availability (in S7 F/FH Systems only) [ID: 431650187]

Introduction

Below are the wiring scheme and the parameter assignment of SM 326; DI 8 x NAMUR for application 6: Safety Mode SIL3/Cat.4/PLe with high availability.

Diagnostic messages, possible causes of the problem and their corrective measures are found in tables in the chapter "Diagnostic Messages for SM 326; DI 8 x NAMUR (Page 127)".

Wiring scheme of application 6

Four single-channel, redundant sensors are connected via 2 channels to the two digital modules for each process signal (1oo2 evaluation). The contacts of each sensor are routed to two *opposing inputs* of the same digital module. The sensor supply V_s is made available from the respective digital module. The left channels of the module return the user signals, that is, these signals are available in the I/O area of inputs at the F-CPU if no errors are detected.

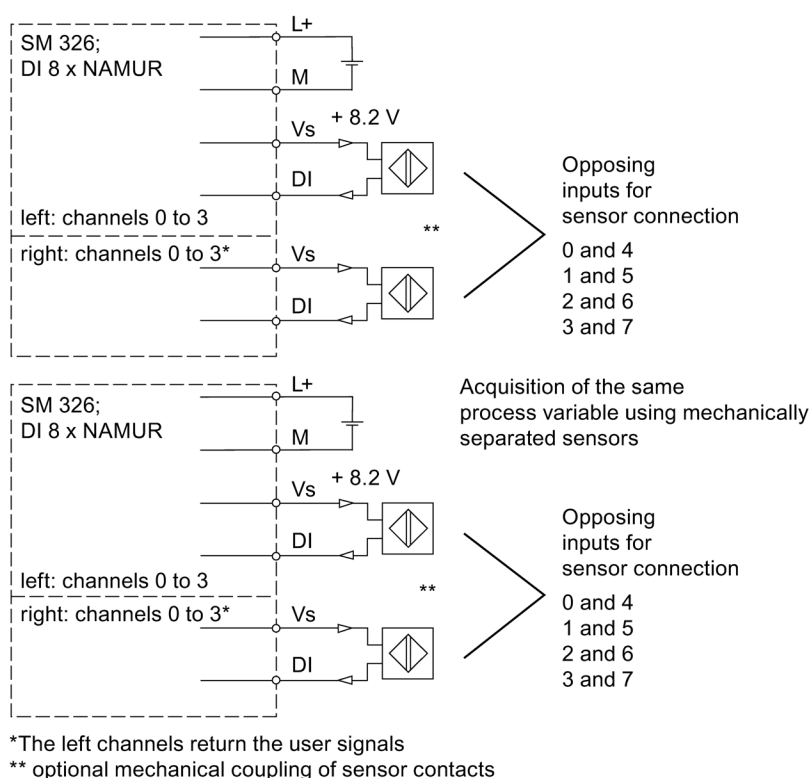



Figure 8-31 Wiring scheme of the SM 326; DI 8 x NAMUR for application 6

 WARNING
To achieve SIL3/Cat.4/PLe using this wiring, you must use a suitably qualified sensor.

Assignable parameters for application 6

Table 8- 13 Parameters for application 6 of SM 326; DI 8 x NAMUR

Parameters	Range of values in safety mode	Type	Effective range
"Inputs" tab			
Enable diagnostic interrupt	Activated/deactivated	Static	Module
Safety mode	Activated	Static	Module
Monitoring time	10 ms to 10000 ms	Static	Module
Sensor evaluation	1oo2 evaluation	Static	Module
Group diagnostics	Activated/deactivated	Static	channel
Discrepancy time	10 ms to 30000 ms	Static	channel
"Redundancy" tab			
Redundancy	2 modules	Static	Module
Redundant module	(selection of an existing additional module of the same type)	Static	redundant module pair
Discrepancy time	10 ms to 30000 ms	Static	redundant module pair

8.4.8 Diagnostic Messages for SM 326; DI 8 x NAMUR [ID: 431658251]

Possible diagnostic messages

The following table provides an overview of the diagnostic messages for SM 326; DI 8 x NAMUR.

Diagnostic messages are assigned either to a channel or to the entire module. Some diagnostic messages occur only in certain applications.

Table 8- 14 Diagnostic messages of SM 326; DI 8 x NAMUR

Diagnostic message	Signaled in the application	Effective range of diagnostics	Assignable
Wire break or internal fault at the sensor supply	1, 2, 3, 4, 5, 6	channel	yes
Short-circuit between sensor signal and supply lines			
Internal error in read circuit/test circuit or defective sensor supply			No
Discrepancy error (1oo2 evaluation)	5, 6	channel	Yes
No external auxiliary voltage	1, 2, 3, 4, 5, 6	Module	No
Module parameters not assigned			
Incorrect module parameters			
Communication error			
Internal supply voltage of the module failed			
Time monitoring activated (watchdog)			
EPROM error			
RAM error			
Processor failure			
Parameter assignment error (with specification of a consecutive number)			
CRC signature error	3, 4, 5, 6	Module	
Timeout of safety message frame monitoring			
Message frame error			

Causes of the problem and corrective measures

The table below shows possible causes of the problem and appropriate corrective measures for the individual diagnostic messages of SM 326, DI 8 x NAMUR.

Table 8- 15 Diagnostic messages and associated corrective measures for SM 326; DI 8 x NAMUR

Diagnostic message	Possible causes of the problem	Corrective measures
Wire break or internal fault at the sensor supply	Interruption of the cable connection between the module and NAMUR sensor	Restore the cable connection
	Contacts as sensors: 10 kΩ series resistance directly via contact is missing or interrupted	Add 10 kΩ series resistance directly via contact
	Channel not connected (open)	Disable the "Group Diagnostics" for the channel in the parameter settings.
	Internal sensor supply error	Replace the module
Short-circuit between sensor signal and supply lines	Short-circuit between the two sensor signal lines	Eliminate the short-circuit
Discrepancy error (1002 evaluation)	Process signal error Defective NAMUR sensor	Check the process signal; replace the NAMUR sensor
	Short-circuit between the supply line and the open signal line (open contact) of the sensor	Eliminate the short-circuit
	Wire break in connected sensor line (contact closed) or the sensor supply line	Eliminate the wire break
	Assigned discrepancy time too short	Check the discrepancy time parameters
No external auxiliary voltage	Module supply voltage L+ missing	Connect supply voltage L+
Module parameters not assigned	No parameters transferred to module	Assign new module parameters
Incorrect module parameters	Faulty parameters transferred to module	Assign new module parameters
	Mismatch between the logical module address set in <i>STEP 7</i> and the address switch setting on the module.	Adjust the address settings and assign new parameters to the module
Communication error	Error in communication between the CPU and the module, for example, due to defective PROFIBUS connection or electromagnetic interference in excess of limits.	Check the PROFIBUS connection Eliminate the interference
	Timeout of data frame monitoring	Check the monitoring time parameters
	CRC signature error, for example, due to electromagnetic interference in excess of limits.	Eliminate the interference

Diagnostic message	Possible causes of the problem	Corrective measures
	CPU is in STOP	Read the diagnostics buffer
Internal supply voltage of the module failed	Internal fault at the L+ supply voltage	Replace the module
Time monitoring activated (watchdog)	Overload due to diagnostics request (SFCs)	Reduce the number of diagnostics requests
	Electromagnetic interference has exceeded limits	Eliminate the interference
	Defective module	Replace the module
EPROM error RAM error	Electromagnetic interference has exceeded limits	Eliminate the interference and cycle the power supply OFF/ON
	Defective module	Replace the module
Internal error in read circuit/test circuit or defective sensor supply	Defective module	Replace the module
Processor failure	Electromagnetic interference has exceeded limits	Eliminate the interference
	Defective module	Replace the module
	Switching rate exceeded	Reduce switching rate
Parameter assignment error (with specification of a consecutive number)	Error in dynamic parameter reassignment	Check the parameter assignment in the user program Contact SIMATIC Customer Support if necessary
CRC signature error	CRC signature error during communication between the CPU and the module has occurred, for example, due to electromagnetic interference in excess, faults during sign-of-life monitoring error or standard program accesses F-SM.	Eliminate the interference
Timeout of safety message frame monitoring	Assigned monitoring time exceeded	Check the monitoring time parameters
	Startup of the fail-safe signal module	—
Message frame error	Sign-of-life and/or CRC signature entered in the data message frame	Check the sign-of-life and CRC signature entries in the data message frame for "0" value

8.4.9 Technical data - SM 326; DI 8 x NAMUR [ID: 8680510987]

Overview

Technical specifications		
Dimensions and weight		
Dimensions W x H x D (mm)	80 x 125 x 120	
Weight	Approx. 482 g	
Module-specific specifications		
Number of inputs		
• One-channel	8	
• Two-channel	4	
Assigned address area		
• In the I/O input area	6 bytes	
• In the I/O output area	4 bytes	
Cable length		
• Shielded	Max. 200 m	
• Unshielded	Max. 100 m	
Front connectors	40-pin	
Ignition protection type	II 3 (2) G Ex nA [ib] IIC T4 to EN 60079-11, EN 60079-0, EN 60079-15	
Test number KEMA	99 ATEX 2671 X	
Maximum achievable Safety Integrity Level in safety mode	One-channel	Two-channel
• According to IEC 61508:2000	SIL 2	SIL 3
• According to ISO 13849-1:2006 or EN ISO 13849-1:2008	Cat. 3/PLd	Cat. 4/PLe
Fail-safe performance characteristics	SIL 2	SIL 3
• low demand mode (average probability of failure on demand)	< 1.00E-04	< 1.00E-05
• high demand / continuous mode (probability of a dangerous failure per hour)	< 1.00E-08	< 1.00E-09
Voltages, Currents, Potentials		
Rated supply voltage of the electronic system and sensors L +	24 V DC	
• Reverse polarity protection	Yes	
• Power failure ride-through	5 ms	
Number of simultaneously controllable inputs		
• Horizontal installation up to 60 °C	8	
• Vertical installation up to 40 °C	8	

Technical specifications		
Electrical isolation		
• Between channels and backplane bus		Yes
• Between channels and the power supply of the electronics		Yes
• Between channels		Yes
Permitted potential difference		
• Between different circuits [Ex]		60 V DC 30 V AC
• Between different circuits [non Ex]		75 V DC 60 V AC
Insulation test voltage		
• Channels to backplane bus and load voltage L+		1500 V AC
• Load voltage L+ to backplane bus		500 V DC or 350 V AC
• Between channels		1500 V AC
Current consumption		
• From backplane bus		Max. 90 mA
• From load voltage L+ (without sensor)		Max. 160 mA
Power loss of the module		4.5 W, typical
Status, Interrupts, Diagnostics		
Status display		Green LED per channel
Interrupts		
• Diagnostic interrupt		Configurable
Diagnostics functions		Configurable
• Group fault display		Red LED (group error)
• Fail-safe mode display		green LED (SAFE)
• Diagnostic information can be read out		supported
Sensor Supply Outputs		
Number of outputs		8
Output voltage		8.2 V DC
Short-circuit protection		Yes, electronic
Safety notice (see the certificate of conformity in the annex)		
Maximum values of input circuits (per channel)		
• U_0	(No-load output voltage)	Max. 10 V
• I_0	(Short-circuit current)	Max. 13.9 mA
• P_0	(Load power)	Max. 33.1 mW
• L_0	(Permissible external inductance)	Max. 80 mH
• C_0	(Permissible external capacitance)	Max. 3 μ F

Technical specifications		
• U _m	(Fault voltage)	Max. 60 V DC Max. 30 V AC
• T _a	(Permissible ambient temperature)	Max. 60 °C
Sensor selection data		
Sensor		In accordance with DIN 19234 or NAMUR
Input current		
• For "0" signal		0.35 to 1.2 mA
• For "1" signal		2.1 to 7 mA
Time, Frequency		
Internal signal preparation time (without input delay) for		Typ. Max.
• Standard mode		55 ms 60 ms
• Safety mode		55 ms 60 ms
Input delay		
For "0" after "1"		1.2 ms to 3 ms
For "1" after "0"		1.2 ms to 3 ms
Acknowledgment time		
• In safety mode		Max. 68 ms
Minimum sensor signal duration		Min. 38 ms

Note

The maximum cable lengths currently specified in this manual ensure against functional impairment, even without more precise examination of the boundary conditions. If the boundary conditions, such as EMC, cable type, cable routing, etc. are examined more closely, longer cables can be used for all F-SMs.

8.5 SM 326; DO 8 x DC 24V/2A PM

8.5.1 Properties, front view, wiring diagram and block diagram [ID: 431666059]

Order number

6ES7326-2BF41-0AB0

Properties

SM 326; DO 8 x DC 24V/2A PM has the following properties:

- 8 outputs, two electrically isolated groups of 4
- P/M switching (current source/sink)
- Output current 2 A
- Rated load voltage 24 V DC
- Suitable for solenoid valves, DC relay contactors, and signal lamps
- Group fault display (SF)
- Safety mode display (SAFE)
- Status display for each channel (green LED)
- Programmable diagnostics functions
- Programmable diagnostic interrupt
- Supports operation in safety mode
- SIL3/Cat.4/PLe can be achieved without safety protector
- Simplified PROFIsafe address assignment
- I&M identification data
- can be used with PROFINET IO
- Acknowledgment possible after voltage dip
- greater cable lengths are possible

Note

The fail-safe performance characteristics in the technical data apply to a proof-test interval of 10 years and a mean time to repair of 100 hours.

Note

You can install the SM 326; DO 8 x DC 24V/2A PM centrally with all F-CPU's of the S7-300 spectrum but

- CPU 315F-2 DP as of order number 6ES7315-6FF01-0AB0only , firmware version V2.0.9 and
- CPU 317F-2 DP as of order number 6ES7317-6FF00-0AB0only , firmware version V2.1.4

Address assignment

The following figure shows the assignment of channels to addresses.

Check the output address in the user program:

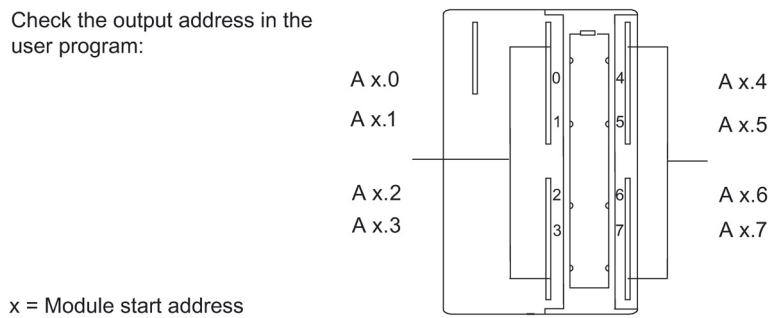

Figure 8-32 Address assignment for SM 326; DO 8 x DC 24V/2A PM

Front view

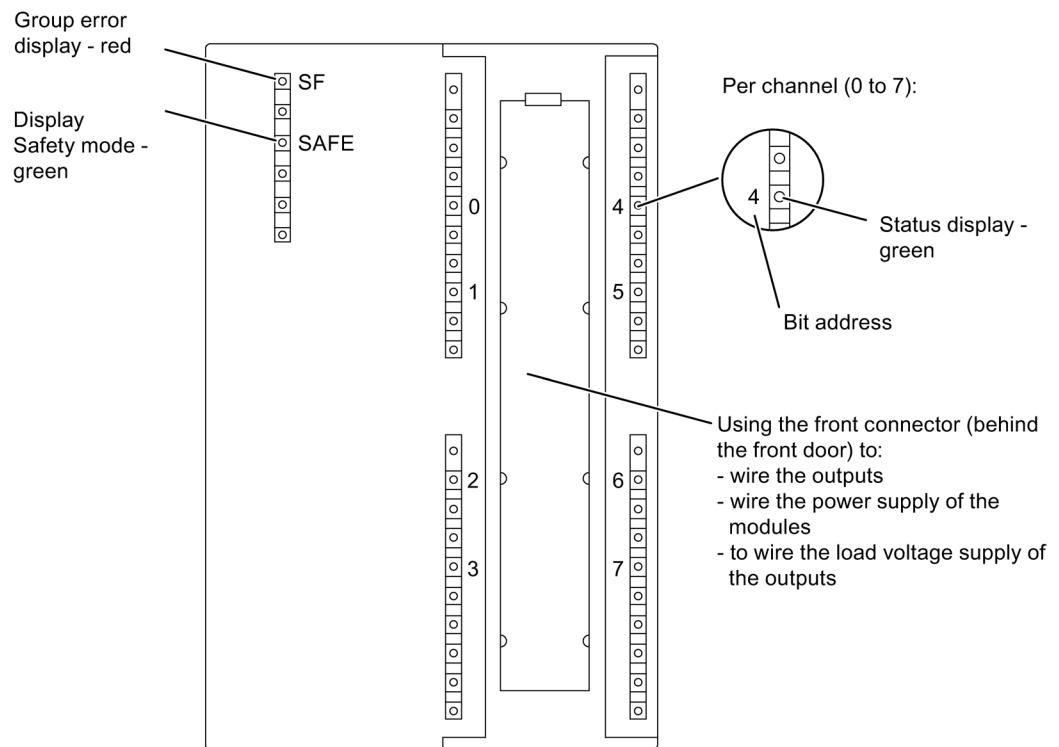

Figure 8-33 Front view of the SM 326; DO 8 x DC 24V /2A PM with diagnostic interrupt

Wiring and block diagram

The following figure shows the wiring and block diagram of SM 326; DO 8 x DC 24V/2A PM.

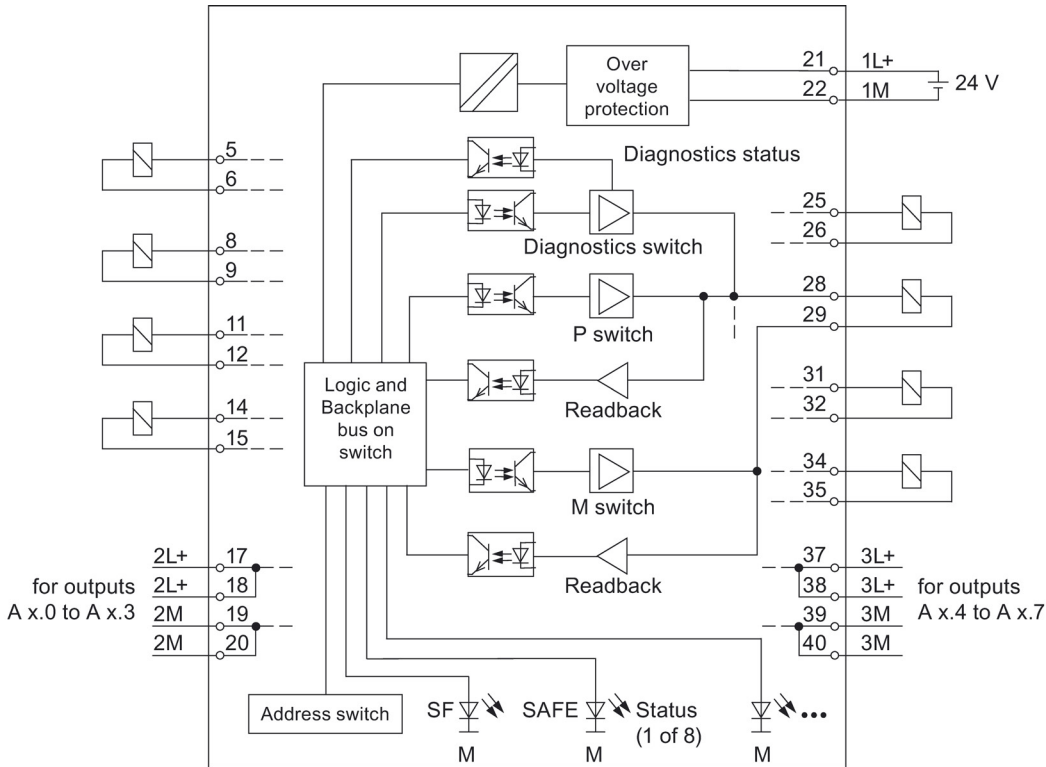

Figure 8-34 Wiring and block diagram of SM 326; DO 8 x DC 24V/2A PM

Channel numbers

The channel numbers are used to identify the outputs and to assign channel-specific diagnostic messages.

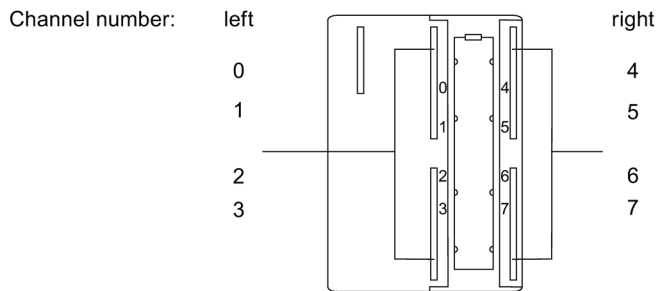

Figure 8-35 Channel numbers for SM 326; DO 8 x DC 24V/2A PM

8.5.2 SM 326; DO 8 x DC 24V/2A PM applications [ID: 431668747]

Selecting the application

The figure below helps you to select an application based on availability and fail-safe operation requirements. The next pages provide information on the module wiring for a specific application, and on the parameters to set in *STEP 7* using the *S7 Distributed Safety* or *S7 F Systems* optional package.

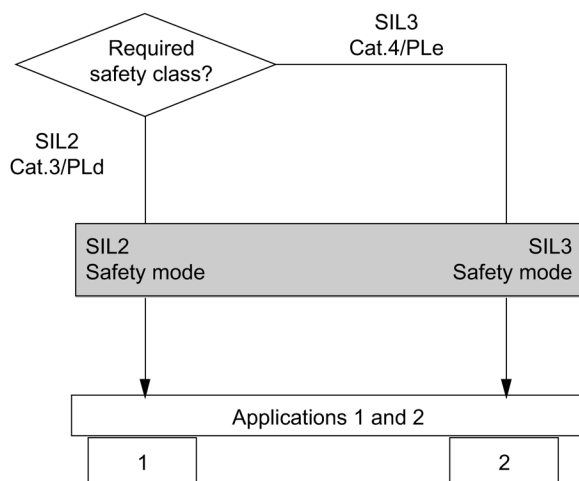

Figure 8-36 SM 326; DO 8 x DC 24V/2A PM - Selecting an application

8.5.3 Application 1: Safety Mode SIL2/Cat.3/PLd and application 2: Safety mode SIL3/Cat.4/PLe [ID: 431671435]

Introduction

Below are the wiring scheme and the parameter assignment of SM 326; DO 8 x DC 24V/2A PM for

- application 1: Safety mode SIL2/Cat.3/PLd
- Application 2: Safety mode SIL3/Cat.4/PLe

Diagnostic messages, possible causes of the problem and their corrective measures are found in tables in the chapter "Diagnostic messages of SM 326; DO 8 x DC 24V/2A PM (Page 140)".

Wiring scheme of applications 1 and 2

Each one of the 8 fail-safe digital outputs consists of one DOx P-switch (current source) and one DOx M-switch (current consumer); connect the load between the P and M switches.

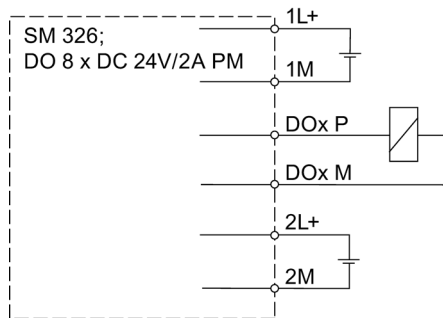

Figure 8-37 Wiring scheme of the SM 326; DO 8 x DC 24V/2A PM for applications 1 and 2

Wiring two relays to one digital output

The fail-safe digital output is capable of controlling two relays. Note the following conditions:

- Wire L+ and M of the relays to L+ and M of the module (same reference potential required).
- Wire the NO contacts of the two relays in series.

The relays can be wired to any one of the 8 digital outputs. The figure below shows an example of an output wiring. This circuit is compliant with SIL 3/Cat. 4/PLe.

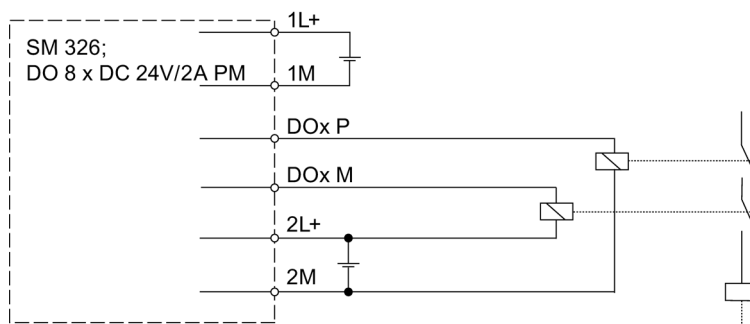

Figure 8-38 Wiring scheme 2 relays at digital output of SM 326; DO 8 x DC 24V/2A PM

⚠ WARNING

To prevent short circuits between the P and M switches of a fail-safe digital output, you must route the cables used to connect the relays on the P and M switches in a cross-circuit-proof manner (e.g., as separate, unshielded cables or in separate cable ducts).

WARNING

The module only detects "wire break" and "overload" errors at the P switch (not at the M switch) of a digital output which drives two relays.

It is no longer possible to shut down an actuator if a cross-circuit has developed between the P and M switches of the output.

Note

The SM 236; DO 8 x DC 24V/2A PM carries out a bit pattern test ca. every 15 minutes. For this purpose, the module sends out a pulse for max. 4 ms. The module runs the test with a time offset between the P and M switches to prevent the actuator from being activated. This pulse may cause the corresponding relay to tighten, which may reduce its service life.

We therefore recommend adhering to the wiring scheme detailed below.

Prevention/control of cross circuits between the P and M switches

To control cross circuits between P and M switches of a fail-safe digital output, we recommend the following wiring variant:

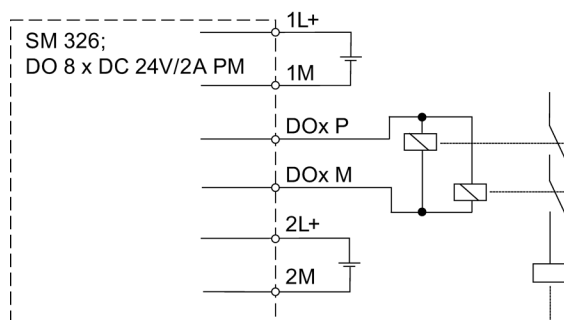

Figure 8-39 Wiring scheme 2 relays at digital output of SM 326; DO 8 x DC 24V/2A PM - Controlling cross circuits

Note

The module only detects a "wire break" fault at the P or M switch of its output if the both relays are wired separately to the P or M switches.

Assignable parameters for applications 1 and 2

Table 8- 16 Parameters of the SM 326; DO 8 x DC 24V/2A PM for applications 1 and 2

Parameters	Range of values	Type	Effective range
"Parameters" tab			
F parameter:			
F monitoring time	10 ms to 10000 ms	Static	Module
Module parameters:			
Diagnostic interrupt	Activated/deactivated	Static	Module
For single channels or channel pairs:			
Activated	Activated/deactivated	Static	Channel
Diagnostics: Wire break	Activated/deactivated	Static	Channel

8.5.4 Diagnostic messages of SM 326; DO 8 x DC 24V/2A PM [ID: 431676811]

Diagnosics using the LED display

The F-SM indicates faults by means of its SF LED (group fault LED). The SF LED is activated when the F-SM generates a diagnostic message.

The SF LED flashes as long as a cleared fault has not been acknowledged. It goes dark when all faults have been eliminated and acknowledged.

The SF LED flashes until you acknowledge passivation following a module fault.

Possible diagnostic messages

The following table provides an overview of the diagnostic messages for SM 326; DO 8 x DC 24V/2A PM.

Diagnostic messages are assigned either to a channel or to the entire module.

Table 8- 17 Diagnostic messages of SM 326; DO 8 x DC 24V/2A PM

Diagnostic message	Signaled in the application	Effective range of diagnostics	Assignable
Wire break	1, 2	Channel	Yes
DOx_P short-circuit of the output to M, or defective output driver			
DOx_M short-circuit of output to M, or defective output driver			
DOx_P short circuit of output to L+, or defective output driver			
DOx_M short circuit of output to L+, or defective output driver			
No external auxiliary voltage	1, 2	Module	No
Module parameters not assigned			
Incorrect module parameters			
Communication error			
Internal supply voltage of the module failed			
Time monitoring activated (watchdog)			
EPROM error			
RAM error			
Internal error in read circuit/test circuit or defective sensor supply			
Processor failure			
Parameter assignment error (with specification of a consecutive number)			
External load voltage missing			
Short-circuit at the load voltage			
Defective output driver			
Overtemperature at output driver			
Load voltage not connected			
Defective load voltage or load voltage not connected			
CRC signature error	1, 2	Module	
Timeout of safety message frame monitoring			

Causes of the problem and corrective measures

The table below shows the possible causes of the problem and associated corrective measures for the individual diagnostic messages of the SM 326, DO 8 x DC 24V/2A PM.

Table 8- 18 Diagnostic messages and associated corrective measures for SM 326; DO 8 x DC 24V/2A PM

Diagnostic message	Error detection	Possible causes of the problem	Corrective measures
Wire break	General	Wire break between the module and actuator	Restore the cable connection
		Channel not connected (open) or unused	Disable the "Group Diagnostics" for the channel in the parameter settings.
Short-circuit of output to M, or defective output driver	General	Output overload	Eliminate the cause of overload
		Short-circuit between the M output and M of the module power supply	Eliminate the short-circuit. Reset the module by cycling supply voltage 1L+ off/on
		Undervoltage at load voltage supply	Check the load voltage supply
		Defective output driver	Replace the module
Short circuit of output to L+, or defective output driver	General	Short-circuit between the output and L+ of the module power supply	Eliminate the short-circuit Module reset required (supply voltage 1L+ off/on)
		Short-circuit between channels which carry different signals	Eliminate the short-circuit Module reset required (supply voltage 1L+ off/on)
		Defective output driver	Replace the module
Short-circuit at the load; or defective output driver	General	Short-circuit at the load	Eliminate the short-circuit; reset of module required (supply voltage 1L+ off/on)
Defective output driver	General	Defective module	Replace the module
		Short-circuit at the output	Eliminate the short-circuit. Reset the module by cycling supply voltage 1L+ off/on
Overtemperature at output driver	General	Output overload	Eliminate the cause of overload
		Internal fault at output driver	Replace the module
External load voltage missing	General	Supply voltage 1L+ of module missing	Connect 1L+

Diagnostic message	Error detection	Possible causes of the problem	Corrective measures
Internal supply voltage of the module failed	General	Internal fault at supply voltage 1L+	Replace the module
Module parameters not assigned	General	No parameters transferred to module	Assign new module parameters
Defective load voltage or load voltage not connected	General	Load voltage 2L+, 3L not connected	Connect 2L+ and 3L+
		External fault at load voltage 2L+, 3L+	Replace the module
		Short-circuit between P and M	Eliminate the short-circuit
Incorrect module parameters	General	Wrong module	Check the module; replace; assign new parameters
Time monitoring activated (watchdog)	General	Overload due to diagnostics request (SFCs)	Reduce the number of diagnostics requests
		Electromagnetic interference has exceeded limits	Eliminate the interference
		Defective module	Replace the module
Communication error	General	Error in communication between the CPU and the module, for example, due to defective PROFIBUS connection or electromagnetic interference in excess of limits	Check the PROFIBUS connection Eliminate the interference
		Timeout of data frame monitoring	Check the monitoring time parameters
		CRC signature error, for example, due to electromagnetic interference in excess of limits.	Eliminate the interference
		CPU is in STOP	Read the diagnostics buffer
EPROM error RAM error	General	Electromagnetic interference has exceeded limits	Eliminate the interference and cycle power off/on
		Defective module	Replace the module
Internal error in read / test sequence	General	Defective module	Replace the module
Processor failure	General	Electromagnetic interference has exceeded limits	Eliminate the interference
		Defective module	Replace the module
		Switching rate exceeded	Reduce switching rate

Diagnostic message	Error detection	Possible causes of the problem	Corrective measures
Parameter assignment error (with specification of a consecutive number)	General	Error in dynamic parameter reassignment	Check the parameter assignment in the user program. Contact SIMATIC Customer Support if necessary
CRC signature error	General	CRC signature error during communication between the CPU and the module has occurred, for example, due to electromagnetic interference in excess, faults during sign-of-life monitoring error or standard program accesses F-SM.	Eliminate the interference
Timeout of safety message frame monitoring	General	Assigned monitoring time exceeded	Check the monitoring time parameters
		Startup of the fail-safe signal module	—

Note

Note that an inductive load connected to the DO channels can induce voltages due to interference of a strong, magnetic field. This situation can result in the error message short circuit.

Remedy:

Create a spatial separation of the inductive loads and shield the magnetic field.

8.5.5 Technical data - SM 326; DO 8 x DC 24V/2A PM [ID: 8680303115]

Overview

Technical specifications		
Dimensions and weight		
Dimensions W x H x D (mm)	80 x 125 x 120	
Weight	Approx. 465 g	
Module-specific specifications		
Number of outputs	8	
Assigned address area		
• In the I/O input area	5 bytes	
• In the I/O output area	5 bytes	
Cable length		
• Unshielded	Max. 200 m	
• Shielded	Max. 200 m	
Front connectors	40-pin	
Maximum achievable Safety Integrity Level in safety mode		
• According to IEC 61508:2000	SIL 3	
• According to ISO 13849-1:2006 or EN ISO 13849-1:2008	Cat. 4/PLe	
Fail-safe performance characteristics	SIL 2	SIL 3
• low demand mode (average probability of failure on demand)	< 1.00E-05	< 1.00E-05
• high demand / continuous mode (probability of a dangerous failure per hour)	< 1.00E-09	< 1.00E-09
Voltages, Currents, Potentials		
Rated supply voltage of the electronics 1L+	24 V DC	
• Reverse polarity protection	Yes	
Rated load voltage 2L+/3L+	24 V DC	
• Reverse polarity protection	No	
Aggregate current of outputs per group		
• Horizontal installation Up to 40 °C Up to 60 °C	Max. 7.5 A Max. 5 A	
• Vertical installation Up to 40 °C	Max. 5 A	
Electrical isolation		
• Between channels and backplane bus	Yes	

Technical specifications	
• Between channels and the power supply of the electronics	Yes
• Between channels In groups of	Yes 4
Maximum potential difference between different circuits	75 V DC 60 V AC
Insulation test voltage	500V DC / 350V AC for 1 min or 600V DC for 1s
Current consumption	
• From backplane bus	Max. 100 mA
• From supply voltage 1L+	Max. 75 mA
• From load voltage 2L+/ 3L+ (no-load)	Max. 100 mA
Power loss of the module	12 W, typical
Status, Interrupts, Diagnostics	
Status display	Green LED per channel
Interrupts	
• Diagnostic interrupt	Configurable
Diagnostics functions	Configurable
• Group fault display	Red LED (SF)
• Fail-safe mode display	Green LED (SAFE)
• Diagnostic information can be read out	Possible
Sensor selection data	
Output voltage	
• For "1" signal	Minimum L+ (-1.0 V)
Output current	
• Rated value with "1" signal	2 A
Permissible range to 40 °C, horizontal installation	7 mA to 2 A
Permissible range to 40 °C, vertical installation	7 mA to 1 A
Permissible range to 60 °C, horizontal installation	7 mA to 1 A
• For "0" signal (residual current)	Max. 0.5 mA
Load resistance range	
• Up to 40 °C	12 Ω to 3.4 kΩ
• Up to 60 °C	24 Ω to 3.4 kΩ
Lamp load	Max. 5 W
Control of a digital input	Not possible
Switching frequency	
• With resistive load	Max. 30 Hz

Technical specifications	
• With inductive load in accordance with IEC 60947-5-1, DC 13	Max. 2 Hz
• With lamp load	Max. 10 Hz
Internal limit of the inductive shutdown voltage	Typical L+ (-33 V)
Short-circuit protection of output	Yes, electronic
• Response threshold	2.6 to 4.5 A
Actuator timing requirements	Actuator must not react within dark period < 1 ms (see also section "Sensor and Actuator Requirements for F-SMs in Safety Mode (Page 50)")
Wire break detection	
• For "1" signal	1 s
• For "0" signal	100 s
Time, Frequency	
Internal signal preparation time in safety mode	Min. 4 ms Max. 14 ms
Acknowledgment time in safety mode	Max. 18 ms

Note

The maximum cable lengths currently specified in this manual ensure against functional impairment, even without more precise examination of the boundary conditions. If the boundary conditions, such as EMC, cable type, cable routing, etc. are examined more closely, longer cables can be used for all F-SMs.

8.6 SM 326; DO 10 x DC 24V/2A (6ES7326-2BF01-0AB0)

8.6.1 Properties, front view, wiring diagram and block diagram [ID: 431684619]

Order number

6ES7326-2BF01-0AB0

Properties

SM 326; DO 10 x DC 24V/2A has the following properties:

- 10 outputs, two electrically isolated groups of 5
- Output current 2 A
- Rated load voltage 24 V DC
- Suitable for solenoid valves, DC relay contactors, and signal lamps
- 2 connections per output:
 - One connection for single-channel actuator control (without series diode)
 - One connection for redundant actuator control (with series diode)
- Group fault display (SF)
- Safety mode display (SAFE)
- Status display for each channel (green LED)
- Programmable diagnostics functions
- Programmable diagnostic interrupt
- Assignable fail-safe value output in standard mode
- Supports operation in standard and safety mode

Note

The fail-safe performance characteristics in the technical data apply to a proof-test interval of 10 years and a mean time to repair of 100 hours.

Redundant output signals

WARNING

An output with series diode can be used for redundant control of an actuator. Redundant control is supported for two different modules and without an external circuit. The two signal modules must be connected to the same reference potential (M).

Note

Connect the SM 326; DO 10 x DC 24V/2A to the same load voltage for operation in redundant mode. Install two redundant power supply units if a single power supply is insufficient for reasons of availability. The power supply units must be coupled by means of diode circuit.

Short-circuit to L+ at redundant interconnection

WARNING

Prevent short circuits to L+ at the SM 326; DO 10 x DC 24V/2A with protected routing of the signal lines.

The module may not be able shut down the actuator by switching off the corresponding redundant output if a short-circuit to L+ is active.

Address assignment

Check the output address in the user program:

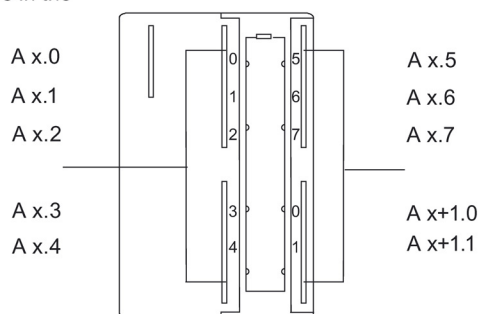

x = Module start address

Figure 8-40 Address assignment for SM 326; DO 10 x DC 24V/2A

Front view

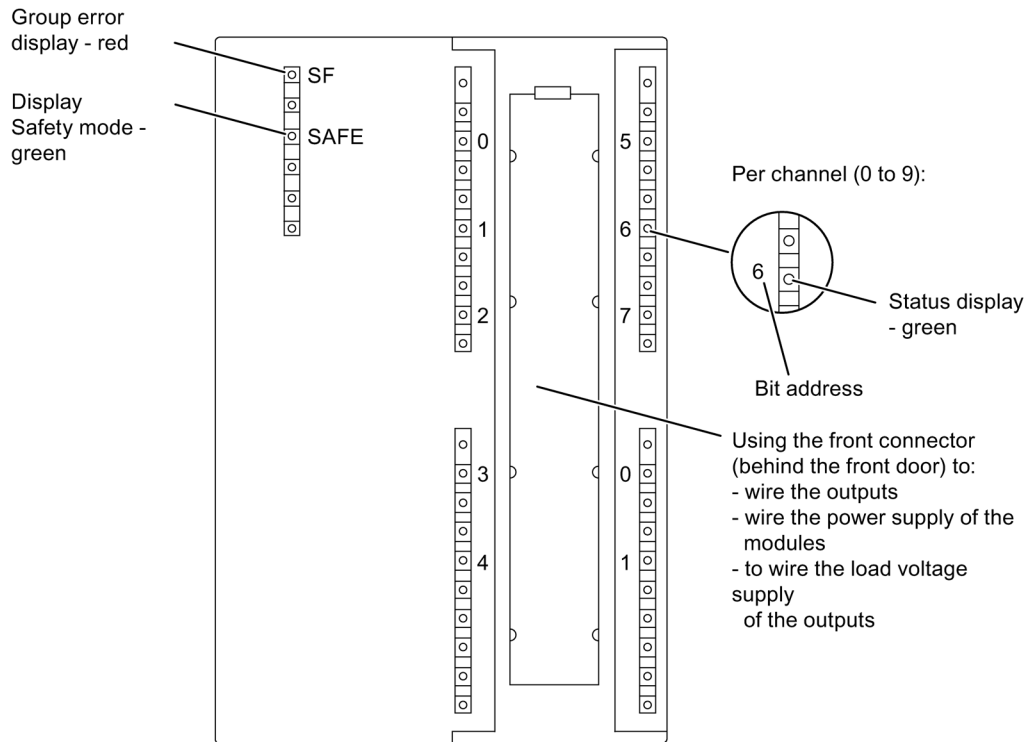

Figure 8-41 Front view of SM 326; DO 10 x DC 24V/2A

Wiring and block diagram

The following figure shows the the wiring and block diagram of SM 326; DO 10 x DC 24V/2A.

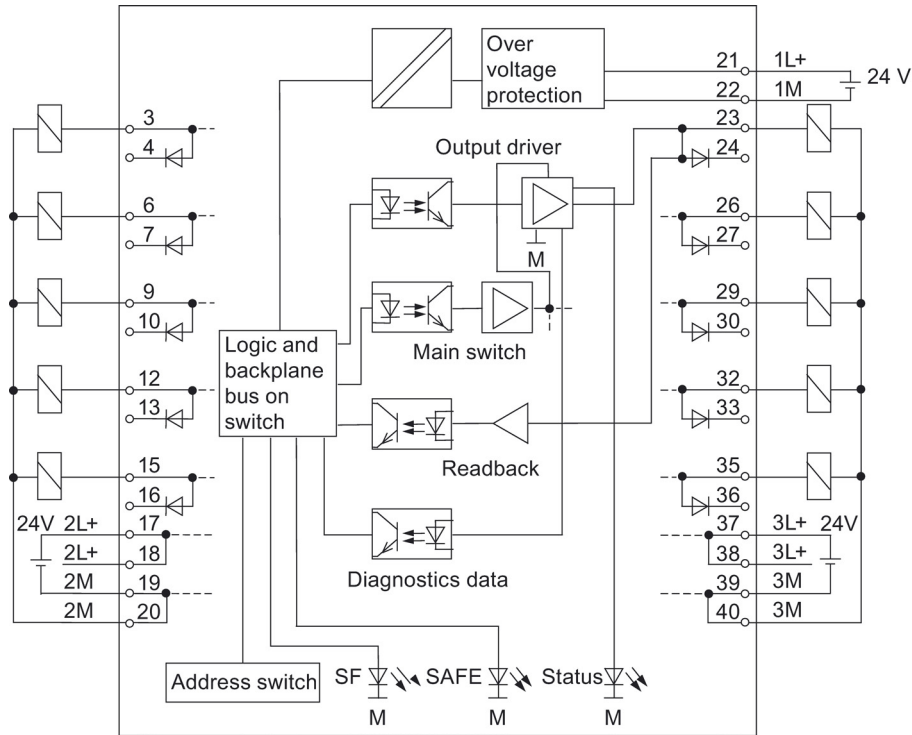

Figure 8-42 Wiring and block diagram of SM 326; DO 10 x DC 24V/2A

The potential groups 1L+, 2L+ and 3L+ can be supplied by separated power supply units but also by one common power supply unit.

Channel numbers

The channel numbers are used to identify the outputs and to assign channel-specific diagnostic messages.

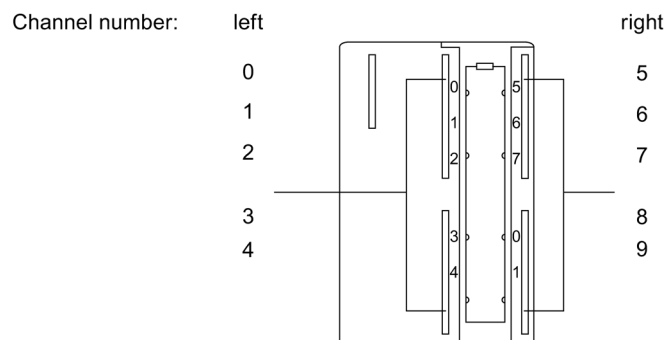

Figure 8-43 Channel numbers for SM 326; DO 10 x DC 24V/2A

8.6.2 SM 326; DO 10 x DC 24V/2A applications [ID: 431687307]

Selecting the application

The figure below helps you to select an application based on availability and fail-safe operation requirements. The next pages provide information on the module wiring for a specific application, and on the parameters to set in *STEP 7* using the *S7 Distributed Safety* or *S7 F Systems* optional package.

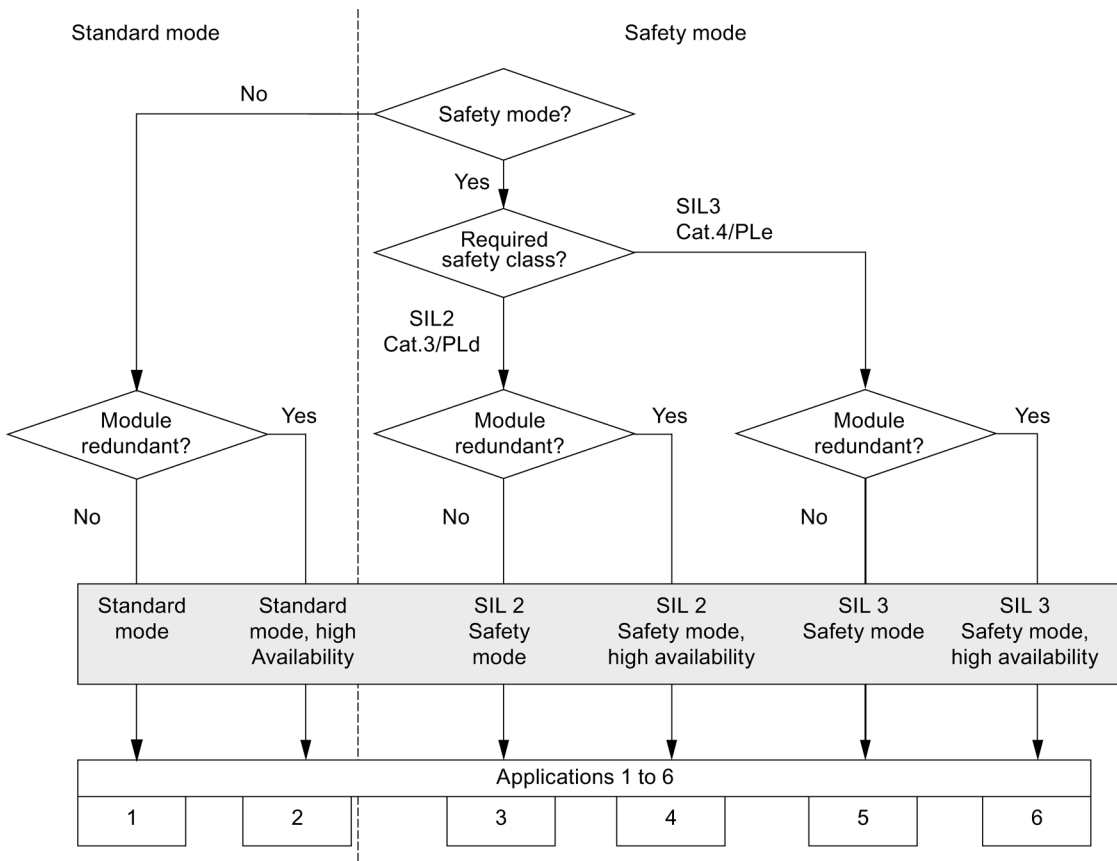



Figure 8-44 SM 326; DO 10 x DC 24V/2A - Selecting an application

Avoiding dark periods when operating in safety mode

 WARNING
<p>If you are using actuators that respond too fast (i.e. < 1 ms) to "dark period" test signals, you can nonetheless use the internal test coordination by wiring two opposite outputs in parallel using a series diode. Parallel wiring suppresses the dark periods.</p>

See also

Parallel Connection of Two Outputs for Dark Period Suppression (Page 159)

8.6.3 Application 1: Standard mode, application 3: Safety Mode SIL2/Cat.3/PLd and application 5: Safety mode SIL3/Cat.4/PLe [ID: 431689995]

Introduction

Below are the wiring scheme and the parameter assignment of SM 326; DO 10 x DC 24V/2A for

- Application 1: standard mode,
- Application 3: Safety mode SIL2/Cat.3/PLd and
- Application 5: Safety mode SIL3/Cat.4/PLe.

Diagnostic messages, possible causes of the problem and their corrective measures are found in tables in the chapter "Diagnostics messages of SM 326; DO 10 x DC 24V/2A (Page 160)".

Note

In case of parameter setting with SIL3

The signal at the output has to change daily or even more frequently. If this is not the case with the "0" signal, you will have to activate the light test that meets this condition.

Wiring scheme for applications 1, 3 and 5

Single-channel connection of one sensor for each process signal. The load voltage supply is wired to terminals 2L+/2M, 3L+/3M of the digital module.

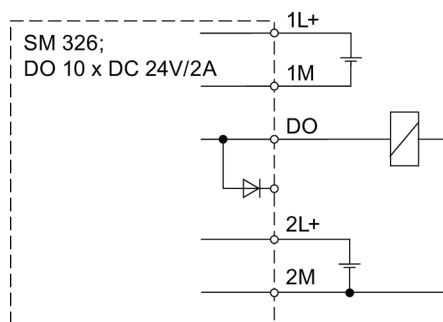

Figure 8-45 Wiring scheme of the SM 326; DO 10 x DC 24V/2A for applications 1, 3 and 5

WARNING

It is no longer possible to shut down an actuator if a cross circuit has developed between 2L+ and DO. To prevent cross circuits between 2L+ and DO, you must route the cables used to connect the actuators between the two signal groups (channels 0 - 4 and channels 5 - 9) in a cross-circuit-proof manner (for example, as separate, sheathed cables or in separate cable ducts).

Connecting two actuators to one digital output

The fail-safe digital output is capable of switching two actuators. The following conditions have to be met:

- Wire L+ and M of the actuators to 2L+ and 2M of the module (same reference potential required).

The actuators can be wired to any one of the 10 digital outputs. The figure below shows an example of an output wiring. This circuit is compliant with SIL 3/Cat. 4/PLe.

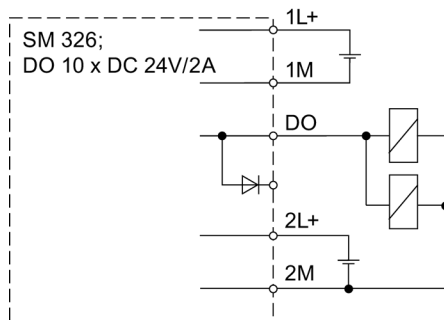

Figure 8-46 Wiring scheme 2 actuators at digital output of SM 326; DO 10 x DC 24V/2A

⚠ WARNING

It is no longer possible to shut down an actuator if a cross circuit has developed between 2L+ and DO. To prevent cross circuits between 2L+ and DO, you must route the cables used to connect the actuators between the two signal groups (channels 0 - 4 and channels 5 - 9) in a cross-circuit-proof manner (for example, as separate, sheathed cables or in separate cable ducts).

Assignable parameters for applications 1, 3 and 5

Table 8- 19 Parameters of the SM 326; DO 10 x DC 24V/2A for applications 1, 3 and 5

Parameters	Range of values		Type	Effective range
	Safety mode	Standard mode		
"Outputs" tab				
Enable diagnostic interrupt	Activated/deactivated	Activated/deactivated	Static	Module
Mode	<ul style="list-style-type: none"> • Safety mode according to SIL 2 • Safety mode according to SIL 3 	Standard mode	Static	Module
Monitoring time	10 ms to 10000 ms	—	Static	Module
Disable light test	Activated/deactivated	Activated/deactivated	Static	Module
Reaction during CPU STOP	—	<ul style="list-style-type: none"> • Switch to fail-safe value • Keep last valid value 	Static	Module
Group diagnostics	Activated/deactivated	Activated/deactivated	Static	Channel
Switch to fail-safe value "1"	—	Activated/deactivated	Static	Channel
"Redundancy" tab				
Redundancy	none	—	Static	Module

8.6.4 Application 2: standard mode with high availability, application 4: Safety Mode SIL2/Cat.3/PLd with high availability and application 6: Safety mode SIL3/Cat.4/PLe with high availability (in S7 F/FH Systems only) [ID: 431698059]

Introduction

Below are the wiring scheme and the parameter assignment of SM 326; DO 10 x DC 24V/2A for

- Application 2: standard mode with high availability
- application 4: Safety mode SIL2/Cat.3/PLd with high availability
- Application 6: Safety mode SIL3/Cat.4/PLe with high availability

Diagnostic messages, possible causes of the problem and their corrective measures are found in tables in the chapter "Diagnostics messages of SM 326; DO 10 x DC 24V/2A (Page 160)".

Note

In case of parameter setting with SIL3

The signal at the output has to change daily or even more frequently. If this is not the case with the "0" signal, you will have to activate the light test that meets this condition.

Wiring scheme for applications 2, 4 and 6

Each process signal requires one actuator which is controlled redundantly by the two digital modules. The load voltage supply is wired to terminals 2L+/2M, 3L+/3M of the digital module.

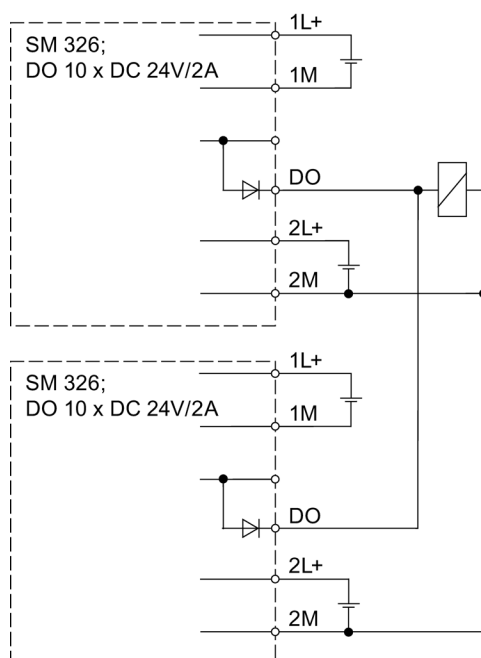

Figure 8-47 Wiring scheme of the SM 326; DO 10 x DC 24V/2A for applications 2, 4 and 6

Assignable parameters for applications 2, 4 and 6

Table 8- 20 Parameters of the SM 326; DO 10 x 24V/2A for applications 2, 4 and 6

Parameters	Range of values		Type	Effective range
	Safety mode	Standard mode		
"Outputs" tab				
Enable diagnostic interrupt	Activated/deactivated	Activated/deactivated	Static	Module
Mode	<ul style="list-style-type: none"> Safety mode according to SIL 2 Safety mode according to SIL 3 	Standard mode	Static	Module
Monitoring time	10 ms to 10000 ms	—	Static	Module
Disable light test	Activated/deactivated	Activated/deactivated	Static	Module
Reaction during CPU STOP	—	<ul style="list-style-type: none"> Switch to fail-safe value Keep last valid value 	Static	Module
Group diagnostics	Activated/deactivated **	Activated/deactivated	Static	Channel
Switch to fail-safe value "1"	—	Activated/deactivated	Static	Channel
"Redundancy" tab				
Redundancy	2 modules	— *	Static	Module
Redundant module	(selection of an existing additional module of the same type)	—	Static	Redundant Module pair
<p>* There are two digital values in the case of redundant configuration in standard mode; you must evaluate them in the standard user program.</p> <p>** If you have selected "no", keep track of the repair time.</p>				

8.6.5 Parallel Connection of Two Outputs for Dark Period Suppression [ID: 431692683]

Applications

All applications (3, 4, 5 and 6) support parallel operation of two outputs for dark period suppression in safety mode.

Wiring scheme

Interconnect two *opposite outputs* by means of a series diode in order to form a single output. The parallel circuit in combination with an internal test coordination between the outputs 0 to 4 and 5 to 9 suppresses the "0" test pulse (dark period).

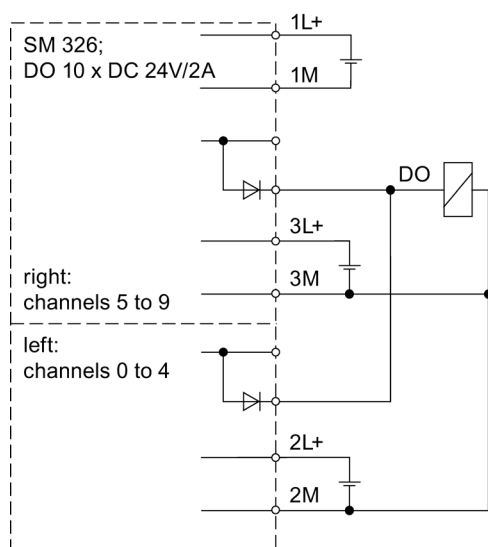

Figure 8-48 Wiring two outputs in parallel for dark period suppression of the SM 326; DO 10 x DC 24V/2A

You assign the fail-safe signal module parameters as described for the various applications on the previous pages. The interconnection does not require any additional parameters.

Always set the interconnected outputs in parallel instead of setting only one output. Process signals of a redundant I/O system require four outputs with series diode.

8.6.6 Diagnostics messages of SM 326; DO 10 x DC 24V/2A [ID: 431700747]

Possible diagnostic messages

The following table provides an overview of the diagnostic messages for SM 326; DO 10 x DC 24V/2A.

Diagnostic messages are assigned either to a channel or to the entire module. Some diagnostic messages occur only in certain applications.

Table 8- 21 Diagnostic messages of SM 326; DO 10 x DC 24V/2A

Diagnostic message	Signaled in the application	Effective range of diagnostics	Assignable		
Wire break	1, 2, 3, 4, 5, 6	Channel	Yes		
Short-circuit of output to M, or defective output driver			No		
Short-circuit of output to L+ or defective output driver *	Module				
Module parameters not assigned	1, 2, 3, 4, 5, 6	Module			
Incorrect module parameters					
Communication error					
Internal supply voltage of the module failed					
Time monitoring activated (watchdog)					
EPROM fault; RAM fault					
Internal error in read circuit/test circuit, or defective sensor supply					
Processor failure					
Parameter assignment error (with specification of a consecutive number)					
No external auxiliary voltage					
External load voltage missing					
Defective main switch					
Defective output driver					
Overtemperature at output driver					
Defective load voltage or load voltage not connected				Channel group	
CRC signature error				3, 4, 5, 6	Module
Timeout of safety message frame monitoring					
Message frame error	1, 2	Module			

*The module is passivated. The module immediately shuts down and returns a "Processor failure" error message if a repeated short-circuit is detected.

Causes of the problem and corrective measures

The table below shows possible causes of the problem and appropriate corrective measures for the individual diagnostic messages of SM 326, DO 10 x DC 24V/2A.

Table 8- 22 Diagnostic messages and associated corrective measures for SM 326; DO 10 x DC 24V/2A

Diagnostic message	Error detection	Possible causes of the problem	Corrective measures
Wire break	Only if the output = 1 or during light period test	Wire break between the module and actuator	Restore the cable connection
		Channel not connected (open)	Disable the "Group Diagnostics" for the channel in the parameter settings.
		At outputs with series diode: short-circuit between the output and 1L+ of the module supply	Eliminate the short-circuit
		At outputs with series diode: short-circuit between channels which carry different signals	Eliminate the short-circuit
Short-circuit of output to M, or defective output driver	Only if the output = 1 or during light period test	Output overload	Eliminate the cause of overload
		Short-circuit to M at the output	Eliminate the short-circuit
		Undervoltage at load voltage supply	Check the load voltage supply
		Defective output driver	Replace the module
Short circuit of output to L+, or defective output driver	Only if "1" signal is set at the output without series diode or at an output with series diode and internal short-circuit to L+	Short-circuit of output after 1L+ of the module power supply	Eliminate the short-circuit Module reset required (cycle power supply off/on)
		Short-circuit between channels which carry different signals	Eliminate the short-circuit Module reset required (cycle power supply off/on)
		Defective output driver	Replace the module
Module parameters not assigned	General	No parameters transferred to module	Assign new module parameters
Incorrect module parameters	General	Faulty parameters transferred to module	Assign new module parameters
Internal supply voltage of the module failed	General	Internal fault at supply voltage 1L+	Replace the module
Time monitoring activated (watchdog)	General	Overload due to diagnostics request (SFCs)	Reduce the number of diagnostics requests
		Electromagnetic interference has exceeded limits	Eliminate the interference

Diagnostic message	Error detection	Possible causes of the problem	Corrective measures
		Defective module	Replace the module
Communication error	General	Error in communication between the CPU and the module, for example, due to defective PROFIBUS connection or electromagnetic interference in excess of limits.	Check the PROFIBUS connection Eliminate the interference
		Timeout of data frame monitoring	Check the monitoring time parameters
		CRC signature error, for example, due to electromagnetic interference in excess of limits.	Eliminate the interference
		CPU is in STOP	Read the diagnostics buffer
EPROM error RAM error	General	Electromagnetic interference has exceeded limits	Eliminate the interference and cycle power supply OFF/ON
		Defective module	Replace the module
Internal error in read / test sequence	General	Defective module	Replace the module
Processor failure	General	Electromagnetic interference has exceeded limits	Eliminate the faults, and then remove and insert the module
		Defective module	Replace the module
		Switching rate exceeded	Reduce switching rate
Parameter assignment error (with specification of a consecutive number)	General	Error in dynamic parameter reassignment	Check the parameter assignment in the user program. Contact SIMATIC Customer Support if necessary
No external auxiliary voltage	General	Supply voltage 1L+ of module missing	Connect 1L+
External load voltage missing	General	Supply voltage 1L+ of module missing	Feed in voltage supply
Defective main switch	General	Defective module	Replace the module
Defective output driver	General	Defective module	Replace the module
Overtemperature at output driver	General	Output overload	Eliminate the cause of overload
		Internal fault at output driver	Replace the module
Defective load voltage or load voltage not connected	General	Load voltage 2L+, 3L not connected	Connect 2L+ and 3L+
		Load voltage external error	Replace the module

Diagnostic message	Error detection	Possible causes of the problem	Corrective measures
CRC signature error	General	CRC signature error during communication between the CPU and the module has occurred, for example, due to electromagnetic interference in excess, faults during sign-of-life monitoring error, in case of voltage drop or standard program accesses F-SM.	Eliminate the interference
Timeout of safety message frame monitoring	General	Assigned monitoring time exceeded	Check the monitoring time parameters
		Startup of the fail-safe signal module	—
Message frame error	General	Sign-of-life and/or CRC signature entered in the data message frame	Check the sign-of-life and CRC signature entries in the data message frame for "0" value

Incorrect diagnostics of a wire break at the redundant digital output modules

Redundant operation of fail-safe output modules SM 326; DO 10 x DC 24V/2A can result in the following behavior in case of an error: In addition to reporting a wire break and the corresponding faulty channel, the module also reports faults at one or several other channels if operating with **different load circuits**.

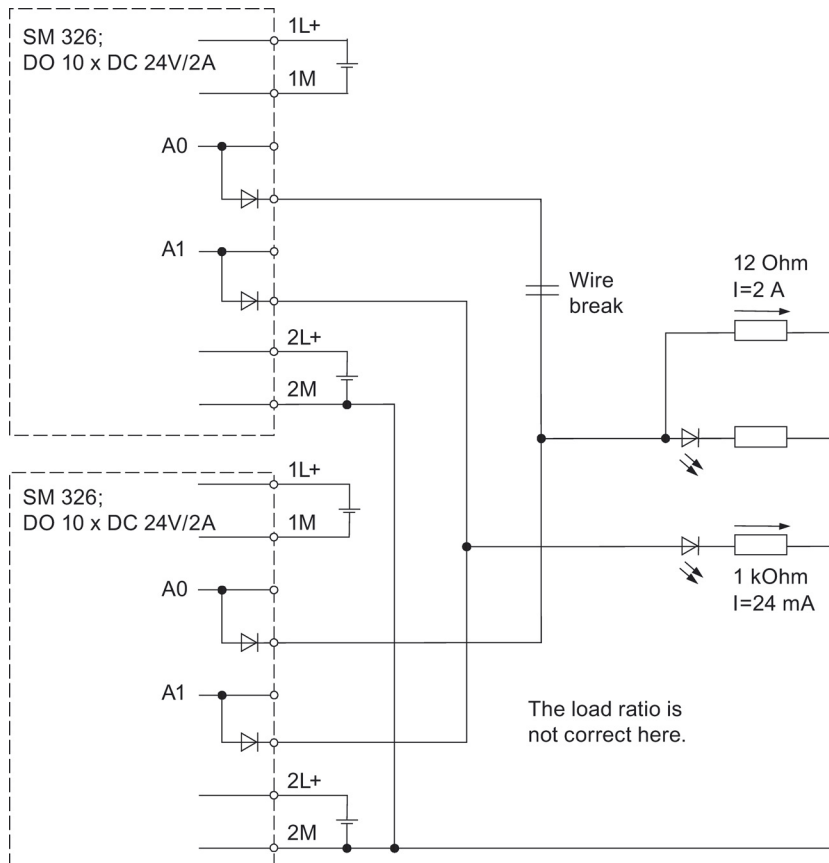

Figure 8-49 Incorrect diagnostics of a wire break at the redundant SM 326; DO 10 x DC 24V/2A

Example

The module in this example reports faults at channels Q0 and Q1 after having detected a wire break at Q0. This is caused by severe load differences between the two channels: 2 A and 24 mA.

Remedy

The load at the output channels of the module should be close to equal in order to obtain correct diagnostics data. That is, a low-to-high load ratio of at least 1:5 should be maintained.

Faulty diagnostics in case of short-circuit

When the fail-safe digital output module SM 326; DO 10 x DC 24V/2A detects a short-circuit to L+ at a channel, or a short-circuit between channels which carry different signals, it generates a diagnostic interrupt to report and passivate the faulty channel, including all other channels in the section which contain this channel. Any short-circuit of longer duration leads to the total failure of the module.

See also

Parallel Connection of Two Outputs for Dark Period Suppression (Page 159)

8.6.7 Technical Data - SM 326; DO 10 x DC 24V/2A [ID: 8680616331]

Overview

Technical specifications		
Dimensions and weight		
Dimensions W x H x D (mm)	80 x 125 x 120	
Weight	Approx. 465 g	
Module-specific specifications		
Number of outputs	10	
Assigned address area		
• In the I/O input area	6 bytes	
• In the I/O output area	8 bytes	
Cable length		
• Unshielded	Max. 600 m	
• Shielded	Max. 1000 m	
• with SIL3/Cat.4/PLe	Max. 200 m	
Front connectors	40-pin	
Maximum achievable Safety Integrity Level in safety mode		
• According to IEC 61508:2000	SIL 3	
• According to ISO 13849-1:2006 or EN ISO 13849-1:2008	Cat. 4/PLe	
Fail-safe performance characteristics	SIL 2	SIL 3
• low demand mode (average probability of failure on demand)	< 1.00E-05	< 1.00E-05
• high demand / continuous mode (probability of a dangerous failure per hour)	< 1.00E-09	< 1.00E-09
Voltages, Currents, Potentials		
Rated supply voltage of the electronics 1L+	24 V DC	
• Reverse polarity protection	Yes	
Rated load voltage 2L+/3L+	24 V DC	
• Reverse polarity protection	No	
Accumulated current of outputs without series diode (per group)		
• Horizontal installation Up to 40 °C Up to 60 °C	Max. 7.5 A Max. 5 A	
• Vertical installation Up to 40 °C	Max. 5 A	
Accumulated current of outputs with series diode (per group)		

Technical specifications	
<ul style="list-style-type: none"> Horizontal installation Up to 40 °C Up to 60 °C 	Max. 5 A Max. 4 A
<ul style="list-style-type: none"> Vertical installation Up to 40 °C 	Max. 4 A
Electrical isolation	
<ul style="list-style-type: none"> Between channels and backplane bus 	Yes
<ul style="list-style-type: none"> Between channels and the power supply of the electronics 	Yes
<ul style="list-style-type: none"> Between channels In groups of 	Yes 5
Permitted potential difference Between different circuits	75 V DC 60 V AC
Insulation test voltage	500V DC / 350V AC for 1min or 600V DC for 1s
Current consumption	
<ul style="list-style-type: none"> From backplane bus 	Max. 100 mA
<ul style="list-style-type: none"> From supply voltage 1L+ 	Max. 70 mA
<ul style="list-style-type: none"> From load voltage 2L+ / 3L+ (no-load) 	Max. 100 mA
Power loss of the module	12 W, typical
Status, Interrupts, Diagnostics	
Status display	Green LED per channel
Interrupts	
Diagnostic interrupt	Configurable
Diagnostics functions	Configurable
Group fault display	Red LED (SF)
Fail-safe mode display	Green LED (SAFE)
Diagnostic information can be read out	Possible
Fail-safe values can be switched to	Yes, only in standard mode
Actuator selection data	
Output voltage	
<ul style="list-style-type: none"> For "1" signal Without series diode With series diode 	Minimum L+ (-1.0 V) Minimum L+ (-1.8 V)

Technical specifications	
Output current	
<ul style="list-style-type: none"> For "1" signal 	
Rated value	2 A
Permissible Range to 40°C, horizontal mounting position	7 mA to 2 A
Permissible Range to 40°C, vertical mounting position	7 mA to 1 A
Permissible Range to 60°C, horizontal mounting position	28 mA to 2 A
Permissible range with redundant interconnection to 40°C, horizontal mounting position	28 mA to 1 A
Permissible range with redundant interconnection to 40°C, vertical mounting position	28 mA to 1 A
Permissible range with redundant interconnection to 60°C, horizontal mounting position	
<ul style="list-style-type: none"> For "0" signal (residual current) 	Max. 0.5 mA
Load resistance range	
<ul style="list-style-type: none"> Up to 40 °C 	12 Ω to 3.4 kΩ
<ul style="list-style-type: none"> Up to 60 °C 	24 Ω to 3.4 kΩ
Lamp load	Max. 5 W
Parallel switching of 2 outputs	
<ul style="list-style-type: none"> For redundant load control 	Only outputs with series diode; outputs must be connected to common reference potential
<ul style="list-style-type: none"> For power increase 	Not possible
Control of a digital input	Possible
Switching frequency	
<ul style="list-style-type: none"> With resistive load 	Max. 10 Hz
<ul style="list-style-type: none"> With inductive load in accordance with IEC 60947-5-1, DC 13 	Max. 2 Hz
<ul style="list-style-type: none"> With lamp load 	Max. 10 Hz
Internal limit of the inductive shutdown voltage	
<ul style="list-style-type: none"> With series diode 	Typical L+ (-33 V)
<ul style="list-style-type: none"> Without series diode 	Typical L+ (-53 V)
Short-circuit protection of output	Yes, electronic
<ul style="list-style-type: none"> Response threshold 	2.6 to 4.5 A
<ul style="list-style-type: none"> Response threshold of redundant interconnection 	5.2 to 9 A

Technical specifications	
Actuator timing requirements	Actuator must not respond if: <ul style="list-style-type: none"> • Dark period < 1 ms • Light period < 1 ms (refer to section "Sensor and Actuator Requirements for F-SMs in Safety Mode (Page 50)")
Time, Frequency	
Internal preparation time for	
Standard mode	Max. 22 ms
Safety mode	Max. 24 ms
Acknowledgment time	
• In safety mode	Max. 20 ms

Note

The maximum cable lengths currently specified in this manual ensure against functional impairment, even without more precise examination of the boundary conditions. If the boundary conditions, such as EMC, cable type, cable routing, etc. are examined more closely, longer cables can be used for all F-SMs.

8.7 SM 326; F-DO 10 x DC 24V/2A PP (6ES7326-2BF10-0AB0)

8.7.1 Properties, front view, wiring diagram and block diagram [ID: 14338158091]

Order number

6ES7326-2BF10-0AB0

Properties

SM 326; F-DO 10 x DC 24V/2A PP has the following properties:

- 10 outputs, two electrically isolated groups of 5
- Output current 2 A
- Rated load voltage 24 V DC
- Protection against short circuit and overload
- Suitable for solenoid valves, DC relay contactors, and signal lamps
- Assignable redundant operation
- Operation in safety mode
- SIL3/Cat.4/PLe can be achieved without safety protector
- Group fault display (SF)
- Safety mode display (SAFE)
- Status display for each channel (green LED)
- Display of channel-specific errors (red LED)
- Programmable diagnostics functions
- Programmable diagnostic interrupt
- Firmware update via *HW Config*
- I&M identification data
- can be used with PROFINET IO
- "Keep last valid value" parameter
- Simplified redundant circuit
- Channel-selective passivation

Note

The fail-safe performance characteristics in the technical data apply to a proof-test interval of 20 years and a mean time to repair of 100 hours.

"Keep last valid value" parameter setting

 WARNING
<p>If "Keep last valid value" has been assigned, the last valid process value 0 or 1 will be retained with events such as abort of PROFIsafe communication or F-CPU stop.</p> <p>For more information, refer to the section entitled "Fault reactions in safety mode with parameter setting "Keep last valid value" (Page 57)".</p>

Address assignment

Check the output address in the user program:

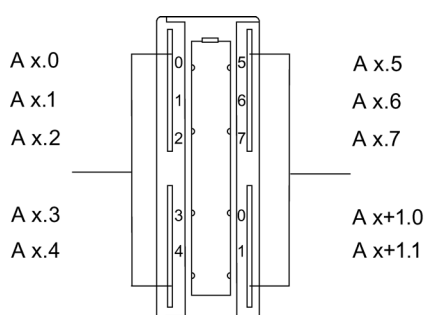

x = Module start address

Figure 8-50 Address assignment for SM 326; F-DO 10 x DC24V/2A PP

Front view

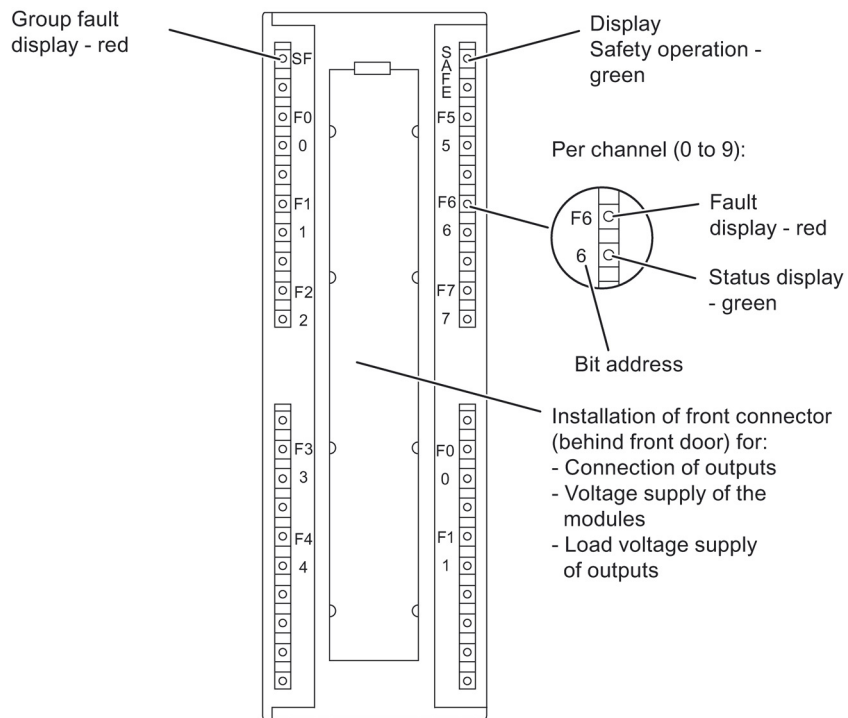

Figure 8-51 Front view of SM 326; F-DO 10 x DC 24V/2A PP

Wiring and block diagram

The following figure shows the wiring and block diagram of SM 326; F-DO 10 x DC 24V/2A PP.

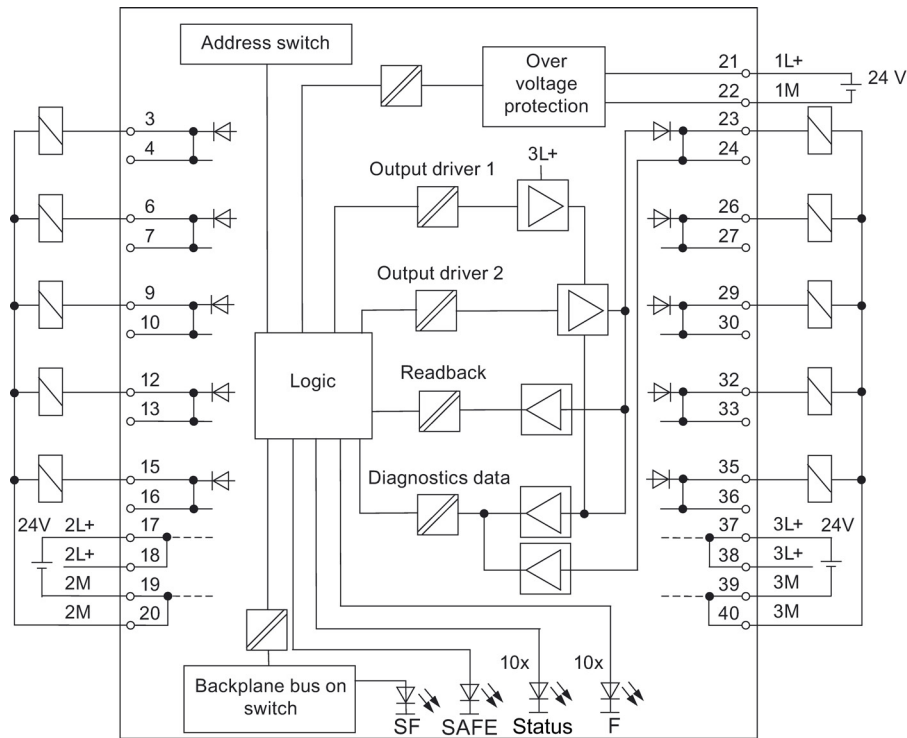

Figure 8-52 Wiring and block diagram of SM 326; F-DO 10 x DC 24V/2A PP

The potential groups 1L+, 2L+ and 3L+ can be supplied by separated power supply units but also by one common power supply unit.

Channel numbers

The channel numbers are used to identify the outputs and to assign channel-specific diagnostic messages.

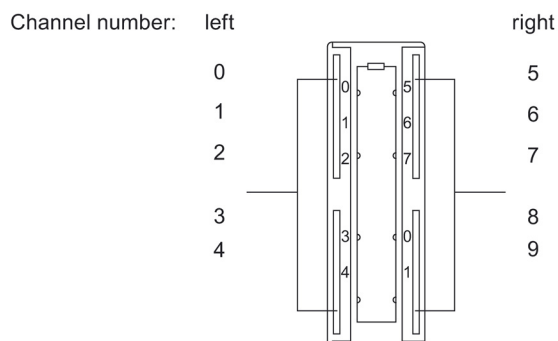

Figure 8-53 Channel numbers for SM 326; F-DO 10 x DC 24V/2A PP

8.7.2 SM 326; F-DO 10 x DC 24V/2A PP applications [ID: 14338158859]

Selecting the application

The figure below helps you to select an application based on availability and fail-safe operation requirements. The next pages provide information on the module wiring for a specific application, and on the parameters to set in *STEP 7* using the *S7 Distributed Safety* or *S7 F Systems* optional package.

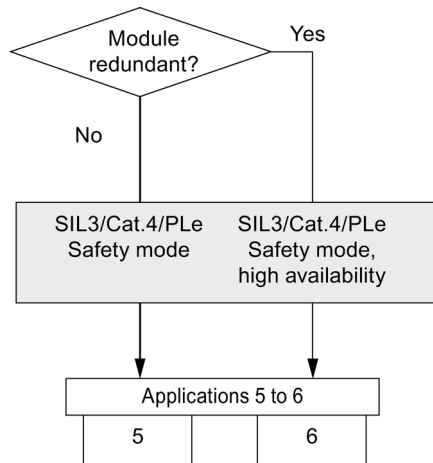

Figure 8-54 Application Selection - SM 326; F-DO 10 x DC 24V/2A PP

Test pulses of the light and dark test

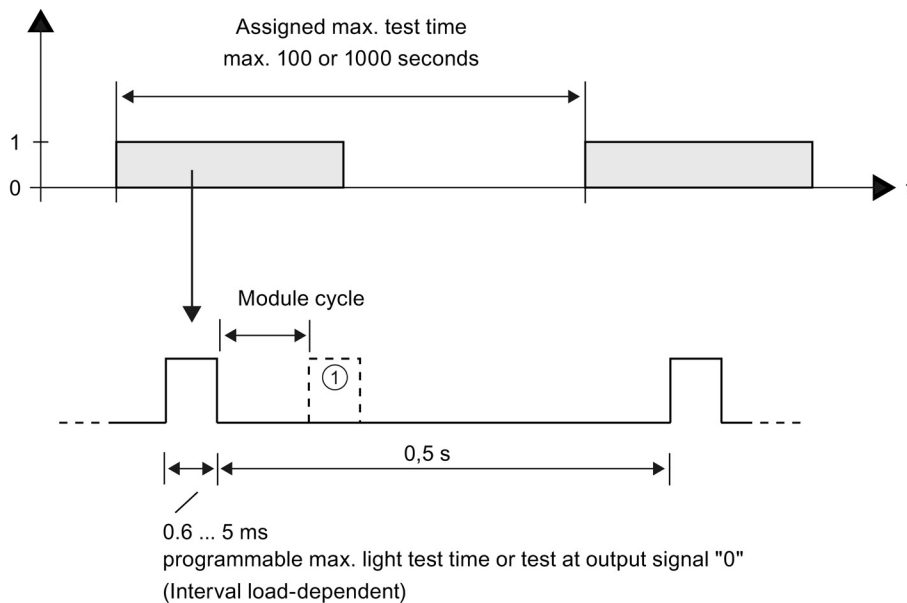

Figure 8-55 Light test, if assigned

The typical break between two test pulses is 0.5 seconds. There can be another test pulse ① in between. The gap between the first test pulse and the additional test pulse is one module cycle.

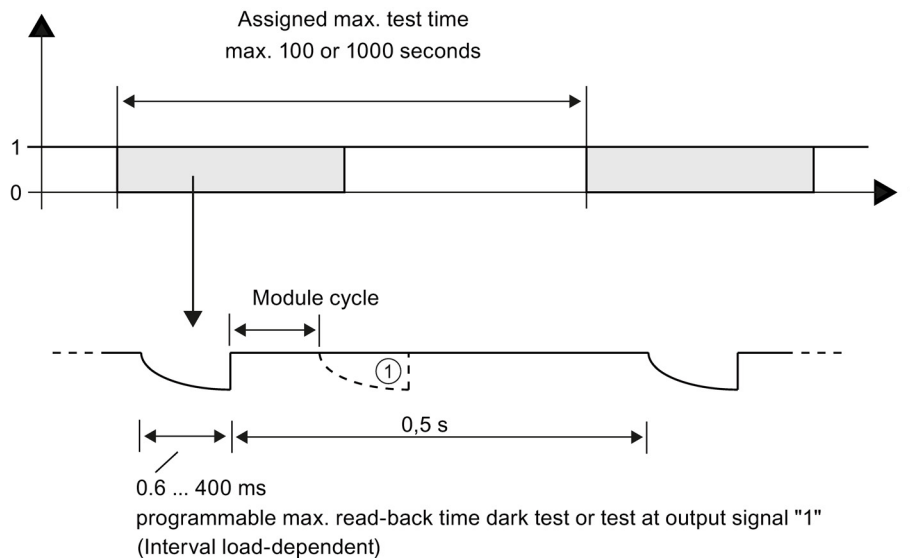

Figure 8-56 Dark test

The typical break between two test pulses is 0.5 seconds. There can be another test pulse ① in between. The gap between the first test pulse and the additional test pulse is one module cycle.

With redundant interconnection, both modules conduct the light and dark test in an asynchronous manner. This can result in an overlap of the test pulses.

Avoiding dark periods when operating in safety mode

Note

If you are using actuators that respond too fast (i.e. < 1 ms) to "dark period" test signals, you can nonetheless use the internal test coordination by wiring two opposite outputs (with assigned redundancy) in parallel using a series diode. Parallel wiring suppresses the dark periods. For more information, refer to the chapter "Application 5.1: Wiring two outputs in parallel for dark period suppression (Page 179)".

8.7.3 Applications 1 to 4 [ID: 15039296779]

Applications 1 and 2 are omitted because the module supports only safety mode.

Applications 3 and 4 are omitted because the module supports SIL3/Cat.4/PLe.

8.7.4 Application 5: Safety mode SIL3/Cat.4/PLe [ID: 14338159627]

Introduction

Below are the wiring scheme and the parameter assignment of SM 326; F-DO 10 x DC 24V/2A PP for

- Application 5: Safety mode SIL3/Cat.4/PLe.

Diagnostic messages, possible causes of the problem and their corrective measures are found in tables in the chapter "Diagnostic messages SM 326; F-DO 10 x DC 24V/2A PP (Page 185)".

Note

In case of parameter setting with SIL3

The signal at the output has to change daily or even more frequently. If this is not the case with the "0" signal, you will have to activate the light test that meets this condition.

Wiring scheme of application 5

Single-channel connection of one sensor for each process signal. The load voltage supply is wired to terminals 2L+/2M, 3L+/3M of the digital module.

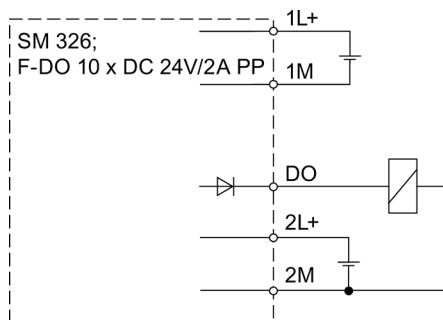

Figure 8-57 Wiring scheme of the SM 326; F-DO 10 x DC 24V/2A PP for application 5

⚠ WARNING

It is no longer possible to shut down an actuator if a cross circuit has developed between 2L+ and DO. To prevent cross circuits between 2L+ and DO, you must route the cables used to connect the actuators in a cross-circuit-proof manner (for example, as separate, sheathed cables or in separate cable ducts).

Connecting two actuators to one digital output

The fail-safe digital output is capable of switching two actuators. The following conditions have to be met:

- Wire L+ and M of the actuators to 2L+ and 2M of the module (same reference potential required).

The actuators can be wired to any one of the 10 digital outputs. The figure below shows an example of an output wiring. This circuit is compliant with SIL 3/Cat. 4/PLe.

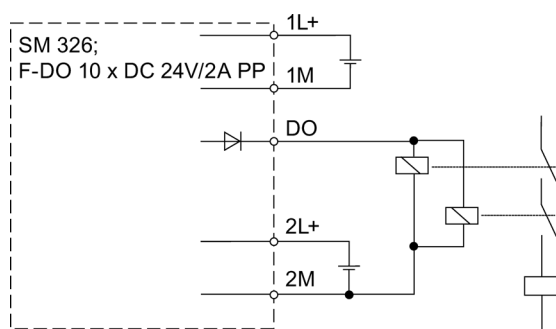

Figure 8-58 Wiring scheme 2 actuators at digital output of SM 326; F-DO 10 x DC 24V/2A PP

⚠ WARNING

It is no longer possible to shut down an actuator if a cross circuit has developed between 2L+ and DO. To prevent cross circuits between 2L+ and DO, you must route the cables used to connect the actuators in a cross-circuit-proof manner (for example, as separate, sheathed cables or in separate cable ducts).

Assignable parameters for application 5

Table 8- 23 Parameters for application 5 of SM 326; F-DO 10 x DC 24V/2A PP

Parameters	Range of values	Type	Effective range
"Parameters" tab			
Mode of operation	Safety mode	Static	Module
F_Monitoring_Time (ms)	10 ms to 10000 ms	Static	Module
Diagnostic interrupt	Activated/deactivated	Static	Module
Fail-safe value	<i>Switch to fail-safe value "0"</i> Keep last valid value	Static	Module
Maximum test period	100 / 1000 s	Static	Module
Load voltage failure diagnostics	Activated/deactivated	Static	Channel group
Activated	Activated	Static	Channel
Diagnostics: Wire break	Activated/deactivated	Static	Channel
Activated light test	Activated/deactivated	Static	Channel
Max. time for light test (ms)	0.6 ms to 5 ms	Static	Channel
Max. read-back time for dark test (ms)	0.6 ms to 400 ms	Static	Channel
Redundant switched	<i>Deactivated</i>	Static	Channel

8.7.5 Application 5.1: Wiring two outputs in parallel for dark period suppression [ID: 14338161163]

Applications

Parallel operation of two outputs for dark period suppression is possible for all applications in safety mode (application 5).

Note

In case of parameter setting with SIL3

The signal at the output has to change daily or even more frequently. If this is not the case with the "0" signal, you will have to activate the light test that meets this condition.

WARNING

Note for "Keep last valid value" parameter setting:

If a module output is 0 due to a channel/module fault and the redundant module output is 1 due to a communication fault/interruption, the process value 1 will be created.

Also note the table "Reaction of the SM 326; F-DO x DC 24V/2A PP to CPU Stop" in the chapter "Fault reactions in safety mode (Page 54)".

WARNING

Prevent short circuits to L+ at the SM 326; F-DO 10 x DC 24V/2A PP with protected routing of the signal lines, because the actuator will remain activated otherwise.

In case of a short circuit to L+ it may happen in case of redundant wiring at the output with configured redundancy operation that the associated output will not be switched off.

Wiring scheme

Interconnect two *opposite outputs* with assigned redundancy to form a single output. The parallel circuit in combination with an internal test coordination between the outputs 0 to 4 and 5 to 9 suppresses the "0" test pulse (dark period).

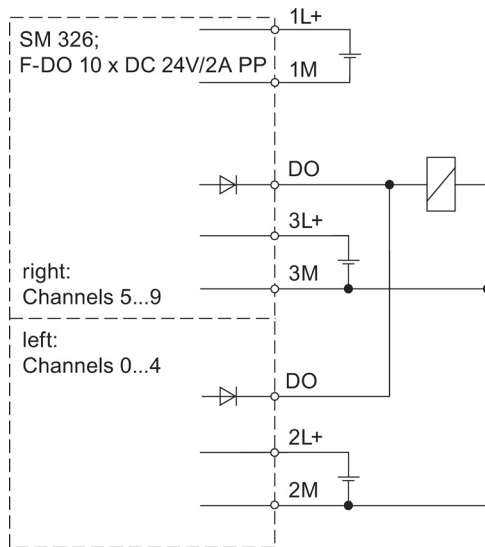

Figure 8-59 Wiring two outputs in parallel for dark period suppression of the SM 326; F-DO 10 x DC 24V/2A PP

Note

Use the same reference potential for 2M and 3M.

Note

If you are using actuators that respond too fast (< 1 ms) to "dark period" test signals, you can nonetheless use the internal test coordination by wiring two opposite outputs in parallel (with assigned redundancy). Parallel wiring suppresses the dark periods.

Parameters	Range of values	Type	Effective range
"Parameters" tab			
Mode of operation	Safety mode	static	module
F_Monitoring_Time (ms)	10 ms to 10000 ms	Static	Module
Diagnostic interrupt	Activated/deactivated	Static	Module
Fail-safe value	<i>Switch to fail-safe value</i> Keep last valid value	Static	Module
Maximum test period	100 / 1000 s	Static	Module
Load voltage failure diagnostics	Activated/deactivated	Static	Channel group
Activated	Activated/deactivated	Static	channel
Diagnostics: Wire break	Activated/deactivated	Static	Channel
Activated light test	Activated/deactivated	Static	Channel
Max. time for light test (ms)	0.6 ms to 5 ms	Static	Channel
Max. read-back time for dark test (ms)	0.6 ms to 400 ms	Static	Channel
Redundant switched	<i>Activated</i>	Static	Channel

Always set the interconnected outputs in parallel instead of setting only one output. Process signals of a redundant I/O system require four outputs with assigned redundancy.

8.7.6 Application 6: Safety mode SIL3/Cat.4/PLe with high availability (in S7 F/FH Systems only) [ID: 14338160395]

Introduction

Below are the wiring scheme and the parameter assignment of SM 326; F-DO 10 x DC 24V/2A PP for

- Application 6: Safety mode SIL3/Cat.4/PLe with high availability

Diagnostic messages, possible causes of the problem and their corrective measures are found in tables in the chapter "Diagnostic messages SM 326; F-DO 10 x DC 24V/2A PP (Page 185)".

Note

In case of parameter setting with SIL3

The signal at the output has to change daily or even more frequently. If this is not the case with the "0" signal, you will have to activate the light test that meets this condition.

WARNING

Note for "Keep last valid value" parameter setting:

If a module output is 0 due to a channel/module fault and the redundant module output is 1 due to a communication fault/interruption, the process value 1 will be created.

Also note the table "Reaction of the SM 326; F-DO x DC 24V/2A PP to CPU Stop" in the chapter "Fault reactions in safety mode (Page 54)".

WARNING

Prevent short circuits to L+ at the SM 326; F-DO 10 x DC 24V/2A PP with protected routing of the signal lines, because the actuator will remain activated otherwise.

In case of a short circuit to L+ it may happen in case of redundant wiring at the output with configured redundancy operation that the associated output will not be switched off.

Wiring scheme of application 6

Each process signal requires one actuator which is controlled redundantly by the two digital modules. The load voltage supply is wired to terminals 2L+/2M, 3L+/3M of the digital module.

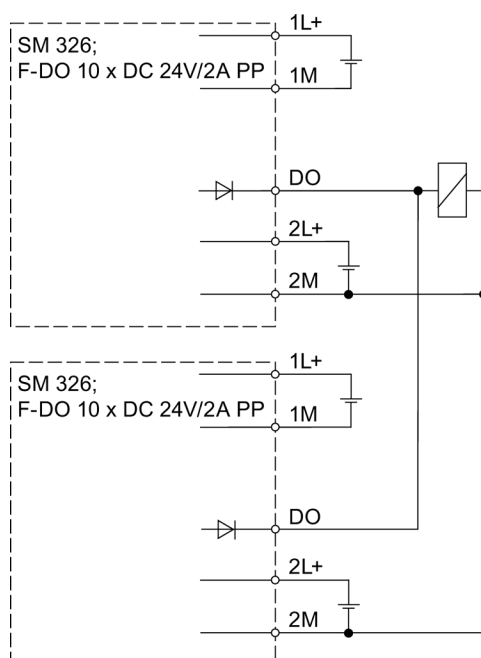

Figure 8-60 Wiring scheme of the SM 326; F-DO 10 x DC 24V/2A PP for application 6

Note

Use the same reference potential for both modules.

Assignable parameters for application 6

Table 8- 24 Parameters for application 6 of SM 326; F-DO 10 x 24V/2A PP

Parameters	Range of values	Type	Effective range
"Parameters" tab			
Mode of operation	Safety mode	Static	Module
F_Monitoring_Time (ms)	10 ms to 10000 ms	Static	Module
Diagnostic interrupt	Activated/deactivated	Static	Module
Fail-safe value	<i>Switch to fail-safe value</i> Keep last valid value	Static	Module
Maximum test period	100 / 1000 s	Static	Module
Load voltage failure diagnostics	Activated/deactivated	Static	Channel group
Activated	Activated/deactivated	Static	Channel
Diagnostics: Wire break	Activated/deactivated	Static	Channel
Activated light test	Activated/deactivated	Static	Channel
Max. time for light test (ms)	0.6 ms to 5 ms	Static	Channel
Max. read-back time for dark test (ms)	0.6 ms to 400 ms	Static	Channel
Redundant switched	<i>Activated</i>	Static	Channel

8.7.7 Diagnostic messages SM 326; F-DO 10 x DC 24V/2A PP [ID: 14518644107]

Diagnostics using the LED display

The F-SM indicates faults by means of its SF LED (group fault LED). The SF LED is activated when the F-SM generates a diagnostic message.

The SF LED flashes as long as a cleared fault has not been acknowledged. It goes dark when all faults have been eliminated and acknowledged.

The SF LED flashes until you acknowledge passivation following a module fault.

Possible diagnostic messages

The following table provides an overview of the diagnostic messages for SM 326; F-DO 10 x DC 24V/2A PP.

Diagnostic messages are assigned either to a channel or to the entire module. Some diagnostic messages occur only in certain applications.

Table 8- 25 Diagnostic messages of SM 326; F-DO 10 x DC 24V/2A PP

Diagnostic message	Signaled in the application	Effective range of diagnostics	Assignable
Wire break	5, 6	Channel	Yes
Short-circuit of output to M, or defective output driver			No
Short circuit of output to L+, or defective output driver	5	Module	
Module parameters not assigned	5, 6	Module	
Incorrect module parameters			
Communication error			
Internal supply voltage of the module failed			
Time monitoring activated (watchdog)			
EPROM fault; RAM fault			
Internal error in read circuit/test circuit, or defective sensor supply			
Processor failure			
Parameter assignment error (with specification of a consecutive number)			
No external auxiliary voltage			
External load voltage missing			
Defective main switch			
Defective output driver			
Overtemperature at output driver			
Defective load voltage or load voltage not connected			
CRC signature error	5, 6	Module	
Timeout of safety message frame monitoring			
Switching frequency too high			Channel

Causes of the problem and corrective measures

The table below shows possible causes of the problem and appropriate corrective measures for the individual diagnostic messages of SM 326, F-DO 10 x DC 24V/2A PP.

Table 8- 26 Diagnostic messages and associated corrective measures for SM 326; F-DO 10 x DC 24V/2A PP

Diagnostic message	Error detection	Possible causes of the problem	Corrective measures
Wire break	Only if the output = 1 or during light period test	Wire break between the module and actuator	Restore the cable connection
		Channel not connected (open)	Disable the "Group Diagnostics" for the channel in the parameter settings.
		Short-circuit to L+ at the output	Eliminate the short-circuit
		Short-circuit between channels which carry different signals	Eliminate the short-circuit
Short-circuit of output to M, or defective output driver	Only if the output = 1 or during light period test	Output overload	Remove the overload within 100 hours after the fault has occurred.
		Short-circuit to M at the output	Remove the short circuit within 100 hours after the fault has occurred.
		Undervoltage at load voltage supply	Check the load voltage supply
		Defective output driver	Replace the module
Short circuit of output to L+, or defective output driver	For non-redundant operation	Short-circuit to L+ at the output	Remove the short circuit within 100 hours after the fault has occurred. Module reset required (cycle power supply off/on)
		Short-circuit between channels which carry different signals	Remove the short circuit within 100 hours after the fault has occurred. Module reset required (cycle power supply off/on)
	general	Defective output driver	Replace the module
Module parameters not assigned	General	No parameters transferred to module	Assign new module parameters
Incorrect module parameters	general	Faulty parameters transferred to module	Assign new module parameters
Internal supply voltage of the module failed	general	Internal fault at supply voltage 1L+	Replace the module

Diagnostic message	Error detection	Possible causes of the problem	Corrective measures
Time monitoring activated (watchdog)	general	Overload due to diagnostics request (SFCs)	Reduce the number of diagnostics requests
		Electromagnetic interference has exceeded limits	Eliminate the interference
		Defective module	Replace the module
Communication error	general	Error in communication between the CPU and the module, for example, due to defective PROFIBUS connection or electromagnetic interference in excess of limits.	Check the PROFIBUS connection Eliminate the interference
		Timeout of data frame monitoring	Check the monitoring time parameters
		CRC signature error, for example, due to electromagnetic interference in excess of limits.	Eliminate the interference
		CPU is in STOP	Read the diagnostics buffer
EPROM error RAM error	general	Electromagnetic interference has exceeded limits	Eliminate the interference and cycle power supply OFF/ON
		Defective module	Replace the module
Internal error in read / test sequence	General	Defective module	Replace the module
Processor failure	general	Electromagnetic interference has exceeded limits	Eliminate the faults, and then remove and insert the module
		Defective module	Replace the module
		Switching rate exceeded	Reduce switching rate
Parameter assignment error (with specification of a consecutive number)	general	Error in dynamic parameter reassignment	Check the parameter assignment in the user program. Contact SIMATIC Customer Support if necessary
No external auxiliary voltage	general	Supply voltage 1L+ of module missing	Connect 1L+
External load voltage missing	general	Supply voltage 1L+ of module missing	Feed in voltage supply
Defective main switch	general	Defective module	Replace the module
Defective output driver	general	Defective module	Replace the module
Overtemperature at output driver	general	Output overload	Eliminate the cause of overload
		Internal fault at output driver	Replace the module

Diagnostic message	Error detection	Possible causes of the problem	Corrective measures
Defective load voltage or load voltage not connected	general	Load voltage 2L+, 3L not connected	Connect 2L+ and 3L+
		Load voltage external error	Replace the module
CRC signature error	general	CRC signature error during communication between the CPU and the module has occurred, for example, due to electromagnetic interference in excess, faults during sign-of-life monitoring error, in case of voltage drop or standard program accesses F-SM.	Eliminate the interference
Timeout of safety message frame monitoring	general	Assigned monitoring time exceeded	Check the monitoring time parameters
		Startup of the fail-safe signal module	—
Message frame error	general	Sign-of-life and/or CRC signature entered in the data message frame	Check the sign-of-life and CRC signature entries in the data message frame for "0" value
Switching frequency too high	general	Switching frequency too high	Reduce the switching frequency

Note

Note that an inductive load connected to the DO channels can induce voltages due to interference of a strong, magnetic field. This situation can result in the diagnostic message short circuit.

Remedy:

- Create a spatial separation of the inductive loads and shield the magnetic field.
- Configure the read-back time of the dark test with 50 ms or greater.

Note

In case of a wire break at an actuator with redundant control by two modules, both modules will report a wire break. The wire break diagnostic will come at a later time.

Note

If the F-SM detects an external P-short circuit on a channel, it will turn off all channels that route "1" signals and are not configured redundantly.

The channels that are actually affected will be determined afterwards; channels without active fault can be reintegrated at this time.

8.7.8 Technical data - SM 326; F-DO 10 x DC 24V/2A PP [ID: 14338161931]

Overview

Technical specifications	
Dimensions and weight	
Dimensions W x H x D (mm)	40 x 125 x 120
Weight	ca. 330 g
Module-specific specifications	
Number of outputs	10
Assigned address area	
• In the I/O input area	6 bytes
• In the I/O output area	8 bytes
Cable length	
• Unshielded	Max. 600 m
• Shielded	Max. 1000 m (see note at end of table)
Front connectors	40-pin
Maximum achievable Safety Integrity Level in safety mode	
• According to IEC 61508:2000	SIL 3
• According to ISO 13849-1:2006 or EN ISO 13849-1:2008	Cat. 4/PLe
Fail-safe performance characteristics	
• low demand mode (average probability of failure on demand)	< 1.00E-05
• high demand / continuous mode (probability of a dangerous failure per hour)	< 1.00E-09
Proof-test interval	20 years
Voltages, Currents, Potentials	
Rated supply voltage of the electronics 1L+	24 V DC
• Reverse polarity protection	Yes
Rated load voltage 2L+/3L+	24 V DC
• Reverse polarity protection	No
Aggregate current of outputs (per group)	
• Horizontal installation Up to 40 °C Up to 50 °C Up to 60 °C	Max. 10 A Max. 7 A Max. 6 A
• Vertical installation Up to 40 °C	Max. 5 A

Technical specifications	
Electrical isolation	
• Between channels and backplane bus	Yes
• Between channels and the power supply of the electronics	Yes
• Between channels In groups of	Yes 5
Permitted potential difference Between different circuits	75 V DC 60 V AC
Insulation test voltage	370 V AC for 1 min.
Current consumption	
• From backplane bus	Max. 100 mA
• From supply voltage 1L+	Max. 100 mA
• From load voltage 2L+/ 3L+ (no-load)	Max. 100 mA
Power loss of the module	6 W, typical
Status, Interrupts, Diagnostics	
Status display	1 green LED 1 red LED
Interrupts	
Diagnostic interrupt	Configurable
Diagnostics functions	Configurable
Group fault display	Red LED (SF)
Fail-safe mode display	Green LED (SAFE)
Diagnostic information can be read out	Possible
Fail-safe values	Switch to / Keep last valid value
Actuator selection data	
Output voltage	
• For "1" signal	Minimum L+ (-1.0 V)
Output current	
• For "1" signal – Rated value – Approved range	2 A 7 mA to 2.4 A
• For "0" signal (residual current)	Max. 0.5 mA
Load resistance range	
• Up to 40 °C	12 Ω to 3.4 kΩ
• Up to 60 °C	12 Ω to 3.4 kΩ
Lamp load	Max. 5 W
Parallel switching of 2 outputs	
• For redundant load control	With assigned redundancy
• For power increase	Not possible

Technical specifications	
Control of a digital input	Possible
Switching frequency	
• With resistive load	Max. 25 Hz symmetrical
• with inductive load (see section "Switching capacitive and inductive loads (Page 349)")	Max. 25 Hz symmetrical
• With inductive load in accordance with IEC 60947-5-1, DC 13	Max. 0.5 Hz symmetrical
• With lamp load	Max. 10 Hz symmetrical
Internal limit of the inductive shutdown voltage	type L+ (-33 V)
Short-circuit protection of output	Yes, electronic
• Response threshold	2.6 to 4.5 A
• Response threshold of redundant interconnection	2.6 to 9 A
Actuator timing requirements	Actuator must not respond if: <ul style="list-style-type: none"> • Dark period < 0.6 ms • Light period < 0.6 ms (refer to section "Sensor and Actuator Requirements for F-SMs in Safety Mode (Page 50)")
Time, Frequency	
Internal preparation time for	
• Safety mode	Max. 8 ms
• Redundant safety mode	Max. 8 ms
Acknowledgment time	
• In safety mode	Max. 10 ms

Note

To reach the maximum cable length, it may be necessary to increase the settings for maximum light test time or maximum read-back time dark test.

We also recommend a more detailed consideration of the boundary conditions, such as EMC, cables used, cable guide, etc.

Analog modules

9.1 Introduction [ID: 431745931]

In this chapter

Two fail-safe, redundancy-capable analog modules of the S7-300 module line are available for connecting analog sensors/encoders:

- the SM 336; AI 6 x 13Bit,
- the SM 336; F-AI 6 x 0/4 ... 20 mA HART.

Information on fail-safe analog modules provided in this chapter:

- Properties
- Module view and block diagram
- Applications, including the wiring diagrams and parameter settings
- Diagnostic messages, including corrective measures
- the HART messages (SM 336; F-AI 6 x 0/4 ... 20 mA HART only) and
- Technical data

 WARNING
--

The fail-safe performance characteristics in the technical data apply to a module-dependent proof-test interval and a mean time to repair of 100 hours.

9.2 SM 336; AI 6 x 13 Bit

9.2.1 Analog value representation [ID: 431748619]

Measured value ranges

Table 9- 1 Measured value ranges of SM 336; AI 6 x 13Bit

Measuring range				Unit		Range
0 mA to 20 mA	4 mA to 20 mA	0 V to 10 V	as percentage of the nominal range	Decimal	Hexadecimal	
Standard mode	Safety mode	Standard mode				Mode of operation
> 23.515 mA	> 22.814 mA	> 11.7593 V	> 117,589	32767	7FFF _H *	Overflow
23.515 mA	22.814 mA	11.7589 V	117,589	32511	7EFF _H	Overrange
.	
20.007 mA	20.007 mA	> 10.0004 V	100,004	27649	6C01 _H	
20 mA	20 mA	10 V	100	27648	6C00 _H	Nominal range
.	
2.89 µA	4 mA + 2.315 µA	1.45 V	0,014	4	4 _H	
0 mA	4.00 mA	0 V	0	0	0 _H	
-0.0007 mA	3.9995 mA	-0.36 mV	-0,0036	-1	FFFF _H	Underrange
.	
-3.518 mA	1.185512 mA	-1.759 V	-17,593	-4864	ED00 _H	
< -3.518 mA	< 1.185 mA (see below)	< -1.759 V	< -17,593	-32768	8000 _H *	Underflow
<p>* In <i>S7 F/FH Systems</i> a fail-safe value is output for this value in the safety program when overflow or underflow is detected.</p> <p>In <i>S7 Distributed Safety</i>, the fail-safe value 0 is provided in the PII for the safety program in place of 7FFF_H (for overflow) and 8000_H (for underflow).</p>						

Units in decimal/hexadecimal format can only assume values of a multiple of four.

Wire-break check and underflow check in the range 4 to 20 mA

In the range 4 to 20 mA, a check is made to determine whether wire-break check is assigned.

- If wire-break check is assigned, an underflow check is not performed. In *S7 F/FH Systems*, wire break is reported with 7FFF_H if the current is < 3.6 mA. In *S7 Distributed Safety*, the fail-safe value 0 is provided in the PII for the safety program in place of 7FFF_H.
- In *S7 F/FH Systems*, if wire-break check is not configured, underflow is reported with 8000_H if the current is < 1.18 mA. In *S7 Distributed Safety*, the fail-safe value 0 is provided in the PII for the safety program in place of 8000_H (for underflow).

Measured value resolution

The SM 336; AI 6 x 13Bit has a 13-bit resolution. That is, the last two bits are set to zero. The values returned must be multiples of four. 1 digit (13-bit measuring range) corresponds to 4 digits Simatic.

Table 9- 2 Representation of the bit pattern

Bit number	15	14	13	12	11	10	9	8	7	6	5	4	3	2	1	0
Bit significance	Sign	2 ¹⁴	2 ¹³	2 ¹²	2 ¹¹	2 ¹⁰	2 ⁹	2 ⁸	2 ⁷	2 ⁶	2 ⁵	2 ⁴	2 ³	2 ²	2 ¹	2 ⁰
Example	0	1	0	0	1	1	0	0	1	1	1	1	1	1	0	0

Table 9- 3 Resolution

Measuring range	% of nominal range	Resolution
0 mA to 20 mA	0,014	2.89 µA
4 mA to 20 mA	0,014	2.32 µA
0 V to 10 V	0,014	1.45 mV

 WARNING
Only the measuring range 4 to 20 mA is allowed when operating in safety mode.

9.2.2 Properties, front view, wiring diagram and block diagram [ID: 431719051]

Order number

6ES7336-1HE00-0AB0

Properties

SM 336; AI 6 x 13Bit has the following properties:

- 6 analog inputs with electrical isolation between channels and the backplane bus
- Input ranges:
 - 0 to 20 mA or 4 to 20 mA, 0 to 10 V in standard mode
 - 4 to 20 mA in safety mode
- Short circuit-proof power supply of 2- or 4-wire transducers by the module
- External sensor supply possible
- Group fault display (SF)
- Safety mode display (SAFE)
- Sensor supply display (Vs)
- Programmable diagnostics functions
- Programmable diagnostic interrupt
- Supports operation in standard and safety mode

Use of inputs

You can use the inputs as follows:

- In standard mode
 - All 6 channels for current measurement 0 to 20 mA or 4 to 20 mA, or
 - Up to 4 channels for voltage measurement 0 to 10 V and the remaining 2 channels for current measurement.
 - Other combinations of current and voltage measurements; make allowances for voltage measurement restrictions defined earlier.
- In safety mode
 - All 6 channels for current measurements 4 to 20 mA.

Address assignment

The following figure shows the assignment of channels to addresses.

Addressing of the inputs in the user program:

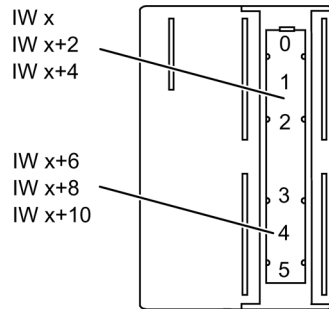

x = Module start address

Figure 9-1 Address assignment for SM 336; AI 6 x 13Bit

Front view

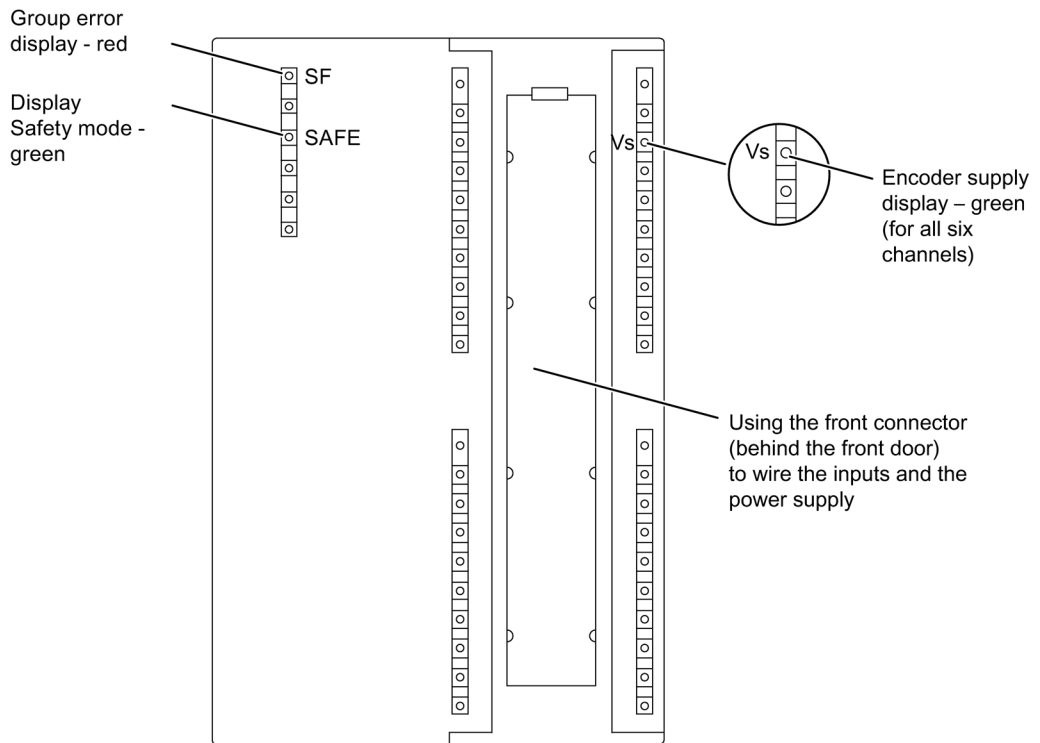
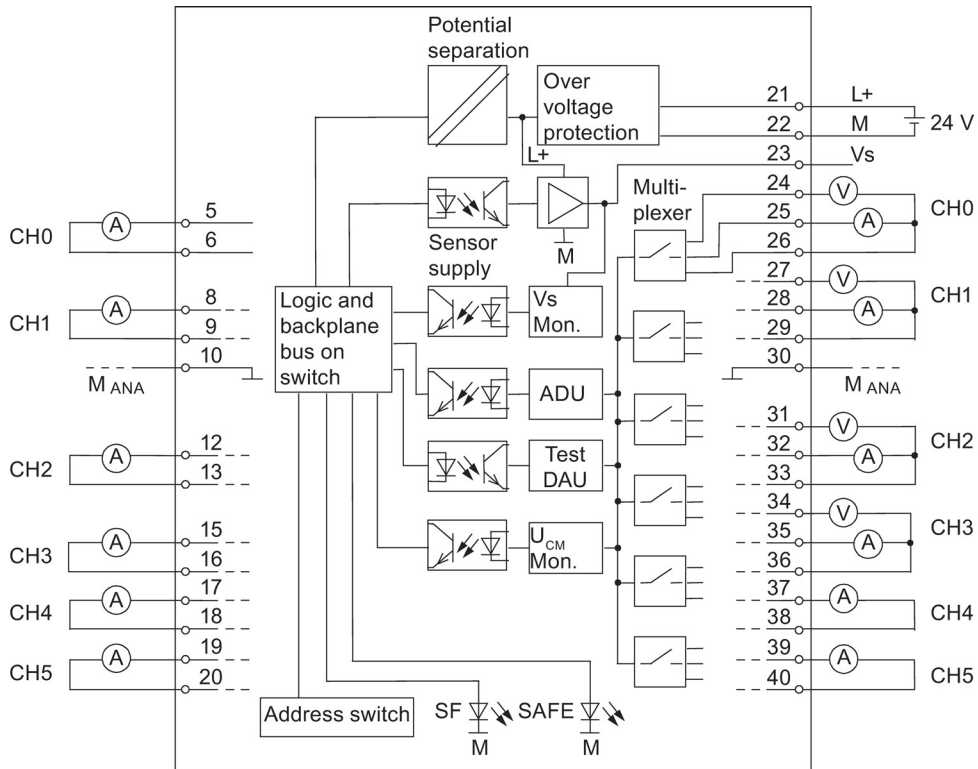

Figure 9-2 Front view of SM 336; AI 6 x 13Bit

Wiring and block diagram

The following figure shows the the wiring and block diagram of SM 336; AI 6 x 13Bit. The internal circuitry of the connections on the left side of the figure correspond to the circuitry of the connections on the right. The wiring and block diagrams of analog sensors for the different applications are shown in the next chapters.



A Current measurement
 V Voltage measurement

Figure 9-3 Wiring and block diagram of SM 336; AI 6 x 13Bit and internal sensor supply

Channel numbers

The channel numbers are used to uniquely identify the inputs and to assign channel-specific diagnostic messages.

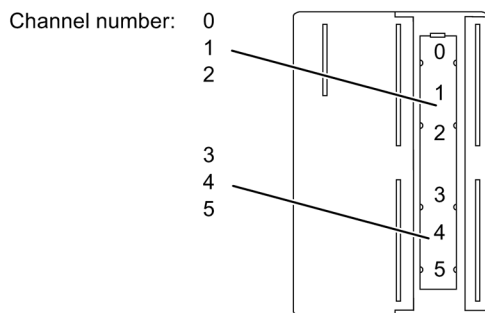

Figure 9-4 Channel numbers for SM 336; AI 6 x 13Bit

Sensor supply

WARNING

Voltage dips of the power supply are not buffered by the module and, thus, affect the sensor supply.

This can cause the measured value to be false.

You can avoid voltage dips by using a voltage supply according to the NAMUR recommendation (see Chapter " Safe Functional Extra-Low Voltage for Fail-Safe Signal Modules (Page 46) "). Alternatively, use a transducer with an appropriate battery backup or diagnostics.

External sensor supply

The figures below shows how you can supply power to the sensors by means of an external sensor supply (for example, from another module: 1L+).

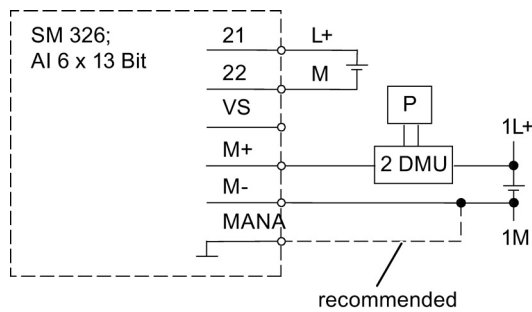

Figure 9-5 External encoder supply, 2-wire transducer for SM 336; AI 6 x 13Bit

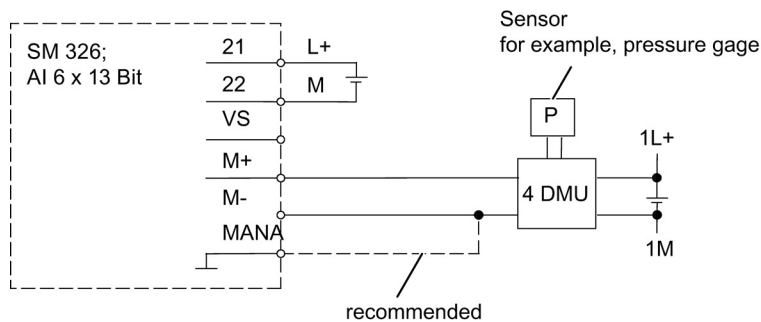

Figure 9-6 External encoder supply, 4-wire transducer for SM 336; AI 6 x 13Bit

 **WARNING**

The **stability** of the external sensor supply must conform to the desired safety requirement class SIL 2, 3. To ensure that the sensor functions problem-free, we recommend one of the following options:

- Use of a **redundant** external sensor supply
or
- **Monitoring** of the external sensor supply for undervoltage/overvoltage, including shutdown of the sensor supply when a fault is detected (single-channel for SIL 2; two-channel for SIL 3)

Recommendation: Internal sensor supply

You are strongly advised to use the short circuit-proof internal sensor supply of the module. This internal sensor supply is monitored and its status is indicated at the Vs LED (see Figure *Front view of SM 336; AI 6 x 13 Bit*).

Isolated transducers

The isolated transducers are not bonded to local earth potential. These transducers can be operated with floating potential. Local conditions or interference may cause potential differences U_{CM} (static or dynamic) between the measuring lines M- of the input channels and the reference point of the measuring circuit M_{ANA} .

It is advisable to wire M- to M_{ANA} to prevent common mode voltages in excess of the permitted value for U_{CM} when operating the equipment in areas subject to heavy EMC interference.

Non-isolated transducers

The non-isolated transducers are bonded to local earth potential. Always interconnect M_{ANA} with earth potential. Local conditions or interference may cause potential differences U_{CM} (static or dynamic) between the locally distributed measuring points.

If common mode voltage exceeds the permissible value for U_{CM} , you must provide for equipotential bonding conductors between the measuring points.

Improving current measuring precision at channels 0 through 3 of the analog input module

It is advisable to interconnect unused voltage inputs with the corresponding current input when using channels 0 to 3 of SM 336; AI 6 x 13Bit for current measurements. See the figure below. This measure improves precision by approx. 0.2%.

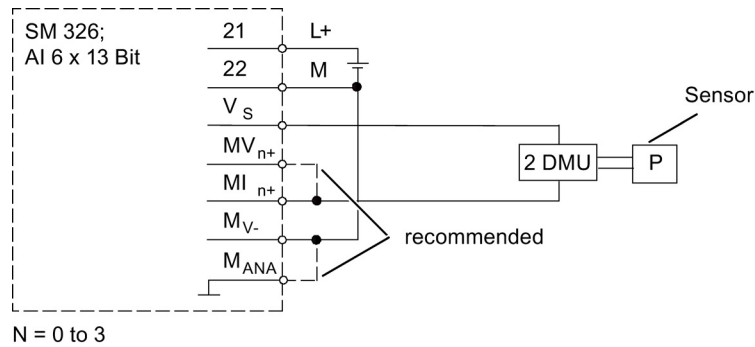

Figure 9-7 Improving current measuring precision at channels 0 through 3 using 2 DMU

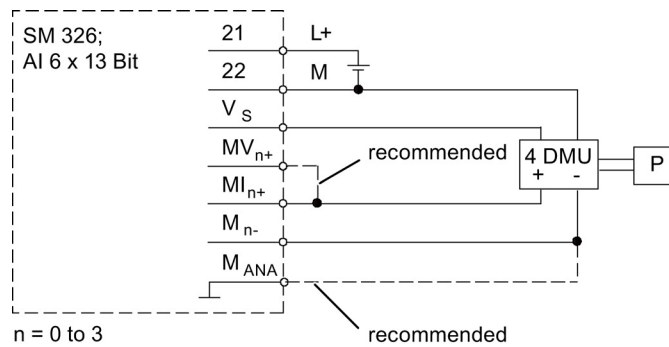

Figure 9-8 Improving current measuring precision at channels 0 through 3 using 4 DMU

9.2.3 Applications of SM 336; AI 6 x 13 Bit [ID: 56062553099]

Selecting the application

The figure below helps you to select an application based on availability and fail-safe operation requirements. The next pages provide information on the module wiring and parameter settings in *STEP 7*.

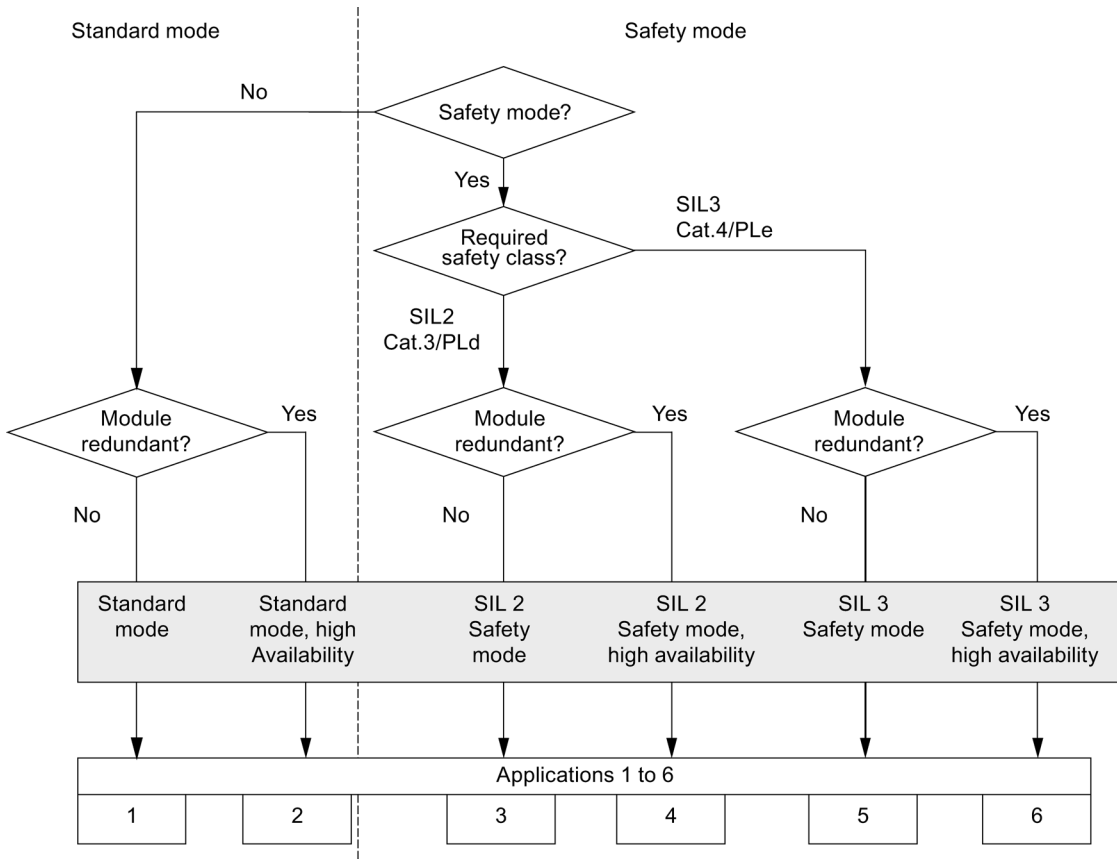

Figure 9-9 Application Selection - SM 336; AI 6 x 13 Bit

	WARNING
<p>The maximum Safety Integrity Level is determined by the sensor quality and the length of the proof-test interval according to the IEC 61508:2000 standard. If the sensor quality does not meet Safety Integrity Level requirements, always wire redundant sensors and connect them via two channels.</p>	

Wiring schemes

Three wiring schemes are available for each application, depending on the type of measurement.

Table 9- 4 Wiring scheme of SM 336; AI 6 x 13 Bit

Wiring scheme	Measurement type	Range	Channels	Abbreviation in HW Config
A	Current measurement with 2-wire transducer	4 to 20 mA	0 to 5	2DMU
B	Current measurement with 4-wire transducer	4 to 20 mA 0 to 20 mA*	0 to 5	4DMU
C	Voltage measurement*	0 V to 10 V	0 to 3	V

* Current measurement 0 to 20 mA and voltage measurement are only supported in standard mode.

Note

In the wiring schemes below, the connections to the reference point of the measuring circuit M_{ANA} are represented by a dashed line. This means these connections are recommended options (see section "Properties, front view, wiring diagram and block diagram (Page 196)").

A dashed connection between two or four sensors indicates that these sensors measure the same process variable.

9.2.4 Application 1 : Standard Mode [ID: 431724427]

Introduction

Below are the wiring schemes and the parameter assignment of SM 336; AI 6 x 13Bit for

- Application 1: Standard mode

Diagnostic messages, possible causes of the problem and their corrective measures are found in tables *Diagnostic messages of SM 336; AI 6 x 13Bit* and *Diagnostic messages and associated corrective measures for SM 336; AI 6 x 13Bit* in chapter "Diagnostic Messages for SM 336; AI 6 x 13 Bit (Page 232)".

Wiring scheme A, current measurement 4 to 20 mA with 2-wire transducer for application 1

You can interconnect six process signals with an analog module. Sensor supply V_s is provided by the analog module for 6 channels. The sensors can also be connected to an external sensor supply (see figure *External sensor supply, 2-wire transducer for SM 336; AI 6 x 13Bit* in chapter "Properties, front view, wiring diagram and block diagram (Page 196)").

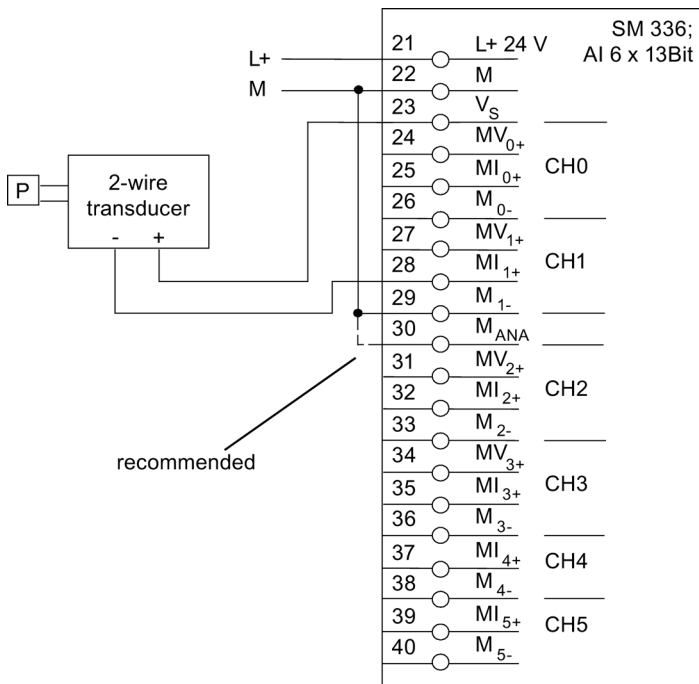

Figure 9-10 Current measurement 4 to 20 mA, 2-wire transducer for application 1 with SM 336; AI 6 x 13Bit

Wiring scheme B, current measurement 0 to 20 mA with 4-wire transducer for application 1

You can interconnect six process signals with an analog module. Sensor supply V_S is provided by the analog module for 6 channels. The sensors can also be connected to an external sensor supply (see figure *External sensor supply, 4-wire transducer for SM 336; AI 6 x 13Bit* in chapter "Properties, front view, wiring diagram and block diagram (Page 196)").

The wire-break check function reduces the measuring range to 4 to 20 mA.

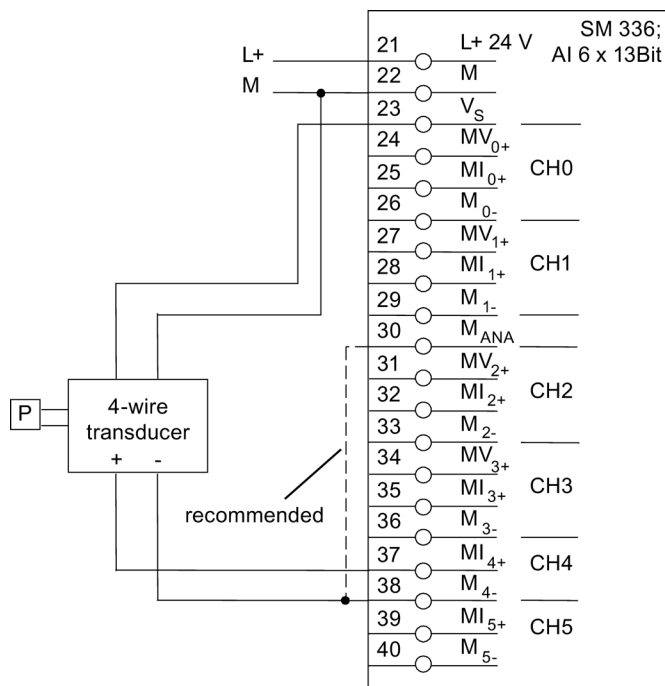

Figure 9-11 Current measurement 4 to 20 mA, 4-wire transducer for application 1 with SM 336; AI 6 x 13Bit

Wiring scheme C, voltage measurement 0 V to 10 V, for application 1

You can interconnect four process signals with an analog module. Sensor supply V_s is provided by the analog module for 4 channels. The sensors can also be connected to an external sensor supply (see figure *External sensor supply, 4-wire transducer for SM 336; AI 6 x 13Bit* in chapter "Properties, front view, wiring diagram and block diagram (Page 196)").

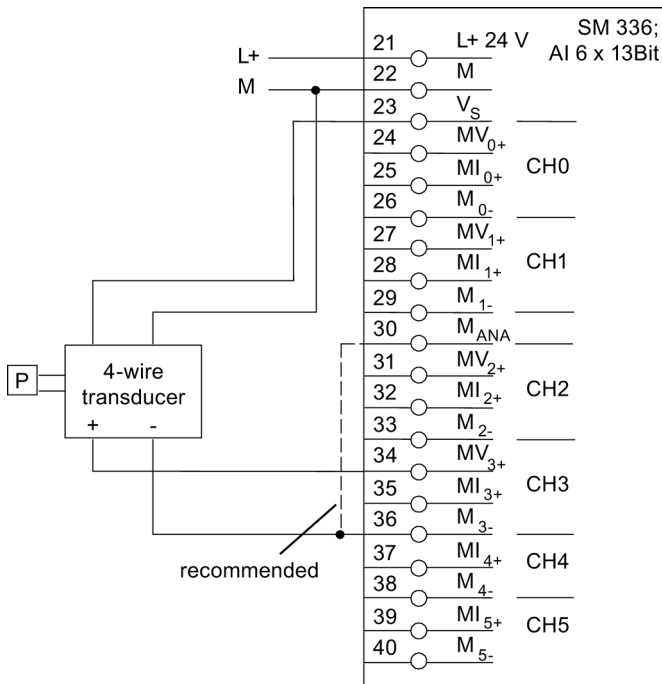

Figure 9-12 Voltage measurement 0 to 10 V for application 1 with SM 336; AI 6 x 13Bit

Assignable parameters for application 1

Table 9- 5 Parameters for application 1 of SM 336; AI 6 x 13Bit

Parameters	Range of values in standard mode	Type	Effective range
"Inputs 1" tab			
Enable diagnostic interrupt	Activated/deactivated	Static	Module
Interference frequency	50 Hz/60 Hz	Static	Module
Group diagnostics	Activated/deactivated	Static	Channel
Wire-break check (only for 4 to 20 mA)	Activated/deactivated	Static	Channel
Measurement type	<ul style="list-style-type: none"> • Deactivated • 4DMU • 2DMU • V 	Static	Channel
Measuring range	<ul style="list-style-type: none"> • 4 to 20 mA • 0 to 20 mA • 0 to 10 V 	static	channel
"Inputs 2" tab			
Safety mode	No (standard mode)	Static	Module
Monitoring time	—	Static	Module
"Redundancy" tab			
Redundancy	none	Static	Module

9.2.5 Application 2: standard mode with high availability [ID: 431727115]

Introduction

Below are the wiring schemes and the parameter assignment of SM 336; AI 6 x 13Bit for

- Application 2: standard mode with high availability

Diagnostic messages, possible causes of the problem and their corrective measures are found in tables *Diagnostic messages of SM 336; AI 6 x 13Bit* and *Diagnostic messages and associated corrective measures for SM 336; AI 6 x 13Bit* in chapter "Diagnostic Messages for SM 336; AI 6 x 13 Bit (Page 232)".

Wiring scheme A, current measurement 4 to 20 mA with 2-wire transducer for application 2

You can interconnect six process signals with two redundant analog modules. Two sensors are connected via one channel to the two analog modules for each process signal. Sensor supply V_S is provided by the analog module for 6 channels. The sensors can also be connected to an external sensor supply (see figure *External sensor supply, 2-wire transducer for SM 336; AI 6 x 13Bit* in chapter "Properties, front view, wiring diagram and block diagram (Page 196)").

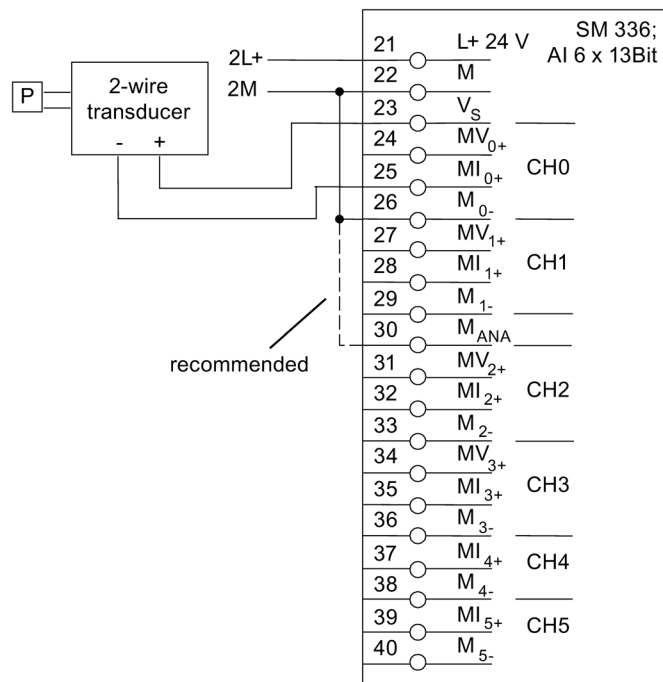
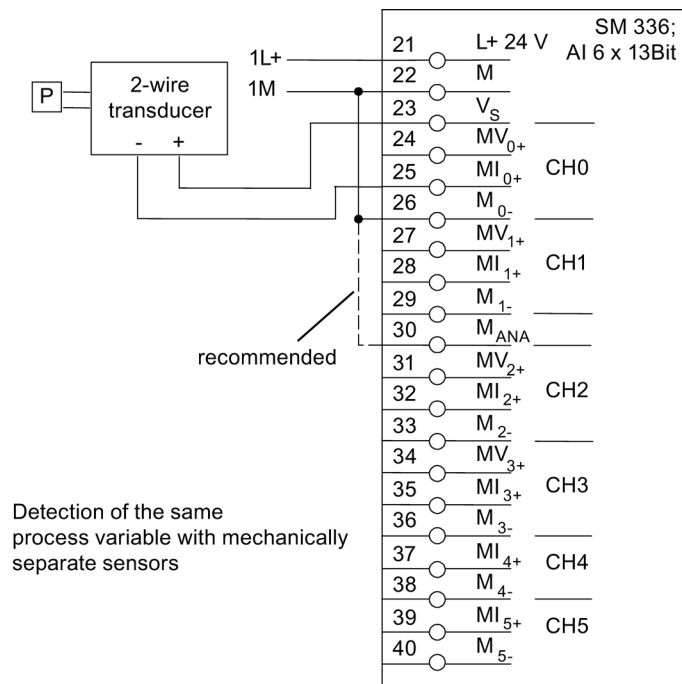

Wiring scheme B, current measurement 0 to 20 mA with 4-wire transducer for application 2

You can interconnect six process signals with two redundant analog modules. Two sensors are connected via one channel to the two analog modules for each process signal. Sensor supply V_s is provided by the analog module for 6 channels. The sensors can also be connected to an external sensor supply (see figure *External sensor supply, 4-wire transducer for SM 336; AI 6 x 13Bit* in chapter "Properties, front view, wiring diagram and block diagram (Page 196)"). The wire-break check function reduces the measuring range to 4 to 20 mA.

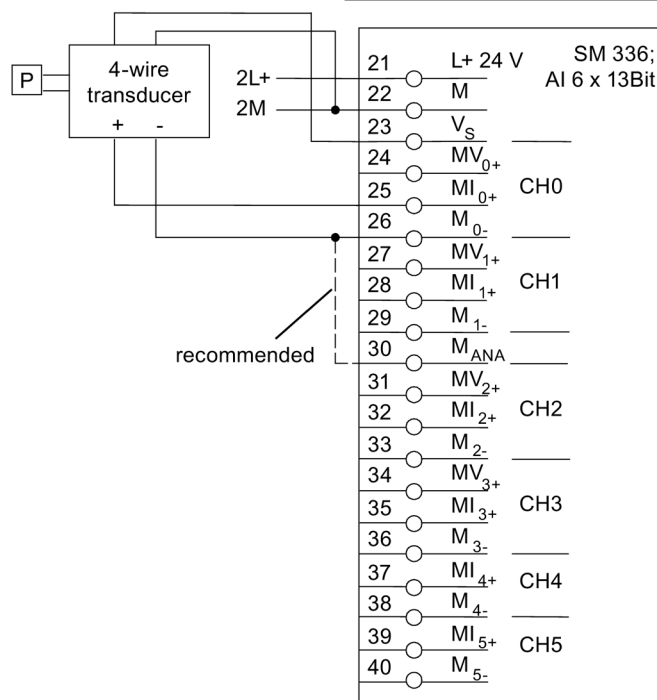
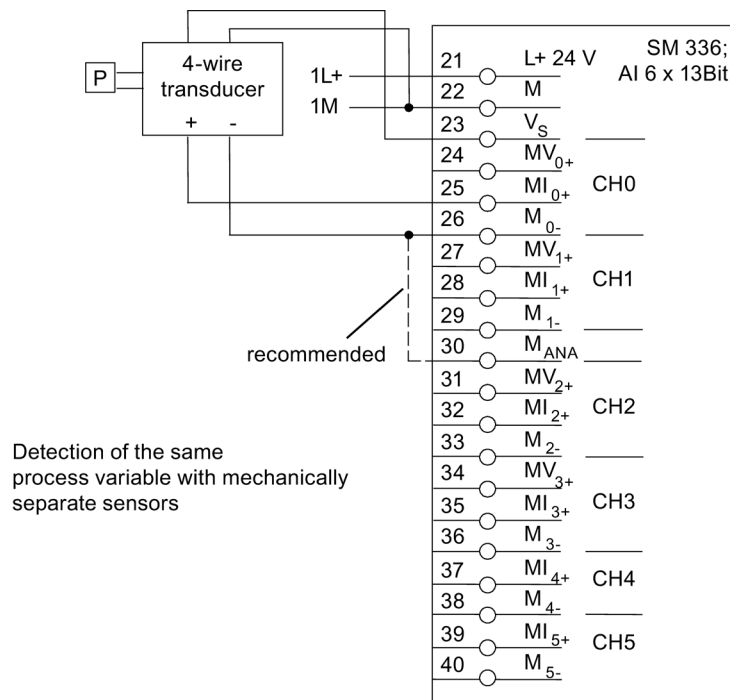

Wiring scheme C, current measurement 0 to 10 V with 4-wire transducer for application 2

You can interconnect four process signals with two redundant analog modules. Two sensors are connected via one channel to the two analog modules for each process signal. Sensor supply V_s is provided by the analog module for 6 channels. The sensors can also be connected to an external sensor supply (see figure *External sensor supply, 2-wire transducer for SM 336; AI 6 x 13Bit* in chapter "Properties, front view, wiring diagram and block diagram (Page 196)").

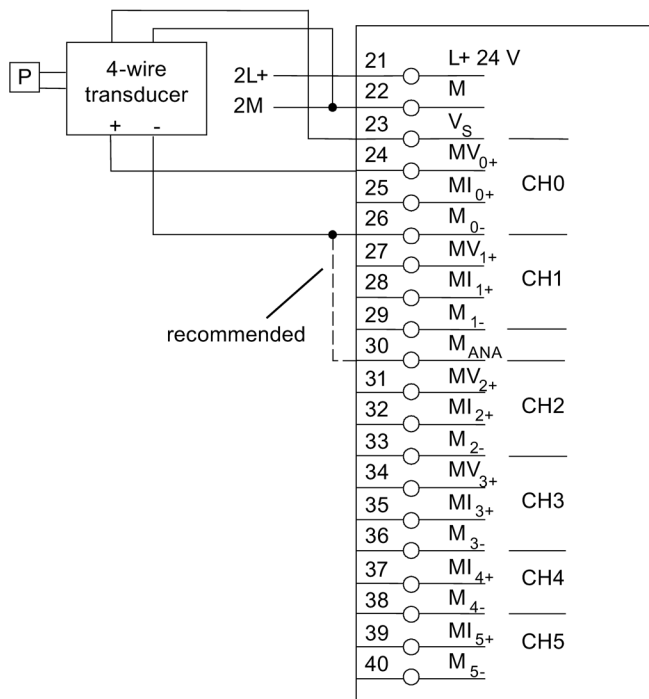
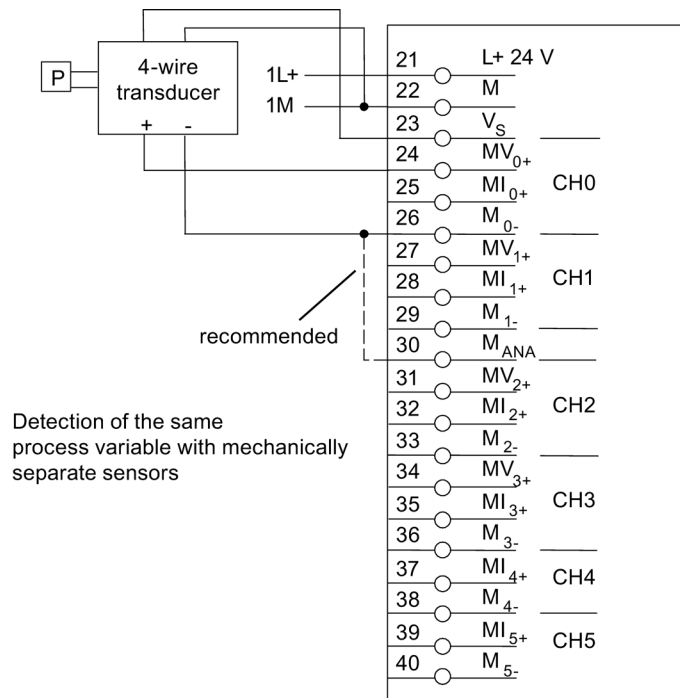

Assignable parameters for application 2

Table 9- 6 Parameters for application 2 of SM 336; AI 6 x 13Bit

Parameters	Range of values in standard mode	Type	Effective range
"Inputs 1" tab			
Enable diagnostic interrupt	Yes/no	Static	Module
Interference frequency	50 Hz/60 Hz	Static	Module
Group diagnostics	Yes/no	Static	Channel
Wire-break check (only for 4 to 20 mA)	Yes/no	Static	Channel
Measurement type	<ul style="list-style-type: none"> • Deactivated • 4DMU • 2DMU • V 	Static	Channel
Measuring range	<ul style="list-style-type: none"> • 4 to 20 mA • 0 to 20 mA • 0 to 10 V 	static	channel
"Inputs 2" tab			
Safety mode	No (standard mode)	static	module
Monitoring time	—	static	module
"Redundancy" tab*			
Redundancy	2 modules	static	module
Redundant module	Selection of an existing additional module of the same type	static	Redundant module pair
* The two analog values returned in a redundant configuration operating in standard mode must be evaluated in the default user program.			

9.2.6 Application 3: Safety mode SIL2/Cat.3/PLd [ID: 431729803]

Introduction

Below are the wiring schemes and the parameter assignment of SM 336; AI 6 x 13Bit for

- Application 3: Safety Mode SIL2/Cat.3/PLd.

Diagnostic messages, possible causes of the problem and their corrective measures are found in tables *Diagnostic messages of SM 336; AI 6 x 13Bit* and *Diagnostic messages and associated corrective measures for SM 336; AI 6 x 13 Bit* in chapter "Diagnostic Messages for SM 336; AI 6 x 13 Bit (Page 232)".

Wiring scheme A, current measurement 4 to 20 mA with 2-wire transducer for application 3

You can interconnect six process signals with an analog module. Sensor supply V_S is provided by the analog module for 6 channels. The sensors can also be connected to an external sensor supply (see figure *External sensor supply, 2-wire transducer for SM 336; AI 6 x 13Bit* in chapter "Properties, front view, wiring diagram and block diagram (Page 196)").

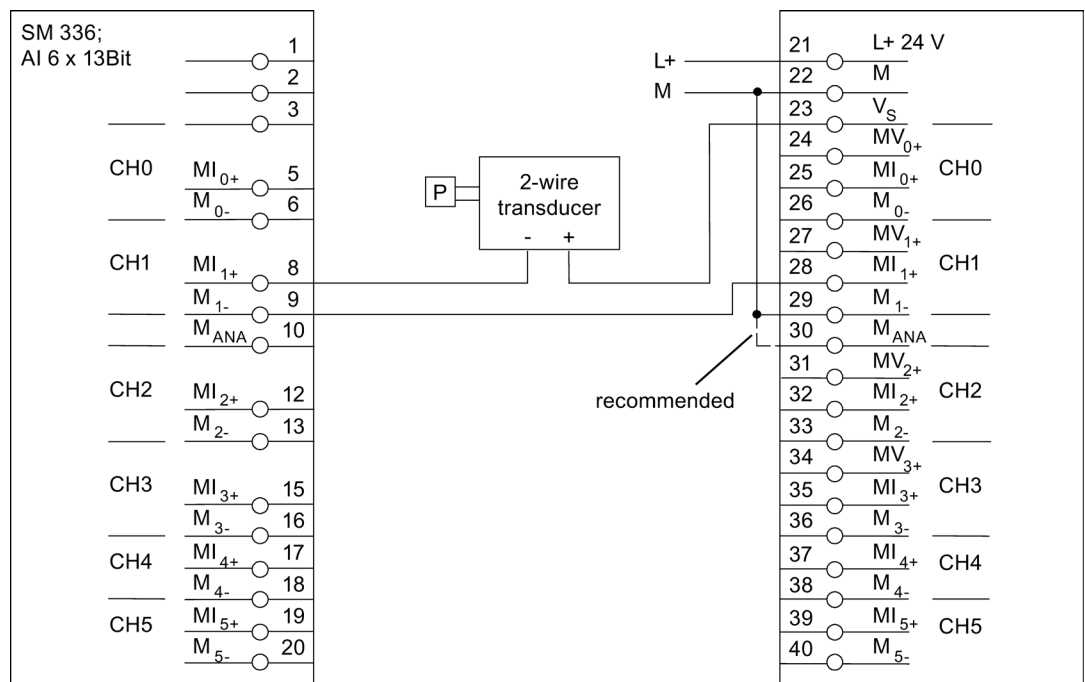



Figure 9-13 Current measurement 4 to 20 mA, 2-wire transducer for application 3 with SM 336; AI 6 x 13Bit

 WARNING
To achieve SIL3/Cat.4/PLe using this wiring, you must use a suitably qualified sensor.

Wiring scheme B, current measurement 4 to 20 mA with 4-wire transducer for application 3

You can interconnect six process signals with an analog module. Sensor supply V_S is provided by the analog module for 6 channels. The sensors can also be connected to an external sensor supply (see figure *External sensor supply, 4-wire transducer for SM 336; AI 6 x 13Bit* in chapter "Properties, front view, wiring diagram and block diagram (Page 196)").

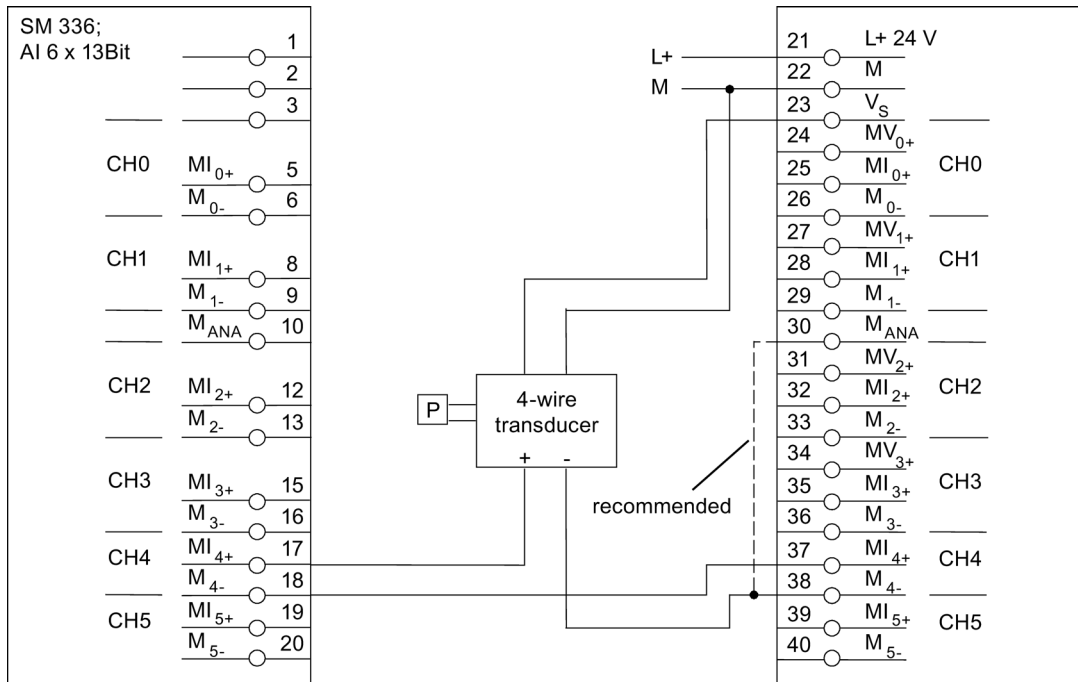

Figure 9-14 Current measurement 4 to 20 mA, 4-wire transducer for application 3 with SM 336; AI 6 x 13Bit

	WARNING
To achieve SIL3/Cat.4/PLe using this wiring, you must use a suitably qualified sensor.	

Assignable parameters for application 3

Table 9- 7 Parameters for application 3 of SM 336; AI 6 x 13Bit

Parameters	Range of values in safety mode	Type	Effective range
"Inputs 1" tab			
Enable diagnostic interrupt	Yes/no	Static	Module
Interference frequency	50 Hz/60 Hz	Static	Module
Group diagnostics	Yes/no	Static	Channel
Wire-break check (only for 4 to 20 mA)	Yes/no	Static	Channel
Measurement type	<ul style="list-style-type: none"> • Deactivated • 4DMU • 2DMU 	Static	Channel
Measuring range	4 to 20 mA	Static	Channel
"Inputs 2" tab			
Safety mode	<ul style="list-style-type: none"> • According to SIL 2 • 1 sensor 	Static	Module
Monitoring time	10 ms to 10000 ms	Static	Module
"Redundancy" tab			
Redundancy	none	Static	Module

9.2.7 Application 4: Safety mode SIL2/Cat.3/PLd with high availability (in S7 F/FH Systems only) [ID: 431732491]

Introduction

Below are the wiring schemes and the parameter assignment of SM 336; AI 6 x 13Bit for

- Application 4: Safety Mode SIL2/Cat.3/PLd with high availability.

Diagnostic messages, possible causes of the problem and their corrective measures are found in tables *Diagnostic messages of SM 336; AI 6 x 13Bit* and *Diagnostic messages and associated corrective measures for SM 336; AI 6 x 13Bit* in chapter "Diagnostic Messages for SM 336; AI 6 x 13 Bit (Page 232)".

Wiring scheme A, current measurement 4 to 20 mA with 2-wire transducer for application 4

You can interconnect six process signals with two redundant analog modules. Two sensors are connected via one channel to the two analog modules for each process signal. Sensor supply V_s is provided by the analog module for 6 channels. The sensors can also be connected to an external sensor supply (see figure *External sensor supply, 2-wire transducer for SM 336; AI 6 x 13Bit* in chapter "Properties, front view, wiring diagram and block diagram (Page 196)").

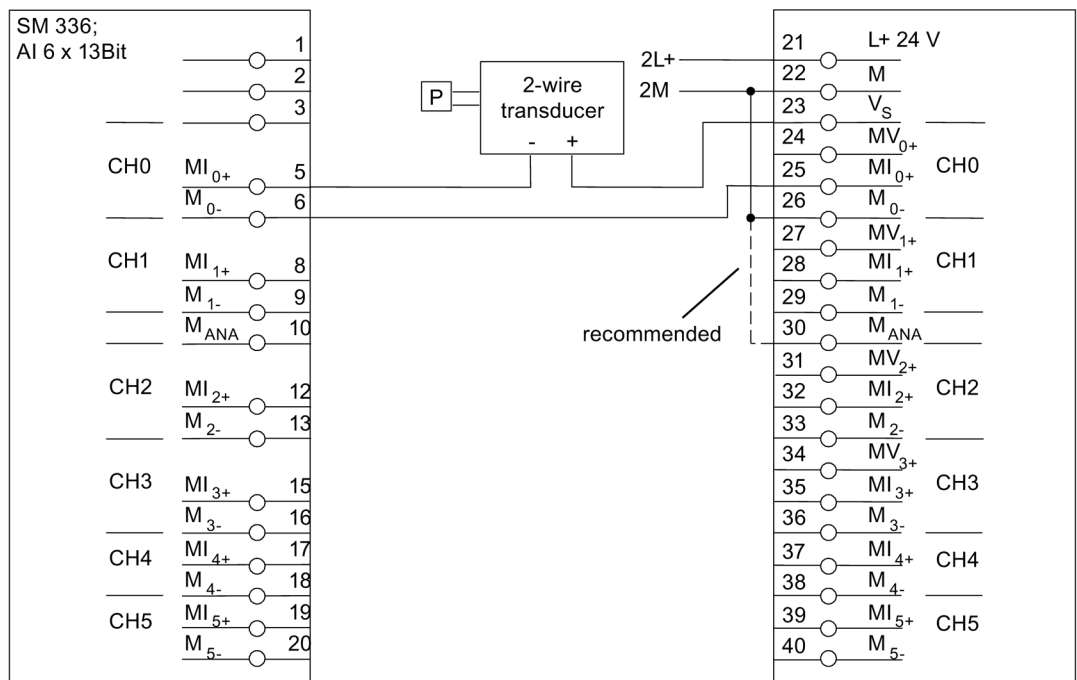
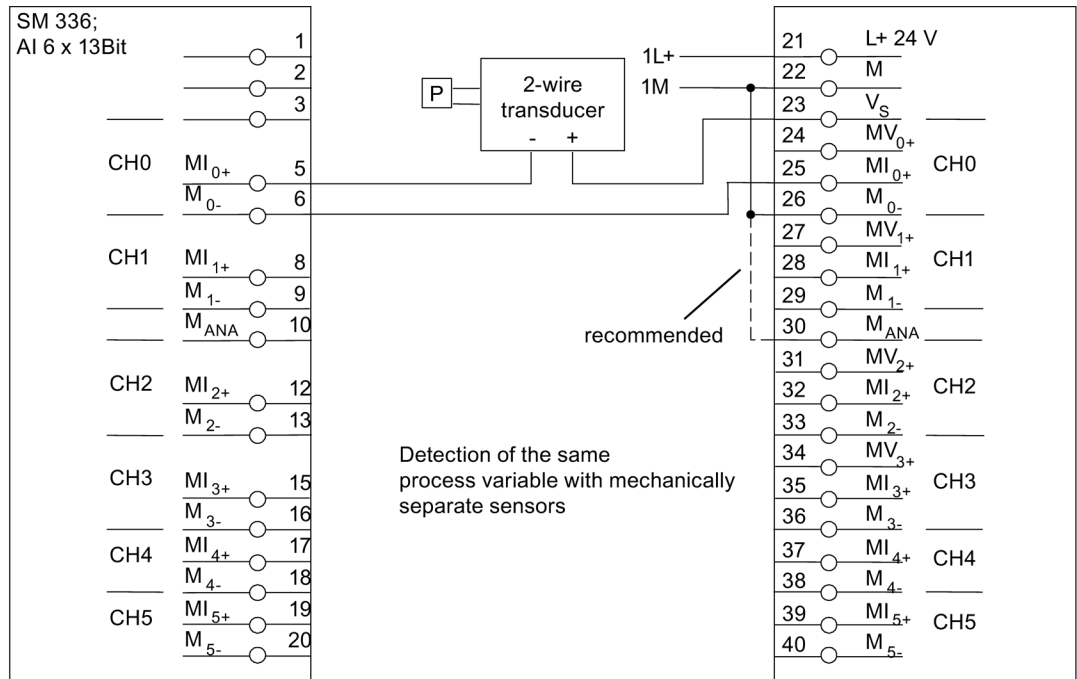

WARNING

To achieve SIL3/Cat.4/PLe using this wiring, you must use a suitably qualified sensor.

Wiring scheme B, current measurement 4 to 20 mA with 4-wire transducer for application 4

You can interconnect six process signals with two redundant analog modules. Two sensors are connected via one channel to the two analog modules for each process signal. Sensor supply V_s is provided by the analog module for 6 channels. The sensors can also be connected to an external sensor supply (see figure *External sensor supply, 4-wire transducer for SM 336; AI 6 x 13Bit* in chapter "Properties, front view, wiring diagram and block diagram (Page 196)").

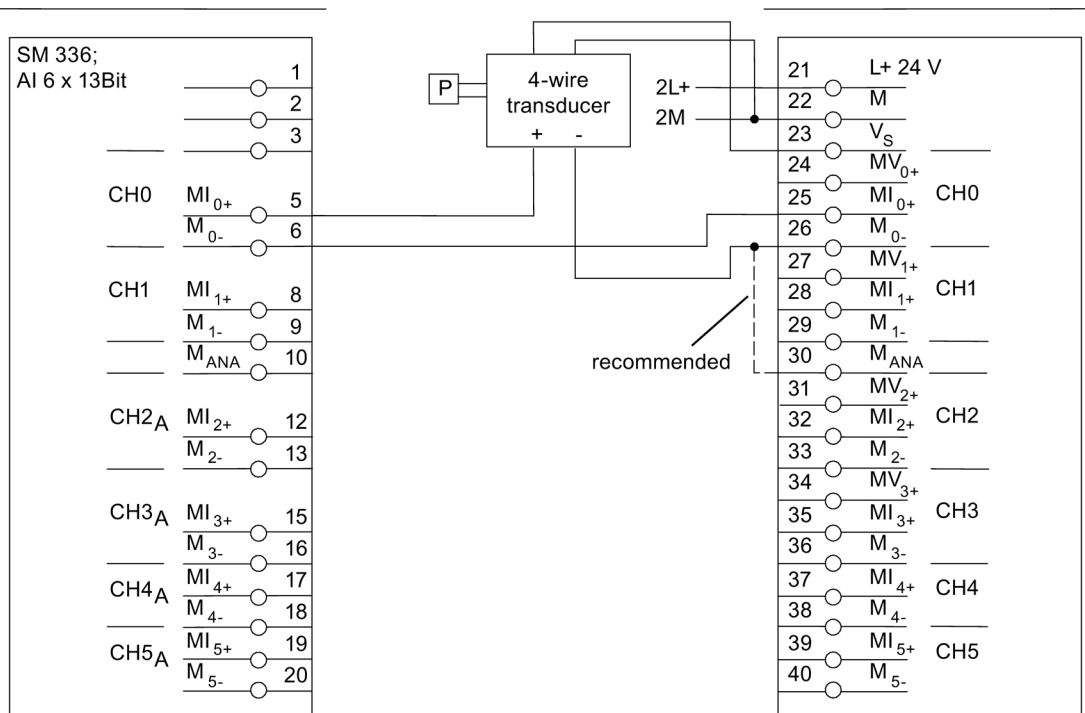
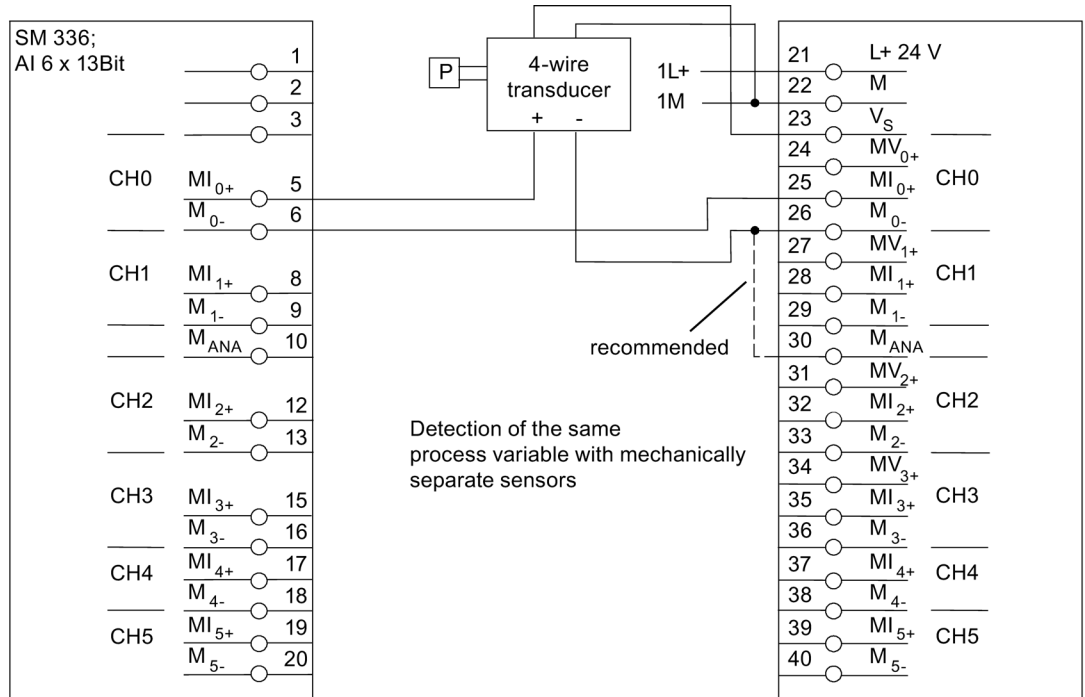

! WARNING

To achieve SIL3/Cat.4/PLe using this wiring, you must use a suitably qualified sensor.

Assignable parameters for application 4

Table 9- 8 Parameters for application 4 of SM 336; AI 6 x 13Bit

Parameters	Range of values in safety mode	Type	Effective range
"Inputs 1" tab			
Enable diagnostic interrupt	Activated/deactivated	Static	Module
Interference frequency	50 Hz/60 Hz	Static	Module
Group diagnostics	Activated/deactivated	Static	Channel
Wire-break check (only for 4 to 20 mA)	Activated/deactivated	Static	Channel
Measurement type	<ul style="list-style-type: none"> • Deactivated • 4DMU • 2DMU 	Static	Channel
Measuring range	4 to 20 mA	Static	Channel
"Inputs 2" tab			
Safety mode	<ul style="list-style-type: none"> • According to SIL 2 • 1 sensor 	Static	Module
Monitoring time	10 ms to 10000 ms	Static	Module
"Redundancy" tab			
Redundancy	2 modules	static	module
Redundant module	Selection of an existing additional module of the same type	static	Redundant module pair

9.2.8 Application 5: Safety mode SIL3/Cat.4/PLe [ID: 431735179]

Introduction

Below are the wiring schemes and the parameter assignment of SM 336; AI 6 x 13Bit for

- Application 5: Safety mode SIL3/Cat.4/PLe.

Diagnostic messages, possible causes of the problem and their corrective measures are found in tables *Diagnostic messages of SM 336; AI 6 x 13Bit* and *Diagnostic messages and associated corrective measures for SM 336; AI 6 x 13Bit* in chapter "Diagnostic Messages for SM 336; AI 6 x 13 Bit (Page 232)".

Wiring scheme A, current measurement 4 to 20 mA with 2-wire transducer for application 5

You can interconnect six process signals with an analog module. Two redundant sensors are connected to two *opposite inputs* of the analog module for each process signal (1oo2 evaluation). Sensor supply V_S is provided by the analog module for 6 channels. The sensors can also be connected to an external sensor supply (see figure *External sensor supply, 2-wire transducer for SM 336; AI 6 x 13Bit* in chapter "Properties, front view, wiring diagram and block diagram (Page 196)").

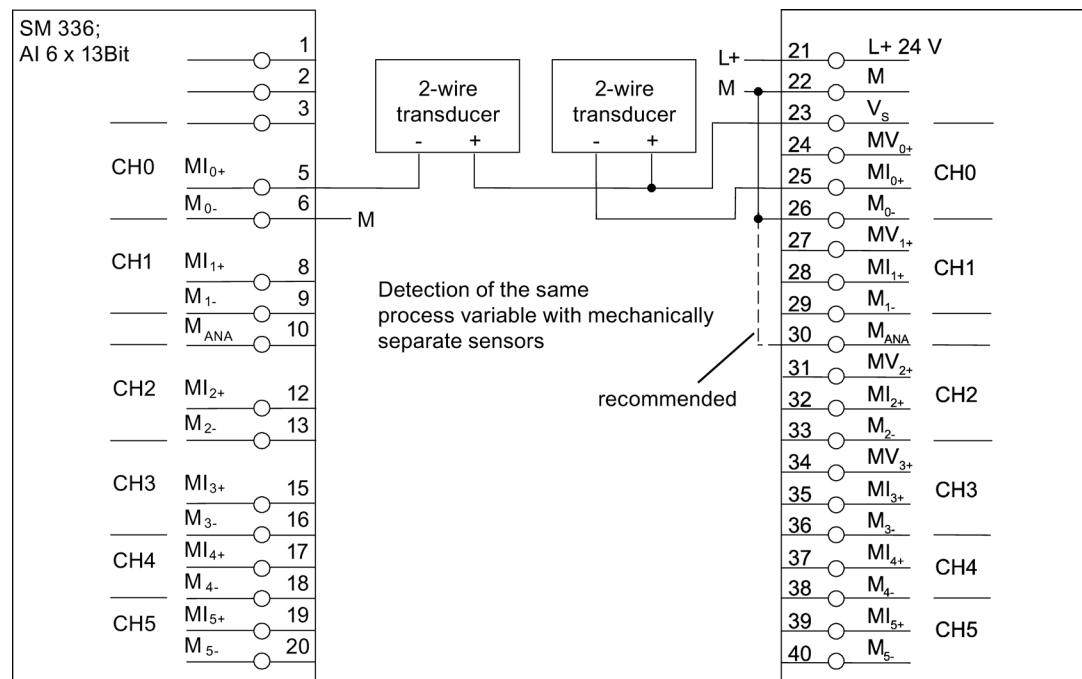

Figure 9-15 Current measurement 4 to 20 mA, 2-wire transducer for application 5 with SM 336; AI 6 x 13Bit

WARNING

To achieve SIL3/Cat.4/PLe using this wiring, you must use a suitably qualified sensor and it may require an 1oo2 evaluation.

Wiring scheme B, current measurement 4 to 20 mA with 4-wire transducer for application 5

You can interconnect six process signals with an analog module. Two redundant sensors are connected to two *opposite inputs* of the analog module for each process signal (1oo2 evaluation). Sensor supply V_s is provided by the analog module for 6 channels. The sensors can also be connected to an external sensor supply (see figure *External sensor supply, 4-wire transducer for SM 336; AI 6 x 13Bit* in chapter "Properties, front view, wiring diagram and block diagram (Page 196)").

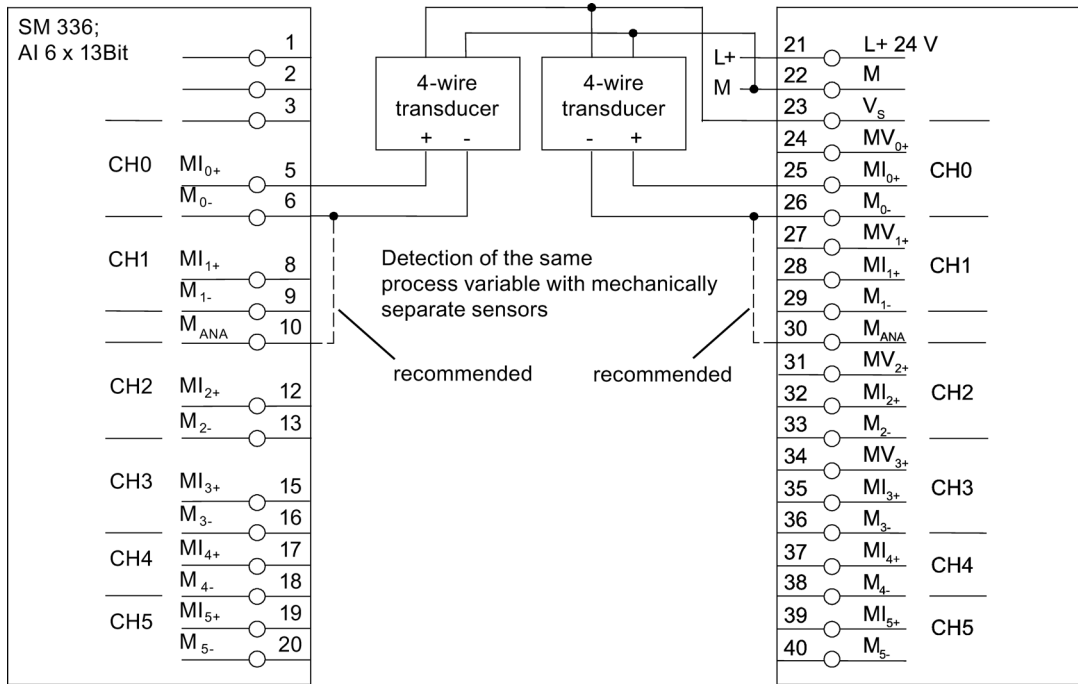



Figure 9-16 Current measurement 4 to 20 mA, 4-wire transducer for application 5 with SM 336; AI 6 x 13Bit

 WARNING
<p>To achieve SIL3/Cat.4/PLe using this wiring, you must use a suitably qualified sensor and it may require an 1oo2 evaluation.</p>

Assignable parameters for application 5

Table 9- 9 Parameters for application 5 of SM 336; AI 6 x 13Bit

Parameters	Range of values in safety mode	Type	Effective range
"Inputs 1" tab			
Enable diagnostic interrupt	Activated/deactivated	Static	Module
Interference frequency	50 Hz/60 Hz	Static	Module
Group diagnostics	Activated/deactivated	static	channel
Wire-break check	Activated/deactivated	Static	Channel
Measurement type	<ul style="list-style-type: none"> • Deactivated • 4DMU • 2DMU 	Static	Channel
Measuring range	4 to 20 mA	Static	Channel
"Inputs 2" tab			
Safety mode	<ul style="list-style-type: none"> • According to SIL 3 • 2 sensors 	Static	Module
Monitoring time	10 ms to 10000 ms	static	module
Discrepancy time	10 to 10000 ms	static	module
Tolerance window in terms of the measuring range	0 to 20% in 1% increments	Static	Module
Standard value	MIN/MAX	Static	Module
"Redundancy" tab			
Redundancy	none	Static	Module

Discrepancy analysis for fail-safe analog input modules

If you have configured safety mode in accordance with SIL 3, you can configure a discrepancy time and an absolute tolerance window (as a % of the 4 mA to 20 mA measuring range) for each input of the analog input module. In addition, configure the standard value (MIN = lower value / MAX = higher value) to be applied and transferred to the F-CPU.

If the difference between the two measured values is outside of the tolerance window for longer than the configured discrepancy time, this error is signaled and the fail-safe value (7FFF_H) is transferred. In *S7 Distributed Safety*, the fail-safe value 0 is provided in the PII for the safety program in place of 7FFF_H.

9.2.9 Application 6: Safety mode SIL3/Cat.4/PLe with high availability (in S7 F/FH Systems only) [ID: 431737867]

Introduction

Below are the wiring schemes and the parameter assignment of SM 336; AI 6 x 13Bit for

- Application 6: Safety Mode SIL3/Cat.4/PLe with high availability.

Diagnostic messages, possible causes of the problem and their corrective measures are found in tables *Diagnostic messages of SM 336; AI 6 x 13Bit* and *Diagnostic messages and associated corrective measures for SM 336; AI 6 x 13Bit* in chapter "Diagnostic Messages for SM 336; AI 6 x 13 Bit (Page 232)".

Wiring scheme A, current measurement 4 to 20 mA with 2-wire transducer for application 6

You can interconnect six process signals with two redundant analog modules. Four redundant sensors are required for each process signal. Two sensors are connected via two channels to two *opposite inputs* of the analog module for each module (1oo2 evaluation). Sensor supply V_S is provided by the analog module for 6 channels. The sensors can also be connected to an external sensor supply (see figure *External sensor supply, 2-wire transducer for SM 336; AI 6 x 13Bit* in chapter "Properties, front view, wiring diagram and block diagram (Page 196)").

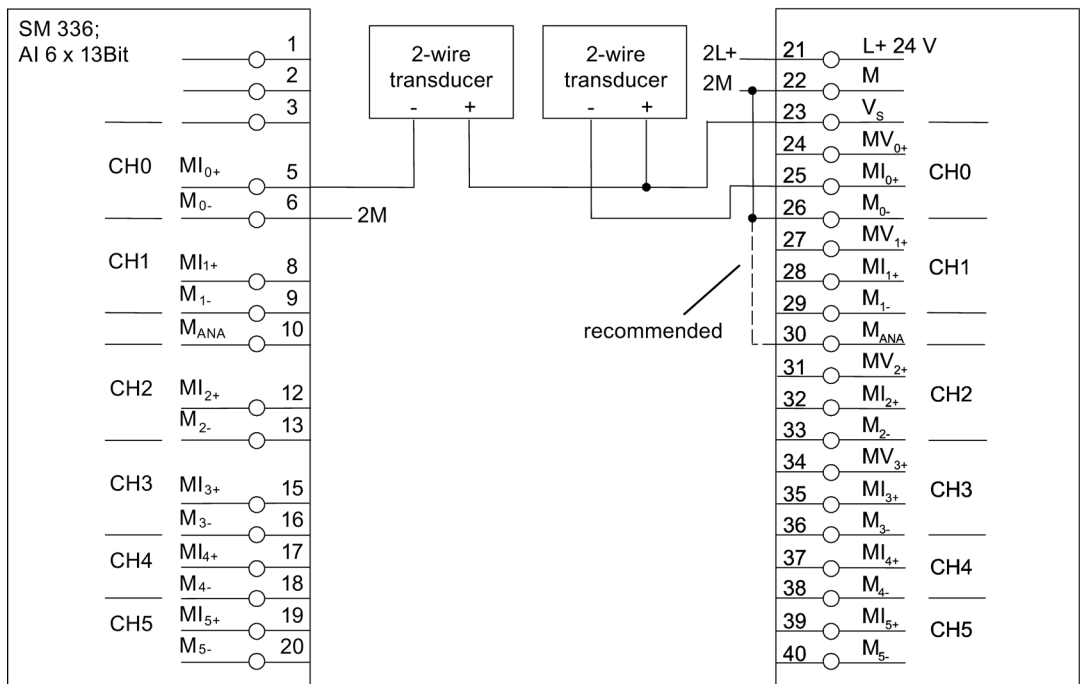
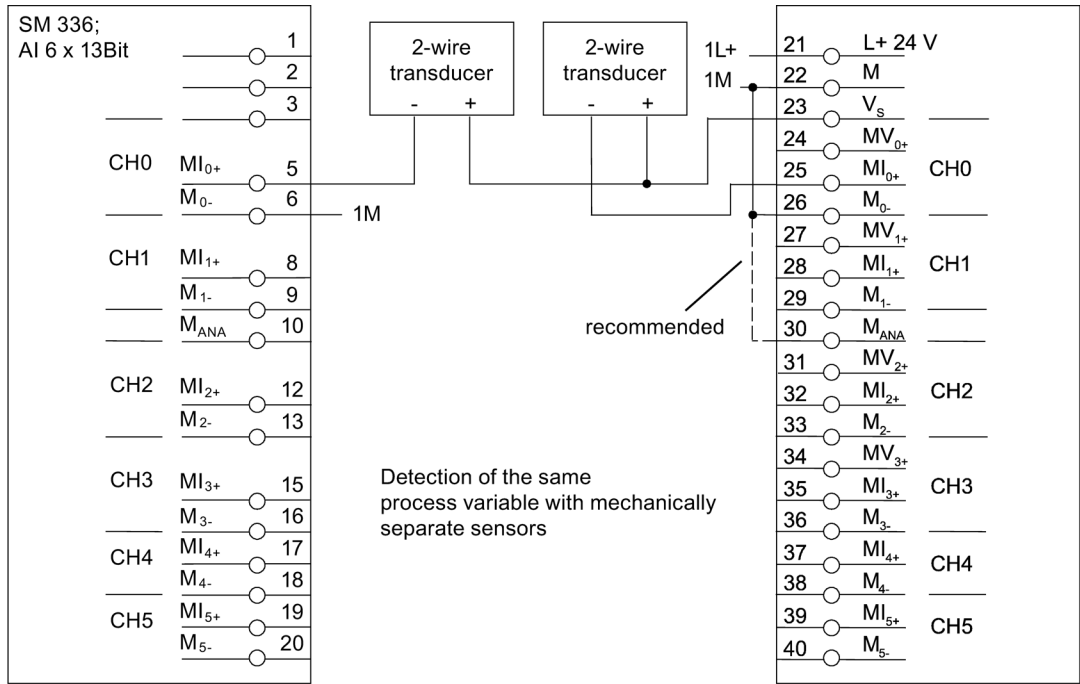

WARNING

To achieve SIL3/Cat.4/PLE using this wiring, you must use a suitably qualified sensor.

Wiring scheme B, current measurement 4 to 20 mA with 4-wire transducer for application 6

You can interconnect six process signals with two redundant analog modules. Four redundant sensors are required for each process signal. Two sensors are connected via two channels to two *opposite inputs* of the analog module for each module (1oo2 evaluation). Sensor supply V_S is provided by the analog module for 6 channels. The sensors can also be connected to an external sensor supply (see figure *External sensor supply, 4-wire transducer for SM 336; AI 6 x 13Bit* in chapter "Properties, front view, wiring diagram and block diagram (Page 196)").

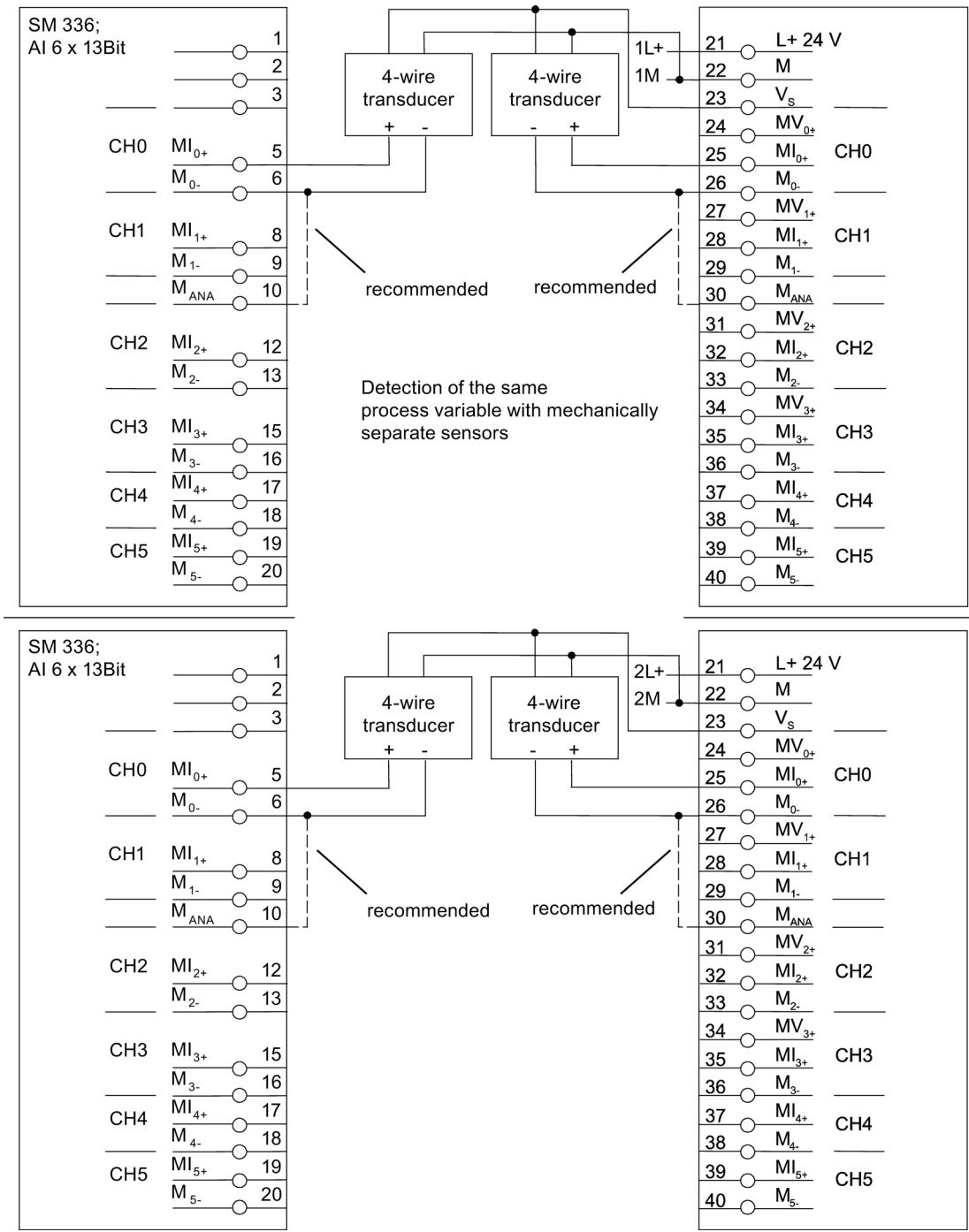

⚠ WARNING
 To achieve SIL3/Cat.4/PLe using this wiring, you must use a suitably qualified sensor.

Assignable parameters for application 6

Table 9- 10 Parameters for application 6 of SM 336; AI 6 x 13Bit

Parameters	Range of values in safety mode	Type	Effective range
"Inputs 1" tab			
Enable diagnostic interrupt	Activated/deactivated	Static	Module
Interference frequency	50 Hz/60 Hz	Static	Module
Group diagnostics	Activated/deactivated	static	channel
Wire-break check (only for 4 to 20 mA)	Activated/deactivated	Static	Channel
Measurement type	<ul style="list-style-type: none"> • Deactivated • 4DMU • 2DMU 	Static	Channel
Measuring range	4 to 20 mA	Static	Channel
"Inputs 2" tab			
Safety mode	<ul style="list-style-type: none"> • According to SIL 3 • 2 sensors * 	Static	Module
Monitoring time	10 ms to 10000 ms	static	module
Discrepancy time	0 ms to 30000 ms	static	module
Tolerance window in terms of the measuring range	1 to 20% in 1% increments	Static	Module
Standard value	MIN/MAX	Static	Module
"Redundancy" tab			
Redundancy	2 modules	static	module
Redundant module	Selection of an existing additional module of the same type	static	Redundant module pair
* If you are evaluating sensors in your safety program (e.g., in <i>S7 F Systems</i> using F-block F_1oo2AI), configure "1 sensor".			

Discrepancy analysis for fail-safe analog input modules

If you have configured safety mode in accordance with SIL 3, you can configure a discrepancy time and an absolute tolerance window (as a % of the 4 mA to 20 mA measuring range) for each input of the analog input module. In addition, configure the standard value (MIN = lower value / MAX = higher value) to be applied and transferred to the F-CPU.

If the difference between the two measured values is outside of the tolerance window for longer than the configured discrepancy time, this error is signaled and the fail-safe value (7FFF_H) is transferred. In *S7 Distributed Safety*, the fail-safe value 0 is provided in the PII for the safety program in place of 7FFF_H.

9.2.10 Diagnostic Messages for SM 336; AI 6 x 13 Bit [ID: 431743243]

Possible diagnostic messages

The following table provides an overview of the diagnostic messages for SM 336; AI 6 x 13Bit.

Diagnostic messages are assigned either to a channel or to the entire module. Some diagnostic messages occur only in certain applications.

Table 9- 11 Diagnostic messages of SM 336; AI 6 x 13Bit

Diagnostic message	Signaled in the application		Effective range of diagnostics	Assignable
Wire break	1, 2, 3, 4, 5, 6	A, B	Channel	Yes
Discrepancy error	4, 6			
Common mode fault	1, 2, 3, 4, 5, 6	A, B, C	Channel	No
Overflow or underflow of the measured value (see "Wire break and underflow" in Chapter " Analog value representation (Page 194) ")	1, 2, 3, 4, 5, 6	A, B, C		
Incorrect module parameters	1, 2, 3, 4, 5, 6	A, B, C	module	
Parameter assignment error (with specification of consecutive number)				
ADC/DAC error				
No external auxiliary voltage				
Communications error (CPU in Stop)				
Time monitoring activated (watchdog)				
EPRAM / RAM fault				
Processor failure				
CRC signature error				
Timeout of safety message frame monitoring				
Message frame error	1, 2			

Causes of the problem and corrective measures

The table below shows possible causes of the problem and appropriate corrective measures for the individual diagnostic messages of SM 336; AI 6 x 13Bit.

Table 9- 12 Diagnostic messages and associated corrective measures for SM 336; AI 6 x 13Bit

Diagnostic message	Possible causes of the problem	Corrective measures
Wire break (only in the 4 to 20 mA measuring range)	Interruption of the measuring lead between the module and sensor	Reestablish the cable connection
	Incorrect measuring range setting	Set the 4 to 20 mA measuring range
Discrepancy error	Assigned tolerance window exceeded on expiration of the discrepancy time	Extend the tolerance window and/or discrepancy window
	Wire break	Eliminate the wire break Check the process signal.
	Deviation between two inputs outside limits of safety mode to SIL 2	Wiring error: wire the analog signal to both inputs, or replace the module
Common mode fault	Potential difference U_{CM} between the inputs (M-) and reference potential of measuring circuit (M_{ANA}) too high.	Interconnect M- with M_{ANA}
Overflow or underflow of the measured value (see "Wire break and underflow") in Chapter "Analog value representation (Page 194)")	Measuring range fallen below	Use a suitable sensor; check the wiring (sensor polarity reversed)
	Measuring range exceeded	Use a suitable sensor; sensor polarity reversed
	Current through sensor too high at startup	—
Incorrect module parameters	Faulty parameters transferred to module	Assign new module parameters
Parameter assignment error (with specification of a consecutive number; for example, "16": incorrect address)	Error in dynamic parameter reassignment	Check the parameter assignment in the user program Contact SIMATIC Customer Support if necessary
ADC/DAC error	Internal error during analog value test	Replace the module
	Internal voltage monitoring has reported a fault	
No external auxiliary voltage	Module supply voltage L+ missing	Connect supply voltage L+
Communication error	Error in communication between the CPU and the module, for example, due to defective PROFIBUS connection or electromagnetic interference in excess of limits.	Check the PROFIBUS connection Eliminate the interference
	Timeout of safety message frame monitoring	Check the monitoring time parameters

Diagnostic message	Possible causes of the problem	Corrective measures
	CRC signature error, for example, due to electromagnetic interference in excess of limits.	Eliminate the interference
	CPU is in STOP	Read the diagnostics buffer
Time monitoring activated (watchdog)	Excessive electromagnetic interference at times	Eliminate the interference
	Defective module	Replace the module
EPROM fault RAM fault	Excessive electromagnetic interference at times	Eliminate the interference and cycle power OFF/ON
	Defective module	Replace the module
Processor failure	Electromagnetic interference has exceeded limits	Eliminate the interference
	Defective module	Replace the module
	Switching rate exceeded	Reduce switching rate
CRC signature error	CRC signature error during communication between the CPU and the module has occurred, for example, due to electromagnetic interference in excess, faults during sign-of-life monitoring error or standard program accesses F-SM.	Eliminate the interference
Timeout of safety message frame monitoring	Assigned monitoring time exceeded	Check the monitoring time parameters
	Startup of the fail-safe signal module	—
Message frame error	Sign-of-life and/or CRC signature entered in the data message frame	Check the sign-of-life and CRC signature entries in the data message frame for "0" value

9.2.11 Technical data - SM 336; AI 6 x 13Bit [ID: 8681228811]

Overview

Technical specifications	
Dimensions and weight	
Dimensions W x H x D (mm)	80 x 125 x 120
Weight	Approx. 480 g
Module-specific specifications	
Number of inputs	6
Assigned address area	
• In the I/O input area	16 bytes
• In the I/O output area	4 bytes
Cable length	
• Shielded	Max. 200 m
Front connectors	40-pin
Maximum achievable Safety Integrity Level in safety mode	
• According to IEC 61508:2000	Max. SIL 3
• According to ISO 13849-1:2006 or EN ISO 13849-1:2008	Max. Cat. 4/PLe
Fail-safe performance characteristics	
• low demand mode (average probability of failure on demand) SIL 3	< 1.00E-05
• high demand / continuous mode (probability of a dangerous failure per hour)SIL 3	< 1.00E-09
Proof-test interval	10 years
Surge protection of supply voltages L+ and L _{ext} in accordance with IEC 1000-4-5 (internal)	±0.5 kV, 1.2/50 µs
Surge protection of analog inputs and sensor supply voltage in accordance with IEC 1000-4-5 (internal)	±2 kV, 1.2/50 µs
Voltages, currents, potentials	
Rated supply voltage of electronics L+	24 V DC
• Reverse polarity protection	Yes
• Power failure ride-through	5 ms
Electrical isolation	
• Between channels and backplane bus	Yes
• Between channels and the power supply of the electronics	Yes, only with external sensor supply

Technical specifications	
• Between channels	No
• Between the power supply and sensor supply	No
Permitted potential difference	
• Between inputs and M_{ANA} (U_{CM})	6.0 V DC
• Between M_{ANA} and M_{Intern} (U_{ISO})	75 V DC, 60 V AC
Insulation test voltage	500V DC / 350V AC for 1min or 600V DC for 1s
Current consumption	
• From backplane bus	Max. 90 mA
• From supply voltage L+	Typ. 160 mA
Common-mode voltage (CMV)	
• Permitted common mode voltage between the inputs (U_{CM})	Max. ± 6 V
• Monitoring of common mode voltage	Yes, operating range > 6 V or < -6 V
Power loss of the module	4.25 W, typical
Analog value generation	
Measuring principle	Integrating
Integration/conversion time	
• Configurable	Yes
• Integration time	
At 50 Hz	20.00 ms
At 60 Hz	16.66 ms
• Resolution, including overrange	13 bits + sign
Response time per activated channel	
• At 50 Hz	Max. 50 ms
• At 60 Hz	Max. 44 ms
Basic response time	
• At 50 Hz	Max. 50 ms
• At 60 Hz	Max. 44 ms
Acknowledgment time corresponds to Max. response time = max. response time per channel \times N + max. basic response time (N = number of active channels)	

Technical specifications	
Noise suppression, error limits	
Noise suppression for $f=n \times (50/60 \text{ Hz} \pm 1\%)$, $n=1, 2, \text{ etc.}$	Min. 38 dB
Common-mode interference ($U_{CM} \leq 6 V_{r.m.s.}$)	Min. 75 dB
Crosstalk between inputs	Min. 75 dB
Basic error limit (operational limit at 25 °C, relative to input range)	
• Current input	$\pm 0.40\%$
• Voltage input	$\pm 0.40\%$
Temperature error (relative to input range)	$\pm 0.002\%/K$
Linearity error (relative to input range)	$\pm 0.05\%$
Repeatability (in transient state at 25 °C, relative to input range)	$\pm 0.05\%$
Operational limit (across the temperature range, relative to input range)	
• Current	$\pm 0.48\%$
• Voltage	$\pm 0.48\%$
Status, Interrupts, Diagnostics	
Interrupts	
• Process interrupt	No
• Diagnostic interrupt	Yes, assignable
Diagnostics functions	
• Indication of safety-oriented operation	Green LED (SAFE)
• Sensor supply monitoring	Green LED (Vs)
• Group fault display	Red LED (SF)
• Diagnostic information can be read out	Yes
Fail-safe values can be switched to	Configurable in safety program

Technical specifications	
Sensor supply output	
• Number of outputs	1
Output voltage	
• Loaded	Minimum L+ (-1.5 V)
Output current	
• Rated value	1.0 A
• Approved range	0 to 1.3 A
Short-circuit protection	Yes, electronic
Electrical isolation in accordance with DIN VDE 0160	
• Between output Vs and the backplane bus	Yes
• Between output and L+	No
• Test voltage	600 V DC
• Rated insulation voltage	75 V DC/60 V AC
Sensor selection data	
Input range (rated values)/input resistance in standard mode	
• Voltage	0 to 10 V/59 k Ω
• Current	0 mA to 20 mA 4 to 20 mA/107 Ω
Input range (rated values)/input resistance in safety mode	
• Current	4 to 20 mA/107 Ω
Permitted input voltage for voltage input (destruction limit)	Max. 30 V continuous; Max. 38 V for max. 1 s (pulse duty factor 1:20)
Permitted input current for current input (destruction limit)	Max. 40 mA
Signal sensor connection	
• For voltage measurement	Possible
• For current measurement	Possible
• As 4-wire transducer	Possible
• As 2-wire transducer	Possible
• Load of 2-wire transducer	Max. 600 Ω

Note

The maximum cable lengths currently specified in this manual ensure against functional impairment, even without more precise examination of the boundary conditions. If the boundary conditions, such as EMC, cable type, cable routing, etc. are examined more closely, longer cables can be used for all F-SMs.

9.3 SM 336; F-AI 6 x 0/4 ... 20 mA HART

9.3.1 Analog value representation [ID: 6735162891]

Measured value ranges

Table 9- 13 Measured value ranges of SM 336; F-AI 6 x 0/4 ... 20 mA HART

Measuring range			Unit		Range
0 to 20 mA	4 to 20 mA	as percentage of the nominal range	Decimal	Hexadecimal	
> 23.518 mA	> 22.814 mA	> 117,589	32767	7FFF _H ²	Overflow
23.518 mA	22.814 mA	117,589	32511	7EFF _H	Overrange
·	·	·	·	·	
20.0007 mA	20.0006 mA	100,004	27649	6C01 _H	Nominal range
20 mA	20 mA	100	27648	6C00 _H	
·	·	·	·	·	
0.4442 mA	·	2,221	614	266 _H	
< 0.4442 mA	·	·	·	·	
·	4 mA + 578.7 nA	0,0036	1	1 _H	Underflow
723.4 nA	·	·	·	·	
0 mA (7FFF _H)	4.00 mA	0	0	0 _H	
7FFF _H ¹	3.9995 mA	-0,0036	-1	FFFF _H	Underflow
·	·	·	·	·	
·	0.4444 mA	-22,222	-6144	E800 _H	Underflow
7FFF _H	< 0.4444 mA (see below)	< -22,222	-32768	8000 _H ²	

¹ The module is signaling a wire break, 7FFF_H.

² In *S7 F/FH Systems* a fail-safe value is output for this value in the safety program when overflow or underflow is detected.

In *S7 Distributed Safety*, the fail-safe value 0 is provided in the PII for the safety program in place of 7FFF_H (for overflow) and 8000_H (for underflow).

See also the "S7-300 Automation System module data (<http://support.automation.siemens.com/WW/view/en/8859629>)" operating instructions.

Wire-break check in the range of 0 to 20 mA

In the range 0 to 20 mA, a wire-break check is always performed:

- Wire break at < 0.4442 mA with 7FFF_H in *S7 F/FH Systems* is reported and the fail-safe value will be output as configured at the input SUBS_V of the F channel driver. In *S7 Distributed Safety*, the fail-safe value 0 is provided in the PII for the safety program in place of 7FFF_H.

Wire-break check and underflow check in the range 4 to 20 mA

In the range 4 to 20 mA, a check is made to determine whether wire-break check is assigned.

- If wire-break check is assigned, an underflow check is not performed. Wire break at < 3,6 mA with 7FFF_H in *S7 F/FH Systems* is reported and the fail-safe value will be output as configured at the input SUBS_V of the F channel driver. In *S7 Distributed Safety*, the fail-safe value 0 is provided in the PII for the safety program in place of 7FFF_H.
- If no wire break is assigned, in case of an underflow at < 0.4444 mA with 8000_H in *S7 F/FH Systems* is reported and the fail-safe value will be output as configured at the input SUBS_V of the F channel driver. In *S7 Distributed Safety*, the fail-safe value 0 is provided in the PII for the safety program in place of 8000_H (for underflow).

Measured value resolution

SM 336; F-AI 6 x 0/4 ... 20 mA HART has a 15-bit resolution.

Table 9- 14 Representation of the bit pattern

Bit number	15	14	13	12	11	10	9	8	7	6	5	4	3	2	1	0
Bit significance	Sign	2 ¹⁴	2 ¹³	2 ¹²	2 ¹¹	2 ¹⁰	2 ⁹	2 ⁸	2 ⁷	2 ⁶	2 ⁵	2 ⁴	2 ³	2 ²	2 ¹	2 ⁰
Example	0	1	0	0	1	1	0	0	1	1	1	1	1	1	0	1

Table 9- 15 Resolution

Measuring range	% of nominal range	Resolution
0 to 20 mA	0,0036	723.4 nA
4 to 20 mA	0,0036	578.7 nA

9.3.2 Properties, front view, wiring diagram and block diagram [ID: 6648476043]

Order number

6ES7336-4GE00-0AB0

Properties

SM 336; F-AI 6 x 0/4 ... 20 mA HART has the following properties:

- 6 analog inputs with electrical isolation between channels and the backplane bus
- Input ranges:
 - 0 to 20 mA
 - 4 to 20 mA
- Short circuit-proof power supply of 2- or 4-wire transducers by the module
- External sensor supply possible
- Group fault display (SF)
- Safety mode display (SAFE)
- Display for channel-specific fault (Fn)
- Display for HART status (Hn)
(If you have activated HART communication for a channel and HART communication is running, the green HART status display lights up.)
- Programmable diagnostics functions
- Programmable diagnostic interrupt
- Supports operation in safety mode
- SIL3/Cat.4/PLe can be achieved without safety protector
- HART communication
- Firmware update via *HW Config*
- I&M identification data
- Can be used with PROFINET IO

Use of inputs

You can use the inputs as follows:

- Each of the 6 channels for current measurement
 - 0 to 20 mA (without HART utilization)
 - 4 to 20 mA (with/without HART utilization)
- Functional range of HART communication: 1.17 to typ. 35 mA

Address assignment

The following figure shows the assignment of channels to addresses.

Addressing of the inputs in the user program:

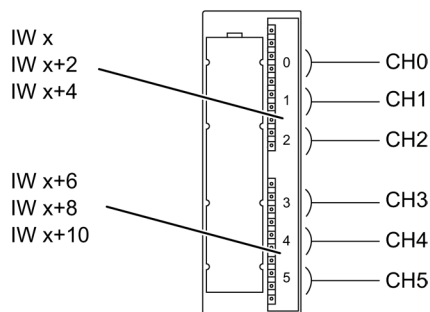

x = Module start address

Figure 9-17 Address assignment for SM 336; F-AI 6 x 0/4 ... 20 mA HART

Front view

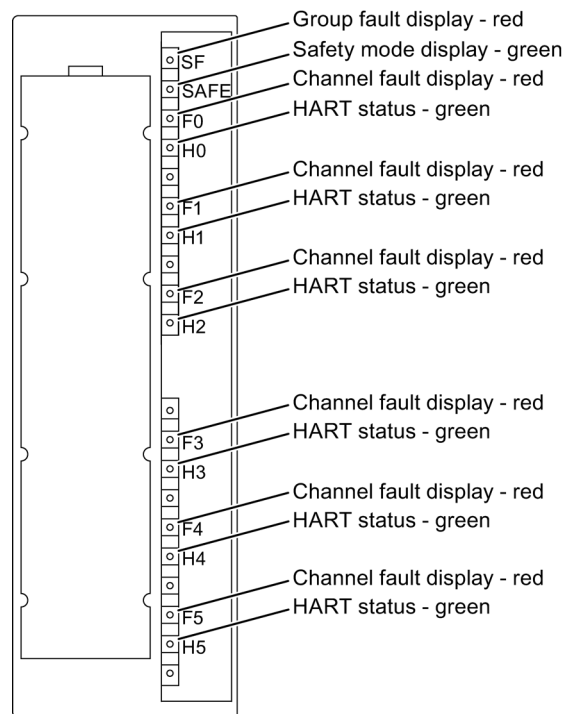

Figure 9-18 Front view SM336; F-AI 6 x 0/4 ... 20 mA HART

Wiring and block diagram

The following figure shows the the wiring and block diagram of SM 336; F-AI 6 x 0/4 ... 20 mA HART. The wiring and block diagrams of analog sensors for the different applications are shown in the next sections.

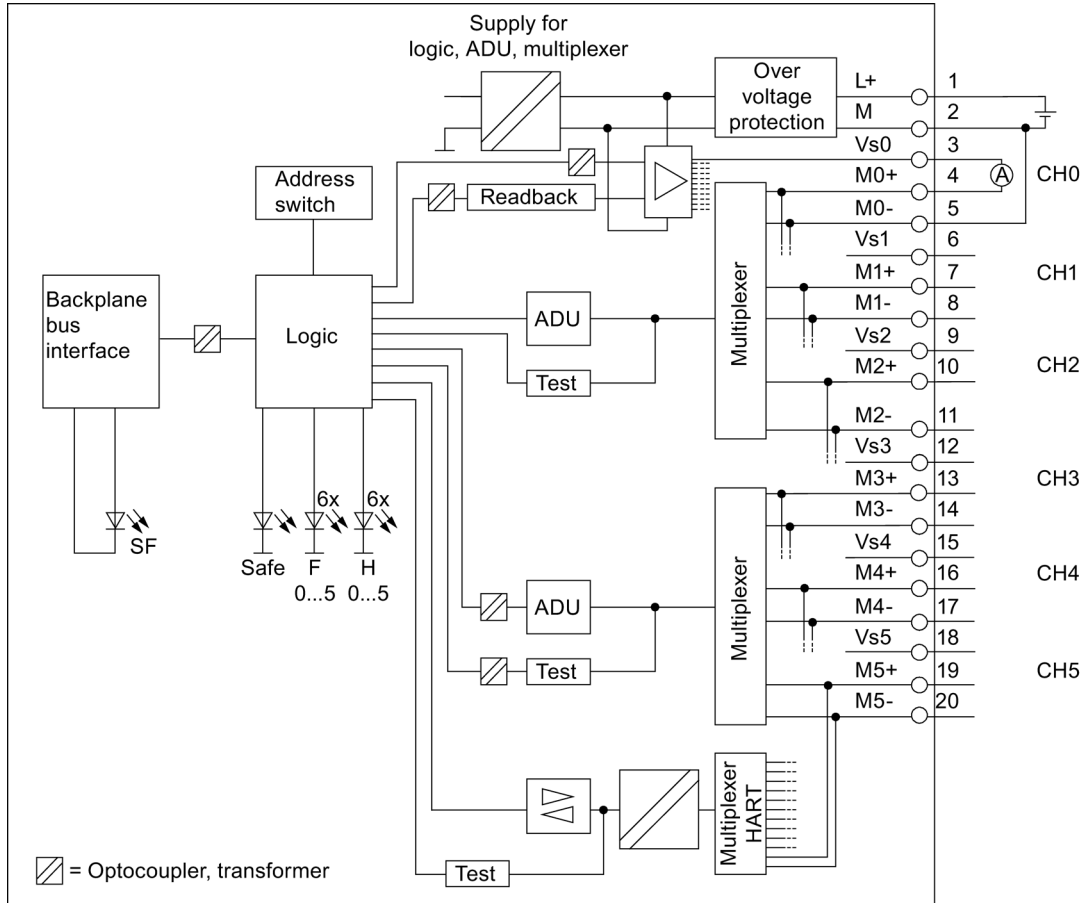

Figure 9-19 Wiring and block diagram of SM 336; F-AI 6 x 0/4 ... 20 mA HART

Channel numbers

The channel numbers are used to uniquely identify the inputs and to assign channel-specific diagnostic messages.

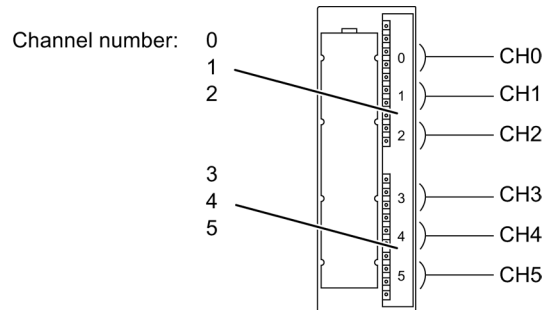

Figure 9-20 Channel numbers SM 336; F-AI 6 x 0/4 ... 20 mA HART

Sensor supply

⚠ WARNING

Voltage dips of the power supply are not buffered by the module and, thus, affect the sensor supply.

This can cause the measured value to be false.

You can avoid voltage dips by using a voltage supply according to the NAMUR recommendation (see section "Safe Functional Extra-Low Voltage for Fail-Safe Signal Modules (Page 46)"). Alternatively, use a transducer with an appropriate battery backup or diagnostics.

Recommendation: Internal sensor supply

You are strongly advised to use the short circuit-proof internal sensor supply of the module. This internal sensor supply is monitored and its status is indicated by the Fn LED (see Figure *Front view of SM 336; F-AI 6 x 0/4 ... 20 mA HART*).

Note

The internal sensor supply of the associated channel is switched off in case of an overload of the analog input or short circuit to ground or during power-up in the event of short circuit to L+ to protect the input.

A check is made approximately 1 minute later to determine if the error has gone.

External sensor supply

The figures in section "Auto-Hotspot" show how you can supply power to the sensors via an external sensor supply (for example, from another module).

 **WARNING**

If there is a short circuit from L+ to Mn+, the input resistors will be destroyed.

You can avoid this problem through proper wiring and use of the internal sensor supply. When an external sensor supply is used, other suitable measures are necessary to protect the input resistors (e.g. fuse on the module).

 **WARNING**

The **stability** of the external sensor supply must conform to the desired safety requirement class SIL 2, 3. To ensure that the sensor functions problem-free, we recommend one of the following options:

- Use of a **redundant** external sensor supply
or
- **Monitoring** of the external sensor supply for undervoltage/overvoltage, including shutdown of the sensor supply when a fault is detected (single-channel for SIL 2; dual-channel for SIL 3)

Isolated transducers

The isolated transducers are not bonded to local earth potential. These transducers can be operated with floating potential. Local conditions or interference may cause potential differences U_{CM} (static or dynamic) between the measuring lines M- of the input channels and the reference point of measuring circuit M.

Note

It is advisable to wire M- to M in order to prevent common mode voltages in excess of the permitted value for U_{CM} when operating the equipment in areas subject to heavy EMC interference.

Non-isolated transducers

The non-isolated transducers are bonded to local earth potential. Always interconnect M with earth potential. Local conditions or interference may cause potential differences U_{CM} (static or dynamic) between the locally distributed measuring points.

If common mode voltage exceeds the permitted value for U_{CM} , you must provide for equipotential bonding conductors between the measuring points.

See also

Applications of SM 336; F-AI 6 x 0/4 ... 20 mA HART (Page 247)

9.3.3 Applications of SM 336; F-AI 6 x 0/4 ... 20 mA HART [ID: 56063021707]

Selecting the application

The figure below helps you to select an application based on availability and fail-safe operation requirements. The next pages provide information on the module wiring and parameter settings in *STEP 7*.

Applications 1 and 2 are omitted because the module supports only safety mode.

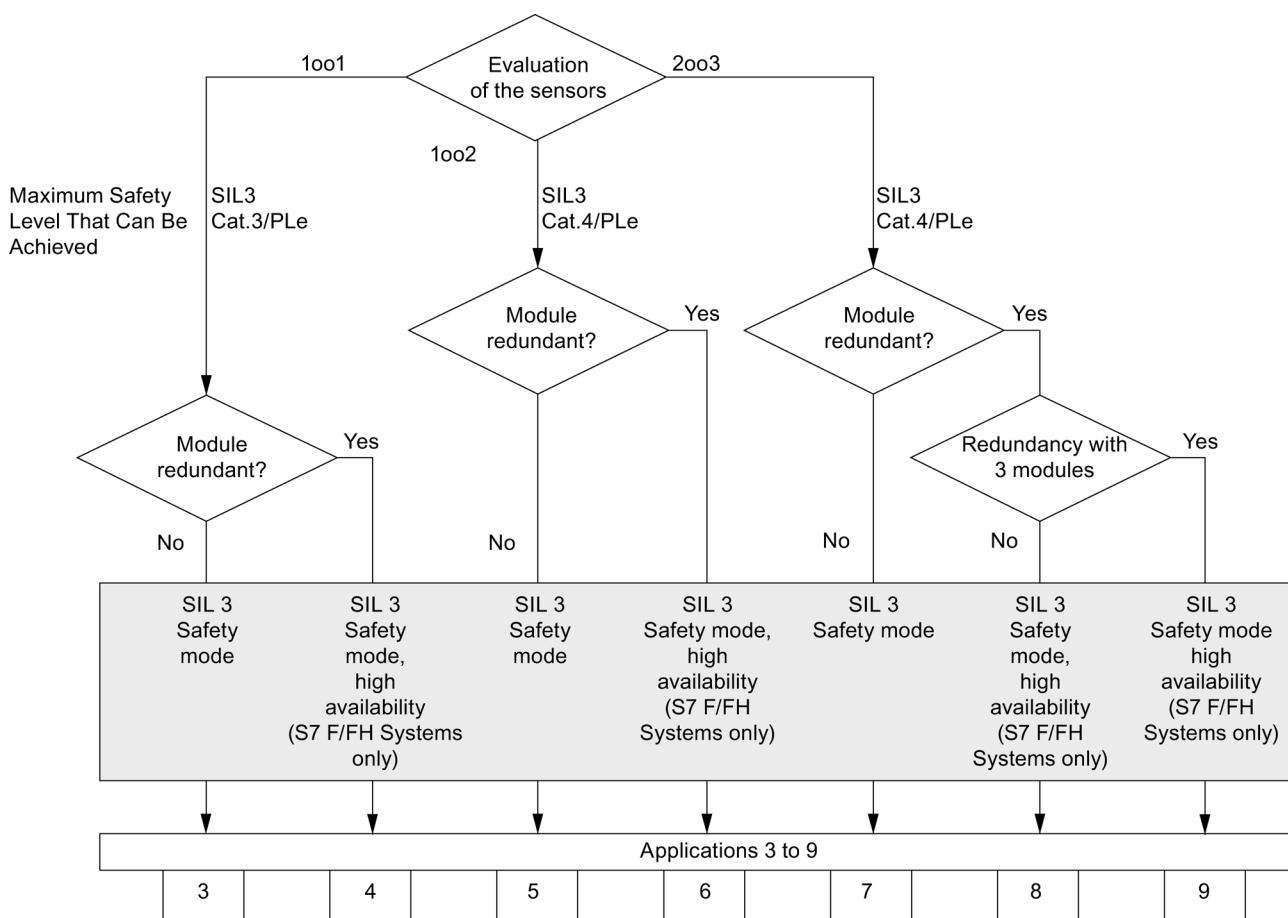

Figure 9-21 Applications

⚠ WARNING

The maximum Safety Integrity Level is determined by the sensor quality and the length of the proof-test interval according to the IEC 61508:2000 standard. If the sensor quality does not meet Safety Integrity Level requirements, always wire redundant sensors and connect them via two channels.

⚠ WARNING

If there is a short circuit from L+ to Mn+, the input resistors will be destroyed.

You can avoid this problem through proper wiring and use of the internal sensor supply. When an external sensor supply is used, other suitable measures are necessary to protect the input resistors (e.g. fuse on the module).

Wiring schemes

Four wiring schemes (A to D or E to H) are available for each application, depending on the type of measurement.

Table 9- 16 Wiring scheme of SM 336; F-AI 6 x 0/4 ... 20 mA HART

Wiring scheme	Measurement type	Channels
A	2-wire transducer, internal sensor supply	0 to 5
B	2-wire transducer, external sensor supply	0 to 5
C	4-wire transducer, internal sensor supply	0 to 5
D	4-wire transducer, external sensor supply	0 to 5
E	2-wire transducer, internal sensor supply with module redundancy	0 to 5, redundancy with 2 modules
F	2-wire transducer, external sensor supply with module redundancy	0 to 5, redundancy with 2 modules
G	4-wire transducer, internal sensor supply with module redundancy	0 to 5, redundancy with 2 modules
H	4-wire transducer, external sensor supply with module redundancy	0 to 5, redundancy with 2 modules

Wiring scheme A: 2-wire transducer, internal sensor supply

Particularity:

- Short circuit between sensor supply voltage V_{sn} and $Mn+$ is handled.
- It is possible to detect an undervoltage at the transducer by reading back the sensor supply in the module.

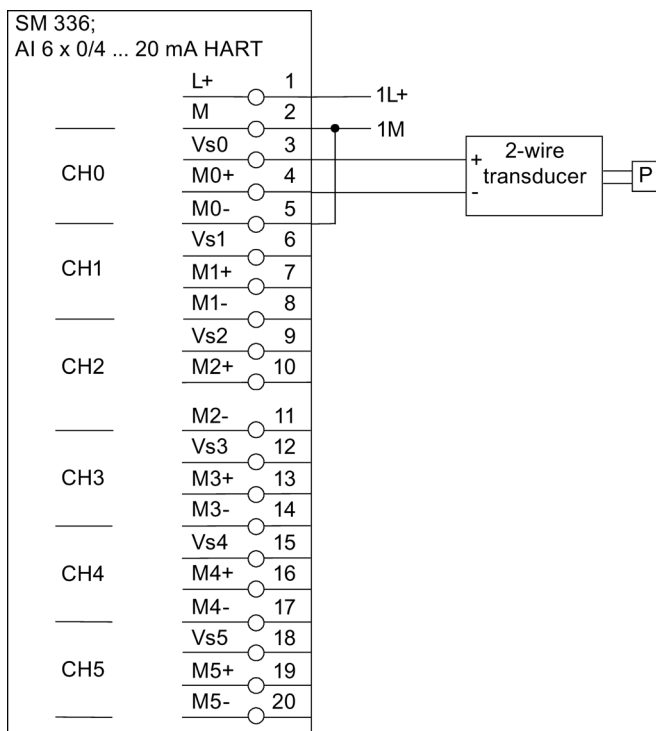

Figure 9-22 2-wire transducer, internal sensor supply

Wiring scheme B: 2-wire transducer, external sensor supply

Particularity:

⚠ WARNING

An undervoltage at the transducer cannot be detected, which means a transducer with undervoltage detection may be required.

Note

1L+ and 2L+ can be fed from one power supply. The maximum permissible common mode voltage U_{CM} must be observed.

⚠ WARNING

Depending on the internal structure of the sensor, a short circuit from 2L+ to Mn+ (sensor with measuring circuit referring to 2M) or from Mn- to 2M (sensor with measuring circuit referring to 2L+) can destroy the input resistors (see documentation for the utilized sensor). For this reason, a suitable measure must be taken to protect the input resistors (e.g. fuse on the module).

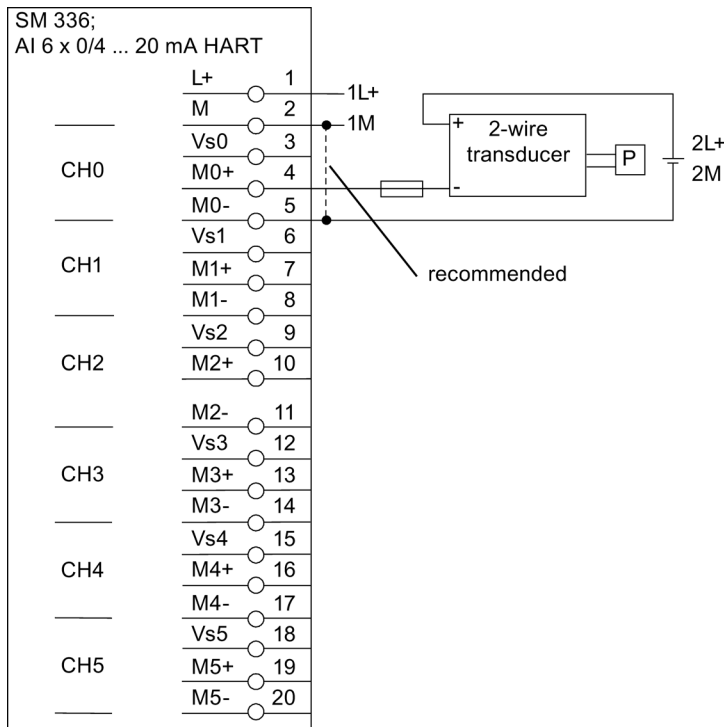

Figure 9-23 2-wire transducer, external sensor supply

Wiring scheme C: 4-wire transducer, internal sensor supply

Particularity:

- Short circuit between sensor supply voltage V_{sn} and $Mn+$ is handled.
- It is possible to detect an undervoltage at the transducer by reading back the sensor supply in the module.

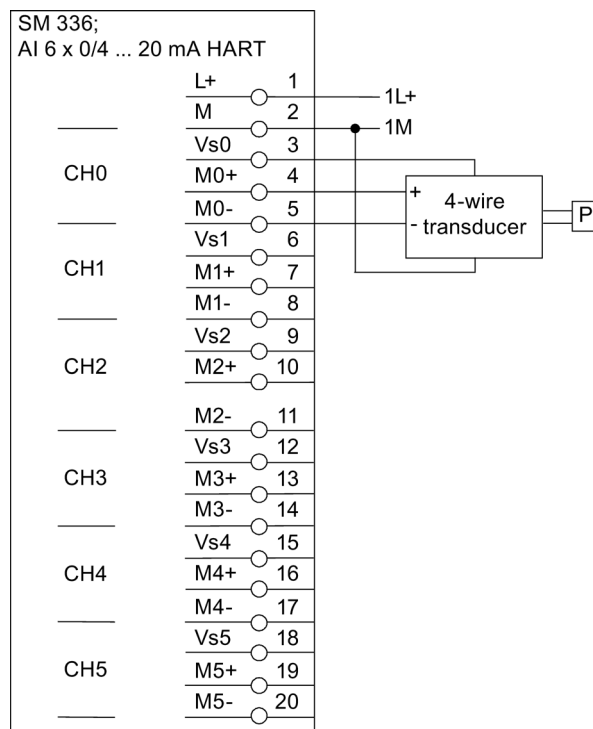

Figure 9-24 4-wire transducer, internal sensor supply

Wiring scheme D: 4-wire transducer, external sensor supply

Particularity:

⚠ WARNING

An undervoltage at the transducer cannot be detected, which means a transducer with undervoltage detection may be required.

Note

1L+ and 2L+ can be fed from one power supply. The maximum permissible common mode voltage U_{CM} must be observed.

⚠ WARNING

Depending on the internal structure of the sensor, a short circuit from 2L+ to Mn+ (sensor with measuring circuit referring to 2M) or from Mn- to 2M (sensor with measuring circuit referring to 2L+) can destroy the input resistors (see documentation for the utilized sensor). For this reason, a suitable measure must be taken to protect the input resistors (e.g. fuse on the module).

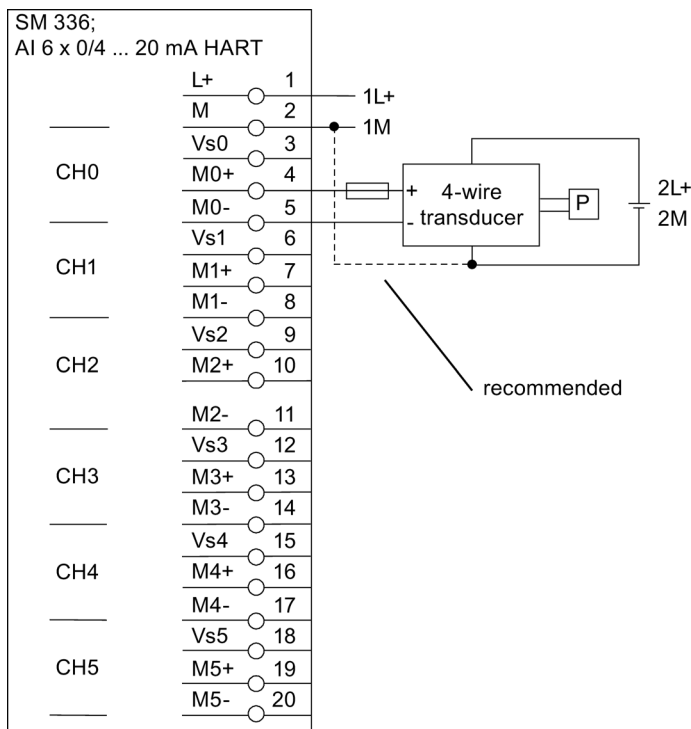

Figure 9-25 4-wire transducer, external sensor supply

Wiring scheme E: 2-wire transducer, internal sensor supply with module redundancy

Particularity:

- Short circuit between sensor supply voltage V_{sn} and $Mn+$ is handled.
- It is possible to detect an undervoltage at the transducer by reading back the sensor supply in the module.
- It is necessary to incorporate the external elements into the application-specific safety examination. This means appropriate external elements (e.g., Zener diodes) are needed to achieve the respective Safety Integrity Level.

Note

1L+ and 2L+ can be fed from one power supply.

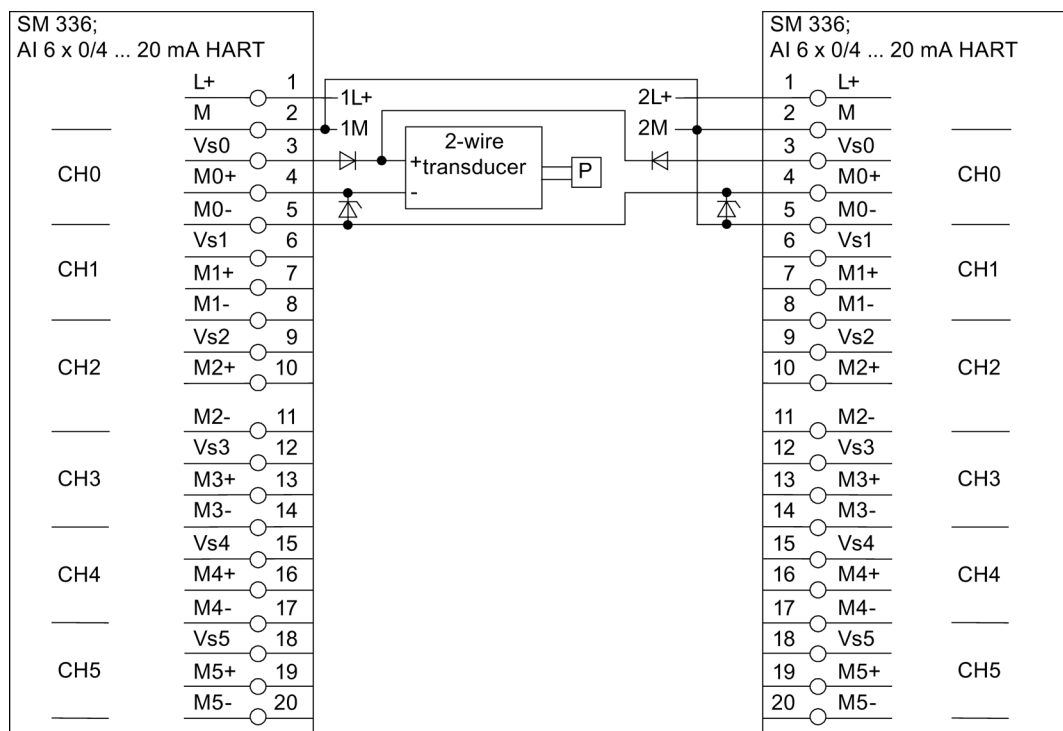

Figure 9-26 2-wire transducer, internal sensor supply with module redundancy

For information about the Zener diodes, refer to section "Calculation of the residual supply voltage at the transducer (Page 259)".

Wiring scheme F: 2-wire transducer, external sensor supply with module redundancy

Particularity:

 **WARNING**

An undervoltage at the transducer cannot be detected, which means a transducer with undervoltage detection may be required.

- It is necessary to incorporate the external elements into the application-specific safety examination. This means appropriate external elements (e.g., Zener diodes) are needed to achieve the respective Safety Integrity Level.

Note

1L+, 2L+, and 3L+ can be fed from one power supply. The maximum permissible common mode voltage U_{CM} must be observed.

 **WARNING**

Depending on the internal structure of the sensor, a short circuit from 2L+ to Mn+ (sensor with measuring circuit referring to 2M) or from Mn- to 2M (sensor with measuring circuit referring to 2L+) can destroy the input resistors (see documentation for the utilized sensor).

For this reason, a suitable measure must be taken to protect the input resistors (e.g. fuse on the module).

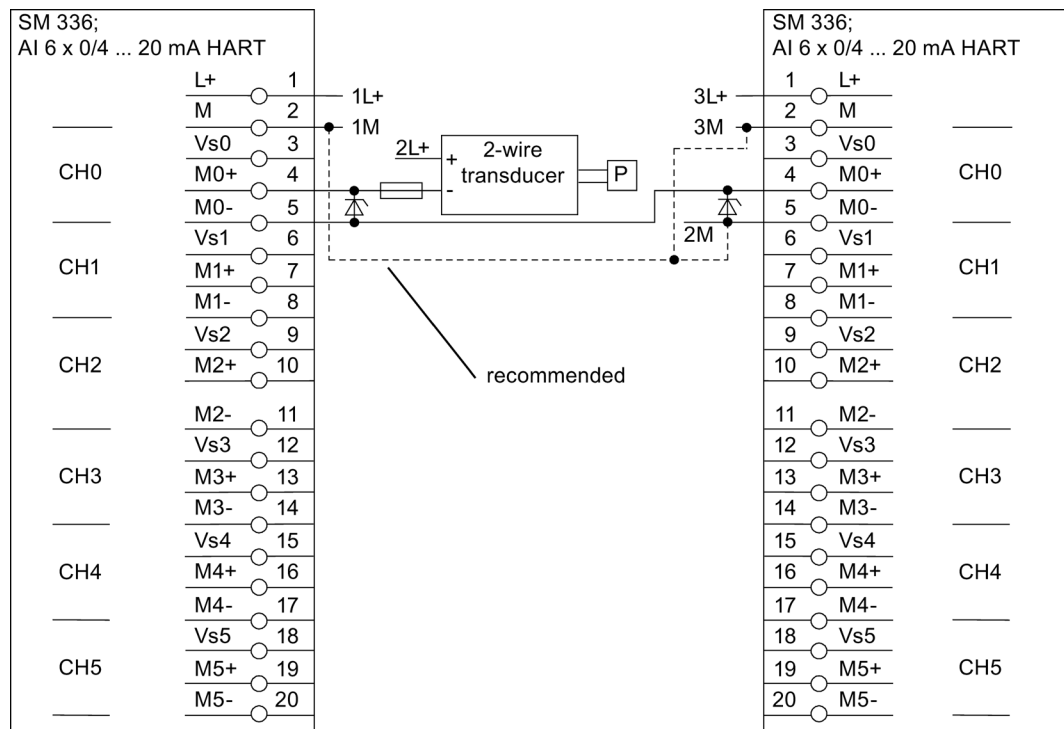

Figure 9-27 2-wire transducer, external sensor supply with module redundancy

For information about the Zener diodes, refer to section "Calculation of the residual supply voltage at the transducer (Page 259)".

Wiring scheme G: 4-wire transducer, internal sensor supply with module redundancy

Particularity:

- Short circuit between sensor supply voltage V_{sn} and M_{n+} is handled.
- It is possible to detect an undervoltage at the transducer by reading back the sensor supply in the module.
- It is necessary to incorporate the external elements into the application-specific safety examination. This means appropriate external elements (e.g., Zener diodes) are needed to achieve the respective Safety Integrity Level.

Note

1L+ and 2L+ can be fed from one power supply.

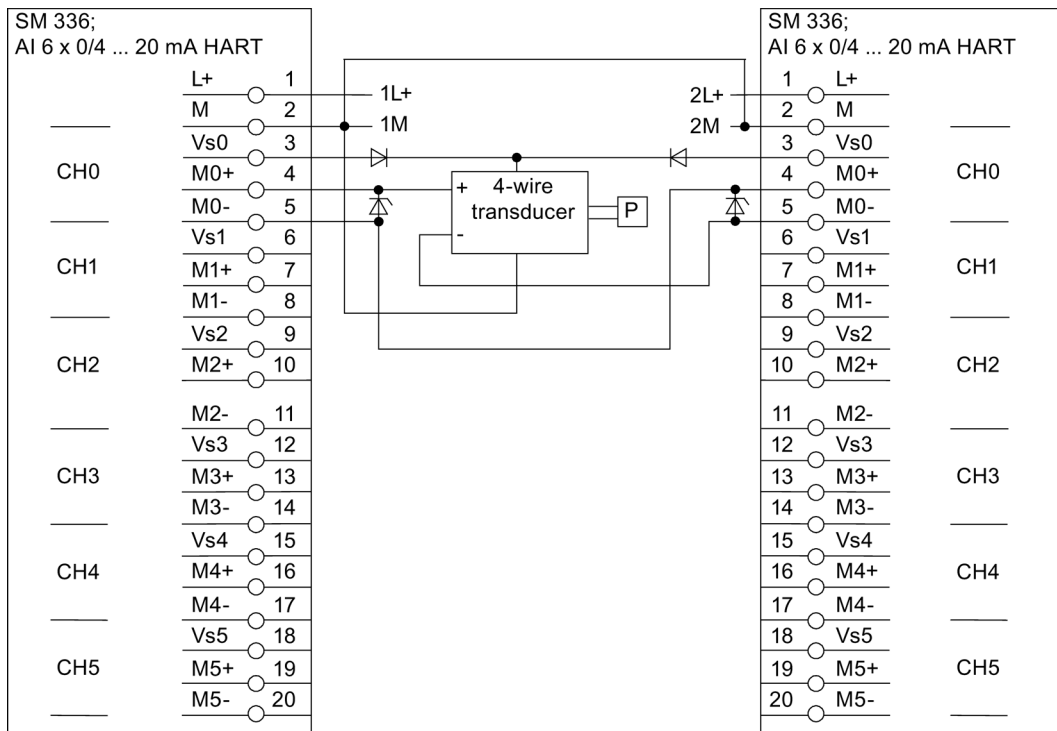

Figure 9-28 4-wire transducer, internal sensor supply with module redundancy

For information about the Zener diodes, refer to section "Calculation of the residual supply voltage at the transducer (Page 259)".

Wiring scheme H: 4-wire transducer, external sensor supply with module redundancy

WARNING

An undervoltage at the transducer cannot be detected, which means a transducer with undervoltage detection may be required.

- It is necessary to incorporate the external elements into the application-specific safety examination. This means appropriate external elements (e.g., Zener diodes) are needed to achieve the respective Safety Integrity Level.

Note

1L+, 2L+, and 3L+ can be fed from one power supply. The maximum permissible common mode voltage U_{CM} must be observed.

WARNING

Depending on the internal structure of the sensor, a short circuit from 2L+ to Mn+ (sensor with measuring circuit referring to 2M) or from Mn- to 2M (sensor with measuring circuit referring to 2L+) can destroy the input resistors (see documentation for the utilized sensor).

For this reason, a suitable measure must be taken to protect the input resistors (e.g. fuse on the module).

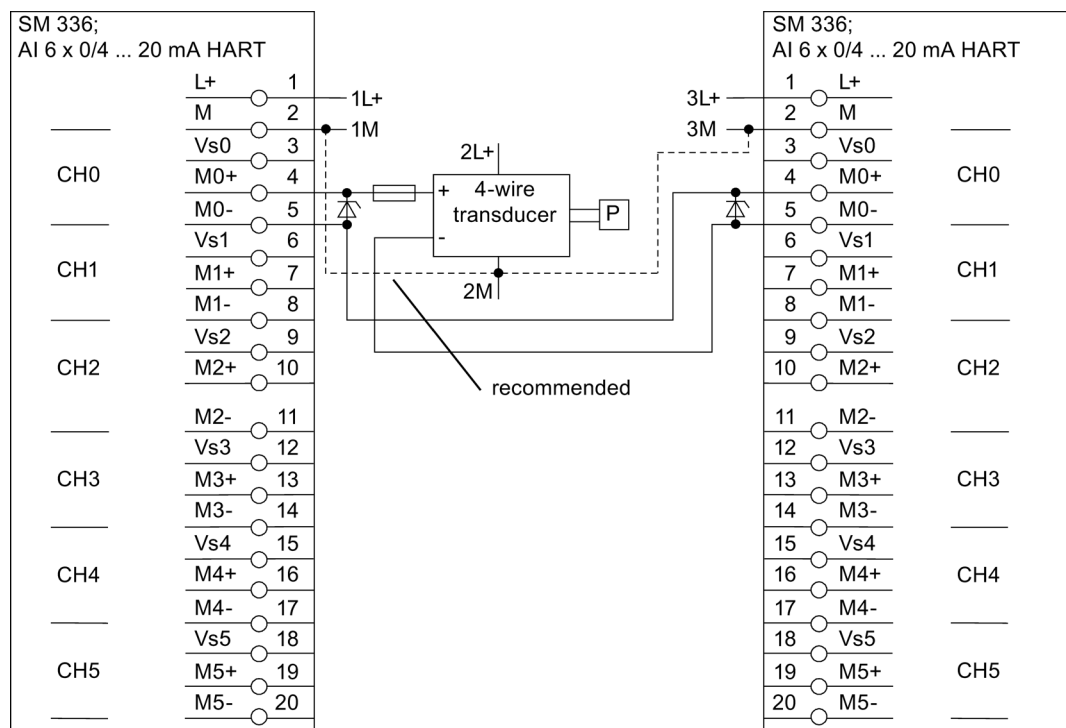

Figure 9-29 4-wire transducer, external sensor supply with module redundancy

For information about the Zener diodes, refer to section "Calculation of the residual supply voltage at the transducer (Page 259)".

9.3.4 Applications and wiring schemes

[ID: 8220065931]

Applications

The following applications are associated with the following wiring schemes:

Application		Wiring schemes							
		A	B	C	D	E	F	G	H
3:	1oo1 evaluation	X	X	X	X				
4:	1oo1 evaluation, transducer not redundant, high availability					X	X	X	X
5:	1oo2 evaluation	X	X	X	X				
	1oo2 evaluation, transducer via 1-channel	X	X	X	X				
6:	1oo2 evaluation, transducer via 1-channel, high-availability, transducer not redundant					X	X	X	X
7:	2oo3 evaluation, high-availability	X	X	X	X				
8:	2oo3 evaluation, high-availability, transducer not redundant					X	X	X	X
9:	2oo3 evaluation with 3 modules	X	X	X	X				

9.3.4.1 Calculation of the residual supply voltage at the transducer [ID: 8807638667]

Calculation of residual supply voltage

Determine the following voltages, according to your wiring scheme, for the purpose of calculating the residual supply voltage:

- Determine the minimum supply voltage (U_{V_min}):

Power supply, e.g., for SITOP 24 V $\pm 2\%$

$$U_{V_min} = U_V - |\text{Tolerance}| = 24 \text{ V} - 2\% = \mathbf{23.5 \text{ V}}$$

(neglecting the voltage drop at the supply line to the module)

- Calculate the maximum voltage drop at the signal line (U_{line}):

e.g. for copper line 500 m with $\varnothing = 0.5 \text{ mm}^2$; with $I_{max} = 25 \text{ mA}$

$$R_{Line} = \frac{500 \text{ m}}{0.5 \text{ mm}^2 \times 56 \text{ m}/(\text{mm}^2\Omega)} \times 2 = 35.7 \Omega$$

$$U_{Line} = 35.7 \Omega \times 25 \text{ mA} = \mathbf{0.9 \text{ V}}$$

- Calculate the voltage drop at the input resistance (U_{Ri}) of the module:

– With $R_{i_max} = 175 \Omega$; with $I_{max} = 25 \text{ mA}$

$$U_{Ri} = 175 \Omega \times 25 \text{ mA} = \mathbf{4.4 \text{ V}}$$

– When Zener diodes are used in a high-availability application, this higher voltage shall be used, taking into account the tolerances.

e.g., when using Zener diodes with 5.6 V and 6.2 V:

$$U_{Z_5V6} = U_Z + \text{Tolerance} = 5.6 \text{ V} + 5\% = \mathbf{5.9 \text{ V}}$$

$$U_{Z_6V2} = U_Z + \text{Tolerance} = 6.2 \text{ V} + 5\% = \mathbf{6.5 \text{ V}}$$

- Determine the voltage drop at the sensor supply:

$$U_{SensorSupply} = \mathbf{0.5 \text{ V}}$$

- Determine the voltage drop (U_{Diode}) at the longitudinal diode for disconnection of the sensor supply:

e.g., for BYV27-100

– For 2-wire transducer, with $I_{max} = 25 \text{ mA}$

$$U_{Diode} = \mathbf{\text{approx. } 0.7 \text{ V}}$$

– For 4-wire transducer, with $I_{max} = 300 \text{ mA}$

$$U_{Diode} = \mathbf{\text{approx. } 0.9 \text{ V}}$$

Subtract the voltage drop for the line at the internal resistance and at the diodes from the minimum supply voltage. Proceed according to the wiring scheme for your sensor.

Example for calculating the residual supply voltage in application 3:

Minimum residual voltage (U_{\min}) on a 2-wire transducer, non-high-availability application:

$$U_{\min} = U_{V_{\min}} - U_{\text{line}} - U_{Ri} - U_{\text{SensorSupply}}$$

$$U_{\min} = 23.5 \text{ V} - 0.9 \text{ V} - 4.4 \text{ V} - 0.5 \text{ V} = \mathbf{17.7 \text{ V}}$$

Example for calculating the residual supply voltage in application 4:

- Minimum residual voltage (U_{\min}) on a 2-wire transducer, high-availability application:

$$U_{\min} = U_{V_{\min}} - U_{\text{Line}} - U_{\text{Diode}} - U_{Z_{6V2}} - U_{Ri} - U_{\text{SensorSupply}}$$

$$U_{\min} = 23.5 \text{ V} - 0.9 \text{ V} - 0.7 \text{ V} - 6.5 \text{ V} - 4.4 \text{ V} - 0.5 \text{ V} = \mathbf{10.5 \text{ V}}$$

- Maximum voltage drop (U_{Line}) on the supply line of a 4-wire transducer:

e.g. for copper line 500 m with $\varnothing = 1.5 \text{ mm}^2$; with $I_{\max} = 300 \text{ mA}$

$$R_{\text{Line}} = \frac{500 \text{ m}}{1.5 \text{ mm}^2 \times 56 \text{ m}/(\text{mm}^2\Omega)} \times 2 = 11.9 \Omega$$

$$U_{\text{Line}} = 11.9 \Omega \times 300 \text{ mA} = 3.6 \text{ V}$$

Minimum supply voltage (U_{\min}) on a 4-wire transducer, high-availability application:

$$U_{\min} = U_{V_{\min}} - U_{\text{line}} - U_{\text{Diode}} - U_{\text{SensorSupply}}$$

$$U_{\min} = 23.5 \text{ V} - 3.6 \text{ V} - 0.9 \text{ V} - 0.5 \text{ V} = \mathbf{18.5 \text{ V}}$$

Determination of maximum load voltage

$$U_{\text{LoadSensor}} > U_{\text{LoadModule}}$$

Load voltage for sensor

$$U_{\text{LoadSensor}} = I_{\text{max}} \times R_{\text{Load}}$$

Load voltage for the module in 4-wire transducer, high-availability application

$$U_{\text{LoadModule}} = U_{\text{Ri}} + U_{\text{Line}} + U_{\text{Z}_6\text{V2}}$$

⚠ WARNING

The fail-safe performance characteristics of the external components (e.g., transducer, diodes, Zener diodes) are not included in the fail-safe performance characteristics of the module (see technical data of the module). These must be determined and/or taken into account in a safety examination.

⚠ WARNING

You must take the following into consideration when selecting Zener diodes for high-availability interconnection of the analog module:

Taking into account the tolerances, the wire break voltage must be greater than the maximum voltage drop on the input resistance of the module. In particular, the residual current must be considered since it affects the measurement result.

For safety reasons, we recommend the use of a variety (diversity) of Zener diodes (common cause error).

For example, you could use the following Zener diodes: 5.6 V (1N4734A) and 6.2 V (1N4735A), or use MTA 6ES7650-1AH51-5XX0 with 6ES7650-1BB51-0XX0 and 6ES7650-1BC51-0XX0 (see Manual " Marshalled Termination Assemblies ET 200M Remote I/O Modules (<http://support.automation.siemens.com/WW/view/en/22091986>) ").

9.3.5 Applications 1 and 2 [ID: 8219928331]**Applications 1 and 2**

Applications 1 and 2 are omitted because the module supports only safety mode.

9.3.6 Application 3: Safety mode SIL3/Cat.3/PLe [ID: 8220519819]

Introduction

Below are the wiring scheme and the parameter assignment of SM 336; F-AI 6 x 0/4 ... 20 mA HART for

- Application 3: Safety mode SIL3/Cat.3/PLe for "1oo1 evaluation.

Diagnostic messages, possible causes of the problem and their corrective measures are found in tables *Diagnostic messages of SM 336; F-AI 6 x 0/4 ... 20 mA HART* and *Diagnostic messages and associated corrective measures for SM 336; F-AI 6 x 0/4 ... 20 mA HART* in chapter "Diagnostic messages of SM 336; F-AI 6 x 0/4 ... 20 mA HART (Page 281)".

Current measurement 0/4 to 20 mA with 2-wire and 4-wire transducer for application 3

Six process signals can be connected to a module in this interconnection variant. Sensor supply V_{sn} is provided by the module for 6 channels. The sensors can also be connected to an external sensor supply (see Figure *External sensor supply, 2-wire transducer for SM 336; F-AI 6 x 0/4 ... 20 mA HART* in Chapter "Properties, front view, wiring diagram and block diagram (Page 241)").

You can use interconnection schemes A to D for this application.

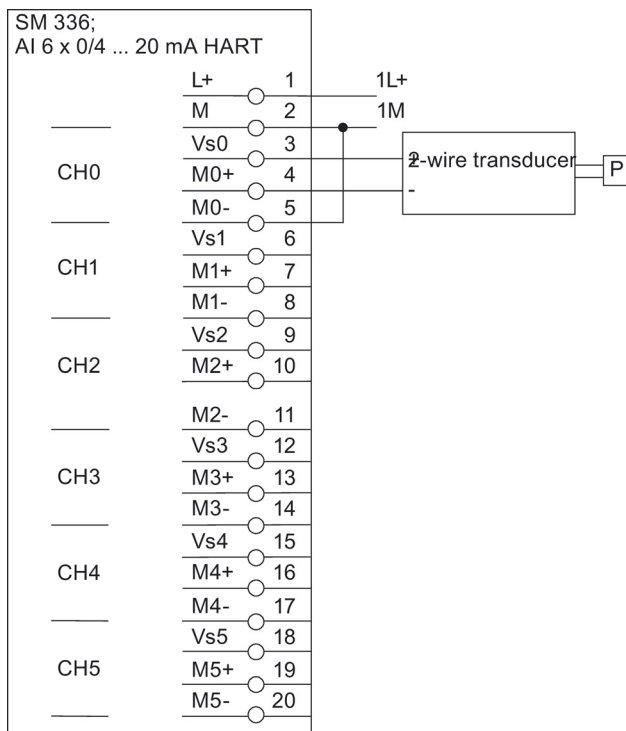



Figure 9-30 1oo1 evaluation

 WARNING
To achieve SIL3/Cat.3/PLe using this wiring, you must use a suitably qualified sensor.

Assignable parameters for application 3

Table 9- 17 Parameters for application 3 of SM 336; F-AI 6 x 0/4 ... 20 mA HART

Parameters	Range of values in safety mode	Type	Effective range
Diagnostic interrupt	Activated/deactivated	Static	Module
Behavior after channel faults	Passivate the entire module/Passivate the channel	Static	Module
HART_Gate	Off/On/Can be switched	Static	Module
Interference frequency suppression	50 Hz/60 Hz	Static	Module
Evaluation of the sensors	1oo1 evaluation	Static	Channel
Measuring range	4 to 20 mA, 0 to 20 mA	Static	Channel
F-wire break detection	activated/deactivated (in the 4 to 20 mA measuring range)	Static	Channel
Smoothing	1 / 4 / 16 / 64 conversion cycles	Static	Channel
HART function	Activated/deactivated	Static	Channel
HART repetitions	0 to 255	Static	Channel
HART group diagnostics	Activated/deactivated	Static	Channel

9.3.7 Application 4: Safety mode SIL3/Cat.3/PLe with high availability (in S7 F/FH Systems only) [ID: 8220930187]

Introduction

Below are the wiring scheme and the parameter assignment of SM 336; F-AI 6 x 0/4 ... 20 mA HART for

- Application 4: Safety mode SIL3/Cat.3/PLe for "1oo1 evaluation with high availability.

Diagnostic messages, possible causes of the problem and their corrective measures are found in tables *Diagnostic messages of SM 336; F-AI 6 x 0/4 ... 20 mA HART* and *Diagnostic messages and associated corrective measures for SM 336; F-AI 6 x 0/4 ... 20 mA HART* in chapter "Diagnostic messages of SM 336; F-AI 6 x 0/4 ... 20 mA HART (Page 281)".

Current measurement 0/4 to 20 mA with 2-wire and 4-wire transducer, transducer not redundant, for application 4

Six process signals can be connected to two redundant modules in this interconnection variant. One sensor is connected via one channel to the two modules for each process signal. Sensor supply V_{sn} is provided by the module for 6 channels. The sensors can also be connected to an external sensor supply (see Figure *External sensor supply, 2-wire transducer for SM 336; F-AI 6 x 0/4 ... 20 mA HART* in chapter "Properties, front view, wiring diagram and block diagram (Page 241)").

You can use interconnection schemes E to H for this application.

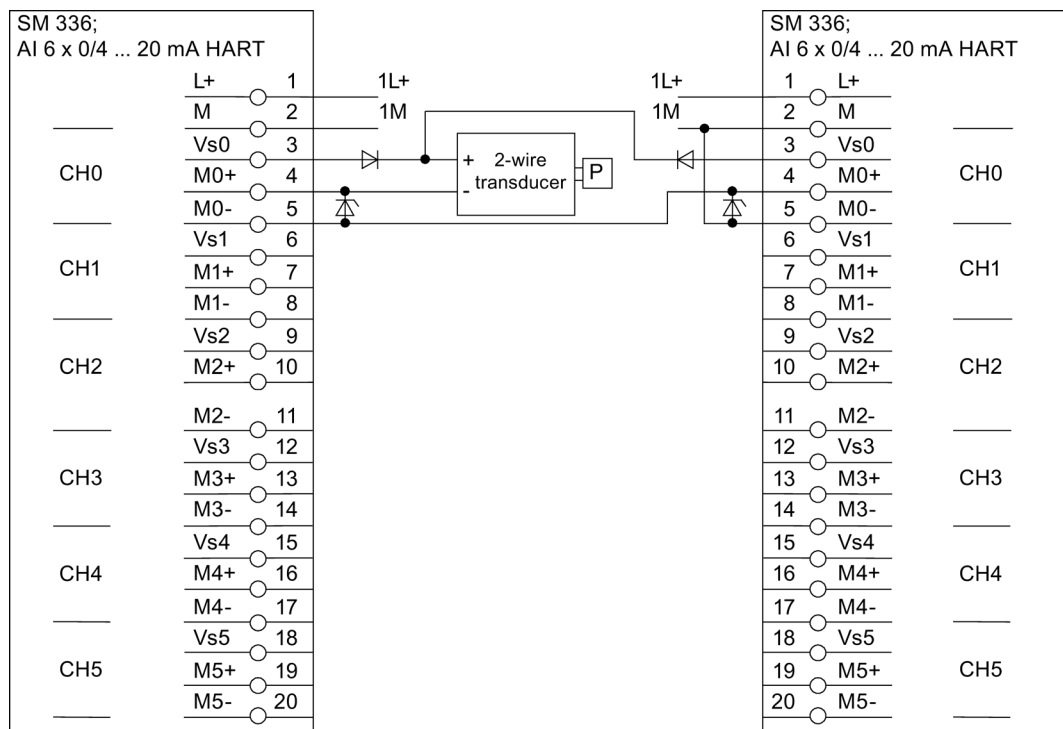

Figure 9-31 1oo1 evaluation, redundant F-SMs, single-channel transducer

For information about the Zener diodes, refer to chapter "Calculation of the residual supply voltage at the transducer (Page 259)".

WARNING

To achieve SIL3/Cat.4/PLe using this wiring, you must use a suitably qualified sensor.

Note

You can supply the two F-SMs from two power supply units. If you use two power supply units, the two grounds on the F-SMs will have to be connected with each other.

Assignable parameters for application 4

Table 9- 18 Parameters for application 4 of SM 336; F-AI 6 x 0/4 ... 20 mA HART

Parameters	Range of values in safety mode	Type	Effective range
Diagnostic interrupt	Activated/deactivated	Static	Module
Behavior after channel fault	Passivate the entire module/Passivate the channel	Static	Module
HART_Gate	Off/On/Can be switched	Static	Module
Interference frequency suppression	50 Hz/60 Hz	Static	Module
Evaluation of the sensors	1oo1 evaluation	Static	Channel
Measuring range	4 to 20 mA, 0 to 20 mA	Static	Channel
F-wire break detection	activated/deactivated (in the 4 to 20 mA measuring range)	Static	Channel
Smoothing	1 / 4 / 16 / 64 conversion cycles	Static	Channel
HART function	Activated/deactivated	Static	Channel
HART repetitions	0 to 255	Static	Channel
HART group diagnostics	Activated/deactivated	Static	Channel
Redundancy	Activated/deactivated	Static	Channel

9.3.8 Application 5: Safety mode SIL3/Cat.4/PLe [ID: 8221136523]

Introduction

Below are the wiring schemes and the parameter assignment of SM 336; F-AI 6 x 0/4 ... 20 mA HART for

- Application 5: Safety mode SIL3/Cat.4/PLe for "1oo2 evaluation.

Diagnostic messages, possible causes of the problem and their corrective measures are found in tables *Diagnostic messages of SM 336; F-AI 6 x 0/4 ... 20 mA HART* and *Diagnostic messages and associated corrective measures for SM 336; F-AI 6 x 0/4 ... 20 mA HART* in chapter "Diagnostic messages of SM 336; F-AI 6 x 0/4 ... 20 mA HART (Page 281)".

Current measurement 0/4 to 20 mA with 2-wire and 4-wire transducer for application 5

Three process signals can be connected to a module in this interconnection variant. Sensor supply V_{sn} is provided by the module for 3 channels. The sensors can also be connected to an external sensor supply (see Figure *External sensor supply, 2-wire transducer for SM 336; F-AI 6 x 0/4 ... 20 mA HART* in Chapter "Properties, front view, wiring diagram and block diagram (Page 241)").

You can use interconnection schemes A to D for this application.

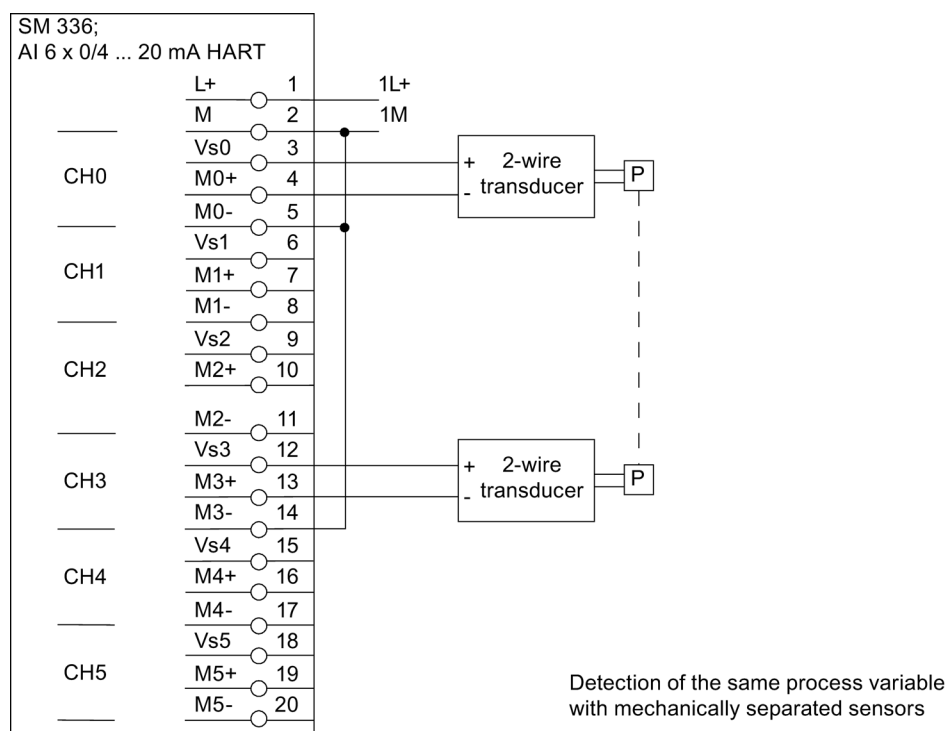

Figure 9-32 1oo2 evaluation, dual-channel transducer

WARNING

To achieve SIL3/Cat.4/PLe using this wiring, you must use a suitably qualified sensor.

Current measurement 0/4 to 20 mA with 2-wire and 4-wire transducer, transducer via one channel, for application 5

Three process signals can be connected to a module in this interconnection variant. Sensor supply V_{sn} is provided by the module for 3 channels. The sensors can also be connected to an external sensor supply (see Figure *External sensor supply, 4-wire transducer for SM 336; F-AI 6 x 0/4 ... 20 mA HART* in Chapter " Properties, front view, wiring diagram and block diagram (Page 241) ").

Interconnection types A to D can be used for this application.

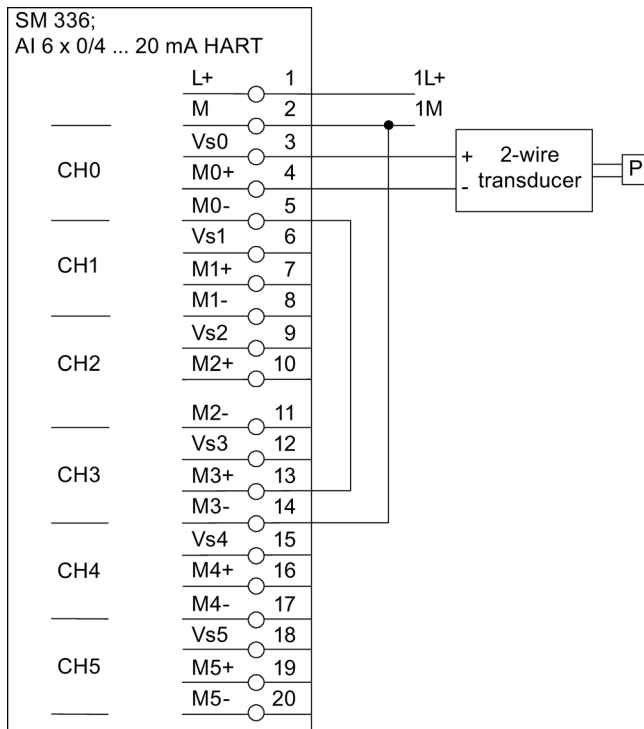

Figure 9-33 1oo2 evaluation, single-channel transducer

⚠ WARNING

To achieve SIL3/Cat.4/PLe using this wiring, you must use a suitably qualified sensor.

Note

If you are using *SIMATIC PDM* as the engineering tool for your HART field device, create a HART field device only for the channel with the lower channel number.

Assignable parameters for application 5

Table 9- 19 Parameters for application 5 of SM 336; F-AI 6 x 0/4 ... 20 mA HART

Parameters	Range of values in safety mode	Type	Effective range
Diagnostic interrupt	Activated/deactivated	Static	Module
Behavior after channel fault	Passivate the entire module/Passivate the channel	Static	Module
HART_Gate	Off/On/Can be switched	Static	Module
Interference frequency suppression	50 Hz/60 Hz	Static	Module
Evaluation of the sensors	1oo2 evaluation*	Static	Channel
Measuring range	4 to 20 mA, 0 to 20 mA	Static	Channel
F-wire break detection	activated/deactivated (in the 4 to 20 mA measuring range)	Static	Channel
Smoothing	1 / 4 / 16 / 64 conversion cycles	Static	Channel
Discrepancy time (ms)	0 to 30000	Static	Channel
Tolerance window (%) absolute	0.2 to 20	Static	Channel
Tolerance window (%) relative	0.2 to 20	Static	Channel
Standard value	MAX/MIN	Static	Channel
HART function	Activated/deactivated	Static	Channel
HART repetitions	0 to 255	Static	Channel
HART group diagnostics	Activated/deactivated	Static	Channel
* If you are evaluating sensors in your safety program (e.g., in <i>S7 F Systems</i> using F-block F_1oo2AI), configure "1oo1 evaluation".			

Discrepancy analysis for fail-safe analog input modules

If you have configured 1oo2 evaluation, you can configure a discrepancy time and an absolute and a relative tolerance window for each channel pair of the module. In addition, configure the standard value (MIN = lower value / MAX = higher value) to be applied and transferred to the F-CPU.

If the difference between the two redundant input channels of the channel pair exists longer than the configured discrepancy time, an error is signaled and the fail-safe value (7FFF_H) is transferred. In *S7 Distributed Safety*, the fail-safe value 0 is provided in the PII for the safety program in place of 7FFF_H. In *S7 F/FH Systems* the fail-safe value assigned at the input SUBS_V of the channel driver will be provided in the PII.

9.3.9 Application 6: Safety mode SIL3/Cat.4/PLe with high availability (in S7 F/FH Systems only) [ID: 8221877003]

Introduction

Below are the wiring scheme and the parameter assignment of SM 336; F-AI 6 x 0/4 ... 20 mA HART for

- Application 6: Safety mode SIL3/Cat.4/PLe for "1oo2 evaluation with high availability.

Diagnostic messages, possible causes of the problem and their corrective measures are found in tables *Diagnostic messages of SM 336; F-AI 6 x 0/4 ... 20 mA HART* and *Diagnostic messages and associated corrective measures for SM 336; F-AI 6 x 0/4 ... 20 mA HART* in chapter "Diagnostic messages of SM 336; F-AI 6 x 0/4 ... 20 mA HART (Page 281)".

Current measurement 0/4 to 20 mA with 2-wire and 4-wire transducer for application 6, transducer not redundant

Three process signals can be connected to two redundant modules in this interconnection variant. Two redundant sensors are required for each process signal. Two sensors are connected to two channels of each module (1oo2 evaluation). Sensor supply V_{sn} is provided by the module for 3 channels. The sensors can also be connected to an external sensor supply (see Figure *External sensor supply, 4-wire transducer for SM 336; F-AI 6 x 0/4 ... 20 mA HART* in Chapter "Properties, front view, wiring diagram and block diagram (Page 241)").

You can use interconnection schemes E to H for this application.

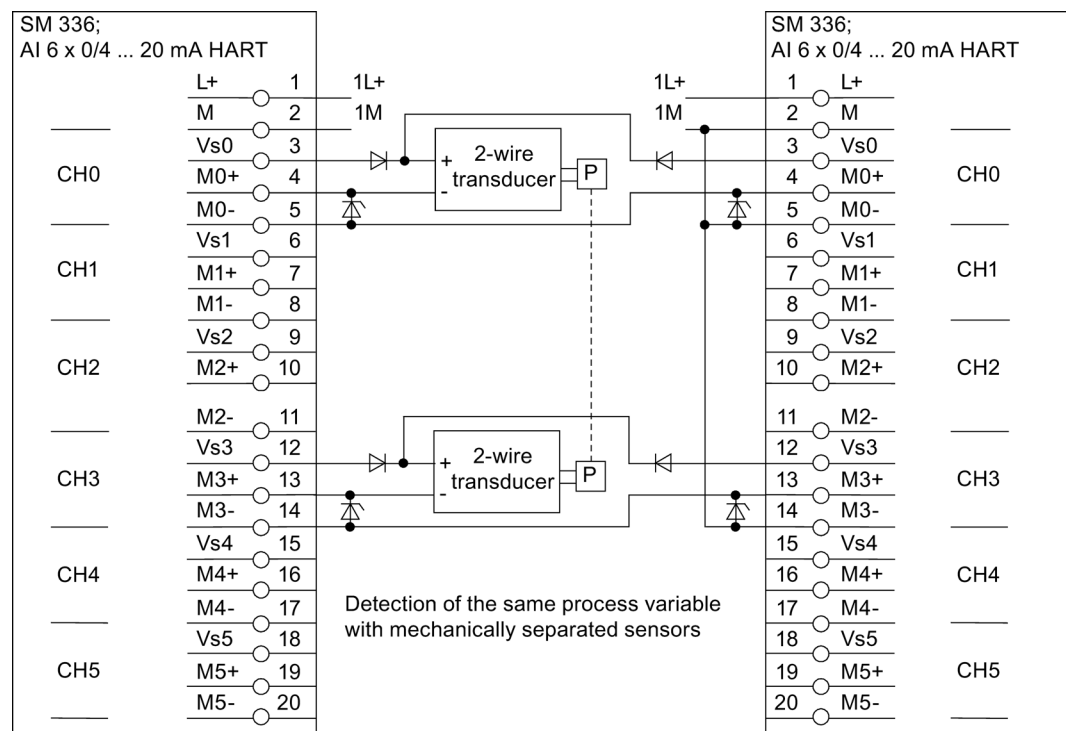

Figure 9-34 1oo2 evaluation, redundant F-SMs, dual-channel transducer

For information about the Zener diodes, refer to chapter "Calculation of the residual supply voltage at the transducer (Page 259)".

WARNING

To achieve SIL3/Cat.4/PLe using this wiring, you must use a suitably qualified sensor.

Note

You can supply the two F-SMs from two power supply units. If you use two power supply units, the two grounds on the F-SMs will have to be connected with each other.

Assignable parameters for application 6

Table 9- 20 Parameters for application 6 of SM 336; F-AI 6 x 0/4 ... 20 mA HART

Parameters	Range of values in safety mode	Type	Effective range
Diagnostic interrupt	Activated/deactivated	Static	Module
Behavior after channel fault	Passivate the entire module/Passivate the channel	Static	Module
HART_Gate	Off/On/Can be switched	Static	Module
Interference frequency suppression	50 Hz/60 Hz	Static	Module
Evaluation of the sensors	1oo2 evaluation*	Static	Channel
Measuring range	4 to 20 mA, 0 to 20 mA	Static	Channel
F-wire break detection	activated/deactivated (in the 4 to 20 mA measuring range)	Static	Channel
Smoothing	1 / 4 / 16 / 64 conversion cycles	Static	Channel
Discrepancy time (ms)	0 to 30000	Static	Channel
Tolerance window (%) absolute	0.2 to 20	Static	Channel
Tolerance window (%) relative	0.2 to 20	Static	Channel
Standard value	MAX/MIN	Static	Channel
HART function	Activated/deactivated	Static	Channel
HART repetitions	0 to 255	Static	Channel
HART group diagnostics	Activated/deactivated	Static	Channel
Redundancy	Activated/deactivated	Static	Channel
* If you are evaluating sensors in your safety program (e.g., in <i>S7 F Systems</i> using F-block F_1oo2AI), configure "1oo1 evaluation".			

Discrepancy analysis for fail-safe analog input modules

If you have configured 1oo2 evaluation, you can configure a discrepancy time and an absolute and a relative tolerance window for each channel pair of the module. In addition, configure the standard value (MIN = lower value / MAX = higher value) to be applied and transferred to the F-CPU.

If the difference between the two redundant input channels of the channel pair exists longer than the configured discrepancy time, an error is signaled and the fail-safe value (7FFF_H) is transferred. In *S7 Distributed Safety*, the fail-safe value 0 is provided in the PII for the safety program in place of 7FFF_H. In *S7 F/FH Systems* the fail-safe value assigned at the input SUBS_V of the channel driver will be provided in the PII.

9.3.10 Application 7: Safety mode SIL3/Cat.4/PLe [ID: 8222323595]

Introduction

Below are the wiring scheme and the parameter assignment of SM 336; F-AI 6 x 0/4 ... 20 mA HART for

- Application 7: Safety mode SIL3/Cat.4/PLe for "2oo3 evaluation with high availability.

Diagnostic messages, possible causes of the problem and their corrective measures are found in tables *Diagnostic messages of SM 336; F-AI 6 x 0/4 ... 20 mA HART* and *Diagnostic messages and associated corrective measures for SM 336; F-AI 6 x 0/4 ... 20 mA HART* in chapter "Diagnostic messages of SM 336; F-AI 6 x 0/4 ... 20 mA HART (Page 281)".

Current measurement 0/4 to 20 mA with 2-wire and 4-wire transducer, high-availability, for application 7

Two process signals can be connected to a module in this interconnection variant. The sensors can also be connected to an external sensor supply (see Figure *External sensor supply, 2-wire transducer for SM 336; F-AI 6 x 0/4 ... 20 mA HART* in chapter "Properties, front view, wiring diagram and block diagram (Page 241)").

You can use interconnection schemes A to D for this application.

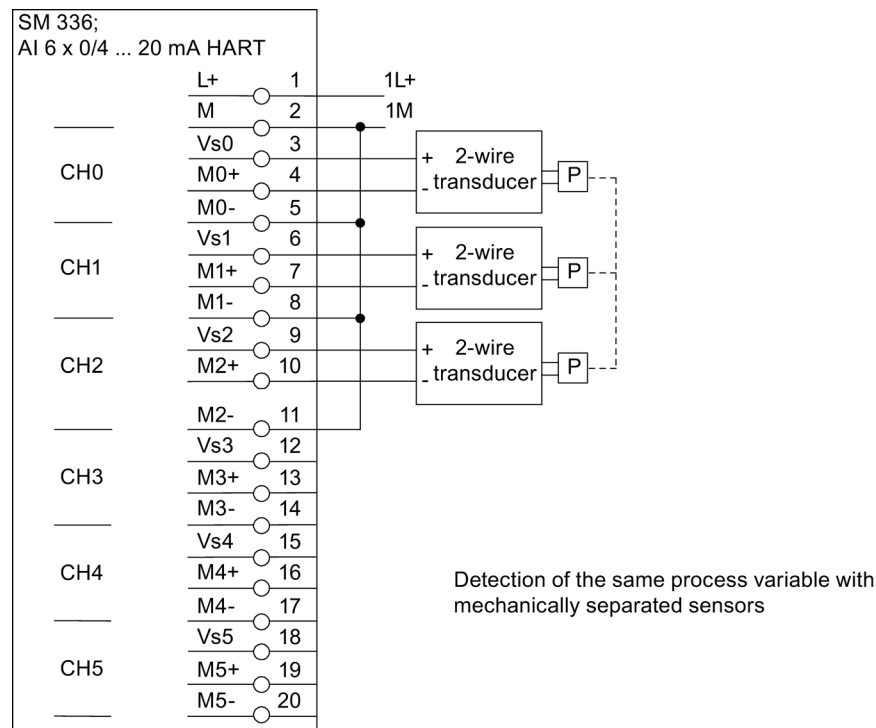

Figure 9-35 2oo3 evaluation

 **WARNING**

To achieve SIL3/Cat.4/PLe using this wiring, you must use a suitably qualified sensor.

Note

If you are using *SIMATIC PDM* as the engineering tool for your HART field device, create a HART field device only for the channel with the lower channel number.

Assignable parameters for application 7

Table 9- 21 Parameters for application 7 of SM 336; F-AI 6 x 0/4 ... 20 mA HART

Parameters	Range of values in safety mode	Type	Effective range
Diagnostic interrupt	Activated/deactivated	Static	Module
Behavior after channel fault	Passivate the entire module/Passivate the channel	Static	Module
HART_Gate	Off/On/Can be switched	Static	Module
Interference frequency suppression	50 Hz/60 Hz	Static	Module
Evaluation of the sensors	1oo1 evaluation	Static	Channel
Measuring range	4 to 20 mA, 0 to 20 mA	Static	Channel
F-wire break detection	activated/deactivated (in the 4 to 20 mA measuring range)	Static	Channel
Smoothing	1 / 4 / 16 / 64 conversion cycles	Static	Channel
HART function	Activated/deactivated	Static	Channel
HART repetitions	0 to 255	Static	Channel
HART group diagnostics	Activated/deactivated	Static	Channel

Discrepancy analysis for fail-safe analog input modules

For safety-oriented applications according to SIL 3, perform a discrepancy analysis with 2oo3 evaluation in your safety program (e.g. in *S7 F/FH Systems* with the F_2oo3_AI F-block).

9.3.11 Application 8: Safety mode SIL3/Cat.4/PLe with high availability (in S7 F/FH Systems only) [ID: 8223768715]

Introduction

Below are the wiring scheme and the parameter assignment of SM 336; F-AI 6 x 0/4 ... 20 mA HART for

- Application 8: Safety mode SIL3/Cat.4/PLe for "2oo3 evaluation with high availability.

Diagnostic messages, possible causes of the problem and their corrective measures are found in tables *Diagnostic messages of SM 336; F-AI 6 x 0/4 ... 20 mA HART* and *Diagnostic messages and associated corrective measures for SM 336; F-AI 6 x 0/4 ... 20 mA HART* in chapter "Diagnostic messages of SM 336; F-AI 6 x 0/4 ... 20 mA HART (Page 281)".

Current measurement 0/4 to 20 mA with 2-wire and 4-wire transducer, transducer not redundant, for application 8

Two process signals can be connected to two redundant modules in this interconnection variant. Three sensors are connected to each module (2oo3 evaluation). Sensor supply V_{sn} is provided by the module for 3 channels. The sensors can also be connected to an external sensor supply (see Figure *External sensor supply, 4-wire transducer for SM 336; F-AI 6 x 0/4 ... 20 mA HART* in Chapter "Properties, front view, wiring diagram and block diagram (Page 241)").

You can use interconnection schemes E to H for this application.

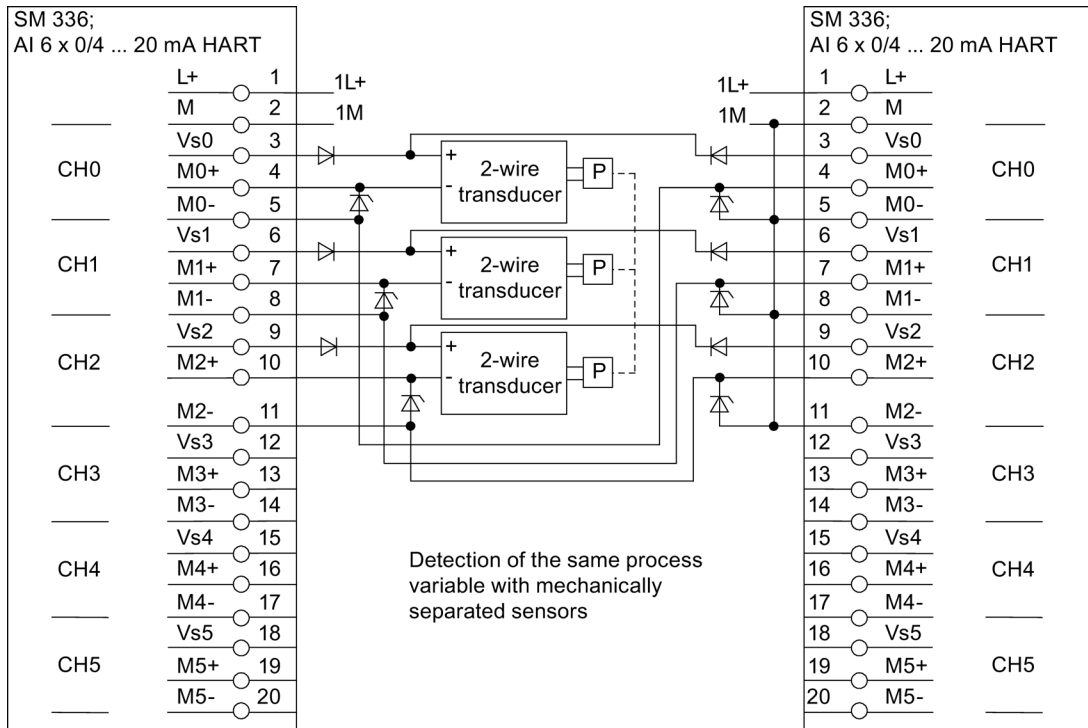

Figure 9-36 2oo3 evaluation, redundant F-SMs, three-channel transducer

For information about the Zener diodes, refer to chapter "Calculation of the residual supply voltage at the transducer (Page 259)".

⚠ WARNING
 To achieve SIL3/Cat.4/PLe using this wiring, you must use a suitably qualified sensor.

Note

If you are using *SIMATIC PDM* as the engineering tool for your HART field device, create a HART field device only for the channel with the lower channel number.

Note

You can supply the two F-SMs from two power supply units. If you use two power supply units, the two grounds on the F-SMs will have to be connected with each other.

Assignable parameters for application 8

Table 9- 22 Parameters for application 8 of SM 336; F-AI 6 x 0/4 ... 20 mA HART

Parameters	Range of values in safety mode	Type	Effective range
Diagnostic interrupt	Activated/deactivated	Static	Module
Behavior after channel fault	Passivate the entire module/Passivate the channel	Static	Module
HART_Gate	Off/On/Can be switched	Static	Module
Interference frequency suppression	50 Hz/60 Hz	Static	Module
Evaluation of the sensors	1oo1 evaluation	Static	Channel
Measuring range	4 to 20 mA, 0 to 20 mA	Static	Channel
F-wire break detection	activated/deactivated (in the 4 to 20 mA measuring range)	Static	Channel
Smoothing	1 / 4 / 16 / 64 conversion cycles	Static	Channel
HART function	Activated/deactivated	Static	Channel
HART repetitions	0 to 255	Static	Channel
HART group diagnostics	Activated/deactivated	Static	Channel
Redundancy	Activated/deactivated	Static	Channel

Discrepancy analysis for fail-safe analog input modules

For safety-oriented applications according to SIL 3, perform a discrepancy analysis with 2oo3 evaluation in your safety program (e.g. in *S7 F/FH Systems* with the F_2oo3_AI F-block).

9.3.12 Application 9: Safety mode SIL3/Cat.4/PLe with three modules and high availability (in S7 F/FH Systems only) [ID: 8224496267]

Introduction

Below are the wiring scheme and the parameter assignment of SM 336; F-AI 6 x 0/4 ... 20 mA HART for

- Application 9: Safety mode SIL3/Cat.4/PLe for "2oo3 evaluation with high availability.

Diagnostic messages, possible causes of the problem and their corrective measures are found in tables *Diagnostic messages of SM 336; F-AI 6 x 0/4 ... 20 mA HART* and *Diagnostic messages and associated corrective measures for SM 336; F-AI 6 x 0/4 ... 20 mA HART* in chapter "Diagnostic messages of SM 336; F-AI 6 x 0/4 ... 20 mA HART (Page 281)".

Current measurement 0/4 to 20 mA with 2-wire and 4-wire transducer for application 9

Six process signals can be connected to three redundant modules in this interconnection variant. Sensor supply V_{sn} is provided by the module for 6 channels. The sensors can also be connected to an external sensor supply (see Figure *External sensor supply, 2-wire transducer for SM 336; F-AI 6 x 0/4 ... 20 mA HART* in chapter "Properties, front view, wiring diagram and block diagram (Page 241)").

Note the influence of faults with a common cause.

You can use interconnection schemes A to D for this application.

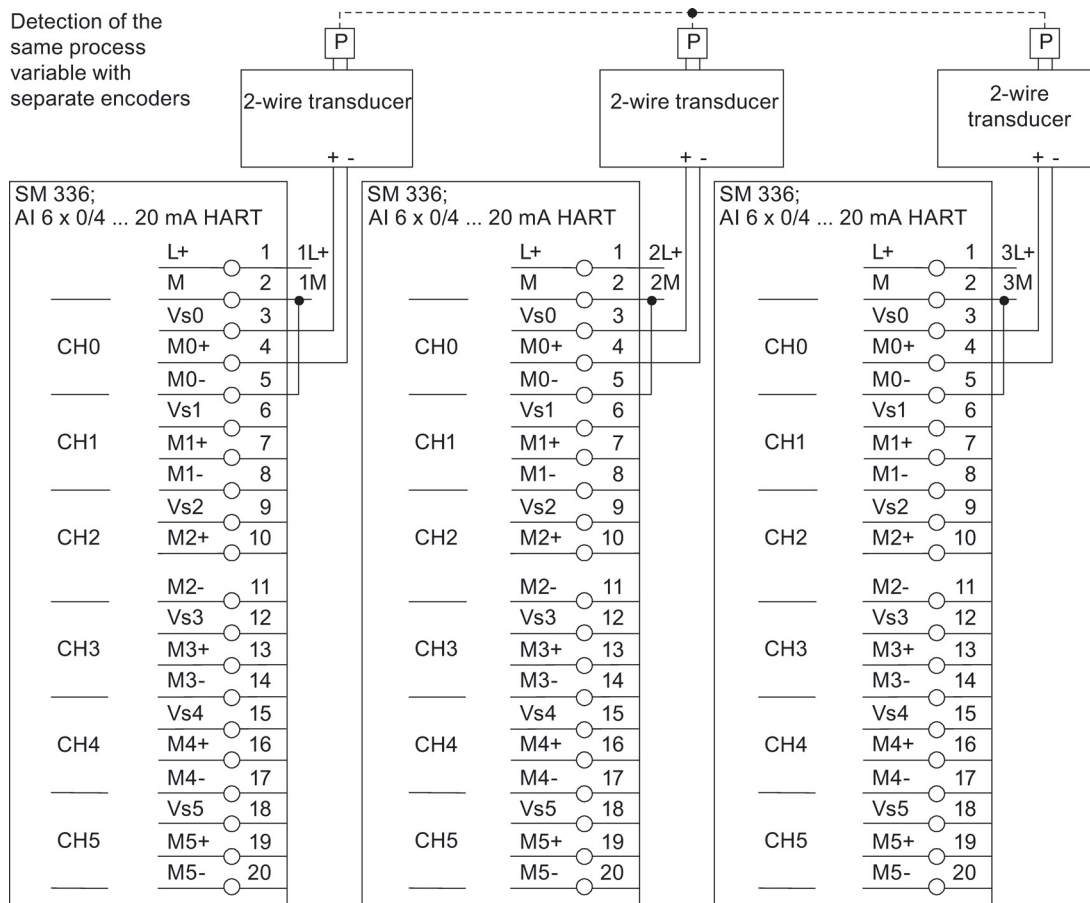

Figure 9-37 2oo3 evaluation with 3-fold redundant F-SMs, three-channel transducer

WARNING
 To achieve SIL3/Cat.4/PLe using this wiring, you must use a suitably qualified sensor.

Note

1L+, 2L+, and 3L+ can be fed from one power supply. The maximum permitted common mode voltage U_{CM} must be observed.

Assignable parameters for application 9

Table 9- 23 Parameters for application 9 of SM 336; F-AI 6 x 0/4 ... 20 mA HART

Parameters	Range of values in safety mode	Type	Effective range
Diagnostic interrupt	Activated/deactivated	Static	Module
Behavior after channel faults	Passivate the entire module/Passivate the channel	Static	Module
HART_Gate	Off/On/Can be switched	Static	Module
Interference frequency suppression	50 Hz/60 Hz	Static	Module
Evaluation of the sensors	1oo1 evaluation	Static	Channel
Measuring range	4 to 20 mA, 0 to 20 mA	Static	Channel
F-wire break detection	activated/deactivated (in the 4 to 20 mA measuring range)	Static	Channel
Smoothing	1 / 4 / 16 / 64 conversion cycles	Static	Channel
HART function	Activated/deactivated	Static	Channel
HART repetitions	0 to 255	Static	Channel
HART group diagnostics	Activated/deactivated	Static	Channel

Discrepancy analysis for fail-safe analog input modules

Perform a discrepancy analysis with 2oo3 evaluation in your safety program (e.g. in *S7 F/FH Systems* with the F_2oo3_AI F-block).

9.3.13 Diagnostic messages of SM 336; F-AI 6 x 0/4 ... 20 mA HART [ID: 6648621067]

Diagnostics using the LED display

The F-SM indicates faults by means of its SF LED (group fault LED). The SF LED is activated when the F-SM generates a diagnostic message.

The SF LED flashes as long as a cleared fault has not been acknowledged. It goes dark when all faults have been eliminated and acknowledged.

The SF LED flashes until you acknowledge passivation following a module fault.

Possible diagnostic messages

The following table provides an overview of the diagnostic messages for SM 336; F-AI 6 x 0/4 ... 20 mA HART.

Diagnostic messages are assigned either to a channel or to the entire module. Some diagnostic messages occur only in certain applications.

Table 9- 24 Diagnostic messages of SM 336; F-AI 6 x 0/4 ... 20 mA HART

Diagnostic message	Signaled in the application	Effective range of diagnostics	Assignable
No external auxiliary voltage	3 – 9	Module	No
Parameter assignment missing	3 – 9	Module	No
Incorrect module parameters	3 – 9	Module	No
Time monitoring activated	3 – 9	Module	No
Internal supply voltage of the module failed	3 – 9	Module	No
Processor failure	3 – 9	Module	No
EPROM error	3 – 9	Module	No
Communication error	3 – 9	Module	No
RAM error	3 – 9	Module	No
ADC/DAC error	3 – 9	Module	No
Discrepancy error	5 – 6	Channel	Yes
Short circuit of sensor supply to L+ *	3 – 9	Channel	No
Short circuit to M (test occurs cyclically)	3 – 9	Channel	No
Wire break **	3 – 9	Channel	Yes
Value is above the overrange	3 – 9	Channel	No
Value is below the underrange ***	3 – 9	Channel	No
HART: Primary variable outside the limits	3 – 9	Channel	Yes
HART: Non-primary variable outside the limits	3 – 9	Channel	Yes
HART: Analog output current saturated	3 – 9	Channel	Yes
HART: Analog output current specified	3 – 9	Channel	Yes
HART: Further status information available	3 – 9	Channel	Yes
HART: Configuration has changed	3 – 9	Channel	Yes
Malfunction of HART device	3 – 9	Channel	Yes
HART parameter assignment error	3 – 9	Channel	No
HART communication error	3 – 9	Channel	No
* is detected only during startup of the module			
** Wire break can be signaled for 0 to 20 mA and for 4 to 20 mA if "wire break diagnostics" is configured.			
*** Underrange can be signaled only with 4 to 20 mA and wire break diagnostics deselected.			

See also chapter " HART for safety-oriented applications (Page 307) "

Causes of the problem and corrective measures

The table below shows the possible causes of the problem and associated corrective measures for the individual diagnostic messages of the SM 336; F-AI 6 x 0/4 ... 20 mA HART.

Table 9- 25 Diagnostic messages and associated corrective measures for SM 336; F-AI 6 x 0/4 ... 20 mA HART

Diagnostic message	Possible causes of the problem	Corrective measures
No external auxiliary voltage	Module supply voltage L+ missing	Connect supply voltage L+
	Internal fuse defect	Module must be sent in.
Parameter assignment missing/incorrect parameters in the module	Faulty parameters transferred to module	Assign new module parameters
	F_destination_address incorrect	Check the address switch (DIP switch)
	CRC signature error during communication between the F-CPU and the module occurred, e.g., due to electromagnetic interference in excess of limits or sign-of-life monitoring error	Eliminate the interference
	Assigned monitoring time exceeded	Check the monitoring time parameters
	Startup of the fail-safe signal module	—
Time monitoring activated (watchdog)	Excessive electromagnetic interference at times	Eliminate the interference, and <ul style="list-style-type: none"> • Switch the supply voltage of the F-CPU/IM OFF/ON, • Remove/insert F-SM, or • Switch external auxiliary voltage of F-SM OFF/ON
	Firmware update cancelation due to error	If the error has gone out, repeat the firmware update.
	Defective module	Replace the module
Internal supply voltage of the module failed	Defective module	Replace the module
	Excessive electromagnetic interference at times	Eliminate the interference, and <ul style="list-style-type: none"> • Switch the supply voltage of the F-CPU/IM OFF/ON, • Remove/insert F-SM, or • Switch external auxiliary voltage of F-SM OFF/ON

Diagnostic message	Possible causes of the problem	Corrective measures
Processor failure	Electromagnetic interference has exceeded limits	Eliminate the interference, and <ul style="list-style-type: none"> Switch the supply voltage of the F-CPU/IM OFF/ON, Remove/insert F-SM, or Switch external auxiliary voltage of F-SM OFF/ON
	Defective module	Replace the module
	Ambient temperature too high	Check installation conditions, and <ul style="list-style-type: none"> Switch the supply voltage of the F-CPU/IM OFF/ON, Remove/insert F-SM, or Switch external auxiliary voltage of F-SM OFF/ON
	Switching rate exceeded	Reduce switching rate
EPROM error RAM error	Excessive electromagnetic interference at times	Eliminate the interference, and <ul style="list-style-type: none"> Switch the supply voltage of the F-CPU/IM OFF/ON, Remove/insert F-SM, or Switch external auxiliary voltage of F-SM OFF/ON
	Defective module	Replace the module
	Inconsistent firmware	Repeat firmware update
ADC/DAC error	Internal error during analog value test	Replace the module
	Impermissible U_{CM}	Eliminate the interference, and <ul style="list-style-type: none"> Switch the supply voltage of the F-CPU/IM OFF/ON, Remove/insert F-SM, or Switch external auxiliary voltage of F-SM OFF/ON
Firmware update successfully performed	—	—
Firmware update error	<ul style="list-style-type: none"> Firmware is faulty CRC error 	<ul style="list-style-type: none"> Switch the supply voltage of the F-CPU/IM OFF/ON, Remove/insert F-SM, or Switch external auxiliary voltage of F-SM OFF/ON Then, repeat the firmware update.
	Defective module	Replace the module
Firmware version inconsistent	<ul style="list-style-type: none"> Firmware is faulty Firmware update was canceled 	Repeat the firmware update.
	Supply voltage of module is missing	Connect the module to the supply voltage, and repeat the firmware update.

Diagnostic message	Possible causes of the problem	Corrective measures
Discrepancy error	Assigned tolerance window exceeded on expiration of the discrepancy time	Extend the tolerance window and/or discrepancy window
Short-circuit (short-circuit to L+ of sensor supply, ground short-circuit or defective sensor supply)	Wiring incorrect	Check wiring, and <ul style="list-style-type: none"> • Switch the supply voltage of the F-CPU/IM OFF/ON, • Remove/insert F-SM, or • Switch external auxiliary voltage of F-SM OFF/ON
	Applied external voltage	Remove the external voltage effect, and <ul style="list-style-type: none"> • Switch the supply voltage of the F-CPU/IM OFF/ON, • Remove/insert F-SM, or • Switch external auxiliary voltage of F-SM OFF/ON
	Defective module	Replace the module
Wire break	Interruption of the measuring lead between the module and sensor	Restore the cable connection
	Incorrect measuring range setting	Check the measuring range setting
Overflow or underflow of the measured value (see "Wire break and underflow" in Chapter "Analog value representation (Page 239)")	Measuring range fallen below	<ul style="list-style-type: none"> • Use suitable sensor, • check wiring (sensor polarity reversed) • Check sensor setting
	Measuring range exceeded	Use a suitable sensor; sensor polarity reversed
	Current through sensor too high at startup	—
Communication error	Error in communication between the CPU and the module, for example, due to defective PROFIBUS connection or electromagnetic interference in excess of limits	Check the communication connection
		Eliminate the interference
	Timeout of safety message frame monitoring	Check the monitoring time parameters
	CRC signature error, for example, due to electromagnetic interference in excess of limits or standard program accessing F-SM.	Eliminate the interference
	F-CPU has gone into STOP mode	Read out the diagnostic buffer of the F-CPU
	Inconsistent parameter assignment in <i>HW Config</i> and F-program	Recompile the project and download the S7 program again.

Diagnostic message	Possible causes of the problem	Corrective measures
HART: Primary variable outside the limits	<ul style="list-style-type: none"> • Assigned primary variable is outside the limits • Incorrect parameters in the HART field device • HART field device has simulation, and simulation setting is "Primary variable outside the limits" 	<ul style="list-style-type: none"> • Check the parameter assignment of the HART field device • Correct/deactivate simulation • Check whether the correct sensor is connected • End the measuring circuit test
HART: Non-primary variable outside the limits	<ul style="list-style-type: none"> • Assigned non-primary variable is outside the limits • Incorrect parameters in the HART field device • HART field device has simulation, and simulation setting is "Non-primary variable outside the limits" 	
HART: Analog output current saturated	<ul style="list-style-type: none"> • Incorrect parameters in the HART field device • HART field device has simulation, and simulation is set to a measured value that is too high • Assigned primary variable is outside the limits 	
HART: Analog output current specified	<ul style="list-style-type: none"> • Incorrect parameters in the HART field device • HART field device has simulation, and simulation is set to a measured value that is too high or HART field device is undergoing the measuring circuit test. 	
HART: Further status information available	HART field device supplies additional status	Read out status of the field device and correct, if necessary
HART: Configuration has changed	The identifier for reassignment of HART field device parameters has been set in the HART field device status (=HART status bytes).	—

Diagnostic message	Possible causes of the problem	Corrective measures
HART field device malfunction	Error occurred in the HART field device	<ul style="list-style-type: none"> • Check parameter assignment • Replace HART field device
HART parameter assignment error	Faulty HART parameters transferred to module (DS 131 – 136)	Correct HART parameter data record
	Error during dynamic parameter reassignment (HART)	<ul style="list-style-type: none"> • Check the parameter assignment in the user program • Contact SIMATIC Customer Support if necessary
HART communication error	<ul style="list-style-type: none"> • HART field device does not reply • Signal fault (level, timing, noise) 	<ul style="list-style-type: none"> • Check the process wiring • Check measuring current • Check the current consumption of the field device • Replace sensor • Increase the number of retries • Connect a capacitor of approximately 100 nF in parallel to the sensor

9.3.14 Technical Data - SM 336; F-AI 6 x 0/4 ... 20 mA HART [ID: 8681239435]

Overview

Technical specifications		
Dimensions and weight		
Dimensions W x H x D (mm)	40 × 125 × 120	
Weight	Approx. 350 g	
Module-specific specifications		
Number of inputs		
• One-channel	6	
• Two-channel	3	
Assigned address area		
• In the I/O input area	16 bytes	
• In the I/O output area	4 bytes	
Cable length		
• Shielded and twisted in pairs	Max. 1000 m	
Front connectors	20-pin	
Maximum achievable Safety Integrity Level in safety mode	One-channel	Two-channel
• According to IEC 61508:2000	Max. SIL 3	Max. SIL 3

Technical specifications		
<ul style="list-style-type: none"> According to ISO 13849-1:2006 or EN ISO 13849-1:2008 	Max. Cat. 3/PLe	Max. Cat. 4/PLe
Fail-safe performance characteristics		
<ul style="list-style-type: none"> low demand mode (average probability of failure on demand) 	< 1.00E-04	< 1.00E-05
<ul style="list-style-type: none"> high demand / continuous mode (probability of a dangerous failure per hour) 	< 1.00E-08	< 1.00E-09
Proof-test interval	20 years	
Voltages, currents, potentials		
Rated supply voltage of electronics L+	24 V DC	
<ul style="list-style-type: none"> Reverse polarity protection 	Yes	
<ul style="list-style-type: none"> Power loss ride-through of L+ 	None	
<ul style="list-style-type: none"> Power loss ride-through of internal voltage supply 	5 ms	
Electrical isolation		
<ul style="list-style-type: none"> Between channels 0/1/2 and 3/4/5, backplane bus, load voltage L+/sensor supply Vs0...5, shield 	Yes	
<ul style="list-style-type: none"> Between channels 3/4/5 and 0/1/2, backplane bus, load voltage L+/sensor supply Vs0...5, shield 	Yes	
<ul style="list-style-type: none"> Between backplane bus and channels 0/1/2, channels 3/4/5, load voltage L+/sensor supply Vs0...5, shield 	Yes	
<ul style="list-style-type: none"> Between load voltage L+/sensor supply Vs0...5 and channels 0/1/2, channels 3/4/5, backplane bus, shield 	Yes	
<ul style="list-style-type: none"> Between shield and channels 0/1/2, channels 3/4/5, backplane bus, load voltage L+/sensor supply Vs0...5 	Yes	
<ul style="list-style-type: none"> Between the channels of a potential group 	No	
Permitted potential difference		
<ul style="list-style-type: none"> Between the potential groups 	75 V DC, 60 V AC	
<ul style="list-style-type: none"> Between the channels (0/1/2 or 3/4/5) of a potential group 	75 V DC, 60 V AC	
Insulation test voltage	370 V AC for 1 min.	
Current consumption		
<ul style="list-style-type: none"> From backplane bus 	Max. 90 mA	
<ul style="list-style-type: none"> From supply voltage L+ (without load) 	Typ. 150 mA	

Technical specifications	
Common-mode voltage (CMV)	
• Permitted common mode voltage between the inputs (U_{CM})	75 V DC, 60 V AC
• Permitted common mode voltage between the inputs and M	75 V DC, 60 V AC
Power loss of the module	4.5 W, typical
Analog value generation	
Measuring principle	DELTA-SIGMA
Integration/conversion time	
• Configurable	Yes
• Integration time At 50 Hz At 60 Hz	20 ms 16.67 ms
• Response time per channel pair At 50 Hz At 60 Hz	25 ms 22 ms
• Basic response time	50 ms
• Resolution, including overrange	15 bits + sign
Smoothing of measured values (per channel)	Yes, assignable
Level	Time constant
• None	1 × conversion cycle time
• Weak	4 × conversion cycle time
• Medium	16 × conversion cycle time
• Strong	64 × conversion cycle time
Conversion cycle time = (basic response time + N × response time per channel pair) (N = number of active channel pairs)	
• At 50 Hz, all channel pairs active	125 ms
Acknowledgment time (DAT - Device Acknowledgement Time)	100 ms
Noise suppression, error limits	
Interference voltage suppression for $f=n \times (f1 \pm 0.5\%)$, ($f1$ =interference frequency)	
• Common-mode interference ($U_{CM} \leq 60$ V AC)	Min. 70 dB
• Series-mode interference (peak value of interference < rated value of input range)	Min. 40 dB
Crosstalk between inputs	Min. 70 dB
Operational limit (across the temperature range, relative to measuring range end value of 20 mA)	$\pm 0.2\%$ (40 μ A)

Technical specifications	
Basic error limit (operational limit at 25 °C, relative to full-scale value 20 mA)	± 0.1%
Temperature error (relative to full-scale value 20 mA)	± 0.002%/K
Linearity error (relative to full-scale value 20 mA)	± 0.01%
Repeatability (in steady state at 25 °C, relative to full-scale value 20 mA)	± 0.015%
Influence of a HART signal superimposed on the input signal (relative to the full-scale value 20 mA, in addition to the basic error)	
• 20 ms integration time	± 0.12%
• 16.67 ms integration time	± 0.12%
Status, Interrupts, Diagnostics	
Interrupts	
• Process interrupt	No
• Diagnostic interrupt	Yes, assignable
Diagnostics functions	
• Indication of safety-oriented operation	Green LED (SAFE)
• Channel fault display	Red LED (F0...5)
• Group fault display	Red LED (SF)
• HART status display	Green LED (H0...5)
• Diagnostic information can be read out	Yes
Fail-safe values can be switched to	Configurable in safety program
Sensor supply output	
• Number of outputs	6
Output voltage	
• Loaded	Minimum L+ (-0.5 V)
Output current	
• Rated value	300 mA
• Approved range	0 to 300 mA
Additional (redundant) infeed	With external additional elements, see wiring schemes
Short-circuit protection	
• Operating value	Typ. 1 A
• Permitted aggregate current of outputs	1.8 A
Shutdown at input	Typ. 35 mA
Sensor selection data	
Input range (rated values)/input resistance	
• Current	Typ. 150 Ω Max. 175 Ω

Technical specifications	
Permitted input current for current input (destruction limit)	Max. 40 mA
Safeguarding against short circuit in case of external sensor supply	e.g., melting fuse 62 mA FF
Signal sensor connection	
For current measurement	
• As 4-wire transducer	Possible
• As 2-wire transducer	Possible
HART communication	
Monodrop/multidrop operation	Monodrop operation
Primary/secondary master	Primary or secondary master *
Impedance of an input channel for HART communication.	100 – 150 Ω For operation with an external secondary master (e.g. communicator), an external load may be necessary to achieve a total impedance of 230 – 600 Ω.
Functional range of HART Communication	1.17 to typ. 35 mA
HART shutdown threshold	1.17 mA
Protocol version	5 to 6
Protection against overvoltage	
Protection of supply voltage L+ from surge stress according to IEC 61000-4-5	
Up to degree of severity 2	No external protective elements required
• Symmetrical (L+ to M)	± 0.5 kV; 1.2/50 µs
• Asymmetrical (L+ to PE, M to PE)	± 1 kV; 1.2/50 µs
Degree of severity 3 and higher	External protective elements required
• Symmetrical (L+ to M)	± 1 kV; 1.2/50 µs
• Asymmetrical (L+ to PE, M to PE)	± 2 kV; 1.2/50 µs
Protection of shielded signal lines (inputs) from surge stress according to IEC 61000-4-5	
Up to degree of severity 3	No external protective elements required
• Asymmetrical (shield to PE)	± 2 kV; 1.2/50 µs
To achieve failure criterion A according to IEC 61000-4-5..., the repetition factor for HART communication must be set at a value greater than 0.	
* In redundant operation, the module with the higher start address is automatically the secondary master.	

Note

The maximum cable lengths currently specified in this manual ensure against functional impairment, even without more precise examination of the boundary conditions. If the boundary conditions, such as EMC, cable type, cable routing, etc. are examined more closely, longer cables can be used for all F-SMs.

9.3.15 Parameters of analog input module F-AI 6 x 0/4 ... 20mA HART

[ID: 7100376075]

Table 9- 26 Parameters of module SM 331; F-AI 6 x 0/4...20mA HART

Parameters	Range of values	Default	Parameter type	Effective range
F-parameters				
F_Source_Address		Dependent on the F-CPU used	Static	Module
F_destination_address	1 to 1022	—		
DIP switch position (9.....0)	000000001 To 111111110	—		
F_Monitoring_Time (ms)	1 to 65535	2500		
Module parameters				
Diagnostic interrupt	Activated/deactivated	Deactivated	Static	Module
Behavior after channel faults	Passivate the entire module/Passivate the channel	Passivate the entire module		
HART_Gate	Off/On/Can be switched	Off		
Interference frequency suppression	50 Hz/60 Hz	50 Hz		
Evaluation of the sensors	1oo1 evaluation, 1oo2 evaluation / deactivated	1oo1 evaluation		Channel
Measuring range	4..20 mA / 0..20 mA	4...20 mA		
F-wire break detection	Activated/deactivated	Activated		
Smoothing	1, 4, 16, 64 conversion cycles	1 conversion cycle		
Discrepancy time (ms)	0 to 30000	150		
Tolerance window %, absolute	0.2 to 20	2,5		
Tolerance window %, relative	0.2 to 20	2,5		
Standard value	MAX/MIN	MIN		
HART				
HART function	On/off	Off	Static	Channel
HART repetitions	0 to 255	10		
HART group diagnostics	On/off	Off		

9.3.15.1 Setting smoothing of analog values [ID: 7168347787]

Setting smoothing of analog values

You can set smoothing of analog values for this module in *HW Config*.

Using smoothing

Smoothed analog values provide a reliable analog signal for further processing.

 WARNING
The smoothing takes place as a result of averaging over the selected number of conversion cycles, e.g., 64.
The result may be a delay in a discrepancy with 1002 evaluation (see example below).

Smoothing principle

The measured values are smoothed by digital filtering. Smoothing is accomplished by the module calculating mean values, derived from a defined number of converted (digitized) analog values.

You assign smoothing in 4 levels (after 1, 4, 16, or 64 conversion cycles). The grade determines the number of analog signals used for averaging. If smoothing = 1 conversion cycle is assigned, the smoothing is deactivated.

A higher smoothing provides a more stable analog value, and prolongs the time it takes to apply a smoothed analog signal following a unit step (see the example below).

Note

After startup, short circuit, wire break or exiting of the measuring range, smoothing is restarted. If, for example, smoothing = 16 conversion cycles is assigned and all channels are active, it takes up to 2000 ms at 50 Hz until the process value is signaled.

If a discrepancy occurs, measuring and smoothing continues and is not restarted.

Example

The figure below shows the number of cycles, depending on the smoothing setting, after which the analog value is completely smoothed and available in the case of a unit step. The figure applies to all signal changes at the analog input.

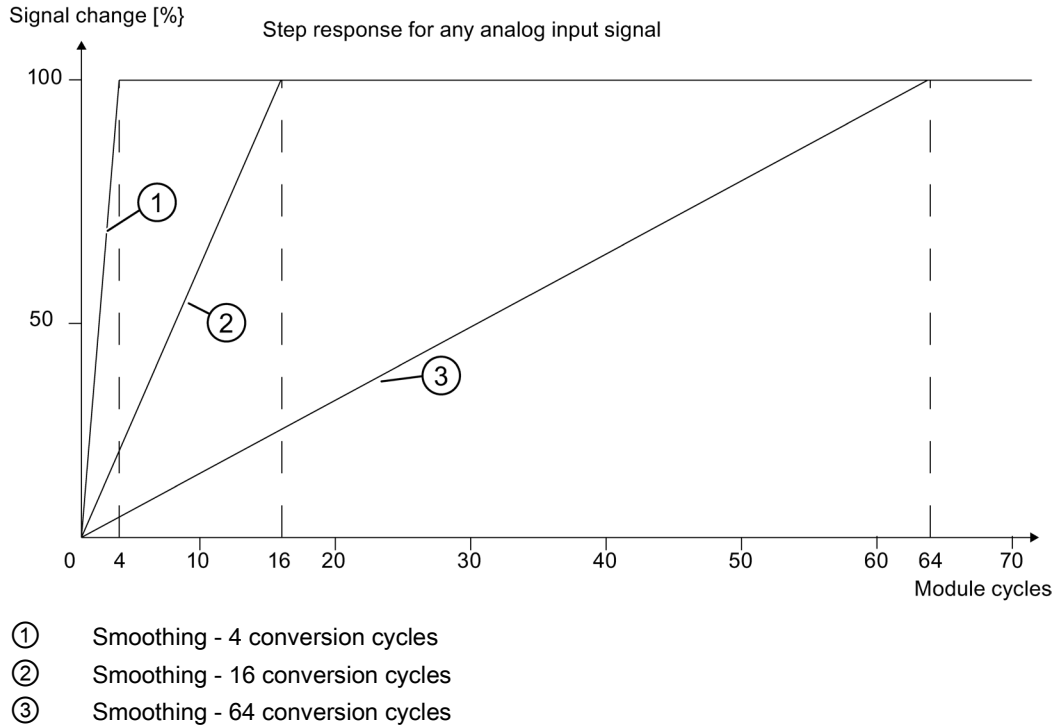

Figure 9-38 Example of effect of smoothing on step response

Example: Effect of smoothing on the maximum response time with 1oo2 evaluation with error

If an error occurred during 1oo2 evaluation, the maximum response time is calculated according to the following formula:

$$\text{Maximum response time (in case of discrepancy)} = 2 \times \text{Conversion cycle time} \times \text{Smoothing} + \text{Discrepancy time} + 2 \times \text{Conversion cycle time}$$

Where N represents the number of activated channel pairs

Example: one channel pair connected (N = 1), interference frequency 50 Hz, smoothing = 16 conversion cycles, discrepancy time = 2000 ms:

$$\text{Maximum response time (in case of discrepancy)} = 2 \times 125 \text{ ms} \times 16 + 2000 \text{ ms} + 2 \times 125 \text{ ms} = 6250 \text{ ms}$$

If a discrepancy exists between the two redundant input channels, it can take 6250 ms until the module signals the discrepancy error to the F-CPU (diagnostic interrupt is enabled).

If the discrepancy time expires, an error is signaled and the process data is set to 7FFF_H. In *S7 Distributed Safety*, the fail-safe value 0 is provided in the PII for the safety program in place of 7FFF_H.

9.3.15.2 Parameter assignment of discrepancy analysis for 1oo2 evaluation [ID: 7207419275]

Operating principle of discrepancy analysis

A discrepancy analysis is performed when 1oo2 evaluation is assigned.

An assignable tolerance window is formed around the process value that represents the instantaneous standard value (value that is signaled to the F-CPU).

The tolerance window is formed relative to the process value or as an absolute value relative to the measuring range end value. In addition, a relative tolerance window and an absolute tolerance window can be combined.

If the process value does not represent the standard value at an instant and is within the tolerance window, *no* discrepancy exists.

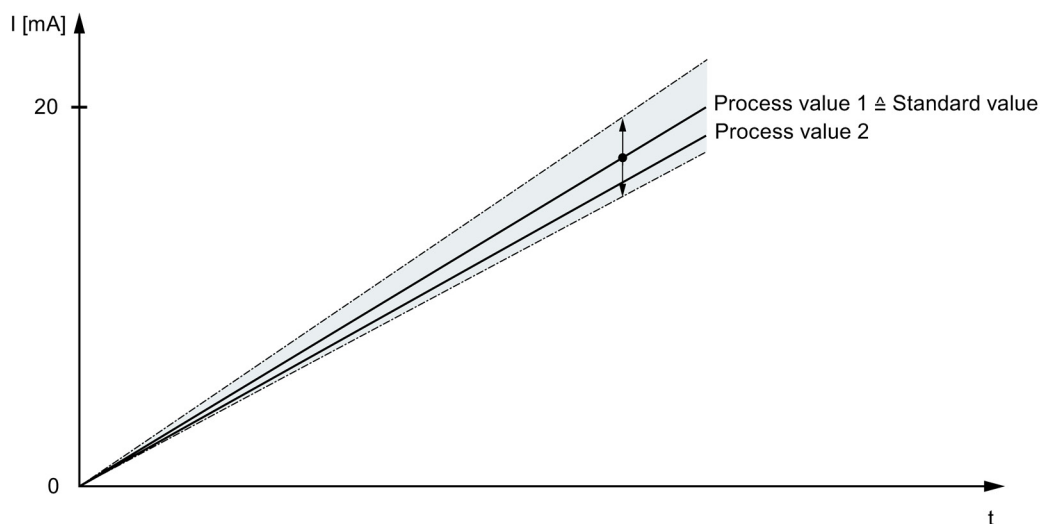

Figure 9-39 Example of a relative tolerance window *without* discrepancy (parameter assignment: standard value = MAX)

If the process value does not represent the standard value at an instant but is outside the tolerance window, a discrepancy exists.

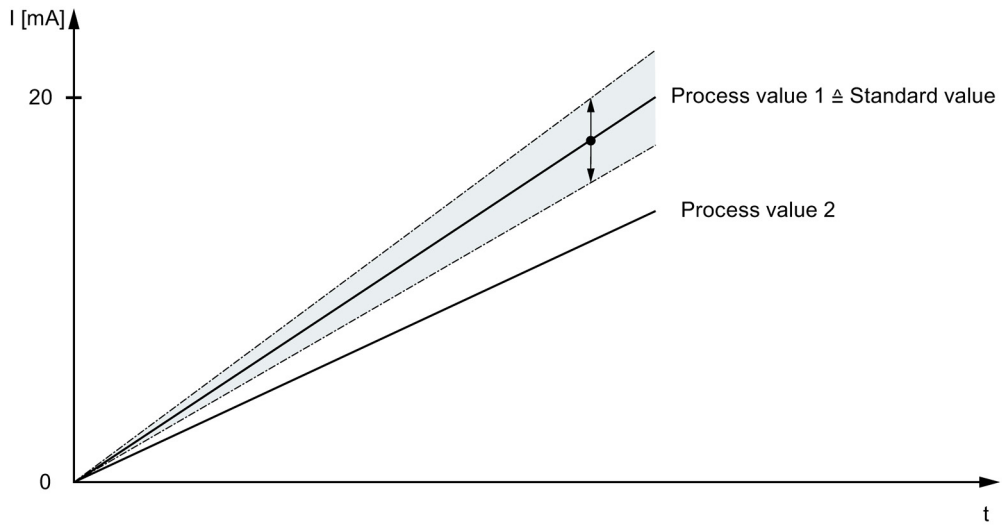

Figure 9-40 Example of a relative tolerance window *with* discrepancy (parameter assignment: standard value = MAX)

The assigned discrepancy time starts as soon as a discrepancy is detected. The discrepancy time runs as long as the discrepancy exists.

Depending on the configuration of the standard value (MAX or MIN), the next higher or lower "old" value is forwarded as the process value.

If the input channels fall below the specified tolerance prior to expiration of the discrepancy time (input channels are no longer discrepant), the discrepancy time is cleared and is restarted only when a new discrepancy is detected.

If the input channels are discrepant after startup or after a channel fault, 7FFF_H is output and the discrepancy time is started.

If the input channels are no longer discrepant when the discrepancy time expires, the standard value is output and the channel fault must be acknowledged. In this case, a channel-specific diagnosis is not signaled.

If the discrepancy time expires, an error is signaled and the process value is set to 7FFF_H. In *S7 Distributed Safety*, the fail-safe value 0 is provided in the PII for the safety program in place of 7FFF_H. In *S7 F/FH Systems* the fail-safe value assigned at the input SUBS_V of the channel driver will be provided in the PII.

A discrepancy error is handled by the safety program in the same way as a channel fault. For more information, refer to the *S7 Distributed Safety Configuring and Programming* or *S7 F/FH Systems Configuring and Programming* Programming and Configuring Manual.

Configuring the discrepancy analysis parameters

The following four parameters for the discrepancy analysis are assigned for each channel pair in *HW Config*.

- Discrepancy time
- Standard value
- Tolerance window %, absolute
- Tolerance window %, relative

"Discrepancy time" parameter

If the standard value of both input channels of a channel pair is outside the assigned tolerance window and exists longer than the specified discrepancy time but no more than the duration of the maximum response time, the module detects a discrepancy error. In the case of a discrepancy error, the module triggers a diagnostic interrupt and sets the process value to 7FFF_H. The discrepancy time is reset if the standard value lies within the tolerance window again.

In *S7 Distributed Safety*, the fail-safe value 0 is provided in the PII for the safety program in place of 7FFF_H.

In *S7 F Systems*, the fail-safe value is provided according to the F-channel driver parameter assignment.

You calculate the maximum discrepancy time that is permitted in the respective application using the following formula:

Discrepancy time = Maximum response time (in case of discrepancy) – 2 × Conversion cycle time × Smoothing – 2 × Conversion cycle time

Note

Calculate the discrepancy time by inserting the values from Chapter "Technical Data of the SM 336; F-AI 6 x 0/4 ... 20 mA HART (Page 287)" in the formulas shown above.

You can assign the discrepancy time for each channel pair. The entered value is rounded to an integer multiple of 10 ms. The value "0" is permitted. Small values other than 0 are rounded to a permissible minimum value.

"Standard value" parameter

You can select which of the two values is to be signaled to the F-CPU for each input channel pair. During a discrepancy between the two input channels, the last valid standard value prior to occurrence of the discrepancy is signaled to the F-CPU.

- "MIN": The lower of the two values is signaled to the F-CPU as the standard value.
- "MAX": The higher of the two values is signaled to the F-CPU as the standard value.

"Tolerance window %, absolute" parameter

You can calculate the absolute tolerance window using the following formula:

$$T_{abs} = \frac{|\Delta I_{abs}|}{I_{ME} - I_{MA}} \times 100 \text{ [%]}$$

Calculate the maximum deviation of the current using the following formula:

$$\Delta I_{abs} = \pm \frac{(I_{ME} - I_{MA}) \times T_{abs}}{100} \text{ [mA]}$$

With

- $I_{ME} = 20 \text{ mA}$
- $I_{MA} = 0 \text{ mA}$ for measuring range 0 ... 20 mA
- $I_{MA} = 4 \text{ mA}$ for measuring range 4 ... 20 mA
- $T = \text{Tolerance, in \%}$
- $\Delta I_{abs} = \text{Maximum deviation of current (+/-)}$

You can assign a value of 0.2 to 20% for the "Tolerance window %, absolute" parameter for each channel pair.

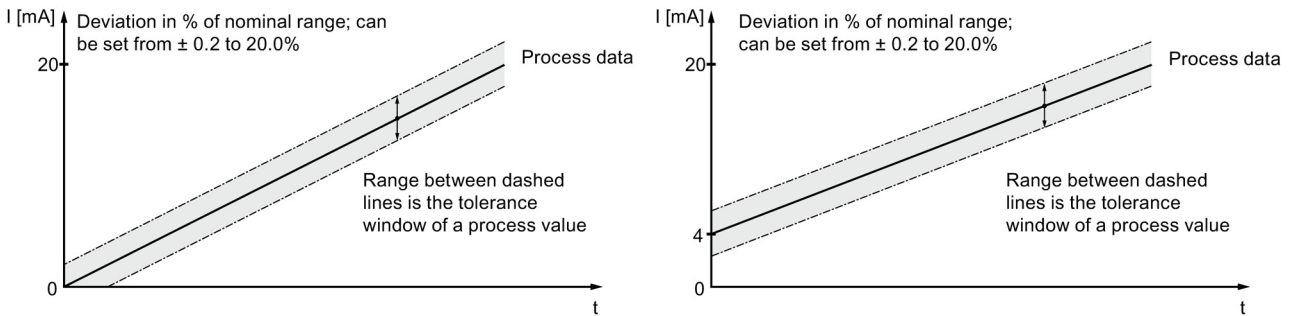

Figure 9-41 Absolute deviation in % of the nominal range for measuring range 0 to 20 mA or 4 to 20 mA

"Tolerance window %, relative" parameter

The tolerance window is calculated as a percentage of the *smoothed* process value that represents the MIN or MAX value (depending on the parameter assignment of the standard value) in this instant.

You can calculate the relative tolerance window using the following formula:

$$T_{\text{rel}} = \frac{|\Delta I_{\text{rel}}|}{|I_{\text{EW}} - I_{\text{MA}}|} \times 100 \text{ [%]}$$

Calculate the maximum deviation of the current using the following formula:

$$\Delta I_{\text{rel}} = \pm \frac{|I_{\text{EW}} - I_{\text{MA}}| \times T_{\text{rel}}}{100} \text{ [mA]}$$

With

- I_{EW} = Process standard value (min./max.)
- I_{MA} = 0 mA for measuring range 0 ... 20 mA
- I_{MA} = 4 mA for measuring range 4 ... 20 mA
- T = Tolerance, in %
- ΔI_{rel} = Maximum deviation of current (+/-)

You can assign a value of 0.2 to 20% for the "Tolerance window %, relative" parameter for each channel pair.

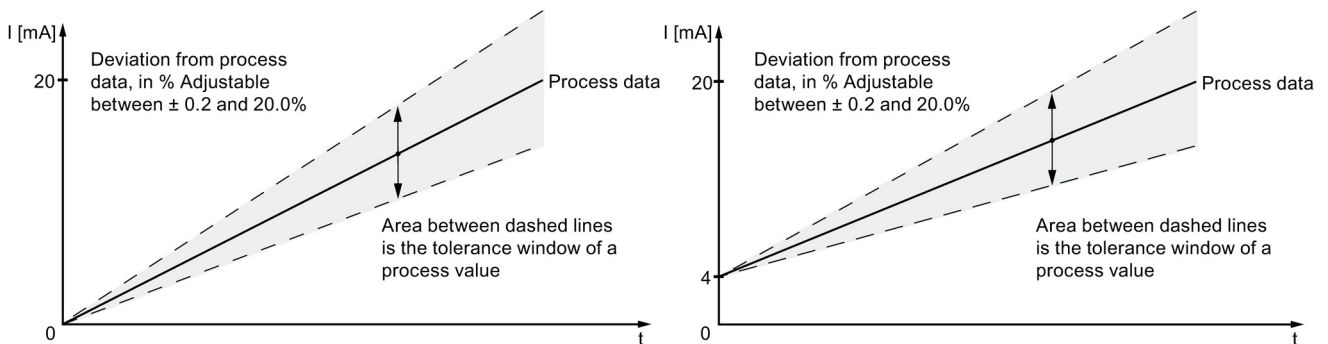

Figure 9-42 Relative deviation in % of the nominal range for measuring range 0 to 20 mA or 4 to 20 mA

Combination of the "Tolerance window %, absolute" and "Tolerance window %, relative" parameters

You can combine the "Tolerance window %, absolute" and "Tolerance window %, relative" parameters as needed. The combined tolerance window (shown in gray in the figure below) is the maximum of T_{rel} and T_{abs} .

$$T = \text{MAX} \{ T_{rel}, T_{abs} \}$$

$$\Delta I = \text{MAX} \{ \Delta I_{rel}, \Delta I_{abs} \}$$

Where (in both formulas above):

- T = Tolerance, in %
- ΔI = Maximum deviation of current (+/-)

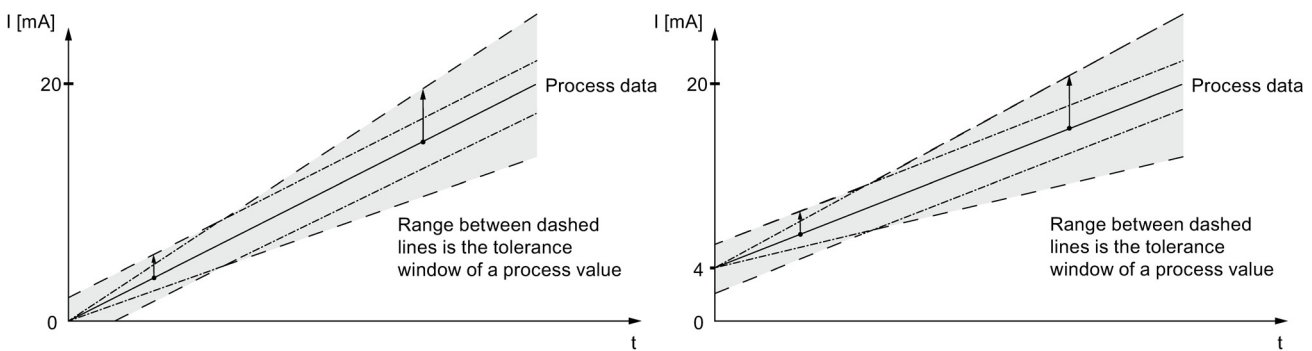

Example

The following figure shows you the behavior of the discrepancy evaluation when standard value = MAX.

The diagram above shows you the characteristic curve of the two process values. The dashed line represents the absolute tolerance range configured in this example.

The lower diagram shows you the standard value signaled to the F-CPU.

In this example, on the first occurrence of a discrepancy, process value 1 is *within* the tolerance range again *before* expiration of the discrepancy time. This means the discrepancy is not signaled.

In this example, on the second occurrence of a discrepancy, process value 1 is *outside* the tolerance range when the discrepancy time expires. As a result, a discrepancy is signaled with 7FFF_H after expiration of the discrepancy time. In *S7 Distributed Safety*, the fail-safe value 0 is provided in the PII for the safety program in place of 7FFF_H. In *S7 F/FH Systems* the fail-safe value assigned at the input SUBS_V of the channel driver will be provided in the PII.

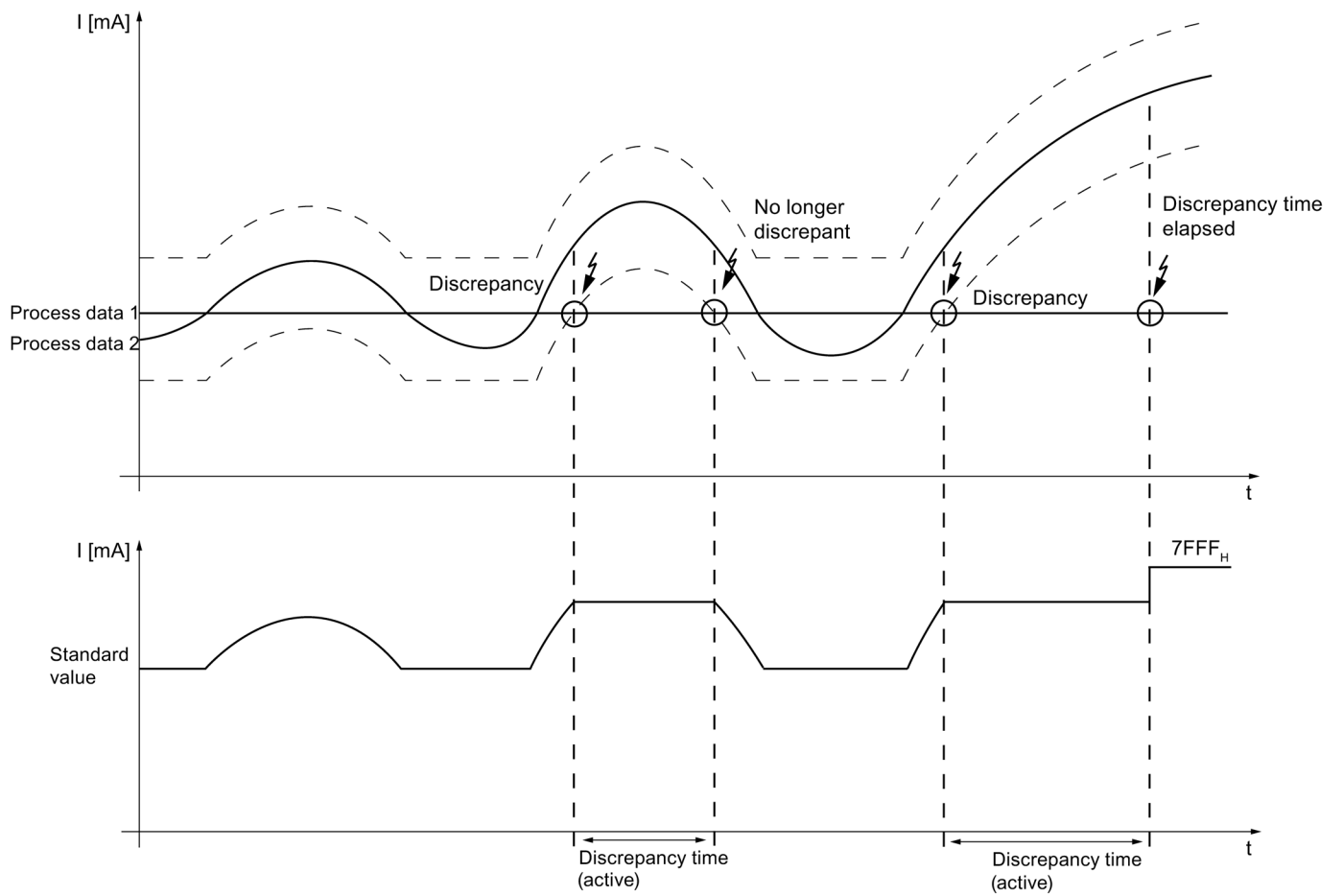

9.3.15.3 Deactivate one channel of a channel pair for 1oo1 evaluation [ID: 7760926091]

If you want to use only one channel of a channel pair (for 1oo1 evaluation), connect the unused channel to a resistance. Select the resistance to achieve a current between 4 and 20 mA.

9.3.16 HART basics

9.3.16.1 What is HART? [ID: 6877785099]

The HART function enables you to also operate the analog modules with digital communication options. The HART protocol has emerged as the de facto standard protocol for communication with intelligent field devices: HART is a registered trademark of the "HART Communication Foundation" (HCF), who owns all rights for the HART protocol.

Note

The SM 336; F-AI 6 x 0/4 ... 20 mA HART module supports the HART protocol version 5 to 6.

9.3.16.2 Properties of HART [ID: 6877777547]

What are the advantages of HART?

The use of HART analog modules offers the following advantages:

- Connection-compatible to analog modules: current loop 4 to 20 mA
- Additional digital communication via the HART protocol
- HART requires less power, important for use in hazardous areas
- Numerous field devices with HART functions currently in use

What are typical HART applications?

- Commissioning of field devices (central parameter assignment)
- Field device parameters can be changed online
- Information, maintenance and diagnostic displays for field devices

 WARNING
--

The HART protocol is not safety-oriented!

9.3.16.3 Principles of HART operation [ID: 7175090315]

Introduction

The HART protocol describes the physical form of the transfer:

- Transmission procedures
- Message structure
- Data formats
- Commands

HART signal

The following figure shows the analog signal with the HART signal modulated on it (FSK technique). The signal is composed of sine waves of 1200 Hz and 2200 Hz. It can be filtered out using an input filter so that the original analog signal is available again.

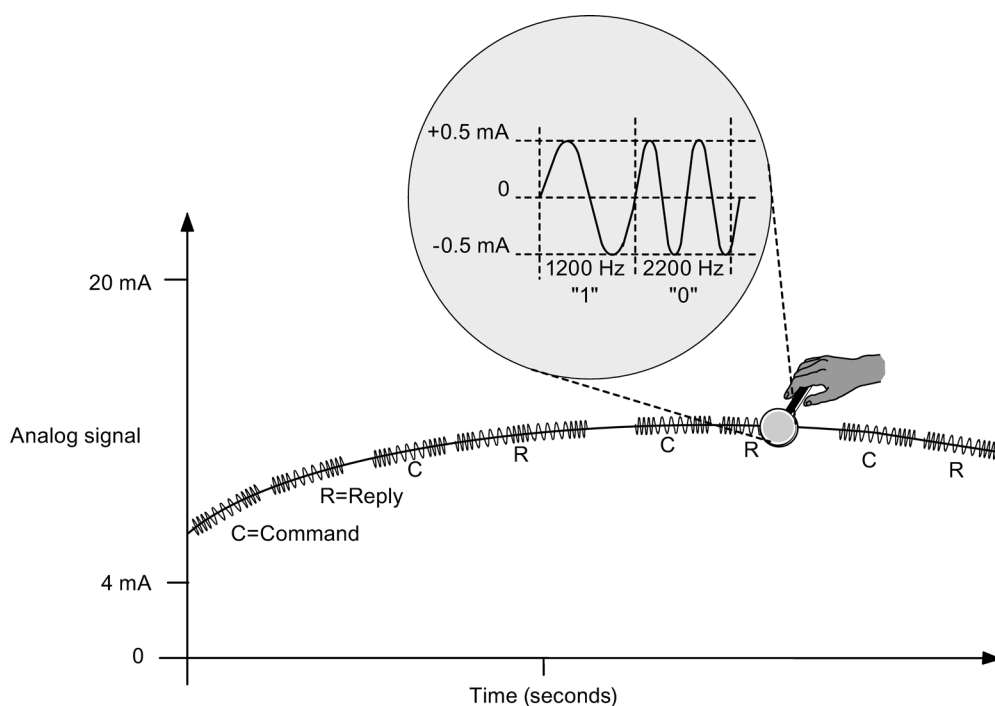

Figure 9-43 The HART signal

HART commands and parameters

You can use *SIMATIC PDM* to set the parameters of the HART field devices via **HART commands** and read these out via **HART replies**. The HART commands and their parameters are divided into three groups with the following properties:

- universal
- generally usable
- device specific

Universal command must be supported by all manufacturers of HART field devices; it is recommended that generally useable commands be supported. In addition there are device-specific commands, which only apply to the specific field device.

Examples of HART parameters

The following table shows HART parameters of various groups:

Table 9- 27 Examples of HART parameters

Parameter group	Parameters of the HART field device
universal	Measuring and manipulated variable (primary variable), manufacturer's name, process or actuator tags, other measured and manipulated values
generally usable	Measuring range, filter time, interrupt parameters (message, interrupt and warning limits), output range
device specific	special diagnostic information

See also

HART communication records (Page 314)

9.3.16.4 Integration of the HART field devices [ID: 7175091083]

Use of

The SM 336; F-AI 6 x 0/4 ... 20 mA HART can be used decentrally in an ET 200M for use of the HART function.

You can connect one field device to each of the 6 channels of the SM 336; F-AI 6 x 0/4 ... 20 mA HART. The analog module operates as the HART master, the field devices as HART slaves.

You can use *SIMATIC PDM* to communicate with the HART field device. *SIMATIC PDM* transmits and receives data via the HART analog module, comparable to a client for which the HART analog module acts as a server.

You also have the option to use the read/write data record mechanisms.

Command	Function
0	Reads the manufacturer and device type

Because the SM 336; F-AI 6 x 0/4 ... 20 mA HART supports only the "longframe command", the unique hardware address of the field device must be known.

Check byte 0 in the replay data record. As long as byte 0 = 0x03, the reply has not yet been completely received. With byte 0 = 0x04, there is a positive reply that you can evaluate.

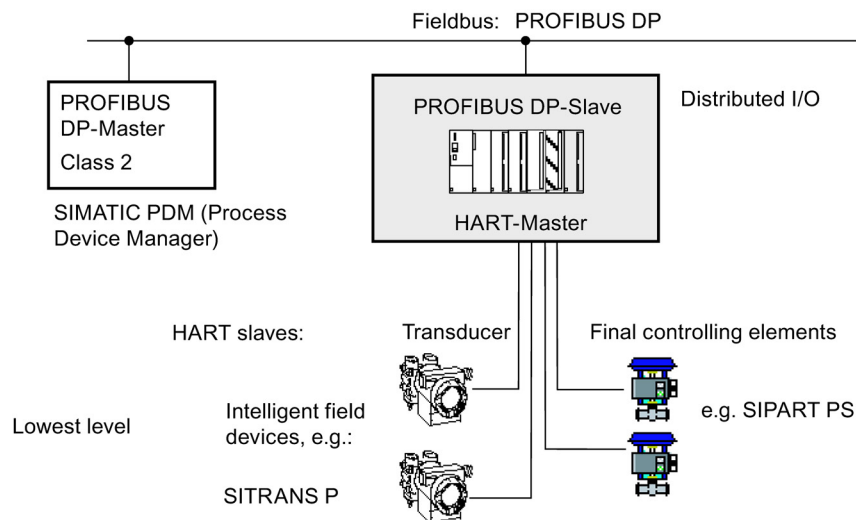

Figure 9-44 Location of use of the HART analog modules in the distributed system

See also

HART communication records (Page 314)

9.3.16.5 Using HART [ID: 7175091851]

System environment for using HART

To operate an intelligent field device with HART functionality, you require the following system environment:

Current loop 4 - 20 mA via the analog module SM 336, F-AI 6 x 0/4 ... 20 mA HART.

The module functions as a "master" by receiving the commands from the HART parameter assignment tool, passing them on to the intelligent field device and then returning the replies. The interface of the module is represented by data records that are transferred via the I/O bus. These data records are created or interpreted by the HART parameter assignment tool (*SIMATIC PDM*). *PDM* (Process Device Manager) is available as a stand-alone tool or as a tool integrated in *HW Config*. An option package is used for the latter.

The analog values are entered in 16-bit format in the process input and output image.

STEP 7, SIMATIC PDM, HART communicator

You can assign the HART parameters either with an external HART handheld device (HART communicator) or with *SIMATIC PDM*. *SIMATIC PDM* accesses through the module while the HART communicator is connected directly in parallel to the field device.

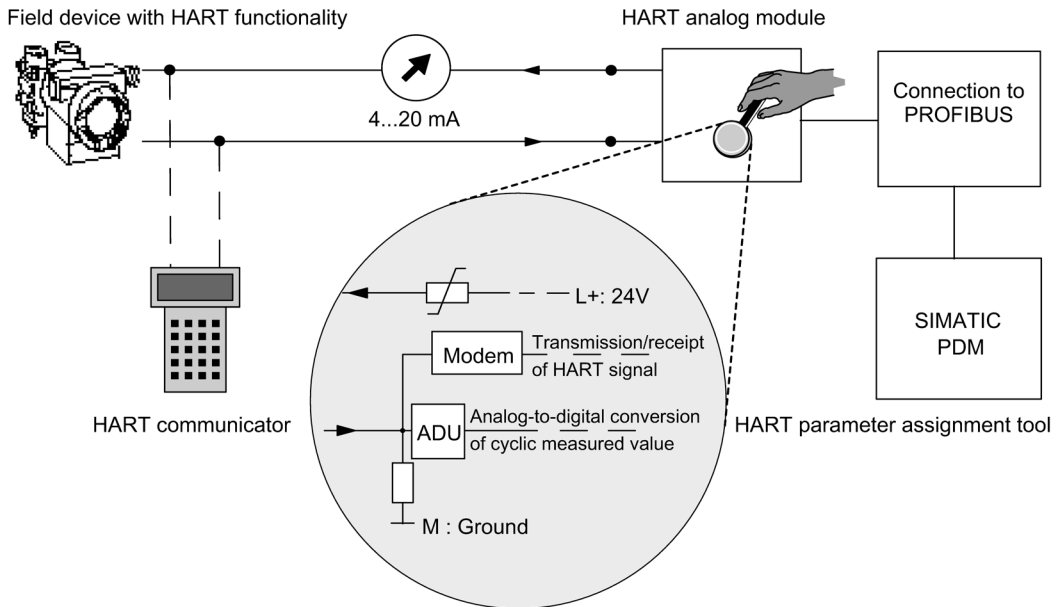

Figure 9-45 System environment for HART applications

Transparent message data - Format

The module supports the *transparent message data* format. Using *SIMATIC PDM*, you therefore have direct access to the HART field device for the commands and replies.

Each module is equipped with a common HART modem for the 6 channels. In other words, with *SIMATIC PDM* you can only directly access one channel of the module at any one time (multiplexes of the channels). It is not possible to simultaneously directly access another channel of the same analog module.

See also

HART for safety-oriented applications (Page 307)

9.3.16.6 HART for safety-oriented applications [ID: 7177502475]

Introduction

You assign the HART function in *HW Config* with the following parameters.

"HART_Gate" parameter

You use the "HART_Gate" parameter to enable the HART function (HART communication) for the *module*. The "HART_Gate" parameter acts as a module-wide *fail-safe* "main switch".

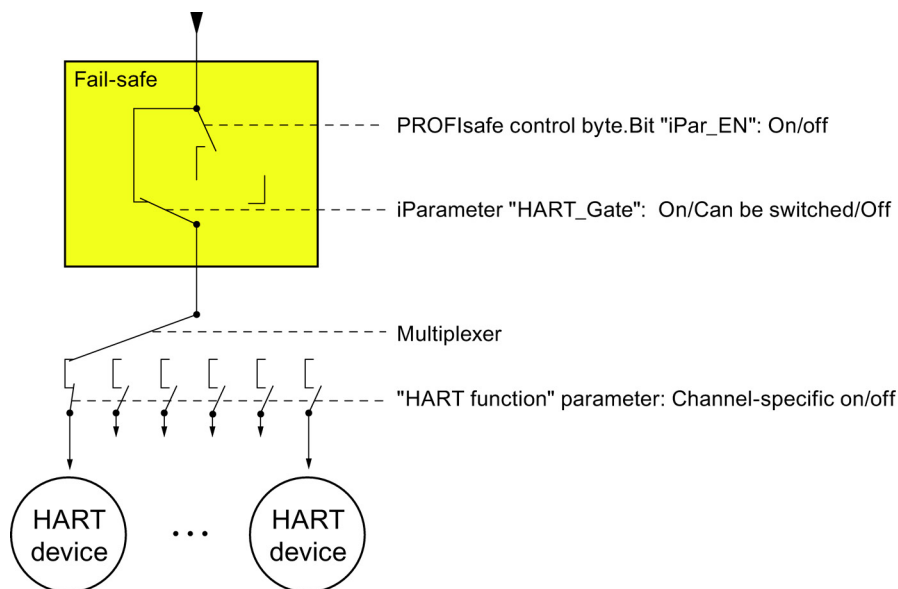

The following parameters of "HART_Gate" can be assigned:

- **"On"**: HART communication is enabled.
- **"Can be switched"**: The HART communication can be activated and deactivated from the safety program (*S7 Distributed Safety* or *S7 F Systems*), provided the module is in RUN mode. This means that the HART communication with HART field devices can be activated and deactivated during operation of the F-CPU (e.g. for maintenance purposes).

If you set the IPAR_EN variable of the F-I/O DB or of the F_CH_AI F-channel driver to "1" in the safety program, HART communication is enabled for the module. If the setting is "0", HART communication is disabled. The module acknowledges the enabled or disabled HART communication with variable IPAR_OK = "1" or "0" in the F-I/O DB or in the F_CH_AI F-channel driver.

Do not enable the HART communication until the status of your system allows the parameters of the associated HART field device to be safely reassigned.

If you want to evaluate the "Enable HART communication" status in your safety program, e.g., for the purpose of programming interlocks, you must generate the information as follows:

Set (primarily) the "Enable HART communication" signal if you enable the HART communication via IPAR_EN = 1. Reset the "Enable HART communication" signal with a falling edge of the IPAR_OK variable.

This is necessary to ensure that the information is properly available even if communication errors occur while the HART communication is enabled with IPAR_EN = 1. Only change the status of IPAR_EN during this evaluation if there is no passivation due to a communication error or F-I/O/channel fault (PASS_OUT = 0).

If you are using redundantly configured modules in *S7 F Systems*, you must set the IPAR_ENR variable of the F_CH_AI F-channel driver to "1" to enable the HART communication to the redundant HART field device. The redundantly configured module acknowledges the enabled or disabled HART communication with variable IPAR_OK = "1" or "0" in the F_CH_AI F-channel driver.

 WARNING
For module channels with HART devices <i>without</i> write protection, the following applies to an SIL 2/3 application: as soon as you open the HART_Gate, the input values of the channels must be checked for plausibility, e.g. by performing a comparison with the equivalent value of another module in the user program. Optionally, the module can also be taken out of the safety function of the system for this time.

 WARNING
Note that the opening of the HART_Gate is jumpered by a connected HART communicator.

Example of enabling HART communication in S7 F Systems

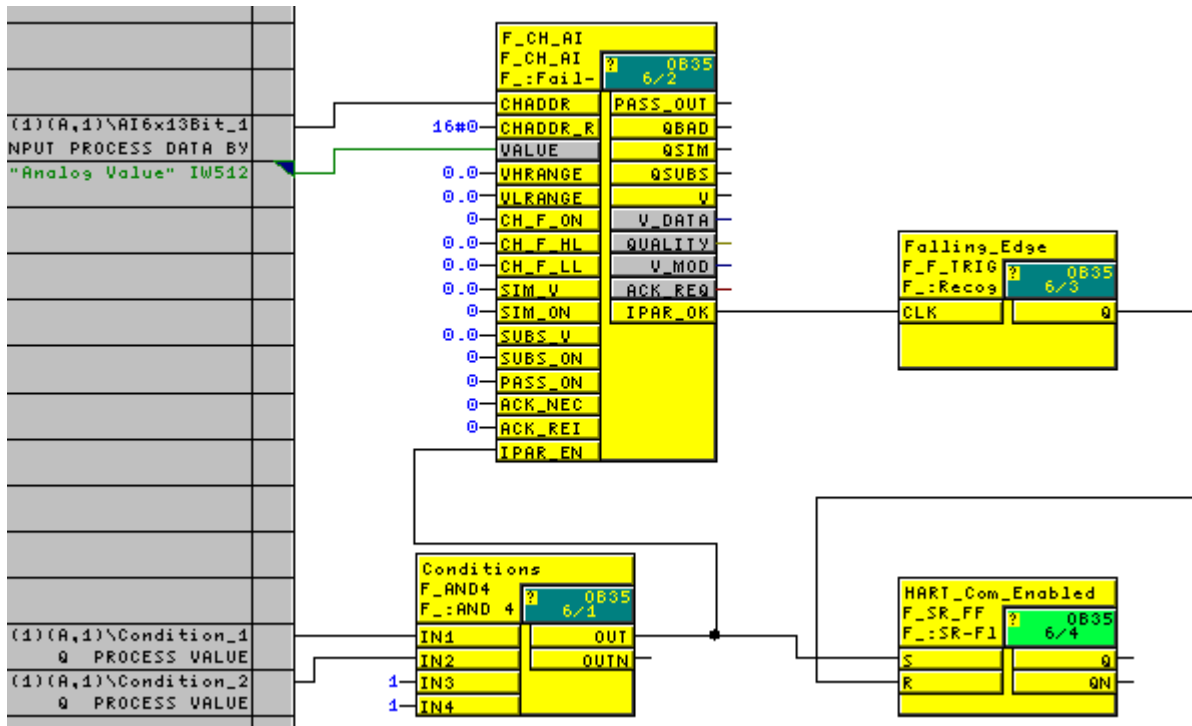
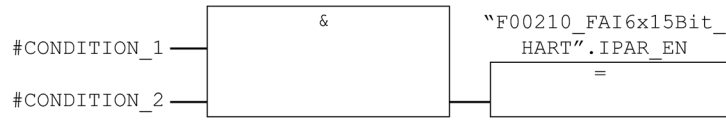

Figure 9-46 Example of enabling HART communication in S7 F Systems

Example of enabling HART communication in S7 Distributed Safety

Network 1: Enable HART communication

Comment:



Network 2: Determination that HART communication is enabled

Comment:

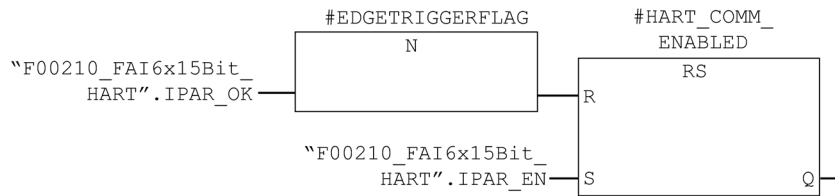

Figure 9-47 Example of enabling HART communication in *S7 Distributed Safety*

For additional information about the F-I/O DB, refer to the *S7 Distributed Safety, Configuring and Programming* manual. For additional information about the F_CH_AI F-channel driver, refer to the *S7 F/FH Systems, Configuring and Programming* manual.

- "Off": HART communication is disabled.

Note

HART diagnostics is only available when HART is activated. This also applies to *PCS 7* maintenance stations.

However, the module diagnostics is always available.

"HART function" parameter

You use the "HART function" parameter to enable or disable HART communication with the HART field device **for the relevant channel** of the module. The parameter is *not safety-oriented*, i.e., it cannot be used for *fail-safe shutdown* of HART communication.

The "HART function" parameter can only be assigned if the "HART_Gate" parameter = "On" or "Can be switched".

Activating HART according to the sensor used

The use of HART communication in safety-oriented applications is dependent on the HART-capable sensors you are using. The following figure shows the HART communication parameter assignment as a function of the sensor:

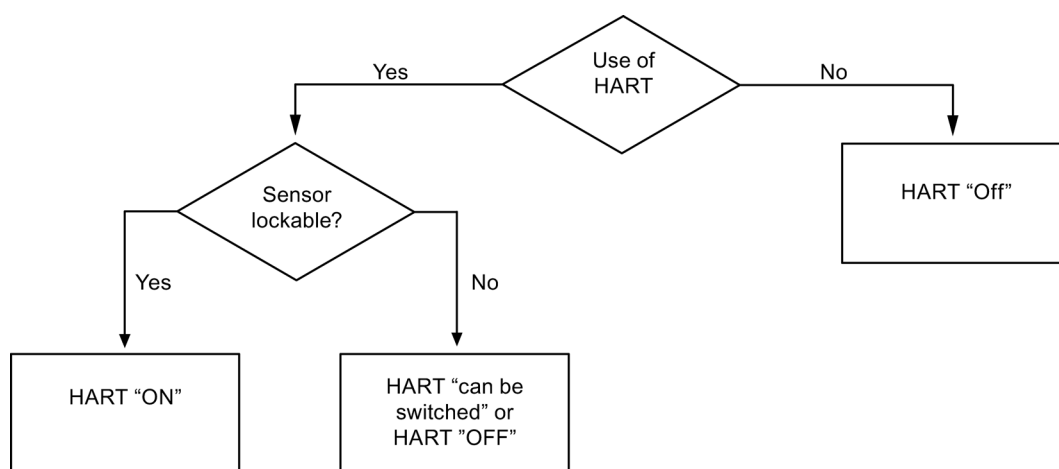

WARNING

As soon as a sensor does not comply with the required specifications, it can be used as a guideline (configure HART "can be switched").

Note

In the case of dual-channel interconnection of sensors, observe the notes in the chapters in which the application examples are described.

9.3.17 Data record interface and user data

9.3.17.1 Overview of the data record interface and user data of the HART communication [ID: 6878991115]

Introduction

In this chapter you will find the specific data that you require for parameter assignment, diagnostics and HART communication if you go beyond the standard applications of *STEP 7* or want to use your own configuration tool for HART communication.

The data made available cyclically (user data) is described at the end of the chapter.

Overview of the data record interface

The module uses data records as an input/output interface. They are used for the following applications:

- For writing parameters to the module
- For reading the diagnostic data from the module
- For transferring the HART communication data
- For writing the additional parameters for HART

The mapping of the HART commands and HART replies to the PROFIBUS-DP data records is based on the *PROFIBUS Profile HART Version 1.0*. Further information on the HART protocol can be found in the *PROFIBUS DP HART Profile Application Guideline*.

The documentation indicated above is available from PI (PROFIBUS International) on the Internet at <http://www.profibus.com>.

Table 9- 28 Additional parameters of the HART analog modules

Data record number	Read/write	Size in bytes	Description
148	Read	21	Directory Process Data
	DR information (directory data record): This data record contains the data record numbers (index) of all HART data records and information on numbers and revisions.		
149	Read	3	HMD Feature Parameter Process Data
	Optional HART functions (HART feature flags): This data record describes which optional HART functions are supported and specifies the maximum data field length of the request/reply data records.		
131 to 136	Read/write	8	HMD Parameter Process Data
	HART parameter data records: These data records contain the HART parameters for the module by channel (0 - 5).		

Data record number	Read/write	Size in bytes	Description
80, 82, 84, 86, 88, 90	Write	259	HART Request Write Process Data
	HART request data records to field devices: These data records contain by channel (0 - 7) the transfer data for the command from the client to the HART field device.		
81, 83, 85, 87, 89, 91	Read	259	HART Response Read Process Data
	HART reply data records from field devices: These data records contain the transfer data for the reply from the HART field device to the client by channel (0 - 5).		

Configure and assign parameters with *STEP 7*

You configure and assign parameters for the module with *HW Config*.

You can integrate certain additional functions for writing parameters and reading diagnostic data in your S7 program by means of SFCs.

Reading and writing data records

To read and write data records, use the following SFCs:

- Read data record: SFC 52 "REDREC"
- Write data record: SFC 53 "WRREC"

For more information about the SFCs, refer to the "System Software for S7 -300/400 System and Standard Functions (<http://support.automation.siemens.com/WW/view/en/1214574>)" manual.

Overview of the user data

The module has a user data area with the following content, which is provided similarly for channels 0 to 5:

- Current as analog input value

Relative addresses are specified in the description of the user data. The module address that you have to add to this can be determined in *HW Config*.

9.3.17.2 Diagnostic data records [ID: 6878998027]

Diagnostic data records

The diagnostic data records can be found in Appendix "Structure and Content of Diagnostic Data (Page 327)".

9.3.17.3 HART communication records [ID: 6878998795]

Transfer data records

HART communication can be controlled by one client per channel. Each channel has a separate transfer area available. Each transfer area consists of the command and reply data records.

Coordination rules for HART communication

- Fixed data record numbers are assigned to each client/channel:

Channel	Client	Data record
0	Command	80
0	Reply	81
1	Command	82
1	Reply	83
2	Command	84
2	Reply	85
3	Command	86
3	Reply	87
4	Command	88
4	Reply	89
5	Command	90
5	Reply	91

- After writing a command data record, a client has to read the reply data record before writing another command data record.
- From master class 2 (e. g. *SIMATIC PDM* or the engineering system with PROFIBUS master), the client can evaluate the "processing status" in the reply data record: If the processing status is "successful" or "faulty", the data record contains current reply data or error displays.
- The data record must always be read in its entirety, since after it is first read with a successful or faulty status, the data record can be changed by the module.
- The status component in the reply data record (= HART status bytes) provides information on whether and which errors have occurred.

Structure of the command data record

The figure below shows the command data record with which you can write a command to a client's transfer area. The HART analog module sends the command to the connected HART field device.

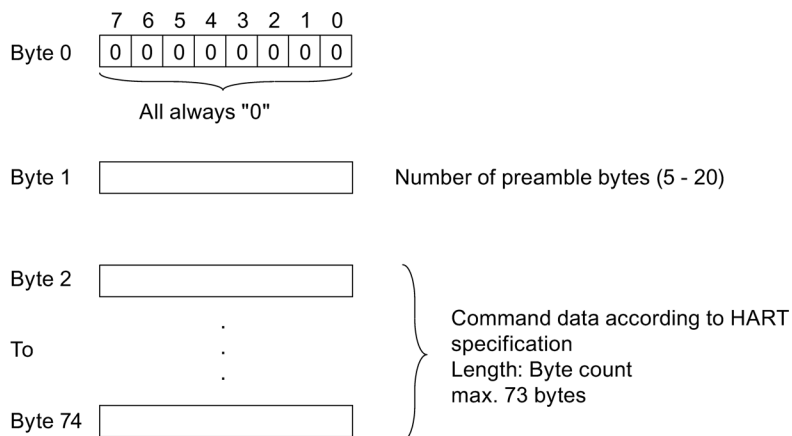

Figure 9-48 Command data record of the HART analog module

Notes on the command

The same client cannot send another command before reading the reply to the previous command.

Notes on the reply

When the reply data record is read, you must make sure that a current reply data record has arrived.

If the processing status is "successful" or "faulty", the data record contains current reply data or error displays.

Structure of the reply data record

The figure below shows the structure of the reply data record that contains the reply to the previous HART command and error or status.

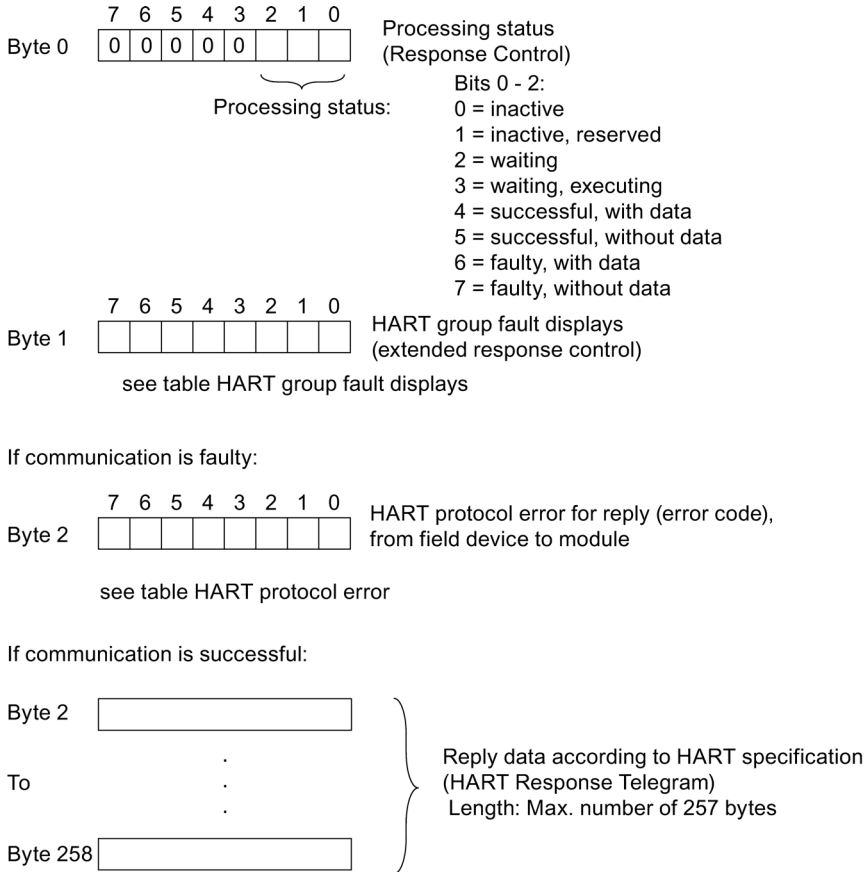

Figure 9-49 Reply data record of the HART analog modules

Evaluation of the reply data

If you have a current reply data record in front of you, you can carry out the following checks:

- By specifying "Last command", you ensure that the reply belongs to the command sent.
- You can identify errors by analyzing the group fault displays (see the table below).
- Further error messages are specified in the second table below (HART protocol errors in reply byte 2) and the two HART status bytes.
- In the group fault bytes in the error status the events are set to bits "1".

Table 9- 29 HART group fault displays in reply byte 1 (extended response control)

Bit no.	HART group fault display	Meaning
0	Further status information available	Corresponds to bit 4 in the channel-specific error bytes in diagnostic data record 1 (2nd HART status byte). The HART command 48 provides you with further status information, if required.
1	HART communication error --> HART communication error entry in diagnostic data record 1	Here the field device has identified a communication error on receiving the command. The error information is contained in the 1st HART status byte (in the reply data record or diagnostic data record 1) . This is accepted without being changed.
2	HART group fault display --> Parameter check	0: HMD parameters unchanged 1: Check HMD parameters
3	Always 0	Reserved
4 - 7	HART protocol error for reply --> HART communication error entry in diagnostic data record 1	Error during HART communication from the field device to the module (i.e. there was an error in receiving the reply). 0: Unspecified error 1: HMD error 2: Channel fault 3: Command error 4: Query error 5: Reply error 6: Query rejected 7: Profile query rejected 8: Vendor-specific query rejected 9 - 11: Not used 12 - 15: Vendor-specific status You will find information on the cause of the problem in reply byte 2. See the table below.

Table 9- 30 HART protocol error in reply byte 2 for the reply from the field device to the module (error code)

Error	HART protocol error in byte 2	Meaning
0	Unspecified error	0: Not specified
1	HMD error	0: Unspecified 1: Internal communication error 2: Parameter assignment error 3: HW error 4: Wait time expired 5: HART timer expired
2	Channel fault	0: Unspecified 1: Line error 2: Short circuit 3: Open line 4: Low current output 5: Parameter assignment error
3	Command error	0 - 127: HART protocol, Bit 7=0
4	Query error	HART protocol, Bit 7=1 Bit 0: Reserved Bit 1: Receive buffer overflow Bit 2: Reserved Bit 3: Checksum error Bit 4: Frame error Bit 5: Overflow error Bit 6: Parity error Bit 7: 1
5	Reply error	HART protocol, Bit 7=1 Bit 0: GAP timeout Bit 1: Receive buffer overflow Bit 2: Timeout Bit 3: Checksum error Bit 4: Frame error Bit 5: Overflow error Bit 6: Parity error Bit 7: 1
6	Query rejected	0: Unspecified 1: Short format not supported 2: SHC not supported 3: Impermissible command 4: No resources
7	Profile query rejected	0: Not specified (not supported)
8	Vendor-specific query rejected	0: Not specified (not supported)

See also

Integration of the HART field devices (Page 305)

9.3.17.4 Parameter records of the HART channels [ID: 6878999563]

Structure of parameter data records 131 to 136

The figure below shows the structure of parameter data records 131 to 136 for HART channels 0 to 5. The settings apply to the assigned channel:

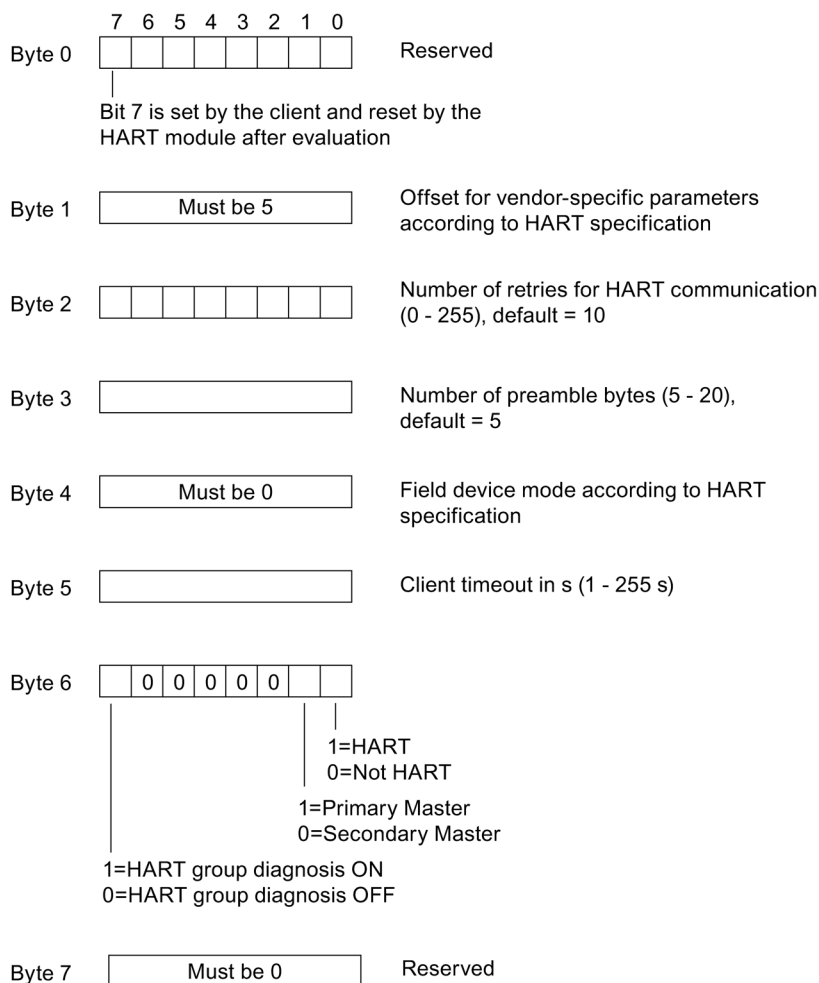

Figure 9-50 Parameter data records 131 to 136 of the HART analog modules

Notes on the parameter data records of the HART channels

The parameter data records contain parameters that you normally do not have to change, since the optimum value is already set.

9.3.17.5 User data interface, input range (reading) [ID: 6879078155]

Structure of the user data

The figure below shows the structure of the input user data area of the HART analog module.

You can read in the data of the user data area from the process image and evaluate it in your user program. For this purpose, see Chapter "F-I/O access" in the "S7 F/FH Systems Configuring and Programming (<http://support.automation.siemens.com/WW/view/en/16537972>)" or "S7 Distributed Safety Configuring and Programming (<http://support.automation.siemens.com/WW/view/en/22099875>)" manual

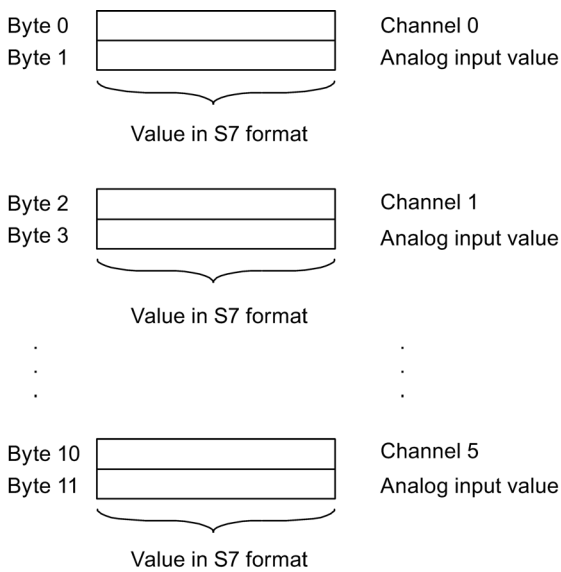

Figure 9-51 Input user data area of the HART analog modules

Safety protector

10.1 Introduction [ID: 431756427]

Chapter contents

The safety protector is used to protect the F-SMs from any overvoltage developing in the case of a fault/error. Information on safety protectors provided in this chapter:

- Properties
- Module view and block diagram
- Configuration variants
- Technical data

10.2 Properties, Front View, and Block Diagram [ID: 431759115]

Order number

6ES7195-7KF00-0XA0

Properties

The safety protector protects the fail-safe signal modules against excess fault voltages.

The safety protector does not occupy an address or supply diagnostic messages, and is not assigned in *STEP 7*.

Note

When the safety protector is used, your station achieves the limit values for *surge resistance* specified in the technical data using the overvoltage protection components specified in the "S7-300 CPU 31xC and CPU 31x: Hardware and Installation (<http://support.automation.siemens.com/WW/view/en/13008499>)" Operating Instructions only if configured with *grounded* reference potential.

If you install your station in a metal cabinet, you can configure the station with ungrounded or grounded reference potential.

Safety Integrity Level SIL 3/Cat. 4/PLe with safety protector

For applications in Safety Integrity Level SIL3/Cat.4 read the warning in section "Rules for using the safety protector" in the chapter "Configuration with F-SMs in Safety Mode (Page 21)".

Safety Integrity Level SIL 2/Cat. 3/PLd without safety protector

It is *not* required to install a safety protector if all components connected to PROFIBUS DP are compliant with PELV requirements (refer to the chapter *PELV for fail-safe signal modules*) when operated for applications of safety class **SIL2/Cat.3/PLd**.

Front view

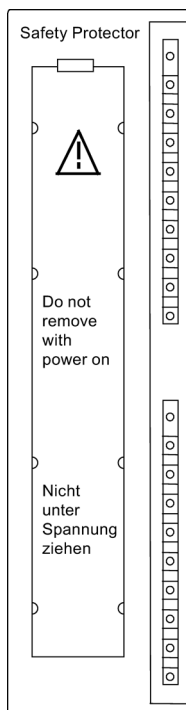

Figure 10-1 Front view of the safety protector

Block diagram

See the block diagram of the safety protector below.

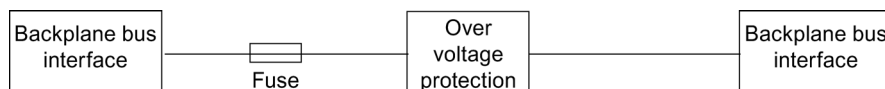

Figure 10-2 Block diagram of the safety protector

See also

Safe Functional Extra-Low Voltage for Fail-Safe Signal Modules (Page 46)

10.3 Configuration Variants [ID: 431761803]

Introduction

The module supports two variants with safety protector, depending on whether or not it is required to hot-swap a module.

Special features when using CPU 31xF-2 DP and CPU 31xF-2 PN/DP

Note the following special features with central or distributed operation of CPU 31xF-2 DP and CPU 31xF-2 PN/DP:

- The F-CPU reaches the limits for *surge* resistance specified in the technical data using the overvoltage protection components specified in the installation manual (<http://support.automation.siemens.com/WW/view/en/13008499>) only with *grounded* operation.
- If you operate a structure that does not require protective elements, either if surge protection is not required for your structure or if you have implemented other safety measures, you can create an *ungrounded* structure.

Configuration of S7-300/ET 200M with safety protector (no hot-swapping)

The safety protector increases the width of S7-300/ET 200M by 40 mm. This setup still permits installation of eight to twelve signal modules.

The example below shows a configuration with seven signal modules.

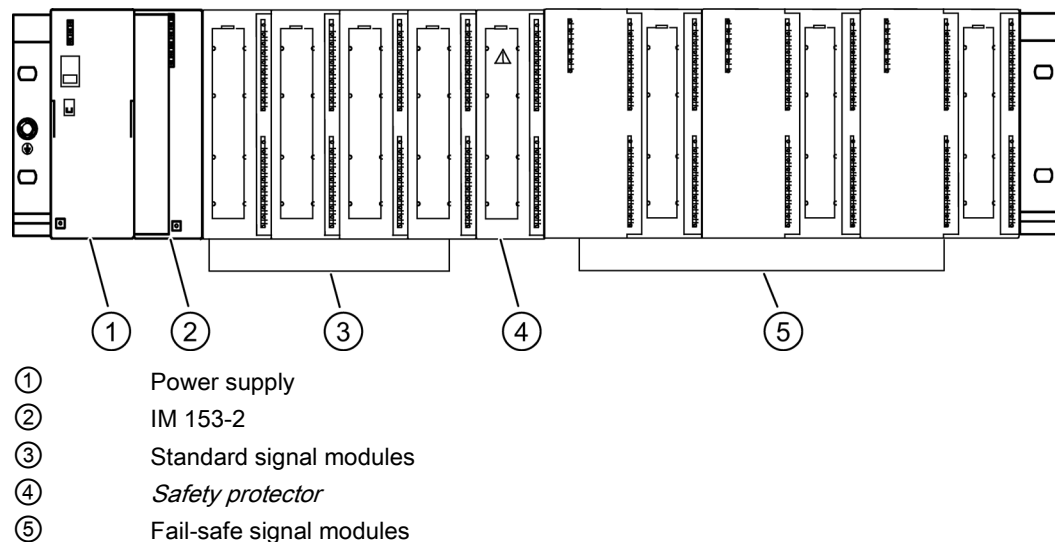

Figure 10-3 Configuration of ET 200M with safety protector (hot-swapping of the module not supported)

Note

Measures to be taken for overvoltage protection in safety mode:

- Always install the standard signal modules to the left of the safety protector; fail-safe signal modules are installed to the right of the safety protector.
 - Ground the mounting rail.
 - Bond the safety protector to functional ground. Interconnect pins 19 and 20 on the 20-pin front connector of the safety protector with the mounting rail using one cable each of the shortest possible length (conductor cross-section = 1.5 mm²).
-

Replacing modules in ET 200M when operating in safety mode

You can hot-swap all ET 200M submodules in a configuration with active bus modules, *with the exception of the safety protector.*

 **WARNING**

The safety protector (order no. 6ES7195-7HG00-0XA0) must be inserted at all times when operating the bus module for the safety protector. The bus module is only used to couple the safety protector to the active backplane bus.

DO NOT insert or remove the safety protector when the system is in operation! (any insertion or removal would inevitably lead to failure of the ET 200M.)

Configuration of ET 200M with safety protector on the active backplane bus

The bus module for the safety protector increases the width of ET 200M by 80 mm. You can still install eight to twelve signal modules. Note that you need the mounting rail for "Module replacement during operation" (order no. 6ES7195-1GX00) for the installation. The example below shows a configuration with seven signal modules.

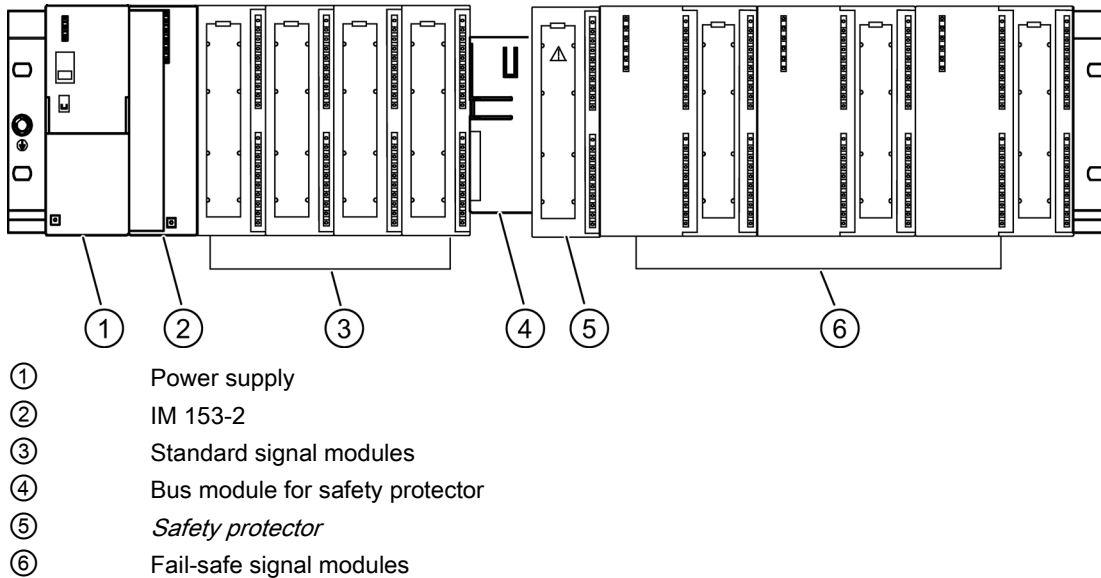

Figure 10-4 Configuration of ET 200M with safety protector on the active backplane bus

Note

Measures to be taken for overvoltage protection in safety mode:

- Always insert the standard signal modules on the left side of the safety protector; fail-safe signal modules are inserted on its right side.
- Ground the mounting rail.
- Bond the safety protector to functional ground. Interconnect pins 19 and 20 on the 20-pin front connector of the safety protector with the mounting rail using one cable each of the shortest possible length (conductor cross-section = 1.5 mm²).

10.4 Technical Specifications [ID: 431764491]

Overview

Technical data	
Dimensions and Weight	
Dimensions W x H x D (mm)	40 x 125 x 120
Weight	approx. 230 g
Module-Specific Specifications	
Front connectors	20-pin
Voltages, currents, potentials	
Power loss of the module	none

Diagnostics data of the signal modules

A.1 Introduction [ID: 431772299]

This appendix describes the structure of diagnostics data in system data. You need to know this structure if you want to evaluate diagnostics data of fail-safe signal modules in the default user program.

Additional references

For detailed information on the principle of the evaluation of diagnostics data of the modules and of the corresponding supported SFCs, refer to the *System and Standard Functions* reference manual.

A.2 Structure and Content of Diagnostic Data [ID: 431774987]

SFCs for reading diagnostics data

SFCs which can be used in the default user program to read diagnostics data from fail-safe signal modules:

Table A- 1 SFCs for reading diagnostics data

SFC number	Identifier	Application
59	RD_REC	Reading data records of S7 diagnostics (save to the data section of the default user program)
13	DPNRM_DG	Reading slave diagnostics data (save to the data section of the default user program)

Position in the diagnostic message frame of slave diagnostics

If the fail-safe signal modules of ET 200M are operated in a distributed configuration and a diagnostic interrupt occurs, data records 0 and 1 are entered in the slave diagnostics of ET 200M (= interrupt segment).

The position of the interrupt segment in slave diagnostics data depends on the structure of the diagnostic message frame and on the length of channel-specific diagnostics.

A detailed description of the structure of the diagnostic message frame and the position of the interrupt section in accordance with the PROFIBUS standard is available in the *Commissioning and Diagnostics* chapter of the "ET 200M Distributed I/O Device (<http://support.automation.siemens.com/WW/view/en/1142798>)" manual.

Data records 0 and 1 of system data

Module diagnostics data have a maximum length of 29 bytes and are saved to data records 0 and 1 in system data:

- Data record 0 contains 4 bytes of diagnostics data which describe the status of the fail-safe signal module.
- Data record 1 contains
 - 4 bytes of diagnostics data of the fail-safe signal module, which are also included in data record 0,
 - and up to 25 bytes of channel-specific diagnostics data

Description

The structure and content of the individual diagnostic data bytes are described below.

General rule: The corresponding bit is set to "1" if an error is detected.

Bytes 0 and 1

The diagram below shows the contents of bytes 0 and 1 in diagnostics data.

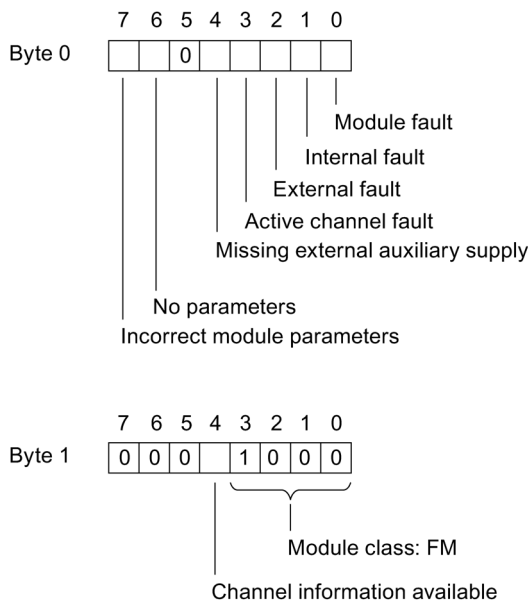

Figure A-1 Diagnostics data bytes 0 and 1

Bytes 2 and 3

The diagram below shows the contents of bytes 2 and 3 in diagnostics data.

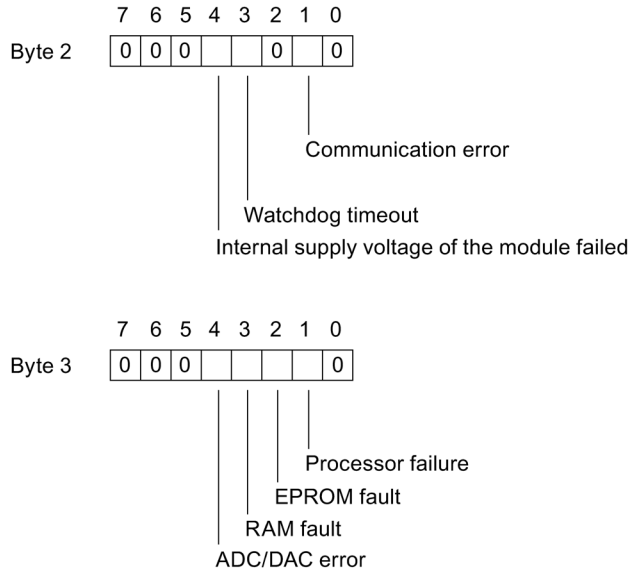

Figure A-2 Diagnostics data bytes 2 and 3

Bytes 4 to 6

The diagram below shows the contents of bytes 4 to 6 in diagnostics data.

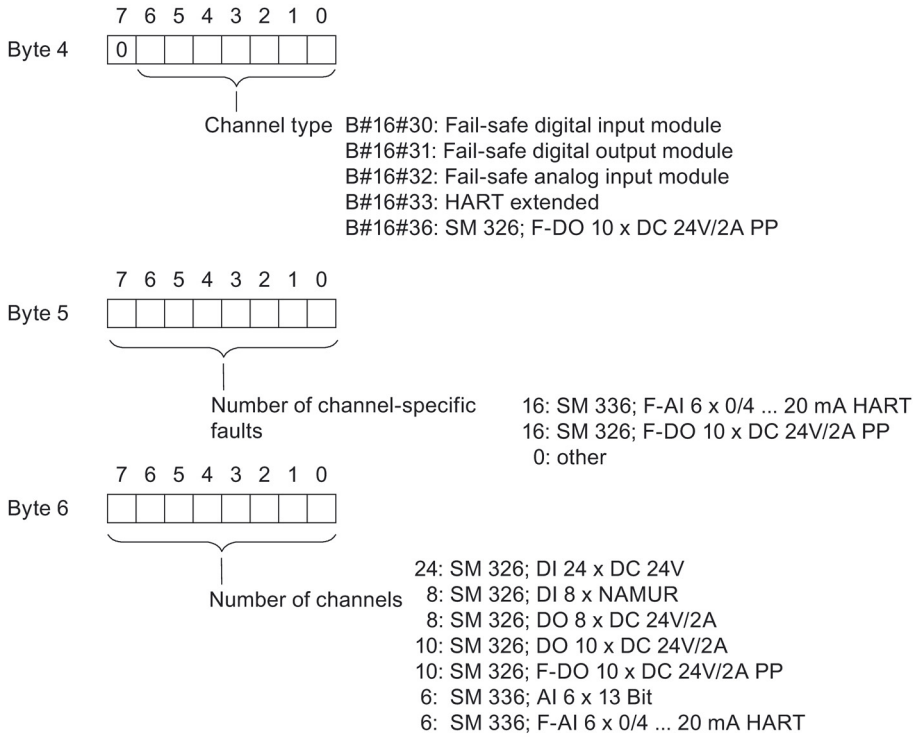

Figure A-3 Diagnostics data bytes 4 and 6

Bytes 7 to 9 with SM 326; DI 24 x DC 24V

The following figure shows the content of bytes 7 to 9 of the diagnostic data for the SM 326; DI 24 x DC 24V.

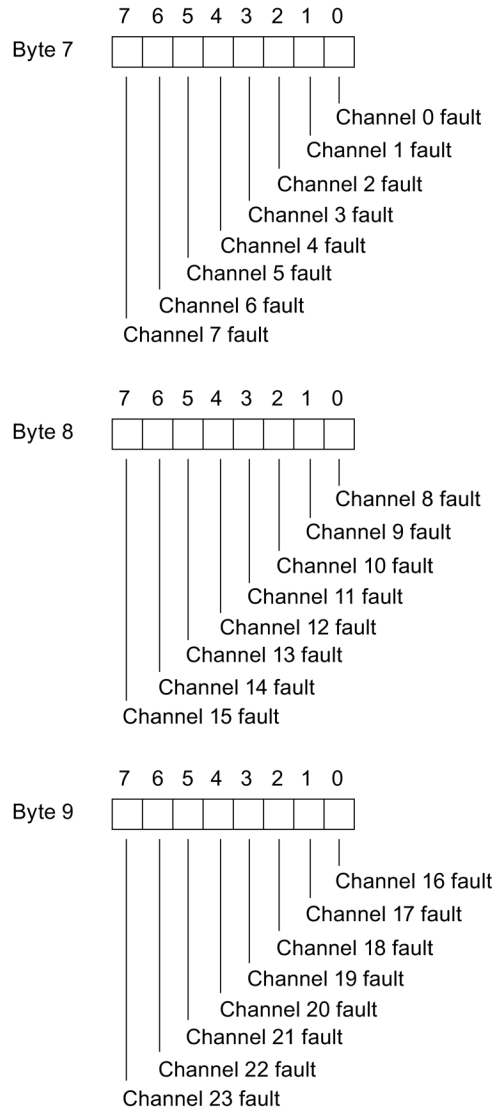

Figure A-4 Diagnostics data bytes 7 to 9 SM 326; DI 24 x DC 24V

Byte 7 with SM 326; DI 8 x NAMUR

The following figure shows the content of byte 7 of the diagnostic data for the SM 326; DI 8 x NAMUR.

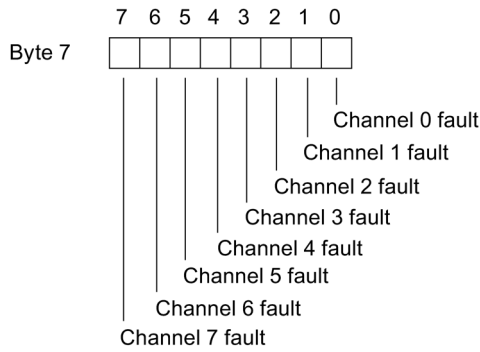

Figure A-5 Diagnostics data byte 7 with SM 326; DI 8 x NAMUR

Byte 7 with SM 326; DO 8 x DC 24V/2A PM

The following figure shows the content of byte 7 of the diagnostic data for the SM 326; DO 8 x DC 24V/2A PM.

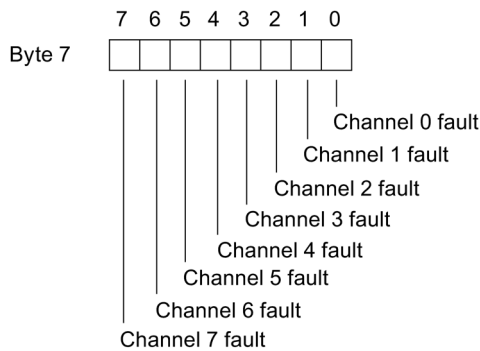

Figure A-6 Diagnostics data byte 7 with SM 326; DI 8 x DC 24V/2A PM

Bytes 7 and 8 with SM 326; DO 10 x DC 24V/2A

The following figure shows the content of bytes 7 and 8 of the diagnostic data for the SM 326; DO 10 x DC 24V/2A.

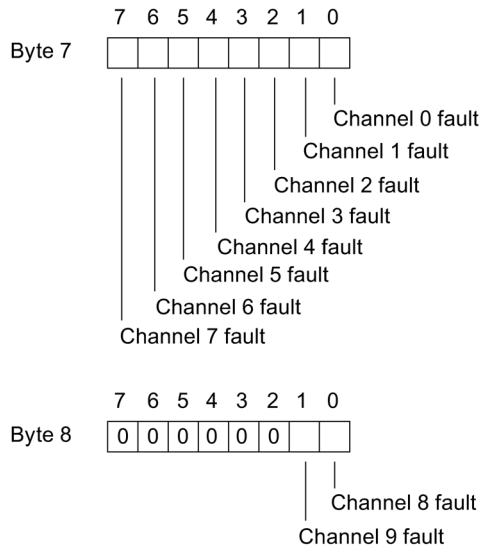

Figure A-7 Diagnostics data bytes 7 and 8 with SM 326; DO 10 x DC 24V/2A

Bytes 7 to 28 with SM 326; F-DO 10 x DC 24V/2A PP

The following figure shows the content of bytes 7 to 28 of the diagnostic data for the SM 326; F-DO 10 x DC 24V/2A PP.

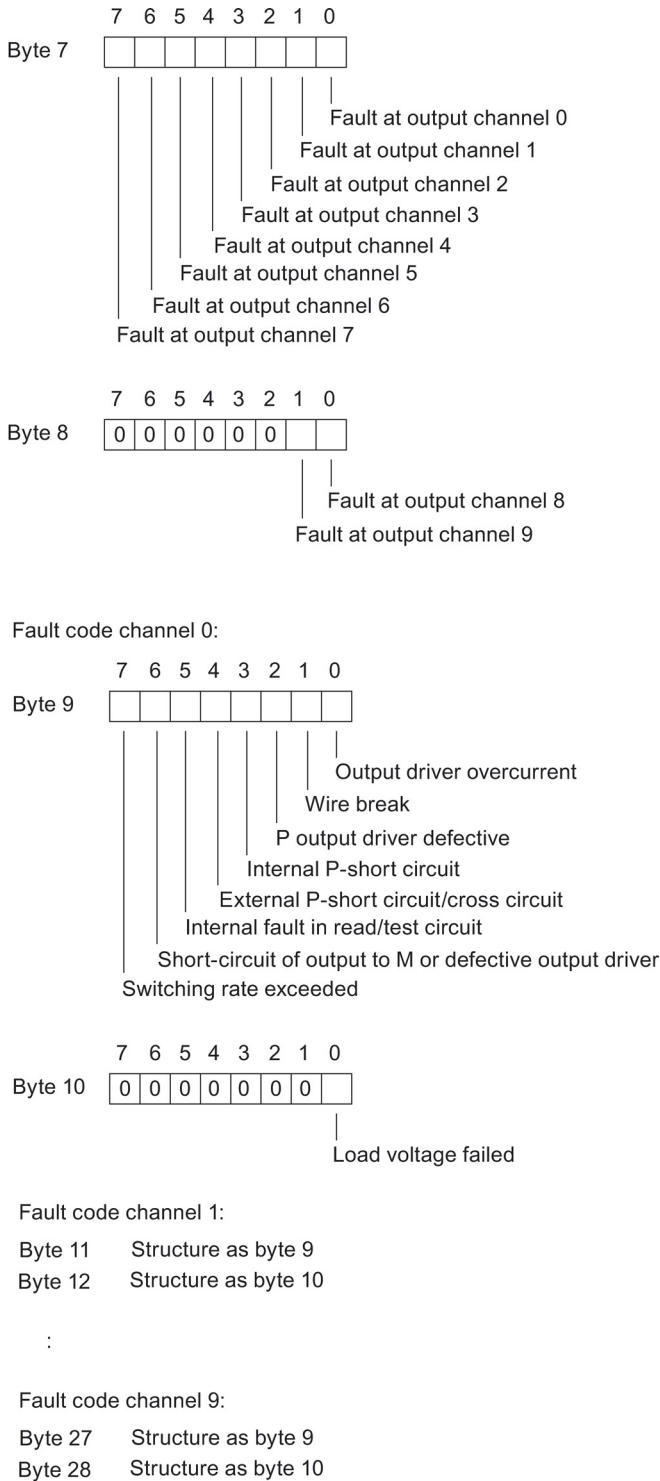

Figure A-8 Diagnostics data bytes 7 to 28 with SM 326; F-DO 10 x DC 24V/2A PP

Byte 7 with SM 336; AI 6 x 13Bit

The following figure shows the content of byte 7 of the diagnostic data for the SM 336; AI 6 x 13Bit.

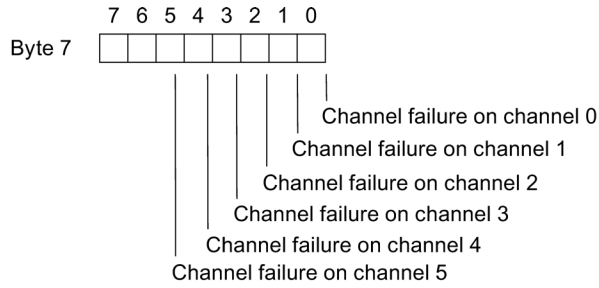

Figure A-9 Diagnostics data byte 7 with SM 326; AI 6 x 13 Bit

Diagnostics with SM 336, F-AI 6 x 0/4 ... 20 mA HART

The figure below shows the contents of bytes 4 to 19 of the diagnostics data.

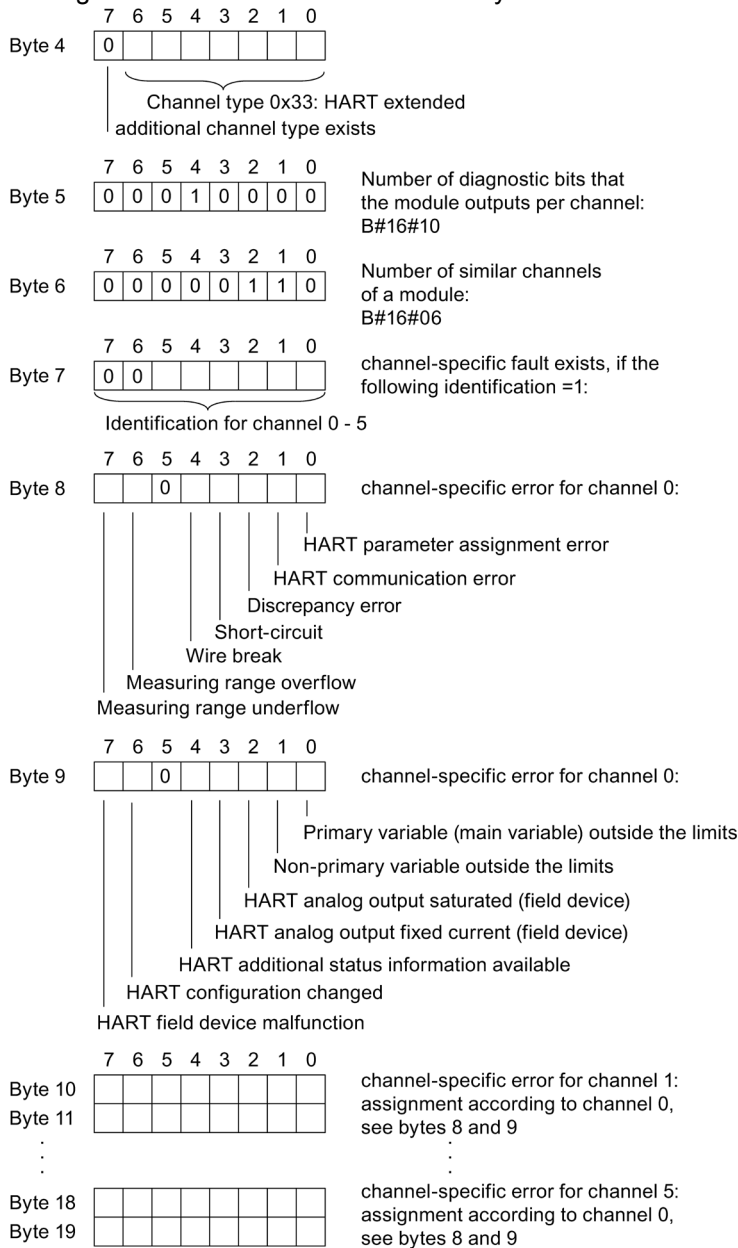

Figure A-10 Diagnostics data record as of byte 4 with SM 336, F-AI 6 x 0/4 ... 20 mA HART

Note

Note the following regarding diagnostics data:

If a HART channel fault is set, you receive additional information if you read in the status component (= HART status bytes) in the HART reply data record for the corresponding client or the diagnostics data record for the corresponding channel with SFC 59.

Dimensional drawings

B.1 Signal Module [ID: 431501835]

Dimensional drawing of the signal module

The signal module dimensions are shown in the dimensional drawing below (no hot-swap functionality). The signal modules may differ in terms of their appearance. However, the dimensions always remain the same.

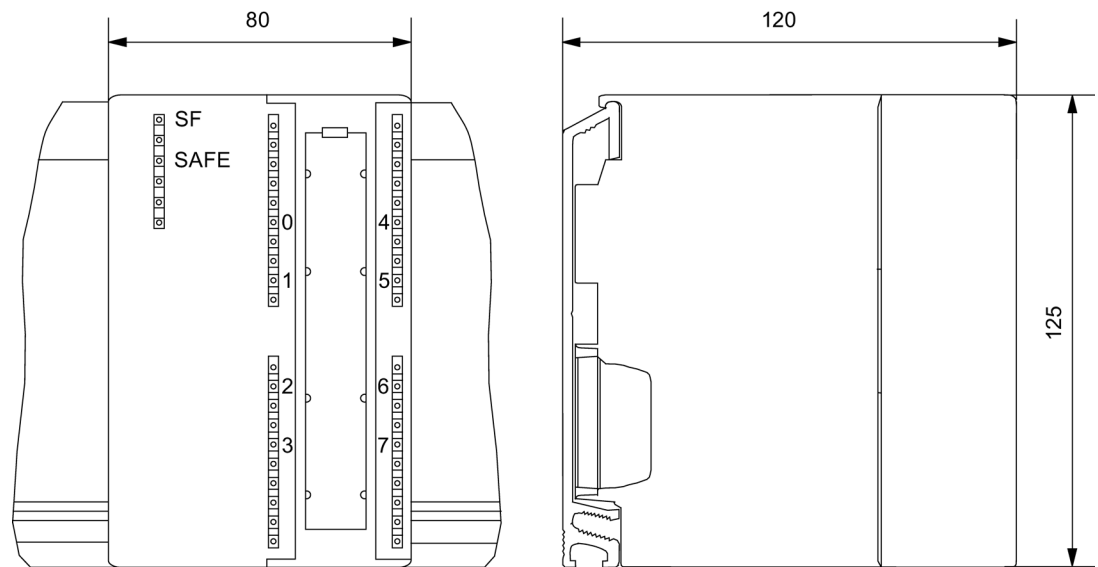

Figure B-1 Dimensional drawing of a signal module

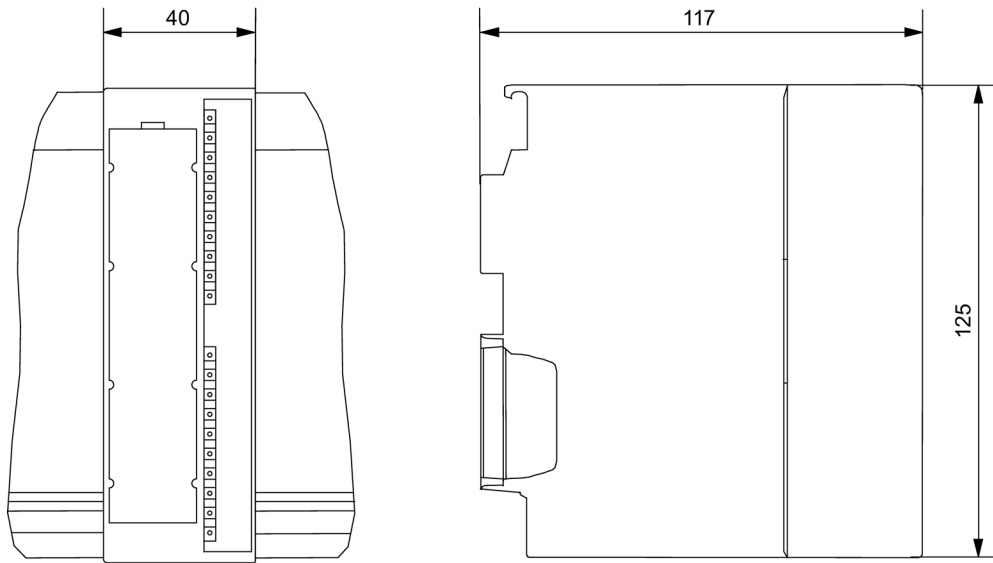
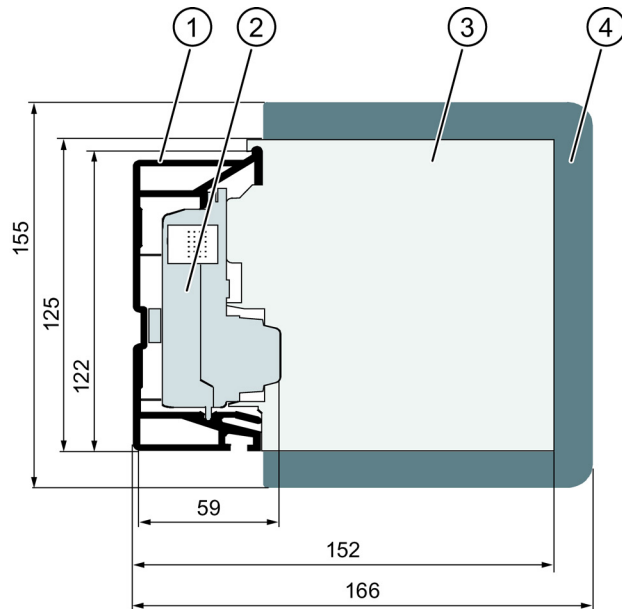

Figure B-2 Dimensional drawings SM 336; F-AI 6 x 0/4 ... 20mA HART and SM 326; F-DO 10 x DC 24V/2A PP

Dimensional drawing of a signal module with active bus module

The dimensional drawing (side view) below shows a signal module with active bus module for "hot-swap" functionality, the S7-300 module, and the Ex partition. These dimensions apply to all signal modules on the active backplane bus.



- ① Mounting rail with "insertion and removal" fixture
- ② Active bus module
- ③ S7-300 module
- ④ Ex partition

Figure B-3 Dimensional drawing of a signal module with active bus module

B.2 Safety protector [ID: 431504267]

Dimensional drawing of a safety protector

See the dimensional drawing of a safety protector below.

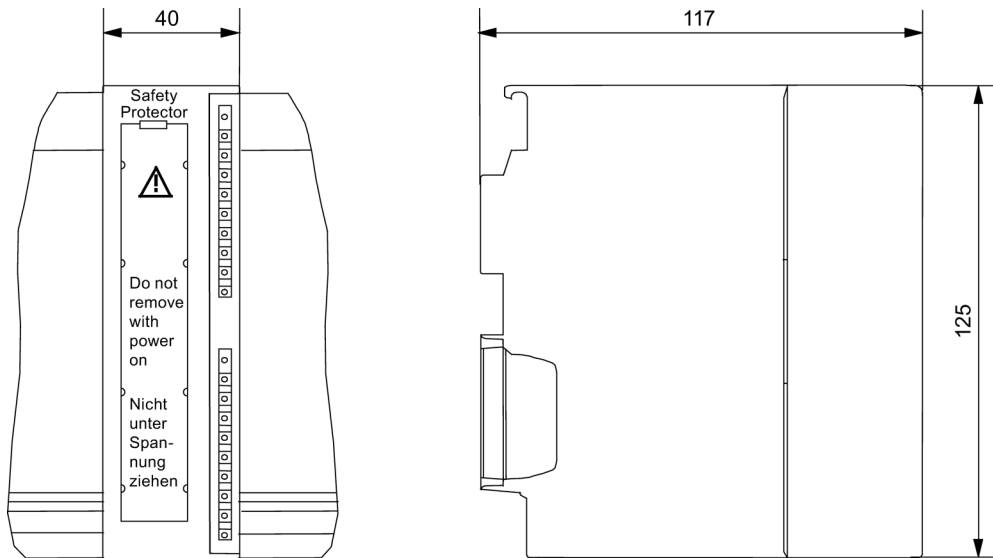

Figure B-4 Dimensions of the safety protector

Bus module for safety protector

See the dimensional drawing of a bus module for safety protectors below.

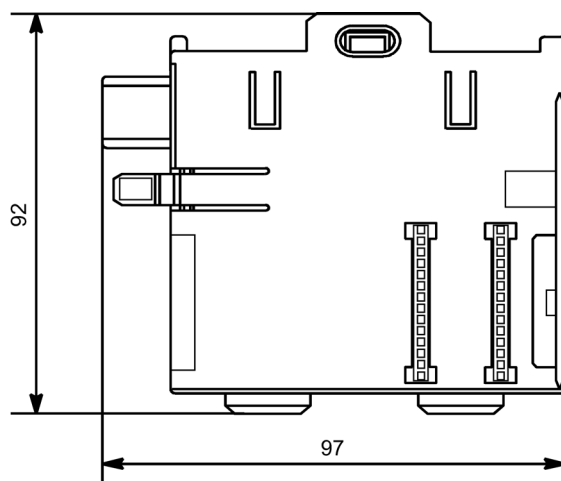

Figure B-5 Dimensional drawing of the bus module for safety protectors

Accessories and order numbers

C.1 Accessories and Order Numbers [ID: 431511819]

Accessories and order numbers

The table below lists the order numbers of fail-safe signal modules, of the safety protector, and of accessories for fail-safe signal modules.

Table C- 1 Accessories and order numbers

Component	Order number
SIMATIC PDM	
• SOFTWARE BASIC V6.0 (4 TAGS) FLOATING LICENSE	6ES7658-3AX06-0YA5
• SOFTWARE BASIC V6 (4 TAGS) RENTAL LICENSE	6ES7658-3AX06-0YA6
• SOFTWARE SINGLE POINT V6.0 (1 TAG) FLOATING LICENSE	6ES7658-3HX06-0YA5
• SOFTWARE SERVICE V6.0 (128 TAGS) FLOATING LICENSE	6ES7658-3JX06-0YA5
• SOFTWARE S7 V6.0 (128 TAGS) FLOATING LICENSE	6ES7658-3KX06-0YA5
• SOFTWARE PCS 7 V6.0 (128 TAGS) FLOATING LICENSE	6ES7658-3LX06-0YA5
Fail-safe signal modules	
• SM 326; DI 24 x DC 24V	6ES7326-1BK02-0AB0
• SM 326; DI 8 x NAMUR	6ES7326-1RF00-0AB0
• SM 326; DO 8 x DC 24V/2A PM	6ES7326-2BF41-0AB0
• SM 326; DO 10 x DC 24V/2A	6ES7326-2BF01-0AB0
• SM 326; F-DO 10 x DC 24V/2A PP	6ES7326-2BF10-0AB0
• SM 336; AI 6 x 13Bit	6ES7336-1HE00-0AB0
• SM 336; F-AI 6 x 0/4 ... 20 mA HART	6ES7336-4GE00-0AB0
Safety protector	6ES7195-7KF00-0XA0
Bus module for safety protector	6ES7195-7HG00-0XA0
Cable guide for SM 326; DI 8 5 NAMUR (5 units)	6ES7393-4AA10-0AA0
Labels	
• Yellow labeling strips (10 items)	6ES7392-2XX20-0AA0
• Yellow cover plates, transparent yellow (10 items)	6ES7392-2XY20-0AA0
Front connector, 20-pin	
• Screw connection system (1 unit)	6ES7392-1AJ00-0AA0

Component	Order number
• Screw connection system (100 units)	6ES7392-1AJ00-1AB0
• Spring-loaded terminal connection system (1 unit)	6ES7392-1BJ00-0AA0
• Spring-loaded terminal connection system (100 units)	6ES7392-1BJ00-1AB0
• Fast Connect connector (1 unit)	6ES7392-1CJ00-0AA0
Front connector, 40-pin	
• Screw connection system (1 unit)	6ES7392-1AM00-0AA0
• Screw connection system (100 units)	6ES7392-1AM00-1AB0
• Spring-loaded terminal connection system (1 unit)	6ES7392-1BM00-0AA0
• Spring-loaded terminal connection system (100 units)	6ES7392-1BM00-1AB0
• Fast Connect connector (1 unit)	6ES7392-1CM00-0AA0
Bus connector	6ES7390-0AA00-0AA0
Active bus module	
• Bus module BM IM/IM (...7HD) for redundancy with 2 x IM 153-2AA02 / -2AB01	6ES7195-7HD00-0XA0
• Bus module BM IM/IM (...7HD) for redundancy with 2 x IM 153-2Bx00 / -2Bxx1	6ES7195-7HD10-0XA0
• Bus module BM IM/IM (...7HD) Outdoor for redundancy with 2 x IM 153-2Bx00 / -2Bxx1	6ES7195-7HD80-0XA0
• Bus module BM PS/IM (...7HA) for power supply and IM 153	6ES7195-7HA00-0XA0
• Bus module 2 x 40 (...7HB) for one or two 40 mm wide S7-300 modules	6ES7195-7HB00-0XA0
• Bus module 1 x 80 (...7HB) for one 80 mm wide S7-300 module	6ES7195-7HC00-0XA0

Response times

D.1 Response Times [ID: 431782795]

Introduction

The next section shows the response times of fail-safe signal modules. The response times of fail-safe modules are included in the calculated response time of the F-system.

For information on the calculated response time of the F-system, refer to the Safety Engineering in SIMATIC S7

(<http://support.automation.siemens.com/WW/view/en/12490443>)system description.

The elements used in the formulae below are available in the technical data of the relevant module.

Response time definition

For fail-safe digital inputs: The response time represents the interval between a signal change at the digital input and reliable availability of the safety message frame on the backplane bus.

For fail-safe digital outputs: The response time represents the interval between an incoming safety message frame from the backplane bus and the signal change at the digital output.

For fail-safe analog inputs: The response time results from the number of channels/channel pairs, the response time per channel/channel pair, the basic response time and, in the case of SM 336; F-AI 6 x 0/4 ... 20 mA HART, also the configured smoothing.

Response time of SM 326; DI 8 x NAMUR

Calculation of the response time of SM 326; DI 8 x NAMUR (without active error and with active error):

Response time = internal signal preparation time + input delay

Example SM 326; DI 8 x NAMUR

Response time = 55 ms + 3 ms = 58 ms

An active error extends the response time by the amount of the assigned discrepancy time, if the "1oo2 evaluation" of the sensors was assigned.

Note

Calculate the maximum response time by inserting the maximum values derived from technical data of the fail-safe signal modules in the formula shown earlier.

Response time of SM 326; DO 10 x DC 24V/2A

Calculation of the response time of SM 326; DO 10 x DC 24V/2A (without active error and with active error):

Response time = internal signal preparation time + output delay

The output delay can always be ignored.

Example SM 326; DO 10 x DC 24V/2A in safety mode:

Response time = 24 ms + 0 ms = 24 ms

Note

Calculate the maximum response time by inserting the maximum values derived from technical data of the fail-safe signal modules in the formula shown earlier.

Maximum response time of SM 326; F-DO 10 x DC 24V/2A PP

Calculation of the response time of SM 326; F-DO 10 x DC 24V/2A PP (without active error and with active error):

Response time = 2 × internal preparation time + MAX{ max. read-back time dark test, max. light test time } + 10 ms

Example SM 326; F-DO 10 x DC 24V/2A PP in safety mode:

Response time = 2 × 8 ms + MAX{1 ms, 0.6 ms} + 10 ms = 27 ms

Note

Calculate the maximum response time by inserting the maximum values derived from technical data and the configuration of the fail-safe signal modules in the formula shown earlier.

Maximum response time of SM 326; DI 24 x DC 24V

Formula for calculating the maximum response time without active error:

$$\text{Maximum response time without active error} = T_{\max} + 3 \text{ ms}^* + 6 \text{ ms}^{**}$$

Input delay*

** Short-circuit test time = 2 x input delay

You configure the short-circuit test in *STEP 7* (see chapter "SM 326; DO 8 x DC 24V/2A PM (Page 133)").

Table D-1 SM 326; DI 24 x DC 24V: Internal signal preparation times

Evaluation of the sensors	Minimum internal signal preparation time T_{\min}	Maximum internal signal preparation time T_{\max}
1oo1 and 1oo2	6 ms	23 ms

Maximum response time when a fault occurs:

The following table shows the maximum response time of the SM 326; DI 24 x DC 24V when a fault occurs, depending on the parameter assignment in *STEP 7* and the evaluation of the sensors.

Table D-2 SM 326; DI 24 x DC 24V: Maximum response time when a fault occurs

Short-circuit test parameter	1oo1 evaluation	1oo2 evaluation*
Short-circuit test deactivated	31 ms	29 ms
Short-circuit test activated	31 ms	29 ms

* Response times with **1oo2 evaluation** also depend on the assigned behavior at discrepancy:
Provide 0 value: The times listed in the table apply.
Provide last valid value: The times listed in the table are extended by the assigned discrepancy time.

Maximum response time of SM 326; DO 8 x DC 24V/2A PM

The maximum response time of the SM 326; DO 8 x DC 24V/2A PM (with or without fault) is equivalent to the maximum internal processing time T_{\max} .

Minimum internal signal preparation time $T_{\min} = 4 \text{ ms}$

Maximum internal signal preparation time $T_{\max} = 14 \text{ ms}$

Response time of SM 336; AI 6 x 13Bit

Calculation of the response time (conversion time) of SM 336; AI 6 x 13Bit (with and without active fault) according to the following formula:

Response time = $N \times$ response time per channel + basic response time

Where N represents the number of activated channels

Example all channels connected ($N = 6$), interference frequency = 50 Hz:

Response time = $6 \times 50 \text{ ms} + 50 \text{ ms} = 350 \text{ ms}$

If an error occurred, the response time is extended by the assigned discrepancy time if "2 sensors" was assigned and the signal has no safe failure direction (or the assigned "standard value" does not conform with the safe failure direction).

Note

Calculate the maximum response time by inserting the maximum values derived from Technical data - SM 336; AI 6 x 13Bit (Page 235) of the SM 336; AI 6 x 13Bit in the formula shown earlier.

Response time of SM 336; F-AI 6 x 0/4 ... 20 mA HART

- Calculation of the response time (conversion time) of SM 336; F-AI 6 x 0/4 ... 20 mA HART with and without active fault according to the following formula:

Typical response time (without active fault) = Conversion cycle time × Smoothing

Typical response time (without active fault) = 2 × Conversion cycle time × Smoothing

Example

Fault frequency 50 Hz, Smoothing = 1 conversion cycle, 3 active channel pairs:

Max. response time (without active fault) = 2 × 125 ms × 1 = 250 ms

- If a discrepancy occurred during 1oo2 evaluation, the maximum response time is calculated according to the following formula:

Maximum response time (in case of discrepancy) = 2 × Conversion cycle time × Smoothing + Discrepancy time + 2 × Conversion cycle time

The discrepancy time is the configured discrepancy time.

Example

Fault frequency 50 Hz, Smoothing = 1 conversion cycle, discrepancy time = 2000 ms, 3 active channel pairs:

Maximum response time (in case of discrepancy) = 2 × 125 ms × 1 + 2000 ms + 2 × 125 ms = 2500 ms

- If a channel fault occurred, the maximum response time is calculated according to the following formula:

Maximum response time (in case of a channel fault) = 2 × Conversion cycle time

Example

Fault frequency 50 Hz, 3 active channel pairs:

Maximum response time (in case of a channel fault) = 2 × 125 ms = 250 ms

Note

You calculate the response time by using the values from Chapter "Technical Data - SM 336; F-AI 6 x 0/4 ... 20 mA HART (Page 287)" in the formulas indicated above.

Note on the calculation of response times

Note

Note that the Excel files for the calculation of maximum response times (s7fcotia.xls (<http://support.automation.siemens.com/WW/view/en/11669702/133100>) and s7ftimea.xls (<http://support.automation.siemens.com/WW/view/en/26091594/133100>)) included in the *S7 Distributed Safety* and *S7 F/FH Systems* options packages already support the calculation of an extended "maximum response time with active error" by the amount of the assigned discrepancy time.

Switching capacitive and inductive loads

[ID: 6443287307]

Switching capacitive loads

SM 326; DO 10 x DC 24V/2A, SM326; DO 8 x DC 24V/2A PM may generate a "short-circuit to L+ or output driver failure" error message if outputs without series diodes are interconnected with low-current loads with capacitive element. Reason: insufficient discharge of capacitance within the 1-ms readback time during self-test.

The figures below show a typical curve representing the correlation between load impedance and switchable load capacitance for a supply voltage of 24V DC.

Switching behavior SM 326; DO 10 x DC 24V/2A

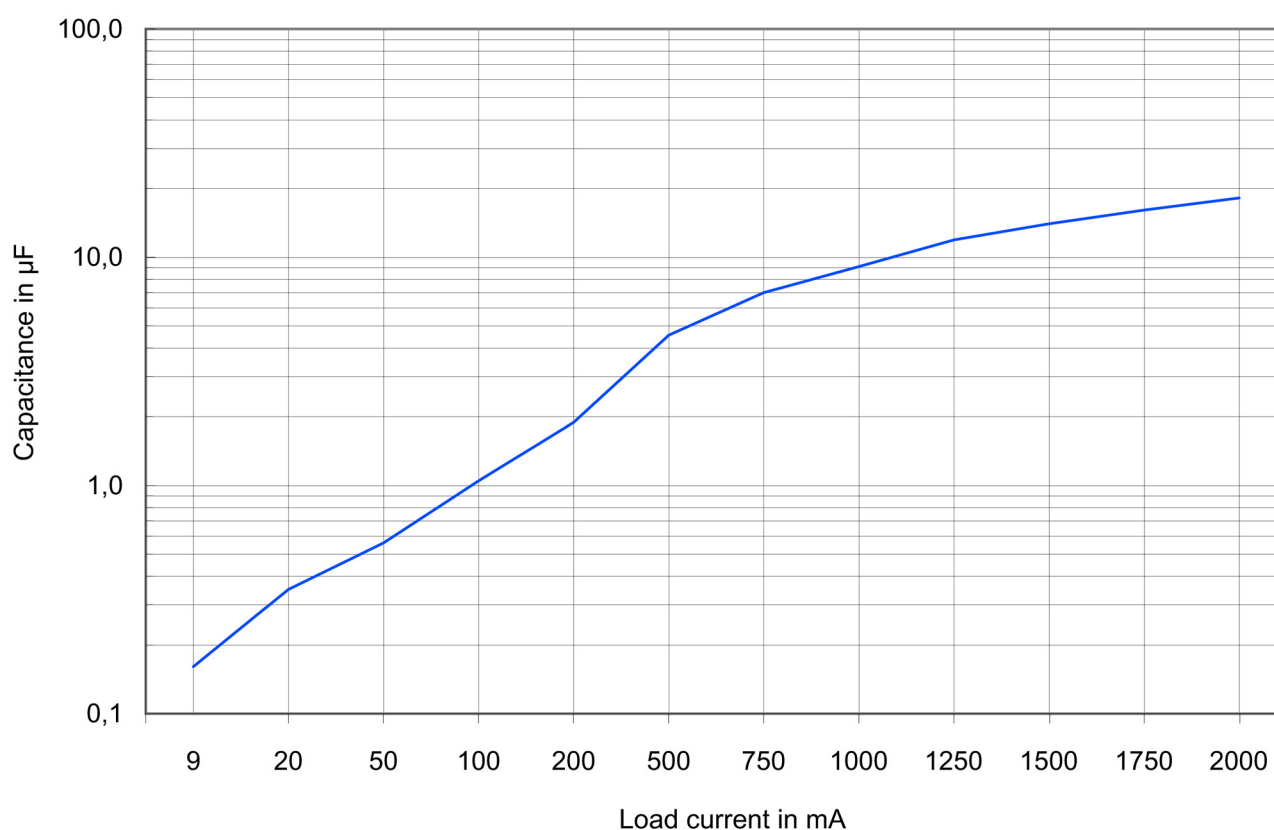

Figure E-1 Relationship between load resistance and switchable load capacitance for SM 326; DO 10 x DC 24V/2A

Remedy:

1. Determine the load current and the capacitance of the load.
2. Determine the operating point in the diagram above.
3. If the operating point lies above the curve, you must do one of the following:
 - Increase the load current by connecting a resistor in parallel until the new operating point is below the curve
 - Use the output with series diode

Switching behavior SM 326; F-DO 10 x DC 24V/2A PP

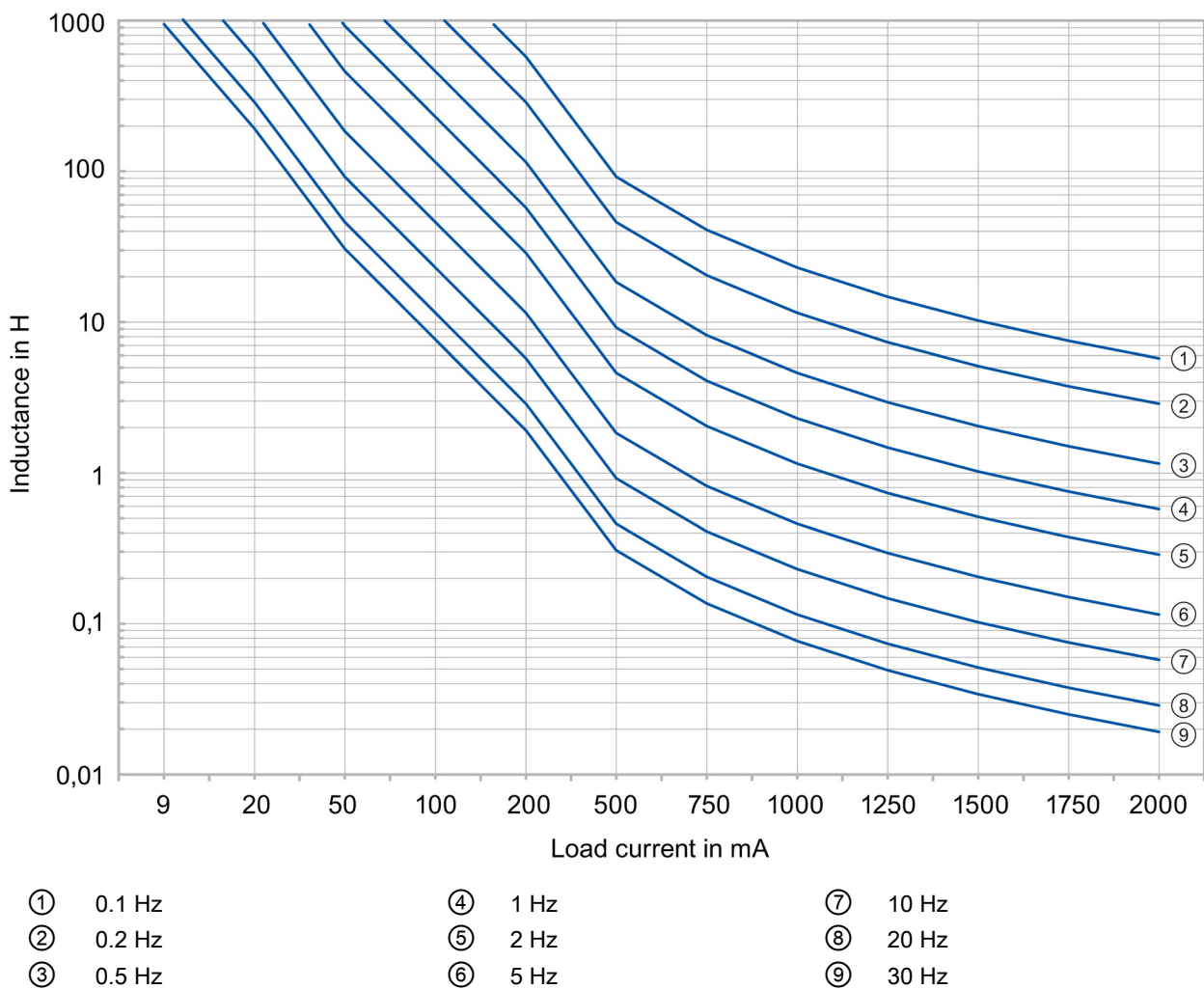
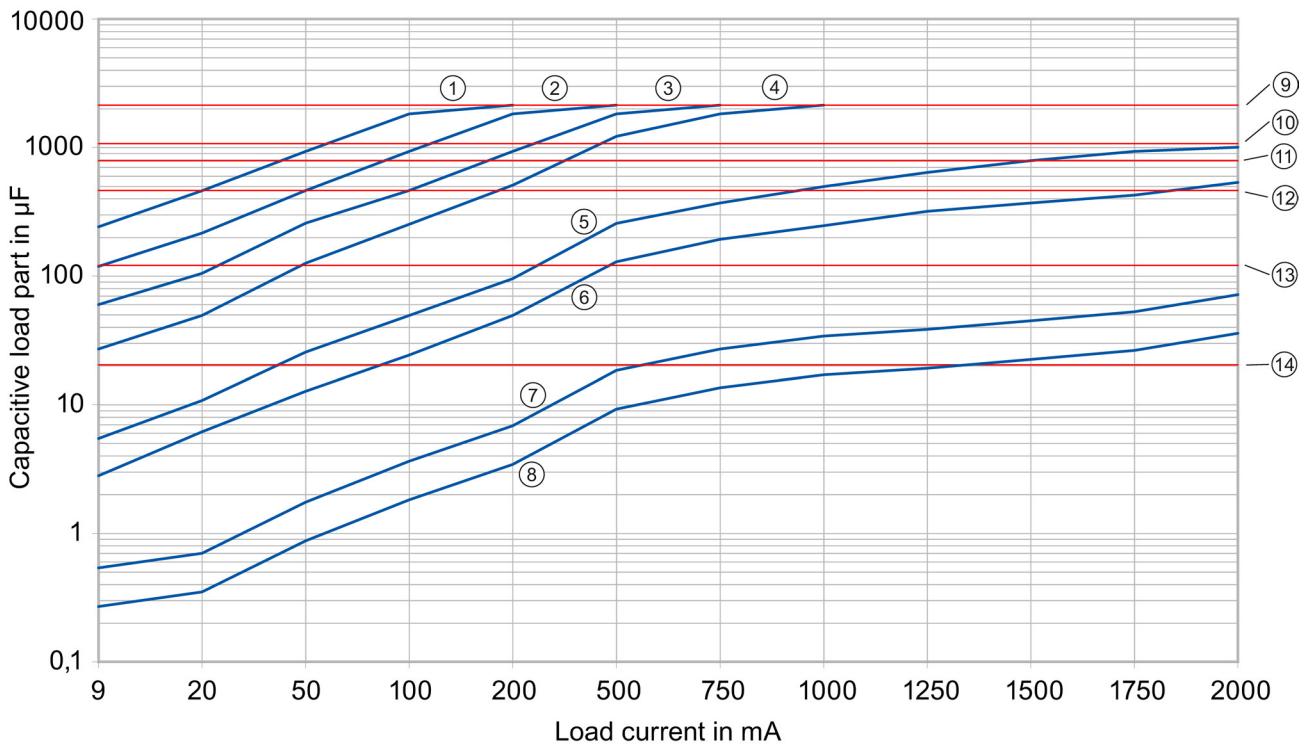

Figure E-2 Max. permitted inductive load depending on load current and switching frequency



Assigned max. read-back time for dark test:

① 400 ms	④ 50 ms	⑦ 1 ms
② 200 ms	⑤ 10 ms	⑧ 0,6 ms
③ 100 ms	⑥ 5 ms	

Assigned max. light test time:

⑨ Deactivated	⑪ 3 ms	⑬ 0,9 ms
⑩ 5 ms	⑫ 2 ms	⑭ 0,6 ms

Figure E-3 Max. permitted capacitive load depending on max. light test time and max. read-back time dark test

Glossary

1oo1 evaluation

Type of → sensor evaluation: In 1oo1 evaluation, the → sensor is not redundant and is connected via one channel to the module.

1oo2 evaluation

Type of → sensor evaluation: In 1oo2 evaluation, two input channels are occupied, either by one two-channel sensor or two one-channel sensors. The input signals are compared internally for equivalence or nonequivalence. Alternatively, the 1oo2 evaluation in *S7 F Systems* can be made with F-block F_1oo2AI.

2oo3 evaluation

Type of → sensor evaluation: In 2oo3 evaluation, three input channels are occupied by one-channel sensors. The input signals undergo a 2oo3 evaluation in the safety program with a F_2oo3AI block in *S7 F Systems*.

Acknowledgment time

Interval within which the → F-I/O acknowledges the sign-of-life signal output by the → F-CPU. The acknowledgment time is included in the calculation of the → monitoring time and → response time of the entire F-system.

Actuator

Denotes, for example, power relays or relay contactors for switching loads, or the actual load (for example, directly controlled solenoid valves).

Availability

Probability that a system is functional at a defined point in time. Can be enhanced by means of → redundancy (for example, by using redundant signal modules and/or multiple → sensors at the same measuring point).

Category

Category according to ISO 13849-1:2006 or EN ISO 13849-1:2008

The → fail-safe signal modules support up to category 4 when operated in safety mode.

Channel fault

Channel-specific fault such as wire break or short-circuit.

Channel number

Channel numbers are used to identify the I/O of a module and to assign channel-specific diagnostic messages.

Channel-selective passivation

When a → channel fault occurs, only the relevant channel is passivated in this passivation method. The channels of the affected channel group/all channels of the fail-safe signal module are passivated when a channel group fault/module fault is detected.

CiR

CiR = Configuration in RUN. System modification in RUN by means of CiR allows the configuration of units of an active system with distributed I/O. Process execution is interrupted for the duration of a brief, assignable period. The process inputs retain their last value during this period.

CiR is only possible in deactivated safety mode.

Configuring

Systematic arrangement of the signal modules (configuration)

CRC

Cyclic Redundancy Check → CRC signature check

CRC Signature

The process data in the safety message frame, the address correlations and the safety-relevant parameters are validated by means of a CRC signature in the safety message frame.

Dark period

Dark periods are generated in the course of shutdown tests and complete bit pattern tests. The fail-safe output module transfers test-specific zero signals to the active output. The output is then switched off briefly ("dark period"). A sufficiently slow → actuator does not respond to this signal and remains active.

Discrepancy analysis

Discrepancy analysis for equivalence or nonequivalence is used for fail-safe inputs in order to determine faults based on the time characteristic of two signals with the same functionality. Discrepancy analysis is initiated when different levels are detected for two associated input signals (for nonequivalence check: same level). On expiration of an assignable period (→ discrepancy time), a check is made to determine whether the difference (or, in the case of nonequivalence: the agreement) has been cleared. If not, a discrepancy error exists.

There are two types of discrepancy analysis for fail-safe input modules:

- → 1oo2 evaluation:

The discrepancy analysis is performed between the two input signals of the 1oo2 evaluation in the fail-safe input module.

- With redundant I/O (only S7 FH systems):

The discrepancy analysis is performed between the two input signals of the redundant input modules by the fail-safe driver blocks of the *S7 F/FH Systems* optional software.

Discrepancy time

Configurable time for the → discrepancy analysis. If the assigned discrepancy time is too long, the fault detection time and → fault reaction time are prolonged unnecessarily. If the assigned discrepancy time is too short, availability is reduced unnecessarily, as a discrepancy error which in actual fact does not exist is reported.

Fail-safe signal modules

S7-300 signal modules that support safety-oriented operation (in → safety mode) in *S7 Distributed Safety* or *S7 F/FH Systems*. These modules feature integrated → safety functions.

Fail-safe systems

Fail-safe systems (F-systems) remain in a safe state or immediately change to another safe state when specific failures are detected.

Fault reaction time

The maximum fault reaction time of an F-system denotes the interval between the occurrence of any fault and a reliable reaction at all corresponding fail-safe outputs. For the overall → F-System: The maximum fault reaction time defines the interval between the occurrence of any fault in any → F-I/O and a reliable reaction at the corresponding fail-safe output.

At inputs: The maximum fault reaction time defines the interval between the occurrence of the fault and the reliable reaction at the backplane bus.

For digital outputs: The maximum fault reaction time defines the interval between the occurrence of the fault and the reliable reaction at the digital output.

F-CPU

An F-CPU is a fail-safe central processing unit that is approved for operation in *S7 Distributed Safety/S7 F/FH Systems*. The F-copy license for *S7 F/FH Systems* allows users to operate the CPU as an F-CPU, that is, to execute a → safety program in this CPU. The F-copy license is not required for *S7 Distributed Safety*. The F-CPU can also execute a → default user program.

F-I/O

Collective name for fail-safe inputs and outputs that are available in *SIMATIC S7* for integration in the *S7 Distributed Safety* and *S7 F/FH Systems* F-systems. They comply to the standards IEC 61784-1 Ed3 CP 3/1 or IEC 61784-2 CP 3/5 and CP 3/6 and IEC 61158 types 5-10 and 6-10 and the PROFIsafe bus profile according to IEC 61784-3-3 Ed2.

Available I/O:

- ET 200eco fail-safe I/O module
- S7-300 fail-safe signal modules (F-SMs)
- ET 200S fail-safe modules
- Fail-safe DP standard slaves

Frequency shift keying (FSK)

Data modulation technique suitable for data transport over standard lines. Two audio frequencies are used in order to encode the binary "0" and "1" in the frequency range of 300 – 3000 Hz. In the → HART protocol, the FSK signal is transmitted over a current loop.

FSK

Frequency shift keying (FSK)

F-SM

→ Fail-safe signal modules

F-systems

→ fail-safe systems

HART

Highway Addressable Remote Transducer. HART is a registered trademark of the → HART Communication Foundation.

HART analog modules

Analog modules that can perform → HART communication in addition to their analog value. HART analog modules can be used as a → HART interface for HART field devices.

HART commands

The HART field device works as a HART device and is controlled by the master via HART commands. The master assigns the HART parameters or requests data in the form of → HART replies.

HART communication

Transmission of data between a master (e.g. HART analog module) and a HART device (→ HART field device) via the → HART protocol.

HART Communication Foundation

The HART Communication Foundation (HCF) was founded in 1993 to publish and further develop the HART protocol. HCF is a non-profit organization, which is financed by its members.

HART communicator

The HART communicator contains the original parameter assignment tool of Fisher-Rosemount LTd. for → HART field devices, and is connected directly to their terminals. The HART communicator is used to assign the HART parameters.

HART field device

Intelligent field device furnished with a → HART-compatible additional function that allows it to understand → HART communication.

HART interface

Part of a system that can be used to connect a → HART field device. The HART interface represents the master for the field device. However, the HART interface acts as a slave to the system and can be supplied from various masters on the system. For example, the → HART parameter assignment tool represents a master. Another master is the automation system itself.

HART parameter assignment tool

The HART parameter assignment tool is used for convenient assignment of the → HART parameters. It can be a → HART communicator or a parameter assignment tool integrated in the system, e.g., *SIMATIC PDM*.

HART parameters

HART parameters describe the assignable properties of → HART field devices that can be modified via the → HART protocol. A → HART parameter assignment tool is used to assign the parameters.

HART protocol

The → HART protocol is the industry standard for extended communication with → HART field devices. It includes → HART commands and → HART replies.

HART replies

The HART field device transmits data at the request of the master. These data are measurement results or manipulated variables or values of → HART parameters. A HART reply always contains a status information, i.e., the → HART status bytes.

HART signal

Analog signal on a current loop of 4 - 20 mA, with which the sine waves for the → HART protocol, 1200 Hz for binary "1" and 2200 Hz for binary "0", are modulated up using → frequency shift keying.

HART status byte

Status information that consists of the first and second status bytes of the → HART reply and that the HART field device uses to provide information regarding the → HART communication, the receipt of the → HART command and the device status.

HART transfer area

Area of data records that is specified in the HART analog modules for writing HART commands and reading HART replies. The HART transfer area consists of data records. A separate area of data records is assigned to each → client and is used by the → server to exchange data with the client.

HCF

→ HART Communication Foundation

IO Controller

-> PROFINET IO Controller

IO Device

-> PROFINET IO Device

Light period

Light periods develop in the course of complete bit pattern tests. The fail-safe output module returns test-specific "1" signals to the inactive output (when output signal = "0"). This briefly enables the output (= "light period"). A sufficiently slow actuator does not respond to this signal and remains deactivated.

M switch

Each fail-safe digital output of SM 326 DO 8 x DC 24V/2A PM consists of one DOx P switch (current source) and one DOx M switch (current sinking). The load is connected between the P and M switches. The two switches are always active in order to power the load.

Measuring location identification tag

Unique identifier for the measuring point, consisting of 8 characters. It is saved in the → HART field device and can be modified and read out via → HART commands.

Modem

A modem (MOdulator / DEModulator) is a device that converts binary digital signals to → frequency shift keying signals and vice versa. A modem does not encode any data, but converts the physical form of the signals.

Module fault

Module faults may be caused by external faults (for example, missing load voltage) or by internal faults (for example, processor failure). Internal faults always require module replacement.

Module redundancy

A module and a second identical module are operated in redundant mode in order to enhance availability.

Monodrop

In a monodrop communication system, a maximum of two devices are connected to the same transmission line, e.g., channel of the HART analog module and a → HART field device. The → HART protocol and the analog signal can be used simultaneously in this method.

The HART short address of the field device is 0.

MTA

Marshaled Termination Assemblies

Multidrop

Up to 15 field devices can be connected to a HART master in a multidrop communication system. Communication is exclusively via the → HART protocol, the analog signal cannot be used in this method.

The HART short address of the field device is between 1 and 15.

Nonequivalent sensor

A nonequivalent → sensor is a two-way switch that is connected (via two channels) to two inputs of an → F-I/O in → fail-safe systems (for → 1oo2 evaluation of sensor signals).

One-channel I/O

Configuration variant of *S7 Distributed Safety/S7 F/FH Systems* in → safety mode. → F CPU undo → F I/O are redundant. The F-I/O is no longer available when in error state.

One-channel switched I/O

Configuration variant of *S7 FH Systems* in → safety mode for enhancing availability. The → F-CPU is redundant, → F-I/O is not redundant; the system changes to the partner F-CPU when a fault is detected. The F-I/O may no longer be available when in error state.

P switch

→ M switch

Parameter assignment

Assigning parameters using PROFIBUS DP: Transfer of slave parameters from the DP master to the DP slave.

Parameter assignment of modules/submodules: Assigning the behavior of modules/submodules with the *STEP 7* configuration software.

Passivation

An → F-I/O sets the corresponding channel or all channels to → safe state when it detects a fault, that is, it passivates its channels. The F-I/O reports the fault to the → F-CPU.

If F-I/O inputs are passivated the → F-system returns fail-safe values to the → safety program instead of the process values set at the fail-safe inputs.

If F-I/O outputs are passivated the → F-system returns fail-safe values to the fail-safe outputs ("0") instead of the output values returned by the → safety program.

PG

Programming device Compact PC designed for use in industry. A programming device is fully equipped for programming SIMATIC automation systems.

Process image

The process image is a part of CPU system memory. The signal states of the input modules are transferred to the process image of inputs at the start of cyclic program execution. The process image of the outputs is transferred to the output modules as a signal state at the end of the cyclic program execution.

Process safety time

The process safety represents the interval during which a process may be allowed to continue without intervention, without developing any risk to life and limb of operating personnel or damage to the environment.

Any type of F-system process control is tolerated within the process safety time, that is, the process can be controlled incorrectly or not at all. The process safety time of a process depends on the process type and must be determined individually.

PROFIBUS

PROcess FieId BUS, German process and fieldbus standard defined by the standard IEC 61784-1 Ed3 CP 3/1. It defines the functional, electrical and mechanical properties of a bit-serial fieldbus system.

PROFIBUS is available for the protocols DP (= distributed I/O) and PA (= process automation).

PROFINET

Within the framework of Totally Integrated Automation (TIA), PROFINET is the consistent continuation of:

PROFIBUS DP, the established fieldbus, and

- Industrial Ethernet, the communication bus for the cell level.
- The experiences of both systems were and will be integrated in PROFINET.

PROFINET as Ethernet-based automation standard from PROFIBUS International (formerly PROFIBUS Nutzerorganisation e.V.) defines a communication, automation and engineering model across manufacturers. PROFINET is defined in the standards IEC 61784-2 CP 3/5 and CP 3/6 and IEC 61158 types 5-10 and 6-10.

PROFINET IO

Within the framework of PROFINET, PROFINET IO is a communication concept for the implementation of modular, distributed applications.

PROFINET IO allows you to create automation solutions familiar from PROFIBUS.

PROFINET IO is implemented based on both the PROFINET standard for automation devices and the STEP 7 engineering tool. This means that you have the same application view in STEP 7, regardless of whether you are configuring PROFINET or PROFIBUS devices. Programming your user program is essentially the same for PROFINET IO and PROFIBUS DP if you use the expanded blocks and system status lists for PROFINET IO.

PROFINET IO Device

A PROFINET IO device is a decentralized field device that is assigned to one of the IO controllers (e.g., remote IO, valve terminals, frequency converters, switches).

PROFINET IO Controller

A PROFINET IO controller is a device that is addressed via the connected IO device. That is: that the IO controller exchanges input and output signals with assigned field devices. The IO controller is often the controller on which the automation program runs.

PROFIsafe

Safety-related PROFIBUS DP/PA and PROFINET IO bus profile according to IEC 61784-3-3 Ed2 for communication between the → safety program and the → F-I/O in an → F-system.

PROFIsafe address

Each → F-I/O is assigned a PROFIsafe address. You must configure the PROFIsafe address in *STEP 7 HW Config* and set it on the F-I/O using a switch.

PROFIsafe monitoring time

Monitoring time for safety-oriented communication between the F-CPU and F-I/O.

Proof-test interval

The faultless state of a component must be verified on expiration of this specific time, that is, it must be replaced with an unused component unless proven faultless.

Redundancy, availability enhancing

Multiple instances of components with the focus set on maintaining component functionality even in the event of hardware faults.

Redundancy, safety enhancing

Multiple availability of components with the focus set on exposing hardware faults based on comparison; for example, → 1oo2 evaluation in → fail-safe signal modules.

Redundant switched I/O

Configuration variant of S7 FH Systems in → safety mode for enhancing availability. → F-CPU, PROFIBUS DP, and → F-I/O are redundant. The F-I/O may no longer be available when in error state.

Reintegration

After a fault has been eliminated, a reintegration (depassivation) of the → F-I/O is required. The reintegration (changeover from fail-safe values to process values) occurs automatically or, alternatively, after user acknowledgment in the safety program.

Following reintegration of an F-I/O with inputs, the process values pending at the fail-safe inputs are provided to the → safety program again. In the case of an F-I/O with outputs, the → F-system transfers the output values provided in the safety program to the fail-safe outputs again.

Response time

Denotes the interval between the detection of an input signal and the change of its associated output signal.

The actual response time lies between a minimum and maximum response time. Allowances must be made in the system configuration for the longest expected response time.

For fail-safe inputs: The response time represents the interval between a signal change at the input and the reliable availability of the → safety message frame on the backplane bus.

For fail-safe digital outputs: The response time represents the interval between an incoming safety message frame from the backplane bus and the signal change at the digital output.

For fail-safe analog inputs: The response time results from the number of channels/channel pairs, the response time per channel/channel pair, the basic response time and, in the case of SM 336; F-AI 6 x 0/4 ... 20 mA HART, also the configured smoothing.

Safe state

The existence of a safe state at all process variables forms the basic principle of the safety concept in fail-safe systems. A "0" value represents the safe state at digital signal modules, for example.

Safety function

Integrated mechanism of the → F-CPU and → F-I/O that enables operation in → *S7 Distributed Safety* or *S7 F/FH Systems* fail-safe systems.

According to IEC 61508:2000: Function implemented by means of a safety system for maintaining or recovering the safe state of a system when specific faults are detected.

Safety Integrity Level

Safety Integrity Level (SIL) according to IEC 61508:2000. The higher the Safety Integrity Level, the more rigid the measures for prevention of systematic faults and for management of systematic faults and hardware failures.

The → fail-safe signal modules support Safety Integrity Level up to SIL 3 when operated in in safety mode.

Safety message frame

In safety mode, data are transferred between an → F-CPU and a → fail-safe signal module in a safety message frame.

Safety mode

Operating mode of → F-I/O which supports → safety-related communication using → safety message frames. → ET 200S fail-safe modules are dedicated to operation in safety mode. → S7-300 F-SMs (except F-AI 6 x 0/4 ... 20 mA HART) can be used in → standard mode or safety mode.

Safety program

Safety-related user program

Safety-related communication

Communication for the exchange of fail-safe data

Sensor

Sensors are used for accurate detection of digital and analog signals as well as routes, positions, velocities, rotational speeds, masses, etc.

Sensor evaluation

There are two types of sensor evaluation:

- → 1oo1 evaluation – sensor signal is read in once
- → 1oo2 evaluation - sensor signal is read twice by the same module and compared within the module or, in S7 F Systems, using F-block F_1oo2AI.
- → 2oo3 evaluation - sensor signal is compared in S7 F Systems using F-block F_2oo3AI.

Standard mode

F-I/O mode of operation which does not support → safety-oriented communication by means of → safety message frames. Supports only standard communication.

S7-300 F-SMs (except F-AI 6 x 0/4 ... 20 mA HART) can be used in standard mode or → safety mode.

Static parameters

Can only be set when the CPU is in STOP, and cannot be changed dynamically by the active user program by calling SFCs (system function).

Switch

PROFIBUS is a linear network. Communication participants are connected by a passive line: the bus.

The Industrial Ethernet, on the other hand, consists of point-to-point connections: each communication participant is connected exactly and directly to one other communication participant.

If a communication participant is connected with several other communication participants, then this communication participant is connected to the port of an active net component: the switch. Other communication participants (also switches) can now be connected to the other ports of the switch. The connection between a communication participant and the switch remains a point-to-point connection.

This means a switch regenerates and distributes the signals it receives. The switch "learns" the Ethernet address(es) of a connected PROFINET device or other switches and forwards only those signals that are intended for the connected PROFINET device or the connected switch.

A switch has a certain number of ports. Connect only one PROFINET device or another switch to each port.

Thread length

Air gap and creepage distance (air gap = shortest distance between two components in air. Creepage distance in air = shortest distance in air between two conductive parts along the surface of an insulating material)

Index

"

"Provide last valid value", 77

1

1oo2 evaluation, 34

A

Accessories, 341

Actuator

Additional requirements, 52

Requirements, 50

Address

PROFIsafe, 37, 42

Address assignment

SM 326, DI 24 x DC 24V, 79

Address assignment in standard and safety mode, 33

Address assignment of user data, 33

Address space

Permissible, 35

Address switch, 38

For PROFIsafe addresses, 42

Setting, 39, 42

Addressing

Of the channels in standard mode, 35

Analog input module SM 336 AI 6 x 13Bit

Measured value resolution, 195

Analog input module SM 336; F-AI 6 x 0/4 ... 20 mA

HART

Measured value resolution,

Analog value representation

Measured value range, 323

Analog value representation of SM 336; AI 6 x 13Bit

Measured value range,

Analog value representation of SM 336; F-AI 6 x 0/4 ...
20 mA HART

Measured value range,

Approval

FM, 62

UL, 62

Approvals, 4

Assigning parameters, 28

Availability

depending on the F-I/O used, 22

Enhanced, 27

B

Basic knowledge

Required, 3

C

Cable guide, 112, 115

Capacitive loads

Switching, 349

Categories 3 and 4, 16

Category, 22

Causes of the problem

at SM 326, DI 24 x DC 24V, 106

at SM 326, DO 8 x DC 24V/2A PM, 142

for SM 326, DI 8 x NAMUR, 128

SM 336, AI 6 x 13Bit, 233

with SM 326, DO 10 x DC 24V/2A, 161

with SM 326, F-DO 10 x DC 24V/2A PP, 187

CE approval, 4

CE mark, 61

Central configuration, 19

Changes

compared to the previous version, 3

Changes in the manual, 3

Checks

HART reply, 317

CiR, 26, 79

Client, 314

Transfer area,

Commands

HART, 304

Commissioning

of fail-safe signal modules, 17

Configuration

Central, 19

Distributed, 19

Redundant, 44

Configuration in RUN, 79

Configuration in RUN (CiR), 26

Configuration variant

Depending on availability, 22

In safety mode, 21

In standard mode, 20

Configuring, 26

Conventions
applied to this manual, 6

CPU
Approved, 20, 21

Cross circuit
Prevention, 138

D

Dark period, 52

Dark period suppression, 159, 179

Data record format

Diagnostics of the HART analog module, 314

HART analog module, 312

HART command, 315

HART communication, 314

HART reply, 316

Parameter data records for HART,

Data records 0 and 1

Diagnostics data, 328

Degree of protection, 74

Degree of protection IP 20, 74

Diagnostic interrupt, 59

Assigning parameters, 59

Diagnostic messages

and corrective measures, 59

in STEP 7, 59

SM 326, DI 24 x DC 24V, 105

SM 326, DI 8 x NAMUR, 127

SM 326, DO 10 x DC 24V/2A, 160

SM 326, DO 8 x DC 24V/2A PM, 140

SM 326, F-DO 10 x DC 24V/2A PP, 186

SM 336, AI 6 x 13Bit, 232

SM 336; AI 6 x 0/4 ... 20 mA HART,

Diagnostics buffer, 54

Diagnostics data, 328

Byte 7 for SM 326; DI 8 x NAMUR,

Byte 7 for SM 326; DO 8 x DC 24V/2A PM,

Byte 7 for SM 336; AI 6 x 13Bit,

Byte 7 to 9 for SM 326, DI 24 x DC 24V, 331

Bytes 0 and 1, 328

Bytes 2 and 3, 329

Bytes 4 to 6, 330

Bytes 7 and 8 for SM 326, DO 10 x DC 24V/2A, 333

Bytes 7 to 28 with SM 326, F-DO 10 x DC 24V/2A

PP, 334

Reading, 327

Signal modules, 327

Structure and contents, 328

with SM 336; F-AI 6 x 0/4 ... 20mA HART,

Diagnostics functions, 58

Diagnostics LEDs, 59

Diagnostics of the HART analog module

Data record format, 314

Diagnostics using the LED display, 58

Digital modules, 75

Dimensional drawing of a safety protector, 340

Dimensional drawing of the bus module for safety protectors, 340

Dimensional drawing of the signal module, 337

DIP switch, 38

Discrepancy analysis, 76

Discrepancy behavior, 76

Distributed configuration, 19

Documentation

Additional, 4

Duration of sensor signals

Requirements, 51

E

Electromagnetic compatibility, 66

EMC, 66

EMC Directive, 70

Enhanced availability, 27

Enhancement of availability, 16

Entering

HART parameters, 306

Environmental conditions, 72

Mechanical, 72

Evaluating diagnostics data, 58

Example

HART parameters, 304

F

F Configuration Pack, 25

F_destination_address, 37

Assigning, 41

Fail-safe automation system, 13

Fail-safe signal module, 13

Fail-safe value, 53

Fault reactions, 53

Fields of application, 65

FM

Approval, 62

Front connectors, 48

F-SM, 13

F-system, 13

Sample configuration, 15

G

- General technical data, 61
- Group diagnostics, 56
- Group fault
 - HART, 317
- Guide
 - through the manual, 6

H

- H/F Competence Center, 7
- HART
 - Commands, 304
 - Group fault, 317
 - Parameters, 304
 - Protocol error, 318
 - System environment for using HART, 306
 - Using, 305
- HART analog module
 - Access by means of SIMATIC PDM, 307
 - Transparent message data, 307
 - User data, 312
- HART command, 314
 - Data record format, 315
- HART communication, 312
 - Data record format, 314
 - Rule, 314
- HART parameters
 - entering, 306
 - Example, 304
- HART reply, 304, 314
 - Checks, 317
 - Data record format, 316
 - Processing status, 315
- HART signal
 - superimposed, 303
- HART status bytes, 317
- Hazardous Area, 112

I

- I&M data, 31
- IE/PB Link, 18
- IEC 1131, 64
- Input area
 - User data, 320
- Input delay, 345
- Insertion/removal, 49
- Interference
 - Pulse-shaped, 66, 67
 - Sinusoidal, 69

- IP 20, 74
- Isolation test, 74

K

- Keep last valid value, 15, 16, 55, 57, 179

L

- Loads, capacitive
 - Switching, 349
- Loads, inductive
 - Switching, 349
- Logical base address, 38

M

- Manual
 - Contents, 6
- Module start address, 37, 38

N

- Namur sensors, 50

O

- Operating conditions, 72
- Order numbers, 3, 341
- Output of fail-safe values, 53, 55
- Overvoltage protection, 324

P

- Parameter data records for HART
 - Data record format, 319
- Parameters, 28
 - HART, 304
- Passivation, 54
- Power supplies, 47
- PROFINET IO, 18
 - Network topology, 18
- PROFIsafe
 - Address, 37, 42
 - Assigning addresses, 41
- Protection class, 74
- Protective extra-low voltage
 - Protective, 46
- Protocol error

- HART, 318
- Provide 0 value, 77
- Pulse-shaped interference, 66, 67
- Purpose of this manual, 3

R

- Rated voltages, 74
- Recycling and disposal, 7
- Redundant configuration, 44, 70
- Redundant I/O devices, 16, 27
- Redundant switched I/O, 22
- References
 - Additional, 4
- Reintegration, 55
- Replacing modules, 49
- Requirement class, 16, 22
- Requirements
 - Software, 25
- Response time
 - Fail-safe analog input modules, 346
 - Fail-safe digital input modules, 343
- RF interference
 - Emission of, 70
- Rule
 - HART communication, 314

S

- Safe state, 13, 54
- Safety extra-low voltage (SELV), 46
- Safety Integrity Level, 16, 22, 50
- Safety mode, 15, 16, 42
 - Replacing modules, 49, 324
 - Setting, 38, 41
- Safety protector, 22
 - Block diagram, 322
 - Configuration in ET 200M/S7-300, 323
 - Front view, 322
 - Order number, 321
 - Technical data, 326
- Scope
 - Of this manual, 3
- Sensor
 - Requirements, 50
- Sensor signal
 - Duration requirements, 51
- Sensor supply
 - internal, 95
- Service & Support
 - on the Internet, 8

SFC

- Data record format, 313
- Reading diagnostics data, 327
- Shipping and storage conditions, 71
- Short-circuit test, 345
- Signal module
 - Diagnostics data, 327
 - Fail-safe, 13
- SIL 2, SIL 3
 - Requirement classes, 16
 - Safety Integrity Levels (SIL), 16
- Single-channel I/O, 22
- Single-channel switched I/O, 22
- Sinusoidal interference, 69
- SM 326, DI 24 x DC 24V
 - Applications, 84
 - Causes of the problem and corrective measures, 106
 - Channel numbers,
 - Diagnostic messages, 105
 - External sensor supply, 83
 - Front view, 80
 - Internal sensor supply, 95
 - Order number, 78
 - Parameters, 99
 - Properties, 78
 - Short-circuit to M and L+,
 - Technical specifications, 108, 130
 - Wiring and block diagram, 82
- SM 326, DI 8 x NAMUR
 - Address assignment,
 - Causes of the problem and corrective measures, 128
 - Channel numbers, 114
 - Diagnostic messages, 127
 - Front view, 113
 - Order number, 111
 - Properties, 111
 - Sensors supported, 113
 - Technical specifications, 130
 - Wiring and block diagram, 114
- SM 326, DO 10 x DC 24V/2A
 - Causes of the problem and corrective measures, 161
 - Channel numbers, 151
 - Diagnostic messages, 160
 - Order number, 148
 - Properties, 148
 - Technical specifications, 166
 - Wiring and block diagram, 151
- SM 326, DO 8 x DC 24V/2A PM
 - Address assignment, 134

- Applications, 137
- Causes of the problem and corrective measures, 142
- Channel numbers, 136
- Diagnostic messages, 140
- Front view, 135
- Order number, 133
- Properties, 133
- Technical specifications, 145
- Wiring and block diagram, 136
- SM 326, F-DO 10 x DC 24V/2A
 - Technical specifications, 190
- SM 326, F-DO 10 x DC 24V/2A PP
 - Causes of the problem and corrective measures, 187
 - Channel numbers, 173
 - Diagnostic messages, 186
 - Order number, 170
 - Properties, 170
 - Wiring and block diagram, 173
- SM 336, AI 6 x 13Bit, 235
 - Address assignment, 197
 - Causes of the problem and corrective measures, 233
 - Channel numbers, 198
 - Diagnostic messages, 232
 - External sensor supply, 199
 - Front view, 197
 - Order number, 196
 - Properties, 196
 - Wiring and block diagram, 198
- SM 336; AI 6 x 0/4 ... 20 mA HART
 - Diagnostic messages,
- SM 336; F-AI 6 x 0/4 ... 20 mA HART
 - Address assignment,
 - Causes of the problem and corrective measures,
 - Channel numbers,
 - External sensor supply,
 - Front view,
 - Order number,
 - Properties,
 - Wiring and block diagram,
- Smoothing of analog input values, 293
- Software requirements, 25
- Standard mode
 - Channel addressing, 35
- STEP 7, 25
- Structure and contents
 - Diagnostics data, 328
- Support
 - Additional, 7
- Switching capacitive loads, 349

- Switching of Inductive Loads, 349
- System environment
 - for using HART, 306

T

- Technical data
 - General, 61
 - Safety protector, 326
- Technical specifications
 - SM 326, DI 24 x DC 24V, 108
 - SM 326, DI 8 x NAMUR, 130
 - SM 326, DO 10 x DC 24V/2A, 166
 - SM 326, DO 8 x DC 24V/2A PM, 145, 166
 - SM 326, F-DO 10 x DC 24V/2A, 190
 - SM 336, AI 6 x 13Bit, 235
 - SM 336; F-AI 6 x 0/4 ... 20 mA HART,
- Technical Support, 7
- Test voltages, 74
- Thread length, 118
- Training Centers, 7
- Transducers
 - Analog input module, 200, 246
- Transfer area
 - Client, 314
- Transparent message data, 307
- TÜV certificate, 65

U

- UL
 - Approval, 62
- Underflow, 195, 240
- User data
 - HART analog module, 312
 - Input area, 320
- Using
 - HART analog module, 305

V

- Vibration, 72
- Voltages
 - Rated, 74

W

- Wire break, 195, 240
- Wiring, 48

