

SIEMENS

SIMATIC

S7-300 Programmable Controller Module Specifications

Reference Manual

This manual is part of the documentation package
with the order numbers:
Programmable Controller S7-300:
6ES7398-8FA10-8BA0

ET 200M Distributed I/O Device:
6ES7153-1AA00-8BA0

Edition 11/2002
A5E00105505-02

Preface, Contents	1
General Technical Specifications	2
Power Supply Modules	3
Digital Modules	4
Analog Modules	5
Other Signal Modules	6
Interface Modules	7
RS 485 Repeater	8
SIMATIC TOP connect and SIMATIC TOP connect TPA	
Appendix	
Parameter Sets for Signal Modules	A
Diagnostics Data of Signal Modules	B
Dimension Drawings	C
Spare Parts and Accessories for S7-300 Modules	D
Guidelines for Handling Electrostatic Sensitive Devices (ESD)	E
List of Abbreviations	F
Glossary, Index	

Safety Guidelines

This manual contains notices intended to ensure personal safety, as well as to protect the products and connected equipment against damage. These notices are highlighted by the symbols shown below and graded according to severity by the following texts:



Danger

indicates that death, severe personal injury or substantial property damage will result if proper precautions are not taken.



Warning

indicates that death, severe personal injury or substantial property damage can result if proper precautions are not taken.



Caution

indicates that minor personal injury can result if proper precautions are not taken.

Caution

indicates that property damage can result if proper precautions are not taken.

Notice

draws your attention to particularly important information on the product, handling the product, or to a particular part of the documentation.

Qualified Personnel

Only **qualified personnel** should be allowed to install and work on this equipment. Qualified persons are defined as persons who are authorized to commission, to ground and to tag circuits, equipment, and systems in accordance with established safety practices and standards.

Correct Usage

Note the following:



Warning

This device and its components may only be used for the applications described in the catalog or the technical description, and only in connection with devices or components from other manufacturers which have been approved or recommended by Siemens.

This product can only function correctly and safely if it is transported, stored, set up, and installed correctly, and operated and maintained as recommended.

Trademarks

SIMATIC®, SIMATIC HMI® and SIMATIC NET® are registered trademarks of SIEMENS AG.

Copyright © Siemens AG 1998–2002 All rights reserved

The reproduction, transmission or use of this document or its contents is not permitted without express written authority. Offenders will be liable for damages. All rights, including rights created by patent grant or registration of a utility model or design, are reserved.

Siemens AG
Bereich Automatisierungs- und Antriebstechnik
Geschäftsgebiet Industrie-Automatisierungssysteme
Postfach 4848, D- 90327 Nuernberg

Siemens Aktiengesellschaft

Disclaim of Liability

We have checked the contents of this manual for agreement with the hardware and software described. Since deviations cannot be precluded entirely, we cannot guarantee full agreement. However, the data in this manual are reviewed regularly and any necessary corrections included in subsequent editions. Suggestions for improvement are welcomed.

© Siemens AG 1998–2002
Technical data subject to change.

A5E00105505-02



Preface

Purpose of the manual

The information contained in this manual will enable you to look up operator actions, function descriptions and the technical specifications of the signal modules, power supply modules and interface modules of the S7-300.

How to configure, assemble and wire these modules in an S7-300 or ET 200M system is described in the installation manuals for each system.

Required basic knowledge

To understand this manual, it is necessary to have a general knowledge of automation and programmable logic controllers.

Scope of this manual

The present documentation package contains reference manuals for all the modules current at the time the manuals were published.

We reserve the right to enclose a product information leaflet containing up-to-date information on the module with new modules and modules with a new product version.

Changes compared with the previous version

Compared to the previous version, of the "Module Data" reference manual, the following chapters and appendices have been thoroughly revised and new modules added, as necessary:

- Preface
- Chapter 1 "General Technical Specifications"
- Chapter 3 "Digital Modules",
- Chapter 4 "Analog Modules"
- Appendix A "Signal Module Parameter Sets"
- Glossary

Note: The previous version of this "Module Data" reference manual can be recognized by the number in the footer: A5E00105505-01.

The current number is: A5E00105505-02.

Approbations

Refer to Section 1.1 Standards and approvals.

CE Approval

Refer to Section 1.1 Standards and approvals.

Identification for Australia (C-Tick-Mark)















Refer to Section 1.1 Standards and approvals.

Standards



Refer to Section 1.1 Standards and approvals.

How the manual fits in

S7-300

<p>"CPU Data" reference manual</p> <p> "CPU Data CPU 312 IFM to 318-2 DP"</p> <p> "CPU Data CPU 31xC and CPU 31x"</p>	<p>Description of operation, functions and technical specifications of the CPU.</p>
<p>"Technological Functions" manual</p> <p> Manual</p> <p> Examples</p>	<p>Description of the individual technological functions:</p> <ul style="list-style-type: none"> • Positioning • Counting • Point-to-point connection • Rules <p>The CD contains examples for the technological functions.</p>
<p>Installation manual</p> <p> Manual</p>	<p>Description of configuration, installation, wiring, networking and commissioning of an S7-300.</p>
<p>"Module data" reference manual</p> <p> Reference Manual</p> <p style="writing-mode: vertical-rl; transform: rotate(180deg);">You are reading this manual</p>	<p>Descriptions of functions and technical specifications of signal modules, power supply modules and interface modules.</p>
<p>Instruction List</p> <p> "CPU data CPUs 312 IFM to 318-2 DP"</p> <p> "CPU Data CPU 31xC and CPU 31x"</p>	<p>The instruction set lists of the CPUs and their execution times.</p> <p>A list of executable blocks (OBs/SFCs/SFBs) and their execution times.</p>
<p>Getting Started</p> <p> "CPU 31xC: Positioning with analog output"</p> <p> "CPU 31xC: Positioning with digital outputs"</p> <p> "CPU 31xC: Counting"</p> <p> "CPU 31xC: Point-to-point connection"</p> <p> "CPU 31xC: Rules"</p> <p> "CPU 31xC: Commissioning"</p> <p> "CPU 31x: Commissioning"</p>	<p>Getting Started documents use a concrete example to guide you through the individual commissioning steps until you have a functioning application.</p>

ET 200M

<p>"Distributed Peripheral" manual</p> <p> "Manual"</p>	<p>Description of configuration, assembly, wiring.</p>
<p>Reference Manual</p> <p>"Signal modules for process automation"</p> <p> "Reference Manual"</p>	<p>Description of use in process automation, parameterization with SIMATIC PDM, digital input modules, digital output modules.</p>
<p>"Module data" reference manual</p> <p> Reference Manual</p> <p style="writing-mode: vertical-rl; transform: rotate(180deg);">You are reading this manual</p>	<p>Descriptions of functions and technical specifications of signal modules, power supply modules and interface modules.</p>

Navigation

To help you find special information quickly, the manual contains the following access aids:

- At the start of the manual you will find a complete table of contents and a list of the diagrams and tables that appear in the manual.
- An overview of the contents of each section is provided in the left column on each page of each chapter.
- You will find a glossary in the appendix at the end of the manual. The glossary contains definitions of the main technical terms used in the manual.
- At the end of the manual you will find a comprehensive index which gives you fast access to the information you need.

Recycling and disposal

Because of its low-emission equipment, it is possible to recycle the S7-300. For ecologically harmless recycling and disposal of your old device, contact a certificated disposal service for electronic scrap.

Additional support

Please contact your local Siemens representative if you have any queries about the products described in this manual.

<http://www.ad.siemens.com/automation/partner>

Training center

We offer a range of relevant courses to help you to get started with the SIMATIC S7 programmable controller. Please contact your local training center or the central training center in

Nuremberg, D 90327 Germany.

Phone: +49 (911) 895-3200.

Internet: <http://www.sitrain.com>

A&D Technical Support

Contact at any time of the day throughout the world:

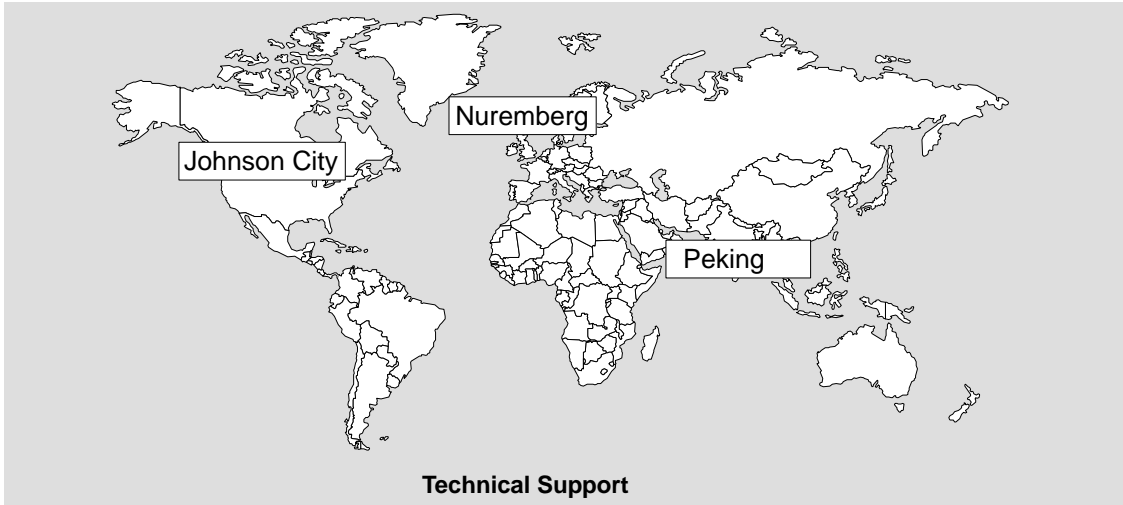

<p>Worldwide (Nuremberg) Technical Support</p> <p>Loc. time: 0:00 to 24:00 / 365 days Phone: +49 (0) 180 5050-222 Fax: +49 (0) 180 5050-223 E-mail: adsupport@siemens.com GMT: +1:00</p>		
<p>Europe / Africa (Nuremberg) Authorization</p> <p>Loc. time: Mon. through Fri. 8 AM to 5 PM Phone: +49 (0) 180 5050-222 Fax: +49 (0) 180 5050-223 E-mail: adsupport@siemens.com GMT: +1:00</p>	<p>America (Johnson City) Technical Support and Authorization</p> <p>Loc. time: Mon. through Fri. 8 AM to 5 PM Phone: +1 (0) 770 740 3505 Fax: +1 (0) 779 740 3699 E-mail: isd-callcenter@sea.siemens.com GMT: -5:00</p>	<p>Asia and Australia (Peking) Technical Support and Authorization</p> <p>Loc. time: Mon. through Fri. 8.30 AM to 5.30 PM Phone: +86 10 64 75 75 75 Fax: +86 10 64 74 74 74 E-mail: adsupport.asia@siemens.com GMT: +8:00</p>
<p>Technical Support and Authorization generally speak German and English.</p>		

Service & Support on the Internet

In addition to our documentation products and services, all our knowledge is available to you on the Internet.

<http://www.siemens.com/automation/service&support>

Available over the Internet are:

- the newsletter, constantly bringing you the latest information about our products.
- the right documents for you, thanks to our Search in Service & Support.
- a forum in which users and specialists can swap experiences world-wide.
- your local point of contact for Automation & Drives in our Contacts Database
- information about local service, repairs, spare parts. Much more is available to you under "Achievements".

Contents

	Preface	
1	General Technical Specifications	
1.1	Standards and Approvals	1-2
1.2	Electromagnetic Compatibility	1-6
1.3	Shipping and Storage Conditions for Modules and Backup Batteries	1-8
1.4	Mechanical and Climatic Environmental Conditions for Operating S7-300s	1-9
1.5	Information on Insulation Tests, Protection Class and Degree of Protection	1-12
1.6	Rated Voltages of the S7-300	1-13
1.7	SIMATIC Outdoor Modules	1-14
1.8	Mechanical and Climatic Environmental Conditions for Operating SIMATIC Outdoor Modules	1-16
1.9	Use of the ET 200M / S7-300 in a Zone 2 Potentially Explosive Area	1-17
2	Power Supply Modules	
2.1	Power Supply Module PS 305; 2 A; (6ES7 305-1BA80-0AA0)	2-2
2.2	Power Supply Module PS 307; 2 A; (6ES7 307-1BA00-0AA0)	2-6
2.3	Power Supply Module PS 307; 5 A; (6ES7 307-1EAx0-0AA0)	2-10
2.4	Power Supply Module PS 307; 10 A; (6ES7 307-1KA00-0AA0)	2-15
3	Digital Modules	
3.1	Module Overview	3-4
3.2	Sequence of Steps from Choosing to Commissioning the Digital Module	3-10
3.3	Digital Module Parameter Assignment	3-11
3.4	Diagnostics of the Digital Modules	3-12
3.5	Digital Input Module SM 321; DI 32 × 24 VDC; (6ES7 321-1BLx0-0AA0)	3-13
3.6	Digital Input Module SM 321; DI 32 × 120 VAC; (6ES7 321-1EL00-0AA0)	3-16
3.7	Digital Input Module SM 321; DI 16 × 24 VDC; (6ES7 321-1BHx2-0AA0)	3-18

3.8	Digital Input Module SM 321; DI 16 × 24 VDC High Speed; (6ES7 321-1BH10-0AA0)	3-21
3.9	Digital Input Module SM 321; DI 16 × 24 VDC; with Hardware and Diagnostic interrupts; (6ES7 321-7BHx0-0AB0)	3-23
3.9.1	Assigning Parameters to the SM 321; DI 16 × 24 VDC	3-26
3.9.2	Behavior and Diagnostics of the SM 321; DI 16 × 24 VDC	3-28
3.9.3	Interrupts of the SM 321; DI 16 × 24 VDC	3-31
3.10	Digital Input Module SM 321; DI 16 × DC 24 V; Source Input; (6ES7 321-1BH50-0AA0)	3-33
3.11	Digital Input Module SM 321; DI 16 × UC 24/48 V; (6ES7 321-1CH00-0AA0)	3-35
3.12	Digital Input Module SM 321; DI 16 × 48-125 VDC; (6ES7 321-1CH80-0AA0)	3-37
3.13	Digital Input Module SM 321; DI 16 × AC 120/230 V (6ES7 321-1FH00-0AA0)	3-39
3.14	Digital Input Module SM 321; DI 8 × 120/230 VAC; (6ES7 321-1FFx1-0AA0)	3-41
3.15	Digital Input Module SM 321; DI 8 × 120/230 VAC ISOL (6ES7 321-1FF10-0AA0)	3-43
3.16	Digital Output Module SM 322; DO 32 × 24 VDC/ 0.5 A; (6ES7 322-1BL00-0AA0)	3-45
3.17	Digital Output Module SM 322; DO 32 × 120 VAC/1.0 A; (6ES7 322-1EL00-0AA0)	3-48
3.18	Digital Output Module SM 322; DO 16 × 24 VDC/ 0.5 A; (6ES7 322-1BHx1-0AA0)	3-52
3.19	Digital Output Module SM 322; DO 16 × 24 VDC/0.5 A High Speed; (6ES7 322-1BH10-0AA0)	3-55
3.20	Digital Output Module SM 322; DO 16 × 24/48 VUC; (6ES7 322-5GH00-0AB0)	3-58
3.21	Digital Output Module SM 322; DO 16 × 120/230 VAC/1 A: (6ES7 322-1FH00-0AA0)	3-64
3.22	Digital Output Module SM 322; DO 8 × 24 VDC/2 A; (6ES7 322-1BF01-0AA0)	3-67
3.23	Digital Output Module SM 322; DO 8 × 24 VDC/ 0.5 A; with Diagnostic Interrupt; (6ES7 322-8BFx0-0AB0)	3-70
3.23.1	Assigning Parameters to the SM 322; DO 8 × 24 VDC/0.5 A	3-75
3.23.2	Behavior and Diagnostics of the SM 322; DO 8 × 24 VDC/0.5 A	3-76
3.23.3	Interrupts of the SM 322; DO 8 × 24 VDC/0.5 A	3-79
3.24	Digital Output Module SM 322; DO 8 × 48-125 VDC/1.5 A; (6ES7 322-1CF80-0AA0)	3-80

3.25	Digital Output Module SM 322; DO 8 × 120/230 VAC/2 A; (6ES7 322-1FFx1-0AA0)	3-83
3.26	Digital Output Module SM 322; DO 8 × 120/230 VAC/2 A ISOL (6ES7 322-5FF00-0AB0)	3-86
3.27	Relay Output Module SM 322; DO 16 × Rel. 120/230 VAC; (6ES7 322-1HH01-0AA0)	3-92
3.28	Relay Output Module SM 322; DO 8 × Rel. 230 VAC; (6ES7 322-1HF01-0AA0)	3-95
3.29	Relay Output Module SM 322; DO 8 × Rel. 230 VAC/5A; (6ES7 322-5HF00-0AB0)	3-98
3.29.1	SM 322; DO 8 × Rel. 230 VAC/5A parameterization	3-102
3.29.2	Behavior and Diagnostics of the SM 322; DO 8 × 230 VDC/0.5 A	3-103
3.30	Relay Output Module SM 322; DO 8 × Rel. 230 VAC/5 A; (6ES7 322-1HFx0-0AA0)	3-105
3.31	Digital Input/Output Module SM 323; DI 16/DO 16 × 24 VDC/0.5 A; (6ES7 323-1BL00-0AA0)	3-110
3.32	Digital Input/Output Module SM 323; DI 8/DO 8 × 24 VDC/0.5 A; (6ES7 323-1BHx1-0AA0)	3-114
4	Analog Modules	
4.1	Module Overview	4-3
4.2	Sequence of Steps from Choosing to Commissioning the Module	4-8
4.3	Analog Value Representation	4-10
4.3.1	Analog Value Representation for Analog Input Channels	4-11
4.3.2	Analog Value Representation for Analog Output Channels	4-26
4.4	Setting the Measuring Method and Measuring Ranges of Analog Input Channels	4-31
4.5	Behavior of the Analog Modules	4-34
4.5.1	Effect of Supply Voltage and Operating Mode	4-34
4.5.2	Effect of Range of Values of the Analog Values	4-36
4.5.3	Effect of Operational Limit and Basic Error Limit	4-38
4.6	Conversion, Cycle, Setting and Response Time of Analog Modules	4-39
4.7	Analog Module Parameter Assignment	4-43
4.7.1	Parameters of the Analog Input Modules	4-44
4.7.2	Parameters of the Analog Output Modules	4-47
4.7.3	Parameters of the Analog Input/Output Modules	4-48
4.8	Connecting Sensors to Analog Inputs	4-49
4.9	Connecting Voltage Sensors	4-54
4.10	Connecting Current Sensors	4-55
4.11	Connecting Resistance Thermometers and Resistors	4-57
4.11.1	Connecting Resistance Thermometers to the SM 331; AI 8 × 13 bits	4-61

4.12	Connecting Thermocouples	4-63
4.13	Connecting Loads/Actuators to Analog Output	4-72
4.14	Connecting Loads and Actuators to Voltage Outputs	4-73
4.15	Connecting Loads and Actuators to Current Outputs	4-76
4.16	Diagnostics of the Analog Modules	4-77
4.17	Interrupts of the Analog Modules	4-81
4.18	Analog Input Module SM 331; AI 8 × 16 bits; (6ES7 331-7NF00-0AB0)	4-83
4.18.1	Commissioning the SM 331; AI 8 × 16 bits	4-87
4.18.2	Measuring Methods and Measuring Ranges of the SM 331; AI 8 × 16 bits	4-89
4.19	Analog Input Module SM 331; AI 8 × 16 bits (6ES7 331-7NF10-0AB0)	4-92
4.19.1	Commissioning the SM 331; AI 8 × 16 bits	4-96
4.19.2	8-Channel Mode	4-99
4.19.3	4 Channel-Mode	4-101
4.19.4	Measuring Methods and Measuring Ranges of the SM 331; AI 8 × 16 bits	4-102
4.20	Analog Input Module SM 331; AI 8 × 13 bits; (6ES7 331-1KF00-0AB0)	4-105
4.20.1	Parameters of the SM 331; AI 8 × 13 bits	4-109
4.20.2	Measuring Methods of the SM 331; AI 8 × 13 bits	4-110
4.21	Analog Input Module SM 331; AI 8 × 12 bits; (6ES7 331-7KF02-0AB0)	4-111
4.21.1	Commissioning the SM 331; AI 8 × 12 bits	4-115
4.21.2	Measuring Methods and Measuring Ranges of the SM 331; 8 × 12 bits	4-119
4.22	Analog Input Module SM 331; AI 8 × RTD (6ES7 331-7PF00-0AB0)	4-122
4.22.1	Commissioning the SM 331; AI 8 × RTD	4-126
4.22.2	Measuring Methods and Measuring Ranges of the SM 331; AI 8 × RTD	4-132
4.23	Analog Input Module SM 331; AI 8 × TC (6ES7 331-7PF10-0AB0)	4-135
4.23.1	Commissioning the SM 331; AI 8 × TC	4-140
4.23.2	Measuring Methods and Measuring Ranges of the SM 331; AI 8 × TC ..	4-147
4.24	Analog Input Module SM 331; AI 2 × 12 bits; (6ES7 331-7KBx2-0AB0)	4-150
4.24.1	Commissioning the SM 331; AI 2 × 12 bits	4-154
4.24.2	Measuring Methods and Measuring Ranges of the SM 331; AI 2 × 12 bits	4-157
4.25	Analog Output Module SM 332; AO 8 × 12 bits; (6ES7 332-5HF00-0AB0)	4-160
4.25.1	Commissioning the SM 332; AO 8 × 12 bits	4-163
4.25.2	Output Ranges of the Analog Output Module SM 332; AO 8 × 12 bits	4-164

4.26	Analog Output Module SM 332; AO 4 × 16 bits; (6ES7 332-7ND01-0AB0)	4-166
4.26.1	Commissioning the SM 332; AO 4 × 16 bits	4-169
4.26.2	Output Ranges of the Analog Output Module SM 332; AO 4 × 16 bits ...	4-170
4.27	Analog Output Module SM 332; AO 4 × 12 bits; (6ES7 332-5HD01-0AB0)	4-171
4.27.1	Commissioning the SM 332; AO 4 × 12 bits	4-174
4.27.2	Output Ranges of the Analog Output Module SM 332; AO 4 × 12 bits ...	4-175
4.28	Analog Input/Output Module SM 332; AO 2 × 12 bits; (6ES7 332-5HBx1-0AB0)	4-177
4.28.1	Commissioning the SM 332; AO 2 × 12 bits	4-180
4.28.2	Output Ranges of the Analog Output Module SM 332; AO 2 × 12 bits ...	4-181
4.29	Analog Input/Output Module SM 334; AI 4/AO 2 × 8/8 bits; (6ES7 334-0CE01-0AA0)	4-183
4.29.1	Commissioning the SM 334; AI 4/AO 2 × 8/8 bits	4-187
4.29.2	Measuring/Output Method and Measuring/Output Range of the SM 334; AI 4/AO 2 × 8/8 bits	4-188
4.30	Analog Input/Output Module SM 334; AI 4/AO 2 × 12 bits; (6ES7 334-0KE00-0AB0)	4-189
4.30.1	Commissioning the SM 334; AI 4/AO 2 × 12 bits	4-193
4.30.2	Measuring/Output Method and Measuring/Output Range of the SM 334; AI 4/AO 2 × 12 bits	4-193
5	Other Signal Modules	
5.1	Module Overview	5-2
5.2	Simulator Module SM 374; IN/OUT 16; (6ES7 374-2XH01-0AA0)	5-3
5.3	Dummy Module DM 370; (6ES7 370-0AA01-0AA0)	5-5
5.4	Position Detection Module SM 338; POS-INPUT; (6ES7 338-4BC01-0AB0)	5-8
5.4.1	Isochrone Mode	5-9
5.4.2	Terminal connection diagram and block diagram	5-10
5.4.3	Functions of the SM 338; POS-INPUT	5-11
5.4.4	Encoder Value Detection	5-11
5.4.5	Gray / Binary Converter	5-12
5.4.6	Transmitted Encoder Value and Normalizing	5-12
5.4.7	Enable FREEZE function	5-13
5.4.8	Assigning Parameters to the SM 338; POS-INPUT	5-14
5.4.9	Addressing SM 338; POS-INPUT	5-16
5.4.10	Diagnostics of the SM 338; POS-INPUT	5-18
5.4.11	Interrupts of the SM 338; POS-INPUT	5-21
5.4.12	Technical specifications of the SM 338; POS-INPUT	5-22

6	Interface Modules	
6.1	Module Overview	6-2
6.2	Interface Module IM 360; (6ES7 360-3AA01-0AA0)	6-3
6.3	Interface Module IM 361; (6ES7 361 3CA01-0AA0)	6-5
6.4	Interface Module IM 365; (6ES7 365-0BA01-0AA0)	6-7
7	RS 485 Repeater	
7.1	Application and Characteristics; (6ES7 972-0AA01-0XA0)	7-2
7.2	Appearance of the RS 485 Repeater; (6ES7 972-0AA01-0XA0)	7-3
7.3	RS 485 Repeater in Ungrounded and Grounded Operation	7-4
7.4	Technical Specifications	7-7
8	SIMATIC TOP connect and SIMATIC TOP connect TPA	
8.1	Module Overview	8-2
8.2	Wiring Components	8-4
8.2.1	Cut the Connecting Cable to Length and Terminate	8-4
8.2.2	Wiring the Front Connector Module	8-6
8.2.3	Connecting the Connecting Cable to the Terminal Block	8-10
8.2.4	Wiring Actuators/Sensors to the Terminal Block	8-10
8.3	Wiring SIMATIC TOP connect with Digital Modules	8-12
8.3.1	SIMATIC TOP connect Components and Selection Aid	8-12
8.3.2	Wiring the Module with Terminal Block for One-Conductor Connection ..	8-14
8.3.3	Wiring the Module with Terminal Block for Three-Conductor Connection	8-16
8.3.4	Wiring the Module with Terminal Block for 2A Modules	8-18
8.4	Wiring SIMATIC TOP connect TPA with Analog Modules	8-20
8.4.1	SIMATIC TOP connect TPA Components and Selection Aid	8-20
8.4.2	SIMATIC TOP connect TPA Terminal Assignment and Terminal Allocation	8-21
8.4.3	Connecting the Signal-Line Shield	8-23
8.4.4	Connection Example	8-24

A	Parameter Sets for Signal Modules	
A.1	How to Assign the Parameters for Signal Modules in the User Program .	A-1
A.2	Parameters of the Digital Input Modules	A-3
A.3	Parameters of the Digital Output Modules	A-5
A.4	Parameters of the Analog Input Modules	A-7
A.5	Parameters of the SM 331; AI 8 × RTD	A-11
A.6	Parameters der SM 331; AI 8 × TC	A-19
A.7	Parameters of the SM 331; AI 8 × 13 bits	A-27
A.8	Parameters of the SM 331; AI 8 × 16 bits	A-29
A.9	Parameters of the Analog Output Modules	A-35
A.10	Parameters of the SM 332; AO 8 × 12 bits	A-38
A.11	Parameters of the Analog Input/Output Modules	A-40
B	Diagnostics Data of Signal Modules	
B.1	Evaluating Diagnostic Data of the Signal Modules in the User Program .	B-1
B.2	Structure and Content of Diagnostic Data Bytes 0 to 7	B-2
B.3	Channel-Specific Diagnostic Data from Byte 8	B-5
B.4	Diagnostic Data of the SM 338; POS-INPUT	B-7
C	Dimension Drawings	
C.1	Dimension Drawings of the Rails	C-2
C.2	Dimension Drawings of the Power Supply Modules	C-9
C.3	Dimension Drawings of the Interface Modules	C-14
C.4	Dimension Drawings of the Signal Modules	C-17
C.5	Dimension Drawings for Accessories	C-18
D	Spare Parts and Accessories for S7-300 Modules	
E	Guidelines for Handling Electrostatic Sensitive Devices (ESD)	
E.1	What is ESD?	E-2
E.2	Electrostatic Charging of Persons	E-3
E.3	General Protective Measures Against Electrostatic Discharge Damage .	E-4
F	List of Abbreviations	
	Glossary	
	Index	

Figures

2-1	Wiring Schematic of the PS 305 Power Supply Module (2 A)	2-3
2-2	Basic Circuit Diagram of the PS 305 Power Supply Module (2 A)	2-5
2-3	Wiring Schematic of the PS 307 Power Supply Module (2 A)	2-7
2-4	Basic Circuit Diagram of the PS 307 Power Supply Module (2 A)	2-7
2-5	Wiring Schematic of the PS 307 Power Supply Module (5 A)	2-11
2-6	Basic Circuit Diagram of the PS 307 Power Supply Module (5 A)	2-12
2-7	Wiring Schematic of the PS 307 Power Supply Module (10 A)	2-15
2-8	Basic Circuit Diagram of the PS 307 Power Supply Module (10 A)	2-16
3-1	Module View and Block Diagram of the Digital Input Module SM 321; DI 32 × 24 VDC	3-14
3-2	Terminal assignment of the SM 321; DI 32 × 24 VDC	3-14
3-3	Module View and Block Diagram of Digital Input Module SM 321; DI 32 × 120 VAC	3-16
3-4	Module View and Block Diagram of Digital Input Module SM 321; DI 16 × 24VDC	3-19
3-5	Module View and Block Diagram of the SM 321; DI 16 × 24 VDC High Speed	3-21
3-6	Module View and Block Diagram of the SM 321; DI 16 × 24 VDC (6ES7 321-7BHx0-0AB0)	3-24
3-7	Terminal Assignment for the Redundant Supply of Encoders of the SM 321; DI 16 × 24 VDC (6ES7 321-7BHx0-0AB0)	3-24
3-8	Module View and Block Diagram of Digital Input Module SM 321; DI 16 × 24 VDC (Source Input)	3-33
3-9	Module View and Block Diagram of Digital Input Module SM 321; DI 16 × 24/48VUC	3-35
3-10	Module View and Block Diagram of SM 321; DI 16 × 48-125 VDC	3-37
3-11	Module View and Block Diagram of the SM 321; DI 16 × 120/230 VAC ..	3-39
3-12	Module View and Block Diagram of the SM 321; DI 8 × 120/230 VAC ...	3-41
3-13	Module View and Block Diagram of the SM 321; DI 8 × 120/230 VAC ISOL	3-43
3-14	Module View and Block Diagram of Digital Output Module SM 322; DO 32 × 24 VDC/0.5 A	3-46
3-15	Terminal Assignment of the SM 322; DO 32 × 24 VDC	3-46
3-16	Module View and Block Diagram of the SM 322; DO 32 × 120 VAC/1.0 A	3-49
3-17	Terminal Assignment of the SM 322; DO 32 × 120 VAC/1.0 A	3-50
3-18	Module View and Block Diagram of the SM 322; DO 16 × 24 VDC/0.5 A	3-53
3-19	Module View and Block Diagram of the SM 322; DO 16 × 24 VDC/0.5 A High Speed	3-56
3-20	Module View and Block Diagram of SM 322; DO 16 × 24/48 VUC	3-59
3-21	Module View and Block Diagram of the SM 322; DO 16 × 120/230 VAC/1 A	3-65
3-22	Module View and Block Diagram of Digital Output Module SM 322; DO 8 × 24 VDC/2 A	3-68
3-23	Module View of the SM 322; DO 8 × 24 V DC/0.5 A	3-71
3-24	Block Diagram of the SM 322; DO 8 × DC 24 V/0.5 A	3-72
3-25	Module View and Block Diagram of the SM 322; DO 8 × 48-125 VDC/1.5 A	3-81
3-26	Module View and Block Diagram of the SM 322; DO 8 × 120/230 VAC/2 A	3-84
3-27	Module View and Block Diagram of the SM 322; DO 8 × 120/230 VAC/2 A ISOL	3-87

3-28	Module View and Block Diagram of SM 322; DO 16 × Rel. 120/230 VAC	3-93
3-29	Module View and Block Diagram of the SM 322; DO 8 × Rel. 230 VAC . .	3-96
3-30	Module View and Block Diagram of the SM 322; DO 8 × Rel. 230 VAC/5A	3-99
3-31	Special Characteristic for Operation with a Safe Electrical Extra-Low Voltage	3-100
3-32	Module View and Block Diagram of the SM 322; DO 8 × Rel. 230 VAC/5 A	3-106
3-33	Special Characteristic for Operation with a Safe Electrical Extra-Low Voltage	3-107
3-34	Module View and Block Diagram of the SM 323; DI 16/DO 16 × 24 VDC/0.5 A	3-111
3-35	Terminal Assignment of the SM 323; DI 16/DO 16 × 24 VDC/0.5 A	3-112
3-36	Module View and Block Diagram of Digital Input/Output Module SM 323; DI 8/DO 8 × 24 VDC/0.5 A	3-115
4-1	Easing Measuring Range Modules from the Analog Input Module	4-32
4-2	Inserting Measuring Range Modules into the Analog Input Module	4-33
4-3	Example of the Relative Error of an Analog Output Module	4-38
4-4	Scan Time of an Analog Input or Output Module	4-39
4-5	Example of the Influence of Smoothing on the Step Response	4-41
4-6	Settling and Response times of the Analog Output Channels	4-42
4-7	Connecting Isolated Sensors to an Isolated AI	4-51
4-8	Connecting Isolated Sensors to a Non-Isolated AI	4-51
4-9	Connecting Non-Isolated Sensors to an Isolated AI	4-52
4-10	Connecting non-isolated sensors to a non-isolated AI	4-53
4-11	Connecting Voltage Sensors to an Isolated AI	4-54
4-12	Connecting Two-Wire Transmitters to an Isolated AI	4-56
4-13	Connecting Two-Wire Transmitters Supplied from L+ to an Isolated AI	4-56
4-14	Connecting Four-Wire Transmitters to an Isolated AI	4-57
4-15	Four-conductor connection of resistance thermometers to an isolated AI	4-58
4-16	Three-Conductor Connection of Resistance Thermometers to an Isolated AI	4-59
4-17	Two-Conductor Connection of Resistance Thermometers to an Isolated AI	4-59
4-18	Three-Conductor Connection of Resistance Thermometers to the SM 331; AI 8 × RTD	4-60
4-19	Two-Conductor Connection of Resistance Thermometers to the SM 331; AI 8 × 13 bits	4-61
4-20	Three-Conductor Connection of Resistance Thermometers to the SM 331; AI 8 × 13 bits	4-61
4-21	Four-Conductor Connection of Resistance Thermometers to the SM 331; AI 8 × 13 bits	4-62
4-22	Design of Thermocouples	4-63
4-23	Connection of Thermocouples with Internal Compensation to an Isolated AI	4-66
4-24	Connection of Thermocouples with Compensation Box to an Isolated AI	4-67
4-25	Connection of Thermocouples with Comparison Point (Order No. M72166-xxx00) to an Isolated AI	4-69
4-26	Connecting Thermocouples via a Reference Junction to the SM 331; AI 8 × TC	4-70

4-27	Connecting Thermocouples with External Compensation via Resistance Thermometers to the SM 331; AI 8×TC	4-71
4-28	Connecting Loads to a Voltage Output of an Isolated AO over a Four-Conductor Connection	4-74
4-29	Connecting Loads to a Voltage Output of a Non-Isolated AO over a Two-Conductor Connection	4-75
4-30	Connecting Loads to a Current Output of an Isolated AO	4-76
4-31	Connecting Loads to a Current Output of a Non-Isolated AO	4-77
4-32	Start Information of OB 40: Which Event Has Triggered the Hardware Interrupt at the Limit Value	4-82
4-33	Module View and Block Diagram of the Analog Input Module SM 331; AI 8×16 bits	4-84
4-34	Module View and Block Diagram of the SM 331; AI 8×16 bits	4-93
4-35	8-Channel Mode Cycle	4-99
4-36	4-Channel Mode Cycle	4-101
4-37	Module View and Block Diagram of the Analog Input Module SM 331; AI 8×13 bits	4-106
4-38	Module View and Block Diagram of the Analog Input Module SM 331; AI 8×12 bits	4-112
4-39	Module View and Block Diagram of the SM 331; AI 8×RTD	4-123
4-40	Hardware Filter 8 Channels Scan Time	4-129
4-41	Software Filter 8 Channels Scan Time	4-130
4-42	Hardware Filter 4 Channels Scan Time	4-131
4-43	Module View and Block Diagram of the SM 331; AI 8×TC	4-136
4-44	Hardware Filter 8 Channels Scan Time	4-143
4-45	Software Filter 8 Channels Scan Time	4-144
4-46	Hardware Filter 4 Channels Scan Time	4-145
4-47	Module View and Block Diagram of the Analog Input Module SM 331; AI 2×12 bits	4-151
4-48	Module View and Block Diagram of the Analog Output Module SM 332; AO 8×12 bits	4-161
4-49	Module View and Block Diagram of the SM 332; AO 4×16 bits	4-167
4-50	Module View and Block Diagram of the Analog Output Module SM 332; AO 4×12 bits	4-172
4-51	Module View and Block Diagram of the Analog Output Module SM 332; AO 2×12 bits	4-178
4-52	Module View and Block Diagram of the Analog Input/Output Module SM 334; AI 4/AO 2×8/8 bits	4-184
4-53	Module View and Block Diagram of the SM 334; AI 4/AO 2×12 bits	4-190
5-1	Module View of Simulator Module SM 374; IN/OUT 16	5-4
5-2	Module View of Dummy Module DM 370	5-6
5-3	Module View and Block Diagram of the SM 338; POS-INPUT	5-10
6-1	Front View of the Interface Module IM 360	6-4
6-2	Front View of the Interface Module IM 361	6-6
6-3	Front View of the Interface Module IM 365	6-8
7-1	RC Network with 10 MΩ for Configuration with Ungrounded Reference Potential	7-5
7-2	Isolation between the Bus Segments	7-6
7-3	Block Diagram of the RS 485 Repeater	7-8
8-1	SIMATIC TOP connect on a S7-300	8-2
8-2	Threading the Round-Sheath Ribbon Cable into the Connector	8-5
8-3	Inserting the Connecting Cable into the Front Connector Module	8-8

8-4	Front connector module for 32-channel digital modules	8-9
8-5	Insert the Connecting Cable into the Terminal Block	8-10
8-6	Spring-Loaded Terminal Block	8-11
8-7	Principle of Spring-Loaded Connections	8-11
8-8	Wiring a Digital Module with Terminal Block for a One-Conductor Connection	8-15
8-9	Wiring a Digital Module with Terminal Block for a Three-Conductor Connection	8-17
8-10	Wiring with Terminal Block for 2A Module	8-19
8-11	Terminal Assignment of Analog Module to SIMATIC TOP connect TPA .	8-22
8-12	SIMATIC TOP connect TPA Terminal Block with Shielding Plate	8-23
8-13	Example of Connecting SIMATIC TOP connect TPA to SM 321; AI 8 × 12 bits	8-24
A-1	Data Record 1 for Parameters of the Digital Input Modules	A-4
A-2	Data Record 1 for Parameters of the Digital Output Modules	A-6
A-3	Data Record 1 for Parameters of the Analog Input Modules	A-8
A-4	Data Record 1 of the Parameters for SM 331; AI 8 × RTD	A-12
A-5	Data Record 128 of the Parameters for SM 331; AI 8 × RTD	A-13
A-6	Data Record 128 of the SM 331; AI 8 × RTD (Continued)	A-14
A-7	Data Record 128 of the SM 331; AI 8 × RTD (Continued)	A-15
A-8	Data Record 1 of the Parameters for SM 331; AI 8 × TC	A-20
A-9	Data Record 128 of the SM 331; AI 8 × TC	A-21
A-10	Data Record 128 of the SM 331; AI 8 × TC (Continued)	A-22
A-11	Data Record 128 of the SM 331; AI 8 × TC (Continued)	A-23
A-12	Data Record 1 for Parameters of the Analog Input Modules	A-27
A-13	Data Record 1 of the Parameters for SM 331; AI 8 × 16 bits	A-30
A-14	Data record 128 for parameters of the SM 331; AI 8 × 16 bits	A-31
A-15	Data record 128 for SM 331; AI 8 × 16 bits (continued)	A-32
A-16	Data record 128 for parameters of the SM 331; AI 8 × 16 bits (continued)	A-33
A-17	Data Record 1 for Parameters of the Analog Output Modules	A-36
A-18	Data Record 1 for Parameters of the Analog Output Modules	A-39
A-19	Data Record 1 for Parameters of the Analog Input/Output Modules	A-41
B-1	Bytes 0 and 1 of the Diagnostic Data	B-2
B-2	Bytes 2 and 3 of the Diagnostics Data	B-3
B-3	Bytes 4 to 7 of the Diagnostics Data	B-4
B-4	Diagnostic Byte for a Digital Input Channel of the SM 321; DI 16 × 24 VDC	B-5
B-5	Diagnostic Byte for a Digital Output Channel of the SM 322; DO 8 × 24 VDC/0.5 A	B-5
B-6	Diagnostic Byte for an Analog Input Channel of a SM 331 with Diagnostics Capability	B-6
B-7	Diagnostic Byte for an Analog Output Channel of a SM 332 with Diagnostics Capability	B-6
B-8	Bytes 0 and 1 of the Diagnostic Data for the SM 338; POS-INPUT	B-7
B-9	Bytes 2 and 7 of the Diagnostic Data for the SM 338; POS-INPUT	B-8
B-10	Diagnostic Byte for a Channel of the SM 338; POS-INPUT	B-8

C-1	Dimension Drawing of the 483 mm Standard Rail	C-2
C-2	Dimension Drawing of the 530 mm Standard Rail	C-3
C-3	Dimension Drawing of the 830 mm Standard Rail	C-3
C-4	Dimension Drawing of the 2000 mm Standard Rail	C-4
C-5	Dimension Drawing of the Rail with 160 mm Standard Width	C-4
C-6	Dimension Drawing of the Rail with 482.6 mm Standard Width	C-5
C-7	Dimension Drawing of the Rail with 530 mm Standard Width	C-5
C-8	Dimension Drawing of the Rail with 830 mm Standard Width	C-6
C-9	Dimension Drawing of the 2000 mm Rail	C-6
C-10	Complete Dimension Drawing of a Rail for "Insert and Remove" Function with Active Bus Module, S7-300 Module and Explosion-proof Partition	C-7
C-11	Dimension Drawing of the Active Bus Modules	C-8
C-12	Power Supply Module PS 307; 2 A	C-9
C-13	Power Supply Module PS 307; 5 A	C-10
C-14	Power Supply Module PS 307; 10 A	C-11
C-15	Dimension Drawing of the Power Supply Module PS 307; 5 A with CPUs 313/314/315/315-2 DP. Front View	C-12
C-16	Dimension Drawing of the Power Supply Module PS 307; 5 A with CPUs 313/314/315/315-2 DP. Side View	C-13
C-17	Interface Module IM 360	C-14
C-18	Interface Module IM 361	C-15
C-19	Interface Module IM 365	C-16
C-20	Signal Module	C-17
C-21	2 Signal Modules with Shield Connecting Element	C-18
C-22	SIMATIC TOP connect, 3-tier	C-19
C-23	SIMATIC TOP connect, 2-tier	C-19
C-24	SIMATIC TOP connect, 1-tier	C-20
C-25	RS 485 Repeater on Standard Rail	C-20
C-26	RS 485 repeater on S7-300 rail	C-21
E-1	Electrostatic Voltages which Can Build up on a Person	E-3

Tables

1-1	Use in an Industrial Environment	1-5
1-2	Pulse-Shaped Interference	1-6
1-3	Sinusoidal Interference	1-7
1-4	Shipping and Storage Conditions for Modules	1-8
1-5	Mechanical Conditions	1-10
1-6	Ambient Mechanical Conditions Test	1-10
1-7	Climatic Conditions	1-11
1-8	Test Voltages	1-12
1-9	Rated Voltages	1-13
1-10	"SIMATIC Outdoor Modules"	1-15
1-11	Outdoor Modules Ambient Mechanical Conditions Test	1-16
1-12	Outdoor Modules Climatic Conditions	1-17
2-1	Reaction of the PS 305 Power Supply Module (2 A) to Atypical Operating Conditions	2-5
2-2	Reaction of the PS 307 Power Supply Module (2 A) to Atypical Operating Conditions	2-8
2-3	Reaction of the PS 307 Power Supply Module (5 A) to Atypical Operating Conditions	2-12
2-4	Reaction of the PS 307 Power Supply Module (10 A) to Atypical Operating Conditions	2-16
3-1	Digital Input Modules: Characteristics at a Glance	3-4
3-2	Digital Input Modules: Characteristics at a Glance (continued)	3-5
3-3	Digital Output Modules: Characteristics at a Glance	3-6
3-4	Digital Output Modules: Characteristics at a Glance (continued)	3-7
3-5	Relay Output Modules: Characteristics at a Glance	3-8
3-6	Digital Input/Output Modules: Characteristics at a Glance	3-9
3-7	Sequence of Steps from Choosing to Commissioning the Digital Module	3-10
3-8	Parameters of the SM 321; DI 16 × 24 VDC (6ES7 321-7BHx0-0AB0) ..	3-26
3-9	Assigning the Interrupt Parameters to the Inputs of the SM 321; DI 16 × 24 VDC (6ES7 321-7BHx0-0AB0)	3-27
3-10	Tolerances of the Input Delays of SM 321; DI 16 × 24 VDC (6ES7 321-7BHx0-0AB0)	3-27
3-11	Dependencies of Input Values on the Operating Mode of the CPU and Supply Voltage L+ of the SM 321; DI 16 × 24 VDC (6ES7 321-7BHx0-0AB0) ...	3-28
3-12	Diagnostic Messages of the SM 321; DI 16 × 24 VDC (6ES7 321-7BHx0-0AB0)	3-28
3-13	Diagnostic Messages of the SM 321; DI 16 × 24 VDC (6ES7 321-7BHx0-0AB0), Causes of Error and Remedial Measures ...	3-30
3-14	Data record no. 0 (static parameters):	3-61
3-15	Data record no. 1 (dynamic parameters):	3-61
3-16	Structure of the Data Record for SM 322 DO 16 × UC 24/48 V	3-62
3-17	System Diagnostics for SM 322 DO 16 × UC 24/48 V	3-62
3-18	Parameters of the SM 322; DO 8 × 24 VDC/0.5 A	3-75
3-19	Dependence of the Output Values on the Operating Mode of the CPU and on the Supply Voltage L+ of the SM 322; DO 8 × 24 VDC/0.5 A.	3-76
3-20	Diagnostic Messages of the SM 322; DO 8 × 24 VDC/0.5 A	3-77
3-21	Diagnostic Messages of the SM 322; DO 8 × 24 VDC/0.5 A, Causes of Error and Remedial Action	3-78

3-22	Parameters of the SM 322; DO 8 × 120/230 VAC/2 A ISOL	3-89
3-23	Diagnostic Messages of the SM 322; DO 8 × 120/230 VAC/2 A ISOL ..	3-90
3-24	Diagnostic Messages of the SM 322; DO 8 × 120/230 VAC/2 A ISOL, Error Causes and Remedies	3-90
3-25	Parameters of the SM 322; DO 8 × Rel. 230 VAC/5A	3-102
3-26	Diagnostic Messages of the SM 322; DO 8 × Rel. AC 230 VDC/0.5 A ...	3-103
3-27	Diagnostic Messages of the SM 322; DO 8 × Rel. 230 VAC/5A, Error Causes and Remedies	3-104
4-1	Analog Input Modules: Characteristics at a Glance	4-4
4-2	Analog input modules: Characteristics at a glance (continued)	4-5
4-3	Analog Output Modules: Characteristics at a Glance	4-6
4-4	Analog Input/Output Modules: Characteristics at a Glance	4-7
4-5	Sequence of Steps from Choosing to Commissioning the Analog Module	4-8
4-6	Example: Bit Pattern of a 16-Bit and a 13-Bit Analog Value	4-11
4-7	Possible Analog Value Resolutions	4-12
4-8	Bipolar Input Ranges	4-13
4-9	Unipolar Input Ranges	4-13
4-10	Analog Value Representation in Voltage Measuring Ranges ± 10 V to ± 1 V	4-14
4-11	Analog Value Representation in Voltage Measuring Ranges ± 500 mV to ± 80 mV	4-15
4-12	Analog Value Representation in Voltage Measuring Ranges 1 to 5 V and 0 to 10V	4-15
4-13	Analog Value Representation in Current Measuring Ranges ± 20 mA to ± 3.2 mA	4-16
4-14	Analog Value Representation in Current Measuring Ranges 0 to 20 mA and 4 to 20 mA	4-16
4-15	Analog Value Representation for Resistance Type Transmitters from 10 kΩ and from 150 Ω to 600 Ω	4-17
4-16	Analog Value Representation for RTD Resistance Temperature Detectors Pt 100, 200, 500, 1000	4-17
4-17	Analog Value Representation for RTD Resistance Temperature Detectors Pt 100, 200, 500, 1000	4-18
4-18	Analog Value Representation for RTD Resistance Temperature Detectors Ni100, 120, 200, 500, 1000	4-18
4-19	Analog Value Representation for RTD Resistance Temperature Detectors Ni 100, 120, 200, 500, 1000	4-19
4-20	Analog Value Representation for RTD Resistance Temperature Detectors Cu 10	4-19
4-21	Analog Value Representation for RTD Resistance Temperature Detectors Cu 10	4-20
4-22	Analog Value Representation for Thermocouples Type B	4-20
4-23	Analog Value Representation for Thermocouples Type C	4-21
4-24	Analog Value Representation for Thermocouples Type E	4-21
4-25	Analog Value Representation for Thermocouples Type J	4-22
4-26	Analog Value Representation for Thermocouples Type K	4-22
4-27	Analog Value Representation for Thermocouples Type L	4-23
4-28	Analog Value Representation for Thermocouples Type N	4-23
4-29	Analog Value Representation for Thermocouples Type R, S	4-24
4-30	Analog Value Representation for Thermocouples Type T	4-24
4-31	Analog Value Representation for Thermocouples Type U	4-25

4-32	Bipolar Output Ranges	4-27
4-33	Unipolar Output Ranges	4-27
4-34	Analog Value Representation in Output Range ± 10 V	4-28
4-35	Analog Value Representation in Output Ranges 0 to 10 V and 1 to 5 V ..	4-29
4-36	Analog Value Representation in Output Range ± 20 mA	4-30
4-37	Analog Value Representation in Output Ranges 0 and 20 mA and 4 to 20 mA	4-30
4-38	Dependencies of the Analog Input/Output Values on the Operating State of the CPU and the Supply Voltage L+	4-35
4-39	Behavior of the Analog Input Modules as a Function of the Position of the Analog Value within the Range of Values	4-36
4-40	Behavior of the Analog Output Modules as a Function of the Position of the Analog Value within the Range of Values	4-37
4-41	Parameters of the Analog Input Modules	4-44
4-42	Parameters of the Analog Output Modules	4-47
4-43	Parameters of the Analog Input/Output Modules	4-48
4-44	Options for Compensation of the Reference Junction Temperature	4-64
4-45	Ordering Data of the Comparison Point	4-68
4-46	Diagnostic Messages of the Analog Input Modules	4-78
4-47	Diagnostics Messages of the Analog Output Modules	4-79
4-48	Diagnostics Messages of the Analog Input Modules, Causes of Errors and Remedial Measures	4-79
4-49	Diagnostics Messages of the Analog Output Modules, Causes of Errors and Remedial Measures	4-80
4-50	Parameters of the SM 331; AI 8×16 bits	4-87
4-51	Assignment of Channels of the SM 331; AI 8×16 bits to Channel Groups	4-88
4-52	Measuring Ranges of the SM 331; AI 8×16 bits	4-89
4-53	Minimum Possible Upper and Lower Limit Values of SM 331; AI 8×16 bits	4-91
4-54	Parameters of the SM 331; AI 8×16 bits	4-97
4-55	Assignment of the Channels of the Isolated Analog Input Module SM 331; AI 8×16 bits to Channel Groups	4-98
4-56	Scan Times in 8-Channel Mode	4-100
4-57	Measuring Ranges of the SM 331; AI 8×16 bits	4-103
4-58	Content of the 4 Bytes with Additional Information from OB40 during a Hardware Interrupt or an End-of-Scan-Cycle Interrupt	4-104
4-59	Parameters of the SM 331; AI 8×13 bits	4-109
4-60	Default Settings of the SM 331; AI 8×12 bits Using Measuring Range Modules	4-116
4-61	Parameters of the SM 331; AI 8×12 bits	4-117
4-62	Assignment of Channels of the SM 331; AI 8×12 bits to Channel Groups	4-118
4-63	Measuring Ranges of the SM 331; AI 8×12 bits	4-120
4-64	Parameters of the SM 331; AI $8 \times$ RTD	4-126
4-65	Assignment of Channels of the SM 331; AI $8 \times$ RTD to Channel Groups	4-128
4-66	Scan Times in "Software Filter, 8 Channels" Mode	4-131
4-67	Measuring Ranges of the SM 331; AI $8 \times$ RTD	4-133
4-68	Content of the 4 Bytes with Additional Information from OB40 during a Hardware Interrupt or an End-of-Scan-Cycle Interrupt	4-134
4-69	Parameters of the SM 331; AI $8 \times$ TC	4-140

4-70	Assignment of Channels of the SM 331; AI 8×TC to Channel Groups . .	4-142
4-71	Scan Times in "Software Filter, 8 Channels" Mode	4-145
4-72	Measuring Ranges of the SM 331;AI 8×TC	4-147
4-73	Minimum Possible Upper and Lower Limit Values of SM 331; AI 8×TC in °C	4-148
4-74	Minimum Possible Upper and Lower Limit Values of SM 331; AI 8×TC in °C	4-149
4-75	Content of the 4 Bytes with Additional Information from OB40 during a Hardware Interrupt or an End-of-Scan-Cycle Interrupt	4-149
4-76	Default Settings of the SM 331; AI 2×12 bits Using Measuring Range Module	4-155
4-77	Parameters of the SM 331; AI 2×12 bits	4-155
4-78	Measuring Ranges of the SM 331; AI 2 x 12 bits	4-158
4-79	Output Ranges of the Analog Output Module der SM 332; AO 8×12 bits	4-165
4-80	Output Ranges of the Analog Output Module SM 332; AO 4×16 bits . . .	4-170
4-81	Output Ranges of the Analog Output Module SM 332; AO 4×12 bits . . .	4-176
4-82	Output Ranges of the Analog Output Module SM 332; AO 2×12 bits . . .	4-182
4-83	Measuring ranges of the SM 334; AI 4/AO 2×12 bits	4-194
4-84	Output Ranges of the SM 334;AI 4/AO 2×12 bits	4-195
5-1	Other Signal Modules Characteristics at a Glance	5-2
5-2	Meaning of the Switch Positions of the Dummy Module DM 370	5-6
5-3	Parameters of the SM 338; POS-INPUT	5-14
5-4	SM 338; POS-INPUT: Input Addresses	5-16
5-5	Diagnostic Messages of the SM 338; POS-INPUT	5-19
5-6	Diagnostic Messages of the SM 338, Causes of Errors and Troubleshooting	5-20
6-1	Interface Modules: Characteristics at a Glance	6-2
7-1	Maximum Cable Length of a Segment	7-2
7-2	Maximum Cable Length between Two RS 485 Repeaters	7-2
7-3	Description and Functions of the RS 485 Repeater	7-3
8-1	SIMATIC TOP connect/... TPA: ConnecModules	8-3
8-2	Sequence of Steps for Wiring SIMATIC TOP connect/... TPA	8-4
8-3	Wiring Rules for Connecting the Supply Voltage	8-7
8-4	Assignment of Connecting Cable Terminals to Address Bytes of 32-Channel Digital Modules	8-9
8-5	Components of SIMATIC TOP connect	8-12
8-6	Selection for SIMATIC TOP connect Components	8-13
8-7	Connection Notes for SIMATIC TOP connect with One-Conductor Connection	8-14
8-8	Terminal Assignments of the Terminal Block for One-Conductor Connection	8-15
8-9	Connection Notes for SIMATIC TOP connect with Three-Conductor Connection	8-16
8-10	Terminal Assignments of the Terminal Block for Three-Conductor Connection	8-16
8-11	Connection Notes for SIMATIC TOP connect with 2A Module Connection	8-18
8-12	Terminal Assignments of the Terminal Block for 2A Modules	8-18
8-13	Components for SIMATIC TOP connect TPA	8-20
8-14	Terminal Assignment of the Terminal Block of SIMATIC TOP connect TPA	8-21

A-1	SFCs for Assigning Parameters to Signal Modules	A-2
A-2	Parameters of the Digital Input Modules	A-3
A-3	Parameters of the Digital Output Modules	A-5
A-4	Parameters of the Analog Input Modules	A-7
A-5	Codes for Interference Suppression of the Analog Input Modules	A-9
A-6	Codes for the Measuring Ranges of the Analog Input Modules	A-9
A-7	Parameters of the SM 331; AI 8 × RTD	A-11
A-8	Codes of Operating Modes of the SM 331; AI 8 × RTD	A-16
A-9	Interference Frequency Suppression Codes for SM 331; AI 8 × RTD	A-16
A-10	Codes for the Measuring Ranges of the SM 331; AI 8 × RTD	A-16
A-11	Codes of Temperature Coefficients of the SM 331; AI 8 × RTD	A-18
A-12	Codes Smoothing of the SM 331; AI 8 × RTD	A-18
A-13	Parameters of the SM 331; AI 8 × TC	A-19
A-14	Codes of Operating Modes of the SM 331; AI 8 × TC	A-24
A-15	Interference Frequency Suppression Codes for SM 331; AI 8 × TC	A-24
A-16	Codes for the Measuring Ranges of the SM 331; AI 8 × TC	A-25
A-17	Codes of Reaction to Open Thermocouple of the SM 331; AI 8 × TC ...	A-26
A-18	Codes Smoothing of the SM 331; AI 8 × TC	A-26
A-19	Codes for Temperature Measurement of the Analog Input Module	A-27
A-20	Codes for Interference Suppression of the Analog Input Module	A-28
A-21	Codes for the Measuring Ranges of the Analog Input Module	A-28
A-22	Parameters for the isolated analog input module SM 331; AI 8 × 16 bits .	A-29
A-23	Codes for the Modes of SM 331; AI 8 × 16 bits	A-34
A-24	Codes for Interference Frequency Suppression of the SM 331; AI 8 × 16 bits	A-34
A-25	Codes for the Measuring Ranges of the SM 331; AI 8 × 16 bits	A-34
A-26	Codes for the Smoothing Mode Settings of the SM 331; AI 8 × 16 bits ..	A-35
A-27	Parameters of the Analog Output Modules	A-35
A-28	Codes for the Output Ranges of the Analog Output Modules	A-37
A-29	Parameters of the SM 332; AO 8 × 12 bits.	A-38
A-30	Codes for the Output Ranges of the Analog Output Module SM332; AO 8 × 12 bits	A-40
A-31	Parameters of the Analog Input/Output Modules	A-40
A-32	Codes for the Measuring Ranges of the Analog Input/Output Modules ..	A-42
A-33	Codes for the Output Ranges of the Analog Input/Output Modules	A-42
B-1	Codes of the Module Types	B-2
D-1	Accessories and Spare Parts	D-1

General Technical Specifications

What are general technical specifications?

General technical specifications include the following:

- the standards and test values which the modules of the S7-300 programmable logic controller maintain and satisfy
- the test criteria to which the S7-300 modules were tested.

In this chapter

Section	Contents	Page
1.1	Standards and Approvals	1-2
1.2	Electromagnetic Compatibility	1-6
1.3	Shipping and Storage Conditions for Modules and Backup Batteries	1-8
1.4	Mechanical and Climatic Environmental Conditions for Operating S7-300s	1-9
1.5	Information on Insulation Tests, Protection Class and Degree of Protection	1-12
1.6	Rated Voltages of the S7-300	1-13
1.7	SIMATIC Outdoor Modules	1-14
1.8	Mechanical and Climatic Environmental Conditions for Operating SIMATIC Outdoor Modules	1-16
1.9	Using the ET 200M / S7-300 in a Zone 2 Potentially Explosive Area	1-17

1.1 Standards and Approvals

CE approval



The S7-300 programmable logic controller meets the requirements and safety-related requirements of the following EU directives and conforms with the harmonized European standards (EN) for programmable controllers announced in the Official Journals of the European Community:

- 73/23/EEC "Electrical Equipment Designed for Use between Certain Voltage Limits" (Low-Voltage Directive)
- 89/336/EEC "Electromagnetic Compatibility" (EMC Directive)
- 94/9/EU "Devices and protection systems for use as prescribed in potentially explosive areas" (Guidelines for Explosion Protection)

The declarations of conformity are held at the disposal of the competent authorities at the address below:

Siemens Aktiengesellschaft
Bereich Automatisierungs- und Antriebstechnik
A&D AS RD4
Postfach 1963
D-92209 Amberg

UL approval



Underwriters Laboratories Inc. in accordance with

- UL 508 (Industrial Control Equipment)

CSA approval



Canadian Standards Association in accordance with

- C22.2 No. 142 (Process Control Equipment)

or

Underwriters Laboratories Inc. in accordance with



- UL 508 (Industrial Control Equipment)
- CSA C22.2 No. 142 (Process Control Equipment)

or



Underwriters Laboratories Inc. in accordance with

- UL 508 (Industrial Control Equipment)
- CSA C22.2 No. 142 (Process Control Equipment)
- UL 1604 (Hazardous Location)
- CSA-213 (Hazardous Location)

APPROVED for use in
Class I, Division 2, Group A, B, C, D Tx;
Class I, Zone 2, Group IIC Tx

Note

The currently applicable approvals can be found on the nameplate of the particular module.

FM approval



Factory Mutual Research (FM) in accordance with Approval Standard Class Number 3611, 3600, 3810 APPROVED for use in Class I, Division 2, Group A, B, C, D Tx; Class I, Zone 2, Group IIC Tx



in accordance with EN 50021 (Electrical apparatus for potentially explosive atmospheres; Type of protection "n")



II 3 G EEx nA II T4..T5

Identification for Australia



The S7-300 programmable logic controller meets the requirements of standard AS/NZS 2064 (Class A).

IEC 61131

The S7-300 programmable logic controller meets the requirements and criteria of standard IEC 61131-2 (Programmable Controllers, Part 2: Equipment Requirements and Tests).

Shipbuilding approval

Classification Societies:

- ABS (American Bureau of Shipping)
- BV (Bureau Veritas)
- DNV (Det Norske Veritas)
- GL (Germanischer Lloyd)
- LRS (Lloyds Register of Shipping)
- Class NK (Nippon Kaiji Kyokai)

Use in an industrial environment

SIMATIC products have been designed for use in an industrial environment.

Table 1-1 Use in an Industrial Environment

EMC Directive	Requirements in Respect of:	
	Emitted interference	Immunity
Industry	EN 61000-6-4: 2001	EN 61000-6-2: 2001

Use in residential environments

If you operate an S7-300 in a residential area, you must ensure Limit Value Class B in accordance with EN 55011 to guard against radio interference emissions.

Suitable measures to achieve interference suppression according to Limit Value Class B:

- installation of the S7-300 in grounded cabinets and control boxes
- use of filters in supply lines



Warning

Personal injury or property damage can result.

In areas subject to danger of explosion, personal injury or property damage can result if you withdraw connectors while an S7-300 is in operation.

Always isolate the S7-300 in areas subject to danger of explosion before withdrawing connectors.

1.2 Electromagnetic Compatibility

Introduction

In this section you will find details of the noise immunity of S7-300 modules and details of radio interference suppression.

The S7-300 modules satisfy, among other things, the requirements of the law applicable to EMC on the European domestic market.

Definition of "EMC"

Electromagnetic compatibility (EMC) is the ability of an electrical installation to function satisfactorily in its electromagnetic environment without interfering with that environment.

Pulse-shaped interference

The following table shows the electromagnetic compatibility of modules compared to pulse-shaped disturbance variables. A requirement for this is that the S7-300 system complies with the specifications and directives on electric design.

Table 1-2 Pulse-Shaped Interference

Pulse-Shaped Interference	Tested with	Satisfies Degree of Severity
Electrostatic discharge according to IEC 61000-4-2	Discharge in air: ± 8 kV Contact discharge: ± 4 kV	3
Bursts (fast transient bursts) to IEC 61000-4-4	2 kV (supply cable) 2 kV (signal cable > 3 m) 1 kV (signal cable < 3 m)	3
Energy-rich single impulse (surge) according to IEC 61000-4-5 External protective circuitry required (refer to the manual <i>S7-300 Programmable Controller, Hardware and Installation</i> , Chapter "Lightning Protection and Overvoltage Protection")	<ul style="list-style-type: none"> • Asymmetrical coupling <ul style="list-style-type: none"> 2 kV (supply cable) Direct voltage with protection elements 2 kV (signal/data cable only > 3 m) possibly with protection elements • Symmetrical coupling <ul style="list-style-type: none"> 1 kV (supply cable) Direct voltage with protection elements 1 kV (signal line only > 3 m) possibly with protection elements 	3

Additional measures

If you want to connect an S7-300 system to the public network, you must ensure **Limit Value Class B in accordance with EN 55022.**

Sinusoidal interference

The table below shows the EMC behavior of the S7-300 modules with regard to sinusoidal disturbance variables.

Table 1-3 Sinusoidal Interference

Sinusoidal Interference	Test values	Satisfies Degree of Severity
HF irradiation (electromagnetic fields) according to IEC 61000-4-3	10 V/m with 80% amplitude modulation of 1 kHz over the range from 80 MHz to 1000 MHz	3
according to IEC 61000-4-3	10 V/m with 50% pulse modulation at 900 MHz	
HF conductance on cables and cable shields according to IEC 61000-4-6	Test voltage 10 V with 80% amplitude modulation of 1 kHz over the range from 9 MHz to 80 MHz	3

Emission of radio interference

Interference emission of electromagnetic fields in accordance with EN 55011: Limit value class A, Group 1.

From 30 to 230 MHz	< 40 dB (μ V/m)Q
From 230 to 1000 MHz	< 47 dB (μ V/m)Q
Measured at a distance of 10 m (98.4 ft.)	

Interference emission via the mains AC power supply in accordance with EN 55011: Limit value class A, Group 1.

From 0.15 to 0.5 MHz	< 79 dB (μ V)Q < 66 dB (μ V)M
From 0.5 to 5 MHz	< 73 dB (μ V)Q < 60 dB (μ V)M
From 5 to 30 MHz	< 73 dB (μ V)Q < 60 dB (μ V)M

1.3 Shipping and Storage Conditions for Modules and Backup Batteries

Shipping and storage of modules

S7-300 modules surpass the requirements of IEC 61131-2, in respect of shipping and storage requirements. The following details apply to modules shipped and/or stored in their original packing.

Climatic conditions correspond to IEC 60721-3-3, Class 3K7 for storage and IEC 60721-3-2, Class 2K4 for transportation.

Mechanical conditions correspond to IEC 60721-3-2, Class 2M2.

Table 1-4 Shipping and Storage Conditions for Modules

Condition	Permitted Range
Free fall (in shipping packing)	$\leq 1\text{m}$
Temperature	from $-40\text{ }^{\circ}\text{C}$ to $+70\text{ }^{\circ}\text{C}$
Atmospheric pressure	1080 to 660 hPa (corresponding to an altitude of -1000 to 3500 m)
Relative humidity	10 to 95 %, no condensation
Sinusoidal oscillations to IEC 60068-2-6	5 – 9 Hz: 3.5 mm 9 – 150 Hz: 9.8 m/s^2
Shock according to IEC 60068-2-29	250 m/s^2 , 6 ms, 1000 shocks

Transporting backup batteries

Wherever possible, transport backup batteries in their original packing. Special approval does not have to be obtained for transporting backup batteries for S7-300 systems. The lithium content of the backup battery is approximately 0.25 g.

Storing backup batteries

Backup batteries must be stored in a cool and dry place. The maximum shelf life is 5 years.



Warning

Improper handling of backup batteries can result in injury and damage to property. If backup batteries are not treated properly, they can explode and cause severe burning.

Observe the following rules when handling backup batteries used in the S7-300 programmable logic controller:

- never charge them
 - never heat them
 - never throw them in the fire
 - never damage them mechanically (drill, squeeze, etc.)
-

1.4 Mechanical and Climatic Environmental Conditions for Operating S7-300s

Operating conditions

S7-300 systems are intended for stationary use in locations protected against the weather. The operating conditions surpass the requirements of DIN IEC 60721-3-3.

- Class 3M3 (mechanical requirements)
- Class 3K3 (climatic requirements)

Use with additional measures

The S7-300, for example, must **not** be used without taking additional measures:

- in locations exposed to a high degree of ionizing radiation
- in hostile environments caused, for instance, by
 - dust accumulation
 - corrosive vapors or gases
 - strong electric or magnetic fields
- in installations requiring special monitoring, for example
 - elevators
 - electrical installations in particularly hazardous areas

An additional measure might be, for instance, installation of the S7-300 in a cabinet or in a housing.

Ambient mechanical conditions

The ambient mechanical conditions for S7-300 modules are listed in the following table in the form of sinusoidal oscillations.

Table 1-5 Mechanical Conditions

Frequency Range in Hz	Continuous	Occasional
$10 \leq f \leq 58$	0.0375 mm amplitude	0.075 mm amplitude
$58 \leq f \leq 150$	0.5 g constant acceleration	1 g constant acceleration

Reducing vibrations

If your S7-300 modules are exposed to severe shock and/or vibrations, you must take the appropriate measures to reduce the acceleration and/or amplitude, respectively.

We recommend that you install the S7-300 on vibration-damping materials (for example, rubber-metal antivibration mountings).

Ambient mechanical conditions test

The following table contains important information on the type and scope of tests for ambient mechanical conditions.

Table 1-6 Ambient Mechanical Conditions Test

Test ...	Test Standard	Remarks
Vibrations	Vibration test according to IEC 60068 Part 2-6 (sinusoidal)	Type of oscillation: frequency sweeps with a rate of change of 1 octave/minute. $10 \text{ Hz} \leq f \leq 58 \text{ Hz}$, constant amplitude of 0.075 mm $58 \text{ Hz} \leq f \leq 150 \text{ Hz}$, constant acceleration of 1 g Duration of oscillation: 10 frequency sweeps per axis in each of three axes perpendicular to each other
Shock	Shock test to IEC 60068, Part 2-29	Type of shock: half-sine Severity of shock: 15 g peak value, 11 ms duration Direction of shock: 3 shocks each in the +/- direction in each of three axes perpendicular to each other

Climatic conditions

You can use S7-300s under the following climatic conditions:

Table 1-7 Climatic Conditions

Climatic Conditions	Permitted Range	Remarks
Temperature: horizontal installation: vertical installation:	from 0 to 60°C from 0 to 40°C	–
Relative humidity	10 to 95 %	Non-condensing, corresponds to relative humidity (RH) Class 2 according to IEC 61131, Part 2
Atmospheric pressure	1080 to 795 hPa	Corresponding to an altitude of –1000 to 2000 m
Concentration of contaminants	SO ₂ : < 0.5 ppm; RH < 60 %, non-condensing H ₂ S: < 0.1 ppm; RH < 60 %, non-condensing	Test: 10 ppm; 4 days Test: 1 ppm; 4 days

1.5 Information on Insulation Tests, Protection Class and Degree of Protection

Test voltages

Insulation stability must be demonstrated in the type test with the following test voltages in accordance with IEC 61131-2:

Table 1-8 Test Voltages

Circuits With Rated Voltage U_e to Other Circuits or to Ground	Test Voltage
< 50 V	500 VDC
< 150 V	2500 VDC
< 250 V	DC 4000 V

Protection class

Protection Class I according to IEC 60536 – in other words, protective conductor connection to rail necessary

Protection against ingress of foreign bodies and water

Degree of protection IP 20 according to IEC 60529, that is, protection against contact with standard probes.

There is no special protection against the ingress of water.

1.6 Rated Voltages of the S7-300

Rated operating voltages

The modules of the S7-300 operate with different rated voltages. The following table contains the rated voltages and the corresponding tolerances.

Table 1-9 Rated Voltages

Rated Voltage	Tolerance Range
24 VDC	20.4 to 28.8 VDC
120 VAC	93 to 132 VAC
230 VAC	187 to 264 VAC

1.7 SIMATIC Outdoor Modules

Definition

SIMATIC Outdoor modules are modules that can be used under extended environmental conditions. Extended environmental conditions mean:

- operation possible at temperatures from -25°C to $+60^{\circ}\text{C}$
- occasional, brief condensation permitted
- increased mechanical stress permissible

Comparison with "standard" modules

The functional scope and technical specifications for the SIMATIC Outdoor modules correspond to those of the "standard" modules.

The mechanical and climatic environmental conditions as well as their test method have changed.

The SIMATIC Outdoor modules have their own order numbers (refer to Table 1-10)

Configuring in *STEP 7*

If you have a *STEP 7* version in which the SIMATIC Outdoor modules are not contained in the hardware catalog, simply configure your system with the corresponding "standard" modules (refer to Table 1-10).

SIMATIC Outdoor Modules

The following table contains all SIMATIC Outdoor modules.

The order numbers of the corresponding "standard" modules have been included as an aid to configuration. You can refer to the description and technical specifications in the special section on the "standard" module.

Table 1-10 "SIMATIC Outdoor Modules"

Module	SIMATIC outdoor module for use under extended environmental conditions	"Standard" modules
	as of order no.	
IM 153-1	6ES7 153-1AA 82 -0XB0	6ES7 153-1AA02-0XB0
CPU 315-2 DP	6ES7 315-2AF 82 -0AB0	6ES7 315-2AF02-0AB0
CPU 312 IFM	6ES7 312-5AC 81 -0AB0	6ES7 312-5AC01-0AB0
CPU 314	6ES7 314-1AE 83 -0AB0	6ES7 314-1AE03-0AB0
CPU 314 IFM	6ES7 314-5AE 83 -0AB0	6ES7 314-5AE03-0AB0
IM 365	6ES7 365-0BA 81 -0AA0	6ES7 365-0BA01-0AA0
Power supply module		
PS 305	6ES7 305-1BA 80 -0AA0	---
PS 307	6ES7 307-1EA 80 -0AA0	6ES7 307-1EA00-0AA0
SM 321 digital input module;		
SM 321; DI 16 × 24 VDC	6ES7 321-1BH 82 -0AA0	6ES7 321-1BH02-0AA0
SM 321; DI 32 × 24 VDC	6ES7 321-1BL 80 -0AA0	6ES7 321-1BL00-0AA0
SM 321; DI 16 × 24 VDC	6ES7 321-7BH 80 -0AB0	6ES7 321-7BH00-0AB0
SM 321; DI 16 × 24 V-125 VDC	6ES7 321-1CH 80 -0AA0	---
SM 321; DI 8 × 120/230 VAC	6ES7 321-1FF 81 -0AA0	6ES7 321-1FF01-0AB0
SM 322 digital output module;		
SM 322; DO 16 × 24 VDC/0.5 A	6ES7 322-1BH 81 -0AA0	6ES7 322-1BH01-0AA0
SM 322; DO 8 × Rel. 230 VAC/5 A	6ES7 322-1HF 80 -0AA0	6ES7 322-1HF10-0AA0
SM 322; DO 8 × 48-125 VDC/1.5 A	6ES7 322-1CF 80 -0AA0	---
SM 322; DO 8 × 120/230 VAC/2 A	6ES7 322-1FF 81 -0AA0	6ES7 322-1FF01-0AA0
SM 322; DO 8 × 24 VDC/0.5 A	6ES7 322-8BF 80 -0AB0	6ES7 322-8BF00-0AB0
Digital Input/Output Module		
SM 323; DI8/DO8 × DC 24V/0.5A	6ES7 323-1BH 81 -0AA0	6ES7 323-1BH01-0AA0
Analog input module		
SM 331 analog input module; AI 2 × 12 bits	6ES7 331-7KB 82 -0AB0	6ES7 331-7KB02-0AB0
Analog output module		
SM 332 analog output module; AO 2 × 12 bits	6ES7 332-5HB 81 -0AB0	6ES7 332-5HB01-0AB0
SM 334 analog I/O module;		
SM 334; AI4/AO 2 × 12 bits	6ES7 334-0KE 80 -0AB0	6ES7 334-0KE00-0AB0

Table 1-10 "SIMATIC Outdoor Modules", continued

Module	SIMATIC outdoor module for use under extended environmental conditions	"Standard" modules
	as of order no.	
FEPROM 64 kByte memory card	6ES7 951-0KF80-0AA0	6ES7 951-0KF00-0AA0
FEPROM 32 kByte memory card	6ES7 951-0KE80-0AA0	6ES7 951-0KE00-0AA0
FEPROM 16 kByte memory card	6ES7 951-0KD80-0AA0	6ES7 951-0KD00-0AA0
Bus connector	6ES7 972-0BAx0-0XA0 6ES7 972-0BBx0-0XA0	

1.8 Mechanical and Climatic Environmental Conditions for Operating SIMATIC Outdoor Modules

Ambient mechanical conditions

Operating category: according to IEC 721 3-3, Class 3M4.

Ambient mechanical conditions test

The following table provides information about the type and extent of tests for mechanical ambient conditions on SIMATIC Outdoor modules.

Table 1-11 Outdoor Modules Ambient Mechanical Conditions Test

Test ...	Test Standard	Remarks
Vibrations	Vibration test according to IEC 6008 Part 2-6 (sinusoidal)	Type of oscillation: frequency sweeps with a rate of change of 1 octave/minute. 5 Hz ≤ f ≤ 9 Hz, constant amplitude of 3.5 mm 9 Hz ≤ f ≤ 150 Hz, constant acceleration of 1 g oscillation period: 10 frequency sweeps per axis in each of three axes perpendicular to each other
Shock	Shock test according to IEC 6008 Part 2-27	Type of shock: half-sine severity of shock: 15 g peak value, 11 ms duration Direction of shock: 3 shocks each in the +/- direction in each of three axes perpendicular to each other

Climatic conditions

The SIMATIC Outdoor modules can be used under the following climatic ambient conditions:

Operating category: according to IEC 721 3-3, Class 3K5.

Table 1-12 Outdoor Modules Climatic Conditions

Ambient Condition	Permitted Range	Remarks
Temperature: horizontal installation vertical installation	-25 °C to 60 °C -25 °C to 40 °C	–
Relative humidity	From 5 to 95 %	Occasional, brief condensation , corresponds to relative humidity (RH) Class 2 according to IEC 61131, Part 2
Atmospheric pressure	1080 to 795 hPa	Corresponds to a height of –1000 to 2000 m
Pollutant concentration (according to IEC 721 3-3; class 3C3)	SO ₂ : < 0.5 ppm; Relative humidity < 60% H ₂ S: < 0.1 ppm; Relative humidity < 60%	Test: 10 ppm; 4 days 1 ppm; 4 days

1.9 Use of the ET 200M / S7-300 in a Zone 2 Potentially Explosive Area

The following sections contain important information in the following languages.

In this chapter

Section	Topic
1.9.1	Einsatz der ET 200M / S7-300 im explosionsgefährdeten Bereich Zone 2
1.9.2	Use of the ET 200M / S7-300 in a Zone 2 Hazardous Area
1.9.3	Utilisation de l'ET 200M / S7-300 dans un environnement à risque d'explosion en zone 2
1.9.4	Aplicación del ET 200M / S7-300 en áreas con peligro de explosión, zona 2
1.9.5	Impiego dell'ET 200M / S7-300 nell'area a pericolo di esplosione zona 2
1.9.6	Gebruik van de ET 200M / S7-300 in het explosieve gebied zone 2
1.9.7	Brug af ET 200M / S7-300 i det eksplosionsfarlige område zone 2
1.9.8	ET 200M / S7-300:n käyttö räjähdysvaarannetuilla alueilla, vyöhyke 2
1.9.9	Användning av ET 200M / S7-300 i explosionsriskområde zon 2
1.9.10	Uso do ET 200M / S7-300 em área exposta ao perigo de explosão, zona 2
1.9.11	Χρήση της συσκευής ET 200M / S7-300 σε ...

1.9.1 Einsatz der ET 200M / S7-300 im explosionsgefährdeten Bereich Zone 2

Zone 2

Explosionsgefährdete Bereiche werden in Zonen eingeteilt. Die Zonen werden nach der Wahrscheinlichkeit des Vorhandenseins einer explosionsfähigen Atmosphäre unterschieden.

Zone	Explosionsgefahr	Beispiel
2	explosive Gasatmosphäre tritt nur selten und kurzzeitig auf	Bereiche um Flanschverbindungen mit Flachdichtungen bei Rohrleitungen in geschlossenen Räumen
sicherer Bereich	nein	<ul style="list-style-type: none">• außerhalb der Zone 2• Standardanwendungen von dezentraler Peripherie

Nachfolgend finden Sie wichtige Hinweise für die Installation des Dezentralen Peripheriegerätes ET 200M und der SIMATIC S7-300 im explosionsgefährdeten Bereich.

Weitere Informationen

Weitere Informationen zum ET 200M und zu den verschiedenen S7-300-Baugruppen finden Sie im Handbuch.

Fertigungsort

Siemens AG, Bereich A&D
Werner-von-Siemens-Straße 50
92224 Amberg
Germany

Zulassung

 II 3 G EEx nA II T3 .. T6 nach EN 50021 : 1999
Prüfnummer: **KEMA 02ATEX1096 X**

Hinweis

Baugruppen mit der Zulassung  II 3 G EEx nA II T3 .. T6 dürfen nur in Automatisierungssysteme SIMATIC S7-300 / ET 200M der Gerätekategorie 3 eingesetzt werden.

Instandhaltung

Für eine Reparatur muss die betroffene Baugruppe an den Fertigungsort geschickt werden. Nur dort darf die Reparatur durchgeführt werden.

Besondere Bedingungen

1. Das Dezentrale Peripheriegerät ET 200M und die SIMATIC S7-300 müssen in einen Schaltschrank oder ein metallisches Gehäuse eingebaut werden. Diese müssen mindestens die Schutzart IP 54 (nach EN 60529) gewährleisten. Dabei sind die Umgebungsbedingungen zu berücksichtigen, in denen das Gerät installiert wird. Für das Gehäuse muss eine Herstellererklärung für Zone 2 vorliegen (gemäß EN 50021).
2. Wenn am Kabel bzw. an der Kabeleinführung dieses Gehäuses unter Betriebsbedingungen eine Temperatur $> 70\text{ °C}$ erreicht wird oder wenn unter Betriebsbedingungen die Temperatur an der Aderverzweigung $> 80\text{ °C}$ sein kann, müssen die Temperatureigenschaften der Kabel mit den tatsächlich gemessenen Temperaturen übereinstimmen.
3. Die eingesetzten Kabeleinführungen müssen der geforderten IP-Schutzart und dem Abschnitt 7.2 (gemäß EN 50021) entsprechen.
4. Alle Geräte, einschließlich Schalter etc., die an den Ein- und Ausgängen von ET 200M- und S7-300-Systemen angeschlossen werden, müssen für den Explosionsschutz Typ EEx nA oder EEx nC genehmigt sein.
5. Es müssen Maßnahmen getroffen werden, dass die Nennspannung durch Transienten um nicht mehr als 40 % überschritten werden kann.
6. Umgebungstemperaturbereich: 0 °C bis 60 °C
7. Innerhalb des Gehäuses ist an einem nach dem Öffnen gut sichtbaren Platz ein Schild mit folgender Warnung anzubringen:
Warnung
Das Gehäuse darf nur kurze Zeit geöffnet werden, z. B. für visuelle Diagnose. Betätigen Sie dabei keine Schalter, ziehen oder stecken keine Baugruppen und trennen keine elektrischen Leitungen (Steckverbindungen). Diese Warnung kann unberücksichtigt bleiben, wenn bekannt ist, dass keine explosionsgefährdete Atmosphäre herrscht.

Liste der zugelassenen Baugruppen

Die Liste mit den zugelassenen Baugruppen finden Sie im Internet:

<http://www4.ad.siemens.de/view/cs/>

unter der Beitrags-ID 13702947

1.9.2 Use of the ET 200M / S7-300 in a Zone 2 Hazardous Area

Zone 2

Hazardous areas are divided up into zones. The zones are distinguished according to the probability of the existence of an explosive atmosphere.

Zone	Explosion Hazard	Example
2	Explosive gas atmosphere occurs only seldom and for a short time	Areas around flange joints with flat gaskets in pipes in enclosed spaces
Safe area	No	<ul style="list-style-type: none">• Outside zone 2• Standard distributed I/O applications

Below you will find important information on the installation of the ET 200M distributed I/O device and the SIMATIC S7-300 in a hazardous area.

Further Information

You will find further information on the ET 200M and the various S7-300 modules in the manual.

Production Location

Siemens AG, Bereich A&D
Werner-von-Siemens-Straße 50
92224 Amberg
Germany

Certification

 II 3 G EEx nA II T3 .. T6 to EN 50021 : 1999

Test number: **KEMA 02ATEX1096 X**

Note

Modules with  II 3 G EEx nA II T3 .. T6 certification can only be used in SIMATIC S7-300/ET 200M automation systems belonging to equipment category 3.

Maintenance

If repair is necessary, the affected module must be sent to the production location. Repairs can only be carried there.

Special Conditions

1. The ET 200M distributed I/O device and the SIMATIC S7-300 must be installed in a cabinet or metal housing. These must comply with the IP 54 degree of protection as a minimum. The environmental conditions under which the equipment is installed must be taken into account. There must be a manufacturer's declaration for zone 2 available for the housing (in accordance with EN 50021).
2. If a temperature of $> 70\text{ }^{\circ}\text{C}$ is reached in the cable or at the cable entry of this housing under operating conditions, or if a temperature of $> 80\text{ }^{\circ}\text{C}$ can be reached at the junction of the conductors under operating conditions, the temperature-related properties of the cables must correspond to the temperatures actually measured.
3. The cable entries used must comply with the required IP degree of protection and Section 7.2 (in accordance with EN 50021).
4. All devices (including switches, etc.) that are connected to the inputs and outputs of fail-safe signal modules must be approved for EEx nA or EEx nC explosion protection.
5. Steps must be taken to ensure that the rated voltage through transients cannot be exceeded by more than 40 %.
6. Ambient temperature range: 0°C to 60°C
7. A sign containing the following warning must be put up inside the housing in an easily visible position when the housing is opened:
Warning
The housing can only be opened for a short time (e.g. for visual diagnostics). If you do this, do not operate any switches, remove or install any modules or disconnect any electrical cables (plug-in connections).
You can disregard this warning if you know that the atmosphere is not hazardous (i.e. there is no risk of explosion).

List of Approved Modules

You will find the list of approved modules under the ID 13702947 on the Internet:

<http://www4.ad.siemens.de/view/cs/>.

1.9.3 Utilisation de l'ET 200M / S7-300 dans un environnement à risque d'explosion en zone 2

Zone 2

Les environnements à risque d'explosion sont répartis en zones. Les zones se distinguent par la probabilité de présence d'une atmosphère explosive.

Zone	Risque d'explosion	Exemple
2	Formation rare et brève d'une atmosphère gazeuse explosive	Environnement de raccords à joints plats dans le cas de conduites dans des locaux fermés
Zone sûre	Non	<ul style="list-style-type: none"> • A l'extérieur de la zone 2 • Utilisation standard de périphérie décentralisée

Vous trouverez ci-après des remarques importantes pour l'installation de la station de périphérie décentralisée ET 200M et du SIMATIC S7-300 dans un environnement présentant un risque d'explosion.

Informations complémentaires

Des informations complémentaires sur l'ET 200M et les divers modules S7-300 se trouvent dans le manuel.

Lieu de production

Siemens AG, Bereich A&D
 Werner-von-Siemens-Straße 50
 92224 Amberg
 Germany

Homologation

 II 3 G EEx nA II T3 .. T6 selon EN 50021 : 1999

Numéro de contrôle : **KEMA 02ATEX1096 X**

Nota

Les modules homologués  II 3 G EEx nA II T3 .. T6 ne peuvent être utilisés que dans des automates SIMATIC S7-300 / ET 200M de catégorie 3.

Entretien

Si une réparation est nécessaire, le module concerné doit être expédié au lieu de production. La réparation ne doit être effectuée qu'en ce lieu.

Conditions particulières

1. La station de périphérie décentralisée ET 200M et le SIMATIC S7-300 doivent être installés dans une armoire ou un boîtier métallique. Ceux-ci doivent assurer au moins l'indice de protection IP 54. Il faut alors tenir compte des conditions d'environnement dans lesquelles l'appareil est installé. Le boîtier doit faire l'objet d'une déclaration de conformité du fabricant pour la zone 2 (selon EN 50021).
2. Si dans les conditions d'exploitation, une température > 70 °C est atteinte au niveau du câble ou de l'entrée du câble dans ce boîtier, ou bien si la température au niveau de la dérivation des conducteurs peut être > 80 °C, les capacités de résistance thermique des câbles doivent correspondre aux températures effectivement mesurées.
3. Les entrées de câbles utilisées doivent avoir le niveau de protection IP exigé et être conformes au paragraphe 7.2 (selon EN 50021).
4. Tous les appareillages (y compris les interrupteurs, etc.) raccordés aux entrées et sorties de modules de signaux à sécurité intrinsèque doivent être homologués pour la protection antidéflagrante type EEx nA ou EEx nC.
5. Il faut prendre des mesures pour que la tension nominale ne puisse pas être dépassée de plus de 40% sous l'influence de transitoires.
6. Plage de température ambiante : 0° C à 60° C
7. A l'intérieur du boîtier, il faut placer, à un endroit bien visible après ouverture, une plaquette comportant l'avertissement suivant :
Avertissement
Ouvrir le boîtier le moins longtemps possible, par exemple pour effectuer un diagnostic visuel. Ce faisant, n'actionnez aucun commutateur, ne déconnectez aucun module et ne débanchez pas de câbles électriques (connexions).
Le respect de cet avertissement n'est pas impératif s'il est certain que l'environnement ne présente pas de risque d'explosion.

Liste des modules homologués

Vous trouverez sur Internet la liste des modules homologués :

<http://www4.ad.siemens.de/view/cs/>

référence ID 13702947

1.9.4 Aplicación de la ET 200M / S7-300 en áreas con peligro de explosión, zona 2

Zona 2

Las áreas con peligro de explosión se clasifican en zonas. Las zonas se diferencian según la probabilidad de la existencia de una atmósfera capaz de sufrir una explosión.

Zona	Peligro de explosión	Ejemplo
2	La atmósfera explosiva de gas sólo se presenta rara vez y muy brevemente	Áreas alrededor de uniones abridadas con juntas planas en tuberías en locales cerrados
Área segura	No	<ul style="list-style-type: none">• fuera de la zona 2• Aplicaciones estándar de la periferia descentralizada

A continuación encontrará importantes informaciones para la instalación de la unidad periférica descentralizada ET 200M y del SIMATIC S7-300 en áreas con peligro de explosión.

Otras informaciones

Encontrará otras informaciones relativas a la ET 200S y a los distintos módulos S7-300 en el Manual.

Lugar de fabricación

Siemens AG, Bereich A&D
Werner-von-Siemens-Straße 50
92224 Amberg
Germany

Homologación

 II 3 G EEx nA II T3 .. T6 según norma EN 50021 : 1999

Número de comprobación: **KEMA 02ATEX1096 X**

Nota

Los módulos con la homologación  II 3 G EEx nA II T3 .. T6 pueden utilizarse únicamente en los autómatas programables SIMATIC S7-300 / ET 200M de la categoría de equipo 3.

Mantenimiento

Para una reparación se ha de remitir el módulo afectado al lugar de fabricación. Sólo allí se puede realizar la reparación.

Condiciones especiales

1. La unidad periférica descentralizada ET 200M y el SIMATIC S7-300 se han de montar en un armario eléctrico de distribución o en una carcasa metálica. Éstos deben garantizar como mínimo el grado de protección IP 54. Para ello se han de tener en cuenta las condiciones ambientales, en las cuales se instala el equipo. La caja deberá contar con una declaración del fabricante para la zona 2 (conforme a EN 50021).
2. Si durante la operación se alcanzara una temperatura $> 70^{\circ}\text{C}$ en el cable o la entrada de cables de esta caja o bien una temperatura $> 80^{\circ}\text{C}$ en la bifurcación de hilos, deberán adaptarse las propiedades térmicas de los cables a las temperaturas medidas efectivamente.
3. Las entradas de cable utilizadas deben cumplir el grado de protección IP exigido y lo expuesto en el apartado 7.2 (conforme a EN 50021).
4. Todos los dispositivos –inclusive interruptores, etc.– conectados a las entradas y salidas de módulos de señales de alta disponibilidad deben estar homologados para la protección contra explosiones del tipo EEx nA o EEx nC.
5. Es necesario adoptar las medidas necesarias para evitar que la tensión nominal pueda rebasar en más del 40 % debido a efectos transitorios.
6. Margen de temperatura ambiente: 0°C hasta 60°C
7. Dentro de la caja deberá colocarse en un lugar perfectamente visible tras su apertura un rótulo con la siguiente advertencia:
Precaución
Abrir la caja sólo brevemente, p.ej. para el diagnóstico visual. Durante este tiempo Ud. no deberá activar ningún interruptor, desenchufar o enchufar módulos ni separar conductores eléctricos (conexiones enchufables). Esta advertencia puede ignorarse si Ud. sabe que en la atmósfera existente no hay peligro de explosión.

Lista de los módulos homologados

En la internet hallará Ud. una lista con los módulos homologados:

<http://www4.ad.siemens.de/view/cs/>

bajo el ID de asignación 13702947

1.9.5 Impiego dell'ET 200M / S7-300 nell'area a pericolo di esplosione zona 2

Zona 2

Le aree a pericolo di esplosione vengono suddivise in zone. Le zone vengono distinte secondo la probabilità della presenza di un'atmosfera esplosiva.

Zona	Pericolo di esplosione	Esempio
2	L'atmosfera esplosiva si presenta solo raramente e brevemente	Aree intorno a collegamenti a flange con guarnizioni piatte nelle condotte in ambienti chiusi
Area sicura	No	<ul style="list-style-type: none">• Al di fuori della zona 2• Applicazioni standard di periferia decentrata

Qui di seguito sono riportate delle avvertenze importanti per l'installazione dell'unità di periferia decentrata ET 200M e del SIMATIC S7-300 nell'area a pericolo di esplosione.

Ulteriori informazioni

Ulteriori informazioni sull'ET 200M e sulle diverse unità S7-300 si trovano nel manuale.

Luogo di produzione

Siemens AG, Bereich A&D
Werner-von-Siemens-Straße 50
92224 Amberg
Germany

Autorizzazione

 II 3 G EEx nA II T3 .. T6 secondo EN 50021 : 1999

Numero di controllo: **KEMA 02ATEX1096 X**

Avvertenza

Le unità con l'autorizzazione  II 3 G EEx nA II T3 .. T6 possono essere impiegate solo nei sistemi di controllori programmabili SIMATIC S7-300 / ET 200M della categoria di apparecchiature 3.

Manutenzione

Per una riparazione, l'unità interessata deve essere inviata al luogo di produzione. La riparazione può essere effettuata solo lì.

Condizioni particolari

1. L'unità di periferia decentrata ET 200M e il SIMATIC S7-300 devono essere montati in un armadio elettrico o in un contenitore metallico. Questi devono assicurare almeno il tipo di protezione IP 54. In questo caso bisogna tenere conto delle condizioni ambientali nelle quali l'apparecchiatura viene installata. Per il contenitore deve essere presente una dichiarazione del costruttore per la zona 2 (secondo EN 50021).
2. Se nei cavi o nel loro punto di ingresso in questo contenitore viene raggiunta in condizioni di esercizio una temperatura $> 70\text{ }^{\circ}\text{C}$ o se in condizioni di esercizio la temperatura nella derivazione dei fili può essere $> 80\text{ }^{\circ}\text{C}$, le caratteristiche di temperatura dei cavi devono essere conformi alla temperatura effettivamente misurata.
3. Gli ingressi dei cavi usati devono essere conformi al tipo di protezione richiesto e alla sezione 7.2 (secondo EN 50021).
4. Tutte le apparecchiature, inclusi interruttori, ecc. che vengono collegati agli ingressi/uscite di unità di segnale ad elevata sicurezza, devono essere stati omologati per la protezione da esplosione tipo EEx nA o EEx nC.
5. Devono essere prese delle misure per evitare che la tensione nominale possa essere superata per più del 40% da parte di transienti.
6. Campo termico ambientale: da 0°C a 60°C
7. All'interno del contenitore va apportata, in un luogo ben visibile dopo l'apertura, una targhetta con il seguente avvertimento:
Attenzione
Il contenitore può rimanere aperto solo per breve tempo, ad esempio per una diagnostica a vista. In tal caso non azionare alcun interruttore, non disinnestare o innestare unità e non staccare connessioni elettriche (connettori).
Non è necessario tenere conto di questo avvertimento se è noto che non c'è un'atmosfera a rischio di esplosione.

Elenco delle unità abilitate

La lista con le unità omologate si trova in Internet al sito:

<http://www4.ad.siemens.de/view/cs/>

all'ID di voce 13702947

1.9.6 Gebruik van de ET 200M / S7-300 in het explosief gebied zone 2

Zone 2

Explosieve gebieden worden ingedeeld in zones. Bij de zones wordt onderscheiden volgens de waarschijnlijkheid van de aanwezigheid van een explosieve atmosfeer.

Zone	Explosiegevaar	Voorbeeld
2	Een explosieve gasatmosfeer treedt maar zelden op en voor korte duur	Gebieden rond flensverbindingen met pakkingen bij buisleidingen in gesloten vertrekken
Veilig gebied	Neen	<ul style="list-style-type: none">• Buiten de zone 2• Standaardtoepassingen van decentrale periferie

Hierna vindt u belangrijke aanwijzingen voor de installatie van het decentrale periferieapparaat ET 200M en van de SIMATIC S7-300 in het explosief gebied.

Verdere informatie

In het handboek vindt u verdere informatie over de ET 200M en over de verschillende S7-300-modulen.

Productieplaats

Siemens AG, Bereich A&D
Werner-von-Siemens-Strasse 50
92224 Amberg
Germany

Vergunning

 II 3 G EEx nA II T3 .. T6 conform EN 50021 : 1999

Keuringsnummer: **KEMA 02ATEX1096 X**

Opmerking

Modulen met de vergunning  II 3 G EEx nA II T3 .. T6 mogen slechts worden gebruikt in automatiseringssystemen SIMATIC S7-300 / ET 200M van de apparaatcategorie 3.

Instandhouding

Voor een reparatie moet de betreffende module naar de plaats van vervaardiging worden gestuurd. Alleen daar mag de reparatie worden uitgevoerd.

Speciale voorwaarden

1. Het decentrale periferieapparaat ET 200M en de SIMATIC S7-300 moeten worden ingebouwd in een schakelkast of in een behuizing van metaal. Deze moeten minstens de veiligheidsgraad IP 54 waarborgen. Hierbij dient rekening te worden gehouden met de omgevingsvoorwaarden waarin het apparaat wordt geïnstalleerd. Voor de behuizing dient een verklaring van de fabrikant voor zone 2 te worden ingediend (volgens EN 50021).
2. Als aan de kabel of aan de kabelinvoering van deze behuizing onder bedrijfsomstandigheden een temperatuur wordt bereikt $> 70\text{ °C}$ of als onder bedrijfsomstandigheden de temperatuur aan de adervertakking $> 80\text{ °C}$ kan zijn, moeten de temperatuureigenschappen van de kabel overeenstemmen met de werkelijk gemeten temperaturen.
3. De aangebrachte kabelinvoeringen moeten de vereiste IP-veiligheidsgraad hebben en in overeenstemming zijn met alinea 7.2 (volgens EN 50021).
4. Alle apparaten, schakelaars enz. inbegrepen, die worden aangesloten op de in- en uitgangen van tegen fouten beveiligde signaalmodulen, moeten zijn goedgekeurd voor de explosiebeveiliging type EEx nA of EEx nC.
5. Er dienen maatregelen te worden getroffen, zodat de nominale spanning door transiënten met niet meer dan 40 % kan worden overschreden.
6. Omgevingstemperatuurbereik: 0 °C tot 60 °C
7. Binnen de behuizing dient op een na het openen goed zichtbare plaats een bord te worden aangebracht met de volgende waarschuwing:
Waarschuwing
De behuizing mag slechts voor korte tijd worden geopend, bijv. voor een visuele diagnose. Bedien hierbij geen schakelaar, trek of steek geen modulen en ontkoppel geen elektrische leidingen (steekverbindingen).
Deze waarschuwing kan buiten beschouwing blijven, indien bekend is dat er geen explosieve atmosfeer heerst.

Lijst van de toegelaten modulen

De lijst met de toegelaten modulen vindt u in het internet:

<http://www4.ad.siemens.de/view/cs/>

onder de bijdrage-ID 13702947

1.9.7 Brug af ET 200M / S7-300 i det eksplosionsfarlige område zone 2

Zone 2

Eksplionsfarlige områder inddeles i zoner. Zonerne adskiller sig indbyrdes efter hvor sandsynligt det er, at der er en eksplosiv atmosfære.

Zone	Eksplionsfare	Eksempel
2	Eksplions gasatmosfære optræder kun sjældent og varer kort	Områder rundt om flangeforbindelser med flade pakninger ved rørledninger i lukkede rum
Sikkert område	Nej	<ul style="list-style-type: none">• Uden for zone 2• Standardanvendelser decentral periferi

I det følgende findes vigtige henvisninger vedr. installation af det decentrale periferiudstyr ET 200M og SIMATIC S7-300 i det eksplosionsfarlige område.

Yderligere informationer

Yderligere informationer om ET 200M og de forskellige S7-300-komponenter findes i manualen.

Produktionssted

Siemens AG, Bereich A&D
Werner-von-Siemens-Straße 50
92224 Amberg
Germany

Godkendelse

 II 3 G EEx nA II T3 .. T6 efter EN 50021 : 1999

Kontrolnummer: **KEMA 02ATEX1096 X**

Bemærk

Komponenter med godkendelsen  II 3 G EEx nA II T3 .. T6 må kun monteres i automatiseringssystemer SIMATIC S7-300 / ET 200M - udstyrskategori 3.

Vedligeholdelse

Skal den pågældende komponent repareres, bedes De sende den til produktionsstedet. Reparation må kun udføres der.

Særlige betingelser

1. Det decentrale periferiudstyr ET 200M og SIMATIC S7-300 skal monteres i et kontrolskab eller et metalkabinet. Disse skal mindst kunne sikre beskyttelsesklasse IP 54. I denne forbindelse skal der tages højde for de omgivelsestemperaturer, i hvilke udstyret er installeret. Der skal være udarbejdet en erklæring fra fabrikanten for kabinettet for zone 2 (iht. EN 50021).
2. Hvis kablet eller kabelindføringen på dette hus når op på en temperatur på $> 70^{\circ}\text{C}$ under driftsbetingelser eller hvis temperaturen på åreforegreningen kan være $> 80^{\circ}\text{C}$ under driftsbetingelser, skal kablernes temperaturegenskaber stemme overens med de temperaturer, der rent faktisk måles.
3. De benyttede kabelindføringer skal være i overensstemmelse med den krævede IP-beskyttelsestype og afsnittet 7.2 (iht. EN 50021).
4. Alle apparater, inkl. kontakter osv., der forbindes med ind- og udgangene til fejlsikre signalkomponenter, skal være godkendt til eksplosionsbeskyttelse af type EEx nA eller EEx nC.
5. Der skal træffes foranstaltninger, der sørger for, at den nominelle spænding via transienter ikke kan overskrides mere end 40 %.
6. Omgivelsestemperaturområde: 0°C til 60°C
7. I kabinettet skal der anbringes et skilt, der skal kunne ses, når kabinettet åbnes. Dette skilt skal have følgende advarsel:
Advarsel
Kabinettet må kun åbnes i kort tid, f.eks. til visuel diagnose. Tryk i denne forbindelse ikke på kontakter, træk eller isæt ikke komponenter og afbryd ikke elektriske ledninger (stikforbindelser).
Denne advarsel skal der ikke tages højde for, hvis man ved, at der ikke er nogen eksplosionsfarlig atmosfære.

Liste over godkendte komponenter

Listen med de godkendte komponenter findes på internettet:

<http://www4.ad.siemens.de/view/cs/>

under bidrags-ID 13702947

1.9.8 ET 200M / S7-300:n käyttö räjähdysvaarannetuilla alueilla, vyöhyke 2

Vyöhyke 2

Räjähdysvaarannetut alueet jaetaan vyöhykkeisiin. Vyöhykkeet erotellaan räjähdyskelpoisen ilmakehän olemassa olon todennäköisyyden mukaan.

Vyöhyke	Räjähdysvaara	Esimerkki
2	Räjähtävä kaasuilmakehä ilmaantuu vain harvoin ja lyhytaikaisesti	Alueet putkistojen lattatiivisteillä varustuilla laippaliitoksilla suljetuissa tiloissa
turvallinen alue	Ei	<ul style="list-style-type: none">vyöhykkeen 2 ulkopuolellaHajautetun ulkopiirin vakiosovellukset

Seuraavasta löydätte tärkeitä ohjeita hajautetun ulkopiirilaitteen ET 200M ja SIMATIC S7-300 asennukseen räjähdysvaarannetuilla alueilla.

Lisätietoja

Lisätietoja ET 200M:ään ja erilaisiin S7-300-rakenneryhmiin löydätte ohjekirjasta.

Valmistuspaikka

Siemens AG, Bereich A&D
Werner-von-Siemens-Straße 50
92224 Amberg
Germany

Hyväksyntä

 II 3 G EEx nA II T3 .. T6 EN 50021 mukaan: 1999

Tarkastusnumero: **KEMA 02ATEX1096 X**

Ohje

Rakenneryhmät hyväksynnän  II 3 G EEx nA II T3 .. T6 kanssa saadaan käyttää ainoastaan laitekategorian 3 automatisointijärjestelmissä SIMATIC S7-300 / ET 200M.

Kunnossapito

Korjausta varten täytyy kyseinen rakenneryhmä lähettää valmistuspaikkaan. Korjaus voidaan suorittaa ainoastaan siellä.

Erityiset vaatimukset

1. Hajautettu ulkopiirilaite ET 200M ja SIMATIC S7-300 täytyy asentaa kytkentäkaappiin tai metalliseen koteloon. Näiden täytyy olla vähintään kotelointiluokan IP 54 mukaisia. Tällöin on huomioitava ympäristöolosuhteet, johon laite asennetaan. Kotelolle täytyy olla valmistajaselvitys vyöhykettä 2 varten (EN 50021 mukaan).
2. Kun johdolla tai tämän kotelon johdon sisäänviennillä saavutetaan $> 70^{\circ}\text{C}$ lämpötila tai kun käyttöolosuhteissa lämpötila voi pihajajaotuksella olla $> 80^{\circ}\text{C}$, täytyy johdon lämpötilaominaisuuksien vastata todellisesti mitattuja lämpötiloja.
3. Käytettyjen johtojen sisäänohjauksien täytyy olla vaaditun IP-kotelointiluokan ja kohdan 7.2 (EN 50021 mukaan) mukaisia.
4. Kaikkien laitteiden, kytkimet jne. mukaan lukien, jotka liitetään virheiltä suojattujen signaalirakenneryhmien tuloille ja lähdöille, täytyy olla hyväksytyjä tyyppin EEx nA tai EEx nC räjähdysvaarasta varten.
5. Toimenpiteet täytyy suorittaa, ettei nimellisjännite voi transienttien kautta ylittyä enemmän kuin 40 %.
6. Ympäristölämpötila-alue: $0^{\circ}\text{C} \dots 60^{\circ}\text{C}$
7. Kotelon sisälle, avauksen jälkeen näkyvälle paikalle, on kiinnitettävä kilpi, jossa on seuraava varoitus:
Varoitus
Kotelo saadaan avata ainoastaan lyhyeksi ajaksi, esim. visuaalista diagnoosia varten. Älä tällöin käytä mitään kytkimiä, vedä tai liitä mitään rakenneryhmiä, äläkä erota mitään sähköjohtoja (pistoliittimiä).
Tätä varoitusta ei tarvitse huomioida, kun on tiedossa, että minkäänlaista räjähdysvaarannettua ilmakehää ei ole olemassa.

Hyväksytyjen rakenneryhmien lista

Lista hyväksytyistä rakennesarjoista löytyy internetistä osoitteesta:

<http://www4.ad.siemens.de/view/cs/>

käyttäjätunnuksella 13702947

1.9.9 Användning av ET 200M / S7-300 i explosionsriskområde zon 2

Zon 2

Explosionsriskområden delas in i zoner. Zonerna delas in enligt sannolikheten att en atmosfär med explosionsfara föreligger.

Zon	Explosionsfara	Exempel
2	Explosiv gasatmosfär uppstår endast sällan eller kortvarigt	Områden kring flänsförbindelser med packningar vid rörledningar i slutna utrymmen
Säkert område	Nej	<ul style="list-style-type: none">• Utanför zon 2• Standardanvändning av decentral periferi

Nedan följer viktiga anvisningar om installationen av den decentrala periferienheten ET 200M och SIMATIC°S7-300 i ett explosionsriskområde.

Ytterligare information

Ytterligare information om ET 200M och de olika S7-300-komponentgrupperna finner du i handboken.

Tillverkningsort

Siemens AG, Bereich A&D
Werner-von-Siemens-Straße 50
92224 Amberg
Germany

Godkännande

 II 3 G EEx nA II T3 .. T6 enligt EN 50021 : 1999

Kontrollnummer: **KEMA 02ATEX1096 X**

Anvisning

Komponentgrupper med godkännande  II 3 G EEx nA II T3 .. T6 får endast användas i automatiseringssystemen SIMATIC S7-300 / ET°200M från apparatgrupp 3.

Underhåll

Vid reparation måste den aktuella komponentgruppen insändas till tillverkaren. Reparationer får endast genomföras där.

Särskilda villkor

1. Den decentrala periferienheten ET 200M och SIMATIC°S7-300 måste monteras i ett kopplingskåp eller metallhus. Dessa måste minst vara av skyddsklass IP 54. Därvid ska omgivningsvillkoren där enheten installeras beaktas. För kåpan måste en tillverkardeklaration för zon 2 föreligga (enligt EN 50021).
2. Om en temperatur på $> 70^{\circ}\text{C}$ uppnås vid husets kabel resp kabelinföring under driftvillkor eller om temperaturen vid trådförgreningen kan vara $> 80^{\circ}\text{C}$ under driftvillkor, måste kabelns temperaturegenskaper överensstämma med den verkliga uppmätta temperaturen.
3. De använda kabelinföringarna måste uppfylla kraven i det krävda IP-skyddsutförandet och i avsnitt 7.2 (enligt EN 50021).
4. Alla apparater, inklusive brytare osv, som ansluts till felsäkrade signalenheters in- och utgångar, måste vara godkända för explosionsskydd av typ EEx nA eller EEx nC.
5. Åtgärder måste vidtas så, att märkspänningen ej kan överskridas med mer än 40% genom transienter.
6. Omgivningstemperatur: 0°C till 60°C
7. När huset öppnats ska en skylt med följande varning monteras på ett tydligt synligt ställe huset:
Varning
Huset får endast öppnas under kort tid, t ex för visuell diagnos. Använd därvid inga brytare, lossa eller anslut inga enheter och frånskilj inga elektriska ledningar (insticksanslutningar).
Ingen hänsyn måste tas till denna varning om det är säkert att det inte råder någon explosionsfarlig atmosfär.

Lista över godkända komponentgrupper

Lista över godkända enheter återfinns i Internet:

<http://www4.ad.siemens.de/view/cs/>

under bidrags-ID 13702947

1.9.10 Uso do ET 200M / S7-300 em área exposta ao perigo de explosão 2

Zona 2

As áreas expostas ao perigo de explosão são divididas em zonas. As zonas são diferenciadas de acordo com a probabilidade da existência de uma atmosfera explosiva.

Zona	Perigo de explosão	Exemplo
2	Só raramente e por um breve período de tempo surgem atmosferas explosivas	Áreas em torno de ligações flangeadas com vedações chatas em tubulações em recintos fechados
Área segura	Não	<ul style="list-style-type: none">• fora da zona 2• Aplicações descentralizadas de periferia descentralizada

A seguir, o encontrará avisos importantes para a instalação do aparelho periférico descentralizado ET 200M e da SIMATIC S7-300 em área exposta ao perigo de explosão.

Mais informações

Para obter mais informações sobre o ET 200M e os diversos grupos construtivos S7-300, consulte o manual.

Local de produção

Siemens AG, Bereich A&D
Werner-von-Siemens-Straße 50
92224 Amberg
Germany

Licença

 II 3 G EEx nA II T3 .. T6 seg. EN 50021 : 1999

Número de ensaio: **KEMA 02ATEX1096 X**

Aviso

Componentes com a licença  II 3 G EEx nA II T3 .. T6 só podem ser aplicados em sistemas de automação SIMATIC S7-300 / ET 200M da categoria de aparelho 3.

Reparo

Os grupos construtivos em questão devem ser remetidos para o local de produção a fim de que seja realizado o reparo. Apenas lá deve ser efetuado o reparo.

Condições especiais

1. O aparelho periférico ET 200M e a SIMATIC S7-300 devem ser montados em um armário de distribuição ou em uma caixa metálica. Estes devem garantir no mínimo o tipo de proteção IP 54. Durante este trabalho deverão ser levados em consideração as condições locais, nas quais o aparelho será instalado. Para a caixa deverá ser apresentada uma declaração do fabricante para a zona 2 (de acordo com EN 50021).
2. Caso no cabo ou na entrada do cabo desta carcaça sob as condições operacionais seja atingida uma temperatura de $> 70^{\circ}\text{C}$, ou caso sob condições operacionais a temperatura na ramificação do fio poderá atingir $> 80^{\circ}\text{C}$, as características de temperatura deverão corresponder às temperaturas realmente medidas.
3. As entradas de cabo utilizadas devem corresponder ao tipo exigido de proteção IP e à seção 7.2 (de acordo com o EN 50021).
4. Todos os aparelhos, inclusive as chaves, etc., que estejam conectadas em entradas e saídas de módulos de sinais protegidos contra erro, devem possuir a licença para a proteção de explosão do tipo EEx nA ou EEx nC.
5. Precisam ser tomadas medidas para que a tensão nominal através de transitórios não possa ser ultrapassada em mais que 40 %.
6. Área de temperatura ambiente: 0°C até 60°C
7. No âmbito da carcaça deve ser colocada, após a abertura, em um ponto bem visível uma placa com a seguinte advertência:
Advertência
A carcaça deve ser aberta apenas por um breve período de tempo, por ex. para diagnóstico visual. Não acione nenhum interruptor, não retire ou conecte nenhum módulo e não separe nenhum fio elétrico (ligações de tomada). Esta advertência poderá ser ignorada caso se saiba que não há nenhuma atmosfera sujeita ao perigo de explosão.

Lista dos componentes autorizados

A lista com os módulos autorizados encontram-se na Internet:

<http://www4.ad.siemens.de/view/cs/>

sob o número de ID 13702947

1.9.11 Χρήση της συσκευής ET 200M / S7-300 σε επικίνδυνη για έκρηξη περιοχή, ζώνη 2

Ζώνη 2

Οι επικίνδυνες για έκρηξη περιοχές χωρίζονται σε ζώνες. Οι ζώνες διαφέρουν σύμφωνα με την πιθανότητα ύπαρξης ενός ικανού για έκρηξη περιβάλλοντος.

Ζώνη	Κίνδυνος έκρηξης	Παράδειγμα
2	Εκρηκτικό περιβάλλον αερίου παρουσιάζεται μόνο σπάνια και για σύντομο χρονικό διάστημα	Περιοχές γύρω από φλαντζωτές συνδέσεις με τσιμούχες σε σωληνώσεις σε κλειστούς χώρους
Ασφαλής περιοχή	Όχι	<ul style="list-style-type: none"> Εκτός της ζώνης 2 Τυπικές εφαρμογές αποκεντρωμένης περιφέρειας

Στη συνέχεια θα βρείτε σημαντικές υποδείξεις για την εγκατάσταση της αποκεντρωμένης περιφερειακής συσκευής ET 200M και του δομικού συγκροτήματος SIMATIC S7-300 σε επικίνδυνη για έκρηξη περιοχή.

Επιπλέον πληροφορίες

Επιπλέον πληροφορίες για τη συσκευή ET 200M και για τα διάφορα δομικά συγκροτήματα (ενότητες) S7-300 θα βρείτε στο εγχειρίδιο.

Τόπος κατασκευής

Siemens AG, Bereich A&D
Werner-von-Siemens-Straße 50
92224 Amberg
Germany

Άδεια

 II 3 G EEx nA II T3 .. T6 σύμφωνα με το πρότυπο
EN 50021 : 1999

Αριθμός ελέγχου: **KEMA 02ATEX1096 X**

Υπόδειξη

Τα δομικά συγκροτήματα με την άδεια  II 3 G EEx nA II T3 .. T6 επιτρέπεται να τοποθετηθούν μόνο σε συστήματα αυτοματισμού SIMATIC S7-300 / ET 200M της κατηγορίας συσκευής 3.

Συντήρηση

Για μια επισκευή πρέπει να σταλθεί το αντίστοιχο δομικό συγκρότημα στον τόπο κατασκευής. Μόνο εκεί επιτρέπεται να γίνει η επισκευή.

Ιδιαίτερες προϋποθέσεις

1. Η αποκεντρωμένη περιφερειακή συσκευή ET 200M και το δομικό συγκρότημα SIMATIC S7-300 πρέπει να ενσωματωθούν σε ένα ερμάριο ζεύξης ή σε ένα μεταλλικό περίβλημα. Αυτά πρέπει να εξασφαλίζουν το λιγότερο το βαθμό προστασίας IP 54. Σε αυτήν την περίπτωση πρέπει να ληφθούν υπόψη οι περιβαλλοντικές συνθήκες, στις οποίες θα εγκατασταθεί η συσκευή. Για το περίβλημα πρέπει να προβλέπεται δήλωση του κατασκευαστή για τη ζώνη 2 (σύμφωνα με το πρότυπο EN 50021).
2. Εάν στο καλώδιο ή στην είσοδο του καλωδίου αυτού του περιβλήματος κάτω από συνθήκες λειτουργίας η θερμοκρασία ξεπεράσει τους 70 °C ή όταν κάτω από συνθήκες λειτουργίας η θερμοκρασία στη διακλάδωση του σύρματος μπορεί να είναι μεγαλύτερη από 80 °C, πρέπει οι θερμοκρασιακές ιδιότητες των καλωδίων να ταυτίζονται με τις πραγματικά μετρημένες θερμοκρασίες.
3. Οι χρησιμοποιούμενες εισόδους καλωδίων πρέπει να συμμορφώνονται με το βαθμό προστασίας IP 54 στην ενότητα 7.2 (σύμφωνα με το πρότυπο EN 50021).
4. Όλες οι συσκευές, συμπεριλαμβανομένων διακοπών κ.α., που συνδέονται στις εισόδους και εξόδους δομικών συγκροτημάτων ασφαλών σημάτων, πρέπει να φέρουν εγκριμένη προστασία κατά έκρηξης τύπου EEx nA ή EEx nC.
5. Πρέπει να ληφθούν μέτρα, να μην μπορεί να γίνει υπέρβαση της ονομαστικής τάσης μέσω αιφνίδιας μεταβολής της τάσης πάνω από 40 %.
6. Περιοχή θερμοκρασίας περιβάλλοντος: 0° C έως 60° C
7. Πρέπει να τοποθετηθεί μέσα στο περίβλημα σε ευδιάκριτο σημείο μετά το άνοιγμα μία πινακίδα με την ακόλουθη προειδοποίηση:
 Προειδοποίηση
 Το περίβλημα επιτρέπεται να ανοίγει μόνο για μικρό χρονικό διάστημα, π.χ. για τη διενέργεια οπτικής διάγνωσης. Μην κάνετε χρήση διακοπών, μην τραβάτε ή εμβυσαμάωνετε δομικά συγκροτήματα και μη διαχωρίζετε ηλεκτροφόρους αγωγούς (εμβυσαματώσιμες συνδέσεις).
 Η προειδοποίηση αυτή δε χρειάζεται να ληφθεί υπ' όψιν, εάν είναι γνωστό ότι δεν υφίσταται ατμόσφαιρα παρουσιάζουσα κίνδυνο έκρηξης.

Κατάλογος των εγκεκριμένων δομικών συγκροτημάτων

Η λίστα με τα εγκεκριμένα δομικά συγκροτήματα υπάρχει στο διαδίκτυο:

<http://www4.ad.siemens.de/view/cs/>

με τον κωδικό συνδρομής 13702947

2

Power Supply Modules

Introduction

Various power supply modules are available to supply your S7-300 programmable controller and the sensors/actuators with 24 VDC.

Power supply modules

This chapter describes the technical specifications of the power supply modules of the S7-300 programmable controller.

In addition to the technical specifications, this chapter describes the following:

- The characteristics
- Connection diagram
- Block diagram
- Line protection
- Reaction to atypical operating conditions

In this chapter

Section	Contents	Page
2.1	Power Supply Module PS 305; 2 A; (6ES7 305-1BA80-0AA0)	2-2
2.2	Power Supply Module PS 307; 2 A; (6ES7 307-1BA00-0AA0)	2-6
2.3	Power Supply Module PS 307; 5 A; (6ES7 307-1EAx0-0AA0)	2-10
2.4	Power Supply Module PS 307; 10 A; (6ES7 307-1KA00-0AA0)	2-15

2.1 Power Supply Module PS 305; 2 A; (6ES7 305-1BA80-0AA0)

Order number "SIMATIC Outdoor module"

6ES7 305-1BA80-0AA0

Characteristics

The PS 305 power supply module (2 A) has the following salient features:

- Output current 2 A
- Output voltage 24 VDC; proof against short-circuit and open circuit
- Connection to DC power supply
(rated input voltage 24/48/72/96/110 VDC)
- Reliable isolation to EN 60 950
- Can be used as load power supply

Wiring schematic of the PS 305; 2 A

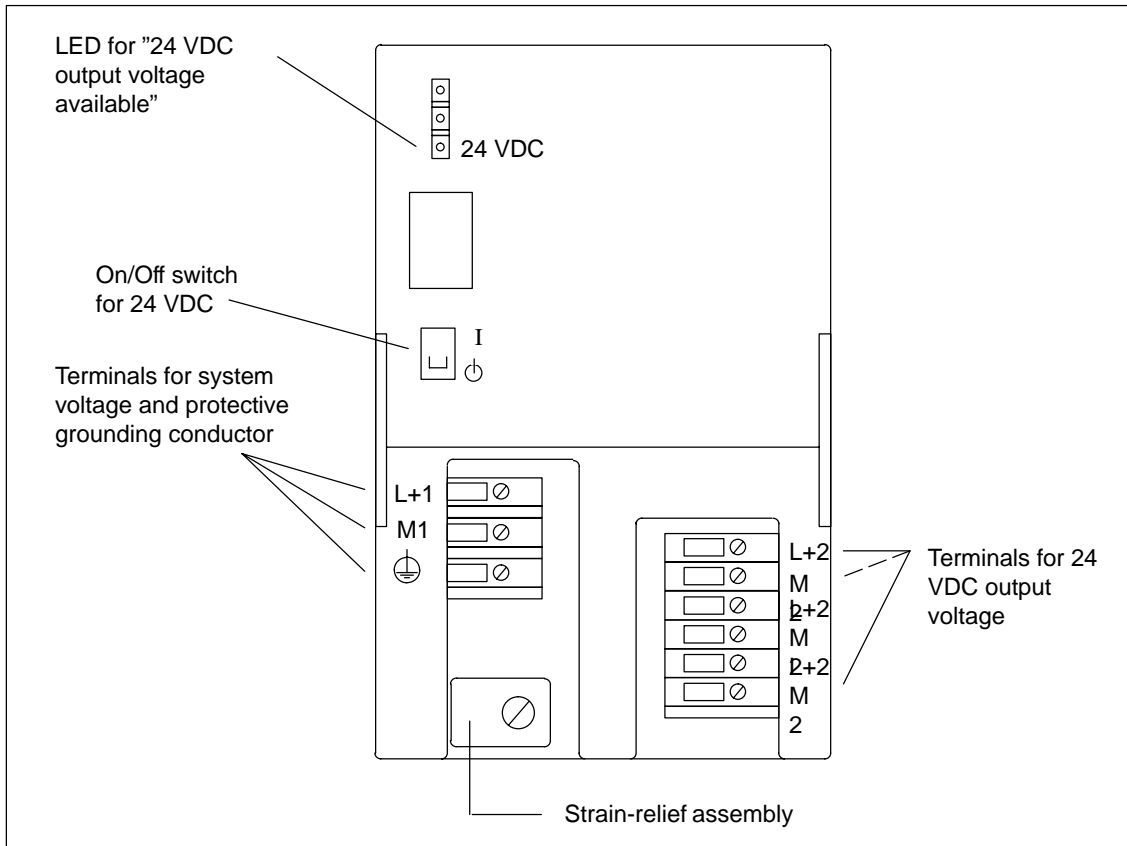

Figure 2-1 Wiring Schematic of the PS 305 Power Supply Module (2 A)

Technical specifications of the PS 305; 2 A (6ES7 305-1BA80-0AA0)

Dimensions and Weight		Other Parameters	
Dimensions W × H × D (in millimeters)	80 × 125 × 120	Protection class according to IEC 536 (DIN VDE 0106, Part 1)	I, with protective grounding conductor
Weight	Approx. 740 g	Insulation	
Input Rating		• Isolation voltage rating (24 V to input)	150 VAC
Input voltage		• Tested with	2800 VDC
• Rated value	24/48/72/96/110 VDC	Reliable isolation	SELV circuit
• Voltage range	16.8 to 138 VDC	Buffering of supply failures (at 24/48/72/96/110 V)	> 10 ms
Rated input current		• Repeat rate	min. 1 s
• At 24 V	2.7 A	Efficiency	75%
• At 48 V	1.3 A	Power input	64 W
• At 72 V	0.9 A	Power loss	16 W
• At 96 V	0.65 A	Diagnostics	
• At 110 V	0.6 A	LED for output voltage available	Yes, green LED
Inrush current (at 25 °C)	20 A		
I ² t (at inrush current)	5 A ² s		
Output Rating			
Output voltage			
• Rated value	24 VDC		
• Permitted range	24 V ± 3 %, stable at no load		
• Ramp-up time	max. 3 s		
Output current			
• Rated value	2 A; ¹⁾ Can be connected in parallel		
Short-circuit protection	Electronic, nonlatching, from 1.65 to 1.95 × I _N		
Residual ripple	max. 150 mV _{SS}		

¹⁾ With limited input voltage range > 24 V (24 to 138 VDC) the PS 305 can be loaded with 3 A.

Basic circuit diagram of the PS 305; 2 A

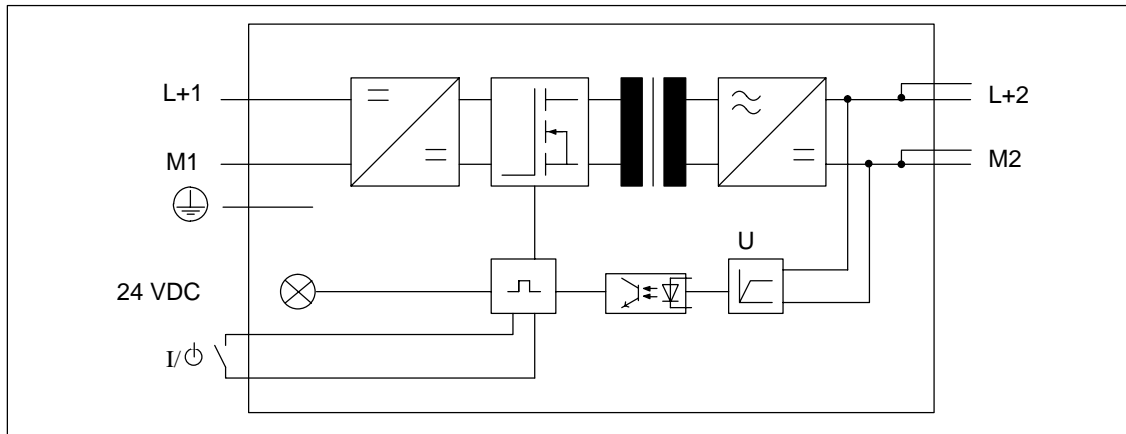

Figure 2-2 Basic Circuit Diagram of the PS 305 Power Supply Module (2 A)

Line protection

We recommend that you install a miniature circuit-breaker (MCB) (for example Siemens 5SN1 series) with the following rating to protect the incoming supply cable of the PS 305 power supply module (2 A):

- Rated current at 110 VDC: 10 A
- Tripping characteristic (type): C.

Reaction to atypical operating conditions

Table 2-1 Reaction of the PS 305 Power Supply Module (2 A) to Atypical Operating Conditions

If Then ...	24 VDC LED
... the output circuit is overloaded: <ul style="list-style-type: none"> • $I > 3.9 \text{ A}$ (dynamic) • $3 \text{ A} < I \leq 3.9 \text{ A}$ (static) 	Voltage dip, autom. volt. recovery Voltage drop, shortening of service life	Flashes
... the output is short-circuited	Output voltage 0 V; automatic voltage recovery after short circuit has been eliminated	Dark
An overvoltage occurs on the primary side	Possible destruction	-
There is an undervoltage on the primary side	Automatic disconnection; automatic voltage recovery	Dark

2.2 Power Supply Module PS 307; 2 A; (6ES7 307-1BA00-0AA0)

Order number

6ES7 307-1BA00-0AA0

Characteristics

The PS 307 power supply module (2 A) has the following salient features:

- Output current 2 A
- Output voltage 24 VDC; proof against short-circuit and open circuit
- Connection to single-phase AC system
(input voltage 120/230 VAC, 50/60 Hz)
- Reliable isolation to EN 60 950
- Can be used as load power supply

Wiring schematic of the PS 307; 2 A

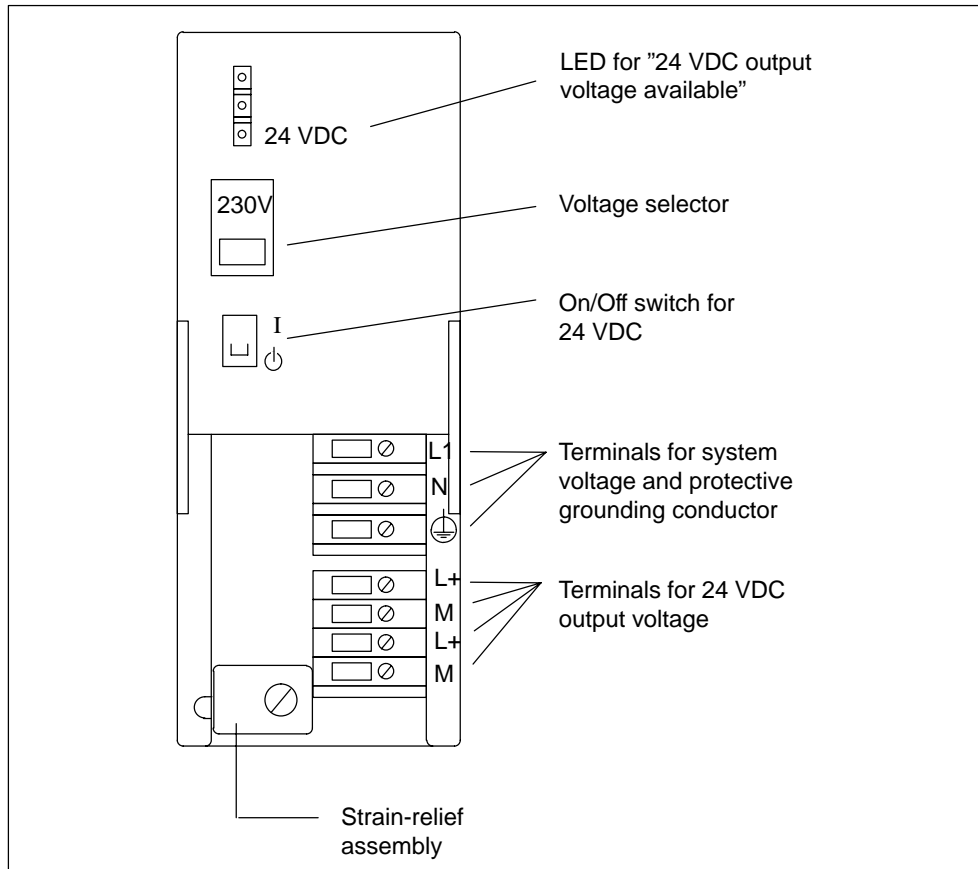

Figure 2-3 Wiring Schematic of the PS 307 Power Supply Module (2 A)

Basic circuit diagram of the PS 307; 2 A

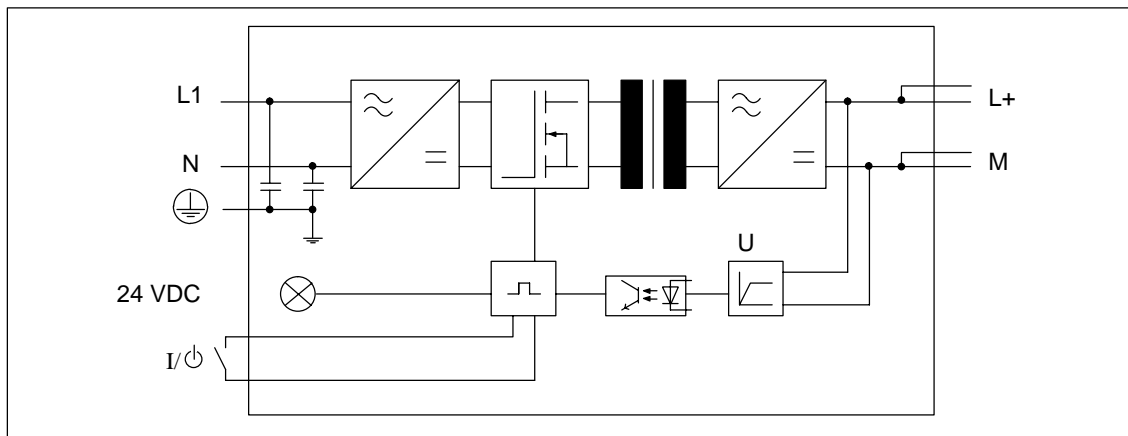

Figure 2-4 Basic Circuit Diagram of the PS 307 Power Supply Module (2 A)

Line protection

We recommend that you install a miniature circuit-breaker (MCB) (for example Siemens 5SN1 series) with the following rating to protect the incoming supply cable of the PS 307 power supply module (2 A):

- Rated current at 230 VAC: 6 A
- Tripping characteristic (type): C.

Reaction to atypical operating conditions

Table 2-2 Reaction of the PS 307 Power Supply Module (2 A) to Atypical Operating Conditions

If Then ...	24 VDC LED
... the output circuit is overloaded: <ul style="list-style-type: none"> • $I > 2.6 \text{ A}$ (dynamic) • $2 \text{ A} < I \leq 2.6 \text{ A}$ (static) 	Voltage dip, autom. volt. recovery Voltage drop, shortening of service life	Flashes
... the output is short-circuited	Output voltage 0 V; automatic voltage recovery after short circuit has been eliminated	Dark
An overvoltage occurs on the primary side	Possible destruction	-
There is an undervoltage on the primary side	Automatic disconnection; automatic voltage recovery	Dark

Technical specifications of the PS 307; 2 A (6ES7 307-1BA00-0AA0)

Dimensions and Weight		Other Parameters	
Dimensions W × H × D (in millimeters)	50 × 125 × 120	Protection class according to IEC 536 (DIN VDE 0106, Part 1)	I, with protective grounding conductor
Weight	Approx. 420 g	Insulation	
Input Rating		• Rated insulation level (24 V to L1)	250 VAC
Input voltage		• Tested with	2800 VDC
• Rated value	120 / 230 VAC	Reliable isolation	SELV circuit
System frequency		Bridging of power failures (at 93 and/or 187 V)	min. 20 ms
• Rated value	50 Hz or 60 Hz	• Repeat rate	min 1 s
• Permitted range	47 Hz to 63 Hz	Efficiency	83 %
Rated input current		Power input	58 W
• At 230 V	0.5 A	Power loss	typ. 10 W
• At 120 V	0.8 A	Diagnostics	
Inrush current (at 25°C)	20 A	LED for output voltage available	Yes, green LED
I ² t (at inrush current)	1 A ² s	Output Rating	
Output voltage		• Rated value	24 VDC
• Rated value	24 VDC	• Permitted range	24 V ± 5 %, stable at no load
• Permitted range	24 V ± 5 %, stable at no load	• Ramp-up time	max. 2.5 s
• Ramp-up time	max. 2.5 s	Output current	
Output current		• Rated value	2 A, Cannot be connected in parallel
• Rated value	2 A, Cannot be connected in parallel	Short-circuit protection	Electronic, nonlatching, 1.1 to 1.3 × I _N
Short-circuit protection	Electronic, nonlatching, 1.1 to 1.3 × I _N	Residual ripple	max. 150 mV _{SS}
Residual ripple	max. 150 mV _{SS}		

2.3 Power Supply Module PS 307; 5 A; (6ES7 307-1EAx0-0AA0)

Order number: "Standard module"

6ES7 307-1EA00-0AA0

Order number "SIMATIC Outdoor module"

6ES7 307-1EA80-0AA0

Characteristics

The PS 307 power supply module (5 A) has the following salient features:

- Output current 5 A
- Output voltage 24 VDC; proof against short-circuit and open circuit
- Connection to single-phase AC system
(input voltage 120/230 VAC, 50/60 Hz)
- Reliable isolation to EN 60 950
- Can be used as load power supply

Wiring schematic of the PS 307; 5 A

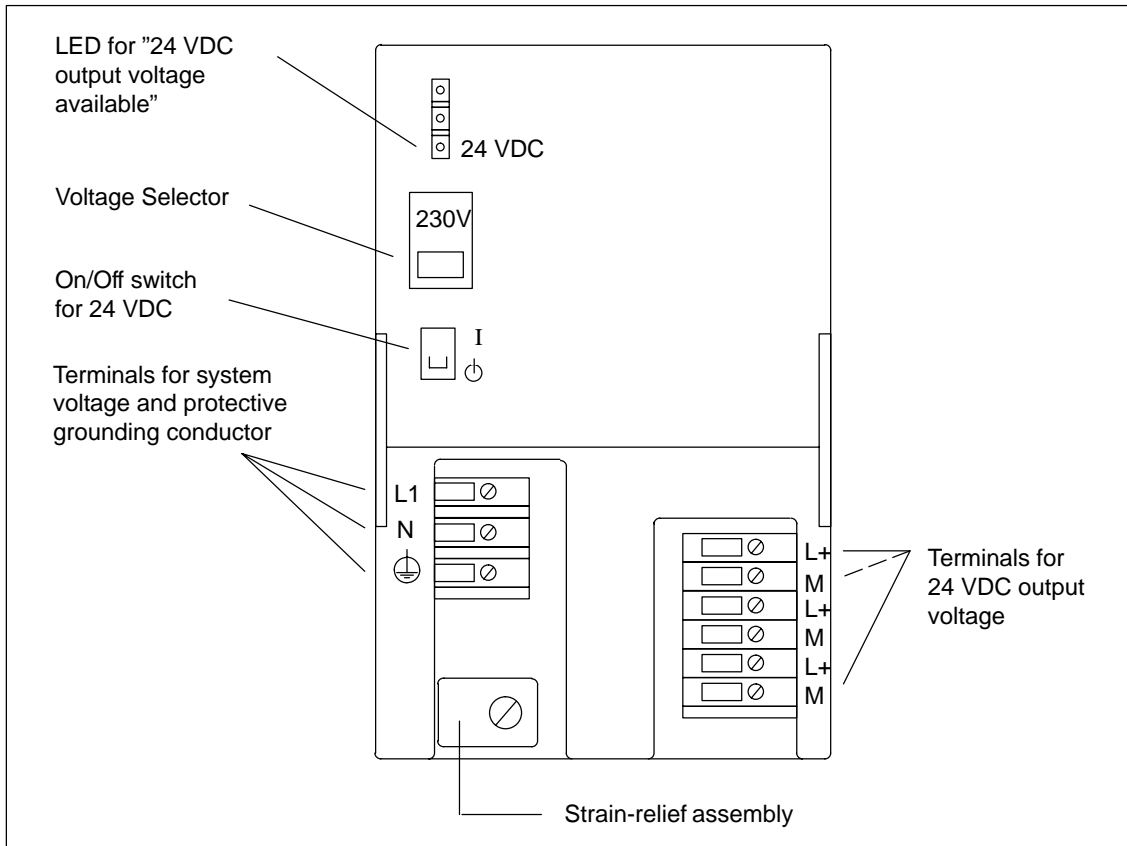

Figure 2-5 Wiring Schematic of the PS 307 Power Supply Module (5 A)

Basic circuit diagram of the PS 307; 5 A

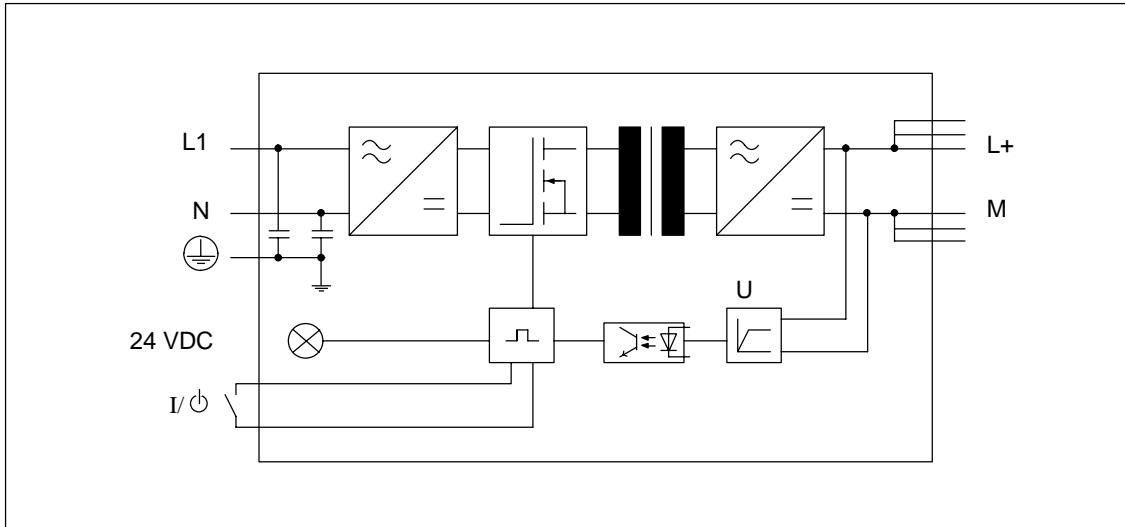

Figure 2-6 Basic Circuit Diagram of the PS 307 Power Supply Module (5 A)

Line protection

We recommend that you install a miniature circuit-breaker (MCB) (for example Siemens 5SN1 series) with the following rating to protect the incoming supply cable of the PS 307 power supply module (5 A):

- Rated current at 230 VAC: 10 A
- Tripping characteristic (type): C.

Reaction to atypical operating conditions

Table 2-3 Reaction of the PS 307 Power Supply Module (5 A) to Atypical Operating Conditions

If Then ...	24 VDC LED
... the output circuit is overloaded: <ul style="list-style-type: none"> • $I > 6.5 \text{ A}$ (dynamic) • $5 \text{ A} < I \leq 6.5 \text{ A}$ (static) 	Voltage dip, autom. volt. recovery Voltage drop, shortening of service life	Flashes
... the output is short-circuited	Output voltage 0 V; automatic voltage recovery after short circuit has been eliminated	Dark
An overvoltage occurs on the primary side	Possible destruction	–
There is an undervoltage on the primary side	Automatic disconnection; automatic voltage recovery	Dark

Technical specifications of the PS 307; 5 A (6ES7 307-1EA00-0AA0)

Dimensions and Weight		Other Parameters	
Dimensions W × H × D (in millimeters)	80 × 125 × 120	Protection class according to IEC 536 (DIN VDE 0106, Part 1)	I, with protective grounding conductor
Weight	Approx. 740 g	Insulation	
Input Rating		• Rated insulation level (24 V to L1)	250 VAC
Input voltage		• Tested with	2800 VDC
• Rated value	120 / 230 VAC	Reliable isolation	SELV circuit
System frequency		Bridging of power failures (at 93 and/or 187 V)	min. 20 ms
• Rated value	50 Hz or 60 Hz	• Repeat rate	min 1 s
• Permitted range	47 Hz to 63 Hz	Efficiency	87 %
Rated input current		Power input	138 W
• At 120 V	2 A	Power loss	typ. 18 W
• At 230 V	1 A	Diagnostics	
Inrush current (at 25 °C)	45 A	LED for output voltage available	Yes, green LED
I ² t (at inrush current)	1.2 A ² s	Output Rating	
Output voltage		• Rated value	24 VDC
• Rated value	24 VDC	• Permitted range	24 V ± 5 %, stable at no load
• Permitted range	24 V ± 5 %, stable at no load	• Ramp-up time	max. 2.5 s
• Ramp-up time	max. 2.5 s	Output current	
Output current		• Rated value	5 A
• Rated value	5 A	Cannot be connected in parallel	
Short-circuit protection	Electronic, nonlatching, from 1.1 to 1.3 × I _N	Residual ripple	max. 150 mV _{SS}

Technical specifications of the PS 307; 5 A (6ES7 307-1EA80-0AA0)

Dimensions and Weight		Other Parameters	
Dimensions W × H × H (in millimeters)	80 × 125 × 120	Protection class according to IEC 536 (DIN VDE 0106, Part 1)	I, with protective grounding conductor
Weight	Approx. 570 g	Insulation	
Input Rating		• Rated insulation level (24 V to L1)	250 VAC
Input voltage		• Tested with	2800 VDC
• Rated value	120/230 VDC	Reliable isolation	SELV circuit
System frequency		Bridging of power failures (at 93 and/or 187 V)	min. 20 ms
• Rated value	50 Hz or 60 Hz	• Repeat rate	min. 1 s
• Permitted range	47 Hz to 63 Hz	Efficiency	84%
Rated input current		Power input	143 W
• At 120 V	2.1 A	Power loss	23 W
• At 230 V	1.2 A	Diagnostics	
Inrush current (at 25 °C)	45 A	LED for output voltage available	Yes, green LED
I ² t (at inrush current)	1.8 A ² s	Output Rating	
Output voltage		• Rated value	24 VDC
• Rated value	24 VDC	• Permitted range	24 V ± 3 %
• Permitted range	24 V ± 3 %	• Ramp-up time	max. 3 s
• Ramp-up time	max. 3 s	Output current	
Output current		• Rated value	5 A; cannot be connected in parallel
• Rated value	5 A; cannot be connected in parallel	Short-circuit protection	Electronic, nonlatching, from 1.1 to 1.3 × I _N
Short-circuit protection	Electronic, nonlatching, from 1.1 to 1.3 × I _N	Residual ripple	max. 150 mV _{SS}
Residual ripple	max. 150 mV _{SS}		

2.4 Power Supply Module PS 307; 10 A; (6ES7 307-1KA00-0AA0)

Order number

6ES7 307-1KA00-0AA0

Characteristics

The PS 307 power supply module (10 A) has the following salient features:

- Output current 10 A
- Output voltage 24 VDC; proof against short-circuit and open circuit
- Connection to single-phase AC system
(input voltage 120/230 VAC, 50/60 Hz)
- Reliable isolation to EN 60 950
- Can be used as load power supply

Wiring schematic of the PS 307; 10 A

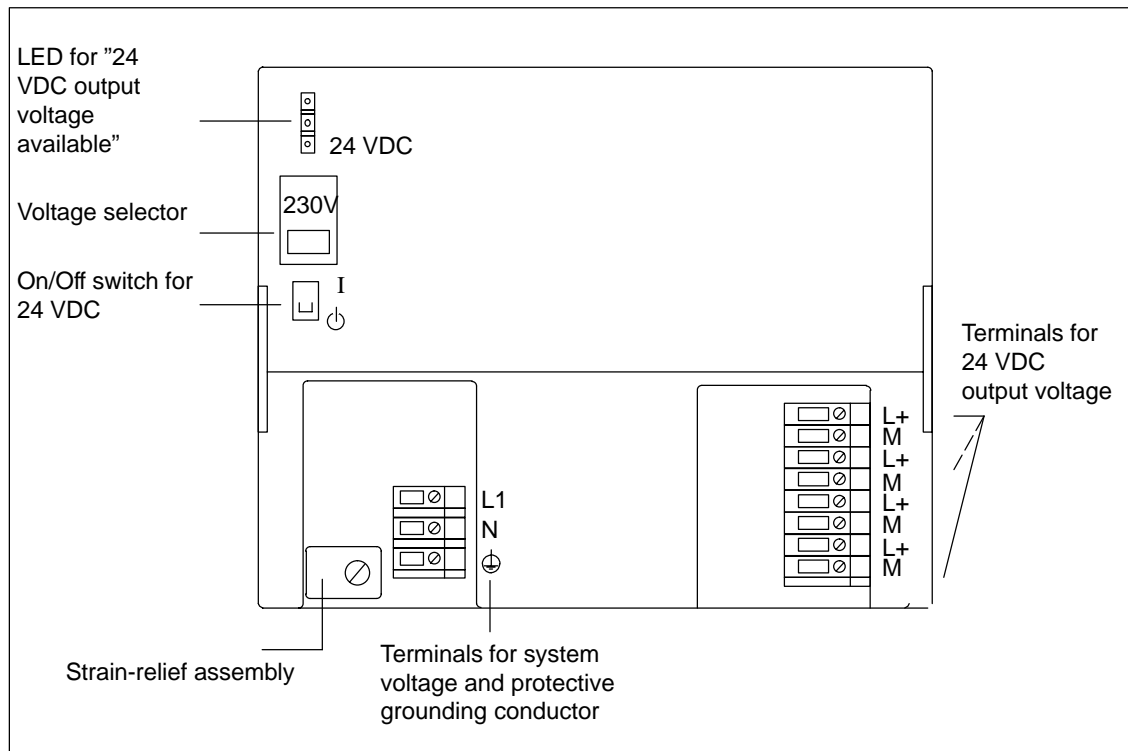

Figure 2-7 Wiring Schematic of the PS 307 Power Supply Module (10 A)

Basic circuit diagram of the PS 307; 10 A

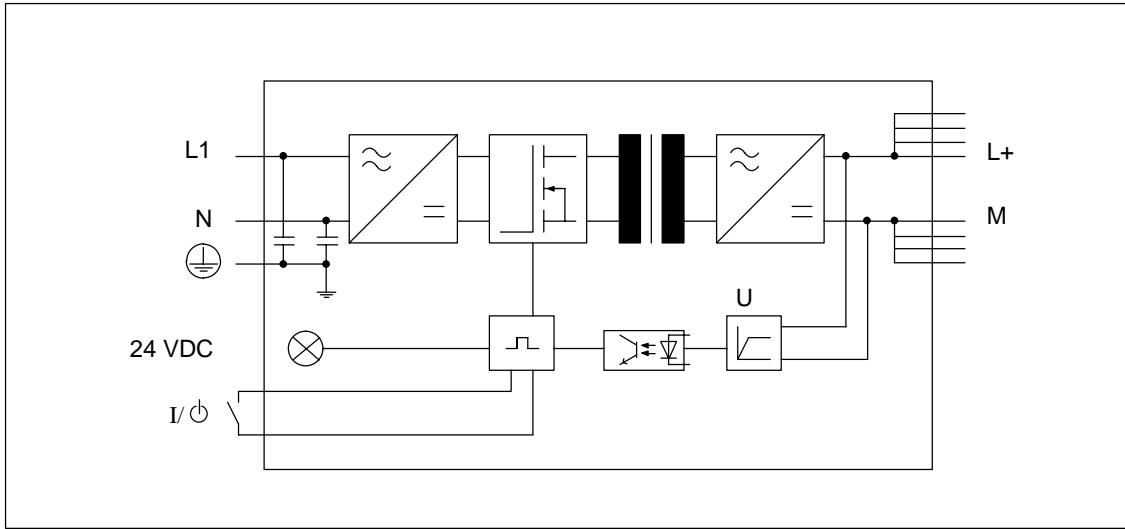

Figure 2-8 Basic Circuit Diagram of the PS 307 Power Supply Module (10 A)

Line protection

We recommend that you install a miniature circuit-breaker (MCB) (for example, Siemens 5SN1 series) with the following rating to protect the incoming supply cable of the PS 307 power supply module (10 A):

- Rated current at 230 VAC: 16 A
- Tripping characteristic (type): C.

Reaction to atypical operating conditions

Table 2-4 Reaction of the PS 307 Power Supply Module (10 A) to Atypical Operating Conditions

If ...	Reaction of the Module	24 VDC LED
... the output circuit is overloaded: <ul style="list-style-type: none"> • $I > 13 \text{ A}$ (dynamic) • $10 \text{ A} < I \leq 13 \text{ A}$ (static) 	Voltage dip, autom. volt. recovery Voltage drop, shortening of service life	Flashes
... the output is short-circuited	Output voltage 0 V; automatic voltage recovery after short circuit has been eliminated	Dark
An overvoltage occurs on the primary side	Possible destruction	–
There is an undervoltage on the primary side	Automatic disconnection; automatic voltage recovery	Dark

Technical specifications of the PS 307; 10 A (6ES7 307-1KA00-0AA0)

Dimensions and Weight		Other Parameters	
Dimensions W × H × D (in millimeters)	200 × 125 × 120	Protection class according to IEC 536 (DIN VDE 0106, Part 1)	I, with protective grounding conductor
Weight	1.2 kg	Insulation	
Input Rating		• Rated insulation level (24 V to L1)	250 VAC
Input voltage		• Tested with	2800 VDC
• Rated value	120 / 230 VAC	Reliable isolation	SELV circuit
System frequency		Bridging of power failures (at 93 and/or 187 V)	min. 20 ms
• Rated value	50 Hz or 60 Hz	• Repeat rate	min 1 s
• Permitted range	47 Hz to 63 Hz	Efficiency	89 %
Rated input current		Power input	270 W
• At 230 V	1.7 A	Power loss	typ. 30 W
• At 120 V	3.5 A		
Inrush current (at 25 °C)	55 A		
I ² t (at inrush current)	9 A ² s		
Output Rating		Diagnostics	
Output voltage		LED for output voltage available	Yes, green LED
• Rated value	24 VDC		
• Permitted range	24 V ± 5 %, stable at no load		
• Ramp-up time	max. 2.5 s		
Output current			
• Rated value	10 A, Cannot be connected in parallel		
Short-circuit protection	Electronic, nonlatching, 1.1 to 1.3 × I _N		
Residual ripple	max. 150 mV _{SS}		

Digital Modules

Changes and improvements compared to the previous edition of the Reference Manual

This chapter describes all new digital modules. Furthermore, two new overview sections will make it easier for you to access the information:

- The "Module Overview" section shows you the modules that are available, together with their most important characteristics, and helps you quickly to find the module suitable for your task.
- The section entitled "Sequence of Steps from Choosing to Commissioning the Module" provides the answer to the question "What must I do in succession to commission the module quickly and successfully?"

Structure of the chapter

The present chapter is broken down into the following subjects:

1. Overview containing the modules that are available here and a description
2. Information that is generally valid – in other words, relating to all digital modules (for example, parameter assignment and diagnostics)
3. Information that refers to specific modules (for example, characteristics, diagram of connections and block diagram, technical specifications and special characteristics of the module):
 - a) for digital input modules
 - b) for digital output modules
 - c) for relay output modules
 - d) for digital input/output modules

Additional information

Appendix A describes the structure of the parameter sets (data records 0, 1 and 128) in the system data. You must be familiar with this configuration if you want to modify the parameters of the modules in the *STEP 7* user program.

Appendix B describes the structure of the diagnostic data (data records 0 and 1) in the system data. You must be familiar with this configuration if you want to evaluate the diagnostic data of the modules in the *STEP 7* user program.

In this chapter

Section	Contents	Page
3.1	Module Overview	3-4
3.2	Sequence of Steps from Choosing to Commissioning the Digital Module	3-10
3.3	Assigning Parameters to Digital Modules	3-11
3.4	Diagnostics of Digital Modules	3-12
3.5	Digital Input Module SM 321; DI 32 × 24 VDC; (6ES7 321-1BLx0-0AA0)	3-13
3.6	Digital Input Module SM 321; DI 32 × 120 VAC; (6ES7 321-1EL00-0AA0)	3-16
3.7	Digital Input Module SM 321; DI 16 × 24 VDC; (6ES7 321-1BHx2-0AA0)	3-18
3.8	Digital Input Module SM 321; DI 16 × 24 VDC High Speed; (6ES7 321-1BH10-0AA0)	3-21
3.9	Digital Input Module SM 321; DI 16 × 24 VDC; with Hardware and Diagnostic Interrupts, Clocked; (6ES7 321-7BHx0-0AB0)	3-23
3.10	Digital Input Module SM 321; DI 16 × 24 VDC; Source Input; (6ES7 321-1BH50-0AA0)	3-33
3.11	Digital Input Module SM 321; DI 16 × UC 24/48 V ; (6ES7 321-1CH00-0AA0)	3-35
3.12	Digital Input Module SM 321; DI 16 × 48-125 VDC; (6ES7 321-1CH80-0AA0)	3-37
3.13	Digital Input Module SM 321; DI 16 × 120/230 VAC; (6ES7 321-1FH00-0AA0)	3-39
3.14	Digital Input Module SM 321; DI 8 × 120/230 VAC; (6ES7 321-1FFx1-0AA0)	3-41
3.15	Digital Input Module SM 321; DI 8 × 120/230 VAC ISOL (6ES7 321-1FF10-0AA0)	3-43
3.16	Digital Input Module SM 322; DO 32 × 24 VDC/0.5 A; (6ES7 322-1BL00-0AA0)	3-45
3.17	Digital Output Module SM 322; DO 32 × 120 VAC/1.0 A; (6ES7 322-1EL00-0AA0)	3-48
3.18	Digital Output Module SM 322; DO 16 × 24 VDC/0.5 A; (6ES7 322-1BHx1-0AA0)	3-52
3.19	Digital Output Module SM 322; DO 16 × 24 VDC/0.5 A High Speed; (6ES7 322-1BH10-0AA0)	3-55
3.20	Digital Output Module SM 322; DO 16 × 24/48 VUC (6ES7 322-5GH00-0AB0)	3-58
3.21	Digital Output Module SM 322; DO 16 × 120/230 VAC/1 A (6ES7 322-1FH00-0AA0)	3-64
3.22	Digital Output Module SM 322; DO 8 × 24 VDC/2 A; (6ES7 322-1BF01-0AA0)	3-67

Section	Contents	Page
3.23	Digital Output Module SM 322; DO 8 × 24 VDC/0.5 A; with Diagnostic Interrupt; (6ES7 322-8BFx0-0AB0)	3-70
3.24	Digital Output Module SM 322; DO 8 × 48-125 VDC/1.5 A; (6ES7 322-1CF80-0AA0)	3-80
3.25	Digital Output Module SM 322; DO 8 × 120/230 VAC/2 A; (6ES7 322-1FFx1-0AA0)	3-83
3.26	Digital Output Module SM 322; DO 8 × 120/230 VAC/2 A ISOL (6ES7 322-5FF00-0AB0)	3-86
3.27	Relay Output Module SM 322; DO 16 × Rel. 120/230 VAC; (6ES7 322-1HH01-0AA0)	3-92
3.28	Relay Output Module SM 322; DO 8 × Rel. 230 VAC; (6ES7 322-1HF01-0AA0)	3-95
3.29	Relay Output Module SM 322; DO 8 × Rel. 230 VAC/5A; (6ES7 322-5HF00-0AB0)	3-98
3.30	Relay Output Module SM 322; DO 8 × Rel. 230 VAC/5 A; (6ES7 322-1HFx0-0AA0)	3-105
3.31	Digital Input/Output Module SM 323; DI 16/DO16 × 24 VDC/0.5 A; (6ES7 323-1BL00-0AA0)	3-110
3.32	Digital Input/Output Module SM 323; DI 8/DO 8 × 24 VDC/0.5 A; (6ES7 323-1BHx1-0AA0)	3-114

3.1 Module Overview

Introduction

The following tables summarize the most important characteristics of the digital modules. This overview is intended to make it easy to choose the suitable module for your task.

Table 3-1 Digital Input Modules: Characteristics at a Glance

Module Characteristics	SM 321; DI 32 × 24 VDC (-1BLx0-)	SM 321; DI 32 × 120 VAC (-1EL00-)	SM 321; DI 16 × 24 VDC (-1BHx2-)	SM 321; DI 16 × 24 VDC High Speed (-1BH10-)	SM 321; DI 16 × 24 VDC with hardware and diagnostic interrupts (-7BHx0-)	SM 321; DI 16 × 24 VDC; source input (-1BH50-)
Number of inputs	32 DI; isolated in groups of 16	32 DI; isolated in groups of 8	16 DI; isolated in groups of 16	16 DI; isolated in groups of 16	16 DI; isolated in groups of 16	16 DI, source input, isolated in groups of 16
Rated input voltage	24 VDC	120 VAC	24 VDC	24 VDC	24 VDC	24 VDC
Suitable for...	Switches; two, three, and four-wire proximity switches (BEROs)					
Supports clocked operation	No	No	No	Yes	No	No
Programmable diagnostics	No	No	No	No	Yes	No
Diagnostic interrupt	No	No	No	No	Yes	No
Hardware interrupt upon edge change	No	No	No	No	Yes	No
Settable input delays	No	No	No	No	Yes	No
Special features	–	–	–	–	2 short-circuit- proof sensor supplies for 8 channels each External redundant power supply possible to supply sensors	–

Table 3-2 Digital Input Modules: Characteristics at a Glance (continued)

Module Charac- teristics	SM 321; DI 16×UC 24/48V (-1CH00-)	SM 321; DI 16×48-125 VDC (-1CH80-)	SM 321; DI 16×120/230 VAC (-1FH00-)	SM 321; DI 8×120/230 VAC (-1FFx1-)	SM 321; DI 8×120/230 VAC ISOL (-1FF10-)
Number of inputs	16 DI; isolated in groups of 1	16 DI; isolated in groups of 8	16 DI; isolated in groups of 4	8 DI, isolated in groups of 2	8 DI; isolated in groups of 1
Rated input voltage	24 to 48 VDC, 24 to 48 VAC	48 to 125 VDC	120/230 VAC	120/230 VAC	120/230 VAC
Suitable for...	Switches; two, three, and four-wire proximity switches (BEROs)		Switches; two and three-wire AC proximity switches		
Supports clocked operation	No	No	No	No	No
Programmable diagnostics	No	No	No	No	No
Diagnostic Interrupt	No	No	No	No	No
Hardware interrupt upon edge change	No	No	No	No	No
Settable input delays	No	No	No	No	No
Special features		–		–	

Table 3-3 Digital Output Modules: Characteristics at a Glance

Module Characteristics	SM 322; DO 32 × 24 VDC 0.5 A (-1BL00-)	SM 322; DO 32 × × 120VAC/ 1.0 A (-1EL00-)	SM 322; DO 16 × 24 VDC/ 0.5 A (-1BHx1-)	SM 322; DO 16 × 24 VDC/ 0.5 A High Speed (-1BH10-)	SM 322; DO 16 × 24/48 VUC (-5GH00-)	SM 322; DO 16 × 120/230 VDC/ 1 A (-1FH00-)
Number of outputs	32 DO; isolated in groups of 8	32 DO; isolated in groups of 8	16 DO; isolated in groups of 8	16 DO; isolated in groups of 8	16 DO; isolated in groups of 1	16 DO; isolated in groups of 8
Output current	0.5 A	1.0 A	0.5 A	0.5 A	0.5 A	0.5 A
Rated load voltage	24 VDC	120 VAC	24 VDC	24 VDC	24 to 48 VDC, 24 to 48 VAC	120/230 VAC
Suitable for...	Solenoid valves, DC contactors and indicator lights					
Supports clocked operation	No	No	No	Yes	No	No
Programmable diagnostics	No	No	No	No	Yes	No
Diagnostic Interrupt	No	No	No	No	Yes	No
Substitute value output	No	No	No	No	Yes	No
Special features	-					

Table 3-4 Digital Output Modules: Characteristics at a Glance (continued)

Module Characteristics	SM 322; DO 8 × 24 VDC/ 2 A (-1BF01-)	SM 322; DO 8 × 24 VDC/ 0.5 A with diagnostic interrupt (-8BFx0-)	SM 322; DO 8 × 48-125 VDC/ 1.5 A (-1CF80-)	SM 322; DO 8 × 120/ 230 VAC/2A (-1FFx1-)	SM 322; DO 8 × 120/ 230 VAC/ 2A ISOL (-5FF00-)
Number of outputs	8 DO; isolated in groups of 4	8 DO; isolated in groups of 8	8 DO; isolated and reverse polarity protection, in groups of 4	8 DO; isolated in groups of 4	8 DO; isolated in groups of 1
Output current	2 A	0.5 A	1.5 A	2 A	2 A
Rated load voltage	24 VDC	24 VDC	48 to 125 VDC	120/230 VAC	120/230 VAC
Suitable for...	Solenoid valves, DC contactors and indicator lights			AC solenoid valves, contactors, motor starters, fractional h.p. motors and indicator lights.	
Supports clocked operation	No	No	No	No	No
Programmable diagnostics	No	Yes	No	No	Yes
Diagnostic Interrupt	No	Yes	No	No	Yes
Substitute value output	No	Yes	No	No	Yes
Special features	–	Redundant driving of a load possible	–	Fuse blown display. Replaceable fuse for each group	-

Table 3-5 Relay Output Modules: Characteristics at a Glance

Module Charac- teristics	SM 322; DO 16 × Rel. 120 VAC (-1HH01-)	SM 322; DO 8 × Rel. 230 VAC (-1HF01-)	SM 322; DO 8 × Rel. 230 VAC/ 5 A (-5HF00-)	SM 322; DO 8 × Rel. 230 VAC/ 5 A (-1HFx0-)
Number of outputs	16 outputs, isolated in groups of 8	8 outputs, isolated in groups of 2	8 outputs, isolated in groups of 1	8 outputs, isolated in groups of 1
Rated load voltage	24 to 120 VDC, 48 to 230 VAC	24 to 120 VDC, 48 to 230 VAC	24 to 120 VDC, 24 to 230 VAC	24 to 120 VDC, 48 to 230 VAC
Suitable for...	AC/DC solenoid valves, contactors, motor starters, fractional horsepower motors and indicator lights			
Supports clocked operation	No	No	No	No
Programmable diagnostics	No	No	Yes	No
Diagnostic Interrupt	No	No	Yes	No
Substitute value output	No	No	Yes	No
Special features	—			

Table 3-6 Digital Input/Output Modules: Characteristics at a Glance

Module Characteristics	SM 323; DI 16/DO 16 × 24 VDC/ 0.5 A (-1BL00-)	SM 323; DI 8/DO 8 × 24 VDC/0.5 A (-1BHx1-)
Number of inputs	16 inputs, isolated in groups of 16	8 inputs, isolated in groups of 8
Number of outputs	16 outputs, isolated in groups of 8	8 outputs, isolated in groups of 8
Rated input voltage	24 VDC	24 VDC
Output current	0.5 A	0.5 A
Rated load voltage	24 VDC	24 VDC
Inputs suitable for...	Switches and two, three and four-wire proximity switches (BEROs).	
Outputs suitable for...	Solenoid valves, DC contactors and indicator lights	
Supports clocked operation	No	No
Programmable diagnostics	No	No
Diagnostic Interrupt	No	No
Hardware interrupt upon edge change	No	No
Settable input delay	No	No
Substitute value output	No	No
Special Features	–	

3.2 Sequence of Steps from Choosing to Commissioning the Digital Module

Introduction

The following table contains the tasks that you have to perform one after the other to commission digital modules successfully.

The sequence of steps is a suggestion, but you can perform individual steps either earlier or later (for example, assign parameters to the module) or install other modules or install, commission etc. other modules in between times.

Sequence of steps

Table 3-7 Sequence of Steps from Choosing to Commissioning the Digital Module

Step	Procedure	Refer to...
1.	Select the module	Section 3.1 and specific module section from Section 3.5
2.	Install the module in the SIMATIC S7 network	"Mounting" section in the Installation Manual for the programmable logic controller being used: <ul style="list-style-type: none"> S7-300 Programmable Controllers, Hardware and Installation or S7-400, M7-400 Programmable Controllers, Hardware and Installation or ET 200M Distributed I/O Device
3.	Assign parameters to module	Section 3.3
4.	Commission configuration	"Commissioning" section in the Installation Manual for the programmable controller being used: <ul style="list-style-type: none"> S7-300 Programmable Controllers, Hardware and Installation or S7-400, M7-400 Programmable Controllers, Hardware and Installation or ET 200M Distributed I/O Device
5.	If commissioning was not successful, diagnose configuration	Section 3.4

3.3 Digital Module Parameter Assignment

Introduction

Digital modules can have different characteristics. You can set the characteristics of some modules by means of parameter assignment.

The information contained in this section refers only to the programmable digital modules:

- Digital input module SM 321; DI 16 × 24 VDC with hardware and diagnostic interrupts; (6ES7 321-7BHx0-0AB0)
- Digital output module SM 322; DO 8 × 24 VDC/0.5 A with diagnostic interrupt (6ES7 322-8BFx0-0AB0)
- Digital output module SM 322; DO 8 × 120/230 VAC /2A ISOL (6ES7 322-5FF00-0AB0)
- Relay output module SM 322; DO 8 × Rel. 230 VAC /5A (6ES7 322-5HF00-0AB0)

Tools for parameter assignment

You assign parameters to digital modules in *STEP 7*. You must perform parameter assignment in STOP mode of the CPU.

When you have set all the parameters, download the parameters from the programming device to the CPU. On a transition from STOP → to RUN mode, the CPU then transfers the parameters to the individual digital modules.

Static and dynamic parameters

The parameters are divided into static and dynamic parameters.

Set the static parameters in STOP mode of the CPU, as described above.

You can also change the dynamic parameters in the running user program in an S7 logic control using SFC. Note, however, that after a change from RUN → STOP, STOP → RUN of the CPU, the parameters set in *STEP 7* apply again. You will find a description of the parameter assignment of modules in the user program in Appendix A.

Parameter	Settable with	CPU Operating State
Static	PG (STEP7 HWCONFIG)	STOP
Dynamic	PG (STEP7 HWCONFIG)	STOP
	SFC 55 in the user program	RUN

Parameters of the digital modules

The settable parameters are listed in the special section on the module.

3.4 Diagnostics of the Digital Modules

Introduction

The information contained in this section refers only to the digital modules with diagnostics capability. For the S7-300, these modules are as follows:

- Digital input module SM 321; DI 16 × 24 VDC with hardware and diagnostic interrupts; (6ES7 321-7BHx0-0AB0)
- Digital output module SM 322; DO 8 × 24 VDC/0.5 A with diagnostic interrupt (6ES7 322-8BFx0-0AB0)
- Digital output module SM 322; DO 8 × 120/230 VAC /2A ISOL (6ES7 322-5FF00-0AB0)
- Relay output module SM 322; DO 8 × Rel. 230 VAC /5A (6ES7 322-5HF00-0AB0)

Programmable and non-programmable diagnostic messages

In diagnostics, we make a distinction between programmable and non-programmable diagnostic messages.

You obtain programmable diagnostic messages only if you have enabled diagnostics by parameter assignment. You perform parameter assignment in the "Diagnostics" parameter field in *STEP 7*.

Non-programmable diagnostic messages are always made available by the digital module irrespective of diagnostics being enabled.

Actions following diagnostic message in *STEP 7*

Each diagnostic message leads to the following actions:

- The diagnostic message is entered in the diagnosis of the digital module and forwarded to the CPU.
- The SF LED on the digital module lights.
- If you have programmed "Enable Diagnostic Interrupt" in *STEP 7*, a diagnostic interrupt is triggered and OB 82 is called.

Reading out diagnostic messages

You can read out detailed diagnostic messages by means of SFCs in the user program (refer to the Appendix "Diagnostic Data of Signal Modules").

You can view the cause of the error in *STEP 7*, in the module diagnosis (refer to online Help for *STEP 7*).

Diagnostic message by means of SF LED

The digital modules with diagnostics capability indicate errors for you by means of their SF LED (group error LED). The SF LED lights as soon as a diagnostic message is triggered by the digital module. It goes out when all errors have been rectified.

The group fault (SF) LED also lights up in case of external errors (short circuit of sensor supply), independent of the operating status of the CPU (if power is on).

Diagnostic messages interrupt processing by the digital modules

You will find the diagnostic messages with their possible causes and remedial action, together with a description of possible interrupts in the specific section on the module.

3.5 Digital Input Module SM 321; DI 32 × 24 VDC; (6ES7 321-1BLx0-0AA0)

Order number: "Standard module"

6ES7 321-1BL00-0AA0

Order number: "SIMATIC Outdoor module"

6ES7 321-1BL80-0AA0

Characteristics

The digital input module SM 321; DI 32 × 24 VDC has the following salient features:

- 32 inputs, isolated in groups of 16
- 24 VDC rated input voltage
- Suitable for switches and two / three / four-wire BEROs (proximity switches).

Terminal assignment and block diagram of the SM 321; DI 32 × 24 VDC

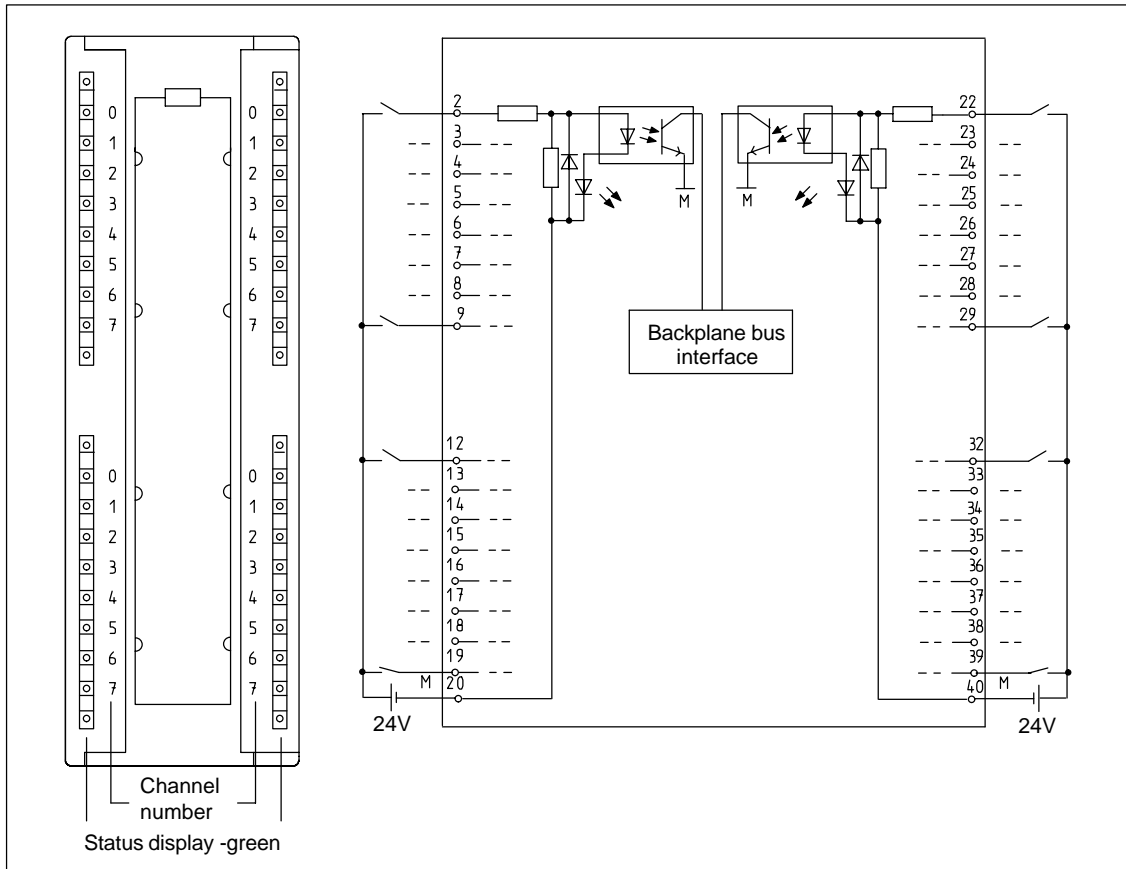

Figure 3-1 Module View and Block Diagram of the Digital Input Module SM 321; DI 32 × 24 VDC

Terminal assignment of the SM 321; DI 32 × 24 VDC

The following figure shows the assignment of the channels to the addresses.

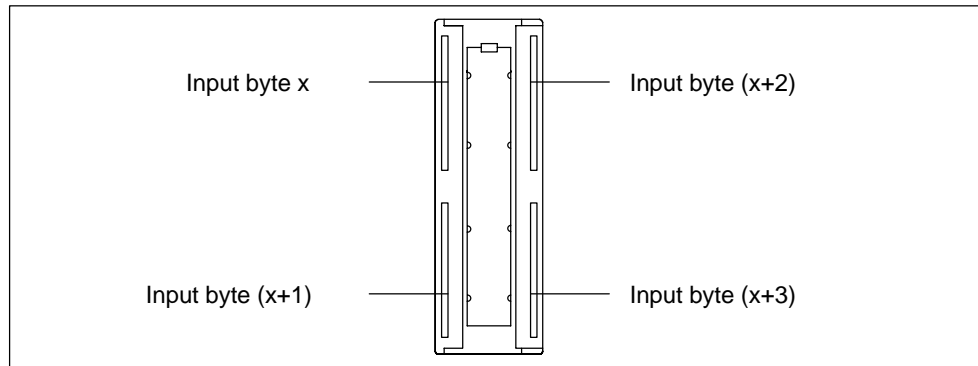

Figure 3-2 Terminal assignment of the SM 321; DI 32 × 24 VDC

Technical specifications of the SM 321; DI 32 × 24 VDC

Dimensions and Weight			
Dimensions W × H × D (in millimeters)	40 × 125 × 120	Insulation tested with	500 VDC
Weight	Approx. 260 g	Current consumption	
		• From the backplane bus	max. 15 mA
		Power dissipation of the module	typ. 6.5 W
Data for Specific Module		Status, Interrupts, Diagnostics	
Supports clocked operation	No	Status display	Green LED per channel
Number of inputs	32	Interrupts	None
Length of cable		Diagnostic functions	None
• Unshielded	max. 600 m		
• Shielded	max. 1000 m	Data for Selecting a Sensor	
Voltages, Currents, Potentials		Input voltage	
Number of inputs that can be triggered simultaneously		• Rated value	24 VDC
• Horizontal configuration		• For signal "1"	13 to 30 V
Up to 40 °C	32	• For signal "0"	-30 to + 5 V
Up to 60 °C	16	Input current	
• Vertical configuration		• At signal "1"	typ. 7 mA
Up to 40 °C	32	Input delay	
Isolation		• At "0" to "1"	1.2 to 4.8 ms
• Between channels and backplane bus	Yes	• At "1" to "0"	1.2 to 4.8 ms
• Between the channels in groups of	16	Input characteristic curve	According to IEC 61131, type 1
Permitted potential difference		Connection of Two-Wire BEROs	Possible
• Between the different circuits	75 VDC / 60 VAC	• Permitted bias current	max. 1.5 mA

3.6 Digital Input Module SM 321; DI 32 × 120 VAC; (6ES7 321-1EL00-0AA0)

Order number

6ES7 321-1EL00-0AA0

Characteristics

The SM 321; DI 32 × 120 VAC features the following characteristics:

- 32 inputs, isolated in groups of 8
- 120 VAC rated input voltage
- Suitable for switches and two / three-wire AC proximity switches

Terminal assignment and block diagram of the SM 321; DI 32 × 120 VAC

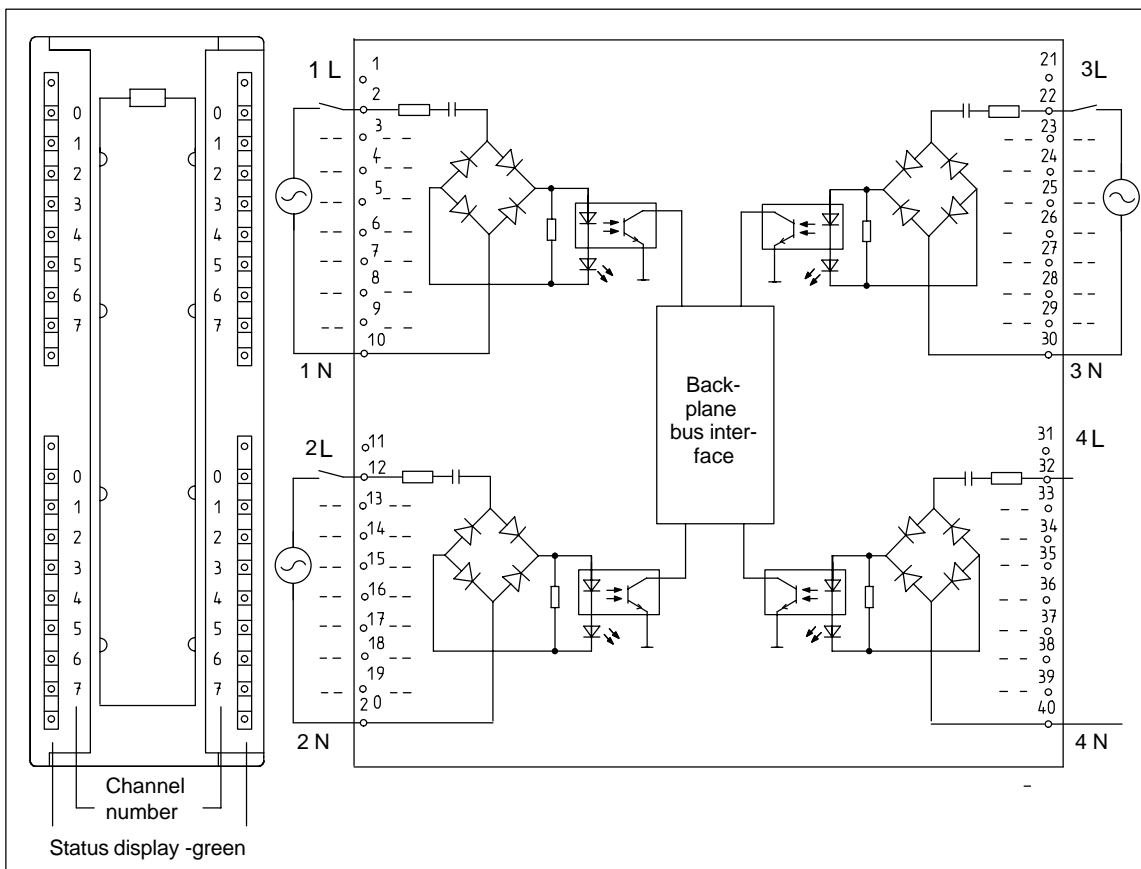

Figure 3-3 Module View and Block Diagram of Digital Input Module SM 321; DI 32 × 120 VAC

Technical specifications of the SM 321; DI 32 × 120 VAC

Dimensions and Weight		Status, Interrupts, Diagnostics	
Dimensions W × H × D (in millimeters)	40 × 125 × 117	Status display	Green LED per channel
Weight	Approx. 300 g	Interrupts	None
Data for Specific Module		Diagnostic functions	None
Supports clocked operation	No	Data for Selecting a Sensor	
Number of inputs	32	Input voltage	
Length of cable		• Rated value	120 VAC
• Unshielded	max. 600 m	• For "1" signal	74 to 132 V
• Shielded	max. 1000 m	• For "0" signal	0 to 20 V
Voltages, Currents, Potentials		• Frequency range	47 to 63 Hz
Number of inputs that can be triggered simultaneously		Input current	
• Horizontal configuration		• At "1" signal	typ. 21 mA
Up to 40 °C	32	Input delay	
Up to 60 °C	24	• From "0" to "1"	max. 15 ms
• Vertical configuration		• From "1" to "0"	max. 25 ms
Up to 40 °C	32	Input characteristic curve	According to IEC 61131, type 2
Isolation		Connection of Two-Wire BEROs	Possible
• Between channels and backplane bus	Yes	• Permitted bias current	max. 4 A
• Between the channels	Yes		
In groups of	8		
Permitted potential difference			
• Between M _{internal} and the inputs	120 VAC		
• Between the inputs of the different groups	250 VAC		
Insulation tested with	2500 VDC		
Current consumption			
• From the backplane bus	max. 16 mA		
Power dissipation of the module	typ. 4 W		

3.7 Digital Input Module SM 321; DI 16 × 24 VDC; (6ES7 321-1BHx2-0AA0)

Order number: "Standard module"

6ES7 321-1BH02-0AA0

Order number: "SIMATIC Outdoor module"

6ES7 321-1BH82-0AA0

Characteristics

The digital input module SM 321; DI 16 × 24 VDC has the following salient features:

- 16 inputs, isolated in groups of 16
- 24 VDC rated input voltage
- Suitable for switches and two / three / four-wire BEROs (proximity switches).

Terminal assignment and block diagram of the SM 321; DI 16 × 24 VDC

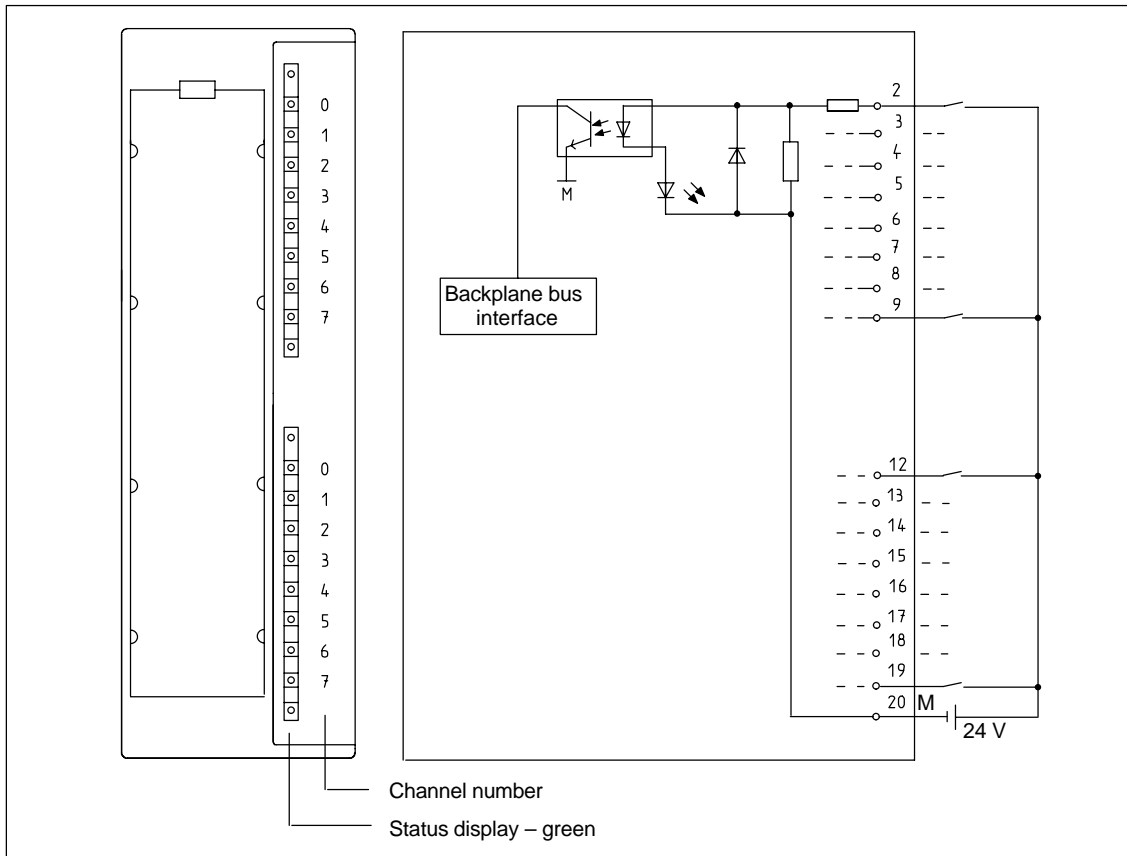

Figure 3-4 Module View and Block Diagram of Digital Input Module SM 321; DI 16 × 24VDC

Technical specifications of the SM 321; DI 16 × 24 VDC

Dimensions and Weight		Data for Selecting a Sensor	
Dimensions W × H × D (in millimeters)	40 × 125 × 117	Input voltage	
Weight	Approx. 200 g	<ul style="list-style-type: none"> Rated value For signal "1" For signal "0" 	24 VDC 13 to 30 V -30 to + 5 V
Data for Specific Module		Input current	
Supports clocked operation	No	<ul style="list-style-type: none"> At signal "1" 	typ. 7 mA
Number of inputs	16	Input delay	
Length of cable		<ul style="list-style-type: none"> At "0" to "1" At "1" to "0" 	1.2 to 4.8 ms 1.2 to 4.8 ms
<ul style="list-style-type: none"> Unshielded Shielded 	max. 600 m max. 1000 m	Input characteristic curve	According to IEC 61131, type 1
Voltages, Currents, Potentials		Connection of Two-Wire BEROs	Possible
Number of inputs that can be triggered simultaneously		<ul style="list-style-type: none"> Permitted bias current 	max. 1.5 mA
<ul style="list-style-type: none"> Horizontal configuration Up to 60 °C Vertical configuration Up to 40 °C 	16 16		
Isolation			
<ul style="list-style-type: none"> Between channels and backplane bus 	Yes		
Permitted potential difference			
<ul style="list-style-type: none"> Between the different circuits 	75 VDC / 60 VAC		
Insulation tested with	500 VDC		
Current consumption			
<ul style="list-style-type: none"> From the backplane bus 	max. 10 mA		
Power dissipation of the module	typ. 3.5 W		
Status, Interrupts, Diagnostics			
Status display	Green LED per channel		
Interrupts	None		
Diagnostic functions	None		

3.8 Digital Input Module SM 321; DI 16 × 24 VDC High Speed; (6ES7 321-1BH10-0AA0)

Order number:

6ES7 321-1BH10-0AA0

Characteristics

The SM 321; DI 16 × 24 VDC High Speed has the following salient features:

- 16 inputs, isolated in groups of 16
- 24 VDC rated input voltage
- Suitable for switches and two / three / four-wire BEROs (proximity switches).
- Supports clocked operation

Terminal assignment and block diagram of the SM 321; DI 16 × 24 VDC High Speed

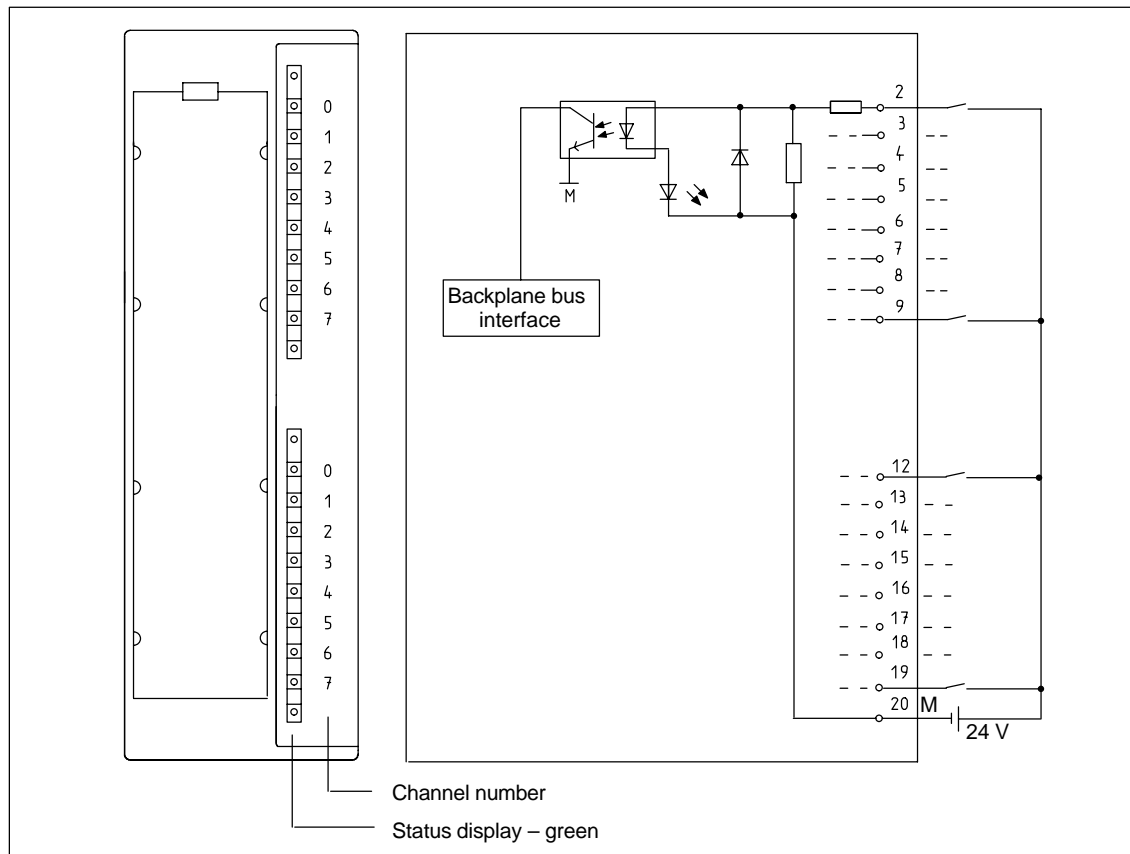

Figure 3-5 Module View and Block Diagram of the SM 321; DI 16 × 24 VDC High Speed

Technical specifications of the SM 321; DI 16 × 24 VDC High Speed

Dimensions and Weight		Data for Selecting a Sensor	
Dimensions W × H × D (in millimeters)	40 × 125 × 117	Input voltage	
Weight	Approx. 200 g	• Rated value	24 VDC
Data for Specific Module		• For signal "1"	13 to 30 V
Supports clocked operation	Yes	• For signal "0"	-30 to + 5 V
Number of inputs	16	Input current	
Length of cable		• At signal "1"	typ. 7 mA
• Unshielded	max. 600 m	Input delay	
• Shielded	max. 1000 m	• At "0" to "1"	25 to 75 μs
Voltages, Currents, Potentials		• At "1" to "0"	25 to 75 μs
Number of inputs that can be triggered simultaneously		Input characteristic curve	According to IEC 61131, type 1
• Horizontal configuration		Connection of Two-Wire BEROs	Possible
Up to 60 °C	16	• Permitted bias current	max. 1.5 mA
• Vertical configuration			
Up to 40 °C	16		
Isolation			
• Between channels and backplane bus	Yes		
Permitted potential difference			
• Between the different circuits	75 VDC / 60 VAC		
Insulation tested with	500 VDC		
Current consumption			
• From the backplane bus	max. 110 mA		
Power dissipation of the module	typ. 3.8 W		
Status, Interrupts, Diagnostics			
Status display	Green LED per channel		
Interrupts	None		
Diagnostic functions	None		

3.9 Digital Input Module SM 321; DI 16 × 24 VDC; with Hardware and Diagnostic interrupts; (6ES7 321-7BHx0-0AB0)

Order number: "Standard module"

6ES7 321-7BH00-0AB0

Order number: "SIMATIC Outdoor module"

6ES7 321-7BH80-0AB0

Characteristics

The SM 321; DI 16 × 24 VDC; with hardware and diagnostic interrupts features the following characteristics:

- 16 inputs, isolated in groups of 16
- 24 VDC rated input voltage
- Input characteristic curve according to IEC 61131, Type 2
- Suitable for switches and two / three / four-wire BEROs (proximity switches).
- 2 short-circuit-proof sensor supplies for 8 channels each
- External redundant power supply possible to supply sensors
- "Sensor supply (Vs)" status display
- Group error display
- Programmable diagnostics
- Programmable diagnostic interrupt
- Programmable hardware interrupt
- Programmable input delays

Terminal assignment of the SM 321; DI 16 × 24 VDC

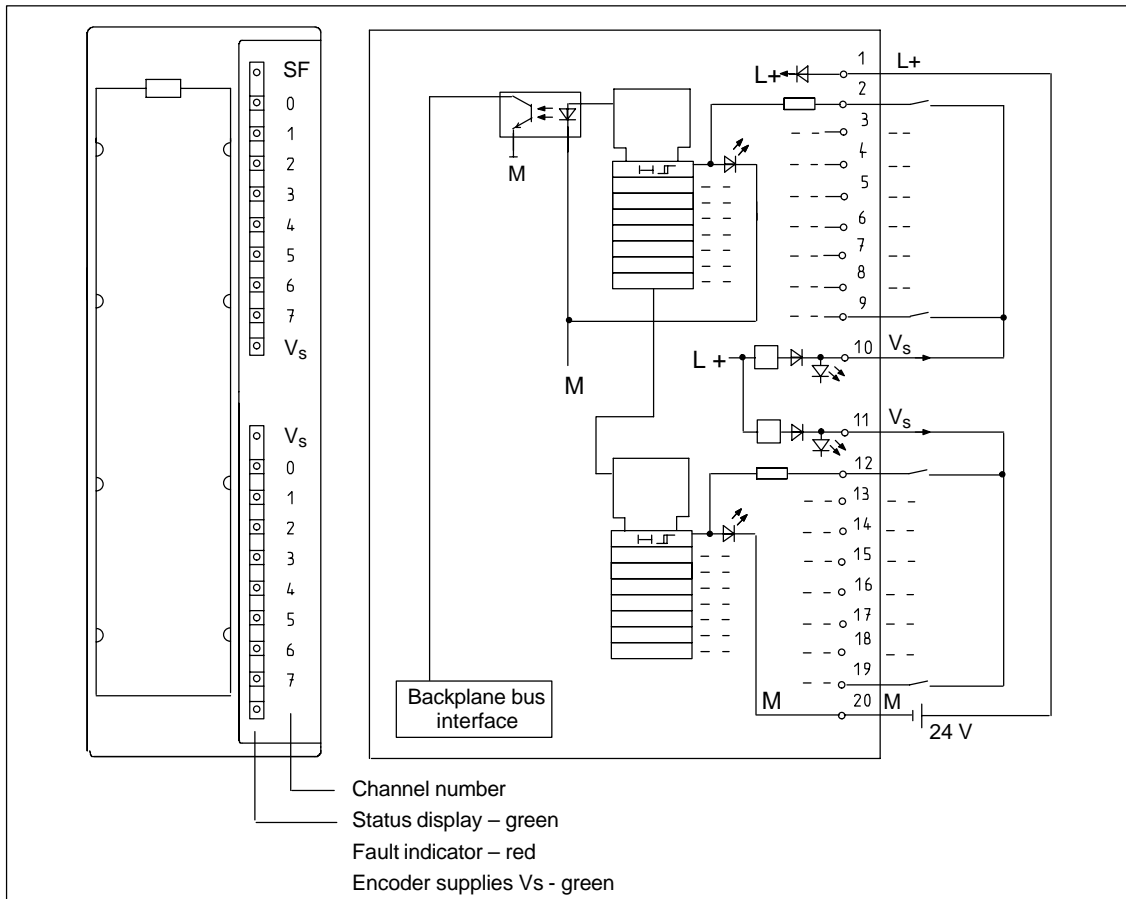

Figure 3-6 Module View and Block Diagram of the SM 321; DI 16 × 24 VDC (6ES7 321-7BHx0-0AB0)

Terminal assignment for redundant supply of encoders

The figure below shows how encoder can additionally be supplied by means of Vs with a redundant voltage source – for example, via another module).

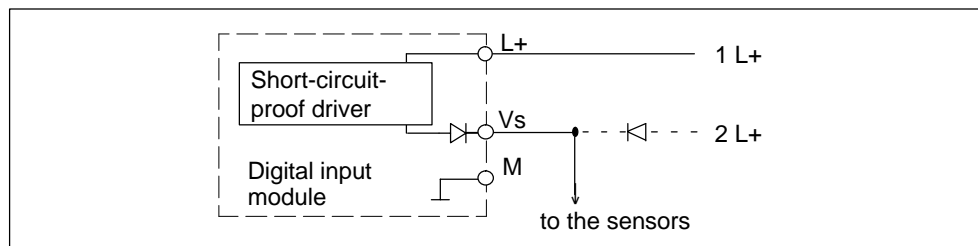

Figure 3-7 Terminal Assignment for the Redundant Supply of Encoders of the SM 321; DI 16 × 24 VDC (6ES7 321-7BHx0-0AB0)

Technical specifications of the SM 321; DI 16 × 24 VDC

Dimensions and Weight	
Dimensions W × H × D (in millimeters)	40 × 125 × 117
Weight	Approx. 200 g
Data for Specific Module	
Supports clocked operation	No
Number of inputs	16
Length of cable	
• Unshielded	max. 600 m
• Shielded	max. 1000 m
Voltages, Currents, Potentials	
Power rated voltage of the electronics and encoder L+	24 VDC
• Reverse polarity protection	Yes
Number of inputs that can be triggered simultaneously	
• Horizontal configuration	
• Up to 60 °C	16
• Vertical configuration	
• Up to 40 °C	16
Isolation	
• Between channels and backplane bus	Yes
Permitted potential difference	
• Between the different circuits	75 VDC / 60 VAC
Insulation tested with	500 VDC
Current consumption	
• From the backplane bus	max. 55 mA
• From load voltage L + (without sensor supply V _S)	max. 40 mA
Power dissipation of the module	typ. 4 W
Status, Interrupts, Diagnostics	
Status display	
• Inputs	Green LED per channel
• Sensor power supplies (V _S)	Green LED per output
Interrupts	
• Hardware interrupt	Parameters can be assigned
• Diagnostic Interrupt	Parameters can be assigned
Diagnostic functions	Parameters can be assigned
• Group error display	Red LED (SF)
• Diagnostics information read-out	Possible
Sensor Power Supply Outputs	
Number of outputs	2
Output voltage	
• With load	min. L+ (-2.5 V)
Output current	
• Rated value	120 mA
• Permitted range	0 to 150 mA
Additional (redundant) supply	Permitted
Short-circuit protection	Yes, electronic
Data for Selecting a Sensor	
Input voltage	
• Rated value	24 VDC
• For signal "1"	13 to 30 V
• For signal "0"	-30 to +5 V
Input current	
• At signal "1"	typ. 7 mA
Input characteristic curve	According to IEC 61131, type 2
Connection of Two-Wire BEROs	Possible
• Permitted bias current	max. 2 mA
Time/Frequency	
Internal preparation time for	
• Only interrupt processing	max. 250 μs
• Interrupt and diagnostics processing	max. 250 μs
Input delay	
• Parameters can be assigned	Yes
• Rated value	typ. 0.1/0.5/3/15/20 ms

3.9.1 Assigning Parameters to the SM 321; DI 16 × 24 VDC

Parameter assignment

You will find a description of the general procedure for assigning parameters to digital modules in Section 3.3.

Parameters of the SM 321; DI 16 × 24 VDC

You will find an overview of the parameters that you can set and their default settings for the SM 321; DI 16 × 24 VDC in the table below.

The default settings apply if you have not performed parameter assignment in *STEP 7*.

Table 3-8 Parameters of the SM 321; DI 16 × 24 VDC (6ES7 321-7BHx0-0AB0)

Parameter	Value Range	Default Settings	Parameter Type	Scope
Enable <ul style="list-style-type: none"> Diagnostic interrupt Hardware interrupt 	Yes/no Yes/no	No No	Dynamic	Module
Input delay/voltage type	0.1 ms (DC) 0.5 ms (DC) 3 ms (DC) 15 ms (DC) 20 ms (DC/AC)	3 (DC)	Static	Module
Diagnostics <ul style="list-style-type: none"> Sensor supply missing 	Yes/no	No	Static	Channel group
Trigger for hardware interrupt <ul style="list-style-type: none"> Rising edge Falling edge 	Yes/no Yes/no	No No	Dynamic	Channel group

Assignment of the encoder supplies to channel groups

The two encoder supplies of the module are used to supply two channel groups: inputs 0 to 7 and inputs 8 to 15. In these two channel groups, you parameterize the diagnostics for the encoder supply, too.

Assigning interrupt parameters to channel groups

The table below shows the channels that can be combined to form a channel group if you would like to parameterize interrupt processing.

You will need the channel group number to set the parameters in the user program with an SFC.

Table 3-9 Assigning the Interrupt Parameters to the Inputs of the SM 321; DI 16 × 24 VDC (6ES7 321-7BHx0-0AB0)

Parameter...	Can Be Set in Following Channel Groups	Channel Group Number
Hardware interrupt (for falling, rising or both types of pulse edges)	0 and 1	0
	2 and 3	1
	4 and 5	2
	6 and 7	3
	8 and 9	4
	10 and 11	5
	12 and 13	6
Diagnostic Interrupt (with missing encoder supply)	14 and 15	7
	0 to 7 8 to 15	-

Tolerances of the programmable input delays

Table 3-10 Tolerances of the Input Delays of SM 321; DI 16 × 24 VDC (6ES7 321-7BHx0-0AB0)

Programmed Input delay	Tolerance
0.1 ms	87.5 to 112.5 μs
0.5 ms	0.43 to 0.57 ms
3 ms (preset)	2.62 to 3.38 ms
15 ms	13.1 to 16.9 ms
20 ms	20 to 25 ms

3.9.2 Behavior and Diagnostics of the SM 321; DI 16 × 24 VDC

Effect of operating and mode supply voltage on the input values

The input values of the SM 321; DI 16 × 24 DC depend on the operating mode of the CPU and on the supply voltage of the module.

Table 3-11 Dependencies of Input Values on the Operating Mode of the CPU and Supply Voltage L+ of the SM 321; DI 16 × 24 VDC (6ES7 321-7BHx0-0AB0)

CPU Operating State		Power Supply L+ to Digital Module	Input Value of Digital Module
POWER ON	RUN	L+ exists	Process value
		L+ missing	0 signal
	STOP	L+ exists	Process value
		L+ missing	0 signal
POWER OFF	–	L+ exists	–
		L+ missing	–

Diagnostic Messages of the SM 321; DI 16 × 24 VDC

The table below presents an overview of the diagnostic messages for the SM 321; DI 16 × 24 VDC.

Table 3-12 Diagnostic Messages of the SM 321; DI 16 × 24 VDC (6ES7 321-7BHx0-0AB0)

Diagnosics Message	LED	Scope of the Diagnostics	Parameters can be assigned
Sensor supply missing	SF	Channel group	Yes
External auxiliary supply missing	SF	Module	No
Internal auxiliary power missing	SF	Module	
Fuse blown	SF	Module	
Incorrect parameter on module	SF	Module	
Watchdog timeout	SF	Module	
EPROM error	SF	Module	
RAM error	SF	Module	
Hardware interrupt lost	SF	Module	

Note

A prerequisite for detecting the errors indicated by programmable diagnostic messages is that you have assigned parameters to the digital module accordingly in *STEP 7*.

Behavior upon failure of the supply voltage

A failure of the supply voltage of the SM 321; DI 16 × 24 DC is always indicated by the SF LED on the module. Furthermore, this information is made available on the module.

The input value is initially held for 20 to 40 ms before the 0 signal is transferred to the CPU. Supply voltage dips < 20 ms do not modify the process value (refer to Table 3-11).

Triggering of the diagnostic interrupt depends on the parameter assignment (see Section 3.9.3).

Failure of the supply voltage with redundant encoder incoming supply

Note

If an external redundant source is applied simultaneously to the sensor supply (Vs), a failure in the internal sensor supply causes a failure of the internal and/or external sensor supply and/or a blown fuse to be indicated instead of a regular sensor supply failure.

Short-circuit of sensor supply Vs

Irrespective of the parameter assignment, the corresponding Vs LED goes out if a short-circuit of the encoder supply Vs occurs.

Causes of error and remedial measures

Table 3-13 Diagnostic Messages of the SM 321; DI 16 × 24 VDC (6ES7 321-7BHx0-0AB0), Causes of Error and Remedial Measures

Diagnosics Message	Possible Error Cause	Remedy
Lack of encoder supply	Overload of sensor supply	Eliminate overload
	Short circuit of sensor supply to M	Eliminate short circuit
External auxiliary voltage missing	Power supply L+ to module missing	Feed supply L+
Internal auxiliary voltage missing	Power supply L+ to module missing	Feed supply L+
	Fuse in module defective	Replace module
Fuse blown	Fuse in module defective	Replace module
Wrong parameters in module	One parameter or the combination of parameters is not plausible	Reassign module parameter
Watchdog tripped	Temporary high electromagnetic interference	Eliminate interference
	Module defective	Replace module
EPROM error	Temporary high electromagnetic interference	Eliminate interference and switch on/off power supply of CPU
	Module defective	Replace module
RAM error	Temporary high electromagnetic interference	Eliminate interference and switch on/off power supply of CPU
	Module defective	Replace module
Hardware interrupt lost	The module cannot send an interrupt, since the previous interrupt was not acknowledged; configuration error possible	Change interrupt processing in CPU and reconfigure module parameters, if required The error continues until the module is configured with new parameters

3.9.3 Interrupts of the SM 321; DI 16 × 24 VDC

Introduction

This section describes the SM 321; DI 16 × 24 VDC with regard to its interrupt behavior. The following interrupts exist:

- Diagnostic Interrupt
- Hardware interrupt

The OBs and SFCs mentioned below can be found in the online Help for *STEP 7*, where they are described in greater detail.

Enabling interrupts

The interrupts are not preset – in other words, they are inhibited without appropriate parameter assignment. Assign parameters to the Interrupt Enable in *STEP 7* (refer to Section 3.9.1).

Diagnostic interrupt

If you have enabled diagnostic interrupts, then active error events (initial occurrence of the error) and departing error events (message after troubleshooting) are reported by means of an interrupt.

The CPU interrupts the execution of the user program and processes the diagnostic interrupt block (OB 82).

In the user program, you can call SFC 51 or SFC 59 in OB 82 to obtain more detailed diagnostic information from the module.

The diagnostic information is consistent until such time as OB 82 is exited. When OB 82 is exited, the diagnostic interrupt is acknowledged on the module.

Hardware interrupt

The SM 321; DI 16 × 24 VDC can trigger a hardware interrupt for every channel group with a rising or falling edge, or both, of a signal status change.

Perform parameter assignment one channel group at a time. It can be modified at any time (in RUN mode using the user program).

Pending hardware interrupts trigger hardware interrupt processing in the CPU (OB 40). The CPU interrupts the execution of the user program or of the priority classes with low priority.

You can set in the user program of the hardware interrupt OB (OB 40) how the programmable logic controller has to react to an edge change. When the hardware interrupt OB is exited, the hardware interrupt is acknowledged on the module.

The module can buffer one interrupt per channel. If no higher priority run-time levels are waiting to be processed, the buffered interrupts (of all modules) are serviced one after the other by the CPU according to the order in which they occurred.

Hardware interrupt lost

If an interrupt has been buffered for a channel and another interrupt occurs on that channel before it has been processed by the CPU, a diagnostic interrupt "hardware interrupt lost" is triggered.

More interrupts on this channel are not acquired until processing of the interrupt buffered on this channel has been executed.

Interrupt-triggering channels

The interrupt-triggering channels are stored in the local data of the hardware interrupt OBs (in the OB start information). The start information is two words long (bits 0 to 31). The bit number is the channel number. Bits 16 to 31 are not assigned.

3.10 Digital Input Module SM 321; DI 16 × DC 24 V; Source Input; (6ES7 321-1BH50-0AA0)

Order number

6ES7 321-1BH50-0AA0

Characteristics

The SM 321; DI 16 × 24 VDC (source input) has the following salient features:

- 16 inputs, source input, isolated in groups of 16
- 24 VDC rated input voltage
- Suitable for switches and two- / three- / four-wire BEROs (proximity switches).

Terminal assignment and block diagram of the SM 321; DI 16 × 24 VDC

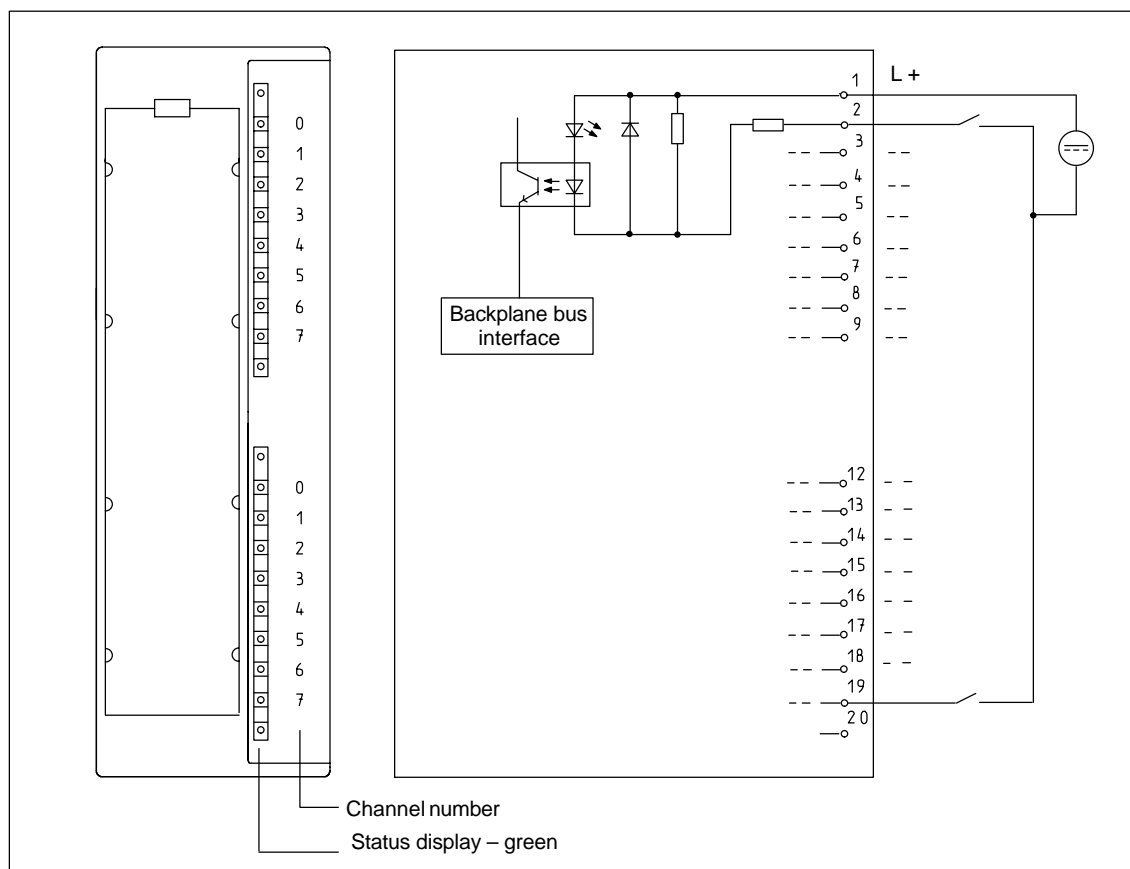

Figure 3-8 Module View and Block Diagram of Digital Input Module SM 321; DI 16 × 24 VDC (Source Input)

Technical specifications of the SM 321; DI 16 × 24 VDC

Dimensions and Weight		Data for Selecting a Sensor	
Dimensions W × H × D (in millimeters)	40 × 125 × 117	Input voltage (reference potential is L+)	
Weight	Approx. 200 g	<ul style="list-style-type: none"> Rated value For signal "1" For signal "0" 	24 VDC -13 V to -30 V +30 V to -5 V
Data for Specific Module		Input current	
Supports clocked operation	No	<ul style="list-style-type: none"> At signal "1" 	typ. 7 mA
Number of inputs	16	Input delay	
Length of cable		<ul style="list-style-type: none"> At "0" to "1" At "1" to "0" 	1.2 to 4.8 ms 1.2 to 4.8 ms
<ul style="list-style-type: none"> Unshielded Shielded 	max. 600 m max. 1000 m	Input characteristic curve	According to IEC 61131, type 1
Voltages, Currents, Potentials		Connection of Two-Wire BEROs	Possible
Number of inputs that can be triggered simultaneously		<ul style="list-style-type: none"> Permitted bias current 	max. 1.5 mA
<ul style="list-style-type: none"> Horizontal configuration Up to 60 °C Vertical configuration Up to 40 °C 	16 16		
Isolation			
<ul style="list-style-type: none"> Between channels and backplane bus 	Yes		
Permitted potential difference			
<ul style="list-style-type: none"> Between the different circuits 	75 VDC / 60 VAC		
Insulation tested with	500 VDC		
Current consumption			
<ul style="list-style-type: none"> From the backplane bus 	max. 10 mA		
Power dissipation of the module	typ. 3.5 W		
Status, Interrupts, Diagnostics			
Status display	Green LED per channel		
Interrupts	None		
Diagnostics functions	None		

3.11 Digital Input Module SM 321; DI 16 × UC 24/48 V (6ES7 321-1CH00-0AA0)

Order number

6ES7 321-1CH00-0AA0

Characteristics

The SM 321; DI 16 × UC24/48 V features the following characteristics:

- 16 inputs, isolated electrically
- Electrical isolation between channels of 120 V
- Rated input voltage from 24 to 48 DC)
- Inputs are fully independent and can be connected in any required configuration

Terminal assignment and block diagram of the SM 321; DI 16 × 24/48 VUC

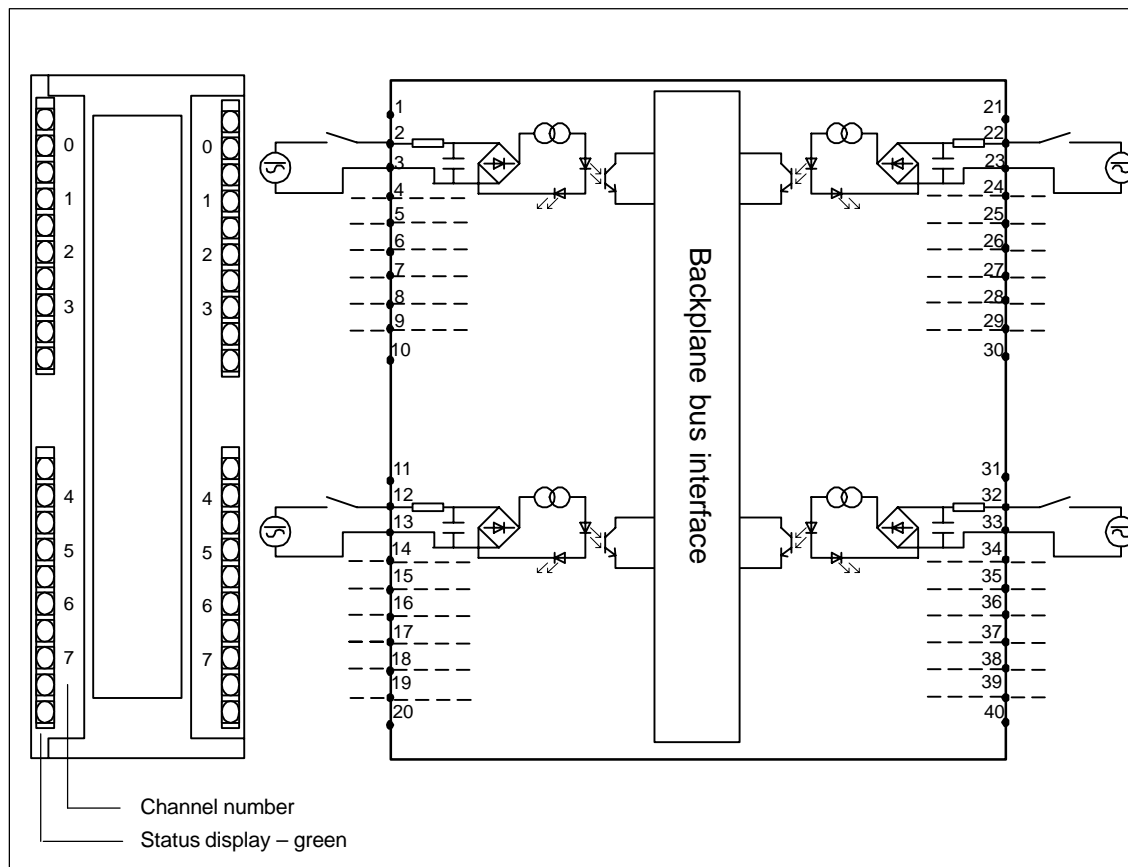

Figure 3-9 Module View and Block Diagram of Digital Input Module SM 321; DI 16 × 24/48VUC

Technical specifications of the SM 321; DI 16 × 24/48 VUC

Dimensions and Weight		Status, Interrupts, Diagnostics	
Dimensions W × H × D	40 × 125 × 117	Status display	Green LEDs per channel
Weight	Approx. 260 g	Interrupts	None
Data for Specific Module		Diagnostic functions	None
Supports clocked operation	No		None
Number of inputs	16	Data for Selecting a Sensor	
Length of cable		Input voltage	
• Unshielded	max. 600 m	• Rated value	24 or 48 VDC/ 24 or 48 VAC
• Shielded	max. 1000 m	• At signal "1"	14 V to 60 V
Voltages, Currents, Potentials		• At signal "0"	-5 V to 5 V
Number of inputs that can be triggered simultaneously		• Frequency range	0 to 63 Hz
• Horizontal configuration up to 60°C	16	Input current	
• All other configuration types up to 40° C	16	• At signal "1"	typ. 2.7 mA
Isolation		• At signal "0"	-1 to +1 mA
• Between channels and backplane bus	Yes	Input delay	
• Between channels in groups of	Yes 1	• At "0" to "1"	max. 16 ms
Permitted potential difference		• At "1" to "0"	max. 16 ms
• Between the channels and the backplane bus	170 VDC, 120 VAC	Input characteristic curve	According to IEC 61131, type 1
• Between the inputs of the different groups	170 VDC, 120 VAC	Connection of Two-Wire BEROs	Possible
Insulation tested with		• Permitted bias current	max. 1 mA
• Between the channels and the backplane bus	1500 VAC		
• Between the inputs of the different groups	1500 VAC		
Current consumption			
• From the backplane bus	max. 100 mA		
Power dissipation of the module			
• Operation with 24 V	typ. 1.5 W		
• Operation with 48 V	typ. 2.8 W		

3.12 Digital Input Module SM 321; DI 16 × 48-125 VDC; (6ES7 321-1CH80-0AA0)

Order number: "SIMATIC Outdoor module"

6ES7 321-1CH80-0AA0

Characteristics

The SM 321; DI 16 × 48-125 VDC features the following characteristics:

- 16 inputs, isolated in groups of 8
- Rated input voltage 48 to 125 VDC
- Suitable for switches and two / three / four-wire BEROs (proximity switches).

Terminal assignment and block diagram of the SM 321; DI 16 × 48-125 VDC

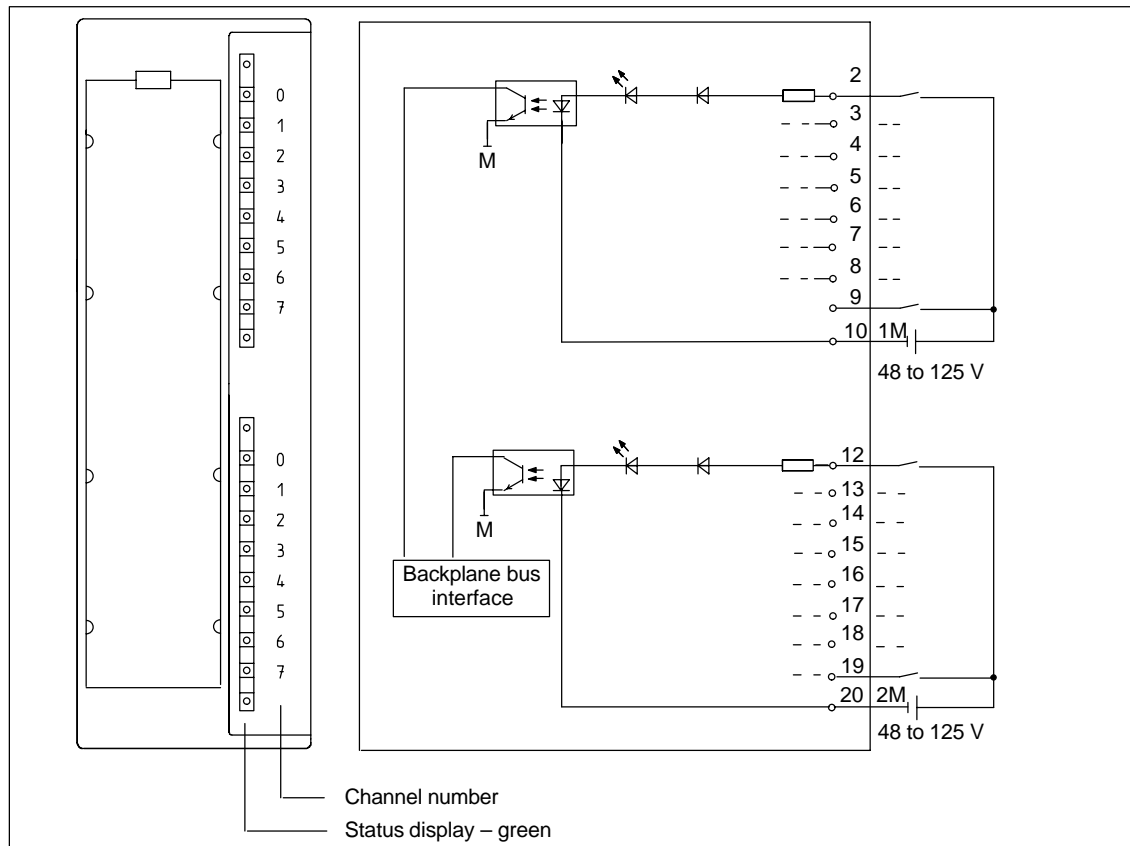

Figure 3-10 Module View and Block Diagram of SM 321; DI 16 × 48-125 VDC

Technical specifications of the SM 321; DI 16 × 48-125 VDC

Dimensions and Weight		Status, Interrupts, Diagnostics	
Dimensions W × H × D (in millimeters)	40 × 125 × 120	Status display	Green LED per channel
Weight	Approx. 200 g	Interrupts	None
Data for Specific Module		Diagnostic functions	None
Supports clocked operation	No	Sensor Selection Data	
Number of inputs	16	Input voltage	
Length of cable		• Rated value	48 VDC to 125 VDC
• Unshielded	max. 600 m	• For signal "1"	30 V to 146 V
• Shielded	max. 1000 m	• For signal "0"	-146 V to 15 V
Voltages, Currents, Potentials		Input current	
Number of inputs that can be triggered simultaneously at U _E	Up to 60 V Up to 146 V	• At signal "1"	typ. 3.5 mA
• Horizontal installation		Input delay	
Up to 50 °C	8 8	• At "0" to "1"	0.1 ms to 3.5 ms
Up to 60 °C	8 6	• At "1" to "0"	0.7 ms to 3.0 ms
• Vertical configuration		Input characteristic curve	According to IEC 61131, type 1
Up to 40 °C	8 8	Connection of Two-Wire BEROs	Possible
Isolation		• Permitted bias current	max. 1 mA
• Between channels and backplane bus	Yes		
• Between the channels	Yes		
In groups of	8		
Permiss. potential differences			
• Between the different circuits	146 VDC / 132 VAC		
Insulation tested with	1500 VDC		
Current consumption			
• From the backplane bus	max. 40 mA		
Power dissipation of the module	typ. 4.3 W		

3.13 Digital Input Module SM 321; DI 16 × AC 120/230 V (6ES7 321-1FH00-0AA0)

Order number

6ES7 321-1FH00-0AA0

Characteristics

The SM 321; DI 16 × 120/230 VAC features the following characteristics:

- 16 inputs, electrically isolated in groups of 4
- 120/230 VAC rated input voltage
- Suitable for switches and two / three-wire proximity switches (alternating voltage)

Terminal assignment and block diagram of the SM 321; DI 16 x 120/230 VAC

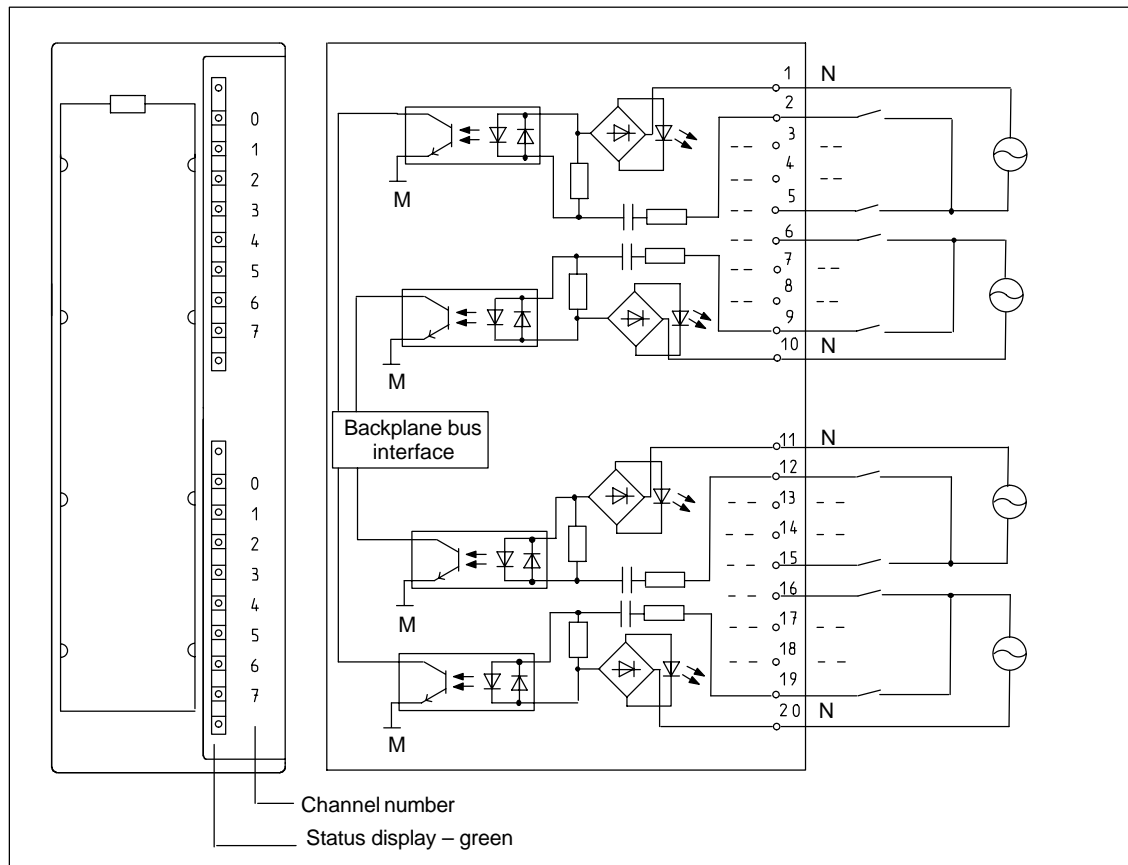

Figure 3-11 Module View and Block Diagram of the SM 321; DI 16 × 120/230 VAC

Technical specifications of the SM 321; DI 16 x 120/230 VAC

Dimensions and Weight		Status, Interrupts, Diagnostics	
Dimensions W × H × D (in millimeters)	40 × 125 × 117	Status display	Green LED per channel
Weight	Approx. 240 g	Interrupts	None
Data for Specific Module		Diagnostic functions	None
Supports clocked operation	No	Sensor Selection Data	
Number of inputs	16	Input voltage	
Length of cable		• Rated value	120/230 VAC
• Unshielded	max. 600 m	• For signal "1"	79 to 264 V
• Shielded	max. 1000 m	• For signal "0"	0 to 40 V
Voltages, Currents, Potentials		• Frequency range	47 to 63 Hz
Rated load voltage L1	120/230 V	Input current	
All load voltages must be of the same phase		• At signal "1"	
Number of inputs that can be triggered simultaneously		120 V, 60 Hz	typ. 8.0 mA
• Horizontal configuration Up to 60 °C	16	230 V, 50 Hz	typ. 16.0 mA
• Vertical configuration Up to 40 °C	16	Input delay	
Isolation		• "0" to "1"	max. 25 ms
• Between channels and backplane bus	Yes	• "0" to "1"	max. 25 ms
• Between channels In groups of	Yes 4	Input characteristic curve	According to IEC 61131, type 1
Permitted potential difference		Connection of Two-Wire BEROs	Possible
• Between M _{internal} and the inputs	500 VAC	• Permitted bias current	max. 2 mA
• Between the inputs of the different groups	230 VAC		
Insulation tested with	4000 VDC		
Current consumption			
• From the backplane bus	max. 29 mA		
Power dissipation of the module	typ. 4.9 W		

3.14 Digital Input Module SM 321; DI 8 × 120/230 VAC; (6ES7 321-1FFx1-0AA0)

Order number: "Standard module"

6ES7 321-1FF01-0AA0

Order number: "SIMATIC Outdoor module"

6ES7 321-1FF81-0AA0

Characteristics

The SM 321; DI 8 × 120/230 VAC features the following characteristics:

- 8 inputs, isolated in groups of 2
- 120/230 VAC rated input voltage
- Suitable for switches and two / three-wire AC proximity switches

Terminal assignment and block diagram of the SM 321; DI 8 × 120/230 VAC

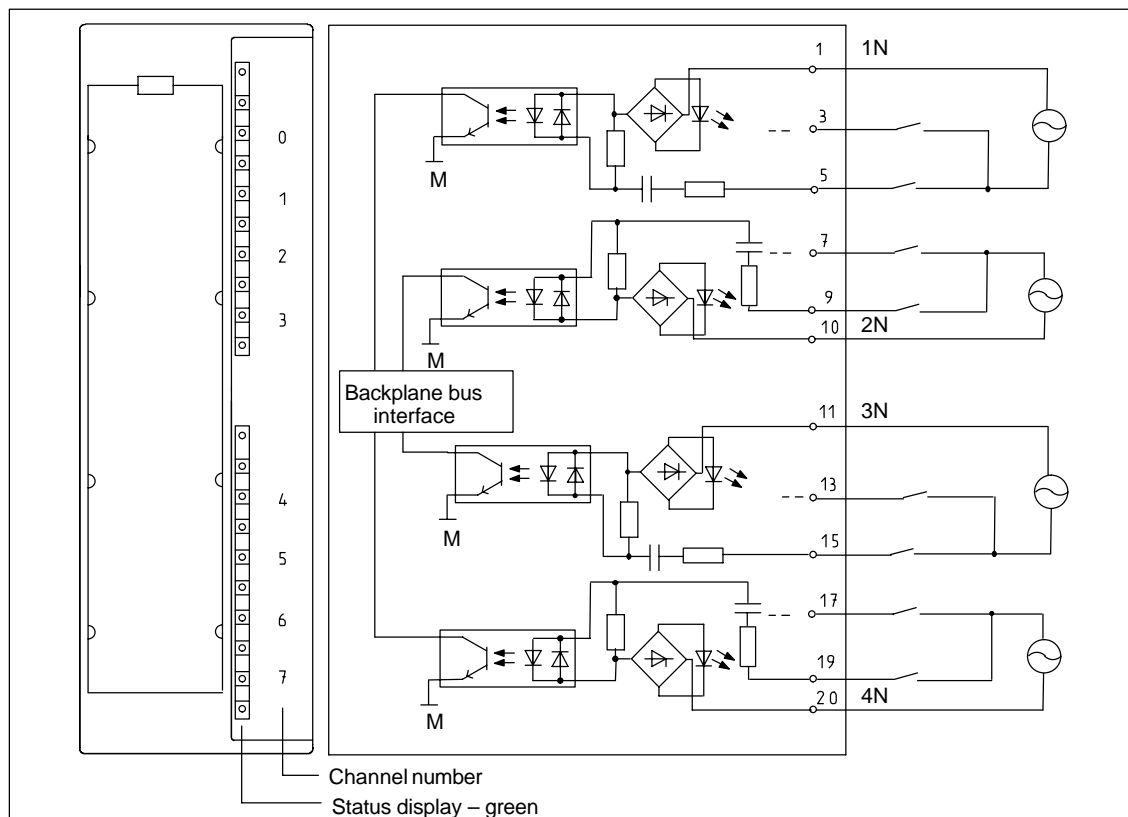

Figure 3-12 Module View and Block Diagram of the SM 321; DI 8 × 120/230 VAC

Technical specifications of the SM 321; DI 8 × 120/230 VAC

Dimensions and Weight		Status, Interrupts, Diagnostics	
Dimensions W × H × D (in millimeters)	40 × 125 × 117	Status display	Green LED per channel
Weight	Approx. 240 g	Interrupts	None
Data for Specific Module		Diagnostic functions	None
Supports clocked operation	No	Data for Selecting a Sensor	
Number of inputs	8	Input voltage	
Length of cable		• Rated value	120/230 VAC
• Unshielded	max. 600 m	• For signal "1"	79 to 264 V
• Shielded	max. 1000 m	• For signal "0"	0 to 40 V
Voltages, Currents, Potentials		• Frequency range	47 to 63 Hz
Number of inputs that can be triggered simultaneously		Input current	
• Horizontal configuration		• At signal "1"	
Up to 60 °C	8	120 V, 60 Hz	typ. 6.5 mA
• Vertical configuration		230 V, 50 Hz	typ. 11 mA
Up to 40 °C	8	Input delay	
Isolation		• At "0" to "1"	max. 25 ms
• Between channels and backplane bus	Yes	• At "1" to "0"	max. 25 ms
• Between the channels	Yes	Input characteristic curve	According to IEC 61131, type 1
In groups of	2	Connection of Two-Wire BEROs	Possible
Permitted potential difference		• Permitted bias current	max. 2 mA
• Between M _{internal} and the inputs	230 VAC		
• Between the inputs of the different groups	500 VAC		
Insulation tested with	4000 VDC		
Current consumption			
• From the backplane bus	max. 29 mA		
Power dissipation of the module	typ. 4.9 W		

3.15 Digital Input Module SM 321; DI 8 × 120/230 VAC ISOL (6ES7 321-1FF10-0AA0)

Order number

6ES7 321-1FF10-0AA0

Characteristics

The digital input module SM 321; DI 8 × 120/230 VAC ISOL has the following distinguishing characteristics:

- 8 outputs, isolated in groups of 1
- 120/230 VAC rated input voltage
- Suitable for switches and two / three / four-wire AC proximity switches

Terminal assignment and block diagram of the SM 321; DI 8 × 120/230 VAC ISOL

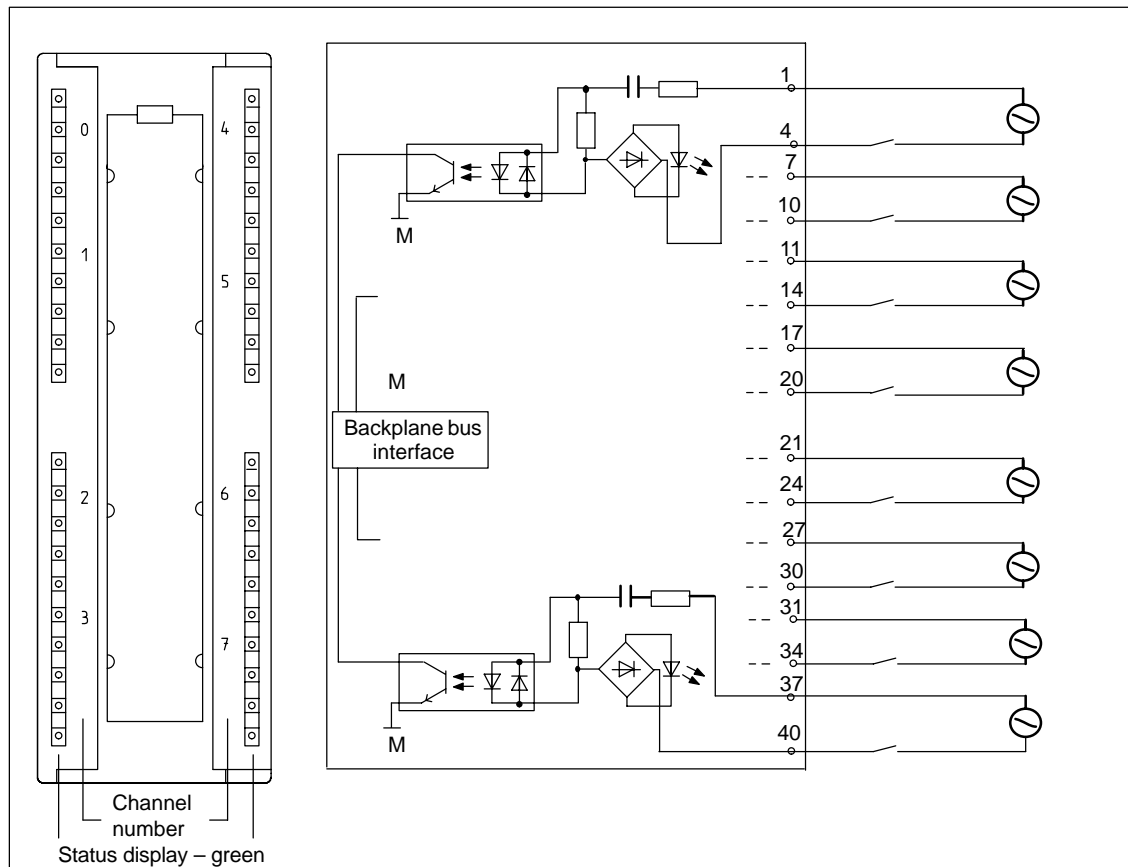

Figure 3-13 Module View and Block Diagram of the SM 321; DI 8 × 120/230 VAC ISOL

Technical specifications of the SM 321; DI 8 × 120/230 VAC ISOL

Dimensions and Weight		Status, Interrupts, Diagnostics	
Dimensions W × H × D (in millimeters)	40 × 125 × 117	Status display	Green LED per channel
Weight	Approx. 240 g	Interrupts	None
Data for Specific Module		Diagnostic functions	None
Supports clocked operation	No	Data for Selecting a Sensor	
Number of inputs	8	Input voltage	
Length of cable		• Rated value	120/230 VAC
• Unshielded	max. 600 m	• For signal "1"	79 to 264 V
• Shielded	max. 1000 m	• For signal "0"	0 to 40 V
Voltages, Currents, Potentials		• Frequency range	47 to 63 Hz
Rated load voltage L1	120/230 VAC	Input current	
All load voltages must be of the same phase		• At signal "1"	
Number of inputs that can be triggered simultaneously		120 V, 60 Hz	typ. 7.5 mA
• Horizontal configuration Up to 60 °C	8	230 V, 50 Hz	typ. 17.3 W
• Vertical configuration Up to 40 °C	8	Input delay	
Isolation		• "0" to "1"	max. 25 ms
• Between channels and backplane bus	Yes	• "0" to "1"	max. 25 ms
• Between channels In groups of	Yes 1	Input characteristic curve	According to IEC 61131, type 1
Permitted potential difference		Connection of Two-Wire BEROs	Possible
• Between M _{internal} and the inputs	230 VAC	• Permitted bias current	max. 2 mA
• Between the inputs of the different groups	500 VAC		
Insulation tested with			
• Between M _{internal} and the inputs	1500 VAC		
• Between the inputs of the different groups	2000 VAC		
Current consumption			
• From the backplane bus	max. 100 mA		
Power dissipation of the module	typ. 4.9 W		

3.16 Digital Output Module SM 322; DO 32 × 24 VDC/ 0.5 A; (6ES7 322-1BL00-0AA0)

Order number

6ES7 322-1BL00-0AA0

Characteristics

The digital output module SM 322; DO 32 × 24 VDC/0.5 A has the following salient features:

- 32 outputs, isolated in groups of 8
- 0.5 A output current
- 24 VDC rated load voltage
- Suitable for solenoid valves, DC contactors and indicator lights

Using the module with high-speed counters

Please take note of the following information on the use of the module in connection with high-speed counters:

Note

When connecting the 24 V power supply via a mechanical contact, the outputs of the SM 322; DO 32 × DC 24 V/0.5 A carry a "1" signal for approximately 50 μs for reasons associated with the circuitry.

Module View and Block Diagram of the SM 322; DO 32 × 24 VDC/ 0.5 A

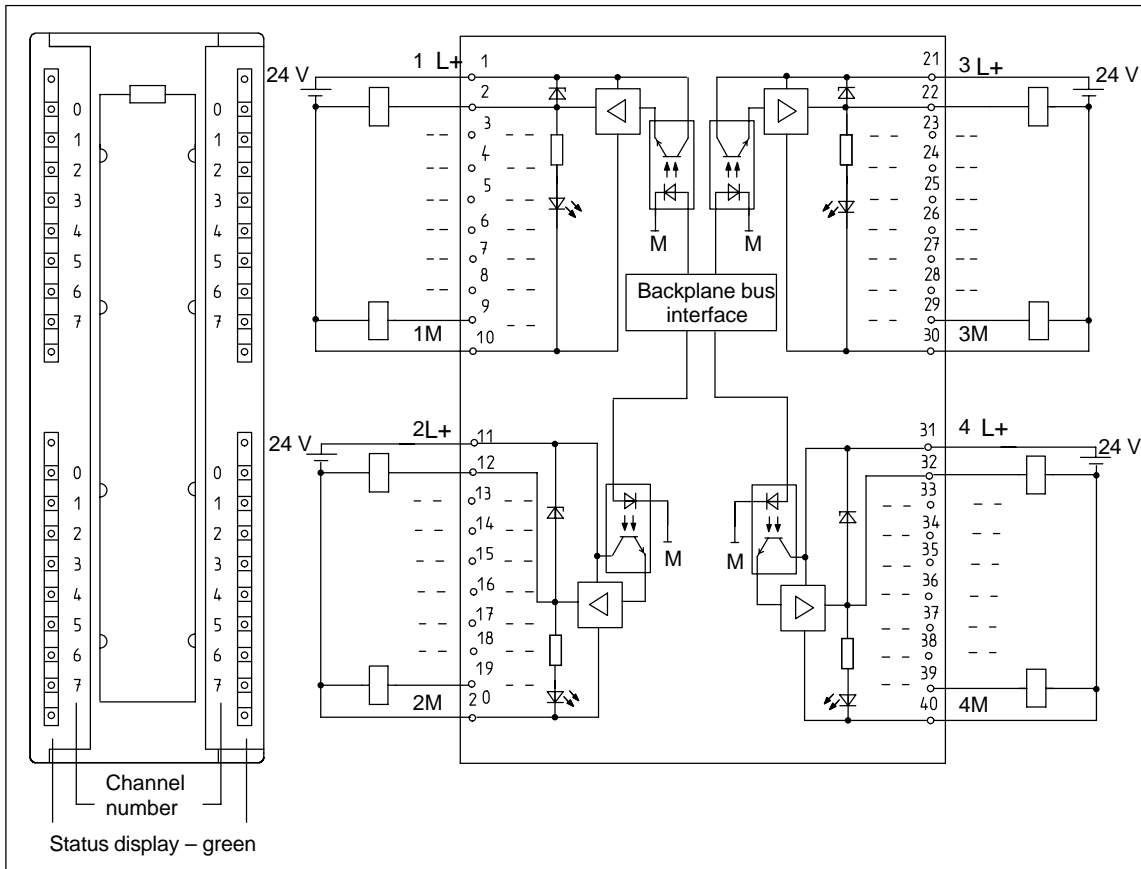

Figure 3-14 Module View and Block Diagram of Digital Output Module SM 322; DO 32 × 24 VDC/0.5 A

Terminal assignment

The following figure shows the assignment of the channels to the addresses.

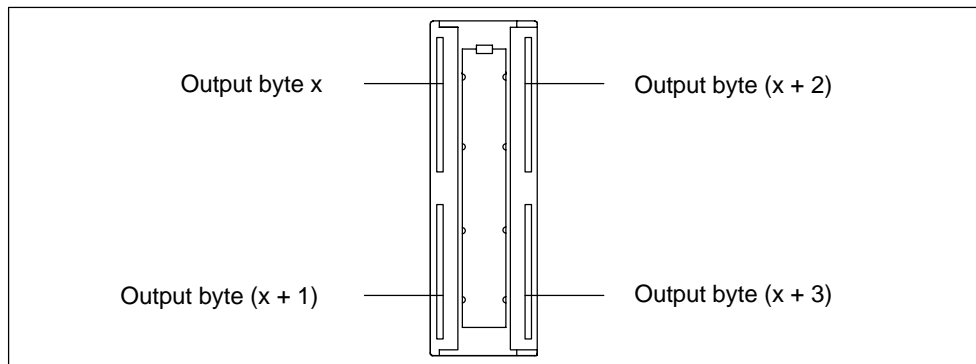

Figure 3-15 Terminal Assignment of the SM 322; DO 32 × 24 VDC

Terminal Assignment of the SM 322; DO 32 × 24 VDC/ 0.5 A

Dimensions and Weight		Data for Selecting an Actuator	
Dimensions W × H × D (in millimeters)	40 × 125 × 117	Output voltage	
Weight	Approx. 260 g	• At signal "1"	min. L + (–0.8 V)
Data for Specific Module		Output current	
Supports clocked operation	No	• At signal "1"	
Number of outputs	32	Rated value	0.5 A
Length of cable		Permitted range	5 mA to 0.6 A
• Unshielded	max. 600 m	• At signal "0" (leakage current)	max. 0.5 mA
• Shielded	max. 1000 m	Output delay (for resistive load)	
Voltages, Currents, Potentials		• At "0" to "1"	max. 100 μs
Rated load voltage L+	24 VDC	• At "1" to "0"	max. 500 μs
Total current of the outputs (per group)		Load resistor range	48 Ω to 4 kΩ
• Horizontal configuration		Lamp load	max. 5 W
Up to 40 °C	max. 4 A	Parallel connection of 2 outputs	
Up to 60 °C	max. 3 A	• For redundant triggering of a load	Possible (only outputs of the same group)
• Vertical configuration		• To increase performance	Not possible
Up to 40 °C	max. 2 A	Triggering a digital input	Possible
Isolation		Switch rate	
• Between channels and backplane bus	Yes	• For resistive load	max. 100 Hz
• Between the channels In groups of	Yes 8	• Inductive loads according to IEC 947-5-1, DC 13	max. 0.5 Hz
Permitted potential difference		• For lamp load	max. 10 Hz
• Between the different circuits	75 VDC / 60 VAC	Limit (internal) of the inductive circuit interruption voltage up	L + (–53 V), typ.
Insulation tested with	500 VDC	Short-circuit protection of the output	Yes, electronic
Current consumption		• Threshold on	1 A, typ.
• From the backplane bus	max. 110 mA		
• From load voltage L + (without load)	max. 160 mA		
Power dissipation of the module	typ. 6.6 W		
Status, Interrupts, Diagnostics			
Status display	Green LED per channel		
Interrupts	None		
Diagnostic functions	None		

3.17 Digital Output Module SM 322; DO 32 × 120 VAC/1.0 A; (6ES7 322-1EL00-0AA0)

Order number

6ES7 322-1EL00-0AA0

Characteristics

The SM 322; DO 32 × 120 VAC/1.0 A features the following characteristics:

- 32 outputs, fused and isolated in groups of 8
- 1.0 A output current
- 120 VAC rated load voltage
- Blown fuse indicator for each group
- Suitable for AC solenoids, contactors, starters, fractional horsepower motors and indicator lights
- Group error display

Terminal assignment and block diagram of the SM 322; DO 32 × 120 VAC/1.0 A

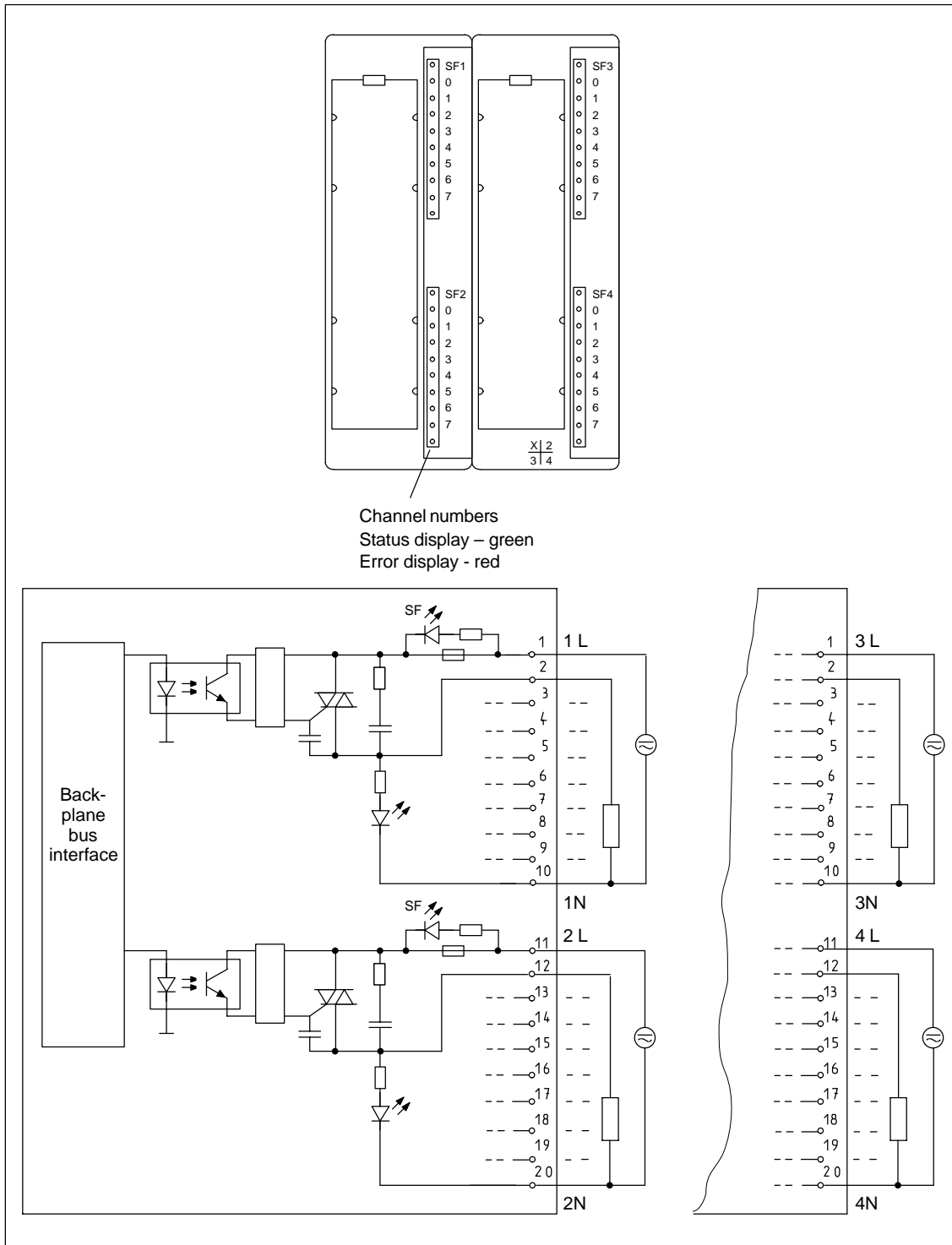

Figure 3-16 Module View and Block Diagram of the SM 322; DO 32 × 120 VAC/1.0 A

Terminal assignment

The following figure shows the assignment of the channels to the addresses.

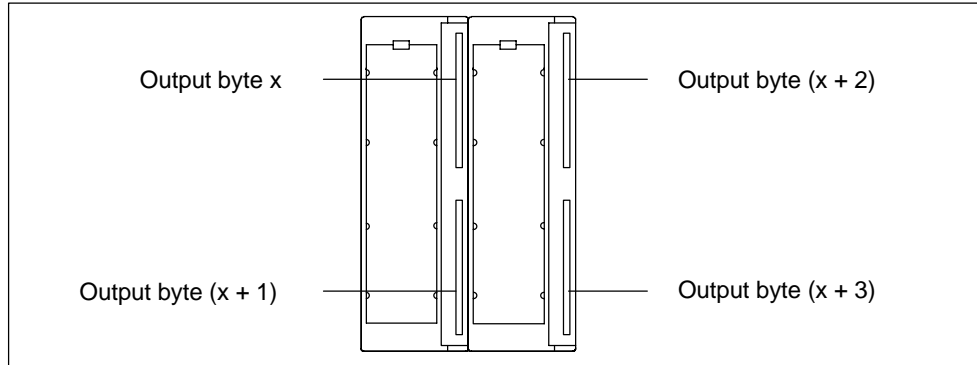

Figure 3-17 Terminal Assignment of the SM 322; DO 32 × 120 VAC/1.0 A

Technical specifications of the SM 322; DO 32 × 120 VAC/1.0 A

Dimensions and Weight		Data for Selecting an Actuator	
Dimensions W × H × D (in millimeters)	80 × 125 × 117	Output voltage	
Weight	Approx. 500 g	• At signal "1"	min. L1 (-1.5 V)
Data for Specific Module		Output current	
Supports clocked operation	No	• At "1" signal	
Number of outputs	32	Rated value	1 A
Length of cable		Permitted range	10 mA to 1 A
• Unshielded	max. 600 m	Permitted current surge (per group)	10 A (for 2 AC scan cycles)
• Shielded	max. 1000 m	• At "0" signal	max. 3 mA
Voltages, Currents, Potentials		Leakage current	
Rated load voltage L1	120 VAC	Output delay (for resistive load)	
• Permitted frequency range	47 Hz to 63 Hz	• At "0" to "1"	3 ms
Total current of the outputs (per group)		• At "1" to "0"	½ AC scan cycle
• Horizontal configuration Up to 60°C	max. 3 A	Zero cross inhibit voltage	Non-zero cross outputs
• Vertical configuration Up to 40°C	max. 4 A	Size of the motor starter	max. size 4 to NEMA
Isolation		Lamp load	max. 25 W
• Between channels and backplane bus	Yes	Parallel connection of 2 outputs	
• Between the channels	Yes	• For redundant actuation of a load	Possible (only outputs of the same group)
In groups of	8	• To increase performance	Not possible
Permitted potential difference		Actuation of digital input	Possible
• Between M _{internal} and the outputs	120 VAC	Switch rate	
• Between the outputs of the different groups	250 VAC	• For resistive load	max. 10 Hz
Insulation tested with	2500 VDC	• Inductive loads, according to IEC 947-5-1, AC 15	max. 0.5 Hz
Current consumption		• For lamp load	1 Hz
• From the backplane bus	max. 100 mA	Short-circuit protection of the output	No
• From load voltage L1 (without load)	max. 275 mA		
Power dissipation of the module	typ. max. 25 W		
Status, Interrupts, Diagnostics			
Status display	Green LED per channel		
Interrupts	No		
Diagnostic functions	Yes		
• Group error display	Red LED (SF)		

3.18 Digital Output Module SM 322; DO 16 × 24 VDC/ 0.5 A; (6ES7 322-1BHx1-0AA0)

Order number: "Standard module"

6ES7 322-1BH01-0AA0

Order number: "SIMATIC Outdoor module"

6ES7 322-1BH81-0AA0

Characteristics

The digital output module SM 322; DO 16 × 24 VDC/0.5 A has the following salient features:

- 16 outputs, isolated in groups of 8
- 0.5 A output current
- 24 VDC rated load voltage
- Suitable for solenoid valves, DC contactors and indicator lights

Using the module with high-speed counters

Please take note of the following information on the use of the module in connection with high-speed counters:

Note

When connecting the 24 V power supply via a mechanical contact, the outputs of the SM 322; DO 16 × 24 VDC/0.5 A carry a "1" signal for approximately 50 μs for reasons associated with the circuitry.

Terminal assignment and block diagram of the SM 322; DO 16 × 24 VDC/0.5 A

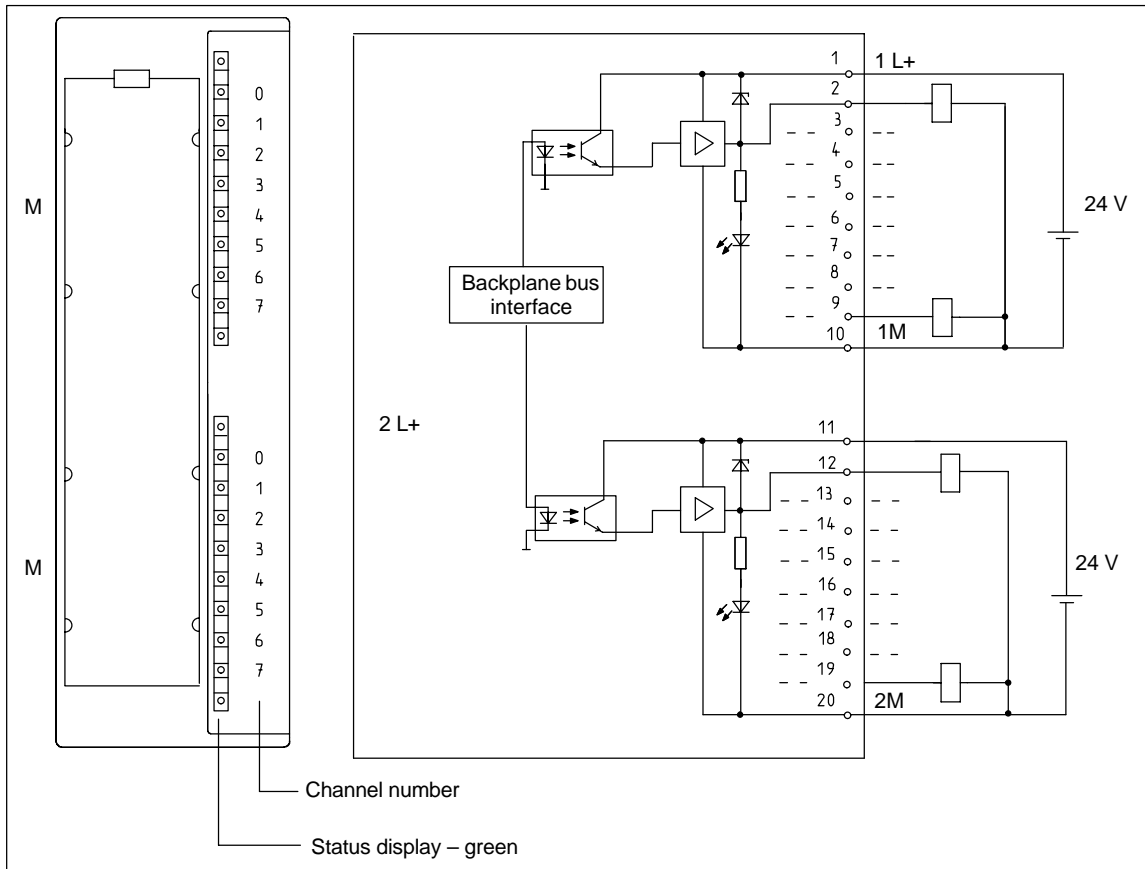

Figure 3-18 Module View and Block Diagram of the SM 322; DO 16 x 24 VDC/0.5 A

Technical specifications of the SM 322; DO 16 × 24 VDC/0.5 A

Dimensions and Weight		Data for Selecting an Actuator	
Dimensions W × H × D (in millimeters)	40 × 125 × 117	Output voltage	
Weight	Approx. 190 g	• At signal "1"	min. L + (–0.8 V)
Data for Specific Module		Output current	
Supports clocked operation	No	• At signal "1"	
Number of outputs	16	Rated value	0.5 A
Length of cable		Permitted range	5 mA to 0.6 A
• Unshielded	max. 600 m	• At signal "0" (leakage current)	max. 0.5 mA
• Shielded	max. 1000 m	Output delay (for resistive load)	
Voltages, Currents, Potentials		• At "0" to "1"	max. 100 µs
Rated load voltage L+	24 VDC	• At "1" to "0"	max. 500 µs
Total current of the outputs (per group)		Load resistor range	48 Ω to 4 kΩ
• Horizontal configuration		Lamp load	max. 5 W
Up to 40 °C	max. 4 A	Parallel connection of 2 outputs	
Up to 60 °C	max. 3 A	• For redundant triggering of a load	Possible (only outputs of the same group)
• Vertical configuration		• To increase performance	Not possible
Up to 40 °C	max. 2 A	Triggering a digital input	Possible
Isolation		Switch rate	
• Between channels and backplane bus	Yes	• For resistive load	max. 100 Hz
• Between the channels In groups of	Yes 8	• Inductive loads according to IEC 947-5-1, DC 13	max. 0.5 Hz
Permitted potential difference		• For lamp load	max. 10 Hz
• Between the different circuits	75 VDC / 60 VAC	Limit (internal) of the inductive circuit interruption voltage up	L + (–53 V), typ.
Insulation tested with	500 VDC	Short-circuit protection of the output	Yes, electronic
Current consumption		• Threshold on	1 A, typ.
• From the backplane bus	max. 80 mA		
• From load voltage L+ (without load)	max. 80 mA		
Power dissipation of the module	typ. 4.9 W		
Status, Interrupts, Diagnostics			
Status display	Green LED per channel		
Interrupts	None		
Diagnostic functions	None		

3.19 Digital Output Module SM 322; DO 16 × 24 VDC/0.5 A High Speed; (6ES7 322-1BH10-0AA0)

Order number:

6ES7 322-1BH10-0AA0

Characteristics

The SM 322; DO 16 × 24 VDC/0.5 A High Speed has the following salient features:

- 16 outputs, isolated in groups of 8
- 0.5 A output current
- 24 VDC rated load voltage
- Suitable for solenoid valves, DC contactors and indicator lights
- Supports clocked operation

Using the module with high-speed counters

Please take note of the following information on the use of the module in connection with high-speed counters:

Note

When connecting the 24 V power supply via a mechanical contact, the outputs of the SM 322; DO 16 × 24 VDC/0.5 A High Speed carry a "1" signal for approximately 50 μs for reasons associated with the circuitry.

Terminal assignment and block diagram of the SM 322; DO 16 × 24 VDC/0.5 A High Speed

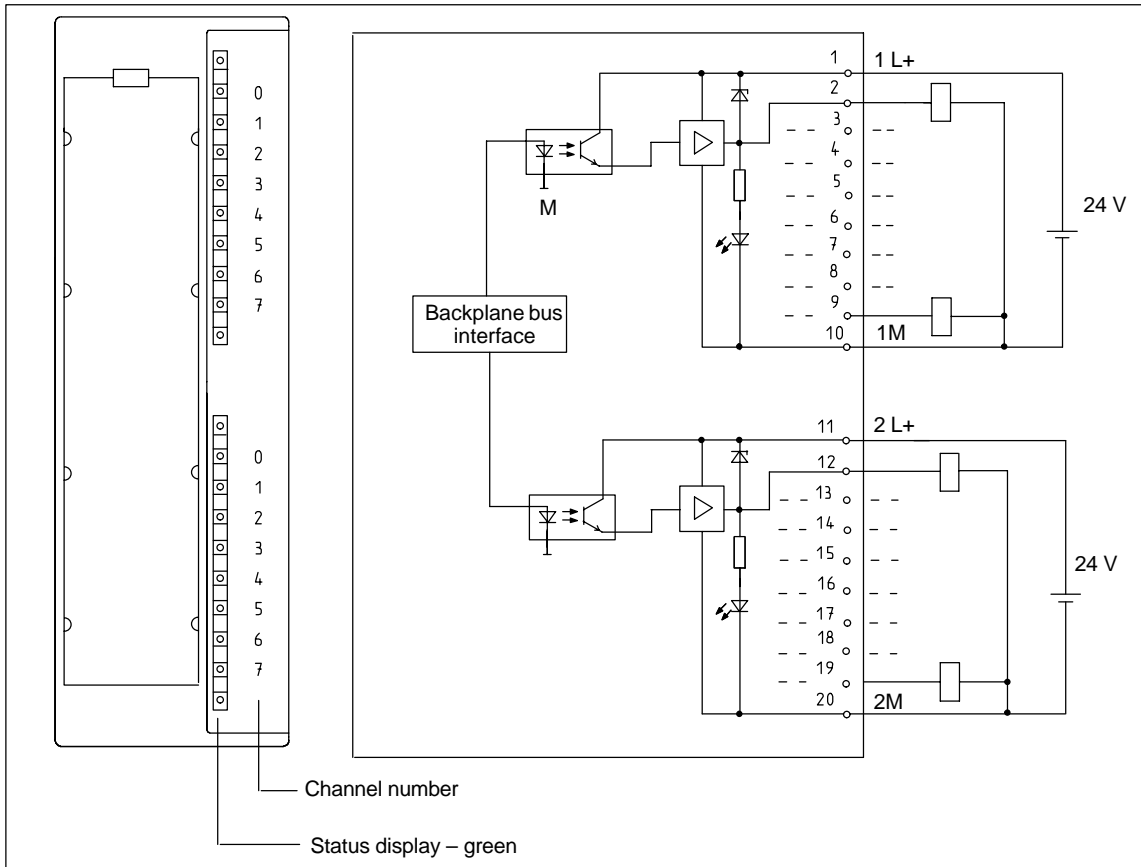

Figure 3-19 Module View and Block Diagram of the SM 322; DO 16 x 24 VDC/0.5 A High Speed

Technical specifications of the SM 322; DO 16 × 24 VDC/0.5 A High Speed

Dimensions and Weight		Data for Selecting an Actuator	
Dimensions W × H × D (in millimeters)	40 × 125 × 117	Output voltage	
Weight	Approx. 200 g	• At signal "1"	min. L + (−0.8 V)
Data for Specific Module		Output current	
Supports clocked operation	Yes	• At signal "1"	
Number of outputs	16	Rated value	0.5 A
Length of cable		Permitted range	5 mA to 0.6 A
• Unshielded	max. 600 m	• At signal "0" (leakage current)	max. 0.5 mA
• Shielded	max. 1000 m	Output delay (for resistive load)	
Voltages, Currents, Potentials		• At "0" to "1"	max. 100 μs
Rated load voltage L+	24 VDC	• At "1" to "0"	max. 200 μs
Total current of the outputs (per group)		Internal module run time between the backplane bus and the output driver input	
• Horizontal configuration		• At "0" to "1"	0.1 μs to 20 μs
Up to 40 °C	max. 4 A	• At "1" to "0"	0.1 μs to 20 μs
Up to 60 °C	max. 3 A	Load resistor range	48 Ω to 4 kΩ
• Vertical configuration		Lamp load	max. 5 W
Up to 40 °C	max. 2 A	Parallel connection of 2 outputs	
Isolation		• For redundant triggering of a load	Possible (only outputs of the same group)
• Between channels and backplane bus	Yes	• To increase performance	Not possible
• Between the channels in groups of	Yes 8	Triggering a digital input	Possible
Permitted potential difference		Switch rate	
• Between the different circuits	75 VDC / 60 VAC	• For resistive load	max. 1000 Hz
Insulation tested with	500 VDC	• Inductive loads according to IEC 947-5-1, DC 13	max. 0.5 Hz
Current consumption		• For lamp load	max. 10 Hz
• From the backplane bus	max. 70 mA	Limit (internal) of the inductive circuit interruption voltage up	L + (−53 V), typ.
• From load voltage L + (without load)	max. 110 mA	Short-circuit protection of the output	Yes, electronic
Power dissipation of the module	typ. 5 W	• Threshold on	1 A, typ.
Status, Interrupts, Diagnostics			
Status display	Green LED per channel		
Interrupts	None		
Diagnostic functions	None		

3.20 Digital Output Module SM 322; DO 16 × 24/48 VUC; (6ES7 322-5GH00-0AB0)

Order number

6ES7 322-5GH00-0AB0

Characteristics

Digital output module SM 322; DO 16×UC24/48 V has the following features:

- 16 individually isolated static relay outputs
- Electrical isolation between channels of 120 V
- Switch characteristics: $R_{DS\ ON}$ is typically 0.25 ohms and $R_{DS\ OFF}$ is typically greater than 100 G-ohms
- Designed for load voltages up to 48 V AC or DC and there is no minimum load voltage
- Designed for output loads up to 0.5 A and there is no minimum load current
- Outputs are fully independent and can be connected in any required configuration
- Substitute values or "Hold last values" can be programmed for the outputs
- The module has diagnostics for parameterization errors and external loss of voltage
- Suitable for AC solenoids, contact makers, motor starters, fractional horsepower motors and indicator lights

Terminal assignment and block diagram of the SM 322; DO 16 × 24/48 VUC

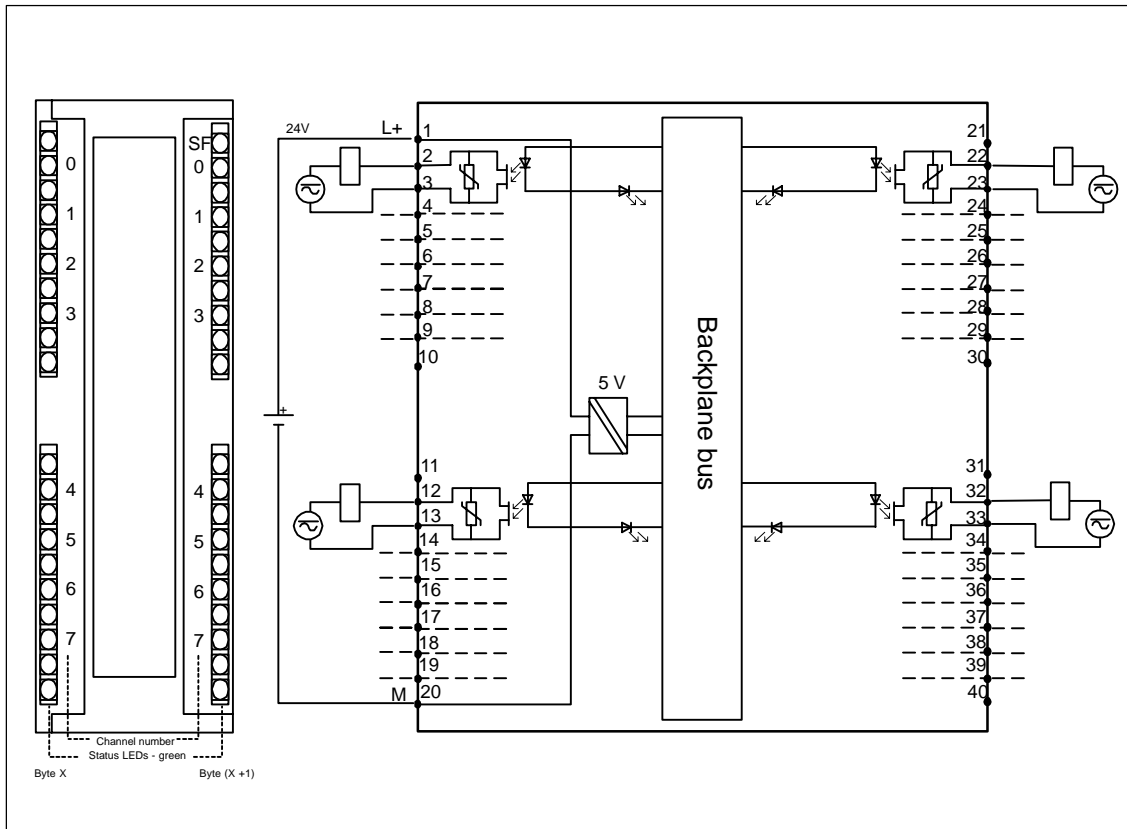

Figure 3-20 Module View and Block Diagram of SM 322; DO 16×24/48 VUC

Technical specifications of the SM 322; DO 16 × 24/48 VUC

Dimensions and Weight		Insulation tested with	
Dimensions W × H × D (in millimeters)	40 × 125 × 117	• Between channels and backplane bus	1500 VAC
Weight	Approx. 260 g	• Between channels and power supply of the electronics	1500 VAC
Data for Specific Module		• Between the outputs of the different groups	1500 VAC
Supports clocked operation	No	Current consumption	
Number of outputs	16	• From the backplane bus	max. 100 mA
Length of cable		• From supply voltage L+	max. 200 mA
• Unshielded	max. 600 m	Power dissipation of the module	
• Shielded	max. 1000 m	typ. 2.8 W	
Voltages, Currents, Potentials		Status, Interrupts, Diagnostics	
Power rated voltage of the electronics L+	24 VDC	Status display	Green LEDs per channel
• Reverse polarity protection	Yes	Diagnostic functions	
• Power failure jumpering	min. 5 ms	• Group error display	Red LED (SF)
Total current of the outputs (per group)		Interrupts	
• Horizontal configuration Up to 60° C	max. 0.5 A	• Diagnostic Interrupt	Parameters can be assigned
• All other mounting positions Up to 40° C	max. 0.5 A	• Diagnostics information read-out	Possible
Data for Selecting an Actuator			
Total current of the outputs (per module)		Output voltage	
• Horizontal configuration Up to 60° C	max. 8 A	• At signal "1"	min. L+ (-0.25 V)
• All other mounting positions Up to 40° C	max. 8 A	Output current	
Isolation		• At signal "1" rated value	0.5 A
• Between channels and backplane bus	Yes	permissible surge current (per group)	max. 1.5 A (max. 50 ms)
• Between channels and power supply of the electronics	Yes	• For "0" signal (leakage current)	max. 10 uA
• Between channels In groups of	Yes 1	Output delay (for resistive load)	
Permitted potential difference		• At "0" to "1"	max. 6 ms
• Between channels and backplane bus	170 VDC, 120 VAC	• At "1" to "0"	max. 3 ms
• Between channels and power supply of the electronics	170 VDC, 120 VAC	External fuse for relay outputs	Fuse, I ² t: 1 A ² s, quick-acting*
• Between the outputs of the different groups	170 VDC, 120 VAC	Lamp load	max. 2.5 W
		Contact circuit (internal) parallel switching of 2 outputs	Varistor, 85 V
		• For redundant triggering of a load	Possible
		• To increase performance	Not possible

Triggering a digital input	Possible	* Outputs must be protected by a 250 V quick-acting fuse (recommended fuses: Wickman 194-1100 1.1 A and Littelfuse 0217-800 V 800 mA). When mounted in a hazardous area in accordance with the National Electric Code (NEC), use only a suitable tool to remove the fuse if the module is not located in a potentially explosive atmosphere.
Switch rate		
• For resistive load	max. 10 Hz	
• Inductive loads according to IEC 947-5-1; DC 12 AC/12	max. 0.5 Hz	
• For lamp load	max. 0.5 Hz	

Parameters of digital output module SM 322 DO 16 × UC24/48 V

Parameterization

Table 3-14 and Table 3-15 show the data record numbers for static and dynamic parameters.

Table 3-14 Data record no. 0 (static parameters):

Parameter	Comments
Enable diagnostics	Enabling an interrupt when the module fails because of an operation code error, a hardware fault or a voltage error.

Table 3-15 Data record no. 1 (dynamic parameters):

Parameter	Comments
Behavior on CPU STOP	
Hold last value	
Substitute value output	
Substitute value	
Substitute value	Each bit corresponds to an output.

This module supports failure state/substitute value outputs when the CPU changes from RUN to STOP.

Status display

Each output of this module has a green LED to indicate the status of the relay. There is also a red LED (SF) that indicates the diagnostics status of the module.

Diagnostics, troubleshooting

Diagnostic data is assigned in accordance with the following technical specifications.

In the additional interrupt information, the four system diagnostics data bytes can be read as data record 0 or in the first 4 bytes of data record 1.

Structure of the data record

The structure of data record 1 is as specified in Table 3-16.

Table 3-16 Structure of the Data Record for SM 322 DO 16×UC 24/48 V

Data record 1 byte address	Available information	Contents
0..3	System-specific diagnostics data	4 Bytes
4	Channel type	72h
5	Diagnosis length per channel in bytes	0
6	Number of channels	16
7	Channel error vector	0 byte per channel
8..15	Channel-specific diagnostic data	0 byte per channel

Table 3-17 shows the system diagnostics for module SM 322; DO 16 × UC24/48 V.

Table 3-17 System Diagnostics for SM 322 DO 16×UC 24/48 V

System diagnosis byte 1:		Technical specification
D0:	Module error	Yes
D1:	Internal malfunction	Yes
D2:	External malfunction	Yes
D3:	Channel error	No
D4:	External auxiliary supply missing	Yes
D5:	Front connector missing	No
D6:	Module not parameterized.	Yes
D7:	Wrong parameters	Yes

Table 3-17 System Diagnostics for SM 322 DO 16×UC 24/48 V

System diagnosis byte 2:		
D0..D3	Module Type	1111
D4:	Channel information available	No
D5:	User information available	No
D6:	Diagnostic alarm from substitute	No
D7:	Spare	
System diagnosis byte 3:		
D0:	Memory module incorrect/missing	No
D1:	Communication error	No
D2:	RUN/STOP mode	No
D3:	Time monitoring triggered	Yes
D4:	Internal power failure	No
D5:	Battery 1 empty	No
D6:	Complete backup failure	No
System diagnosis byte 4:		
D7:	Spare	
D0:	Rack failure	No
D1:	Processor failure	Yes
D2:	EPROM error	Yes
D3:	RAM error	Yes
D4:	DAC error	No
D5:	Blown fuse	No
D6:	Hardware interrupt lost	No
D7:	Spare	
Channel-specific diagnosis byte		
D0:	Parameter setup error	No
D1:	Grounding error	No
D2:	Short-circuit to P	No
D3:	Short-circuit to M	No
D4:	Wire-break	No
D5:	Spare	
D6:	Auxiliary supply missing	No
D7:	Overtemperature	No

3.21 Digital Output Module SM 322; DO 16 × 120/230 VAC/1 A: (6ES7 322-1FH00-0AA0)

Order number

6ES7 322-1FH00-0AA0

Characteristics

Digital output module SM 322; DO 16 × 120/230 VAC/1 A has the following distinguishing characteristics:

- 16 outputs, fused and electrically isolated in groups of 8
- 1 A output current
- Rated load voltage 120/230 VAC
- Suitable for AC solenoids, contact makers, motor starters, fractional horsepower motors and indicator lights

Terminal assignment and block diagram of the SM 322 DO 16 × 120/230 VAC/1 A

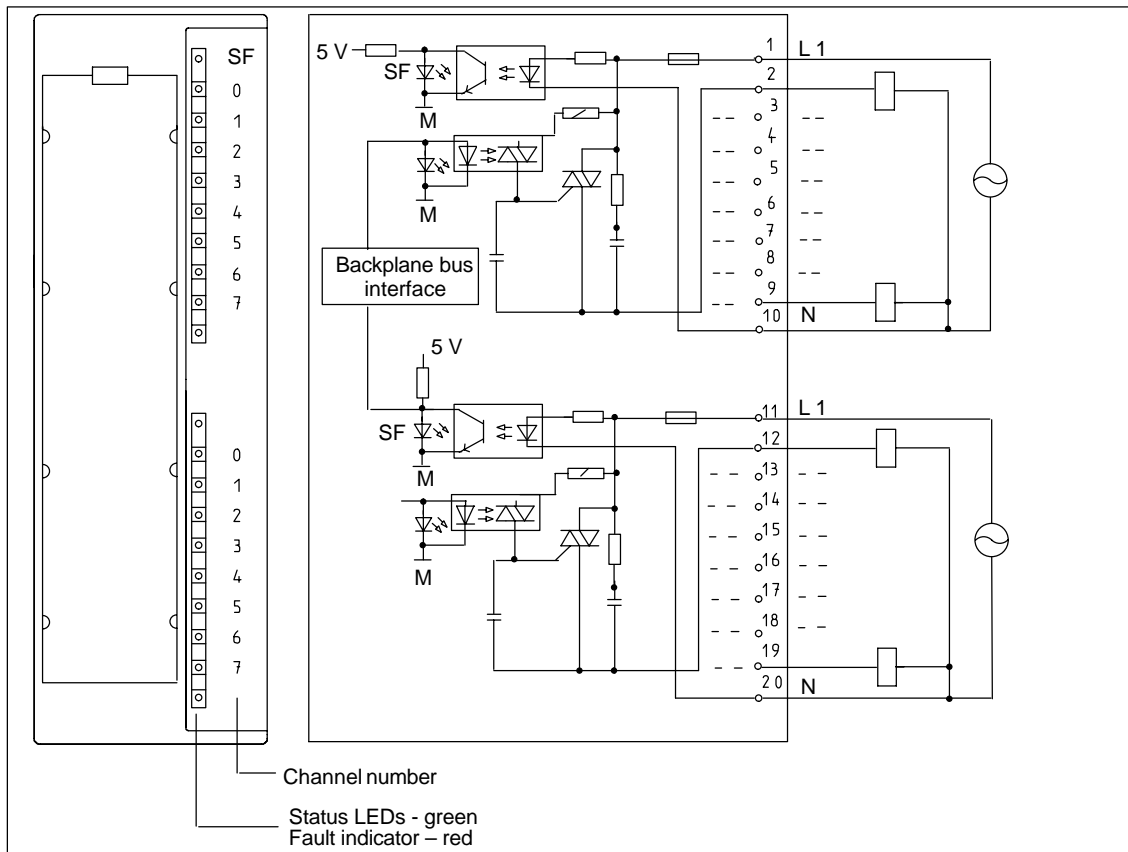

Figure 3-21 Module View and Block Diagram of the SM 322; DO 16 x 120/230 VAC/1 A

Dimensions and Weight		Data for Selecting an Actuator	
Dimensions W × H × D	40 × 125 × 117	Output voltage	
Weight	Approx. 275 g	• At signal "1"	min. L + (–0.8 V)
Data for Specific Module		Output current	
Supports clocked operation	No	• At signal "1"	
Number of outputs	16	Rated value	1 A
Length of cable		Permitted range for 0° C to 40° C	10 mA to 1 A
• Unshielded	max. 600 m	Permitted range for 0° C to 60° C	10 mA to 0.5 A
• Shielded	max. 1000 m	Permitted surge current (per group)	max. 20 A (with 2 half-waves)
Voltages, Currents, Potentials		• At signal "0" (leakage current)	max. 2 mA
Rated load voltage L1	120/230 VAC	Inhibit voltage	max. 60 V
All load voltages must be of the same phase		Zero cross inhibit voltage	
Total current of the outputs (per group)		Size of the motor starter	max. size 4 to NEMA
• Horizontal configuration		Lamp load	max. 50 W
Up to 40 °C	max. 4 A	Connecting two outputs in parallel	
Up to 60 °C	max. 2 A	• For redundant triggering of a load	Possible (only outputs of the same group)
• Vertical configuration		• To increase performance	No
Up to 40 °C	max. 2 A	Triggering a digital input	No
Isolation		Switch rate	
• Between channels and backplane bus	Yes	• For resistive load	max. 10 Hz
• Between channels	Yes	• Inductive loads, according to IEC 947-5-1, AC 15	max. 0.5 Hz
In groups of	8	• For lamp load	max. 1 Hz
Permitted potential difference		Short-circuit protection of output	Fuse 8 A, 250 V; per group
• Between M _{internal} and the outputs	500 VAC	• Min. current required for fuse to blow	min. 40 A
• Between the outputs of the different groups	230 VAC	• Max. response time	max. 300 ms
Insulation tested with	4000 VDC	Replacement fuses	8 A fuse, quick-acting
Current consumption		• Wickman	19 194-8 A
• From the backplane bus	max. 200 mA	• Schurter	SP001.1014
• From load voltage L+ (without load)	max. 2 mA	• Littlefuse	217.008
Power dissipation of the module	typ. 8.6 W	Fuse carrier	
Status, Interrupts, Diagnostics		• Wickman	19 653
Status display	Green LED per channel		
Interrupts			
• Diagnostic Interrupt	No		
Diagnostic functions			
• Group error display	Red LED (SF) (fuse or no L1/N)		

3.22 Digital Output Module SM 322; DO 8 × 24 VDC/2 A; (6ES7 322-1BF01-0AA0)

Order number

6ES7 322-1BF01-0AA0

Characteristics

The digital output module SM 322; DO 8 × 24 VDC/2 A has the following salient features.

- 8 outputs, isolated in groups of 4
- 2 A output current
- 24 VDC rated load voltage
- Suitable for solenoid valves, DC contactors and indicator lights

Using the module with high-speed counters

Please take note of the following information on the use of the module in connection with high-speed counters:

Note

When connecting the 24 V power supply via a mechanical contact, the outputs of the SM 322; DO 8 × 24 VDC/2 A carry a "1" signal for approximately 50 μs for reasons associated with the circuitry.

Module View and Block Diagram of the SM 322; DO 8 × 24 VDC/2 A

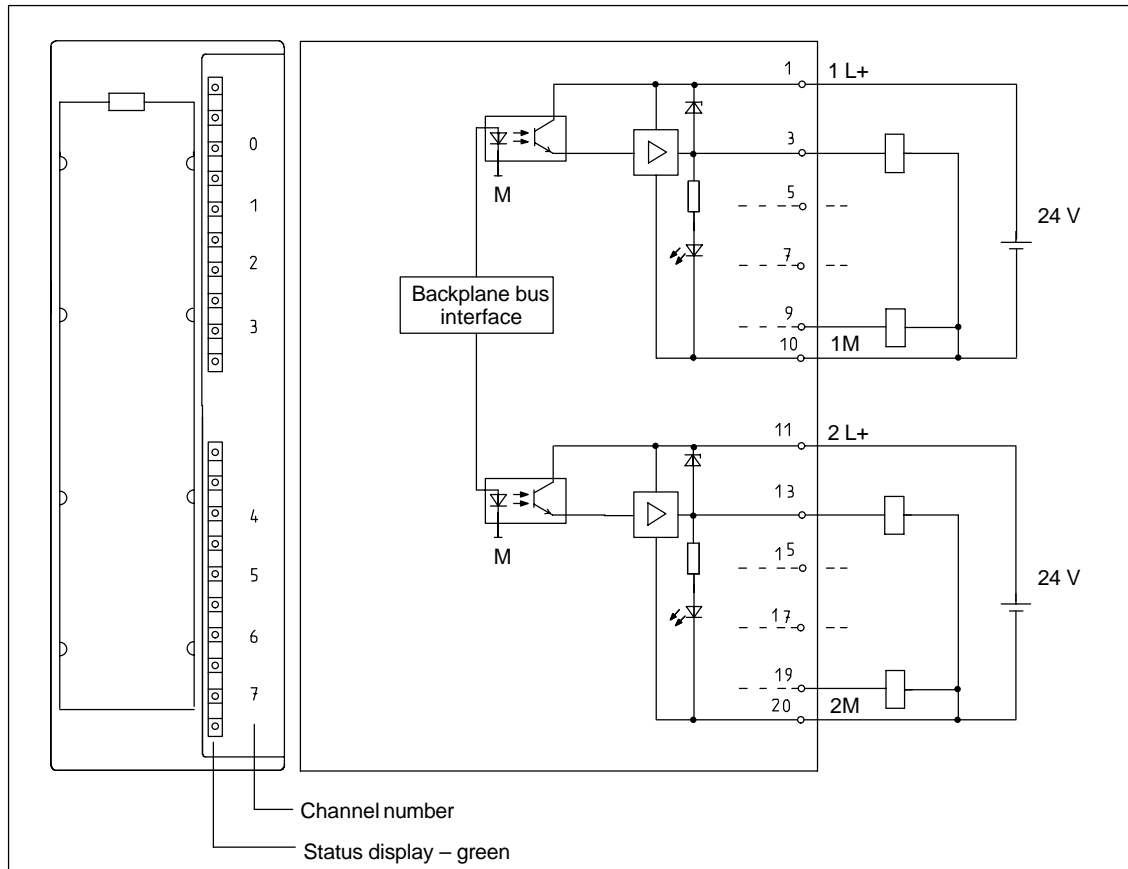

Figure 3-22 Module View and Block Diagram of Digital Output Module SM 322; DO 8 × 24 VDC/2 A

Technical specifications of the SM 322; DO 8 × 24 VDC/2 A

Dimensions and Weight		Data for Selecting an Actuator	
Dimensions W × H × D (in millimeters)	40 × 125 × 117	Output voltage	
Weight	Approx. 190 g	• At signal "1"	min. L + -0.8 V
Data for Specific Module		Output current	
Supports clocked operation	No	• At signal "1"	
Number of outputs	8	Rated value	2 A
Length of cable		Permitted range	5 mA to 2.4 A
• Unshielded	max. 600 m	• At signal "0" (leakage current)	max. 0.5 mA
• Shielded	max. 1000 m	Output delay (for resistive load)	
Voltages, Currents, Potentials		• At "0" to "1"	max. 100 μs
Rated load voltage L+	24 VDC	• At "1" to "0"	max. 500 μs
Total current of the outputs (per group)		Load resistor range	12 Ω to 4 kΩ
• Horizontal configuration Up to 60 °C	max. 4 A	Lamp load	max. 10 W
• Vertical configuration Up to 40 °C	max. 4 A	Parallel connection of 2 outputs	
Isolation		• For redundant triggering of a load	Possible (only outputs of the same group)
• Between channels and backplane bus	Yes	• To increase performance	Not possible
• Between the channels In groups of	Yes 4	Triggering a digital input	Possible
Permitted potential difference		Switch rate	
• Between the different circuits	75 VDC / 60 VAC	• For resistive load	max. 100 Hz
Insulation tested with	500 VDC	• Inductive loads according to IEC 947-5-1, DC 13	max. 0.5 Hz
Current consumption		• For lamp load	max. 10 Hz
• From the backplane bus	max. 40 mA	Limit (internal) of the inductive circuit interruption voltage up	typ. L + (-48 V)
• From load voltage L+ (without load)	max. 60 mA	Short-circuit protection of the output	Yes, electronic
Power dissipation of the module	typ. 6.8 W	• Threshold on	typ. 3 A
Status, Interrupts, Diagnostics			
Status display	Green LED per channel		
Interrupts	None		
Diagnostic functions	None		

3.23 Digital Output Module SM 322; DO 8 × 24 VDC/ 0.5 A; with Diagnostic Interrupt; (6ES7 322-8BFx0-0AB0)

Order number: "Standard module"

6ES7 322-8BF00-0AB0

Order number: "SIMATIC Outdoor module"

6ES7 322-8BF80-0AB0

Characteristics

The digital output module SM 322; DO × 24 VDC/0.5 A has the following salient features:

- 8 outputs, isolated in groups of 8
- 0.5 A output current
- 24 VDC rated load voltage
- Suitable for solenoid valves, DC contactors and indicator lights
- 2 terminals per output
 - Output without series diode
 - Output with series diode (for redundant load control)
- Group error display
- Channel-specific status and error LEDs
- Programmable diagnostics
- Programmable diagnostic interrupt
- Programmable substitute value output

Terminal assignment and block diagram of the SM 322; DO 8 × 24 VDC/0.5 A

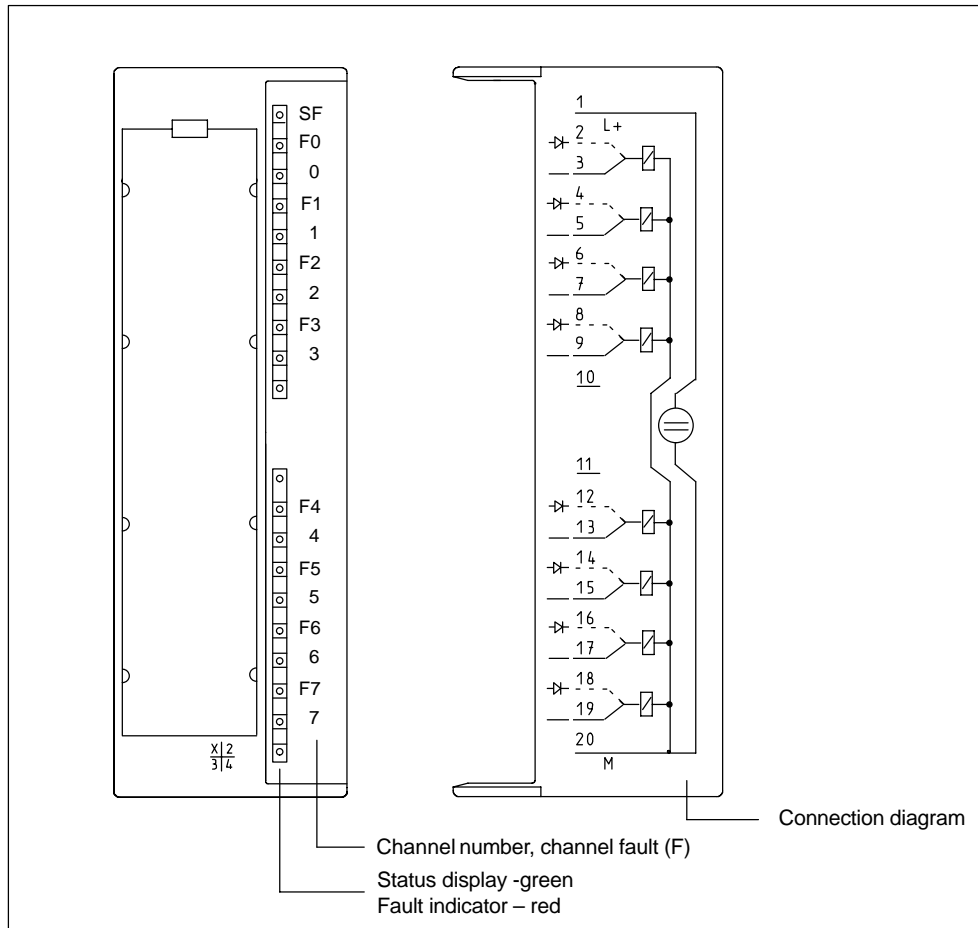

Figure 3-23 Module View of the SM 322; DO 8 × 24 V DC/0.5 A

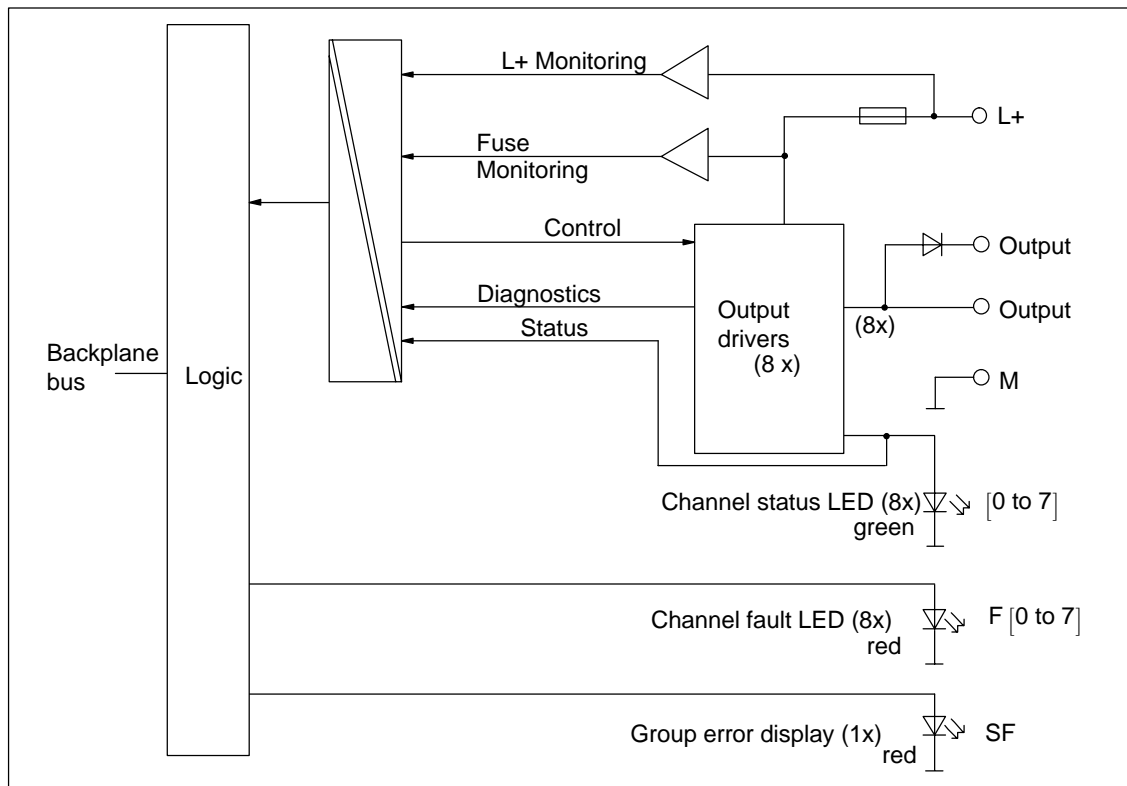

Figure 3-24 Block Diagram of the SM 322; DO 8 × DC 24 V/0.5 A

Redundant control of a load

The output with series diode can be used for redundant control of a load. Redundant control is possible from two different signal modules without external circuitry. Both modules must have the same reference potential, M.

Note

If the output with series diode is used, external short-circuits to L+ cannot be detected.

Technical specifications of the SM 322; DO 8 × 24 VDC/0.5 A

Dimensions and Weight		Status, Interrupts, Diagnostics	
Dimensions W × H × D (in millimeters)	40 × 125 × 117	Status display	Green LED per channel
Weight	Approx. 210 g	Interrupts	
Data for Specific Module		• Diagnostic Interrupt	Parameters can be assigned
Supports clocked operation	No	Diagnostic functions	Parameters can be assigned
Number of outputs	8	• Group error display	Red LED (SF)
Length of cable		• Channel error display (F)	Red LED (F) per channel
• Unshielded	max. 600 m	• Diagnostics information readable	Possible
• Shielded	max. 1000 m		
Voltages, Currents, Potentials			
Rated load voltage L+	24 VDC		
Total current of the outputs (per group) without series diode			
• Horizontal configuration			
Up to 40 °C	max. 4 A		
Up to 60 °C	max. 3 A		
• Vertical configuration			
Up to 40 °C	max. 4 A		
Total current of the outputs (per group) with series diode			
• Horizontal configuration			
Up to 40 °C	max. 3 A		
Up to 60 °C	max. 2 A		
• Vertical configuration			
Up to 40 °C	max. 3 A		
Isolation			
• Between channels and backplane bus	Yes		
Permitted potential difference			
• Between the different circuits	75 VDC / 60 VAC		
Insulation tested with	500 VDC		
Current consumption			
• From the backplane bus	max. 70 mA		
• From load voltage L+ (without load)	max. 90 mA		
Power dissipation of the module	typ. 5 W		

Data for Selecting an Actuator			
Output voltage		• To increase performance	Not possible
• At signal "1"		Triggering a digital input	Possible
Without series diode	min. L + (-0.8 V)		1 binary input according to IEC 61131, Type 2;
With series diode	min. L + (-1.6 V)		Type 1 with disabled open-circuit monitoring
Output current		Switch rate	
• At signal "1"		• For resistive load	max. 100 Hz
Rated value	0.5 A	• Inductive load according to IEC 947-5-1, 13 DC	max. 2 Hz
Permitted range	10 mA to 0.6 A ¹⁾	• For lamp load	max. 10 Hz
• At signal "0" (leakage current)	max. 0.5 mA	Limit (internal) of the inductive circuit interruption voltage up	typ. L + (-45 V)
Output delay (for resistive load)		Short-circuit protection of the output	Yes, electronic
• At "0" to "1"	max. 180 μs	• Threshold on	typ. 0.75 A to 1.5 A
• At "1" to "0"	max. 245 μs		
Load resistor range	48 Ω to 3 kΩ		
Lamp load	max. 5 W		
Parallel connection of 2 outputs			
• For redundant actuation of a load	Output with series diode only, must have the same reference potential		

1) 5 mA to 0.6 A with disabled open-circuit monitoring

3.23.1 Assigning Parameters to the SM 322; DO 8 × 24 VDC/0.5 A

Parameterization

You will find a description of the general procedure for assigning parameters to digital modules in Section 3.3.

Parameters of the SM 322; DO 8 × 24 VDC/0.5 A

You will find an overview of the parameters that you can set and their default settings for the SM 322; DO 8 × 24 VDC/0.5 A in the table below.

The default settings apply if you have not performed parameter assignment in *STEP 7*.

Table 3-18 Parameters of the SM 322; DO 8 × 24 VDC/0.5 A

Parameter	Value Range	Default Settings	Parameter Type	Scope
Enable				
• Diagnostic interrupt	Yes/no	No	Dynamic	Module
Behavior on CPU STOP	Apply substitute value (EWS) Hold last value (LWH)	EWS		
Diagnostics				
• Wire-break	Yes/no	No	Static	Channel
• No load voltage L+	Yes/no	No		
• Short-circuit to M	Yes/no	No		
• Short-circuit to L+	Yes/no	No		
Apply substitute value "1"	Yes/no	No	Dynamic	Channel

3.23.2 Behavior and Diagnostics of the SM 322; DO 8 × 24 VDC/0.5 A

Effect of operating and mode supply voltage on the output values

The output values of the SM 322; DO 8 × 24 VDC/0.5 A depend on the operating mode of the CPU and on the supply voltage of the module.

Table 3-19 Dependence of the Output Values on the Operating Mode of the CPU and on the Supply Voltage L+ of the SM 322; DO 8 × 24 VDC/0.5 A.

CPU Operating State		Power Supply L+ to Digital Module	Output Value of Digital Module
POWER ON	RUN	L+ exists	CPU value
		L+ missing	0 signal
	STOP	L+ exists	Substitute value/last value (0 signal preset)
		L+ missing	0 signal
POWER OFF	–	L+ exists	0 signal
		L+ missing	0 signal

Behavior upon failure of the supply voltage

Failure of the supply voltage of the SM 322; DO 8 × 24 VDC/0.5 A is always indicated by the SF LED on the module. Furthermore, this information is made available on the module (entry in diagnosis).

Triggering of the diagnostic interrupt depends on the parameter assignment (see Section 3.23.3).

Diagnostic messages of the SM 322; DO 8 × 24 VDC/0.5 A

The following table provides an overview of the diagnostic messages of the SM 322; DO 8 × 24 VDC/0.5 A.

Table 3-20 Diagnostic Messages of the SM 322; DO 8 × 24 VDC/0.5 A

Diagnosics Message	LED	Scope of the Diagnostics	Parameters can be Assigned
Wire-break	SF	Channel	Yes
Load voltage missing	SF	Channel	Yes
Short-circuit to M	SF	Channel	Yes
Short-circuit to L+	SF	Channel	Yes
External auxiliary supply missing	SF	Module	No
Internal auxiliary power missing	SF	Module	No
Fuse blown	SF	Module	No
Watchdog timeout	SF	Module	No
EPROM error	SF	Module	No
RAM error	SF	Module	No

* Open-circuit detection is performed at a current < 1 mA.
When suitably parameterized, a wire-break results only in the SF LED and the corresponding channel error LED lighting up.

Note

A prerequisite for detecting the errors indicated by programmable diagnostic messages is that you have assigned parameters to the digital module accordingly in *STEP 7*.

Causes of error and remedial action

Table 3-21 Diagnostic Messages of the SM 322; DO 8 × 24 VDC/0.5 A, Causes of Error and Remedial Action

Diagnosics Message	Error Detection ...	Possible Error Cause	Remedy
Wire-break	Only with output to "1"	Open circuit between module and actuator	Close circuit
		Channel not connected (open)	Disable the "Diagnose Wire-break" parameter for the channel in <i>STEP 7</i>
No load voltage	Only with output to "1"	Defective output	Replace module
Short-circuit to M	Only with output to "1"	Overload of output	Eliminate overload
		Short-circuit of output to M	Eliminate short circuit
Short-circuit to L+	Always	Short-circuit at output to L+ of module supply	Eliminate short circuit
No external auxiliary voltage	Always	Power supply L+ to module missing	Feed supply L+
No internal auxiliary voltage	Always	Power supply L+ to module missing	Feed supply L+
		Fuse in module defective	Replace module
Fuse blown	Always	Fuse in module defective	Replace module
Watchdog tripped	Always	Temporary high electromagnetic interference	Eliminate interference
		Module defective	Replace module
EPROM error	Always	Temporary high electromagnetic interference	Eliminate interference and switch on/off power supply of CPU
		Module defective	Replace module
RAM error	Always	Temporary high electromagnetic interference	Eliminate interference and switch on/off power supply of CPU
		Module defective	Replace module

3.23.3 Interrupts of the SM 322; DO 8 × 24 VDC/0.5 A

Introduction

The SM 322; DO 8 × 24 VDC/0.5 A can trigger diagnostic interrupts.

The OBs and SFCs mentioned below can be found in the online Help for *STEP 7*, where they are described in greater detail.

Enabling interrupts

The interrupts are not preset – in other words, they are inhibited without appropriate parameter assignment. Assign parameters to the Interrupt Enable in *STEP 7* (refer to Section 3.23.1).

Diagnostic interrupt

If you have enabled diagnostic interrupts, then active error events (initial occurrence of the error) and departing error events (message after troubleshooting) are reported by means of an interrupt.

The CPU interrupts the execution of the user program and processes the diagnostic interrupt block (OB 82).

In the user program, you can call SFC 51 or SFC 59 in OB 82 to obtain more detailed diagnostic information from the module.

The diagnostic information is consistent until such time as OB 82 is exited. When OB 82 is exited, the diagnostic interrupt is acknowledged on the module.

3.24 Digital Output Module SM 322; DO 8 × 48-125 VDC/1.5 A; (6ES7 322-1CF80-0AA0)

Order number: "SIMATIC Outdoor module"

6ES7 322-1CF80-0AA0

Characteristics

The SM 322; DO 8 × 48-125 VDC/1.5 A features the following characteristics:

- 8 outputs, reverse polarity protection and isolated in groups of 4
- 1.5 A output current
- Rated load voltage 48 to 125 VDC
- Suitable for solenoid valves, DC contactors and indicator lights
- Group error display

Using the module with high-speed counters

Please take note of the following information on the use of the module in connection with high-speed counters:

Note

When connecting the power supply via a mechanical contact, the outputs of the SM 322; DO 8 × 48-125 VDC/1.5 A carry a "1" signal for approximately 50 μs for reasons associated with the circuitry.

Terminal assignment and block diagram of the SM 322; DO 8 × 48-125 VDC/1.5A

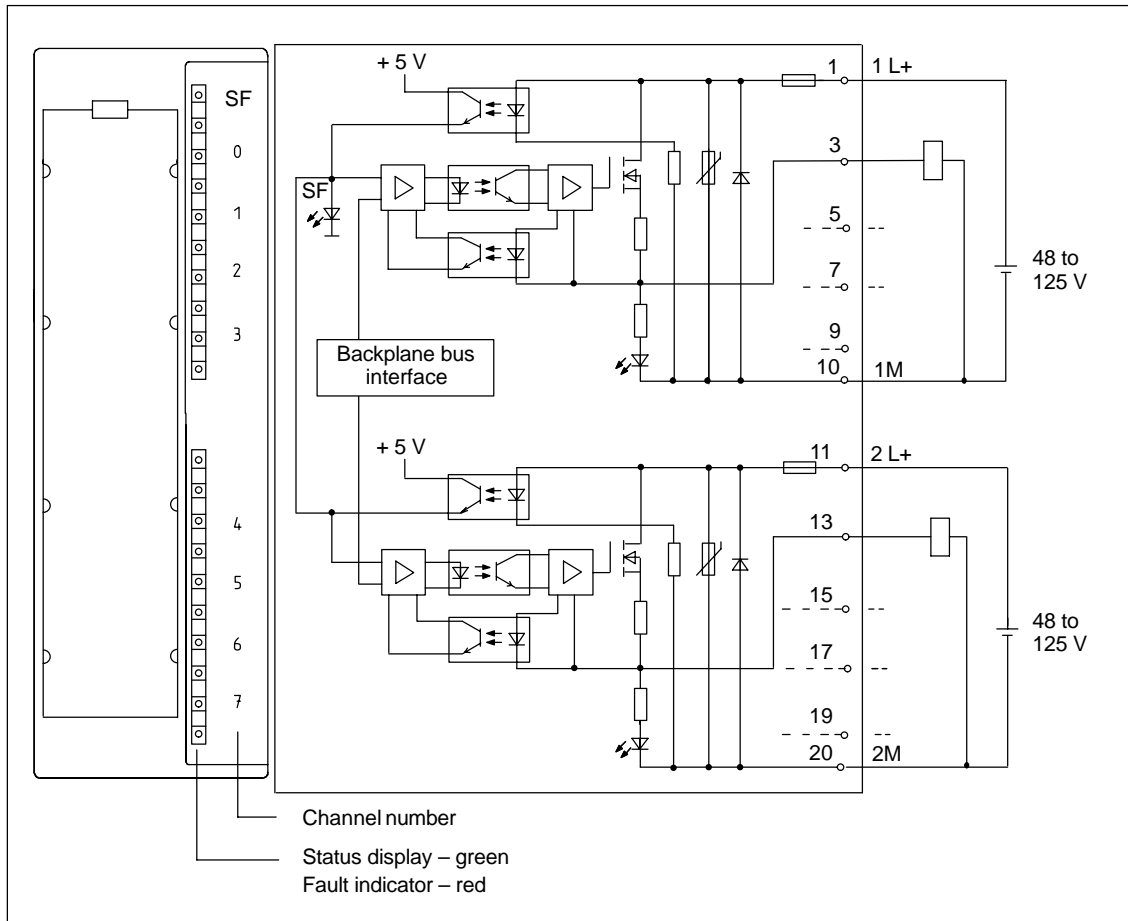

Figure 3-25 Module View and Block Diagram of the SM 322; DO 8 × 48-125 VDC/1.5 A

Technical specifications of the SM 322; DO 8 × 48-125 VDC/1.5 A

Dimensions and Weight		Data for Selecting an Actuator	
Dimensions W × H × D (in millimeters)	40 × 125 × 117	Output voltage	
Weight	Approx. 250 g	• At "1" signal	min. L + (-1.,2 V)
Data for Specific Module		Output current	
Supports clocked operation	No	• At "1" signal	
Number of outputs	8	Rated value	1.5 A
Length of cable		Permitted range	10 mA to 1.5 A
• Unshielded	max. 600 m	• Permitted surge current	max. 3 A for 10 ms
• Shielded	max. 1000 m	• For "0" signal (leakage current)	max. 0.5 mA
Voltages, Currents, Potentials		Output delay (for resistive load)	
Rated load voltage L+	48 VDC to 125 VDC	• At "0" to "1"	max. 2 ms
• Reverse polarity protection	Yes, by means of fuse ¹⁾	• At "1" to "0"	max. 15 ms
Total current of the outputs (per group)		Lamp load	max. 15 W at 48 V max. 40 W at 125 V
• Horizontal configuration		Parallel connection of 2 outputs	
Up to 40 °C	max. 6 A	• For redundant actuation of a load	Possible (only outputs of the same group)
Up to 50 °C	max. 4 A	• To increase performance	Not possible
Up to 60 °C	max. 3 A	Triggering a digital input	Possible
• Vertical configuration		Switch rate	
Up to 40 °C	max. 4 A	• For resistive load	max. 25 Hz
Isolation		• For inductive load	max. 0.5 Hz
• Between channels and backplane bus	Yes	• For lamp load	max. 10 Hz
• Between the channels	Yes	Limit (internal) of the in ductive circuit interruption voltage up	typ. M (-1V)
In groups of	4	Short-circuit protection of the output	Yes, electronic ³⁾
Permitted potential difference		• Threshold on	typ. 4.4 A
• Between the different circuits	146 VDC / 132 VAC	Replacement fuses	Fuse 6.,3 A/250 V, quick blow, 5 x 20 mm
Insulation tested with	1500 VAC	• Schurter	SP0001.1012
Current consumption		• Wickmann	194-1630-0
• From the backplane bus	max. 100 mA	Fuse carrier	
• From the load voltage L+ (no load)	max. 2 mA	• Schurter	FEK 0031.3562
Power dissipation of the module	typ. 7.2 W		
Status, Interrupts, Diagnostics			
Status display	Green LED per channel		
Interrupts	None		
Diagnostic functions			
• Group error display	Red LED (SF) ²⁾		

- 1) The fuses on this module are merely supplementary fuses. External overcurrent protection (suitable for branch circuits conforming to the local regulations for electrical engineering) is required in the supply cables of the load circuit.
- 2) Potential errors are:
 - No load voltage
 - Fuse defective
 - Output overloaded
- 3) If an overload condition is detected, the output is inhibited for approximately 2.4 s.

3.25 Digital Output Module SM 322; DO 8 × 120/230 VAC/2 A; (6ES7 322-1FFx1-0AA0)

Order number: "Standard module"

6ES7 322-1FF01-0AA0

Order number: "SIMATIC Outdoor module"

6ES7 322-1FF81-0AA0

Characteristics

The SM 322; DO 8 × 120/230 VAC/2 A features the following characteristics:

- 8 outputs, fused and isolated in groups of 4
- 2 A output current
- 120/230 VAC rated load voltage
- Suitable for AC solenoid valves, contactors, motor starters, fractional h.p. motors and indicator lights.
- Group error display

Terminal assignment and block diagram of the SM 322; DO 8 × 120/230 VAC/2 A

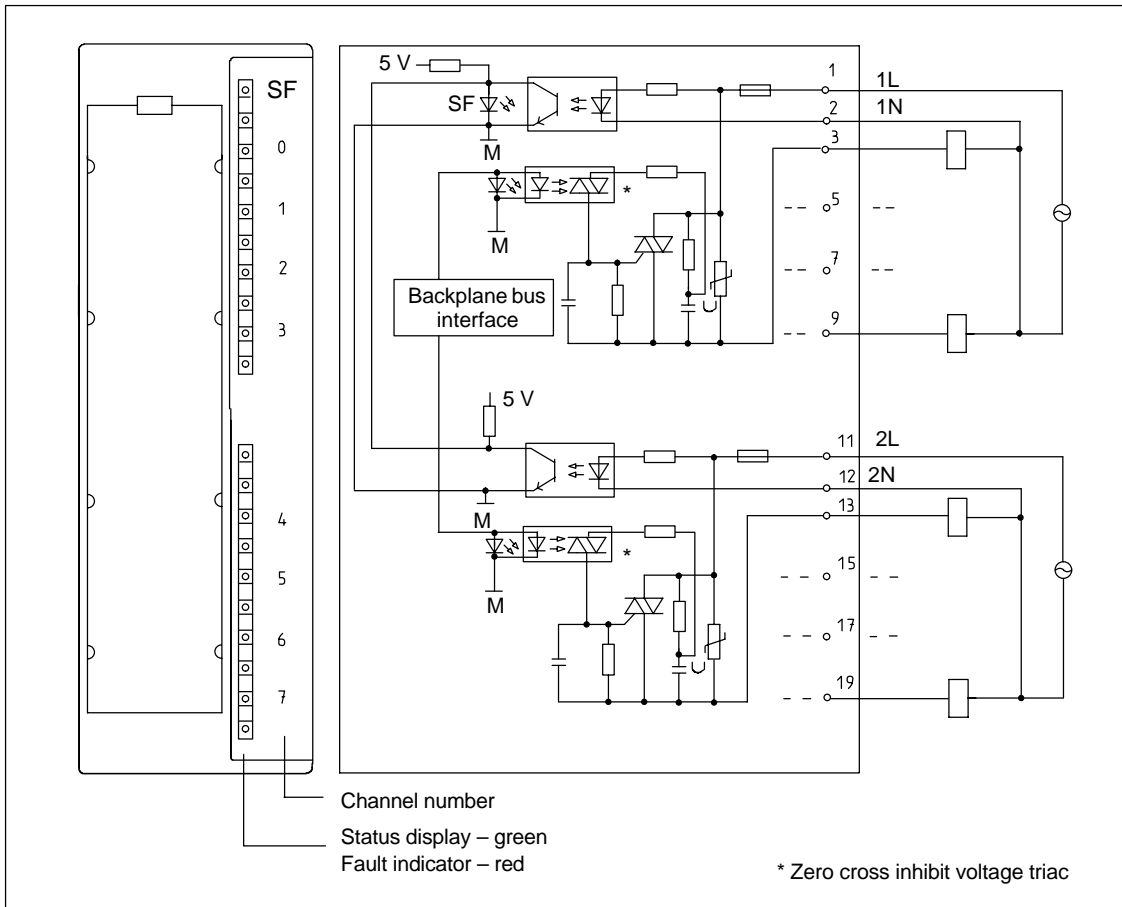

Figure 3-26 Module View and Block Diagram of the SM 322; DO 8 × 120/230 VAC/2 A

Technical specifications of the SM 322; DO 8 × 120/230 VAC/2 A

Dimensions and Weight		Data for Selecting an Actuator	
Dimensions W × H × D (in millimeters)	40 × 125 × 117	Output voltage	
Weight	Approx. 275 g	• At signal "1"	
Data for Specific Module		– At maximum current	min. L1 (–1.5 V)
Supports clocked operation	No	– At minimum current	min. L1 (–8.5 V)
Number of outputs	8	Output current	
Length of cable		• At signal "1"	
• Unshielded	max. 600 m	Rated value	AC 2 A ¹⁾
• Shielded	max. 1000 m	Permitted range for 0 °C to 40 °C	10 mA to 2 A
Voltages, Currents, Potentials		Permitted range for 40 °C to 60 °C	10 mA to 1 A
Rated load voltage L1	120/230 VAC	Permitted current surge (per group)	max. 20 A (not more than 1 AC scan cycle)
• Permitted frequency range	47 Hz to 63 Hz	• At signal "0" (leakage current)	max. 2 mA
Total current of the outputs (per group)		Output delay (for resistive load)	
• Horizontal configuration		• From "0" to "1"	Not more than 1 AC scan cycle
Up to 40 °C	max. 4 A	• From "1" to "0"	Not more than 1 AC scan cycle
Up to 60 °C	max. 2 A	Minimum load current	10 mA
• Vertical configuration		Zero cross inhibit voltage	max. 60 V
Up to 40 °C	max. 2 A	Size of the motor starter	max. size 5 to NEMA
Isolation		Lamp load	max. 50 W
• Between channels and backplane bus	Yes	Connecting two outputs in parallel	
• Between the channels	Yes	• For redundant triggering of a load	Possible (only outputs of the same group)
In groups of	4	• To increase performance	Not possible
Permitted potential difference		Triggering a digital input	Possible
• Between M _{internal} and the outputs	230 VAC	Switch rate	
• Between the outputs of the different groups	500 VAC	• For resistive load	max. 10 Hz
Insulation tested with	1500 VAC	• Inductive loads, according to IEC 947-5-1, AC 15	max. 0.5 Hz
Current consumption		• For lamp load	1 Hz
• From the backplane bus	max. 100 mA	Short-circuit protection of output	Fuse, 8 A/250 V; per group
• From load voltage L1 (without load)	max. 2 mA	• Min. current required for fuse to blow	min. 40 A
Power dissipation of the module	typ. 8.6 W	• Max. response time	max. 300 ms
Status, Interrupts, Diagnostics			
Status display	Green LED per channel		
Interrupts	None		
Diagnostic functions	Yes		
• Group error display	Red LED (SF) ²⁾		

Replacement fuses	8 A fuse/quick-acting
• Wickmann	194-1800-0
• Schurter	SP001.1013
• Littelfuse	217.008
Fuse carrier	
• Wickmann	653 07

1) The load current must not be half-wave

2) Potential errors are:

- No load voltage
- Fuse defective

3.26 Digital Output Module SM 322; DO 8 × 120/230 VAC/2 A ISOL (6ES7 322-5FF00-0AB0)

Order number

6ES7 322-5FF00-0AB0

Characteristics

Digital output module SM 322; DO 8 × 120/230 VAC/2 A ISOL has the following distinguishing characteristics:

- 8 outputs, isolated in one group
- Group error display
- Channel-specific status LEDs
- Programmable diagnostics
- Programmable diagnostic interrupt
- Programmable substitute value output
- 2 A output current
- 120/230 VAC rated load voltage
- Suitable for AC solenoid valves, contactors, motor starters, fractional h.p. motors and indicator lights.

Terminal assignment and block diagram of the SM 322; DO 8 × 120/230 VAC/2 A ISOL

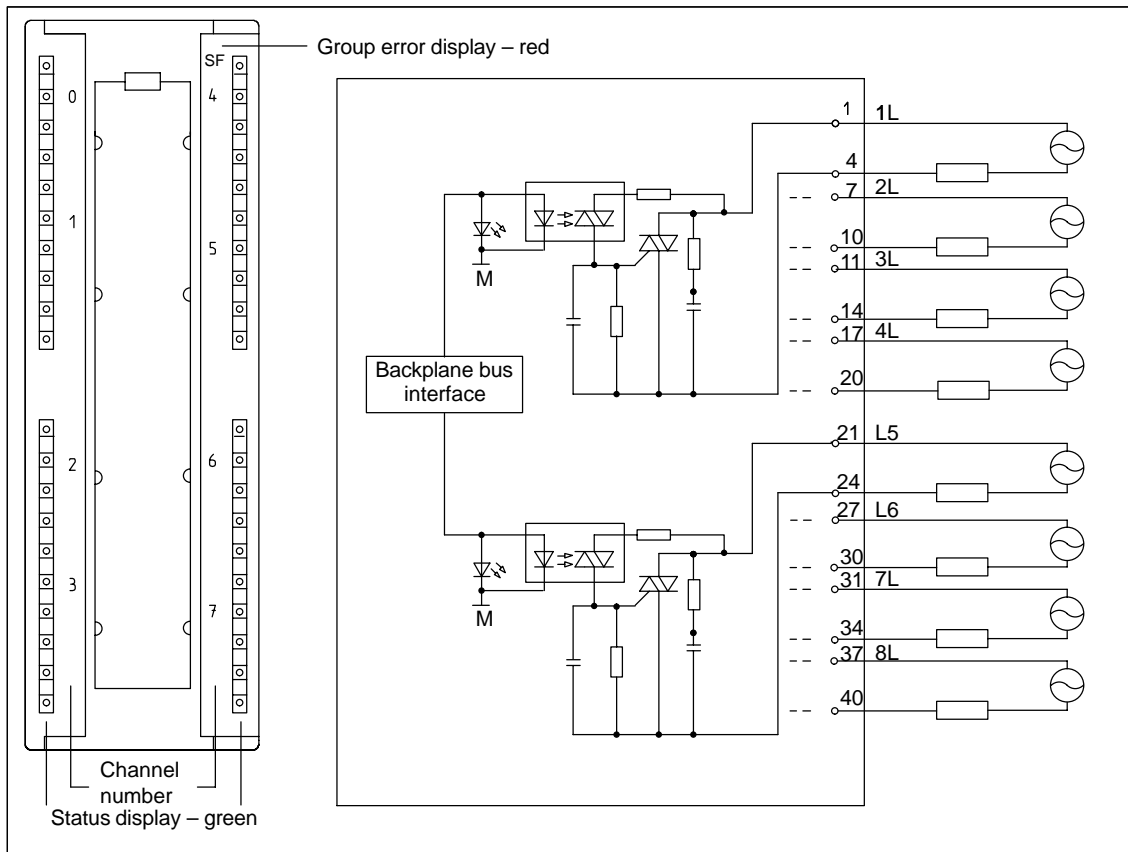

Figure 3-27 Module View and Block Diagram of the SM 322; DO 8 x 120/230 VAC/2 A ISOL

Technical specifications of the SM 322; DO 8 × 120/230 VAC/2 A ISOL

Dimensions and Weight		Status, Interrupts, Diagnostics	
Dimensions W × H × D (in millimeters)	40 × 125 × 117	Status display	Green LED per channel
Weight	Approx. 275 g	Interrupts	
Data for Specific Module		• Diagnostic Interrupt	Parameters can be assigned
Supports clocked operation	No	Diagnostics functions	
Number of outputs	8	• Group error display	Red LED (SF)
Length of cable		Data for Selecting an Actuator	
• Unshielded	max. 600 m	Output voltage	
• Shielded	max. 1000 m	• At signal "1"	min. L1 (-8.5 V)
Voltages, Currents, Potentials		Output current	
Rated load voltage L1	120/230 VAC	• At signal "1"	
Total current of the outputs (module)		Rated value	2 A
• Horizontal configuration		Permitted range for 0 °C to 40 °C	10 mA to 2 A
Up to 40 °C	max. 8 A	Permitted range for 40 °C to 60 °C	10 mA to 1 A
Up to 60 °C	max. 4 A	Permitted surge current (per group)	max. 20 A (with 2 half-waves)
• Vertical configuration	max. 4 A	• For "0" signal (leakage current)	max. 2 mA
Up to 40 °C		Zero cross inhibit voltage	max. 60 V
Isolation		Size of the motor starter	max. size 5 to NEMA
• Between channels and backplane bus	Yes	Lamp load	max. 50 W
• Between channels	Yes	Connecting two outputs in parallel	
In groups of	1	• For redundant triggering of a load	Possible
Permitted potential difference		• To increase performance	Not possible
• Between M _{internal} and the outputs	230 VAC	Triggering a digital input	Possible
• Between outputs	500 VAC	Switch rate	
Insulation tested with		• For resistive load	max. 10 Hz
• Between M _{internal} and the outputs	1500 VAC	• Inductive loads, according to IEC 947-5-1, AC 15	max. 0.5 Hz
• Between the outputs of the different groups	2000 VAC	• For lamp load	max. 1 Hz
Current consumption		Short-circuit protection of output	Yes, 3.15 A / 250 V fuse, fast-acting
• From the backplane bus	max. 100 mA		
• From load voltage L1 (without load)	max. 2 mA		
Power dissipation of the module	typ. 8.6 W		

Note

The outputs must be protected by a high-speed, fast-acting 3.15 A 250 VAC fuse. When mounted in a hazardous area in accordance with the National Electric Code, a tool must be used to remove the fuse and the area must be designated safe before the fuse is removed/replaced.

Parameterization of the SM 322; DO x 120/230 VAC/2 A ISOL

A description of the general procedure for parameterizing digital modules can be found in section 3.3.

Detailed information on the digital output module parameters can be found in Appendix A.3.

Parameters of the SM 322; DO 8 x 120/230 VAC/2 A ISOL

Table 3-22 shows the settable parameters with the default settings for the SM 322; DO 8 x 120/230 VAC/2 A ISOL.

The default settings apply if you have not performed parameter assignment in STEP 7.

Table 3-22 Parameters of the SM 322; DO 8 x 120/230 VAC/2 A ISOL

Parameter	Value Range	Default settings	Parameter type	Scope
Enable • Diagnostic interrupts	Yes/no	No	Dynamic	Module
Behavior on CPU STOP	Switch substitute value (EWS) Hold last value (LWH)	EWS	Dynamic	Channel
Switch substitute value "1"	Yes/no	No	Dynamic	Channel

Behavior and Diagnostics of the SM 322; DO 8 x 120/230 VAC/2 A ISOL

Table 3-23 gives an overview of the diagnostic messages of the SM 322; DO 8 x 120/230 VAC/2 A ISOL.

Table 3-23 Diagnostic Messages of the SM 322; DO 8 x 120/230 VAC/2 A ISOL

Diagnostics Message	LED	Scope of the Diagnostics	Parameters can be assigned
Time-out	SF	Module	No
EPROM error	SF	Module	No
RAM error	SF	Module	No

Error causes and remedies

Table 3-24 shows the diagnostic messages and error causes as well as the remedies of the SM 322; DO 8 x 120/230 VAC/2 A ISOL.

Table 3-24 Diagnostic Messages of the SM 322; DO 8 x 120/230 VAC/2 A ISOL, Error Causes and Remedies

Diagnostics Message	Error Detection	Possible Error Cause	Remedy
Time-out	Always	Transient high electromagnetic interference	Remove interference and turn the CPU power supply off and on
		Module defective	Replace module
EPROM error	Always	Transient high electromagnetic interference	Remove interference and turn the CPU power supply off and on
		Module defective	Replace module
RAM error	Always	Transient high electromagnetic interference	Remove interference and turn the CPU power supply off and on
		Module defective	Replace module

Interrupts of the SM 322; DO 8 x 120/230 VAC/2 A ISOL

The SM 322; DO 8 x 120/230 VAC/2 A ISOL can trigger diagnostic interrupts.

The OBs and SFCs mentioned below are described in detail in the online Help for STEP 7.

Enabling interrupts

The interrupts are not available – in other words, they are withheld without appropriate parameter assignment. Use STEP 7 to assign parameters for enabling interrupts.

Diagnostic interrupt

If you have enabled diagnostic interrupts, then active error events (initial occurrence of the error) and departing error events (message after troubleshooting) are reported by means of interrupts.

The CPU interrupts execution of the user program and processes the diagnostic interrupt block (OB 82).

In the user program, you can call SFC 51 or SFC 59 in OB 82 to obtain more detailed diagnostic information from the module.

The diagnostic information is consistent until such time as OB 82 is exited. When OB 82 is exited, the diagnostic interrupt is acknowledged at the module.

Load restrictions with a horizontal configuration

With a horizontal configuration, the module loads must be restricted so that two adjacent inputs or outputs do not exceed the maximum rating for an input or an output.

Load restrictions with a vertical configuration

With a vertical configuration, the module loads must be restricted so that four adjacent inputs or outputs do not exceed the maximum rating for an input or an output.

3.27 Relay Output Module SM 322; DO 16 × Rel. 120/230 VAC; (6ES7 322-1HH01-0AA0)

Order number

6ES7 322-1HH01-0AA0

Characteristics

The SM 322; DO 16 × Rel. 120/230 VAC features the following characteristics:

- 16 outputs, isolated in groups of 8
- Rated load voltage 24 VDC to 120 VDC, 48 VAC to 230 VAC
- Suitable for AC/DC solenoid valves, contactors, motor starters, fractional h.p. motors and indicator lights.

Behavior upon power down of the supply voltage

Note

When the power supply is switched off, the capacitor still stores energy for about 200 ms. The relay can therefore still be driven briefly within this time by the user program.

**Terminal assignment and block diagram of the SM 322;
DO 16 × Rel. 120/230 VAC**

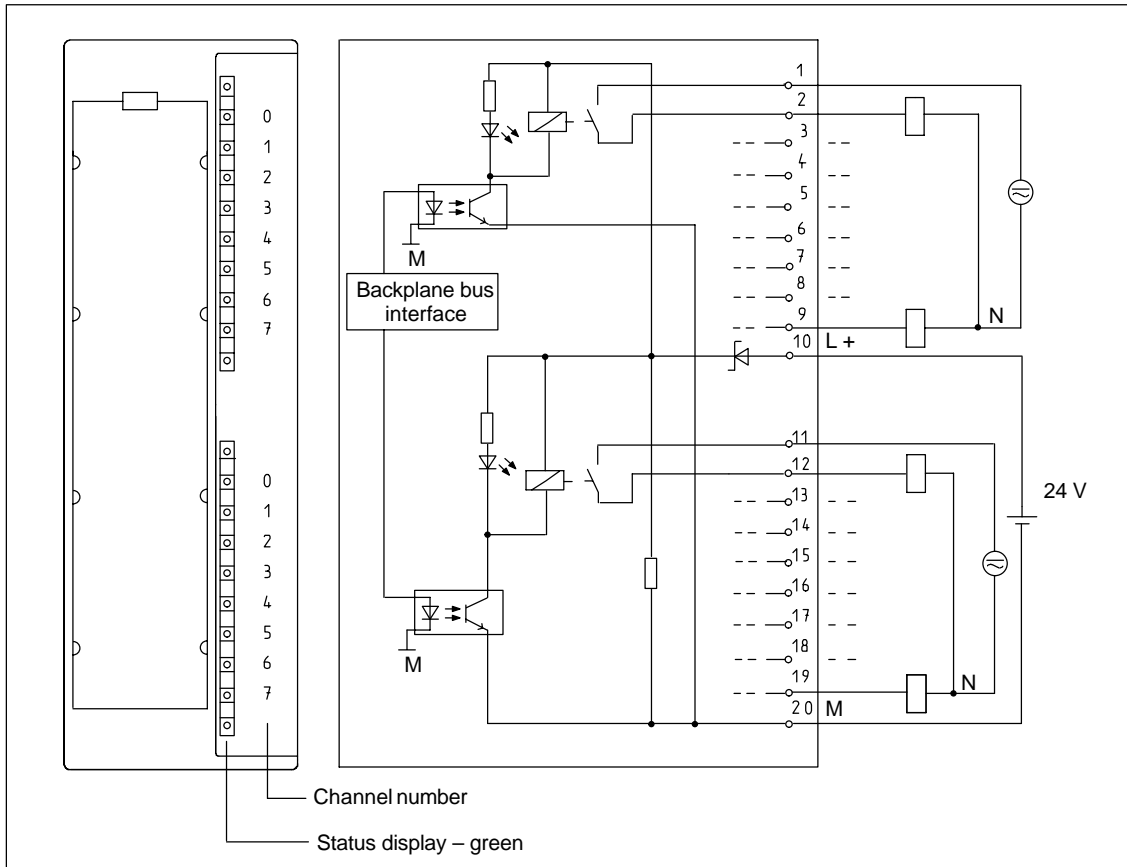

Figure 3-28 Module View and Block Diagram of SM 322; DO 16 × Rel. 120/230 VAC

Technical specifications of the SM 322; DO 16 × Rel. 120/230 VAC

Dimensions and Weight		Status, Interrupts, Diagnostics			
Dimensions W × H × D (in millimeters)	40 × 125 × 117	Status display	Green LED per channel		
Weight	Approx. 250 g	Interrupts	None		
Data for Specific Module		Diagnostic functions	None		
Supports clocked operation	No	Data for Selecting an Actuator			
Number of outputs	16	Continuous thermal current	max. 2 A		
Length of cable		Minimum load voltage / current	10 V / 10 mA		
• Unshielded	max. 600 m	Short-circuit proof to IEC 947-5-1	200 A, with B10/B16 circuit breaker		
• Shielded	max. 1000 m	Switching capacity and lifetime of the contacts			
Voltag es, Currents, Potentials		• For resistive load			
Rated supply voltage of the relay L +	24 VDC		Voltage	Current	No. of switching cyc. (typ.)
Total current of the outputs (per group)	max. 8 A		24 VDC	2.0 A	0.1 million
Isolation				1.0 A	0.2 million
• Between channels and backplane bus	Yes			0.5 A	1.0 million
• Between the channels	Yes		60 VDC	0.5 A	0.2 million
In groups of	8		120 VDC	0.2 A	0.6 million
Permitted potential difference			24 VAC	1.5 A	1.5 million
• Between M _{internal} and supply voltage of the relays	75 VDC / 60 VAC		48 VAC	1.5 A	1.5 million
• Between M _{internal} and supply voltage of the relays and the outputs	230 VAC		60 VAC	1.5 A	1.5 million
• Between the outputs of the different groups	500 VAC		120 VAC	2.0 A	1.0 million
Insulation tested with				1.0 A	1.5 million
• Between M _{internal} and supply voltage of the relays	500 VDC			0.5 A	2.0 million
• Between M _{internal} and supply voltage of the relays and the outputs	1500 VAC		230 VAC	2.0 A	1.0 million
• Between the outputs of the different groups	2000 VAC			1.0 A	1.5 million
Current consumption				0.5 A	2.0 million
• From the backplane bus	max. 100 mA			2.0 A	0.7 million
• From supply voltage L+	max. 250 mA			1.0 A	1.0 million
Power dissipation of the module	typ. 4.5 W			0.5 A	1.5 million
		• Inductive load according to IEC 947-5-1 DC13/AC15			
			Voltage	Current	No. of switching cyc. (typ.)
			24 VDC	2.0 A	0.05 million
				1.0 A	0.1 million
				0.5 A	0.5 million
			60 VDC	0.5 A	0.1 million
			120 VDC	0.2 A	0.3 million
			24 VAC	1.5 A	1 million
			48 VAC	1.5 A	1 million
			60 VAC	1.5 A	1 million
			120 VAC	2.0 A	0.7 million
				1.0 A	1.0 million
				0.5 A	1.5 million
			230 VAC	2.0 A	0.7 million
				1.0 A	1.0 million
				0.5 A	1.5 million
		An external protection circuit will enhance the service life of the contacts.			

Size of the motor starter	max. size 5 to NEMA	Triggering a digital input	Possible
Lamp load	50 W / 230 VAC 5 W / 24 VDC	Switch rate	
Contact protection (internal)	None	• Mechanical	max. 10 Hz
Parallel connection of 2 outputs		• For resistive load	1 Hz
• For redundant triggering of a load	Possible (only outputs of the same group)	• Inductive loads according to IEC 947-5-1, DC 13/AC 15	max. 0.5 Hz
• To increase performance	Not possible	• For lamp load	1 Hz

3.28 Relay Output Module SM 322; DO 8 × Rel. 230 VAC; (6ES7 322-1HF01-0AA0)

Order number

6ES7 322-1HF01-0AA0

Characteristics

The SM 322; DO 8 × REL. 230 VAC features the following characteristics:

- 8 outputs, isolated in groups of 2
- Rated load voltage 24 VDC to 120 VDC, 48 VAC to 230 VAC
- Suitable for AC/DC solenoid valves, contactors, motor starters, fractional h.p. motors and indicator lights.

Behavior upon power down of the supply voltage

Note

Applicable only for the SM 322; DO 8 × Rel. 230 VAC with product status 1 is:

When the power supply is switched off, the capacitor still stores energy for about 200 ms. The relay can therefore still be driven briefly within this time by the user program.

Terminal assignment and block diagram of the SM 322; DO 8 × Rel. 230 VAC

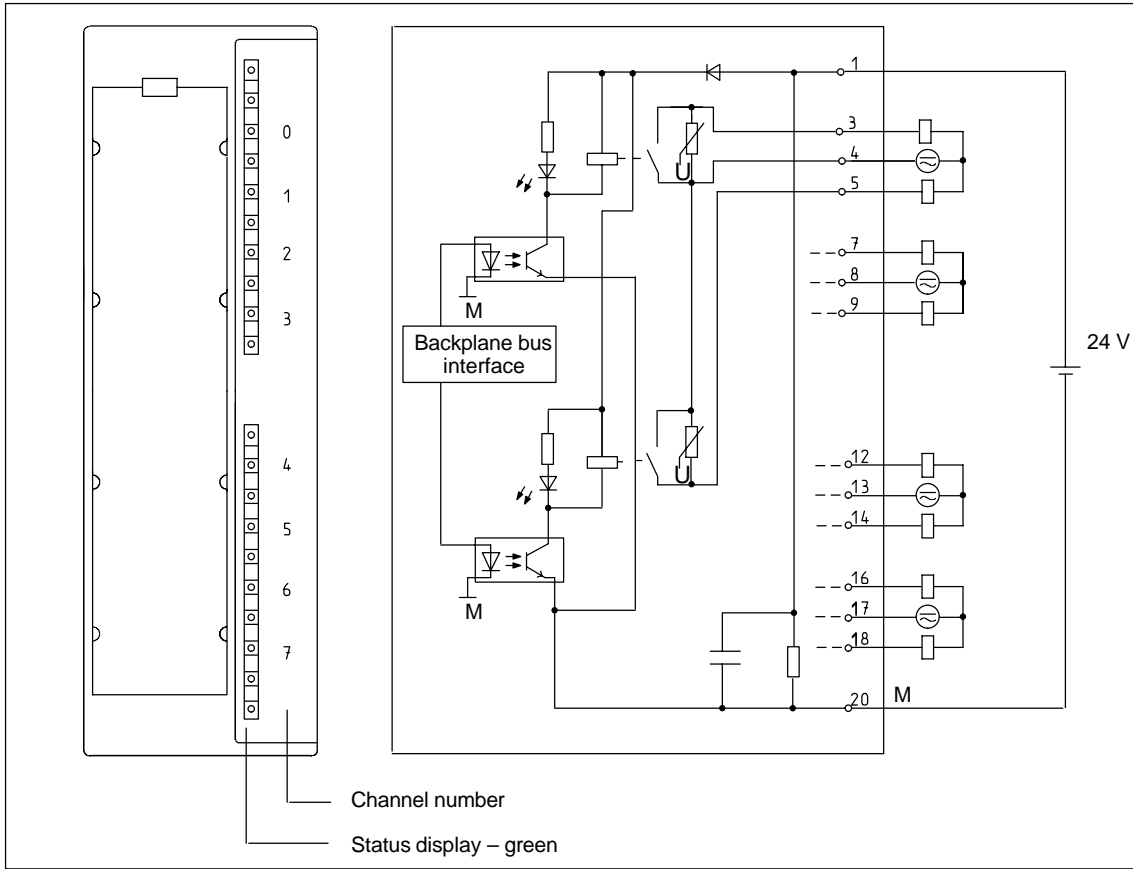

Figure 3-29 Module View and Block Diagram of the SM 322; DO 8 × REL. 230 VAC

Data for Selecting an Actuator, continued			Connecting two outputs in parallel	
Lamp load ¹⁾	max. 50 W		• For redundant triggering of a load	Possible (only outputs of the same group)
	Power	No. of switching cyc. (typ.)	• To increase performance	Not possible
Lamp load (230 VAC) ²⁾	1000 W	25000	Triggering a digital input	Possible
	1500 W	10000	Switch rate	
Energy-saving lamps/fluorescent lamps with electronic ballast ²⁾	10×58W	25000	• Mechanical	max. 10 Hz
Fluorescent lamps, conventionally compensated ²⁾	1 × 58W	25000	• For resistive load	max. 2 Hz
Fluorescent lamps, non-compensated ²⁾	10×58W	25000	• Inductive loads according to IEC 947-5-1, DC 13/15 AC	max. 0.5 Hz
			• For lamp load	max. 2 Hz

1) Product status 1

2) Product status 2 or later

3.29 Relay Output Module SM 322; DO 8 × Rel. 230 VAC/5A; (6ES7 322-5HF00-0AB0)

Order number

6ES7 322-5HF00-0AB0

Characteristics

Relay output module SM 322; DO 8 × Rel. 230 VAC/5A has the following distinguishing characteristics:

- 8 outputs, isolated in groups of 1
- Load voltage 24 VDC to 120 VDC, 24 VAC to 230 VAC
- Suitable for AC solenoid valves, contactors, motor starters, fractional h.p. motors and indicator lights.
- An RC quenching element can be connected via a jumper (SJ) to protect the contacts.
- Group error display
- Channel-specific status LEDs
- Programmable diagnostic interrupt
- Programmable substitute value output

Protection of contacts against overvoltages

You protect the contacts against overvoltages by inserting jumpers (SJ) on the module between terminals 3 and 4, 7 and 8, 12 and 13 etc. (refer to Figure 3-30).

Terminal assignment and block diagram of the SM 322; DO 8 x Rel. 230 VAC/5A

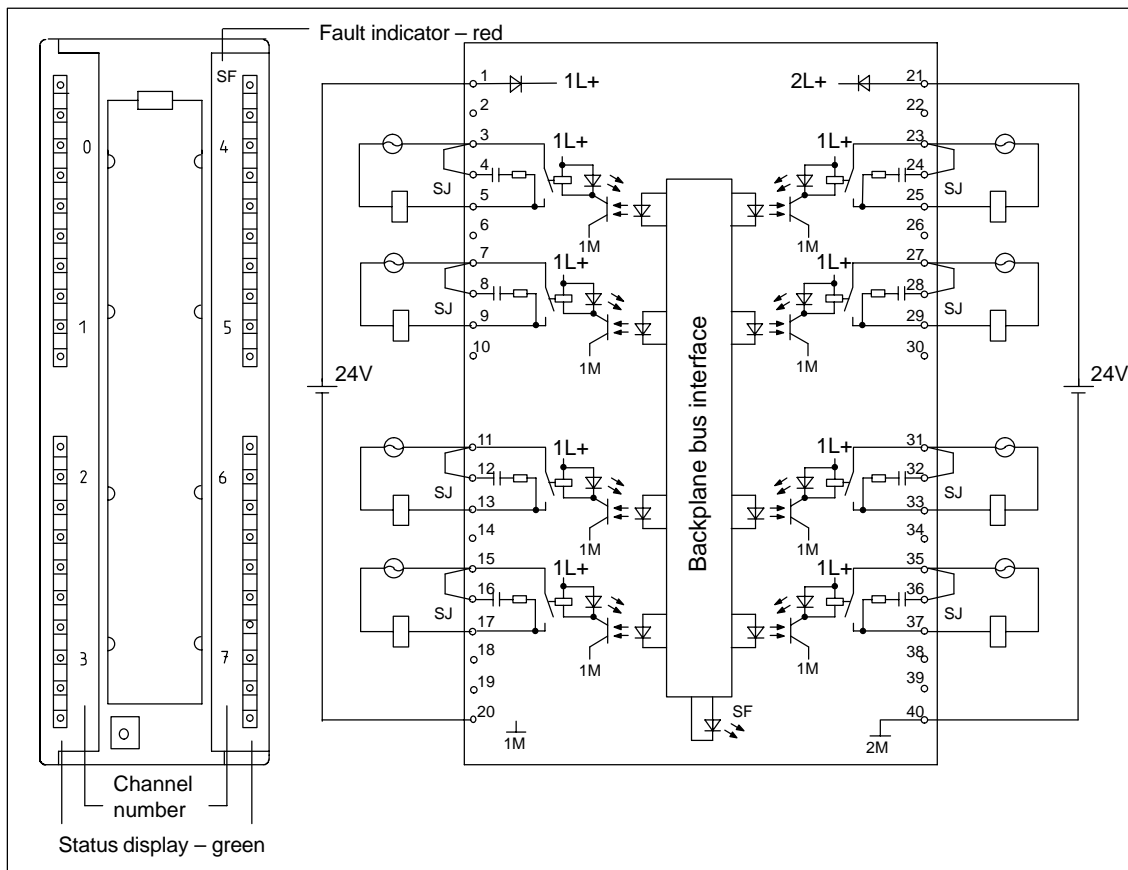

Figure 3-30 Module View and Block Diagram of the SM 322; DO 8 x Rel. 230 VAC/5A

Operation with safe electrical extra-low voltage

When using relay output module 6ES7 322-5HF00-0AB0 with safe and electrically isolated extra-low voltage, take the following special characteristic into account:

If a terminal is operated with a safe and electrically isolated extra-low voltage, the horizontally adjacent terminal must be operated at a rated voltage of not more than 120 VUC. With operation at voltages greater than 120 VUC, the creepages and clearances of the 40-pin front connector do not meet the SIMATIC requirements for safe electrical isolation.

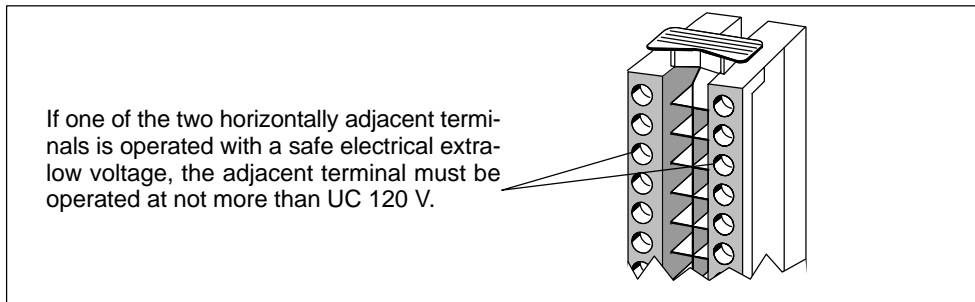

Figure 3-31 Special Characteristic for Operation with a Safe Electrical Extra-Low Voltage

Technical specifications of the SM 322; DO 8 × Rel. 230 VAC/5 A

Dimensions and Weight			
Dimensions W × H × D (in millimeters)	40 × 125 × 117		
Weight	Approx. 320 g		
Data for Specific Module			
Supports clocked operation	No		
Number of outputs	8		
Length of cable			
• Unshielded	max. 600 m		
• Shielded	max. 1000 m		
Voltages, Currents, Potentials			
Rated supply voltage of the electronics L +	24 VDC		
• Reverse polarity protection	Yes		
Total current of the outputs (per group)			
• Horizontal configuration Up to 60° C	max. 5 A		
• Vertical configuration Up to 40° C	max. 5 A		
Isolation			
		• Between channels and backplane bus	Yes
		• Between the channels and the relay supply voltage	Yes
		• Between the channels In groups of	Yes 1
		Permitted potential difference	
		• Between M _{internal} and supply voltage of the relays	75 VDC / 60 VAC
		• Between M _{internal} and supply voltage of the relays and the outputs	250 VAC
		• Between the outputs of the different groups	500 VAC

Insulation tested with <ul style="list-style-type: none"> Between $M_{Internal}$ and supply voltage of the relays 500 VDC Between $M_{Internal}$ and supply voltage of the relays and the outputs 1500 VAC Between the outputs of the different groups 2000 VAC 																						
Current consumption <ul style="list-style-type: none"> From the backplane bus max. 100 mA From supply voltage L+ max. 160 mA 																						
Power dissipation of the module typ. 3.5 W																						
Status, Interrupts, Diagnostics																						
Status display	Green LED per channel																					
Interrupts <ul style="list-style-type: none"> Diagnostic Interrupt Parameters can be assigned 																						
Diagnostic functions Parameters can be assigned <ul style="list-style-type: none"> Group error display Red LED (SF) Diagnostics information read-out Possible 																						
Data for Selecting an Actuator																						
Continuous thermal current	max. 5 A																					
Minimum load voltage / current	10 V /10 mA ¹⁾																					
Leakage current	11.5 mA ²⁾																					
Short-circuit proof according to IEC 947-5-1	With circuit-breaker of characteristic B for: cos ϕ 1.0: 600 A cos ϕ 0.5 to 0.7: 900 A With Diazed 8 A fuse: 1000 A																					
Switching capacity and lifetime of the contacts <ul style="list-style-type: none"> For resistive load <table border="1" style="margin-left: 20px;"> <thead> <tr> <th>Voltage</th> <th>Current</th> <th>No. of switching cyc. (typ.)</th> </tr> </thead> <tbody> <tr><td>24 VDC</td><td>5.0 A</td><td>0.2 million</td></tr> <tr><td>24 VDC</td><td>2.5 A</td><td>0.4 million</td></tr> <tr><td>24 VDC</td><td>1.0 A</td><td>0.9 million</td></tr> <tr><td>230 VAC</td><td>5.0 A</td><td>0.2 million</td></tr> <tr><td>230 VAC</td><td>2.5 A</td><td>0.4 million</td></tr> <tr><td>230 VAC</td><td>1.0 A</td><td>0.9 million</td></tr> </tbody> </table> 		Voltage	Current	No. of switching cyc. (typ.)	24 VDC	5.0 A	0.2 million	24 VDC	2.5 A	0.4 million	24 VDC	1.0 A	0.9 million	230 VAC	5.0 A	0.2 million	230 VAC	2.5 A	0.4 million	230 VAC	1.0 A	0.9 million
Voltage	Current	No. of switching cyc. (typ.)																				
24 VDC	5.0 A	0.2 million																				
24 VDC	2.5 A	0.4 million																				
24 VDC	1.0 A	0.9 million																				
230 VAC	5.0 A	0.2 million																				
230 VAC	2.5 A	0.4 million																				
230 VAC	1.0 A	0.9 million																				
<ul style="list-style-type: none"> Inductive load according to IEC 947-5-1 13 DC/15 AC <table border="1" style="margin-left: 20px;"> <thead> <tr> <th>Voltage</th> <th>Current</th> <th>No. of switching cyc. (typ.)</th> </tr> </thead> <tbody> <tr><td>24 VDC</td><td>5.0 A</td><td>0.1 million</td></tr> <tr><td>24 VDC</td><td>2.5 A</td><td>0.25 million</td></tr> <tr><td>24 VDC</td><td>1.0 A</td><td>0.5 million</td></tr> <tr><td>230 VAC</td><td>5.0 A</td><td>0.1 million</td></tr> <tr><td>230 VAC</td><td>2.5 A</td><td>0.25 million</td></tr> <tr><td>230 VAC</td><td>1.0 A</td><td>0.5 million</td></tr> </tbody> </table> 		Voltage	Current	No. of switching cyc. (typ.)	24 VDC	5.0 A	0.1 million	24 VDC	2.5 A	0.25 million	24 VDC	1.0 A	0.5 million	230 VAC	5.0 A	0.1 million	230 VAC	2.5 A	0.25 million	230 VAC	1.0 A	0.5 million
Voltage	Current	No. of switching cyc. (typ.)																				
24 VDC	5.0 A	0.1 million																				
24 VDC	2.5 A	0.25 million																				
24 VDC	1.0 A	0.5 million																				
230 VAC	5.0 A	0.1 million																				
230 VAC	2.5 A	0.25 million																				
230 VAC	1.0 A	0.5 million																				
With a connected RC quenching element (jumper "SJ" inserted) or with an external protection circuit, you lengthen the service life of the contacts.																						
Size of the motor starter	max. size 5 to NEMA																					
	Power No. of switching cyc. (typ.)																					
Lamp load (230 VAC)	1000 W 25000 1500 W 10000																					
Energy-saving lamps/fluorescent lamps with electronic ballast	10 × 58W 25000																					
Fluorescent lamps, conventionally compensated	1 × 58W 25000																					
Fluorescent lamps, non-compensated	10 × 58W 25000																					
Contact protection	RC quenching element 330 Ω , 0.1 μ F																					
Connecting two outputs in parallel <ul style="list-style-type: none"> For redundant triggering of a load Possible (only outputs with identical load voltage) To increase performance Not possible 																						
Triggering a digital input	Possible																					
Switch rate <ul style="list-style-type: none"> Mechanical max. 10 Hz For resistive load max. 2 Hz Inductive loads according to IEC 947-5-1, DC 13/15 AC max. 0.5 Hz For lamp load max. 2 Hz 																						

1) Without inserted jumper (SJ).
 2) For AC load voltage and inserted jumper (SJ). Without jumper (SJ) inserted there is a leakage current

Note

Due to the leakage current of the RC quenching element, wrong signal states might occur when an IEC Type 1 input is connected (remove SJ jumper)

3.29.1 SM 322; DO 8 × Rel. 230 VAC/5A parameterization

Parameterization

You will find the general procedure for assigning parameters to digital modules in Section 3.3.

Parameters of the SM 322; DO 8 × Rel. 230 VAC/5A

You will find an overview of the parameters that you can set and their default settings for the SM 322; DO 8 × 230 VDC/0.5 A in the table below.

Table 3-25 Parameters of the SM 322; DO 8 × Rel. 230 VAC/5A

Parameter	Value Range	Default settings	Parameter type	Scope
Enable				
• Diagnostic Interrupts	Yes/no	No	Dynamic	Module
Behavior on CPU STOP	Switch substitute value (EWS) Hold last value (LWH)	EWS	Dynamic	Channel
Switch substitute value "1"	Yes/no	No	Dynamic	Channel

3.29.2 Behavior and Diagnostics of the SM 322; DO 8 × 230 VDC/0.5 A

Diagnostic messages of the SM 322; DO 8 × Rel. 230 VAC/5A

The table below presents an overview of the diagnostic messages for the SM 322; DO 8 × Rel. 230 VAC/5 A.

Table 3-26 Diagnostic Messages of the SM 322; DO 8 × Rel. AC 230 VDC/0.5 A

Diagnosics Message	LED	Scope of the Diagnostics	Parameters can be Assigned
Time-out	SF	Module	No
EPROM error	SF	Module	No
RAM error	SF	Module	No

Error causes and remedies

Table 3-27 Diagnostic Messages of the SM 322; DO 8 × Rel. 230 VAC/5A, Error Causes and Remedies

Diagnosics Message	Error Detection	Possible Error Cause	Remedy
Time-out	Always	Temporary high electromagnetic interference	Remove interference and turn the CPU power supply off and on
		Module defective	Replace module
EPROM error	Always	Temporary high electromagnetic interference	Remove interference and turn the CPU power supply off and on
		Module defective	Replace module
RAM error	Always	Temporary high electromagnetic interference	Remove interference and turn the CPU power supply off and on
		Module defective	Replace module

Interrupts of the SM 322; DO 8 × Rel. 230 VAC/5A

Introduction

The SM 322; DO8 × Rel. 230 VAC/0.5 A can trigger diagnostic interrupts.

The OBs and SFCs mentioned below can be found in the online Help for STEP 7, where they are described in greater detail.

Enabling interrupts

The interrupts are not available – in other words, they are inhibited without appropriate parameter assignment. Use STEP 7 to assign parameters for enabling interrupts.

Diagnostic Interrupt

If you have enabled diagnostic interrupts, then incoming active error events (initial occurrence of the error) and departing error events (message after troubleshooting) are reported by means of interrupts.

The CPU interrupts execution of the user program and processes the diagnostic interrupt block (OB 82).

In the user program, you can call SFC 51 or SFC 59 in OB 82 to obtain more detailed diagnostic information from the module.

The diagnostic information is consistent until such time as OB 82 is exited. When OB 82 is exited, the diagnostic interrupt is acknowledged on the module.

3.30 Relay Output Module SM 322; DO 8 × Rel. 230 VAC/5 A; (6ES7 322-1HFx0-0AA0)

Order number: "Standard module"

6ES7 322-1HF10-0AA0

Order number: "SIMATIC Outdoor module"

6ES7 322-1HF80-0AA0

Characteristics

The SM 322; DO 8 × Rel. 230 VAC/5 A features the following characteristics:

- 8 outputs, isolated in groups of 1
- Rated load voltage 24 VDC to 120 VDC, 48 VAC to 230 VAC
- Suitable for AC/DC solenoid valves, contactors, motor starters, fractional h.p. motors and indicator lights.

Measures with switching currents > 3 A

Note

To keep the additional temperature rise of the module near the connectors as low as possible, you must select a cable cross-section of 1.5 mm² for connecting cables with switching currents > 3 A.

Terminal assignment and block diagram of the SM 322; DO 8 × Rel. 230 VAC/5 A

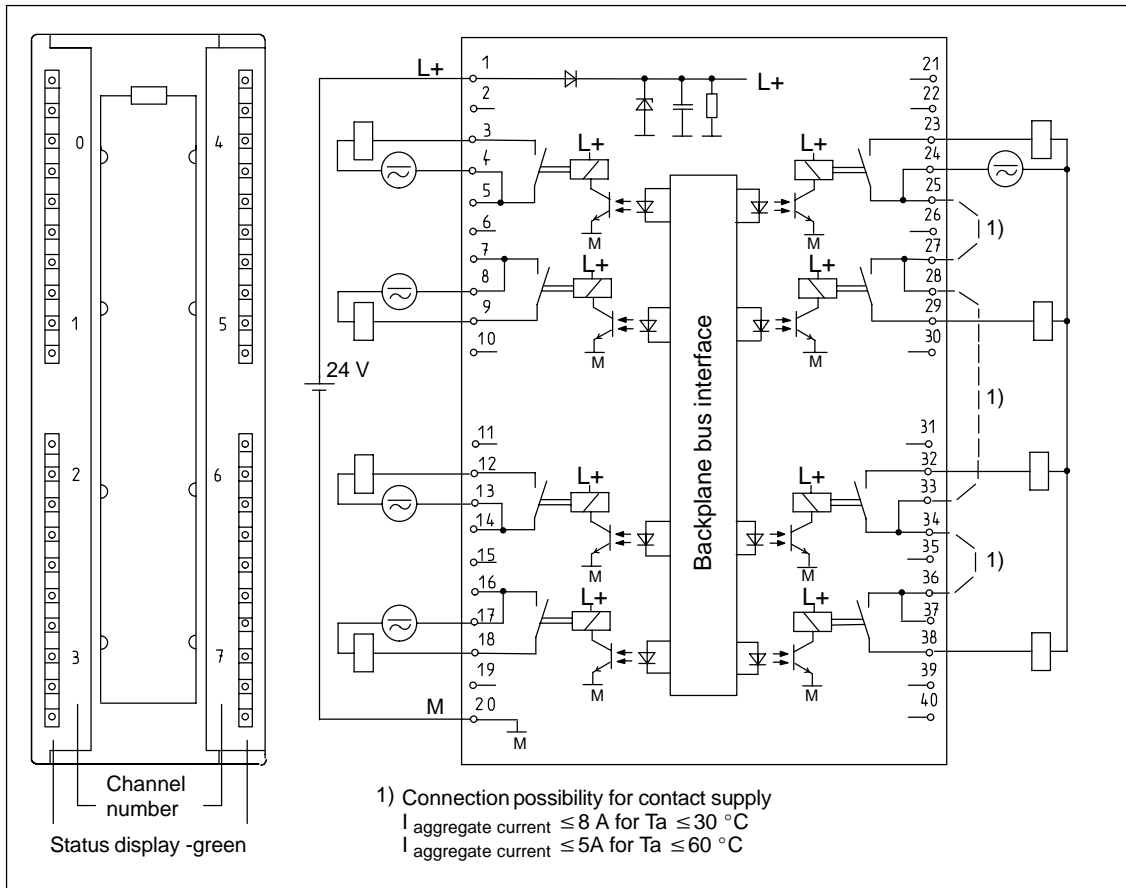

Figure 3-32 Module View and Block Diagram of the SM 322; DO 8 × Rel. 230 VAC/5 A

Operation with safe electrical extra-low voltage

When using relay output module 322-1HF10 with safe and electrically isolated extra-low voltage, take the following special characteristic into account:

If a terminal is operated with a safe and electrically isolated extra-low voltage, the horizontally adjacent terminal must be operated at a rated voltage of not more than 120 VUC. With operation at voltages greater than 120 VUC, the creepages and clearances of the 40-pin front connector do not meet the SIMATIC requirements for safe electrical isolation.

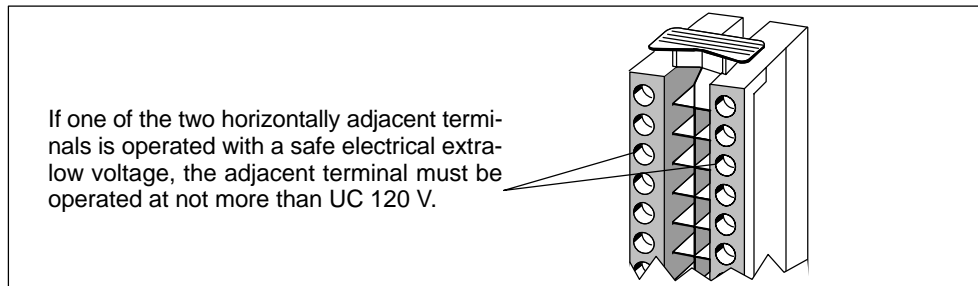

Figure 3-33 Special Characteristic for Operation with a Safe Electrical Extra-Low Voltage

Technical specifications of the SM 322; DO 8 × Rel. 230 VAC/5 A

Dimensions and Weight	
Dimensions W × H × D (in millimeters)	40 × 125 × 120
Weight	Approx. 320 g
Data for Specific Module	
Supports clocked operation	No
Number of outputs	8
Length of cable	
• Unshielded	max. 600 m
• Shielded	max. 1000 m
Voltages, Currents, Potentials	
Rated supply voltage of the relay L +	24 VDC
Total current of the outputs (per group)	
• Horizontal configuration	
Up to 30 °C	max. 8 A
Up to 60 °C	max. 5 A
• Vertical configuration	max. 5 A
Up to 40 °C	
Isolation	
• Between channels and backplane bus	Yes
• Between the channels	Yes
In groups of	1

Permitted potential difference	
• Between M _{internal} and supply voltage of the relays	75 VDC / 60 VAC
• Between M _{internal} and supply voltage of the relays and the outputs	250 VAC
• Between the outputs of the different groups	500 VAC
Insulation tested with	
• Between M _{internal} and supply voltage of the relays	500 VDC
• Between M _{internal} and supply voltage of the relays and the outputs	1500 VAC
• Between the outputs of the different groups	2000 VAC
Current consumption	
• From the backplane bus	max. 40 mA
• From supply voltage L+	max. 125 mA
Power dissipation of the module	typ. 4.2 W

Status, Interrupts, Diagnostics			
Status display	Green LED per channel		
Interrupt	None		
Diagnostic functions	None		
Data for Selecting an Actuator			
Continuous thermal current	max. 8 A		
Minimum load voltage / current	10 V / 5 mA		
Short-circuit proof to IEC 947-5-1	With circuit-breaker of characteristic B for: cos ϕ 1.0: 600 A cos ϕ 0.5 to 0.7: 900 A With Diazed 8 A fuse: 1000 A		
Switching capacity and lifetime of the contacts			
<ul style="list-style-type: none"> For resistive load 			
	Voltage	Current	No. of switching cyc. (typ.)
	24 VDC	8.0 A	0.1 million
		4.0 A	0.3 million
		2.0 A	0.7
		0.5 A	4.0 million
	60 VDC	0.5 A	4 million
	120 VDC	0.2 A	1.6 mill.
	48 VAC	8.0 A	0.1 million
		2.0 A	1.6 million
	60 VAC	8.0 A	0.1 million
		2.0 A	1.2 million
	120 VAC	8.0 A	0.1 million
		4.0 A	0.3 million
		2.0 A	0.5 million
		1.0 A	0.7 million
		0.5 A	1.5 million
	230 VAC	8.0 A	0.1 million
		4.0 A	0.3 million
		2.0 A	0.5 million
		1.0 A	0.7 million
		0.5 A	1.5 million
Switching capacity and lifetime of the contacts			
<ul style="list-style-type: none"> Inductive load according to IEC 947-5-1 13 DC/15 AC 			
	Voltage	Current	No. of switching cyc. (typ.)
	24 VDC	2.0 A	0.3 million
		1.0 A	0.5 million
		0.5 A	1 million
	60 VDC	0.5 A	0.5 million
		0.3 A	1 million
	120 VDC	0.2 A	0.5 mill.

48 VAC	3.0 A	0.5 million
	1.5 A	1 million
60 VAC	3.0 A	0.3 million
	1.5 A	1 million
120 VAC	3.0 A	0.2 million
	2.0 A	0.3 million
	1.0 A	0.7 million
	0.5 A	2.0 million
230 VAC	3.0 A	0.1 million
	2.0 A	0.3 million
	1.0 A	0.7 million
	0.5 A	2.0 million
<ul style="list-style-type: none"> Aux. contactors Size 0 (3TH28) 		30 mill.
An external protection circuit will enhance the service life of the contacts.		
	Power	No. of switching cyc. (typ.)
Lamp load (230 VAC)	1000W	25000
	1500W	10000
Energy-saving lamps/fluorescent lamps with electronic ballast	10 \times 58W	25000
Fluorescent lamps, conventionally compensated	1 \times 58W	25000
Fluorescent lamps, non-compensated	10 \times 58W	25000
Contact protection (internal)	None	
Connecting two outputs in parallel		
<ul style="list-style-type: none"> For redundant actuation of a load 	Possible	
<ul style="list-style-type: none"> To increase performance 	Not possible	
Triggering a digital input	Possible	
Switch rate		
<ul style="list-style-type: none"> Mechanical 	max. 10 Hz	
<ul style="list-style-type: none"> For resistive load 	max. 2 Hz	
<ul style="list-style-type: none"> Inductive loads according to IEC 947-5-1, DC 13/15 AC 	max. 0.5 Hz	
<ul style="list-style-type: none"> For lamp load 	max. 2 Hz	

3.31 Digital Input/Output Module SM 323; DI 16/DO 16 × 24 VDC/0.5 A; (6ES7 323-1BL00-0AA0)

Order number

6ES7 323-1BL00-0AA0

Characteristics

The SM 323; DI 16/DO 16 × 24 VDC/0.5 A features the following characteristics:

- 16 inputs, isolated in groups of 16
- 16 outputs, isolated in groups of 8
- 24 VDC rated input voltage
- 24 VDC rated load voltage
- Inputs suitable for switches and two / three / four-wire BEROs (proximity switches)
- Outputs suitable for solenoid valves, DC contactors and indicator lights

Using the module with high-speed counters

Please take note of the following information on the use of the module in connection with high-speed counters:

Note

When connecting the 24 V power supply via a mechanical contact, the outputs of the SM 323; DI 16/DO 16 × 24 VDC/0.5 A carry a "1" signal for approximately 50 µs for reasons associated with the circuitry.

**Terminal assignment and block diagram of the SM 323;
DI 16/DO 16 × 24 VDC/0.5 A**

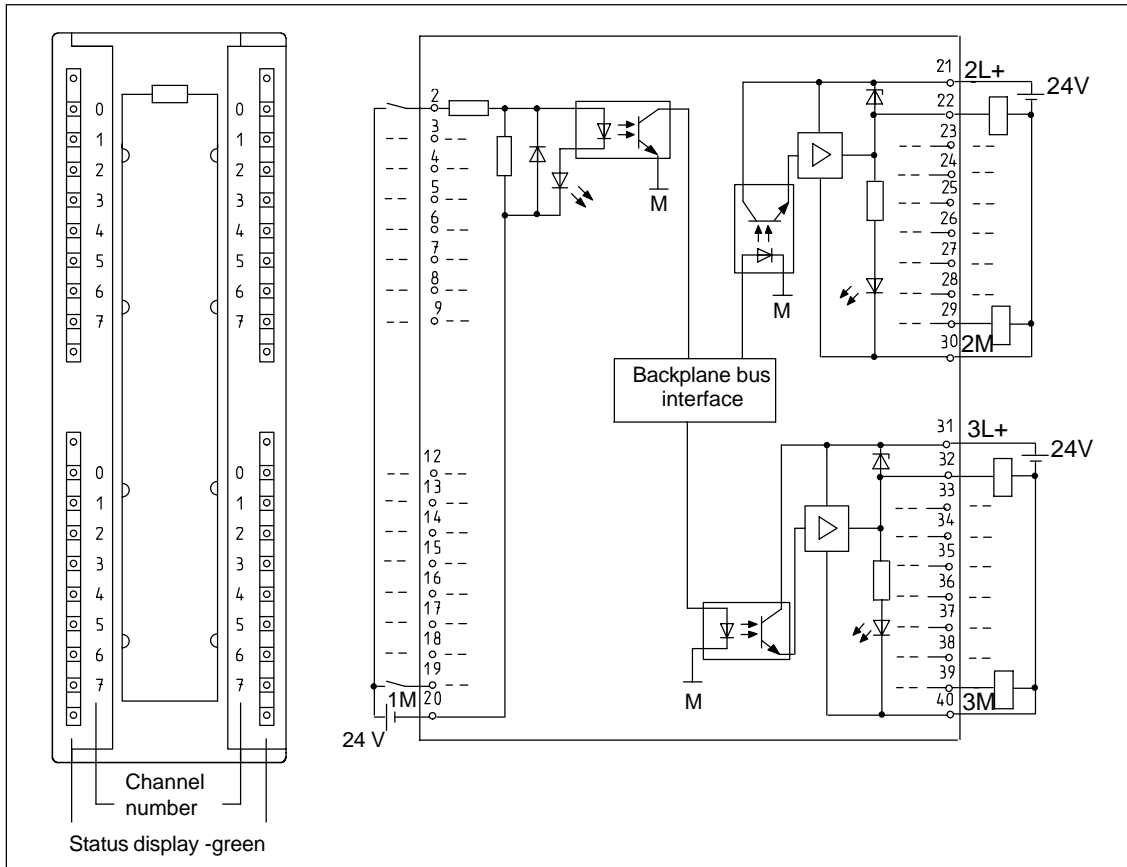

Figure 3-34 Module View and Block Diagram of the SM 323; DI 16/DO 16 × 24 VDC/0.5 A

Terminal assignment

The figure below shows the assignment of the channels to the input and output addresses.

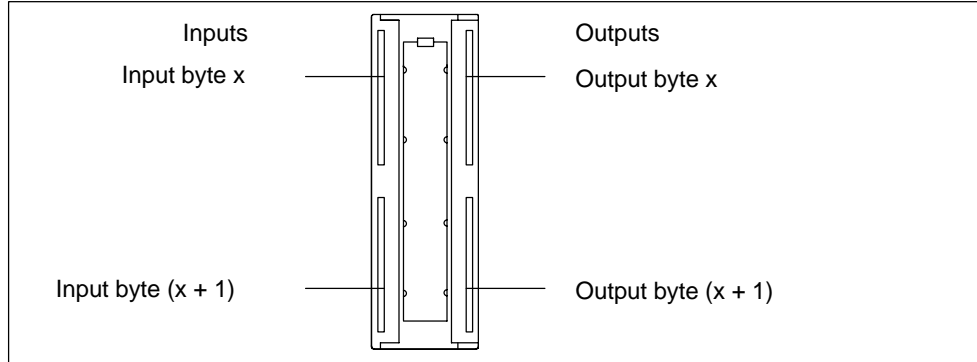

Figure 3-35 Terminal Assignment of the SM 323; DI 16/DO 16 × 24 VDC/0.5 A

Technical specifications of the SM 323; DI 16/DO 16 × 24 VDC/0.5 A

Dimensions and Weight	
Dimensions W × H × D (in millimeters)	40 × 125 × 117
Weight	Approx. 260 g
Data for Specific Module	
Clocked	No
Number of inputs	16
Number of outputs	16
Length of cable	
• Unshielded	max. 600 m
• Shielded	max. 1000 m
Voltages, Currents, Potentials	
Rated load voltage L+	24 VDC
Number of inputs that can be triggered simultaneously	
• Horizontal configuration	
Up to 40 °C	16
Up to 60 °C	8
• Vertical configuration	
Up to 40 °C	16
Total current of the outputs (per group)	
• Horizontal configuration	
Up to 40 °C	max. 4 A
Up to 60 °C	max. 3 A
• Vertical configuration	
Up to 40 °C	max. 2 A
Isolation	
• Between channels and backplane bus	Yes
• Between the channels	Yes
Inputs in groups of	16
Outputs in groups of	8
Permitted potential difference	
• Between the different circuits	75 VDC / 60 VAC
Insulation tested with	500 VDC
Current consumption	
• From the backplane bus	max. 80 mA
• From load voltage L+ (without load)	max. 80 mA
Power dissipation of the module	typ. 6.5 W

Status, Interrupts, Diagnostics	
Status display	Green LED per channel
Interrupts	None
Diagnostic functions	None
Data for Selecting a Sensor	
Input voltage	
• Rated value	24 VDC
• For signal "1"	13 to 30 V
• For signal "0"	-30 to + 5 V
Input current	
• At signal "1"	typ. 7 mA
Input delay	
• At "0" to "1"	1.2 to 4.8 ms
• At "1" to "0"	1.2 to 4.8 ms
Input characteristic curve	According to IEC 61131, type 1
Connection of Two-Wire BEROs	Possible
• Permitted bias current	max. 1.5 mA
Data for Selecting an Actuator	
Output voltage	
• At signal "1"	min. L + (-0.8 V)
Output current	
• At signal "1"	
Rated value	0.5 A
Permitted range	5 mA to 0.6 A
• At signal "0" (leakage current)	max. 0.5 mA
Output delay (for resistive load)	
• At "0" to "1"	max. 100 μs
• At "1" to "0"	max. 500 μs
Load resistor range	48 Ω to 4 kΩ
Lamp load	max. 5 W
Parallel connection of 2 outputs	
• For redundant triggering of a load	Possible (only outputs of the same group)
• To increase performance	Not possible
Triggering a digital input	Possible

Switch rate	
• For resistive load	max. 100 Hz
• Inductive load according to IEC 947-5-1, 13 DC	max. 0.5 Hz
• For lamp load	max. 10 Hz
Limit (internal) of the inductive circuit interruption voltage up	L + (-53 V), typ.
Short-circuit protection of the output	Yes, electronic
• Threshold on	1 A, typ.

3.32 Digital Input/Output Module SM 323; DI 8/DO 8 × 24 VDC/0.5 A; (6ES7 323-1BHx1-0AA0)

Order number: "Standard module"

6ES7 323-1BH01-0AA0

Order number: "SIMATIC Outdoor module"

6ES7 323-1BH81-0AA0

Characteristics

The SM 323; DI 8/DO 8 × 24 VDC/0.5 A features the following characteristics:

- 8 inputs, isolated in groups of 8
- 8 outputs, isolated in groups of 8
- 24 VDC rated input voltage
- 24 VDC rated load voltage
- Inputs suitable for switches and two / three / four-wire BEROs (proximity switches)
- Outputs suitable for solenoid valves, DC contactors and indicator lights

Using the module with high-speed counters

Please take note of the following information on the use of the module in connection with high-speed counters:

Note

When connecting the 24 V power supply via a mechanical contact, the outputs of the SM 323; DI 8/DO 8 × 24 VDC/0.5 A carry a "1" signal for approximately 50 μs for reasons associated with the circuitry.

**Terminal assignment and block diagram of the SM 323;
DI 8/DO 8 × 24 VDC/0.5 A**

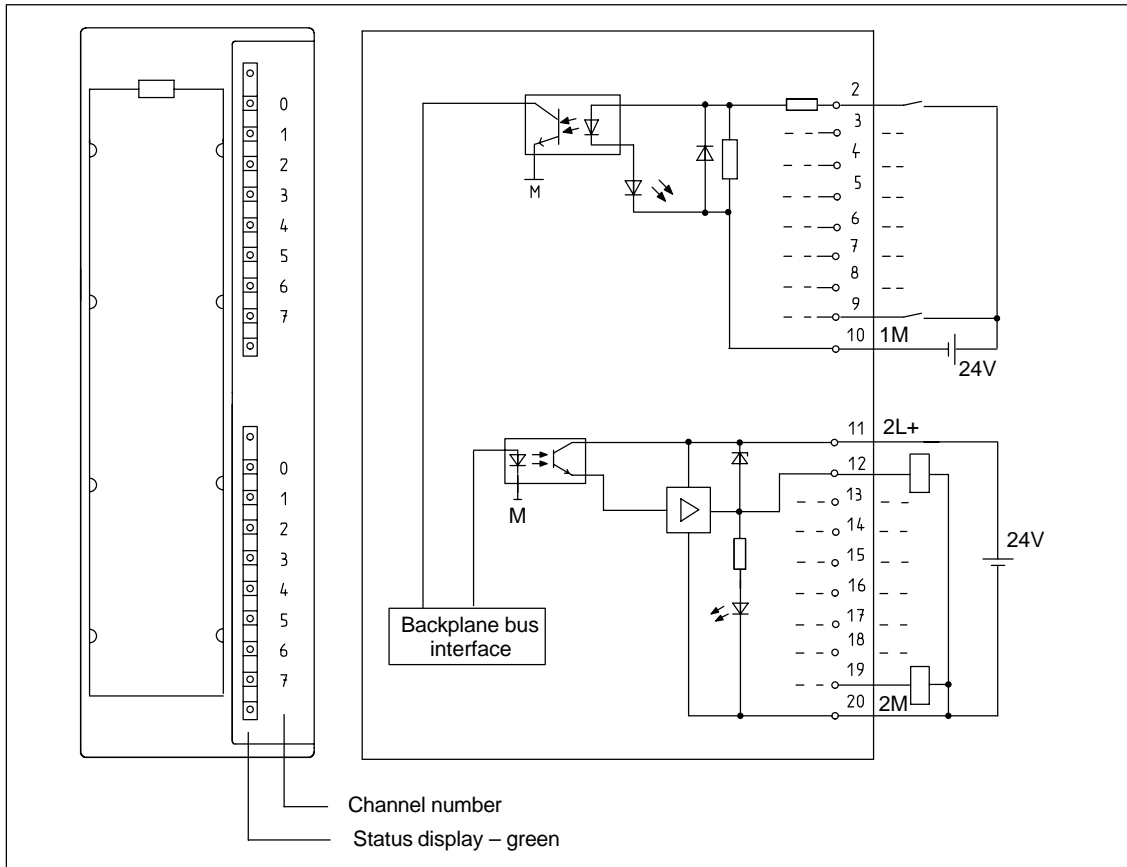

Figure 3-36 Module View and Block Diagram of Digital Input/Output Module SM 323;
DI 8/DO 8 × 24 VDC/0.5 A

Technical specifications of the SM 323; DI 8/DO 8 × 24 VDC/0.5 A

Dimensions and Weight		Status, Interrupts, Diagnostics	
Dimensions W × H × D (in millimeters)	40 × 125 × 117	Status display	Green LED per channel
Weight	Approx. 200 g	Interrupts	None
Data for Specific Module		Diagnostic functions	None
Supports clocked operation	No	Data for Selecting a Sensor	
Number of inputs	8	Input voltage	
Number of outputs	8	• Rated value	24 VDC
Length of cable		• For signal "1"	13 to 30 V
• Unshielded	max. 600 m	• For signal "0"	-30 to 5 V
• Shielded	max. 1000 m	Input current	
Voltages, Currents, Potentials		• At signal "1"	typ. 7 mA
Rated load voltage L+	24 VDC	Input delay	
Number of inputs that can be triggered simultaneously		• At "0" to "1"	1.2 to 4.8 ms
• Horizontal configuration Up to 60 °C	8	• At "1" to "0"	1.2 to 4.8 ms
• Vertical configuration Up to 40 °C	8	Input characteristic curve	According to IEC 61131, type 1
Total current of the outputs (per group)		Connection of Two-Wire BEROs	Possible
• Horizontal configuration Up to 60 °C	max. 4 A	• Permitted bias current	max. 1.5 mA
• Vertical configuration Up to 40 °C	max. 4 A		
Isolation			
• Between channels and backplane bus	Yes		
• Between the channels Inputs in groups of	Yes 8		
Outputs in groups of	8		
Permitted potential difference			
• Between the different circuits	75 VDC / 60 VAC		
Insulation tested with	500 VDC		
Current consumption			
• From the backplane bus	max. 40 mA		
• From load voltage L+ (without load)	max. 40 mA		
Power dissipation of the module	typ. 3.5 W		

Data for Selecting an Actuator			
Output voltage		Parallel connection of 2 outputs	
• At signal "1"	min. L + (-0.8 V)	• For redundant triggering of a load	Possible (only outputs of the same group)
Output current		• To increase performance	Not possible
• At signal "1"		Triggering a digital input	Possible
Rated value	0.5 A	Switch rate	
Permitted range	5 mA to 0.6 A	• For resistive load	max. 100 Hz
• At signal "0" (leakage current)	max. 0.5 mA	• Inductive load according to IEC 947-5-1, 13 DC	max. 0.5 Hz
Output delay (for resistive load)		• For lamp load	max. 10 Hz
• At "0" to "1"	max. 100 μ s	Limit (internal) of the inductive circuit interruption voltage up	L + (-53 V), typ.
• At "1" to "0"	max. 500 μ s	Short-circuit protection of the output	Yes, electronic
Load resistor range	48 Ω to 4 k Ω	• Threshold on	1 A, typ.
Lamp load	max. 5 W		

Analog Modules

Changes and improvements compared to the previous edition of the Reference Manual

This chapter describes all new analog modules. Furthermore, two new overview sections will make it easier for you to access the information:

- The "Module Overview" section shows you the modules that are available, together with their most important characteristics, and helps you quickly to find the module suitable for your task.
- The section entitled "Sequence of Steps from Choosing to Commissioning the Module" provides the answer to the question "What must I do in succession to commission the module quickly and successfully?"

Structure of the chapter

The present chapter is broken down into the following subjects:

1. Overview containing the modules that are available here and a description
2. Information that is generally available – in other words, affects all analog modules (such as parameter assignment and diagnostics)
3. Information that refers to specific modules (for example, characteristics, diagram of connections and block diagram, technical specifications and special characteristics of the module):
 - a) for analog input modules
 - b) for analog output modules
 - c) for analog input/output modules

STEP 7 blocks for analog functions

You can use the blocks FC 105 "SCALE" (Scale Values) and FC 106 "UNSCALE" (Unscale Values) for reading and outputting analog values in *STEP 7*. You will find the FCs in the standard library of *STEP 7* in the subdirectory called "TI-S7-Converting Blocks" (for a description refer to the *STEP 7* online Help for the FCs).

Additional information

Appendix A describes the structure of the parameter sets (data records 0, 1 and 128) in the system data. You must be familiar with this configuration if you want to modify the parameters of the modules in the *STEP 7* user program.

Appendix B describes the structure of the diagnostic data (data records 0 and 1) in the system data. You must be familiar with this configuration if you want to evaluate the diagnostic data of the modules in the *STEP 7* user program.

In this chapter

Section	Contents	Page
4.1	Module Overview	4-3
4.2	Sequence of Steps from Choosing to Commissioning the Analog Module	4-8
4.3	Analog Value Representation	4-10
4.4	Setting the Type of Measurement and Measuring Ranges of Analog Input Channels	4-31
4.5	Behavior of Analog Modules	4-34
4.6	Conversion, Cycle, Setting and Response Time of Analog Modules	4-39
4.7	Assigning Parameters to Analog Modules	4-43
4.8	Connecting Sensors/Transmitters to Analog Inputs	4-49
4.9	Connecting Voltage Sensors	4-54
4.10	Connecting Current Sensors	4-55
4.11	Connecting Resistance Thermometers and Resistors	4-57
4.12	Connecting Thermocouples	4-63
4.13	Connecting Loads/Actuators to Analog Outputs	4-72
4.14	Connecting Loads/Actuators to Voltage Outputs	4-73
4.15	Connecting Loads/Actuators to Current Outputs	4-76
4.16	Diagnostics of Analog Modules	4-77
4.17	Analog Module Interrupts	4-81
4.18	Analog Input Module SM 331; AI 8 × 16 bits; (6ES7 331-7NF00-0AB0)	4-83
4.19	Analog Input Module SM 331; AI 8 × 16 bits (6ES7 331-7NF10-0AB0)	4-92
4.20	Analog Input Module SM 331; AI 8 × 13 bits; (6ES7 331-1KF00-0AB0)	4-105
4.21	Analog Input Module SM 331; AI 8 × 12 bits; (6ES7 331-7KF02-0AB0)	4-111
4.22	Analog Input Module SM 331; AI 8 × RTD (6ES7 331-7PF00-0AB0)	4-122

Section	Contents	Page
4.23	Analog Input Module SM 331; AI 8 × TC (6ES7 331-7PF10-0AB0)	4-135
4.24	Analog Input Module SM 331; AI 2 × 12 bits; (6ES7 331-7KBx2-0AB0)	4-150
4.25	Analog Output Module SM 332; AO 8 × 12 bits (6ES7 332-5HF00-0AB0)	4-160
4.26	Analog Output Module SM 332; AO 4 × 16 bits; (6ES7 332-7ND01-0AB0)	4-166
4.27	Analog Output Module SM 332; AO 4 × 12 bits; (6ES7 332-5HD01-0AB0)	4-171
4.28	Analog Output Module SM 332; AO 2 × 12 bits; (6ES7 332-5HBx1-0AB0)	4-177
4.29	Analog Input/Output Module SM334; AI 4/AO 2 × 8/8 bits; (6ES7 334-0CE01-0AA0)	4-183
4.30	Analog Input/Output Module SM334; AI 4/AO 2 × 12 bits; (6ES7 334-0KE00-0AB0)	4-189

4.1 Module Overview

Introduction

The following tables summarize the most important characteristics of the analog modules. This overview is intended to make it easy to choose the suitable module for your task.

Table 4-1 Analog Input Modules: Characteristics at a Glance

Module Characteristics	SM 331; AI 8×16 bits (-7NF00-)	SM 331; AI 8×16 bits (-7NF10-)	SM 331; AI 8×13 bits (-1KF00-)	SM 331; AI 8×12 bits (-7KF02-)
Number of inputs	8 inputs in 4 channel groups	8 inputs in 4 channel groups	8 inputs in 8 channel groups	8 inputs in 4 channel groups
Resolution	Adjustable for each channel group: • 15 bits + sign	Adjustable for each channel group: • 15 bits + sign	Adjustable for each channel group: • 12 bits+sign	Adjustable for each channel group: • 9 bits+sign • 12 bits+sign • 14 bits+sign
Measuring method	Adjustable for each channel group: • Voltage • Current	Adjustable for each channel group: • Voltage • Current	Adjustable for each channel: • Voltage • Current • Resistors • Temperature	Adjustable for each channel group: • Voltage • Current • Resistors • Temperature
Selection of measuring range	Arbitrary, per channel group	Arbitrary, per channel group	Arbitrary, per channel	Arbitrary, per channel group
Supports clocked operation	No	No	No	No
Programmable diagnostics	Yes	Yes	No	Yes
Diagnostic interrupt	Adjustable	Adjustable	No	Adjustable
Limit value monitoring	Adjustable for 2 channels	Adjustable for 8 channels	No	Adjustable for 2 channels
Hardware interrupt upon limit violation	Adjustable	Adjustable	No	Adjustable
Hardware interrupt at end of cycle	No	Yes	No	No
Potential relationships	Galvanic isolation to: • CPU	Galvanic isolation to: • CPU	Galvanic isolation to: • CPU	Galvanic isolation to: • CPU • Load voltage (not for 2-DMU)
Permitted potential difference between the inputs (ECM)	50 VDC	60 VDC	2.0 VDC	2.5 VDC
Special features	—	-	—	—

Sign 2-DMU Sign Two-wire transmitter

Table 4-2 Analog input modules: Characteristics at a glance (continued)

Module Characteristics	SM 331; AI 8 × RTD (-7PF00-)	SM 331; AI 8 × TC (-7PF10-)	SM 331; AI 2 × 12 bits (-7KBx2-)
Number of inputs	8 inputs in 4 channel groups	8 inputs in 4 channel groups	2 inputs in 1 channel group
Resolution	Adjustable for each channel group: <ul style="list-style-type: none"> • 15 bits + sign 	Adjustable for each channel group: <ul style="list-style-type: none"> • 15 bits + sign 	Adjustable for each channel group: <ul style="list-style-type: none"> • 9 bits+sign • 12 bits+sign • 14 bits+sign
Measuring method	Adjustable for each channel group: <ul style="list-style-type: none"> • Resistors • Temperature 	Adjustable for each channel group: <ul style="list-style-type: none"> • Temperature 	Adjustable for each channel group: <ul style="list-style-type: none"> • Voltage • Current • Resistors • Temperature
Selection of measuring range	Arbitrary, per channel group	Arbitrary, per channel group	Arbitrary, per channel group
Programmable diagnostics	Yes	Yes	Yes
Supports clocked operation	No	No	No
Diagnostic Interrupt	Adjustable	Adjustable	Adjustable
Limit value monitoring	Adjustable for 8 channels	Adjustable for 8 channels	Adjustable for 1 channel
Hardware interrupt upon limit violation	Adjustable	Adjustable	Adjustable
Hardware interrupt at end of cycle	Adjustable	Adjustable	No
Potential relationships	Galvanic isolation to: <ul style="list-style-type: none"> • CPU 	Galvanic isolation to: <ul style="list-style-type: none"> • CPU 	Galvanic isolation to: <ul style="list-style-type: none"> • CPU • Load voltage (not for 2-DMU)
Permitted potential difference between the inputs (ECM)	75 VDC / 60 VAC	75 VDC / 60 VAC	2.5 VDC
Special features	—	—	—

Sign
2-DMUSign
Two-wire transmitter

Table 4-3 Analog Output Modules: Characteristics at a Glance

Module Characteristics	SM 332; AO 8 × 12 bits (-5HF00-)	SM 332; AO 4 × 16 bits (-7ND01-)	SM 332; AO 4 × 12 bits (-5HD01-)	SM 332; AO 2 × 12 bits (-5HBx1-)
Number of outputs	8 outputs in 8 channel groups	4 outputs in 4 channel groups	4 outputs in 4 channel groups	2 output in 2 channels groups
Resolution	12 bits	16 bits	12 bits	12 bits
Output type	Channel by channel: <ul style="list-style-type: none"> • Voltage • Current 	Channel by channel: <ul style="list-style-type: none"> • Voltage • Current 	Channel by channel: <ul style="list-style-type: none"> • Voltage • Current 	Channel by channel: <ul style="list-style-type: none"> • Voltage • Current
Supports clocked operation	No	Yes	No	No
Programmable diagnostics	Yes	Yes	Yes	Yes
Diagnostic interrupt	Adjustable	Adjustable	Adjustable	Adjustable
Substitute value output	No	Adjustable	Adjustable	Adjustable
Potential relationships	Galvanic isolation between: <ul style="list-style-type: none"> • CPU • Of the load voltage 	Galvanic isolation between: <ul style="list-style-type: none"> • CPU and channel • The channels • Output and L+, M • CPU and L+, M 	Galvanic isolation to: <ul style="list-style-type: none"> • CPU • Of the load voltage 	Galvanic isolation to: <ul style="list-style-type: none"> • CPU • Of the load voltage
Special features	–	–	–	–

Table 4-4 Analog Input/Output Modules: Characteristics at a Glance

Module Characteristics	SM 334; AI 4/AO 2 × 8/8 bits (-0CE01-)	SM 334; AI 4/AO 2 × 12 bits (-0KE00-)
Number of inputs	4 inputs in 1 channel group	4 inputs in 2 channel groups
Number of outputs	2 outputs in 1 channel group	2 outputs in 1 channel group
Resolution	8 bits	12 bits + sign
Measuring Method	Adjustable for each channel group: <ul style="list-style-type: none"> • Voltage • Current 	Adjustable for each channel group: <ul style="list-style-type: none"> • Voltage • Resistors • Temperature
Output type	Channel by channel: <ul style="list-style-type: none"> • Voltage • Current 	Channel by channel: <ul style="list-style-type: none"> • Voltage
Supports clocked operation	No	No
Programmable diagnostics	No	No
Diagnostic Interrupt	No	No
Limit value monitoring	No	No
Hardware interrupt upon limit violation	No	No
Hardware interrupt at end of cycle	No	No
Substitute value output	No	No
Potential relationships	<ul style="list-style-type: none"> • Non-isolated to CPU • Galvanic isolation to load voltage 	Galvanic isolation to: <ul style="list-style-type: none"> • CPU • Of the load voltage
Special features	Not parameterizable, setting of measurement and output type by means of wiring	–

4.2 Sequence of Steps from Choosing to Commissioning the Module

Introduction

The following table contains the tasks that you have to perform one after the other to commission analog modules successfully.

The sequence of steps is a suggestion, but you can perform individual steps either earlier or later (for example, assign parameters to the module) or install other modules or install, commission etc. other modules in between times.

Sequence of steps

Table 4-5 Sequence of Steps from Choosing to Commissioning the Analog Module

Step	Procedure	Refer to...
1.	Select the module	Section 4.1 and specific module section from Section 4.21
2.	With some analog input modules: set the measuring method and measuring range by means of the measuring range module	Section 4.4
3.	Install the module in the SIMATIC S7 network	"Mounting" section in the Installation Manual for the programmable logic controller being used: <ul style="list-style-type: none"> S7-300 Programmable Controllers, Hardware and Installation or S7-400, M7-400 Programmable Controllers, Hardware and Installation or
4.	Assign parameters to module	Section 4.7
5.	Connect measuring sensor or loads to module	Sections 4.8 to 4.15

Table 4-5 Sequence of Steps from Choosing to Commissioning the Analog Module, continued

Step	Procedure	Refer to...
6.	Commission configuration	"Commissioning" section in the Installation Manual for the programmable controller being used: <ul style="list-style-type: none">• S7-300 Programmable Controllers, Hardware and Installation or S7-400, M7-400 Programmable Controllers, Hardware and Installationor• ET 200M Distributed I/O Device
7.	If commissioning was not successful, diagnose configuration	Section 4.16

4.3 Analog Value Representation

Introduction

This section describes the analog values for all the measuring ranges and output ranges which you can use with the analog modules.

Converting analog values

The CPU processes the analog values in binary form only.

Analog input modules convert the analog process signal into digital form.

Analog output modules convert the digital output value into an analog signal.

Analog value representation with 16-bit resolution

The digitized analog value is the same for both input and output values having the same nominal range. The analog values are represented as a fixed-point number in two's complement. The resulting assignment is as follows:

Bit	15	14	13	12	11	10	9	8	7	6	5	4	3	2	1	0
Value of bits	2^{15}	2^{14}	2^{13}	2^{12}	2^{11}	2^{10}	2^9	2^8	2^7	2^6	2^5	2^4	2^3	2^2	2^1	2^0

Sign

The sign of the analog value is always contained in bit number 15:

- "0" → +
- "1" → -

Resolution less than 16 bits

If the resolution of an analog module has fewer than 16 bits, the analog value is stored left-justified on the module. The lower-order bit positions not used are padded with zeros ("0").

Example

In the following example you can see how the positions not padded with "0" are written for low resolution.

Table 4-6 Example: Bit Pattern of a 16-Bit and a 13-Bit Analog Value

Resolution	Analog value															
Bit	15	14	13	12	11	10	9	8	7	6	5	4	3	2	1	0
16-bit analog value	0	1	0	0	0	1	1	0	0	1	1	1	0	0	1	1
13-bit analog value	0	1	0	0	0	1	1	0	0	1	1	1	0	0	0	0

4.3.1 Analog Value Representation for Analog Input Channels**Introduction**

The tables in this chapter contain the measured value representations for the various measuring ranges of the analog input modules. The values in the tables apply to all modules with the corresponding measuring ranges.

Notes for readers of the tables

Tables 4-8 to 4-9 contain the binary representation of the measured values.

Since the binary representation of the measured values is always the same, starting at 4-10 these tables only contain the measured values and the units.

Measured-value resolution

The resolution of the analog values may differ, depending on the analog module and its parameterization. With resolutions < 15 bits, the bits indicated by "x" are set to "0".

Note: This resolution does not apply to temperature values. The converted temperature values are the result of a conversion in the analog module (see Tables 4-16 to 4-31).

Table 4-7 Possible Analog Value Resolutions

Resolution in bits (+ sign)	Units		Analog value	
	decimal	hexadecimal	High-order byte	Low-order byte
8	128	80 _H	Sign 0 0 0 0 0 0 0	1 x x x x x x x
9	64	40 _H	Sign 0 0 0 0 0 0 0	0 1 x x x x x x
10	32	20 _H	Sign 0 0 0 0 0 0 0	0 0 1 x x x x x
11	16	10 _H	Sign 0 0 0 0 0 0 0	0 0 0 1 x x x x
12	8	8 _H	Sign 0 0 0 0 0 0 0	0 0 0 0 1 x x x
13	4	4 _H	Sign 0 0 0 0 0 0 0	0 0 0 0 0 1 x x
14	2	2 _H	Sign 0 0 0 0 0 0 0	0 0 0 0 0 0 1 x
15	1	1 _H	Sign 0 0 0 0 0 0 0	0 0 0 0 0 0 0 1

Binary representation of the input ranges

The input ranges shown in Tables 4-8 to 4-9 are defined in two's complement representation:

Table 4-8 Bipolar Input Ranges

Units	Measured Value in %	Data Word																Range
		² ₁₅	² ₁₄	² ₁₃	² ₁₂	² ₁₁	² ₁₀	² ₉	² ₈	² ₇	² ₆	² ₅	² ₄	² ₃	² ₂	² ₁	² ₀	
32767	> 118.515	0	1	1	1	1	1	1	1	1	1	1	1	1	1	1	1	Overflow
32511	117.589	0	1	1	1	1	1	1	0	1	1	1	1	1	1	1	1	Overrange
27649	> 100.004	0	1	1	0	1	1	0	0	0	0	0	0	0	0	0	1	
27648	100.000	0	1	1	0	1	1	0	0	0	0	0	0	0	0	0	0	Rated range
1	0.003617	0	0	0	0	0	0	0	0	0	0	0	0	0	0	0	1	
0	0.000	0	0	0	0	0	0	0	0	0	0	0	0	0	0	0	0	
-1	-0.003617	1	1	1	1	1	1	1	1	1	1	1	1	1	1	1	1	
-27648	-100.000	1	0	0	1	0	1	0	0	0	0	0	0	0	0	0	0	
-27649	≤ -100.004	1	0	0	1	0	0	1	1	1	1	1	1	1	1	1	1	Under-range
-32512	-117.593	1	0	0	0	0	0	0	1	0	0	0	0	0	0	0	0	
-32768	≤ -117.596	1	0	0	0	0	0	0	0	0	0	0	0	0	0	0	0	Underflow

Table 4-9 Unipolar Input Ranges

Units	Measured Value in %	Data Word																Range
		² ₁₅	² ₁₄	² ₁₃	² ₁₂	² ₁₁	² ₁₀	² ₉	² ₈	² ₇	² ₆	² ₅	² ₄	² ₃	² ₂	² ₁	² ₀	
32767	≥ 118.515	0	1	1	1	1	1	1	1	1	1	1	1	1	1	1	1	Overflow
32511	117.589	0	1	1	1	1	1	1	0	1	1	1	1	1	1	1	1	Over-range
27649	≥ 100.004	0	1	1	0	1	1	0	0	0	0	0	0	0	0	0	1	
27648	100.000	0	1	1	0	1	1	0	0	0	0	0	0	0	0	0	0	Rated range
1	0.003617	0	0	0	0	0	0	0	0	0	0	0	0	0	0	0	1	
0	0.000	0	0	0	0	0	0	0	0	0	0	0	0	0	0	0	0	
-1	-0.003617	1	1	1	1	1	1	1	1	1	1	1	1	1	1	1	1	
-4864	-17.593	1	1	1	0	1	1	0	1	0	0	0	0	0	0	0	0	Under-range
-32768	≤ -17.596	1	0	0	0	0	0	0	0	0	0	0	0	0	0	0	0	Underflow

Analog Value Representation in Voltage Measuring Ranges

Table 4-10 Analog Value Representation in Voltage Measuring Ranges ± 10 V to ± 1 V

System			Voltage Measuring Range				
	Dec.	Hex.	± 10 V	± 5 V	± 2.5 V	± 1 V	
118.515 %	32767	7FFF	11.851 V	5.926 V	2.963 V	1.185 V	Overflow
117.593%	32512	7F00					
117.589%	32511	7EFF	11.759 V	5.879 V	2.940 V	1.176 V	Overrange
	27649	6C01					
100.000%	27648	6C00	10 V	5 V	2.5 V	1 V	Rated range
75.000 %	20736	5100	7.5 V	3.75 V	1.875 V	0.75 V	
0.003617%	1	1	361.7 μ V	180.8 μ V	90.4 μ V	36.17 μ V	
0 %	0	0	0 V	0 V	0 V	0 V	
	-1	FFFF					
-75.00 %	-20736	AF00	-7.5 V	-3.75 V	-1.875 V	-0.75 V	
-100.000%	-27648	9400	-10 V	-5 V	-2.5 V	-1 V	
	-27649	93FF					Underrange
-117.593%	-32512	8100	-11.759 V	-5.879 V	-2.940 V	-1.176 V	
-117.596 %	-32513	80FF					Underflow
-118.519%	-32768	8000	-11.851 V	-5.926 V	-2.963 V	-1.185 V	

Table 4-11 Analog Value Representation in Voltage Measuring Ranges ± 500 mV to ± 80 mV

System			Voltage Measuring Range			
	Dec.	Hex.	± 500 mV	± 250 mV	± 80 mV	
118.515 %	32767	7FFF	592.6 mV	296.3 mV	94.8 mV	Overflow
117.593%	32512	7F00				
117.589%	32511	7EFF	587.9 mV	294.0 mV	94.1 mV	Overrange
	27649	6C01				
100.000%	27648	6C00	500 mV	250 mV	80 mV	Rated range
75.00 %	20736	5100	375 mV	187.5 mV	60 mV	
0.003617%	1	1	18.08 μ V	9.04 μ V	2.89 μ V	
0 %	0	0	0 mV	0 mV	0 mV	
	-1	FFFF				
-75.00 %	-20736	AF00	-375 mV	-187.5 mV	-60 mV	
-100.000%	-27648	9400	-500 mV	-250 mV	-80 mV	
	-27649	93FF				Underrange
-117.593%	-32512	8100	-587.9 mV	-294.0 mV	-94.1 mV	
-117.596 %	-32513	80FF				Underflow
-118.519%	-32768	8000	-592.6 mV	-296.3 mV	-94.8 mV	

Table 4-12 Analog Value Representation in Voltage Measuring Ranges 1 to 5 V and 0 to 10V

System			Voltage Measuring Range		
	Dec.	Hex.	1 to 5 V	0 to 10 V	
118.515 %	32767	7FFF	5.741 V	11.852 V	Overflow
117.593%	32512	7F00			
117.589%	32511	7EFF	5.704 V	11.759 V	Overrange
	27649	6C01			
100.000%	27648	6C00	5 V	10 V	Rated range
75%	20736	5100	3.75 V	7.5 V	
0.003617%	1	1	1 V + 144.7 μ V	0 V + 361.7 μ V	
0 %	0	0	1 V	0 V	
	-1	FFFF			Underrange
-17.593%	-4864	ED00	0.296 V	Negative values not possible	
	-4865	ECFF			
≤ -17.596 %	-32768	8000			Underflow

Analog Value Representation in Current Measuring Ranges

Table 4-13 Analog Value Representation in Current Measuring Ranges ± 20 mA to ± 3.2 mA

System			Current Measuring Range			
	Dec.	Hex.	± 20 mA	± 10 mA	± 3.2 mA	
118.515 %	32767	7FFF	23.70 mA	11.85 mA	3.79 mA	Overflow
117.593%	32512	7F00				
117.589%	32511	7EFF	23.52 mA	11.76 mA	3.76 mA	Overrange
	27649	6C01				
100.000%	27648	6C00	20 mA	10 mA	3.2 mA	Rated range
75%	20736	5100	15 mA	7.5 mA	2.4 mA	
0.003617%	1	1	723.4 nA	361.7 nA	115.7 nA	
0 %	0	0	0 mA	0 mA	0 mA	
	-1	FFFF				
-75%	-20736	AF00	-15 mA	-7.5 mA	-2.4 mA	
-100.000%	-27648	9400	-20 mA	-10 mA	-3.2 mA	Underrange
	-27649	93FF				
-117.593%	-32512	8100	-23.52 mA	-11.76 mA	-3.76 mA	
-117.596 %	-32513	80FF				Underflow
-118.519%	-32768	8000	-23.70 mA	-11.85 mA	-3.79 mA	

Table 4-14 Analog Value Representation in Current Measuring Ranges 0 to 20 mA and 4 to 20 mA

System			Current Measuring Range		
	Dec.	Hex.	0 to 20 mA	4 to 20 mA	
118.515 %	32767	7FFF	23.70 mA	22.96 mA	Overflow
117.593%	32512	7F00			
117.589%	32511	7EFF	23.52 mA	22.81 mA	Overrange
	27649	6C01			
100.000%	27648	6C00	20 mA	20 mA	Rated range
75%	20736	5100	15 mA	15 mA	
0.003617%	1	1	723.4 nA	4 mA + 578.7 nA	
0 %	0	0	0 mA	4 mA	
	-1	FFFF			Underrange
-17.593%	-4864	ED00	-3.52 mA	1.185 mA	
	-4865	ECFF			Underflow
≤ -17.596 %	-32768	8000			

Analog Value Representation for Resistance-Type Transmitters

Table 4-15 Analog Value Representation for Resistance Type Transmitters from 10 k Ω and from 150 Ω to 600 Ω

System			Resistance-Type Transmitter Range				
	Dec.	Hex.	10 k Ω	150 Ω	300 Ω	600 Ω	
118.515 %	32767	7FFF	11.852k Ω	177.77 Ω	355.54 Ω	711.09 Ω	Overflow
117.593%	32512	7F00		150.01 Ω	300.01 Ω	600.02 Ω	
117.589%	32511	7EFF	11.759	176.38	352.77 Ω	705.53 Ω	Overrange
	27649	6C01					
100.000%	27648	6C00	10 k Ω	150 Ω	300 Ω	600 Ω	Rated range
75%	20736	5100	7.5 k Ω	112.5 Ω	225 Ω	450 Ω	
0.003617%	1	1	361.7m Ω	5.43 m Ω	10.85m Ω	21.70m Ω	
0 %	0	0	0 Ω	0 Ω	0 Ω	0 Ω	
			(neg. values physically not possible)				Underrange

Analog value representation for RTD Resistance Temperature Detectors Pt x00 standard

Table 4-16 Analog Value Representation for RTD Resistance Temperature Detectors Pt 100, 200, 500, 1000

Pt x00 standard in $^{\circ}\text{C}$ (1 digit =0.1 $^{\circ}\text{C}$)	Units		Pt x00 standard in $^{\circ}\text{F}$ (1 digit =0.1 $^{\circ}\text{F}$)	Units		Pt x00 standard in K (1 digit = 0.1 K)	Units		Range
	decim-al	hexa-decimal		decim-al	hexa-decimal		decim-al	hexa-decimal	
> 1000.0	32767	7FFF _H	> 1832.0	32767	7FFF _H	> 1273.2	32767	7FFF _H	Overflow
1000.0	10000	2710 _H	1832.0	18320	4790 _H	1273.2	12732	31BC _H	Overrange
:	:	:	:	:	:	:	:	:	
850.1	8501	2135 _H	1562.1	15621	3D05 _H	1123.3	11233	2BE1 _H	Rated range
850.0	8500	2134 _H	1562.0	15620	3D04 _H	1123.2	11232	2BE0 _H	
:	:	:	:	:	:	:	:	:	Underrange
-200.0	-2000	F830 _H	-328.0	-3280	F330 _H	73.2	732	2DC _H	
-200.1	-2001	F82F _H	-328.1	-3281	F32F _H	73.1	731	2DB _H	Underrange
:	:	:	:	:	:	:	:	:	
-243.0	-2430	F682 _H	-405.4	-4054	F02A _H	30.2	302	12E _H	Underflow
< -243.0	-32768	8000 _H	< -405.4	-32768	8000 _H	< 30.2	32768	8000 _H	

Analog value representation for RTD Resistance Temperature Detectors Pt x00 climate

Table 4-17 Analog Value Representation for RTD Resistance Temperature Detectors Pt 100, 200, 500, 1000

Pt x00 climate in °C (1 digit = 0.01°C)	Units		Pt x00 climate in °F (1 digit = 0.01 °F)	Units		Range
	decimal	hexa-decimal		decimal	hexa-decimal	
>155.00	32767	7FFF _H	>311.00	32767	7FFF _H	Overflow
155.00	15500	3C8C _H	311.00	31100	797C _H	Overrange
:	:	:	:	:	:	
130.01	13001	32C9 _H	266.01	26601	67E9 _H	
130.00	13000	32C8 _H	266.00	26600	67E8 _H	Rated range
:	:	:	:	:	:	
-120.00	-12000	D120 _H	-184.00	-18400	B820 _H	
-120.01	-12001	D11F _H	-184.01	-18401	B81F _H	Underrange
:	:	:	:	:	:	
-145.00	-14500	C75C _H	-229.00	-22900	A68C _H	
< -145.00	-32768	8000 _H	< -229.00	-32768	8000 _H	Underflow

Analog value representation for RTD Resistance Temperature Detectors Ni x00 standard

Table 4-18 Analog Value Representation for RTD Resistance Temperature Detectors Ni100, 120, 200, 500, 1000

Ni x00 standard in °C (1 digit = 0.1°C)	Units		Ni x00 standard in °F (1 digit = 0.1 °F)	Units		Ni x00 standard in K (1 digit = 0.1 K)	Units		Range
	decimal	hexa-decimal		decimal	hexa-decimal		decimal	hexa-decimal	
>295.0	32767	7FFF _H	>563.0	32767	7FFF _H	>568.2	32767	7FFF _H	Overflow
295.0	2950	B86 _H	563.0	5630	15FE _H	568.2	5682	1632 _H	Overrange
:	:	:	:	:	:	:	:	:	
250.1	2501	9C5 _H	482.1	4821	12D5 _H	523.3	5233	1471 _H	
250.0	2500	9C4 _H	482.0	4820	12D4 _H	523.2	5232	1470 _H	Rated range
:	:	:	:	:	:	:	:	:	
-60.0	-600	FDA8 _H	-76.0	-760	FD08 _H	213.2	2132	854 _H	
-60.1	-601	FDA7 _H	-76.1	-761	FD07 _H	213.1	2131	853 _H	Underrange
:	:	:	:	:	:	:	:	:	
-105.0	-1050	FBE6 _H	-157.0	-1570	F9DE _H	168.2	1682	692 _H	
< -105.0	-32768	8000 _H	< -157.0	-32768	8000 _H	<168.2	32768	8000 _H	Underflow

Analog value representation for RTD Resistance Temperature Detectors Ni x00 climate

Table 4-19 Analog Value Representation for RTD Resistance Temperature Detectors Ni 100, 120, 200, 500, 1000

Ni x00 climate in °C (1 digit = 0.01°C)	Units		Ni x00 climate in °F (1 digit = 0.01 °F)	Units		Range
	decim- al	hexa- decimal		decim- al	hexa- decimal	
> 295.00	32767	7FFF _H	>325.11	32767	7FFF _H	Overflow
295.00	29500	733C _H	327.66	32766	7FFE _H	Ovrrange
:	:	:	:	:	:	
250.01	25001	61A9 _H	280.01	28001	6D61 _H	Rated range
250.00	25000	61A8 _H	280.00	28000	6D60 _H	
:	:	:	:	:	:	Underrange
-60.00	-6000	E890 _H	-76.00	-7600	E250 _H	
-60.01	-6001	E88F _H	-76.01	-7601	E24F _H	Underflow
:	:	:	:	:	:	
-105.00	-10500	D6FC _H	-157.00	-15700	C2AC _H	
< -105.00	-32768	8000 _H	< -157.00	-32768	8000 _H	

Analog value representation for RTD Resistance Temperature Detectors Cu 10 standard

Table 4-20 Analog Value Representation for RTD Resistance Temperature Detectors Cu 10

Cu 10 standard in °C (1 digit = 0.01°C)	Units		Cu 10 standard in °F (1 digit = 0.01 °F)	Units		Cu 10 standard in K (1 digit = 0.01 K)	Units		Range
	decim- al	hexa- decimal		decim- al	hexa- decimal		decim- al	hexa- decimal	
> 312.0	32767	7FFF _H	>593.6	32767	7FFF _H	>585.2	32767	7FFF _H	Overflow
312.0	3120	C30 _H	593.6	5936	1730 _H	585.2	5852	16DC _H	Ovrrange
:	:	:	:	:	:	:	:	:	
260.1	2601	A29 _H	500.1	5001	12D5 _H	533.3	5333	14D5 _H	Rated range
260.0	2600	A28 _H	500.0	5000	1389 _H	533.2	5332	14D4 _H	
:	:	:	:	:	:	:	:	:	Underrange
-200.0	-2000	F830 _H	-328.0	-3280	F330 _H	73.2	732	2DC _H	
-200.1	-2001	F82F _H	-328.1	-3281	F32F _H	73.1	731	2DB _H	Underflow
:	:	:	:	:	:	:	:	:	
-240.0	-2400	F6A0 _H	-400.0	-4000	F060 _H	33.2	332	14C _H	
< -240.0	-32768	8000 _H	< -400.0	-32768	8000 _H	<33.2	32768	8000 _H	

Analog value representation for RTD Resistance Temperature Detectors Cu 10 climate

Table 4-21 Analog Value Representation for RTD Resistance Temperature Detectors Cu 10

Cu 10 climate in °C (1 digit = 0.01°C)	Units		Cu 10 climate in °F (1 digit = 0.01 °F)	Units		Range
	decim- al	hexa- decimal		decim- al	hexa- decimal	
> 180.00	32767	7FFF _H	>325.11	32767	7FFF _H	Overflow
180.00	18000	4650 _H	327.66	32766	7FFE _H	Overrange
:	:	:	:	:	:	
150.01	15001	3A99 _H	280.01	28001	6D61A _H	
150.00	15000	3A98 _H	280.00	28000	6D60 _H	Rated range
:	:	:	:	:	:	
-50.00	-5000	EC78 _H	-58.00	-5800	E958 _H	
-50.01	-5001	EC77 _H	-58.01	-5801	E957 _H	Underrange
:	:	:	:	:	:	
-60.00	-6000	E890 _H	-76.00	-7600	E250 _H	
< -60.00	-32768	8000 _H	< -76.00	-32768	8000 _H	Underflow

Analog value representation for thermocouples type B

Table 4-22 Analog Value Representation for Thermocouples Type B

Type B in °C	Units		Type B in °F	Units		Type B in K	Units		Range
	decim- al	hexa- decimal		decim- al	hexa- decimal		decim- al	hexa- decimal	
>2070.0	32767	7FFF _H	>3276.6	32767	7FFF _H	>2343.2	32767	7FFF _H	Overflow
2070.0	20700	50DC _H	3276.6	32766	7FFE _H	2343.2	23432	5B88 _H	Overrange
:	:	:	:	:	:	:	:	:	
1821.0	18210	4722 _H	2786.6	27866	6CDA _H	2094.2	20942	51CE _H	
1820.0	18200	4718 _H	2786.5	27865	6CD9 _H	2093.2	20932	51C4 _H	Rated range
:	:	:	:	:	:	:	:	:	
0.0	0	0000 _H	32.0	320	0140 _H	273.2	2732	0AAC _H	
:	:	:	:	:	:	:	:	:	Underrange
-120.0	-1200	FB50 _H	-184.0	-1840	F8D0 _H	153.2	1532	05FC _H	
< -120.0	-32768	8000 _H	< -184.0	-32768	8000 _H	<153.2	32768	8000 _H	Underflow

Analog Value Representation for Thermocouples type C

Table 4-23 Analog Value Representation for Thermocouples Type C

Type C in °C	Units		Type C in °F	Units		Range
	decim- al	hexa- decimal		decim- al	hexa- decimal	
>2500.0	32767	7FFF _H	>3276.6	32767	7FFF _H	Overflow
2500.0	25000	61A8 _H	3276.6	32766	7FFE _H	Ovrange
:	:	:	:	:	:	
2315.1	23151	5A6F _H	2786.6	27866	6CDA _H	
2315.0	23150	5A6E _H	2786.5	27865	6CD9 _H	Rated range
:	:	:	:	:	:	
0.0	0	0000 _H	32.0	320	0140 _H	
0.1	-1	FFFF _H	31.9	319	013F _H	Underrange
:	:	:	:	:	:	
-120.0	-1200	FB50 _H	-184.0	-1840	F8D0 _H	
< -120.0	-32768	8000 _H	< -184.0	-32768	8000 _H	Underflow

Analog Value Representation for Thermocouples type E

Table 4-24 Analog Value Representation for Thermocouples Type E

Type E in °C	Units		Type E in °F	Units		Type E in K	Units		Range
	decim- al	hexa- decimal		decim- al	hexa- decimal		decim- al	hexa- decimal	
> 1200.0	32767	7FFF _H	> 2192,0	32767	7FFF _H	> 1473.2	32767	7FFF _H	Overflow
1200.0	12000	2EE0 _H	2192.0	21920	55A0 _H	1473.2	14732	398C _H	Ovrange
:	:	:	:	:	:	:	:	:	
1000.1	10001	2711 _H	1833.8	18338	47A2 _H	1274.2	12742	31C6 _H	
1000.0	10000	2710 _H	1832.0	18320	4790 _H	1273.2	12732	31BC _H	Rated range
:	:	:	:	:	:	:	:	:	
-270.0	-2700	F574 _H	-454.0	-4540	EE44 _H	0	0	0000 _H	
< -270.0	< -2700	H	< -454.0	< -4540	<EE44 _H	<0	<0	<0000 _H	Underflow
In the case of incorrect wiring (e. g. polarity reversal or open inputs) or of a sensor error in the negative range (e. g. incorrect thermocouple type), the analog input module signals underflow ...									
... of F0C4 _H and outputs 8000 _H of FB70 _H and outputs 8000 _H of E5D4 _H and outputs 8000 _H .			

Analog Value Representation for Thermocouples type J

Table 4-25 Analog Value Representation for Thermocouples Type J

Type J in °C	Units		Type J in °F	Units		Type J in K	Units		Range
	decim- al	hexa- decimal		decim- al	hexa- decimal		decim- al	hexa- decimal	
> 1450.0	32767	7FFF _H	> 2642.0	32767	7FFF _H	> 1723.2	32767	7FFF _H	Overflow
1450.0	14500	38A4 _H	2642.0	26420	6734 _H	1723.2	17232	4350 _H	Overrange
:	:	:	:	:	:	:	:	:	
1201.0	12010	2EEA _H	2193.8	21938	55B2 _H	1474.2	14742	3996 _H	
1200.0	12000	2EE0 _H	2192.0	21920	55A0 _H	1473.2	14732	398C _H	Rated range
:	:	:	:	:	:	:	:	:	
-210.0	-2100	F7CC _H	-346.0	-3460	F27C _H	63.2	632	0278 _H	
< -210.0	< -2100	<F7CC _H	< -346.0	< -3460	<F27C _H	<63.2	< 632	< 0278 _H	Underflow
In the case of incorrect wiring (e. g. polarity reversal or open inputs) or of a sensor error in the negative range (e. g. incorrect thermocouple type), the analog input module signals underflow ...									
... of F31C _H and outputs 8000 _H of EA0C _H and outputs 8000 _H of FDC8 _H and outputs 8000 _H .			

Analog value representation for thermocouples type K

Table 4-26 Analog Value Representation for Thermocouples Type K

Type K in °C	Units		Type K in °F	Units		Type K in K	Units		Range
	decim- al	hexa- decimal		decim- al	hexa- decimal		decim- al	hexa- decimal	
> 1622.0	32767	7FFF _H	>2951.6	32767	7FFF _H	> 1895.2	32767	7FFF _H	Overflow
1622.0	16220	3F5C _H	2951.6	29516	734C _H	1895.2	18952	4A08 _H	Overrange
:	:	:	:	:	:	:	:	:	
1373.0	13730	35A2 _H	2503.4	25034	61CA _H	1646.2	16462	404E _H	
1372.0	13720	3598 _H	2501.6	25061	61B8 _H	1645.2	16452	4044 _H	Rated range
:	:	:	:	:	:	:	:	:	
-270.0	-2700	F574 _H	-454.0	-4540	EE44 _H	0	0	0000 _H	
< -270.0	< -2700	< F574 _H	< -454.0	< -4540	<EE44 _H	0 %	0 %	< 0000 _H	Underflow
In the case of incorrect wiring (e. g. polarity reversal or open inputs) or of a sensor error in the negative range (e. g. incorrect thermocouple type), the analog input module signals underflow ...									
... of F0C4 _H and outputs 8000 _H of E5D4 _H and outputs 8000 _H of FB70 _H and outputs 8000 _H .			

Analog value representation for thermocouples type L

Table 4-27 Analog Value Representation for Thermocouples Type L

Type L in °C	Units		Type L in °F	Units		Type L in K	Units		Range
	decim- al	hexa- decimal		decim- al	hexa- decimal		decim- al	hexa- decimal	
>1150.0	32767	7FFF _H	>2102.0	32767	7FFF _H	>1423.2	32767	7FFF _H	Overflow
1150.0	11500	2CEC _H	2102.0	21020	521C _H	1423.2	14232	3798 _H	Overrange
:	:	:	:	:	:	:	:	:	
901.0	9010	2332 _H	1653.8	16538	409A _H	1174.2	11742	2DDE _H	
900.0	9000	2328 _H	1652.0	16520	4088 _H	1173.2	11732	2DD4 _H	Rated range
:	:	:	:	:	:	:	:	:	
-200.0	-2000	F830 _H	-328.0	-3280	F330 _H	73.2	732	02DC _H	
< -200.0	< -2000	< F830 _H	< -328.0	< -3280	< F330 _H	< 73.2	< 732	< 02DC _H	Underflow
In the case of incorrect wiring (e. g. polarity reversal or open inputs) or of a sensor error in the negative range (e. g. incorrect thermocouple type), the analog input module signals underflow ...									
... of F380 _H and outputs 8000 _H of EAC0 _H and outputs 8000 _H of FE2C _H and outputs 8000 _H .			

Analog Value Representation for Thermocouples type N

Table 4-28 Analog Value Representation for Thermocouples Type N

Type N in °C	Units		Type N in °F	Units		Type N in K	Units		Range
	decim- al	hexa- decimal		decim- al	hexa- decimal		decim- al	hexa- decimal	
> 1550.0	32767	7FFF _H	>2822.0	32767	7FFF _H	> 1823.2	32767	7FFF _H	Overflow
1550.0	15500	3C8C _H	2822.0	28220	6E3C _H	1823.2	18232	4738 _H	Overrange
:	:	:	:	:	:	:	:	:	
1300.1	13001	32C9 _H	2373.8	23738	5CBA _H	1574.2	15742	3D7E _H	
1300.0	13000	32C8 _H	2372.0	23720	5CA8 _H	1573.2	15732	3D74 _H	Rated range
:	:	:	:	:	:	:	:	:	
-270.0	-2700	F574 _H	-454.0	-4540	EE44 _H	0	0	0000 _H	
< -270.0	< -2700	< F574 _H	< -454.0	< -4540	< EE44 _H	0 %	< 0	< 0000 _H	Underflow
In the case of incorrect wiring (e. g. polarity reversal or open inputs) or of a sensor error in the negative range (e. g. incorrect thermocouple type), the analog input module signals underflow ...									
... of F0C4 _H and outputs 8000 _H of E5D4 _H and outputs 8000 _H of FB70 _H and outputs 8000 _H .			

Analog Value Representation for Thermocouples type R, S

Table 4-29 Analog Value Representation for Thermocouples Type R, S

Types R, S in °C	Units		Types R, S in °F	Units		Types R, S in K	Units		Range
	decim- al	hexa- decimal		decim- al	hexa- decimal		decim- al	hexa- decimal	
>2019.0	32767	7FFF _H	>3276.6	32767	7FFF _H	>2292.2	32767	7FFF _H	Overflow
2019.0	20190	4EDE _H	3276.6	32766	7FFE _H	2292.2	22922	598A _H	Ovrange
:	:	:	:	:	:	:	:	:	
1770.0	17770	4524 _H	3218.0	32180	7DB4 _H	2043.2	20432	4FD0 _H	
1769.0	17690	451A _H	3216.2	32162	7DA2 _H	2042.2	20422	4FC6 _H	Rated range
:	:	:	:	:	:	:	:	:	
-50.0	-500	FE0C _H	-58.0	-580	FDBC _H	223.2	2232	08B8 _H	
-51.0	-510	FE02 _H	-59.8	-598	FDA A _H	222.2	2222	08AE _H	Underrange
:	:	:	:	:	:	:	:	:	
-170.0	-1700	F95C _H	-274.0	-2740	F54C _H	103.2	1032	0408 _H	
< -170.0	-32768	8000 _H	< -274.0	-32768	8000 _H	< 103-2	< 1032	8000 _H	Underflow

Analog Value Representation for Thermocouples type T

Table 4-30 Analog Value Representation for Thermocouples Type T

Type T in °C	Units		Type T in °F	Units		Type T in K	Units		Range
	decim- al	hexa- decimal		decim- al	hexa- decimal		decim- al	hexa- decimal	
>540.0	32767	7FFF _H	>1004.0	32767	7FFF _H	>813.2	32767	7FFF _H	Overflow
540.0	5400	1518 _H	1004.0	10040	2738 _H	813.2	8132	1FC4 _H	Ovrange
:	:	:	:	:	:	:	:	:	
401.0	4010	0FAA _H							
400.0	4000	0FA0 _H	752.0	7520	1D60 _H	673.2	6732	1AAC _H	Rated range
:	:	:	:	:	:	:	:	:	
-270.0	-2700	F574 _H	-454.0	-4540	EE44 _H	3.2	32	0020 _H	
< -270.0	< -2700	<F574 _H	< -454.0	< -4540	<EE44 _H	<3.2	< 32	< 0020 _H	Underflow
In the case of incorrect wiring (e. g. polarity reversal or open inputs) or of a sensor error in the negative range (e. g. incorrect thermocouple type), the analog input module signals underflow ...									
... of F0C4 _H and outputs 8000 _H of E5D4 _H and outputs 8000 _H of FB70 _H and outputs 8000 _H .			

Analog Value Representation for Thermocouples type U

Table 4-31 Analog Value Representation for Thermocouples Type U

Type U in °C	Units		Type U in °F	Units		Type U in K	Units		Range
	deci- mal	hexa- decimal		deci- mal	hexa- decimal		deci- mal	hexa- decimal	
>850.0	32767	7FFF _H	>1562.0	32767	7FFF _H	>1123.2	32767	7FFF _H	Overflow
850.0	8500	2134 _H	1562.0	15620	2738.0 _H	1123.2	11232	2BE0 _H	Overrange
:	:	:	:	:	:	:	:	:	
601.0	6010	177A _H	1113.8	11138	2B82 _H	874.2	8742	2226 _H	
600.0	6000	1770 _H	1112.0	11120	2B70 _H	873.2	8732	221C _H	Rated range
:	:	:	:	:	:	:	:	:	
-200.0	-2000	F830 _H	-328.0	-3280	F330 _H	73.2	732	02DC _H	
< -200.0	< -2000	<F830 _H	< -328.0	< -3280	<F330 _H	<73.2	< 732	<02DC _H	Underflow
In the case of incorrect wiring (e. g. polarity reversal or open inputs) or of a sensor error in the negative range (e. g. incorrect thermocouple type), the analog input module signals underflow ...									
... of F380 _H and outputs 8000 _H of EAC0 _H and outputs 8000 _H of FE2C _H and outputs 8000 _H .			

4.3.2 Analog Value Representation for Analog Output Channels

Introduction

The tables in this chapter contain the analog value representation for output channels of the analog output modules. The values in the tables apply to all modules with the corresponding output ranges.

Notes for readers of the tables

Tables 4-32 to 4-33 contain the binary representation of the output values.

Since the binary representation of the output values is always the same, starting at 4-34 these tables only contain the output ranges and the units.

Output ranges for the SM 334; AI 4/AO 2 × 8/8 bits

The analog input/output module SM 334; AI 4/AO 2 × 8/8 bits has output ranges from 0 to 10 V and from 0 to 20 mA. Unlike the other analog modules, the SM 334 has a lower resolution, however. Please note that the SM 334; AI 4/AO 2 × 8/8 bits with product status 1 does not have overranges.

Binary representation of the output ranges

The output ranges shown in Tables 4-32 to 4-33 are defined in two's complement representation:

Table 4-32 Bipolar Output Ranges

Units	Output Value in %	Data Word																Range
		2 ¹⁵	2 ¹⁴	2 ¹³	2 ¹²	2 ¹¹	2 ¹⁰	2 ⁹	2 ⁸	2 ⁷	2 ⁶	2 ⁵	2 ⁴	2 ³	2 ²	2 ¹	2 ⁰	
≥32512	0 %	0	1	1	1	1	1	1	1	x	x	x	x	x	x	x	x	Overflow
32511	117.589	0	1	1	1	1	1	1	0	1	1	1	1	1	1	1	1	Over-range
27649	≥100.004	0	1	1	0	1	1	0	0	0	0	0	0	0	0	0	1	
27648	100.000	0	1	1	0	1	1	0	0	0	0	0	0	0	0	0	0	Rated range
1	0.003617	0	0	0	0	0	0	0	0	0	0	0	0	0	0	0	1	
0	0.000	0	0	0	0	0	0	0	0	0	0	0	0	0	0	0	0	
-1	-0.003617	1	1	1	1	1	1	1	1	1	1	1	1	1	1	1	1	
-27648	-100.000	1	0	0	1	0	1	0	0	0	0	0	0	0	0	0	0	
-27649	≤100.004	1	0	0	1	0	0	1	1	1	1	1	1	1	1	1	1	Under-range
-32512	-117.593	1	0	0	0	0	0	0	1	0	0	0	0	0	0	0	0	
≤32513	0 %	1	0	0	0	0	0	0	0	x	x	x	x	x	x	x	x	Underflow

Table 4-33 Unipolar Output Ranges

Units	Output Value in %	Data Word																Range
		2 ¹⁵	2 ¹⁴	2 ¹³	2 ¹²	2 ¹¹	2 ¹⁰	2 ⁹	2 ⁸	2 ⁷	2 ⁶	2 ⁵	2 ⁴	2 ³	2 ²	2 ¹	2 ⁰	
≥32512	0 %	0	1	1	1	1	1	1	1	x	x	x	x	x	x	x	x	Overflow
32511	117.589	0	1	1	1	1	1	1	0	1	1	1	1	1	1	1	1	Overrange
27649	≥100.004	0	1	1	0	1	1	0	0	0	0	0	0	0	0	0	1	
27648	100.000	0	1	1	0	1	1	0	0	0	0	0	0	0	0	0	0	Rated range
1	0.003617	0	0	0	0	0	0	0	0	0	0	0	0	0	0	0	1	
0	0.000	0	0	0	0	0	0	0	0	0	0	0	0	0	0	0	0	
-1	0.000	1	1	1	1	1	1	1	1	1	1	1	1	1	1	1	1	
-32512		1	0	0	0	0	0	0	1	0	0	0	0	0	0	0	0	
≤32513	0 %	1	0	0	0	0	0	0	0	x	x	x	x	x	x	x	x	Underflow

Analog value representation in voltage output ranges

Table 4-34 Analog Value Representation in Output Range ± 10 V

System			Voltage Output Range	
	Dec.	Hex.	± 10 V	
118.5149%	32767	7FFF	0.00 V	Overflow, off circuit and de-energized
	32512	7F00		
117.589%	32511	7EFF	11.76 V	Overrange
	27649	6C01		
100 %	27648	6C00	10 V	Rated range
75%	20736	5100	7.5 V	
0.003617%	1	1	361.7 μ V	
0 %	0	0	0 V	
	-1	FFFF	-361.7 μ V	
-75 %	-20736	AF00	-7.5 V	
-100 %	-27648	9400	-10 V	Underrange
	-27649	93FF		
-117.593%	-32512	8100	-11.76 V	
	-32513	80FF		Underflow, off circuit and de-energized
-118.519%	-32768	8000	0.00 V	

Table 4-35 Analog Value Representation in Output Ranges 0 to 10 V and 1 to 5 V

System			Voltage Output Range		
	Dec.	hex.	0 to 10 V	1 to 5 V	
118.5149%	32767	7FFF	0.00 V	0.00 V	Overflow, off circuit and de-energized
	32512	7F00			
117.589%	32511	7EFF	11.76 V	5.70 V	Overrange
	27649	6C01			
100 %	27648	6C00	10 V	5 V	Rated range
75%	20736	5100	7.5 V	3.75 V	
0.003617%	1	1	361.7 μ V	1V+144.7 μ V	
0 %	0	0	0 V	1 V	
	-1	FFFF			Underrange
-25 %	-6912	E500		0 V	
	-6913	E4FF			Not possible. The output value is limited to 0 V.
-117.593%	-32512	8100			
	-32513	80FF			Underflow, off circuit and de-energized
-118.519%	-32768	8000	0.00 V	0.00 V	

Analog value representation in current output ranges

Table 4-36 Analog Value Representation in Output Range ± 20 mA

System			Current Output Range	
	Dec.	Hex.	± 20 mA	
118.5149%	32767	7FFF	0.00 mA	Overflow, off circuit and de-energized
	32512	7F00		
117.589%	32511	7EFF	23.52 mA	Overrange
	27649	6C01		
100 %	27648	6C00	20 mA	Rated range
75%	20736	5100	15 mA	
0.003617%	1	1	723.4 nA	
0 %	0	0	0 mA	
	-1	FFFF	-723.4 nA	
-75 %	-20736	AF00	-15 mA	
-100 %	-27648	9400	-20 mA	Underrange
	-27649	93FF		
-117.593%	-32512	8100	-23.52 mA	
	-32513	80FF		Underflow, off circuit and de-energized
-118.519%	-32768	8000	0.00 mA	

Table 4-37 Analog Value Representation in Output Ranges 0 and 20 mA and 4 to 20 mA

System			Current Output Range		
	Dec.	Hex.	0 to 20 mA	4 to 20 mA	
118.5149%	32767	7FFF	0.00 mA	0.00 mA	Overflow, off circuit and de-energized
	32512	7F00			
117.589%	32511	7EFF	23.52 mA	22.81 mA	Overrange
	27649	6C01			
100 %	27648	6C00	20 mA	20 mA	Rated range
75%	20736	5100	15 mA	15 mA	
0.003617%	1	1	723.4 nA	4mA+578.7 nA	
0 %	0	0	0 mA	4 mA	
	-1	FFFF			Underrange
-25 %	-6912	E500		0 mA	
	-6913	E4FF			Not possible. The output value is limited to 0 mA.
-117.593%	-32512	8100			
	-32513	80FF			Underflow, off circuit and de-energized
-118.519%	-32768	8000	0.00 mA	0.00 mA	

4.4 Setting the Measuring Method and Measuring Ranges of Analog Input Channels

Two procedures

There are two procedures for setting the measuring method and the measuring ranges of the analog input channels of the analog modules:

- With measuring range module and *STEP 7*
- By means of wiring the analog input channel and *STEP 7*

Which of these two methods is used for the individual analog modules depends on the module and is described in detail in the specific module sections.

The procedure for setting the measuring method and measuring range of the module in *STEP 7* is described in Section 4.7.

The following section describes how you set the measuring method and the measuring range by means of measuring range modules.

Setting the measuring method and the measuring ranges with measuring range modules

If the analog modules have measuring range modules, they are supplied with the measuring range modules plugged in.

If necessary, the measuring range modules must be replugged to change the measuring method and the measuring range.

Note

Make sure that the measuring range modules are on the side of the analog input module.

Before installing the analog input module, therefore, check whether the measuring range modules have to be set to another measuring method and another measuring range.

Possible settings for the measuring range modules

The measuring range modules can be set to the following positions: "A", "B", "C" and "D".

Which measuring range module positions you must select for the individual measuring methods and measuring ranges is described in detail in the specific module section.

The settings for the various types of measurement and measuring ranges are also printed on the analog module.

Replugging measuring range modules

If you want to replug a measuring range module, perform the following steps:

1. Use a screwdriver to ease the measuring range module out of the analog input module.

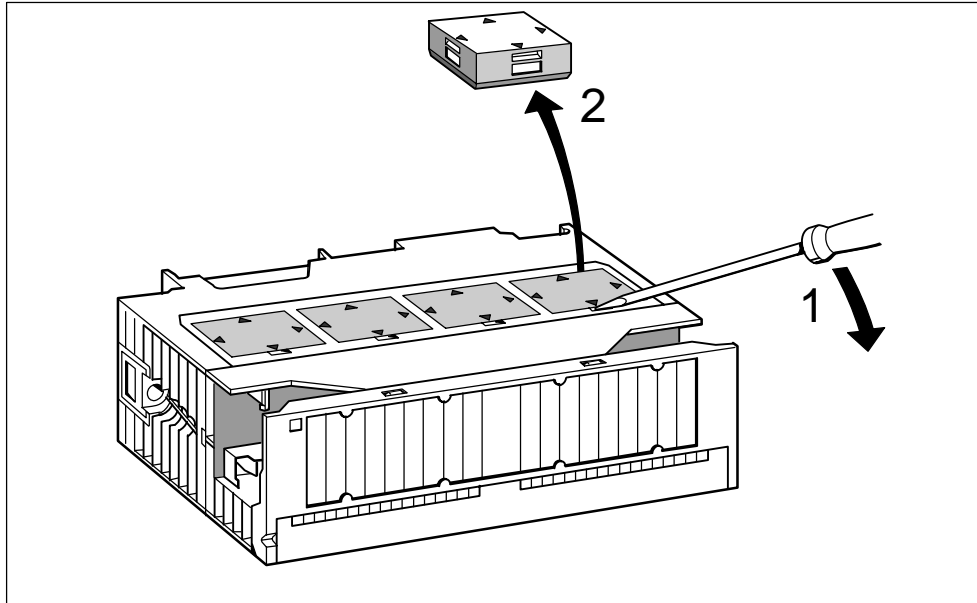

Figure 4-1 Easing Measuring Range Modules from the Analog Input Module

2. Insert the measuring range module (correctly positioned (1)) into the analog input module.

The measuring range selected is the one that points to marker point on module (2).

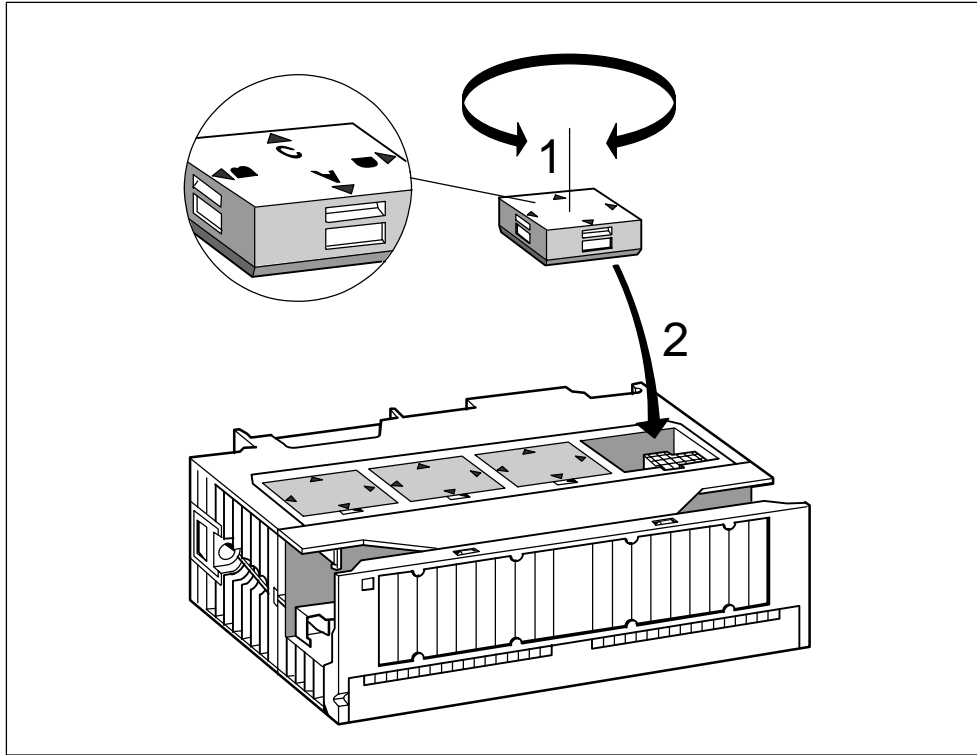

Figure 4-2 Inserting Measuring Range Modules into the Analog Input Module

Perform the same steps for all other measuring range modules.

The next step is to install the module.



Caution

If you have not set the measuring range modules correctly, the module may be destroyed.

Make sure that the measuring range module is in the correct position before connecting a sensor to the module.

4.5 Behavior of the Analog Modules

Introduction

In this section, you will find information on:

- How the analog input and output values depend on the operating states of the CPU and the supply voltage of the analog module
- The behavior of the analog modules depending on where the analog values lie within the value range
- The effect of the operational limit of the analog module on the analog input and output value, as illustrated by an example

4.5.1 Effect of Supply Voltage and Operating Mode

Effect of supply voltage and operating mode on the modules

The input and output values of the analog modules depend on the operating state of the CPU and on the supply voltage of the module.

Table 4-38 Dependencies of the Analog Input/Output Values on the Operating State of the CPU and the Supply Voltage L+

CPU Operating State		Supply Voltage L+ at Analog Module	Input Value of the Analog Input Module	Output Value of the Analog Output Module
POWER ON	RUN	L+ present	Measured value 7FFF _H until first conversion following power-up or after parameter assignment of the module has been completed	CPU values Until the first conversion... <ul style="list-style-type: none"> • after power-up has been completed, a signal of 0 mA or 0 V is output. • after parameter assignment has been completed, the previous value is output.
		L+ missing	Overflow value	0 mA/0 V
POWER ON	STOP	L+ present	Measured value 7FFF _H until first conversion following power-up or after parameter assignment of the module has been completed	Substitute value/last value (default values: 0 mA/0 V)
		L+ missing	Overflow value	0 mA/0 V
POWER OFF	–	L+ present	–	0 mA/0 V
		L+ missing	–	0 mA/0 V

Behavior on failure of the supply voltage

Failure of the supply voltage of the analog modules is always indicated by the SF LED on the module. Furthermore, this information is made available on the module (entry in diagnostic buffer).

Triggering of the diagnostic interrupt depends on the parameter assignment (see Section 4.7).

4.5.2 Effect of Range of Values of the Analog Values

Effect of errors on analog modules with diagnostics capability

Any errors that occur can lead to a diagnostics entry and a diagnostic interrupt with analog modules with diagnostics capability and corresponding parameter assignment. You will find the errors that might be involved in Section 4.16.

Effect of range of values on the analog input module

The behavior of the analog modules depends on where the input values lie within the range of values.

Table 4-39 Behavior of the Analog Input Modules as a Function of the Position of the Analog Value within the Range of Values

Measured Value In	Input Value	SF LED	Diagnostics	Interrupt
Rated range	Measured value	–	–	–
Ovrange/underrange	Measured value	–	–	–
Overflow	7FFF _H	Flashes ¹	Entered ¹	Diagnostic interrupt ¹
Underflow	8000 _H	Flashes ¹	Entered ¹	Diagnostic interrupt ¹
Beyond the programmed limit	Measured value	–	–	Hardware interrupt ¹

¹⁾ Only for modules with diagnostics capability and depending on parameter assignment

Effect of range of values on the analog output module

The behavior of the analog modules depends on where the output values lie within the value range.

Table 4-40 Behavior of the Analog Output Modules as a Function of the Position of the Analog Value within the Range of Values

Process Value Lies Within	Output Value	SF LED	Diagnostics	Interrupt
Rated range	CPU value	–	–	–
Ovrange/underrange	CPU value	–	–	–
Overflow	0 signal	–	–	–
Underflow	0 signal	–	–	–

4.5.3 Effect of Operational Limit and Basic Error Limit

Operational limit

The operational limit is the measuring error or output error of the analog module over the entire temperature range authorized for the module, referred to the rated range of the module.

Basic error limit

The basic error limit is the operational limit at 25 °C, referred to the rated range of the module.

Note

The percentage details of operational and basic error limits in the technical specifications of the module always refer to the **highest possible** input and output value in the rated range of the module.

Example of determination of the output error of a module

An analog output module SM 332; AO 4 × 12 bits is being used for voltage output. The output range from "0 to 10 V" is being used. The module is operating at an ambient temperature of 30 °C. Thus the operational limit applies. The technical specifications of the module state:

- Operational limit for voltage output: $\pm 0.5\%$

An output error, therefore, of $\pm 0.05\text{ V}$ ($\pm 0.5\%$ of 10 V) over the whole rated range of the module must be expected.

This means that with an actual voltage of, say, 1 V, a value in the range from 0.95 V to 1.05 V is output by the module. The relative error is $\pm 5\%$ in this case.

The figure below shows for the example how the relative error becomes increasingly less the more the output value approximates to the end of the rated range of 10 V.

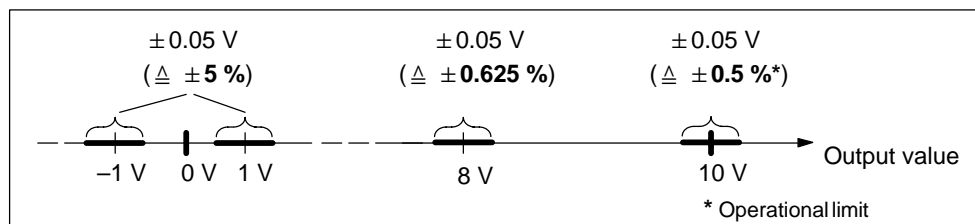

Figure 4-3 Example of the Relative Error of an Analog Output Module

4.6 Conversion, Cycle, Setting and Response Time of Analog Modules

Conversion time of analog input channels

The conversion time consists of a basic conversion time and additional processing times of the module for:

- Resistance test
- Wire-break monitoring

The basic conversion time depends directly on the conversion method of the analog input channel (integrating method, instantaneous value conversion).

In the case of integrating conversion methods, the integration time has a direct influence on the conversion time. The integration time depends on the interference frequency suppression that you set in *STEP 7* (refer to Section 4.7.1).

For the basic conversion times and additional processing times of the different analog modules refer to the technical specifications of the module concerned, starting at Section 4.21.

Scan time of analog input channels

Analog-to-digital conversion and the transfer of the digitized measured values to the memory and/or to the bus backplane are performed sequentially – in other words, the analog input channels are converted one after the other. The scan time – in other words, the time elapsing until an analog input value is again converted, is the sum of the conversion times of all activated analog input channels of the analog input module.

The following figure illustrates the components of the scan time for an n-channel analog module.

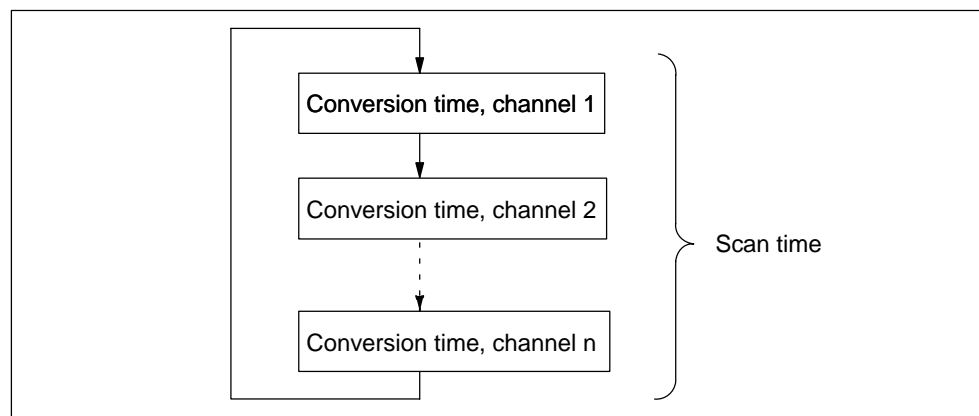

Figure 4-4 Scan Time of an Analog Input or Output Module

Conversion and scan times for analog input channels in channel groups

When the analog input channels are grouped in channel groups, you must take into account the conversion time channel group by channel group.

Example

Two analog input channels of the analog input module SM 331; AI 2×12 bits are combined to form a channel group. You must therefore grade the scan time in steps of 2.

Setting smoothing of analog values

You can set the smoothing of the analog values in *STEP 7* for some analog input modules.

Using smoothing

Smoothing of analog values ensures a stable analog signal for further processing.

It makes sense to smooth the analog values with slow variations of measured values – for example, with temperature measurements.

Smoothing principle

The measured values are smoothed by digital filtering. Smoothing is accomplished by the module calculating average values from a defined number of converted (digitized) analog values.

The user assigns parameters to smoothing at not more than four levels (none, low, average, high). The level determines the number of analog signals used for averaging.

The higher the smoothing level chosen, the more stable is the smoothed analog value and the longer it takes until the smoothed analog signal is applied after a step response (refer to the following example).

Example

The following figure shows the number of module cycles for a step response after which the smoothed analog value is approximately 100% applied, as a function of the smoothing that has been set. The figure applies to every change of signal at the analog input.

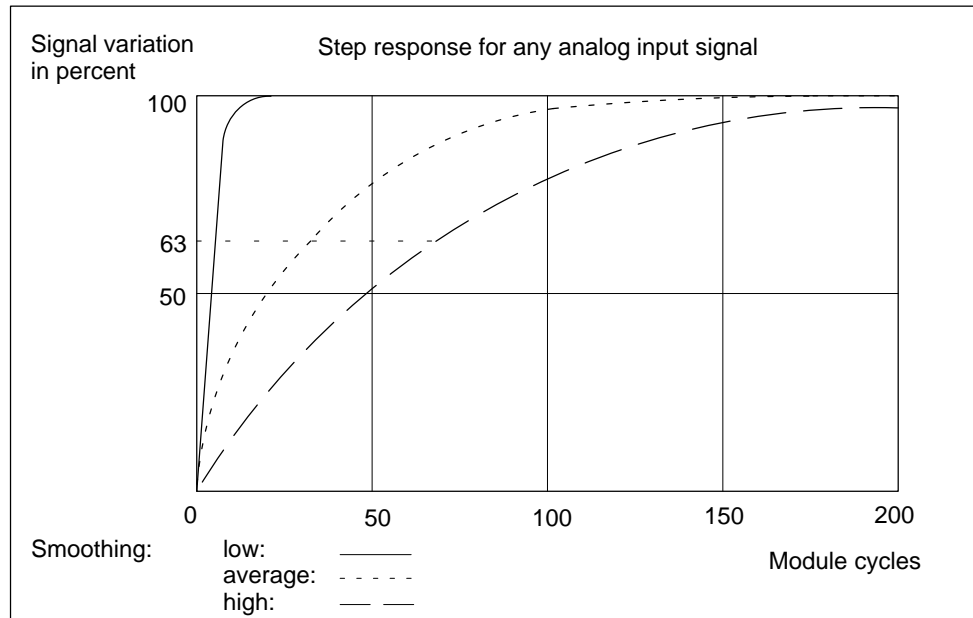

Figure 4-5 Example of the Influence of Smoothing on the Step Response

Additional information on smoothing

Refer to the specific section on the analog input module (from Section 4.21) to determine whether smoothing can be set for the specific module and for any special features that have to be taken into account.

Conversion time of the analog output channels

The conversion time of the analog output channels comprises the transfer of the digitized output values from the internal memory and the digital-to-analog conversion.

Scan time of analog output channels

The analog output channels are converted sequentially – in other words, the analog output channels are converted one after the other.

The scan time – in other words, the time elapsing until an analog output value is again converted, is the sum of the conversion times of all activated analog output channels (refer to 4-4).

Tip

You should disable any analog channels that are not being used to reduce the scan time in *STEP 7*.

Overview of the settling time and response time of the analog output modules

Figure 4-6 Settling and Response times of the Analog Output Channels

Settling time

The settling time (t_2 to t_3) – in other words, the time elapsing from application the converted value until the specified value is reached at the analog output – is load-dependent. A distinction is made between resistive, capacitive and inductive loads.

For the settling times of the different analog output modules as a function of load refer to the technical specifications of the module concerned, starting at Section 4.27.

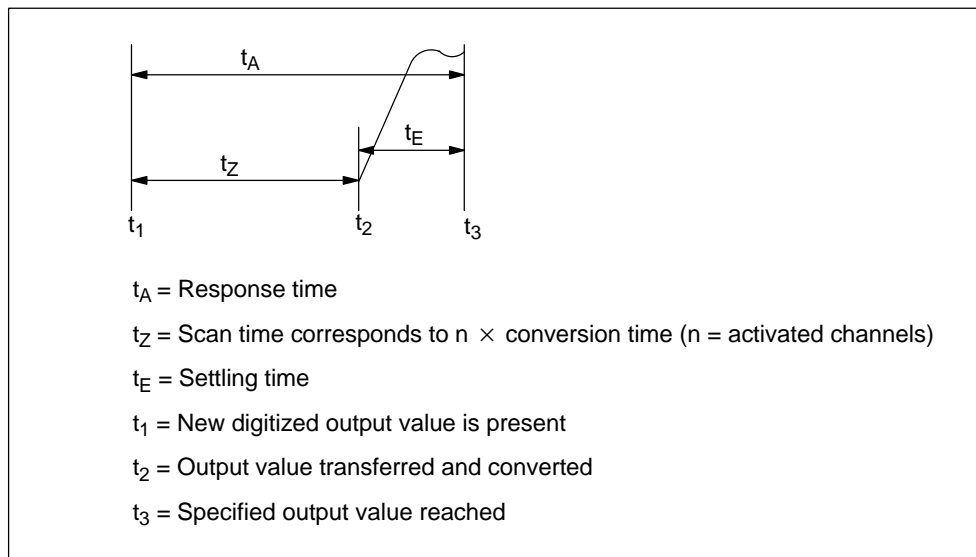
Response time

The response time (t_1 to t_3) – in other words, the time elapsing from application of the digital output values in the internal memory until the specified value is reached at the analog output – in a worst case scenario is the sum of the scan time and the settling time.

You have a worst case situation, if, shortly prior to the transfer of a new output value, the analog channel has been converted and is not converted again until all other channels are converted (scan time).

4.7 Analog Module Parameter Assignment

Introduction

Analog modules can have different characteristics. You can set the characteristics of the modules by means of parameter assignment.

Tools for parameter assignment

You assign parameters to analog modules with *STEP 7*. You must perform parameter assignment in STOP mode of the CPU.

When you have set all the parameters, download the parameters from the programming device to the CPU. On a transition from STOP to → RUN mode, the CPU then transfers the parameters to the individual analog modules.

In addition, if necessary you must place the measuring range modules of the module in the necessary position (refer to Section 4.4).

Static and dynamic parameters

The parameters are divided into static and dynamic parameters.

Set the static parameters in STOP mode of the CPU, as described above.

You can similarly modify the dynamic parameters in the current user program by means of SFCs. Note, however, that after a change from RUN → STOP, STOP → RUN of the CPU, the parameters set in *STEP 7* apply again. You will find a description of the parameter assignment of modules in the user program in Appendix A.

Parameter	Settable with	CPU Operating State
Static	PG (STEP7 HWCONFIG)	STOP
Dynamic	PG (STEP7 HWCONFIG)	STOP
	SFC 55 in the user program	RUN

4.7.1 Parameters of the Analog Input Modules

The analog input modules use a subset of the parameters and ranges of values listed in the table below, depending on the functionality. Refer to the section on the module concerned, starting from Section 4.21, for the subset "mastered" by the specific analog modules.

The default settings apply if you have not performed parameter assignment in *STEP 7*.

Table 4-41 Parameters of the Analog Input Modules

Parameter	Value Range	Default Settings	Parameter Type	Scope
Enable <ul style="list-style-type: none"> • Diagnostic interrupt • Hardware interrupt upon limit violation • Hardware interrupt at end of cycle 	Yes/no Yes/no Yes/no	No No No	Dynamic	Module
Trigger for hardware interrupt <ul style="list-style-type: none"> • Upper limit value • Lower limit value 	Constraint possible due to measuring range 32511 to -32512 -32512 to 32511	–	Dynamic	Channel or Channel group
Diagnostics <ul style="list-style-type: none"> • Group diagnostics • With wire-break check 	Yes/no Yes/no	No No	Static	Channel or Channel group

Table 4-41 Parameters of the Analog Input Modules, continued

Parameter	Value Range	Default Settings	Parameter Type	Scope
Measurement				
<ul style="list-style-type: none"> Measuring method 	Deactivated U Voltage 4DMU Current (4-wire transmitter) 2DMU Current (2-wire transmitter) R-4L Resistance (four-conductor connection) R-3L Resistance (three-conductor connection) RTD-4L Bulb resistor (linear, four-conductor connection) RTD-3L Bulb resistor (linear, three-conductor connection) TC-I ¹⁾ Thermocouple (internal comparison) TC-E ¹⁾ Thermocouple (external comparison) TC-IL ²⁾ Thermocouple (linear, internal comparison) TC-EL ²⁾ Thermocouple (linear, external comparison) TC-L00C ²⁾ Thermocouple (linear, reference temp. 0 °C) TC-L50C ²⁾ Thermocouple (linear, reference temp. 50°C)	U	Dynamic	Channel or Channel group
<ul style="list-style-type: none"> Measuring range 	For the settable measuring ranges of the input channels, please refer to the individual module description.	± 10 V		
<ul style="list-style-type: none"> Reaction with open thermocouple 	Overflow; underflow	Overflow		
<ul style="list-style-type: none"> Temperature unit³⁾ 	Degrees Celsius; degrees Fahrenheit; degrees Kelvin	Degrees Celsius	Dynamic	Module
<ul style="list-style-type: none"> Module filtering mode 	8 channels hardware filter 8 channels software filter 4 channels hardware filter	8 channels , hardware filter	Dynamic	Module

Table 4-41 Parameters of the Analog Input Modules, continued

Parameter	Value Range	Default Settings	Parameter Type	Scope
<ul style="list-style-type: none"> Temperature coefficient for temperature measurement with bulb resistor (RTD) 	Platinum (Pt) 0.00385 $\Omega/\Omega/^\circ\text{C}$ 0.003916 $\Omega/\Omega/^\circ\text{C}$ 0.003902 $\Omega/\Omega/^\circ\text{C}$ 0.003920 $\Omega/\Omega/^\circ\text{C}$ 0.003851 $\Omega/\Omega/^\circ\text{C}$ Nickel (Ni) 0.00618 $\Omega/\Omega/^\circ\text{C}$ 0.00672 $\Omega/\Omega/^\circ\text{C}$ Copper (Cu) 0.00427 $\Omega/\Omega/^\circ\text{C}$	0.00385	Dynamic	Channel or channel group
<ul style="list-style-type: none"> Interference frequency suppression 	400/60/50 Hz; 400 Hz; 60 Hz; 50 Hz; 10 Hz	50 Hz	Dynamic	Channel or channel group
<ul style="list-style-type: none"> Smoothing 	None Low Average High	None	Dynamic	Channel or Channel group

- 1) The module supplies a decimal value of the measured thermal voltage to the CPU – for example, 27648 at 80 mV (refer to Table 4-11)
- 2) The module supplies a temperature value to the CPU – for example, 120°C (refer to Table 4-17)
- 3) 1 digit = 0.1 °C; 1 digit = 0.1 °F

4.7.2 Parameters of the Analog Output Modules

The analog output modules use a subset of the parameters and ranges of values listed in the table below, depending on the functionality. Refer to the section on the module concerned, starting from Section 4.27, for the subset "mastered" by the specific analog modules.

The default settings apply if you have not performed parameter assignment in *STEP 7*.

Table 4-42 Parameters of the Analog Output Modules

Parameter	Value Range	Default Settings	Parameter Type	Scope
Enable <ul style="list-style-type: none"> Diagnostic interrupt 	Yes/no	No	Dynamic	Module
Diagnostics <ul style="list-style-type: none"> Group diagnostics 	Yes/no	No	Static	Channel
Output <ul style="list-style-type: none"> Output type Output range 	Deactivated Voltage Current For the settable measuring ranges of the output channels, please refer to the individual module description.	U $\pm 10\text{ V}$	Dynamic	Channel
Response with CPU-STOP	ASS Outputs de-energized LWH Hold last value EWS Apply substitute value	ASS	Dynamic	Channel

4.7.3 Parameters of the Analog Input/Output Modules

The analog input/output modules make available the parameters in the following table. The default settings apply if you have not performed parameter assignment in *STEP 7*.

Table 4-43 Parameters of the Analog Input/Output Modules

Parameter	Value Range	Default Settings	Parameter Type	Scope
Input Measurement • Measuring method • Measuring range • Integration time	Deactivated U Voltage R-4L Resistance (four-conductor connection) RTD-4L Bulb resistor (linear, four-conductor connection)	RTD-4L Pt 100 climate 20 ms	Dynamic	Channel
Output • Output type • Output range	Deactivated Voltage 0 to 10 V	U 0 to 10 V	Dynamic	Channel

4.8 Connecting Sensors to Analog Inputs

Introduction

You can connect different sensors to the analog input modules depending on the measuring method; voltage and current sensors, and resistors.

This section contains general information that is generally applicable to all the connection options for sensors described in the sections that follow.

Cables for analog signals

To reduce electrical interference, you should use twisted-pair shielded cables for the analog signals. The shield of the analog signal cables should be grounded at both cable ends.

If there are potential differences between the cable ends, an equipotential bonding current can flow over the shield, which leads to an interference of the analog signals. In such a case, you should ground the shield at one end of the cable only.

Isolated analog input modules

With the isolated analog input modules there is no electrical connection between the reference point of the measuring circuit M_{ANA} and the M terminal of the CPU.

You must use isolated analog input modules if a potential difference U_{ISO} can occur between the reference point of the measuring circuit M_{ANA} and the M terminal of the CPU. By means of an equipotential bonding conductor between the M_{ANA} terminal and the M terminal of the CPU, make sure that U_{ISO} does not exceed the permitted value.

Non-isolated analog input modules

With the non-isolated analog input modules, you must establish a connection between the reference point of the measuring circuit M_{ANA} and the M terminal of the CPU. Establish IM 153. For this purpose, connect the M_{ANA} terminal with the M terminal of the CPU and IM 153. A potential difference between M_{ANA} and the M terminal of the CPU and the IM 153 can result in corruption of the analog signal.

Limited potential difference U_{CM}

Only a limited potential difference U_{CM} (common mode voltage) may occur between the measuring lines M– of the input channels and the reference point of the measuring circuit M_{ANA} . In order to prevent the permissible value from being exceeded, you must take different actions, described below, depending on the potential connection of the sensors.

Abbreviations and mnemonics used in the figures below

The abbreviations and mnemonics used in the figures below have the following meanings:

- M +: Measuring lead (positive)
- M-: Measuring lead (negative)
- M_{ANA}: Reference potential of the analog measuring circuit
- M: Ground terminal
- L +: Terminal for 24 VDC supply voltage
- U_{CM}: Potential difference between inputs and reference potential of the M_{ANA} measuring circuit
- U_{ISO}: Potential difference between M_{ANA} and M terminal of CPU

Connecting isolated measuring sensors

Isolated sensors are not connected with the local ground potential (local ground). They can be operated free of potential.

With isolated sensors, potential differences might arise between the different sensors. These potential differences can arise as a result of interference or the local distribution of the sensors.

To prevent the permissible value for U_{CM} being exceeded when they are used in environments with a high level of EMC interference, we advise you to link M- with M_{ANA}.

You can operate the CPU in Grounded mode (refer to the figure below) or Ungrounded mode.

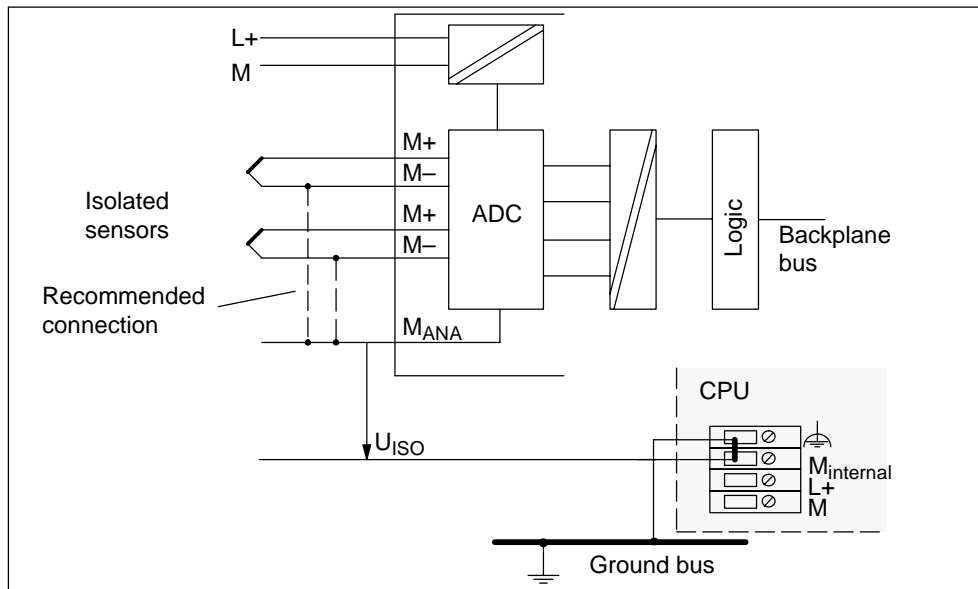

Figure 4-7 Connecting Isolated Sensors to an Isolated AI

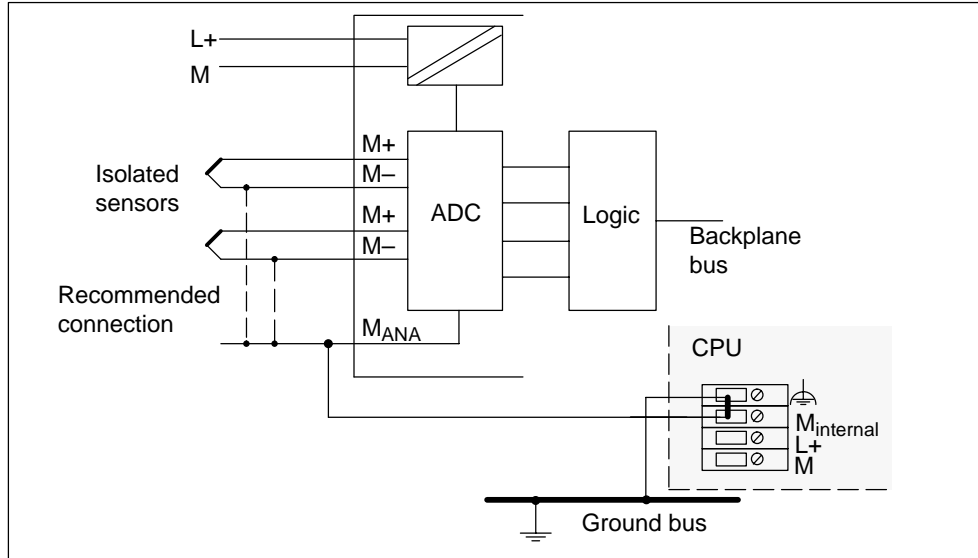

Figure 4-8 Connecting Isolated Sensors to a Non-Isolated AI

Note

Do not connect M- to M_{ANA} when connecting 2-wire transmitters for current measurement and resistance-type sensors. This also applies to inputs which are not used.

Non-isolated sensors

The non-isolated sensors are connected with the local ground potential (local ground). When using non-isolated sensors, you must connect M_{ANA} to the local ground.

Connecting non-isolated sensors

Caused by local conditions or interferences potential differences U_{CM} (static or dynamic) can occur between the locally distributed individual measuring points. If the potential difference U_{CM} exceeds the permissible value, you must provide equipotential bonding conductors between the measuring points.

When connecting non-isolated sensors to optically isolated modules, you can operate the CPU in Grounded mode (refer to the figure below) or Ungrounded mode.

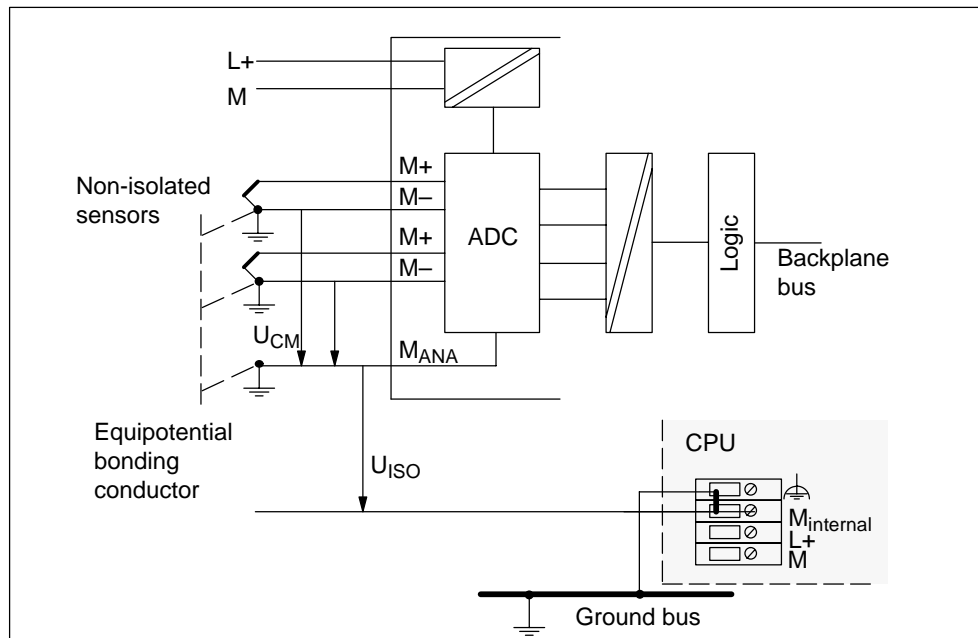

Figure 4-9 Connecting Non-Isolated Sensors to an Isolated AI

When connecting non-isolated sensors to non-isolated modules, you can operate the CPU only in Grounded mode.

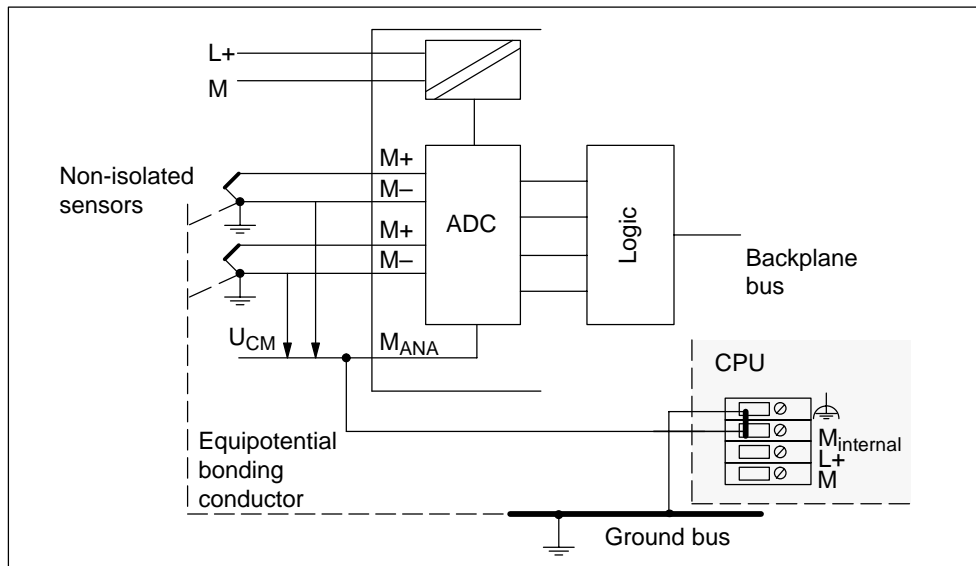

Figure 4-10 Connecting non-isolated sensors to a non-isolated AI

Note

You must not use non-isolated two-wire transmitters and non-isolated resistance-type sensors with a non-isolated AI!

4.9 Connecting Voltage Sensors

Note

The necessary connecting cables, which result from the potential connection of the analog input module and the sensors, are not drawn in the figures shown below.

In other words, you must continue to take note of and implement Section 4.8 with its generally valid information for connecting sensors.

Abbreviations and mnemonics used in the figure below

The abbreviations and mnemonics used in the figure below have the following meanings:

- M +: Measuring lead (positive)
- M -: Measuring lead (negative)
- M_{ANA}: Reference potential of the analog measuring circuit
- M : Ground terminal
- L +: Terminal for 24 VDC supply voltage

Connection of voltage sensors

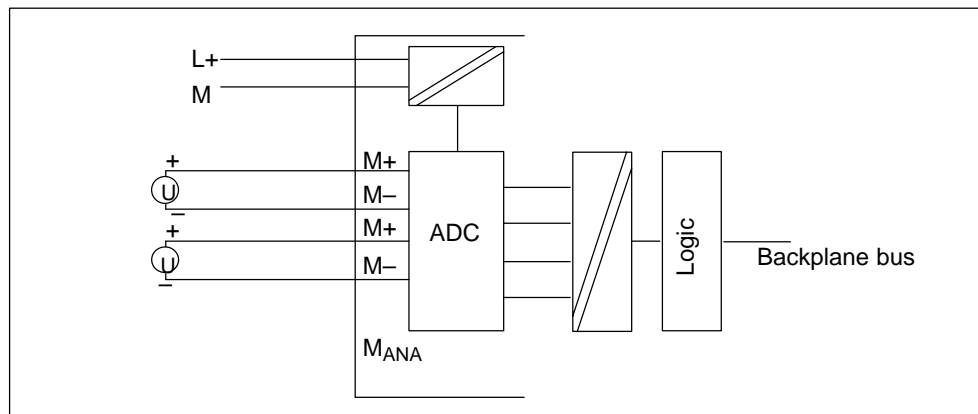

Figure 4-11 Connecting Voltage Sensors to an Isolated AI

4.10 Connecting Current Sensors

Note

The necessary connecting cables, which result from the potential connection of the analog input module and the sensors, are not drawn in the figures shown below.

In other words, you must continue to take note of and implement Section 4.8 with its generally valid information for connecting sensors.

Abbreviations and mnemonics used in the figures below

The abbreviations and mnemonics used in the figures below have the following meanings:

- M +: Measuring lead (positive)
- M -: Measuring lead (negative)
- M_{ANA}: Reference potential of the analog measuring circuit
- M : Ground terminal
- L +: Terminal for 24 VDC supply voltage

Supply voltage of the sensors

The 2-wire transmitter receives its short-circuit-proof power supply via the terminals of the analog input module.

This transmitter then converts the measured variable into a current. Two-wire transmitters must be isolated sensors.

Four-wire transmitters have separate power supplies.

Connecting 2-wire transmitters

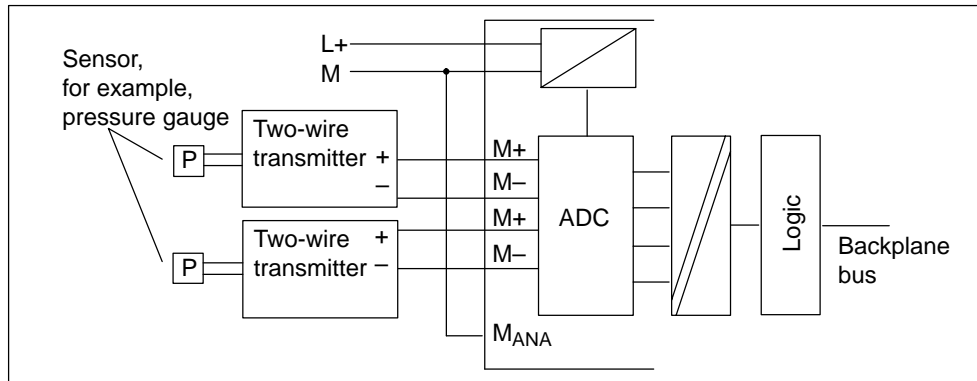

Figure 4-12 Connecting Two-Wire Transmitters to an Isolated AI

When the supply voltage L+ is fed from the module, you must assign parameters to the two-wire transmitter as a four-wire transmitter in *STEP 7*.

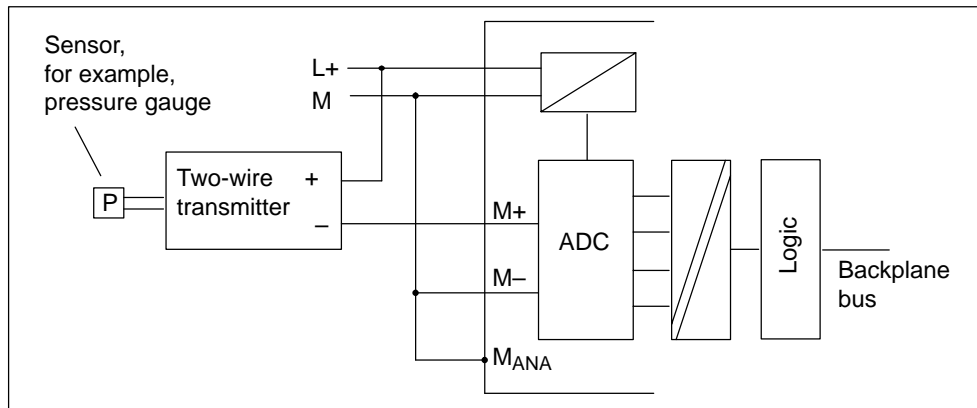

Figure 4-13 Connecting Two-Wire Transmitters Supplied from L+ to an Isolated AI

Connecting four-wire transmitters

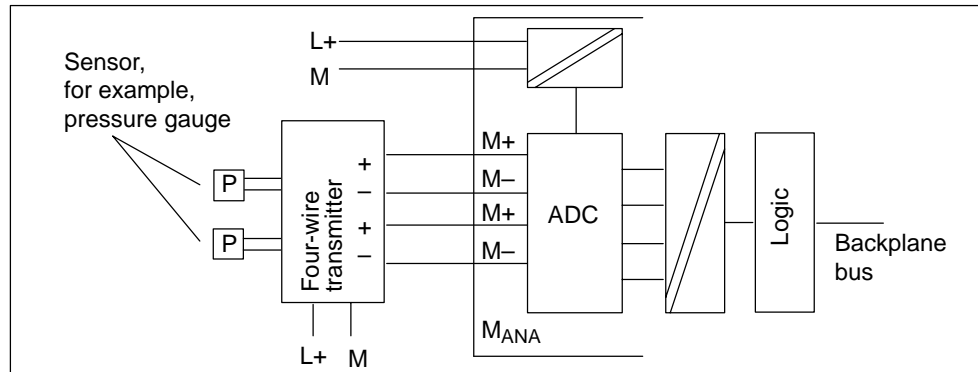

Figure 4-14 Connecting Four-Wire Transmitters to an Isolated AI

4.11 Connecting Resistance Thermometers and Resistors

Note

The necessary connecting cables, which result from the potential connection of the analog input module and the sensors, are not drawn in the figures shown below.

In other words, you must continue to take note of and implement Section 4.8 with its generally valid information for connecting sensors.

Abbreviations and mnemonics used in the figures below

The abbreviations and mnemonics used in the figures below have the following meanings:

- I_{C+} : Constant-current lead (positive)
- I_{C-} : Constant-current lead (negative)
- M_+ : Measuring lead (positive)
- M_- : Measuring lead (negative)
- M_{ANA} : Reference potential of the analog measuring circuit
- M : Ground terminal
- L_+ : Terminal for 24 VDC supply voltage
- S_- : Detector lead (negative)

Connecting resistance thermometers and resistors

The resistance thermometers/resistors are wired in a four-conductor, three-conductor or two-conductor connection.

With four-conductor and three-conductor connections, the module supplies a constant current via terminals I_{C+} and I_{C-} so that the potential drop occurring on the measuring cables is compensated. It is important that the connected constant current cables are directly connected to the resistance thermometer/resistor.

Measurements with four-conductor or three-conductor connections supply a more precise measuring result due to compensation than measurements with a two-conductor connection.

Four-conductor connection of a resistance thermometer

The voltage generated at the resistance thermometer is measured via the M_+ and M_- terminals. When you connect, watch out for the polarity of the connected cable (connect I_{C+} and M_+ as well as I_{C-} and M_- to the resistance thermometer).

When connecting, make sure that the connected cables **I_{C+} and M_+** and the cables **I_{C-} and M_-** are connected directly to the resistance thermometer.

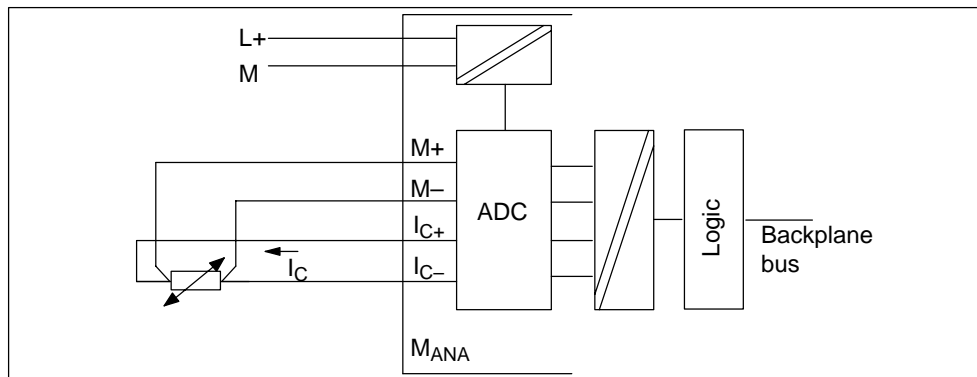

Figure 4-15 Four-conductor connection of resistance thermometers to an isolated AI

Three-conductor connection of a resistance thermometer

With a three-conductor connection on modules with four terminals, you must normally insert a **jumper between M_- and I_{C-}** (refer to Figure 4-16). Take note of the exception for the SM 331; AI $8 \times$ RTD (refer to Figure 4-18).

When connecting, make sure that the connected cables **I_{C+} and M_+** are connected directly to the resistance thermometer.

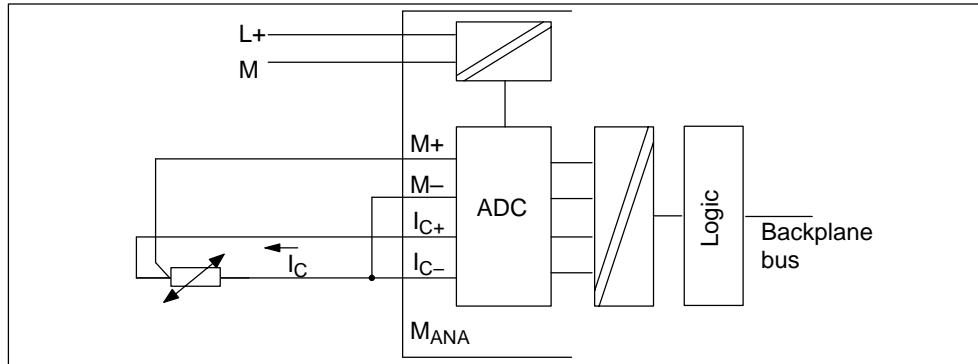

Figure 4-16 Three-Conductor Connection of Resistance Thermometers to an Isolated AI

Two-conductor connection of a resistance thermometer

With a two-conductor connection, you must insert jumpers on the module between M_+ and I_{C+} and between M_- and I_{C-} .

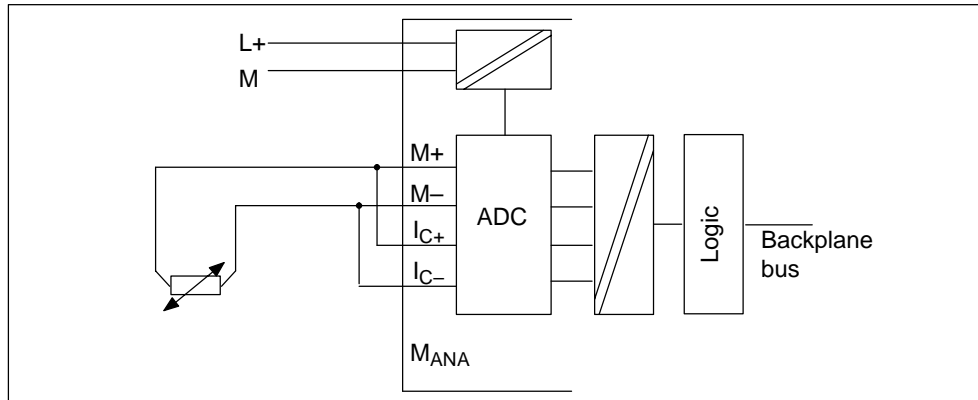

Figure 4-17 Two-Conductor Connection of Resistance Thermometers to an Isolated AI

Three-conductor connection to the SM 331; AI 8 × RTD

With a three-conductor connection to the SM 331; AI 8 × RTD you must insert a **jumper between M_+ and I_{C+}** (refer to figure4-18).

When connecting, make sure that the connected cables **I_{C-} and M_-** are connected directly to the resistance thermometer.

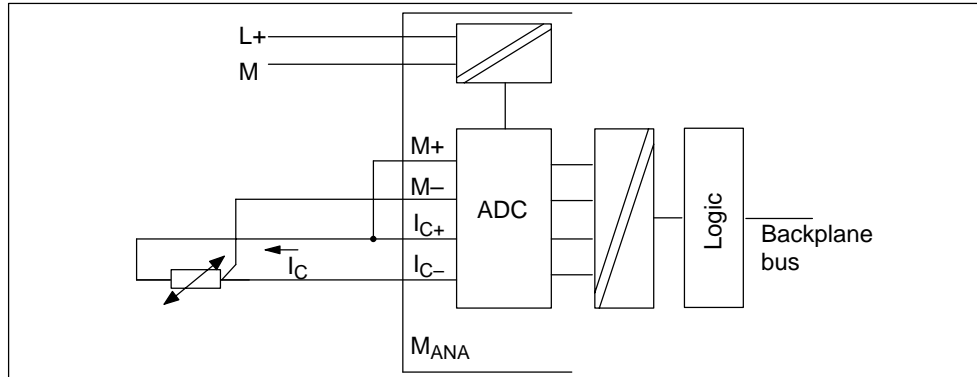

Figure 4-18 Three-Conductor Connection of Resistance Thermometers to the SM 331; AI 8 × RTD



Caution

Due to incorrect wiring of the three-conductor connection, unforeseen operation of the module and dangerous conditions can result in the system.

4.11.1 Connecting Resistance Thermometers to the SM 331; AI 8 × 13 bits

Two-conductor connection

With a two-conductor connection, you must insert jumpers on the module between M– and S–.

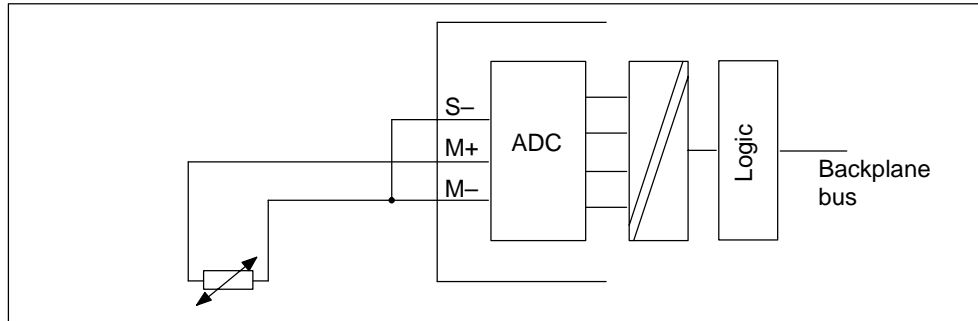

Figure 4-19 Two-Conductor Connection of Resistance Thermometers to the SM 331;
AI 8 × 13 bits

Three-conductor connection

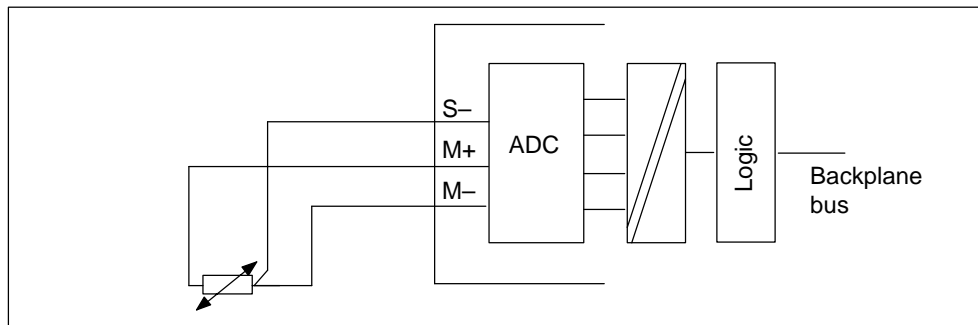

Figure 4-20 Three-Conductor Connection of Resistance Thermometers to the SM 331;
AI 8 × 13 bits

Four-conductor connection

With a four-conductor connection, you must not connect the fourth conductor (the conductor is not used at all, see Figure 4-21).

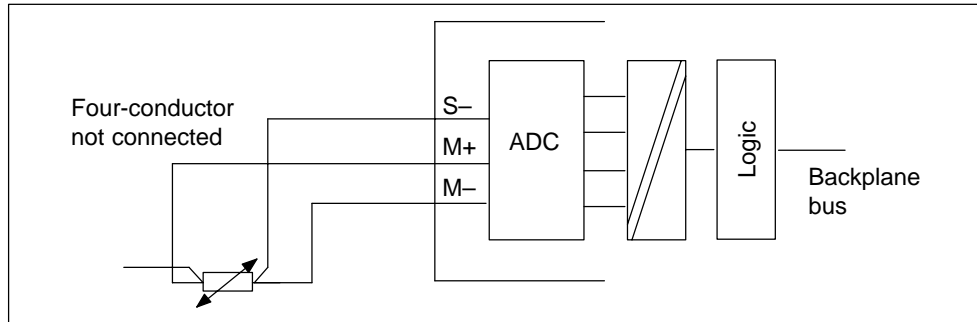

Figure 4-21 Four-Conductor Connection of Resistance Thermometers to the SM 331;
AI 8 × 13 bits

4.12 Connecting Thermocouples

Design of thermocouples

A thermocouple consists of a pair of sensors and the necessary installation and connecting parts. The thermocouple consists of two wires of dissimilar metals or metal alloys soldered or welded together at the ends.

There are different types of thermocouple, depending on the composition of the material used – for example, K, J, N thermocouples. The measuring principle of all thermocouples is the same, irrespective of their type.

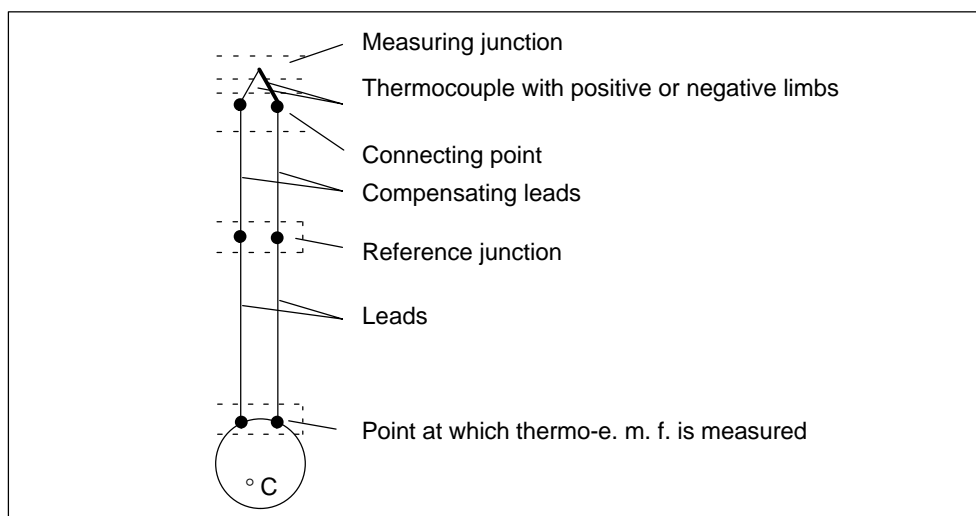

Figure 4-22 Design of Thermocouples

Principle of operation of thermocouples

If the measuring point is subjected to a temperature different from that of the free ends of the thermocouple (point of connection), a voltage, the thermo emf, occurs at the free ends. The magnitude of the thermo-e.m.f. generated depends on the difference between the temperature at the measuring junction and the temperature at the free ends, as well as on the material combination used for the thermocouple.

Since a thermocouple always measures a temperature difference, the free ends must be kept at a known temperature at a reference junction in order to determine the temperature of the measuring junction.

The thermocouples can be extended from their point of connection to the reference junction by means of compensating wires. These compensating wires consist of the same material as the thermocouple wires. The supply leads are copper wire.

Note: Make sure these wires are connected with the correct polarity, otherwise there will be considerable measuring errors.

Compensation of the reference junction temperature

You can compensate for the effects of temperature fluctuations at the reference junction by means of compensating leads.

There are several options for you to choose from for acquiring the reference junction temperature in order to obtain an absolute temperature value from the difference in temperature between the reference junction and measuring point.

You can use internal or external compensation, depending on where you want the reference junction to be.

Table 4-44 Options for Compensation of the Reference Junction Temperature

Option	Explanation
No compensation	If you want to acquire only the difference in temperature between the measuring point and the reference junction.
Internal compensation (refer to Figure 4-23 for connection)	If you employ internal compensation, the internal temperature (thermocouple internal comparison) of the module is used for comparison purposes.
External compensation with compensating box in the leads of an individual thermocouple (refer to Figures 4-24 and 4-25 for its connection)	You have already acquired and compensated the reference junction temperature (thermocouple external comparison) using a compensating box, which you have looped into an individual thermocouple. No further processing is necessary owing to the module.
Only for SM 331; AI 8 × TC: External compensation with resistance thermometer for acquisition of the reference junction temperature (refer to Figure 4-26 and 4-27 for connection)	You can acquire the reference temperature by means of a resistance thermometer (platinum or nickel) and have it calculated by the module for any thermocouple.

Theory of operation of internal compensation

With internal compensation, you can establish the reference point across the terminals of the analog input modules. In this case, you must run the compensating lines right up to the analog module. The internal temperature sensor acquires the temperature of the module and supplies a compensation voltage.

Note that internal compensation is not as accurate as external compensation.

Theory of operation of external compensation with compensating box

If you employ external compensation, the temperature of the reference junction of the thermocouples is taken into account via a compensating box, for example.

The compensating box contains a bridge circuit calibrated for a definite reference junction temperature. The reference junction is formed by the connections for the ends of the thermocouple's compensating leads.

If the actual temperature deviates from the compensating temperature, the temperature-sensitive bridge resistance changes. This results in a positive or negative compensating voltage, which is added to the thermo-e.m.f.

Abbreviations and mnemonics used in the figures below

The abbreviations and mnemonics used in the figures below have the following meanings:

M +:	Measuring lead (positive)
M-:	Measuring lead (negative)
I _C +:	Positive connection of constant current output
I _C -:	Negative connection of constant current output
COMP ₊ :	Compensating terminal (positive)
COMP ₋ :	Compensating terminal (negative)
M _{ANA} :	Reference potential of the analog measuring circuit
M :	Ground terminal
L +:	Terminal for 24 VDC supply voltage
P5V:	Module logic power supply

Note

The necessary connecting cables, which result from the potential connection of the analog input module and the sensors, are not drawn in the figures shown below.

In other words, you must continue to take note of and implement Section 4.8 with its generally valid information for connecting sensors.

Connection of thermocouples with internal compensation

Connect the thermocouples to the inputs of the module, either directly or by means of compensating lines. Each channel group can use a thermocouple type supported by the analog module independently of the other channel groups.

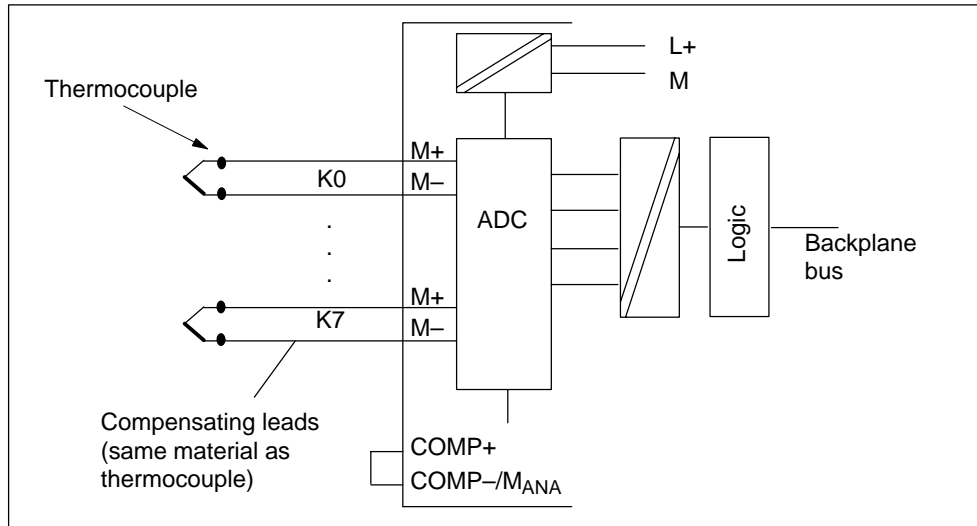

Figure 4-23 Connection of Thermocouples with Internal Compensation to an Isolated AI

Connecting the compensating box

Connect the compensating box to the COMP terminals of the module, locating the compensating box at the reference junction of the thermocouples. The compensating box must have an isolated supply. The power supply must have adequate filtering, for example by means of a grounded shielding winding.

The terminals for connecting the thermocouple to the compensating box are not required and must therefore be shorted (refer to Figure 4-25 for an example).

The following constraints apply:

- The parameters of a channel group are general valid for all channels of that group (for example, input voltage, integrating time etc.)
- External compensation with connection of the compensating box to the COMP terminals of the module can be performed only for one thermocouple type. In other words, all channels operating with external compensation must use the same type.

Connecting thermocouples with compensating box

If all thermocouples connected to the inputs of the module have the same comparison point, you compensate as follows:

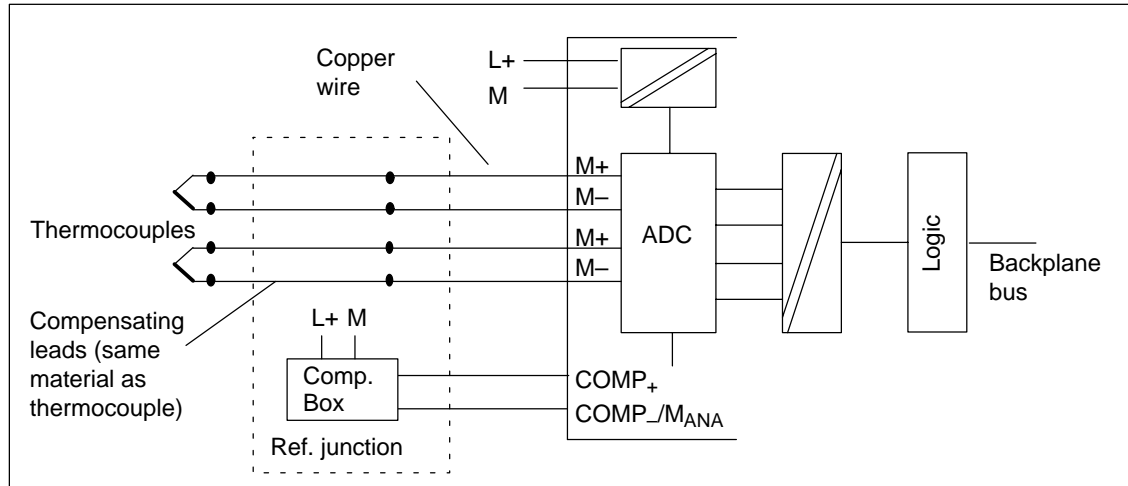

Figure 4-24 Connection of Thermocouples with Compensation Box to an Isolated AI

Note

Use compensating boxes with a **reference junction temperature of 0°C** for analog input modules.

Recommended compensating box

We recommend you to use a comparison point (with integrated power supply unit) from Siemens as a compensating box. You will find the necessary ordering data in the table below.

Table 4-45 Ordering Data of the Comparison Point

Recommended Compensating Box		Order number
Reference junction with integrated power supply unit, for rail mounting		M72166-□□□□
Auxiliary power		↑ ↑ ↑ ↑
	220 VAC	B
	110 VAC	1
	24 VAC	B
	24 VDC	2
Connection to thermocouple		B
	Fe-CuNi Type L	3
	Fe/Cu Ni Type J	B 1
	Ni Cr/Ni Type K	4 2
	Pt 10% Rh/Pt Type S	3
	Pt 13% Rh/Pt Type R	4
	Cu/Cu Ni Type U	5
	Cu/Cu Ni Type T	6
Reference temperature		7
		0
		0

Connecting to the comparison point (Order No. M72166-xxx00)

If all thermocouples connected to the inputs of the module have the same comparison point, you compensate as follows:

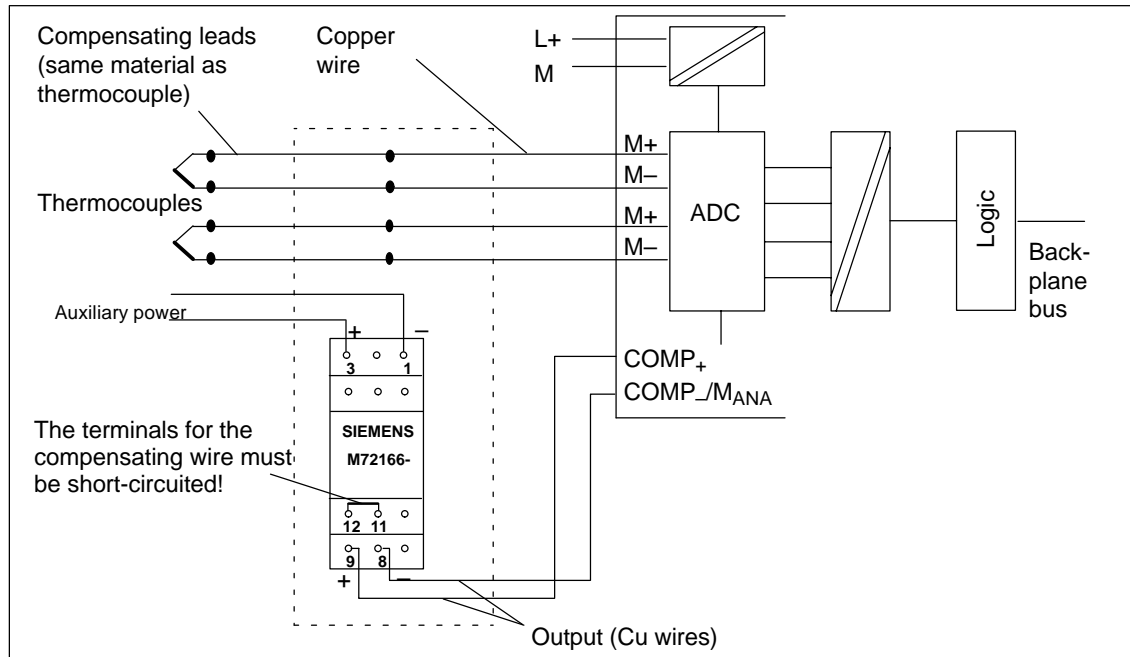

Figure 4-25 Connection of Thermocouples with Comparison Point (Order No. M72166-xxx00) to an Isolated AI

Connecting thermocouples with temperature compensation to the SM 331; AI 8 × TC

All 8 inputs are available as measurement channels when the thermocouples are connected via reference junctions that are controlled at 0 °C or 50 °C.

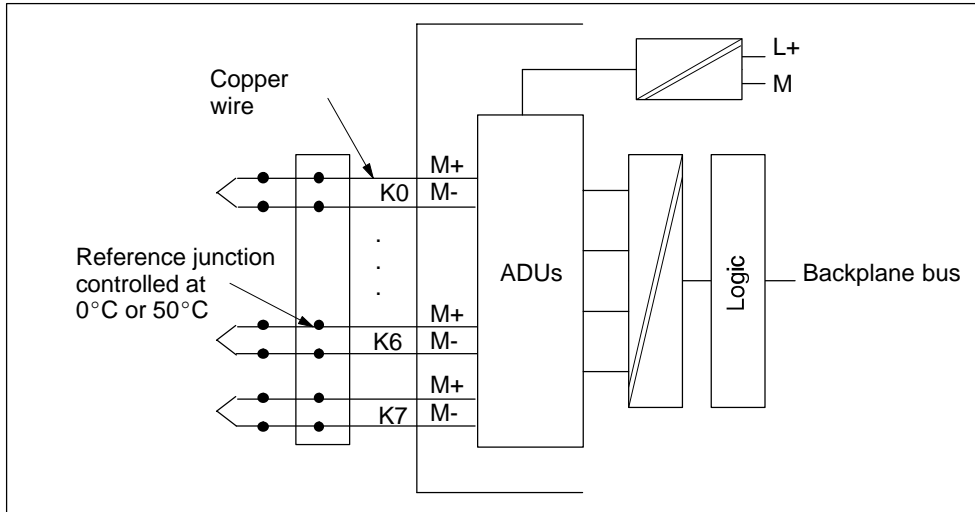

Figure 4-26 Connecting Thermocouples via a Reference Junction to the SM 331; AI 8 × TC

Connecting thermocouples with resistance thermometer to the SM 331; AI 8 × TC

With this type of compensation, the reference junction terminal temperature is determined by a bulb resistor sensor with a temperature range of $-25\text{ }^{\circ}\text{C}$ to $85\text{ }^{\circ}\text{C}$.

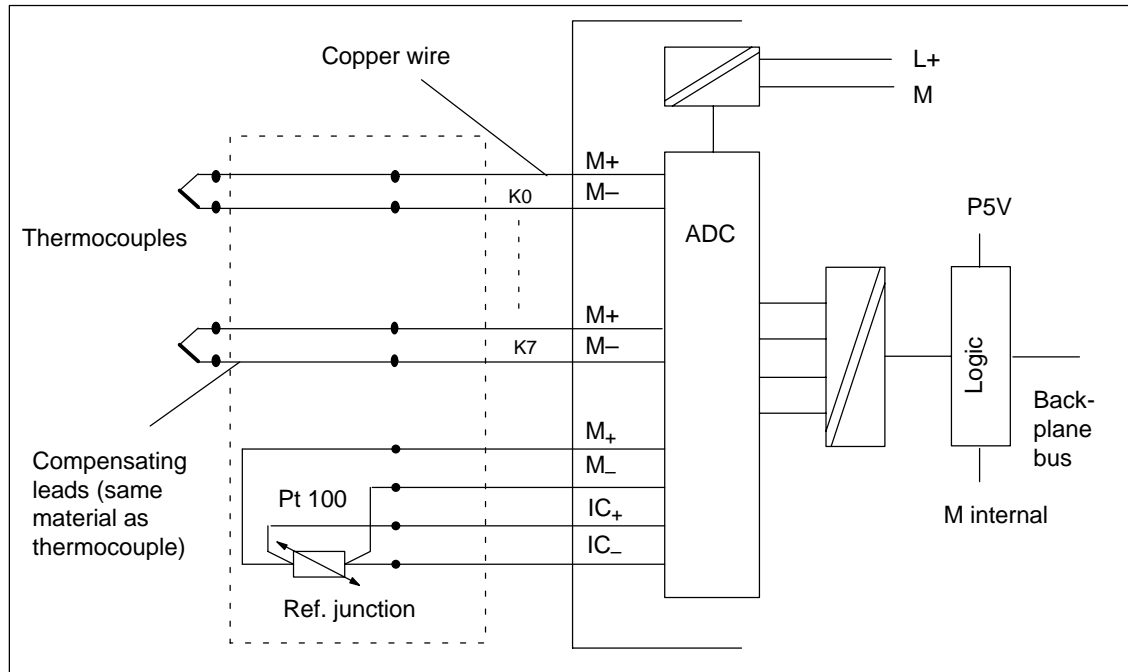

Figure 4-27 Connecting Thermocouples with External Compensation via Resistance Thermometers to the SM 331; AI 8 × TC

4.13 Connecting Loads/Actuators to Analog Output

Introduction

You can use the analog output modules to supply loads and actuators with current and voltage.

This section contains general information that is generally applicable to all the connection options for loads and actuators described in the sections that follow.

Cables for analog signals

For the analog signals, you should use shielded and twisted pair cables. The cables Q_V and $S+$ and M and $S-$, respectively, are to be twisted together. This reduces the interference. Ground the screen of the analog cables at both ends of the cables.

If there are potential differences between the cable ends, an equipotential bonding current, which can flow over the shield, can cause interference of the analog signals. In such a case, you should ground the shield at one end of the cable only.

Isolated analog output modules

With the isolated analog output modules there is no electrical connection between the reference point of the measuring circuit M_{ANA} and the M terminal of the CPU.

You must use isolated analog output modules if a potential difference U_{ISO} can occur between the reference point of the measuring circuit M_{ANA} and the M terminal of the CPU. By means of a equipotential bonding conductor between the M_{ANA} terminal and the M terminal of the CPU, make sure that U_{ISO} does not exceed the permitted value.

Non-isolated analog output modules

With the non-isolated analog output modules, you must establish a connection between the reference point of the measuring circuit M_{ANA} and the M terminal of the CPU. Therefore, connect the M_{ANA} terminal with the M terminal of the CPU. A potential difference between M_{ANA} and the M terminal of the CPU can lead to a corruption of the analog signal.

4.14 Connecting Loads and Actuators to Voltage Outputs

Connecting loads to a voltage output

Connecting loads to a voltage output is possible both in a four-conductor and a two-conductor connection. However, not all analog output modules allow both types of connection.

Note

The necessary connecting cables, which result from the potential connection of the analog output module, are not drawn in the figures shown below.

In other words, you must continue to take note of and implement Section 4.13 with its generally valid information for connecting loads and actuators.

Abbreviations and mnemonics used in the figures below

The abbreviations and mnemonics used in the figures below have the following meanings:

Q _V :	Analog output voltage
S +:	Detector lead (positive)
S-:	Detector lead (negative)
M _{ANA} :	Reference potential of analog circuit
R _L :	Load impedance
L +:	Terminal for 24 VDC supply voltage
M :	Ground terminal
U _{ISO} :	Potential difference between M _{ANA} and M terminal of CPU.

Connecting loads to a voltage output of an isolated module over a four-conductor connection

A high accuracy at the load can be achieved through the four-conductor connection. You must therefore connect the sensor leads (S– and S+) directly to the load. The voltage is thus measured and corrected directly at the load.

Interferences or a voltage drop can result in a potential difference between the sensor lead S– and the reference circuit of the analog circuit M_{ANA} . This potential difference must not exceed the permissible value. If the permissible potential difference is exceeded, the accuracy of the analog signal is impaired.

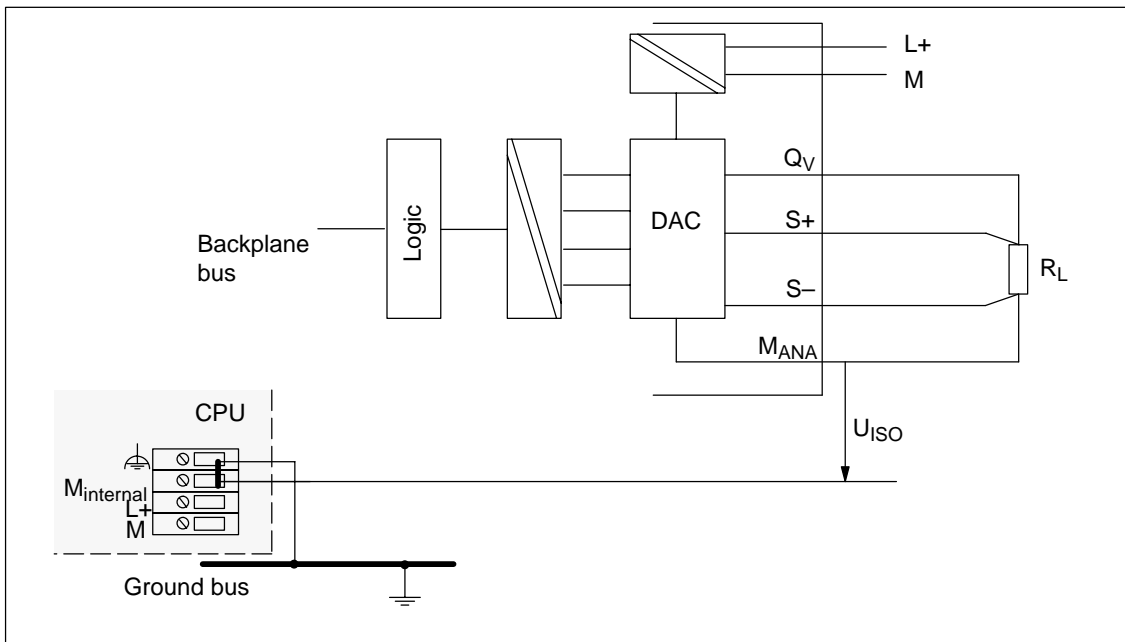

Figure 4-28 Connecting Loads to a Voltage Output of an Isolated AO over a Four-Conductor Connection

Connecting loads to a voltage output of a non-isolated module over a two-conductor connection

With a two-conductor connection, the S+ and S– terminals can be left open. However, you will not achieve the accuracy of a four-conductor connection.

Connect the load to terminals Q_V and the reference point of the measuring circuit, M_{ANA}.

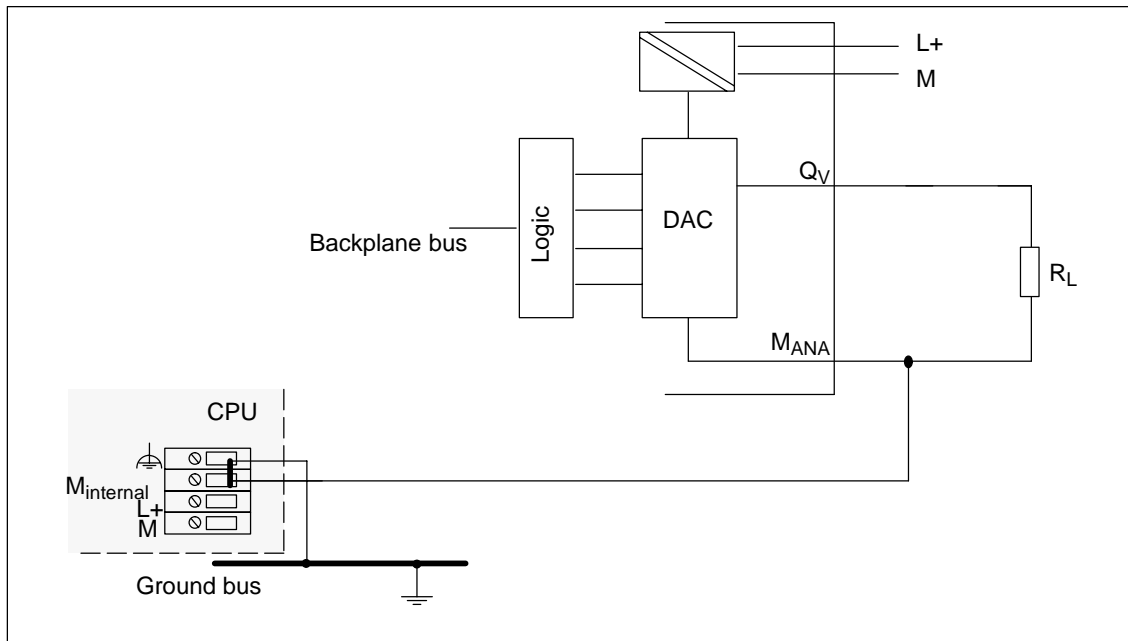

Figure 4-29 Connecting Loads to a Voltage Output of a Non-Isolated AO over a Two-Conductor Connection

4.15 Connecting Loads and Actuators to Current Outputs

Note

The necessary connecting cables, which result from the potential connection of the analog output module, are not drawn in the figures shown below.

In other words, you must continue to take note of and implement Section 4.13 with its generally valid information for connecting loads and actuators.

Abbreviations and mnemonics used in the figures below

The abbreviations and mnemonics used in the figures below have the following meanings:

- Q_i: Analog output current
- M_{ANA}: Reference potential of analog circuit
- R_L: Load impedance
- L +: Terminal for 24 VDC supply voltage
- M : Ground terminal
- U_{ISO}: Potential difference between M_{ANA} and M terminal of CPU.

Connecting loads to a current output

You must connect loads to Q_i and the reference point of the analog circuit M_{ANA} of a current output.

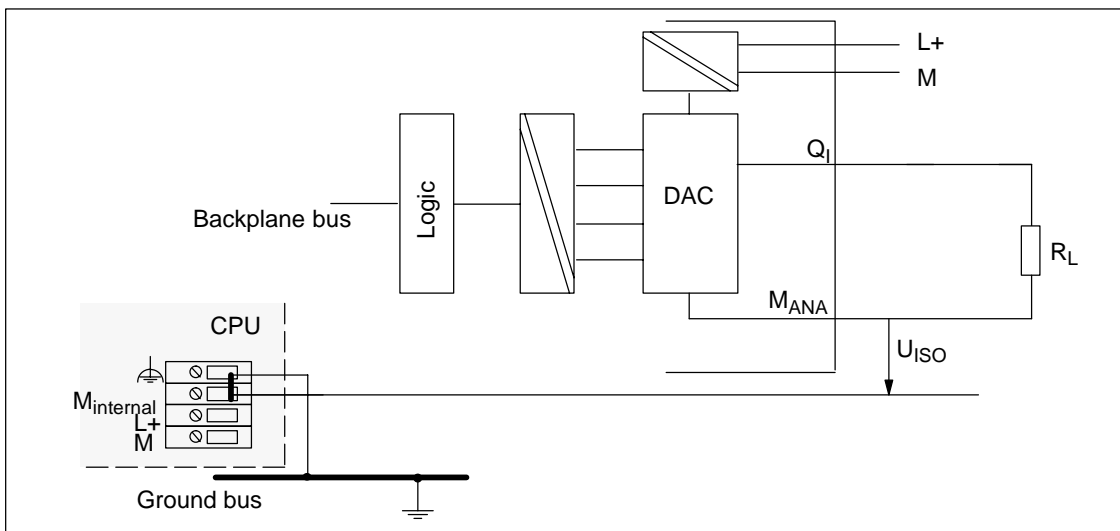

Figure 4-30 Connecting Loads to a Current Output of an Isolated AO

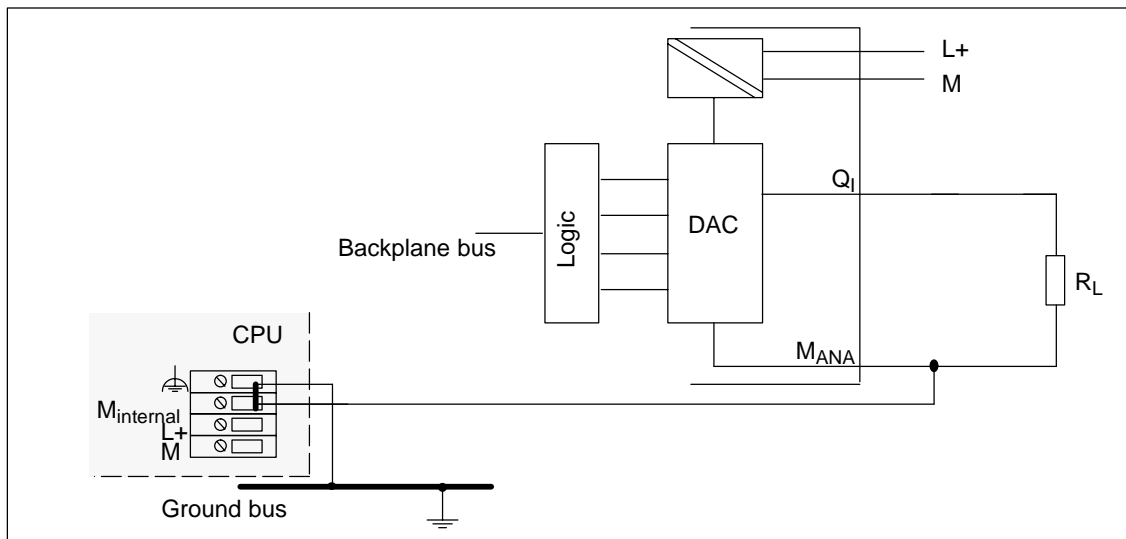

Figure 4-31 Connecting Loads to a Current Output of a Non-Isolated AO

4.16 Diagnostics of the Analog Modules

Programmable and non-programmable diagnostic messages

In diagnostics, we make a distinction between programmable and non-programmable diagnostic messages.

You obtain programmable diagnostic messages only if you have enabled diagnostics by parameter assignment. You perform parameter assignment in the "Diagnostics" parameter field in *STEP 7* (refer to Section 4.7).

Non-programmable diagnostic messages are always made available by the analog module irrespective of diagnostics being enabled.

Actions following diagnostic message in *STEP 7*

Each diagnostic message leads to the following actions:

- The diagnostic message is entered in the diagnosis of the analog module and forwarded to the CPU.
- The error LED on the analog module lights.
- If you have programmed "Enable Diagnostic Interrupt" with *STEP 7*, a diagnostic interrupt is triggered and OB 82 is called (refer to Section 4.17).

Reading out diagnostic messages

You can read out detailed diagnostic messages by means of SFCs in the user program (refer to the Appendix "Diagnostic Data of Signal Modules").

You can view the cause of the error in *STEP 7*, in the module diagnosis (refer to online Help for *STEP 7*).

Diagnostic message in the measured value of analog input modules

Every analog input module supplies the measured value 7FFF_H irrespective of the parameter assignment when an error is detected. This measured value means either Overflow, Malfunction or a channel is disabled.

Diagnostic message by means of SF LED

Every analog module indicates errors for you by means of your SF LED (group error LED). The SF LED lights as soon as a diagnostic message is triggered by the analog module. It goes out when all errors have been rectified.

Diagnostic messages of the analog input modules

The table below gives an overview of the diagnostic messages for the analog input modules.

Table 4-46 Diagnostic Messages of the Analog Input Modules

Diagnosics Message	LED	Diagnosics Effective for	Parameters can be Assigned
External auxiliary supply missing	SF	Module	No
Configuring/parameter assignment error	SF	Channel	Yes
Common-mode error	SF	Channel	Yes
Wire-break	SF	Channel	Yes
Underflow	SF	Channel	Yes
Overflow	SF	Channel	Yes

Diagnostic messages of the analog output modules

The table below gives an overview of the diagnostic messages for the analog output modules.

Table 4-47 Diagnostics Messages of the Analog Output Modules

Diagnostics Message	LED	Diagnostics Effective for	Parameters can be Assigned
External auxiliary supply missing	SF	Module	No
Configuring/parameter assignment error	SF	Channel	Yes
Short-circuit to M	SF	Channel	Yes
Wire-break	SF	Channel	Yes

Note

A prerequisite for detecting the errors indicated by programmable diagnostic messages is that you have assigned parameters to the analog module accordingly in *STEP 7*.

Causes of errors and remedial measures for analog input modules

Table 4-48 Diagnostics Messages of the Analog Input Modules, Causes of Errors and Remedial Measures

Diagnostics Message	Possible Error Cause	Remedy
External load voltage missing	Load voltage L+ of module missing	Feed supply L+
Configuring/parameter assignment error	Illegal parameters transferred to module	Check measuring range module
		Reassign module parameter
Common-mode error	Potential difference U_{CM} between the inputs (M-) and reference potential of measuring circuit (M_{ANA}) too high	Connect M- with M_{ANA}
Wire-break	Resistance too high in the sensor connection	Use different type of sensor or connection, e.g. use conductors with a larger cross-sectional core area
	Open circuit between module and sensor	Close circuit
	Channel not connected (open)	Disable channel group ("measuring procedure" parameter)
Connect channel		

Table 4-48 Diagnostics Messages of the Analog Input Modules, Causes of Errors and Remedial Measures

Diagnostics Message	Possible Error Cause	Remedy
Underflow	Input value underflows underrange, error may be caused: Wrong measuring range selected	Configure other measuring range
	With the measuring ranges 4 to 20 mA and 1 to 5 V, if necessary by polarity reversal of sensor connection	Check terminals
Overflow	Input value overflows overrange	Configure other measuring range

Causes of errors and remedial measures for analog output modules

Table 4-49 Diagnostics Messages of the Analog Output Modules, Causes of Errors and Remedial Measures

Diagnostics Message	Possible Error Cause	Remedy
External load voltage missing	Load voltage L+ of module missing	Feed supply L+
Configuring/parameter assignment error	Illegal parameters transferred to module	Reassign module parameter
Short-circuit after M	Overload of output	Eliminate overload
	Short-circuit of output Q_V after M_{ANA}	Eliminate short circuit
Wire-break	Actuator resistance too high	Use different type of actuator or connection, e.g. use conductors with a larger cross-sectional core area
	Open circuit between module and actuator	Close circuit
	Channel not used (open)	Disable channel group ("output type" parameter)

4.17 Interrupts of the Analog Modules

Introduction

In this Section, the interrupt behavior of the analog modules is described. The following interrupts exist:

- Diagnostic interrupt
- Hardware interrupt

Note that not all analog modules have interrupt capability or they are only capable of a subset of the interrupts described here. Refer to the technical specifications of the modules, starting at Section 4.21, to determine which analog modules have interrupt capability.

The OBs and SFCs mentioned below can be found in the online Help for *STEP 7*, where they are described in greater detail.

Enabling interrupts

The interrupts are not preset – in other words, they are inhibited without appropriate parameter assignment. Assign parameters to the Interrupt Enable in *STEP 7* (refer to Section 4.7).

Diagnostic interrupt

If you have enabled diagnostic interrupts, then active error events (initial occurrence of the error) and departing error events (message after troubleshooting) are reported by means of an interrupt.

The CPU interrupts the execution of the user program and processes the diagnostic interrupt block (OB 82).

In the user program, you can call SFC 51 or SFC 59 in OB 82 to obtain more detailed diagnostic information from the module.

The diagnostic information is consistent until such time as OB 82 is exited. When OB 82 is exited, the diagnostic interrupt is acknowledged on the module.

Hardware interrupt with trigger "Upper or lower limit exceeded"

Define a working range by setting parameters for an upper and lower limit value. If the process signal (for example, the temperature) leaves this working range, the module triggers a hardware interrupt, provided the interrupt is enabled.

The CPU interrupts execution of the user program and processes the hardware interrupt block (OB 40).

In the user program of OB 40, you can set how the programmable logic controller is required to react to a limit value being surpassed or not being reached.

When OB 40 is exited, the hardware interrupt is acknowledged on the module.

Note

Note that a hardware interrupt is not triggered if you have set the upper limit above the overrange or the lower limit below the underrange.

Structure of the start information tag OB40_POINT_ADDR of OB 40

The limit values exceeded by the different channels are entered in the start information of OB 40 in the tag OB40_POINT_ADDR. The following figure shows the assignment to the bits of local data double word 8.

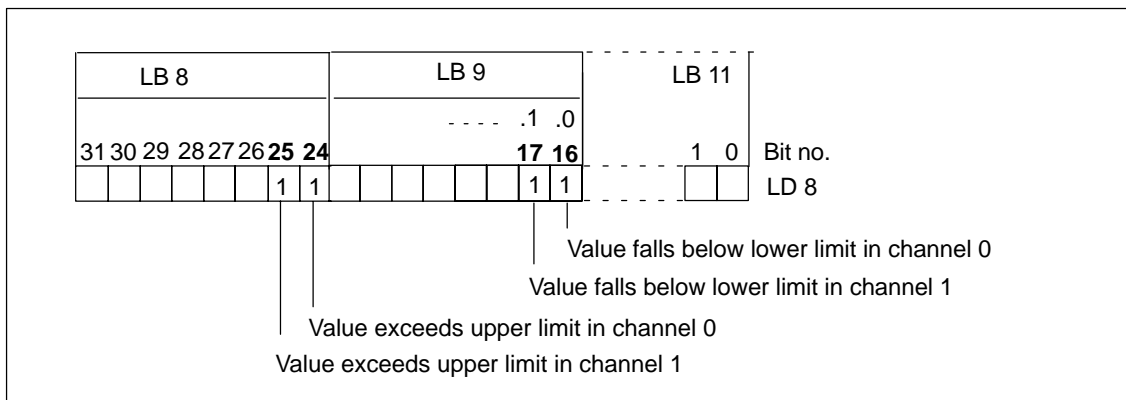

Figure 4-32 Start Information of OB 40: Which Event Has Triggered the Hardware Interrupt at the Limit Value

Hardware interrupt upon trigger "Reached end of scan cycle"

By parameterizing the hardware interrupt at the end of the scan cycle, you have the option of synchronizing a process with the scan cycle of the analog input module.

A scan cycle includes the conversion of the measured values of all enabled channels of the analog input module. The module processes the channels one after the other. After all the measured values have been converted, the module of the CPU reports by means of an interrupt that there are new measured values on all channels.

You can use the interrupt to load the currently converted analog values.

**4.18 Analog Input Module SM 331; AI 8 × 16 bits;
(6ES7 331-7NF00-0AB0)****Order number**

6ES7 331-7NF00-0AB0

Characteristics

The analog input module SM 331; AI 8 × 16 bits has the following characteristic features:

- 8 inputs in 4 channel groups
- Measured-value resolution 15 bits + sign (independent of integration time)
- Measurement mode selectable per channel group:
 - Voltage
 - Current
- Arbitrary measuring range and filter/update rate selection per channel group
- Programmable diagnostics
- Programmable diagnostic interrupt
- Two channels with limit monitoring
- Programmable hardware interrupt when limit has been exceeded
- Isolated against the backplane bus interface
- Permissible common mode voltage between channels of 50 VDC maximum

Terminal connection diagram and block diagram of the SM 331; AI 8 × 16 bits

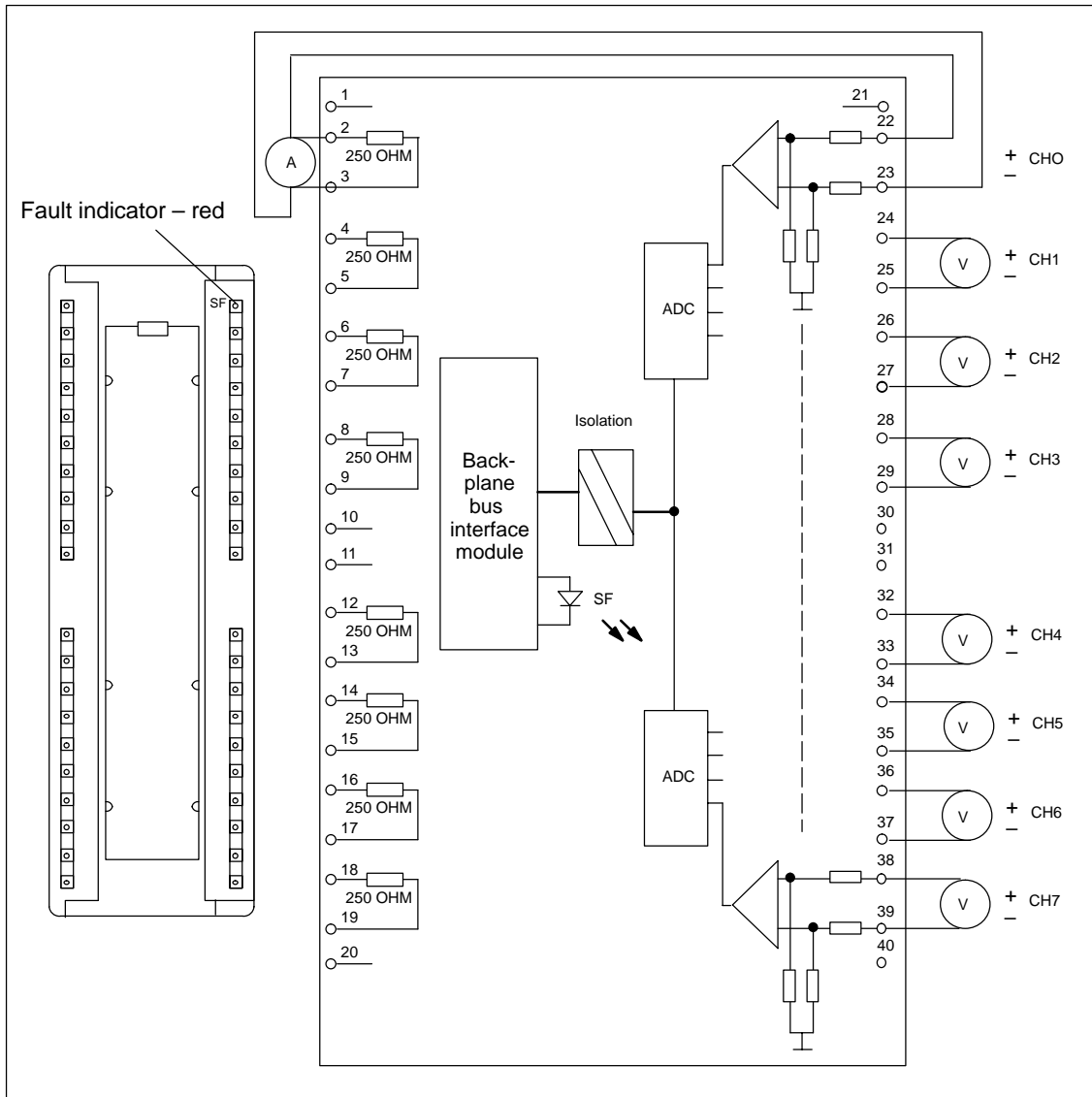

Figure 4-33 Module View and Block Diagram of the Analog Input Module SM 331; AI 8 × 16 bits

Please note that in Figure 4-33, channel 0 is configured for current measurement and channel 7 for voltage measurement.

Wiring of the module for measuring current

Current measurements are made by paralleling a channel's voltage input terminals with its respective current sense resistor. This is accomplished by jumpering the channels input terminals to the adjacent terminals on the field connector.

Example: To configure channel 0 for current mode, you must jumper terminal 22 to 2 and terminal 23 to 3.

The channel being configured for current measurements must be paired with the sense resistor connected to the channel's adjacent terminals in order to achieve the specified accuracy.

Technical specifications of the SM 331; AI 8 × 16 bits

Dimensions and Weight		Analog Value Generation				
Dimensions W × H × D (in millimeters)	40 × 125 × 117	Measuring principle	Integrating			
Weight	Approx. 272 g	Integration time/conversion time/ resolution (per channel)				
Data for Specific Module		<ul style="list-style-type: none"> Parameters can be assigned 	Yes			
Supports clocked operation	No	<ul style="list-style-type: none"> Integration time in milliseconds 	10	16.7	20	100
Number of inputs	8	<ul style="list-style-type: none"> Basic conversion time per channel group when more than one channel group is active 	35	55	65	305
Length of cable		<ul style="list-style-type: none"> Channel conversion time per channel group if only channel group 0 or 1 is enabled 	10	16.7	20	100
<ul style="list-style-type: none"> Shielded 	max. 200 m	Channel integration time (1/f1) in ms	10	16.7	20	100
Voltages, Currents, Potentials		<ul style="list-style-type: none"> Resolution including sign 	15 bits + sign			
Isolation		<ul style="list-style-type: none"> Suppression of interference voltage for interference frequency f1 in Hertz 	100	60	50	10
<ul style="list-style-type: none"> Between channels and backplane bus 	Yes	Basic execution time of the module, in ms (all channels enabled)	140	220	260	1220
Permitted potential difference						
<ul style="list-style-type: none"> Between the inputs (ECM) 	50 VDC, 35 VAC					
<ul style="list-style-type: none"> Between M_{ANA} and M_{internal} (U_{ISO}) 	75 VDC / 60 VAC					
Insulation tested with	500 VDC					
Current consumption						
<ul style="list-style-type: none"> From the backplane bus 	max. 130 mA					
Power dissipation of the module	typically 0.6 W					

Suppression of Interference, Limits of Error	Status, Interrupts, Diagnostics
<p>Noise suppression for $f = n \times (f_1 \pm 1\%)$, ($f_1$ = interference frequency); $n= 1, 2, \dots$</p> <ul style="list-style-type: none"> • Common-mode noise > 100 dB ($U_{cm} < 50$ V) • Series-mode interference > 90 dB (peak value of interference $<$ rated value of input range) <p>Crosstalk between the inputs > 100 dB</p> <p>Operational limit (over entire temperature range, referred to input range) $U_{CM} = 0 / U_{CM} = \pm 50$ V</p> <ul style="list-style-type: none"> • Voltage input $\pm 0.1\% / \pm 0.7\%$ • Current input $\pm 0.3\% / \pm 0.9\%$ <p>Basic error (operational limit at 25° C referred to input range)</p> <ul style="list-style-type: none"> • Voltage input $\pm 0.05\%$ • Current input $\pm 0.05\%$ <p>Temperature error (with reference to the input range) $\pm 0.005\%/K$</p> <p>Linearity error (with reference to the input range) $\pm 0.03\%$</p> <p>Repeat accuracy (in the steady state at 25° C, referred to the input range) $\pm 0.025\%$</p>	<p>Interrupts</p> <ul style="list-style-type: none"> • Hardware interrupt when limit has been exceeded Programmable channels 0 and 2 • Diagnostic Interrupt Programmable <p>Diagnostic functions Programmable</p> <ul style="list-style-type: none"> • Group error display Red LED (SF) • Diagnostics information read-out Possible <p>Data for Selecting a Sensor</p> <p>Input range (rated values)/Input resistance</p> <ul style="list-style-type: none"> • Voltage ± 5 V / $2M\Omega$ 1 to 5 V / $2M\Omega$ ± 10 V / $2M\Omega$ • Current 0 to 20 mA; / 250Ω ± 20 mA / 250Ω 4 to 20 mA: / 250Ω <p>Maximum input voltage for voltage input (destruction limit) max. 50 V continuous</p> <p>Maximum input current for current input (destruction limit) max. 32 mA</p> <p>Connection of the sensor</p> <ul style="list-style-type: none"> • For measuring voltage Possible • For measuring current <ul style="list-style-type: none"> As two-wire transmitter Possible As four-wire transmitter Possible • Load of the two-wire transmitter max. 820Ω

4.18.1 Commissioning the SM 331; AI 8 × 16 bits

You set the mode of operation of the SM 331; AI 8 × 16 bits *STEP 7*.

Parameter

You will find a description of the general procedure for assigning parameters to analog modules in Section 4.7.

An overview of the parameters that you can set and their default settings are shown in the table below.

Table 4-50 Parameters of the SM 331; AI 8 × 16 bits

Parameter	Value Range	Default Settings	Parameter Type	Scope
Enable <ul style="list-style-type: none"> Diagnostic interrupt Hardware interrupt upon limit violation 	Yes/no Yes/no	No No	Dynamic	Module
Trigger for hardware interrupt <ul style="list-style-type: none"> Upper limit value Lower limit value 	Constraint possible due to measuring range. 32511 to -32512 -<32512 to 32511	–	Dynamic	Channel
Diagnostics <ul style="list-style-type: none"> Group diagnostics With wire-break check 	Yes/no Yes/no	No No	Static	Channel group
Measurement <ul style="list-style-type: none"> Measuring method Measuring range Interference suppression 	Deactivated U Voltage 4DMU Current (4-wire transmitter) Refer to Section 4.18.2 for the measuring ranges of the input channels that you can set. 400 Hz; 60 Hz; 50 Hz; 10 Hz	U ± 10 V 50 Hz	Dynamic	Channel group

Channel groups

The channels of the SM 331; AI 8×16 bits are arranged in four groups of two. You can only ever assign parameters to one channel group.

The table below shows which channels are parameterized as a channel group in each case. You will need the channel group number to set the parameters in the user program with an SFC.

Table 4-51 Assignment of Channels of the SM 331; AI 8×16 bits to Channel Groups

Channels form one Channel Group each
Channel 0	Channel group 0
Channel 1	
Channel 2	Channel group 1
Channel 3	
Channel 4	Channel group 2
Channel 5	
Channel 6	Channel group 3
Channel 7	

High speed update mode

In the high speed update mode, updates for the two channels in the group occur three times faster than with multiple channel groups enabled.

Example: If channels 0 and 1 are enabled with 2.5 ms filtering, data updates for both channels will be available to the PLC every 10 msec. (For other filter settings, the filter setting equals the update rate.)

The high speed update mode is only available when both channels are enabled on channel group 0 or 1, in other words, the "measuring method" parameter is set. However, only channel group 0 or only channel 1 (in other words, not both together) must be enabled.

Special characteristic of channel groups for hardware interrupts

You can set hardware interrupts in *STEP 7* for the channel groups 0 and 1. Note, however, that a hardware interrupt is set only for the first channel in the channel group in each case – in other words, for channel 0 or channel 2

Diagnostics

You will find the diagnostic messages that are grouped under the "group diagnosis" parameter in Table 4-46, on page 4-78.

4.18.2 Measuring Methods and Measuring Ranges of the SM 331; AI 8 × 16 bits

Measuring methods

You can set the following measuring methods for the input channels:

- Voltage measurement
- Current measurement

You perform the setting with the "measuring method" parameter in *STEP 7*.

Unused channels

Set the "measuring method" parameter for unused channels to "disabled". In this way you shorten the scan time of the module.

Since configured inputs can remain unused because of the channel group generation, you must take note of the following special characteristics of these inputs to enable the diagnostic functions on the used channels.

- **Measuring range 1 to 5 V:** Connect the unused input in parallel with a used input of the same channel group.
- **Current measurement 4 to 20 mA:** Connect the unused input in series with an input of the same channel group. Ensure that a current sense resistor is connected for each active and unused channel.
- **Other ranges:** Short the positive to the negative input of the channel.

Measuring ranges

You perform setting of the measuring ranges with the "measuring range" parameter in *STEP 7*.

Table 4-52 Measuring Ranges of the SM 331; AI 8 x 16 bits

Method Selected	Measuring Range	Description
U: Voltage	±5 V 1 to 5 V ±10 V	You will find the digitized analog values in Section 4.3.1 in the voltage measuring range
4DMU: Current (4-wire transmitter)	from 0 to 20 mA ±20 mA from 4 to 20 mA	You will find the digitized analog values in Section 4.3.1 in the current measuring range

Default settings

The default settings of the module are "voltage" for the measuring method "± 10 V" for the measuring range. You can use this combination of measuring method and measuring range without parameterizing the SM 331; AI 8 × 16 bits in *STEP 7*.

Measuring errors with common-mode voltages

The SM 331; AI 8 x 16 bits can make measurements in the presence of AC or DC common mode voltage.

For **AC common mode voltages** at multiples of the filter frequency setting, the rejection is accomplished by the integration period of the A/D converter and by the common mode rejection of the input amplifiers. For AC common mode voltages < 35 V_{RMS}, the rejection ratio of > 100 dB results in negligible measurement error.

For **DC common mode voltages**, only the rejection of the input amplifier stage is available to minimize the effect of the common mode voltage. Therefore, some accuracy degradation occurs in proportion to the common mode voltage. The worst case error occurs with 50 VDC between one channel and the other seven channels. The calculated worst case error is 0.7 % at 0 to 60 °C, and measured error is typically ≤ 0.1% at 25 °C.

Special characteristic of parameter assignment to upper and lower limit values

The parameterizable limit values (triggers for hardware interrupt) differ for the SM 331; AI 8 x 16 bits from the range of values contained in Table 4-50.

The reason for this is that numerical methods in the module software for evaluating the process variables prevent values up to 32511 from being reported in some cases. The process input value at which a hardware interrupt for an underflow or overflow occurs depends on the calibration factors for an individual channel and can vary between the lower limits shown in the Table below and 32511 (7EFF_H).

Limit values should not be set at values higher than the minimum potential limit values shown in the table below.

Table 4-53 Minimum Possible Upper and Lower Limit Values of SM 331; AI 8 x 16 bits

Measuring Range	Minimum Possible Upper Limit Value	Minimum Possible Lower Limit Value
±10 V	11.368 V 31430 7AC6 _H	-11.369 V -31433 8537 _H
±5 V	5.684 V 31430 7AC6 _H	-5.684 V -31430 853A _H
1 to 5 V	5.684 V 32376 7E78 _H	0.296 V -4864 ED00 _H
0 to 20 mA	22.737 mA 31432 7AC8 _H	-3.519 mA -4864 ED00 _H
4 to 20 mA	22.737 mA 32378 7E7A _H	1.185 mA -4864 ED00 _H
±20 mA	22.737 mA 31432 7AC8 _H	-22.737 mA -31432 8538 _H

Wire-break check

The wire-break check is available for the 1 to 5 V voltage range and the 4 to 20 mA current range.

The following applies to both measuring ranges:

Enabled wire-break check, the analog input module enters a wire-break in the diagnosis if a current falls below 3.6 mA (0.9 V).

If you have enabled diagnostics interrupt during configuration, the module additionally triggers a diagnostic interrupt.

If no diagnostic interrupt has been enabled, the illuminated SF LED is the only indication of the wire-break and you must evaluate the diagnostic bytes in the user program.

With a **disabled** wire-break check and enabled diagnostic interrupt, the module triggers a diagnostic interrupt when the underflow is reached.

4.19 Analog Input Module SM 331; AI 8 × 16 bits (6ES7 331-7NF10-0AB0)

Order number

6ES7 331-7NF10-0AB0

Characteristics

The isolated analog input module SM 331; AI 8 × 16 bits has the following characteristic features:

- 8 isolated inputs in 4 channel groups
- Measured-value resolution 15 bits + sign
- Rapid measured value updating for up to 4 channels
- Measuring method selectable per channel group
- Programmable diagnostics
- Programmable diagnostic interrupt
- 8 channels with limit monitoring
- Programmable hardware interrupt when limit has been exceeded
- Programmable end-of-scan-cycle interrupt
- Electrical isolation to the backplane bus interface

Special feature

When you use the SM 331; AI 8 × 16 bits in the distributed peripheral ET 200M, you must have one of the following IM153-x:

- IM 153-1 6ES7 153-1AA03-0XB0, E 01
- IM 153-2 6ES7 153-2AA02-0XB0, E 05
- IM 153-2 6ES7 153-2AB01-0XB0, E 04

Terminal connection diagram and block diagram of the SM 331; AI 8 × 16 bits

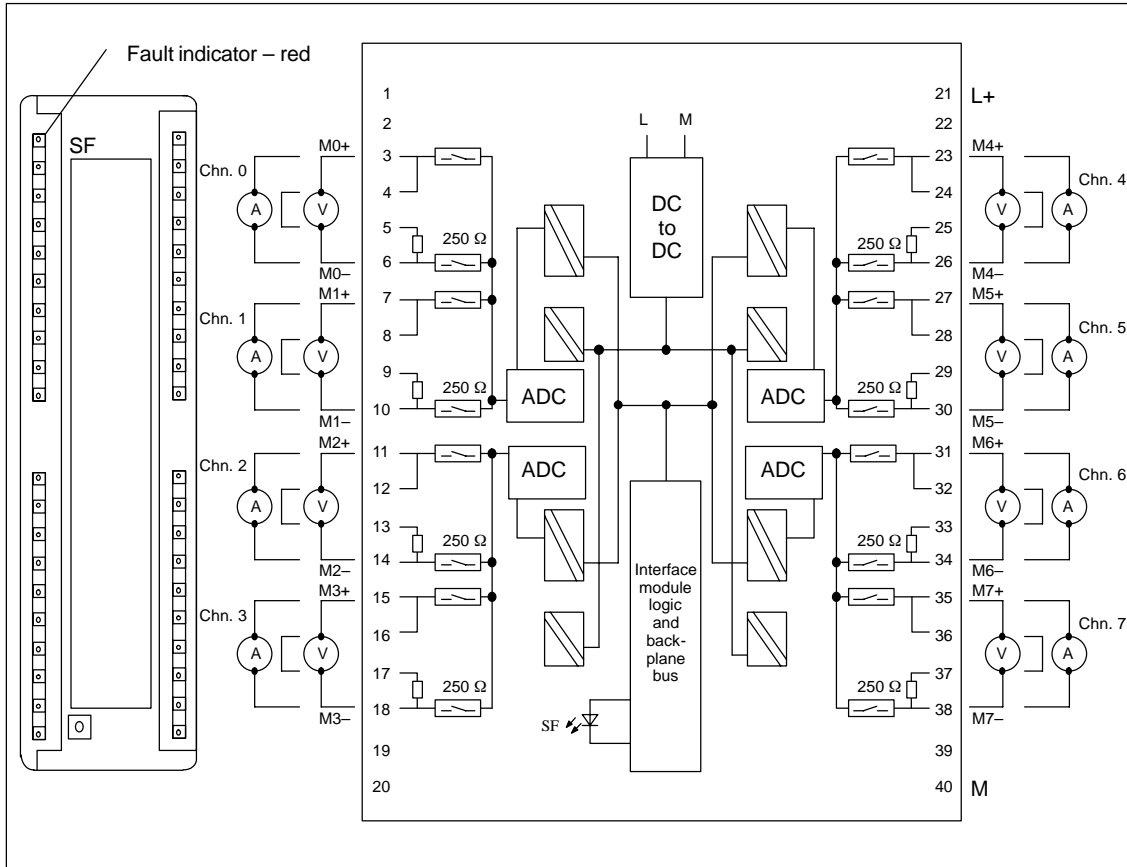

Figure 4-34 Module View and Block Diagram of the SM 331; AI 8 x 16 bits

Technical specifications of the SM 331; AI 8 × 16 bits

Dimensions and Weight		Analog Value Generation	
Dimensions W × H × D (in millimeters)	40 × 125 × 117	Measuring principle	Integrating
Weight	Approx. 272 g	Integration time/conversion time/ resolution (per channel)	
Data for Specific Module		<ul style="list-style-type: none"> Parameters can be assigned 	Yes
Supports clocked operation	No	<ul style="list-style-type: none"> Basic conversion time in ms (8-channel mode) 	95/83/72/23
Number of inputs	8	<ul style="list-style-type: none"> Basic conversion time in ms (4-channel mode) 	10 ¹⁾
Length of cable		<ul style="list-style-type: none"> Resolution including sign 	16 bits
<ul style="list-style-type: none"> Shielded 	max. 200 m	<ul style="list-style-type: none"> Noise suppression for frequency f1 in Hz 	All ²⁾ /50/60/400
Voltages, Currents, Potentials		Smoothing of the measured values	None / low/ average/ high
Power rated voltage of the electronics L+	24 VDC	Basic execution time of the module, in ms (8-channel-mode)	190/166/144//46
<ul style="list-style-type: none"> Reverse polarity protection 	Yes	Basic execution time of the module, in ms (4-channel-mode)	10 ¹⁾
Isolation		Suppression of Interference, Limits of Error	
<ul style="list-style-type: none"> Between channels and backplane bus 	Yes	Interference suppression for F = n × (f1 ± 1%) (f1 = interference frequency, n = 1, 2, ...)	
<ul style="list-style-type: none"> Between channels and power supply of the electronics 	Yes	<ul style="list-style-type: none"> Common-mode interference (U_{cm} < AC 60 V) 	> 100 dB
<ul style="list-style-type: none"> Between the channels in groups of 	Yes 2	<ul style="list-style-type: none"> Series-mode interference (peak value of interference < rated value of input range) 	>90 dB ³⁾
Permitted potential difference		Crosstalk between the inputs	> 100 dB
<ul style="list-style-type: none"> Between the inputs (ECM) 	75 VDC / 60 VAC	Operational limit (in the entire temperature range, with reference to the input range)	
<ul style="list-style-type: none"> Between M_{ANA} and M_{internal} (U_{ISO}) 	75 VDC / 60 VAC	<ul style="list-style-type: none"> Input voltage 	± 0.1%
Insulation tested with	500 VAC	<ul style="list-style-type: none"> Input current 	± 0.1%
Current consumption		Basic error (operational limit at 25 °C, referred to input range)	
<ul style="list-style-type: none"> From the backplane bus 	max. 100 mA	<ul style="list-style-type: none"> Voltage input 	± 0.05%
<ul style="list-style-type: none"> From the power supply L+ 	max. 200 mA	<ul style="list-style-type: none"> Current input 	± 0.05%
Power dissipation of the module	typ. 3.0 W	Temperature error (with reference to the input range)	± 0.005%/K

Linearity error (with reference to the input range)	$\pm 0.01\%$
Repeat accuracy (in the steady state at 25 °C, referred to the input range)	$\pm 0.01\%$

Status, Interrupts, Diagnostics	
Interrupts	
• Hardware interrupt if the limit value is exceeded	Programmable channels 0 – 7
• Hardware interrupt at end of cycle	Parameters can be assigned
• Diagnostic interrupt	Parameters can be assigned
Diagnostic functions	
Parameters can be assigned	
• Group error display	Red LED (SF)
• Diagnostics information read-out	Possible
Data for Selecting a Sensor	
Input range (rated values) / input resistance	
• Voltage	$\pm 5\text{ V} / 2\text{ M}\Omega$ 1 to 5 V / 2 M Ω $\pm 10\text{ V} / 2\text{ M}\Omega$
• Current	0 to 20 mA / 250 Ω 4 to 20 mA / 250 Ω $\pm 20\text{ mA} / 250\ \Omega$
Maximum input voltage for voltage input (destruction limit)	35 VDC continuous; 75 VDC for max. 1 s (duty factor 1:20)
Maximum input current for current input (destruction limit)	40 mA
Connection of the sensor	
• For measuring voltage	Possible
• For measuring current	
As two-wire transmitter	Possible with separate supply for the transmitter
As four-wire transmitter	Possible

- 1) Interference frequency for 4-channel mode is "All"
- 2) Interference frequencies 50/60/400 Hz are designated as "All"
- 3) Series-mode rejection for 8-channel mode is reduced as follows:

50 Hz	> 70 db
60 Hz	> 70 db
400 Hz	> 80 dB
50/60/400 Hz	> 90 dB

4.19.1 Commissioning the SM 331; AI 8 × 16 bits

You set the mode of operation of the SM 331; AI 8 × 16 bits in *STEP 7*.

Parameter

You will find a description of the general procedure for parameterizing the SM 331; AI 8 × 16 bits, in section 4.7.

Parameterization restrictions when using the analog input module SM 331; AI 8 x 16 bits with PROFIBUS masters that only support DPV0.

When you use the isolated analog input module SM 331; AI 8 × 16 bits in an ET200M PROFIBUS slave system with a PROFIBUS master which is not an S7 master, certain parameters are not permitted. Masters that are not S7 masters do not support hardware interrupts. So all the parameters associated with these functions are deactivated. The deactivated parameters are hardware interrupt enable, hardware restrictions and end-of-scan-cycle interrupt enable. All the other parameters are permitted.

An overview of the parameters that you can set and their default settings are shown in the table below.

Table 4-54 Parameters of the SM 331; AI 8 x 16 bits

Parameter	Value Range	Default settings	Parameter Type	Scope
Enable				
• Hardware interrupt if the limit value is exceeded	Yes/no	No	Dynamic	Module
• Hardware interrupt at end of cycle	Yes/no	No	Dynamic	
• Diagnostic Interrupt	Yes/no	No	Dynamic	
Hardware interrupt trigger				
• Upper limit	32511 to -32512	-	Dynamic	Channel
• Lower limit	-32512 to 32511	-	Dynamic	Channel
Diagnostics				
• Group diagnostics	Yes/no	No	Static	Channel
• Wire-break check	Yes/no	No		Channel
Measurement				
• Module mode	<ul style="list-style-type: none"> • 8 channels • 4 channels 	Yes No	Dynamic	Module
• Interference suppression	50 Hz 60 Hz 400 Hz 50/60/400 Hz	50/60/400 Hz		Channel group
• Smoothing	<ul style="list-style-type: none"> • None • Low • Average • High 	None	Dynamic	Channel group
• Measuring method	• Measuring Range:		Dynamic	Channel group
Deactivated				
Voltage	<ul style="list-style-type: none"> • ± 5 V • 1 to 5 V • ± 10 V 	± 10 V		
Current (4-wire transmitter)	<ul style="list-style-type: none"> • 0 to 20 mA • 4 to 20 mA • ± 20 mA 	4 to 20 mA		

Channel groups

The channels of the SM 331; AI 8×16 bits are arranged in groups of two inputs each. You must assign the same parameters to both the inputs in a group. The interrupt limits are the exception here.

Table 4-55 shows which channels of the isolated analog input module SM 331; AI 8×16 bits are configured as a channel group. To set the parameters by means of SFC in the user program, you need the numbers of the channel groups. Detailed information on this can be found in Appendix A.

Table 4-55 Assignment of the Channels of the Isolated Analog Input Module SM 331; AI 8×16 bits to Channel Groups

Channels form one channel group each
Channel 0	Channel group 0
Channel 1	
Channel 2	Channel group 1
Channel 3	
Channel 4	Channel group 2
Channel 5	
Channel 6	Channel group 3
Channel 7	

Operating states

The following modes are available for the isolated analog input module SM 331; AI 8×16 bits:

- 8 channels
- 4 channels

4.19.2 8-Channel Mode

Description of the module cycle

In 8-channel mode, the isolated analog input module SM 331; AI 8×16 bits switches between the two channels in each group. As the module contains four analog/digital converters (ADC), all four of the ADCs convert simultaneously for channels 0, 2, 4 and 6. Once the even-numbered channels have been converted all the ADCs simultaneously convert for the odd-numbered channels 1, 3, 5 and 7 (see Figure 4-35).

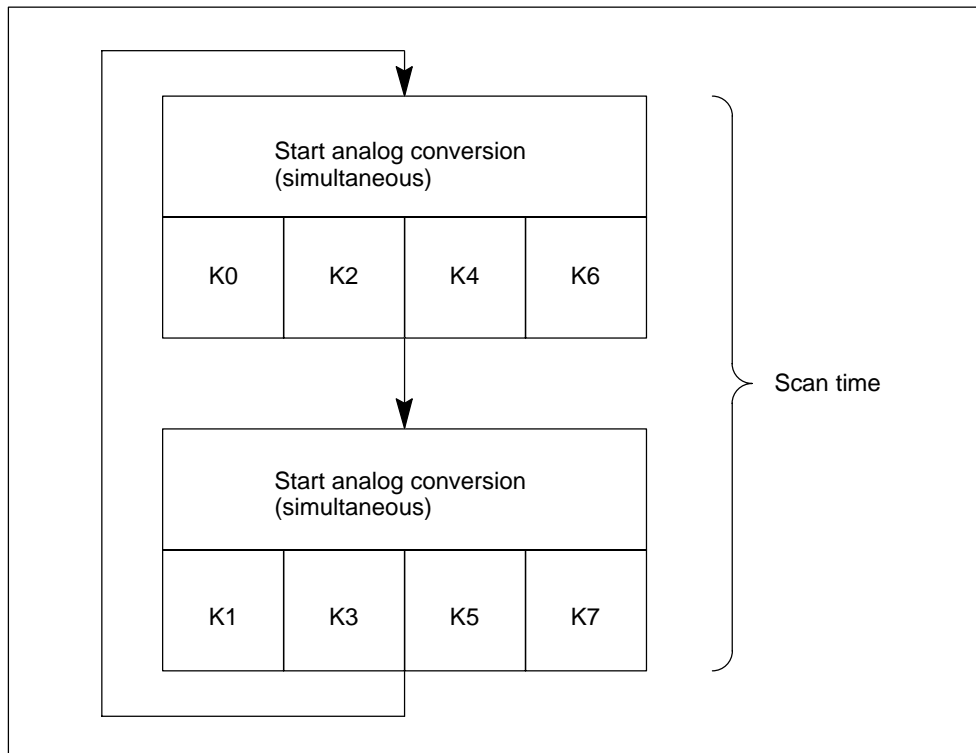

Figure 4-35 8-Channel Mode Cycle

Scan time of the module

In the 8-channel mode of the SM 331; AI 8×16 bits, the channel conversion time is guided by the interference frequency set. When you set an interference frequency of 50 Hz, the channel conversion time including communication time is 76 ms. When you set an interference frequency of 60 Hz, the channel conversion time is 65 ms. When you set an interference frequency of 400 Hz, the channel conversion time is reduced to 16 ms. When you set an interference frequency of 50, 60 and 400 Hz, the channel conversion time is 88 ms. The module must then be switched over to the other channel of the group by means of opto-MOS relays. Opto-MOS relays need 7 ms to switch and settle. Table 4-56 shows the scan times of the module at certain interference frequencies.

Table 4-56 Scan Times in 8-Channel Mode

Interference frequency (Hz)	Channel scan time (ms)	Module scan time (All channels)
50	83	166
60	72	144
400	23	46
400/60/50	95	190

4.19.3 4 Channel-Mode

Description of the module cycle

In 4-channel mode, the SM 331; AI 8×16 bits does not switch over between the channels of the individual groups. As the module contains four analog/digital converters (ADC), all four of the ADCs convert simultaneously for channels 0, 2, 4 and 6.

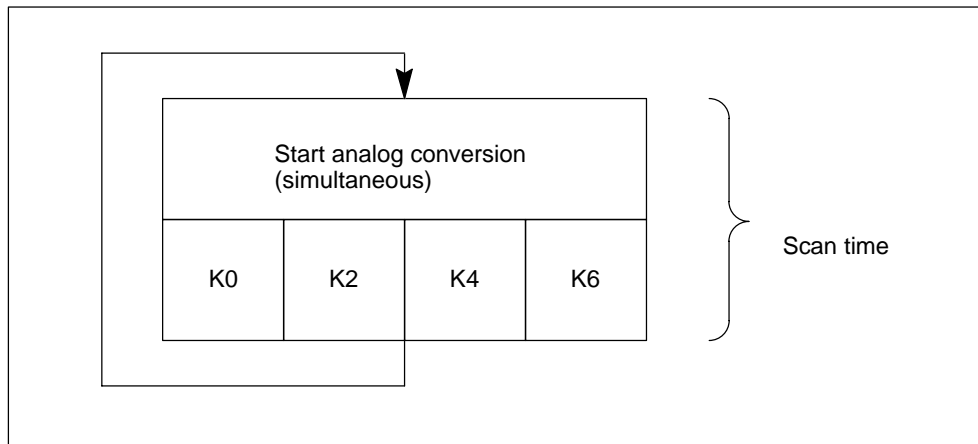

Figure 4-36 4-Channel Mode Cycle

Scan time of the module

In 4-channel mode, the channel conversion time including communication time of the SM 331; AI 8×16 bits is 10 ms. As the module does not switch over between the channels in a group, the channel scan time and the module scan time are the same: 10 ms.

4.19.4 Measuring Methods and Measuring Ranges of the SM 331; AI 8 × 16 bits

Measuring methods

You can set the following measuring methods for the input channels:

- Voltage measurement
- Current measurement (4-wire transmitter)

You perform the setting with the "measuring method" parameter in *STEP 7*.

Unused channels

Set the "measuring method" parameter for unused channels to "disabled". In this way you shorten the scan time of the module.

Since configured inputs can remain unused because of the channel group generation, you must take note of the following special characteristics of these inputs to enable the diagnostic functions on the used channels.

- **Measuring range 1 to 5 V:** Connect the unused input in parallel with a used input of the same channel group.
- **Current measurement 4 to 20 mA:** Connect the unused input in series with an input of the same channel group. Ensure that a current sense resistor is connected for each active and unused channel.
- **Other ranges:** Short the positive to the negative input of the channel.

Wire-break check

The wire-break check is a module software function that is available for all the voltage ranges and the current range of 4 to 20 mA.

- With the ± 5 V, 1 to 5 V or ± 10 V measuring ranges and an **enabled** wire-break check, the isolated analog input module enters a wire-break in the diagnosis when the process value achieves a positive full-scale deflection (32768). If you enabled the diagnostic interrupt during configuration, the analog input module also triggers a diagnostic interrupt.

If the diagnostic interrupt has not been enabled, the illuminated SF display is the only indication that there is a wire-break. You must then assess the diagnosis bytes in the user program.

- With a measuring range of 4 to 20 mA and an **enabled** wire-break check, the isolated analog input module enters wire-break in the diagnosis when the process value falls below 3.6 mA. If you enabled the diagnostic interrupt during configuration, the analog input module also triggers a diagnostic interrupt.

If the diagnostic interrupt has not been enabled, the illuminated SF display is the only indication that there is a wire-break. You must then assess the diagnosis bytes in the user program.

- If the wire-break check is not enabled, the isolated analog input module triggers a diagnostic interrupt if the limit value for underflow is not reached.

Measuring ranges

You perform setting of the measuring ranges with the "measuring range" parameter in *STEP 7*.

Table 4-57 Measuring Ranges of the SM 331; AI 8 × 16 bits

Method Selected	Output Range	Description
Voltage	± 5 V From 1 to 5 V ± 10 V	You will find the digital analog values in Section 4.3.1 in the voltage and current output ranges
Current (4-wire transmitter)	From 0 to 20 mA From 4 to 20 mA ± 20 mA	

Short circuit to M or L

If you short an input channel to M or L, the module does not suffer any damage. The channel continues to issue valid data; neither is a diagnosis reported.

Overflow, underflow and hardware interrupt limits

The diagnosis operating limits for overflow and underflow for some of the measuring ranges differ from those given in section 4.3.1 of the manual. In some cases, numerical methods in the module software to assess the process variables prevent values up to 32511 being signaled.

Hardware interrupt limits must not be set to values greater than the smallest possible limit value of the overflow or underflow operating limits for the end-of-scan-cycle interrupt in section 4.3.1.

End-of-scan-cycle interrupt

By enabling the end-of-scan-cycle interrupt, you can synchronize a process with the conversion cycle of the module. The interrupt occurs when the conversion of all the enabled channels is complete.

Table 4-58 Content of the 4 Bytes with Additional Information from OB40 during a Hardware Interrupt or an End-of-Scan-Cycle Interrupt

Content of the 4 bytes with additional information		2 ⁷	2 ⁶	2 ⁵	2 ⁴	2 ³	2 ²	2 ¹	2 ⁰	Byte
Analog special markers	2 bits per channel to identify the range									
	Upper limit exceeded in channel	7	6	5	4	3	2	1	0	0
	Lower limit exceeded in channel	7	6	5	4	3	2	1	0	1
	End-of-scan-cycle event						X			2
	Unassigned bit									3

4.20 Analog Input Module SM 331; AI 8 × 13 bits; (6ES7 331-1KF00-0AB0)

Order number

6ES7 331-1KF00-0AB0

Characteristics

The analog input module SM 331; AI 8 × 13 bits has the following characteristic features:

- 8 inputs
- Measured-value resolution 12 bits + sign
- Measuring method selectable
 - Voltage
 - Current
 - Resistors
 - Bulb resistor
- Isolated against the backplane bus interface

Terminal connection diagram and block diagram of the SM 331; AI 8 × 13 bits

The following diagram uses channels 4 to 7 to show some connection examples for the various measuring methods. These connection examples apply to all channels accordingly (channels 0 to 7).

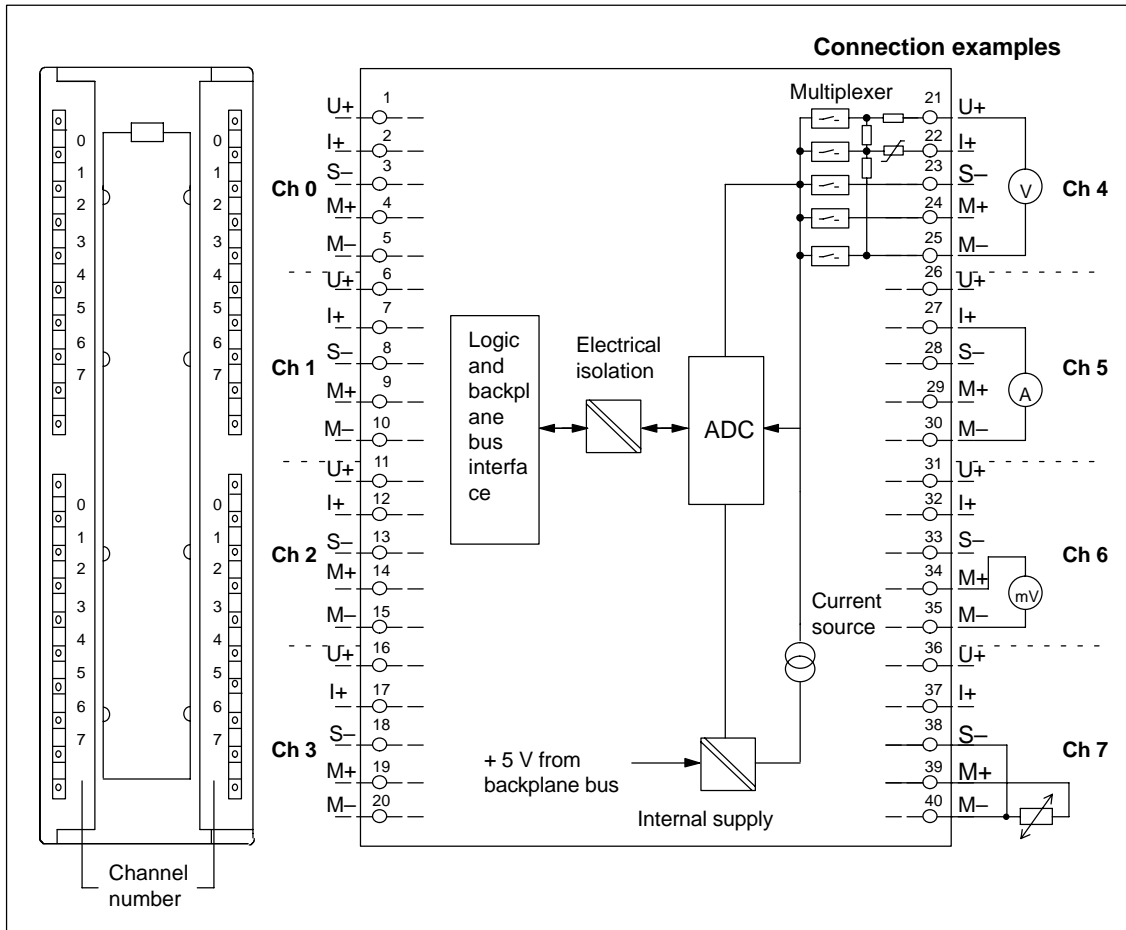

Figure 4-37 Module View and Block Diagram of the Analog Input Module SM 331; AI 8 × 13 bits

Note

When connecting the voltage and current sensors, make sure that you do not exceed the maximum permitted common-mode voltage U_{CM} of 2 V between the inputs. So to prevent measuring errors, interconnect the individual M- terminals.

It is not necessary to interconnect the M- terminals when measuring resistors and resistance temperature detectors.

Technical specifications of the SM 331; AI 8 × 13 bits

Dimensions and Weight		Analog Value Generation		
Dimensions W × H × D (in millimeters)	40 × 125 × 117	Measuring principle	Integrating	
Weight	Approx. 250 g	Integration time/conversion time/ resolution (per channel)		
Data for Specific Module		<ul style="list-style-type: none"> Parameters can be assigned 	Yes	
Supports clocked operation	No	<ul style="list-style-type: none"> Noise suppression for frequency f1 in Hz 	50	60
Number of inputs	8	<ul style="list-style-type: none"> Integration time in milliseconds 	20	16 ² / ₃
<ul style="list-style-type: none"> For resistance-type sensor 	8	<ul style="list-style-type: none"> Basic conversion time including Integration time in milliseconds 	66	55
Length of cable	max. 200 m	Additional conversion time for measuring resistance, in ms	66	55
<ul style="list-style-type: none"> Shielded 	max. 50 m at 50 mV	<ul style="list-style-type: none"> Resolution in bits (incl. overrange) 	13 bits	13 bits
Voltages, Currents, Potentials		Suppression of Interference, Limits of Error		
Power rated voltage of the electronics	from bus -5 V	Noise suppression for $f = n \times (f1 \pm 1 \%)$, (f1 = interference frequency) n = 1.2		
Constant current for resistance-type sensor		<ul style="list-style-type: none"> Common-mode interference ($U_{CM} < 2 V$) 	> 86 dB	
<ul style="list-style-type: none"> Resistance temperature detectors and resistance measurement 0 to 600 Ω 	0.83 mA	<ul style="list-style-type: none"> Series-mode noise (peak value of noise < nominal value of input range) 	> 40 dB	
<ul style="list-style-type: none"> Resistance measurement 0 to 6 kΩ 	0.25 mA	Crosstalk between the inputs	> 50 dB	
Isolation		Operational limit (in the entire temperature range, with reference to the input range)		
<ul style="list-style-type: none"> Between channels and backplane bus 	Yes	<ul style="list-style-type: none"> Voltage input 	± 5 V ± 10 V	± 0.6 %
<ul style="list-style-type: none"> Between the channels 	No		1 to 5 V	
Permitted potential difference			0 to 10 V	
<ul style="list-style-type: none"> Between the inputs (ECM) 	2.0 VDC		± 50 mV	± 0.5 %
<ul style="list-style-type: none"> Between M_{ANA} and M_{internal} (U_{ISO}) 	75 VDC / 60 VAC		± 500 mV	
Insulation tested with	500 VDC		± 1 V	
Current consumption		<ul style="list-style-type: none"> Current input 	± 20 mA	± 0.5 %
<ul style="list-style-type: none"> From the backplane bus 	max. 90 mA		0 to 20 mA	
Power dissipation of the module	typ. 0.4 W		4 to 20 mA	
		<ul style="list-style-type: none"> Resistors 	0 to 6 kΩ	± 0.5 %
			0 to 600 Ω	± 0.5 %
		<ul style="list-style-type: none"> Resistance thermometer 	Pt 100 standard	± 1.2 K
			Pt 100 climate	± 1 K

Basic error (operational limit at 25 °C referred to input range)		
• Voltage input	± 5 V × ± 10 V 1 to 5 V 0 to 10 V	± 0.4 %
	± 50 mV ± 500 mV ± 1 V	± 0.3 %
• Current input	± 20 mA 0 to 20 mA 4 to 20 mA	± 0.3 %
• Resistors	0 to 6 kΩ 0 to 600 Ω	± 0.3 % × ± 0.3 %
• Resistance thermometer	Pt 100 standard Pt 100 climate	± 1 K ± 0.8 K
Temperature error (with reference to the input range)	± 0.06 %/K / 0.06 K/K	
Linearity error (with reference to the input range)	± 0.1 % / 0.1 K	
Repeatability (in steady state at 25 °C referred to input range)	± 0.1 % / ± 0.1 K	
Status, Interrupts, Diagnostics		
Interrupts	None	
Diagnostic functions	None	

Data for Selecting a Sensor		
Input range (rated values)/Input resistance		
• Voltage	± 50 mV ± 500 mV ± 1 V ± 5 V ± 10 V 1 to 5 V; 0 to 10 V	100 kΩ
• Current	± 20 mA 0 to 20 mA; 4 to 20 mA:	50 Ω
• Resistors	0 to 6 kΩ 0 to 600 Ω	100 MΩ
• Resistance thermometer	Pt 100 standard / climate	100 MΩ
Maximum input voltage for voltage input U+ (destruction limit)	max. 30 V continuous	
Maximum input voltage for voltage input M+, M-, S- (destruction limit)	max. 12 V continuous; 30 V for max. 1 s	
Maximum input current for current input I+ (destruction limit)	40 mA	
Connection of the sensor		
• For measuring voltage	Possible	
• For measuring current		
As two-wire transmitter	Possible, with external supply	
As four-wire transmitter	Possible	
• For measuring resistance		
With two-conductor connection	Possible	
With three-conductor connection	Possible	
With four-conductor connection	Possible	
Characteristic linearization	Parameters can be assigned	
• For RTD	Pt 100 standard / climate	
• Technical unit for temperature measurement	Degrees Celsius, degrees Fahrenheit, Kelvin	

4.20.1 Parameters of the SM 331; AI 8 × 13 bits

Parameter

You will find a description of the general procedure for assigning parameters to the analog modules in Section 4.7.

An overview of the parameters that you can set and their default settings are shown in the table below.

Table 4-59 Parameters of the SM 331; AI 8 × 13 bits

Parameter	Value Range	Default Settings	Parameter Type	Scope
Measurement <ul style="list-style-type: none"> Measuring Method 	Deactivated U Voltage I Current R Resistors RTD Bulb resistor	U	Dynamic	Channel
<ul style="list-style-type: none"> Measuring Range 	Voltage ± 50 mV; ± 500 mV; ± 1 V; 1 to 5 V; ± 5 V; 0 to 10 V; ± 10 V Current 0 to 20 mA; 4 to 20 mA; ± 20 mA Resistors 0 to 600 Ω; 0 to 6 kΩ Bulb resistor (linear) Pt 100 climate; Pt 100 standard	± 10 V ± 20 mA 600 Ω Pt 100 standard		
<ul style="list-style-type: none"> Interference Suppression Temperature unit 	50 Hz; 60 Hz Degrees Celsius, degrees Fahrenheit, Kelvin*	50 Hz		

* Pt 100 standard only

4.20.2 Measuring Methods of the SM 331; AI 8 × 13 bits

Measuring methods

You can set the following measuring methods for the input channels:

- Voltage measurement
- Current measurement
- Resistance test

You perform the setting with the "measuring method" parameter in *STEP 7*.

Unused channels

Set the "measuring method" parameter for unused channels to "disabled". In this way you shorten the scan time of the module.

4.21 Analog Input Module SM 331; AI 8 × 12 bits; (6ES7 331-7KF02-0AB0)

Order number

6ES7 331-7KF02-0AB0

Characteristics

The analog input module SM 331; AI 8 × 12 bits has the following characteristic features:

- 8 inputs in 4 channel groups
- Measured-value resolution; settable per group (depending on the integration time set)
 - 9 bits + sign
 - 12 bits + sign
 - 14 bits + sign
- Measuring method selectable per channel group:
 - Voltage
 - Current
 - Resistors
 - Temperature
- Arbitrary measuring range selection per channel group
- Programmable diagnostics
- Programmable diagnostic interrupt
- Two channels with limit monitoring
- Programmable hardware interrupt when limit has been exceeded
- Isolated against the backplane bus interface
- Isolated against load voltage (except when at least one coding key is inserted in position D)

Resolution

The resolution of the measured value is a direct function of the integration time selected. In other words the longer the integration time for an analog input channel, the more accurate the resolution of the measured value will be (see Technical Specifications of the module and Table 4-6 on page 4-11).

Terminal connection diagram and block diagram of the SM 331; AI 8 × 12 bits

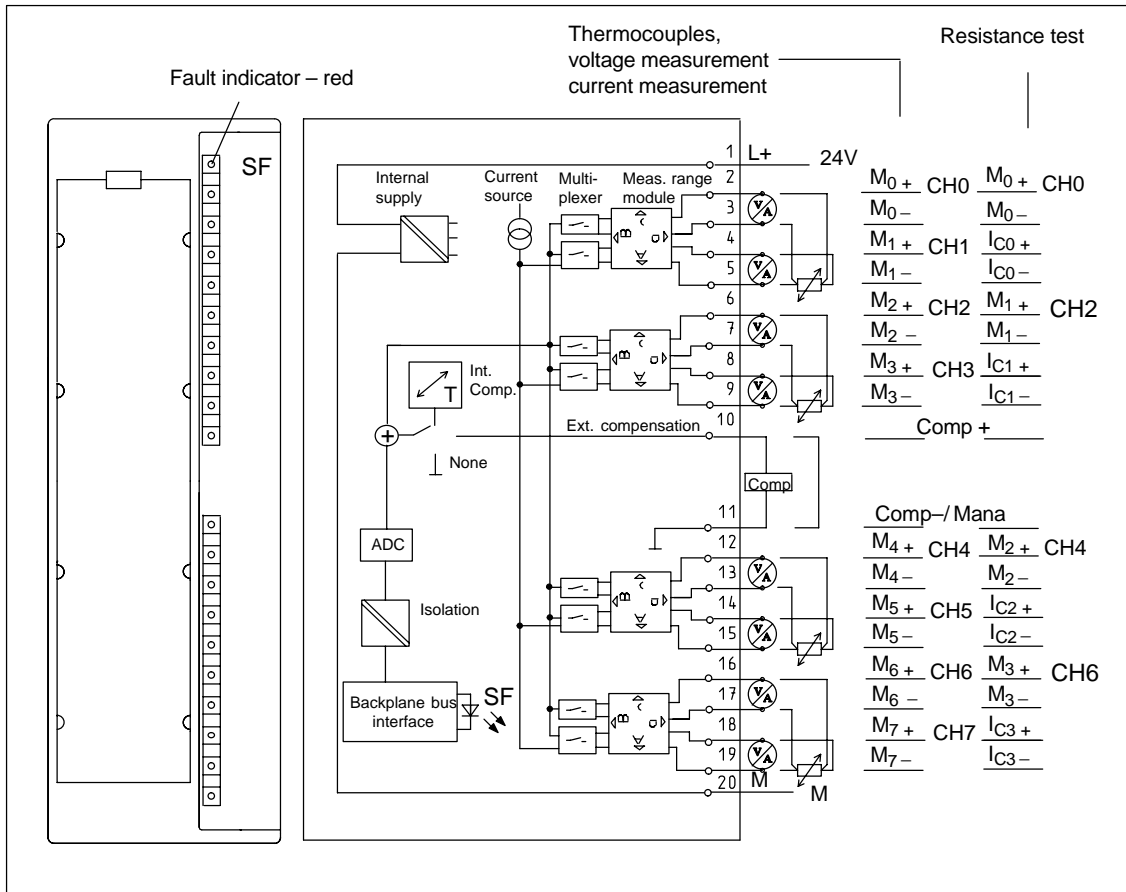

Figure 4-38 Module View and Block Diagram of the Analog Input Module SM 331; AI 8 × 12 bits

The input resistances depend on the measuring range selected (see Technical Specifications).

Technical specifications of the SM 331; AI 8 × 12 bits

Dimensions and Weight		Power dissipation of the module	typ. 1 W			
Dimensions W × H × D (in millimeters)	40 × 125 × 117	Analog Value Generation				
Weight	Approx. 250 g	Measuring principle	Integrating			
Data for Specific Module		Integration time/conversion time/ resolution (per channel)				
Supports clocked operation	No	<ul style="list-style-type: none"> Parameters can be assigned 	Yes			
Number of inputs	8	<ul style="list-style-type: none"> Integration time in milliseconds 	2.5	16 ² / ₃	20	100
<ul style="list-style-type: none"> For resistance-type sensor 	4	<ul style="list-style-type: none"> Basic conversion time including Integration time in milliseconds 	3	17	22	102
Length of cable	max. 200 m	Additional conversion time for measuring resistance, in ms or	1	1	1	1
<ul style="list-style-type: none"> Shielded 	max. 50 m at 80 mV and thermocouples	Additional conversion time for open-circuit monitoring, in ms or	10	10	10	10
Voltages, Currents, Potentials		Additional conversion time for measuring resistance and open-circuit monitoring, in ms	16	16	16	16
Rated supply voltage of the electronics L +	24 VDC	<ul style="list-style-type: none"> Resolution in bits (incl. overrange) 	9 bits	12 bits	12 bits	14 bits
<ul style="list-style-type: none"> Reverse polarity protection 	Yes	<ul style="list-style-type: none"> Noise suppression for frequency f1 in Hz 	400	60	50	10
Power supply of the transmitters		<ul style="list-style-type: none"> Basic execution time of the module, in ms (all channels enabled) 	24	136	176	816
<ul style="list-style-type: none"> Supply current 	max. 60 mA (per channel)	Smoothing of the measured values	None			
<ul style="list-style-type: none"> Short-circuit-proof 	Yes					
Constant current for resistance-type sensor	typ. 1.67 mA					
Isolation						
<ul style="list-style-type: none"> Between channels and backplane bus 	Yes					
<ul style="list-style-type: none"> Between channels and power supply of the electronics 	Yes					
Permitted potential difference	2.5 VDC					
<ul style="list-style-type: none"> Between inputs and M_{ANA} (U_{CM}) <ul style="list-style-type: none"> At signal = 0 V Not for 2-wire transmitter 						
<ul style="list-style-type: none"> Between the inputs (ECM) 	2.5 VDC					
<ul style="list-style-type: none"> Between M_{ANA} and M_{internal} (U_{ISO}) 	75 VDC / 60 VAC					
Insulation tested with	500 VDC					
Current consumption						
<ul style="list-style-type: none"> From the backplane bus 	max. 50 mA					
<ul style="list-style-type: none"> From the backplane bus L + 	max. 30 mA (without two-wire transmitter)					

Suppression of Interference, Limits of Error		Temperature error of internal compensation	
Noise suppression for $F = n \times (f1 \pm 1 \%)$, (f1 = interference frequency)		$\pm 1 \%$	
• Common-mode interference ($U_{CM} < 2.5 \text{ V}$)	> 70 dB	Status, Interrupts, Diagnostics	
• Series-mode noise (peak value of noise < nominal value of input range)	> 40 dB	Interrupts	
Crosstalk between the inputs	> 50 dB	• Hardware interrupt when limit has been exceeded	Programmable channels 0 and 2
Operational limit (in the entire temperature range, with reference to the input range)		• Diagnostic Interrupt	Programmable
• Voltage input	80 mV $\pm 1 \%$ 250 to 1000 mV $\pm 0.6 \%$ 2.5 to 10 V $\pm 0.8 \%$	Diagnostic functions	
• Current input	3.2 to 20 mA $\pm 0.7 \%$	• Group error display	Red LED (SF)
• Resistors	150Ω; 300Ω; 600 Ω $\pm 0, 7 \%$	• Diagnostics information read-out	Possible
• Thermocouple	Type E, N, J, K, L $\pm 1, 1 \%$	Data for Selecting a Sensor	
• Resistance thermometer	Pt 100/ Ni 100 $\pm 0, 7 \%$ Pt 100 climate $\pm 0, 8 \%$	Input range (rated values)/Input resistance	
Basic error (operational limit at 25 °C referred to input range)		• Voltage	$\pm 80 \text{ mV} /10 \text{ M}\Omega$ $\pm 250 \text{ mV} /10 \text{ M}\Omega$ $\pm 500 \text{ mV} /10 \text{ M}\Omega$ $\pm 1000 \text{ mV} /10 \text{ M}\Omega$ $\pm 2.5 \text{ V} /100\text{k}\Omega$ $\pm 5 \text{ V} /100\text{k}\Omega$ 1 to 5 V; $/100\text{k}\Omega$ $\pm 10 \text{ V} /100\text{k}\Omega$
• Voltage input	80 mV $\pm 0.7 \%$ 250 to 1000mV $\pm 0.4 \%$ 2.5 to 10 V $\pm 0.6 \%$	• Current	$\pm 3.2 \text{ mA} /25 \Omega$ $\pm 10 \text{ mA} /25 \Omega$ $\pm 20 \text{ mA} /25 \Omega$ 0 to 20 mA; $/25 \Omega$ 4 to 20 mA: $/25 \Omega$
• Current input	3.2 to 20 mA $\pm 0.5 \%$	• Resistors	150 Ω $/10 \text{ M}\Omega$ 300 Ω $/10 \text{ M}\Omega$ 600 Ω $/10 \text{ M}\Omega$
• Resistors	150Ω; 300Ω; 600 Ω $\pm 0.5 \%$	• Thermocouples	Type E, N, J, K, L $/10 \text{ M}\Omega$
• Thermocouple	Type E, N, J, K, L $\pm 0.7 \%$	• Resistance thermometer	Pt 100, Ni 100 $/10 \text{ M}\Omega$
• Resistance thermometer	Pt 100/ Ni 100 $\pm 0.5 \%$ Pt 100 climate $\pm 0.6 \%$	Maximum input voltage for voltage input (destruction limit)	
Temperature error (with reference to the input range)		max. 20 V continuous; 75 V for max. 1 s (duty factor 1:20)	
Linearity error (with reference to the input range)		Maximum input current for current input (destruction limit)	
Repeatability (in steady state at 25 °C referred to input range)		40 mA	

Connection of the sensor		Characteristic linearization	Parameters can be assigned
• For measuring voltage	Possible	• For thermocouples	Type E, N, J, K, L
• For measuring current		• For RTD	Pt 100 (standard, climate range) Ni 100 (standard, climate range)
As two-wire transmitter	Possible	Temperature compensation	Parameters can be assigned
As four-wire transmitter	Possible	• Internal temperature compensation	Possible
• For measuring resistance		• External temperature compensation with compensating box	Possible
With two-conductor connection	Possible	• Compensation for 0 °C comparison point temperature	Possible
With three-conductor connection	Possible	• Technical unit for temperature measurement	Degrees Celsius
With four-conductor connection	Possible		
• Load of the two-wire transmitter	max. 820 Ω		

4.21.1 Commissioning the SM 331; AI 8 × 12 bits

You set the mode of operation of the SM 331; AI 8 × 12 bits by means of measuring range modules on the module and in *STEP 7*.

Measuring range module

If necessary, the measuring range modules must be replugged to change the measuring method and the measuring range. The steps you have to perform to do this are described in detail in Section 4.4.

The corresponding table in Section 4.21.2 tells you which assignment you have to select for which measuring method and measuring range. In addition, the necessary settings are embossed on the module.

Default settings for measuring range module

The measuring range modules are preset to "B" (voltage; ± 10 V) when the module is supplied.

To use the following preset measuring methods and measuring ranges, you only have to change the measuring range module to the corresponding setting. Parameter assignment in *STEP 7* is not necessary.

Table 4-60 Default Settings of the SM 331; AI 8 × 12 bits Using Measuring Range Modules

Measuring Range Module Setting	Measuring Method	Measuring Range
A	Voltage	± 1000 mV
B	Voltage	± 10 V
C	Current, Four-wire transmitter	4 to 20 mA
D	Current, Two-wire transmitter	4 to 20 mA

Channel groups

The channels of the SM 331; AI 8 × 12 bits are arranged in four groups of two. You can only ever assign parameters to one channel group.

The analog input module SM 331; AI 8 × 12 bits has a measuring range module for each channel group.

The table below shows which channels are parameterized as a channel group in each case. You will need the channel group number to set the parameters in the user program with an SFC.

Table 4-62 Assignment of Channels of the SM 331; AI 8 × 12 bits to Channel Groups

Channels form one Channel Group each
Channel 0	Channel group 0
Channel 1	
Channel 2	Channel group 1
Channel 3	
Channel 4	Channel group 2
Channel 5	
Channel 6	Channel group 3
Channel 7	

Special characteristic of channel groups with resistance measurement

If you use the resistance measurement method, there is only one channel per channel group. The "2nd" channel of each group is used for current injection (I_C).

The measured value is obtained by accessing the "1st" channel of the group. The "2nd" channel of the group has the default carry value "7FFF_H".

Special characteristic of channel groups for hardware interrupts

You can set hardware interrupts in *STEP 7* for the channel groups 0 and 1. Note, however, that a hardware interrupt is set only for the first channel in the channel group in each case – in other words, for channel 0 or channel 2

Diagnostics

You will find the diagnostic messages that are grouped under the "group diagnosis" parameter in Table 4-46, on page 4-78.

4.21.2 Measuring Methods and Measuring Ranges of the SM 331; AI 8 × 12 bits

Measuring methods

You can set the following measuring methods for the input channels:

- Voltage measurement
- Current measurement
- Resistance test
- Temperature measurement

You perform the setting by means of the measuring range modules on the module and with the "measuring method" parameter in *STEP 7*.

Unused channels

You must short-circuit unused channels and connect them to M_{ANA} . In this way, you obtain an optimum interference immunity for the analog input module. Set the "measuring method" parameter for unused channels to "disabled". In this way you shorten the scan time of the module.

If you do not use the COMP input, you must short-circuit it also.

Special characteristics of unused channels for some measuring ranges

Since configured inputs can remain unused because of the channel group generation, you must take note of the following special characteristics of these inputs to enable the diagnostic functions on the used channels.

- **Measuring range 1 to 5 V:** Connect the unused input in parallel with a used input of the same channel group.
- **Current measurement, two-wire transmitter:**
There are two ways to use the channels:
 - a) Leave the unused input open and do not enable diagnostics for this channel group. Otherwise, if diagnostics are enabled, the analog module triggers a single diagnostic interrupt and the SF LED of the analog module comes on.
 - b) Connect the unused input with a resistance of 1.5 to 3.3 k Ω . You may then enable diagnostics for this channel group.
- **Current measurement 4 to 20 mA, four-wire transmitter:** Connect the unused input in series with an input of the same channel group.

Special characteristic when all channels are disabled

If you disable **all** input channels of the module and enable diagnostics when parameterizing the analog input module SM 331; AI 8 × 12 bits, the module does **not** indicate that the "external auxiliary voltage" is missing.

Measuring ranges

You perform the setting of the measuring ranges by means of the measuring range modules on the module and with the "measuring method" parameter in *STEP 7*.

Table 4-63 Measuring Ranges of the SM 331; AI 8 x 12 bits

Method Selected	Measuring Range (Type of Sensor)	Measuring Range Module Setting	Description
U: Voltage	± 80 mV ± 250 mV ± 500 mV ± 1000 mV	A	You will find the digitized analog values in Section 4.3.1 in the voltage measuring range
	± 2.5 V ± 5 V 1 to 5 V ± 10 V	B	
TC-I: Thermocouple (internal compensation) (thermovoltage measurement)	Type N [NiCrSi-NiSi] Type E [NiCr-CuNi] Type J [Fe-CuNi] Type K [NiCr-Ni]	A	You will find the digitized analog values in Section 4.3.1 in ± 80 mV the voltage measuring range
TC-E: Thermocouple (external compensation) (thermovoltage measurement)	Type L [Fe-CuNi]		
2DMU: Current (two-wire transmitter)	4 to 20 mA	D	You will find the digitized analog values in Section 4.3.1 in the current measuring range
4DMU: Current (four-wire transmitter)	± 3.2 mA ± 10 mA 0 to 20 mA 4 to 20 mA ± 20 mA	C	
R-4L: Resistors (four-conductor connection)	150 Ω 300 Ω 600 Ω	A	You will find the digitized analog values in Section 4.3.1 in the resistance measuring range

Table 4-63 Measuring Ranges of the SM 331; AI 8 x 12 bits

Method Selected	Measuring Range (Type of Sensor)	Measuring Range Module Setting	Description
TC-IL: Thermocouple (linear, internal compensation) (temperature measurement)	Type N [NiCrSi-NiSi] Type E [NiCr-CuNi] Type J [Fe-CuNi] Type K [NiCr-Ni] Type L [Fe-CuNi]	A	You will find the digitized analog values in Section 4.3.1 in the temperature range The characteristics are linearized: <ul style="list-style-type: none"> • Pt 100 to DIN IEC 751 • Ni 100 according to IEC DIN 43760 • Thermocouple to DIN 584, type L to DIN 43710.
TC-EL: Thermocouple (linear, external compensation) (temperature measurement)			
RTD-4L: Bulb resistor (linear, four-conductor connection) (temperature measurement)	Pt 100 climate Ni 100 climate Pt 100 standard Ni 100 standard	A	

Default settings

The default settings of the module in *STEP 7* are the "voltage" measuring method and the " $\pm 10\text{ V}$ " measuring range. You can use this combination of measuring method and measuring range without parameterizing the SM 331; AI 8 x 12 bits in *STEP 7*.

Wire-break check

The wire-break check is intended primarily for temperature measurements (thermocouples and bulb resistors).

Special characteristics of the wire-break check for the 4 to 20 mA measuring range

With a parameterized measuring range of 4 to 20 mA and **enabled wire-break check**, the analog input module enters wire-break in the diagnosis when a current falls below 3.6 mA.

If you have enabled diagnostics interrupt during configuration, the module additionally triggers a diagnostic interrupt.

If no diagnostic interrupt has been enabled, the illuminated SF LED is the only indication of the wire-break and you must evaluate the diagnostic bytes in the user program.

With a parameterized measuring range of 4 to 20 mA and **disabled wire-break check** and enabled diagnostic interrupt, the module triggers a diagnostic interrupt when the underflow is reached.

4.22 Analog Input Module SM 331; AI 8 × RTD (6ES7 331-7PF00-0AB0)

Order number

6ES7 331-7PF00-0AB0

Characteristics

The analog input module SM 331; AI 8 × RTD has the following characteristic features:

- 8 differential inputs for RTD resistance temperature detector in 4 channel groups
- Optional setting of the resistance thermometer type per channel group
- Rapid measured value updating for up to 4 channels
- Measured-value resolution 15 bits + sign (independent of integration time)
- Programmable diagnostics
- Programmable diagnostic interrupt
- 8 channels with limit monitoring
- Programmable hardware interrupt when limit has been exceeded
- Programmable end-of-scan-cycle interrupt
- Isolated against the backplane bus interface

Use of the module in the distributed peripheral ET 200M

When you use the SM 331; AI 8 × RTD in the distributed peripheral ET 200M, you must have one of the following IM 153 x:

- IM 153-1; ab 6ES7 153-1AA03-0XB0, E 01
- IM 153-2; ab 6ES7 153-2AA02-0XB0, E 05
- IM 153-2; ab 6ES7 153-2AB01-0XB0, E 04

Terminal connection diagram and block diagram of the SM 331; AI 8 × RTD

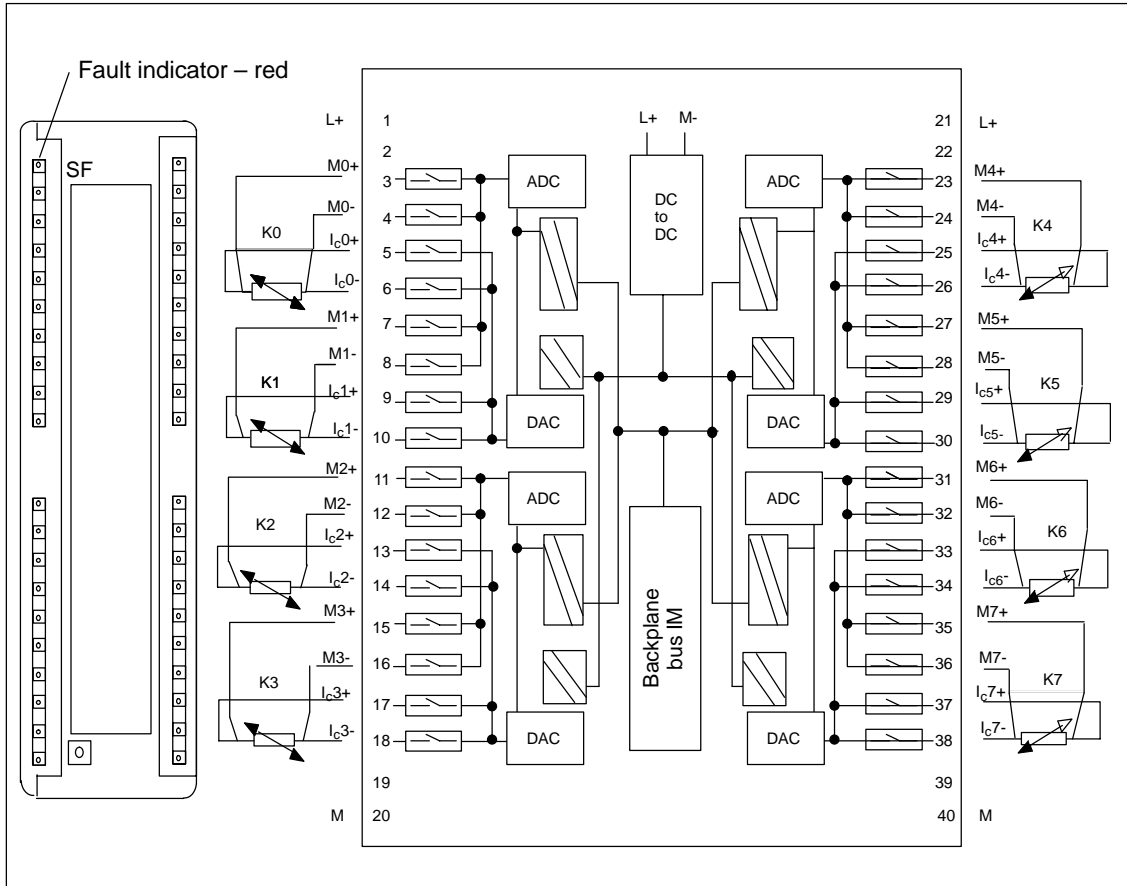

Figure 4-39 Module View and Block Diagram of the SM 331; AI 8 × RTD

Technical specifications of the SM 331; AI 8 × RTD

Dimensions and Weight		Analog Value Generation	
Dimensions W × H × D (in millimeters)	40 × 125 × 117	Measuring principle	Integrating
Weight	Approx. 272 g	Module filtering mode	8 channels, hardware
Data for Specific Module		Integration/conversion time/ resolution (per channel)	
Supports clocked operation	No	• Parameters can be assigned	Yes
Number of inputs	8	• Basic conversion time in ms	80
Length of cable		• Additional conversion time for measuring resistance, in ms	185*
• Shielded	max. 200 m	• Additional conversion time for open-circuit monitoring, in ms	100
Voltages, Currents, Potentials		• Resolution including sign	16 bits
Power rated voltage of the electronics L+	24 VDC	• Noise suppression for interference frequency f1 in Hz	400 / 60 / 50
• Reverse polarity protection	Yes	Smoothing of the measured values	None / low/ average/ high
Constant measured current for resistance-type sensor	max. 5 mA	Conversion time (per channel)	100 ms
Isolation		Basic response time of module (all channels enabled)	200 ms
• Between channels and backplane bus	Yes	Module filtering mode	8 channels, software
• Between channels and power supply of the electronics	Yes	Integration/conversion time/ resolution (per channel)	
• Between the channels in groups of	Yes 2	• Parameters can be assigned	Yes
Permitted potential difference		• Basic conversion time in ms	8 / 25 / 30
• Between the inputs (U _{CM})	75 VDC / 60 VAC	• Additional conversion time for measuring resistance, in ms	45 / 79 / 89*
• Between M _{ANA} and M _{internal} (U _{ISO})	75 VDC / 60 VAC	• Additional conversion time for open-circuit monitoring, in ms	20 / 37 / 42
Insulation tested with	500 VDC	• Resolution including sign	16 bits
Current consumption		• Noise suppression for interference frequency f1 in Hz	400 / 60 / 50
• From the backplane bus	max. 100 mA	Smoothing of the measured values	None / low/ average/ high
• From the power supply L+	max. 240 mA	Conversion time (per channel)	20 / 37 / 42 ms
Power dissipation of the module	typ. 4.6 W	Basic response time of module (all channels enabled)	40 / 79 / 84 ms

Module filtering mode	4 channels, hardware	Linearity error (with reference to the input range)	$\pm 0.02\%$
Integration/conversion time/resolution (per channel)		Repeat accuracy (in the steady state at 25 °C, referred to the input range)	$\pm 0.01\%$
<ul style="list-style-type: none"> Parameters can be assigned 	Yes	Status, Interrupts, Diagnostics	
<ul style="list-style-type: none"> Basic conversion time in ms 	3.3	Interrupts	
<ul style="list-style-type: none"> Additional conversion time for measuring resistance, in ms 	185*	<ul style="list-style-type: none"> Hardware interrupt 	Programmable (channels 0 – 7)
<ul style="list-style-type: none"> Additional conversion time for open-circuit monitoring, in ms 	85**	<ul style="list-style-type: none"> Diagnostic Interrupt 	Parameters can be assigned
<ul style="list-style-type: none"> Resolution including sign 	16 bits	Diagnostic functions	
<ul style="list-style-type: none"> Noise suppression for interference frequency f1 in Hz 	400 / 60 / 50	<ul style="list-style-type: none"> Group error display 	Red LED (SF)
Smoothing of the measured values	None / low/ average/ high	<ul style="list-style-type: none"> Diagnostic information can be displayed 	Possible
Basic response time of module (all channels enabled)	10 ms	Data for Selecting a Sensor	
Suppression of Interference, Limits of Error		Input range (rated values) input resistance	
Noise suppression for $f = n \times (f1 \pm 1\%)$, (f1 = interference frequency) n = 1.2, etc.		<ul style="list-style-type: none"> Resistance thermometer 	Pt 100, Pt 200, Pt 500, Pt 1000, Ni 100, Ni 120, Ni 200, Ni 500, Ni 1000, Cu 10
<ul style="list-style-type: none"> Common-mode interference ($U_{CM} < 60\text{ VAC}$) 	> 100 dB	<ul style="list-style-type: none"> Resistors 	150, 300, 600 Ω
<ul style="list-style-type: none"> Series-mode interference (peak value of interference < rated value of input range) 	> 90 dB	Maximum input voltage for voltage input (destruction limit)	
Crosstalk between the inputs	> 100 dB	35 VDC continuous; 75 VDC for max. 1 s (duty factor 1:20)	
Operational limit (over entire temperature range, referred to 0 to 60 °C input range)		Connection of the sensor	
<ul style="list-style-type: none"> Resistance thermometer 	$\pm 1.0\text{ }^{\circ}\text{C}$	<ul style="list-style-type: none"> For measuring resistance 	
<ul style="list-style-type: none"> Resistors 	$\pm 0.1\%$	<ul style="list-style-type: none"> With two-conductor connection 	Possible (without resistance correction)
Basic error (operational limit at 25°C, referred to input range)		<ul style="list-style-type: none"> With three-conductor connection 	Possible
<ul style="list-style-type: none"> Resistance thermometer 	$\pm 0.5\text{ }^{\circ}\text{C}$	<ul style="list-style-type: none"> With four-conductor connection 	Possible
<ul style="list-style-type: none"> Resistors 	$\pm 0.05\%$	Characteristic linearization	
Temperature error (with reference to the input range)	$\pm 0.005\text{ }^{\circ}\text{C/K}$	<ul style="list-style-type: none"> Resistance thermometer 	Pt 100, Pt 200, Pt 500, Pt 1000, Ni 100, Ni 120, Ni 200, Ni 500, Ni 1000, Cu 10 (standard and climatic range)
		<ul style="list-style-type: none"> Technical unit for temperature measurement 	Degrees Celsius; degrees Fahrenheit

* The resistance measurement for a three-conductor connection is performed every 5 minutes.

** Open-circuit monitoring in module filtering mode 4 Channels, Hardware is performed every 3 seconds.

4.22.1 Commissioning the SM 331; AI 8 × RTD

You set the mode of operation of the SM 331; AI 8 × RTD in *STEP 7*.

Parameter

You will find a description of the general procedure for assigning parameters to analog modules in Section 4.7.

Parameterization restrictions when using the SM 331; AI 8 x RTD with PROFIBUS masters that only support DPV0.

When you use the analog input module SM 331; AI 8 × RTD in an ET 200M PROFIBUS slave system with a PROFIBUS master which is not an S7 master, certain parameters are not permitted. Masters that are not S7 masters do not support hardware interrupts. So all the parameters associated with these functions are deactivated. The deactivated parameters are hardware interrupt enable, hardware restrictions and end-of-scan-cycle interrupt enable. All the other parameters are permitted.

An overview of the parameters that you can set and their default settings are shown in the table below.

Table 4-64 Parameters of the SM 331; AI 8 × RTD

Parameter	Value Range	Default Settings	Parameter Type	Scope
Enable <ul style="list-style-type: none"> • Diagnostic interrupt • Hardware interrupt upon limit violation • Hardware interrupt at end of cycle 	Yes/no Yes/no Yes/no	No No No	Dynamic	Module
Trigger for hardware interrupt <ul style="list-style-type: none"> • Upper limit value • Lower limit value 	32511 to -32512 -32512 to 32511	32767 -32768	Dynamic	Channel
Diagnostics <ul style="list-style-type: none"> • Group diagnostics • With wire-break check 	Yes/no Yes/no	No No	Static	Channel group

Table 4-64 Parameters of the SM 331; AI 8 × RTD, continued

Parameter	Value Range	Default Settings	Parameter Type	Scope
Measurement				
• Measuring method	Deactivated R-4L Resistance (four-conductor connection) R-3L Resistance, three-conductor connection RTD-4L Bulb resistor (linear, four-conductor connection) RTD-3L Bulb resistor (linear, three-conductor connection)	RTD-4L	Dynamic	Channel group
• Measuring range	Refer to Section 4.22.2 for the measuring ranges of the input channels that you can set.	Pt 100 climate 0.003850 (IPTS-68)		
• Temperature unit	Degrees Celsius; degrees Fahrenheit	Degrees Celsius	Dynamic	Module
• Module filtering mode	8 channels hardware filter 8 channels software filter 4 channels hardware filter	8 channels, hardware filter	Dynamic	Module
• Temperature coefficient for temperature measurement with bulb resistor (RTD)	Platinum (Pt) 0.003850 Ω/Ω/ °C 0.003916 Ω/Ω/ °C 0.003902 Ω/Ω/ °C 0.003920 Ω/Ω/ °C 0.003850 Ω/Ω/ °C (ITS-90) Nickel (Ni) 0.006180 Ω/Ω/ °C 0.006720 Ω/Ω/ °C Copper (Cu) 0.00427 Ω/Ω/ °C	0.003850	Dynamic	Channel group
• Interference suppression*	50/60/400 Hz; 400 Hz; 60 Hz; 50 Hz	50/60/400 Hz	Dynamic	Channel group
• Smoothing	None Low Average High	None	Dynamic	Channel group

* 50/60/400 Hz programmable only for modes 8 or 4-Channel Hardware Filter Modes; 50 Hz, 60 Hz or 400 Hz programmable only for mode 8-Channel Hardware Filter Mode

Channel groups

The channels of the SM 331; AI 8 × RTD are arranged in four groups of two. You can only ever assign parameters to one channel group.

The table below shows which channels are parameterized as a channel group in each case. You will need the channel group number to set the parameters in the user program with an SFC.

Table 4-65 Assignment of Channels of the SM 331; AI 8 × RTD to Channel Groups

Channels form one Channel Group each
Channel 0	Channel group 0
Channel 1	
Channel 2	Channel group 1
Channel 3	
Channel 4	Channel group 2
Channel 5	
Channel 6	Channel group 3
Channel 7	

Special characteristic of channel groups for hardware interrupts upon limit violation

You can set the upper and lower limits for each channel with hardware interrupts in *STEP 7*.

Module filtering mode

The SM 331; AI 8 × RTD operates in one of the following modes:

- "Hardware filter, 8 channels"
- "Software filter, 8 channels"
- "Hardware filter, 4 channels"

The operating mode affects the scan time of the module.

”Hardware filter 8 channels” mode

In ”Hardware filter 8 channels” mode, the analog input module SM331; AI 8 × RTD switches over between the two channels in each group. As the module contains four analog/digital converters (ADC), all four of the ADCs convert simultaneously for channels 0, 2, 4 and 6. Once the even-numbered channels have been converted all the ADCs simultaneously convert for the odd-numbered channels 1, 3, 5 and 7 (see Figure 4-40).

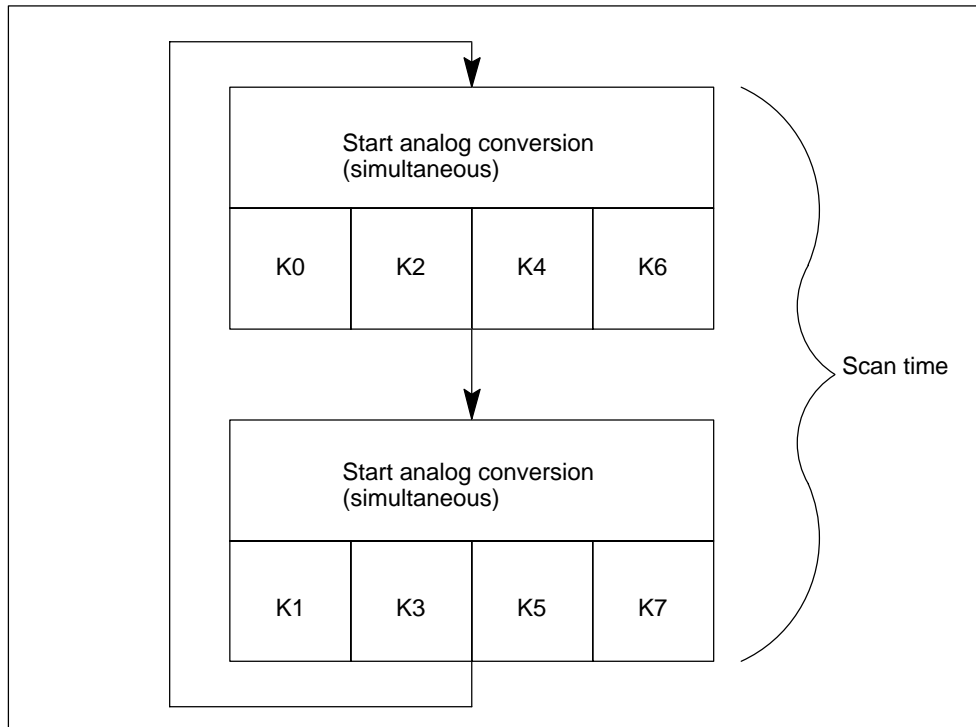

Figure 4-40 Hardware Filter 8 Channels Scan Time

Scan time of the module

In 8-channel hardware filter mode, the channel conversion time including the communication time of the analog input module SM 331; AI 8 × RTD is 85 ms. The module must then be switched over to the other channel in the group by means of opto-MOS relays. Opto-MOS relays need 12 ms to switch and settle. Each channel needs a time of 97 ms, so that the scan time is exactly 194 ms.

$$\text{Scan time} = (t_K + t_U) \times 2$$

$$\text{Scan time} = (85 \text{ ms} + 12 \text{ ms}) \times 2$$

Scan time = 194 ms

t_K : channel conversion time for one channel

t_U : time for switching to the other channel in the channel group

”Software filter 8 channels” mode

In ”Software filter 8 channels” mode, the analog/digital conversion occurs in exactly the same way as in ”hardware filter 8 channels” mode. That is to say, as the module contains four analog/digital converters (ADC), all four of the ADCs convert simultaneously for channels 0, 2, 4 and 6. Once the even-numbered channels are converted, all the ADCs convert simultaneously for the odd-numbered channels 1, 3, 5 and 7 (see Figure 4-41).

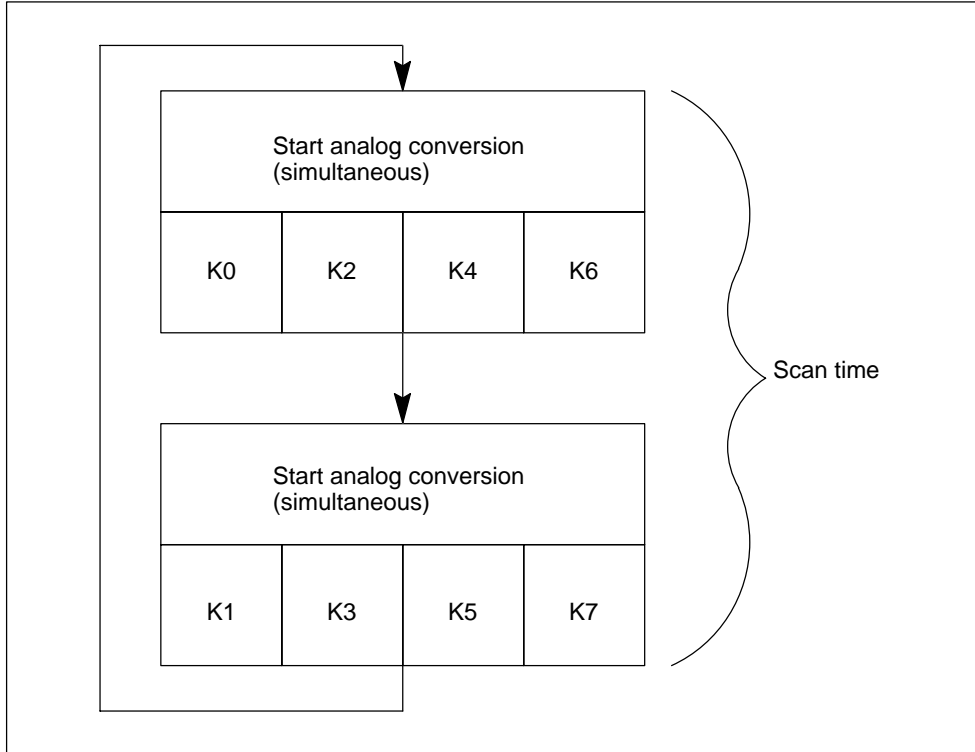

Figure 4-41 Software Filter 8 Channels Scan Time

Scan time of the module

The channel conversion time depends, however, on the programmed interference frequency suppression. When you set an interference frequency of 50 Hz, the channel conversion time including communication time is 30 ms. When you set an interference frequency of 60 Hz, the channel conversion time is 25 ms. When you set an interference frequency of 400 Hz, the channel conversion time is reduced to 8 ms. As with 8-channel hardware filter mode, the module must be switched over by means of opto MOS relays with a switchover time of 12 ms to the other channel of the group. This relationship is shown in the table that follows.

Table 4-66 Scan Times in "Software Filter, 8 Channels" Mode

Programmed Interference Frequency Suppression	Channel Scan Time*	Module Scan Time (All Channels)
50 Hz	42 ms	84 ms
60 Hz	37 ms	74 ms
400 Hz	20 ms	40 ms

* Channel scan time = channel conversion time + 12 ms switching time to the other channel in the channel group

Scan time in "Hardware Filter, 4 Channels" mode

In this mode, the module does not switch between the channels of the different groups. As the module contains four analog/digital converters (ADC), all four of the ADCs convert simultaneously for channels 0, 2, 4 and 6.

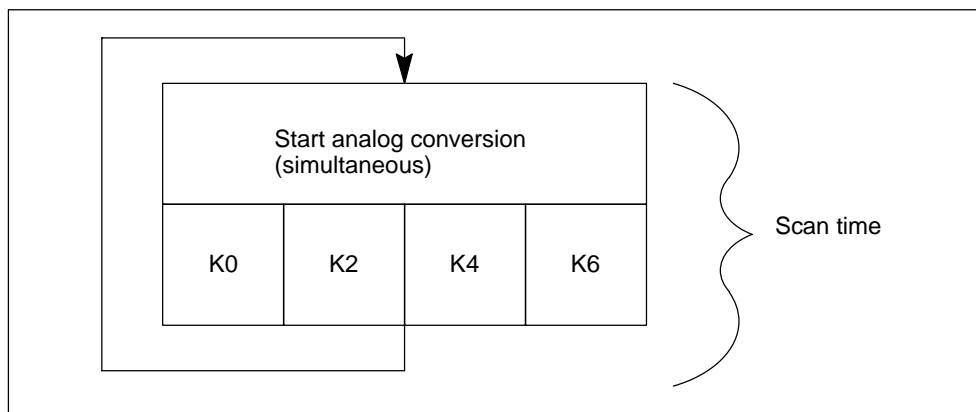

Figure 4-42 Hardware Filter 4 Channels Scan Time

Scan time of the module

In 4-channel hardware filter mode, the channel conversion time including the communication time of the analog input module SM 331; AI 8 × RTD is 10 ms. As the module does not switch over between the channels in a group, the channel scan time and the module scan time are the same: 10 ms.

Channel conversion time = channel scan time = module scan time = **10 ms**

Prolongation of the scan time with a wire-break check

The wire-break check is a software function of the module that is available in all operating modes.

In the 8-channel hardware and software filter operating modes, the scan time of the module is doubled, irrespective of the number of channels for which wire-break has been enabled.

In the 4-channel hardware filter operating mode, the module interrupts processing of the input data 170 ms and performs a wire-break check. In other words, each wire-break check prolongs the scan time of the module by 170 ms.

Smoothing of the measured values

You will find information that is generally applicable to the smoothing of analog values in Section 4.6.

Special characteristic with short-circuit to M or L

If you short an input channel to M or L, the module does not suffer any damage. The channel continues to issue valid data; neither is a diagnosis reported.

Diagnostics

You will find the diagnostic messages that are grouped under the "group diagnosis" parameter in Table 4-46, on page 4-78.

4.22.2 Measuring Methods and Measuring Ranges of the SM 331; AI 8 × RTD

Measuring methods

You can set the following measuring methods for the input channels:

- RTD 4-conductor measurement
- RTD 3-conductor measurement
- Resistor 4-conductor measurement
- Resistor 3-conductor measurement

You perform the setting with the "measuring method" parameter in *STEP 7*.

Unused channels

Set the "measuring method" parameter for unused channels to "disabled". In this way you shorten the scan time of the module.

You must terminate an unused channel of an enabled channel group with a nominal resistance in order to avoid diagnostic errors for the unused channel (refer to the block diagram, Figure 4-39, for the connection).

In the "4-Channel Hardware Filter" operating mode, termination is not necessary provided that you have disabled the unused channel groups. Channels 1, 3, 5 and 7 are not monitored in this mode.

Measuring ranges

You perform setting of the measuring ranges with the "measuring range" parameter in *STEP 7*.

Table 4-67 Measuring Ranges of the SM331;AI 8 × RTD

Method selected	Measuring Range	Description
Resistors: (Three-conductor/four-conductor terminal)	150 Ω 300 Ω 600 Ω	You will find the digital analog values in Section 4.3.1
Resistance RTD (Three-conductor/four-conductor terminal)	Pt 100 climate Pt 200 climate Pt 500 climate Pt 1000 climate Ni 100 climate Ni 120 climate Ni 200 climate Ni 500 climate Ni 1000 climate Cu 10 climate Pt 100 standard Pt 200 standard Pt 500 standard Pt 1000 standard Ni 100 standard Ni 120 standard Ni 200 standard Ni 500 standard Ni 1000 standard Cu 10 standard	

Special characteristic of parameter assignment to upper and lower limit values

The parameterizable limit values (triggers for hardware interrupt) differ for the AI 8 × RTD from the range of values shown in Table 4-64.

The reason for this is that numerical methods in the module software for evaluating the process variables prevent values up to 32511 from being reported in some cases. The process input value at which a hardware interrupt for an underflow or overflow occurs depends on the calibration factors for an individual channel and can vary between the lower limits shown in the Table below and 32511 (7EFF_H).

Limit values should not be set at values higher than the minimum potential limit values shown in the table below.

End-of-scan-cycle interrupt

By enabling the end-of-scan-cycle interrupt, you can synchronize a process with the conversion cycle of the module. The interrupt occurs when the conversion of all the enabled channels is complete.

Table 4-68 Content of the 4 Bytes with Additional Information from OB40 during a Hardware Interrupt or an End-of-Scan-Cycle Interrupt

Content of the 4 bytes with additional information		2 ⁷	2 ⁶	2 ⁵	2 ⁴	2 ³	2 ²	2 ¹	2 ⁰	Byte
Analog special markers	2 bits per channel to identify the range									
	Upper limit exceeded in channel	7	6	5	4	3	2	1	0	0
	Lower limit exceeded in channel	7	6	5	4	3	2	1	0	1
	End-of-scan-cycle event						X			2
	Unassigned bit									3

4.23 Analog Input Module SM 331; AI 8 × TC (6ES7 331-7PF10-0AB0)

Order number

6ES7 331-7PF10-0AB0

Characteristics

The analog input module SM 331; AI 8 × TC has the following characteristic features:

- 8 differential inputs for thermocouples (TC) in 4 channel groups
- Optional setting of the thermocouple type per channel group
- Rapid measured value updating for up to 4 channels
- Measured-value resolution 15 bits + sign (independent of integration time)
- Programmable diagnostics
- Programmable diagnostic interrupt
- 8 channels with limit monitoring
- Programmable hardware interrupt when limit has been exceeded
- Programmable end-of-scan-cycle interrupt
- Programmable reaction to open thermocouple
- Isolated against the backplane bus interface

Use of the module in the distributed peripheral ET 200M

When you use the SM 331; AI 8 × TC in the distributed peripheral ET 200M, you must have one of the following IM 153-x:

- IM 153-1; ab 6ES7 153-1AA03-0XB0, E 01
- IM 153-2; ab 6ES7 153-2AA02-0XB0, E 05
- IM 153-2; ab 6ES7 153-2AB01-0XB0, E 04

Terminal connection diagram and block diagram of the SM 331; AI 8 × TC

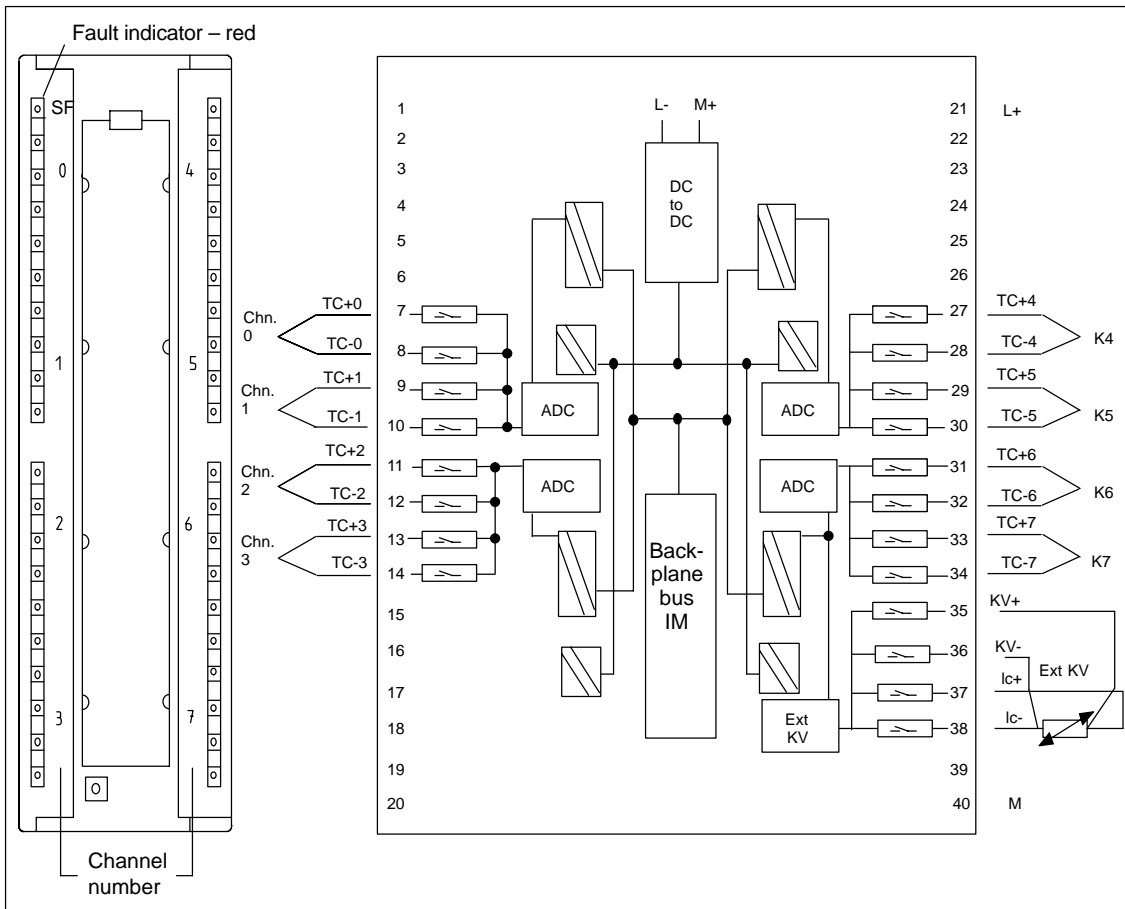

Figure 4-43 Module View and Block Diagram of the SM 331; AI 8 × TC

Technical specifications of the SM 331; AI 8 × TC

Dimensions and Weight		Analog Value Generation	
Dimensions W × H × D (in millimeters)	40 × 125 × 117	Measuring principle	Integrating
Weight	Approx. 272 g	Module filtering mode	8 channels, hardware
Data for Specific Module		Integration time/conversion time/ resolution (per channel)	
Supports clocked operation	No	• Parameters can be assigned	Yes
Length of cable		• Basic conversion time in ms	95
• Shielded	max. 100 m	• Additional conversion time for open-circuit monitoring, in ms	4
Voltages, Currents, Potentials		• Resolution including sign	16 bits
Power rated voltage of the electronics L+	24 VDC	• Noise suppression for interference frequency f1 in Hz	400/60/50
• Reverse polarity protection	Yes	Smoothing of the measured values	None / low/ average/ high
Constant measured current for resistance-type sensor	typ. 0.7 mA	Basic response time of module (all channels enabled)	190 ms
Isolation		Module filtering mode	8 channels, software
• Between channels and backplane bus	Yes	Integration time/conversion time/ resolution (per channel)	
• Between channels and power supply of the electronics	Yes	• Parameters can be assigned	Yes
• Between the channels in groups of	Yes 2	• Basic conversion time in ms	23/72/83
Permitted potential difference		• Additional conversion time for open-circuit monitoring, in ms	4
• Between the inputs (U _{CM})	75 VDC / 60 VAC	• Resolution including sign	16 bits
• Between M _{ANA} and M _{internal} (U _{ISO})	75 VDC 60 VAC	• Noise suppression for interference frequency f1 in Hz	400/60/50
Insulation tested with	500 VDC	Smoothing of the measured values	None / low/ average/ high
Current consumption		Basic response time of module (all channels enabled)	46/144/166 ms
• From the backplane bus	max. 100 mA		
• From supply voltage L+	max. 240 mA		
Power dissipation of the module	typ. 3.0 W		

Analog Value Generation (Cont'd)			
Measuring principle	Integrating		
Module filtering mode	4 channels, hardware		
Integration time/conversion time/ resolution (per channel)			
• Parameters can be assigned	Yes		
• Basic conversion time in ms	1.0		
• Additional conversion time for open-circuit monitoring, in ms	93 ¹⁾		
• Resolution including sign	16 bits		
• Noise suppression for frequency f1 in Hz	400/60/50		
Smoothing of the measured values	None / low/ average/ high values		
Basic response time of module (all channels enabled)	10 ms		
Suppression of Interference, Limits of Error			
Noise suppression for $f = n \times (f1 \pm 1\%)$, ($f1 =$ interference frequency) $n = 1, 2, \text{ etc.}$			
• Common-mode interference ($U_{cm} < 60 \text{ VAC}$)	> 100 dB		
• Series-mode interference (peak value of interference < rated value of input range)	> 90 dB ²⁾		
Crosstalk between the inputs	> 100 dB		
Operational limit (over entire temperature range, referred to 0 to 60 °C input range) Note: This limit does not cover the error cold connection point ³⁾			
• Thermocouple			
Type T	-200 °C to	+400 °C	±0.7 °C
	-230 °C to	-200 °C	±1.0 °C
Type U	-150 °C to	+400 °C	±0.9 °C
	-200 °C to	-150 °C	±1.2 °C
Type E	-200 °C to	+1000 °C	±1.2 °C
	-230 °C to	-200 °C	±1.5 °C
Type J	-150 °C to	+1200 °C	±1.4 °C
	-210 °C to	-150 °C	±1.7 °C
Type L	-150 °C to	+900 °C	±1.5 °C
	-200 °C to	-150 °C	±1.8 °C
Type K	-200 °C to	+1372 °C	±2.1 °C
	-230 °C to	-200 °C	±2.9 °C
Type N	-200 °C to	+1300 °C	±2.2 °C
	-230 °C to	-200 °C	±3.0 °C
Type R	+100 °C to	+1769 °C	±1.5 °C
	-50 °C to	+100 °C	±1.8 °C
Type S	+100 °C to	+1769 °C	±1.7 °C
	-50 °C to	+100 °C	±2.0 °C
Type B ⁴⁾	+200 °C to	+1820 °C	±2.3 °C
	+45 °C	+200 °C	±2.5 °C
Type C	+100 °C to	+2315 °C	±2.3 °C
	0 °C	+100 °C	±2.5 °C
Basic error (operational limit at 25°C, referred to input range)			
• Thermocouple			
Type T	-200 °C to	+400 °C	±0.2 °C
	-230 °C to	-200 °C	±0.5 °C
Type U	-150 °C to	+400 °C	±0.2 °C
	-200 °C to	-150 °C	±0.5 °C
Type E	-200 °C to	+1000 °C	±0.2 °C
	-230 °C to	-200 °C	±0.5 °C
Type J	-150 °C to	+1200 °C	±0.2 °C
	-210 °C to	-150 °C	±0.5 °C
Type L	-150 °C to	+900 °C	±0.2 °C
	-200 °C to	-150 °C	±0.5 °C
Type K	-200 °C to	+1372 °C	±0.2 °C
	-230 °C to	-200 °C	±1.0 °C
Type N	-200 °C to	+1300 °C	±0.2 °C
	-230 °C to	-200 °C	±1.0 °C
Type R	+100 °C to	+1769 °C	±0.2 °C
	-50 °C to	+100 °C	±0.5 °C
Type S	+100 °C to	+1769 °C	±0.2 °C
	-50 °C to	+100 °C	±0.5 °C
Type B ⁴⁾	+200 °C to	+1820 °C	±0.3 °C
	+45 °C to	+200 °C	±0.5 °C
Type C	+100 °C to	+2315 °C	±0.3 °C
	0 °C	+100 °C	±0.5 °C

Temperature error (with reference to the input range)	±0.005%/K
Linearity error (with reference to the input range)	± 0.02%
Repeat accuracy (in the steady state at 25 °C, referred to the output range ³⁾)	±0.01%
Status, Interrupts, Diagnostics	
Interrupts	
• Hardware interrupt	Parameters can be assigned (channels 0 to 7)
• Diagnostic interrupt	Parameters can be assigned
Diagnostic functions	
• Group error display	Red LED (SF)
• Diagnostics information read-out	Possible

Data for Selecting a Sensor	
Input ranges (rated values)/ input resistance	
• Thermocouples	Type B, C, N, E, R, S, J, L, T, K, U
Maximum input voltage for voltage input (destruction limit)	20 VDC continuous; 75 VDC for max. 1 s (duty factor 1:20)
Characteristic linearization	Parameters can be assigned
Temperature compensation	Parameters can be assigned
• Internal temperature compensation	Possible
• External temperature compensation with Pt 100	Possible
• Compensation for 0°C comparison point temperature	Possible
• Compensation for 50°C comparison point temperature	Possible
• Technical unit for temperature measurement	Degrees Celsius/ degrees Fahrenheit

- 1) Open-circuit monitoring in 4 channels, Hardware operating mode is performed every 3 seconds.
- 2) Series-mode rejection in 8 channels, software mode is reduced as follows:
 50 Hz > 70 db
 60 Hz > 70 db
 400 Hz > 80 db
- 3) The operational limit comprises only the basic error of the analog input at Ta = 25 °C and the total temperature error. The total error must cover the error for the compensation of the cold connection point. Internal compensation of the cold connection point = max. 1.5 °C
 External compensation of the cold connection point = accuracy of the used external RTD is +0.1 °C
 External compensation of the cold connection point, where the connection point is held at 0 °C or 50 °C = accuracy of the connection point temperature control.
- 4) Because of the slight rise over the range of approx. 0 °C to 85 °C, the lack of compensation of the comparison point temperature only has a negligible effect on a type B thermocouple. If there is no compensation and the measuring method "Compensation to 0 °C" is set, the deviation in the type B thermocouple during temperature measurement is: 200 °C to 1802 °C <0.5 °C

4.23.1 Commissioning the SM 331; AI 8 × TC

You set the mode of operation of the SM 331; AI 8 × TC bits in *STEP 7*.

Parameter

You will find a description of the general procedure for assigning parameters to analog modules in Section 4.7.

Parameterization restrictions when using the analog input module SM 331; AI 8 x TC with PROFIBUS masters that only support DPV0.

When you use the analog input module SM 331; AI 8 × TC in an ET 200M PROFIBUS slave system with a PROFIBUS master which is not an S7 master, certain parameters are not permitted. Masters that are not S7 masters do not support hardware interrupts. So all the parameters associated with these functions are deactivated. The deactivated parameters are hardware interrupt enable, hardware restrictions and end-of-scan-cycle interrupt enable. All the other parameters are permitted.

An overview of the parameters that you can set and their default settings are shown in the table below.

Table 4-69 Parameters of the SM 331; AI 8 × TC

Parameter	Value Range	Default Settings	Parameter Type	Scope
Enable <ul style="list-style-type: none"> • Diagnostic Interrupt • Hardware interrupt upon limit violation • Hardware interrupt at end of cycle 	Yes/no Yes/no Yes/no	No No No	Dynamic	Module
Trigger for hardware interrupt <ul style="list-style-type: none"> • Upper limit value • Lower limit value 	32511 to -32512 -32512 to 32511	32767 -32768	Dynamic	Channel
Diagnostics <ul style="list-style-type: none"> • Group diagnostics • With wire-break check 	Yes/no Yes/no	No No	Static	Channel group

Table 4-69 Parameters of the SM 331; AI 8 × TC

Parameter	Value Range	Default Settings	Parameter Type	Scope
Measurement				
• Measuring method	Deactivated TC-IL Thermocouple (linear, internal comparison) TC-EL Thermocouple (linear, external comparison) TC-L00C thermocouple (linear, ref. temperature 0°C) TC-L50C thermocouple (linear, ref. temp. 50°C)	TC-IL	Dynamic	Channel group
• Measuring range	For the settable measuring ranges of the input channels, please refer to the individual module description.	Type K		
• Reaction to open thermocouple	Overflow; underflow	Overflow		
• Temperature unit	Degrees Celsius; degrees Fahrenheit	Degrees Celsius	Dynamic	Module
• Module filtering mode	8 channels hardware filter 8 channels software filter 4 channels hardware filter	8 channels, hardware filter	Dynamic	Module
• Interference suppression*	50/60/400 Hz; 400 Hz; 60 Hz; 50 Hz;	50/60/400 Hz	Dynamic	Channel group
• Smoothing	None Low Average High	None	Dynamic	Channel group

* 50/60/400 Hz programmable only for modes 8 or 4-Channel Hardware Filter Modes;
50 Hz, 60 Hz or 400 Hz programmable only for mode 8-Channel Hardware Filter Mode

Channel groups

The channels of the SM 331; AI 8 × TC are arranged in four groups of two. You can only ever assign parameters to one channel group.

The table below shows which channels are parameterized as a channel group in each case. You will need the channel group number to set the parameters in the user program with an SFC.

Table 4-70 Assignment of Channels of the SM 331; AI 8 × TC to Channel Groups

Channels form one Channel Group each
Channel 0	Channel group 0
Channel 1	
Channel 2	Channel group 1
Channel 3	
Channel 4	Channel group 2
Channel 5	
Channel 6	Channel group 3
Channel 7	

Special characteristic of channel groups for hardware interrupts upon limit violation

You can set the upper and lower limits for each channel with hardware interrupts in *STEP 7*.

Module filtering mode

The SM 331; AI 8 × TC operates in one of the following modes:

- "Hardware Filter, 8 Channels"
- "Software Filter, 8 Channels"
- "Hardware Filter, 4 Channels"

The operating mode affects the scan time of the module.

”Hardware filter 8 channels” mode

In 8-channel hardware filter mode, the analog input module SM331; AI 8 × TC switches over between the two channels in each group. As the module contains four analog/digital converters (ADC), all four of the ADCs convert simultaneously for channels 0, 2, 4 and 6. Once the even-numbered channels have been converted all the ADCs simultaneously convert for the odd-numbered channels 1, 3, 5 and 7 (see Figure 4-35).

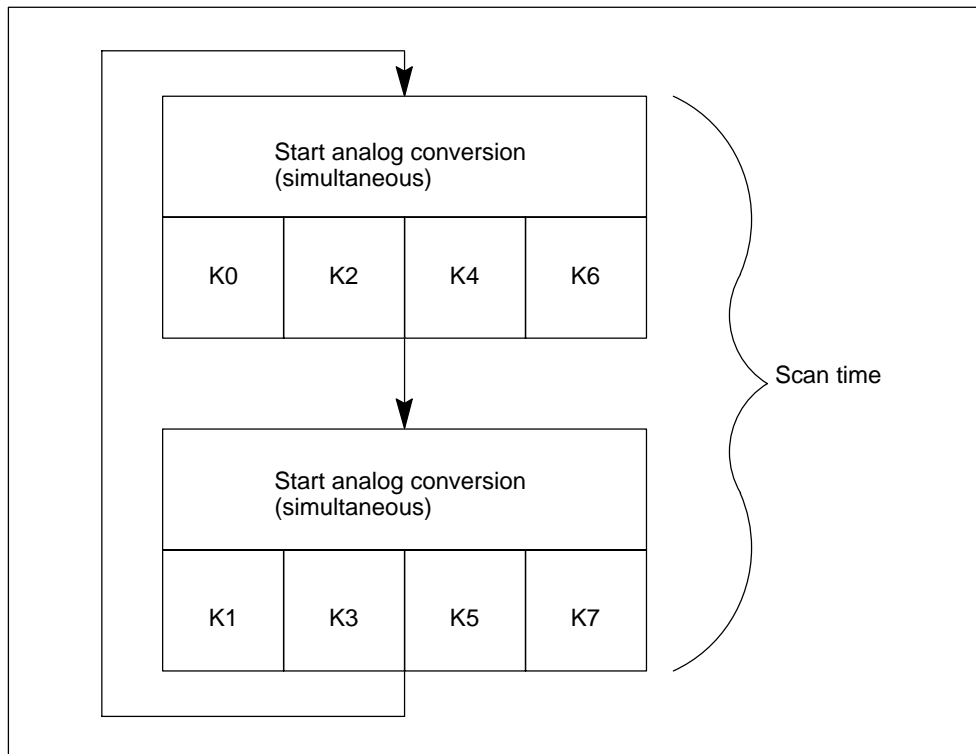

Figure 4-44 Hardware Filter 8 Channels Scan Time

Scan time in the mode

In 8-channel hardware filter mode, the channel conversion time including the communication time of analog input module SM331; AI 8 × TC is 91 ms. The module must then be switched over to the other channel in the group by means of opto-MOS relays. Opto-MOS relays need 7 ms to switch and settle. Each channel needs a time of 98 ms, so that the scan time is exactly 196 ms.

$$\text{Scan time} = (t_K + t_U) \times 2$$

$$\text{Scan time} = (91 \text{ ms} + 7 \text{ ms}) \times 2$$

$$\text{Scan time} = \mathbf{196 \text{ ms}}$$

t_K : channel conversion time for one channel

t_U : time for switching to the other channel in the channel group

”Software filter 8 channels” mode

In 8-channel software filter mode, the analog input module SM331; AI 8 × TC switches over between the two channels in each group. As the module contains four analog/digital converters (ADC), all four of the ADCs convert simultaneously for channels 0, 2, 4 and 6. Once the even-numbered channels have been converted all the ADCs simultaneously convert for the odd-numbered channels 1, 3, 5 and 7 (see Figure 4-45).

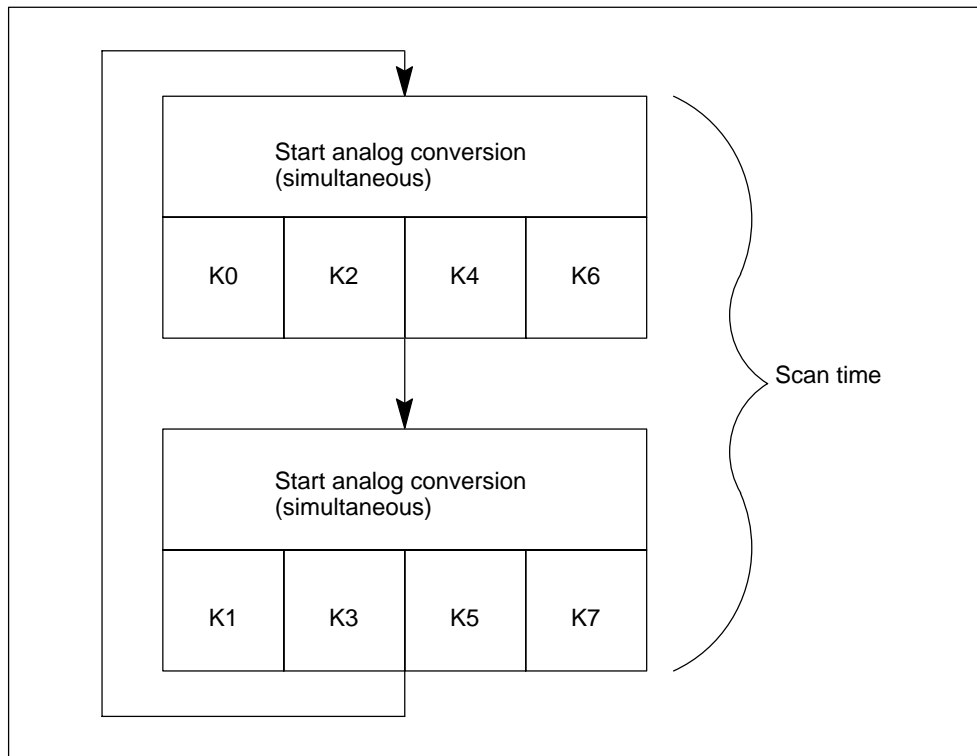

Figure 4-45 Software Filter 8 Channels Scan Time

Scan time of the module

In the 8-channel software filter mode of analog input module SM331; AI 8 × TC, the channel conversion time is guided by the interference frequency set. When you set an interference frequency of 50 Hz, the channel conversion time including communication time is 76 ms. When you set an interference frequency of 60 Hz, the channel conversion time is 65 ms. When you set an interference frequency of 400 Hz, the channel conversion time is reduced to 16 ms. As with 8-channel hardware filter mode, the module must be switched over by means of opto MOS relays with a switchover time of 7 ms to the other channel of the group. Table 4-71 shows the scan time of the module at a certain interference frequency.

Table 4-71 Scan Times in "Software Filter, 8 Channels" Mode

Programmed interference frequency suppression	Channel scan time*	Module scan time (all channels)
50 Hz	83 ms	166 ms
60 Hz	72 ms	144 ms
400 Hz	23 ms	46 ms

* Channel scan time = channel conversion time + 7 ms switching time to the other channel in the channel group

"Hardware filter 4 channels" mode

In 4-channel hardware filter mode, the analog input module SM331; AI 8 × TC does not switch over between the channels of the individual groups. As the module contains four analog/digital converters (ADC), all four of the ADCs convert simultaneously for channels 0, 2, 4 and 6.

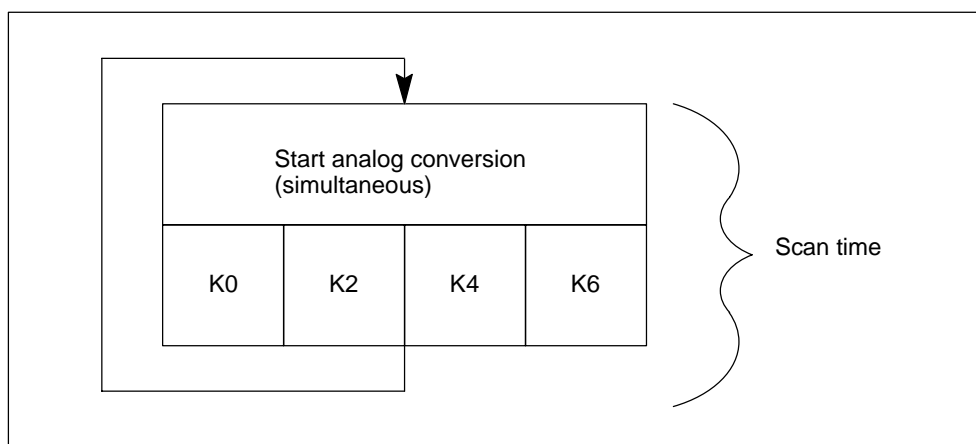

Figure 4-46 Hardware Filter 4 Channels Scan Time

Scan time of the module

In 4-channel hardware filter mode, the channel conversion time including the communication time of analog input module SM331; AI $8 \times TC$ is 10 ms. As the module does not switch over between the channels in a group, the channel scan time and the module scan time are the same: 10 ms.

Channel conversion time = channel scan time = module scan time = **10 ms**

Prolongation of the scan time with a wire-break check

The wire-break check is a software function of the module that is available in all operating modes.

In the 8-channel hardware and software filter operating mode prolongs the scan time of the module by 4 ms, irrespective of the number of channels for which wire-break has been enabled.

In the 4-channel hardware filter operating mode, the module interrupts processing of the input data 170 ms and performs a wire-break check. In other words, each wire-break check prolongs the scan time of the module by 93 ms.

Smoothing of the measured values

You will find information that is generally applicable to the smoothing of analog values in Section 4.6.

Special characteristic with short-circuit to M or L

If you short an input channel to M or L, the module does not suffer any damage. The channel continues to issue valid data; neither is a diagnosis reported.

Diagnostics

You will find the diagnostic messages that are grouped under the "group diagnosis" parameter in Table 4-46, on page 4-78.

4.23.2 Measuring Methods and Measuring Ranges of the SM 331; AI 8 × TC

Measuring methods

You can set the following measuring methods for the input channels:

- Thermocouple, linearization with reference temperature 0 °C
- Thermocouple, linearization with reference temperature 50 °C
- Thermocouples, linearization with internal comparison
- Thermocouple, linearization with external comparison

You perform the setting with the "measuring method" parameter in *STEP 7*.

Unused channels

Set the "measuring method" parameter for unused channels to "disabled". In this way you shorten the scan time of the module.

You must terminate an unused channel in an enabled channel group to avoid diagnostic errors for the unused channel. To do this, short the Plus input and Minus input of the channel.

In the "4-Channel Hardware Filter" operating mode, termination is not necessary provided that you have disabled the unused channel groups. Channels 1, 3, 5 and 7 are not monitored in this mode.

Measuring ranges

You perform setting of the measuring ranges with the "measuring range" parameter in *STEP 7*.

Table 4-72 Measuring Ranges of the SM 331;AI 8 × TC

Method Selected	Measuring Range	Description
TC-L00C: (thermocouple, linear, reference temperature 0 °C)	Type B	You will find the digitized analog values in Section 4.3.1 in the temperature range
	Type C	
	Type E	
TC-L50C: (thermocouple, linear, reference temperature 50 °C)	Type J	
	Type K	
	Type L	
TC-IL: (thermocouple, linear, internal compensation)	Type N	
	Type R	
	Type S	
TC-EL: (thermocouple, linear, external compensation)	Type T	
	Type U	

Special characteristic of parameter assignment to upper and lower limit values

The parameterizable limit values (triggers for hardware interrupt) differ for the AI 8 × TC from the range of values shown in Table 4-69.

The reason for this is that numerical methods in the module software for evaluating the process variables prevent values up to 32511 from being reported in some cases. The process input value at which a hardware interrupt for an underflow or overflow occurs depends on the calibration factors for an individual channel and can vary between the lower limits shown in the Table below and 32511 (7EFF_H).

Limit values should not be set at values higher than the minimum potential limit values shown in the tables below.

Table 4-73 Minimum Possible Upper and Lower Limit Values of SM 331; AI 8 x TC in in °C

Thermo-couple	Minimum Possible Upper Limit Value			Minimum Possible Lower Limit Value		
	in °C	Dec.	Hex.	in °C	Dec.	Hex.
Type B	1820.1	18201	471A _H	0	0	0
Type C	---	---	---	---	---	---
Type E	---	---	---	---	---	---
Type J	1200.1	12001	2EE1 _H	<-210.0	<-2100	< F7CC _H
Type K	1372.1	13721	3599 _H	<-270.0	<-2700	< F574 _H
Type L	900.1	9001	2329 _H	<-200.0	<-2000	< F830 _H
Type N	---	---	---	---	---	---
Type R, S	1769.1	1769.1	451B _H	-50.1	-501	FE0B _H
Type T	400.1	4001	0FA1 _H	<-270.0	<-2700	< F574 _H
Type U	600.1	6001	1771 _H	<-200.0	<-2000	< F830 _H

Table 4-74 Minimum Possible Upper and Lower Limit Values of SM 331; AI 8 x TC in in °F

Thermo-couple	Minimum Possible Upper Limit Value			Minimum Possible Lower Limit Value		
	in °F	Dec.	Hex.	in °F	Dec.	Hex.
Type B	2786.6	27866	6CDA _H	0	0	0
Type C	---	---	---	---	---	---
Type E	---	---	--	---	---	--
Type J	2192.2	21922	55A2 _H	<-346.0	<-3460	< F27C _H
Type K	2501.8	25018	61BA _H	<454.0	<-4540	<EE44 _H
Type L	1652.2	16522	408A _H	<-328.0	<-3280	F330 _H
Type N	---	---	---	---	---	---
Type R, S	3216.4	3216.4	7DA4 _H	-58.2	-582	FDBA _H
Type T	752.2	7522	1062 _H	<454.0	<-4540	<EE44 _H
Type U	1112.2	11122	2B72 _H	<-328.0	<-3280	< F330 _H

End-of-scan-cycle interrupt

By enabling the end-of-scan-cycle interrupt, you can synchronize a process with the conversion cycle of the module. The interrupt occurs when the conversion of all the enabled channels is complete.

Table 4-75 Content of the 4 Bytes with Additional Information from OB40 during a Hardware Interrupt or an End-of-Scan-Cycle Interrupt

Content of the 4 bytes with additional information		2 ⁷	2 ⁶	2 ⁵	2 ⁴	2 ³	2 ²	2 ¹	2 ⁰	Byte
Analog special markers	2 bits per channel to identify the range									
	Upper limit exceeded in channel	7	6	5	4	3	2	1	0	0
	Lower limit exceeded in channel	7	6	5	4	3	2	1	0	1
	End-of-scan-cycle event						X			2
	Unassigned byte									3

4.24 Analog Input Module SM 331; AI 2×12 bits; (6ES7 331-7KBx2-0AB0)

Order number: "Standard module"

6ES7 331-7KB02-0AB0

Order number: "SIMATIC Outdoor module"

6ES7 331-7KB82-0AB0

Characteristics

The analog input module SM 331; AI 2×12 bits has the following characteristic features:

- Two inputs in one channel group
- Measured-value resolution (depending on the integration time set)
 - 9 bits + sign
 - 12 bits + sign
 - 14 bits + sign
- Measuring method selectable per channel group:
 - Voltage
 - Current
 - Resistors
 - Temperature
- Arbitrary measuring range selection per channel group
- Programmable diagnostics
- Programmable diagnostic interrupt
- One channel with limit monitoring
- Programmable hardware interrupt when limit has been exceeded
- Isolated against the backplane bus interface
- Isolated against load voltage (except when at least one coding key is inserted in position D)

Resolution

The resolution of the measured value is a direct function of the integration time selected. In other words the longer the integration time for an analog input channel, the more accurate the resolution of the measured value will be (see Technical Specifications of the module and Table 4-6 on page 4-11).

Terminal connection diagram and block diagram of the SM 331; AI 2 × 12 bits

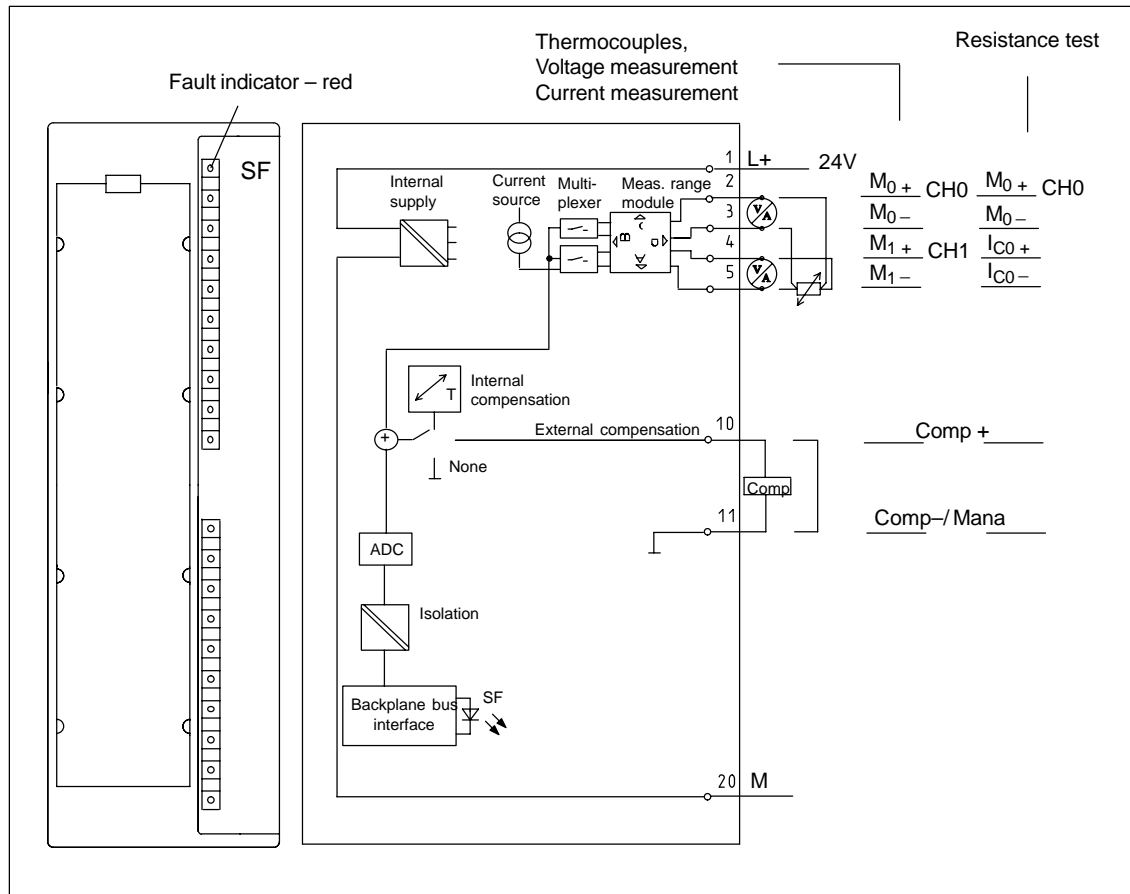

Figure 4-47 Module View and Block Diagram of the Analog Input Module SM 331; AI 2 × 12 bits

The input resistances depend on the measuring range selected (refer to the technical specifications for the module).

Technical specifications of the SM 331; AI 2 × 12 bits

Dimensions and Weight		Analog Value Generation				
Dimensions W × H × D (in millimeters)	40 × 125 × 117	Measuring principle	Integrating			
Weight	Approx. 250 g	Integration time/conversion time/ resolution (per channel)				
Data for Specific Module		<ul style="list-style-type: none"> Parameters can be assigned 	Yes			
Supports clocked operation	No	<ul style="list-style-type: none"> Integration time in milliseconds 	2.5	16 ² / ₃	20	100
Number of inputs	2	<ul style="list-style-type: none"> Basic conversion time including Integration time in milliseconds 	3	17	22	102
<ul style="list-style-type: none"> For resistance-type sensor 	1	Additional conversion time for measuring resistance, in ms or	1	1	1	1
Length of cable	max. 200 m	Additional conversion time for open-circuit monitoring, in ms or	10	10	10	10
<ul style="list-style-type: none"> Shielded 	max. 50 m at 80 mV and thermocouples	Additional conversion time for measuring resistance and open-circuit monitoring, in ms	16	16	16	16
Voltages, Currents, Potentials		<ul style="list-style-type: none"> Resolution in bits (incl. overrange) 	9 bits	12 bits	12 bits	14 bits
Rated supply voltage of the electronics L +	24 VDC	<ul style="list-style-type: none"> Noise suppression for frequency f1 in Hz 	400	60	50	10
<ul style="list-style-type: none"> Reverse polarity protection 	Yes	<ul style="list-style-type: none"> Basic execution time of the module, in ms (all channels enabled) 	6	34	44	204
Power supply of the transmitters		Smoothing of the measured values	None			
<ul style="list-style-type: none"> Supply current 	max. 60 mA (per channel)					
<ul style="list-style-type: none"> Short-circuit-proof 	Yes					
Constant current for resistance-type sensor	typ. 1.67 mA					
Isolation						
<ul style="list-style-type: none"> Between channels and backplane bus 	Yes					
<ul style="list-style-type: none"> Between channels and power supply of the electronics 	Yes					
Permitted potential difference	2.5 VDC					
<ul style="list-style-type: none"> Between inputs and M_{ANA} (U_{CM}) – At signal = 0 V – Not for 2-wire transmitter 						
<ul style="list-style-type: none"> Between M_{ANA} and M_{internal} (U_{ISO}) 	75 VDC / 60 VAC					
Insulation tested with	500 VDC					
Current consumption						
<ul style="list-style-type: none"> From the backplane bus 	max. 50 mA					
<ul style="list-style-type: none"> From the backplane bus L + 	max. 30 mA (without two-wire transmitter)					
Power dissipation of the module	typ. 1.3 W					

Suppression of interference, Limits of Error		Temperature error of internal compensation	
Noise suppression for $f = n \times (f_1 \pm 1 \%)$, ($f_1 =$ interference frequency) $n=1.2\dots$		$\pm 1 \%$	
Status, Interrupts, Diagnostics			
Interrupts			
• Common-mode interference ($U_{CM} < 2.5 \text{ V}$)	> 70 dB	• Hardware interrupt when limit has been exceeded	Programmable channel 0
• Series-mode noise (peak value of noise < nominal value of input range)	> 40 dB	• Diagnostic Interrupt	Programmable
Crosstalk between the inputs	> 50 dB	Diagnostic functions	Programmable
Operational limit (in the entire temperature range, with reference to the input range)		• Group error display	Red LED (SF)
• Voltage input	80 mV	• Diagnostics information read-out	Possible
	250 to 1000mV	Data for Selecting a Sensor	
	2.5 to 10 V	Input range (rated values)/Input resistance	
• Current input	3.2 to 20 mA	• Voltage	$\pm 80 \text{ mV} /10 \text{ M}\Omega$
• Resistors	150 Ω ; 300 Ω ; 600 Ω		$\pm 250 \text{ mV} /10 \text{ M}\Omega$
• Thermocouple	Type E, N, J, K, L		$\pm 500 \text{ mV} /10 \text{ M}\Omega$
• Resistance thermometer	Pt 100/ Ni 100		$\pm 1000 \text{ mV} /10 \text{ M}\Omega$
	Pt 100 climate		$\pm 2.5 \text{ V} /100\text{k}\Omega$
Basic error (operational limit at 25 °C referred to input range)			$\pm 5 \text{ V} /100\text{k}\Omega$
• Voltage input	80 mV		1 to 5 V; /100k Ω
	250 to 1000mV		$\pm 10 \text{ V} /100\text{k}\Omega$
	2.5 to 10 V	• Current	$\pm 3.2 \text{ mA} /25 \Omega$
• Current input	3.2 to 20 mA		$\pm 10 \text{ mA} /25 \Omega$
• Resistors	150 Ω ; 300 Ω ; 600 Ω		$\pm 20 \text{ mA} /25 \Omega$
• Thermocouple	Type E, N, J, K, L		0 to 20 mA; /25 Ω
• Resistance thermometer	Pt 100/ Ni 100		4 to 20 mA: /25 Ω
	Pt 100 climate	• Resistors	150 Ω /10 M Ω
Temperature error (with reference to the input range)			300 Ω /10 M Ω
	$\pm 0.005 \text{ \%}/\text{K}$		600 Ω /10 M Ω
Linearity error (with reference to the input range)		• Thermocouples	Type E, N, J, K, L /10 M Ω
	$\pm 0.05 \text{ \%}$	• Resistance thermometer	Pt 100, Ni 100 /10 M Ω
Repeatability (in steady state at 25 °C referred to input range)		Maximum input voltage for voltage input (destruction limit)	max. 20 V continuous; 75 V for max. 1 s (duty factor 1:20)
	$\pm 0.05 \text{ \%}$	Maximum input current for current input (destruction limit)	40 mA

Connection of the sensor		Characteristic linearization	Parameters can be assigned
• For measuring voltage	Possible	• For thermocouples	Type E, N, J, K, L
• For measuring current		• For RTD	Pt 100 (standard, climate range) Ni 100 (standard, climate range)
As two-wire transmitter	Possible	Temperature compensation	Parameters can be assigned
As four-wire transmitter	Possible	• Internal temperature compensation	Possible
• For measuring resistance	Possible	• External temperature compensation with compensating box	Possible
With two-conductor connection	Possible	• Compensation for 0 °C comparison point temperature	Possible
With three-conductor connection	Possible	• Technical unit for temperature measurement	Degrees Celsius
With four-conductor connection			
• Load of the two-wire transmitter	max. 820 Ω		

4.24.1 Commissioning the SM 331; AI 2 × 12 bits

You set the mode of operation of the SM 331; AI 2 × 12 bits by means of a measuring range module on the module and in *STEP 7*.

Measuring range module

If necessary, the measuring range module must be replugged to change the measuring method and the measuring range. The steps you have to perform to do this are described in detail in Section 4.4.

The corresponding table in Section 4.24.2 tells you which assignment you have to select for which measuring method and measuring range. In addition, the necessary settings are embossed on the module.

Default settings for measuring range module

The measuring range module is preset to "B" (voltage; ± 10 V) when the module is supplied.

To use the following preset measuring methods and measuring ranges, you only have to change the measuring range module to the corresponding setting. Parameter assignment in *STEP 7* is not necessary.

Table 4-76 Default Settings of the SM 331; AI 2 × 12 bits Using Measuring Range Module

Measuring Range Module Setting	Measuring Method	Measuring Range
A	Voltage	± 1000 mV
B	Voltage	± 10 V
C	Current, four-wire transmitter	4 to 20 mA
D	Current, two-wire transmitter	4 to 20 mA

Parameter

You will find a description of the general procedure for assigning parameters to analog modules in Section 4.7.

An overview of the parameters that you can set and their default settings are shown in the table below.

Table 4-77 Parameters of the SM 331; AI 2 × 12 bits

Parameter	Value Range	Default Settings	Parameter Type	Scope
Enable <ul style="list-style-type: none"> Diagnostic interrupt Hardware interrupt upon limit violation 	Yes/no Yes/no	No No	Dynamic	Module
Trigger for hardware interrupt <ul style="list-style-type: none"> Upper limit value Lower limit value 	32511 to –32512 –32512 to 32511	–	Dynamic	Channel
Diagnostics <ul style="list-style-type: none"> Group diagnostics With wire-break check 	Yes/no Yes/no	No No	Static	Channel group

Table 4-77 Parameters of the SM 331; AI 2 × 12 bits

Parameter	Value Range	Default Settings	Parameter Type	Scope
Measurement				
• Measuring method	Deactivated U Voltage 4DMU Current (four-wire transmitter) 2DMU Current (two-wire transmitter) R-4L Resistance (four-conductor connection) RTD-4L Bulb resistor (linear, four-conductor connection) TC-I Thermocouple (internal comparison) TC-E Thermocouple (external comparison) TC-IL Thermocouple (linear, internal comparison) TC-EL Thermocouple (linear, external comparison)	U	Dynamic	Channel or channel group
• Measuring range	Refer to Section 4.24.2 for the measuring ranges of the input channels that you can set.	± 10 V		
• Interference suppression	400 Hz; 60 Hz; 50 Hz; 10 Hz	50 Hz		

Channel groups

The two channels of the analog input module SM 331; AI 2 × 12 bits are combined to a channel group. You can only ever assign parameters to the channel group.

The SM 331; AI 2 × 12 bits has a measuring range module for the channel group 0.

Special characteristic of channel groups with resistance measurement

If you use the resistance measurement method, the analog input module has only one channel. The "2nd" channel is used for current injection (I_C).

The measured value is obtained by accessing the "1st" channel. The "2nd" channel has the default carry value "7FFF_H".

Special characteristic of channel groups for hardware interrupts

You can set a hardware interrupt in *STEP 7* for the channel group. Note, however, that a hardware interrupt is set only for the first channel in the channel group in each case – in other words, for channel 0.

Diagnostics

You will find the diagnostic messages that are grouped under the "group diagnosis" parameter in Table 4-46, on page 4-78.

4.24.2 Measuring Methods and Measuring Ranges of the SM 331; AI 2 × 12 bits

Measuring methods

You can set the following measuring methods for the input channels:

- Voltage measurement
- Current measurement
- Resistance test
- Temperature measurement

You perform the setting by means of the measuring range module on the module and with the "measuring method" parameter in *STEP 7*.

Unused channels

You must short-circuit unused channels and connect them to M_{ANA} . In this way, you obtain an optimum interference immunity for the analog input module. Set the "measuring method" parameter for unused channels to "disabled". In this way you shorten the scan time of the module.

If you do not use the COMP input, you must short-circuit it also.

Special characteristics of unused channels for some measuring ranges

Since configured inputs can remain unused because of the channel group generation, you must take note of the following special characteristics of these inputs to enable the diagnostic functions on the used channels.

- **Measuring range 1 to 5 V:** Connect the unused input in parallel with a used input of the same channel group.
- **Current measurement, two-wire transmitter:**
There are two ways to use the channels:
 - a) Leave the unused input open and do not enable diagnostics for this channel group. Otherwise, if diagnostics are enabled, the analog module triggers a single diagnostic interrupt and the SF LED of the analog module comes on.
 - b) Connect the unused input with a resistance of 1.5 to 3.3 kΩ. You may then enable diagnostics for this channel group.
- **Current measurement 4 to 20 mA, four-wire transmitter:** Connect the unused input in series with an input of the same channel group.

Measuring ranges

You perform the setting of the measuring ranges by means of the measuring range module on the module and with the "measuring method" parameter in *STEP 7*.

Table 4-78 Measuring Ranges of the SM 331; AI 2 x 12 bits

Method Selected	Measuring Range (Type of Sensor)	Measuring Range Module Setting	Description
U: Voltage	± 80 mV ± 250 mV ± 500 mV ± 1000 mV	A	You will find the digitized analog values in Section 4.3.1 in the voltage measuring range
	± 2.5 V ± 5 V 1 to 5 V ± 10 V	B	
TC-I: Thermocouple (internal compensation) (thermovoltage measurement)	Type N [NiCrSi-NiSi] Type E [NiCr-CuNi] Type J [Fe-CuNi] Type K [NiCr-Ni]	A	You will find the digitized analog values in Section 4.3.1 in ± 80 mV the voltage measuring range
TC-E: Thermocouples (external compensation) (thermovoltage measurement)	Type L [Fe-CuNi]		

Table 4-78 Measuring Ranges of the SM 331; AI 2 x 12 bits

Method Selected	Measuring Range (Type of Sensor)	Measuring Range Module Setting	Description
2DMU: Current (2-wire transmitter)	4 to 20 mA	D	You will find the digitized analog values in Section 4.3.1 in the current measuring range
4DMU: Current (4-wire transmitter)	± 3.2 mA ± 10 mA 0 to 20 mA 4 to 20 mA ± 20 mA	C	
R-4L: Resistors (four-conductor connection)	150 Ω 300 Ω 600 Ω	A	You will find the digitized analog values in Section 4.3.1 in the resistance measuring range
TC-IL: Thermocouples (linear, internal compensation) (temperature measurement)	Type N [NiCrSi-NiSi] Type E [NiCr-CuNi] Type J [Fe-CuNi] Type K [NiCr-Ni] Type L [Fe-CuNi]	A	You will find the digitized analog values in Section 4.3.1 in the temperature range The characteristics are linearized: <ul style="list-style-type: none"> • Pt 100 to DIN IEC 751 • Ni 100 according to IEC DIN 43760 • Thermocouple to DIN 584, type L to DIN 43710.
TC-EL: Thermocouples (linear, external compensation) (temperature measurement)	Type N [NiCrSi-NiSi] Type E [NiCr-CuNi] Type J [Fe-CuNi] Type K [NiCr-Ni] Type L [Fe-CuNi]	A	
RTD-4L: Bulb resistor (linear, four-conductor connection), (temperature measurement)	Pt 100 climate Ni 100 climate Pt 100 standard Ni 100 standard	A	

Default settings

The default settings of the module in *STEP 7* are the "voltage" measuring method and the "± 10 V" measuring range. You can use this combination of measuring method and measuring range without parameterizing the SM 331; AI 8 × 12 bits in *STEP 7*.

Wire-break check

The wire-break check is intended primarily for temperature measurements (thermocouples and bulb resistors).

Special characteristics of the wire-break check for the 4 to 20 mA measuring range

With a parameterized measuring range of 4 to 20 mA and **enabled wire-break check**, the analog input module enters wire-break in the diagnosis when a current falls below 3.6 mA.

If you have enabled diagnostics interrupt during configuration, the module additionally triggers a diagnostic interrupt.

If no diagnostic interrupt has been enabled, the illuminated SF LED is the only indication of the wire-break and you must evaluate the diagnostic bytes in the user program.

With a parameterized measuring range of 4 to 20 mA and **disabled wire-break check** and enabled diagnostic interrupt, the module triggers a diagnostic interrupt when the underflow is reached.

4.25 Analog Output Module SM 332; AO 8 × 12 bits; (6ES7 332-5HF00-0AB0)

Order number

6ES7 332-5HF00-0AB0

Characteristics

The analog input module SM 332; AO 8 × 12 bits has the following characteristic features

- 8 outputs in 8 channel groups
- The individual output channels can be programmed as
 - Voltage outputs
 - Current outputs
- Resolution 12 bits
- Programmable diagnostics
- Programmable diagnostic interrupt
- Isolated against backplane bus interface and load voltage

**Terminal connection and block diagram of analog output module SM 332;
AO 8 × 12 bits**

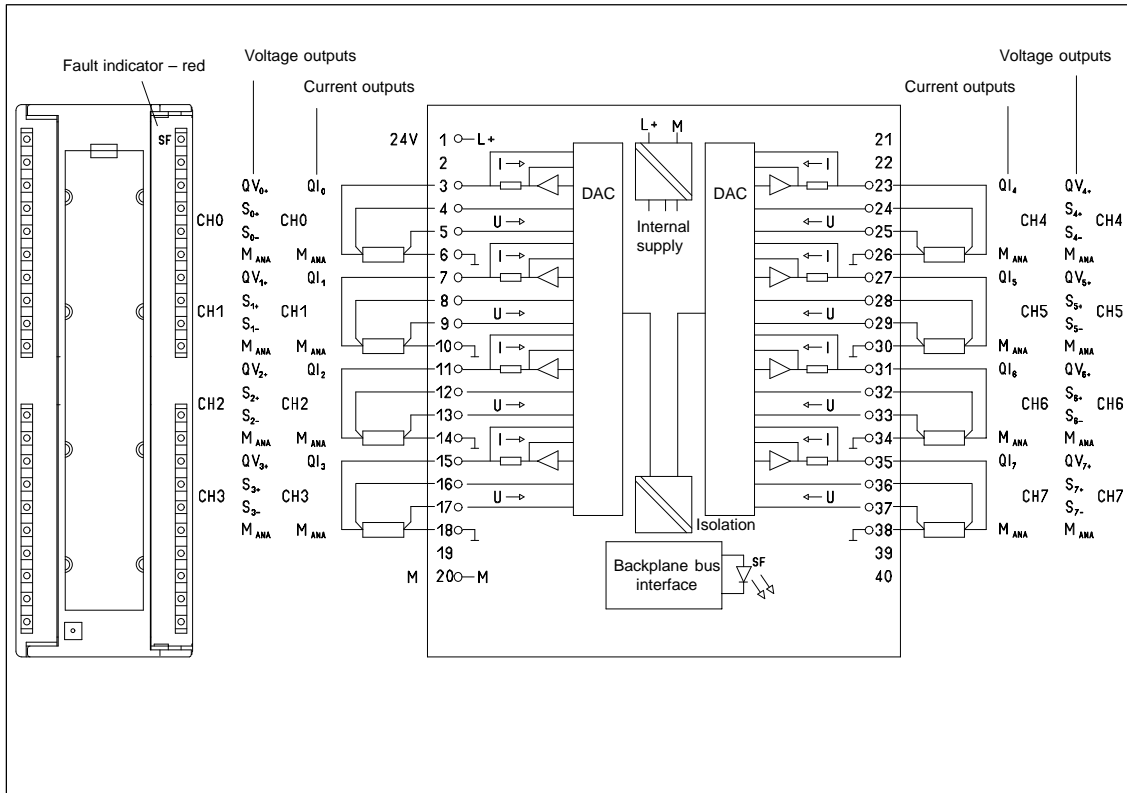

Figure 4-48 Module View and Block Diagram of the Analog Output Module SM 332; AO 8 × 12 bits

Technical specifications of the SM 332; AO 8 × 12 bits

Dimensions and Weight		Analog Value Generation	
Dimensions W × H × D (in millimeters)	40 × 125 × 117	<ul style="list-style-type: none"> Resolution including sign ± 10 V; ± 20 mA; 4 to 20 mA; 1 to 5 V 0 to 10 V; 0 to 20 mA; Conversion time (per channel) 	<ul style="list-style-type: none"> 11 bits + sign 12 bits max. 0.8 ms
Weight	Approx. 272 g	Settling time	
Data for Specific Module		<ul style="list-style-type: none"> For resistive load For capacitive load For inductive load 	<ul style="list-style-type: none"> 0.2 ms 3.3 ms 0.5 ms (1 mH) 3.3 ms (10 mH)
Supports clocked operation	No	Suppression of Interference, Limits of Error	
Number of inputs	8	<ul style="list-style-type: none"> Crosstalk between the outputs 	> 40 dB
Length of cable		Operational limit (in the entire temperature range, with reference to the output range)	
<ul style="list-style-type: none"> Shielded 	max. 200 m	<ul style="list-style-type: none"> Voltage outputs Current outputs 	<ul style="list-style-type: none"> ±0.5 % ±0.6 %
Voltages, Currents, Potentials		Basic error (operational limit at 25 °C referred to the output range)	
Rated load voltage L+	24 VDC	<ul style="list-style-type: none"> Output voltage Output current Temperature error (with reference to the output range) Linearity error (with reference to the output range) Repeat accuracy (in the steady state at 25°C, referred to the output range) Output ripple; band width 0 to 50 kHz (with reference to the output range) 	<ul style="list-style-type: none"> ± 0.4 % ± 0.5 % ±0.002 % /K + 0.05 % ±0.05 % ± 0.05 %
<ul style="list-style-type: none"> Reverse polarity protection 	Yes		
Isolation			
<ul style="list-style-type: none"> Between channels and backplane bus Between channels and power supply of the electronics Between the channels Between channels and load voltage L+ 	<ul style="list-style-type: none"> Yes Yes No Yes 		
Permitted potential difference			
<ul style="list-style-type: none"> Between S⁻ and M_{ANA} (U_{CM}) Between M_{ANA} and M_{internal} (U_{ISO}) 	<ul style="list-style-type: none"> 3 VDC 75 VDC / 60 VAC 		
Insulation tested with	500 VDC		
Current consumption			
<ul style="list-style-type: none"> From the backplane bus From supply voltage L+ (no load) 	<ul style="list-style-type: none"> max. 100 mA max. 340 mA 		
Power dissipation of the module	typically 6.0 W		

Status, Interrupts, Diagnostics	
Interrupts	
• Diagnostic Interrupt	Programmable
Diagnostic functions	
• Group error display	Parameters can be assigned
• Diagnostics information read-out	Red LED (SF) Possible
Data for Selecting an Actuator	
Output ranges (rated values)	
• Voltage	± 10 V 0 to 10 V 1 to 5 V
• Current	± 20 mA 0 to 20 mA 4 to 20 mA
Impedance (in the nominal output range)	
• For voltage outputs	min. 1 kΩ
– capacitive load	max. 1 μF
• For current outputs	max. 500 Ω
– At $U_{CM} < 1 V$	max. 600 Ω
– For inductive load	max. 10 mH
Voltage outputs	
• Short-circuit protection	Yes
• Short-circuit current	max. 25 mA
Current outputs	
• No-load voltage	max. 18 V
Destruction limit for voltages/currents connected from outside	
• Voltage at outputs to M_{ANA}	max. 18 V continuous; 75 V for max. 1 s (mark-to-space ratio 1:20)
• Current	max. 50 mA DC
Connection of actuators	
• For voltage output	
Four-conductor connection	Possible
• For current output	
Two-conductor connection	Possible

4.25.1 Commissioning the SM 332; AO 8 × 12 bits

Note

If the load voltage (L+) is switched off and on, this may result in incorrect output values at the output for approx. 10 ms.

Parameter

You will find a description of the general procedure for assigning parameters to analog modules in Section 4.7.

You will find an overview of the programmable parameters and their default values in Table 4-42, on page 4-47.

Assigning parameters to channels

You can configure each output channel of the SM 332; AO 8 × 12 bits individually. You can thus assign separate parameters for each output channel.

When you set the parameters with SFCs in the user program, the parameters are assigned to channel groups. Every output channel of the SM 332; AO 8 × 12 bits is assigned to a channel group in this instance – in other words, for example output channel 0 = channel group 0.

Note

If you modify output ranges when the analog output module SM 332; AO 8 × 12 bits is in operation, incorrect intermediate values may arise across the output.

Diagnostics

You will find the diagnostic messages that are grouped under the "group diagnosis" parameter in Table 4-47, on page 4-79.

4.25.2 Output Ranges of the Analog Output Module SM 332; AO 8 × 12 bits

Connecting the analog outputs

You can connect the outputs as voltage or current outputs, or disable them. You perform connection of the outputs with the "output type" parameter in *STEP 7*.

Unused channels

So that unused output channels of the SM 332; AO 8 × 12 bits remain de-energized, you must set the "output type" parameter to "disabled" and leave the terminal open.

Output ranges

You program the output ranges for voltage and current outputs in *STEP 7*.

Table 4-79 Output Ranges of the Analog Output Module der SM 332; AO 8 × 12 bits

Selected Type of Output	Output Range	Description
Voltage	1 to 5 V 0 to 10 V ± 10 V	You will find the digital analog values in Section 4.3.2 in the voltage and current output ranges
Current	0 to 20 mA 4 to 20 mA ± 20 mA	

Default settings

The default settings of the module are "Voltage" for the output type and "± 10 V" for the output range. You can use this combination of output type and output range without parameterizing the SM 332; AO 8 × 12 bits in *STEP 7*.

Wire-break check

The analog output module SM 332; AO 8 × 12 bits carries out a wire-break check only for current outputs.

Short-circuit test

The analog output module SM 332; AO 8 × 12 bits carries out a short-circuit test only for voltage outputs.

4.26 Analog Output Module SM 332; AO 4 × 16 bits; (6ES7 332-7ND01-0AB0)

Order number

6ES7 332-7ND01-0AB0

Characteristics

The analog output module SM 332; AO 4 × 16 bits has the following characteristic features:

- 4 outputs in 4 channel groups
- The individual output channels can be programmed as
 - Voltage outputs
 - Current outputs
- Resolution of 16 bits
- Supports clocked operation
- Programmable diagnostics
- Programmable diagnostic interrupt
- Programmable substitute value output
- Galvanic isolation between:
 - Backplane bus interface and analog output channel
 - The different analog output channels
 - Analog output and L+, M
 - Backplane bus interface and L+, M

**Terminal connection and block diagram of analog output module SM 332;
AO 4 × 16 bits**

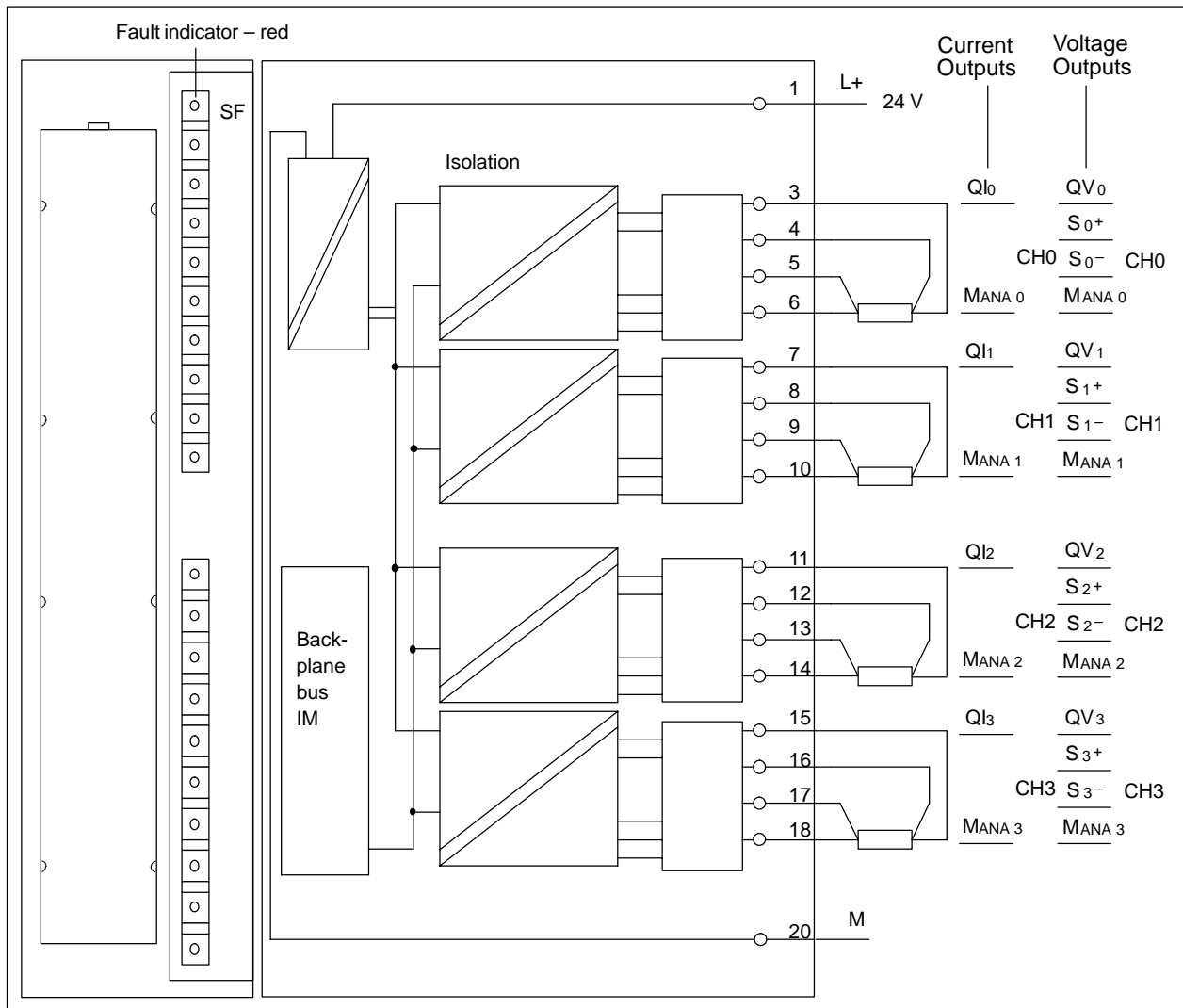

Figure 4-49 Module View and Block Diagram of the SM 332; AO 4 x 16 bits

Technical specifications of the SM 332; AO 4 × 16 bits

Dimensions and Weight		Analog Value Generation	
Dimensions W × H × D (in millimeters)	40 × 125 × 117	Resolution (including overrange)	15 bits + sign
Weight	Approx. 220 g	<ul style="list-style-type: none"> • 1 to 5 V • 4 to 20 mA 	13 bits 14 bits
Data for Specific Module		Conversion time	max. 1.5 ms
Supports clocked operation	Yes	Settling time	
Number of outputs	4	<ul style="list-style-type: none"> • For resistive load • For capacitive load • For inductive load 	0.2 ms 1.0 ms 0.2 ms
Length of cable		Suppression of interference, Limits of Error	
<ul style="list-style-type: none"> • Shielded 	max. 200 m	Crosstalk between outputs	> 100 dB
Voltages, Currents, and Potentials		Operational limit (in the entire temperature range, with reference to the output range)	
Rated load voltage L+	24 VDC	<ul style="list-style-type: none"> • Voltage outputs • Current outputs 	±0.12% ±0.18%
<ul style="list-style-type: none"> • Reverse polarity protection 	Yes	Basic error (operational limit at 25° C, referred to output range)	
Isolation		<ul style="list-style-type: none"> • Voltage outputs • Current outputs 	±0.02% ±0.02%
<ul style="list-style-type: none"> • Between channels and backplane bus • Between channels and power supply of the electronics • Between the channels • Between channels and load voltage L+ 	Yes Yes Yes Yes	Temperature error (with reference to the output range)	±0.001%
Permitted potential difference		Linearity error (with reference to the output range)	±0.004%
<ul style="list-style-type: none"> • Between the outputs (ECM) • Between M_{ANA} and M_{internal} (U_{ISO}) 	200 VDC / 120 VAC 200 VDC / 120 VAC	Repeat accuracy (in the steady state at 25° C, referred to the output range)	±0.002 %
Insulation tested with	500 VDC	Output ripple; band width 0 to 50 kHz (with reference to the output range)	±0.05 %
Current consumption		Status, Interrupts, Diagnostics	
<ul style="list-style-type: none"> • From the backplane bus • From the load voltage L+ (no load) 	max. 60 mA max. 240 mA	Interrupts	
Power dissipation of the module	typ. 3 W	<ul style="list-style-type: none"> • Diagnostic Interrupt 	Programmable
		Diagnostic functions	Programmable
		<ul style="list-style-type: none"> • Group error display • Diagnostic information readable 	Red LED (SF) Possible
		Substitute value can be applied	Yes, programmable

Data for Selecting an Actuator		Destruction limit against voltages/currents applied from outside	
Output ranges (rated values)			
• Voltage	±10 V 0 to 10 V 1 to 5 V	• Voltage at outputs to M _{ANA}	max. 15 V continuous 75 VDC for no more than 0.1 s (pulse duty factor 1 : 20)
• Current	±20 mA 0 to 20 mA 4 to 20 mA	• Current	max. 50 mA DC
Load resistance (in the nominal range of the output)		Connection of actuators	
• For voltage outputs	min. 1 kΩ	• For voltage output	
– Capacitive load	max. 1 μF	– Four-conductor connection (measuring circuit)	Possible
• For current outputs	max. 500 Ω	• For current output	
– Inductive load	max. 1 mH	– Two-conductor connection	Possible
Voltage outputs			
• Short-circuit protection	Yes		
• Short-circuit current	max. 40 mA		
Current outputs			
• No-load voltage	max. 18 V		

4.26.1 Commissioning the SM 332; AO 4 × 16 bits

Parameter

You will find a description of the general procedure for assigning parameters to analog modules in Section 4.7.

You will find an overview of the programmable parameters and their default values in Table 4-42, on page 4-47.

Assigning parameters to channels

You can configure each output channel of the SM 332; AO 4 × 16 bits individually. You can thus assign separate parameters for each output channel.

When you set the parameters with SFCs in the user program, the parameters are assigned to channel groups. Every output channel of the SM 332; AO 4 × 16 bits is assigned to a channel group in this instance – in other words, for example output channel 0 = channel group 0.

Note

If you modify output ranges when the analog output module SM 332; AO 4 × 16 bits is in operation, incorrect intermediate values may arise across the output.

Diagnostics

You will find the diagnostic messages that are grouped under the "group diagnosis" parameter in Table 4-47, on page 4-79.

4.26.2 Output Ranges of the Analog Output Module SM 332; AO 4 × 16 bits

Connecting the analog outputs

You can connect the outputs as voltage or current outputs, or disable them. You perform connection of the outputs with the "output type" parameter in *STEP 7*.

Unused channels

So that unused output channels of the SM 332; AO 4 × 16 bits remain de-energized, you must set the "output type" parameter to "disabled" and leave the terminal open.

Output ranges

You program the output ranges for voltage and current outputs in *STEP 7*.

Table 4-80 Output Ranges of the Analog Output Module SM 332; AO 4 × 16 bits

Selected Type of Output	Output Range	Description
Voltage	1 to 5 V 0 to 10 V ± 10 V	You will find the digital analog values in Section 4.3.2 in the voltage and current output ranges
Current	0 to 20 mA 4 to 20 mA ± 20 mA	

Default settings

The default settings of the module are "Voltage" for the output type and "± 10 V" for the output range. You can use this combination of output type and output range without parameterizing the SM 332; AO 4 × 16 bits in *STEP 7*.

Substitute values

You can configure the SM 332; AO 4 × 16 bits for the CPU operating mode STOP as follows: Outputs De-energized, Hold Last Value or Inject Substitute Values. If you inject substitute values, they must be within the output range.

4.27 Analog Output Module SM 332; AO 4 × 12 bits; (6ES7 332-5HD01-0AB0)

Order number

6ES7 332-5HD01-0AB0

Characteristics

The analog output module SM 332; AO 4 × 12 bits has the following characteristic features:

- 4 outputs in 4 channel groups
- The individual output channels can be programmed as
 - Voltage outputs
 - Current outputs
- Resolution 12 bits
- Programmable diagnostics
- Programmable diagnostic interrupt
- Programmable substitute value output
- Isolated against backplane bus interface and load voltage

**Terminal connection and block diagram of analog output module SM 332;
AO 4 × 12 bits**

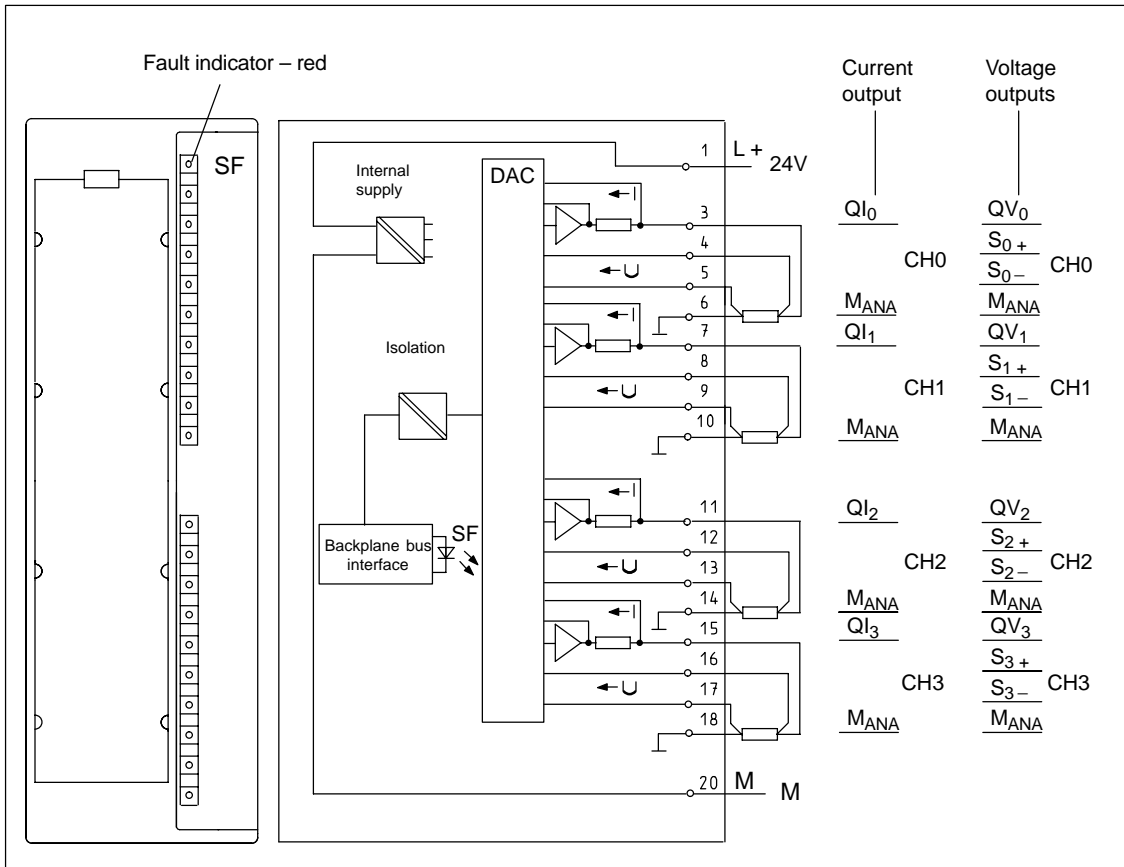

Figure 4-50 Module View and Block Diagram of the Analog Output Module SM 332; AO 4 × 12 bits

Technical specifications of the SM 332; AO 4 × 12 bits

Dimensions and Weight		Analog Value Generation	
Dimensions W × H × D (in millimeters)	40 × 125 × 117	Resolution including sign	
Weight	Approx. 220 g	<ul style="list-style-type: none"> ± 10 V; ± 20 mA; 11 bits + sign 4 to 20 mA; 1 to 5 V 	
Data for Specific Module		<ul style="list-style-type: none"> 0 to 10 V; 0 to 20 mA 	12 bits
Supports clocked operation	No	Conversion time (per channel)	max. 0.8 ms
Number of outputs	4	Settling time	
Length of cable		<ul style="list-style-type: none"> For resistive load 	0.2 ms
<ul style="list-style-type: none"> Shielded 	max. 200 m	<ul style="list-style-type: none"> For capacitive load 	3.3 ms
		<ul style="list-style-type: none"> For inductive load 	0.5 ms (1 mH) 3.3 ms (10 mH)
Voltages, Currents, Potentials		Suppression of Interference, Limits of Error	
Rated load voltage L +	24 VDC	Crosstalk between the outputs	> 40 dB
<ul style="list-style-type: none"> Reverse polarity protection 	Yes	Operational limit (in the entire temperature range, with reference to the output range)	
Isolation		<ul style="list-style-type: none"> Voltage outputs 	± 0.5 %
<ul style="list-style-type: none"> Between channels and backplane bus 	Yes	<ul style="list-style-type: none"> Current outputs 	± 0.6 %
<ul style="list-style-type: none"> Between channels and power supply of the electronics 	Yes	Basic error (operational limit at 25° C, referred to output range)	
<ul style="list-style-type: none"> Between the channels 	No	<ul style="list-style-type: none"> Voltage outputs 	± 0.4 %
<ul style="list-style-type: none"> Between channels and load voltage L+ 	Yes	<ul style="list-style-type: none"> Current outputs 	± 0.5 %
Permitted potential difference		Temperature error (with reference to the output range)	± 0.002 %/K
<ul style="list-style-type: none"> Between S– and M_{ANA} (U_{CM}) 	3 VDC	Linearity error (with reference to the output range)	± 0.05 %
<ul style="list-style-type: none"> Between M_{ANA} and M_{internal} (U_{ISO}) 	75 VDC / 60 VAC	Repeatability (in steady state at 25 °C, referred to output range)	± 0.05 %
Insulation tested with	500 VDC	Output ripple; range 0 to 50 kHz (referred to output range)	± 0.05 %
Current consumption		Status, Interrupts, Diagnostics	
<ul style="list-style-type: none"> From the backplane bus 	max. 60 mA	Interrupts	
<ul style="list-style-type: none"> From the load voltage L+ (no load) 	max. 240 mA	<ul style="list-style-type: none"> Diagnostic interrupt 	Parameters can be assigned
Power dissipation of the module	typ. 3 W	Diagnostic functions	Programmable
		<ul style="list-style-type: none"> Group error display 	Red LED (SF)
		<ul style="list-style-type: none"> Diagnostic information readable 	Possible
		Substitute value can be applied	Yes, programmable

Data for Selecting an Actuator		Destruction limit against voltages/currents applied from outside	
Output ranges (rated values)			
• Voltage	±10 V 0 to 10 V 1 to 5 V	• Voltage at outputs to M _{ANA}	max. 18 V continuous; 75 V for max. 1 s (duty factor 1:20)
• Current	±20 mA 0 to 20 mA 4 to 20 mA	• Current	max. 50 mA DC
Load resistance (in the nominal range of the output)		Connection of actuators	
• For voltage outputs	min. 1 kΩ	• For voltage output	
– Capacitive load	max. 1 μF	– Four-conductor connection (measuring circuit)	Possible
• For current outputs	max. 500 Ω	• For current output	
– At U _{CM} < 1V	max. 600 Ω	– Two-conductor connection	Possible
– Inductive load	max. 10 mH		
Voltage outputs			
• Short-circuit protection	Yes		
• Short-circuit current	max. 25 mA		
Current outputs			
• No-load voltage	max. 18 V		

4.27.1 Commissioning the SM 332; AO 4 × 12 bits

Note

When switching on and off the rated load voltage (L+), wrong intermediate values can occur across the output for approximately 10 ms.

Parameter

You will find a description of the general procedure for assigning parameters to analog modules in Section 4.7.

You will find an overview of the programmable parameters and their default values in Table 4-42, on page 4-47.

Assigning parameters to channels

You can configure each output channel of the SM 332; AO 4 × 12 bits individually. You can thus assign separate parameters for each output channel.

When you set the parameters with SFCs in the user program, the parameters are assigned to channel groups. Every output channel of the SM 332; AO 4 × 12 bits is assigned to a channel group in this instance – in other words, for example output channel 0 = channel group 0.

Note

If you modify output ranges when the analog output module SM 332; AO 4 × 12 bits is in operation, incorrect intermediate values may arise across the output.

Diagnostics

You will find the diagnostic messages that are grouped under the "group diagnosis" parameter in Table 4-47, on page 4-79.

4.27.2 Output Ranges of the Analog Output Module SM 332; AO 4 × 12 bits

Connecting the analog outputs

You can connect the outputs as voltage or current outputs, or disable them. You perform connection of the outputs with the "output type" parameter in *STEP 7*.

Unused channels

So that unused output channels of the SM 332; AO 4 × 12 bits remain de-energized, you must set the "output type" parameter to "disabled" and leave the terminal open.

Output ranges

You program the output ranges for voltage and current outputs in *STEP 7*.

Table 4-81 Output Ranges of the Analog Output Module SM 332; AO 4 × 12 bits

Selected Type of Output	Output Range	Description
Voltage	1 to 5 V 0 to 10 V ± 10 V	You will find the digital analog values in Section 4.3.2 in the voltage and current output ranges
Current	0 to 20 mA 4 to 20 mA ± 20 mA	

Default settings

The default settings of the module are "Voltage" for the output type and "± 10 V" for the output range. You can use this combination of output type and output range without parameterizing the SM 332; AO 4 × 12 bits in *STEP 7*.

Wire-break check

The analog output module SM 332; AO 4 × 12 bits carries out a wire-break check only for current outputs.

Short-circuit test

The analog output module SM 332; AO 4 × 12 bits carries out a short-circuit test only for voltage outputs.

Substitute values

You can configure the SM 332; AO 4 × 12 bits for the CPU operating mode STOP as follows: Outputs De-energized, Hold Last Value or Inject Substitute Values. If you inject substitute values, they must be within the output range.

Special characteristic of substitute values for output ranges 1 to 5 V and 4 to 20 mA

The following special characteristic applies to output ranges 1 to 5 V and 4 to 20 mA:

You have to set the substitute value $E500_H$ for the output to become de-energized (refer to Tables 4-35 and 4-37 on pages 4-29 and 4-30).

4.28 Analog Input/Output Module SM 332; AO 2 × 12 bits; (6ES7 332-5HBx1-0AB0)

Order number

6ES7 332-5HB01-0AB0

Order number: "SIMATIC Outdoor module"

6ES7 332-5HB81-0AB0

Characteristics

The analog output module SM 332; AO 2 × 12 bits has the following characteristic features:

- 2 output in 2 channels groups
- The individual output channels can be programmed as
 - Voltage outputs
 - Current outputs
- Resolution 12 bits
- Programmable diagnostics
- Programmable diagnostic interrupt
- Programmable substitute value output
- Isolated against backplane bus interface and load voltage

Terminal connection diagram and block diagram of the SM 332; AO 2 × 12 bits

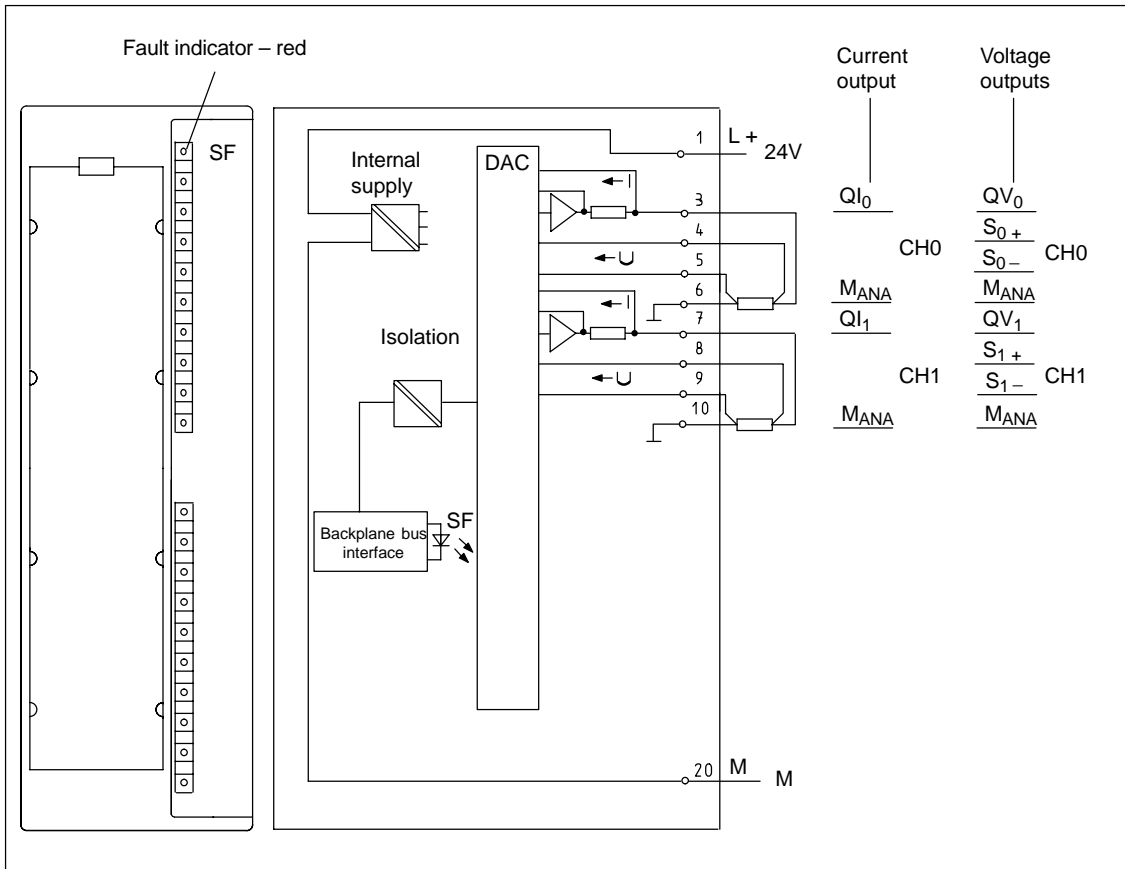

Figure 4-51 Module View and Block Diagram of the Analog Output Module SM 332; AO 2 × 12 bits

Technical specifications of the SM 332; AO 2 × 12 bits

Dimensions and Weight		Analog Value Generation	
Dimensions W × H × D (in millimeters)	40 × 125 × 117	Resolution including sign	
Weight	Approx. 220 g	<ul style="list-style-type: none"> ± 10 V; ± 20 mA; 11 bits + sign 4 to 20 mA; 1 to 5 V 	
Data for Specific Module		<ul style="list-style-type: none"> 0 to 10 V; 0 to 20 mA 	12 bits
Supports clocked operation	No	Conversion time (per channel)	max. 0.8 ms
Number of outputs	2	Settling time	
Length of cable		<ul style="list-style-type: none"> For resistive load 	0.2 ms
<ul style="list-style-type: none"> Shielded 	max. 200 m	<ul style="list-style-type: none"> For capacitive load 	3.3 ms
		<ul style="list-style-type: none"> For inductive load 	0.5 ms (1 mH) 3.3 ms (10 mH)
Voltages, Currents, Potentials		Suppression of Interference, Limits of Error	
Rated load voltage L +	24 VDC	Crosstalk between the outputs	> 40 dB
<ul style="list-style-type: none"> Reverse polarity protection 	Yes	Operational limit (in the entire temperature range, with reference to the output range)	
Isolation		<ul style="list-style-type: none"> Voltage outputs 	± 0.5 %
<ul style="list-style-type: none"> Between channels and backplane bus 	Yes	<ul style="list-style-type: none"> Current outputs 	± 0.6 %
<ul style="list-style-type: none"> Between channels and power supply of the electronics 	Yes	Basic error (operational limit at 25° C, referred to output range)	
<ul style="list-style-type: none"> Between the channels 	No	<ul style="list-style-type: none"> Voltage outputs 	± 0.4 %
<ul style="list-style-type: none"> Between channels and load voltage L+ 	Yes	<ul style="list-style-type: none"> Current outputs 	± 0.5 %
Permitted potential difference		Temperature error (with reference to the output range)	± 0.002 %/K
<ul style="list-style-type: none"> Between S– and M_{ANA} (U_{CM}) 	3 VDC	Linearity error (with reference to the output range)	± 0.05 %
<ul style="list-style-type: none"> Between M_{ANA} and M_{internal} (U_{ISO}) 	75 VDC / 60 VAC	Repeatability (in steady state at 25 °C, referred to output range)	± 0.05 %
Insulation tested with	500 VDC	Output ripple; range 0 to 50 kHz (referred to output range)	± 0.05 %
Current consumption		Status, Interrupts, Diagnostics	
<ul style="list-style-type: none"> From the backplane bus 	max. 60 mA	Interrupts	
<ul style="list-style-type: none"> From the load voltage L+ (no load) 	max. 135 mA	<ul style="list-style-type: none"> Diagnostic Interrupt 	Parameters can be assigned
Power dissipation of the module	typ. 3 W	Diagnostic functions	Programmable
		<ul style="list-style-type: none"> Group error display 	Red LED (SF)
		<ul style="list-style-type: none"> Diagnostic information readable 	Possible
		Substitute value can be applied	Yes, programmable

Data for Selecting an Actuator		Destruction limit against voltages/currents applied from outside	
Output ranges (rated values)			
• Voltage	±10 V 0 to 10 V 1 to 5 V	• Voltage at outputs to M _{ANA}	max. 18 V continuous; 75 V for max. 1 s (duty factor 1:20)
• Current	±20 mA 0 to 20 mA 4 to 20 mA	• Current	max. 50 mA DC
Load resistance (in the nominal range of the output)		Connection of actuators	
• For voltage outputs	min. 1 kΩ	• For voltage output	
– Capacitive load	max. 1 μF	– Two-conductor connection	Possible
• For current outputs	max. 500 Ω	– Four-conductor connection (measuring circuit)	Possible
– At U _{CM} < 1V	max. 600 Ω		
– Inductive load	max. 10 mH	• For current output	
Voltage outputs		– Two-conductor connection	Possible
• Short-circuit protection	Yes		
• Short-circuit current	max. 25 mA		
Current outputs			
• No-load voltage	max. 18 V		

4.28.1 Commissioning the SM 332; AO 2 × 12 bits

Note

When switching on and off the rated load voltage (L+), wrong intermediate values can occur across the output for approximately 10 ms.

Parameter

You will find a description of the general procedure for assigning parameters to analog modules in Section 4.7.

You will find an overview of the programmable parameters and their default values in Table 4-42, on page 4-47.

Assigning parameters to channels

You can configure each output channel of the SM 332; AO 2 × 12 bits individually. You can thus assign separate parameters for each output channel.

When you set the parameters with SFCs in the user program, the parameters are assigned to channel groups. Every output channel of the SM 332; AO 2 × 12 bits is assigned to a channel group in this instance – in other words, for example output channel 0 = channel group 0.

Note

If you modify output ranges when the analog output module SM 332; AO 2 × 12 bits is in operation, incorrect intermediate values can arise across the output.

Diagnostics

You will find the diagnostic messages that are grouped under the “group diagnosis” parameter in Table 4-47, on page 4-79.

4.28.2 Output Ranges of the Analog Output Module SM 332; AO 2 × 12 bits

Connecting the analog outputs

You can connect the outputs as voltage or current outputs, or disable them. You perform connection of the outputs with the “output type” parameter in *STEP 7*.

Unused channels

So that unused output channels of the SM 332; AO 2 × 12 bits remain de-energized, you must set the “output type” parameter to “disabled” and leave the terminal open.

Output ranges

You program the output ranges for voltage and current outputs in *STEP 7*.

Table 4-82 Output Ranges of the Analog Output Module SM 332; AO 2 × 12 bits

Selected Type of Output	Output Range	Description
Voltage	1 to 5 V 0 to 10 V ± 10 V	You will find the digital analog values in Section 4.3.2 in the voltage and current output ranges
Current	0 to 20 mA 4 to 20 mA ± 20 mA	

Default settings

The default settings of the module are "Voltage" for the output type and "± 10 V" for the output range. You can use this combination of output type and output range without parameterizing the SM 332; AO 2 × 12 bits in *STEP 7*.

Wire-break check

The analog output module SM 332; AO 2 × 12 bits carries out a wire-break check only for current outputs.

Short-circuit test

The analog output module SM 332; AO 2 × 12 bits carries out a short-circuit check only for voltage outputs.

Substitute values

You can configure the SM 332; AO 2 × 12 bits for the CPU operating mode STOP as follows: Outputs De-energized, Hold Last Value or Inject Substitute Values. If you inject substitute values, they must be within the output range.

Special characteristic of substitute values for output ranges 1 to 5 V and 4 to 20 mA

The following special characteristic applies to output ranges 1 to 5 V and 4 to 20 mA:

You have to set the substitute value $E500_H$ for the output to remain de-energized (refer to Tables 4-35 and 4-37 on pages 4-29 and 4-30).

4.29 Analog Input/Output Module SM334; AI 4/AO 2 × 8/8 bits; (6ES7 334-0CE01-0AA0)

Order number

6ES7 334-0CE01-0AA0

Characteristics

The analog input/output module SM 334: AI 4/AO 2 × 8/8 bits has the following characteristic features:

- Four inputs, two outputs
- Resolution 8 bits
- Not parameterizable, setting of measurement and output type by means of wiring
- Measuring range of 0 to 10 V or 0 to 20 mA
- Output range of 0 to 10 V or 0 to 20 mA
- Both voltage and current output options
- Non-isolated against the backplane bus interface
- Isolated from load voltage

Module view and block diagram of the SM 334; AI 4/AO 2 × 8/8 bits

Select the measuring method of the input channels and the output type of the output channels via the wiring.

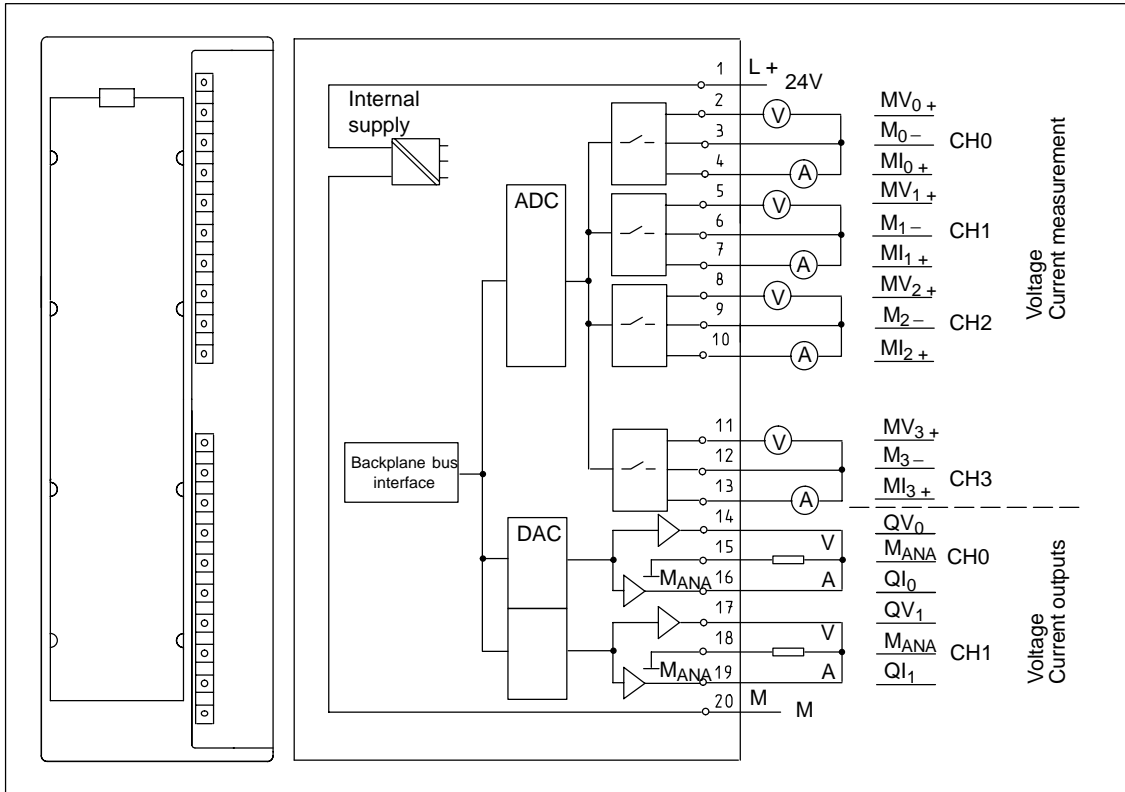

Figure 4-52 Module View and Block Diagram of the Analog Input/Output Module SM 334; AI 4/AO 2 × 8/8 bits

Technical specifications of the SM 334; AI 4/AO 2 × 8/8 bits

Dimensions and Weight	
Dimensions W × H × D (in millimeters)	40 × 125 × 117
Weight	Approx. 285 g
Data for Specific Module	
Supports clocked operation	No
Number of inputs	4
Number of outputs	2
Length of cable	
• Shielded	max. 200 m
Voltages, Currents, Potentials	
Rated load voltage L +	24 VDC
Power rated voltage of the rated electronics voltage and rated load voltage L+	24 VDC
Isolation	
• Between channels and backplane bus	No
• Between channels and power supply of the electronics	Yes
Between the channels	No
Permitted potential difference	
• Between inputs and M _{ANA} (U _{CM})	1 VDC
• Between the inputs (ECM)	1 VDC
Insulation tested with	500 VDC
Current consumption	
• From the backplane bus	max. 55 mA
• From power supply and load voltage L+ (no load)	max. 110 mA
Power dissipation of the module	typ. 3 W
Analog Value Generation for the Inputs	
Measuring principle	Instantaneous value conversion
Integration/conversion time (per channel)	
• Parameters can be assigned	No
• Integration time in milliseconds	500

• Basic conversion time including Integration time in milliseconds	100
• Resolution including sign	8 bits
Time constant of the input filter	max. 0.8 ms
Basic execution time of the module (all channels enabled)	max. 5 ms
Analog Value Generation for the Outputs	
Resolution including sign	8 bits
Conversion time (per channel)	max. 500 μs
Settling time	
• For resistive load	0.3 ms
• For capacitive load	3.0 ms
• For inductive load	0.3 ms
Suppression of Interference, Limits of Error for the Inputs	
Noise suppression for $f = n \times (f_1 \pm 1 \%)$ ($f_1 =$ interference frequency)	
• Common-mode interference (U _{pp} < 1 V)	> 60 dB
Crosstalk between the outputs	> 50 dB
Operational limit (in the entire temperature range, with reference to the input range)	
• Voltage input	± 0.9 %
• Current input	± 0.8 %
Basic error (operational limit at 25° C, referred to input range)	
• Voltage input	± 0.7 %
• Current input	± 0.6 %
Temperature error (with reference to the input range)	± 0.005 %/K
Linearity error (with reference to the input range)	± 0.05 %
Repeatability (in steady state at 25 °C referred to input range)	± 0.05 %
Output ripple; range 0 to 50 kHz (referred to output range)	± 0.05 %

Suppression of Interference, Limits of Error	Data for Selecting an Actuator						
Crosstalk between the outputs > 40 dB Operational limit (in the entire temperature range, with reference to the output range) <ul style="list-style-type: none"> • Voltage outputs ± 0.6 % • Current outputs ± 1.0 % Basic error (operational limit at 25 °C referred to the output range) <ul style="list-style-type: none"> • Voltage outputs ± 0.5 % • Current outputs ± 0.5 % Temperature error (with reference to the output range) ± 0.02 %/K Linearity error (with reference to the output range) ± 0.05 % Repeat accuracy (in the steady state at 25 °C referred to the output range) ± 0.05 % Output ripple (bandwidth referred to the output range) ± 0.05 %	Output ranges (rated values) <ul style="list-style-type: none"> • Voltage 0 to 10 V • Current 0 to 20 mA Impedance (in the nominal output range) <ul style="list-style-type: none"> • For voltage outputs min. 5 kΩ <ul style="list-style-type: none"> – Capacitive load max. 1 μF • For current outputs max. 300 Ω <ul style="list-style-type: none"> – Inductive load max. 1 mH Voltage outputs <ul style="list-style-type: none"> • Short-circuit protection Yes • Short-circuit current max. 11 mA Current outputs <ul style="list-style-type: none"> • No-load voltage max. 15 V Destruction limit against voltages/currents applied from outside <ul style="list-style-type: none"> • Voltage at outputs to M_{ANA} max. 15 V continuous; • Current max. 50 mA DC Connection of actuators <ul style="list-style-type: none"> • For voltage output <table style="margin-left: 20px; border: none;"> <tr> <td>Two-conductor connection</td> <td>Possible</td> </tr> <tr> <td>Four-conductor connection (measuring circuit)</td> <td>Not possible</td> </tr> </table> Connection of the sensor <ul style="list-style-type: none"> • For measuring current <table style="margin-left: 20px; border: none;"> <tr> <td>Two-conductor connection</td> <td>Possible</td> </tr> </table> 	Two-conductor connection	Possible	Four-conductor connection (measuring circuit)	Not possible	Two-conductor connection	Possible
Two-conductor connection	Possible						
Four-conductor connection (measuring circuit)	Not possible						
Two-conductor connection	Possible						
Status, Interrupts, Diagnostics							
Interrupts None							
Diagnostic functions None							
Data for Selecting a Sensor							
Input range (rated values)/Input resistance <ul style="list-style-type: none"> • Voltage 0 to 10 V/100 k Ω • Current 0 to 20 mA/50 Ω Maximum input voltage for voltage input (destruction limit) max. 20 V continuous; 75 V for max. 1 s (duty factor 1:20) Maximum input current for current input (destruction limit) 40 mA Connection of the sensor <ul style="list-style-type: none"> • For measuring voltage Possible • For measuring current <table style="margin-left: 20px; border: none;"> <tr> <td>As two-wire transmitter</td> <td>Not possible</td> </tr> <tr> <td>As four-wire transmitter</td> <td>Possible</td> </tr> </table> 	As two-wire transmitter	Not possible	As four-wire transmitter	Possible			
As two-wire transmitter	Not possible						
As four-wire transmitter	Possible						

4.29.1 Commissioning the SM 334; AI 4/AO 2 × 8/8 bits

The analog/output module SM 334; AI 4/AO 2 x 8/8 bits is a non-isolated module. You cannot program the SM 334; AI 4/AO 2 × 8/8 bits.

Important information on connecting the module

Note

Note when connecting the SM 334 that:

- the **analog chassis ground M_{ANA} (terminal 15 or 18) is connected to the chassis ground M of the CPU and/or the interface module (IM)**. Use a wire with a minimum cross-section of 1 mm² for this.

If there is no ground connection between M_{ANA} and M, the module switches off. Inputs are read with 7FFF_H; outputs return a value of 0. If the module is run without a ground connection for some time, it may be destroyed.

- the **supply voltage for the CPU and/or the interface module (IM) must not be connected with reversed polarity**. Reverse polarity causes the destruction of the module because M_{ANA} is subjected to an unauthorized high potential (+24 V).

Addressing

The inputs and outputs of the module are addressed as of the initial module address.

The address of a channel is obtained from the module start address and an address offset.

Input addresses

The following addresses apply to the inputs:

Chan- nel	Address
0	Initial module address
1	Module start address + 2 bytes address offset
2	Module start address + 4 bytes address offset
3	Module start address + 6 bytes address offset

Output addresses

The following channel addresses apply to the module outputs:

Chan- nel	Address
0	Initial module address
1	Module start address + 2 bytes address offset

4.29.2 Measuring/Output Method and Measuring/Output Range of the SM 334; AI 4/AO 2 × 8/8 bits

You cannot program the SM 334; AI 4/AO 2 × 8/8 bits.

Selecting the measurement method and the type of output

Select the measuring method of an input channel (voltage, current) by wiring the input channel appropriately.

Select the type of output of an output channel (voltage, current) by wiring the output channel appropriately.

Unused channels

You must short-circuit unused input channels and you should connect them to M_{ANA} . In this way, you obtain an optimum noise immunity for the analog module.

Unused output channels must be left open.

Measuring ranges

The SM 334; AI 4/AO 2 × 8/8 bits has the measuring ranges 0 to 10 V and 0 to 20 mA.

Unlike the other analog modules, the SM 334 has a lower resolution and no negative measuring ranges. Take this into account when you read measured value tables 4-10 and 4-14 on pages 4-14 and 4-16.

Output ranges

The SM 334; AI 4/AO 2 × 8/8 bits has the output ranges 0 to 10 V and 0 to 20 mA.

Unlike the other analog modules, the SM 334 has a lower resolution the analog outputs do not have underranges. Take this into account when you read tables 4-35 and 4-37 on pages 4-29 and 4-30.

4.30 Analog Input/Output Module SM 334; AI 4/AO 2 × 12 bits; (6ES7 334-0KE00-0AB0)

Order number

6ES7 334-0KE00-0AB0

Characteristics

The SM 334 has the following characteristic features:

- Four inputs in two groups
- 2 outputs (voltage outputs)
- Resolution of 12 bits + sign
- Measuring method selectable
 - Voltage
 - Resistors
 - Temperature
- Isolated against the backplane bus interface
- Isolated from load voltage

Terminal connection and block diagram of the SM334; AI 4/AO 2 × 12 bits

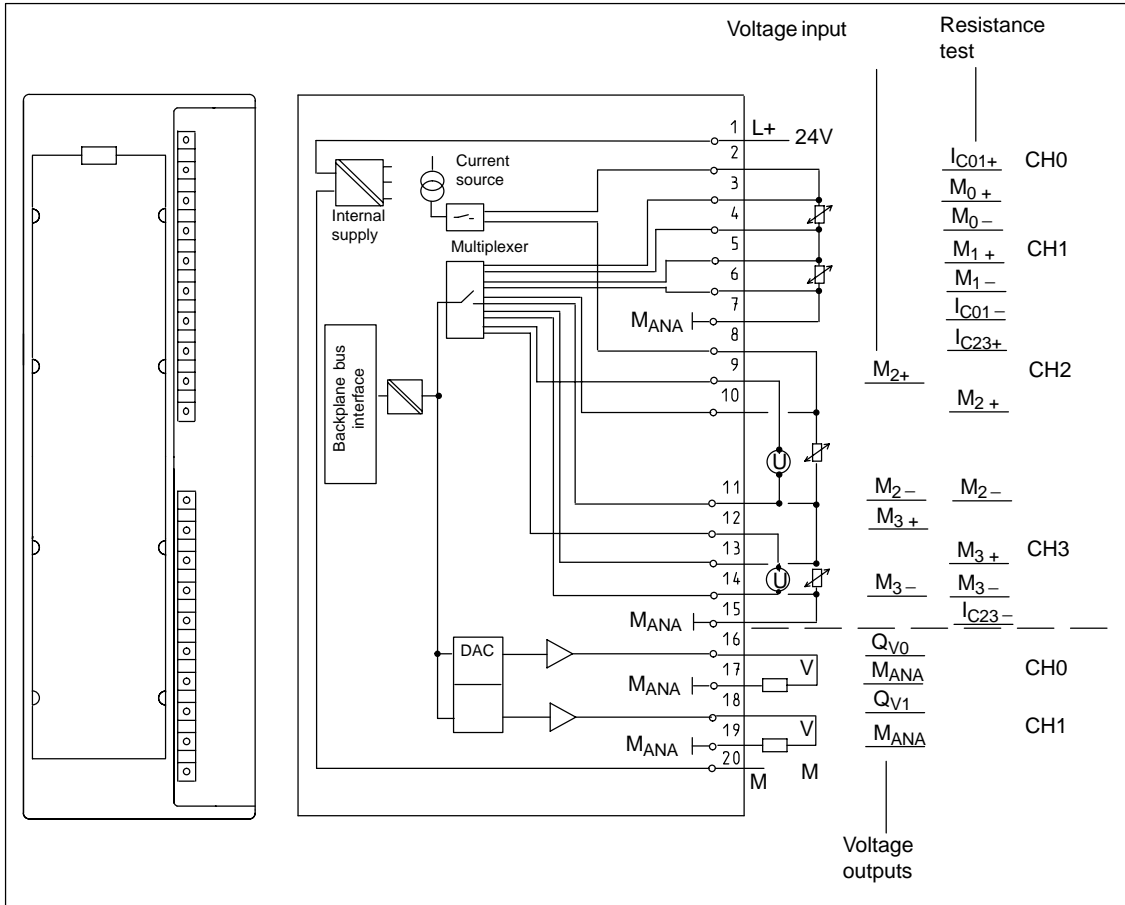

Figure 4-53 Module View and Block Diagram of the SM 334; AI 4/AO 2 × 12 bits

Technical specifications of the SM334; AI 4/AO 2 × 12 bits

Dimensions and Weight		Analog Value Generation for the Inputs		
Dimensions W × H × D (in millimeters)	40 × 125 × 117	Measuring principle	Integrating	
Weight	Approx. 200 g	Integration/conversion time (per channel)		
Data for Specific Module		<ul style="list-style-type: none"> Parameters can be assigned 	Yes	
Supports clocked operation	No	<ul style="list-style-type: none"> Integration time in milliseconds 	$16^{2/3}$	20
Number of inputs	4	<ul style="list-style-type: none"> Basic conversion time including Integration time in milliseconds 	72	85
<ul style="list-style-type: none"> For resistance-type sensor 	4	<ul style="list-style-type: none"> Additional conversion time for measuring resistance, in ms 	72	85
Number of outputs	2	<ul style="list-style-type: none"> Resolution in bits (incl. overrange) 	12 bits	12 bits
Shielded line length	max. 100 m	<ul style="list-style-type: none"> Suppression of interference voltage for interference frequency f1 in Hertz 	60	50
Voltages, Currents, Potentials		Smoothing of the measured values	Programmable, in 2 stages	
Rated load voltage L +	24 VDC	Time constant of the input filter	0.9 ms	
<ul style="list-style-type: none"> Reverse polarity protection 	Yes	Basic response time of module (all channels enabled)	350 ms	
Supply voltage of the rated electronics voltage and rated load voltage L+	24 VDC	Analog Value Generation for the Outputs		
Power supply of the transmitters		Resolution (incl. Overrange)	12 bits	
<ul style="list-style-type: none"> Short-circuit-proof 	Yes	Conversion time (per channel)	500 μs	
Constant measured current for resistance-type sensor		Settling time		
<ul style="list-style-type: none"> For PT 100 	typ. 490 μA	<ul style="list-style-type: none"> For resistive load 	max. 0.8 ms	
<ul style="list-style-type: none"> At 10 kΩ 	at 105 μA	<ul style="list-style-type: none"> For capacitive load 	max. 0.8 ms	
Isolation				
<ul style="list-style-type: none"> Between channels and backplane bus 	Yes			
<ul style="list-style-type: none"> Between channels and power supply of the electronics 	Yes			
Between the channels	No			
Permitted potential difference				
<ul style="list-style-type: none"> Between inputs and M_{ANA} (U_{CM}) 	1 V			
<ul style="list-style-type: none"> Between the inputs (ECM) 	1 V			
<ul style="list-style-type: none"> Between M_{ANA} and M_{internal}(U_{ISO}) 	75 VDC / 60 VAC			
Insulation tested with	500 VDC			
Current consumption				
<ul style="list-style-type: none"> From the backplane bus 	max. 60 mA			
<ul style="list-style-type: none"> From power supply and load voltage L+ (no load) 	max. 80 mA			
Power dissipation of the module	typ. 2 W			

Suppression of Interference, Limits of Error for the Inputs	Status, Interrupts, Diagnostics	
<p>Noise suppression for $f = n \times (f1 \pm 1 \%)$ ($f1 =$ interference frequency)</p> <ul style="list-style-type: none"> Common-mode interference ($U_{pp} < 1 \text{ V}$) > 38 dB Series-mode interference (peak value of interference < rated value of input range) > 36 dB <p>Crosstalk between the inputs > 88 dB</p> <p>Operational limit (in the entire temperature range, with reference to the input range)</p> <ul style="list-style-type: none"> Voltage input 0 to 10 V $\pm 0.7 \%$ Resistor input 10 k Ω $\pm 3.5 \%$ Temperature input Pt 100 $\pm 1 \%$ <p>Basic error (operational limit at 25 °C, referred to input range)</p> <ul style="list-style-type: none"> Voltage input 0 to 10 V $\pm 0.5 \%$ Resistor input 10 k Ω $\pm 2.8 \%$ Temperature input Pt 100 $\pm 0.8 \%$ <p>Temperature error (with reference to the input range) $\pm 0.01 \%/K$</p> <p>Linearity error (with reference to the input range) $\pm 0.05 \%$</p> <p>Repeat accuracy (in the steady state at 25 °C, referred to the input range) $\pm 0.05 \%$</p>	<p>Interrupts None</p> <p>Diagnostic functions None</p>	
Suppression of interference, Limits of Error for the Outputs	Data for Selecting a Sensor	
<p>Crosstalk between the outputs > 88 dB</p> <p>Operational limit (in the entire temperature range, with reference to the output range)</p> <ul style="list-style-type: none"> Voltage outputs $\pm 1.0 \%$ <p>Basic error (operational limit at 25 °C, referred to output range)</p> <ul style="list-style-type: none"> Voltage outputs $\pm 0.85 \%$ <p>Temperature error (with reference to the output range) $\pm 0.01 \%/K$</p> <p>Linearity error (with reference to the output range) $\pm 0.01 \%$</p> <p>Repeat accuracy (in the steady state at 25°C, referred to the output range) $\pm 0.01 \%$</p> <p>Output ripple; band width 0 to 50 kHz (with reference to the output range) $\pm 0.1 \%$</p>	<p>Input range (rated values)/Input resistance</p> <ul style="list-style-type: none"> Voltage 0 to 10 V 100 k Ω Resistors 10 k Ω 10 m Ω Temperature PT 100 10 m Ω <p>Maximum input voltage for voltage input (destruction limit) max. 20 V continuous; 75 V for max. 1 s (duty factor 1:20)</p> <p>Connection of the sensor</p> <ul style="list-style-type: none"> For measuring voltage Possible For measuring resistance <ul style="list-style-type: none"> With two-conductor connection Possible With three-conductor connection Possible With four-conductor connection Possible <p>Characteristic linearization Parameters can be assigned</p> <ul style="list-style-type: none"> For RTD PT 100 (climate range) <p>User data in engineering format Degrees Celsius</p>	
	Data for Selecting an Actuator	
	<p>Output range (rated value)</p> <ul style="list-style-type: none"> Voltage 0 to 10 V <p>Impedance (in the nominal output range)</p> <ul style="list-style-type: none"> For voltage outputs <ul style="list-style-type: none"> min. 2.5 k Ω – Capacitive load max. 1.0 μF <p>Voltage outputs</p> <ul style="list-style-type: none"> Short-circuit protection Yes Short-circuit current max. 10 mA <p>Destruction limit for voltages/ currents connected from outside</p> <ul style="list-style-type: none"> Voltage at outputs to M_{ANA} max. 15 V continuous; <p>Connection of actuators</p> <ul style="list-style-type: none"> For voltage output <ul style="list-style-type: none"> Two-Conductor Connection Possible Four-conductor connection (measuring circuit) Not possible 	

4.30.1 Commissioning the SM 334; AI 4/AO 2 × 12 bits

Note

Below the rated load voltage range, incorrect intermediate values occur at the output when the rated load voltage supply (L+) is switched on/off.

STEP 7 V 4.0 tool for parameter assignment

The SM 334; AI 4/AO 2 × 12 bits is contained in the module catalog in *STEP 7 V* 4.0 or higher.

Parameter

You will find a description of the general procedure for assigning parameters to analog modules in Section 4.7.

You will find an overview of the programmable parameters and their default values in Table 4-43, on page 4-48.

4.30.2 Measuring/Output Method and Measuring/Output Range of the SM 334; AI 4/AO 2 × 12 bits

Connecting the inputs and outputs

You can connect the inputs as voltage, resistance or temperature measurement inputs, or deactivate them.

You can connect the outputs as voltage, or disable them.

Perform connection of the inputs and outputs with the parameters "measuring method" and "output method" in *STEP 7*.

Connection options for the input channels

You can connect the SM 334; AI 4/AO 2 × 12 bits in the following combinations:

Channel	Wiring Versions
Channels 0 and 1	<ul style="list-style-type: none"> • 2 x temperature or • 2 x resistance
Channels 2 and 3	<ul style="list-style-type: none"> • 2 x voltage, • 2 x resistance, • 2 x temperature, • 1 x temperature and 1 x voltage, or • 1 x resistance and 1 x voltage

Note

Simultaneous connection of a temperature sensor and a resistor to channels 0 and 1 and 2 and 3 is not allowed.

The reason common current source for both channels.

Unused channels

Set the "measuring method" parameter for unused input channels to "disabled". In this way you shorten the scan time of the module.

You must short-circuit unused input channels and you should connect them to M_{ANA} . In this way, you obtain an optimum interference immunity for the analog input module.

So that unused output channels of the SM 334; AI 4/AO 2×12 bits remain de-energized, you must set the "output type" parameter to "disabled" and leave the terminal open.

Measuring ranges

Use *STEP 7* for programming the measuring ranges.

Table 4-83 Measuring ranges of the SM 334; AI 4/AO 2×12 bits

Method Selected	Measuring Range	Description
U: Voltage	0 to 10 V	You will find the digital analog values in Section 4.3.1
R-4L: Resistance (four-conductor connection)	10 k Ω	
RTD-4L: Bulb resistor (linear, four-conductor connection) (temperature measurement)	Pt 100 climate	

Default settings of inputs

The default settings of the module are the "Bulb resistor (linear, four-conductor connection)" measuring method and the "Pt 100 climate" measuring range. You can use this combination of measuring method and measuring range without parameterizing the SM 334; AI 4/AO 2 × 12 bits in *STEP 7*.

Output ranges

Use *STEP 7* for programming the output ranges.

Table 4-84 Output Ranges of the SM 334;AI 4/AO 2 × 12 bits

Selected Type of Output	Output Range	Description
Voltage	0 to 10 V	You will find the digital analog values in Section 4.3.2 in the voltage output range

Default settings of outputs

The default settings of the module are "Voltage" for the output type and "0 to 10 V" for the output range. You can use this combination of measuring method and measuring range without parameterizing the SM 334; AI4/AO 2 × 2 bits in *STEP 7*.

5

Other Signal Modules

Changes and improvements since the previous version of the reference manual

A new overview section will make it easier for you to access the information:

- The “Module Overview” section shows you the modules that are available, together with their most important characteristics, and helps you quickly to find the module suitable for your task.

In this Chapter

Section	Contents	Page
5.1	Module Overview	5-2
5.2	Simulator Module SM 374; IN/OUT 16; (6ES7 374-2XH01-0AA0)	5-3
5.3	Dummy Module DM 370; (6ES7 370-0AA01-0AA0)	5-5
5.4	Position Detection Module SM 338; POS-INPUT; (6ES7 338-4BC01-0AB0)	5-7

5.1 Module Overview

Introduction

The following table summarizes the most important characteristics of the signal modules described in this chapter. This overview is intended to make it easy to choose the suitable module for your task.

Table 5-1 Other Signal Modules Characteristics at a Glance

Module Characteristics	Simulator Module SM 374; IN/OUT 16	Dummy Module DM 370	Position Detection Module SM 338; POS-INPUT
Number of inputs/outputs	<ul style="list-style-type: none"> Up to 16 inputs or outputs 	Reserves one slot for one non-programmed module	<ul style="list-style-type: none"> 3 inputs for connection of encoders absolute (SSI) 2 digital inputs for freezing encoder values
Suitable for...	Simulation of: <ul style="list-style-type: none"> 16 inputs or 16 outputs or 8 input and 8 outputs 	Dummy for: <ul style="list-style-type: none"> Interface Modules Non-programmed signal modules Modules occupying two slots 	Position detection with up to 3 encoders absolute (SSI) Encoder types: Encoder absolute (SSI) with 13 bit, 21 bit or 25 bit message frame length Data formats: Gray code or binary code
Programmable diagnostics	No	No	No
Diagnostic Interrupt	No	No	Adjustable
Special Features	The function can be set using screwdriver	When replacing the DM 370 with another module, the mechanical configuration and the address assignment of the overall configuration remain unchanged	Encoders absolute with a monoflop time of more than 64 μ s must not be used on the SM 338

5.2 Simulator Module SM 374; IN/OUT 16; (6ES7 374-2XH01-0AA0)

Order number

6ES7 374-2XH01-0AA0

Characteristics

The simulator module SM 374; IN/OUT 16 has the following salient features:

- Simulation of:
 - 16 inputs or
 - 16 outputs or
 - 8 inputs and 8 outputs (with the same start addresses each!)
- Status displays for simulation of inputs and outputs
- The function can be set using screwdriver

Note

Do not actuate the switch for setting the mode when the CPU is in the RUN mode!

Configuration with *STEP 7*

Simulator module SM 374; IN/OUT 16 is not included in the module catalog of *STEP 7*. In other words, the Order Number of SM 374 is not detected by *STEP 7*. You must therefore "simulate" the desired function of the simulator module for configuration in the following manner:

- If you want to use the SM 374 **with 16 inputs**, enter the Order Number of a digital input module with 16 inputs in *STEP 7*;
Example: 6ES7 321-1BH02-0AA0
- If you want to use the SM 374 **with 16 outputs**, enter the Order Number of a digital input module with 16 outputs in *STEP 7*;
Example: 6ES7 322-1BH01-0AA0
- If you want to use SM 374 **with 8 inputs and 8 outputs**, enter the Order Number of a digital input/output module with 8 inputs and 8 outputs in *STEP 7*;
Example: 6ES7 323-1BH00-0AA0

Module view (without front door)

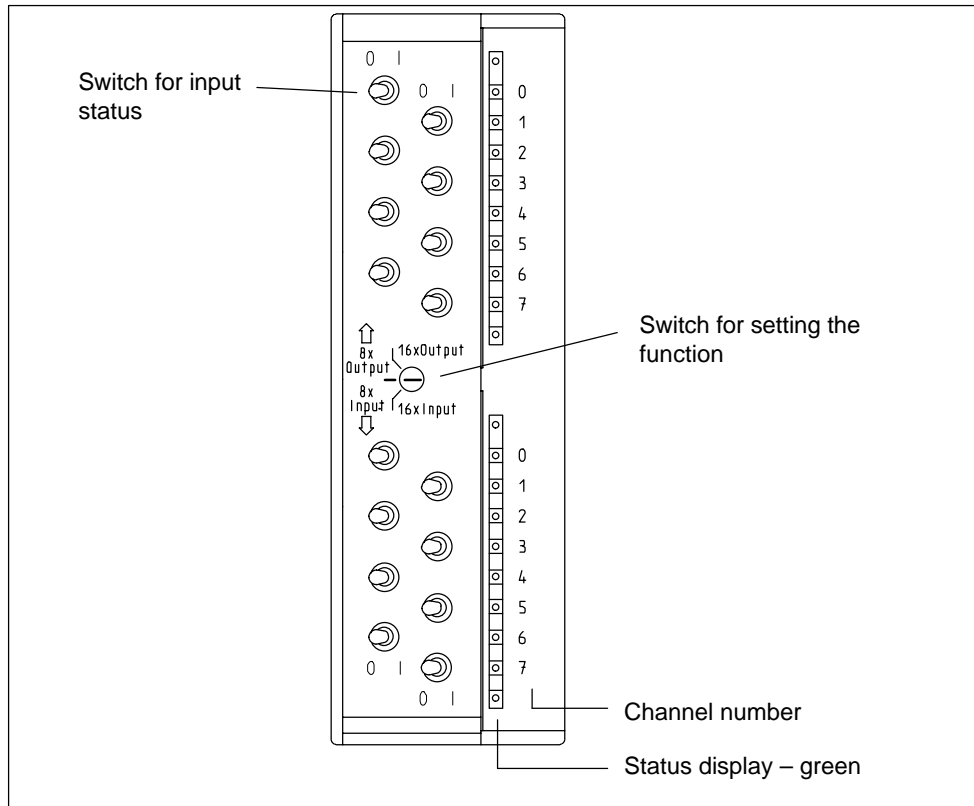

Figure 5-1 Module View of Simulator Module SM 374; IN/OUT 16

Technical specifications of the SM 374; IN/OUT 16

Dimensions and Weight		Voltages, Currents, Potentials	
Dimensions W × H × D (in millimeters)	40 × 125 × 110	Current consumption from the backplane bus	max. 80 mA
Weight	Approx. 190 g	Power dissipation of the module	typ. 0.35 W
Data for Specific Module		Status, Interrupts, Diagnostics	
Simulation either of	16 inputs 16 outputs 8 input and outputs	Status display	Yes, green LED per channel
		Interrupts	No
		Dagnostic functions	No

5.3 Dummy Module DM 370; (6ES7 370-0AA01-0AA0)

Order number

6ES7 370-0AA01-0AA0

Characteristics

Dummy module DM 370 reserves a slot for an unprogrammed module. It can be a dummy for:

- Interface modules (without reserving address space)
- Unprogrammed signal modules (with reservation address area)
- Modules occupying 2 slots (with reservation of address area)

When replacing the dummy module with another module from the S7-300, the mechanical configuration and the address assignment remain unchanged.

Configuration with *STEP 7*

Use *STEP 7* to configure the dummy module only if you are using the module to reserve the slot for a parameterized signal module. If the module is reserving the slot for an interface module, there is no need to configure with *STEP 7*.

Modules occupying two slots

For modules that occupy two slots, you must plug in two dummy modules. In doing so, you reserve the address area only with the dummy module at slot "x" (not with the dummy module at "x + 1"; for the steps you need to perform refer to Table 5-2).

Not more than 8 modules must be inserted in a mounting rack (SM/FM/CP). If, for example, you reserve one slot for an 80 mm module with two dummy modules, you may only insert seven more modules (SM/FM/CP) since the dummy module only occupies the address area for one module.

Module view

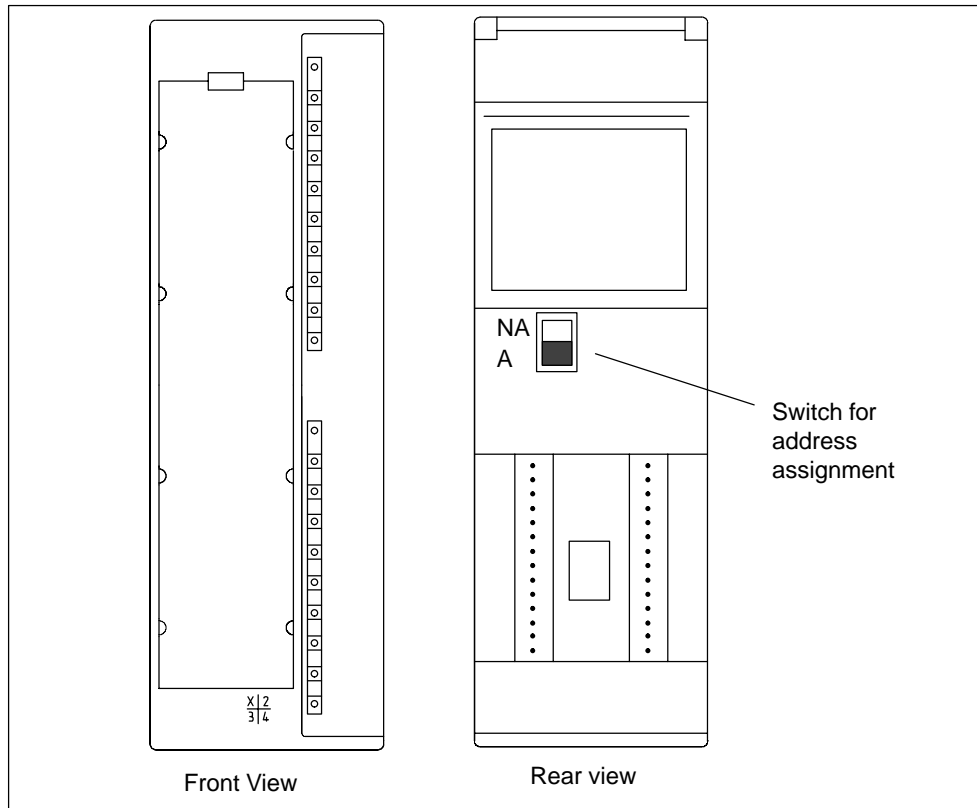
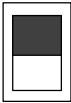
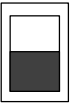

Figure 5-2 Module View of Dummy Module DM 370

Switch settings for address assignment

The table below shows how you have to set the switch on the back of the module to match the module type.

Table 5-2 Meaning of the Switch Positions of the Dummy Module DM 370

Switch Position	Meaning	Use in an ET 200M configuration with active bus modules (Insert and Remove)
NA  A	Dummy module reserves the slot for an interface module (NA = No Address, that is no address space reserved)	No
NA  A	Dummy module reserves the slot for a signal module (A = Address, that is address space reserved)	Dummy module reserves the slot for a signal module. If you use the dummy module for an “empty slot”, you must configure the “empty slot” with 0 bytes input/output addresses.

Technical specifications of the DM 370

Dimensions and Weight		Voltages, Currents, Potentials	
Dimensions W × H × D (in millimeters)	40 × 125 × 120	Current consumption from the backplane bus	Approx. 5 mA
Weight	Approx. 180 g	Power loss	typ. 0.03 W

5.4 Position Detection Module SM 338; POS-INPUT; (6ES7 338-4BC01-0AB0)

Order Number

6ES7 338-4BC01-0AB0

Characteristics

Position detection module SM 338; POS-INPUT features the following characteristics:

- 3 inputs for the connection of up to three encoders absolute (SSI) and 2 digital inputs for freezing encoder values
- Direct reaction to encoder values in moving systems possible
- Processing of the encoder values acquired by the SM 338 in the user program
- Isochrone mode
- You can select the following types of encoder value detection (Section 5.4.4):
 - Free-running
 - Isochrone
- 24 VDC rated input voltage
- Isolated from CPU

Supported encoder types

The following encoder types are supported by the SM 338; POS-INPUT :

- The encoder absolute (SSI) with 13 bit message frame length
- The encoder absolute (SSI) with 21 bit message frame length
- The encoder absolute (SSI) with 25 bit message frame length

Supported data formats

The SM 338; POS-INPUT supports the gray code and binary code data formats.

5.4.1 Isochrone Mode

Note

The principles of isochrone mode are described in a separate manual.

Hardware

You will require the following for isochrone mode of the SM 338:

- A CPU that supports isochrone mode
- A DP master that supports the equidistant bus cycle
- Slave interface module (IM 153-x) that supports isochrone mode

Features

Depending on the system parameter assignment, the SM 338 works in either non-isochrone or isochrone mode.

In isochrone mode, the transmission of data between the DP master and SM 338 is isochrone to the PROFIBUS DP cycle.

In isochrone mode the 16 bytes of the feedback interface are consistent.

If clocking is lost due to faults or failure or a delay in global control (GC), the SM 338 will return to isochrone mode at the next cycle without an error response.

If clocking is lost, the feedback interface is not updated.

5.4.2 Terminal connection diagram and block diagram

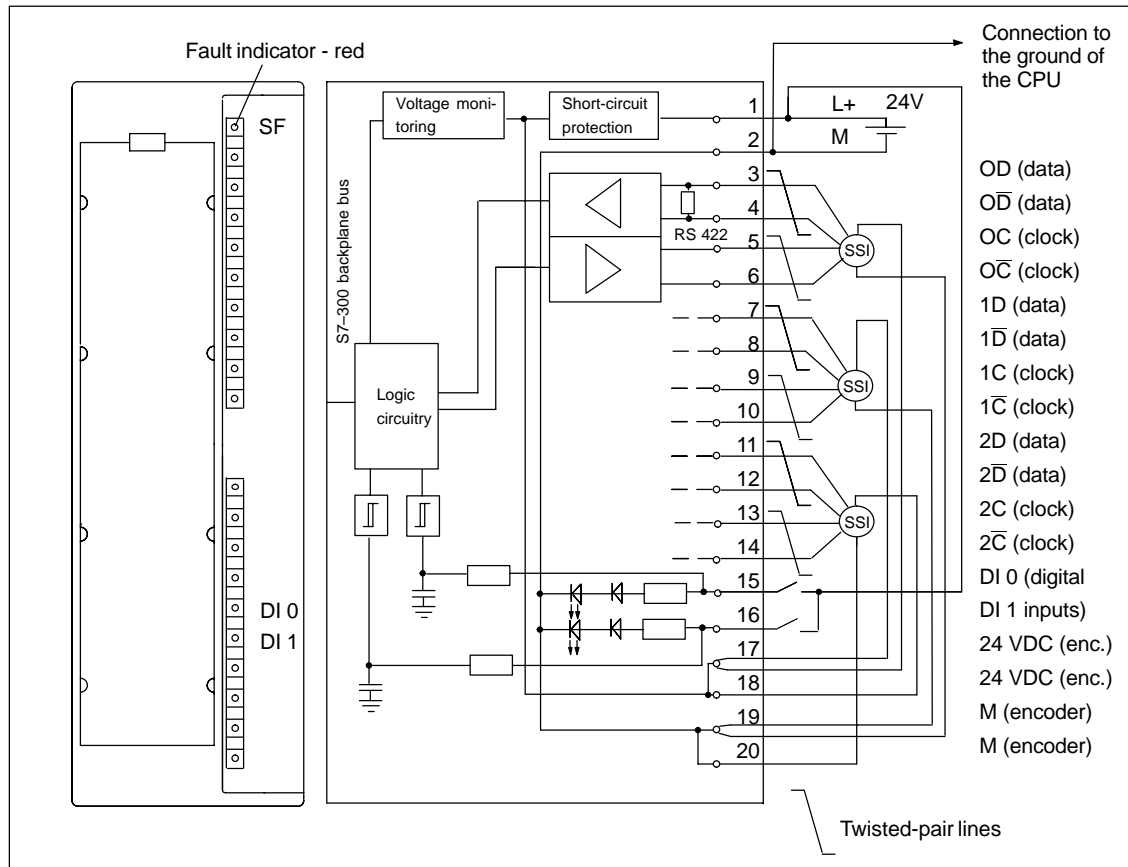

Figure 5-3 Module View and Block Diagram of the SM 338; POS-INPUT

Wiring Rules

Be sure to observe the following important rules when wiring the module:

- The ground of the encoder supply is non-isolated to the ground of the CPU. Therefore connect pin 2 of the SM 338 (M) to the ground of the CPU with low impedance.
- The encoder lines (pins 3 to 14) must be shielded, twisted-pair cables. Support the shield on either side. To support the shield on the SM 338, use the shield supporting element (Order number: 6ES7 390-5AA00-0AA0).
- If you exceed the maximum output current (900 mA) of the encoder supply, you must connect an external power supply.

5.4.3 Functions of the SM 338; POS-INPUT

5.4.4 Encoder Value Detection

The absolute encoder transfers its encoder values in message frames to the SM 338. The transmission of message frames is initiated by the SM 338.

- in non-isochrone mode the encoder value detection will run freely.
- in isochrone mode the encoder value detection will occur synchronously to the PROFIBUS DP cycle at the time T_i .

Free-Running Encoder Value Detection

The SM 338 initiates the transmission of a message frame each time the parameterized monoflop time elapses.

The SM 338 processes the detected encoder value asynchronously to these free-running message frames in the cycle of the update rate (see the technical specifications).

Because of this, some old encoder values result with the free-running detection of encoder values. The difference between the maximum and minimum age is the jitter (see the Technical Specifications).

Isochrone Encoder Value Detection

Isochrone encoder value detection is carried out automatically when the equidistant bus cycle is activated in the DP master system and the DP slave is synchronized to the DP cycle.

The SM 338 initiates the transmission of a message frame in each PROFIBUS DP cycle at the time T_i .

The SM 338 processes the transmitted encoder value at a clocked rate to the PROFIBUS DP cycle.

5.4.5 Gray / Binary Converter

When gray is set, the encoder value supplied by the absolute encoder in gray code is converted to binary code. When binary is set, the encoder value that is delivered is not converted.

Note

If you selected the setting Gray, the SM 338 always converts the total encoder value (13, 21, 25 bits). Preceding special bits thus influence the encoder value and trailing bits can under some circumstances be corrupted.

5.4.6 Transmitted Encoder Value and Normalizing

The transmitted encoder value contains the encoder position of the absolute value encoder. Depending on the encoder that is used, other bits that are located before and after the encoder position are transmitted in addition to the encoder position.

So that the SM 338 can determine the encoder position, specify the following:

- Normalizing, Positions (0..12),
- Normalizing, Steps / revolution

Normalizing, Positions

With normalization, you specify the representation of the encoder value in the feedback interface.

- With “Positions” = 1, 2...12, you specify that trailing, irrelevant bits in the encoder value are to be discounted and the encoder is right-justified in the address area (see the following example).
- With “Positions” = 0, you specify that trailing bits are retained and are available for evaluation.

This can make sense if you use an absolute encoder, which transmits information in the bits located behind (see manufacturer specifications) and if you intend to evaluate this information (note chapter 5.4.5).

Steps/revolution parameter

A maximum of 13 bits are available for the steps / revolution. In accordance to the specification “Positions”, the resulting number of steps / revolution will be displayed.

Terminating the FREEZE function

You have to terminate the FREEZE function for each encoder input. Acknowledge the function in the user program by setting bit 0, 1 and 2 with the *STEP 7* operation T PAB “xyz” (for an example program refer to Section 5.4.9) according to the channel.

After acknowledgment, bit 31 of the corresponding encoder value is deleted and updated again. The encoder values can be frozen again.

The encoder values can be frozen again as soon as the acknowledgment bit in the output address of the module has been deleted.

In isochrone mode, acknowledgment is done at T_0 time. The encoder values can be frozen again via the digital outputs as from this period.

Note

The freeze function is acknowledged automatically if you reassign different parameters to the corresponding channel (see chapter 5.4.8).

The freeze function remains unaffected if the parameters are identical.

5.4.8 Assigning Parameters to the SM 338; POS-INPUT

You assign parameters to the SM 338; POS-INPUT in *STEP 7*. You must perform parameter assignment in STOP mode of the CPU.

When you have set all the parameters, download the parameters from the programming device to the CPU. On a transition from STOP to RUN mode, the CPU transfers the parameters to the SM 338.

It is not possible to reassign the parameters by means of the user program.

Parameters of the SM 338; POS-INPUT

You will find an overview of the programmable parameters and their default values for the SM 338 in the table below.

The default settings apply if you have not performed parameter assignment in *STEP 7* (the default appears in bold).

Table 5-3 Parameters of the SM 338; POS-INPUT

Parameter	Value Range	Remark
Enable		Enabling parameter.
• Diagnostic interrupt	Yes / no	Works for all 3 channels.
Encoder absolute (SSI) ¹	None; 13-bit ; 21-bit; 25-bit	None: The encoder input is switched off.

Table 5-3 Parameters of the SM 338; POS-INPUT

Parameter	Value Range	Remark
Code type ¹	Gray ; Binary	Code supplied by the encoder
Transmission rate ^{1,3}	125 kHz ; 250 kHz; 500 kHz; 1 MHz	Data transfer rate of the SSI position detection. Note the connection between the cable lengths and the baud rate (see Technical specifications)
Monoflop time ^{1,2,3}	16 μ s; 32 μ s; 48 μ s; 64 μs	The monoflop time is the interval between two SSI message frames. The programmed monoflop time must be greater than the monoflop time of the encoder absolute.
Normalizing ¹ <ul style="list-style-type: none"> • Positions • Steps / revolution ⁴ 	0 to 12 2 to 8192	On account of normalizing, the encoder is right-justified in the address area; irrelevant places are discarded.
Enable Freeze	Off ; 0; 1	Specification of the digital input, whose positive edge causes the encoder value to freeze.

¹ See the technical specifications of the absolute encoder.

² The monoflop time is the time between 2 SSI frames. The parameterized monoflop time must be greater than the monoflop time of the absolute encoder (refer to the technical specifications of the manufacturer). The time $2 \times (1 / \text{transmission rate})$ is added to the value parameterized in HWCONFIG. At a transmission rate of 125 kHz and a parameterized monoflop time of 16 μ s, a monoflop time of 32 μ s is in fact effective.

³ The following limitation applies to the monoflop time of the absolute encoder:

$(1 / \text{transmission rate}) < \text{monoflop time of the absolute encoder} < 64 \mu\text{s} + 2 \times (1 / \text{transmission rate})$

⁴ To the power of 2

Note

Note that the transmission rate and the monoflop time affect the accuracy and topicality of the encoder values in non isochrone mode.

In isochrone mode the transmission rate and the monoflop time affect the accuracy of the FREEZE function (refer to the technical specifications of the encoder manufacturer).

5.4.9 Addressing SM 338; POS-INPUT

Data areas for the encoder values

The inputs and outputs of the SM 338 are addressed as of the initial module address. You determine the input and output addresses during configuration of the SM 338 in *STEP 7*.

Input addresses

Table 5-4 SM 338; POS-INPUT: Input Addresses

Encoder Input	Input Address (from Configuration) + Address Offset
0	"Initial module address"
1	"Initial module address" + 4 bytes address offset
2	"Initial module address" + 8 bytes address offset

Structure of the data double word

The data double word is structured as follows at each encoder input:

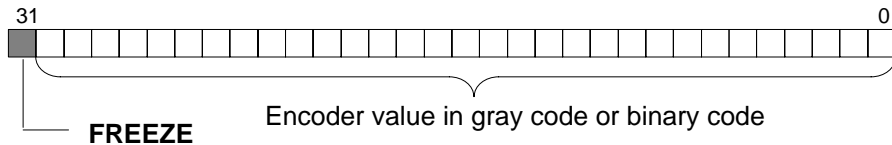

0 = encoder value is not frozen. The value is continuously updated.
 1 = encoder value is frozen. The value remains the same until acknowledgment.

Output address

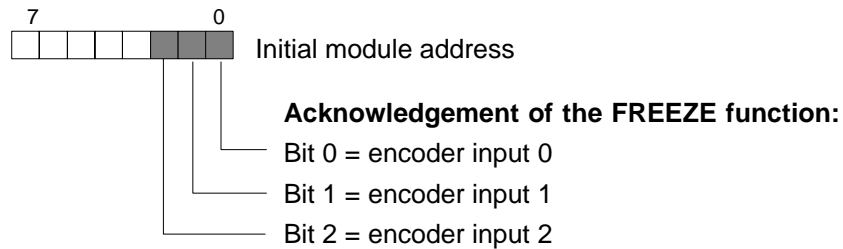

Reading out data areas

You can read out the data area in your user program with the *STEP 7* operation L PED "xyz".

Example of access to encoder values and use of the FREEZE function

You want to read out and evaluate the value of the encoder at the encoder inputs. The initial module address is 256.

STL				Explanation
L	PED	256	//	The encoder value in the address area for encoder input 0 is read.
T	MD	100	//	The encoder value is stored in the memory double word.
U	M	100.7	//	Determine and store FREEZE status for acknowledgement later
=	M	99.0	//	
L	PED	260	//	The encoder value in the address area for encoder input 1 is read.
T	MD	104	//	The encoder value is stored in the memory double word.
U	M	104.7	//	Determine and store FREEZE status for acknowledgement later
=	M	99.1	//	
L	PED	264	//	The encoder value in the address area for encoder input 2 is read.
T	MD	108	//	The encoder value is stored in the memory double word.
U	M	108.7	//	Determine and store FREEZE status for acknowledgement later
=	M	99.2	//	
L	MB	99	//	Load the FREEZE status and
T	PAB	256	//	acknowledge (SM 338: output address 256)

Afterwards you can further process the encoder values from the bit memory address area MD 100, MD 104 and MD 108. The encoder value is in bits 0 to 30 of the memory double word.

5.4.10 Diagnostics of the SM 338; POS-INPUT

The SM 338 makes diagnostic messages available. In other words, all diagnostic messages are provided by the SM 338 without your having to do anything.

Actions following diagnostic message in *STEP 7*

Each diagnostic message leads to the following actions:

- The diagnostic message is entered in the diagnosis of the module and forwarded to the CPU.
- The SF LED on the module lights.
- If you have programmed “Enable Diagnostic Interrupt” in *STEP 7*, a diagnostic interrupt is triggered and OB 82 is called.

Reading out diagnostic messages

You can read out detailed diagnostic messages by means of SFCs in the user program (refer to the Appendix “Diagnostic Data of Signal Modules”).

You can view the cause of the error in *STEP 7*, in the module diagnosis (refer to online Help for *STEP 7*).

Diagnostic message by means of SF LED

The SM 338 indicates errors by means of its SF-LED (group error LED). The SF LED lights as soon as a diagnostic message is triggered by the SM 338. It goes out when all errors have been rectified.

The group fault SF LED also lights up in case of external errors (short circuit of sensor supply), independent of the operating status of the CPU (if power is on).

The SF LED lights briefly during startup, during the SM 338 self-test.

Diagnostic messages of the SM 338; POS-INPUT

The table below gives an overview of the diagnostic messages for the SM 338; POS-INPUT.

Table 5-5 Diagnostic Messages of the SM 338; POS-INPUT

Diagnosics Message	LED	Scope of the Diagnostics
Module problem	SF	Module
Internal malfunction	SF	Module
External malfunction	SF	Module
Channel error present	SF	Module
External auxiliary supply missing	SF	Module
Module not parameterized	SF	Module
Wrong parameters	SF	Module
Channel information available	SF	Module
Time monitoring triggered	SF	Module
Channel error present	SF	Channel (encoder input)
Configuring/parameter assignment error	SF	Channel (encoder input)
External channel error (encoder error)	SF	Channel (encoder input)

Causes of errors and troubleshooting

Table 5-6 Diagnostic Messages of the SM 338, Causes of Errors and Troubleshooting

Diagnostics Message	Possible Error Cause	Remedy
Module malfunction	An error detected by the module has occurred	
Internal error	The module has detected an error within the programmable logic controller	
External error	The module has detected an error outside the programmable logic controller	
Channel error present	Indicates that only certain channels are faulty	
External auxiliary voltage missing	Power supply L+ to module missing	Feed supply L+
Module not parameterized	The module requires the information as to whether it should work with system default parameters or with your parameters	Message queued after power-on until parameter transmission by the COU has been completed; parameterize the module, as required
Wrong parameters	One parameter or the combination of parameters is not plausible	Reassign module parameter
Channel information present	Channel error present; the module can supply additional channel information	
Watchdog tripped	Temporary high electromagnetic interference	Eliminate interference
Channel error present	An error detected by the module has occurred at the encoder input	
Configuration/parameterization error	Illegal parameters transferred to module	Reassign module parameter
External channel error (encoder error)	Wire break of encoder cable, encoder cable not connected or encoder defective	Check connected encoder

5.4.11 Interrupts of the SM 338; POS-INPUT

Introduction

This section describes the interrupt behavior of the SM 338; POS-INPUT. The SM 338 can trigger diagnostic interrupts.

The OBs and SFCs mentioned below can be found in the online Help for *STEP 7*, where they are described in greater detail.

Enabling interrupts

The interrupts are not preset – in other words, they are inhibited without appropriate parameter assignment. Assign parameters to the Interrupt Enable in *STEP 7* (refer to Section 5.4.8).

Diagnostic interrupt

If you have enabled diagnostic interrupts, then active error events (initial occurrence of the error) and departing error events (message after troubleshooting all errors) are reported by means of an interrupt.

The CPU interrupts execution of the user program and processes the diagnostic interrupt block OB 82.

In the user program, you can call SFC 51 or SFC 59 in OB 82 to obtain more detailed diagnostic information from the module.

The diagnostic information is consistent until such time as OB 82 is exited. When OB 82 is exited, the diagnostic interrupt is acknowledged on the module.

5.4.12 Technical specifications of the SM 338; POS-INPUT

Dimensions and Weight	
Dimensions W x H x D (mm)	40 × 125 × 120
Weight	Approx. 235 g
Voltages, Currents, Potentials	
Rated load voltage L+	24 VDC
• Range	20.4 to 28.8 V
• Reverse polarity protection	No
Isolation	No, only from shield
Permitted potential difference	
• Between input (M connection) and central grounding point of CPU	1 VDC
Encoder supply	
• Output voltage	L+ -0,8V
• Output current	max. 900 mA short circuit-proof
Current consumption	
• From the backplane bus	max. 160 mA
• From the load voltage L+ (no load)	max. 10 mA
Power dissipation of the module	typ. 3W
Encoder Inputs POS-INPUT 0 to 2	
Position detection	Absolute
Differential signals for SSI data and SSI clock	According to RS422
Data transmission rate and line length with absolute encoders (twisted and shielded pair)	<ul style="list-style-type: none"> • 125 kHz max. 320 m • 250 kHz max. 160 m • 500 kHz max. 60 m • 1 MHz max. 20 m
Frame time of the encoders	13-bit 21-bit 25-bit
• 125 kHz	112 μs 176 μs 208 μs
• 250 kHz	56 μs 88 μs 104 μs
• 500 kHz	28 μs 44 μs 52 μs
• 1 MHz	14 μs 22 μs 26 μs
Monoflop time ²	16 μs, 32 μs, 48 μs, 64 μs
Digital inputs DI 0, DI 1	
Isolation	No, only from shield
Input voltage	0 signal: -3 V to 5 V 1 signal: 11 V to 30.2 V
Input current	0 signal: ≤ 2 mA (closed-circuit current) 1 signal: 9 mA (typically)
Input delay	0 > 1: max. 300 μs 1 > 0: max. 300 μs
Maximum repetition frequency	1 kHz
Connection of a two-wire BERO type 2	Possible
Shielded line length	600 m
Unshielded line length	32 m
Status, Interrupts, Diagnostics	
Interrupts	
• Diagnostic Interrupt	Parameters can be assigned
Status display for digital inputs	LED (green)
Group error/fault	LED (red)
Unsharpness of Encoder Value	
Free-running encoder value detection	
• Maximum Age ¹	(2 × frame time) + monoflop time + 580 μs
• Minimum Age ¹	Frame time + 130 μs
• Jitter	Frame time + monoflop time + 450 μs
Update rate	Evaluation of the frame every 450 μs
Isochrone encoder value detection	
• Age	Encoder value at time T _i in the current PROFIBUS DP cycle
Unsharpness of freezed Encoder Value (FREEZE)	
Free-running encoder value detection	
• Maximum Age ¹	(2 × frame time) + monoflop time + 580 μs
• Minimum Age ¹	Frame time + 130 μs
• Jitter	Frame time + monoflop time + 450 μs
Update rate	Evaluation of the frame every 450 μs
Isochrone encoder value detection	
• Jitter	Max (Frame time _n + param. Monoflop time _n) n = 0, 1, 2, (Channel)

¹ Age of the encoder values determined by the method of transmission and the processing

² The following limitation applies to the monoflop time of the absolute encoder: (1 / transmission rate) < monoflop time of the absolute encoder < 64 μs + 2 × (1 / transmission rate)

6

Interface Modules

Interface modules

In this chapter you will find the technical specifications and characteristic features of the interface modules for the S7-300.

Contents

The following interface modules are described in this chapter:

Section	Contents	Page
6.1	Module Overview	6-2
6.2	Interface Module IM 360; (6ES7 360-3AA01-0AA0)	6-3
6.3	Interface Module IM 361; (6ES7 361 3CA01-0AA0)	6-5
6.4	Interface Module IM 365; (6ES7 365-0BA01-0AA0)	6-7

6.1 Module Overview

Introduction

The following table summarizes the most important characteristics of the interface modules described in this chapter. This overview is intended to make it easy to choose the suitable module for your task.

Table 6-1 Interface Modules: Characteristics at a Glance

Module Characteristics	Interface Module IM 360	Interface Module IM 361	Interface Module IM 365
Suitable for plugging into S7-300 mounting racks	<ul style="list-style-type: none"> • 0 	<ul style="list-style-type: none"> • 1 to 3 	<ul style="list-style-type: none"> • 0 and 1
Data transmission	<ul style="list-style-type: none"> • From IM 360 to IM 361 over the connecting cable 386 	<ul style="list-style-type: none"> • From the IM 360 to the IM 361 or from the IM 361 to the IM 361 via connecting cable 386 	<ul style="list-style-type: none"> • From IM 365 to IM 365 via connecting cable 386
Distance between...	<ul style="list-style-type: none"> • Max. 10 m 	<ul style="list-style-type: none"> • Max. 10 m 	<ul style="list-style-type: none"> • 1 m, permanently connected
Special Features	---	---	<ul style="list-style-type: none"> • Preassembled module pair • Install only signal modules in rack 1 • IM 365 does not route the communication bus to subrack 1

6.2 Interface Module IM 360; (6ES7 360-3AA01-0AA0)

Order number

6ES7 360-3AA01-0AA0

Characteristics

The interface module IM 360 has the following characteristic features:

- Interface for rack 0 of the S7-300
- Data transfer from IM 360 to IM 361 over the connecting cable 368
- Maximum distance between IM 360 and IM 361 is 10 m (32.8 ft.)

Status and fault LEDs

The interface module IM 360 has the following status and fault LEDs.

LED	Meaning	Explanation
SF	Group error/fault	The LED lights up if <ul style="list-style-type: none">• the connecting cable is missing.• IM 361 is switched off.

Front view

Figure 6-1 shows the front view of the interface module IM 360.

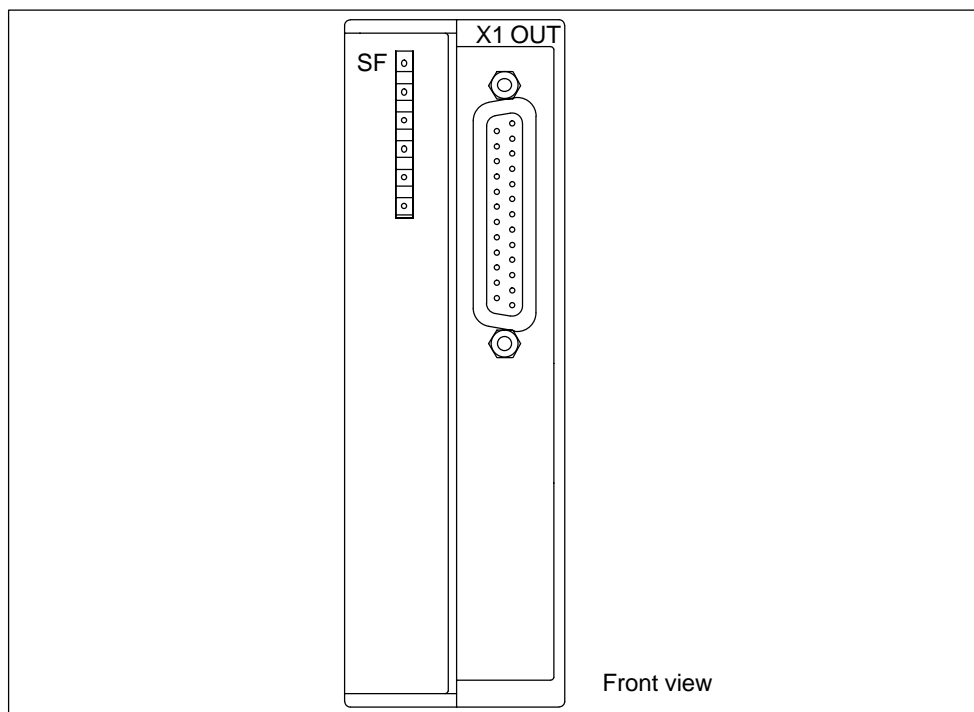

Figure 6-1 Front View of the Interface Module IM 360

Technical specification

The following overview lists the technical specifications for the interface module IM 360.

Dimensions and Weight	
Dimensions W × H × D (in millimeters)	40 × 125 × 120
Weight	Approx. 250 g
Data for Specific Module	
Length of cable	
• Maximum length to next IM	10 m
Current consumption	
• From the backplane bus	350 mA
Power loss	typ. 2 W
Status and fault LEDs	Yes

6.3 Interface Module IM 361; (6ES7 361 3CA01-0AA0)

Order number

6ES7 361 3CA01-0AA0

Characteristics

The interface module IM 361 has the following characteristic features:

- 24 VDC power supply
- Interface for racks 1 to 3 of the S7-300
- Current output via the S7-300 backplane bus max. 0.8 A
- Data transfer from the IM 360 to the IM 361 or from the IM 361 to the IM 361 via connecting cable 368
- Maximum distance between IM 360 and IM 361 is 10 m (32.8 ft.)
- Maximum distance between IM 361 and IM 361 is 10 m

Status and fault LEDs

The interface module IM 361 has the following status and fault LEDs.

LED	Meaning	Explanation
SF	Group error/fault	The LED lights up if <ul style="list-style-type: none"> • the connecting cable is missing • the series-connected IM 361 is switched off • the CPU is in the POWER OFF state
5 VDC	5 VDC supply for the S7-300 backplane bus	–

Front view

Figure 6-2 shows the front view of the interface module IM 361.

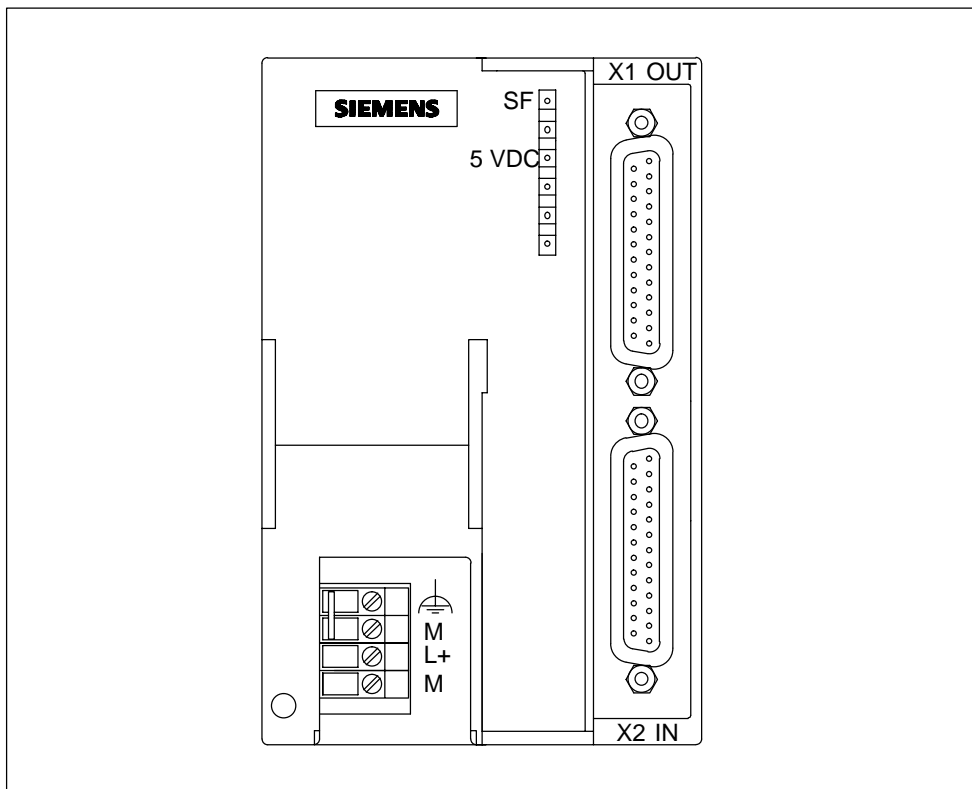

Figure 6-2 Front View of the Interface Module IM 361

Technical specification

The following overview lists the technical specifications for the interface module IM 361.

Dimensions and Weight	
Dimensions W × H × D (in millimeters)	80 × 125 × 120
Weight	505 g
Data for Specific Module	
Length of cable	
Maximum length to next IM	10 m
Current consumption	
From 24 VDC	0.5 A
Power loss	typ. 5 W
Current output	
To backplane bus	0.8 A
Status and fault LEDs	Yes

6.4 Interface Module IM 365; (6ES7 365-0BA01-0AA0)

Order number

6ES7 365-0BA01-0AA0

Characteristics

The interface module IM 365 has the following characteristic features:

- Pre-assembled pair of modules for rack 0 and rack 1
- Total power supply of 1.2 A, of which up to 0.8 A can be used per rack.
- Connecting cable with a length of 1 m already permanently connected
- Install only signal modules in rack 1
- IM 365 does **not** forward the C bus to rack 1, i.e. you cannot plug FMs with a C bus function in rack 1.

Front view

Figure 6-3 shows the front view of the interface module IM 365.

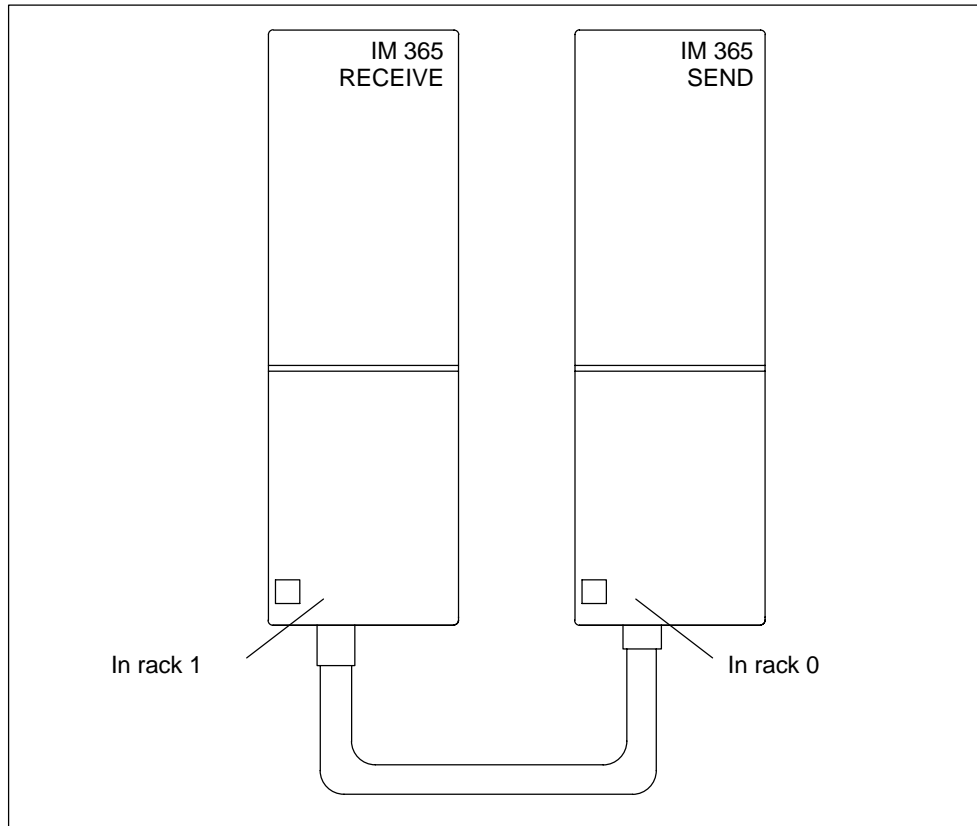

Figure 6-3 Front View of the Interface Module IM 365

Technical specification

The following overview lists the technical specifications for the interface module IM 365.

Dimensions and Weight		Data for Specific Module	
Dimensions W × H × D per rack (in millimeters)	40 × 125 × 120	Length of cable	
Total weight	580 g	Maximum length to next IM	1 m
		Current consumption	
		From the backplane bus	100 mA
		Power loss	typ. 0.5 W
		Current output	max. 1.2 A
		Per rack	0.8 A
		Status and fault LEDs	No

RS 485 Repeater

In this chapter

In this chapter, you will find a detailed description of the RS 485-Repeater.

Included in the description are:

- The purpose of the RS 485 repeater
- The maximum cable lengths possible between two RS 485 repeaters
- The functions of the individual operating elements and terminals
- Information about grounded and non-grounded operation
- Technical specifications and the block diagram

Further information

You will find further information on the RS 485 repeater in the manuals *Hardware and Installation* in the Chapter "Configuring of an MPI or PROFIBUS-DP network".

Diagnostic repeater

Compared to the RS 485 repeater, the diagnostic repeater has new characteristics: Diagnostic function and modeling as the DP slave. For additional information, refer to the *Diagnostic Repeater for PROFIBUS-DP* manual, order no. 6ES7 972-0AB00-8xA0.

In this chapter

Section	Contents	Page
7.1	Application and Characteristics; (6ES7 972-0AA01-0XA0)	7-2
7.2	Appearance of the RS-485 Repeater; (6ES7 972-0AA01-0XA0)	7-3
7.3	RS 485 Repeater in Ungrounded and Grounded Operation	7-4
7.4	Technical Specification	7-7

7.1 Application and Characteristics; (6ES7 972-0AA01-0XA0)

Order number

6ES7 972-0AA01-0XA0

What is an RS 485 repeater?

The RS 485 repeater amplifies data signals on bus lines and interconnects bus segments.

Application of the RS 485 repeater

You need an RS 485 repeater if:

- More than 32 nodes are connected to the bus
- Bus segments are to be operated non-grounded on the bus, or
- The maximum cable length of a segment is exceeded. (See table 7-1).

Table 7-1 Maximum Cable Length of a Segment

Baud Rate	Max. Cable Length of a Segment (in m)
9.6 to 187.5 kbd	1000
500 kbaud	400
1.5 Mbaud	200
3 to 12 Mbaud	100

Rules

If you configure the bus with RS 485 repeaters:

- Up to 9 RS 485 repeaters can be connected in series.
- The maximum cable length between two nodes must not exceed the values in Table 7-2.

Table 7-2 Maximum Cable Length between Two RS 485 Repeater

Baud Rate	Maximum Length of Cable between 2 Nodes (in m) with RS 485 Repeater (6ES7 972-0AA01-0XA0)
9.6 to 187.5 kbaud	10000
500 kbaud	4000
1.5 Mbaud	2000
3 to 12 Mbaud	1000

7.2 Appearance of the RS 485 Repeater; (6ES7 972-0AA01-0XA0)

The table below shows the appearance of the RS 485 repeater and lists its functions.

Table 7-3 Description and Functions of the RS 485 Repeater

Repeater Design	No.	Function
<p>The diagram shows the front panel of the Siemens RS 485 Repeater. At the top, there is a power supply section with terminals labeled 24 VDC, L+, M, PE, and M5.2. Below this is a shield clamp. The middle section features two bus cable terminals for bus segment 1 (A1, B1) and bus segment 2 (A2, B2). A central switch is labeled ON, OFF, and ON. Two DP1 and DP2 terminals are also present. At the bottom, there is a mounting slide and an interface for a programming device/OP. An LED is located at the top left, and two more LEDs are at the bottom.</p>	①	Connection for the RS 485 repeater power supply (pin "M5.2" is the ground reference, if you want to measure the voltage difference between terminals "A2" and "B2").
	②	Shield clamp for the strain relief and grounding of the bus cable of bus segment 1 or bus segment 2
	③	Terminals for the bus cable of bus segment 1
	④	Terminating resistance for bus segment 1
	⑤	Switch for OFF operating mode (= isolate bus segments from each other – for example, for startup)
	⑥	Terminating resistance for bus segment 2
	⑦	Terminals for the bus cable of bus segment 2
	⑧	Slide for mounting and removing the RS 485 repeater on the standard rail
	⑨	Interface for programming device/OP in bus segment 1
	⑩	LED 24 V supply voltage
	⑪	LED for bus segment 1
	⑫	LED for bus segment 2

7.3 RS 485 Repeater in Ungrounded and Grounded Operation

Grounded or ungrounded

The RS 485 repeater is ...

- Grounded, if all other nodes in the segment are also operated with a grounded potential
- Ungrounded, if all other nodes in the segment are operated with an ungrounded potential

Note

The bus segment 1 is grounded if you connect a programming device to the PG/OP socket of the RS 485 repeater. Ground connection is effected since the MPI in the programming device is grounded and the PG/OP socket is connected internally with bus segment 1 in the RS 485 repeater.

Grounded operation of the RS 485 repeater

For grounded operation of the RS 485 repeater, you must jump terminals "M" and "PE" on the top of the RS 485 repeater.

Ungrounded operation of the RS 485 repeater

For ungrounded operation of the RS 485 repeater, "M" and "PE" on the top of the RS 485 repeater must not be interconnected. In addition, the supply voltage of the RS 485 repeater must be ungrounded.

Terminal connection diagram

In the case of a repeater configuration with ungrounded reference potential (ungrounded operation), any interference currents and static charges are discharged by means of an RC network integrated in the repeater (refer to Figure 7-1) to the protective conductor.

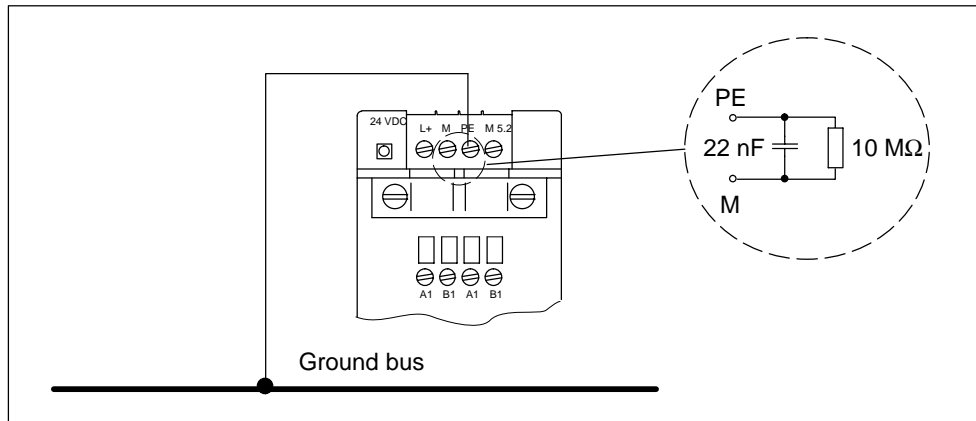

Figure 7-1 RC Network with 10 MΩ for Configuration with Ungrounded Reference Potential

Isolation between bus segments

Bus segment 1 and bus segment 2 are galvanically isolated from each other. The PG/OP interface is connected internally to the port for bus segment 1. Figure 7-2 shows the front panel of the RS 485 repeater.

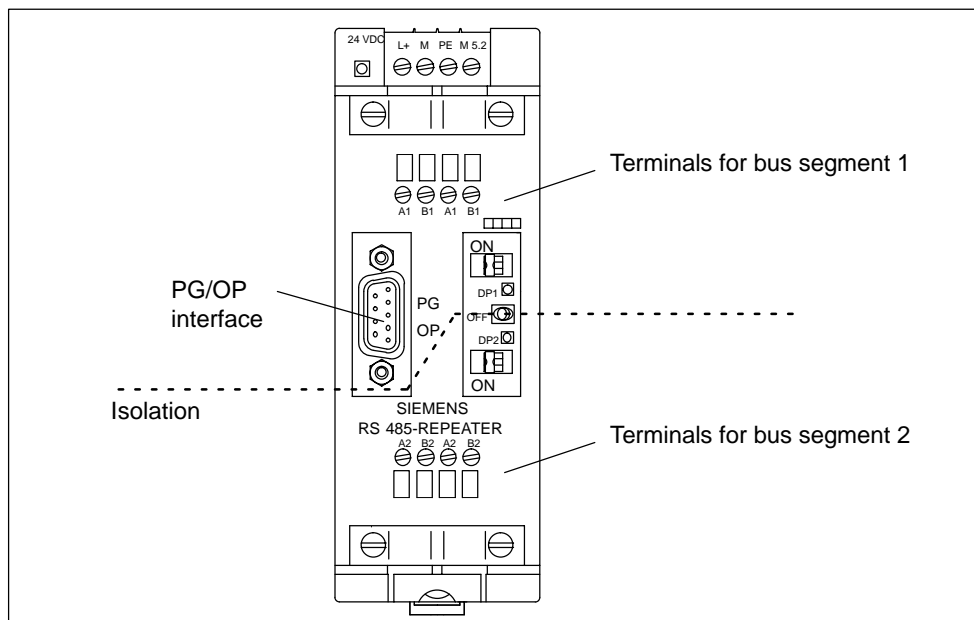

Figure 7-2 Isolation between the Bus Segments

Amplification of the bus signals

The amplification of the bus signals takes place between the port for bus segment 1 or the PG/OP interface and the port for bus segment 2.

7.4 Technical Specifications

Technical specifications of the RS 485 repeater

Technical Specification	
Power supply	
• Rated voltage	24 VDC
• Ripple	20.4 to 28.8 VDC
Current consumption at rated voltage	
• Without node at PG/OP socket	100 mA
• Node at PG/OP socket (5 V/90 mA)	130 mA
• Node at PG/OP socket (24 V/100 mA)	200 mA
Isolation	Yes, 500 VAC
Connection of fiber optic cables	Yes, via repeater adapters
Redundancy operation	No
Transmission rate (automatically detected by the repeater)	9.6 kbaud, 19.2 kbaud, 45.45 kbaud, 93.75 kbaud, 187.5 kbaud, 500 kbaud, 1.5 Mbaud, 3 Mbaud, 6 Mbaud, 12 Mbaud
Degree of protection	IP 20
Dimensions W × H × D	45 × 128 × 67
Weight (incl. packaging)	350 g

Pin assignment of the sub-D connector (PG/OP socket)

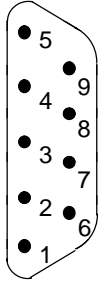
View	Pin No.	Signal Name	Designation
	1	–	–
	2	M24V	Ground 24 V
	3	RxD/TxD-P	Data line B
	4	RTS	Request To Send
	5	M5V2	Data reference potential (from station)
	6	P5V2	Supply plus (from station)
	7	P24V	24 V
	8	RxD/TxD-N	Data line A
	9	–	–

Block diagram of the RS 485 repeater

- Bus segment 1 and bus segment 2 are galvanically isolated from each other.
- Bus segment 2 and the PG/OP socket are galvanically isolated from each other.
- Signals are amplified
 - between bus segment 1 and bus segment 2
 - between PG/OP socket and bus segment 2

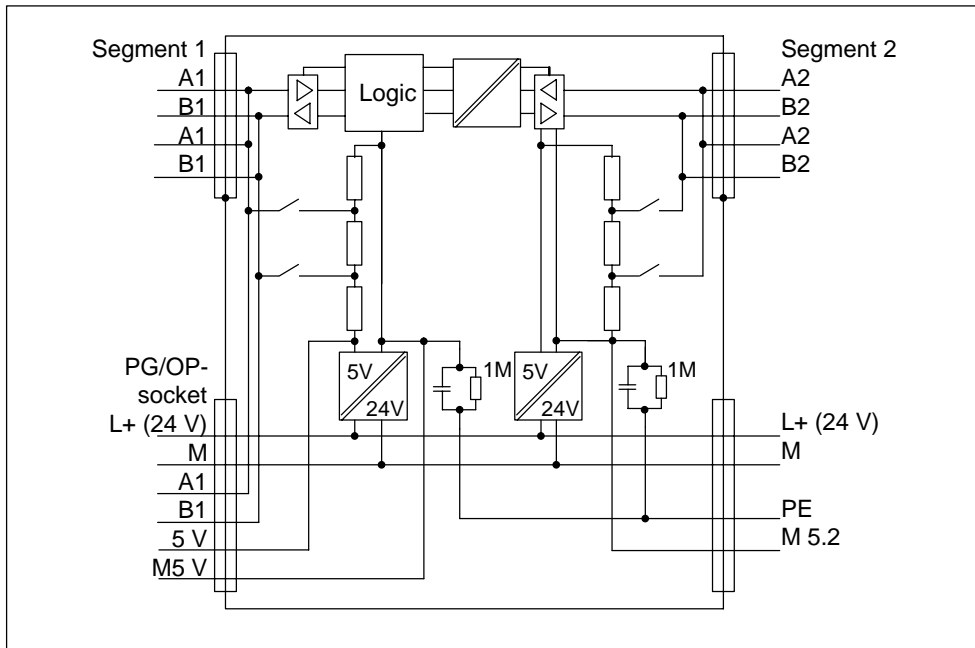

Figure 7-3 Block Diagram of the RS 485 Repeater

SIMATIC TOP connect and SIMATIC TOP connect TPA

8

Changes and improvements compared with the last edition of the Reference Manual

The descriptions of SIMATIC TOP connect and SIMATIC TOP connect TPA are summarized in this chapter. In this way it was possible to extract and give precedence to generally valid information.

A new overview section will make it easier for you to access the information.

The section entitled "Module Overview" shows the basic configuration of SIMATIC TOP connect and SIMATIC TOP connect TPA. In addition, you will also find out which modules in the S7-300 family can be used with SIMATIC TOP connect/... TPA.

In this chapter

Section	Contents	Page
8.1	Module Overview	8-2
8.2	Wiring Components	8-4
8.3	Wiring SIMATIC TOP connect with Digital Modules	8-12
8.4	Wiring SIMATIC TOP connect TPA with Analog Modules	8-20

Structure of the chapter

Sections 8.1 and 8.2 apply to SIMATIC TOP connect and SIMATIC TOP connect TPA.

Section 8.3 contains specific information on SIMATIC TOP connect and thus supplements the preceding sections.

Section 8.4 contains specific information on SIMATIC TOP connect TPA and thus supplements Sections 8.1 und 8.2.

8.1 Module Overview

Introduction

"SIMATIC TOP connect" denotes components for wiring digital modules.

"SIMATIC TOP connect TPA" denotes components for wiring analog modules.

Wiring

Wiring with SIMATIC TOP connect/... TPA is a fast and cost-effective alternative to conventional wiring of the actuators and sensors directly at the front connector of the module. When using these components, you wire actuators and sensors "in situ" on one more terminal blocks. You establish the connection to the module by means of a connecting cable (round-sheath ribbon cable).

Configuration of SIMATIC TOP connect with a S7-300

A SIMATIC TOP connect and a SIMATIC TOP connect TPA always consist of:

- A front connector module with flat ribbon connection ①,
- One or more terminal blocks ③ and
- One or more connecting cables with plug-and-socket connectors at ends ②

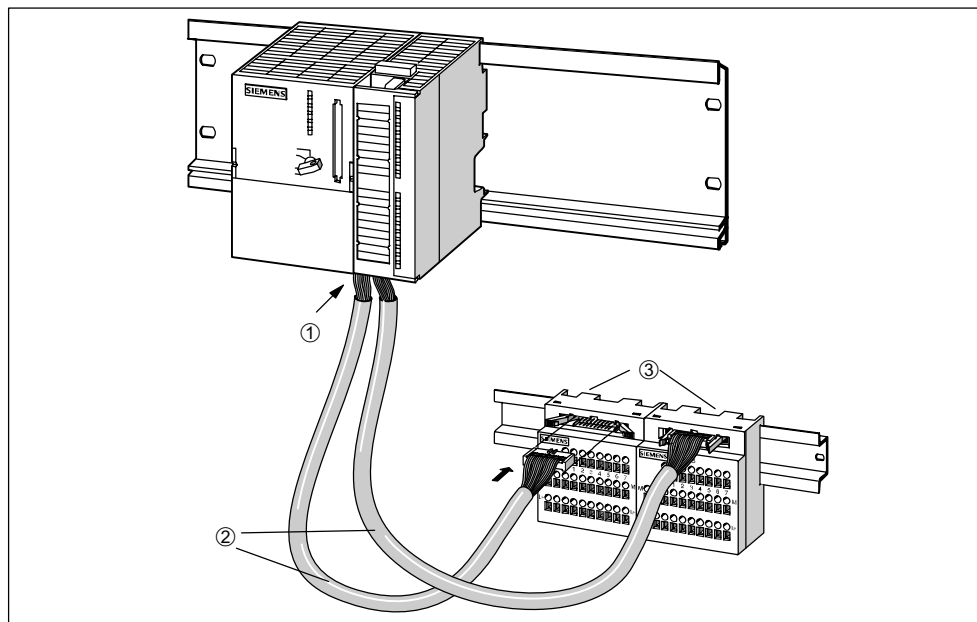

Figure 8-1 SIMATIC TOP connect on a S7-300

Advantages

Use of SIMATIC TOP connect/... TPA features the following advantages:

- Fast, low-cost wiring (the use of central terminal blocks is no longer necessary)
- Simple mounting of the components (front connector module, connecting cable, terminal block)
- Each component can be replaced separately
- Connecting cable configurable without waste
- Wiring errors are drastically reduced
- Neat and tidy cabinet wiring
- The supply voltage for the module can be connected to components of SIMATIC TOP connect/... TPA
- Simplification of the terminals for M- and L+ connection

Range of modules

The table below lists all the modules which you can wire with SIMATIC TOP connect and SIMATIC TOP connect TPA.

You will find a detailed list of the components of SIMATIC TOP connect/... TPA with their order numbers in Table 8-5 on page 8-12 and Table 8-13 on page 8-20.

Table 8-1 SIMATIC TOP connect/... TPA: Connectable Modules

Component	Front view of terminal block	Wiring possible with module...
SIMATIC TOP connect		SM 321; DI 32 × DC 24 V
		SM 321; DI 16 × DC 24 V
		SM 321; DI 16 × 24 VDC; source input
		SM 322; DO 32 × DC 24 V/0.5 A
SIMATIC TOP connect TPA		SM 322; DO 16 × DC 24 V/0.5 A
		SM 322; DO 8 × 24 VDC/0.5 A with diagnostic interrupt
		SM 322; DO 8 × DC 24 V/2 A
		SM 323; DI 16/DO 16 × DC 24 V/0.5 A
SIMATIC TOP connect TPA		SM 323; DI 8/DO 8 × DC 24 V/0.5 A
		SM 331 analog input module; AI 2 × 12 bits
		SM 331; AI 8 × 12bits
		SM 332; AO 4 × 12bits
		SM 332 analog output module; AO 2 × 12 bits
		SM 332; AO 4 × 16bits
		SM 334; AI 4/AO 2 × 8/8bits
SM 334; AI 4/AO 2 × 12bits		
SM 335; AI 4/AO 4 × 14 bits;		

8.2 Wiring Components

Introduction

The following table contains the tasks that you have to perform one after the other to commission SIMATIC TOP connect/... TPA successfully.

The sequence of steps is a suggestion but you can perform individual steps sooner or later.

Sequence of steps for wiring

Table 8-2 Sequence of Steps for Wiring SIMATIC TOP connect/... TPA

Step	Procedure	Refer to Section...
1.	Cut connecting cable to length and terminate	8.2.1
2.	Wire the front connector module	8.2.2 and 8.3 or 8.4
3.	Connect the connecting cable to the terminal block	8.2.3 and 8.3 or 8.4
4.	Wire actuators/sensors to the terminal block	8.2.4

8.2.1 Cut the Connecting Cable to Length and Terminate

Maximum length of cable

The length of the connecting cable (round-sheath ribbon cable) between the SIMATIC S7 and the terminal blocks must not be more than 30 m.

Using the connectors

You must attach connectors to either end of the round-sheath ribbon cable, for connection to the front connector module and the terminal block.

Connect the round-sheath ribbon cable to connector

1. Cut the round-sheath ribbon cable to the length required and remove part of the cable sheath at both ends.

You will find the length of the cable sheath that has to be removed in the following table:

Cable end to ...		Cable sheath to be removed		external ribbon cable	internal ribbon cable	external ribbon cable	internal ribbon cable
		20-pin front connector	40-pin front connector	20-pin front connector		40-pin front connector	
... top connector of front connector module	1 x 16 core shielded/uns shielded	110 mm	115 mm				
... bottom connector of front connector module		70 mm	75 mm				
... top connector of front connector module	2 x 16 core unshielded	95 mm	115 mm	95 mm		115 mm	
... bottom connector of front connector module					40 mm		75 mm
... socket of terminal block		40 mm		100 mm			

2. Thread the cable into the 16-pin connector.

It is important that you note the position of the details marked in the following figure.

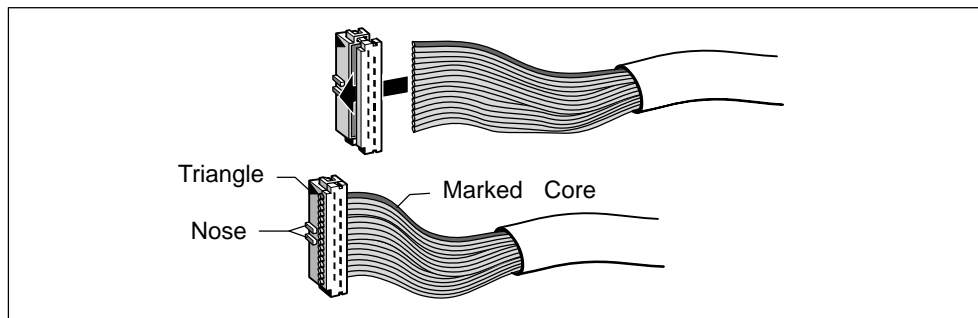

Figure 8-2 Threading the Round-Sheath Ribbon Cable into the Connector

3. Clamp the end of the cable into the connector with the crimping tool.
4. Attach the strain relief device to the connector of the terminal block as follows:
 - Fold back the cable over the connector
 - Push the enclosed strain relief device over the cable
 - Snap the strain relief device into place on the connector

8.2.2 Wiring the Front Connector Module

Introduction

This chapter describes the principle of wiring the front connector modules. Note also the special sections for SIMATIC TOP connect and SIMATIC TOP connect TPA (Section 8.3 and 8.4, respectively). In those sections, you will find, among other things, selection criteria for the front connector modules and specific connection examples.

Using the front connector module

You require the front connector module to connect the connecting cable to the module. In addition, you can connect the supply voltage of the module to the front connector module.

Wiring rules for connecting the supply voltage

The following table shows you what you have to consider when connecting the module supply voltage to the terminal block or front connector module.

The terminals for the supply voltage are screws or spring-loaded terminals (refer to Section 8.2.4 for handling spring-loaded terminals).

Table 8-3 Wiring Rules for Connecting the Supply Voltage

Rules for ...	Terminal block		Front connector	
	Spring-loaded connection	Screw-type connection	Up to 4 Terminals	Up to 8 Terminals
Conductor cross-sections suitable for connection:				
Solid conductors	No		No	No
Stranded conductors				
• Without end ferrules	0.25 to 1.5 mm ²		0.25 to 1.5 mm ²	0.25 to 0.75 mm ²
• With end ferrules	0.25 to 1.5 mm ²		0.25 to 1.5 mm ²	0.25 to 0.75 mm ²
No of conductors per terminal	1 or combination of 2 conductors up to 1.5 mm ² (sum) in a common end ferrule			
Max. diameter of conductor insulation	Ø 3.1 mm		Ø 3.1 mm	Ø 2.0 mm
Length of conductor insulation to be stripped				
• Without insulation collar	11 mm		6 mm	
• With insulation collar	11 mm		–	
End ferrules to DIN 46228				
• Without insulation collar	Model A; up to 12 mm long	Model A; up to 12 mm long	Model A; 5 to 7 mm long	
• With insulation collar			–	
– 0.25 to 1.0 mm ²	Model E; up to 12 mm long	Model E; up to 12 mm long		
– 1.5 mm ²	Model E; 12 mm long	Model E; 18 mm long		

Connect the connecting cable and the supply voltage to the front connector module

1. Open the front door of the module.
2. Bring the front connector into the wiring position.
3. If necessary, connect the cables for the incoming supply of the module supply voltage.
4. Insert the connecting cable into the front connector module as shown in the following figure:

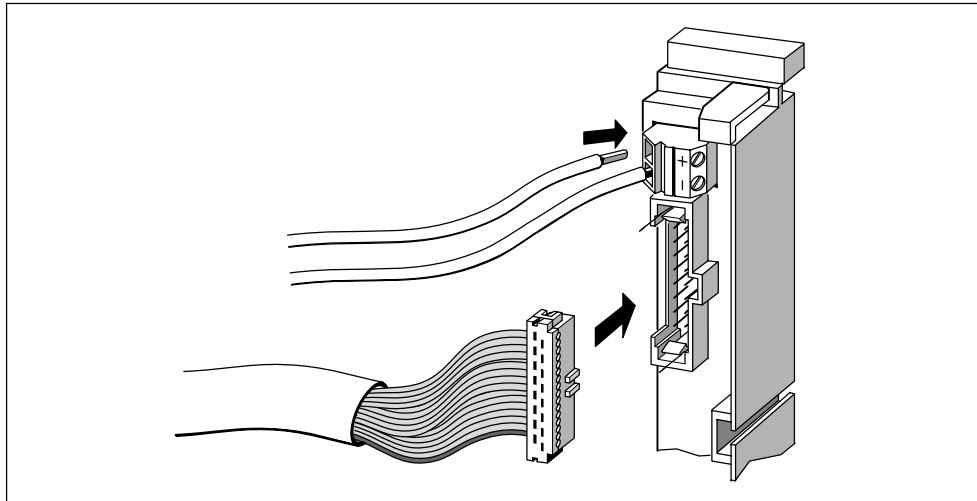

Figure 8-3 Inserting the Connecting Cable into the Front Connector Module

5. Twist every connecting cable 90° downwards and turn through one whole turn to the extent possible.

Additional steps for wiring for 32-channel digital modules

Note

When using 32-channel digital modules, you must observe the assignment of the supply connections to the connecting cable terminals and the assignment of the connecting cable terminals to the address bytes of the module (refer to Figure 8-4 and Table 8-4).

6. Thread a strain relief assembly into the middle of the front connector. This strain relief assembly is used to fix the connecting cables in the narrow cable stowage area of the module.
7. Thread the strain relief assembly into the front connector.

Front connector module for 32-channel digital modules

The following figure shows the front view of the front connector module for 32-channel digital modules.

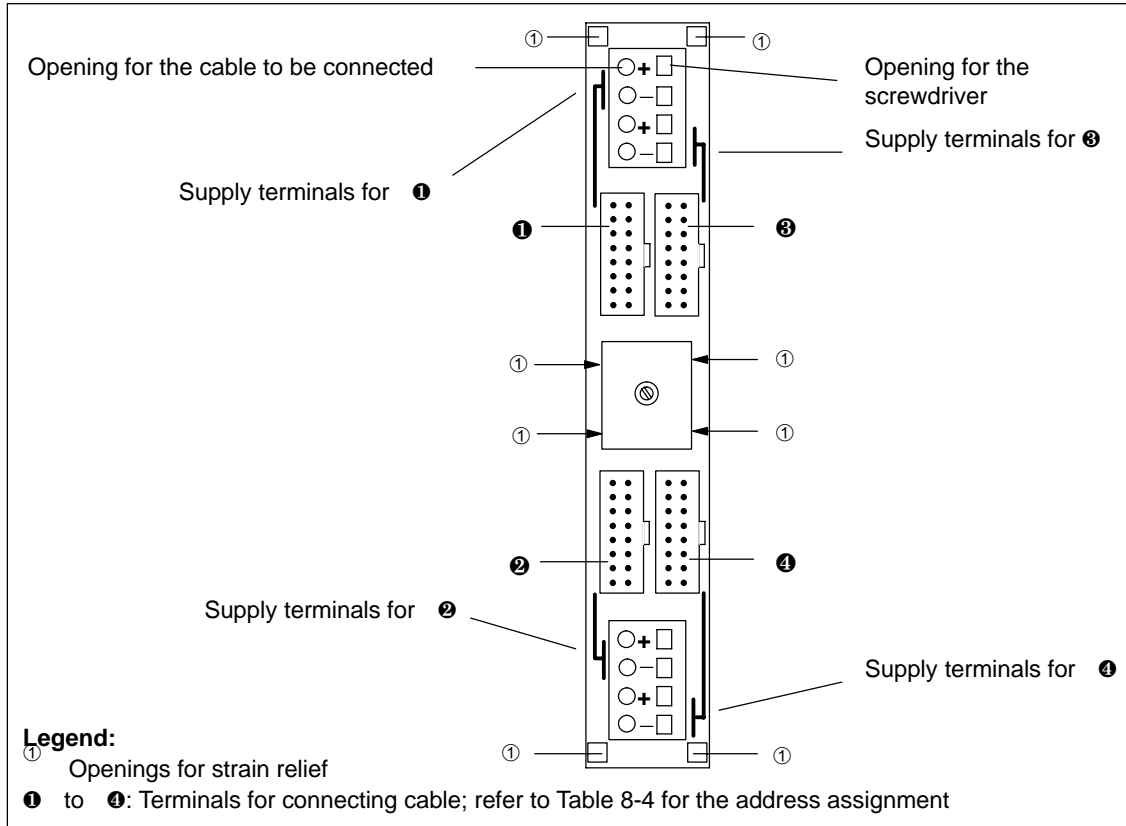

Figure 8-4 Front connector module for 32-channel digital modules

Assignment of connecting cable terminals to address bytes of 32-channel digital modules

Table 8-4 Assignment of Connecting Cable Terminals to Address Bytes of 32-Channel Digital Modules

Refer to Figure 8-4: Connecting Cable Terminal	Address Assignment for		
	Digital Input Module	Digital Output Module	Digital Input/Output Module
❶	IB x	QB x	IB x
❷	IB (x+1)	QB (x+1)	IB (x+1)
❸	IB (x+2)	QB (x+2)	QB x
❹	IB (x+3)	QB (x+3)	QB (x+1)

8.2.3 Connecting the Connecting Cable to the Terminal Block

Introduction

A description of how to mount the terminal blocks is presented in the following. Note also the special sections for SIMATIC TOP connect and SIMATIC TOP connect TPA (Section 8.3 and 8.4, respectively). In those sections, you will find, among other things, selection criteria for the different terminal blocks and specific connection examples.

Mounting the terminal block and connecting cable

1. Attach the terminal block to a 35 mm standard rail in accordance with EN 50 022.
2. Insert the connecting cable into the terminal block as shown in the following figure:

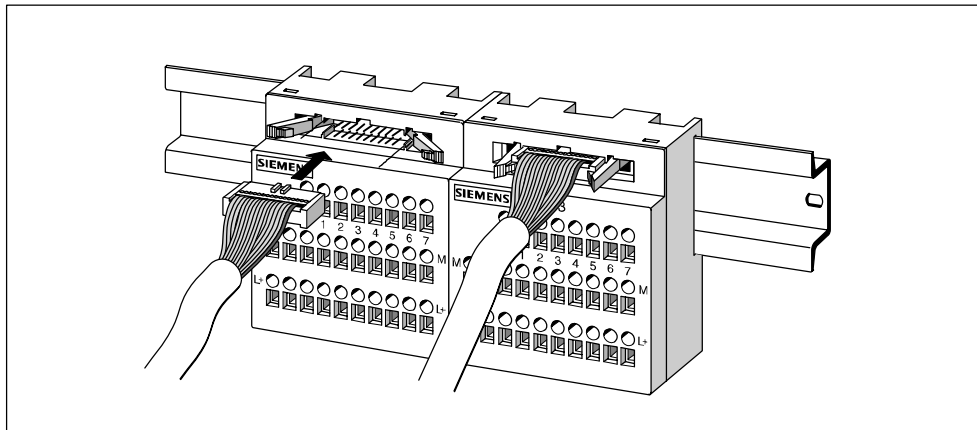

Figure 8-5 Insert the Connecting Cable into the Terminal Block

8.2.4 Wiring Actuators/Sensors to the Terminal Block

Screw-type or spring-loaded terminals

To mount the signal leads of the actuators/sensors to the terminal block and the supply lines to the terminal block and front connector module, you can choose between screw-type and spring-loaded components.

The principle of spring-loaded components is dealt with in greater detail in the following, since it allows fast and simple connection of the signal lines and supply cables.

Spring-loaded terminal block

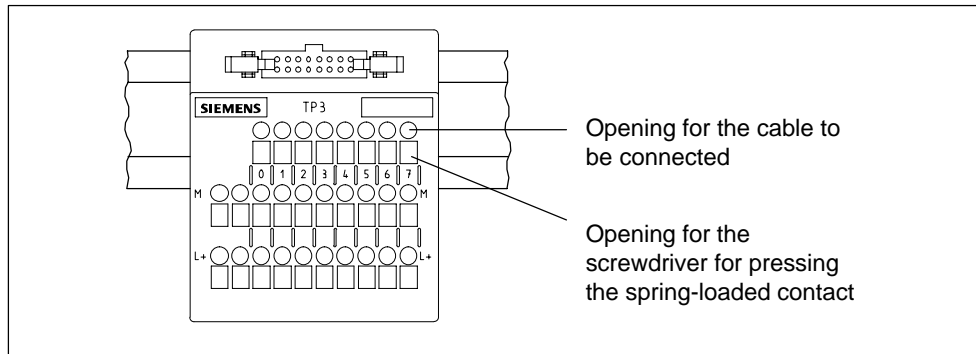

Figure 8-6 Spring-Loaded Terminal Block



Caution

The spring-loaded contact will be damaged, if you insert the screwdriver into the opening for the cable.

Make sure that you insert the screwdriver only into the rectangular opening of the terminal block.

Attaching the cable to the spring-loaded contact

Attach the cables to the spring-loaded contacts as follows:

1. Use a screwdriver ① to press down the spring-loaded terminal in the rectangular opening and to hold it down.
2. Insert the cable ② into the round opening of the corresponding spring-loaded terminal as far as it will go.
3. Remove the screwdriver ③ from the spring-loaded terminal. The cable is held by the spring-loaded contact.

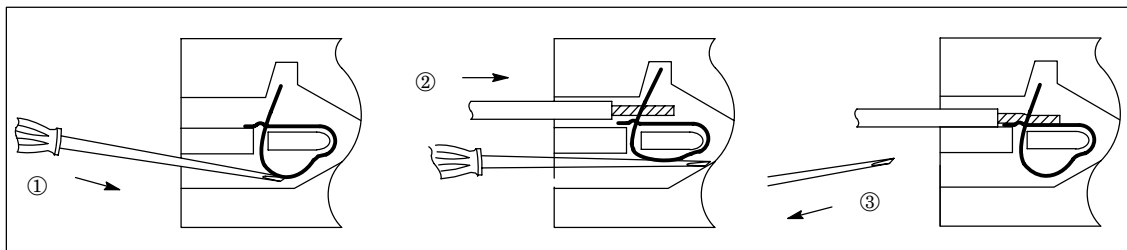

Figure 8-7 Principle of Spring-Loaded Connections

8.3 Wiring SIMATIC TOP connect with Digital Modules

Introduction

For wiring the module with actuators/sensors using SIMATIC TOP connect, you must first select the components as a function of the module and method of connection (screw type or spring-loaded terminal, one-conductor, three-conductor or 2A connection; relay).

8.3.1 SIMATIC TOP connect Components and Selection Aid

Components

The following table contains all the component of SIMATIC TOP connect.

Table 8-5 Components of SIMATIC TOP connect

Components of SIMATIC TOP connect			Order number
Terminal block	... for one-conductor connection	Spring-loaded screw-type	6ES7 924-0AA00-0AB0 6ES7 924-0AA00-0AA0
	... for one-conductor connection (10 items)	Spring-loaded screw-type	6ES7 924-0AA00-1AB0 6ES7 924-0AA00-1AA0
	... for three-conductor connection	Spring-loaded screw-type	6ES7 924-0CA00-0AB0 6ES7 924-0CA00-0AA0
	... for three-conductor connection (10 items)	Spring-loaded screw-type	6ES7 924-0CA00-1AB0 6ES7 924-0CA00-1AA0
	... for 2A modules	Spring-loaded screw-type	6ES7 924-0BB00-0AB0 6ES7 924-0BB00-0AA0
	... for 2A modules (10 items)	Spring-loaded screw-type	6ES7 924-0BB00-1AB0 6ES7 924-0BB00-1AA0
	... for relays	Spring-loaded screw-type	6ES7 924-0CD00-0AB0 6ES7 924-0CD00-0AA0
Front connector	for 32-channel modules (refer to Figure 8-4)	Voltage supply via: Spring-loaded terminals	6ES7 921 3AA20-0AA0
	for 16-channel modules	Voltage supply via: spring-loaded screw-type	6ES7 921-3AA00-0AA0 6ES7 921-3AB00-0AA0
	for 16-channel 2A modules	Voltage supply via: spring-loaded screw-type	6ES7 921-3AC00-0AA0 6ES7 921-3AD00-0AA0
Connectors (plug-in connectors), set of 8 (insulation displacement connectors)			6ES7 921-3BE10-0AA0

Table 8-5 Components of SIMATIC TOP connect, continued

Components of SIMATIC TOP connect			Order number
Round-sheath ribbon cable 1x 16	Unshielded	30 m 60 m	6ES7 923-0CD00-0AA0 6ES7 923-0CG00-0AA0
	Shielded	30 m 60 m	6ES7 923-0CD00-0BA0 6ES7 923-0CG00-0BA0
Round-sheath ribbon cable 2 x 16	Unshielded	30 m 60 m	6ES7 923-2CD00-0AA0 6ES7 923-2CG00-0AA0
Crimping tool for 16-pin connector			6ES7 928-0AA00-0AA0

Selection aid

In the following table you will find the components of SIMATIC TOP connect with which you can wire the digital modules.

Table 8-6 Selection Table for SIMATIC TOP connect Components

Digital Modules	Terminal block for...				Front connector module for...	
	One-conductor connection	Three-conductor connection	2A modules	Relays	SM; 16 or 32 channels	2A modules
SM 321; DI 32 × 24 VDC	×	×	–	–	×	–
SM 321; DI 16 × 24 VDC	×	×	–	–	×	–
SM 321; DI 16 × 24 VDC; source input	×	×	–	–	×	–
SM 322; DO 32 × 24 VDC/0.5 V	×	×	–	×	×	–
SM 322; DO 16 × 24 VDC/0.5 V	×	×	–	×	×	–
SM 322; DO 8 × 24VDC/0.5 V; with diagnostic interrupt	×	×	–	–	×	–
SM 322; DO 8 × 24 VDC/2 A	–	–	×	–	–	×
SM 323; DI 16/DO 16 × 24VDC/ 0.5 A	×	×	–	–	×	–
SM 323; DI 8/DO 8 × 24 VDC/0.5 A	×	×	–	–	×	–

One-conductor or three-conductor connection

With the three-conductor connection, you can optionally apply the supply voltage for the module to the front connector module or to the terminal block. With the one-conductor connection, this can only be done to the front connector module.

2A module connection

You require the following information on wiring 2A modules only when you want to use the SM 322; 8 × DO 24 VDC/2 A with SIMATIC TOP connect.

8.3.2 Wiring the Module with Terminal Block for One-Conductor Connection

Connection Notes

Table 8-7 Connection Notes for SIMATIC TOP connect with One-Conductor Connection

Digital Modules	Connection Notes				
	Supply Voltage Feed-In			Additional jumper required at power supply	Description on terminal block not in line with description on SM
	At front connector only	Add. ground conn. at terminal block	At front connector or terminal block		
SM 321; DI 32 × 24 VDC	×	–	–	–	–
SM 321; DI 16 × 24 VDC	×	–	–	–	–
SM 321; DI 16 × 24 VDC; source input	×	–	–	–	–
SM 322; DO 32 × 24 VDC/0.5 A	×	–	–	–	–
SM 322; DO 16 × 24 VDC/0.5 A	×	–	–	–	–
SM 322; DO 8 × 24 VDC/0.5 A with diagnostic interrupt	×	–	–	–	×
SM 323; DI 16/DO 16 × DC 24 V/0.5 A	×	–	–	–	–
SM 323; DI 8/DO 8 × 24 VDC/0.5 A	×	–	–	–	–

Assignments of the terminal block for one-conductor connection

Table 8-8 Terminal Assignments of the Terminal Block for One-Conductor Connection

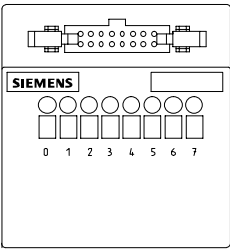
Front view of terminal block	Assignments of the Terminals
	Top row: Terminals 0 to 7: inputs/outputs x.0 to x.7

Connecting the power supply

Always connect the supply voltage to the front connector module. Observe the wiring rules in Table 8-3 on page 8-7.

In the following example, you must connect L+ to Plus of the **upper** terminal and M to Minus of the **lower** terminal.

Connecting the terminal block for one-conductor connection

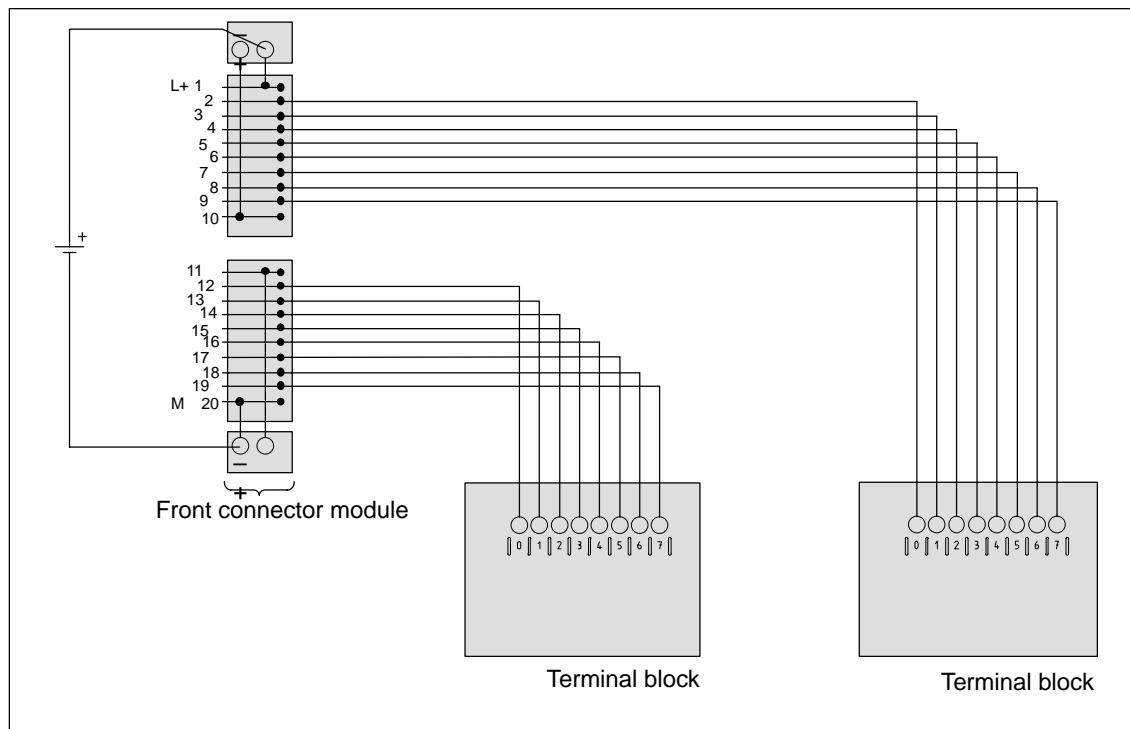

Figure 8-8 Wiring a Digital Module with Terminal Block for a One-Conductor Connection

8.3.3 Wiring the Module with Terminal Block for Three-Conductor Connection

Connection Notes

Table 8-9 Connection Notes for SIMATIC TOP connect with Three-Conductor Connection

Digital modules	Connection notes				
	Supply voltage feed-in			Additional jumper required at power supply	Description on terminal block not in line with description on SM
	At front connector only	Add. ground conn. at terminal block	At front connector or terminal block		
SM 321; DI 32 × 24 VDC	–	–	×	×	–
SM 321; DI 16 × 24 VDC	–	–	×	×	–
SM 321; DI 16 × 24 VDC; source input	–	–	×	×	–
SM 322; DO 32 × 24 VDC/0.5 A	–	–	×	–	–
SM 322; DO 16 × 24 VDC/0.5 A	–	–	×	–	–
SM 322; DO 8 × 24 VDC/0.5 A with diagnostic interrupt	–	–	×	×	×
SM 323; DI 16/DO 16 × 24 VDC/0.5 A	–	–	×	–	–
SM 323; DI 8/DO 8 × 24 VDC/0.5 A	–	–	×	–	–

Assignment of the terminal block for three-conductor connection

Table 8-10 Terminal Assignments of the Terminal Block for Three-Conductor Connection

Front view of terminal block	Assignments of the Terminals
	Top row: Terminals 0 to 7: inputs/outputs x.0 to x.7
	Center row: All terminals: M potential
	Bottom row: All terminals: L + potential

Connecting the power supply

Observe the wiring rules in Table 8-3 on page 8-7.

With some digital modules, two jumpers are generally required for connecting the supply voltage (refer to Table 8-9 on page 8-16).

You can wire the jumpers either in the front connector or in the terminal block. Irrespective of this, you must interconnect the two Plus terminals and the two Minus terminals.

Connecting the terminal block for three-conductor connection

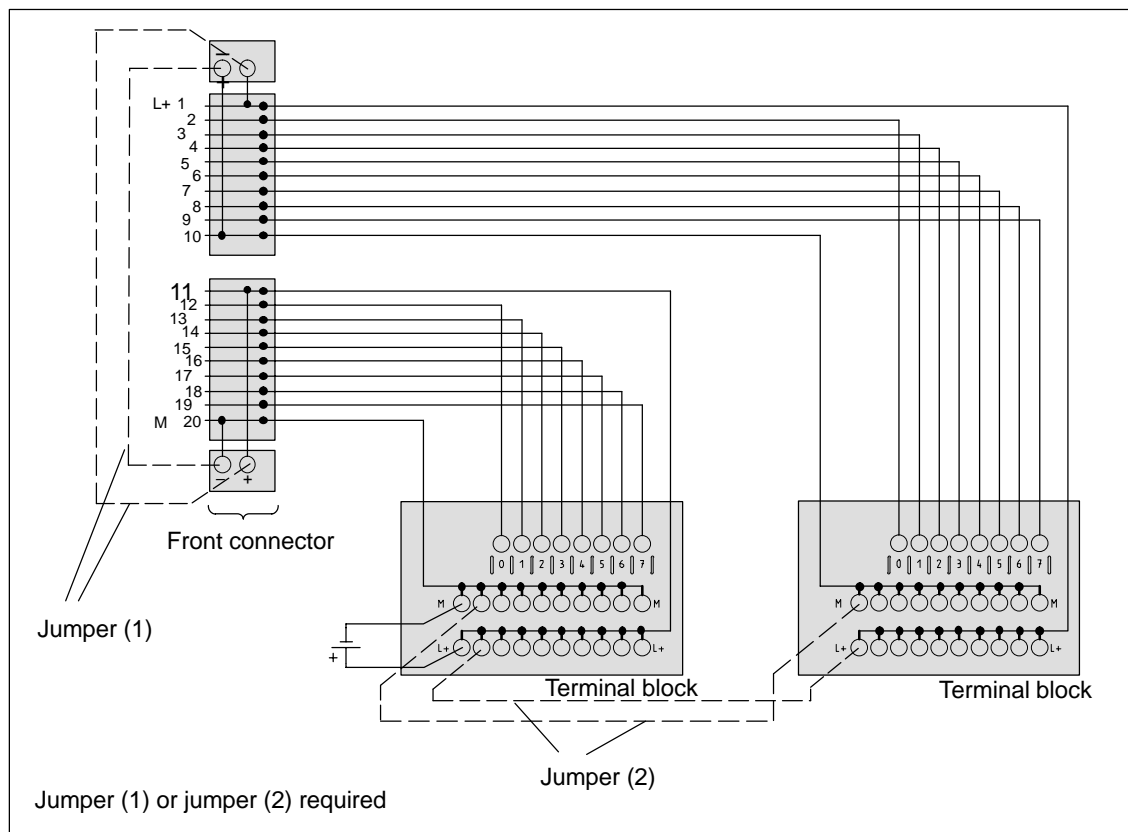

Figure 8-9 Wiring a Digital Module with Terminal Block for a Three-Conductor Connection

8.3.4 Wiring the Module with Terminal Block for 2A Modules

You can use the terminal block for 2A modules to wire the SM 322;
8 × DO 24 VDC/2A.

Connection Notes

Table 8-11 Connection Notes for SIMATIC TOP connect with 2A Module Connection

Digital Modules	Connection Notes				
	Supply Voltage Feed-In			Add. jumper required for power supply	Descr. on terminal block not in line with descr. on SM
	At front connector only	Add. ground conn. at terminal block	At front connector or terminal block		
SM 322; DO 16 × 24 VDC/2 A	×	×	–	–	–

Assignment of the terminal block for connection of 2A modules

Table 8-12 Terminal Assignments of the Terminal Block for 2A Modules

Front View of Terminal Block	Assignments of the Terminals (left)	Assignments of the Terminals (right)
	Top row: Terminals 0 to 3: outputs x.0 to x.3	Top row, on right: Terminals 0 to 3: outputs x.4 to x.7
	Center row: Terminals 0 to 3: potential M1 for x.0 to x.3	Center row, on right: Terminals 0 to 3: potential M2 for x.4 to x.7
	Bottom row: two-terminal connection for M1	Bottom row: two-terminal connection for M2

Connecting the power supply

Please observe the following when connecting the power supply:

- Apply the wiring rules in Table 8-3 on page 8-7.
- Connect the supply voltage at the front connector module to the potential terminals using separate cables.
- You must equip each terminal block with a cable for M1 or M2, in addition to the connecting cable.
- Connect M1 or M2 via a separate line with the front connector and the terminal block. You may jumper the potential of M1 and M2.

Connection to terminal block for 2A modules

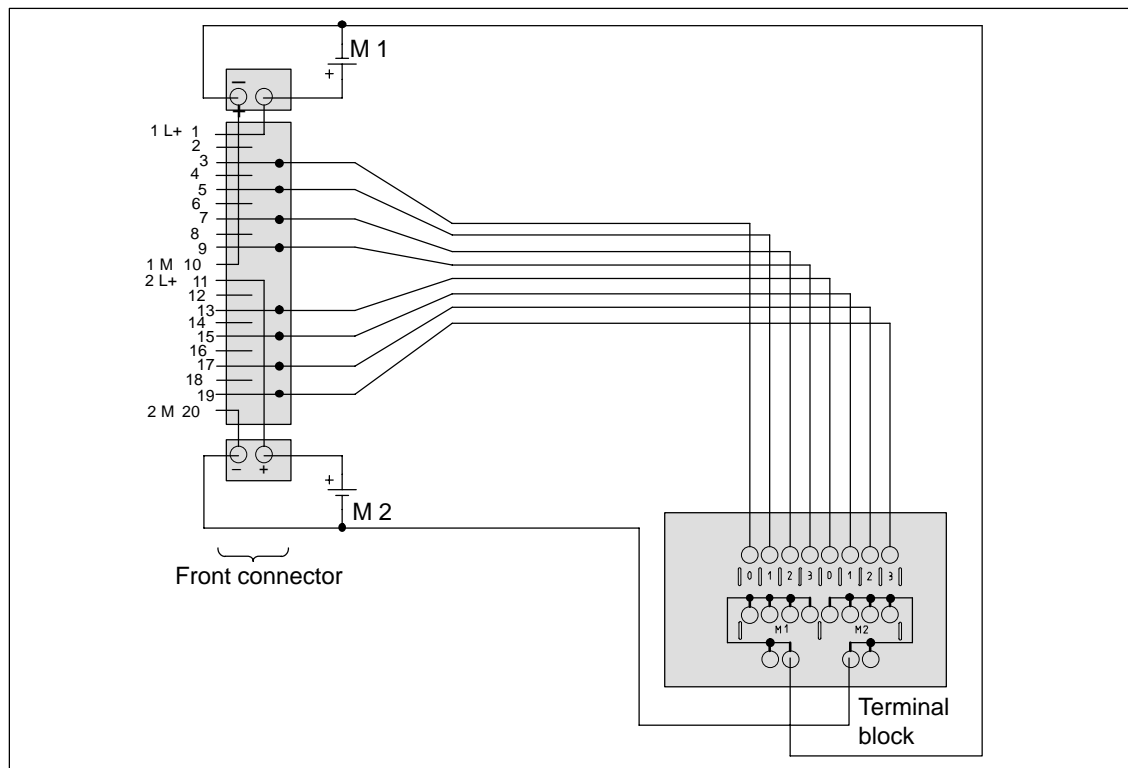

Figure 8-10 Wiring with Terminal Block for 2A Module

8.4 Wiring SIMATIC TOP connect TPA with Analog Modules

Introduction

For wiring the module with actuators/sensors using SIMATIC TOP connect TPA, you must first select the components as a function of the method of connection (screw-type or spring-loaded terminal).

8.4.1 SIMATIC TOP connect TPA Components and Selection Aid

Components

The following table contains all the component of SIMATIC TOP connect TPA.

Table 8-13 Components for SIMATIC TOP connect TPA

Components of SIMATIC TOP connect TPA		Order number
Terminal block	Quantity: 1	Spring-loaded terminals Screw-type terminals
	Quantity: 10	Spring-loaded terminals Screw-type terminals
Front connector	Voltage supply via: Spring-loaded terminals Screw-type terminals	6ES7 921-3AF00-0AA0 6ES7 921-3AG00-0AA0
Connectors (plug-in connectors), set of 8 (insulation displacement connectors)		6ES7 921-3BE10-0AA0
Shielding plate for terminal block, set of 4		6ES7 928-1BA00-0AA0
Terminal element for: 2 cables, each with a shield diameter of 2 to 6 mm 1 cable with a shield diameter of 3 to 8 mm 1 cable with a shield diameter of 4 to 13 mm		6ES7 390-5AB00-0AA0 6ES7 390-5BA00-0AA0 6ES7 390-5CA00-0AA0
Round-sheath ribbon cable, shielded Ø 8 mm	30 m	6ES7 923-0CD00-0BA0
	60 m	6ES7 923-0CG00-0BA0
Crimping tool for 16-pin connector		6ES7 928-0AA00-0AA0

8.4.2 SIMATIC TOP connect TPA Terminal Assignment and Terminal Allocation

Terminal marking

On the TPA terminal block, the terminals are identified by letters. This simplifies the allocation of the terminals on the analog module to the terminals on the terminal block.

Terminal block assignment

Table 8-14 Terminal Assignment of the Terminal Block of SIMATIC TOP connect TPA

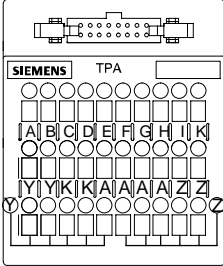
Front view of terminal block	Assignments of the Terminals
	<p>Terminals $\text{\textcircled{Z}}$ and $\text{\textcircled{Y}}$ can be used for multiplying arbitrary potentials and signals.</p> <hr/> <p>The terminals having identical letters are electrically interconnected, with the exception of terminals $\text{\textcircled{Z}}$ and Z, and also $\text{\textcircled{Y}}$ and Y.</p>

Multiplier terminal

The lower tier of terminals on the terminal block is designed as 2 × 5 multiplier terminals.

Terminal allocation of an analog module to SIMATIC TOP connect TPA

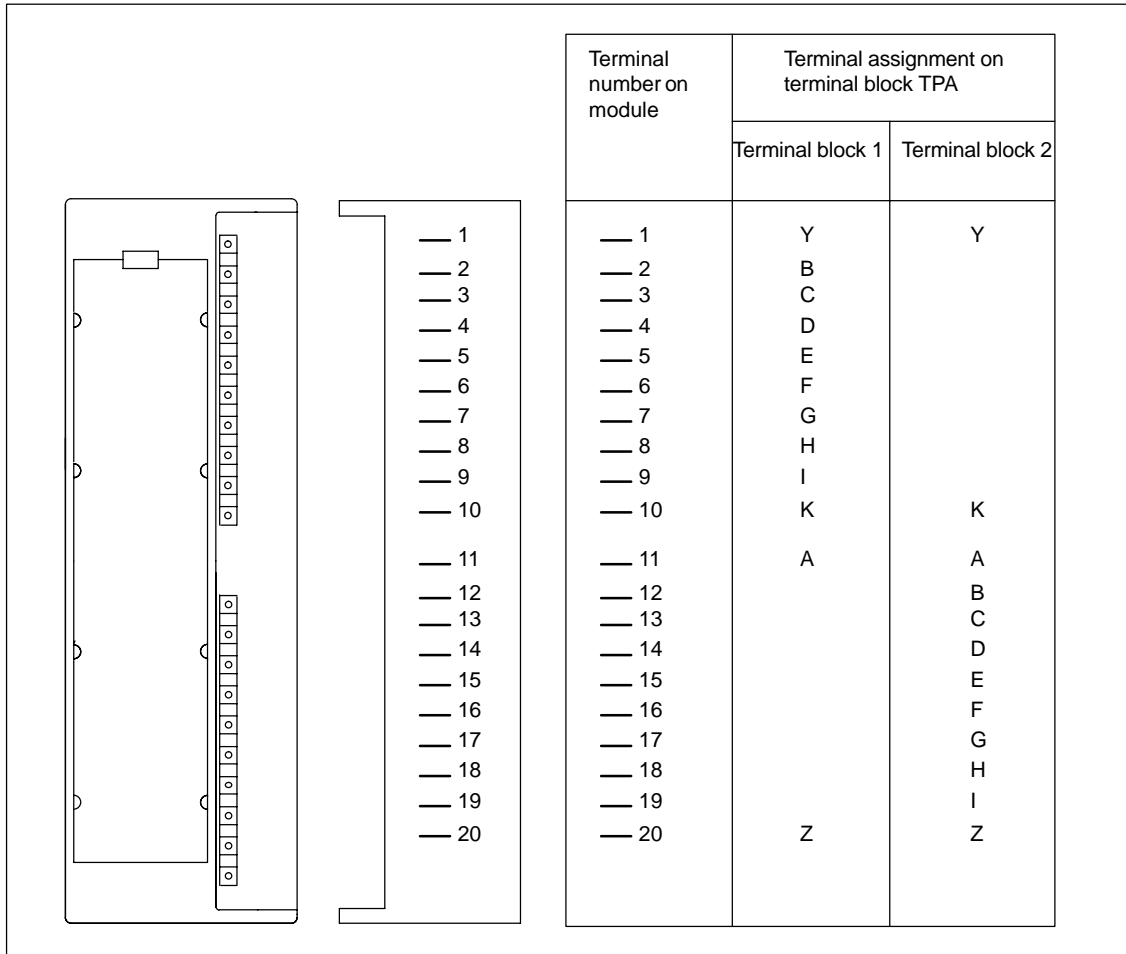

Figure 8-11 Terminal Assignment of Analog Module to SIMATIC TOP connect TPA

8.4.3 Connecting the Signal-Line Shield

Two options for connecting the shield

You can connect the signal line shield to ground as follows:

- On the analog module by means of a shield-support element
(refer to the manual *Hardware and Installation for the S7-300* or the manual *Distributed I/O device ET 200M* in the section on wiring)
- Directly to the terminal block by means of a shielding plate

Connecting the shield to the terminal block using a shielding plate

1. Before mounting, attach a shielding plate to the terminal block.
2. Mount the terminal block on the DIN rail.
(In the figure below, you can see that the shielding plate is applied to the rear of the terminal block and thus there is a connection to the grounded rail.)
3. Place the signal-line shield with the shield terminals on the shielding plate.

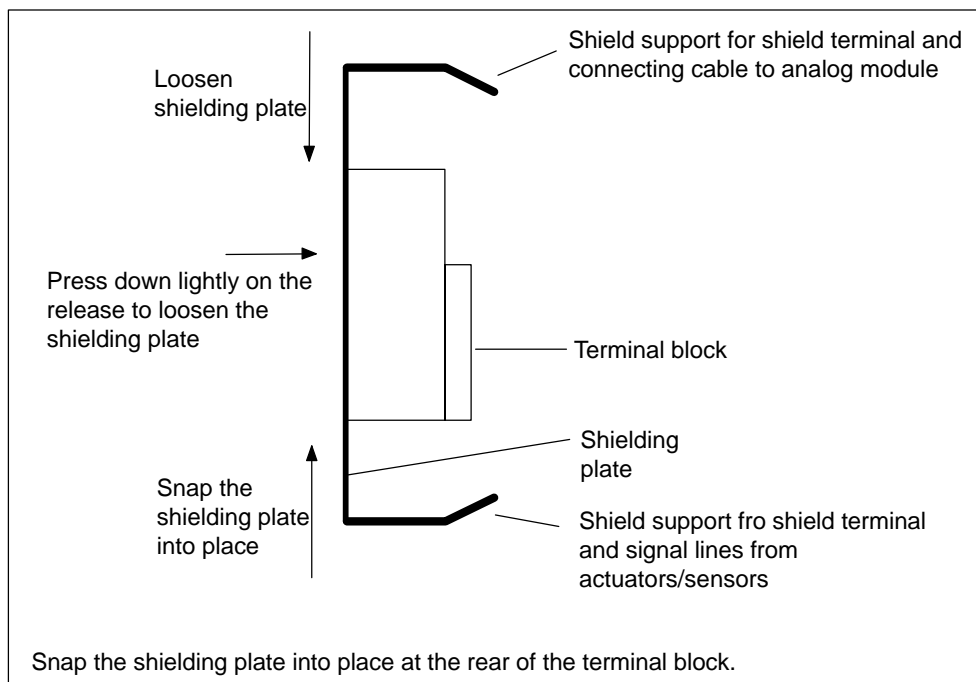

Figure 8-12 SIMATIC TOP connect TPA Terminal Block with Shielding Plate

8.4.4 Connection Example

Connecting the load voltage supply

You can connect the load voltage supply of the analog module to the front connector module. There are separate terminals on the front connector module for the load voltage L+ and M. Observe the wiring rules in Table 8-3 on page 8-7.

Allocation of front connector to terminal block

The **upper socket** of the front connector module is the connection for **terminal block 1** and the **lower socket** of the front connector module is the connection for **terminal block 2**.

Connection example

The illustration below shows an example of connecting the analog input module SM 321; AI 8 × 12 bits in "Resistance Test" mode.

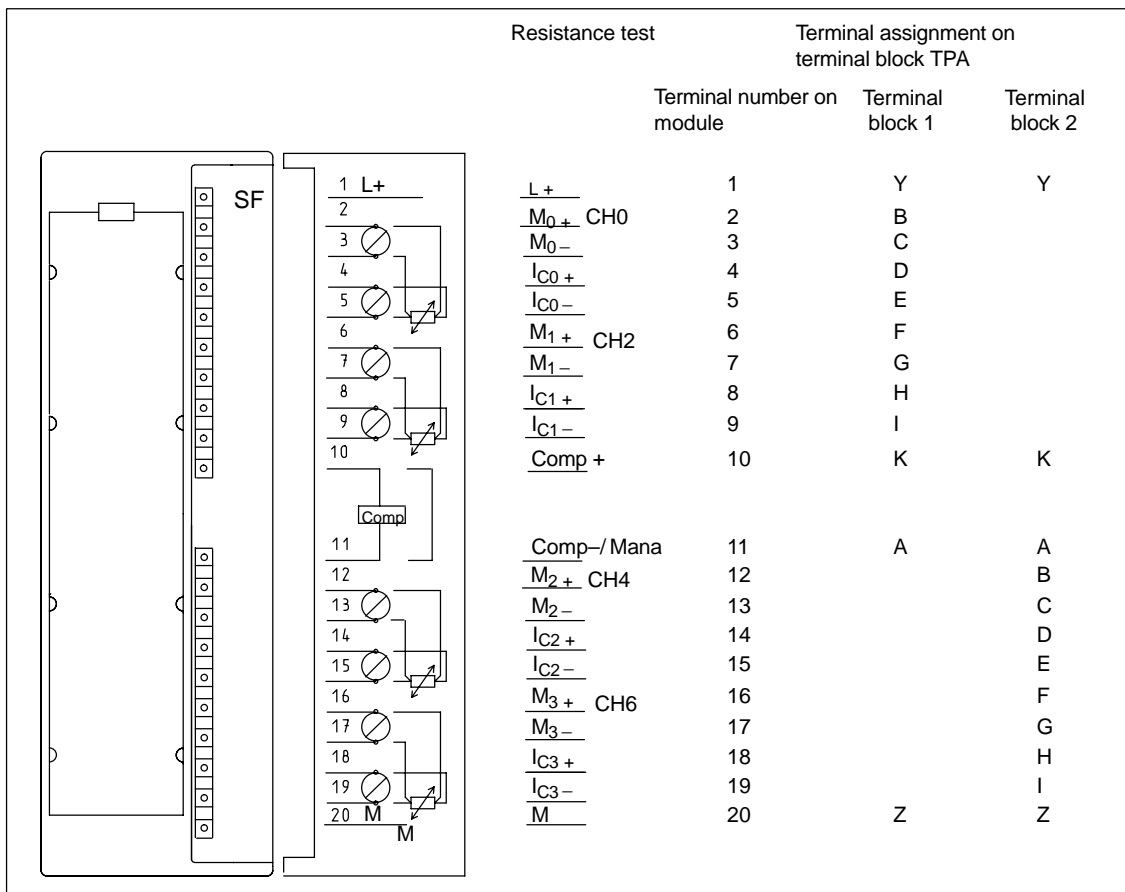

Figure 8-13 Example of Connecting SIMATIC TOP connect TPA to SM 321; AI 8 × 12 bits

Parameter Sets for Signal Modules

A

In this chapter

Section	Contents	Page
A.1	How to Assign the Parameters for Signal Modules in the User Program	A-1
A.2	Parameters of the Digital Input Modules	A-3
A.3	Parameters of the Digital Output Modules	A-5
A.4	Parameters of the Analog Input Modules	A-7
A.5	Parameters of the SM 331; AI 8 × RTD	A-11
A.6	Parameters der SM 331; AI 8 × TC	A-19
A.7	Parameters of the SM 331; AI 8 × 13 bits	A-27
A.8	Parameters of the SM 331; AI 8 × 16 bits	A-29
A.9	Parameters of the Analog Output Modules	A-35
A.10	Parameters of the SM 332; AO 8 × 12 bits	A-38
A.11	Parameters of the Analog Input/Output Modules	A-40

A.1 How to Assign the Parameters for Signal Modules in the User Program

Parameter assignment in the user program

You have already assigned parameters to the modules in *STEP 7*.

In the user program, you can use a SFC:

- To reassign parameters to the module and
- To transfer the parameters from the CPU to the addressed signal module

Parameters stored in data records

The parameters of the signal modules are located in data records 0 and 1; for some other analog input modules, in data record 128 as well.

Modifiable parameters

You can change the parameters of record 1 and pass them to the signal module using SFC 55. The parameters set on the CPU are not changed when you do this!

You cannot modify the parameters of data record 0 in the user program.

SFCs for parameter assignment

The following SFCs are available for assigning parameters to the signal modules in the user program:

Table A-1 SFCs for Assigning Parameters to Signal Modules

SFC No.	Identifier	Application
55	WR_PARM	Transfer modifiable parameters (data record 1 and 28) to the addressed signal module.
56	WR_DPARM	Transfer parameters (data record 0, 1 or 128) from the CPU to the addressed signal module.
57	PARM_MOD	Transfer all parameters (data record 0, 1 and 128) from the CPU to the addressed signal module.

Description of the parameters

The following sections contain **all** the modifiable parameters for the various module classes. The parameters of the signal modules are described:

- In the on-line help of *STEP 7*
- In this reference manual

You will find the parameters that can be adjusted for the signal module concerned in the specific sections for the different signal modules.

Further references

An in-depth description of the principle of assigning parameters to signal modules in the user program and a description of the SFCs that can be used for that purpose will be found in the *STEP 7* manuals.

A.2 Parameters of the Digital Input Modules

Parameters

The table below contains all the parameters you can set for digital input modules. You will see which parameters you can modify from the list:

- In *STEP 7*
- With SFC 55 "WR_PARM"

The parameters set with *STEP 7* can also be transferred with SFCs 56 and 57 to the module (refer to the *STEP 7* manuals).

Table A-2 Parameters of the Digital Input Modules

Parameter	Data Record No.	Parameters can be assigned with ...	
		... SFC 55	... Programming Device
Input delay	0	No	Yes
Diagnostics		No	Yes
Hardware interrupt enable	1	Yes	Yes
Diagnostics interrupt enable		Yes	Yes
Hardware interrupt with rising edge		Yes	Yes
Hardware interrupt with falling edge		Yes	Yes

Note

If you want to enable the diagnostic interrupt in the user program in data record 1, you must enable the diagnosis in data record 0 beforehand using *STEP 7*.

Data record 1 structure

The figure below shows the structure of data record 1 for the parameters of the digital input modules.

You activate a parameter by setting the corresponding bit to "1".

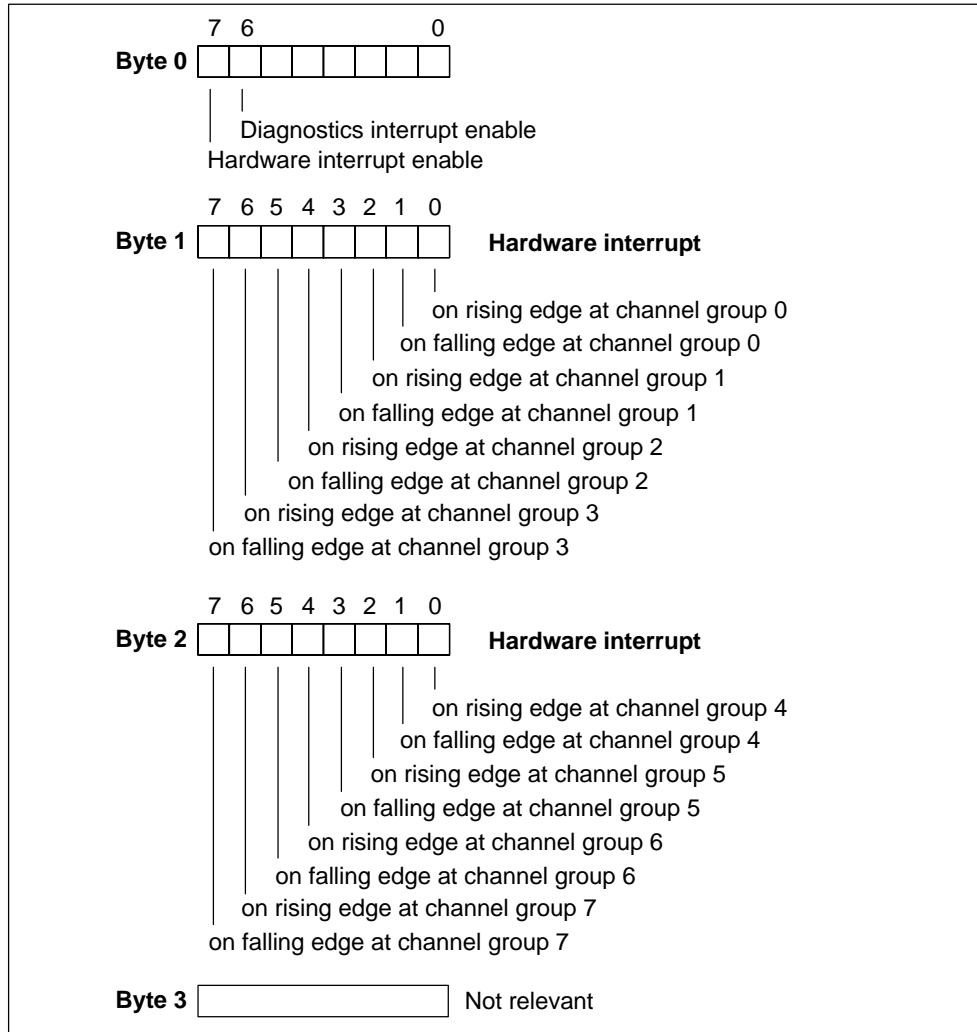

Figure A-1 Data Record 1 for Parameters of the Digital Input Modules

A.3 Parameters of the Digital Output Modules

Parameters

The table below contains all the parameters you can set for digital output modules. You will see which parameters you can modify from the list:

- In *STEP 7*
- With SFC 55 "WR_PARM"

The parameters set with *STEP 7* can also be transferred with SFCs 56 and 57 to the module (refer to the *STEP 7* manuals).

Table A-3 Parameters of the Digital Output Modules

Parameter	Data Record No.	Parameters can be assigned with ...	
		... SFC 55	... Programming Device
Diagnostics	0	No	Yes
Diagnostics interrupt enable	1	Yes	Yes
Behavior on CPU STOP		Yes	Yes
Enable substitute value "1"		Yes	Yes

Note

If you want to enable the diagnostic interrupt in the user program in data record 1, you must enable the diagnosis in data record 0 beforehand using *STEP 7*.

Data record 1 structure

The figure below shows the structure of data record 1 for the parameters of the digital output modules.

You activate a parameter by setting the corresponding bit in byte 0 to "1".

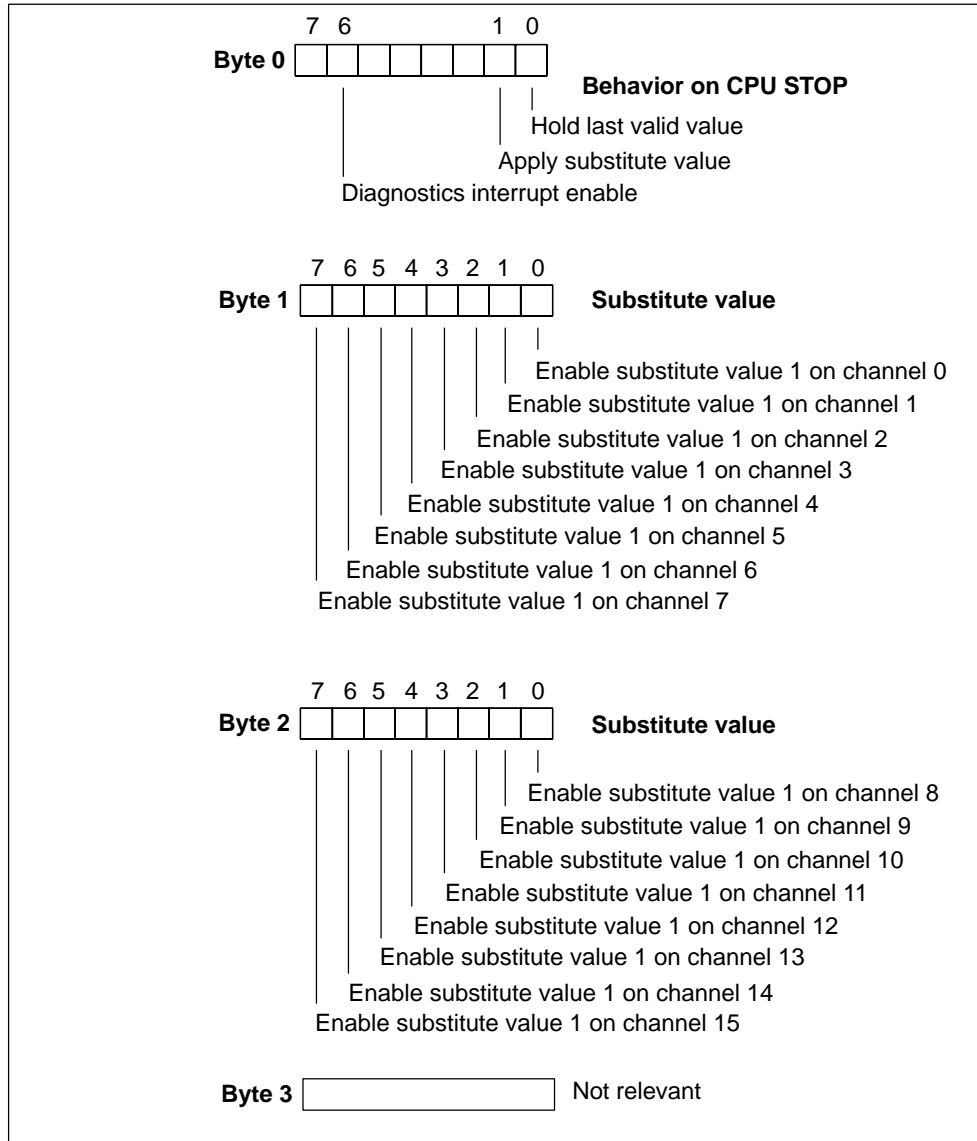

Figure A-2 Data Record 1 for Parameters of the Digital Output Modules

Note

You should only enable the parameters in byte 0, "Hold last valid value" and "Enable substitute value" as an alternative.

A.4 Parameters of the Analog Input Modules

Parameters

The table below contains all the parameters you can set for analog input modules. You will see which parameters you can modify from the list:

- In *STEP 7*
- With SFC 55 "WR_PARM"

The parameters set with *STEP 7* can also be transferred with SFCs 56 and 57 to the module (refer to the *STEP 7* manuals).

Table A-4 Parameters of the Analog Input Modules

Parameter	Data Record No.	Parameters can be assigned with ...	
		... SFC 55	... Programming Device
Diagnostics: Group diagnostics	0	No	Yes
Diagnostics: With wire-break check		No	Yes
Temperature unit		No	Yes
Temperature coefficient		No	Yes
Smoothing		No	Yes
Diagnostics interrupt enable	1	Yes	Yes
Limit value interrupt enable		Yes	Yes
Cycle end interrupt enable		Yes	Yes
Interference suppression		Yes	Yes
Measuring method		Yes	Yes
Measuring range		Yes	Yes
Upper limit value		Yes	Yes
Lower limit value		Yes	Yes

Note

If you want to enable the diagnostic interrupt in the user program in data record 1, you must enable the diagnosis in data record 0 beforehand using *STEP 7*.

Data record 1 structure

The figure below shows the structure of data record 1 for the parameters of the analog input modules.

You activate a parameter by setting the corresponding bit in byte 0 and 1 to "1".

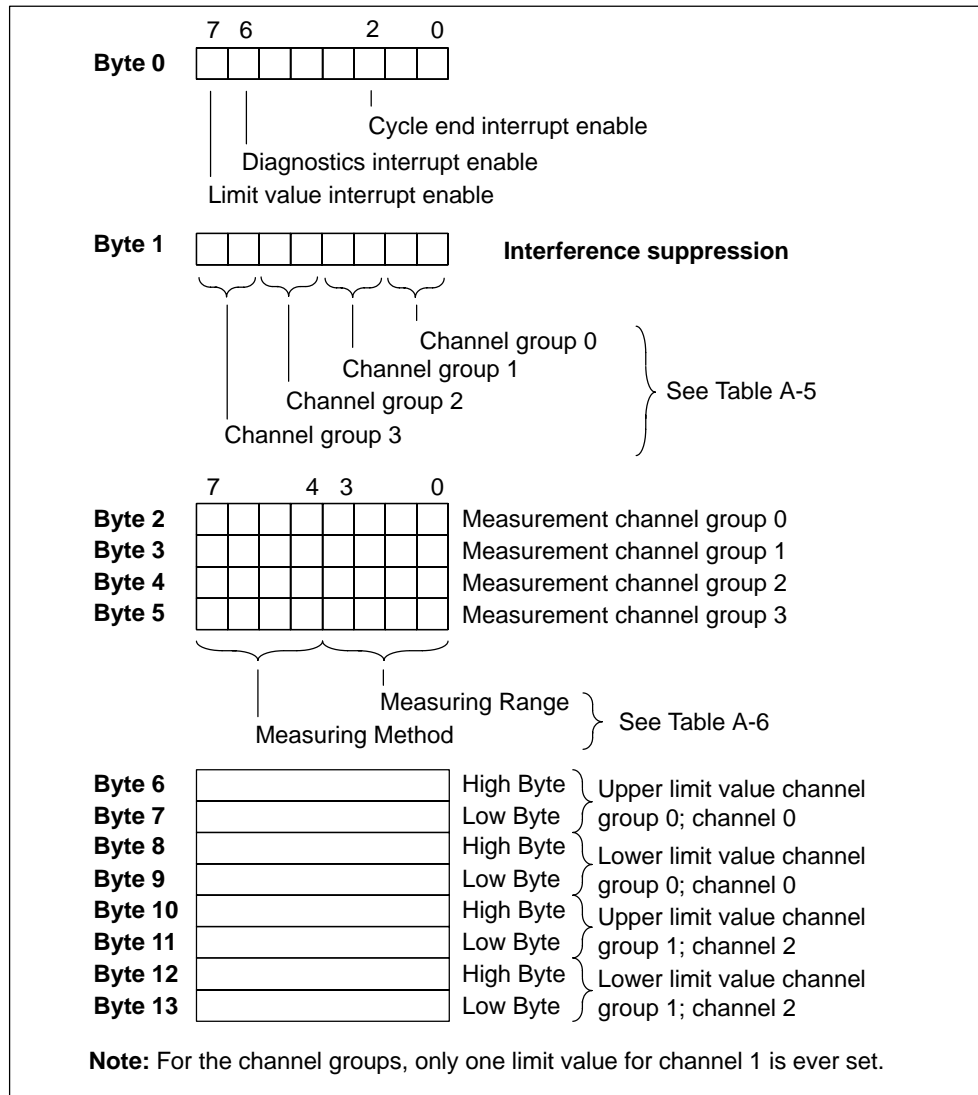

Figure A-3 Data Record 1 for Parameters of the Analog Input Modules

Note

The representation of the limit values matches the analog value representation (see Chapter 4). Please observe the range limits when setting the limit values.

Interference frequency suppression

The table below contains the codes for the different frequencies, which you enter in byte 1 of data record 1 (refer to Figure A-3). You must count the resulting integration time separately for each channel!

Table A-5 Codes for Interference Suppression of the Analog Input Modules

Interference Suppression	Integration Time	Code
400 Hz	2.5 ms	2#00
60 Hz	16.7 ms	2#01
50 Hz	20 ms	2#10
10 Hz	100 ms	2#11

Measuring methods and measuring ranges

The table below contains all the measuring methods and measuring ranges of the analog input modules and their codes. You must enter these codes in bytes 2 to 5 of data record 1 (refer to Figure A-3).

Note

Please note that a measuring range module may need to be reconnected, depending on the measuring range (see Chapter 4)!

Table A-6 Codes for the Measuring Ranges of the Analog Input Modules

Measuring Method	Code	Measuring Range	Code
Deactivated	2#0000	Deactivated	2#0000
Voltage	2#0001	± 80 mV ± 250 mV ± 500 mV ± 1 V ± 2.5 V ± 5 V 1 to 5 V 0 to 10 V ± 10 V ± 25 mV ± 50 mV	2#0001 2#0010 2#0011 2#0100 2#0101 2#0110 2#0111 2#1000 2#1001 2#1010 2#1011

Table A-6 Codes for the Measuring Ranges of the Analog Input Modules

Measuring Method	Code	Measuring Range	Code
Four-wire transmitter	2#0010	± 3.2 mA ± 10 mA 0 to 20 mA 4 to 20 mA ± 20 mA ± 5 mA	2#0000 2#0001 2#0010 2#0011 2#0100 2#0101
Two-wire transmitter	2#0011	4 to 20 mA	2#0011
Resistance, four-conductor connection	2#0100	150 Ω 300 Ω 600 Ω 10 kΩ	2#0010 2#0100 2#0110 2#1001
Resistor four-conductor connection; 100 Ω compensation	2#0110	52 to 148 Ω 250 Ω 400 Ω 700 Ω	2#0001 2#0011 2#0101 2#0111
Thermal resistance + linearization four-conductor connection	2#1000	Pt 100 climate Ni 100 climate Pt 100 standard range Pt 200 standard range Pt 500 standard range Pt 1000 standard range Ni 1000 standard range Pt 200 climate Pt 500 climate Pt 1000 climate Ni 1000 climate Ni 100 standard range	2#0000 2#0001 2#0010 2#0011 2#0100 2#0101 2#0110 2#0111 2#1000 2#1001 2#1001 2#1001 2#1011
Thermocouples internal comparison	2#1010	Type B [PtRh – PtRh] Type N [NiCrSi – NiSi]	2#0000 2#0001
Thermocouples external comparison	2#1011	Type E [NiCr – CuNi] Type R [PtRh –Pt] Type S [PtRh –Pt] Type J [Fe – CuNi IEC]	2#0010 2#0011 2#0100 2#0101
Thermocouples + linearization internal comparison	2#1101	Type L [Fe – CuNi] Type T [Cu – CuNi] Type K [NiCr – Ni]	2#0110 2#0111 2#1000
Thermocouples + linearization external comparison	2#1110	Type U [Cu –Cu Ni]	2#1001

A.5 Parameters of the SM 331; AI 8 × RTD

Parameters

The table below contains all the parameters which you can set for analog input module SM 331; AI 8 × RTD.

You will see which parameters you can modify from the list:

- In *STEP 7*
- With SFC 55 "WR_PARM"

The parameters set with *STEP 7* can also be transferred with SFCs 56 and 57 to the module (refer to the *STEP 7* manuals).

Table A-7 Parameters of the SM 331; AI 8 × RTD

Parameter	Data Record No.	Parameters can be assigned with ...	
		... SFC 55	... Programming Device
Diagnostics: Group diagnostics	0	No	Yes
Diagnostics: With wire-break check		No	Yes
Diagnostics interrupt enable	1	Yes	Yes
Limit value interrupt enable		Yes	Yes
Cycle end interrupt enable		Yes	Yes
Temperature unit		Yes	Yes
Measuring method	128	Yes	Yes
Measuring range		Yes	Yes
Module filtering mode		Yes	Yes
Temperature coefficient		Yes	Yes
Interference suppression		Yes	Yes
Smoothing		Yes	Yes
Upper limit value		Yes	Yes
Lower limit value		Yes	Yes

Note

If you want to enable the diagnostic interrupt in the user program in data record 1, you must enable the diagnosis in data record 0 beforehand using *STEP 7*.

Structure of data record 1

The figure below shows the structure of data record 1 for SM 331; AI 8 × RTD. You activate a parameter by setting the corresponding bit to "1".

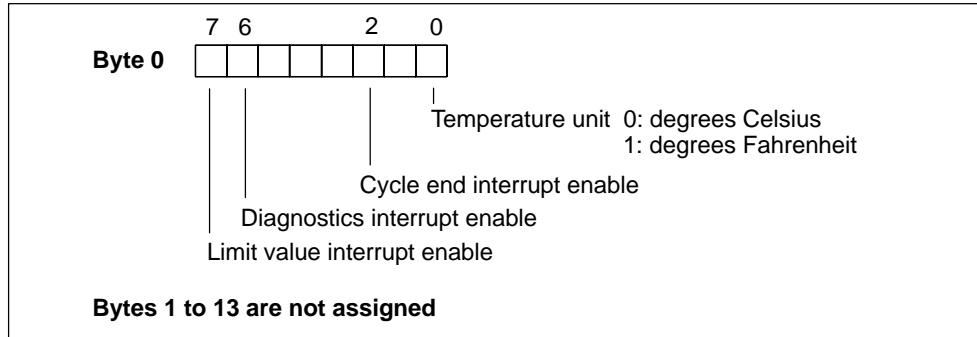

Figure A-4 Data Record 1 of the Parameters for SM 331; AI 8 × RTD

Structure of data record 128

The figure below shows the structure of data record 128 for SM 331; AI 8 × RTD.

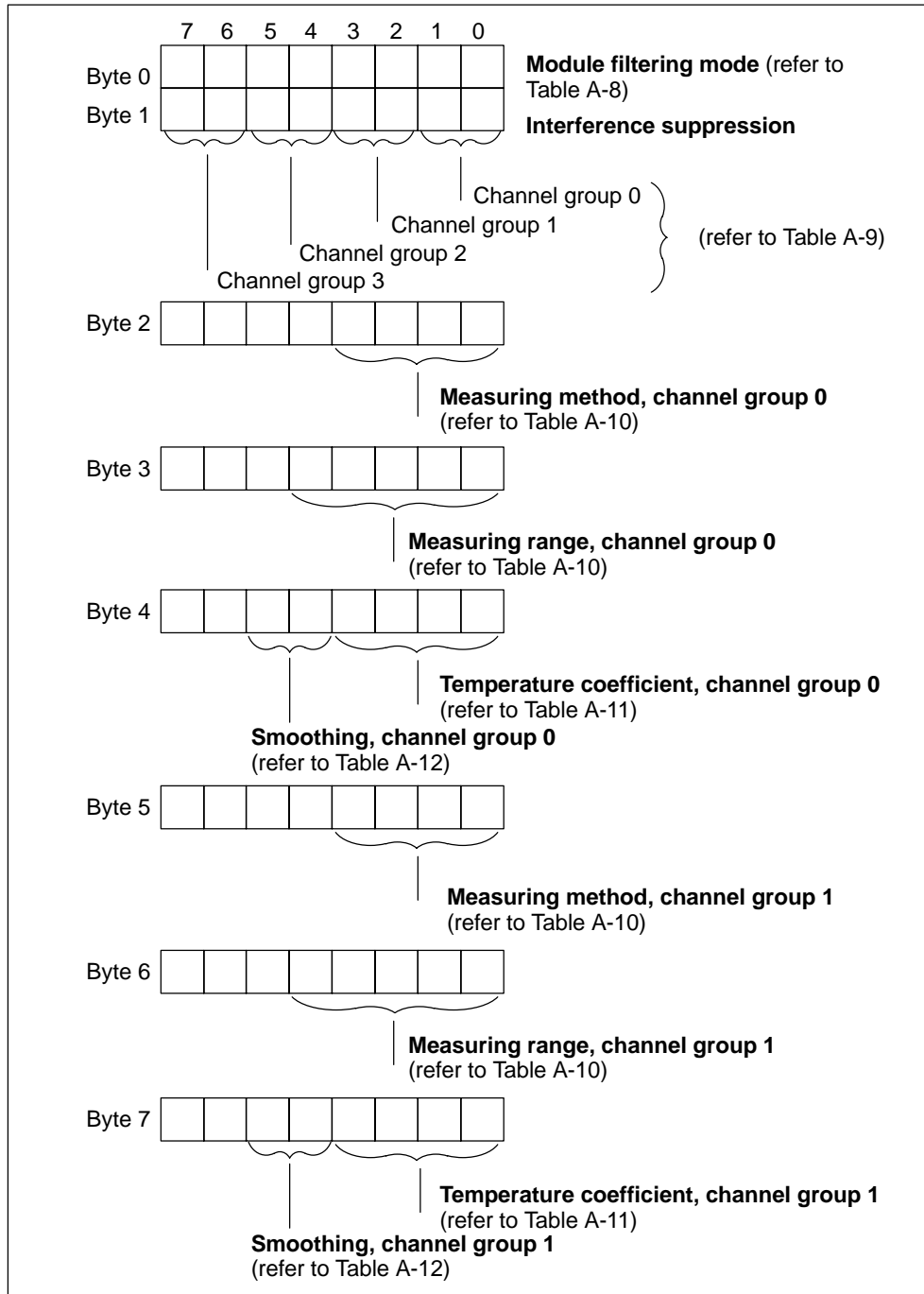

Figure A-5 Data Record 128 of the Parameters for SM 331; AI 8 × RTD

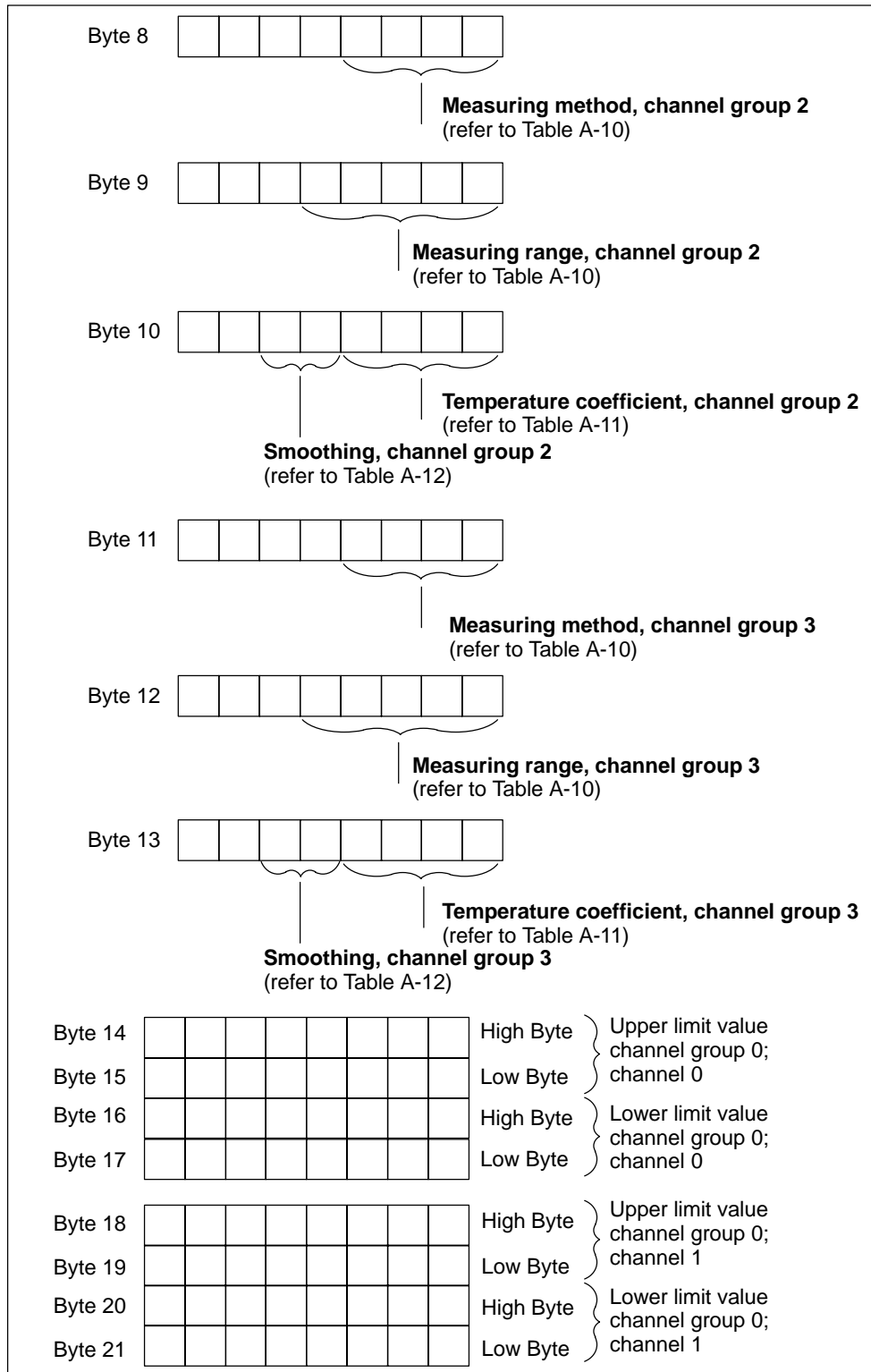

Figure A-6 Data Record 128 of the SM 331; AI 8 x RTD (Continued)

Byte 22								High Byte	} Upper limit value channel group 1; channel 2
Byte 23								Low Byte	
Byte 24								High Byte	} Lower limit value channel group 1; channel 2
Byte 25								Low Byte	
Byte 26								High Byte	} Upper limit value channel group 1; channel 3
Byte 27								Low Byte	
Byte 28								High Byte	} Lower limit value channel group 1; channel 3
Byte 29								Low Byte	
Byte 30								High Byte	} Upper limit value channel group 2; channel 4
Byte 31								Low Byte	
Byte 32								High Byte	} Lower limit value channel group 2; channel 4
Byte 33								Low Byte	
Byte 34								High Byte	} Upper limit value channel group 2 channel 5
Byte 35								Low Byte	
Byte 36								High Byte	} Lower limit value channel group 2; channel 5
Byte 37								Low Byte	
Byte 38								High Byte	} Upper limit value channel group 3; channel 6
Byte 39								Low Byte	
Byte 40								High Byte	} Lower limit value channel group 3; channel 6
Byte 41								Low Byte	
Byte 42								High Byte	} Upper limit value channel group 3; channel 7
Byte 43								Low Byte	
Byte 44								High Byte	} Lower limit value channel group 3; channel 7
Byte 45								Low Byte	

Figure A-7 Data Record 128 of the SM 331; AI 8×RTD (Continued)

Note

The representation of the limit values matches the analog value representation (see Chapter 4). Please observe the range limits when setting the limit values.

Operating modes of the SM 331; AI 8 × RTD

The table below contains the codes for the different operating modes, which you enter in byte 0 of data record 128 (refer to Figure A-5).

Table A-8 Codes of Operating Modes of the SM 331; AI 8 × RTD

Module filtering mode	Code
8 channels hardware filter	2#00000000
8 channels software filter	2#00000001
4 channels hardware filter	2#00000010

Interference frequency suppression of the SM 331; AI 8 × RTD

The table below contains the codes for the different frequencies, which you enter in byte 1 of data record 128 (refer to Figure A-5). Note that the settings 50 Hz, 60 Hz and 400 Hz only apply to 8-channel software filter mode. The setting 50, 60 and 400 Hz only applies to 8-channel and 4-channel hardware filter mode.

Table A-9 Interference Frequency Suppression Codes for SM 331; AI 8 × RTD

Interference Suppression	Code
400 Hz	2#00
60 Hz	2#01
50 Hz	2#10
50/60/400 Hz	2#11

Measuring methods and measuring ranges of the SM 331; AI 8 × RTD

The table below contains all the measuring methods and measuring ranges of the module and its codes. You must enter these codes in the corresponding bytes of data record 128 (refer to Figure A-3).

Table A-10 Codes for the Measuring Ranges of the SM 331; AI 8 × RTD

Measuring Method	Code	Measuring Range	Code
Deactivated	2#0000	Deactivated	2#0000
Resistance, four-conductor connection	2#0100	150 Ω	2#0010
		300 Ω	2#0100
		600 Ω	2#0110
Resistance, three-conductor connection	2#0101	150 Ω	2#0010
		300 Ω	2#0100
		600 Ω	2#0110

Table A-10 Codes for the Measuring Ranges of the SM 331; AI 8 × RTD

Measuring Method	Code	Measuring Range	Code
Thermal resistance + linearization four-conductor connection	2#1000	Pt 100 climate	2#00000000
		Ni 100 climate	2#00000001
		Pt 100 standard	2#00000010
		Ni 100 standard	2#00000011
		Pt 500 standard	2#00000100
		Pt 1000 standard	2#00000101
		Ni 1000 standard	2#00000110
		Pt 200 climate	2#00000111
		Pt 500 climate	2#00001000
		Pt 1000 climate	2#00001001
		Ni 1000 climate	2#00001010
		Pt 200 standard	2#00001011
		Ni 120 standard	2#00001100
		Ni 120 climate	2#00001101
		Cu 10 climate	2#00001110
		Cu 10 standard	2#00001111
		Ni 200 standard	2#00010000
		Ni 200 climate	2#00010001
		Ni 500 standard	2#00010010
		Ni 500 climate	2#00010011
Thermal resistance + linearization three-conductor connection	2#1001	Pt 100 climate	2#00000000
		Ni 100 climate	2#00000001
		Pt 100 standard	2#00000010
		Ni 100 standard	2#00000011
		Pt 500 standard	2#00000100
		Pt 1000 standard	2#00000101
		Ni 1000 standard	2#00000110
		Pt 200 climate	2#00000111
		Pt 500 climate	2#00001000
		Pt 1000 climate	2#00001001
		Ni 1000 climate	2#00001010
		Pt 200 standard	2#00001011
		Ni 120 standard	2#00001100
		Ni 120 climate	2#00001101
		Cu 10 climate	2#00001110
		Cu 10 standard	2#00001111
		Ni 200 standard	2#00010000
		Ni 200 climate	2#00010001
		Ni 500 standard	2#00010010
		Ni 500 climate	2#00010011

Temperature coefficient of the SM 331; AI 8 × RTD

The table below contains the codes for the temperature coefficient which you enter in the corresponding byte of data record 128 (refer to Figure A-5).

Table A-11 Codes of Temperature Coefficients of the SM 331; AI 8 × RTD

Temperature coefficient	Code
Pt0.003850 $\Omega/\Omega/^\circ\text{C}$ (IPTS-68)	2#0000
Pt0.003916 $\Omega/\Omega/^\circ\text{C}$	2#0001
Pt0.003902 $\Omega/\Omega/^\circ\text{C}$	2#0010
Pt0.003920 $\Omega/\Omega/^\circ\text{C}$	2#0011
Pt0.003850 $\Omega/\Omega/^\circ\text{C}$ (ITS-90)	2#0100
Ni 0.006180 $\Omega/\Omega/^\circ\text{C}$	2#1000
Ni 0.006720 $\Omega/\Omega/^\circ\text{C}$	2#1001
Cu0.00427 $\Omega/\Omega/^\circ\text{C}$	2#1100

Smoothing of the SM 331; AI 8 × RTD

The table below contains the codes for all smoothing modes, which you enter in the corresponding byte of data record 128 (refer to Figure A-5).

Table A-12 Codes Smoothing of the SM 331; AI 8 × RTD

Smoothing	Code
None	2#00
Low	2#01
Average	2#10
High	2#11

A.6 Parameters der SM 331; AI 8 × TC

Parameters

The table below contains all the parameters which you can set for analog input module SM 331; AI 8 × TC.

You will see which parameters you can modify from the list:

- In *STEP 7*
- With SFC 55 "WR_PARM"

The parameters set with *STEP 7* can also be transferred with SFCs 56 and 57 to the module (refer to the *STEP 7* manuals).

Table A-13 Parameters of the SM 331; AI 8 × TC

Parameter	Data Record No.	Parameters can be assigned with ...	
		... SFC 55	... Programming Device
Diagnostics: Group diagnostics	0	No	Yes
Diagnostics: With wire-break check		No	Yes
Diagnostics interrupt enable	1	Yes	Yes
Limit value interrupt enable		Yes	Yes
Cycle end interrupt enable		Yes	Yes
Temperature unit		Yes	Yes
Measuring method	128	Yes	Yes
Measuring range		Yes	Yes
Module filtering mode	128	Yes	Yes
Reaction to open thermocouple		Yes	Yes
Interference suppression		Yes	Yes
Smoothing		Yes	Yes
Upper limit value		Yes	Yes
Lower limit value		Yes	Yes

Note

If you want to enable the diagnostic interrupt in the user program in data record 1, you must enable the diagnosis in data record 0 beforehand using *STEP 7*.

Structure of data record 1

The figure below shows the structure of data record 1 of the SM 331; AI 8 × TC. You activate a parameter by setting the corresponding bit to "1".

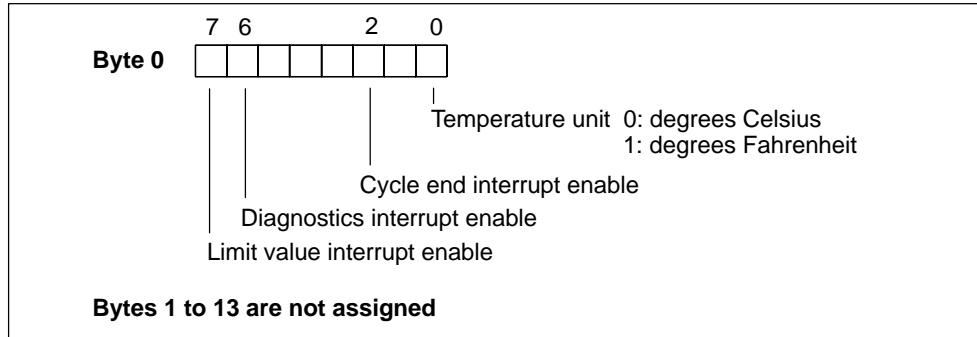

Figure A-8 Data Record 1 of the Parameters for SM 331; AI 8 × TC

Structure of data record 128

The figure below shows the structure of data record 128 for SM 331; AI 8 × TC.

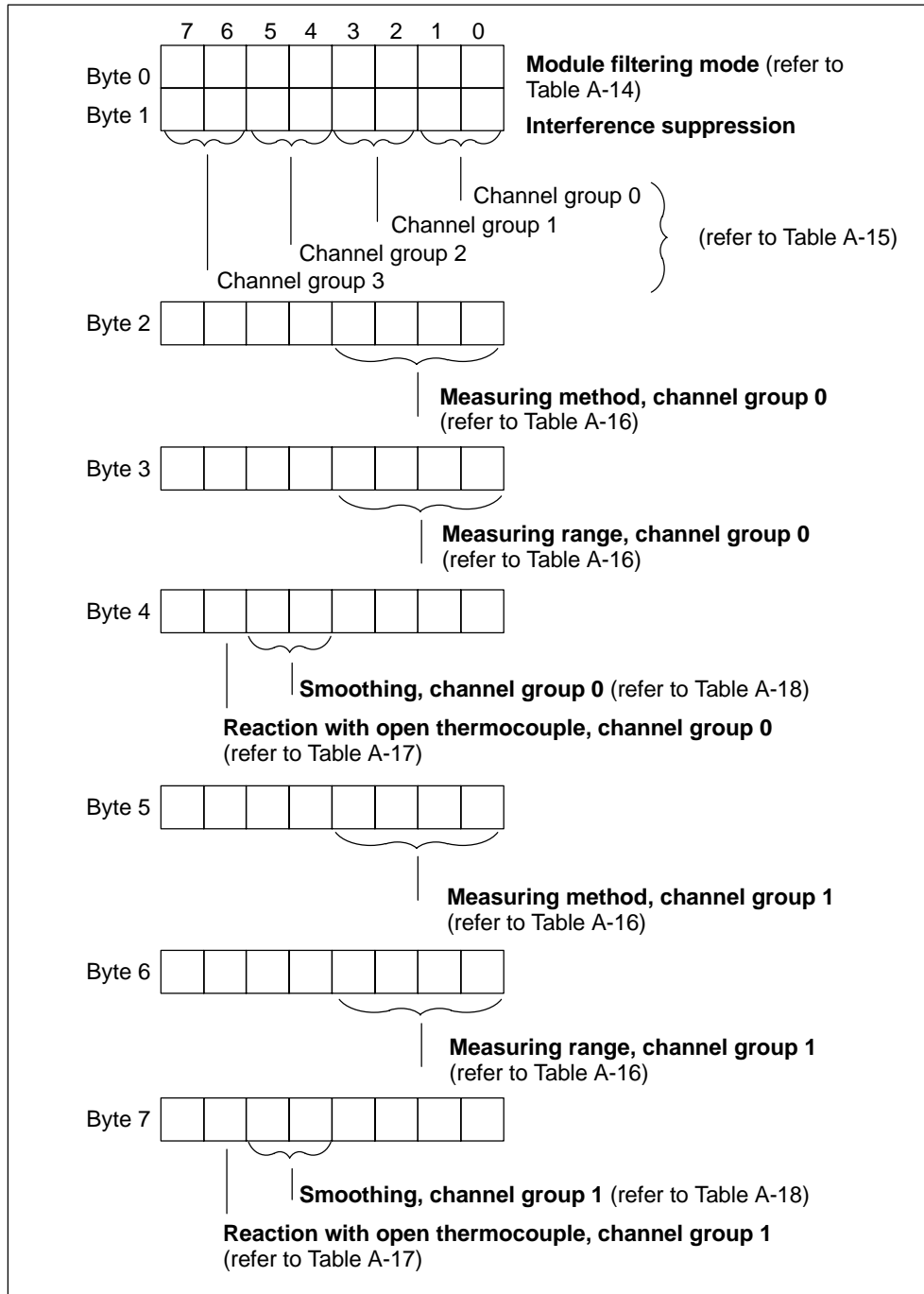

Figure A-9 Data Record 128 of the SM 331; AI 8 × TC

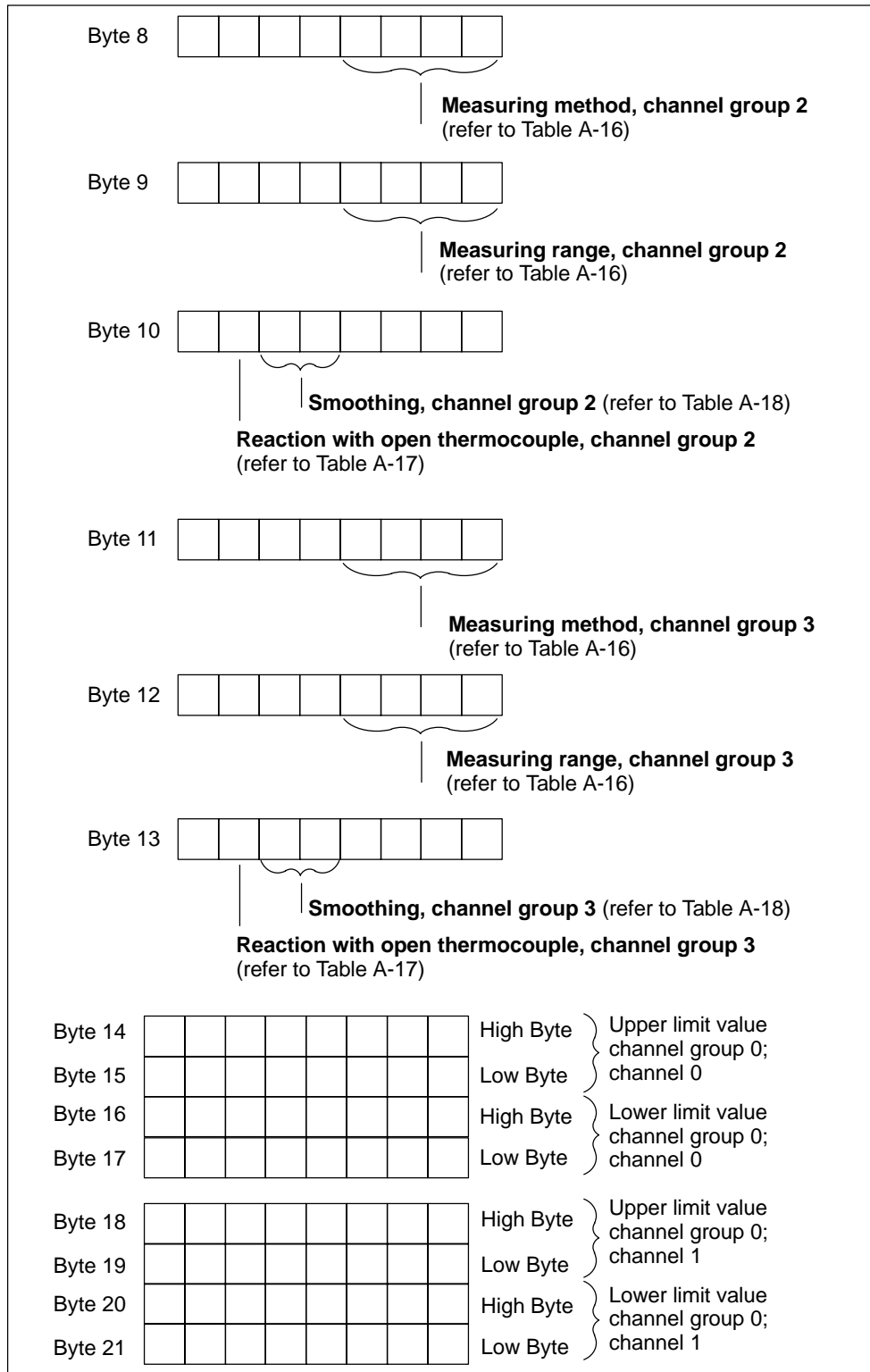

Figure A-10 Data Record 128 of the SM 331; AI 8 x TC (Continued)

Byte 22								High Byte	} Upper limit value channel group 1; channel 2
Byte 23								Low Byte	
Byte 24								High Byte	} Lower limit value channel group 1; channel 2
Byte 25								Low Byte	
Byte 26								High Byte	} Upper limit value channel group 1; channel 3
Byte 27								Low Byte	
Byte 28								High Byte	} Lower limit value channel group 1; channel 3
Byte 29								Low Byte	
Byte 30								High Byte	} Upper limit value channel group 2; channel 4
Byte 31								Low Byte	
Byte 32								High Byte	} Lower limit value channel group 2; channel 4
Byte 33								Low Byte	
Byte 34								High Byte	} Upper limit value channel group 2 channel 5
Byte 35								Low Byte	
Byte 36								High Byte	} Lower limit value channel group 2; channel 5
Byte 37								Low Byte	
Byte 38								High Byte	} Upper limit value channel group 3; channel 6
Byte 39								Low Byte	
Byte 40								High Byte	} Lower limit value channel group 3; channel 6
Byte 41								Low Byte	
Byte 42								High Byte	} Upper limit value channel group 3; channel 7
Byte 43								Low Byte	
Byte 44								High Byte	} Lower limit value channel group 3; channel 7
Byte 45								Low Byte	

Figure A-11 Data Record 128 of the SM 331; AI 8×TC (Continued)

Note

The representation of the limit values matches the analog value representation (see Chapter 4). Please observe the range limits when setting the limit values.

Operating modes of the SM 331; AI 8 × TC

The table below contains the codes for the different operating modes, which you enter in byte 0 of data record 128 (refer to Figure A-5).

Table A-14 Codes of Operating Modes of the SM 331; AI 8 × TC

Module Filtering Mode	Code
8 channels hardware filter	2#00000000
8 channels software filter	2#00000001
4 channels hardware filter	2#00000010

Interference frequency suppression of the SM 331; AI 8 × TC

The table below contains the codes for the different frequencies, which you enter in byte 1 of data record 128 (refer to Figure A-9). Note that the settings 400 Hz, 60 Hz and 50 Hz only apply to 8-channel software filter mode. The setting 50, 60 and 400 Hz only applies to 8-channel and 4-channel hardware filter mode.

Table A-15 Interference Frequency Suppression Codes for SM 331; AI 8 × TC

Interference Suppression	Code
400 Hz	2#00
60 Hz	2#01
50 Hz	2#10
50/60/400 Hz	2#11

Measuring methods and measuring ranges of the SM 331; AI 8 × TC

The table below contains all the measuring methods and measuring ranges of the module and its codes. You must enter these codes in the corresponding bytes of data record 128 (refer to Figure A-3).

Table A-16 Codes for the Measuring Ranges of the SM 331; AI 8 × TC

Measuring Method	Code	Measuring Range	Code
Deactivated	2#0000	Deactivated	2#0000
Thermocouple, linear, reference temperature 0 °C	2#1010	B	2#0000
		N	2#0001
		E	2#0010
		R	2#0011
		S	2#0100
		J	2#0101
		L	2#0110
		T	2#0111
		K	2#1000
U	2#1001		
C	2#1010		
Thermocouple, linear, reference temperature 50 °C	2#1011	B	2#0000
		N	2#0001
		E	2#0010
		R	2#0011
		S	2#0100
		J	2#0101
		L	2#0110
		T	2#0111
		K	2#1000
U	2#1001		
C	2#1010		
Thermocouple, linear, internal comparison	2#1101	B	2#0000
		N	2#0001
		E	2#0010
		R	2#0011
		S	2#0100
		J	2#0101
		L	2#0110
		T	2#0111
		K	2#1000
U	2#1001		
C	2#1010		
Thermocouple, linear, external comparison	2#1110	B	2#0000
		N	2#0001
		E	2#0010
		R	2#0011
		S	2#0100
		J	2#0101
		L	2#0110
		T	2#0111
		K	2#1000
U	2#1001		
C	2#1010		

Reaction to open thermocouple of the SM 331; AI 8 × TC

The table below contains the codes for the reactions to an open thermocouple, which you enter in the corresponding byte of data record 128 (refer to Figure A-9).

Table A-17 Codes of Reaction to Open Thermocouple of the SM 331; AI 8 × TC

Reaction to open thermocouple	Code
Overflow	2#0
Underflow	2#1

Smoothing of the SM 331; AI 8 × TC

The table below contains the codes for all smoothing modes, which you enter in the corresponding byte of data record 128 (refer to Figure A-9).

Table A-18 Codes Smoothing of the SM 331; AI 8 × TC

Smoothing	Code
None	2#00
Low	2#01
Average	2#10
High	2#11

A.7 Parameters of the SM 331; AI 8 × 13 bits

Structure of data record 1

The figure below shows the structure of data record 1 for the parameters of the analog input module.

You activate a parameter by setting the corresponding bit in byte 0 and 1 to "1".

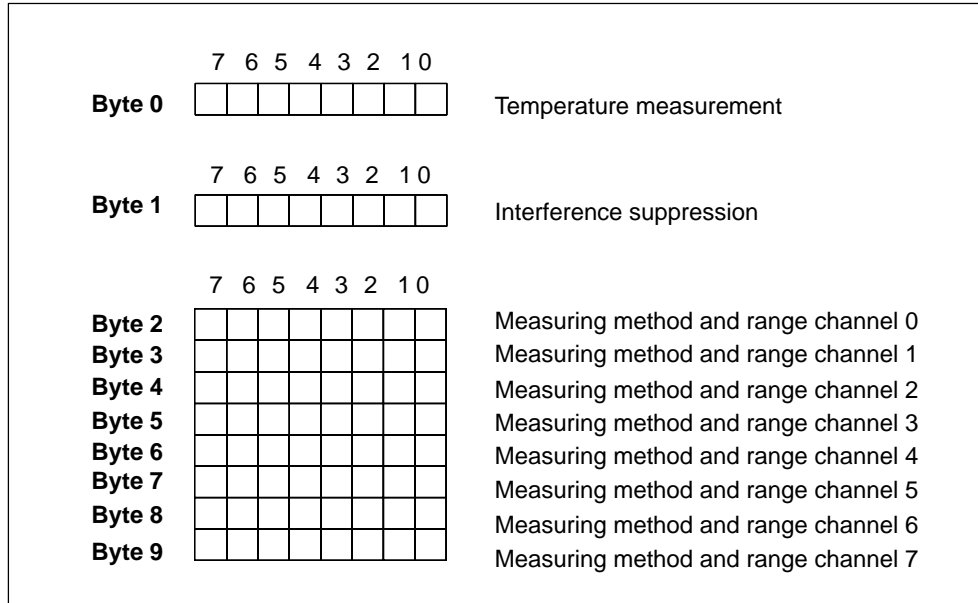

Figure A-12 Data Record 1 for Parameters of the Analog Input Modules

Temperature measurement

The table below contains the codes for the different temperature measurements, which you enter in byte 0 of data record 1 (refer to Figure A-12).

Table A-19 Codes for Temperature Measurement of the Analog Input Module

Temperature unit for linearization	Code
Degrees Celsius	2#0000 0000
Degrees Fahrenheit	2#0000 1000
Kelvin	2#0001 0000

Interference frequency suppression

The table below contains the codes for the different frequencies, which you enter in byte 1 of data record 1 (refer to Figure A-12). You must work out the resulting integration time separately for each module!

Table A-20 Codes for Interference Suppression of the Analog Input Module

Interference Suppression	Integration Time	Code
60 Hz	16.6 ms	2#01
50 Hz	20 ms	2#10

Measuring methods and measuring ranges

The table below contains all the measuring methods and measuring ranges of the analog input module and their codes. You must enter these codes in bytes 2 to 9 of data record 1 (refer to Figure A-12).

Note

Please note that the analog input module must be wired in accordance with the measuring range and at the front connector correspondingly!

Table A-21 Codes for the Measuring Ranges of the Analog Input Module

Measuring Method	Code	Measuring Range	Code
Deactivated	2#0000	Deactivated	2#0000
Voltage	2#0001	± 50 mV ± 500 mV ± 1 V ± 5 V 1 to 5 V 0 to 10 V ± 10 V	2#1011 2#0011 2#0100 2# 0110 2#0111 2#1000 2#1001
Current	2#0010	0 to 20 mA 4 to 20 mA ± 20 mA	2#0010 2#0011 2#0100
Resistors	2#0101	600 Ω 6 kΩ	2#0110 2#1000
Bulb resistor (linear)	2#1001	Pt 100 climate Pt 100 standard range	2#0000 2#0010

A.8 Parameters of the SM 331; AI 8 × 16 bits

Parameters

Table A-22 contains all the parameters which you can set for the isolated analog input module SM 331; AI 8 × 16 bits. This comparison indicates which methods you can use for the configuration of the individual parameters:

- SFC 55 "WR_PARM"
- STEP 7 programming device

The parameters that you have set with STEP 7 can also be transferred to the module by means of SFC 56 or SFC 57.

Table A-22 Parameters for the isolated analog input module SM 331; AI 8 × 16 bits

Parameter	Data Record No.	Configurable with...	
		... SFC 55	...programming device
Diagnostics: Group diagnostics	0	No	Yes
Diagnostics: With wire-break check		No	Yes
Limit value interrupt enable	1	Yes	Yes
Diagnostics interrupt enable		Yes	Yes
Cycle end interrupt enable		Yes	Yes
Module mode	128	Yes	Yes
Interference suppression		Yes	Yes
Measuring method		Yes	Yes
Measuring range		Yes	Yes
Smoothing		Yes	Yes
Upper limit value		Yes	Yes
Lower limit value		Yes	Yes

Note

If you want to enable the diagnostic interrupt in the user program in data record 1, you must enable the diagnosis in data record 0 beforehand using *STEP 7*.

Structure of data record 1

Figure A-13 shows the structure of data record 1 for the parameters of the isolated analog input module SM 331; AI 8×16 bits.

You can activate a parameter by setting the corresponding bit in byte 0 to "1".

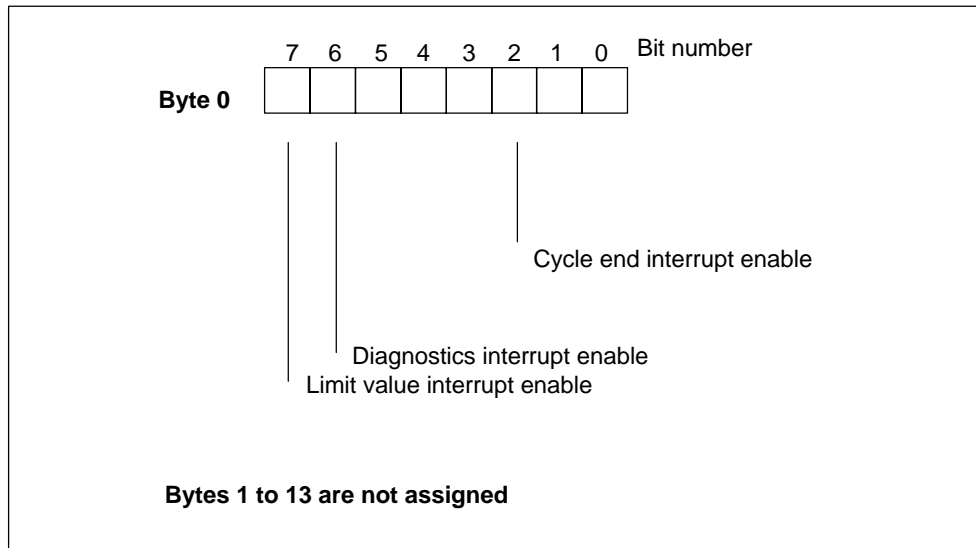

Figure A-13 Data Record 1 of the Parameters for SM 331; AI 8×16 bits

Structure of data record 128

Figure A-14, A-15, A-16 shows the structure of data record 128 for the parameters of the isolated analog input module SM 331; AI 8×16 bits.

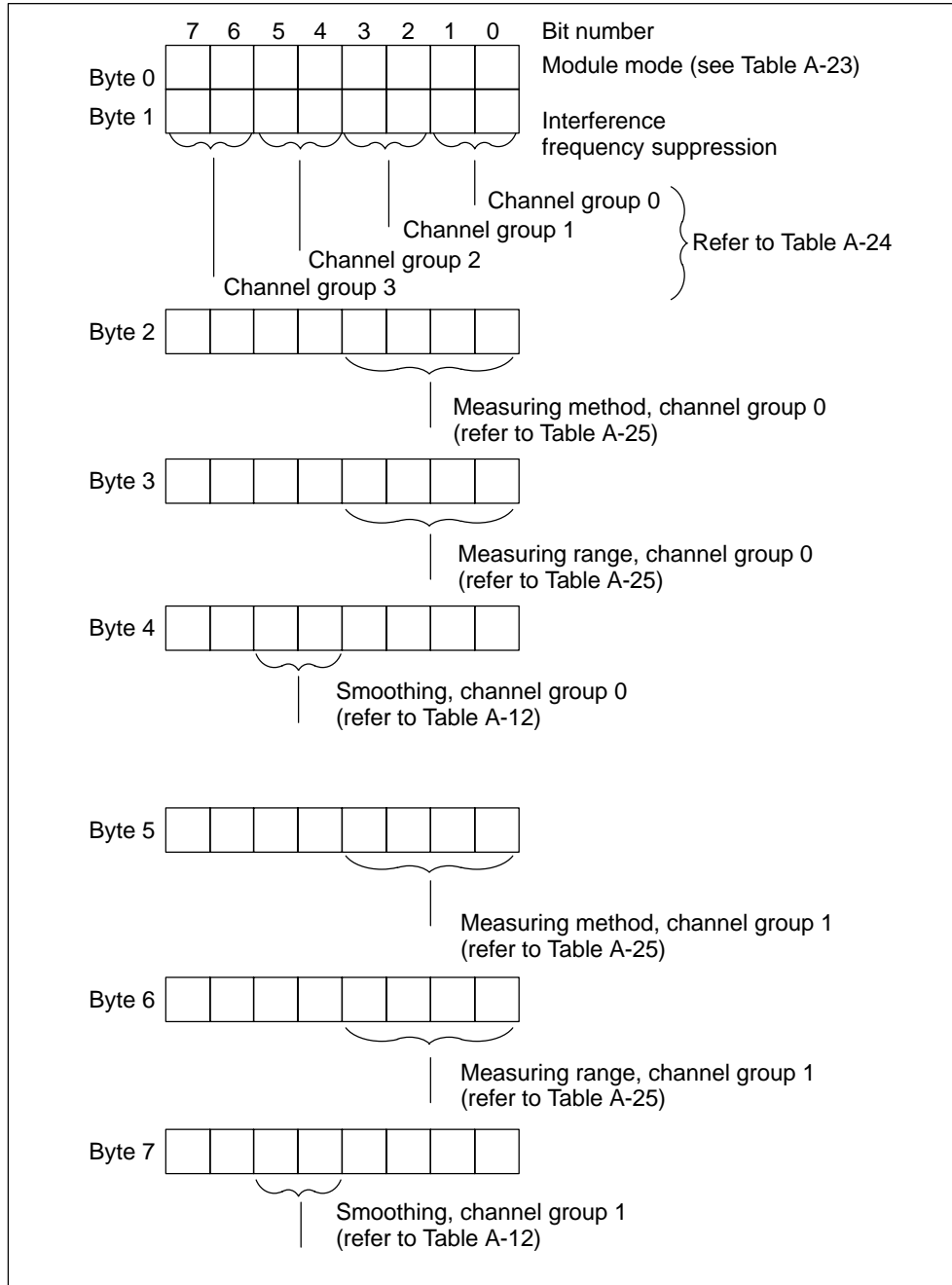

Figure A-14 Data record 128 for parameters of the SM 331; AI 8×16 bits

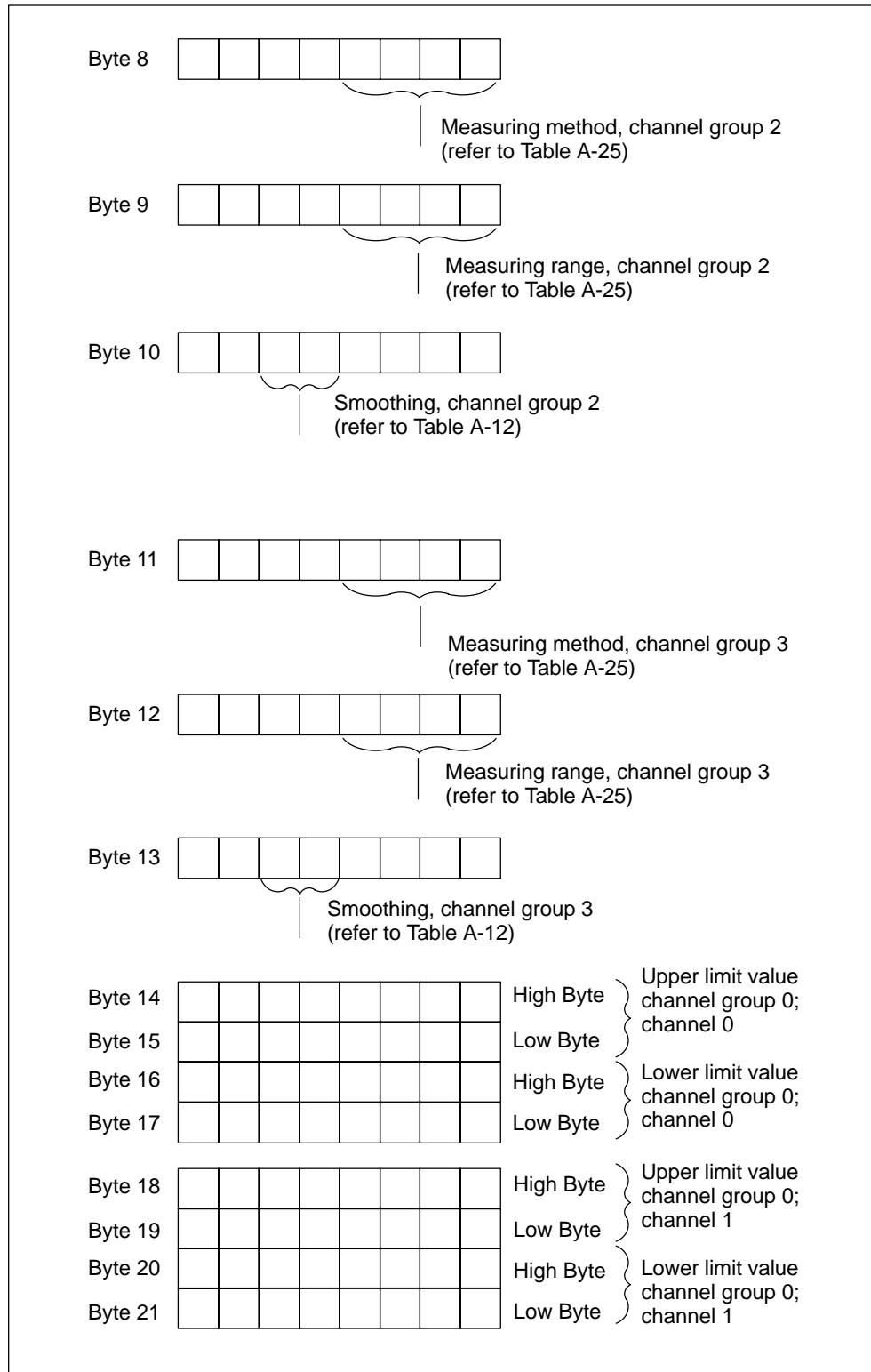

Figure A-15 Data record 128 for SM 331; AI 8 × 16 bits (continued)

Byte 22								High Byte	} Upper limit value channel group 1; channel 2
Byte 23								Low Byte	
Byte 24								High Byte	} Lower limit value channel group 1; channel 2
Byte 25								Low Byte	
Byte 26								High Byte	} Upper limit value channel group 1; channel 3
Byte 27								Low Byte	
Byte 28								High Byte	} Lower limit value channel group 1; channel 3
Byte 29								Low Byte	
Byte 30								High Byte	} Upper limit value channel group 2; channel 4
Byte 31								Low Byte	
Byte 32								High Byte	} Lower limit value channel group 2; channel 4
Byte 33								Low Byte	
Byte 34								High Byte	} Upper limit value channel group 2 channel 5
Byte 35								Low Byte	
Byte 36								High Byte	} Lower limit value channel group 2; channel 5
Byte 37								Low Byte	
Byte 38								High Byte	} Upper limit value channel group 3; channel 6
Byte 39								Low Byte	
Byte 40								High Byte	} Lower limit value channel group 3; channel 6
Byte 41								Low Byte	
Byte 42								High Byte	} Upper limit value channel group 3; channel 7
Byte 43								Low Byte	
Byte 44								High Byte	} Lower limit value channel group 3; channel 7
Byte 45								Low Byte	

Figure A-16 Data record 128 for parameters of the SM 331; AI 8 × 16 bits (continued)

Note

The representation of the limit values matches the analog value representation (see Chapter 4). Please observe the range limits when setting the limit values.

Module modes

Table A-23 contains the codes for the module modes, which you enter in byte 0 of data record 128 (see Figure A-14).

Table A-23 Codes for the Modes of SM 331; AI 8 × 16 bits

Module Mode	Code
8 channels	2#00000000
4 channels	2#00000001

Interference suppression

Table A-24 contains the codes for the different frequencies, which you enter in byte 1 of data record 128 (see Figure A-5). Note that 4-channel mode only functions if interference frequency suppression of 50, 60 and 400 Hz is set.

Table A-24 Codes for Interference Frequency Suppression of the SM 331; AI 8 × 16 bits

Interference Suppression	Code
400 Hz	2#00
60 Hz	2#01
50 Hz	2#10
50, 60 und 400 Hz	2#11

Measuring methods and measuring ranges

Table A-25 contains all the measuring ranges for the isolated analog input module SM 331; AI 8 × 16 bits. Table A-25 also shows the codes for measuring methods and measuring ranges. You must enter these codes in accordance with the required measuring range in the relevant byte of data record 128 (see Figure A-14).

Table A-25 Codes for the Measuring Ranges of the SM 331; AI 8 × 16 bits

Measuring Method	Code	Measuring Range	Code
Deactivated	2#0000	Deactivated	2#0000
Voltage	2#0001	± 5 V	2#0110
		1 to 5 V	2#0111
		± 10 V	2#1001
Current (4-wire transmitter)	2#0002	0 to 20 mA	2#0010
		4 to 20 mA	2#0011
		± 20 mA	2#0100

Settings for input smoothing

Table A-26 contains all the smoothing settings for the isolated analog input module SM 331; AI 8 × 16 bits. You must enter these codes in accordance with the required smoothing mode in the relevant byte of data record 128 (see Figure A-14).

Table A-26 Codes for the Smoothing Mode Settings of the SM 331; AI 8 × 16 bits

Smoothing mode setting	Code
None	2#00
Low	2#01
Average	2#10
High	2#11

A.9 Parameters of the Analog Output Modules

Parameters

Table A-27 contains all the parameters you can set for analog output modules.. The comparison shows:

- Which parameters you can change with *STEP 7* and
- Which parameters you can change with SFC 55 "WR_PARM".

The parameters which you set with *STEP 7* can also be transferred to the module with SFCs 56 and 57.

Table A-27 Parameters of the Analog Output Modules

Parameter	Data Record No.	Parameters can be assigned with ...	
		... SFC 55	... Programming Device
Diagnostics: Group diagnostics	0	No	Yes
Diagnostics interrupt enable	1	Yes	Yes
Behavior on CPU STOP		Yes	Yes
Output type		Yes	Yes
Output range		Yes	Yes
Substitute value		Yes	Yes

Note

If you want to enable the diagnostic interrupt in the user program in data record 1, you must enable the diagnosis in data record 0 beforehand using *STEP 7*.

Data record 1 structure

The figure below shows the structure of data record 1 for the parameters of the analog output modules.

You activate the diagnostics interrupt enable by setting the corresponding bit in byte 0 to "1".

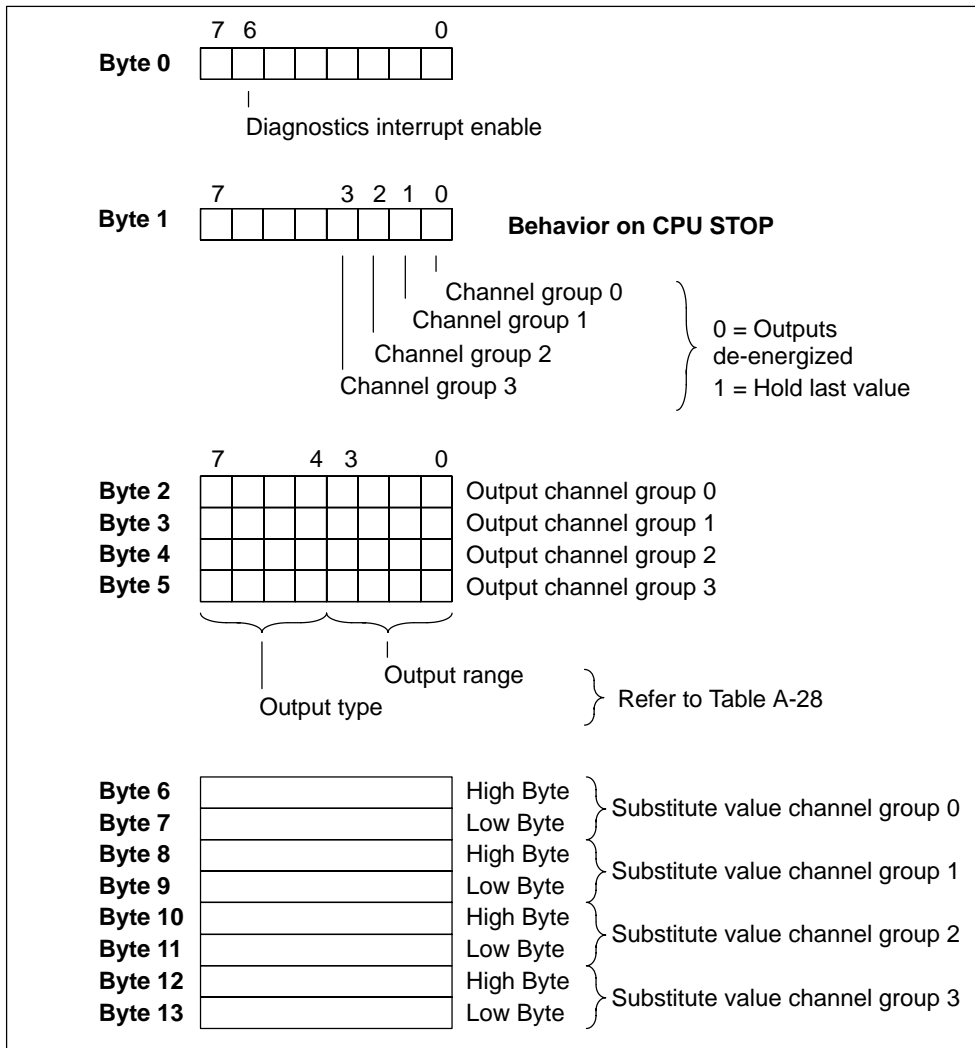

Figure A-17 Data Record 1 for Parameters of the Analog Output Modules

Setting substitute values

Note

For output ranges 4 to 20 mA and 1 to 5 V you must set the substitute value E500_H so that the output remains de-energized (refer to Tables 4-35 and 4-37 on pages 4-29 and 4-30).

The representation of the substitute values corresponds to the analog value representation. You should observe the relevant range limits when setting the substitute values.

Output methods and output ranges

The table below contains all the output methods and output ranges of the analog output modules and their codes. You must enter these codes in bytes 2 to 5 of data record 1 (refer to Figure A-17).

Table A-28 Codes for the Output Ranges of the Analog Output Modules

Output type	Code	Output Range	Code
Deactivated	2#0000	Deactivated	2#0000
Voltage	2#0001	1 to 5 V 0 to 10 V ± 10 V	2#0111 2#1000 2#1001
Current	2#0010	0 to 20 mA 4 to 20 mA ± 20 mA	2#0010 2#0011 2#0100

A.10 Parameters of the SM 332; AO 8 × 12 bits

Parameters

Table A-27 contains all the parameters that you can set for the analog output module SM 332; AO 8 × 12 bits. The comparison shows:

- Which parameters you can change with *STEP 7* and
- Which parameters you can change with SFC 55 "WR_PARM".

The parameters which you set with *STEP 7* can also be transferred to the module with SFCs 56 and 57.

Table A-29 Parameters of the SM 332; AO 8 × 12 bits.

Parameter	Data Record No.	Parameters can be assigned with ...	
		... SFC 55	... Programming Device
Diagnostics: Group diagnostics	0	No	Yes
Diagnostics interrupt enable	1	Yes	Yes
Behavior on CPU STOP		Yes	Yes
Output type		Yes	Yes
Output range		Yes	Yes

Note

If you want to enable the diagnostic interrupt in the user program in data record 1, you must enable the diagnosis in data record 0 beforehand using *STEP 7*.

Structure of data record 1

The diagram below shows the structure of data record 1 of the parameters of the SM 332; AO 8 × 12 bits.

You activate the diagnostics interrupt enable by setting the corresponding bit in byte 0 to "1".

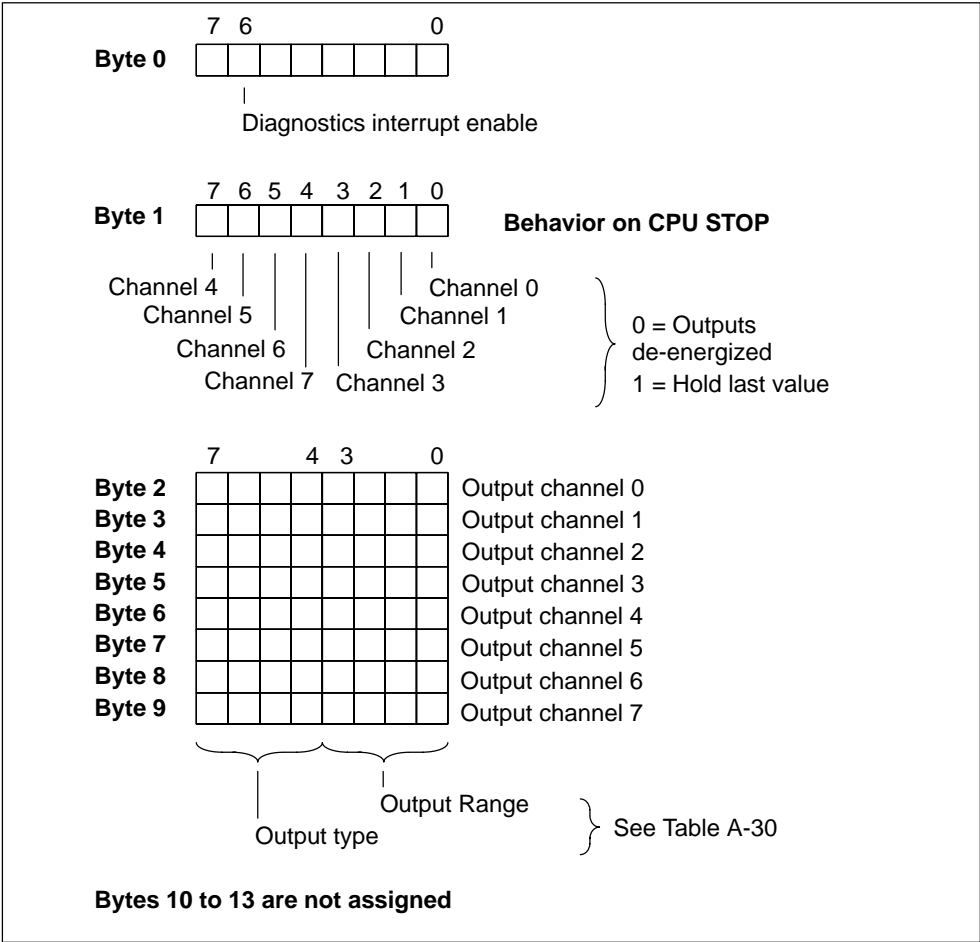

Figure A-18 Data Record 1 for Parameters of the Analog Output Modules

Output method and output range

The following table contains all the output methods and output ranges of the SM 332; AO 8 × 12 bits, with their coding. You must enter these codes in bytes 2 to 9 of data record 1 (refer to Figure A-18).

Table A-30 Codes for the Output Ranges of the Analog Output Module SM332; AO 8 × 12 bits

Output Type	Code	Output Range	Code
Deactivated	2#0000	Deactivated	2#0000
Voltage	2#0001	1 to 5 V	2#0111
		0 to 10 V	2#1000
		± 10 V	2#1001
Current	2#0010	0 to 20 mA	2#0010
		4 to 20 mA	2#0011
		± 20 mA	2#0100

A.11 Parameters of the Analog Input/Output Modules

Parameters

The table below contains all the parameters you can set for analog input/output modules.

You will see which parameters you can modify from the list:

- In *STEP 7*
- With SFC 55 "WR_PARM"

The parameters set with *STEP 7* can also be transferred with SFCs 56 and 57 to the module (refer to the *STEP 7* manuals).

Table A-31 Parameters of the Analog Input/Output Modules

Parameter	Data Record No.	Parameters can be assigned with ...	
		... SFC 55	... Programming Device
Measuring method	1	Yes	Yes
Measuring range		Yes	Yes
Integration time		Yes	Yes
Output type		Yes	Yes
Output range		Yes	Yes

Structure of data record 1

The figure below shows the structure of data record 1 for the parameters of the analog input/output modules.

You activate a parameter by setting the corresponding bit in byte 0 and 1 to "1".

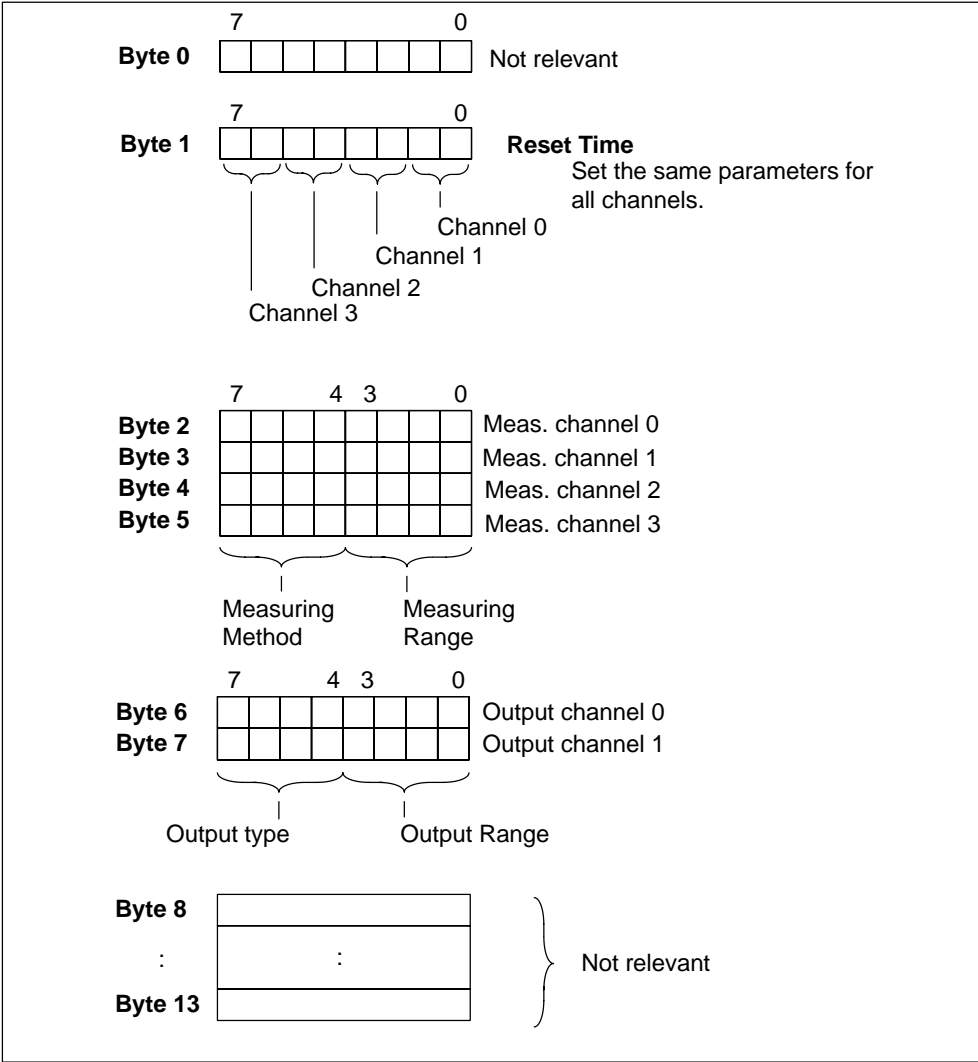

Figure A-19 Data Record 1 for Parameters of the Analog Input/Output Modules

Measuring methods and measuring ranges

The table below contains all the measuring methods and measuring ranges of the analog input/output modules and their codes. You must enter these codes in bytes 2 to 5 of data record 1 (refer to Figure A-19).

Table A-32 Codes for the Measuring Ranges of the Analog Input/Output Modules

Measuring Method	Code	Measuring Range	Code
Deactivated	2#0000	Deactivated	2#0000
Voltage	2#0001	0 to 10 V	2#1000
Resistance, four-conductor connection	2#0100	10 k Ω	2#1001
Thermal resistance + linearization four-conductor connection	2#1000	Pt 100 climate	2#0000

Output methods and output ranges

The table below contains all the output methods and output ranges of the analog input/output modules and their codes. You must enter these codes in bytes 6 and 7 of data record 1 (refer to Figure A-19).

Table A-33 Codes for the Output Ranges of the Analog Input/Output Modules

Output type	Code	Output Range	Code
Deactivated	2#0000	Deactivated	2#0000
Voltage	2#0001	0 to 10 V	2#1000

Diagnostics Data of Signal Modules

B

In this Appendix

Section	Contents	Page
B.1	Evaluating Diagnostic Data of the Signal Modules in the User Program	B-1
B.2	Structure and Content of Diagnostic Data Bytes 0 to 7	B-2
B.3	Channel-Specific Diagnostic Data from Byte 7	B-5
B.4	Diagnostic Data of the SM 338; POS-INPUT	B-7

B.1 Evaluating Diagnostic Data of the Signal Modules in the User Program

In this Appendix

This Appendix describes the structure of the diagnostic data in the system data. You must be familiar with this configuration if you want to evaluate the diagnostics data of the signal module in the *STEP 7* user program.

Diagnostic data are contained in data records

The diagnostic data of a module can be up to 16 bytes long and are contained in data records 0 and 1:

- Data record 0 contains 4 bytes of diagnostic data that describe the current status of a programmable logic controller.
- Data record 1 contains the four bytes of diagnostic data that are also contained in data record 0 **and** as many as 12 bytes of module specific diagnostic data.

Further references

An in-depth description of the principle of evaluating the diagnostic data of signal modules in the user program and a description of the SFCs that can be used for that purpose will be found in the *STEP 7* manuals.

B.2 Structure and Content of Diagnostic Data Bytes 0 to 7

The structure and contents of the different bytes of the diagnostic data are described below. The following general rule applies: When an error occurs, the bit concerned is set to "1".

Bytes 0 and 1

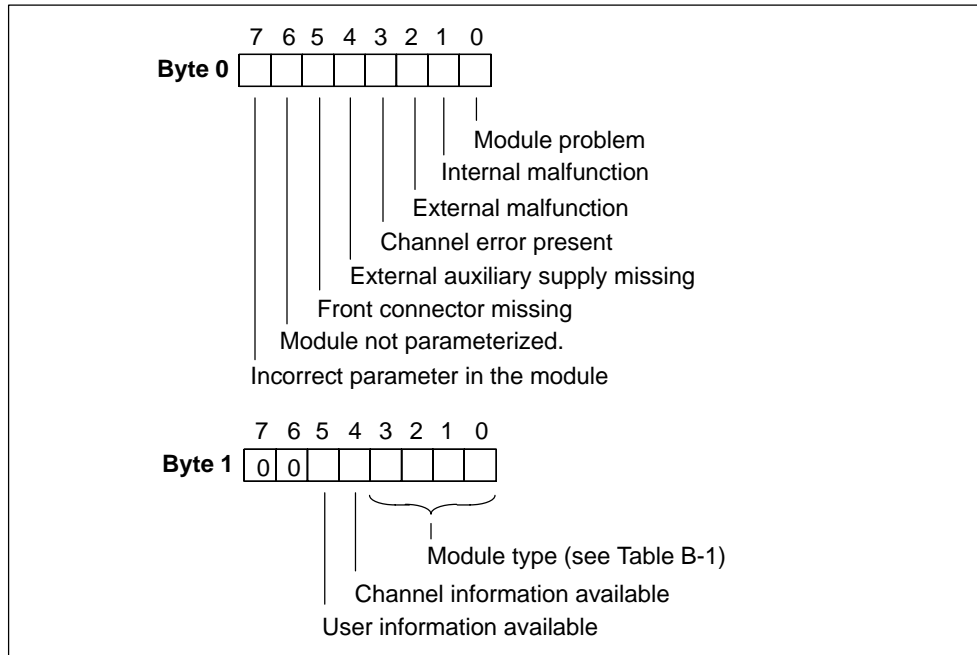

Figure B-1 Bytes 0 and 1 of the Diagnostic Data

Module types

The following table contains the IDs of the module classes (bits 0 to 3 in byte 1).

Table B-1 Codes of the Module Types

Code	Module Type
0101	Analog module
0110	CPU
1000	Function module
1100	CP
1111	Digital module

Bytes 2 and 3

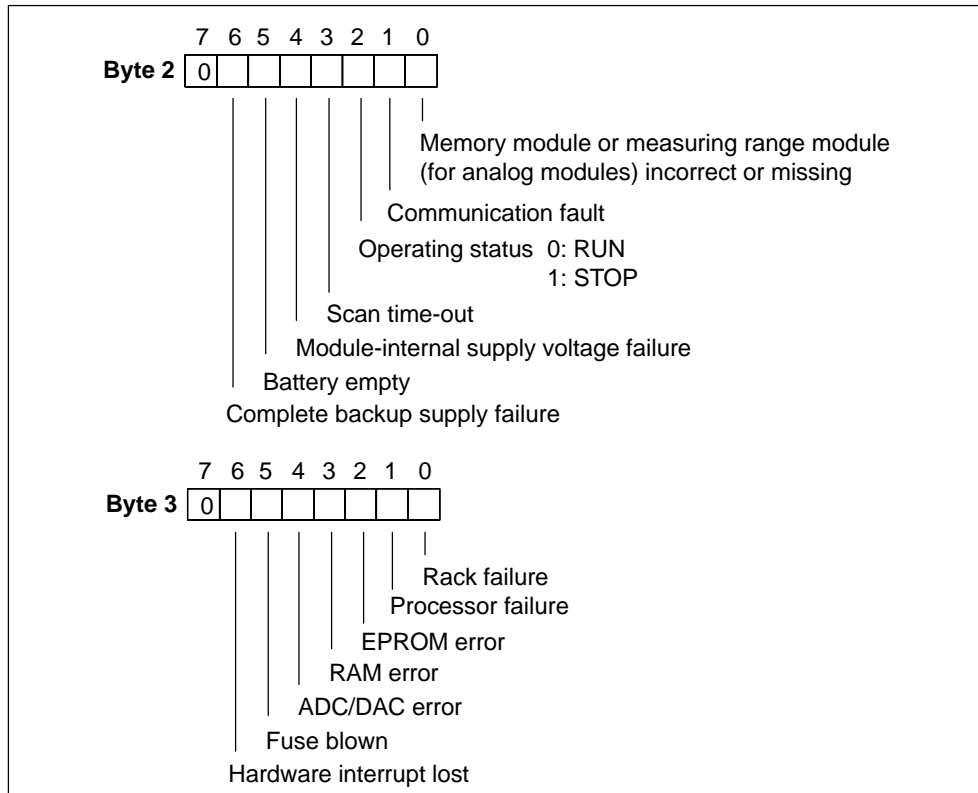

Figure B-2 Bytes 2 and 3 of the Diagnostics Data

Bytes 4 to 7

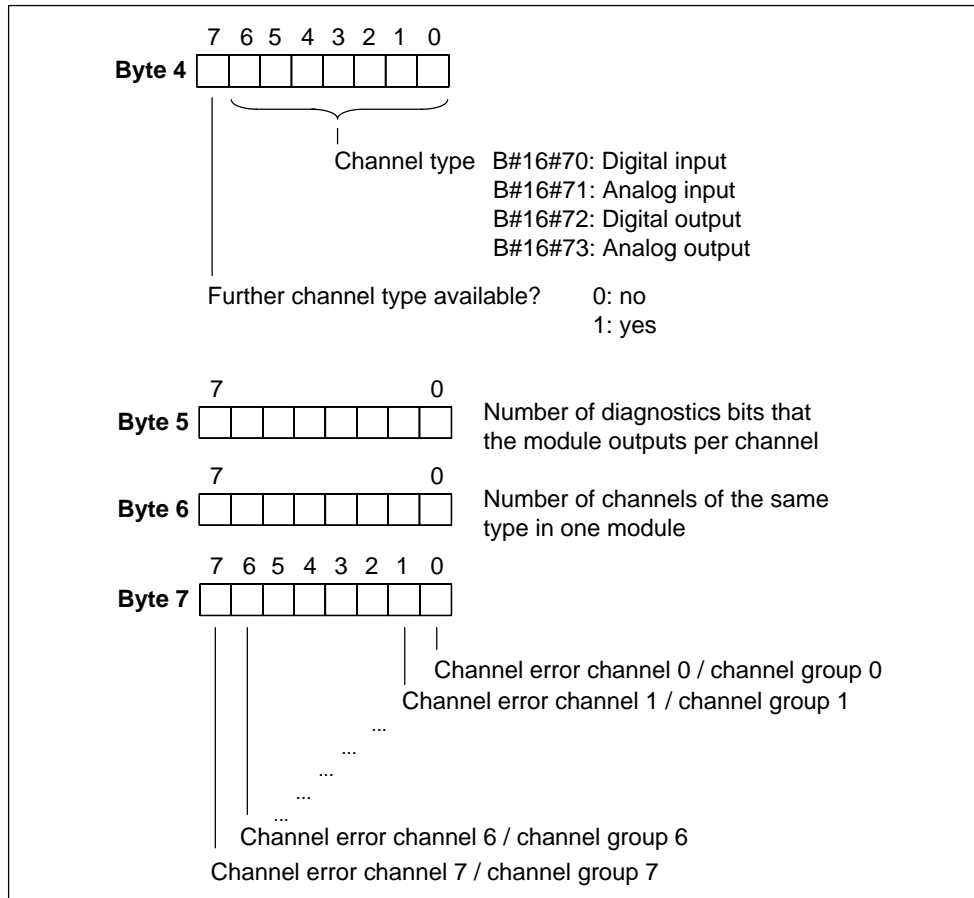

Figure B-3 Bytes 4 to 7 of the Diagnostics Data

B.3 Channel-Specific Diagnostic Data from Byte 8

From byte 8 up to byte 15, data record 1 contains the channel-specific diagnostic data. The figures below show the assignment of the diagnostic byte for a channel or a channel group of the specific module. The following general rule applies: When an error occurs, the bit concerned is set to "1".

You will find a description of possible error causes and appropriate remedies in the section called "Diagnostics of the Modules".

Digital input channel of the SM 321; DI 16 × 24 VDC; with hardware and diagnostic interrupts

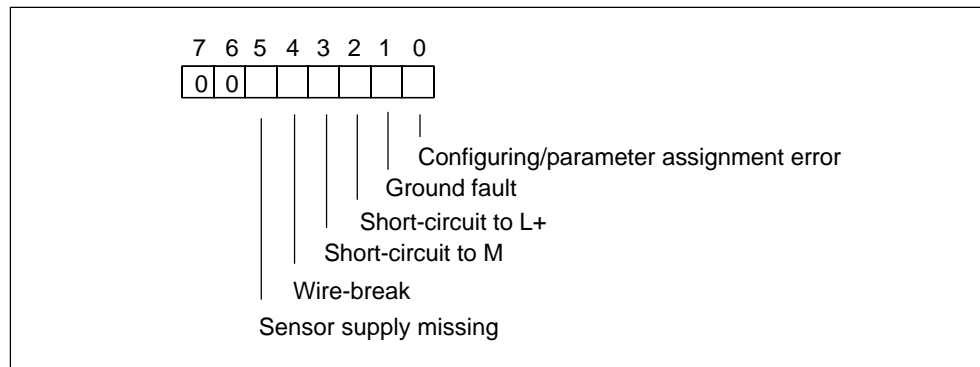

Figure B-4 Diagnostic Byte for a Digital Input Channel of the SM 321; DI 16 x 24 VDC

Digital output channel of the SM 322; DO 8 × 24 VDC/0.5 A; with diagnostic interrupt

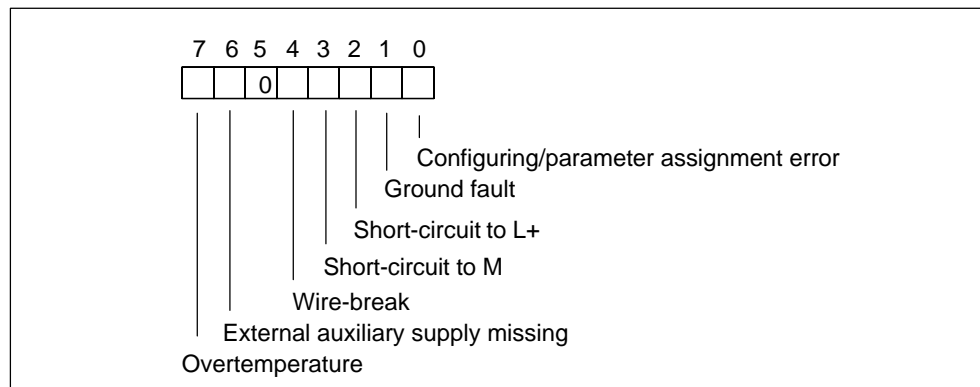

Figure B-5 Diagnostic Byte for a Digital Output Channel of the SM 322; DO 8 x 24 VDC/0.5 A

Analog input channel of the SM 331 modules with diagnostics capability

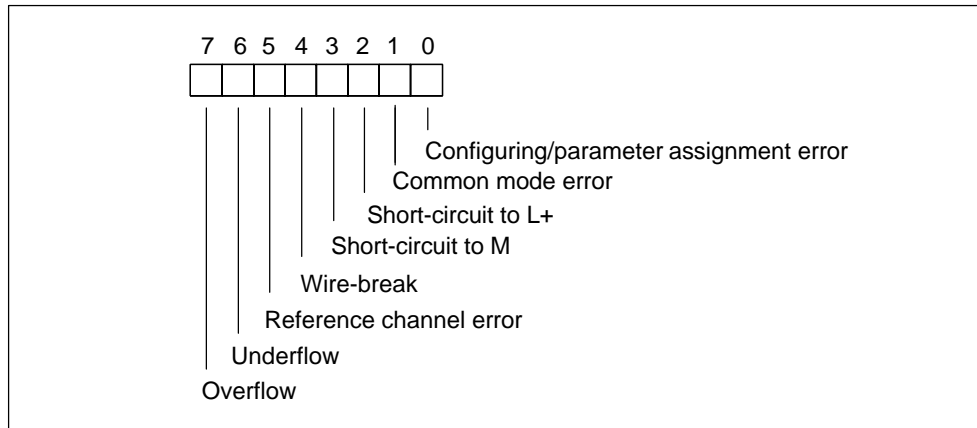

Figure B-6 Diagnostic Byte for an Analog Input Channel of a SM 331 with Diagnostics Capability

Analog output channel of the SM 332 modules with diagnostics capability

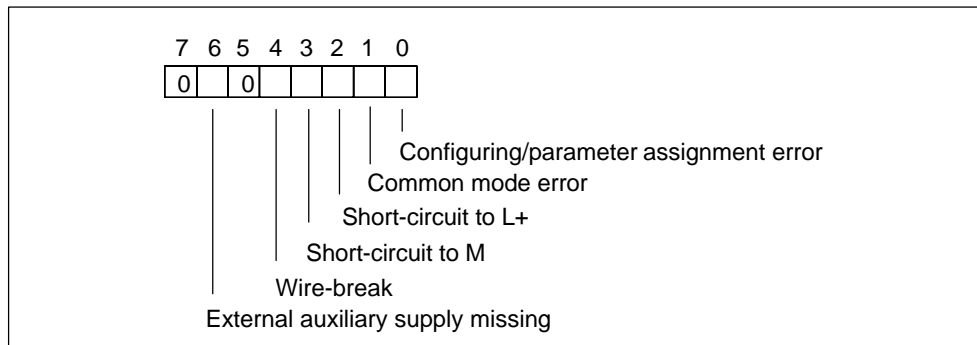

Figure B-7 Diagnostic Byte for an Analog Output Channel of a SM 332 with Diagnostics Capability

B.4 Diagnostic Data of the SM 338; POS-INPUT

The structure and contents of the different bytes of the diagnostic data for position detection module SM 338; POS-INPUT are described below. The following general rule applies: When an error occurs, the bit concerned is set to "1".

Section 5.4 includes a description of possible error causes and appropriate remedies.

Bytes 0 and 1

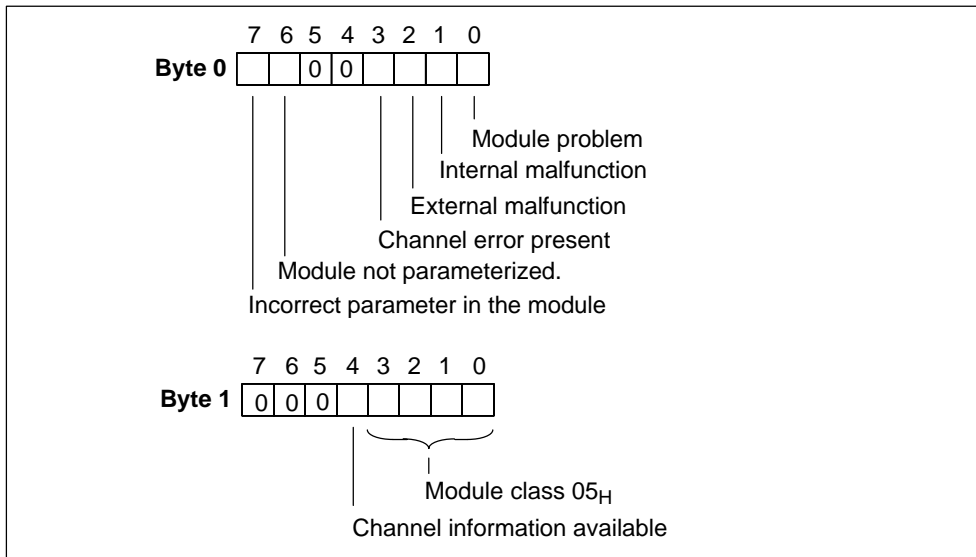

Figure B-8 Bytes 0 and 1 of the Diagnostic Data for the SM 338; POS-INPUT

Bytes 2 to 7

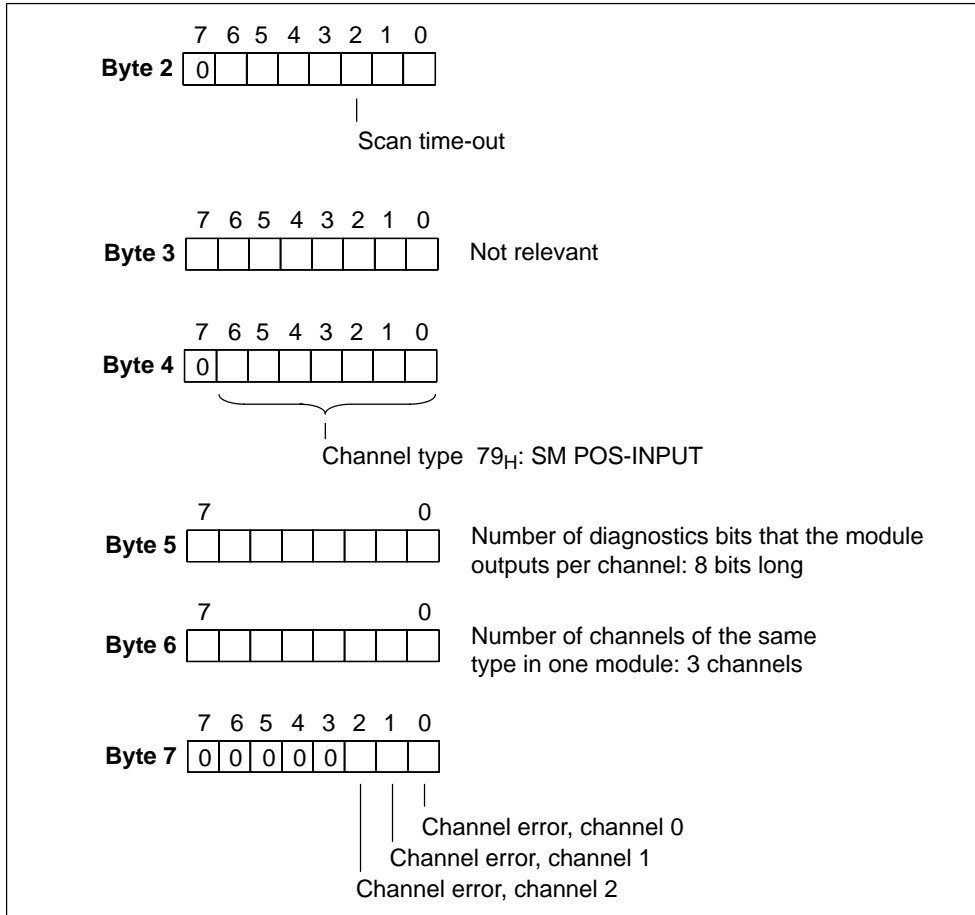

Figure B-9 Bytes 2 and 7 of the Diagnostic Data for the SM 338; POS-INPUT

Bytes 8 to 10

From byte 8 up to byte 10, data record 1 contains the channel-specific diagnostic data. The figure below shows the assignment of the diagnostic byte for a channel of the SM 338; POS-INPUT.

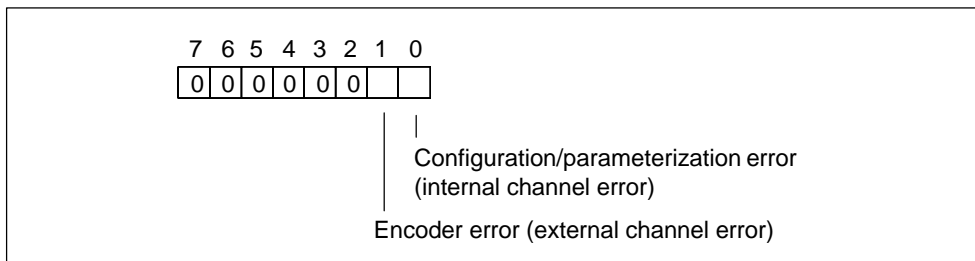

Figure B-10 Diagnostic Byte for a Channel of the SM 338; POS-INPUT

C

Dimension Drawings

Introduction

In this appendix, you will find the dimension drawings for the most important components of an S7-300. The specifications in these dimension drawings are required for dimensioning the S7-300 configuration. The dimensions of an S7-300 configuration must be taken into account when installing an S7-300 in cabinets, switchgear rooms, etc. This appendix does not contain any dimension drawings of the CPUs of the S7-300 or M7-300 or of the IM 153-1. These dimension drawings are contained in the relevant manuals.

Contents

In this appendix, you will find the dimension drawings of the following S7-300 components.

Section	Contents	Page
C.1	Dimension Drawings of the Rails	C-2
C.2	Dimension Drawings of the Power Supply Modules	C-9
C.3	Dimension Drawings of the Interface Modules	C-14
C.4	Dimension Drawings of the Signal Modules	C-14
C.5	Dimension Drawings for Accessories	C-17

C.1 Dimension Drawings of the Rails

483 mm standard rail

Figure C-1 shows the dimension drawing of the 483 mm standard rail.

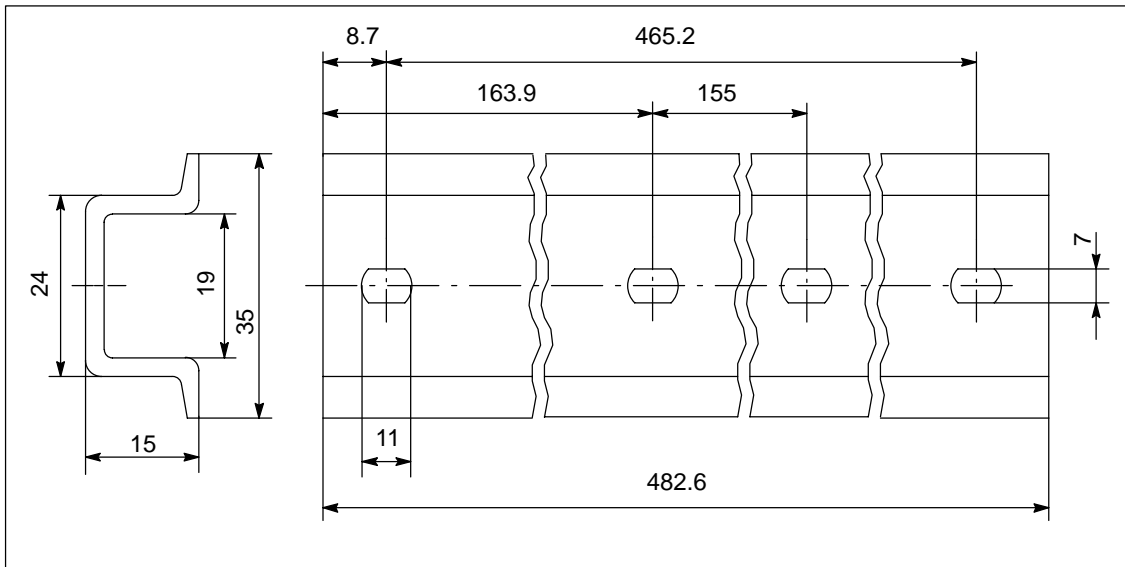

Figure C-1 Dimension Drawing of the 483 mm Standard Rail

530 mm standard rail

Figure C-2 shows the dimension drawing of the 530 mm standard rail.

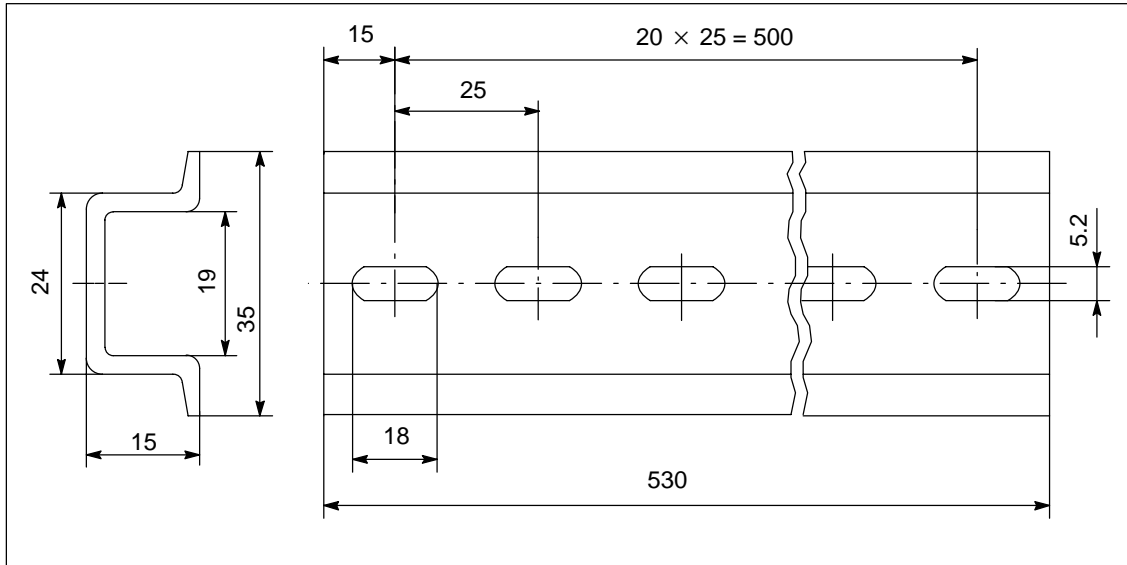

Figure C-2 Dimension Drawing of the 530 mm Standard Rail

830 mm standard rail

Figure C-3 shows the dimension drawing of the 830 mm standard rail.

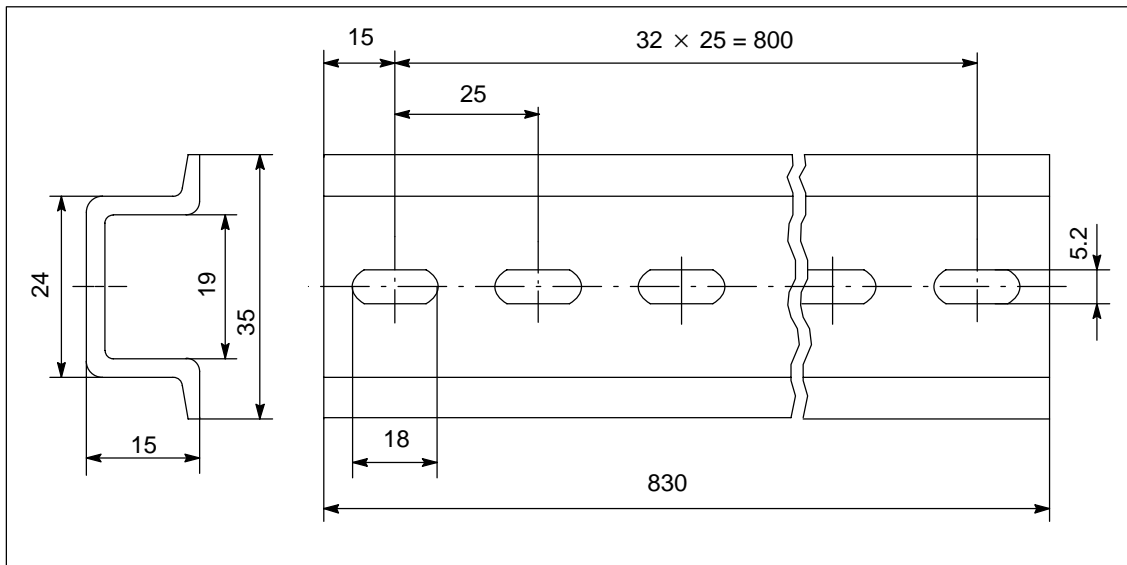

Figure C-3 Dimension Drawing of the 830 mm Standard Rail

2000 mm standard rail

Figure C-4 shows the dimension drawing of the 2000 mm standard rail.

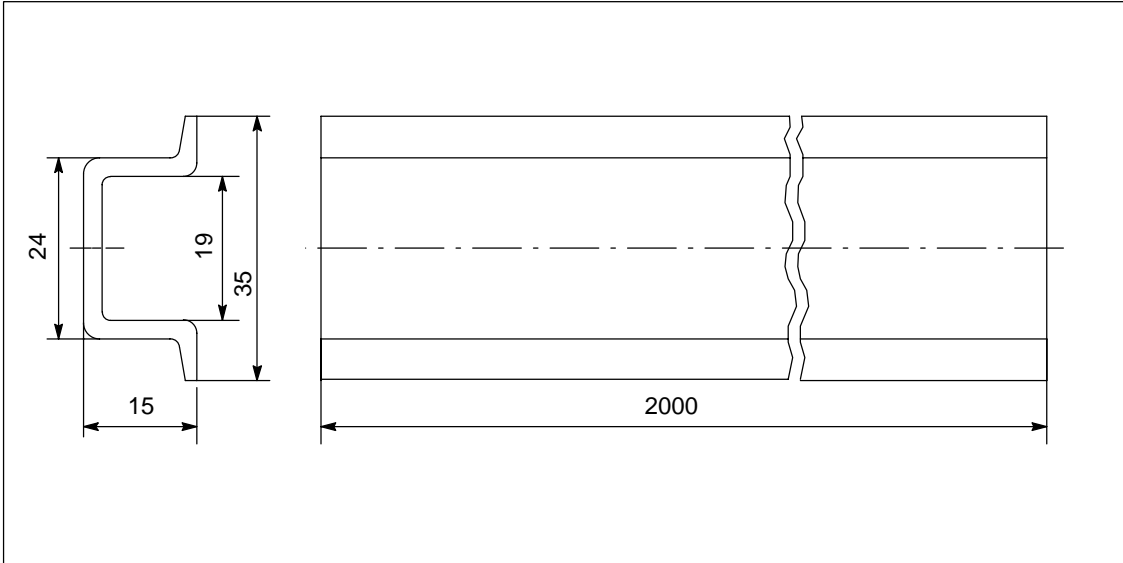

Figure C-4 Dimension Drawing of the 2000 mm Standard Rail

160 mm rail

Figure C-5 shows the dimension drawing of the 160 mm rail.

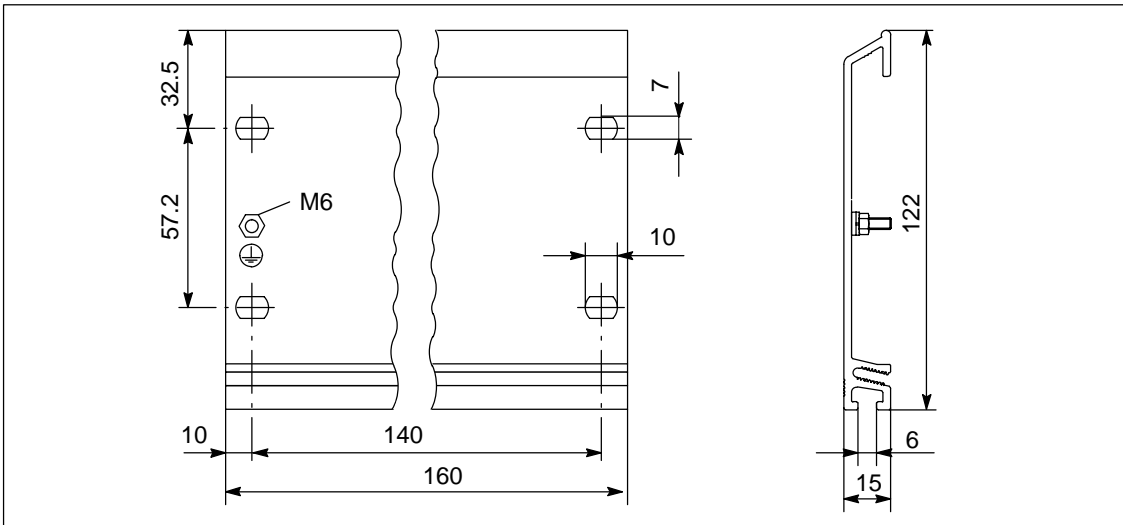

Figure C-5 Dimension Drawing of the Rail with 160 mm Standard Width

482.6 mm rail

Figure C-6 shows the dimension drawing of the 482.6 mm rail.

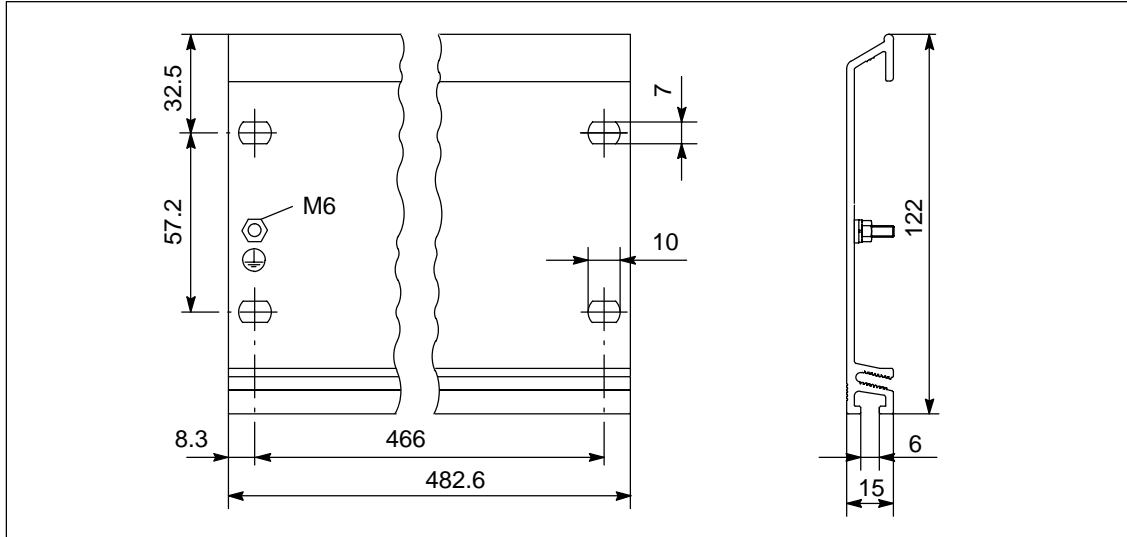

Figure C-6 Dimension Drawing of the Rail with 482.6 mm Standard Width

530 mm rail

Figure C-7 shows the dimension drawing of the 530 mm rail.

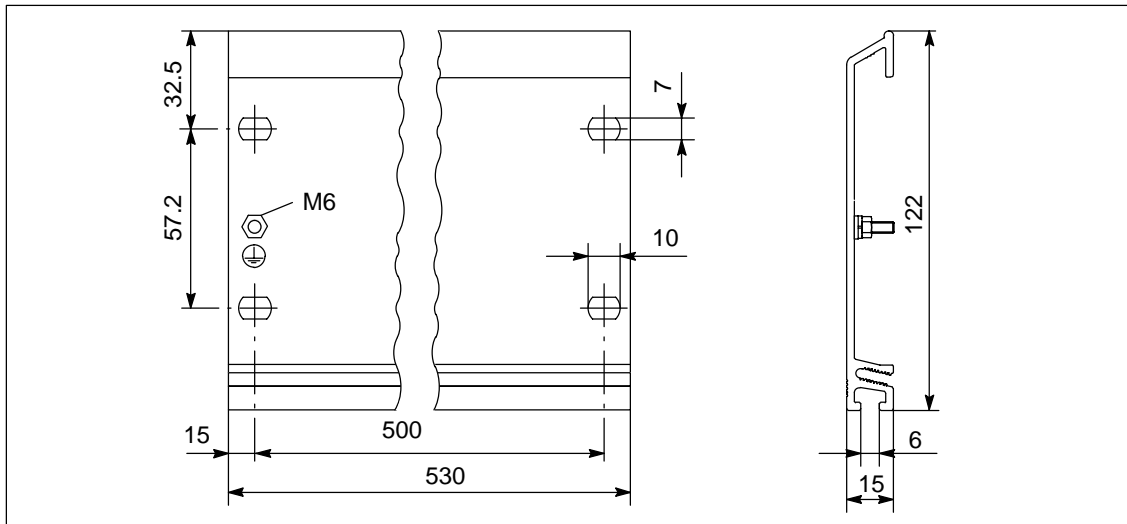

Figure C-7 Dimension Drawing of the Rail with 530 mm Standard Width

830 mm rail

Figure C-8 shows the dimension drawing of the 830 mm rail.

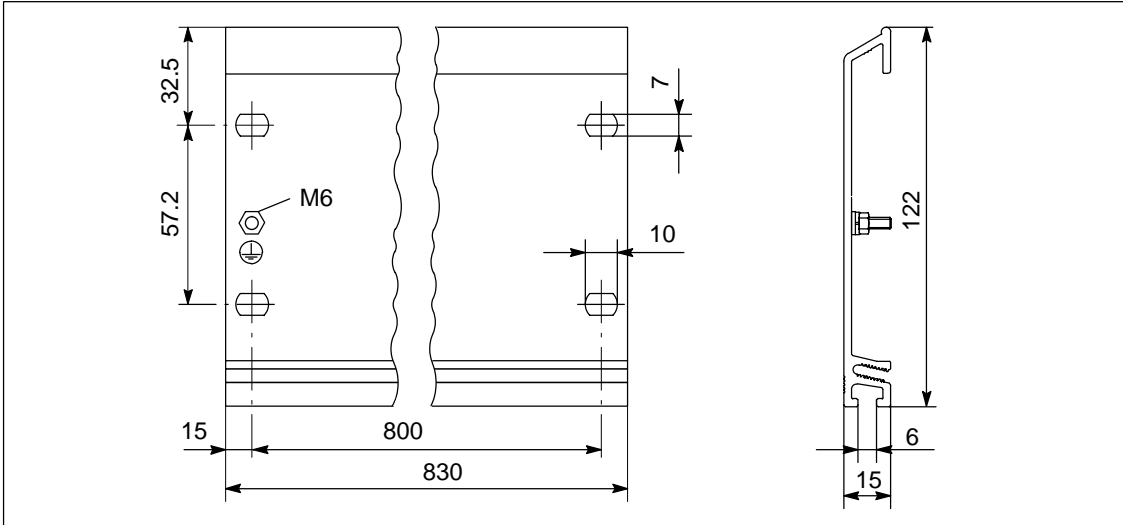

Figure C-8 Dimension Drawing of the Rail with 830 mm Standard Width

2000 mm rail

Figure C-9 shows the dimension drawing of the 2000 mm rail.

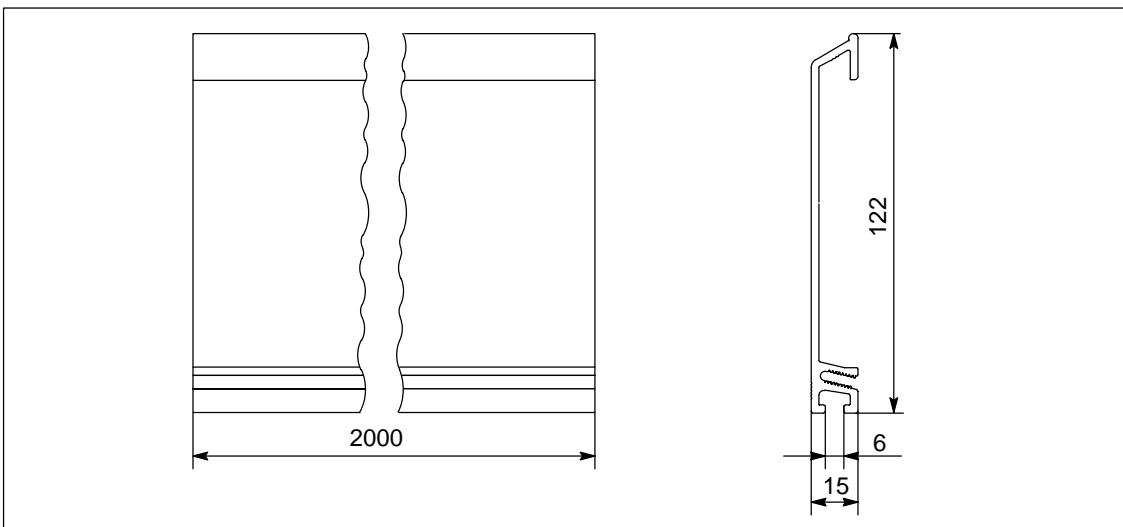

Figure C-9 Dimension Drawing of the 2000 mm Rail

Rail for "Insert and Remove" function

Figure C-10 shows the dimension drawing of the rail for the "Insert and Remove" function with active bus module, S7-300 module and explosion-proof partition. The rail is 482.6 mm or 530 mm long.

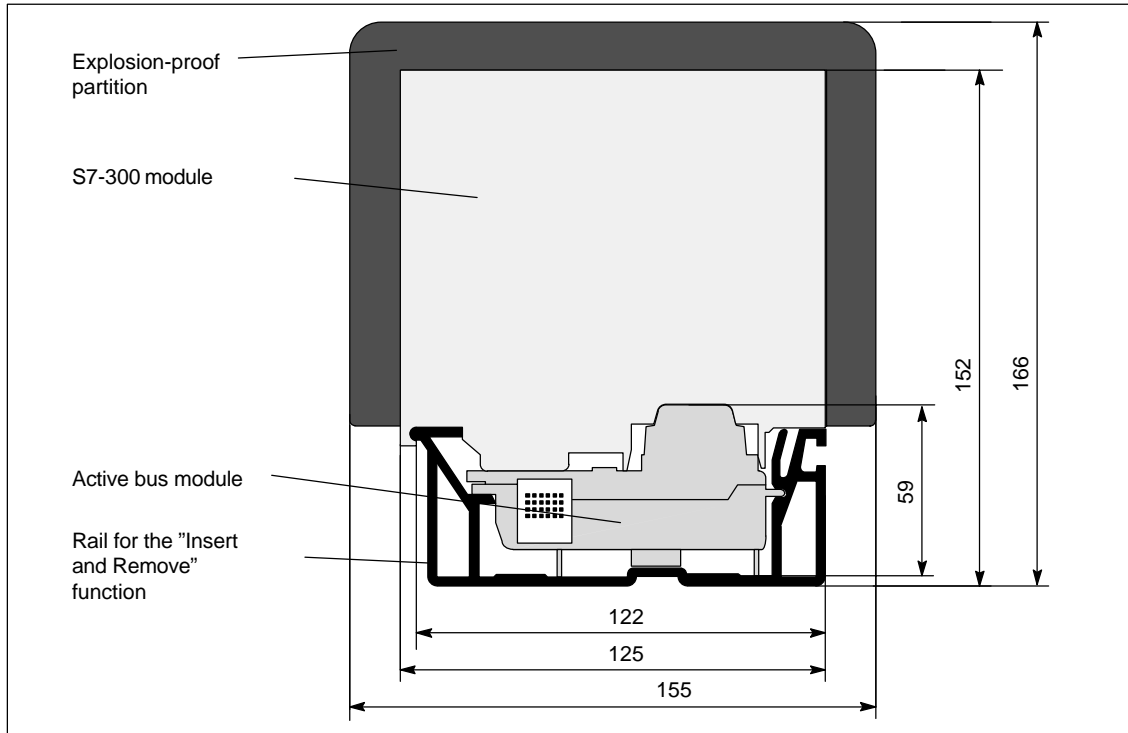

Figure C-10 Complete Dimension Drawing of a Rail for "Insert and Remove" Function with Active Bus Module, S7-300 Module and Explosion-proof Partition

Bus modules (Expansion buses)

Figure C-11 shows the dimension drawing of the active bus module for the "Insert and Remove" function.

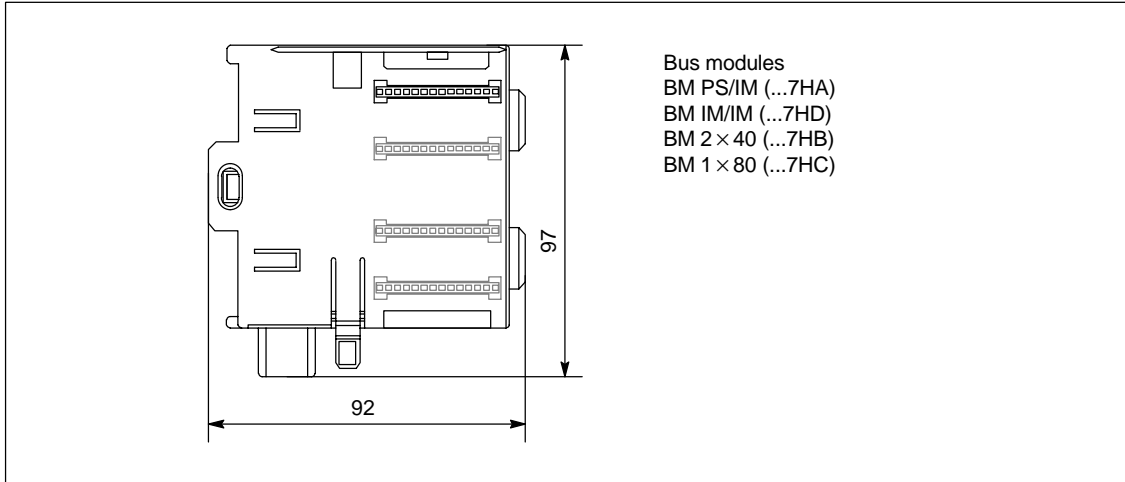

Figure C-11 Dimension Drawing of the Active Bus Modules

C.2 Dimension Drawings of the Power Supply Modules

PS 307; 2 A

Figure C-12 shows the dimension drawing of the PS 307; 2 A power supply module.

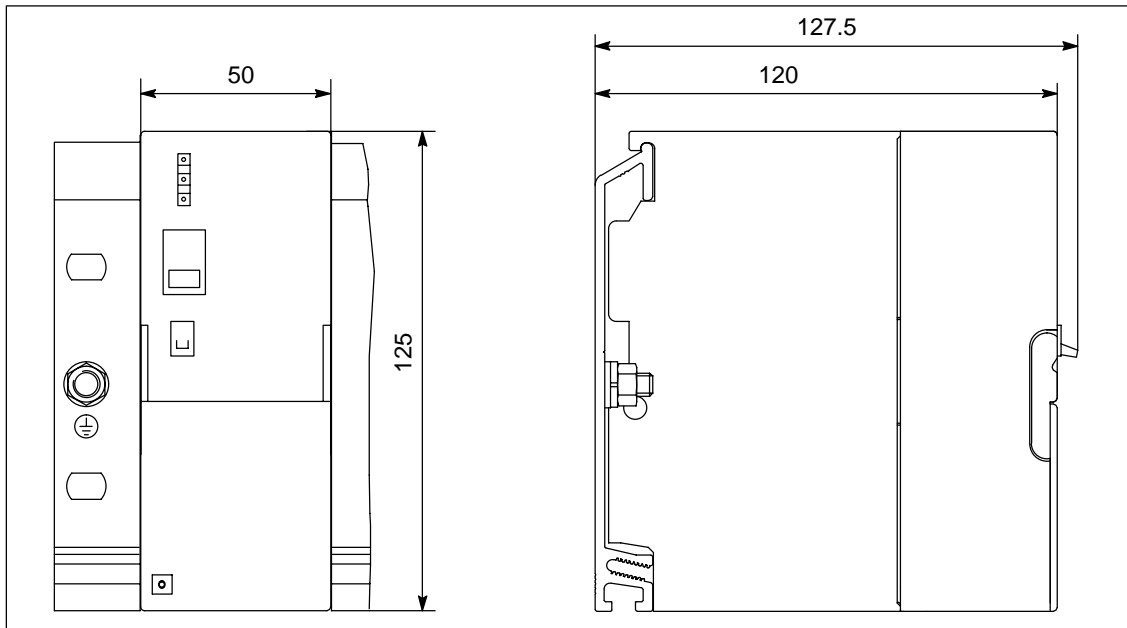

Figure C-12 Power Supply Module PS 307; 2 A

PS 307; 5A

Figure C-13 shows the dimension drawing of the PS 307; 5 A power supply module.

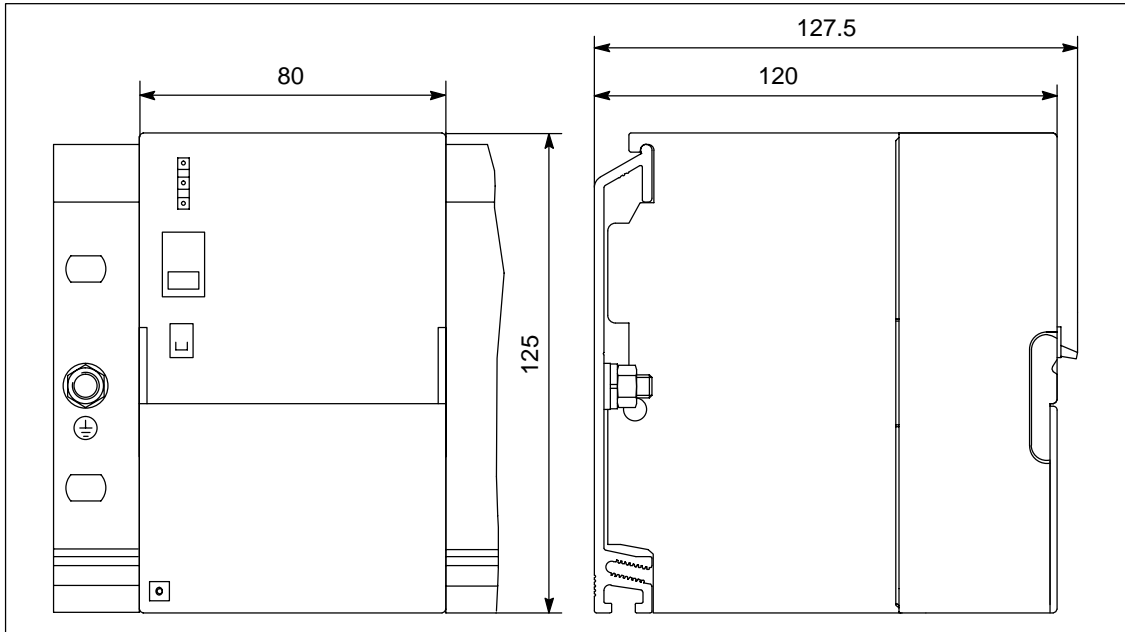

Figure C-13 Power Supply Module PS 307; 5 A

PS 307; 10 A

Figure C-14 shows the dimension drawing of the PS 307; 10 A power supply module.

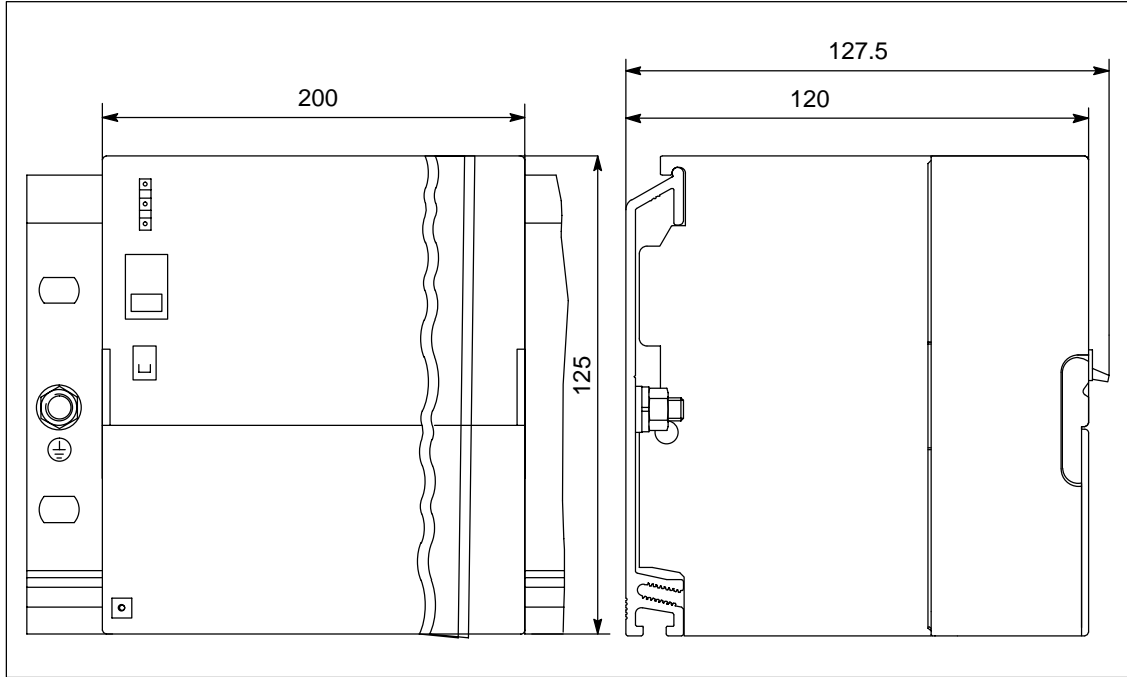

Figure C-14 Power Supply Module PS 307; 10 A

PS 307; 5 A with CPUs 313/314/315/315-2 DP

Figures C-15 and C-16 show the dimension drawings of the configuration of a power supply module PS 307; 5 A with the CPUs 313/314/315/315-2 DP. Observe the dimensions that result from the use of the power connector for wiring the PS 307; 5 A with the CPU.

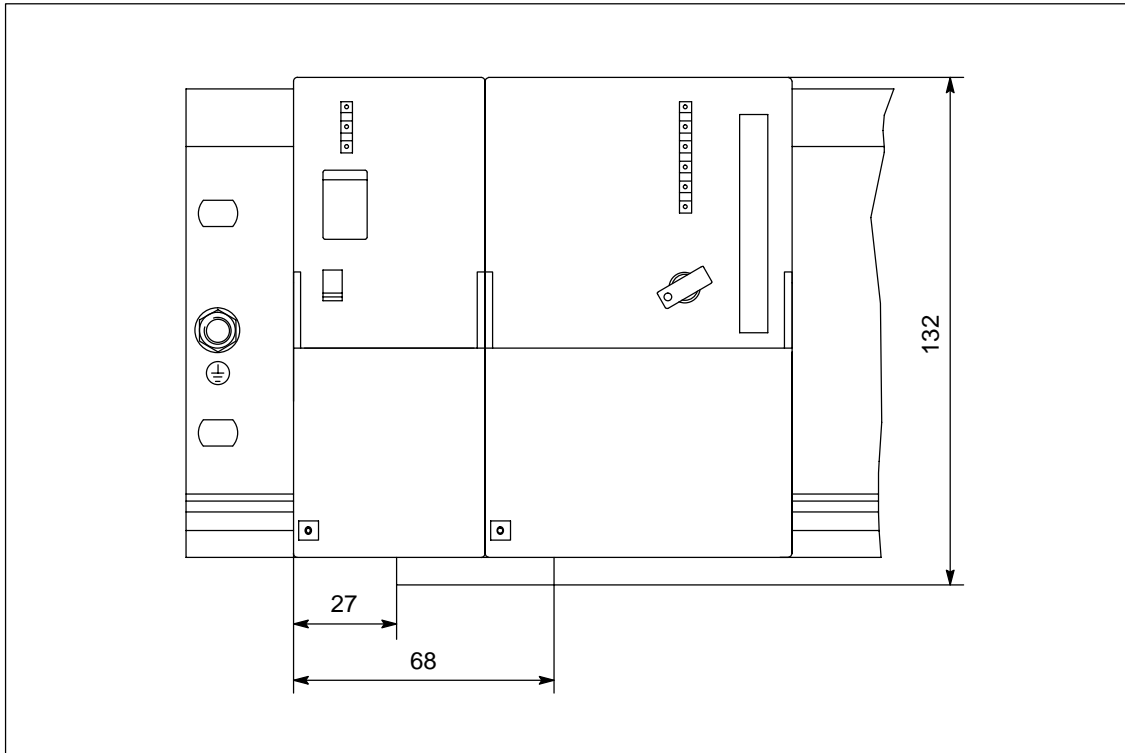

Figure C-15 Dimension Drawing of the Power Supply Module PS 307; 5 A with CPUs 313/314/315/315-2 DP. Front View

PS 307; 5 A with CPUs 313/314/315/315-2 DP

Figure C-16 shows the dimension drawing of the power supply module PS 307; 5 A with the CPUs 313/314/315/315-2 DP in the side view.

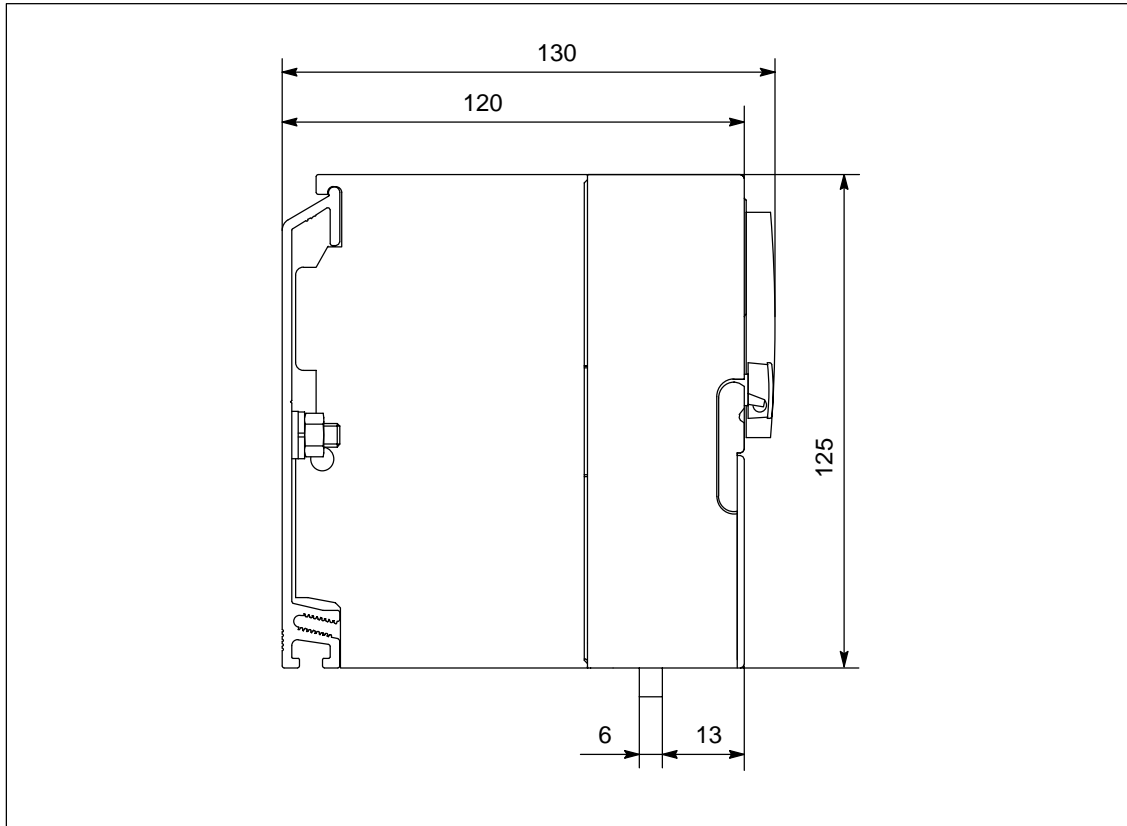

Figure C-16 Dimension Drawing of the Power Supply Module PS 307; 5 A with CPUs 313/314/315/315-2 DP. Side View

C.3 Dimension Drawings of the Interface Modules

IM 360

Figure C-17 shows the dimension drawing of the interface module IM 360.

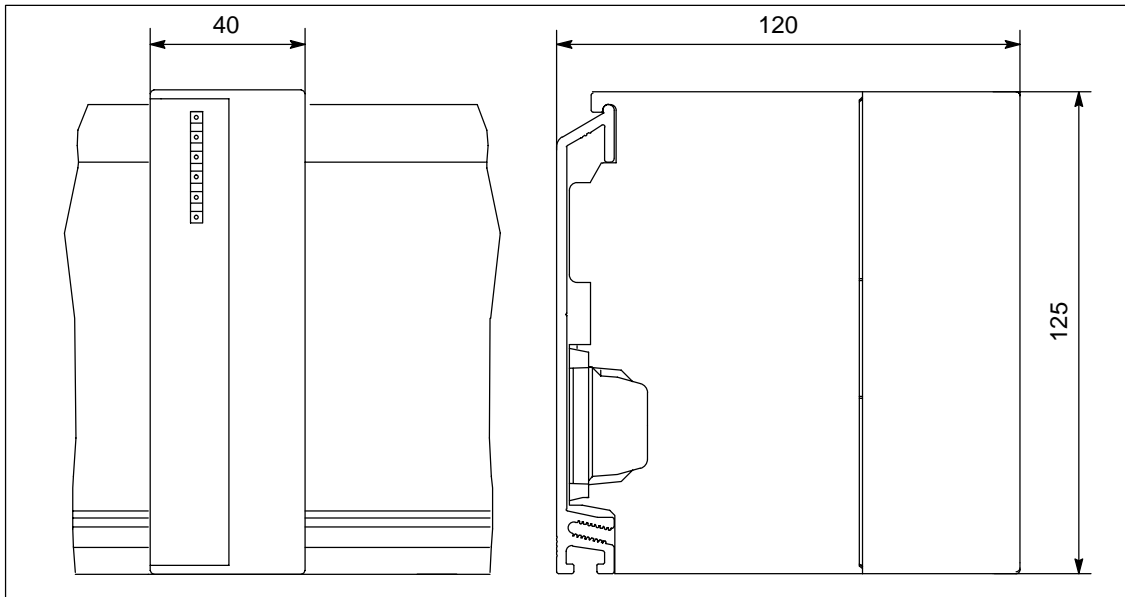

Figure C-17 Interface Module IM 360

IM 361

Figure C-18 shows the dimension drawing of the interface module IM 361.

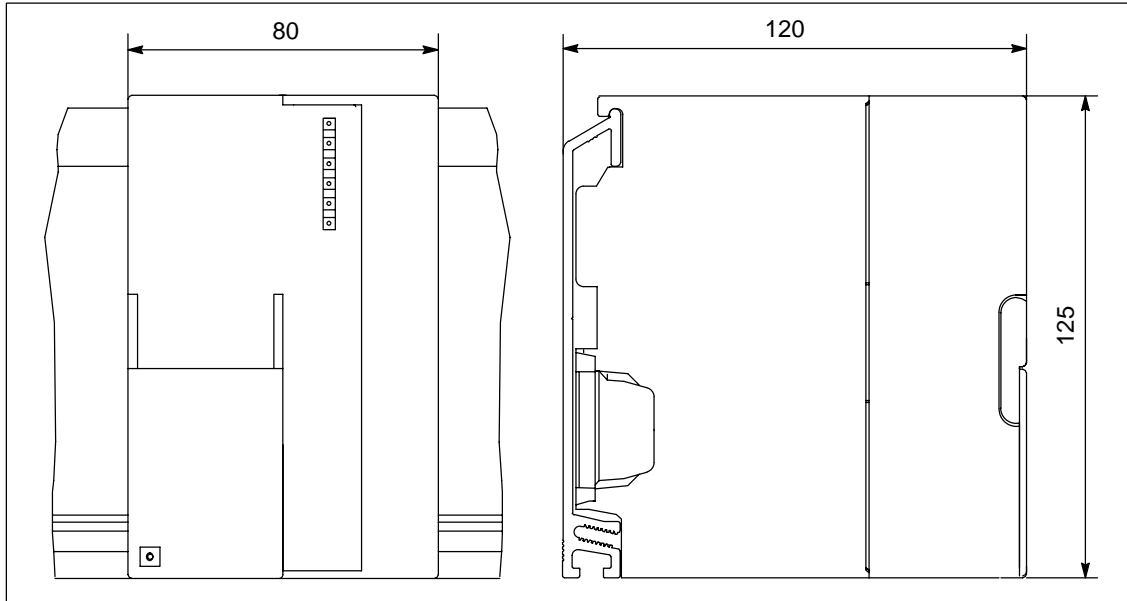

Figure C-18 Interface Module IM 361

IM 365

Figure C-19 shows the dimension drawing of interface module IM 365.

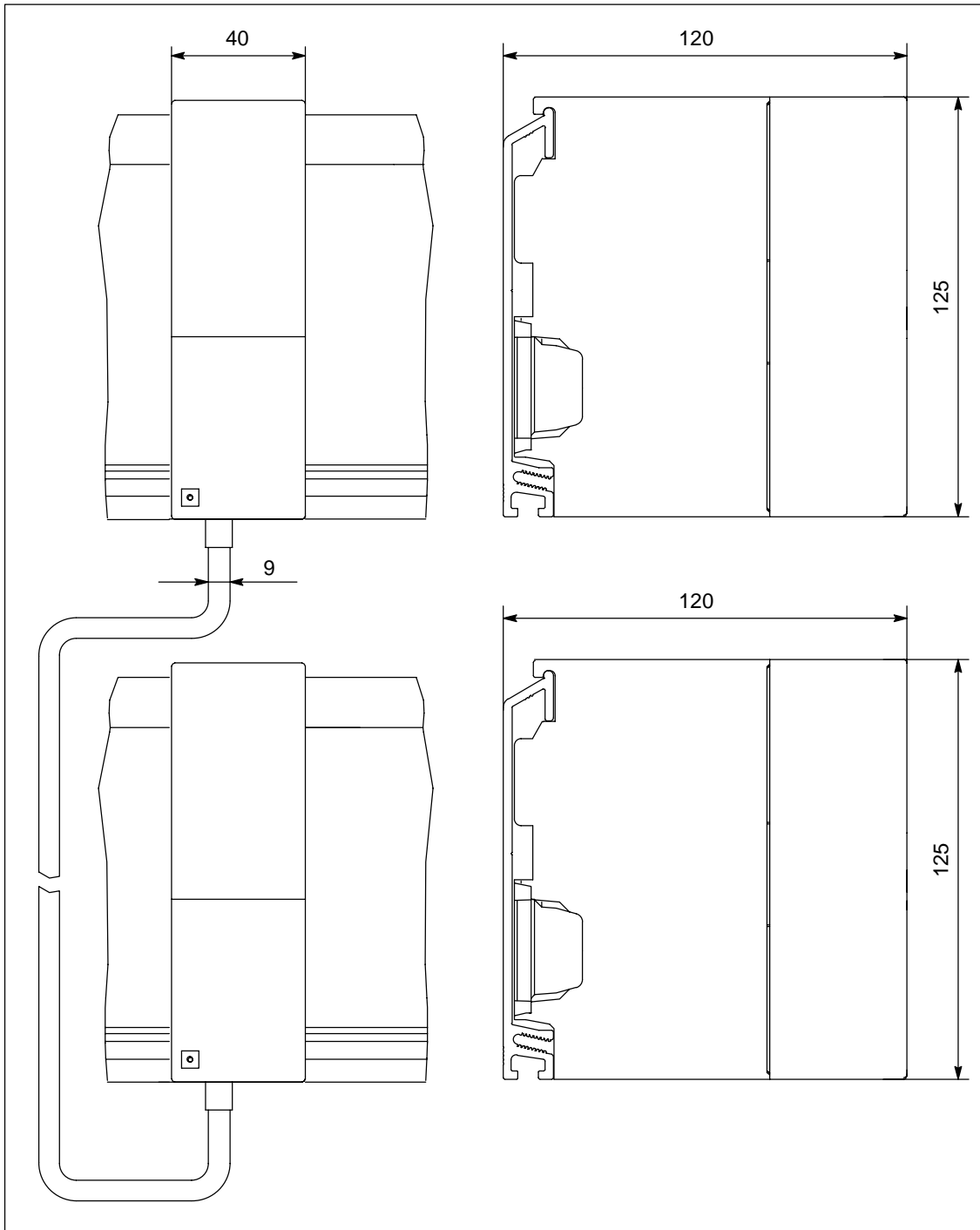

Figure C-19 Interface Module IM 365

C.4 Dimension Drawings of the Signal Modules

Signal module

Figure C-20 shows the dimension drawing of the signal module.

A signal module might look slightly different than the example below. The dimensions however are always the same.

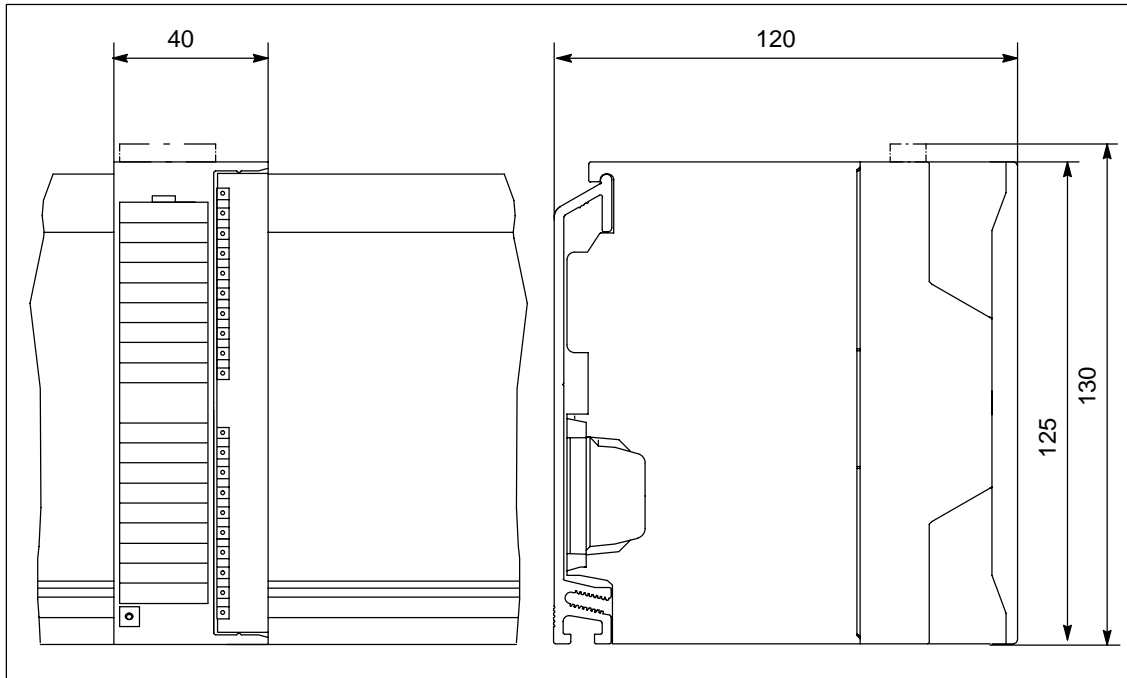

Figure C-20 Signal Module

C.5 Dimension Drawings for Accessories

Shield connecting element

Figure C-21 shows the dimension drawing of the shield connecting element in connection with two signal modules.

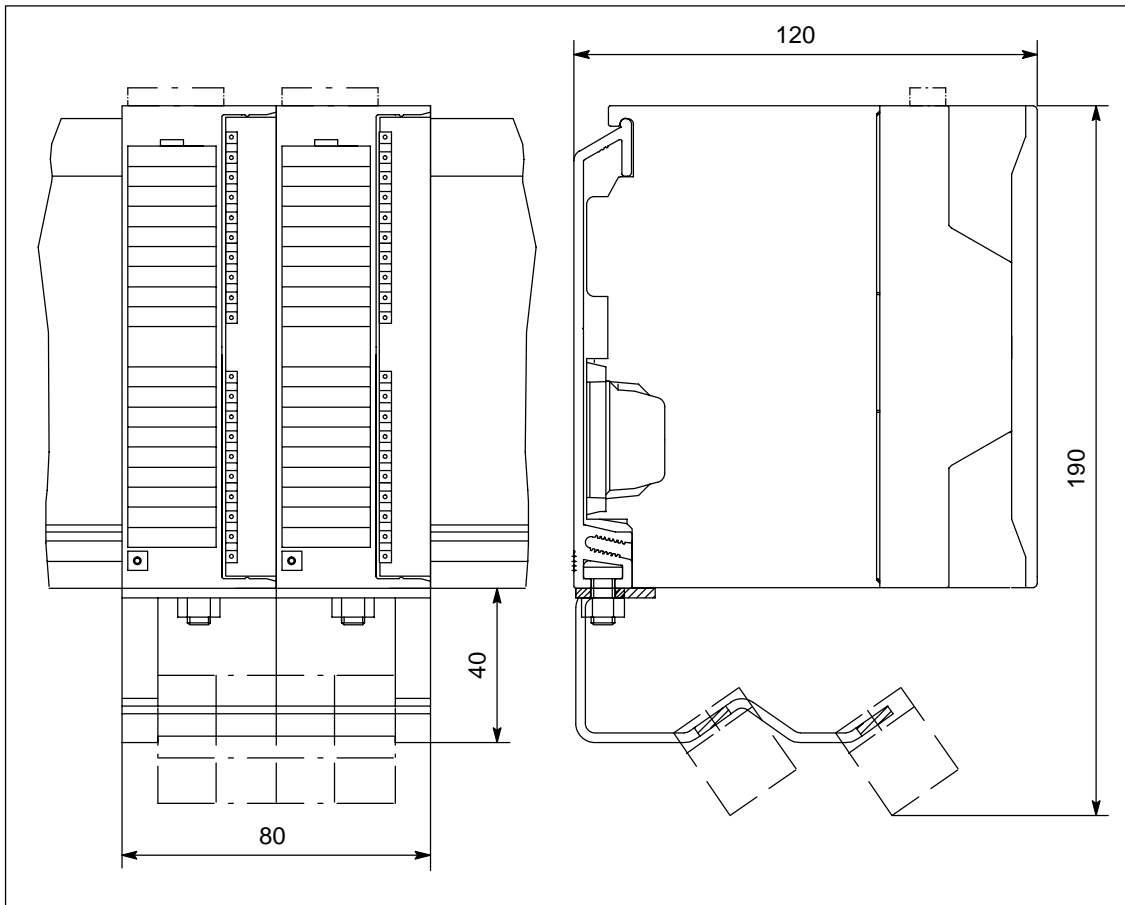

Figure C-21 2 Signal Modules with Shield Connecting Element

SIMATIC TOP connect, 3-tier

Figure C-22 shows the dimension drawing of the 3-tier SIMATIC TOP connect.

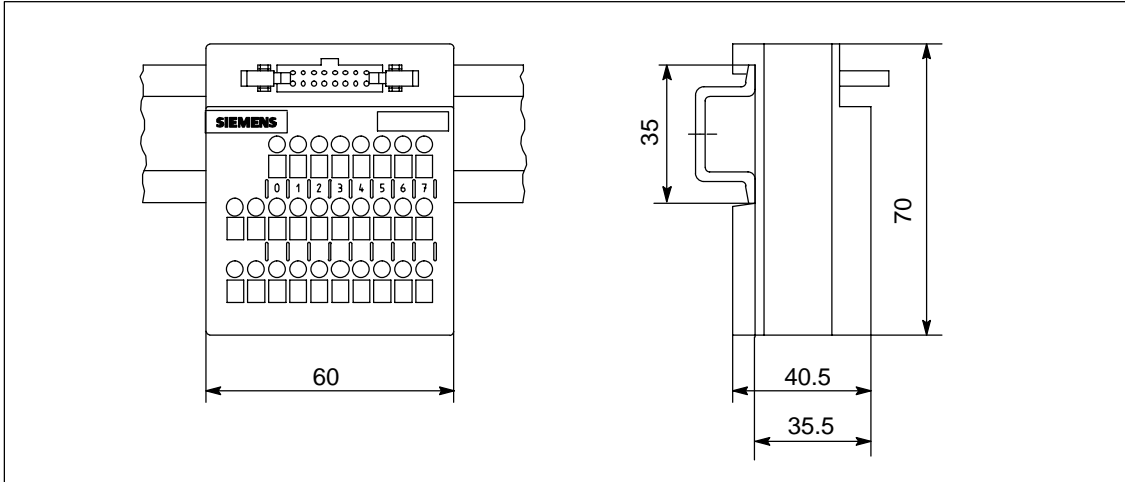

Figure C-22 SIMATIC TOP connect, 3-tier

SIMATIC TOP connect, 2-tier

Figure C-23 shows the dimension drawing of the 2-tier SIMATIC TOP connect.

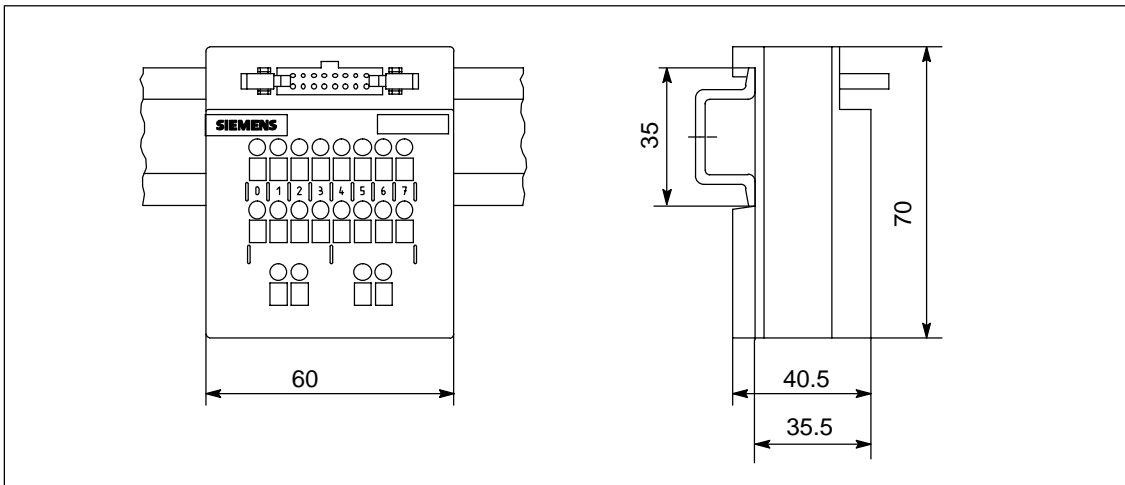

Figure C-23 SIMATIC TOP connect, 2-tier

SIMATIC TOP connect, 1-tier

Figure C-24 shows the dimension drawing of the 1-tier SIMATIC TOP connect.

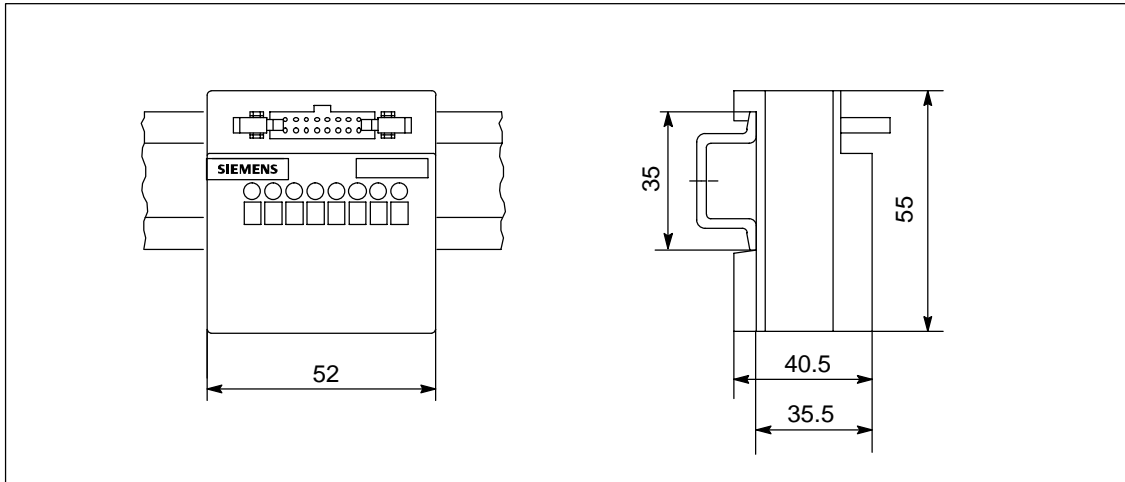

Figure C-24 SIMATIC TOP connect, 1-tier

RS 485 repeater on standard rail

Figure C-25 shows the dimension drawing of the RS 485 repeater on the standard rail.

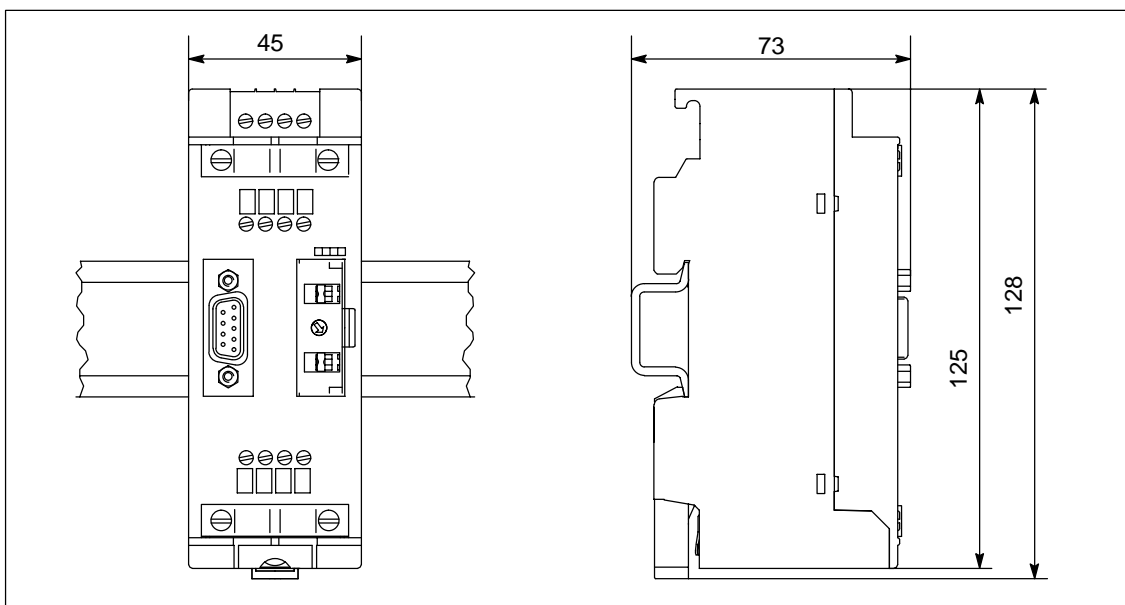

Figure C-25 RS 485 Repeater on Standard Rail

RS 485 repeater on S7-300 rail

Figure C-26 shows the dimension drawing of the RS 485 repeater on the S7-300 rail.

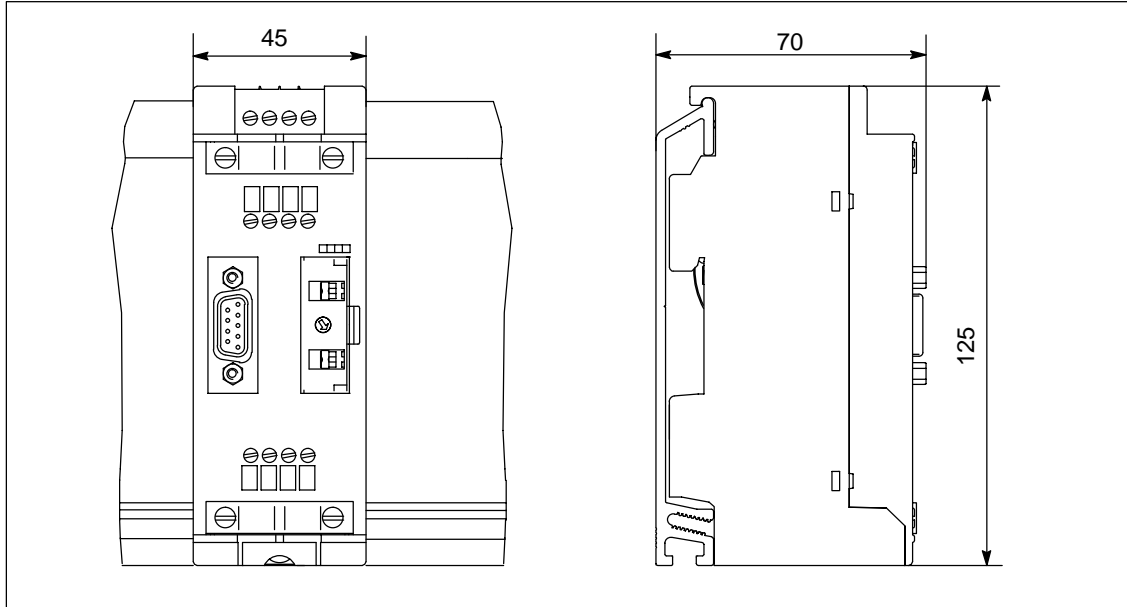

Figure C-26 RS 485 repeater on S7-300 rail

Spare Parts and Accessories for S7-300 Modules

D

Spare parts

Table D-1 lists all the parts you can order separately or later for S7-300 programmable controllers.

Table D-1 Accessories and Spare Parts

S7-300 Parts	Order number
Bus connector	6ES7 390-0AA00-0AA0
Power connector between power supply unit and CPU	6ES7 390-7BA00-0AA0
Labeling strip (Qty 10) <ul style="list-style-type: none"> For 8/16-channel modules For 32-channel modules 	6ES7 392-2XX00-0AA0 6ES7 392-2XX10-0AA0
Labeling strips to be printed <ul style="list-style-type: none"> For 16-channel modules (petrol) 6ES7 392-2AX00-0AA0 (light beige) 6ES7 392-2BX00-0AA0 (yellow) 6ES7 392-2CX00-0AA0 (red) 6ES7 392-2DX00-0AA0 For 32-channel modules (petrol) 6ES7 392-2AX10-0AA0 (light beige) 6ES7 392-2BX10-0AA0 (yellow) 6ES7 392-2CX10-0AA0 (red) 6ES7 392-2DX10-0AA0 Instructions for printing labeling strips with artwork www.siemens.de/automation/csi/product Contribution ID No.: 11978022 	
Slot numbering label	6ES7 912-0AA00-0AA0
Front connector 20-pin <ul style="list-style-type: none"> Screw-type Connection 6ES7 392-1AJ00-0AA0 Spring-loaded Connection 6ES7 392-1BJ00-0AA0 	
Front connector 40-pin <ul style="list-style-type: none"> Screw-type Connection 6ES7 392-1AM00-0AA0 	

Table D-1 Accessories and Spare Parts, Fortsetzung

S7-300 Parts	Order number
Front connector for 2 flat ribbon terminals <ul style="list-style-type: none"> • Screw-type Connection • Spring-loaded Connection 	6ES7 921-3AB00-0AA0 6ES7 921-3AA00-0AA0
Front connector for 4 flat ribbon terminals <ul style="list-style-type: none"> • Spring-loaded Connection 	6ES7 921-3AA20-0AA0
SIMATIC TOP connect, 1-tier, with <ul style="list-style-type: none"> • Screw-type Connection • Spring-loaded Connection 	6ES7 924-0AA00-0AA0 6ES7 924-0AA00-0AB0
SIMATIC TOP connect, 2-tier, with <ul style="list-style-type: none"> • Screw-type Connection • Spring-loaded Connection 	6ES7 924-0BB00-0AA0 6ES7 924-0BB00-0AB0
SIMATIC TOP connect, 3-tier, with <ul style="list-style-type: none"> • Screw-type Connection • Spring-loaded Connection 	6ES7 924-0CA00-0AA0 6ES7 924-0CA00-0AB0
Round-sheath ribbon cable (16-pin) <ul style="list-style-type: none"> • Unshielded 30 m • Unshielded 60 m • Shielded 30 m • Shielded 60 m 	6ES7 923-0CD00-0AA0 6ES7 923-0CG00-0AA0 6ES7 923-0CD00-0BA0 6ES7 923-0CG00-0BA0
Plug-in connectors, 16-pin, set of 8 (insulation displacement connectors)	6ES7 921-3BE10-0AA0
Shield connecting element	6ES7 390-5AA00-0AA0
Shield connection terminals for <ul style="list-style-type: none"> • 2 cables, each with a shield diameter of 2 to 6 mm • 1 cable with a shield diameter of 3 to 8 mm • 1 cable with a shield diameter of 4 to 13 mm 	6ES7 390-5AB00-0AA0 6ES7 390-5BA00-0AA0 6ES7 390-5CA00-0AA0
Measuring range module for analog modules	6ES7 974-0AA00-0AA0
Fuse set for 120/230 VAC digital output modules (contains 10 fuses and 2 fuse carriers)	6ES7 973-1HD00-0AA0
Interconnecting cable between IM 360 and IM 361 or IM 361 and IM 361 <ul style="list-style-type: none"> • 1 m • 2.5 m • 5 m • 10 m 	6ES7 368-3BB01-0AA0 6ES7 368-3BC51-0AA0 6ES7 368-3BF01-0AA0 6ES7 368-3CB01-0AA0

Guidelines for Handling Electrostatic Sensitive Devices (ESD)



Introduction

In this appendix, we explain

- what is meant by "electrostatic sensitive devices"
- the precautions you must observe when handling and working with electrostatic sensitive devices.

Contents

This chapter contains the following sections on electrostatic sensitive devices:

Section	Contents	Page
E.1	What is ESD?	E-2
E.2	Electrostatic Charging of Persons	E-3
E.3	General Protective Measures Against Electrostatic Discharge Damage	E-4

E.1 What is ESD?

Definition

All electronic modules are equipped with large-scale integrated ICs or components. Due to their design, these electronic elements are very sensitive to overvoltages and thus to any electrostatic discharge.

The abbreviation **ESD** has been introduced for these **E**lectrostatic **S**ensitive **D**evices/**M**odules.

Electrostatic sensitive devices are labeled with the following symbol:

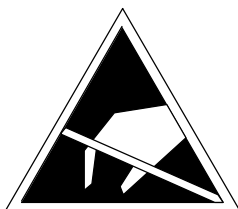

Caution

Electrostatic sensitive devices are subject to voltages that are far below the voltage values that can still be perceived by human beings. These voltages are present if you touch a component or the electrical connections of a module without previously being electrostatically discharged. In most cases, the damage caused by an overvoltage is not immediately noticeable and results in total damage only after a prolonged period of operation.

E.2 Electrostatic Charging of Persons

Charging

Every person with a non-conductive connection to the electrical potential of its surroundings can be charged electrostatically.

Figure E-1 shows you the maximum values for electrostatic voltages which can build up on a person coming into contact with the materials indicated in the figure. These values are in conformity with the specifications of IEC 801-2.

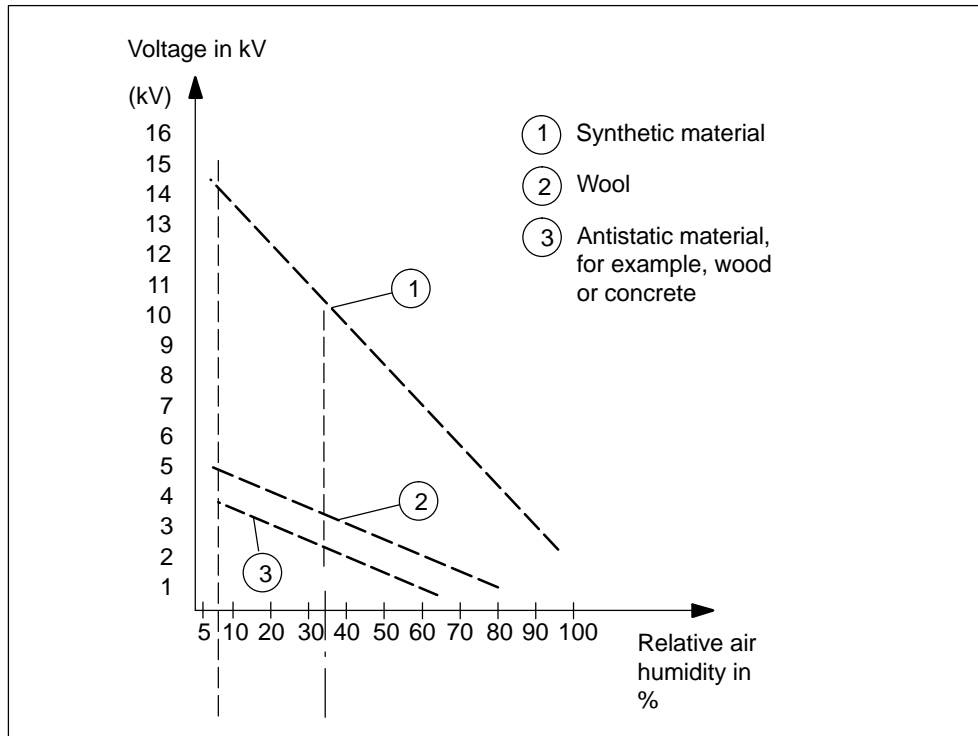

Figure E-1 Electrostatic Voltages which Can Build up on a Person

E.3 General Protective Measures Against Electrostatic Discharge Damage

Ensure sufficient grounding

Make sure that the personnel, working surfaces and packaging are sufficiently grounded when handling electrostatic sensitive devices. You thus avoid electrostatic charging.

Avoid direct contact

You should touch electrostatic sensitive devices only if it is unavoidable (for example, during maintenance work). Hold modules without touching the pins of components or printed conductors. In this way, the discharged energy cannot affect the sensitive devices.

If you have to carry out measurements on a module, you must discharge your body before you start the measurement by touching grounded metallic parts. Use grounded measuring devices only.

F

List of Abbreviations

Abbreviation	Explanation
AC	Alternating current
ADC	Analog-to digital converter
AI	Analog input
AO	Analog output
PLC	Programmable logic controller
COMP	Compensating terminal
CP	Communications processor
CPU	Central processing unit of a PLC
DAC	Digital-to-analog converter
DB	Data block
DC	Direct current
DI	Digital input
DO	Digital output
ESD	Electrostatic sensitive devices
EMC	Electromagnetic compatibility
EPROM	Erasable programmable read-only memory
ES	Encoder supply
EWS	Apply substitute value
FB	Function block
FC	Function
FEPRM	Flash erasable programmable read only memory
I _C	Constant-current lead
L+	Terminal for 24 VDC supply voltage
LWH	Hold last valid value
FOC	Fiber-optic cable
M	Ground terminal
M+	Measuring lead (positive)
M-	Measuring lead (negative)
M _{ANA}	Reference potential of the analog measuring circuit

MPI	Multipoint interface
OB	Organization block
OP	Operator panel
OS	Operator system
PII	Process-image input table
PIQ	Process-image output table
PLC	Programmable logic control
PS	Power supply
Q_I	Analog output current
Q_V	Analog output voltage
RAM	Random access memory
R_L	Load impedance
S +	Detector lead (positive)
S-	Detector lead (negative)
SF	"Group error" error LED
SFB	System function block
SFC	System function
SM	Signal module
SSI	Synchronous serial interface
TD	Text display
U_{CM}	Common mode voltage
U_{iso}	Potential difference between M_{ANA} and local ground

Glossary

Address

An address denotes a specific operand or address area; examples of this are: input I 12.1; memory word MW 25; data block DB 3.

Aggregate current

Sum of the currents of all output channels on a digital output module.

Backplane bus

The backplane bus is a serial data bus that is used by the modules to communicate with each other and to supply them with the voltage they require. The interconnection of the modules is established by the bus connector.

Basic error limit

The basic error limit is the operational limit at 25 °C, referred to the rated range of the analog module.

Bus

A bus is a transmission medium that interconnects several nodes. Data transmission can be serial or parallel, and be performed over electric conductors or fiber-optic cables.

Bus segment

A bus segment is a self-contained section of a serial bus system. Bus segments are interconnected by means of → repeaters.

Common mode voltage

A voltage that is common to all inputs/outputs of a group and is measured between this group and any reference point (usually to ground).

Communication processor

Programmable module for communication tasks, such as networking, point-to-point connection.

Comparison point

When using thermocouples on analog input modules: point of known temperature (for example, → compensating box).

Compensating box

Compensating boxes can be used for measuring temperatures with thermocouples on analog input modules. The compensating box is a compensation circuit for compensating temperature fluctuations at the → Comparison point.

Complete restart

When a CPU starts up (say, when the mode selector switch is moved from STOP to RUN or when the mains supply is turned on), OB 100 (Restart) is processed before cyclic programming processing (OB 1).
With a complete restart, the → Process input image is read in and the *STEP 7* user program is processed, starting with the first instruction in OB1.

Configure

Select and put together different components on a programmable logic controller and install the requisite software and adapt to the specific use (for example, by assigning parameters to the modules).

CP

→ Communications processor

CPU

The CPU (central processing unit) is a CPU module of the → programmable logic controller that stores and runs the user program. It contains the operating system, memory, processing unit and communication interface.

Default setting

The default setting is a sensible basic setting that is used whenever no other value is used.

Destruction limit

Limit of permitted input voltage / input current.
If this limit is exceeded, the measuring accuracy may deteriorate. If the destruction limit is exceeded by a vast amount, this may destroy the internal measuring circuit.

Diagnostic buffer

The diagnostic buffer is a buffered memory area in the CPU which stores the diagnostics events in the order in which they occurred.
For troubleshooting, the user can read out the exact error cause in *STEP 7* (PLC -> Module State) from the diagnostic buffer.

Diagnostic data

All the diagnostics events that occurred are collected in the CPU and entered in the → Diagnostic buffer. If there is an error OB, it is started.

Diagnostic interrupt

Modules with diagnostics capability report system errors by means of diagnostic interrupts to the → CPU. The operating system of the CPU calls OB 82 in the course of a diagnostic interrupt.

Diagnostics

Generic term for → System diagnostics, process error diagnosis and user-defined diagnostics.

Direct access

A direct access is the direct accessing of the CPU by means of the → Backplane bus to modules while avoiding the → Process image.

Encoder absolute

An encoder absolute determines the path traveled during position detection by reading a numerical value. In the case of encoders absolute with a serial interface (SSI), path information is transferred synchronously and serially according to the SSI protocol (synchronous serial interface).

Equipotential bonding

Electrical connection (equipotential bonding conductor), which brings the bodies of electrical resources and foreign conductive bodies to an identical or approximately identical potential in order to avoid interfering or hazardous voltages between these bodies.

FREEZE

Parameter in *STEP 7* for position detection module SM 338; POS-INPUT. The FREEZE function is a control command for freezing current encoder values of the SM 338 to the instantaneous value.

Ground

The conductive ground whose electric potential can be set equal to zero at every point.
In the proximity of grounding electrodes, the ground can have a potential differing from zero. The term "reference ground" is frequently used to describe such circumstances.

Ground, to

To ground means connect an electrically conductive part by means of a grounding system to the grounding electrode (one or more conductive parts having a very good contact to ground).

Hardware interrupt

A hardware interrupt is triggered by interrupt-triggering modules as a result of a certain event in the process (overshooting or undershooting of a limit value; a module has completed the cyclic conversion of its channels).
The hardware interrupt is reported to the CPU. In accordance with the priority of this interrupt, the → Organization block assigned to it is scanned.

Hold last value (LWH)

The module retains the last value read out before STOP mode.

Input delay

Parameter in *STEP 7* for digital input modules. The input delay is used to suppress injected interference. Interfering pulses from 0 ms to the set input delay are suppressed.
The set input delay is subject to a tolerance, which can be taken from the technical specifications of the module. A high input delay suppresses long interfering pulses, whereas a low input delay suppresses short ones.
The permissible input delay depends on the length of the cable between the encoder and the module. For example, a high input delay has to be set for long unshielded supply conductors to the encoder (longer than 100m).

Integration time

Parameter in *STEP 7* for analog input modules. The integration time is the inverse value of the → Interference frequency suppression in ms.

Interface, multipoint

→ MPI

Interference frequency suppression

Parameter in *STEP 7* for analog input modules. The frequency of the AC network can interfere with the measured value, especially with measurements in low voltage ranges and with thermocouples. This parameter is used by the user to specify the prevailing line frequency on his system.

Interrupt

The SIMATIC S7 is familiar with 28 different run-time level, which govern running of the user program. These run-time levels include interrupts such as hardware interrupts, among other things. When an interrupt occurs, the operating system automatically calls an assigned organization block in which the user can program the reaction he wants (for example, in an FB).

Interrupt, diagnostic

→ Diagnostic Interrupt

Interrupt, hardware

→ Hardware interrupt

Interrupt, end-of-scan-cycle interrupt

→ Hardware interrupt

Linearity error

The linearity error identifies the maximum deviation of the measured/output value from the ideal linear relationship between the measuring/output signal and the digital value. The data is a percentage and relates to the rated range of the analog module.

Logic block

In a SIMATIC S7 context, a logic block is a block that contains a part of the *STEP 7* user program. By contrast, a data block only contains data. There are the following logic blocks: organization blocks (OBs), function blocks (FBs), functions (FCs), system function block (SFBs), system functions (SFCs).

Measuring range module

Measuring range modules are plugged into the analog input modules for adaptation to different measuring ranges.

Module filtering mode

By operating mode we mean:

1. The selection of an operating mode of the CPU using the mode switch or the PG
2. The type of program execution in the CPU
3. A parameter in *STEP 7* for analog input modules

Monoflop time

Parameter in *STEP 7* for position detection module SM 338; POS-INPUT. The monoflop time is the time interval between 2 SSI message frames (→ Encoder absolute).

MPI

The multipoint interface (MPI) is the programmer port of the SIMATIC S7. It is used to access programmable modules ((CPUs, CPs), text displays and operator panel from a central point. The nodes on the MPI can communicate with each other.

Non-isolated

In the case of non-isolated input/output modules, the reference potentials of the control and load circuit are electrically connected.

Normalizing

Parameter in *STEP 7* for position detection module SM 338; POS-INPUT. Normalizing right justifies the encoder value of the → encoder absolute; non-relevant places are discarded.

OB

→ Organization block

Operational limit

The operational limit is the measuring or output error of the analog module over the entire temperature range, referred to the rated range of the analog module.

Optically isolated

With optically isolated input/output modules, the reference potentials of the control and load circuit are galvanically isolated; for example, by an optocoupler, contact assembly or repeater. Input/output circuits can be connected to common potential.

Organization block

Organization blocks (OBs) form the interface between the operating system of the CPU and the user program. The order in which the user program is processed is defined in the organization blocks.

Parameters

1. Tag of a → Logic block
 2. Tag for setting the characteristics of a module (one or more per module).
- When delivered to the customer, each module has a practical basic setting for its parameters, which the user can modify in *STEP 7*.

Process image

The signal states of the digital input and output modules are stored in the CPU in process image.

A distinction is made between the process-image of inputs and of outputs. The process input image (PII) is read by the input modules before the operating system scans the user program. The process output image (PIQ) is transferred to the output modules at the end of program scanning.

Product status

Products having an identical order number are distinguished by their product status. The product status is incremented for upwards compatible extensions, modifications due to production reasons (use of new component parts and components) and troubleshooting.

Programming device

A programming device (PG) is a personal computer in a specific industry-standard and compact design. A PG is completely equipped for programming SIMATIC programmable logic controllers.

Reaction to open thermocouple

Parameter in *STEP 7* for analog input modules when using Thermocouples. This parameter defines whether "Overflow" (7FFF_H) or "Underflow" (8000_H) is output by the module in the event of an open thermocouple.

Reference potential

Potential from the point of view of which the voltages of the involved circuits are analyzed and measured.

Repeat accuracy

The repeat accuracy identifies the maximum deviation among the measured/output values that then occurs, when the same input signal is again applied or the same input value specified. The repeat accuracy relates to the rated range of the module and applies to the settled temperature state.

Repeater

Equipment for the amplification of bus signals and connection of → bus segments over long distances.

Resolution

With analog modules, the number of bits which represent the digitized analog value in binary. Resolution depends on the module and with analog input modules on the → integration time. The precision of the resolution of a measured value increases with the length of the integration time. The resolution can be as many as 16 bits, including sign.

Retentivity

Data areas in data blocks, and also timers, counters and memory markers are retentive when their contents are not lost upon a complete restart or POWER DOWN.

Scan time

The scan time is the time required by the → CPU to scan the → user program once.

Segment

→ Bus segment

SFC

→ System function

Signal module

Signal modules (SM) form the interface between the process and the programmable logic controller. There are input modules, output modules, input/output modules (both digital and analog).

Smoothing

Parameter in *STEP 7* for analog input modules. The measured values are smoothed by digital filtering. For specific modules it is possible to choose between no, low, medium and high smoothing. The higher the smoothing, the greater is the time constant of the digital filter.

STARTUP

The STARTUP mode is transversed during the transition from STOP mode to RUN mode. STARTUP can be triggered by the → Mode switch or following power-on or by means of an operator input on the programming device. With the S7-300 and M7-300, a → Complete restart is performed.

Status mode

The SIMATIC S7 programmable logic controllers are familiar with the following of status modes: STOP, → STARTUP, RUN and STOP.

Substitute value

Substitute values are values that can be output to the process when signal output modules have failed or be used in the user program instead of a process value when signal input modules have failed.

The substitute values can be assigned parameters by the user in *STEP 7* (old value retained, substitute value 0 or 1). They are values which the output(s) have to output in the event of a CPU STOP.

System diagnostics

System diagnostics is the detection, analysis and reporting of errors that occur within the programmable logic controller. Examples of such errors are: program errors or failures on modules. System errors can be indicated with LED displays or in *STEP 7*.

System function

A system function (SFC) is a function that is integrated in the operating system of the CPU a function that can be triggered in the *STEP 7* user program, if necessary.

Temperature coefficient

Parameter in *STEP 7* for analog input modules when measuring temperatures with a resistance thermometer (RTD). The temperature coefficient you select depends on the resistance thermometer being used (to DIN standard).

Temperature error

The temperature error identifies the drift of the measured/output value caused by the change in the ambient temperature of the analog module. It is specified as a percentage per Kelvin and relates to the rated range of the analog module.

Temperature errors of internal compensation

The temperature error of internal compensation only occurs during thermocouple measurement. It identifies the additional error which is to be taken into account and added to the actual temperature error when "internal comparison" mode is selected. The data is either given as a percentage relative to the physical rated range of the analog module or as an absolute value in °C.

Two-conductor/three-conductor/four-conductor connection

Method of connection to the module – for example, of resistance thermometers/resistors to the front connector of the analog input module or of loads at the voltage output of an analog output module.

Two-wire transmitter/four-wire transmitter

Kind of transmitter (two-wire transmitter: supply (via terminals of the analog input module; 4-wire transmitter: supply via separate terminals of the transmitter)

Ungrounded

Without galvanic connection to ground

User program

The user program contains all the statements, tags and data for signal processing used to control a system or a process. It is assigned to a programmable module (CPU, FM, for example) and can be structured in smaller units (blocks).

Wire-break

Parameter in *STEP 7*. A wire-break test is used for monitoring the connection from the input to the encoder and from the output to the actuator. With wire-break, the module detects a flow of current at the appropriately parameterized input/output.

Index

A

- Accessories, D-1
- Active bus module, dimension drawing, C-8
- Actuator connection, to analog output module, 4-72
- Address, Glossary-1
- Addressing, SM 338; POS-INPUT, 5-16
- Aggregate current, Glossary-1
- Ambient conditions, mechanical, 1-10, 1-16
- Analog functions, STEP 7 blocks, 4-1
- Analog input module
 - causes of errors and remedies, 4-79
 - common-mode error, 4-79
 - configuring error, 4-79
 - connecting resistance thermometers, 4-57
 - connecting resistors, 4-57
 - connecting sensor, 4-49
 - connecting thermocouple, 4-63
 - diagnostic interrupt, 4-44
 - diagnostic message in measured value, 4-78
 - diagnostic messages, 4-78
 - diagnostics, 4-44
 - group diagnostics, 4-44
 - interference frequency suppression, 4-46, A-9
 - isolated, 4-49
 - limit value, 4-44
 - load voltage missing, 4-79
 - measurement, 4-45
 - measuring method, 4-45
 - measuring methods and measuring ranges, A-9
 - measuring range, 4-45
 - module filtering mode, 4-45
 - non-isolated, 4-49
 - overflow, 4-80
 - parameter assignment error, 4-79
 - parameters, 4-44, A-7
 - potential difference, 4-49
 - reaction with open thermocouple, 4-45
- Analog input module
 - SM 331; AI 2 x 12 bits, 4-150
 - SM 331; AI 8 x 12 bits, 4-111
 - SM 331; AI 8 x 13 bits, 4-105
 - SM 331; AI 8 x 16 bits, 4-83, 4-92
 - SM 331; AI 8 x RTD, 4-122
 - SM 331; AI 8 x TC, 4-135
 - smoothing of analog input values, 4-46
 - structure of data record 1, A-8
 - temperature coefficient, 4-46
 - temperature unit, 4-45
 - underflow, 4-80
 - wire-break, 4-79, 4-80
 - wire-break check, 4-44
- Analog input modules, SM 331, channel-specific diagnostic data, B-6
- Analog input/module, structure of data record 1, A-41
- Analog input/output module
 - integration time, 4-48
 - measurement, 4-48
 - measuring method, 4-48
 - measuring range, 4-48
 - output range, 4-48
 - output type, 4-48
 - parameters, 4-48, A-40
 - SM 332; AO 2 x 12 bits, 4-177
 - SM 334; AI 4/AO 2 x 12 bits, 4-189
 - SM 334; AI 4/AO 2 x 8/8 bits, 4-183
- Analog module
 - assigning parameters, 4-43
 - behavior, 4-34
 - determination of measuring error/output error, 4-38
 - diagnostics, 4-77
 - dimension drawing, C-17
 - group error LED, 4-78
 - interrupts, 4-81
 - sequence of steps for commissioning, 4-8
 - SF LED, 4-78
 - supply voltage failure, 4-35

- Analog output channel, conversion time, 4-41
 - Analog output module
 - causes of errors and remedies, 4-80
 - connecting loads and actuators, 4-72
 - connecting loads to current output, 4-76
 - connecting loads to voltage output, 4-73
 - diagnostic interrupt, 4-47
 - diagnostic messages, 4-79
 - diagnostics, 4-47
 - group diagnostics, 4-47
 - isolated, 4-72
 - load voltage missing, 4-80
 - M short-circuit, 4-80
 - non-isolated, 4-72
 - output methods and output ranges, A-37
 - output range, 4-47
 - output type, 4-47
 - parameter assignment error, 4-80
 - parameters, 4-47
 - response time, 4-42
 - response with CPU-STOP, 4-47
 - setting substitute values, A-37
 - settling time, 4-42
 - SM 332; AO 4 x 12 bits, 4-171
 - SM 332; AO 4 x 16 bits, 4-166
 - SM 332; AO 8 x 12 bits, 4-160
 - structure of data record 1, A-36
 - Analog output modules, parameters, A-35
 - Analog output modules, SM 332,
 - channel-specific diagnostic data, B-6
 - Analog value
 - conversion, 4-10
 - sign, 4-10
 - Analog value representation, 4-10
 - binary representation of input ranges, 4-13
 - binary representation of output ranges, 4-26
 - for current measuring ranges, 4-16–4-18
 - for current output ranges, 4-30–4-33
 - for resistance type transmitters, 4-17
 - for RTD Resistance Temperature Detectors,
 - 4-17, 4-18, 4-19, 4-20, 4-21, 4-22, 4-23, 4-24, 4-25
 - for RTD resistance temperature detectors,
 - 4-19, 4-20
 - for voltage measuring ranges, 4-14–4-16
 - for voltage output ranges, 4-28–4-31
 - Analog-to-digital conversion, 4-39
 - Approval
 - CE, 1-2
 - CSA, 1-3
 - FM, 1-4
 - Shipbuilding, 1-4
 - UL, 1-3
 - Approvals, Standards, 1-2
 - Auxiliary voltage missing, SM 338;
 - POS-INPUT, 5-20
- ## B
- Backplane bus, Glossary-1
 - Backup battery, 1-9
 - shipping and storage conditions, 1-8
 - Basic error limit, 4-38
 - Basic knowledge, iii
 - Battery. *See* backup battery
 - Behavior, SM 321; DI 16 x 24 VDC, 3-28
 - Bus segment, Glossary-1
 - Bytes 0 and 1
 - of diagnostic data, B-2
 - of diagnostic data for SM 338; POS-INPUT, B-7
 - Bytes 2 and 3, of diagnostic data, B-3
 - Bytes 2 to 7, of diagnostic data for SM 338;
 - POS-INPUT, B-8
 - Bytes 4 to 7, of diagnostic data, B-4
 - Bytes 8 to 10, of diagnostic data for SM 338;
 - POS-INPUT, B-8

C

Cables, for analog signals, 4-49, 4-72

Causes of error and remedial measures
 SM 321; DI 16 x 24 VDC, 3-30
 SM 322; DO 8 x 24 VDC/0.5 A, 3-78

Causes of errors and remedies
 analog input module, 4-79
 analog output module, 4-80

CE, Approval, 1-2

Changes, in manual, iii

Channel error, SM 338; POS-INPUT, 5-20

Channel information present, SM 338;
 POS-INPUT, 5-20

Channel-specific diagnostics, B-5

Climatic conditions, 1-11

Code type, SM 338; POS-INPUT, 5-15

Commissioning analog modules, sequence of
 steps, 4-8

Commissioning digital modules, sequence of
 steps, 3-10

Common mode voltage, Glossary-1

Common-mode error, analog input module,
 4-79

Communication processor, Glossary-1

Comparison point, 4-67, Glossary-2

Compensating box, 4-65
 connecting, 4-66

Compensation
 external, 4-65
 internal, 4-64, 4-66

Complete restart, Glossary-2

Configuration error, SM 338; POS-INPUT, 5-20

Configure, Glossary-2

Configuring error, analog input module, 4-79

Conversion time
 analog input channels, 4-39
 analog output channel, 4-41

Converting, analog values, 4-10

CP, Glossary-1

CPU, Glossary-2

CSA, Approval, 1-3

Current sensors, connecting, 4-55

D

Data record, for diagnostic data, B-1

Data record 1
 analog input module configuration, A-8
 analog output module configuration, A-36
 digital input module configuration, A-4
 digital output module configuration, A-6
 structure for SM 331; AI 8 x 13 bits, A-27
 structure for SM 331; AI 8 x RTD, A-12
 structure for SM 331; AI 8 x TC, A-20
 structure of analog input/output module,
 A-41

Data record 128
 structure for SM 331; AI 8 x RTD, A-13
 structure for SM 331; AI 8 x TC, A-21

Data record1, Configuration SM 332; AO 8 x
 12 bits, A-39

Data records, for parameters, A-2

Default setting, Glossary-2

Degree of protection, 1-12
 IP 20, 1-12

Destruction limit, Glossary-2

Diagnostic buffer, Glossary-3

Diagnostic data, Glossary-3
 bytes 0 and 1, B-2
 bytes 2 and 3, B-3
 bytes 4 to 7, B-4
 channel-specific, B-5
 channel-specific, for analog input modules
 of SM 331, B-6
 channel-specific, for analog output modules
 of SM 332, B-6
 channel-specific, for SM 321; DI 16 x 24
 VDC, B-5
 channel-specific, for SM 322; DO 8 x 24
 VDC/0.5 A, B-5
 channel-specific, for SM 338; POS-INPUT,
 B-8
 data record, B-1
 SM 338; POS-INPUT, B-7

Diagnostic data for SM 338; POS-INPUT,
 bytes 0 and 1, B-7

Diagnostic data of SM 338; POS-INPUT
 Bytes 2 to 7, B-8
 Bytes 8 to 10, B-8

Diagnostic interrupt
 analog input module, 4-44
 analog output module, 4-47
 of analog modules, 4-81
 SM 321; DI 16 x 24 VDC, 3-26, 3-31
 SM 322; DO 8 x 24 VDC/0.5 A, 3-75, 3-79
 SM 338; POS-INPUT, 5-21

- Diagnostic interrupt enable, SM 338;
 POS-INPUT, 5-14
- Diagnostic messages, 3-12, 4-77, 5-18
 - of analog input modules, 4-78
 - of analog output modules, 4-79
 - reading out, 3-13, 4-78, 5-18
 - SM 322; DO 8 x 24 VDC/0.5 A, 3-77
- Diagnostics
 - analog input module, 4-44
 - analog output module, 4-47
 - of analog modules, 4-77
 - of digital modules, 3-12
 - SM 321; DI 16 x 24 VDC, 3-26, 3-28
 - SM 338; POS-INPUT, 5-18, 5-19
 - system, Glossary-9
- Diagnostics entry, 4-36
- Digital input module
 - SM 321; DI 16 x 24 VDC, 3-18
 - SM 321; DI 16 x 24 VDC High Speed, 3-21
 - SM 321; DI 16 x 24 VDC; source input,
 3-33
 - SM 321; DI 16 x 24 VDC; with hardware
 and diagnostic interrupts, 3-23
 - SM 321; DI 16 x 48-125 VDC, 3-37
 - SM 321; DI 16 x AC 120/230 V, 3-39
 - SM 321; DI 16 x UC 24/48 V, 3-35
 - SM 321; DI 32 x 120 VAC, 3-16
 - SM 321; DI 32 x 120/230 VAC ISOL, 3-43
 - SM 321; DI 32 x 24 VDC, 3-13
 - SM 321; DI 8 x 120/230 VAC, 3-41
 - structure of data record 1, A-4
- Digital input modules, parameters, A-3
- Digital input/output module
 - SM 323; DI 16/DO 16 x 24 VDC/0.5 A,
 3-110
 - SM 323; DI 8/DO 8 x 24 VDC/0.5 A, 3-114
- Digital module
 - assigning parameters, 3-11
 - diagnostics, 3-12
 - dimension drawing, C-17
 - group error LED, 3-13
 - sequence of steps for commissioning, 3-10
 - SF LED, 3-13
- Digital output module
 - parameters, A-5
 - SM 322; DO 16 x 120/230 VAC/1 A, 3-64
 - SM 322; DO 16 x 24 VDC/0.5 A, 3-52
 - SM 322; DO 16 x 24 VDC/0.5 A High
 Speed, 3-55
 - SM 322; DO 16 x 24/48 VUC, 3-58
 - SM 322; DO 32 x 120 VAC/1.0 A, 3-48
 - SM 322; DO 32 x 120/230 VAC/2 A ISOL ,
 3-86
 - SM 322; DO 32 x 24 VDC/0.5 A, 3-45
 - SM 322; DO 8 x 120/230 VAC/2 A, 3-83
 - SM 322; DO 8 x 24 VDC/0.5 A with
 diagnostic interrupt, 3-70
 - SM 322; DO 8 x 24 VDC/2 A, 3-67
 - SM 322; DO 8 x 48-125 VDC/1.5 A, 3-80
 - structure of data record 1, A-6
- Dimension drawing, active bus module, C-8
- Dimension drawings, C-1
 - analog module, C-17
 - digital module, C-17
 - IM 361, C-14
 - interface module, C-14
 - power supply module PS 307, C-9
 - PS 307, C-9
 - rail, C-2
 - RS 485 repeater, C-20
 - shield connecting element, C-18
 - signal module, C-17
 - SIMATIC TOP connect, C-19
- Direct access, Glossary-3
- Documentation package, v
- Dummy module, DM 370, 5-5

E

Electromagnetic compatibility, 1-6
 Encoder absolute, Glossary-3
 Encoder absolute (SSI), SM 338; POS-INPUT, 5-14
 Encoder error, SM 338; POS-INPUT, 5-20
 Encoder value detection, clocked, 5-11
 Environmental conditions, 1-9
 extended, 1-14
 Outdoor modules, 1-16
 EPROM error
 SM 321; DI 16 x 24 VDC, 3-30
 SM 322; DO 8 x 24 VDC/0.5 A, 3-78
 Equipotential bonding, Glossary-3
 Error, of an analog module, 4-38
 Error causes and troubleshooting, SM 338; POS-INPUT, 5-20
 Extended environmental conditions, 1-14
 External auxiliary voltage missing, SM 321; DI 16 x 24 VDC, 3-30

F

FM, Approval, 1-4
 Four-conductor connection, 4-58, Glossary-10
 Four-wire transmitter, Glossary-10
 Four-wire transmitters, 4-57
 FREEZE, Glossary-3
 Freeze function, SM 338; POS-INPUT, 5-13, 5-15
 Fuse blown
 SM 321; DI 16 x 24 VDC, 3-30
 SM 322; DO 8 x 24 VDC/0.5 A, 3-78

G

Ground, Glossary-4
 Grounded operation, RS 485 repeater, 7-4
 Group diagnostics
 analog input module, 4-44
 analog output module, 4-47
 Group error LED
 analog module, 4-78
 digital module, 3-13
 SM 338; POS-INPUT, 5-18

H

Hardware interrupt, Glossary-4
 End of scan cycle, 4-83
 SM 321; DI 16 x 24 VDC, 3-26, 3-32
 when limit exceeded, 4-82
 Hardware interrupt lost, SM 321; DI 16 x 24 VDC, 3-30, 3-32
 Hold last value, SM 322; DO 8 x 24 VDC/0.5 A, 3-75

I

Identifiers for Australia, 1-4
 IEC 61131, 1-4
 IM 360
 dimension drawing, C-14
 interface module, 6-3
 IM 361, interface module, 6-5
 IM 365
 dimension drawing, C-16
 interface module, 6-7
 Input delay, Glossary-4
 SM 321; DI 16 x 24 VDC, 3-26
 Insulation test, 1-12
 Integration time, Glossary-4
 analog input/output module, 4-48
 Interface module, 6-1
 dimension drawing, C-14
 IM 360, 6-3
 IM 361, 6-5
 IM 365, 6-7
 Interference
 pulse-shaped, 1-6
 sinusoidal, 1-7
 Interference frequency suppression, Glossary-5
 analog input module, 4-46, A-9
 SM 331; AI 8 x RTD, A-16
 SM 331; AI 8 x TC, A-24, A-28
 Internal auxiliary voltage missing, SM 321; DI 16 x 24 VDC, 3-30
 Internal compensation, Temperature error, Glossary-10
 Internal error, SM 338; POS-INPUT, 5-20
 Interrupt, Glossary-5

- Interrupt-triggering channels, SM 321; DI 16 x 24 VDC, 3-32
- Interrupts
 - enabling, 3-31, 3-79, 4-81, 5-21
 - of analog modules, 4-81
 - SM 321; DI 16 x 24 VDC, 3-31
 - SM 322; DO 8 x 24 VDC/0.5 A, 3-79
 - SM 338; POS-INPUT, 5-21
- IP 20, 1-12
- Isochrone mode, SM 338, 5-9
- Isolated measuring sensors, 4-50
 - connecting, 4-50

- L**
- Lack of encoder supply, SM 321; DI 16 x 24 VDC, 3-30
- Limit value, analog input module, 4-44
- Linearity error, Glossary-5
- Load connection, to analog output module, 4-72
- Load connection to current output, to analog output module, 4-76
- Load connection to voltage output, to analog output module, 4-73
- Load voltage missing
 - analog input module, 4-79
 - analog output module, 4-80
- Logic block, Glossary-5
- LWH, Glossary-4

- M**
- M short-circuit, analog output module, 4-80
- Manual, purpose, iii
- Manual changes, iii
- Manual package, v
- Measurement
 - analog input module, 4-45
 - analog input/output module, 4-48
- Measuring method
 - analog input channels, 4-31
 - analog input module, 4-45, A-9
 - analog input/output module, 4-48
 - SM 331; AI 8 x 13 bits, A-28
 - SM 331; AI 8 x RTD, A-16
 - SM 331; AI 8 x TC, A-25
- Measuring range
 - analog input channels, 4-31
 - analog input module, 4-45, A-9
 - analog input/output module, 4-48
 - SM 331; AI 8 x 13 bits, A-28
 - SM 331; AI 8 x RTD, A-16
 - SM 331; AI 8 x TC, A-25
- Measuring range module, 4-31
 - replugging, 4-32
- Measuring sensors, isolated, 4-50
- Module Classes, ID, B-2
- Module filtering mode, Glossary-6
 - analog input module, 4-45
- Module malfunction, SM 338; POS-INPUT, 5-20
- Module overview, 4-3
 - digital modules, 3-4
 - other signal modules, 5-2
 - SIMATIC TOP connect/...TPA, 8-2
- Modules, shipping and storage conditions, 1-8
- Monoflop time, Glossary-6
 - SM 338; POS-INPUT, 5-15
- MPI, Glossary-6

- N**
- Navigation, through the manual, vi
- No external auxiliary voltage, SM 322; DO 8 x 24 VDC/0.5 A, 3-78
- No internal auxiliary voltage, SM 322; DO 8 x 24 VDC/0.5 A, 3-78
- No load voltage L+, SM 322; DO 8 x 24 VDC/0.5 A, 3-75, 3-78
- Non-isolated, Glossary-6
- Non-isolated sensors, 4-52
 - connecting, 4-52
- Normalizing, Glossary-6
 - SM 338; POS-INPUT, 5-12, 5-15

O

- OB, Glossary-7
- OB 40, 3-32, 4-82
 - start information, 4-82
- OB 82, 3-31, 3-79, 4-81
- Operating conditions, 1-9
- Operating mode
 - of CPU, 4-34
 - SM 331; AI 8 x RTD, A-16
 - SM 331; AI 8 x TC, A-24
- Operational limit, 4-38, Glossary-6
- Optically isolated, Glossary-6
- Order Number
 - 6ES7 338-4BC01-0AB0, 5-8
 - 6ES7 370-0AA01-0AA0, 5-5
 - 6ES7 374-2XH01-0AA0, 5-3
- Order number
 - 6ES7 305-1BA80-0AA0, 2-2
 - 6ES7 307-1BA00-0AA0, 2-6
 - 6ES7 307-1EA00-0AA0, 2-10
 - 6ES7 307-1EA80-0AA0, 2-10
 - 6ES7 307-1KA00-0AA0, 2-15
 - 6ES7 321-1BH02-0AA0, 3-18
 - 6ES7 321-1BH10-0AA0, 3-21
 - 6ES7 321-1BH50-0AA0, 3-33
 - 6ES7 321-1BH82-0AA0, 3-18
 - 6ES7 321-1BL00-0AA0, 3-13
 - 6ES7 321-1BL80-0AA0, 3-13
 - 6ES7 321-1CH00-0AA0, 3-35
 - 6ES7 321-1CH80-0AA0, 3-37
 - 6ES7 321-1EL00-0AA0, 3-16
 - 6ES7 321-1FF01-0AA0, 3-41
 - 6ES7 321-1FF10-0AA0, 3-43
 - 6ES7 321-1FF81-0AA0, 3-41
 - 6ES7 321-1FH00-0AA0, 3-39
 - 6ES7 321-7BH00-0AB0, 3-23
 - 6ES7 321-7BH80-0AB0, 3-23
 - 6ES7 322-1BF01-0AA0, 3-67
 - 6ES7 322-1BH01-0AA0, 3-52
 - 6ES7 322-1BH10-0AA0, 3-55
 - 6ES7 322-1BH81-0AA0, 3-52
 - 6ES7 322-1BL00-0AA0, 3-45
 - 6ES7 322-1CF80-0AA0, 3-80
 - 6ES7 322-1EL00-0AA0, 3-48
 - 6ES7 322-1FF01-0AA0, 3-83
 - 6ES7 322-1FF81-0AA0, 3-83
 - 6ES7 322-1FH00-0AA0, 3-64
 - 6ES7 322-1HF01-0AA0, 3-95
 - 6ES7 322-1HF10-0AA0, 3-105
 - 6ES7 322-1HF80-0AA0, 3-105
 - 6ES7 322-1HH01-0AA0, 3-92
 - 6ES7 322-5FF00-0AB0, 3-86
 - 6ES7 322-5GH00-0AB0, 3-58
 - 6ES7 322-5HF00-0AB0, 3-98
 - 6ES7 322-8BF00-0AB0, 3-70
 - 6ES7 322-8BF80-0AA0, 3-70
 - 6ES7 323-1BH01-0AA0, 3-114
 - 6ES7 323-1BH81-0AA0, 3-114
 - 6ES7 323-1BL00-0AA0, 3-110
 - 6ES7 331-1KF00-0AB0, 4-105
 - 6ES7 331-7KB02-0AB0, 4-150
 - 6ES7 331-7KB82-0AB0, 4-150
 - 6ES7 331-7KF02-0AB0, 4-111
 - 6ES7 331-7NF00-0AB0, 4-83
 - 6ES7 331-7NF10-0AB0, 4-92
 - 6ES7 331-7PF00-0AB0, 4-122
 - 6ES7 331-7PF10-0AB0, 4-135
 - 6ES7 332-5HB01-0AB0, 4-177
 - 6ES7 332-5HB81-0AB0, 4-177
 - 6ES7 332-5HD01-0AB0, 4-171
 - 6ES7 332-5HF00-0AB0, 4-160
 - 6ES7 332-7ND01-0AB0, 4-166
 - 6ES7 334-0CE01-0AA0, 4-183
 - 6ES7 334-0KE00-0AB0, 4-189
 - 6ES7 360-3AA01-0AA0, 6-3
 - 6ES7 361 3CA01-0AA0, 6-5
 - 6ES7 365-0BA01-0AA0, 6-7
 - 6ES7 972-0AA01-0XA0, 7-2
- Organization block (OB), Glossary-7
- Outdoor modules, 1-14
- Output analog values, STEP 7 blocks, 4-1
- Output method, analog output module, A-37
- Output range
 - analog input/output module, 4-48
 - analog output module, 4-47, A-37
- Output type
 - analog input/output module, 4-48
 - analog output module, 4-47
- Overflow, analog input module, 4-80

P

Parameter assignment
for analog modules, 4-43
for digital modules, 3-11
in user program, A-1

Parameter assignment error
analog input module, 4-79
analog output module, 4-80

Parameterization error, SM 338; POS-INPUT, 5-20

Parameterization missing, SM 338; POS-INPUT, 5-20

Parameters, Glossary-7
analog input module, 4-44, A-7
analog input/output module, 4-48, A-40
analog output module, 4-47
analog output modules, A-35
data records, A-2
digital input modules, A-3
digital output module, A-5
dynamic, 3-11, 4-43
modifying in user program, 3-11, 4-43
SM 321; DI 16 x 24 VDC, 3-26
SM 322; DO 8 x 24 VDC/0.5 A, 3-75
SM 331; AI 8 x RTD, A-11
SM 331; AI 8 x TC, A-19
SM 332; AO 8 x 12 bits, A-38
SM 338; POS-INPUT, 5-14
static, 3-11, 4-43

Parameters, wrong
SM 321; DI 16 x 24 VDC, 3-30
SM 338; POS-INPUT, 5-20

PARAM_MOD, SFC 57, A-2

Pin assignment, RS 485 repeater, 7-7

POS input module SM 338, 5-8

Position detection module, SM 338; POS-INPUT, 5-8

Potential difference, with analog input modules, 4-49

Power supply module, 2-1
dimension drawing, C-9
PS 305 2 A, 2-2
PS 307 10 A, 2-15
PS 307 2 A, 2-6
PS 307 5 A, 2-10

Process image, Glossary-7

Product status, Glossary-7

Programming device (PG), Glossary-7

Protection class, 1-12

PS 307, dimension drawing, C-9

Pulse edge, 3-26

Pulse-shaped interference, 1-6

R

Radio interference, emission of, 1-7

Rail for the "Insert and Remove" function, dimension drawing, C-7

Rails, dimension drawing, C-2

RAM error
SM 321; DI 16 x 24 VDC, 3-30
SM 322; DO 8 x 24 VDC/0.5 A, 3-78

Rated voltages, 1-13

Reaction to open thermocouple, SM 331; AI 8 x TC, A-26

Read analog values, STEP 7 blocks, 4-1

Reference junction temperature with thermocouples, compensating, 4-64

Reference potential, Glossary-7

Relay output module
SM 322; DO 16 x Rel. 120/230 VAC, 3-92
SM 322; DO 8 x Rel. 230 VAC, 3-95
SM 322; DO 8 x Rel. 230 VAC/5 A, 3-105
SM 322; DO 8 x Rel. 230 VAC/5A, 3-98

Repeat accuracy, Glossary-8

Repeater, Glossary-8
See also RS 485-Repeater

Resistance thermometer connection, to analog input module, 4-57

Resistor connection, to analog input module, 4-57

Resolution, 4-10, Glossary-8

Response time, 4-42

Response with CPU-STOP, analog output module, 4-47

Retentivity, Glossary-8

RS 485 repeater
Appearance, 7-3
application, 7-2
definition, 7-2
dimension drawing, C-20
grounded operation, 7-4
rules, 7-2
ungrounded operation, 7-4

RS 485-Repeater, 7-1
grounded, 7-4
ungrounded, 7-4

S

- Scan time, Glossary-8
 - analog input channels, 4-39
 - analog output channels, 4-41
- Screw-type terminals, SIMATIC TOP
 - connect/...TPA, 8-10
- Sensor connection, to analog input module, 4-49
- Sensors, non-isolated, 4-52
- Settling time, 4-42
- SF LED
 - analog module, 4-78
 - digital module, 3-13
 - SM 338; POS-INPUT, 5-18
- SFC, Glossary-8, Glossary-9
- SFC 51, 3-31, 3-79, 4-81
- SFC 55 WR_PARM, A-2
- SFC 56 WR_DPARM, A-2
- SFC 57 PARM_MOD, A-2
- SFC 59, 3-31, 3-79, 4-81
- Shield connecting element, dimension drawing, C-18
- Shipbuilding, Approval, 1-4
- Short-circuit to L+, SM 322; DO 8 x 24 VDC/0.5 A, 3-75, 3-78
- Short-circuit to M, SM 322; DO 8 x 24 VDC/0.5 A, 3-75, 3-78
- Sign, analog value, 4-10
- Signal module, Glossary-8
 - dimension drawing, C-17
- SIMATIC Outdoor modules, 1-14
- SIMATIC TOP connect
 - components, 8-12
 - connection for 2A modules, 8-18
 - dimension drawing, C-19
 - one-conductor connection, 8-14
 - selecting components, 8-13
 - three-conductor connection, 8-16
 - wiring 32-channel digital modules, 8-8
- SIMATIC TOP connect TPA
 - component selection, 8-20
 - connection example, 8-24
 - multiplier terminal, 8-21
 - shield connection, 8-23
 - terminal allocation to analog module, 8-22
 - terminal assignment, 8-21
- SIMATIC TOP connect/...TPA
 - advantages of using, 8-3
 - components, 8-3
 - configuration, 8-2
 - connecting cable, 8-4
 - connectors, 8-4
 - mounting terminal block and connecting cable, 8-10
 - screw-type terminals, 8-10
 - spring-loaded terminals, 8-10
 - wiring, 8-4
 - wiring actuators/sensors to terminal block, 8-10
 - wiring rules, 8-7
 - wiring the front connector module, 8-6
 - wiring with modules..., 8-3
- Simulator module, SM 374; IN/OUT 16, 5-3
- Sinusoidal interference, 1-7
- SM 321; DI 16 x 24 VDC
 - channel-specific diagnostic data, B-5
 - diagnostic interrupt, 3-31
 - diagnostics, 3-26
 - EPROM error, 3-30
 - external auxiliary voltage missing, 3-30
 - fuse blown, 3-30
 - input delay, 3-26
 - internal auxiliary voltage missing, 3-30
 - interrupts, 3-31
 - lack of encoder supply, 3-30
 - redundant encoder supply, 3-24
 - voltage type, 3-26
 - watchdog, 3-30

- SM 321; DI 16 x 24 VDC
 - causes of error and remedial measures, 3-30
 - diagnostic interrupt, 3-26
 - hardware interrupt, 3-26, 3-32
 - hardware interrupt lost, 3-30, 3-32
 - interrupt-triggering channels, 3-32
 - parameters, wrong, 3-30
 - RAM error, 3-30
- SM 322; DO 8 x 24 VDC/0.5 A
 - apply substitute value "1", 3-75
 - causes of error and remedial action, 3-78
 - channel-specific diagnostic data, B-5
 - diagnostic interrupt, 3-75, 3-79
 - diagnostic messages, 3-77
 - EPROM error, 3-78
 - fuse blown, 3-78
 - hold last value, 3-75
 - interrupts, 3-79
 - no external auxiliary voltage, 3-78
 - no internal auxiliary voltage, 3-78
 - no load voltage L+, 3-75, 3-78
 - parameters, 3-75
 - RAM error, 3-78
 - short-circuit to L+, 3-75, 3-78
 - short-circuit to M, 3-75, 3-78
 - substitute value application, 3-75
 - watchdog, 3-78
 - wire-break, 3-75, 3-78
- SM 331; AI 8 x 13 bits
 - Interference frequency suppression, A-28
 - Measuring methods and measuring ranges, A-28
 - structure of data record 1, A-27
- SM 331; AI 8 x RTD
 - interference frequency suppression, A-16
 - operating modes, A-16
 - parameters, A-11
 - smoothing, A-18
 - structure of data record 1, A-12
 - structure of data record 128, A-13
 - Temperature coefficient, A-18
- SM 331; AI 8 x RTD x 24 bits, measuring methods and measuring ranges, A-16
- SM 331; AI 8 x TC
 - interference frequency suppression, A-24
 - measuring methods and measuring ranges, A-25
 - operating modes, A-24
 - parameters, A-19
 - reaction to open thermocouple, A-26
 - smoothing, A-26
 - structure of data record 1, A-20
 - structure of data record 128, A-21
- SM 332; AO 8 x 12 bits
 - Parameters, A-38
 - Structure of data record 1, A-39
- SM 338
 - detection of encoder value, 5-11
 - Encoder value detection, 5-11
 - Functions, 5-11
 - isochrone mode, 5-9
 - POS input module, 5-8

- SM 338; POS-INPUT
 - addressing, 5-16
 - auxiliary voltage missing, 5-20
 - causes of errors and troubleshooting, 5-20
 - channel error, 5-20
 - channel information present, 5-20
 - channel-specific diagnostic data, B-8
 - code type, 5-15
 - configuration error, 5-20
 - diagnostic data, B-7
 - diagnostic interrupt, 5-21
 - diagnostic interrupt enable, 5-14
 - diagnostics, 5-18
 - encoder absolute (SSI), 5-14
 - encoder error, 5-20
 - external error, 5-20
 - Freeze function, 5-13, 5-15
 - group error LED, 5-18
 - internal error, 5-20
 - interrupts, 5-21
 - module malfunction, 5-20
 - monoflop time, 5-15
 - Normalizing, 5-12
 - normalizing, 5-15
 - parameterization error, 5-20
 - parameterization missing, 5-20
 - parameters, wrong, 5-20
 - SF LED, 5-18
 - transmission rate, 5-15
 - watchdog tripped, 5-20
 - Smoothing, Glossary-9
 - SM 331; AI 8 x RTD, A-18
 - SM 331; AI 8 x TC, A-26
 - Smoothing analog input values, 4-40
 - analog input module, 4-46
 - Spare parts, D-1
 - Spring-loaded terminals, SIMATIC TOP
 - connect/...TPA, 8-10
 - Standards and approvals, 1-2
 - Startup, Glossary-9
 - Status mode, Glossary-9
 - STEP 7 blocks, for analog functions, 4-1
 - Substitute value, Glossary-9
 - analog output module, A-37
 - Substitute value "1" application, SM 322; DO 8 x 24 VDC/0.5 A, 3-75
 - Substitute value application, SM 322; DO 8 x 24 VDC/0.5 A, 3-75
 - Supply voltage failure, of the analog module, 4-35
 - System diagnostics, Glossary-9
 - System function (SFC), Glossary-9
-
- T**
 - Technical specifications, RS 485 repeater, 7-7
 - Temperature coefficient, Glossary-9
 - analog input module, 4-46
 - SM 331; AI 8 x RTD, A-18
 - Temperature error, Glossary-10
 - Temperature errors of internal compensation, Glossary-10
 - Temperature measurement, SM 331; AI 8 x 13 bit, A-27
 - Temperature unit, Analog input module, 4-45
 - Test voltages, 1-12
 - Thermo emf, 4-63
 - Thermocouple
 - design, 4-63
 - open, reaction to, Glossary-7
 - principle of operation, 4-63
 - Thermocouple connection, to analog input module, 4-63
 - Three-conductor connection, 4-59, Glossary-10
 - Transmission rate, SM 338; POS-INPUT, 5-15
 - Two-conductor connection, 4-59, Glossary-10
 - Two-wire transmitter, Glossary-10
 - Two-wire transmitters, 4-56

U

- UL, Approval, 1-3
- Underflow, analog input module, 4-80
- Ungrounded operation, RS 485 repeater, 7-4
- Use in an industrial environment, 1-5
- Use in residential environments, 1-5
- Use of the ET 200 / S7-300 in Zone 2, 1-17
- User program, Glossary-10
 - parameter assignment in, A-1

V

- Vibrations, 1-10
- Voltage sensors, connecting, 4-54
- Voltage type, SM 321; DI 16 x 24 VDC, 3-26

W

- Watchdog
 - SM 321; DI 16 x 24 VDC, 3-30
 - SM 322; DO 8 x 24 VDC/0.5 A, 3-78
- Watchdog tripped, SM 338; POS-INPUT, 5-20
- Wire-break, Glossary-10
 - Analog input module, 4-79
 - analog input module, 4-80
 - SM 322; DO 8 x 24 VDC/0.5 A, 3-75, 3-78
- Wire-break check, analog input module, 4-44
- WR_DPARM, SFC 56, A-2
- WR_PARM, SFC 55, A-2