

# SIEMENS

## SIMOREG K 6RA24

Instruction Manual

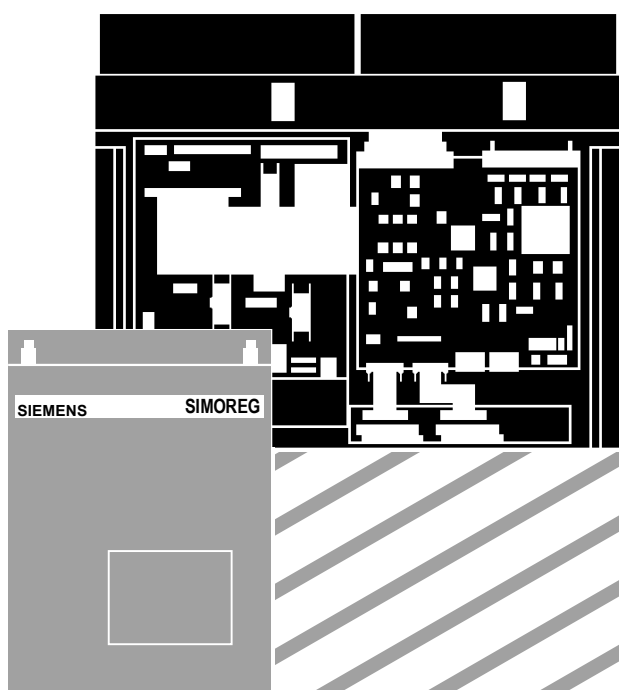





## Supplement to Operating Instructions 6RA24 (Equipment Software Version 2.00, 2.10, 2.20)

### New Software Version 2.30

#### Section 8. Operation

o3.2 Wait until a contactor in the DC circuit has picked up (Waiting Time P095). **from SW2.30**

#### Section 9. Parameter List:

##### **P095 Pickup time of a contactor in the DC circuit **from SW2.30****

If the DC output (Terminals 1C1 and 1D1) is switched to the motor via a contactor and if this contactor is triggered by the "Relay for the mains contactor" (Terminals 109 and 110), the firing pulses may only be enabled when the contactor has positively picked up. For this purpose, an additional waiting time may be necessary during the starting operation. The time set in P095 starts to run during the course of a starting operation on reaching Operating State o5. If this time has not elapsed on quitting Operating State o4, State o3.2 will be maintained until elapse of this time.

Works setting: 0.00 s                      Range of values (increments): 0.00 to 1.00s (0.01s)

Access: 20                                      Change: on-line

##### **P152 Filtering of system frequency correction (armature)**

(see Section 10.1 Sheet 18)

The internal system synchronization for the armature firing pulses derived from the power terminals (armature system supply) is filtered with this time constant. In the case of operation on "weak", frequency unsynchronized systems, for example in the case of supply by means of diesel generator (isolated operation), the filter time constant to achieve higher frequency correction rate must be parameterized lower than is the case with operation on "rigid" systems.

Value 0:        No filtering or averaging of the system detected zero crossing

Values 1 to 9: Use averaging method for detection of the system zero crossings

Value 1:        Averaging over the detected system zero crossings of the last system period

Value 2:        Averaging over the detected system zero crossings of the last 2 system periods

....

Value 9:        Averaging over the detected system zero crossings of the last 9 system periods

Values 10 to 200 ms (even number): use filtering method for detection of the system zero crossings

Values 11 to 199 ms (odd number): Use filtering method for detection of the system zero crossings (additional "filtering" of the detected system zero crossings takes place for system synchronization. This can provide improvement in problem cases with brief system interruptions (e.g. in the case of current supply via sliding-action current collector), may only be set with fixed-frequency systems, but not however with "flexible" separate networks).

Note:        Changing the P152 from values > 9 to values ≤ 9 and vice versa (that is to say changing the method of detecting system zero crossings) will only become effective when the voltage is removed at the power circuit. The same also applies to all value changes within the range of 1 to 9.

Remark: Additional filtering (values 11 to 199 ms, odd) implemented from SW2.20. Averaging method (values 1 to 9) implemented from SW2.30

Works setting: 200ms                      Range of values (increment): 0 to 200ms (1ms)

Access: 40                                      Change: on-line

## P153 Control word: armature pilot control

(see Section 10.1 Sheet 18)

### Use of pilot control:

- xx0 Armature pilot control disabled, output of pilot control =165°
- xx1 Armature pilot control active
- xx2 Armature pilot control computed for EMF=0; in the event of change of torque direction, current controller integrator set to difference of pilot control (EMF) – pilot control (EMF=0) (to be set when supplying high inductances from the armature terminals, e.g. solenoids, field supply) from SW2.00

### Method of EMF calculation for pilot control:

from SW2.30

- x0x Use of the EMF determined from the measured armature voltage
- x1x Use of the EMF determined from the calculated armature voltage  
(This setting is used to reduce any low-frequency (< 15 Hz) armature current fluctuations. For this purpose, P152 should be set to values 7 to 9).

### Method of EMF filtering:

from SW2.30

(K122 is obtained by filtering (according to the hundreds digit of P153) of the EMF values selected according to the tens digit of P153)

- 0xx 1st order filter (PT1 element), filter time constant approximately 10 ms
- 1xx No filtering
- 2xx Averaging over the last 2 EMF values
- 3xx Averaging over the last 3 EMF values

### Remark:

Any low-frequency armature current fluctuations occurring (< 15Hz) are (with armature pilot control active) best compensated when P153=111; this setting will however cause increased "short-time current irregularity" (differing heights of consecutive armature current crests). With more rigorous EMF averaging (P153= 211, 311), the vibration-compensating action of K124 is reduced, but the "short-time current irregularity" is less. A recommended setting is P153=211 together with P152=9.

Works setting: 001

Range of values: 000 to 312

Access: 20

Change: off-line

## **P224 Control word: Speed controller**

(see Section 10.1 Sheet 15)

- xxx0 Set controller integral-action component to Zero (i.e. pure proportional-action controller)
- xxx1 Controller integral-action component active  
on reaching a torque or current limit, the integral-action component will be halted
- xxx2 Controller integral-action component active from SW 2.30  
On reaching a torque limit, the integral-action component will be halted
- xxx3 Controller integral-action component active from SW 2.30

The integral-action component is only halted on reaching +-199.99%

- xx0x Set controller proportional-action component to Zero (i.e. pure integral-action controller)
- xx1x Controller proportional-action component active

x0xx The setpoint is applied correctly signed

x1xx The setpoint is applied in negated form

0xxx The actual value is applied correctly signed

1xxx The actual value is applied in negated form

Works setting: 0011

Range of values (increment): 0000 to 1113 (1Hex)

Access: 20

Change: off-line

## **P305, P306, P309, P310, P313, P314 (Ramp-function generator initial and final rounding)**

Range of values: 0.00 to 100.00 s (instead of previously 0.00 to 10.00 s)

## Section 10. Function:

### New connectors:

**K109** Armature current actual value (average over the last 6 current crests in each case), signed

**K122** EMF which is used as input value for the armature pilot control  
Scaling: as K287

**K123**  $EMF = U_a - I_a \cdot R_a - L_a \cdot di_a/dt$ , where the measured armature voltage is used for  $U_a$ .  
(Remark: PT1 filtering produces K287)  
Scaling: as K287

**K124**  $EMF = U_a - I_a \cdot R_a - L_a \cdot di_a/dt$ , where a calculated armature voltage is used for  $U_a$ .  
Scaling: as K287

**K355**  $I_a \cdot R_a + L_a \cdot di_a/dt$  ... sum of resistive and inductive armature voltage drop  
the sign is correct in torque direction MI  
Scaling: as K287

**K356** Armature current instantaneous value at ignition point, calculated from the last 2 armature current sampled values before ignition point  
Scaling: 818 ... unit rated DC current (armature) per P072

**K359** T1 value of last-occurred I=0 signal or ignition point of the previous ignition cycle if, on account of I=0 or continuous armature current, no I=0 signal occurred

**K360** Interval of the averaged system synchronization time-reference point (per K362, K363) from the "unfiltered" zero crossing of the sampled and software-filtered system voltage (of phase per K361) in 1.778  $\mu s$  (where P152= 1 to 9)

**K361** Code, to which system phase the averaged system synchronization time-reference point (per K362, K363) is assigned (where P152= 1 to 9)

|   |    |   |    |    |    |
|---|----|---|----|----|----|
| 0 | UV | 2 | UW | 4  | VW |
| 6 | VU | 8 | WU | 10 | WV |

**K362** T1 value (Low word) of the averaged system synchronization time-reference point (where P152= 1 to 9)

**K363** T1 value (High word) of the averaged system synchronization time-reference point (where P152= 1 to 9)

**K364** Mean interval of two (60° separated) zero crossings (where P152= 1 to 9) in 1.778  $\mu s$

**K389** Current flow duration of armature current crest of previous ignition cycle measured by means of I=0 signal in 1.778  $\mu s$

**New "binary output functions":** (adjustable at P771 to P774)

**36** Voltage isolation (OUT2) present (Low active)

**37** Quick Stop (OUT3) present (Low active)

## Supplement to the 6RA24 Instruction Manual (drive converter software release, 2.00, 2.10)

### New drive converter software release 2.20

#### to Section 9. Parameter list:

Modified setting ranges or expanded functionality for the following parameters:

**P053:** Value range: 00 to 21 (instead of 00 to 11 as before)

2x Only the contents of the fault memory (numbers of the last 4 faults/errors which occurred) are stored in the permanent memory, as otherwise no process data which is immune to voltage failure (non-volatile process data).

**P142:** Value range: 0000 to 2112 (instead of 000 to 112 as before)

The measuring time for the speed actual value sensing using pulse encoder can be changed as follows using the thousands position:

0xxx nominal measuring time 1 ms (factory setting)

1xxx nominal measuring time 2 ms (results in a „steadier“ speed actual value than for 0xxx)

2xxx nominal measuring time 4 ms (for drives with a high moment of inertia, results in a „steadier“ speed actual value than for 0xxx, P200 should be parameterized to min. 5 ms)

#### **P152, P252:**

The line supply synchronizing function can be additionally changed as follows using the ones location:

Uneven number ... additional „filtering“ of the sensed line supply zero crossovers for line supply synchronization, can improve the situation for problem situations with short line supply interruptions (e.g. for current feed via slip rings); this can only be used for supply networks with a stiff frequency (however, not for island networks)

**P253:** Value range: 00 to 21 (instead of 0 to 1 as before)

The tens locations defines the input quantity to determine the motor flux:

0x Input quantity to determine the machine flux is the field current controller actual value according to P612 (K265), when a fully-compensated DC motor is used (factory setting).

1x The feed-forward output for the EMF controller (K293) is the input quantity to determine the machine flux  
(Exception: Field current controller setpoint (K268) when the standstill field is active or for field pulse inhibit) is used when an uncompensated DC motor is used. For this setting, the EMF controller must be active (EMF controller compensates the armature reaction).

2x The field current controller setpoint (K268) is the input quantity to determine the machine flux  
Advantage: Quantities derived from the setpoint are generally steadier (smoother) than quantities derived from the actual value.

**P302:** Value range: 000 to 231 (instead of 00 to 31 as before)

The hundreds location controls the ramp-function generator output setting at the start of a „shutdown“ command:

0xx The ramp-function generator output is not set at the start of „shutdown“  
(setting corresponds to software version ≤ 2.00) (factory setting)

1xx At the start of „shutdown“, the ramp-function generator output is set to the speed actual value K167 (speed actual value K167 is „unfiltered“) (setting corresponds to software release 2.10 for P629 = 2)

2xx At the start of „shutdown“, the ramp-function generator output is set to the speed controller actual value K165 (filtering using P200 and filter are effective)  
This setting cannot be used for P205 > 0

During „shutdown“ the ramp-function generator output limiting is not effective. P302 should be set to 1xx or 2xx, so that a (temporary) speed increase does not occur when the ramp-function generator output is limited at shutdown.

**P355:** Value range: 0.0 to 600.0 s (instead of 0.0 to 60.0 s as before)

From software release 2.20, for P355= 0.0, the „drive stalled“ monitoring (F035) is disabled; thus alarm W08 cannot occur.

**P642, P761, P762, P763, P764, P765, P766:** value range: 0 to 69 (instead of 0 to 68 as before)

## to Section 10. Functions:

**Binary input function, BEF69:** Enabling the ramp-up integrator changeover

This binary input function (BEF69) is selected with setting 69 of the particular select parameter.

|        |              |   |
|--------|--------------|---|
| Level: | 0            | When the <u>ramp-up integrator function</u> is selected (P302= 1x, 2x or 3x, refer to the Section 9.2), it is not possible to changeover from ramp-function generator setting 1 to the setting according to the tens location of P302. <u>Ramp-function generator setting 1 is used</u> (if ramp-function generator setting 2 or 3 is not selected using BEF31 or BEF32).   |
|        | 1 (not used) | When the <u>ramp-function integrator</u> function is selected (P302= 1x, 2x or 3x, refer to Section 9.2), there is an <u>automatic changeover</u> from ramp-up function generator setting 1 to the setting according to the tens location of P302 as soon as the ramp-function generator output reaches the required setpoint for the first time after an „ON“ command (and for the first time after BEF 69 = 1). |

If the logical signal level of BEF69 changes from 1 to 0 after an automatic ramp-function generator setting changeover, ramp-function generator setting 1 is again re-used. The changeover enable is re-activated when the signal level of BEF69 changes from 0 to 1, i.e., when the required setpoint is reached the next time, then the ramp-function generator setting, corresponding to P302, is again selected.

## to Section 15. SIMOVIS

SIMOVIS for 6RA24 Version 2.20 is supplied together with the basic drive converter software 2.20.

### New functions in the SIMOVIS-V2.20 version

#### a) Starting SIMOVIS

START1 and START2 are eliminated (COM1 or COM2 are selected in the bus configuration).

#### **Start with bus configuration: START**

You thus enter a table, in which the slave number, the drive converter type, and if required the technology software and user names are visible for every unit connected to the USS bus.

By clicking twice with the lefthand mouse key (or with the cursor keys UP or DOWN and the RETURN-key) on any number on the lefthand edge, the appropriate line can be edited. A slave type (6RA24, 6RA23, 6SE70 RRU, FC, VC, SC) and if required, a technology software, can be selected one after another in the window which opens, and any user name can be assigned to the slave.

A slave can again be deleted by entering type " 0 --- ".

#### **Starting without bus configuration: RUN**

## b) Bus configuration (changes over SIMOVIS version 2.1)

- new function key F10 DOS (return to DOS).
- An individual number of process data words can be selected for each bus node (0 to 16, pre-setting=3).
- Improved handling of the baud rate selection field (click somewhere in the field, and enter a new value).
- New selection field to select COM1 or COM2.
- F10 Save is eliminated; F8 Continue includes a check as to whether the bus configuration was changed: If yes, a save prompt is output.

## c) Upreading / Downloading

- Only the file names of upread- or download files, which match the currently selected unit, are listed in the overview windows.
- Nibble-coded parameters now appear for upread and download in the usual hexadecimal notation.
- The files can be read and printed, also under DOS.
- There are now more ways to manipulate files: e.g. if two download files are compared, this results in an additional download file which only includes the differences between the files which were compared.
- Faster upreading/downloading if many nodes are connected to the USS bus; the actual unit has higher priority handling (upreading/downloading hardly takes any longer than point-to-point data transfer)
- The file names for the upread files, supplied on the SIMOVIS-floppy disks, no longer start with „INIT ...“. Thus, these files can also be freely edited.
- Upread files are now supplied with units with software releases V1.2 and V1.3. Thus, when replacing software, parameters can also be transferred from such units.  
**Caution:** Parameters P624, P764 and P765 cannot be addressed using the current SIMOVIS. They must be manually read-out, and entered in the \*.R4D file.  
(provide a retainer at the start of ALL2413.R4U)

## d) Functions

- User-friendly evaluation of the trace memory with curve graphics (zooming is now supported)

## e) Operator control interface

- New graphic layout of the function keys.
- Faults and alarms can be directly called-up from the main menu.
- The column for the „nibble index“ for L2 parameters is no longer provided in the display for free parameter input (UV2198). L2 parameters are only displayed here completely with all four nibbles, and entered.
- Labeling of the group messages in the display header at the right: Communications (C), Error (E), Warning (W).

# SIEMENS

Supplement to the 6RA24 Instruction Manual (converter software release 2.00)

## New converter software release 2.10

### Regarding Section 9. Parameter list:

The setting ranges have been changed for the following parameters:

- |             |   |
|-------------|---|
| <b>P158</b> | Ramp-up time for the current setpoint integrator (reduced gearbox stressing)<br>Value range: 0.000 to 1.000s (instead of previously, 0.000 to 0.100s) |
| <b>P351</b> | Threshold for the undervoltage trip<br>Value range: 0 to -90% (instead of previously, 0 to -20%)  |
| <b>P352</b> | Threshold for the overvoltage trip<br>Value range: 0 to 99% (instead of previously, 0 to 20%)   |
| <b>P640</b> | Selecting the data source for control word STW<br>Value range: 0 to 399 (instead of previously, 19 to 83)   |
| <b>P641</b> | Selecting the data source for the freely-definable control word STWF<br>Value range: 0 to 399 (instead of previously, 19 to 83)                       |

### Regarding Section 10. Functions:

New connectors:

- |             |   |           |
|-------------|---|-----------|
| <b>K337</b> | Number of the most current fault signal     | (P880.00) |
| <b>K338</b> | Number of the next to last fault signal     | (P880.01) |
| <b>K339</b> | Number of the third from last fault signal  | (P880.02) |
| <b>K340</b> | Number of the fourth from last fault signal | (P880.03) |

### Regarding Section 15. SIMOVIS

SIMOVIS for 6RA24, release  $\geq 2.00$ , is supplied together with the basic drive converter software 2.10. The most important new feature is that this version is „bus capable“ i.e. it can be operated in a common installation with SIMOVIS of the 6SE70 MASTER DRIVES converter system.

Now, each has its own start procedure, START 1 for the COM 1 interface and START2 for the COM 2 interface.

After starting SIMOVIS with either START1 or START2, you enter a table where every drive converter connected to the USS bus, the slave number, the drive converter type and if applicable, technological software and user names are visible.

The appropriate line can be edited by clicking twice with the lefthand mouse key on any number in the lefthand border (or using the RAISE or LOWER cursor keys and RETURN): The following can then be consecutively selected in the opening windows: A slave type (6RA24, 6RA23, 6SE70 RRU, FC, VC, SC) and if required technological software and any name can be assigned to the slave.

A slave can be deleted again by entering type " 0 --- ".

A modified slave configuration is saved with F10 SAVE. Changes are rejected with F8 CONTINUE and SIMOVIS is started with the old setting.

The following display with alarm information is acknowledged with F1 START. You can then see a display in which the first defined slave is signaled back with user names. You can call-up the first SIMOVIS display for the current drive converter using F1 BASIC CONVERTER. (a technological SIMOVIS is not available for the technology boards which can be operated in the 6RA24).

To select another slave, click in the display header in the numerical field next to the text CONV.ADR (drive converter address). A selection menu, with the defined slaves and their user names, opens, from which a drive converter can be selected. After selection, you can enter the basic display of the appropriate drive converter (selection basic drive converter- technological SW).



# **SIEMENS**

## **SIMOREG K**

**850A Modular Converters with a Fully-Controlled Three-Phase  
Bridge Circuit B6C as well as a Circulating-Current-Free Anti-  
Parallel Circuit (B6)A(B6)C for Variable-Speed DC Drives  
6RA24 Series**

**Supplement to Instruction Manual 6RX1240-0AD76**

## 2 Type spectrum

### Master drive converters

| Converter Order No. | Type designation           |
|---------------------|----------------------------|
| 6RA2487-6DS22-0     | D485 / 850 Mre - GeEF6S22  |
| 6RA2487-6GS22-0     | D600 / 850 Mre - GeEF6S22  |
| 6RA2487-6DV62-0     | D420 / 850 Mreq - GeGF6V62 |
| 6RA2487-6GV62-0     | D520 / 850 Mreq - GeGF6V62 |

### Slave drive converters for a parallel circuit configuration

| Converter Order No. | Type designation           |
|---------------------|----------------------------|
| 6RA2487-6DS00-0     | B6C 400/540-850G001        |
| 6RA2487-6GS00-0     | B6C 500/675-850G001        |
| 6RA2487-6DV00-0     | (B6)A(B6)C 500/675-850G001 |
| 6RA2487-6GV00-0     | (B6)A(B6)C 500/675-850G001 |

## 3 Description

### 3.2 Design

The 6RA24.. converter series with electrically insulated thyristor modules has been expanded by a type with a rated current up to 850 A. The rated supply voltages are 400 V and 500 V.

In addition to the single- and four-quadrant versions (master), the same power sections (slave) have been developed for a parallel circuit configuration. Currents up to 1700 A or 2500 A are possible by connecting two or three drive converters in series. The slave units have neither closed-loop electronics nor a field supply.

The slave units are controlled from the master drive converter. A signal cable is used for signal transfer between the master and slave. The standard version of the ribbon cable is included with the slave converter.

The power section cooling is monitored by sensing the fan speed.

### 3.4 Technical data

#### 850A drive converters, 3AC ("Master" in a parallel circuit configuration)

| Order No.  | 6RA2487-6DS22  | 6RA2487-6DV62 | 6RA2487-6GS22                         | 6RA2487-6GV62 |
|--|--|---------------|---------------------------------------|---------------|
| Rated supply voltage armature<br>V                 | 3-ph.AC400 (+15% /-20%) <sup>1)</sup>  |               | 3-ph.AC500 (+15% /-20%) <sup>1)</sup> |               |
| Rated supply voltage electronics power supply<br>V | 2-ph.AC 400 (+15% / -25%); I <sub>n</sub> =0,5A<br>(-35% for 1min)   |               |                                       |               |
| Rated supply voltage fan<br>V                      | 3-ph.AC 400 (±15%) 0,24A, 95 Watt<br>Air flow: 570 m <sup>3</sup> /h , Fan noise: 63 dBA   |               |                                       |               |
| Rated supply voltage field<br>V                    | 2-ph.AC400 (+15% /-20%)  |               |                                       |               |
| Rated frequency<br>Hz                              | Im Bereich 45 bis 65 Hz passen sich Anker und Feld unabhängig voneinander automatisch an die Netzfrequenz an.  |               |                                       |               |
| Rated DC voltage<br>V                              | 485  | 420           | 600                                   | 520           |
| Rated DC current<br>A                              | 850  |               |                                       |               |
| Overload capability                                | max. 150% rated DC current <sup>3)</sup>   |               |                                       |               |
| Rated output<br>kW                                 | 412  | 357           | 510                                   | 442           |
| Power loss at rated DC current (approx.)<br>W      | 2600   |               | 2800                                  |               |
| Rated DC voltage field<br>V                        | max. 325   |               |                                       |               |
| Rated DC current field<br>A                        | 30   |               |                                       |               |
| Operational ambient temperature<br>°C              | 0 to 35 at I <sub>rated</sub> forced-cooled <sup>3)</sup>  |               |                                       |               |
| Storage and transport temperature<br>°C            | -30 to +85   |               |                                       |               |
| Installation altitude above sea level              | ≤ 1000m at rated DC current <sup>4)</sup>  |               |                                       |               |
| Control stability                                  | Δn = 0,006% of the motor rated speed, is valid for pulse encoder operation and digital setpoint.<br>Δn = 0,1% of the motor rated speed, is valid for analog tachometer or analog setpoint. <sup>2)</sup> |               |                                       |               |
| Humidity classification<br>DIN 40040<br>SN 26556   | F  |               |                                       |               |
| Deg.of prot.<br>DIN 40050<br>IEC 144               | IP00   |               |                                       |               |
| Dimensions   | refer to dimension drawings  |               |                                       |               |
| Weight (approx.)<br>kg                             | 45   | 52            | 45                                    | 52            |

Explanation of the footnotes after the tables of the main Instruction Manual 6RX1240-0AD00

### 850A drive converters 3 AC, connected in parallel (“slave“)

| Order No.  | 6RA2487-6DS00  | 6RA2487-6DV00 | 6RA2487-6GS00                         | 6RA2487-6GV00 |
|--|--|---------------|---------------------------------------|---------------|
| Rated supply voltage armature<br>V               | 3-ph.AC400 (+15% /-20%) <sup>1)</sup>  |               | 3-ph.AC500 (+15% /-20%) <sup>1)</sup> |               |
| Rated supply voltage fan<br>V                    | 3-ph.AC 400 (±15%) 0,24A, 95 Watt<br>Air flow: 570 m <sup>3</sup> /h , Fan noise: 63 dBA |               |                                       |               |
| Rated frequency<br>Hz                            | 45 to 65 Hz  |               |                                       |               |
| Rated DC voltage<br>V                            | 485  | 420           | 600                                   | 520           |
| Rated DC current<br>A                            | 850  |               |                                       |               |
| Overload capability                              | max. 150% rated DC current <sup>3)</sup>   |               |                                       |               |
| Rated output<br>kW                               | 412  | 357           | 510                                   | 442           |
| Power loss at rated DC current (approx.)<br>W    | 2600   |               | 2800                                  |               |
| Operational ambient temperature<br>°C            | 0 to 35 at I <sub>rated</sub> forced-cooled <sup>3)</sup>                                |               |                                       |               |
| Storage and transport temperature<br>°C          | -30 to +85   |               |                                       |               |
| Installation altitude above sea level            | ≤ 1000m at rated DC current <sup>4)</sup>  |               |                                       |               |
| Control stability                                | refer to “Master-converter“  |               |                                       |               |
| Humidity classification<br>DIN 40040<br>SN 26556 | F  |               |                                       |               |
| Deg.of prot.<br>DIN 40050<br>IEC 144             | IP00   |               |                                       |               |
| Dimensions                                       | refer to dimension drawings  |               |                                       |               |
| Weight (approx.) kg                              | 43   | 50            | 43                                    | 50            |

Explanation of the footnotes after the tables of the main Instruction Manual 6RX1240-0AD00

## 5.1 Dimension drawings

### Dimension drawing Master-converter

1) Minimum clearance for air circulation.  
It should be ensured that there is  
sufficient cooling air intake!

2) Hole for crane hook

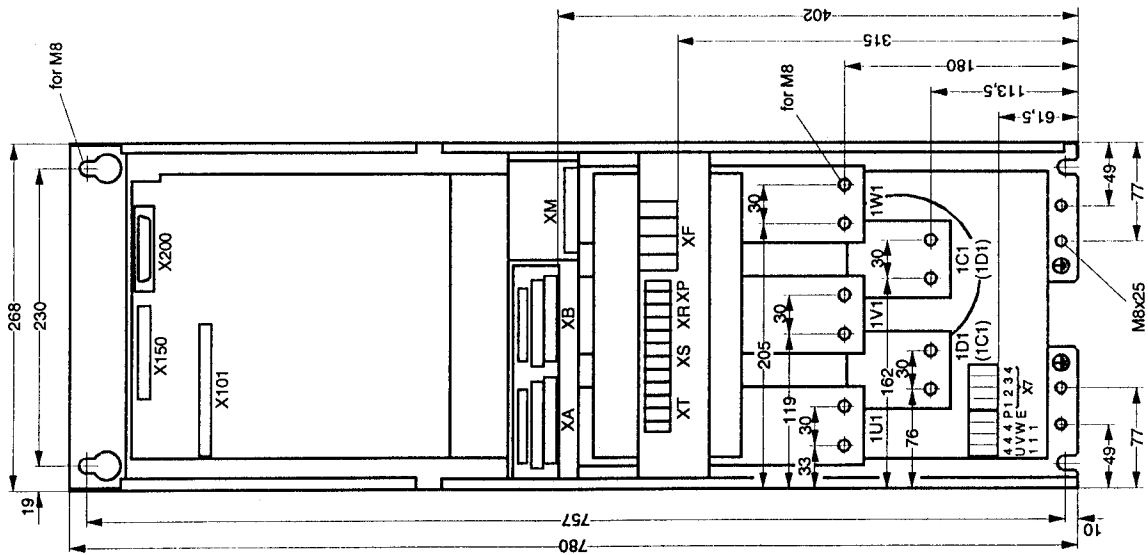
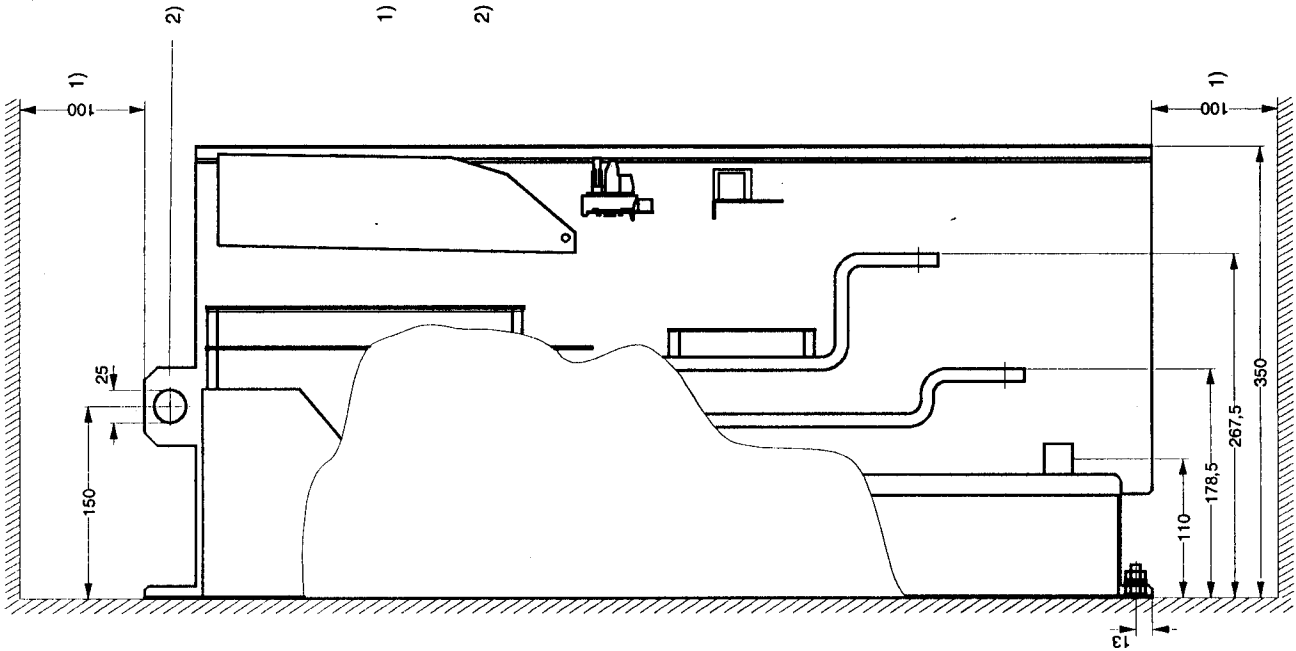

# Dimension drawing Slave-converter

1) Minimum clearance for air circulation.  
it should be ensured that there is  
sufficient cooling air intake!

2) Hole for crane hook

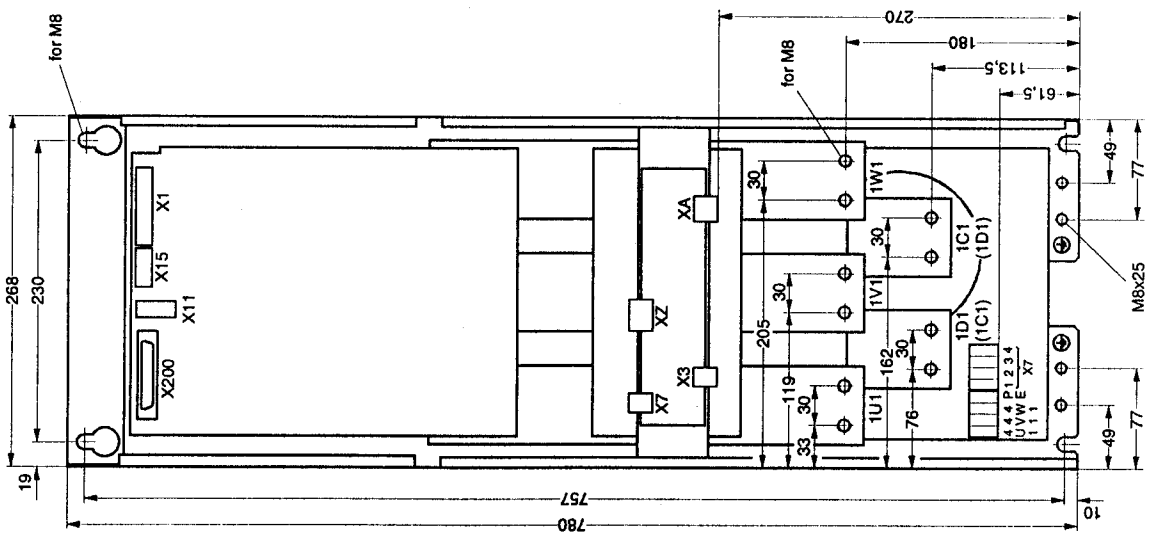
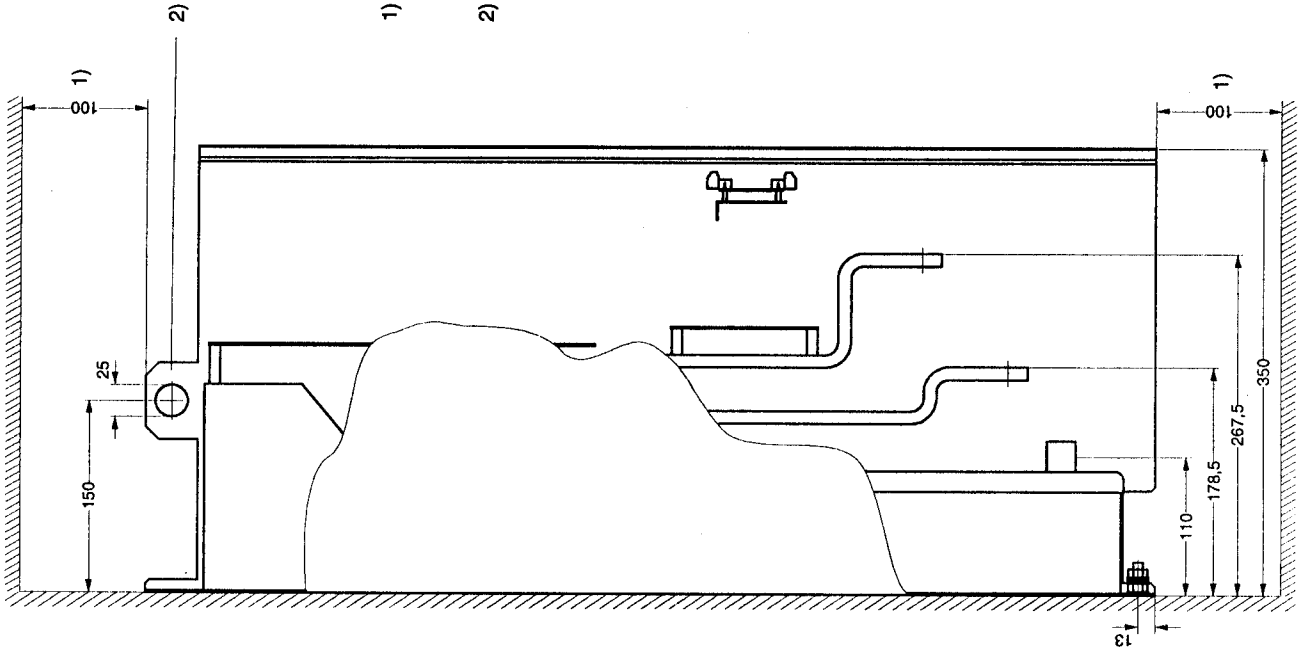

### 6.2 Block diagram with recommended connection

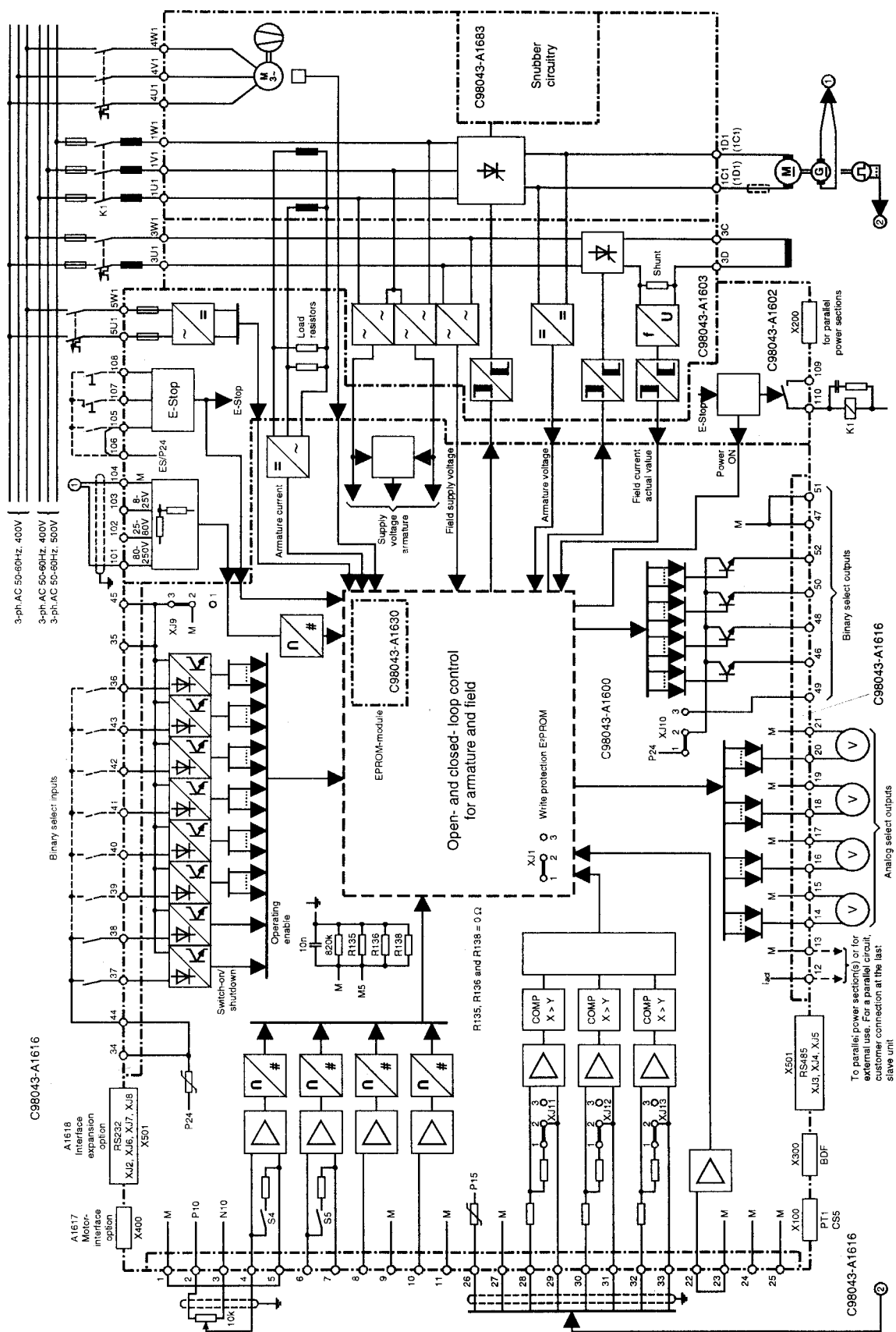



### 6.3 Parallel circuit

- 1) For IQ drive converters, the DC current fusing is not included
- 2) Ribbon cable 6RY1247-0AA14 (1m) component of the slave units or 6DD1684-0BH1 (2m).
- 3) Good potential equalization (bonding) should be ensured.
- 4) The electronics box with adapter board C (6GX5340) and ribbon cable (X3 to X2) is completely available as accessory, Order No. 6CX5346, and is used to connect additional (max. 4) parallel drive converters. The electronics box must be installed in the first parallel drive unit. For more detailed information regarding the adapter board C as well as boards 6CN510-0BA and 6CN5503-0BA, refer to the Instruction Manual "SITOR thyristor set" series 6CG35, Order No.: 6CG3235-0AAD0.
- 5) Ribbon cable 6DD1684-0BH0 (2m) from the adapter board to additional slave units

Separate commutating reactors are required for the SIMOREG drive converter and the slave units for current distribution.

Caution: Only units having the same rated current may be connected in parallel!

Setting parameter P072 (equipment rated DC current):

Sum of the rated DC currents of the SIMOREG- and slave drive converters =  $2 * I_{rated} (SIKPE_{DC}) * (n+1)$  for n slave units in parallel, n = 1 to 5

Setting parameter P074 (control word for the power section):

x1x, if there is 1 parallel slave unit (nxx for n slave units in parallel, n = 1 to 5)

Setting parameters P171 and P172 (current limit):

Maximum value of P171 and P172 =  $\frac{I_{max}}{\text{Rated motor armature current}} * 100\%$

For ambient temperatures above 35°C and installation altitudes above 1000m, the values of  $I_{max}$  must be derated according to the 6RA24 Instruction Manual, Section 3 and P077 in Section 9.2.

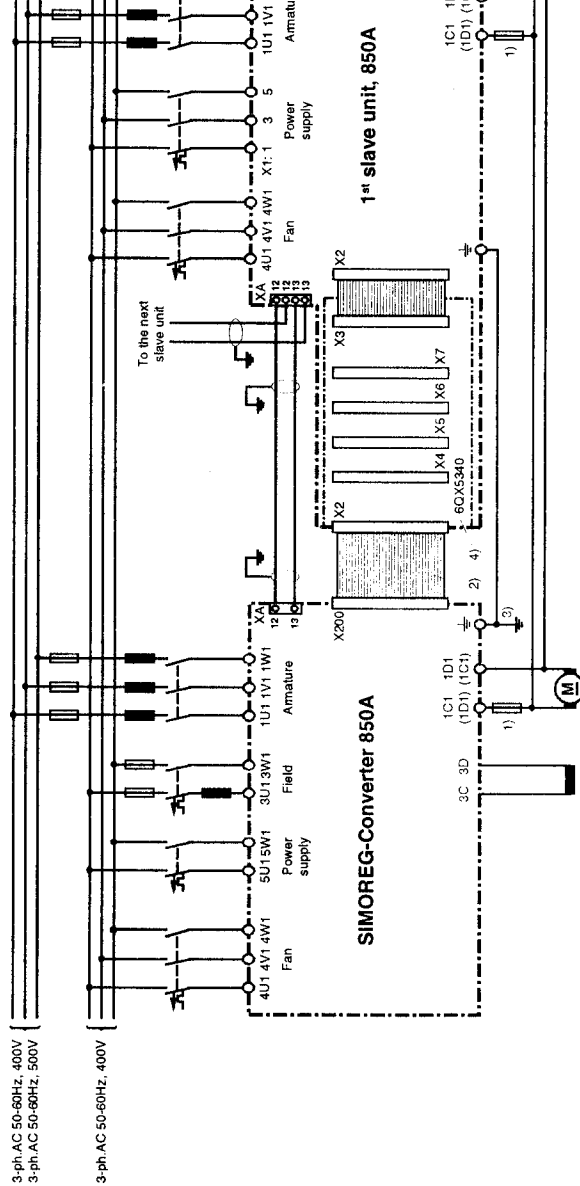
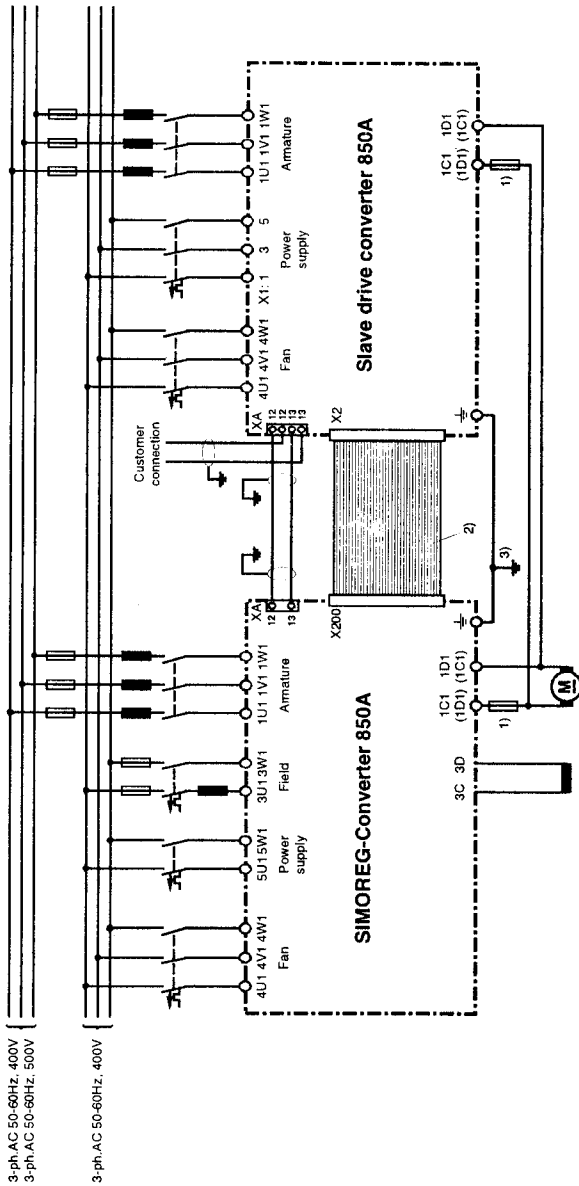

## 6.4 Power connections Converter type D . . . / 850 Mre - GeEF6S22

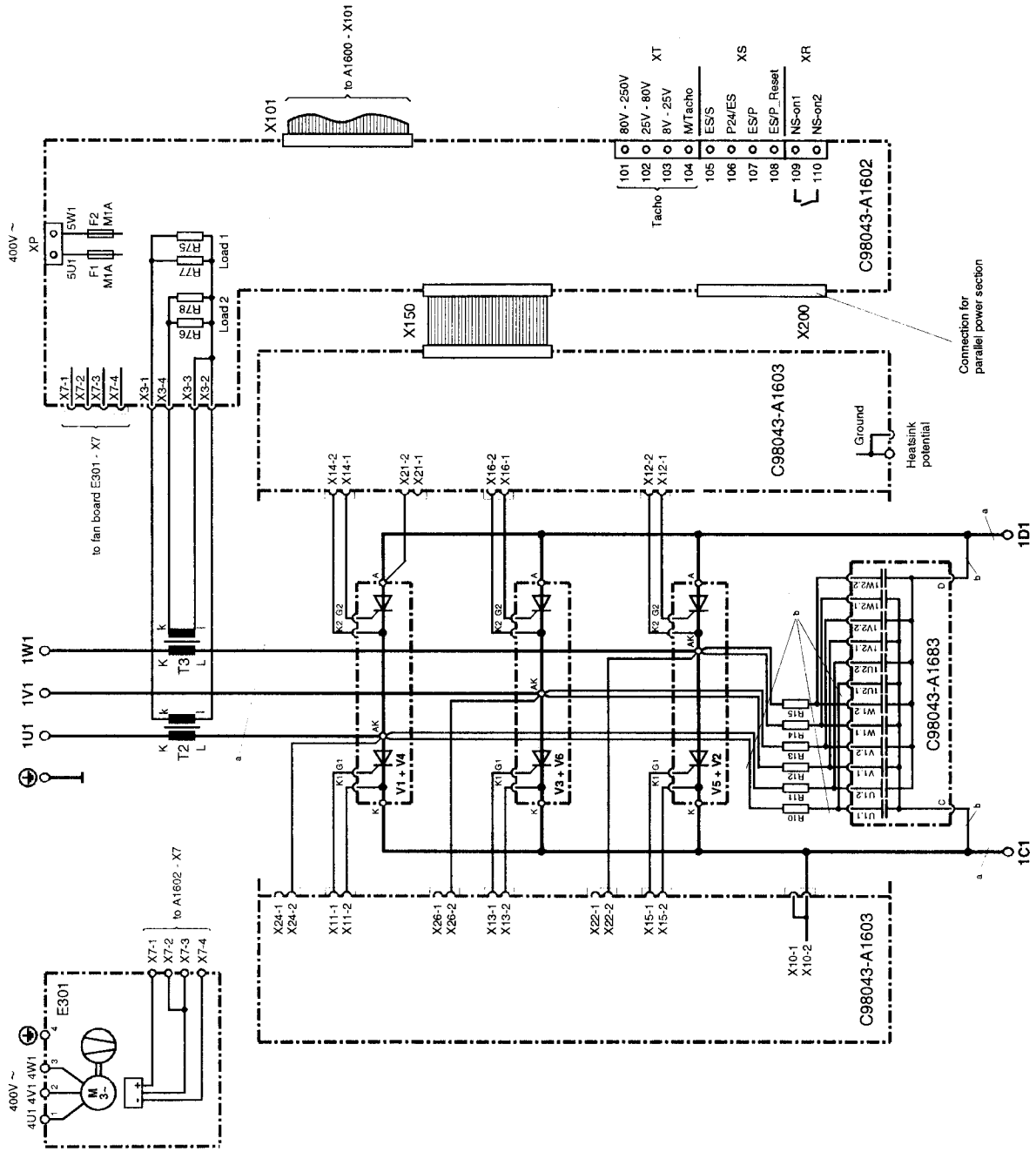

| Load resistor list |                     |
|--------------------|---------------------|
| Resistor           | $I_{A, rated}$ 850A |
| R75                | 3,6 Ω               |
| R76                | 3,6 Ω               |
| R77                | 6,8 Ω               |
| R78                | 6,8 Ω               |

- a: Cubus 60 x 10
  - b: Raychem 440311-14-9
- All cable which are not designated are Soflex TQ 105° 0.5mm<sup>2</sup>  
 G (Gate)-cable ⇒ yellow  
 K (Cathode)-cable ⇒ red

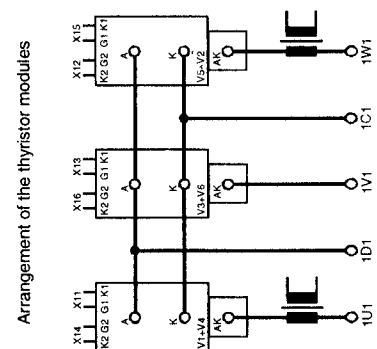

# Converter type D... / 850 Mreq - GeGF6V62

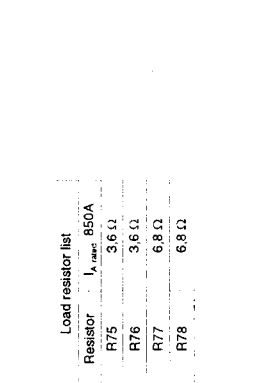
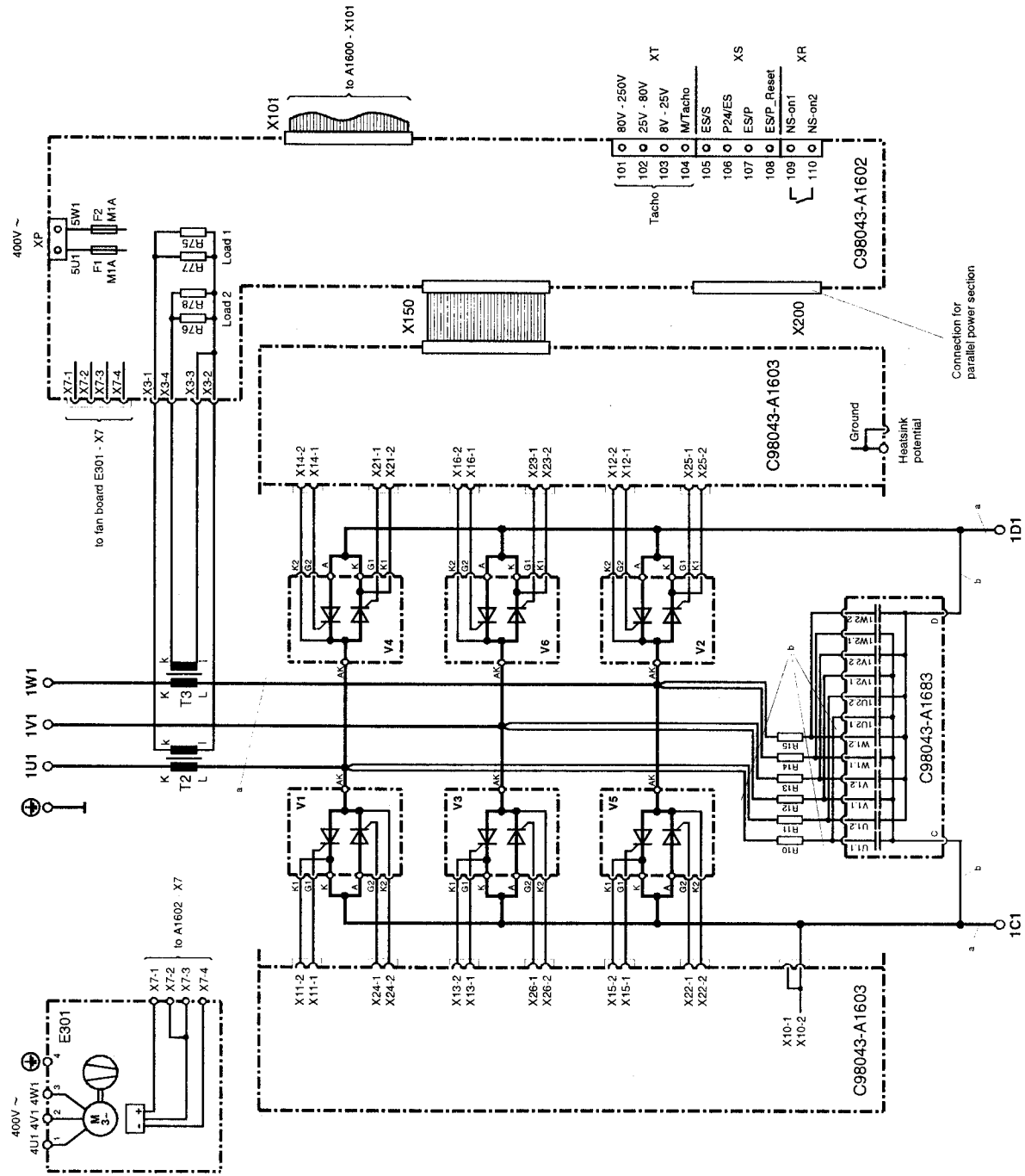

Load resistor list

| Resistor | $I_{A_{max}}$ | 850A |
|----------|---------------|------|
| R75      | 3.6 Ω         |      |
| R76      | 3.6 Ω         |      |
| R77      | 6.8 Ω         |      |
| R78      | 6.8 Ω         |      |

- a: Cubus 60 x 10
  - b: Raychem 440311-14-9
- All cable which are not designated are Soflex TQ 105 0.5mm<sup>2</sup>  
 G (Gate)-cable ⇒ yellow  
 K (Cathode)-cable ⇒ red

Arrangement of the thyristor modules

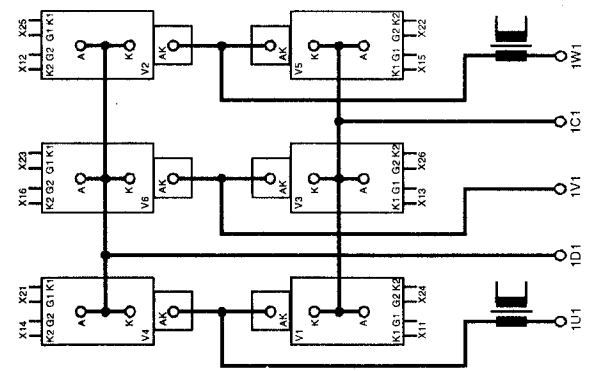

# Converter type B6C ... / ...-850G001

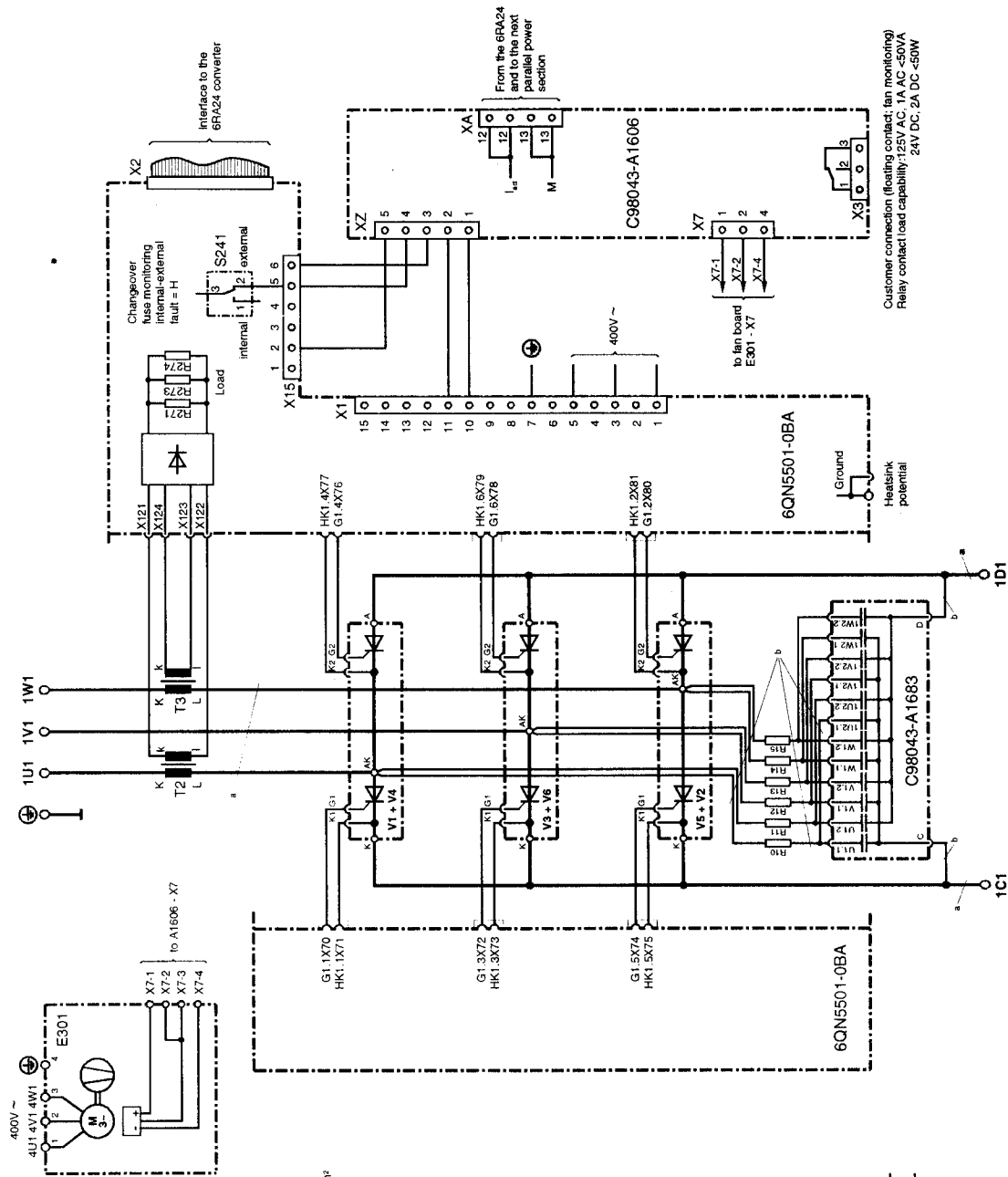

Load resistor list

| Resistor | $I_{max}$   | 850A |
|----------|-------------|------|
| R271     | 3.6 Ω       |      |
| R273     | 6.8 Ω       |      |
| R274     | not mounted |      |

- a: Cubus 60 x 10
  - b: Raychem 440311-14-9
- All cable which are not designated are Solflex TO 105<sup>2</sup> 0.5mm<sup>2</sup>  
 G (Gate)-cable ⇒ yellow  
 K (Cathode)-cable ⇒ red

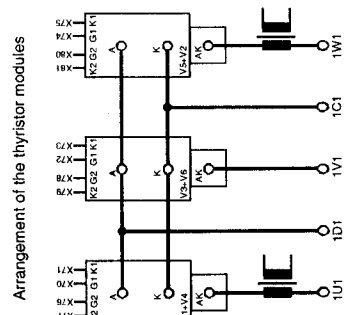

Customer connection (heating contact; fan monitoring)  
 Relay contact load capability: 25V AC - 50VA  
 24V DC - 2A DC - 50W

# Converter type (B6)A(B6)C... / ...-850G001

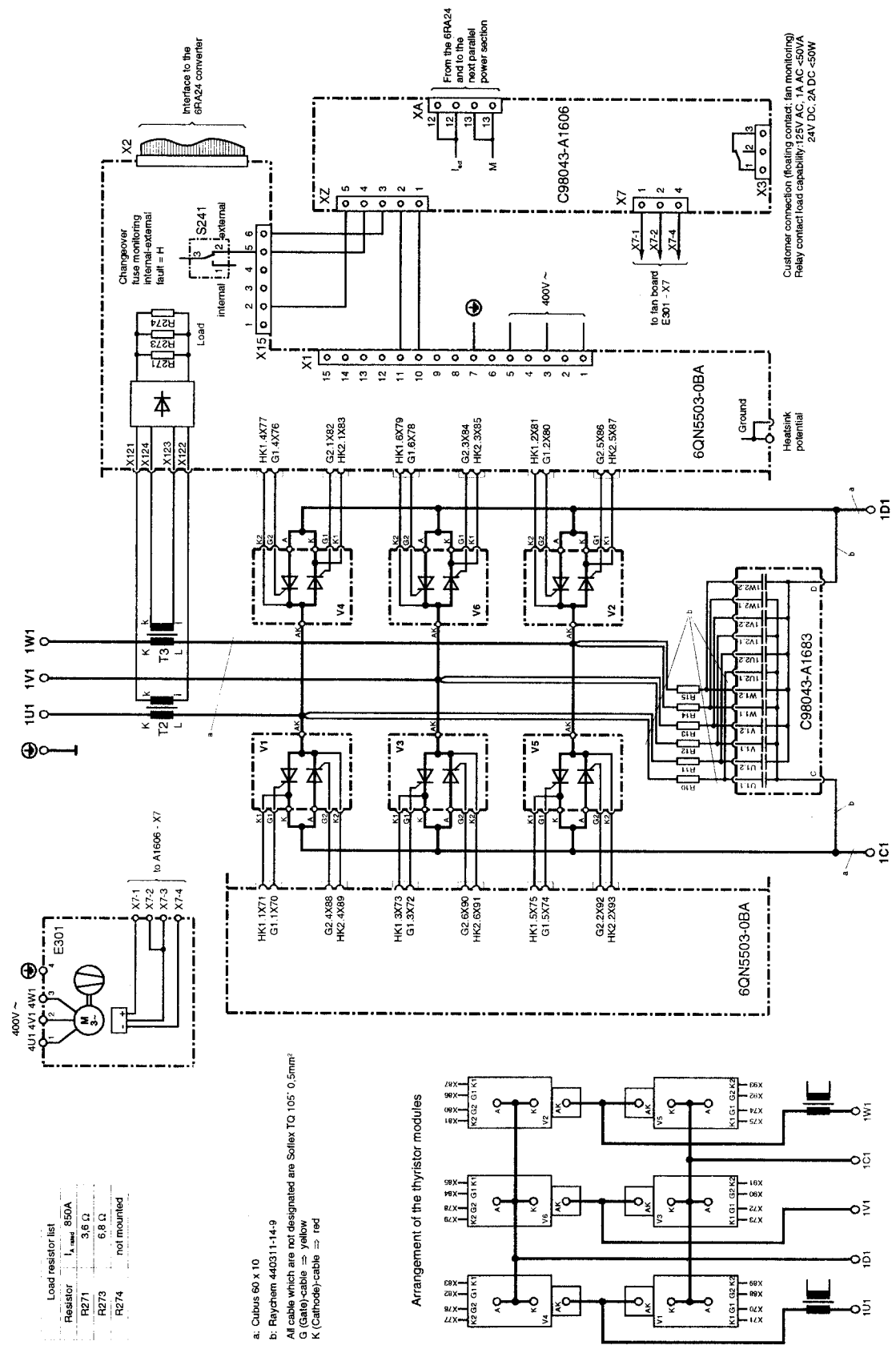

## 6.7 Fuses and commutating reactors

### 6.7.1 Commutating reactors

Commutating reactors should be taken from Catalog DA93.1.

### 6.7.2 Fuses

| Converter<br><br>Order No. | Type designation           | Line fuse    |                    | DC fuse<br>(2 fuses connected in parallel) |                    |
|----------------------------|----------------------------|--------------|--------------------|--|--------------------|
|                            |                            | Order No.    | Rated DC current A | Order No.                                  | Rated DC current A |
| 6RA2487-6DS22-0            | D485 / 850 Mre - GeEF6S22  | 3NE3338-8 1) | 800                | —  | —                  |
| 6RA2487-6GS22-0            | D600 / 850 Mre - GeEF6S22  | 3NE3338-8    | 800                | —  | —                  |
| 6RA2487-6DV62-0            | D485 / 850 Mreq - GeGF6V62 | 3NE3338-8    | 800                | 3NE3335 1)                                 | 560                |
| 6RA2487-6GV62-0            | D520 / 850 Mreq - GeGF6V62 | 3NE3338-8    | 800                | 3NE3335                                    | 560                |
| 6RA2487-6DS00-0            | B6C 400/540-850G001        | 3NE3338-8    | 800                | —  | —                  |
| 6RA2487-6GS00-0            | B6C 500/675-850G001        | 3NE3338-8    | 800                | —  | —                  |
| 6RA2487-6DV00-0            | (B6)A(B6)C 500/675-850G001 | 3NE3338-8    | 800                | 3NE3335                                    | 560                |
| 6RA2487-6GV00-0            | (B6)A(B6)C 500/675-850G001 | 3NE3338-8    | 800                | 3NE3335                                    | 560                |

1) Fuse holder : 3NH3430

Recommended field fuses: 5SD480 / rated current 30 A

# **SIEMENS**

## **SIMOREG K**

**6RA24 converters with microprocessor,  
from 6kW to 774kW in a B6C fully-controlled  
tree-phase bridge circuit and  
circulating current-free, anti-parallel circuit  
(B6)A(B6)C for DC variable-speed drives**

## **Instruction Manual**

Order-No.: 6RX1240-0AD76

**Converter software release: starting with 2.00**

**March 1994 Edition**

## **IMPORTANT INFORMATION**

This Instruction Manual includes information regarding the mode of operation of the converter using software release 2.00. Although this Instruction Manual can be generally used for all previous software releases, specific parameter code and fault code definitions in these instructions, under certain circumstances, go beyond the information in previous software releases or are contrary to these.

This Instruction Manual does not claim to cover all equipment details and versions or to take into account every conceivable situation regarding the installation, operation or maintenance of the equipment. If additional information is required or if special problems occur, which are not handled in enough detail in these instructions, please contact the local Siemens representative.

## **NOTE**

The contents of this Instruction Manual does not change any previous or existing contract, agreement, or contractual liability. All of the responsibilities of the Siemens ASI 1 Drive Technology Group are specified in detail in the purchase contract which exclusively specifies all of the warranty conditions. This contractual warranty agreement is neither expanded nor restricted by the information contained in this Instruction Manual.

This publication was produced on the Siemens  
5822 Office System

Subject to change without prior notice

The reproduction, transmission or use of this document  
or contents is not permitted without express written authority.  
Offenders will be liable for damages. All rights, including  
rights created by patent grant or registration of a utility  
model or design, are reserved

© Siemens AG 1992



## Contents

|  | Page  |
|--|-------|
| <b>1. Safety information</b>   | 1/ 1  |
| <b>2. Type spectrum</b>  | 2/ 1  |
| 2.1 Converter Order No. code   | 2/ 4  |
| 2.2 Ordering information for options using codes   | 2/ 5  |
| <b>3. Description</b>  | 3/ 1  |
| 3.1 Applications   | 3/ 1  |
| 3.2 Design   | 3/ 1  |
| 3.3 Mode of operation  | 3/ 2  |
| 3.4 Technical data   | 3/ 3  |
| 3.5 Applicable standards   | 3/ 10 |
| 3.6 Abbreviations  | 3/ 10 |
| <b>4. Transport, unpacking</b>   | 4/ 1  |
| 4.1 Damage during transport  | 4/ 1  |
| 4.1.1 Procedure for transport damage   | 4/ 1  |
| 4.1.2 Transport insurance  | 4/ 2  |
| <b>5. Installation</b>   | 5/ 1  |
| 5.1 Dimension drawings   | 5/ 6  |
| 5.2 Position of PC boards, ribbon cables and terminal strips   | 5/ 13 |
| 5.3 Installing the software board and options  | 5/ 16 |
| 5.3.1 Software board   | 5/ 16 |
| 5.3.2 Converter operator control panel (Order No.: 6RX1240-0AP20)  | 5/ 17 |
| 5.3.3 CS51 (Order No.: 6DD1660-0AH1), PT10 (Order No.: 6DD3440-0AB3)   | 5/ 18 |
| 5.3.3.1 Installing supplementary boards for 30A to 1200A converters  | 5/ 18 |
| 5.3.3.2 Mounting unit for mounting supplementary boards on the 15A converter (Order No.: 6RX1240-0AM75)                            | 5/ 19 |
| 5.3.4 Motor interface (Order No.: 6RX1240-0AL00)   | 5/ 20 |
| 5.3.5 Interface expansion (Order No.: 6RX1240-0AL01)   | 5/ 21 |
| 5.3.6 Two-tier configuration of motor interface and interface expansion in the SIMOREG converter (mounting set No.: 6RX1240-0AM74) | 5/ 22 |
| 5.3.7 Mounting the terminal block and motor interface outside the converter  | 5/ 23 |

|   | Page        |
|---|-------------|
| <b>6. Connecting-up</b>   | <b>6/ 1</b> |
| 6.1 Instructions for connecting screened control cables   | 6/ 2        |
| 6.2 Block diagrams with recommended connection  | 6/ 5        |
| 6.3 Connecting a SIMOREG converter in parallel with a 6QG35 SITOR thyristor set                           | 6/ 8        |
| 6.4 Power connections   | 6/ 9        |
| 6.5 Field supply  | 6/ 16       |
| 6.6 Load and shunt resistors (location, refer to the subsequent pages)                                    | 6/ 18       |
| 6.7 Fuses and commutating reactors  | 6/ 23       |
| 6.7.1 Commutating reactors  | 6/ 23       |
| 6.7.2 Fuses   | 6/ 23       |
| 6.8 Terminal connecting diagram   | 6/ 25       |
| 6.8.1 Settings  | 6/ 28       |
| 6.9 Terminal assignment   | 6/ 30       |
| <br>  |             |
| <b>7. Start-up</b>  | <b>7/ 1</b> |
| 7.1 General safety information for start-up   | 7/ 1        |
| 7.2 Operator control panels   | 7/ 3        |
| 7.2.1 Simple operator control panel   | 7/ 3        |
| 7.2.2 Converter operator control panel  | 7/ 4        |
| 7.3 Procedure when parameterizing   | 7/ 9        |
| 7.3.1 Accessing technology board parameters   | 7/ 13       |
| 7.3.2 List of possible operator control panel displays  | 7/ 14       |
| 7.4 Reset to default value and adjust offset  | 7/ 17       |
| 7.5 Start-up steps  | 7/ 19       |
| 7.6 Manual optimization   | 7/ 28       |
| 7.6.1 Manual setting of the armature resistance $R_A$ (P110) and armature circuit inductance $L_A$ (P111) | 7/ 28       |
| 7.6.2 Manual setting of the field resistance $R_F$ (P112)   | 7/ 29       |

|  | Page   |
|--|--------|
| <b>8. Operation</b>                                      | 8/ 1   |
| 8.1 Operating statuses                                   | 8/ 1   |
| 8.2 Fault messages                                       | 8/ 3   |
| 8.2.1 Fault overview                                     | 8/ 5   |
| 8.2.2 Fault description                                  | 8/ 8   |
| 8.2.2.1 Supply faults                                    | 8/ 8   |
| 8.2.2.2 Interface errors                                 | 8/ 12  |
| 8.2.2.3 Drive faults                                     | 8/ 17  |
| 8.2.2.4 Start-up faults                                  | 8/ 23  |
| 8.2.2.5 Fault messages from the thyristor check function | 8/ 34  |
| 8.2.2.6 Internal faults                                  | 8/ 36  |
| 8.2.2.7 Fault messages from the motor sensor system      | 8/ 41  |
| 8.2.2.8 External faults                                  | 8/ 42  |
| 8.2.3 Acknowledging fault messages                       | 8/ 44  |
| 8.2.4 Disabling/activating monitoring functions          | 8/ 44  |
| 8.3 Alarms   | 8/ 44  |
| 8.3.1 Alarm displays                                     | 8/ 45  |
| 8.3.2 Alarm list   | 8/ 46  |
| <br>   |        |
| <b>9. Parameter list</b>                                 | 9/ 1   |
| 9.1 Parameter overview                                   | 9/ 1   |
| 9.2 Parameter description                                | 9/ 21  |
| 9.3 Global converter parameters                          | 9/ 137 |
| <br>   |        |
| <b>10. Functions</b>                                     | 10/ 1  |
| 10.1 Function diagrams                                   | 10/ 9  |
| 10.2 List of connectors                                  | 10/ 29 |
| 10.3 Binary input functions                              | 10/ 37 |
| 10.3.1 Reserved for later use                            | 10/ 41 |
| 10.3.2 Shutdown button                                   | 10/ 41 |
| 10.3.3 Voltage disconnect (OFF2)                         | 10/ 41 |
| 10.3.4 Fast stop (OFF3)                                  | 10/ 42 |
| 10.3.5 Fault acknowledgement (as supplied, terminal 36)  | 10/ 43 |
| 10.3.6 Enable technology controller                      | 10/ 43 |
| 10.3.7 Enable speed controller                           | 10/ 44 |
| 10.3.8 Enable EMF controller                             | 10/ 44 |

|   | Page   |
|---|--------|
| 10.3.9 Ramp-function generator enable   | 10/ 44 |
| 10.3.10 Ramp-function generator stop  | 10/ 44 |
| 10.3.11 Setpoint enable   | 10/ 45 |
| 10.3.12 Wobulation enable (oscillation)   | 10/ 45 |
| 10.3.13 Inching   | 10/ 45 |
| 10.3.14 Inching and bypass ramp-function generator                                  | 10/ 46 |
| 10.3.15 Crawl   | 10/ 46 |
| 10.3.16 Crawl and bypass ramp-function generator                                    | 10/ 47 |
| 10.3.17 Fixed setpoint  | 10/ 47 |
| 10.3.18 Fixed setpoint and bypass ramp-function generator                           | 10/ 48 |
| 10.3.19 Supplementary setpoint before the technology controller                     | 10/ 48 |
| 10.3.20 Supplementary setpoint before the ramp-function generator                   | 10/ 48 |
| 10.3.21 Supplementary setpoint before the speed controller                          | 10/ 49 |
| 10.3.22 Supplementary setpoint before torque limiting                               | 10/ 49 |
| 10.3.23 Supplementary setpoint before the current controller                        | 10/ 49 |
| 10.3.24 Setpoint reduction  | 10/ 50 |
| 10.3.25 Motorized potentiometer, manual/automatic (switch)                          | 10/ 50 |
| 10.3.26 Motorized potentiometer, raise setpoint                                     | 10/ 50 |
| 10.3.27 Motorized potentiometer, lower setpoint                                     | 10/ 50 |
| 10.3.28 Motorized potentiometer, clockwise/counter-clockwise (switch)               | 10/ 50 |
| 10.3.29 Motorized potentiometer, clockwise (pushbutton)                             | 10/ 51 |
| 10.3.30 Motorized potentiometer, counter-clockwise (pushbutton)                     | 10/ 51 |
| 10.3.31 Ramp-function generator, setting 2 (P307 to P310)                           | 10/ 51 |
| 10.3.32 Ramp-function generator, setting 3 (P311 to P314)                           | 10/ 52 |
| 10.3.33, .34, .35 Use parameter set 2, 3, 4   | 10/ 52 |
| 10.3.36 Enable technology controller droop  | 10/ 53 |
| 10.3.37 Enable speed controller droop   | 10/ 53 |
| 10.3.38 Enable changeover, P/PI speed controller                                    | 10/ 54 |
| 10.3.39 Enable dv/dt input  | 10/ 54 |
| 10.3.40 Speed controller actual value polarity reversal                             | 10/ 54 |
| 10.3.41 Master/slave changeover   | 10/ 54 |
| 10.3.42 Torque limit changeover   | 10/ 55 |
| 10.3.43 Switching-in analog input "main setpoint" (terminals 4 and 5)               | 10/ 55 |
| 10.3.44 Switch-in the "main actual value" analog input (terminals 101, 102 and 103) | 10/ 56 |
| 10.3.45 Switch-in the "select input, analog 1", analog input (terminals 6 and 7)    | 10/ 56 |
| 10.3.46 Switch-in "select input, analog 2" analog input (terminal 8)                | 10/ 56 |
| 10.3.47 Switch-in "select input, analog 3" analog input (terminal 10)               | 10/ 56 |

|  | Page          |
|--|---------------|
| 10.3.48 "Main setpoint" analog input polarity (terminals 4 and 5)                                  | 10/ 56        |
| 10.3.49 "Main actual value" analog input polarity (terminals 101, 102 and 103)                     | 10/ 57        |
| 10.3.50 "Select input analog 1" analog input polarity (terminals 6 and 7)                          | 10/ 57        |
| 10.3.51 "Select input analog 2" analog input polarity (terminal 8)                                 | 10/ 57        |
| 10.3.52 "Select input analog 3" analog input polarity (terminal 10)                                | 10/ 57        |
| 10.3.53 External fault (low active)  | 10/ 57        |
| 10.3.54 External alarm (low active)  | 10/ 58        |
| 10.3.55 Operating enable due to the checkback signal "line contactor in"                           | 10/ 58        |
| 10.3.56 Standstill excitation  | 10/ 58        |
| 10.3.57 Direction of rotation reversal using field reversal  | 10/ 58        |
| 10.3.58 Braking with field reversal  | 10/ 59        |
| 10.3.59 $I_{\text{field external}} < I_{f_{\text{min}}}$   | 10/ 60        |
| 10.3.60 Enabling a torque direction for torque direction change for a parallel drive configuration | 10/ 61        |
| 10.3.61 Set binary select output 1   | 10/ 61        |
| 10.3.62 Set binary select output 2   | 10/ 62        |
| 10.3.63 Set binary select output 3   | 10/ 62        |
| 10.3.64 Set binary select output 4   | 10/ 62        |
| 10.3.65 Changeover command for the free changeover switch 1  | 10/ 62        |
| 10.3.66 Changeover command for the free changeover switch 2  | 10/ 62        |
| 10.3.67 Changeover command for the free changeover switch 3  | 10/ 63        |
| 10.3.68 Set motorized potentiometer  | 10/ 63        |
| 10.3.69 to reserved  | 10/ 63        |
| 10.3.89  |               |
| 10.3.90 Switch-on/shutdown (ON/OFF) terminal 37  | 10/ 63        |
| 10.3.91 Operating enable (OPER. ENAB.) terminal 38   | 10/ 65        |
| 10.3.92 Field current reduction (standstill excitation)  | 10/ 66        |
| 10.3.93 Safety shutdown (E-STOP)   | 10/ 66        |
| <b>10.4 Binary output functions</b>  | <b>10/ 67</b> |
| 10.4.3 Fault   | 10/ 69        |
| 10.4.4 Ready to switch-on (operating status o7)  | 10/ 69        |
| 10.4.5 Ready (operating status o1)   | 10/ 69        |
| 10.4.6 Run (operating status I , II or --)   | 10/ 69        |
| 10.4.7 Switch-on auxiliaries   | 10/ 70        |
| 10.4.8 Supply voltage (armature and field)   | 10/ 70        |
| 10.4.9 Line contactor control OFF (= switch-on inhibit)  | 10/ 70        |
| 10.4.10 Line contactor OFF (= E stop)  | 10/ 70        |

|                          | Page  |         |
|--------------------------|---|---------|
| 10.4.11                  | Checkback signal of the binary input function BEF55 (operating enable with the checkback signal "line contactor switched-in") | 10/ 71  |
| 10.4.12                  | Rump-function generator active  | 10/ 71  |
| 10.4.13                  | Counter-clockwise direction of rotation   | 10/ 71  |
| 10.4.14                  | Switch-on command for the holding- or operating brake   | 10/ 72  |
| 10.4.15                  | $I_A > I_X$ (Current limit value monitor)   | 10/ 75  |
| 10.4.16<br>to<br>10.4.21 | Speed limit value monitor   | 10/ 75  |
| 10.4.22                  | $n_{set}$ reached signal (speed controller monitoring)  | 10/ 76  |
| 10.4.23                  | $n < n_{excess}$  | 10/ 76  |
| 10.4.24                  | Alarm   | 10/ 76  |
| 10.4.25                  | Alarm "motor overload" (W01, W05, W06)  | 10/ 76  |
| 10.4.26                  | Alarm "converter overload"  | 10/ 77  |
| 10.4.27                  | Converter cooling faulted   | 10/ 77  |
| 10.4.28                  | $I_{field} < I_{f_{min}}$   | 10/ 77  |
| 10.4.29                  | $I_{Aset} = I_{limit}$ (actual current limit reached)   | 10/ 77  |
| 10.4.30                  | Switch-in field contactor 1   | 10/ 78  |
| 10.4.31                  | Close field contactor 2   | 10/ 78  |
| 10.4.32                  | Torque direction signal   | 10/ 78  |
| 10.4.33                  | Power section warm  | 10/ 79  |
| 10.4.34                  | Output of the freely-configurable limit value monitor 1   | 10/ 79  |
| 10.4.35                  | Output of the freely-configurable limit value monitor 2   | 10/ 79  |
| <b>10.5</b>              | <b>Control words</b>  | 10/ 80  |
| 10.5.1                   | Control word STW (K315)   | 10/ 80  |
| 10.5.2                   | Converter-specific, freely-definable control word STWF (K316)   | 10/ 81  |
| <b>10.6</b>              | <b>Status words</b>   | 10/ 85  |
| 10.6.1                   | Status word ZSW (K325)  | 10/ 85  |
| 10.6.2                   | Converter-specific status word ZSW1 (K326)  | 10/ 87  |
| 10.6.3                   | Converter-specific status word ZSW2 (K327)  | 10/ 88  |
| <b>10.7</b>              | <b>Serial interfaces</b>  | 10/ 89  |
| 10.7.1                   | Output of the parameter list, fault diagnostics memory and trace buffer   | 10/ 92  |
| 10.7.2                   | Reading-in parameters   | 10/ 94  |
| 10.7.3                   | USS protocol  | 10/ 96  |
| 10.7.4                   | "Peer-to-peer" protocol   | 10/ 98  |
| 10.7.4.1                 | "Peer-to-peer" communication (4-wire operation)   | 10/ 98  |
| 10.7.4.2                 | "Peer-to-peer" bus communication (2-wire operation)   | 10/ 99  |
| 10.7.5                   | Connecting cables   | 10/ 100 |

|              | Page   |         |
|--------------|--|---------|
| <b>10.8</b>  | <b>DC motor thermal overload protection (I2t motor monitoring)</b>                                       | 10/ 104 |
| <b>10.9</b>  | <b>Dynamic overload capability of the power section</b>  | 10/ 106 |
| 10.9.1       | Function overview  | 10/ 106 |
| 10.9.2       | Parameterization   | 10/ 106 |
| 10.9.3       | Configuring the dynamic overload capability  | 10/ 107 |
| 10.9.4       | Determining the dynamic overload capability for intermittent overload operation from the characteristics | 10/ 109 |
| <b>10.10</b> | <b>Recording connectors in a trace buffer as an aid to diagnostics</b>                                   | 10/ 116 |
| 10.10.1      | Output of values recorded in the trace buffer on a printer or transfer to a PC or a PG                   | 10/ 117 |
| 10.10.2      | Reading-out the contents of the trace buffer via the operator control panel                              | 10/ 117 |
| 10.10.3      | Output of the trace buffer contents via the analog select outputs  | 10/ 118 |
| <b>10.11</b> | <b>Speed-dependent current limiting</b>  | 10/ 118 |
| 10.11.1      | Setting the speed-dependent current limiting for motors with commutation transition                      | 10/ 119 |
| 10.11.2      | Setting the speed-dependent current limiting for motors without commutation transition                   | 10/ 120 |
| <b>10.12</b> | <b>Forcing</b>   | 10/ 121 |
| <b>10.13</b> | <b>Automatic re-start</b>  | 10/ 121 |
| <br>         |  |         |
| <b>11.</b>   | <b>Maintenance</b>   | 11/ 1   |
| 11.1         | Procedure when replacing software (upgrading to a new software release)                                  | 11/ 2   |
| <br>         |  |         |
| <b>12.</b>   | <b>Service</b>   | 12/ 1   |
| <br>         |  |         |
| <b>13.</b>   | <b>Spare parts</b>   | 13/ 1   |
| <br>         |  |         |
| <b>14.</b>   | <b>Appendix</b>  | 14/ 1   |
| 14.1         | Additional documentation   | 14/ 1   |
| <br>         |  |         |
| <b>15.</b>   | <b>SIMOVIS for 6RA24</b>   | 15/ 1   |
| 15.1         | What does SIMOVIS actually do  | 15/ 1   |
| 15.2         | Commissioning SIMOVIS  | 15/ 1   |
| 15.3         | Operator control   | 15/ 3   |
| 15.4         | Overview of the existing masks   | 15/ 7   |
| 15.5         | Troubleshooting  | 15/ 10  |

|   | Page           |
|---|----------------|
| <b>16. Installation instructions for EMC-correct installation of Drives</b>   | <b>16 / 1</b>  |
| <b>16.1 EMC basics</b>  | <b>16 / 1</b>  |
| 16.1.1 What is EMC  | 16 / 1         |
| 16.1.2 Noise radiation and noise immunity   | 16 / 1         |
| 16.1.3 Maximum values   | 16 / 2         |
| 16.1.4 SIMOREG K converters in industrial applications  | 16 / 2         |
| 16.1.5 Non-grounded supplies  | 16 / 2         |
| 16.1.6 EMC planning   | 16 / 3         |
| <b>16.2 EMC-correct installation/mounting of converters (installation instructions)</b>   | <b>16 / 3</b>  |
| 16.2.1 General information  | 16 / 3         |
| 16.2.2 Rules for EMC-correct installation   | 16 / 3         |
| 16.2.3 Converter component arrangement  | 16 / 12        |
| 16.2.4 List of the recommended radio interference suppression filters   | 16 / 13        |
| <b>16.3 Information on line-side harmonics generated by converters in a fully-controlled three-phase bridge circuit configuration</b> | <b>16 / 14</b> |



# 1. Safety information

|   |  |
|---|--|
|  | <p><b>WARNING</b></p> <hr/> <p>Hazardous voltages and rotating parts (fans) are present in this electrical equipment during operation.</p> <p>Non-observance of the safety instructions can result in severe personal injury or property damage.</p> <p>Only qualified personnel should work on or around the equipment after first becoming thoroughly familiar with all warning and safety notices and maintenance procedures contained herein.</p> <p>The successful and safe operation of this equipment is dependent on proper handling, installation, operation and maintenance.</p> |
|---|--|

## Definitions:

### QUALIFIED PERSONNEL

For the purpose of this Instruction Manual and product labels, a "Qualified person" is someone who is familiar with the installation, construction and operation of the equipment and the hazards involved. He or she must have the following qualifications:

1. Trained and authorized to energize, de-energize, clear, ground and tag circuits and equipment in accordance with established safety procedures.
2. Trained in the proper care and use of protective equipment in accordance with established safety procedures.
3. Trained in rendering first aid

### DANGER

For the purpose of this Instruction Manual and product labels, "Danger" indicates death, severe personal injury or substantial property damage will result if proper precautions are not taken.

### WARNING

For the purpose of this Instruction Manual and product labels, "Warning" indicates death, severe personal injury or substantial property damage can result if proper precautions are not taken.

### CAUTION

For the purpose of this Instruction Manual and product labels, "Caution" indicates minor personal injury or property damage can result if proper precautions are not taken.

### NOTE

For the purpose of this Instruction Manual, "Note" indicates information about the product or the respective part of the Instruction Manual which is essential to highlight.



## DANGER

Converters contain hazardous electrical voltages. Death, severe bodily injury or significant material damage will occur if the safety measures are not followed.

1. Only qualified personnel, who are knowledgeable about the converters and the provided information, can install, start-up, operate, troubleshoot or repair the converters.
2. The converters must be installed in accordance with all relevant safety regulations (e.g. DIN VDE) as well as all other national or local regulations. Operational safety and reliability must be ensured by correct grounding, cable dimensioning and appropriate short-circuit protection.
3. All panels and doors must be kept closed during normal operation.
4. Before carrying out visual checks and maintenance work ensure that the AC power supply is disconnected and locked-out. Before the AC supply is disconnected, both converters and motors have hazardous voltage levels. Even when the converter contactor is open, hazardous voltages are still present.
5. When making measurements with the power supply switched-on, under no circumstances should electrical connections be touched. Remove all jewelry from wrists and fingers. Ensure that the test equipment is in good condition and is operationally safe.
6. When working on units which are switched-on, stand on an insulating surface, i.e. ensure that you are not grounded.
7. Carefully follow the relevant instructions and observe all danger-, warning- and cautionary notes.
8. This does not represent a full listing of all the measures necessary for safe operation of the equipment. If you require other information or if certain problems occur which are not handled in enough detail in the information provided in the Instruction Manual, please contact your local Siemens office.



## 2. Type spectrum

| Converter Order No. | Type designation          |
|---------------------|---------------------------|
| 6RA2418 - 6DS22 - 0 | D485 / 30 Mre - GeE6S22   |
| 6RA2425 - 6DS22 - 0 | D485 / 60 Mre - GeE6S22   |
| 6RA2428 - 6DS22 - 0 | D485 / 90 Mre - GeE6S22   |
| 6RA2431 - 6DS22 - 0 | D485 / 125 Mre - GeE6S22  |
| 6RA2418 - 6GS22 - 0 | D600 / 30 Mre - GeE6S22   |
| 6RA2425 - 6GS22 - 0 | D600 / 60 Mre - GeE6S22   |
| 6RA2428 - 6GS22 - 0 | D600 / 90 Mre - GeE6S22   |
| 6RA2431 - 6GS22 - 0 | D600 / 125 Mre - GeE6S22  |
| 6RA2413 - 6DV62 - 0 | D420 / 15Mreq - GeG6V62   |
| 6RA2418 - 6DV62 - 0 | D420 / 30 Mreq - GeG6V62  |
| 6RA2425 - 6DV62 - 0 | D420 / 60 Mreq - GeG6V62  |
| 6RA2430 - 6DV62 - 0 | D420 / 100 Mreq - GeG6V62 |
| 6RA2432 - 6DV62 - 0 | D420 / 140 Mreq - GeG6V62 |
| 6RA2418 - 6GV62 - 0 | D520 / 30 Mreq - GeG6V62  |
| 6RA2425 - 6GV62 - 0 | D520 / 60 Mreq - GeG6V62  |
| 6RA2430 - 6GV62 - 0 | D520 / 100 Mreq - GeG6V62 |
| 6RA2432 - 6GV62 - 0 | D520 / 140 Mreq - GeG6V62 |

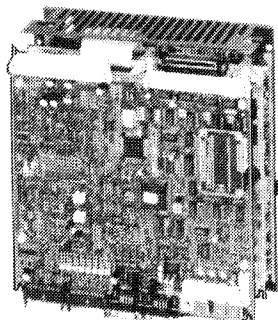
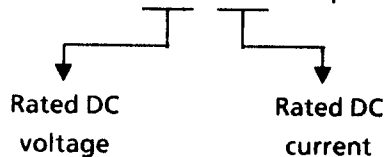

15A Converter

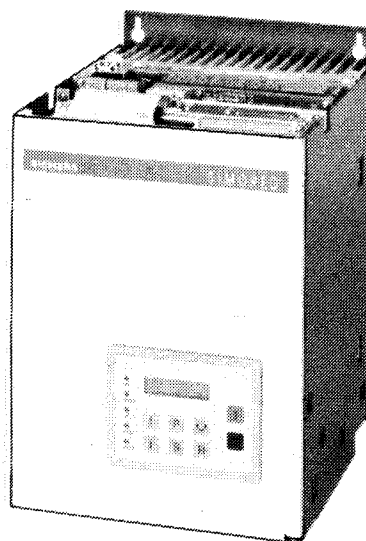
Converter 30 to 140A  
without fan

| Converter Order No. | Type designation           |
|---------------------|----------------------------|
| 6RA2475 - 6DS22 - 0 | D485 / 200 Mre - GeEF6S22  |
| 6RA2477 - 6DS22 - 0 | D485 / 250 Mre - GeEF6S22  |
| 6RA2481 - 6DS22 - 0 | D485 / 400 Mre - GeEF6S22  |
| 6RA2485 - 6DS22 - 0 | D485 / 600 Mre - GeEF6S22  |
| 6RA2475 - 6GS22 - 0 | D600 / 200 Mre - GeEF6S22  |
| 6RA2477 - 6GS22 - 0 | D600 / 250 Mre - GeEF6S22  |
| 6RA2481 - 6GS22 - 0 | D600 / 400 Mre - GeEF6S22  |
| 6RA2485 - 6GS22 - 0 | D600 / 600 Mre - GeEF6S22  |
| 6RA2475 - 6DV62 - 0 | D420 / 200 Mreq - GeGF6V62 |
| 6RA2477 - 6DV62 - 0 | D420 / 250 Mreq - GeGF6V62 |
| 6RA2481 - 6DV62 - 0 | D420 / 400 Mreq - GeGF6V62 |
| 6RA2485 - 6DV62 - 0 | D420 / 600 Mreq - GeGF6V62 |
| 6RA2475 - 6GV62 - 0 | D520 / 200 Mreq - GeGF6V62 |
| 6RA2477 - 6GV62 - 0 | D520 / 250 Mreq - GeGF6V62 |
| 6RA2481 - 6GV62 - 0 | D520 / 400 Mreq - GeGF6V62 |
| 6RA2485 - 6GV62 - 0 | D520 / 600 Mreq - GeGF6V62 |

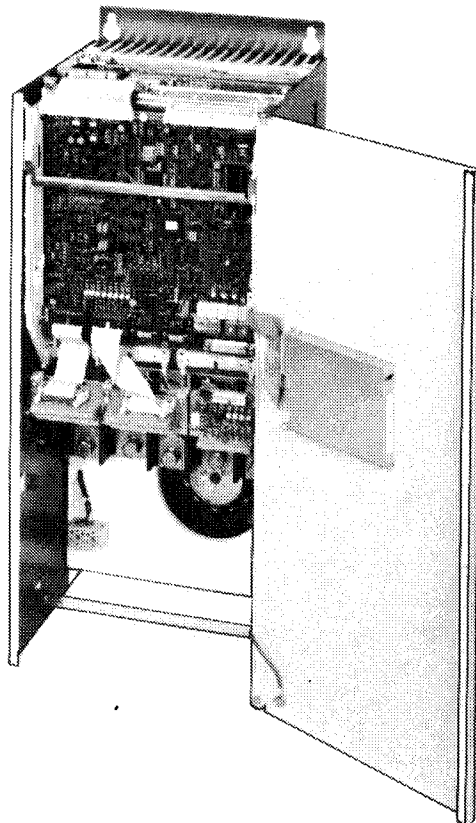
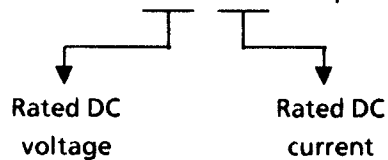

Converter 200 to 600A  
with fan

| Converter Order No. | Type designation            |
|---------------------|-----------------------------|
| 6RA2487 - 4DS22 - 0 | D485 / 850 Mre - GeEF4S22   |
| 6RA2491 - 4DS22 - 0 | D485 / 1200 Mre - GeEF4S22  |
| 6RA2487 - 4DV62 - 0 | D420 / 850 Mreq - GeGF4V62  |
| 6RA2491 - 4DV62 - 0 | D420 / 1200 Mreq - GeGF4V62 |
| 6RA2487 - 4GS22 - 0 | D600 / 850 Mre - GeEF4S22   |
| 6RA2491 - 4GS22 - 0 | D600 / 1200 Mre - GeEF4S22  |
| 6RA2487 - 4GV62 - 0 | D520 / 850 Mreq - GeGF4V62  |
| 6RA2491 - 4GV62 - 0 | D520 / 1200 Mreq - GeGF4V62 |
| 6RA2485 - 4KS22 - 0 | D900 / 640 Mre - GeEF4S22   |
| 6RA2487 - 4KS22 - 0 | D900 / 860 Mre - GeEF4S22   |
| 6RA2485 - 4KV62 - 0 | D790 / 640 Mreq - GeGF4V62  |
| 6RA2487 - 4KV62 - 0 | D790 / 860 Mreq - GeGF4V62  |

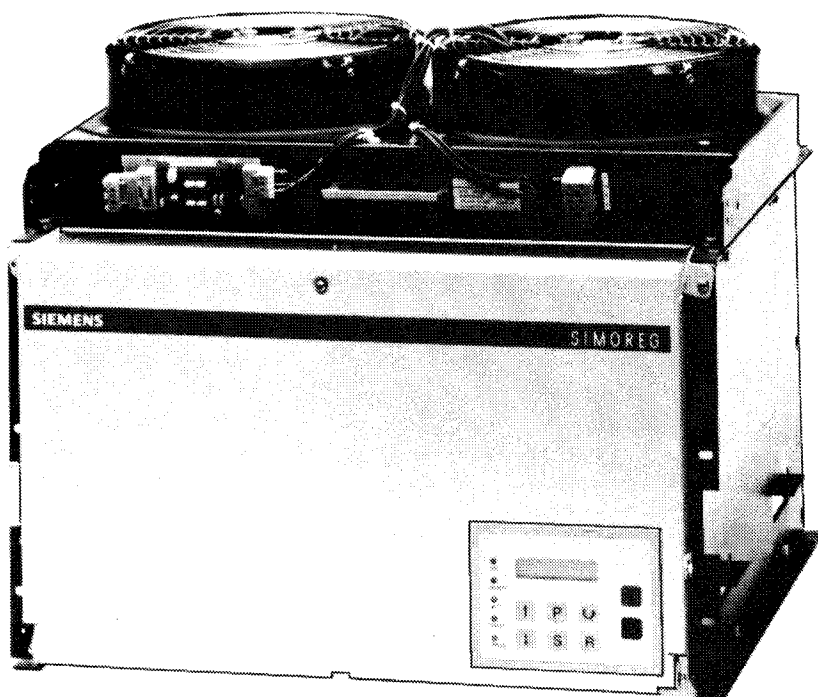
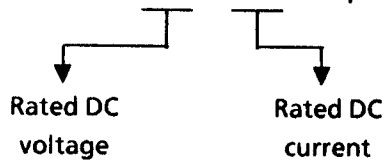

Converter > 600A  
with fan

## 2.1 Converter Order No. code

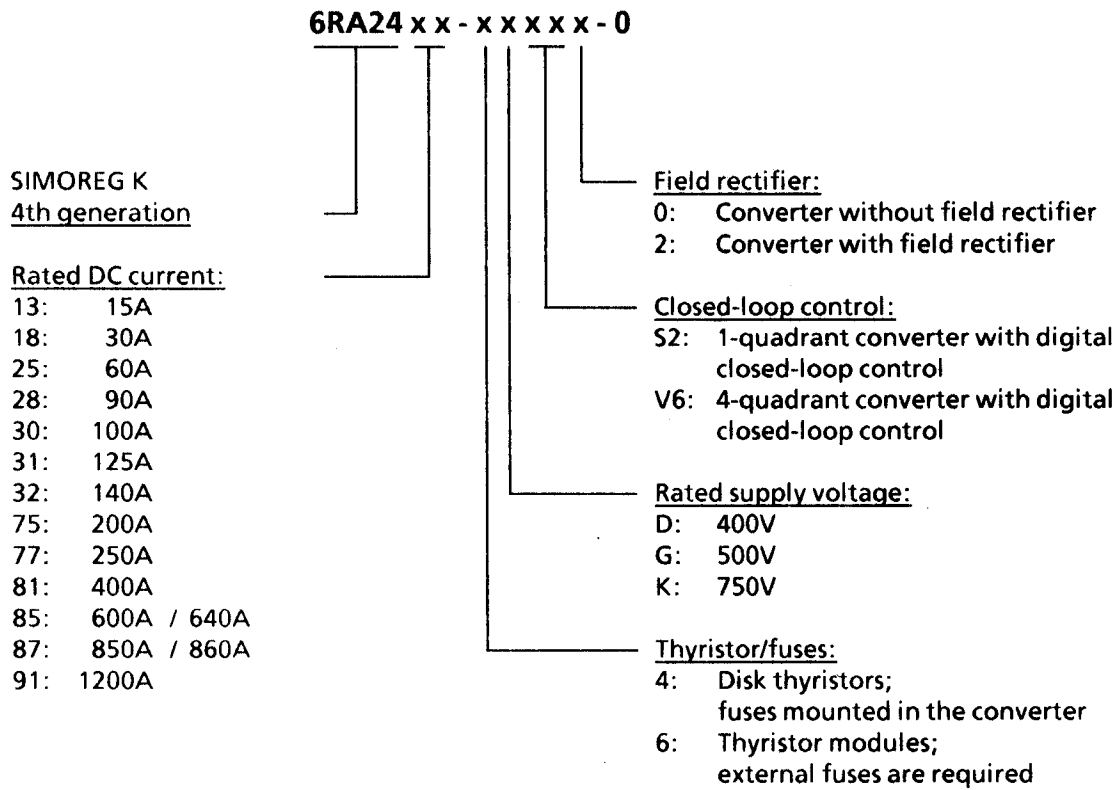

## 2.2 Ordering information for options using codes

6 R A 2    -     - 0 - Z SIMOREG converter Order No. with suffix Z and

+    +    codes (several codes together) and/or

if required, plain text.

| Options  | Codes | Order No.     |
|--|-------|---------------|
| Documentation, German (standard)   | -     | 6RX1240-0AD00 |
| Documentation, Italian   | D72   | 6RX1240-0AD72 |
| Documentation, English   | D76   | 6RX1240-0AD76 |
| Documentation, French  | D77   | 6RX1240-0AD77 |
| Documentation, Spanish   | D78   | 6RX1240-0AD78 |
| Motor interface  | L00   | 6RX1240-0AL00 |
| Interface expansion  | L01   | 6RX1240-0AL01 |
| SIMOREG converter for field supply   | L03   | -             |
| Anti-condensation heating  | M08   | -             |
| Long cable for terminal block  | M70   | 6RX1240-0AM70 |
| Long cable for motor interface   | M73   | 6RX1240-0AM73 |
| Mounting set for two-tier mounting of the motor interface and interface expansion in the SIMOREG converter | M74   | 6RX1240-0AM74 |
| Mounting unit for supplementary boards for 15 A converters   | M75   | 6RX1240-0AM75 |
| SIMOREG converters for >600 A without fan for 2-tier mounting  | M80   | -             |
| Converter operator control panel   | P20   | 6RX1240-0AP20 |
| Operator control panel, German (standard)  | -     | 6RX1240-0AS00 |
| Operator control panel, Italian *)   | S72   | 6RX1240-0AS72 |
| Operator control panel, English *)   | S76   | 6RX1240-0AS76 |
| Operator control panel, French *)  | S77   | 6RX1240-0AS77 |
| Operator control panel, Spanish *)   | S78   | 6RX1240-0AS78 |

\*) Only necessary for the "P20" converter control panel option





## 3. Description

### 3.1 Applications

6RA24 SIMOREG K converters are fully-digital compact units for three-phase supply and are used for supplying the armature and field of variable-speed DC motors with rated armature currents or 15A to 1200 A. Currents up to 3600 A are possible by connecting SITOR sets in parallel with the compact converters. Field supply is possible for currents up to 30A (current levels depending on the armature rated current).

There are converters for both single-quadrant and four-quadrant operation, depending on the particular application.

### 3.2 Design

SIMOREG K converters are extremely compact. The 15A units can either be mounted flat onto the mounting panel in the cubicle, on end to save space, or mounted in withdrawable racks. The modular design provides a high level of service friendliness as the individual components are easily accessible. The electronics box accommodates the basic electronics as well as any supplementary boards, and can be easily swung-out or removed.

External signals (binary inputs/outputs, analog inputs/outputs, pulse encoder, etc.) are not connected to the basic electronics board, but to a separate installed terminal module. Two ribbon cables are used to transfer signals between the basic electronics board and the terminal module. Two, 2 meter screened cables are optionally available (Order No. 6RX1240-0AM70), so that the terminal module can also be mounted outside the converter in a cubicle at any position (refer to Section 5.3.6 and 6.1).

Four analog inputs, five analog outputs, eight binary inputs and four binary outputs are available.

The equipment software is provided in a plug-in EPROM module, which can be easily replaced.

SIMOREG converters can be parameterized using the three keys and five 7-segment displays on the simple operator control panel on the electronics board. They are also prepared so that a converter operator panel can be mounted (Order 6RX1249-0AP20), to support parameterization using plain text, or to be able to simultaneously display up to monitored variables. The converter can also be parameterized using the RS 232 interface on the electronics board with a conventional PC and suitable software. This PC interface is used for start-up, maintenance/service when shutdown, or for troubleshooting during operation, and is thus a service interface.

For single-quadrant converters, the armature is supplied using a fully-controlled three-bridge, and for four quadrant converters, using two fully-controlled three-phase bridges in a circulating-current free, anti-parallel circuit configuration.

The field is supplied through a single-phase branch-pair half-controlled 2-pulse bridge circuit (B2HZ).

The armature and field supply voltage frequencies can be different (in the range from 45 to 65 Hz). The armature circuit supply phase sequence is insignificant.

For converters with 15 A rated DC current, the power section, including gating is mounted on a PC board.

For converters with rated DC currents 15 A to 600 A, the power section for armature and field uses isolated thyristor modules, and thus the heatsink is electrically isolated. The housing and terminal covers of the power connections provide protection against accidental contact when working in the vicinity of the converters. All connecting terminals are accessible from the front.

For converters with rated DC currents between 640A and 1200A, the power section consists of six SITOR blocks, arranged in a mechanical structure in a withdrawable rack design. The basic structure consists of a rack with insulating components and busbars for accepting the 6 SITOR blocks. The power connections of the SITOR block are located at the rear. The electronics is mounted on the front side of the block in such a fashion that it can be swung-out.

### **3.3 Mode of operation**

All open-loop and closed-loop drive control functions and communications are realized by a powerful 16-bit microprocessor.

The rated DC currents specified on the converter rating plate (continuous DC currents) can be overloaded by 150 %, whereby the overload duration is dependent on the particular converter. The microprocessor cyclically calculates the actual  $I^2t$  value of the power section, so that when the converter is overloaded, the thyristors are not damaged.

A selection table for overload operation is provided in Section 10 "Functions".

## 3.4 Technical data

## 30A to 600A converters, 3-ph. AC 400V / 1Q

|  |   |     |     |     |  |     |      |      |  |
|--|---|-----|-----|-----|--|-----|------|------|--|
| Order No.  | 6RA24... - 6DS22  |     |     |     |  |     |      |      |  |
|  | 18  | 25  | 28  | 31  | 75   | 77  | 81   | 85   |  |
| Rated supply voltage armature V                  | 3-ph. AC 400 (+ 15% / - 20%) <sup>1)</sup>  |     |     |     |  |     |      |      |  |
| Rated supply voltage electronics power supply V  | 2-ph. AC 400 (+ 15% / - 25%); I <sub>n</sub> = 0,5A<br>(- 35% for 1min)   |     |     |     |  |     |      |      |  |
| Rated supply voltage fan V                       |   |     |     |     | 3-ph. AC 400 (± 15%);<br>0,24A, 95Watt<br>Air flow: 570m <sup>3</sup> /h<br>Fan noise: 63dBA |     |      |      |  |
| Rated supply voltage field V                     | 2-ph. AC 400 (+ 15% / - 20%)  |     |     |     |  |     |      |      |  |
| Rated frequency Hz                               | Converters automatically adapt themselves to the frequency of the available supply voltage in the range from 45 to 65 Hz (Armature and field are independent).  |     |     |     |  |     |      |      |  |
| Rated DC voltage V                               | 485   |     |     |     |  |     |      |      |  |
| Rated DC current A                               | 30  | 60  | 90  | 125 | 200  | 250 | 400  | 600  |  |
| Overload capability                              | max. 150% rated DC current  |     |     |     |  |     |      |      |  |
| Rated output kW                                  | 15  | 29  | 44  | 61  | 97   | 121 | 194  | 291  |  |
| Power loss at rated DC current (approx.) W       | 140   | 230 | 320 | 440 | 650  | 800 | 1250 | 1850 |  |
| Rated DC voltage field V                         | max. 325  |     |     |     |  |     |      |      |  |
| Rated DC current field A                         | 5   | 10  |     |     | 15   |     | 25   |      |  |
| Operational ambient temperature °C               | 0 to 45 at I <sub>rated</sub> self-ventilated <sup>3)</sup>   |     |     |     | 0 to 35 at I <sub>rated</sub> forced-cooled <sup>3)</sup>                                    |     |      |      |  |
| Storage and transport temperature °C             | - 30 to + 85  |     |     |     |  |     |      |      |  |
| Installation altitude above sea level            | ≤ 1000 m at rated DC current <sup>4)</sup>  |     |     |     |  |     |      |      |  |
| Control stability                                | Δn = 0.006% of the motor rated speed, is valid for pulse encoder operation and digital setpoint.<br>Δn = 0.1% of the rated motor speed is valid for analog tachometer or analog setpoint. <sup>2)</sup> |     |     |     |  |     |      |      |  |
| Humidity classification<br>DIN 40040<br>SN 26556 | F   |     |     |     |  |     |      |      |  |
| Deg. of prot.<br>DIN 40050<br>IEC 144            | IP 00   |     |     |     |  |     |      |      |  |
| Dimensions                                       | refer to dimension drawings   |     |     |     |  |     |      |      |  |
| Weight (approx.) kg                              | 11  | 14  | 14  | 16  | 23   | 23  | 31   | 31   |  |

Explanation of the footnotes after the tables

## 15A to 600A converters, 3-ph. AC 400V / 4Q

|  |   |      |     |     |     |  |     |      |      |  |
|--|---|------|-----|-----|-----|--|-----|------|------|--|
| Order No.  | 6RA24 ... - 6DV62   |      |     |     |     |  |     |      |      |  |
|  | 13  | 18   | 25  | 30  | 32  | 75   | 77  | 81   | 85   |  |
| Rated supply voltage armature V                  | 3-ph. AC 400 (+ 15% / - 20%) <sup>1)</sup>  |      |     |     |     |  |     |      |      |  |
| Rated supply voltage electronics power supply V  | 2-ph. AC 400 (+ 15% / - 25%); I <sub>n</sub> = 0,5A);<br>(- 35% for 1min)   |      |     |     |     |  |     |      |      |  |
| Rated supply voltage Fan V                       | 3-ph. AC 400 (± 15%);<br>0,24A, 95Watt<br>Air flow: 570m <sup>3</sup> / h<br>Fan noise: 63dBA   |      |     |     |     |  |     |      |      |  |
| Rated supply voltage field V                     | 2-ph. AC 400 (+ 15% / - 20%)  |      |     |     |     |  |     |      |      |  |
| Rated frequency Hz                               | Converters automatically adapt themselves to the frequency of the available supply voltage in the range from 45 to 65 Hz (Armature and field are independent).  |      |     |     |     |  |     |      |      |  |
| Rated DC voltage V                               | 420   |      |     |     |     |  |     |      |      |  |
| Rated DC current A                               | 15  | 30   | 60  | 100 | 140 | 200  | 250 | 400  | 600  |  |
| Overload capability                              | max. 150% rated DC current  |      |     |     |     |  |     |      |      |  |
| Rated output kW                                  | 6,3   | 12,6 | 25  | 42  | 59  | 84   | 105 | 168  | 252  |  |
| Power loss at rated DC current (approx.) W       | 80  | 140  | 230 | 320 | 440 | 650  | 800 | 1250 | 1850 |  |
| Rated DC voltage field V                         | max. 325  |      |     |     |     |  |     |      |      |  |
| Rated DC current field A                         | 3   | 5    | 10  |     |     | 15   |     | 25   |      |  |
| Operational ambient temperature °C               | 0 to 45 at I <sub>rated</sub> self-ventilated 3)  |      |     |     |     | 0 to 35 at I <sub>rated</sub> forced-cooled 3) |     |      |      |  |
| Storage and transport temperature °C             | - 30 to + 85  |      |     |     |     |  |     |      |      |  |
| Installation altitude above sea level            | ≤ 1000 m at rated DC current <sup>4)</sup>  |      |     |     |     |  |     |      |      |  |
| Control stability                                | Δn = 0.006% of the motor rated speed,<br>is valid for pulse encoder operation <u>and</u> digital setpoint<br>Δn = 0.1% of the rated motor speed,<br>is valid for analog tachometer or analog setpoint <sup>2)</sup> |      |     |     |     |  |     |      |      |  |
| Humidity classification<br>DIN 40040<br>SN 26556 | F   |      |     |     |     |  |     |      |      |  |
| Deg. of prot. DIN 40050<br>IEC 144               | IP 00   |      |     |     |     |  |     |      |      |  |
| Dimensions                                       | refer to dimension drawings   |      |     |     |     |  |     |      |      |  |
| Weight (approx.) kg                              | 3,5   | 11   | 14  | 14  | 16  | 23   | 23  | 31   | 31   |  |

Explanation of the footnotes after the tables

## 30A to 600A converters, 3-ph. AC 500V / 1Q

|  |   |     |     |     |  |     |      |      |  |
|--|---|-----|-----|-----|--|-----|------|------|--|
| Order No.  | 6RA24... - 6GS22  |     |     |     |  |     |      |      |  |
|  | 18  | 25  | 28  | 31  | 75   | 77  | 81   | 85   |  |
| Rated supply voltage armature V                  | 3-ph. AC 500 (+ 10% / - 15%) 1)   |     |     |     |  |     |      |      |  |
| Rated supply voltage electronics power supply V  | 2-ph. AC 400 (+ 15% / - 25%); I <sub>n</sub> = 0,5A<br>(- 35% for 1min)   |     |     |     |  |     |      |      |  |
| Rated supply voltage fan V                       |   |     |     |     | 3-ph. AC 400 (± 15%);<br>0,24A, 95Watt<br>Air flow: 570m <sup>3</sup> /h<br>Fan noise: 63dBA |     |      |      |  |
| Rated supply voltage field V                     | 2-ph. AC 400 (+ 15% / - 20%)  |     |     |     |  |     |      |      |  |
| Rated frequency Hz                               | Converters automatically adapt themselves to the frequency of the available supply voltage in the range from 45 to 65 Hz (Armature and field are independent).                              |     |     |     |  |     |      |      |  |
| Rated DC voltage V                               | 600   |     |     |     |  |     |      |      |  |
| Rated DC current A                               | 30  | 60  | 90  | 125 | 200  | 250 | 400  | 600  |  |
| Overload capability                              | max. 150% rated DC current  |     |     |     |  |     |      |      |  |
| Rated output kW                                  | 18  | 36  | 54  | 75  | 120  | 150 | 240  | 360  |  |
| Power loss at rated DC current (approx.) W       | 140   | 230 | 320 | 440 | 650  | 800 | 1250 | 1850 |  |
| Rated DC voltage field V                         | max. 325  |     |     |     |  |     |      |      |  |
| Rated DC current field A                         | 5   | 10  |     |     | 15   |     | 25   |      |  |
| Operational ambient temperature °C               | 0 to 45 at I <sub>rated</sub> self-ventilated 3)  |     |     |     | 0 to 35 at I <sub>rated</sub> forced-cooled 3)   |     |      |      |  |
| Storage and transport temperature °C             | - 30 to + 85  |     |     |     |  |     |      |      |  |
| Installation altitude above sea level            | ≤ 1000 m at rated DC current 4)   |     |     |     |  |     |      |      |  |
| Control stability                                | Δn = 0.006% of the motor rated speed, is valid for pulse encoder operation and digital setpoint<br>■n = 0.1% of the rated motor speed, is valid for analog tachometer or analog setpoint 2) |     |     |     |  |     |      |      |  |
| Humidity classification<br>DIN 40040<br>SN 26556 | F   |     |     |     |  |     |      |      |  |
| Deg. of prot.<br>DIN 40050<br>IEC 144            | IP 00   |     |     |     |  |     |      |      |  |
| Dimensions                                       | refer to dimension drawings   |     |     |     |  |     |      |      |  |
| Weight (approx.) kg                              | 11  | 14  | 14  | 16  | 23   | 23  | 31   | 31   |  |

Explanation of the footnotes after the tables

## 30A to 600A converters, 3-ph. AC 500V / 4Q

|  |   |     |     |     |     |  |      |      |  |
|--|---|-----|-----|-----|-----|--|------|------|--|
| Order No.  | 6RA24... - 6GV62  |     |     |     |     |  |      |      |  |
|  | 18  | 25  | 30  | 32  | 75  | 77   | 81   | 85   |  |
| Rated supply voltage armature V                  | 3-ph. AC 500 (+ 10% / - 15%) <sup>1)</sup>  |     |     |     |     |  |      |      |  |
| Rated supply voltage electronics power supply V  | 2-ph. AC 400 (+ 15% / - 25%); I <sub>n</sub> = 0,5A<br>(- 35% for 1min)   |     |     |     |     |  |      |      |  |
| Rated supply voltage fan V                       |   |     |     |     |     | 3-ph. AC 400 (± 15%);<br>0,24A, 95Watt<br>Air flow: 570m <sup>3</sup> /h<br>Fan noise: 63dBA |      |      |  |
| Rated supply voltage field V                     | 2-ph. AC 400 (+ 15% / - 20%)  |     |     |     |     |  |      |      |  |
| Rated frequency Hz                               | Converters automatically adapt themselves to the frequency of the available supply voltage in the range from 45 to 65 Hz (Armature and field are independent).  |     |     |     |     |  |      |      |  |
| Rated DC voltage V                               | 520   |     |     |     |     |  |      |      |  |
| Rated DC current A                               | 30  | 60  | 100 | 140 | 200 | 250  | 400  | 600  |  |
| Overload capability                              | max. 150% rated DC current  |     |     |     |     |  |      |      |  |
| Rated output kW                                  | 16  | 31  | 52  | 73  | 104 | 130  | 208  | 312  |  |
| Power loss at rated DC current (approx.) W       | 140   | 230 | 320 | 440 | 650 | 800  | 1250 | 1850 |  |
| Rated DC voltage field V                         | max. 325  |     |     |     |     |  |      |      |  |
| Rated DC current field A                         | 5   | 10  |     |     | 15  |  | 25   |      |  |
| Operational ambient temperature °C               | 0 to 45 at I <sub>rated</sub> self-ventilated <sup>3)</sup>   |     |     |     |     | 0 to 35 at I <sub>rated</sub> forced-cooled <sup>3)</sup>                                    |      |      |  |
| Storage and transport temperature °C             | - 30 to + 85  |     |     |     |     |  |      |      |  |
| Installation altitude above sea level            | ≤ 1000 m at rated DC current <sup>4)</sup>  |     |     |     |     |  |      |      |  |
| Control stability                                | Δn = 0.006% of the motor rated speed, is valid for pulse encoder operation <u>and</u> digital setpoint<br>■n = 0.1% of the rated motor speed, is valid for analog tachometer or analog setpoint <sup>2)</sup> |     |     |     |     |  |      |      |  |
| Humidity classification<br>DIN 40040<br>SN 26556 | F   |     |     |     |     |  |      |      |  |
| Deg. of prot. DIN 40050<br>IEC 144               | IP 00   |     |     |     |     |  |      |      |  |
| Dimensions                                       | refer to dimension drawings   |     |     |     |     |  |      |      |  |
| Weight (approx.) kg                              | 11  | 14  | 14  | 16  | 23  | 23   | 31   | 31   |  |

Explanation of the footnotes after the tables

## 640A to 1200A converters, 3-ph. AC 400V bis 750V / 1Q

| Order No.  | 6RA24...-4DS22  |      | 6RA24...-4GS22                                |      | 6RA24...-4KS22                                |      |
|--|---|------|---|------|---|------|
|  | 87  | 91   | 87  | 91   | 85  | 87   |
| Rated supply voltage armature V                  | 3-ph. AC 400 <sup>1)</sup><br>(+ 15% / - 20%)   |      | 3-ph. AC 500 <sup>1)</sup><br>(+ 10% / - 15%) |      | 3-ph. AC 750 <sup>1)</sup><br>(+ 10% / - 15%) |      |
| Rated supply voltage electronics power supply V  | 2-ph. AC 400 (+ 15% / - 25%); I <sub>n</sub> = 0,5A<br>(- 35% for 1min)   |      |   |      |   |      |
| Rated supply voltage fan V                       | 3-ph. AC 400 (± 15%); 2x0,27A, 2x120Watt<br>Air flow: 1310m <sup>3</sup> /h at 50Hz / 1425m <sup>3</sup> /h at 60Hz<br>Fan noise: 70dBA at 50Hz / 73dBA at 60Hz   |      |   |      |   |      |
| Rated supply voltage field V                     | 2-ph. AC 400 (+ 15% / - 20%)  |      |   |      |   |      |
| Rated frequency Hz                               | Converters automatically adapt themselves to the frequency of the available supply voltage in the range from 45 to 65 Hz (Armature and field are independent).  |      |   |      |   |      |
| Rated DC voltage V                               | 485   |      | 600   |      | 900   |      |
| Rated DC current A                               | 850   | 1200 | 850   | 1200 | 640   | 860  |
| Overload capability                              | max. 150% rated DC current  |      |   |      |   |      |
| Rated output kW                                  | 412   | 582  | 510   | 720  | 576   | 774  |
| Power loss at rated DC current (approx.) W       | 3300  | 4900 | 3400  | 5000 | 4000  | 4800 |
| Rated DC voltage field V                         | max. 325  |      |   |      |   |      |
| Rated DC current field A                         | 30  |      |   |      |   |      |
| Operational ambient temperature °C               | 0 to 35 at I <sub>rated</sub><br>forced-cooled <sup>3)</sup>  |      |   |      |   |      |
| Storage and transport temperature °C             | - 30 to + 85  |      |   |      |   |      |
| Installation altitude above sea level            | ≤ 1000 m at rated DC current <sup>4)</sup>  |      |   |      |   |      |
| Control stability                                | Δn = 0.006% of the motor rated speed,<br>is valid for pulse encoder operation <u>and</u> digital setpoint<br>■n = 0.1% of the rated motor speed,<br>is valid for analog tachometer or analog setpoint <sup>2)</sup> |      |   |      |   |      |
| Humidity classification<br>DIN 40040<br>SN 26556 | F   |      |   |      |   |      |
| Deg. of prot.<br>DIN 40050<br>IEC 144            | IP 00   |      |   |      |   |      |
| Dimensions                                       | refer to dimension drawings   |      |   |      |   |      |
| Weight (approx.) kg                              | 77  |      |   |      |   |      |

Explanation of the footnotes after the tables

## 640A to 1200A converters, 3-ph. AC 400V bis 750V / 4Q

| Order No.  | 6RA24...-4DV62  |      | 6RA24...-4GV62                                |      | 6RA24...-4KV62                                |      |
|--|---|------|---|------|---|------|
|  | 87  | 91   | 87  | 91   | 85  | 87   |
| Rated supply voltage armature V                  | 3-ph. AC 400 <sup>1)</sup><br>(+ 15% / - 20%)   |      | 3-ph. AC 500 <sup>1)</sup><br>(+ 10% / - 15%) |      | 3-ph. AC 750 <sup>1)</sup><br>(+ 10% / - 15%) |      |
| Rated supply voltage electronics power supply V  | 2-ph. AC 400 (+ 15% / - 25%); I <sub>n</sub> = 0,5A<br>(- 35% for 1min)   |      |   |      |   |      |
| Rated supply voltage fan V                       | 3-ph. AC 400 (± 15%); 2x0,27A, 2x120Watt<br>Air flow: 1310m <sup>3</sup> /h at 50Hz / 1425m <sup>3</sup> /h at 60Hz<br>Fan noise: 70dBA at 50Hz / 73dBA at 60Hz   |      |   |      |   |      |
| Rated supply voltage field V                     | 2-ph. AC 400 (+ 15% / - 20%)  |      |   |      |   |      |
| Rated frequency Hz                               | Converters automatically adapt themselves to the frequency of the available supply voltage in the range from 45 to 65 Hz (Armature and field are independent).  |      |   |      |   |      |
| Rated DC voltage V                               | 420   |      | 520   |      | 790   |      |
| Rated DC current A                               | 850   | 1200 | 850   | 1200 | 640   | 860  |
| Overload capability                              | max. 150% rated DC current  |      |   |      |   |      |
| Rated output kW                                  | 357   | 504  | 442   | 624  | 505   | 679  |
| Power loss at rated DC current (approx.) W       | 3300  | 4900 | 3400  | 5000 | 4000  | 4800 |
| Rated DC voltage field V                         | max. 325  |      |   |      |   |      |
| Rated DC current field A                         | 30  |      |   |      |   |      |
| Operational ambient temperature °C               | 0 to 35 at I <sub>rated</sub><br>forced-cooled <sup>3)</sup>  |      |   |      |   |      |
| Storage and transport temperature °C             | - 30 to + 85  |      |   |      |   |      |
| Installation altitude above sea level            | ≤ 1000 m at rated DC current <sup>4)</sup>  |      |   |      |   |      |
| Control stability                                | Δn = 0.006% of the motor rated speed,<br>is valid for pulse encoder operation <u>and</u> digital setpoint<br>■n = 0.1% of the rated motor speed,<br>is valid for analog tachometer or analog setpoint <sup>2)</sup> |      |   |      |   |      |
| Humidity classification<br>DIN 40040<br>SN 26556 | F   |      |   |      |   |      |
| Deg. of prot.<br>DIN 40050<br>IEC 144            | IP 00   |      |   |      |   |      |
| Dimensions                                       | refer to dimension drawings   |      |   |      |   |      |
| Weight (approx.) kg                              | 77  |      |   |      |   |      |

Explanation of the footnotes after the tables



1) For a rated supply voltage below 360V (475V for 500V converters), the rated DC voltage for 1Q converters of 485 V (600 V) or for 4Q converters of 420 V (520 V) can no longer be reached.

2) Conditions:

The closed-loop control stability is referred to the rated drive speed and when the SIMOREG K converter is in the warm condition. The following prerequisites are used as basis:

- Temperature changes of  $\pm 10$  °K
- Supply voltage changes from + 10% / - 5% of the rated voltage
- Load changes up to 100% of the maximum torque
- Temperature coefficient of the temperature-compensated tachogenerator, 0.15‰ per 10 °K (only for an analog tachometer)
- Constant setpoint

3) Loading as a function of the cooling medium temperature (refer to P077, Section 9.2)

| Ambient temp.<br>or cooling<br>medium temp. | Changing the load values (percentage reduction "a") |  |   |
|---|---|--|---|
|   | for converters with<br>self-cooling                 | for converters $\leq 600$ A<br>with enhanced air cooling | for converters $> 600$ A<br>with enhanced air cooling |
| + 35 °C                                     |   | 0 %  | 0 %   |
| + 40 °C                                     |   | - 6 %  | - 5 %   |
| + 45 °C                                     | 0 %   | - 12 %   | - 10 %  |
| + 50 °C <sup>a)</sup>                       | - 6 %   | (- 17 %) <sup>1)</sup>                                   | - 15 %  |
| + 55 °C                                     | - 11 %  |  |   |
| + 60 °C                                     | - 18 %  |  |   |

1) When operating converters  $\leq 600$  A with forced cooling, in spite of derating, at an ambient or cooling medium temperature of 50°C, this is only possible if the rated supply voltage of the converter fan is in the restricted tolerance range of 400 V + 10% -15%.

4) Load as a function of the installation altitude (refer to P077, Section 9.2)

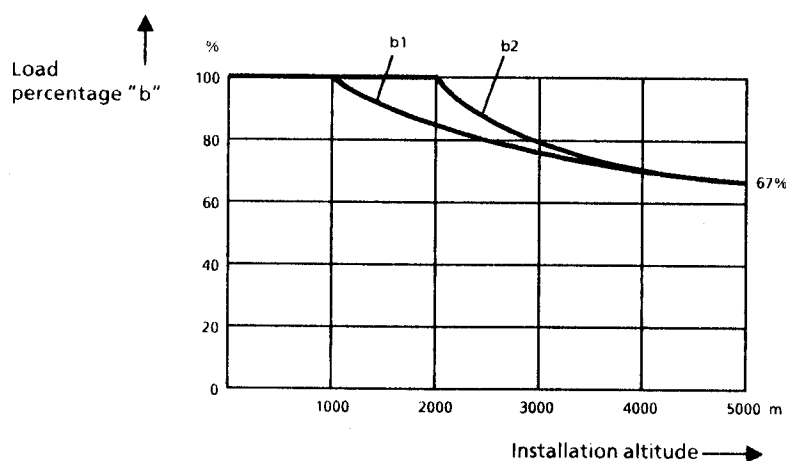

Curve b1: Reduction factor for the load values specified on the rating plate for installation altitudes above 1000m

Curve b2: Reduction factor for the armature rated supply voltage for installation altitudes above 2000m

### 3.5 Applicable standards

VDE 0106, Part 100

Arrangement of operator control elements in the vicinity of components/parts at hazardous voltage levels.

VDE 0110, Part 1

Insulation coordination for electrical equipment in low-voltage installations.

Requirement for reliable isolation ⇒ degree of pollution 2 for boards and power section.

Only non-conductive pollution occurs. Occasional conductivity due to moisture condensation must be however expected.

“Moisture condensation is excluded, as the components are only permitted for humidity classification F.”

VDE 0113 A2

Electrical equipment on industrial machines.

VDE 0160, Paragraphs 5.3.1.1.2 and 5.3.1.1.3

Regulations for equipping electrical power systems with electronic equipment.

VDE0298

Use of cables and insulated cables for electrical power systems.

DIN IEC 38

Supply voltage tolerance.

VDE 0843 Part 2, Part 3, Part 4 and IEC 801-2, 801-3, 801-4

Noise immunity

DIN IEC 68-2-6, severity grade 12 (SN29010 Part1)

Mechanical stressing

### 3.6 Abbreviations

|      |   |
|------|---|
| PT   | Configurable technology board             |
| CS51 | Communication system                      |
| S    | Interface board (= CS51)                  |
| SST1 | Serial interface 1 on the interface board |
| SST2 | Serial interface 2 on the interface board |
| PKW  | Parameter ID value                        |
| PZD  | Process data                              |
| SOW  | Setpoint                                  |
| ISW  | Actual value                              |
| STW  | Control word                              |
| STWF | Freely-definable control word             |
| ZSW  | Converter status word                     |
| ZSW1 | Converter-specific status word 1          |
| ZSW2 | Converter-specific status word 2          |

## 4. Transport, unpacking

SIMOREG converters are packed in the manufacturing plant as specified when ordered. A product packing label is provided on the box.



Avoid jolts and shocks during transport, e.g. when setting down.

Observe the instructions on the packing for transport, storage and correct handling.

The SIMOREG converter can be installed after it has been unpacked and checked to make sure that the scope of supply is complete and that the unit was not damaged.

The packing consists of cardboard and corrugated paper and can be disposed of corresponding to the local regulations for disposal of board products.

### 4.1 Damage during transport

|  |  |
|--|--|
| <br> | <p><b>WARNING</b></p> <hr/> <p>If a SIMOREG converter was damaged during transport, it is not permissible that it is connected up without first being subject to a high-voltage test.</p> <p>If this is not observed, it can lead to death, severe bodily injury or significant material damage.</p> |
|--|--|

Please observe the following points if the unit was damaged during transport:

#### 4.1.1 Procedure for transport damage

Carefully examine the equipment before you accept the shipment from the transport company. If you do not notify the appropriate authorities immediately if the converter was damaged, under certain circumstances you can lose your right to claim.

If required, you can request support from the local Siemens office.

- When received, examine the shipment to ensure that it is complete and not damaged.
- Damaged/ missing items which are obviously visible, should be specified in the shipping papers and must be countersigned by personnel from the transport company.
- Immediately
  - notify the transport company in writing, or
  - notify, in writing, other transport companies involved or
  - notify, in writing the mail service or
  - notify, in writing the appropriate railway personnel
 and schedule a meeting so that they can ascertain the transport damage.

When notifying in writing make a note of the scope of the damage and estimated costs.

- Notification times for damage which is not immediately visible (including the time for mail):
  - 1 day: Mail (24 hours after the mail was delivered)
  - 6 days: Transport company
  - 7 days: Railway or long-haul/short-haul by truck
- The company who shipped the equipment should be notified either by telephone or by fax/telex.
- The police must be notified of
  - Theft
  - Fire damage
  - Accident damageReference number / police report / legal paperwork to the company who originally shipped the equipment.
- Keep the damaged equipment and packing until
  - Released by the shipping company
  - Possible inspection by the appropriate authorities
  - Possible damage evaluation by the shipping company, railway or mail service
- Send all documentation (shipping papers, transport insurance papers, communications with shipping companies, damage report from the appropriate authorities) to the party who shipped the equipment so that they can process the necessary paperwork for insurance purposes etc.
- The receiver should evaluate the situation for damage minimization/limiting (safe storage, examination for damage due to moisture e tc.

#### 4.1.2 Transport insurance

SIMOREG converters are insured, ex-factory. The following are not insured:

- Moving
- Transport within the customers premises (transport within a factory without using public roads)

## 5. Installation

 **CAUTION**

Bodily injury or material damage can result if the equipment is carelessly lifted.

The converter should only be lifted using suitable equipment and under the instructions of appropriately qualified personnel.

 The user is responsible for installing the converter, motor, transformer as well as other equipment according to the safety regulations (e.g. DIN, VDE), as well as all other relevant national or local regulations regarding cable dimensioning and protection, grounding, isolating switch, overcurrent protection etc.

The converter must be installed in accordance with the relevant safety regulations (e.g. DIN, VDE), as well as all other relevant national and local regulations. It must be ensured that the grounding, cable dimensioning and appropriate short-circuit protection have been implemented to guarantee operational safety and reliability.

- **Converter with 15A rated current**

These can either be mounted flat on a mounting surface in the cubicle or machine rack, on edge, or inserted in withdrawable racks (refer to dimension drawings, Section 5.1).

- **Converter with 30A to 600A rated current**

These are mounted vertically in cubicles or machine racks with the power connections towards the bottom (refer to dimension drawings, Section 5.1).

- Converter with 640A to 1200A rated current

### Cubicle mounting

The cubicle mounting sets for 6QG35 can be used for mounting SIMOREG converters in 8MF system cubicles.

The profile rails and boards are bolted at the required height to the perforated strips of the 600 mm-wide system cubicles. The SIMOREG converter is then positioned so that the angled pieces of the side panels are flush with the profile rail, and it can be inserted into the cubicle. The SIMOREG is then bolted into place using 4 M6 bolts.

#### Single-tier design

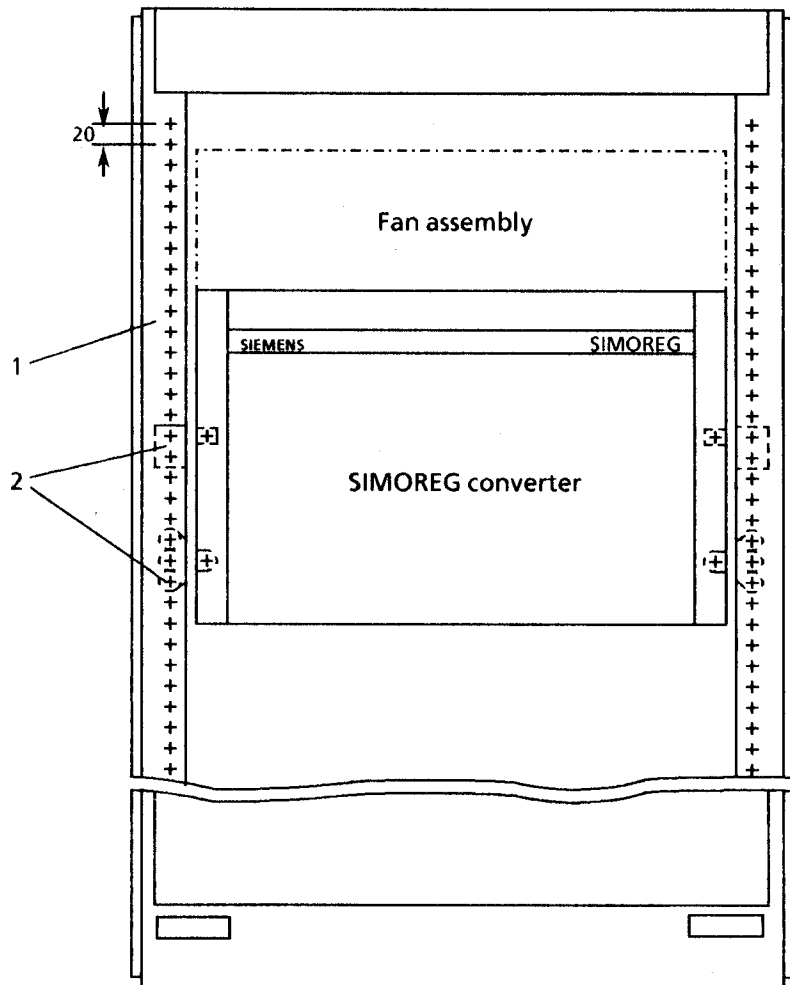

- 1 Cubicle frame (20mm hole spacing)
- 2 Cubicle mounting set (profile rail and panel)
  - for 600mm cubicle depth 6QX5304
  - for 800mm cubicle depth 6QX5305

When connecting a SIMOREG converter in parallel with a SITOR set, the output must be reduced to 85% (refer to P077 in Section 9.2).

For this arrangement, the SIMOREG converter must be ordered without fan assembly (i.e. MLFB, 3rd block with Z and code M80). The SITOR set must be ordered complete (with fan assembly and incorporated fan monitoring). The SIMOREG converter fan monitoring should be suppressed per software (refer to parameter P850, Section 8.2.4). The SITOR set, mounted on the SIMOREG converter should be additionally mounted to the panel using two angle brackets (Order No. 6QX5061). A 1m-long ribbon cable, Order No.

6RY1247-0AA14 is required to control the SITOR set.

With this arrangement, power can only be connected at the rear of the units.

Mounting the converter with cubicle mounting sets as for a single-tier design. Only one mounting set is required. SIMOREG converter and SITOR set must be bolted before mounting.

Two-tier design

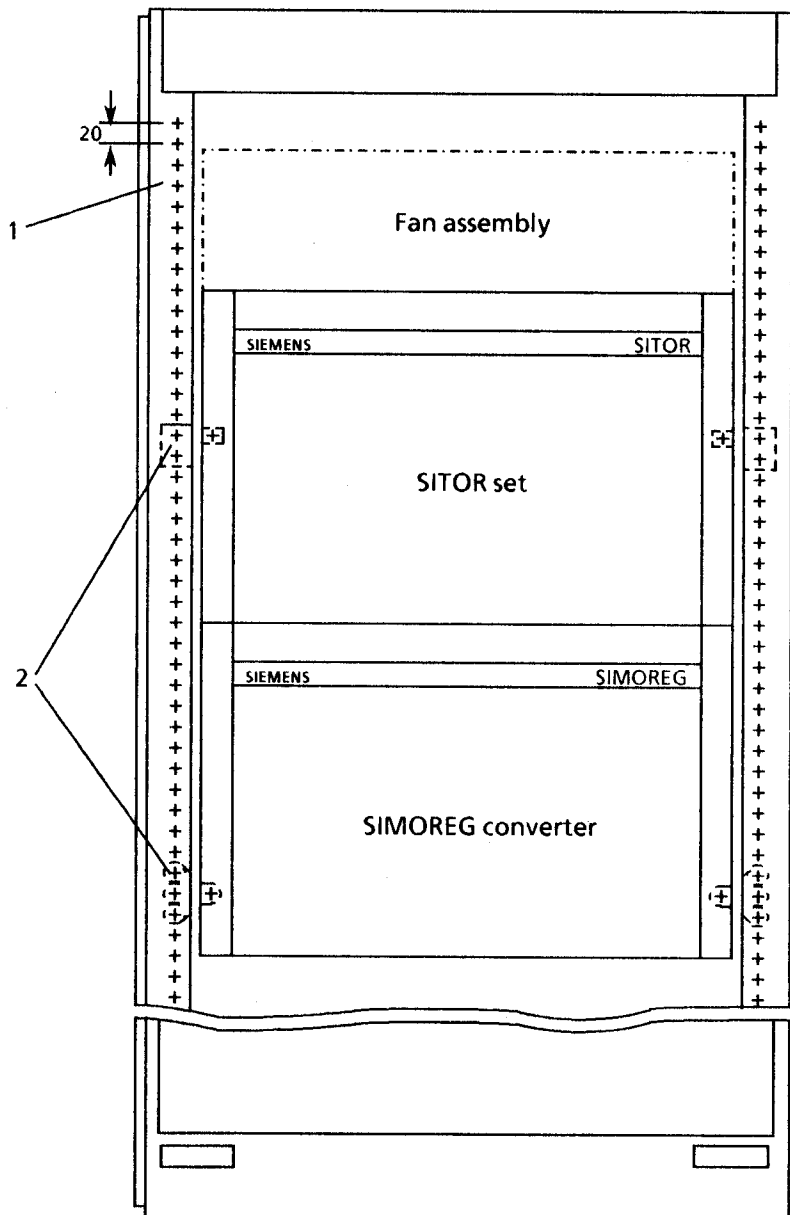

- 1 Cubicle frame (20mm hole spacing)
- 2 Cubicle mounting set (profile rail and panel)
  - for 600mm cubicle depth 6QX5304
  - for 800mm cubicle depth 6QX5305

## Wall mounting

For wall mounting, the SIMOREG converter is mounted at the left and right on brackets and retained using 4 bolts.

### Single-tier design

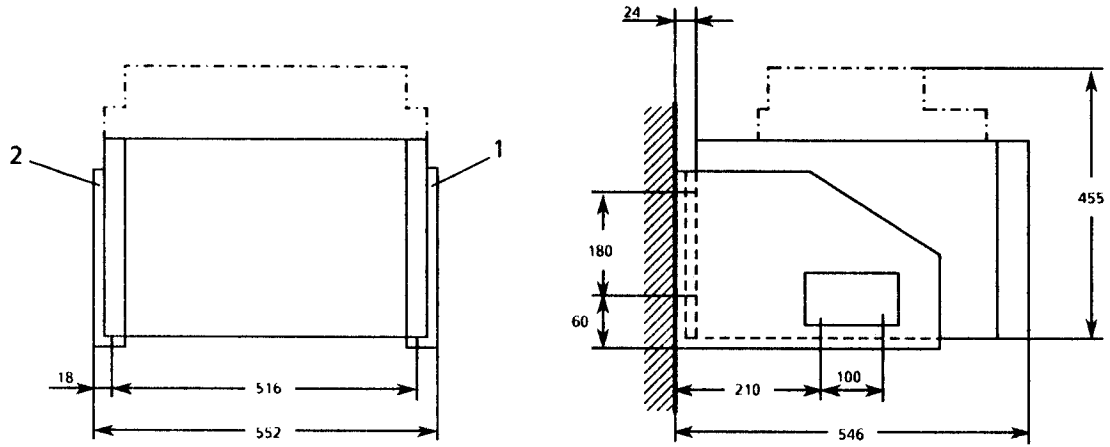

- |   |                   |         |
|---|-------------------|---------|
| 1 | Righthand bracket | 6QX5347 |
| 2 | Lefthand bracket  | 6QX5348 |



Two arrangements are possible when a SIMOREG converter is connected in parallel (rated armature DC current ( $> 600$  A), using one SITOR set:

- Side-by-side arrangement  
A 2m-long ribbon cable, Order No. 6DD1684-0BH1 is required to control the SITOR set.
- One above the other (de-rating to 85%, refer to P077, in Section 9.2)  
For this arrangement, the SIMOREG converter must be ordered without fan assembly (i.e. MLFB, 3rd block with Z and code M80). The SITOR set must be ordered complete (with fan assembly and incorporated fan monitoring). The SIMOREG converter fan monitoring should be suppressed per software (refer to parameter P850, Section 8.2.4). The SITOR set, mounted on the SIMOREG converter should be additionally mounted to the panel using two angle brackets (Order No. 6QX5061). A 1m-long ribbon cable, Order No. 6RY1247-0AA14 is required to control the SITOR set.  
With this arrangement, power can only be connected at the rear of the units.

### Two-tier design

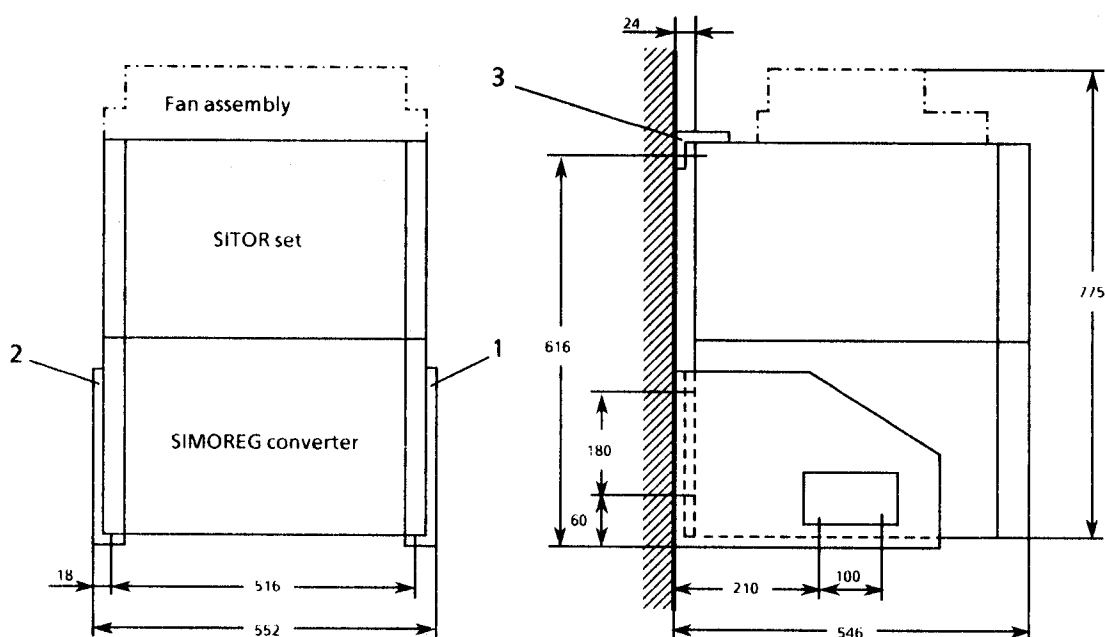

- |   |                   |         |
|---|-------------------|---------|
| 1 | Righthand bracket | 6QX5347 |
| 2 | Lefthand bracket  | 6QX5348 |
| 3 | Angle             | 6QX5061 |

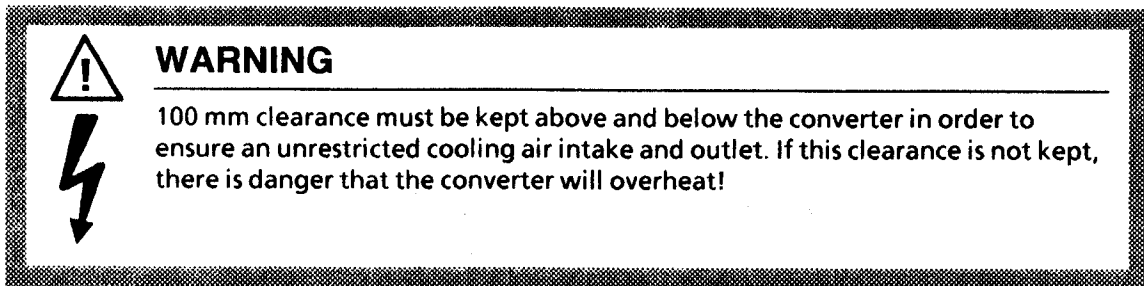

## 5.1 Dimension drawings

### Converter type D.../15

Flat mounting:

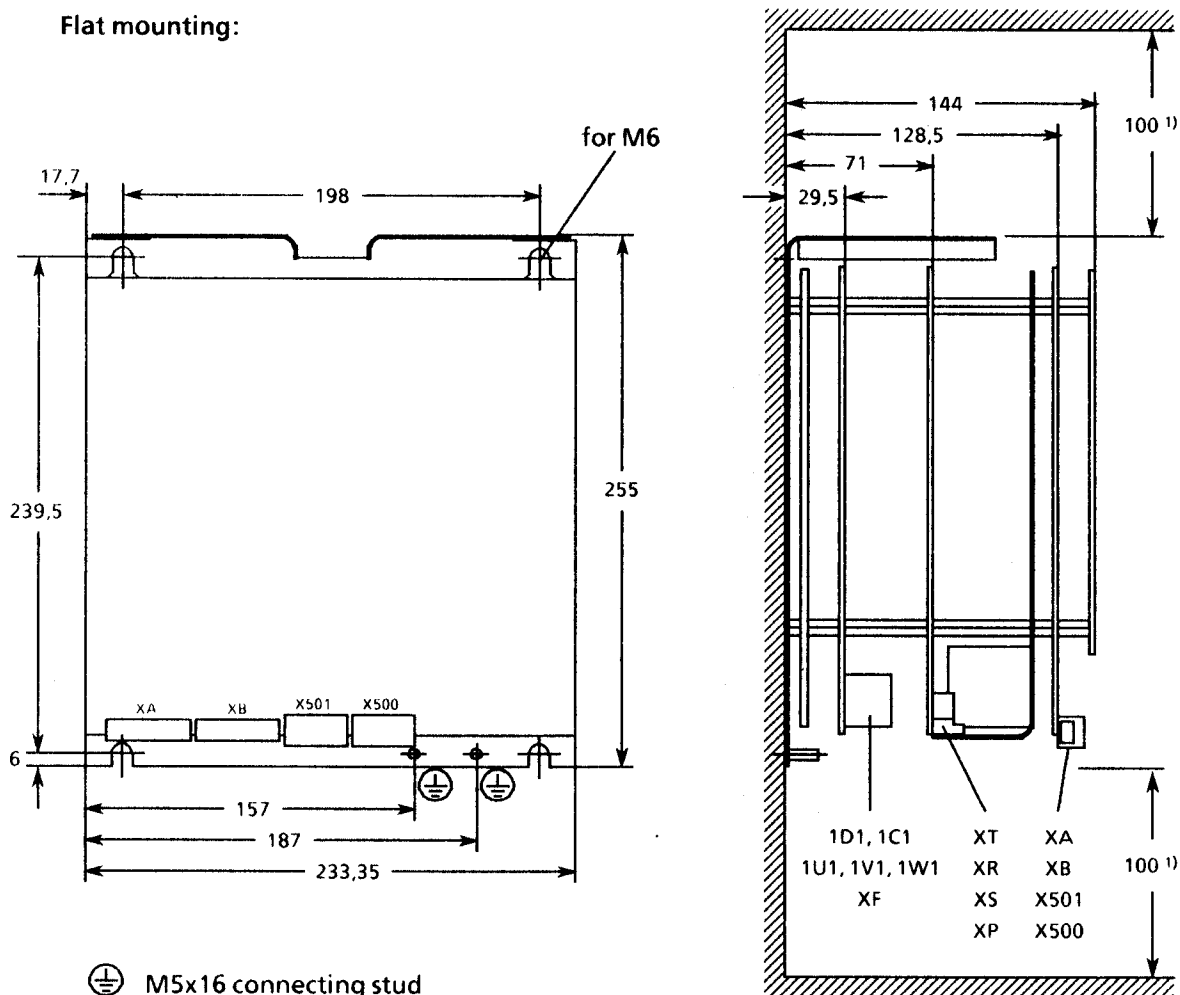

- 1) Minimum clearance for air circulation.  
It should be ensured that there is sufficient cooling air intake!

**Mounting the converter on its end:**

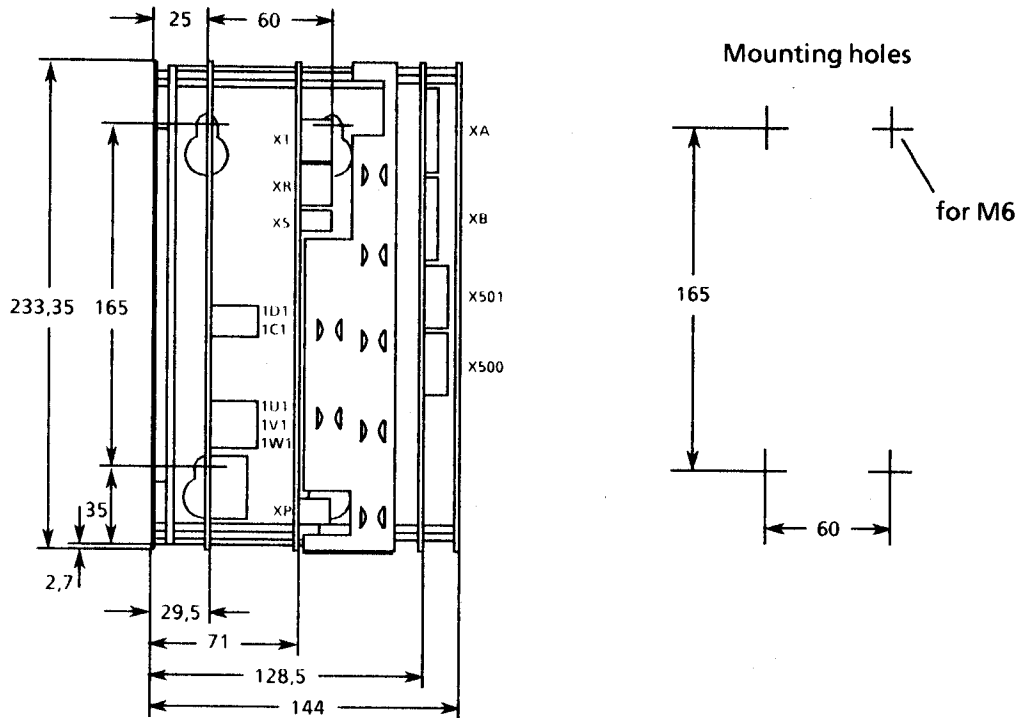

**Mounting the converter in the ES 902 C packaging system:**

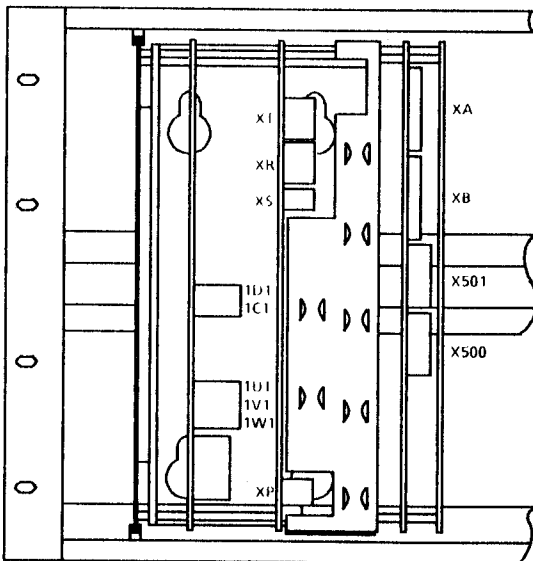

- Space required in the subrack: 22 grid divisions = 111,76mm
- without supplementary boards
  - with the minimum clearance between two converters

### Converter type D.../30 - 60

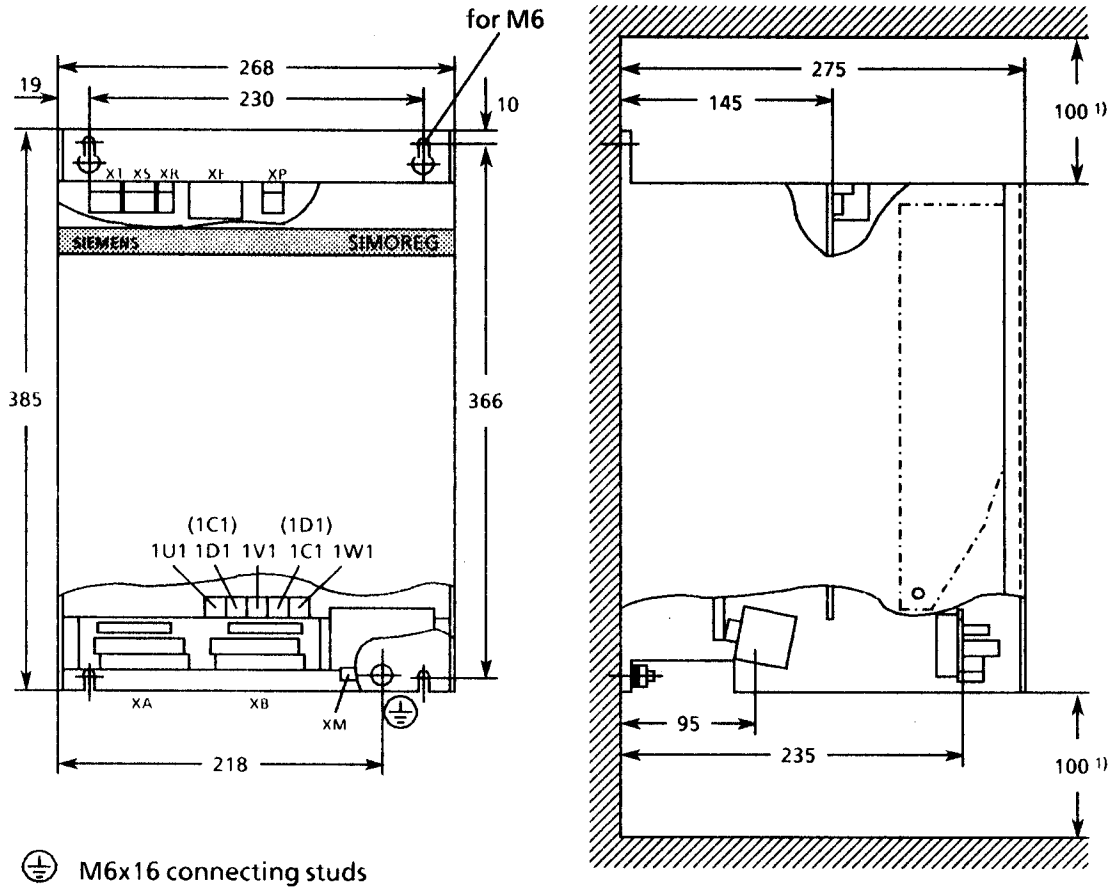

Power connecting terminals for 30A converters: 10mm<sup>2</sup>  
60A converters: 35mm<sup>2</sup>

- 1) Minimum clearance for air circulation.  
It should be ensured that there is sufficient cooling air intake!

### Converter type D... / 90 - 140

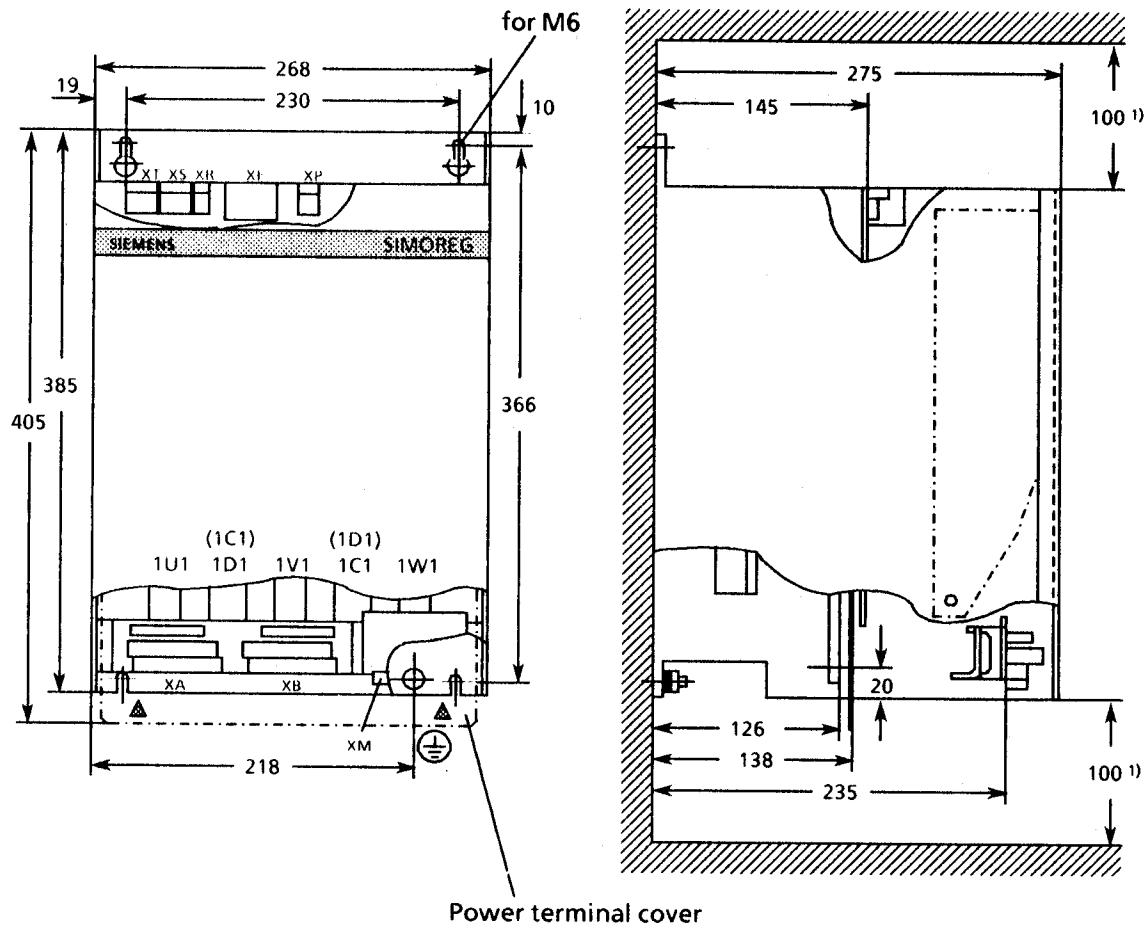

- 1) Minimum clearance for air circulation  
It should be ensured that there is sufficient cooling air intake!

Converter type D... / 200 - 250

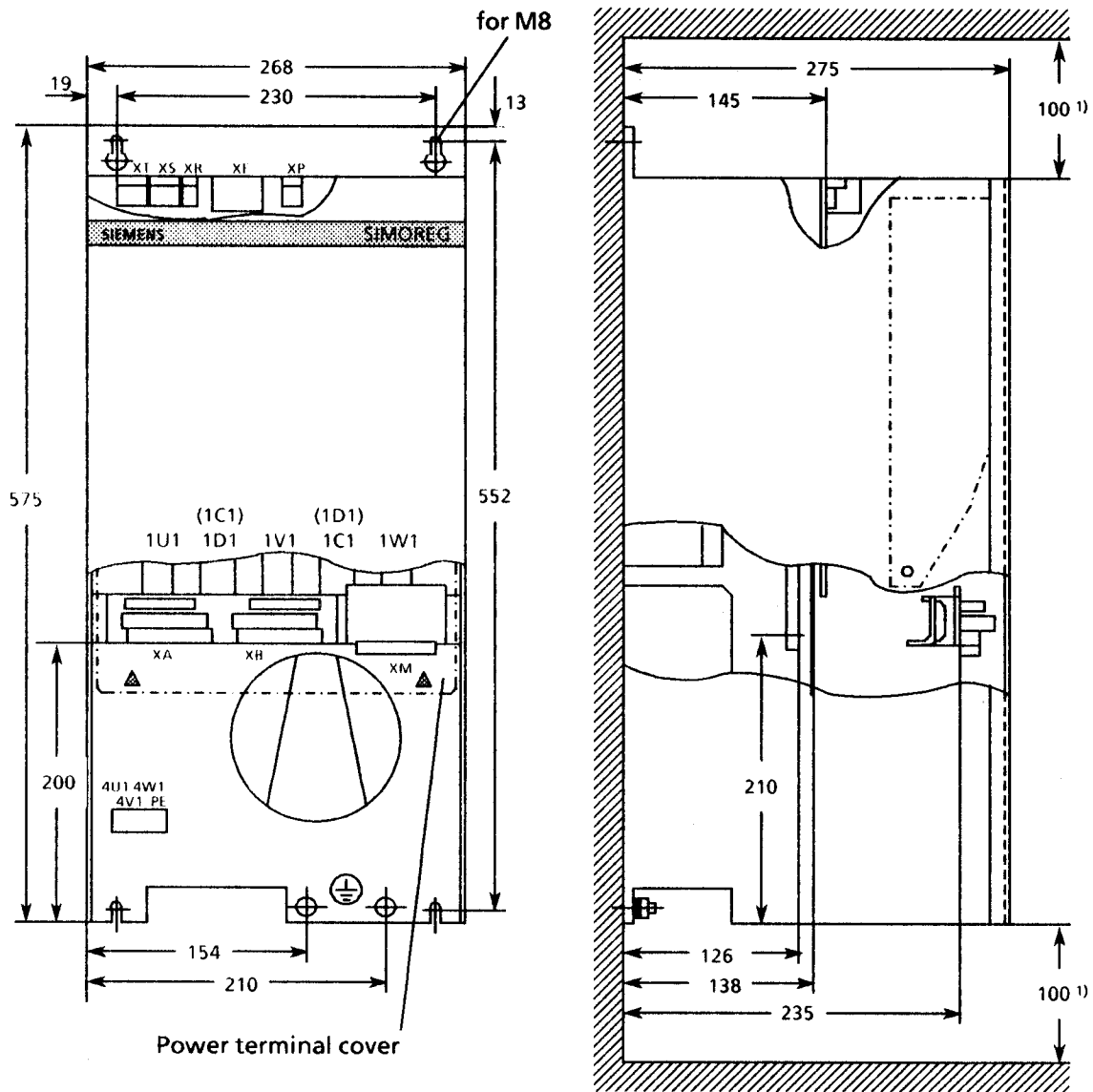

⊕ M8x20 connecting studs

Power connection 1U1, 1D1, 1V1, 1C1, 1W1: M10

- 1) Minimum clearance for air circulation  
It should be ensured that there is sufficient cooling air intake!

Converter type D... / 400 - 600

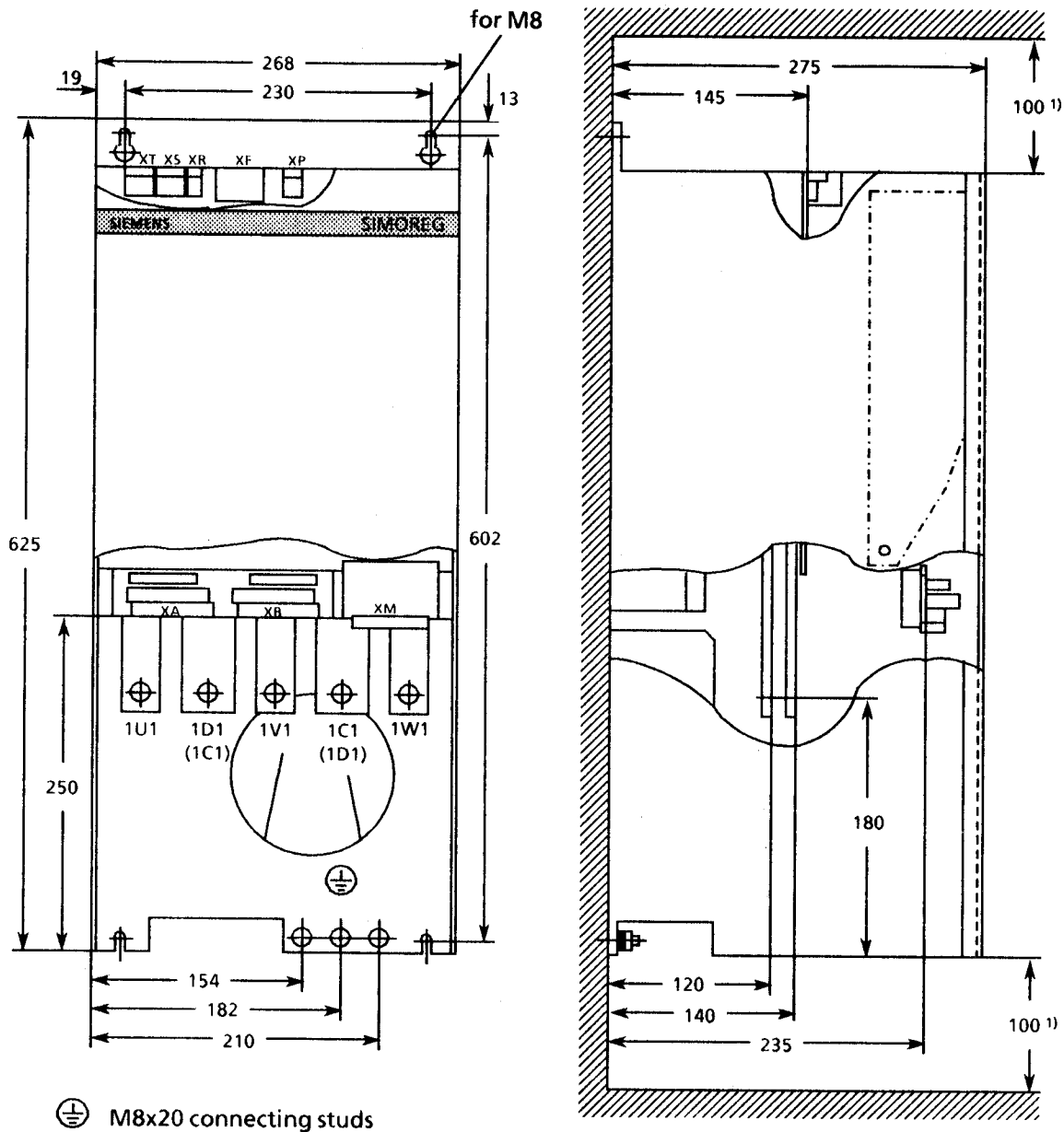

Power connection 1U1, 1D1, 1V1, 1C1, 1W1: M10

- 1) Minimum clearance for air circulation  
It should be ensured that there is sufficient cooling air intake!

Converter type D ... / 640 - 1200

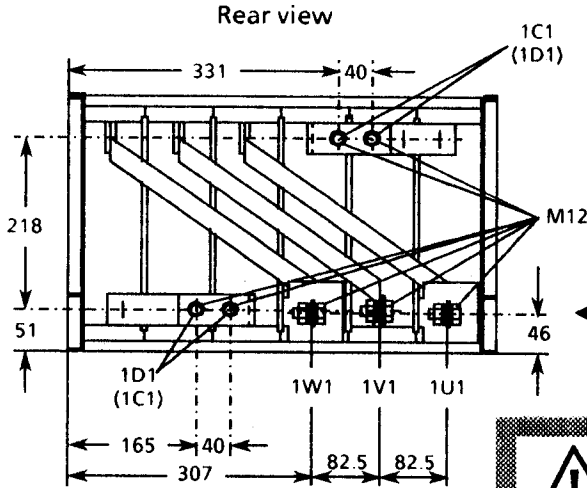
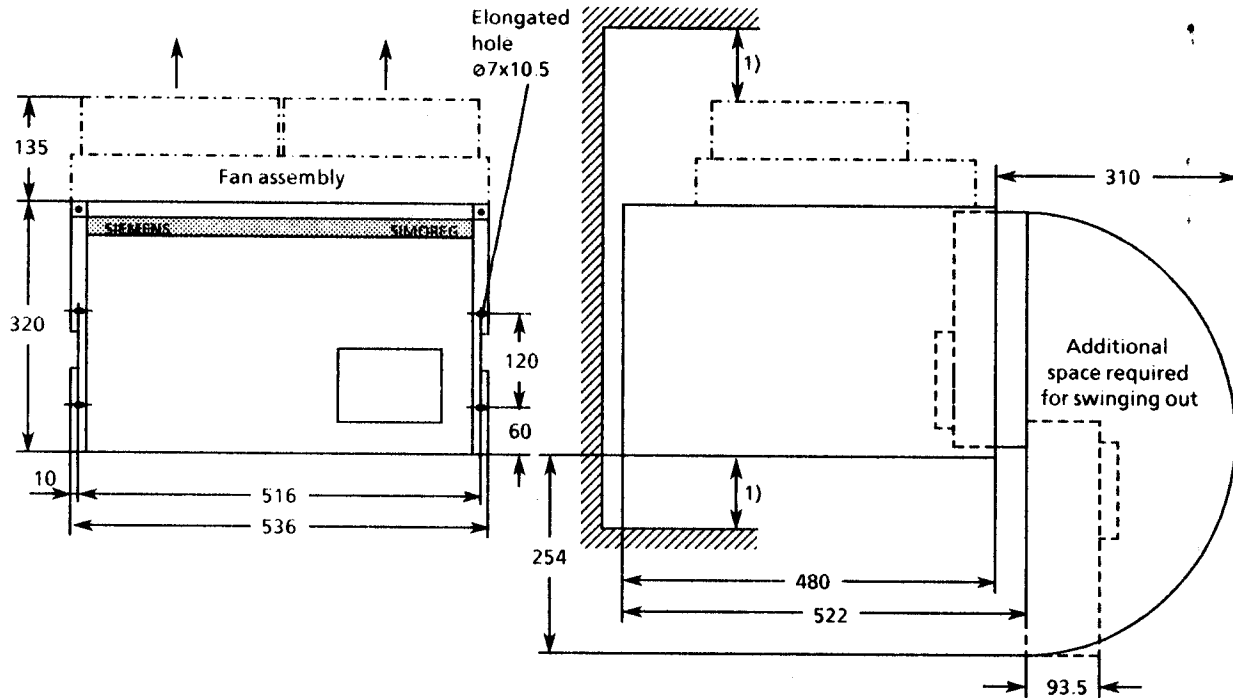

1) Minimum clearance for air circulation. It should be ensured that there is sufficient cooling air intake!

**⚠ WARNING**

The power connection for 1U1, 1V1, 1W1 must be made at the lower end of the bus bars (i.e. lower right, when viewing the rear of the converter).

**⚡** The actual value current sensing function is not possible when incorrectly connected (current limiting and current control not effective, overcurrent danger!).



## 5.2 Position of PC boards, ribbon cables and terminal strips for 15A converters (basic converters)

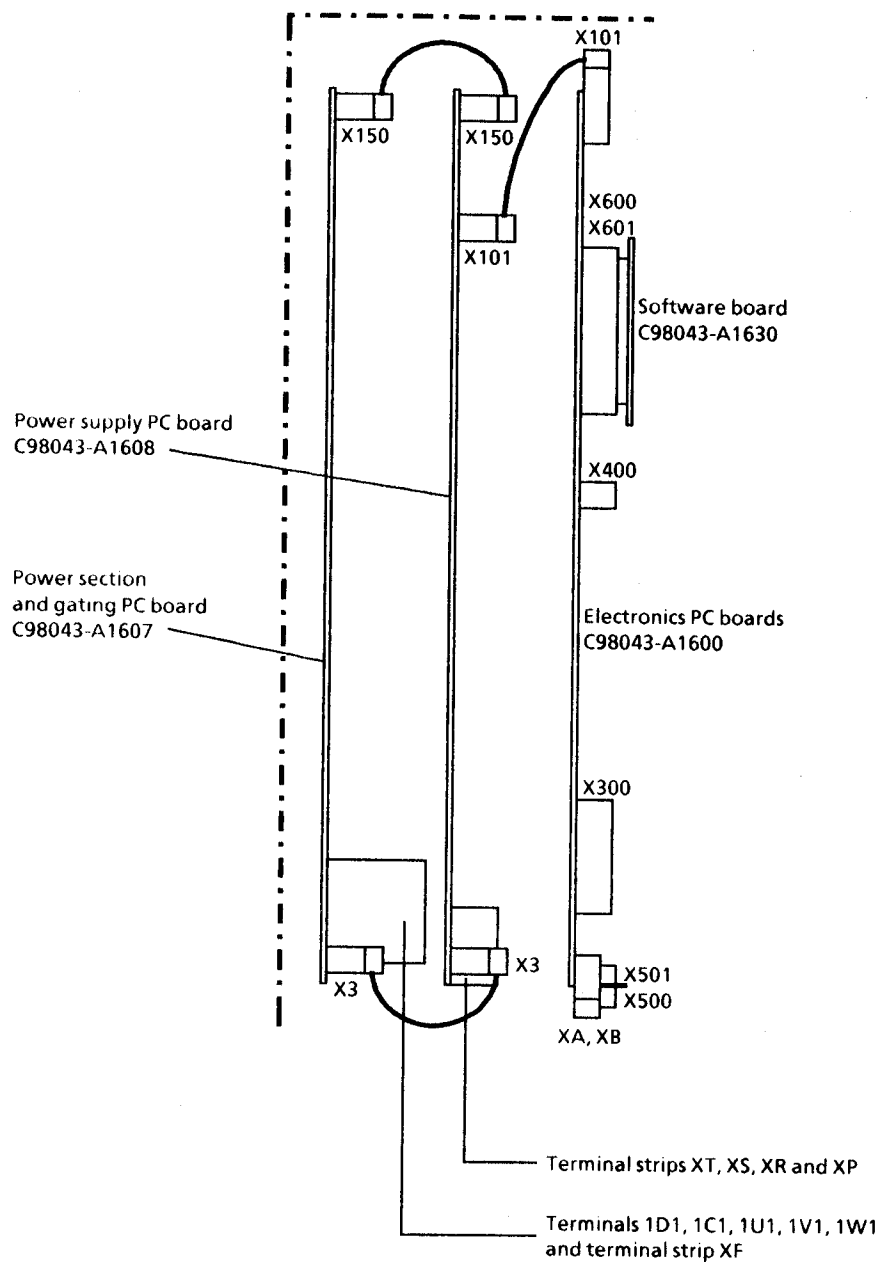

for 30A - 600A converters (basic converters)

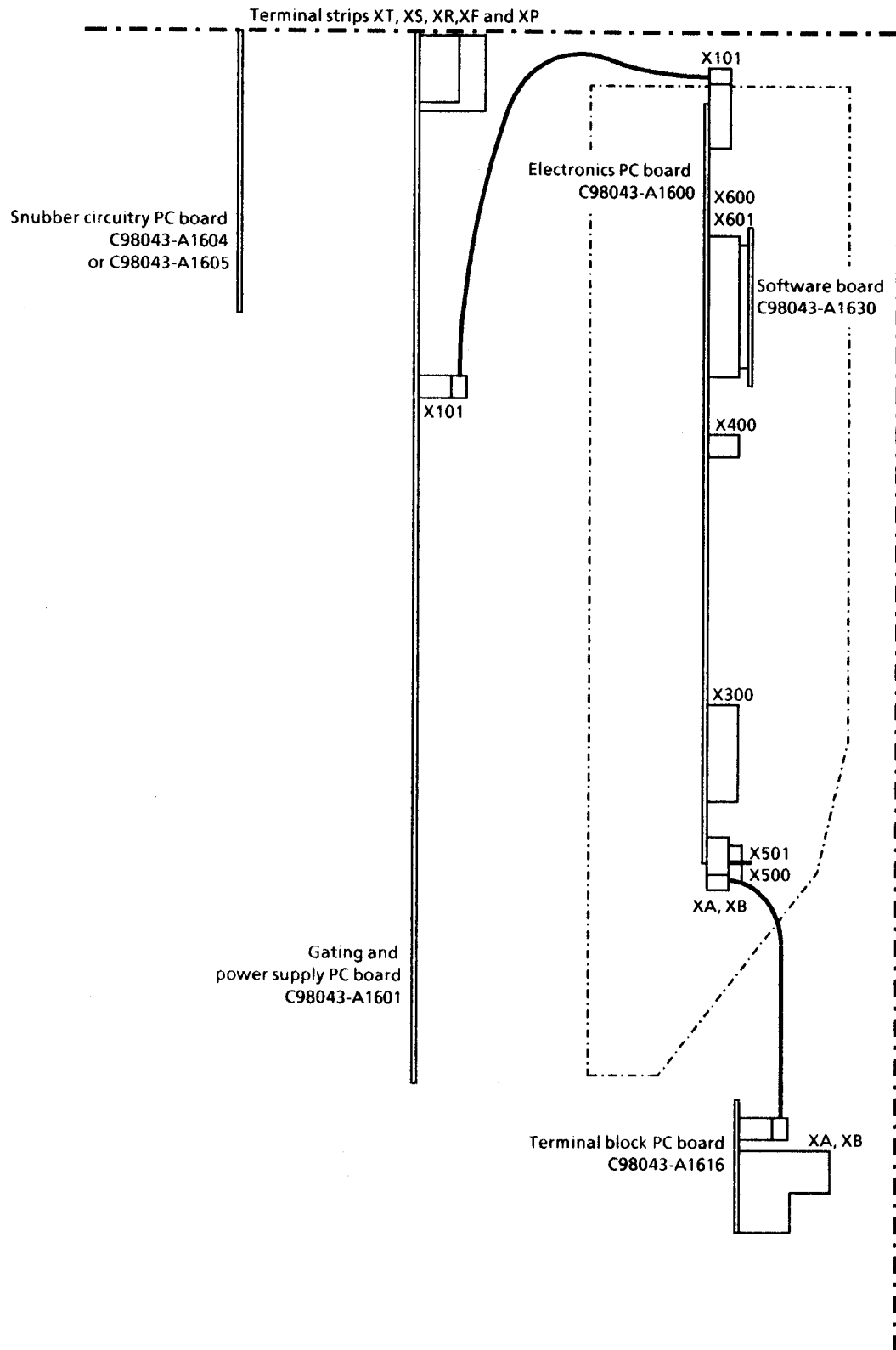

for converters > 600A (basic converters)

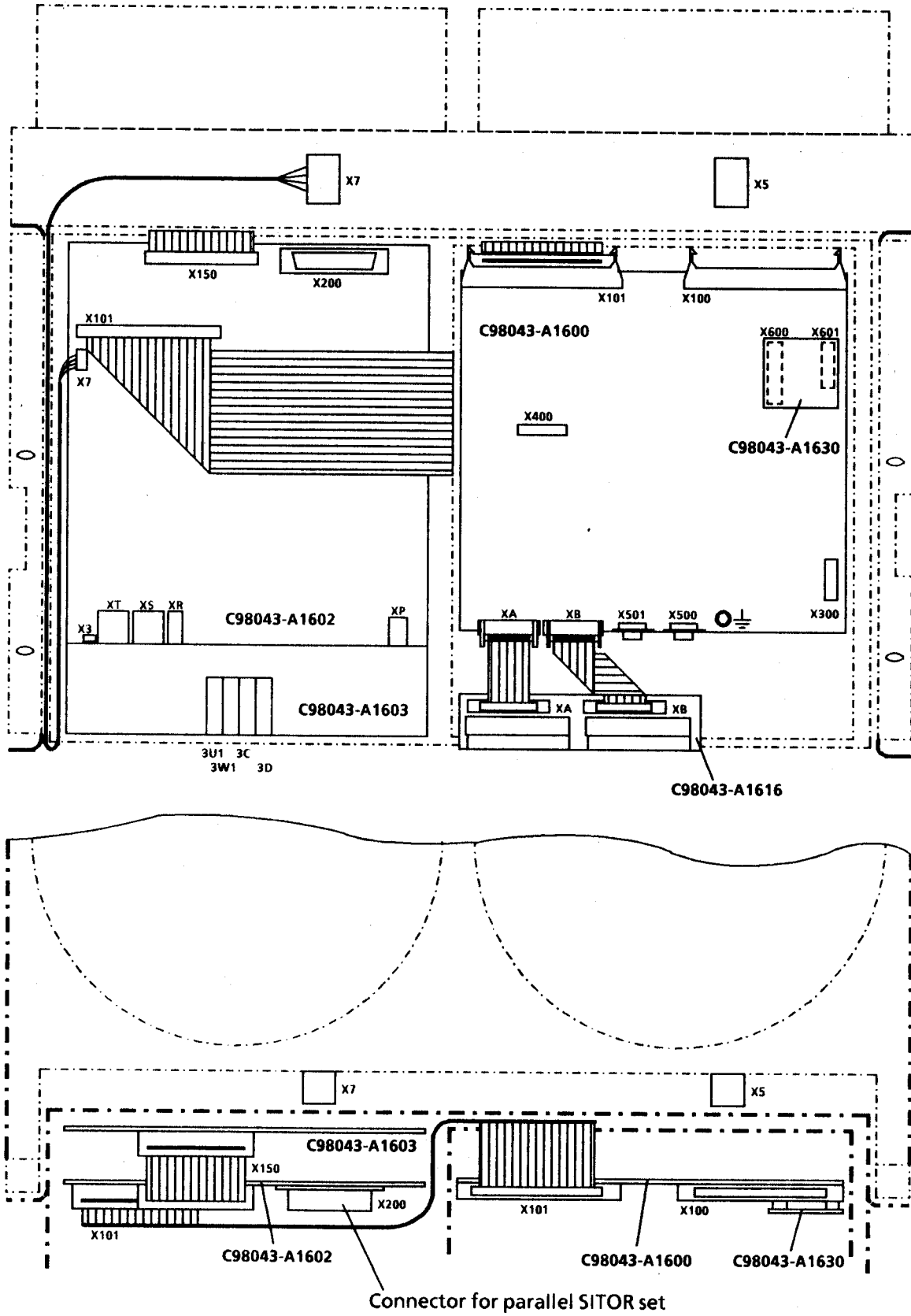

### 5.3 Installing the software board and options

 **Caution**  
The software board and the options can only be inserted when the converter is in a no-voltage condition.

#### 5.3.1 Software board

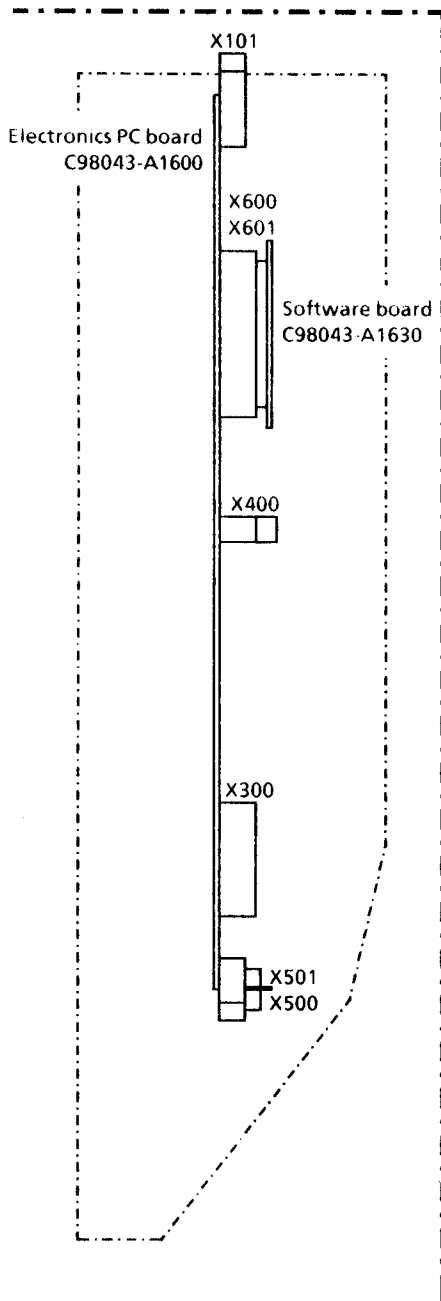

The C98043-A1630 software board is inserted on the C98043-A1600 electronics PC board (X600 and X601), and can be simply replaced.

### 5.3.2 Converter operator control panel (Order No.: 6RX1240-0AP20)

Only the cable supplied with the option must be used. The required mounting cut-out mounting is  $95.5 \pm 0.1\text{mm} \times 130.5 \pm 0.1\text{mm}$ , the required material thickness, 1.5 to 2mm.

The converter operator control panel can be snapped into the converter door cut-out after removing the cover.

The electrical connection with the converter is established using the ribbon cable supplied, between connector X1 (converter operator control panel) and connector X300 (PC board electronics).

The converter operator control panel can also be mounted outside the converter. A screened 2 m-long cable is available.

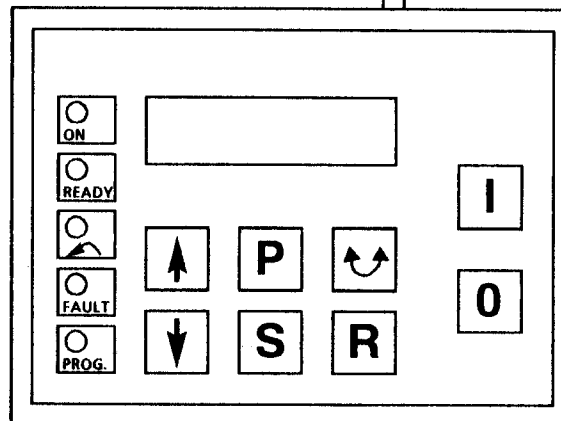
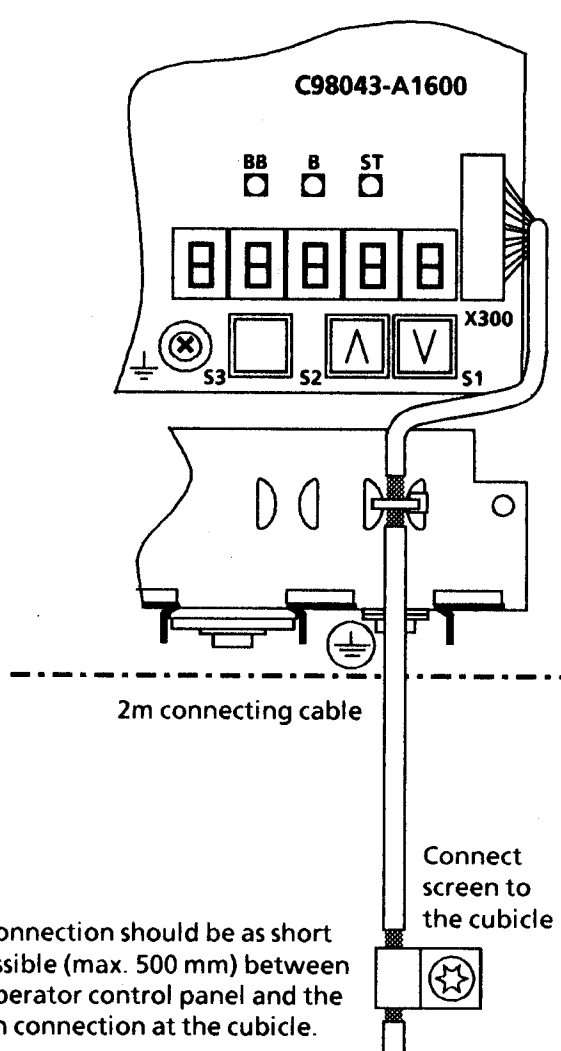
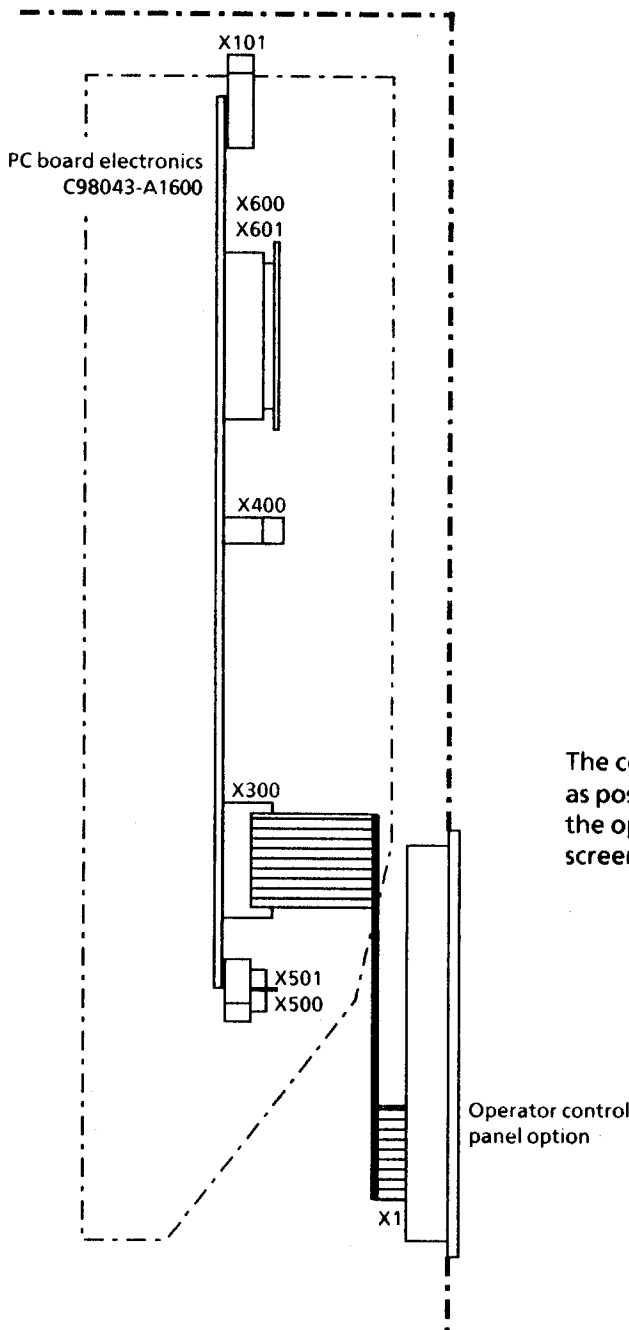

5.3.3 CS51 (Order No.: 6DD1660-0AH1)  
 PT10 (Order No.: 6DD3440-0AB3)

from SW1.20

from SW1.20

### 5.3.3.1 Installing supplementary boards for 30A to 1200A converters

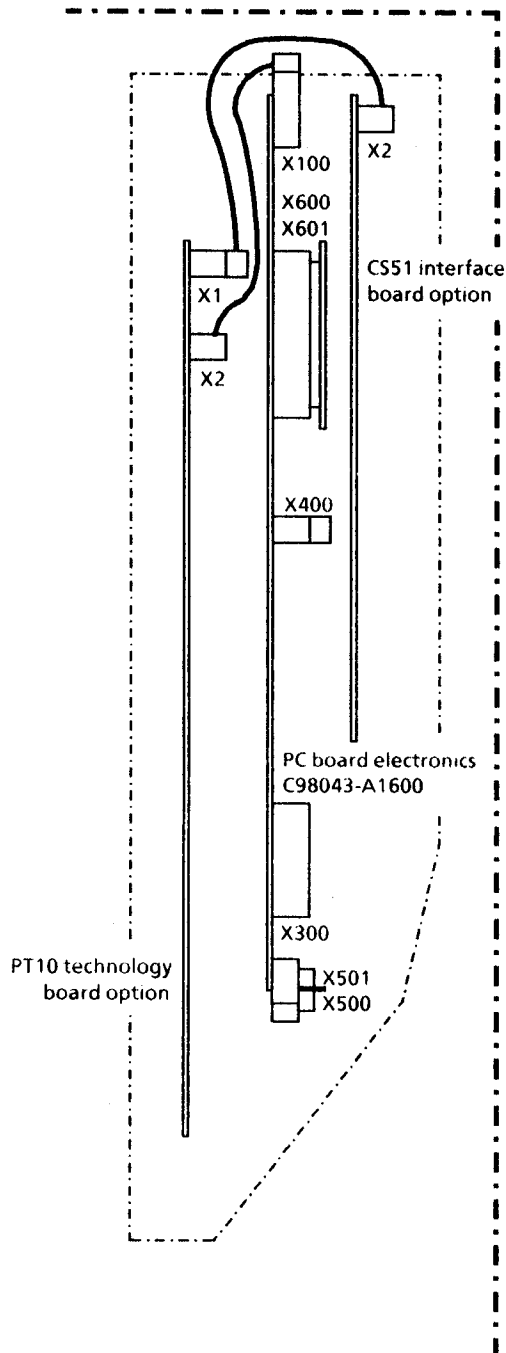

Before inserting the option board, the support element located at the upper end of the electronics pan must be removed. To realize this, the lower side of the support element is depressed so that the plastic tongue moves inwards and withdraws the support element towards the top. The option boards are inserted in the electronics holder at the appropriate position, and are retained in place using two captive screws. The support element is then re-inserted at the appropriate place.

The electrical connection is established using ribbon cables, soldered at one side and more specifically, from the PT10 option board, connector X2 to the electronics PC board, connector X100 and the CS51 option board, connector X2 to option board PT10, connector X1.

If only the CS51 option board is to be inserted, connector X2 should be connected with the electronics PC board, connector X100.

If only the PT10 option board is inserted, then only connector X2 has to be connected to the electronics PC board, connector X100.

### 5.3.3.2 Mounting unit for mounting supplementary boards on the 15A converter (Order No.: 6RX1240-0AM75)

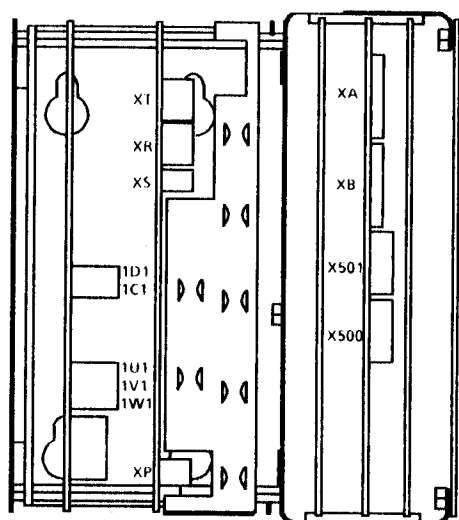
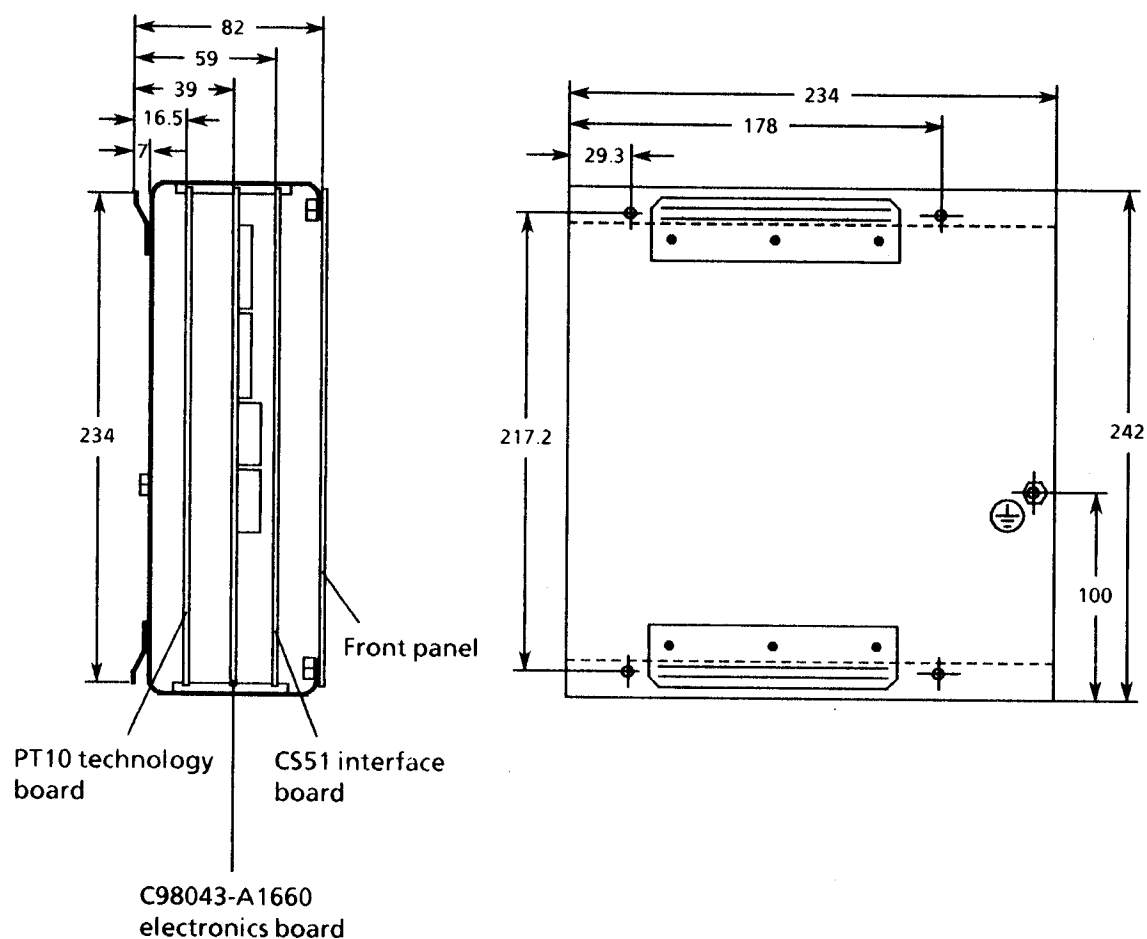

For 15A converters, to install the PT10 and/or CS51 supplementary boards, an additional installation pan is required. This can either be bolted to the basic converter (refer to the adjacent drawing), or can be inserted, together with the SIMOREG converter, into an ES902C rack.

Before mounting the pan, the front panel and electronics board (A1600) should be removed from the basic converter, and mounted at the position provided on the mounting pan. The mounting pan can then be bolted to the SIMOREG converter. The boards are interlocked in the electronics pan using pre-mounted devices and screws. The electronics board (A1600) and power supply board (A1608) are connected through ribbon cable X101 supplied.

The mounting pan and electronics board (A1600) should be connected with the converter ground.

The option boards are electrically connected as for the 30 A to 1200 A converters (refer to Section 5.3.3.1).

5.3.4 Motor interface (Order No.: 6RX1240-0AL00)

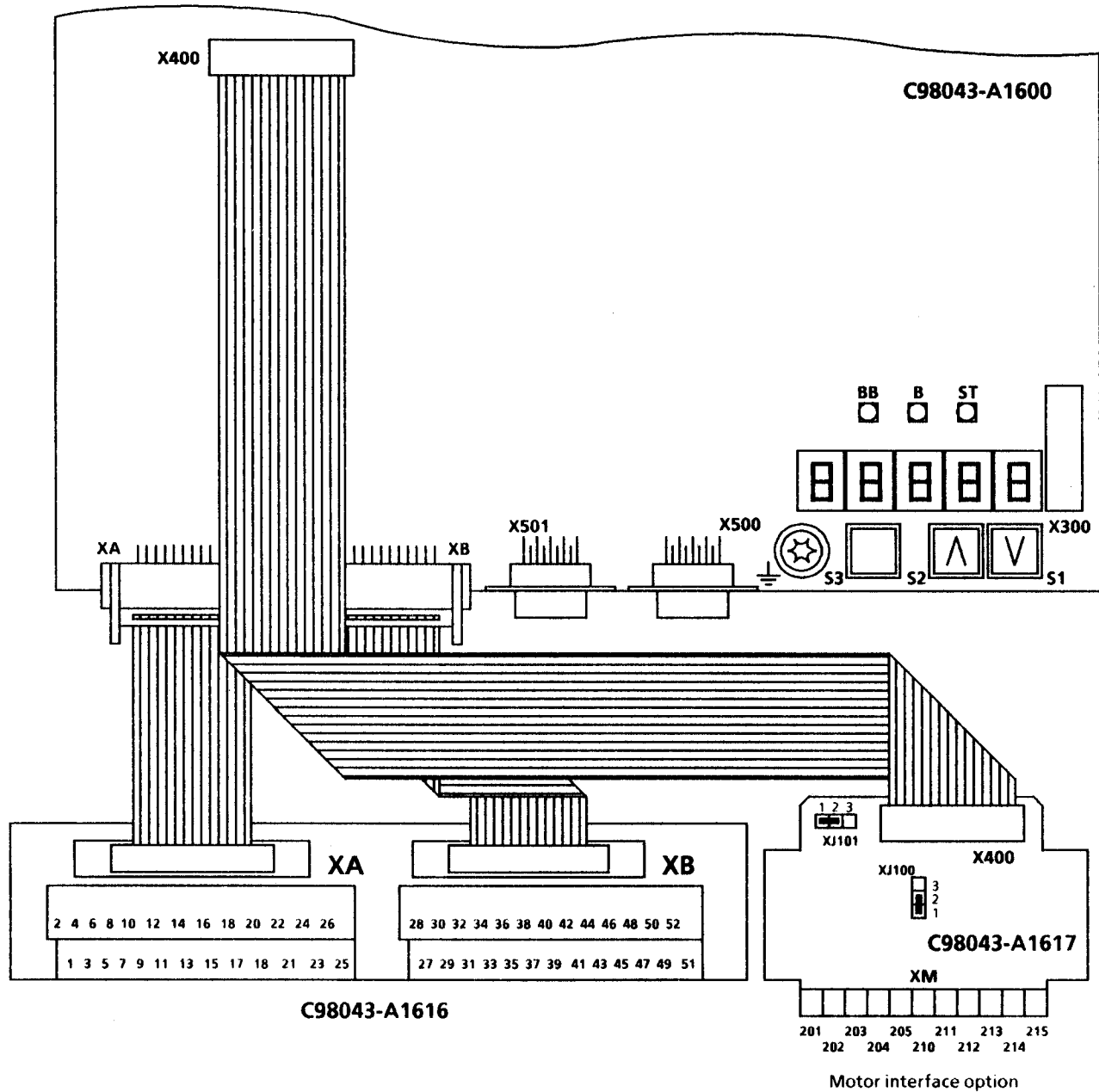

The motor interface option is snapped onto the rail next to the terminal block. Connector X400 is connected with connector X400 on the electronics PC board using a ribbon cable. Plug-in jumpers XJ100 and XJ101 on the motor interface are in the 1-2 setting when supplied (binary inputs of the motor sensor system are non-floating, motor temperature sensor type KTY84 or PTC).



5.3.5 Interface expansion (Order No.: 6RX1240-0AL01)

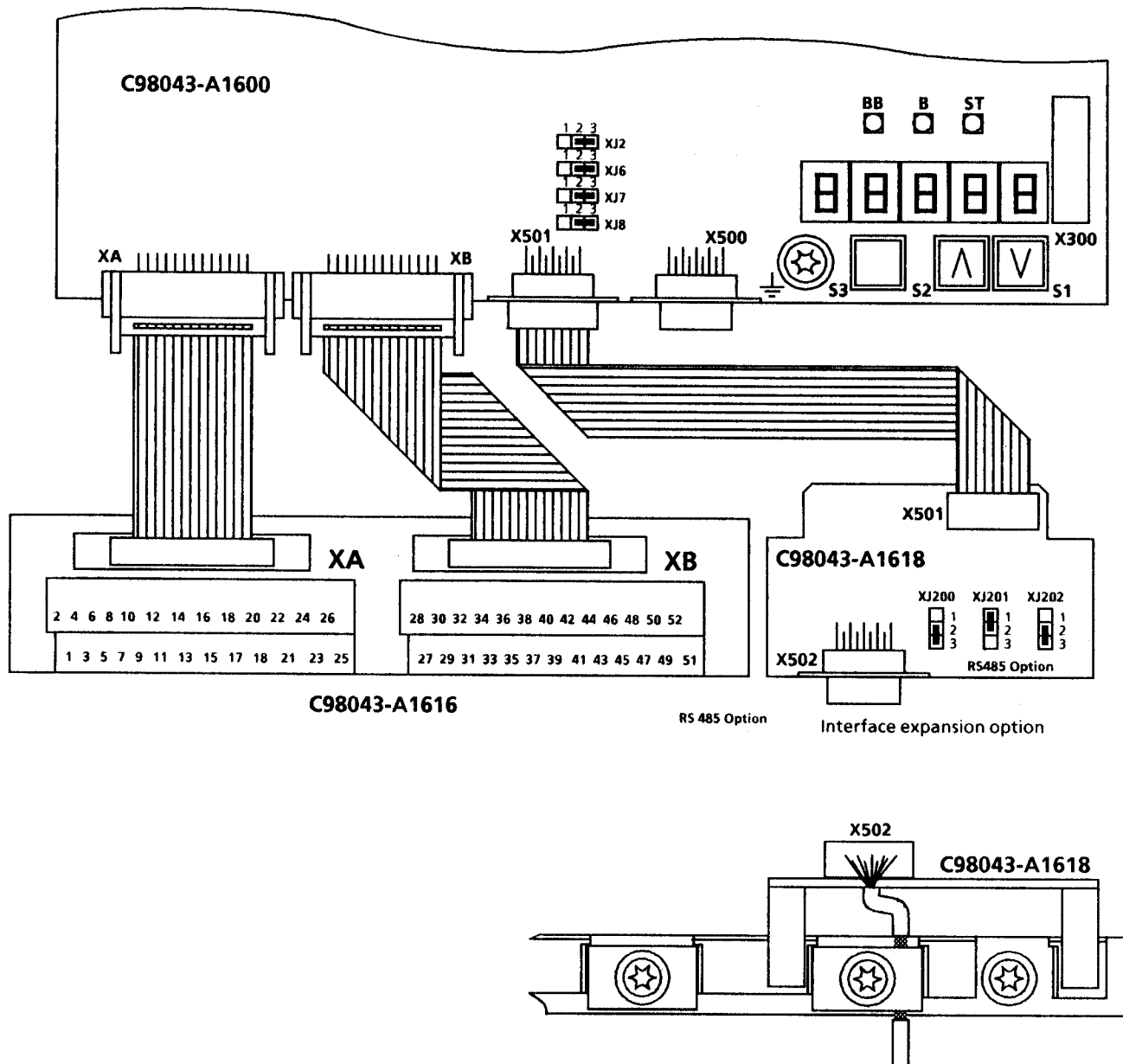

The interface expansion option is snapped onto the rail next to the terminal block. Connector X501 is connected with connector X501 on the electronics PC board using a ribbon cable. Plug-in jumpers XJ200 and XJ202 are in the 2-3 setting, and XJ201 in the 1-2 setting on the interface converter when supplied (no bus termination). Plug-in jumpers XJ2, XJ6, XJ7 and XJ8 should be brought into the 2-3 setting on the electronics PC board.

The interface cable at connector X502 must be screened and the screen must be grounded at both ends.

5.3.6 Two-tier configuration of motor interface and interface expansion in the SIMOREG converter (mounting set No.: 6RX1240-0AM74)

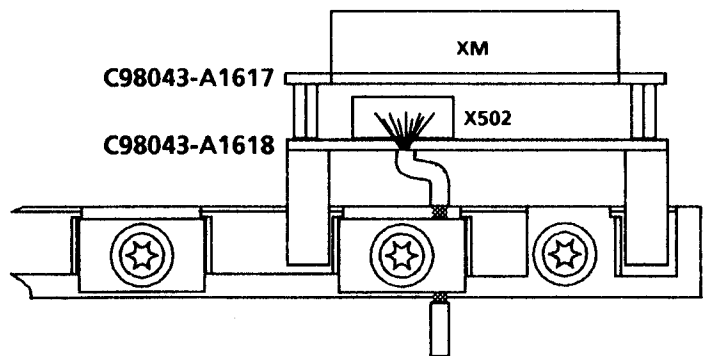
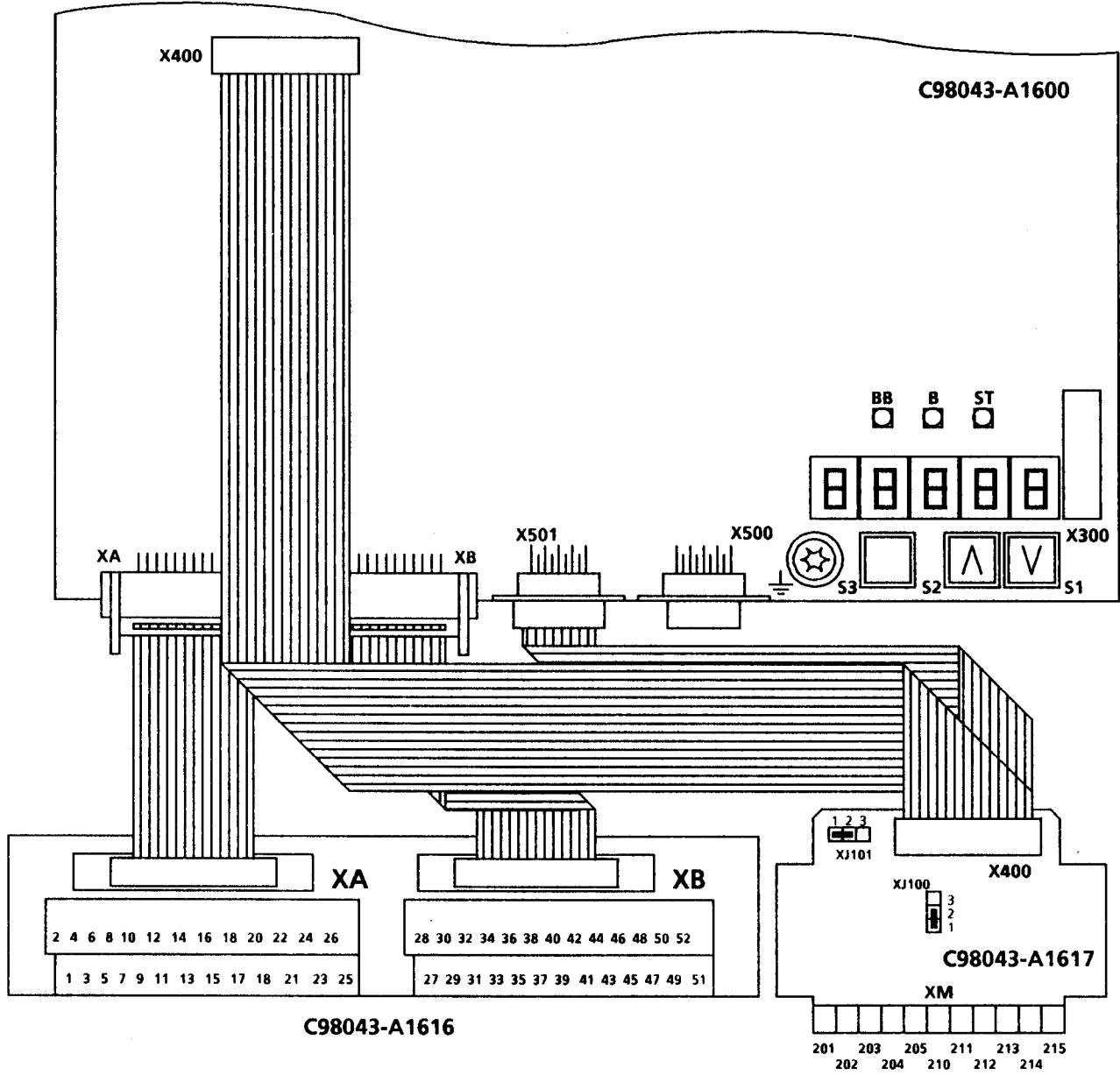

5.3.7 Mounting the terminal block and motor interface outside the converter

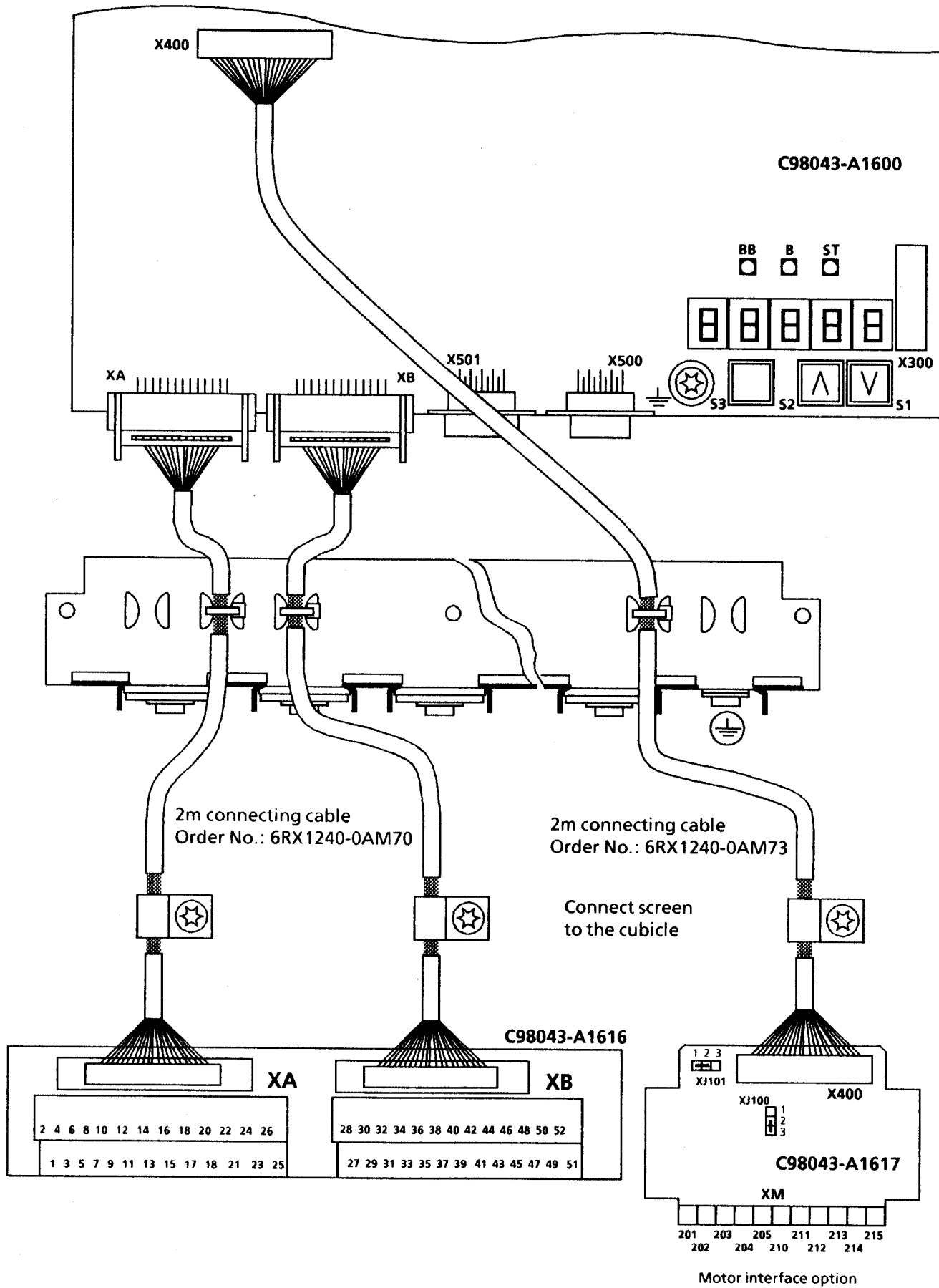



## 6 Connecting-up



### WARNING

This converter contains hazardous voltages and rotating mechanical components (fans). Death, severe bodily injury and material damage can occur if the instructions in this Manual are not observed.

The unit is at a dangerous potential even when the converter line contactor is open. The gating board (the PC board, mounted in the lower section of the housing) contains many circuits at hazardous voltage levels.

The user is responsible for installing the converter, motor, transformer and the other equipment according to the relevant safety regulations (e.g. DIN, VDE) as well as all other national and local regulations and specifications regarding cable dimensioning and protection, grounding, isolator, overcurrent protection etc.



On the customer side, a dangerous voltage level can be connected to a signaling relay.

The converters **MUST NOT** be connected to a supply with earth-leakage circuit-breaker (VDE 0160, Section 6.5) as a DC component can be included in the fault current when a fault to frame or ground occurs, which either prevents or hinders a higher-level earth leakage-circuit breaker from tripping. In this case, all loads connected to this earth-leakage circuit-breaker also have no protection.

An operating stop is not realized in the sense of the binding regulations (DIN VDE 0113, Section 1) if the drive is only shutdown using terminal 37 on A1600 (ON/OFF) or terminal 38 on A1600 (enable). If there is a fault in the converter electronics the motor could accidentally start to rotate.



### WARNING

The external surfaces of ungrounded converters might be at a dangerous potential. This could result in death, bodily injury or significant material damage.



If the converter (cubicle or chassis unit) is installed so that it is not grounded, to ensure the safety of operating personnel, a grounding cable must be connected to the housing. The motor frame, transformer housing and the operator control section must also be grounded. The safety regulations (e.g. DIN, VDE) as well as all other relevant national and local regulations must be observed regarding the converter grounding.

All rotating components must be provided with protective guards.

**NOTE**

In order to ensure noise immunity (EMC), the converter grounding stud should be electrically connected to the cubicle through the shortest possible connecting cable.

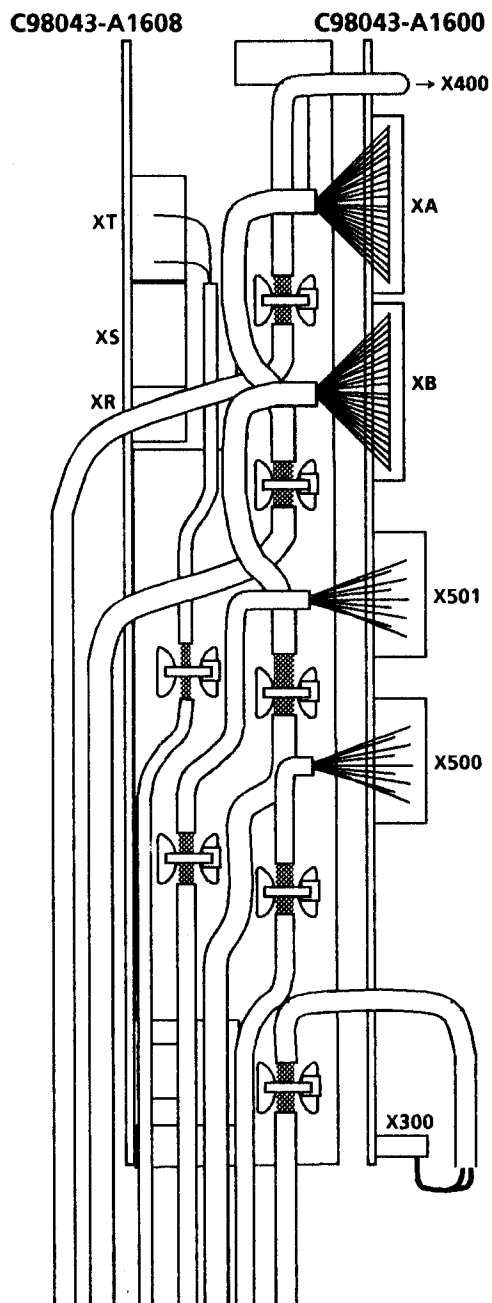
**6.1 Instructions for connecting screened control cables****Converter type D.../15**

Converter type D.../30-600

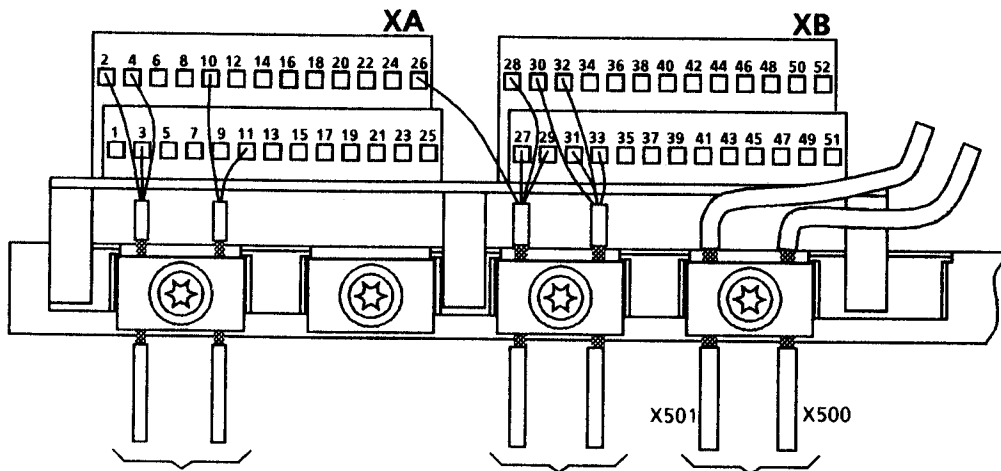

The cables which are clamped under the same cable clamp must have approximately the same diameter.

The connecting cable of connectors X500 and X501 can also be routed under the terminal block.

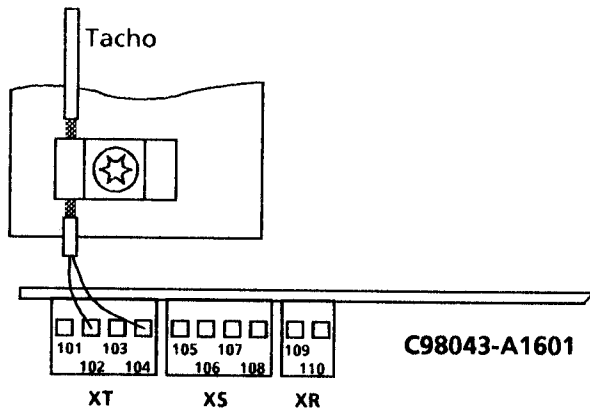
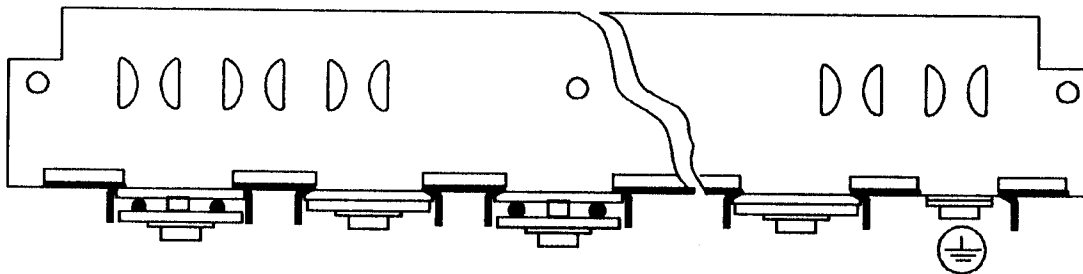

## Converter type D.../640 - 1200

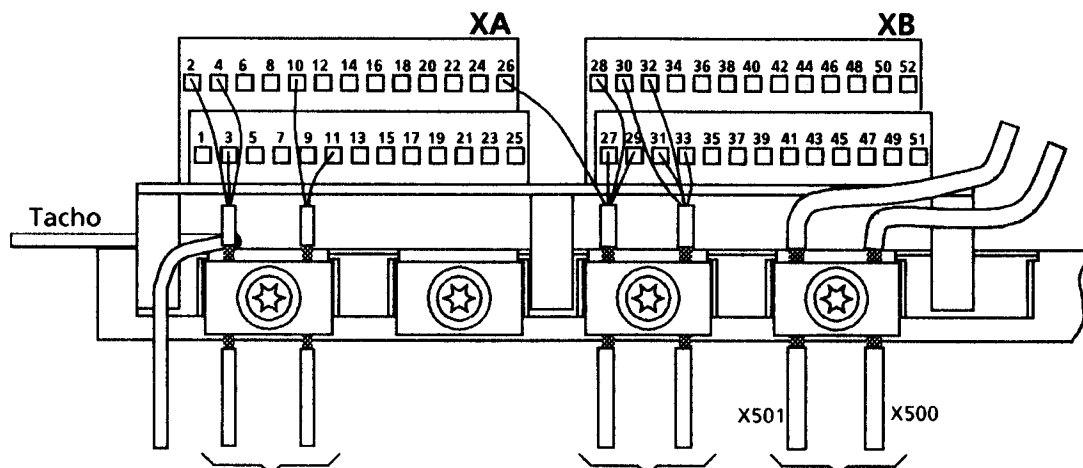

The cables which are clamped under the same cable clamp must have approximately the same diameter.

The connecting cable of connectors X500 and X501 can also be routed under the terminal block.

To tachogenerator connection on A1602 (terminal XT)

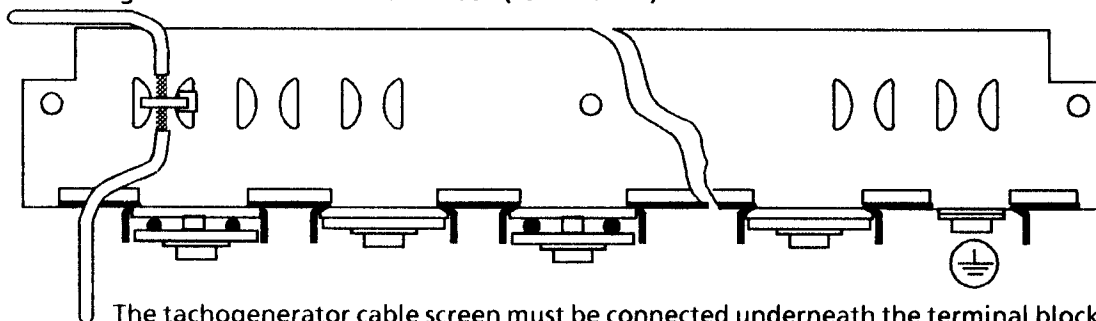

The tachogenerator cable screen must be connected underneath the terminal block using the cable ties provided and the terminal block must be removed for this purpose.

### HINWEIS

The converters should be wired-up according to the binding connecting terminal diagram or recommended connection. Setpoint and actual value cables should be screened, and routed separately from load voltage cables. Control cables and field cables must be routed in separate cable ducts.

AC contactors should be provided with RC elements in the SIMOREG cubicles and adjacent cubicles (or with quenching diodes for DC contactors).

The connecting cables at the serial interface of the electronics board (X500, X501) and the interface expansion (X502) must be screened. The screens must be grounded at the locations provided where the cable enters the converter. The screens must also be grounded at the other cable ends.

When the converter is connected-up according to Section 6.2, the DC output is not electrically isolated from the supply.



### 6.2 Block diagrams with recommended connection

#### Converter type D.../15

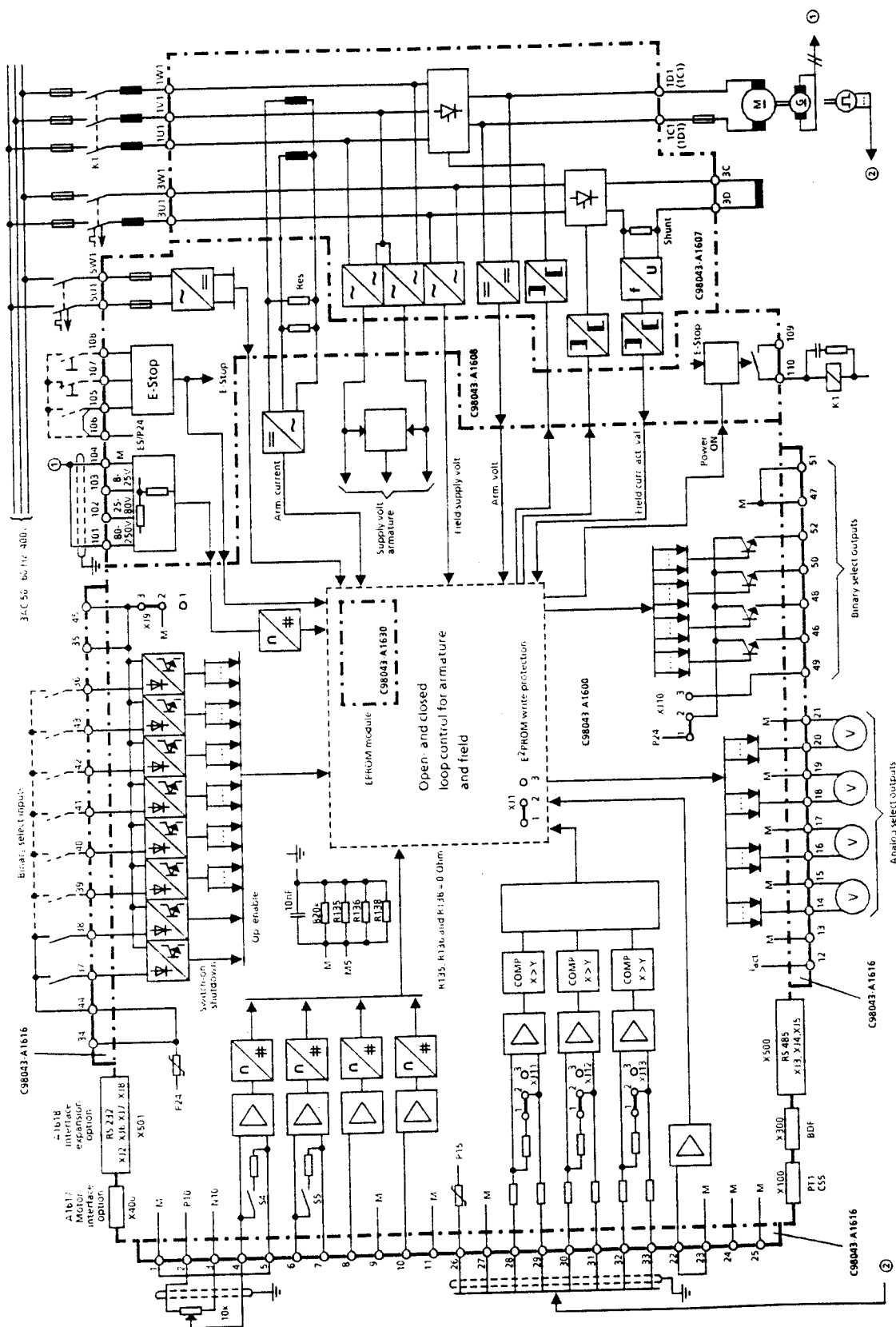

# Converter type D.../30 - 600

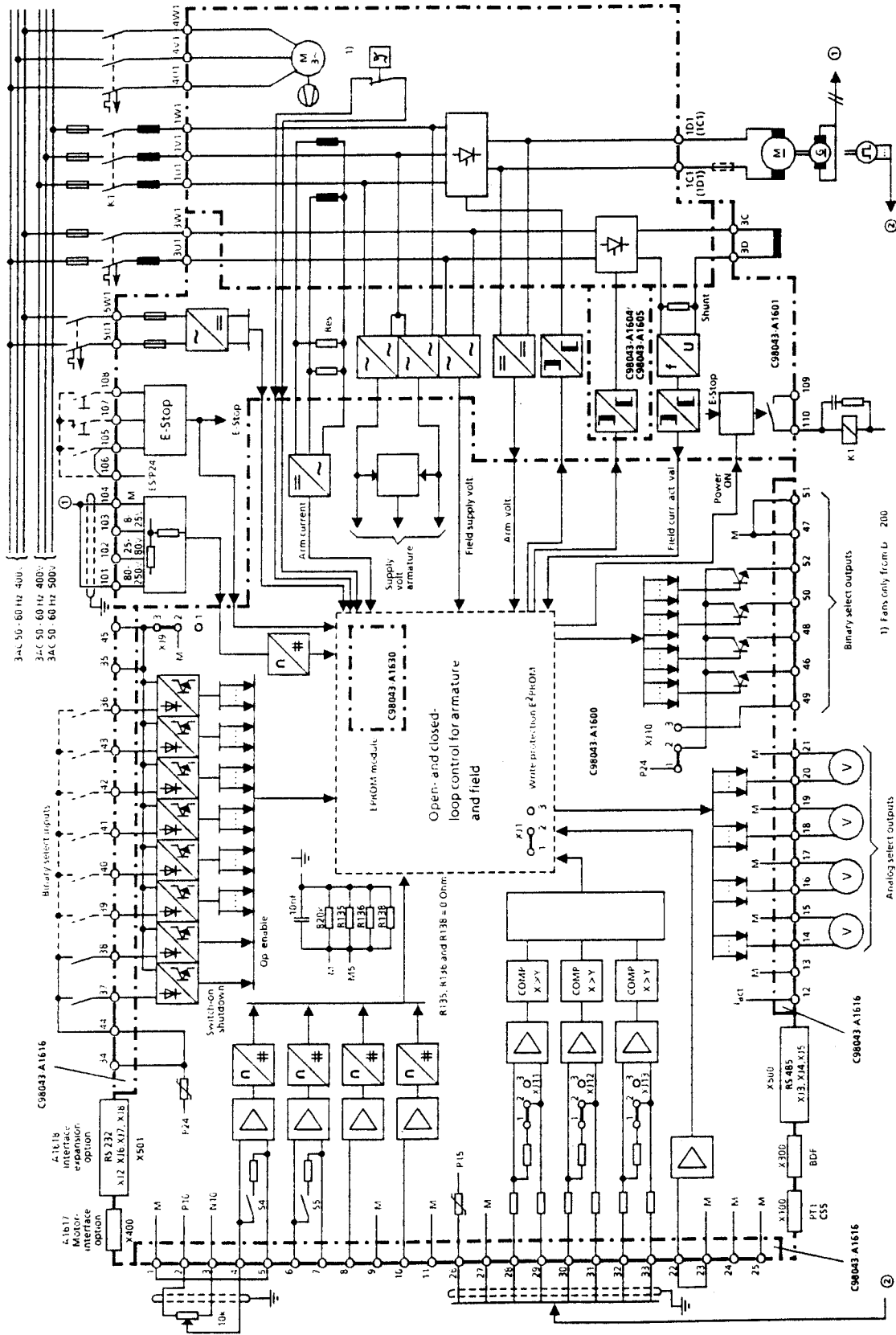

# Converter type D.../640 - 1200

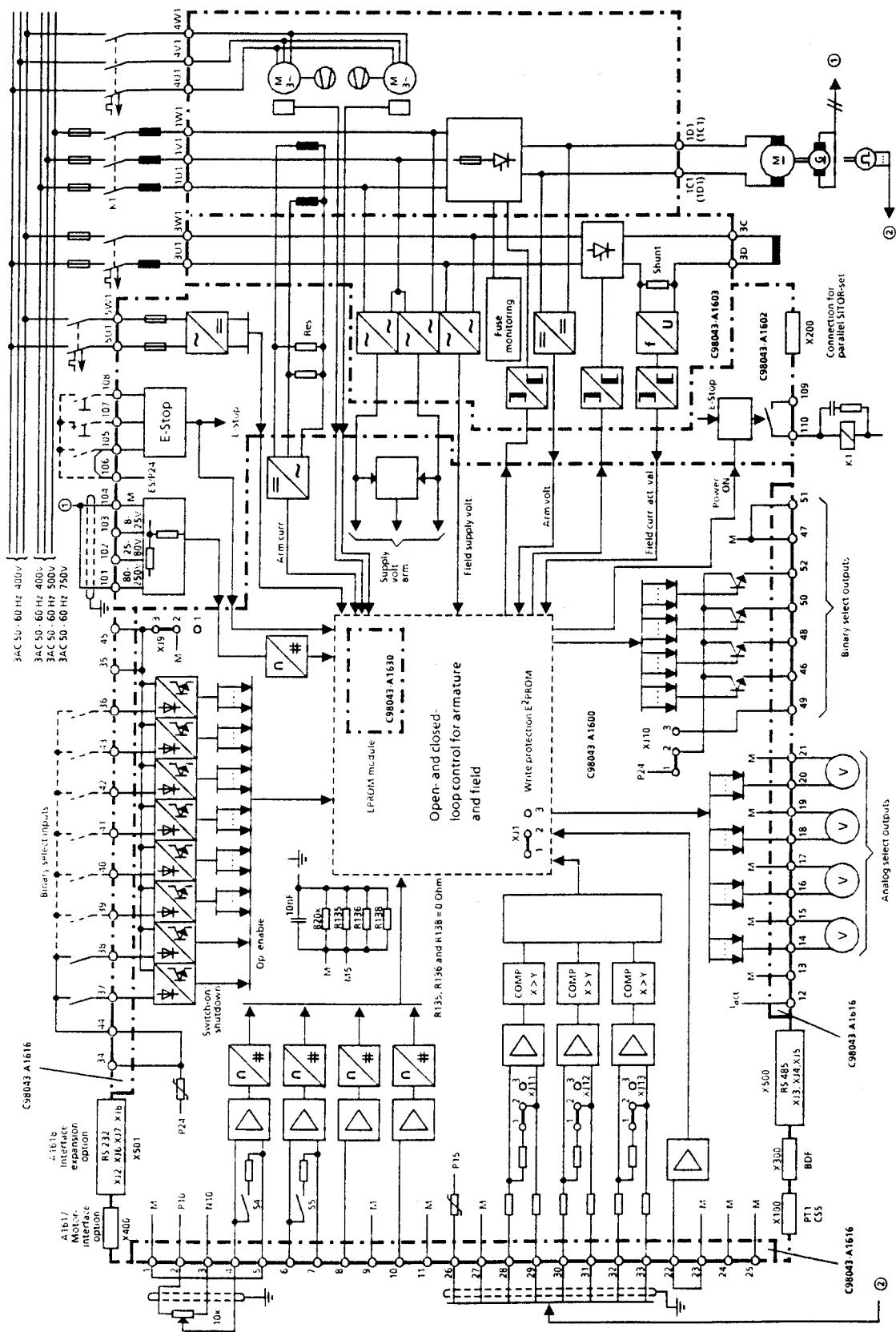

### 6.3 Connecting a SIMOREG converter in parallel with a 6QG35 SITOR thyristor set

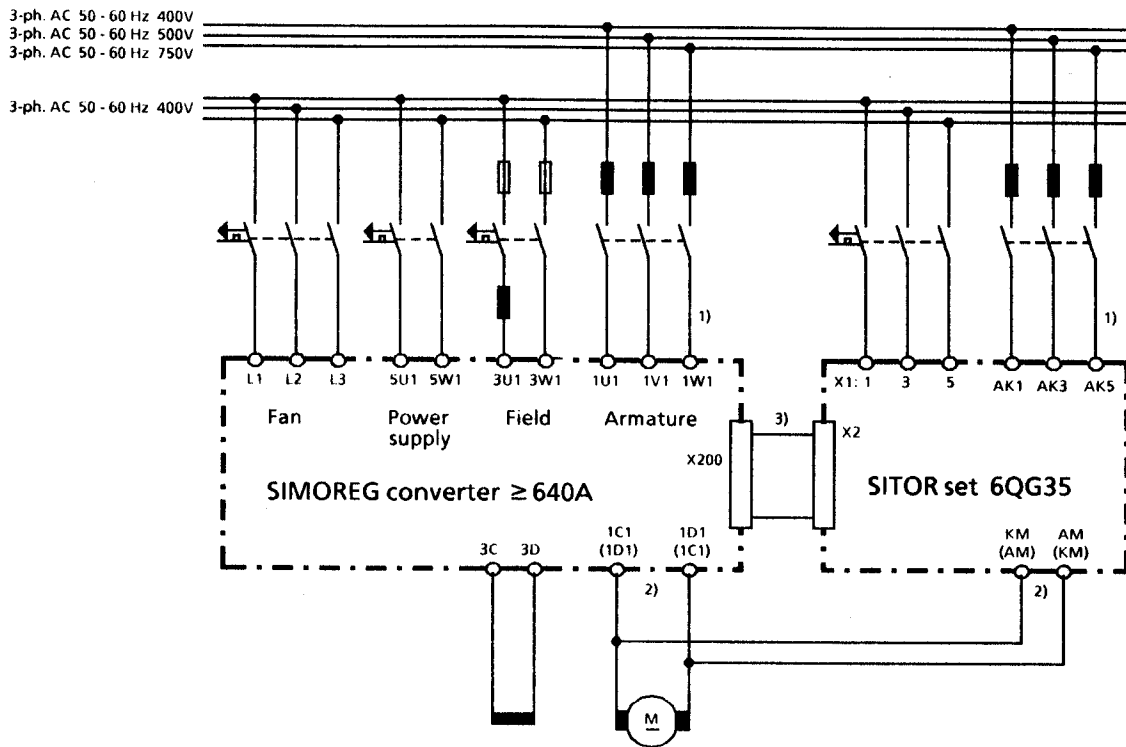

- 1) The same phase sequence is required between 1U1 / 1V1 / 1W1 and AK1 / AK3 / AK5.
- 2) The same phase sequence is required between 1C1 / 1D1 and KM / AM.
- 3) Ribbon cable 6RY1247-0AA14 (1m) or 6DD1684-0BH1 (2m), X200 on board A1602 to X2 on the SITOR set.

Separate commutating reactors are required for the SIMOREG converter and SITOR set for current distribution.

**Caution**, only units with the same current ratings can be connected in parallel!

Permissible output current with the parallel circuit:

- a) When the units are mounted one above the other with a common fan module

$$I_{\max} = 2 \times I_{\text{rated (SIMOREG)}} \times 0.85$$

- b) When the units are mounted next to each other with separate fan modules

$$I_{\max} = 2 \times I_{\text{rated (SIMOREG)}}$$

Setting parameter P072 (rated converter DC current):

Sum of the rated DC currents for the SIMOREG converter and SITOR set =  $2 \times I_{\text{rated (SIMOREG)}}$   
 $((n + 1) \times I_{\text{rated (SIMOREG)}}$  for n SITOR sets in parallel, n = 1 to 5)

Setting parameter P074 (control word for the power section):

x1x, as 1 parallel SITOR set is available (xnx for n parallel SITOR sets, n = 1 to 5).

Setting parameter P171 and P172 (current limit):

$$\text{Maximum value of P171 and P172} = \frac{I_{\max}}{\text{Rated motor armature current}} \times 100 \%$$

For ambient temperatures above 35°C and installation altitudes above 1000m,  $I_{\max}$  should be further reduced according to Section 3 and P077 in Section 9.2.

### 6.4 Power connections

#### Converter type D... / 15 Mreq-GeG6V62

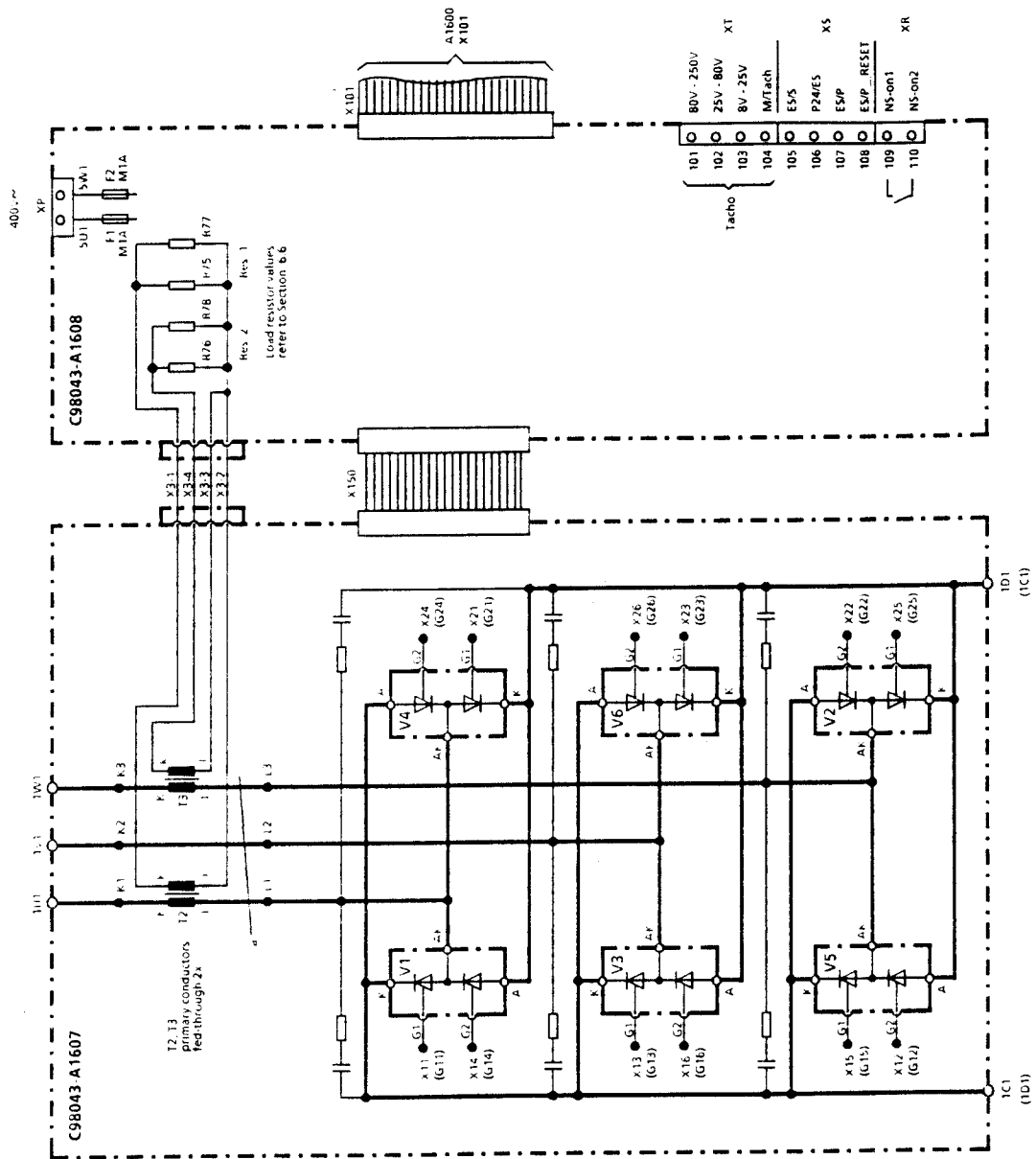

a = YF1.5  
 All gating cables are S-flex 10, 105-0 5mm<sup>2</sup>

Arrangement of the thyristor modules

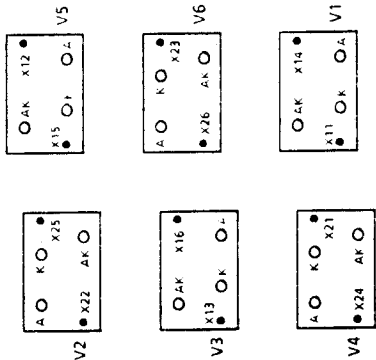

Converter type D... / 30 - 250 Mre-GeE(F)6S22

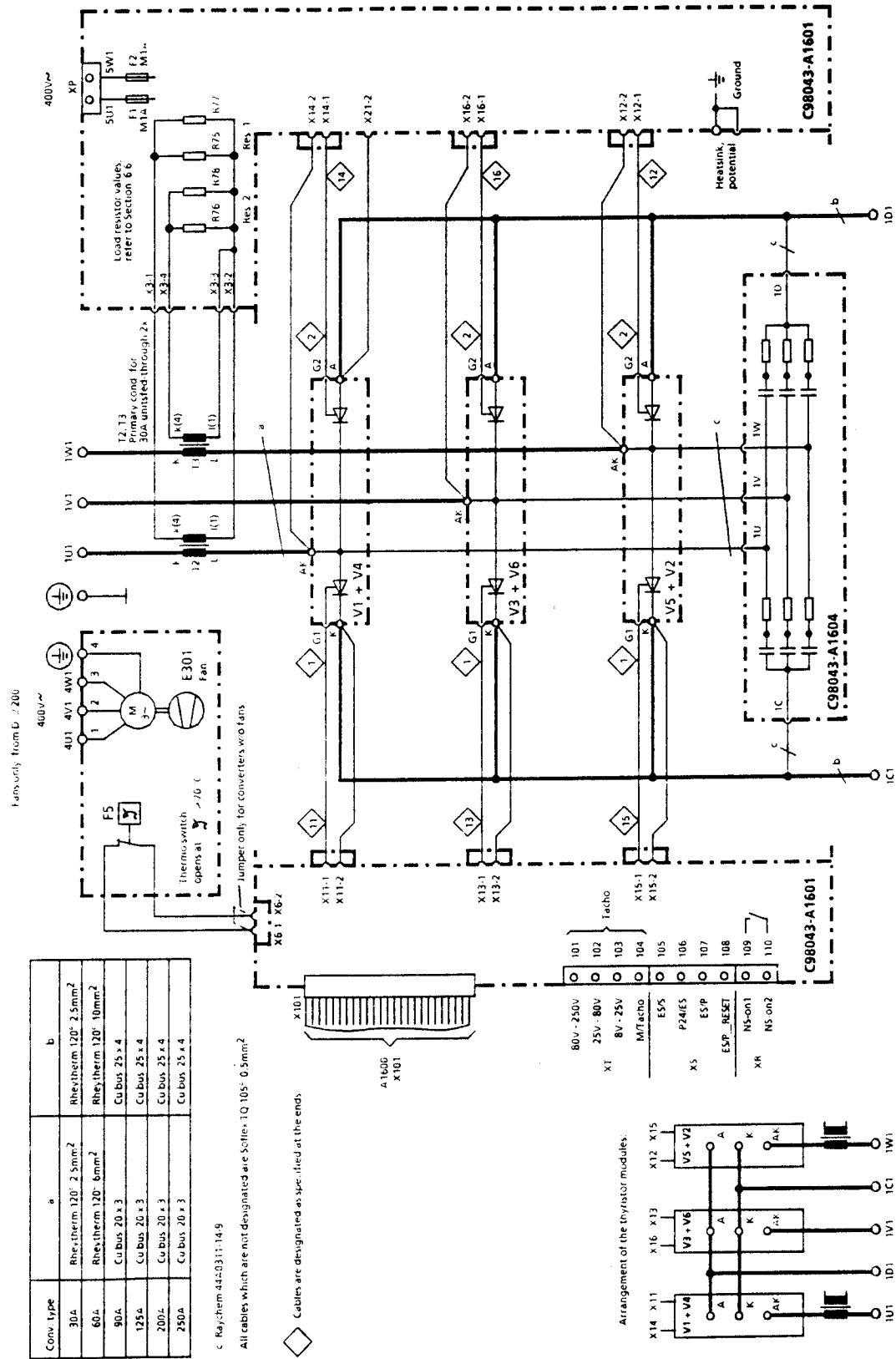

| Conv. type | a                                    | b                                    |
|------------|--------------------------------------|--------------------------------------|
| 30A        | Rhe.therm. 120° - 2.5mm <sup>2</sup> | Rhe.therm. 120° - 2.5mm <sup>2</sup> |
| 60A        | Rhe.therm. 120° - 6mm <sup>2</sup>   | Rhe.therm. 120° - 10mm <sup>2</sup>  |
| 90A        | Cu bus 20 x 3                        | Cu bus 25 x 4                        |
| 125A       | Cu bus 20 x 3                        | Cu bus 25 x 4                        |
| 200A       | Cu bus 20 x 3                        | Cu bus 25 x 4                        |
| 250A       | Cu bus 20 x 3                        | Cu bus 25 x 4                        |

c Raychem 444-0311: 14.9

All cables which are not designated are Solflex TQ 105 - 0.5mm<sup>2</sup>

◆ Cables are designated as specified at the ends.

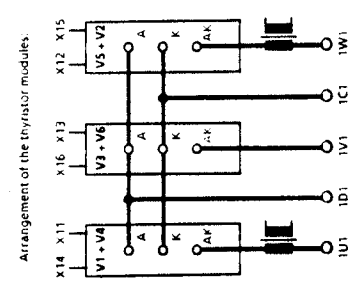

Converter type D... / 30 - 250 Mreq-GeG(F)6V62

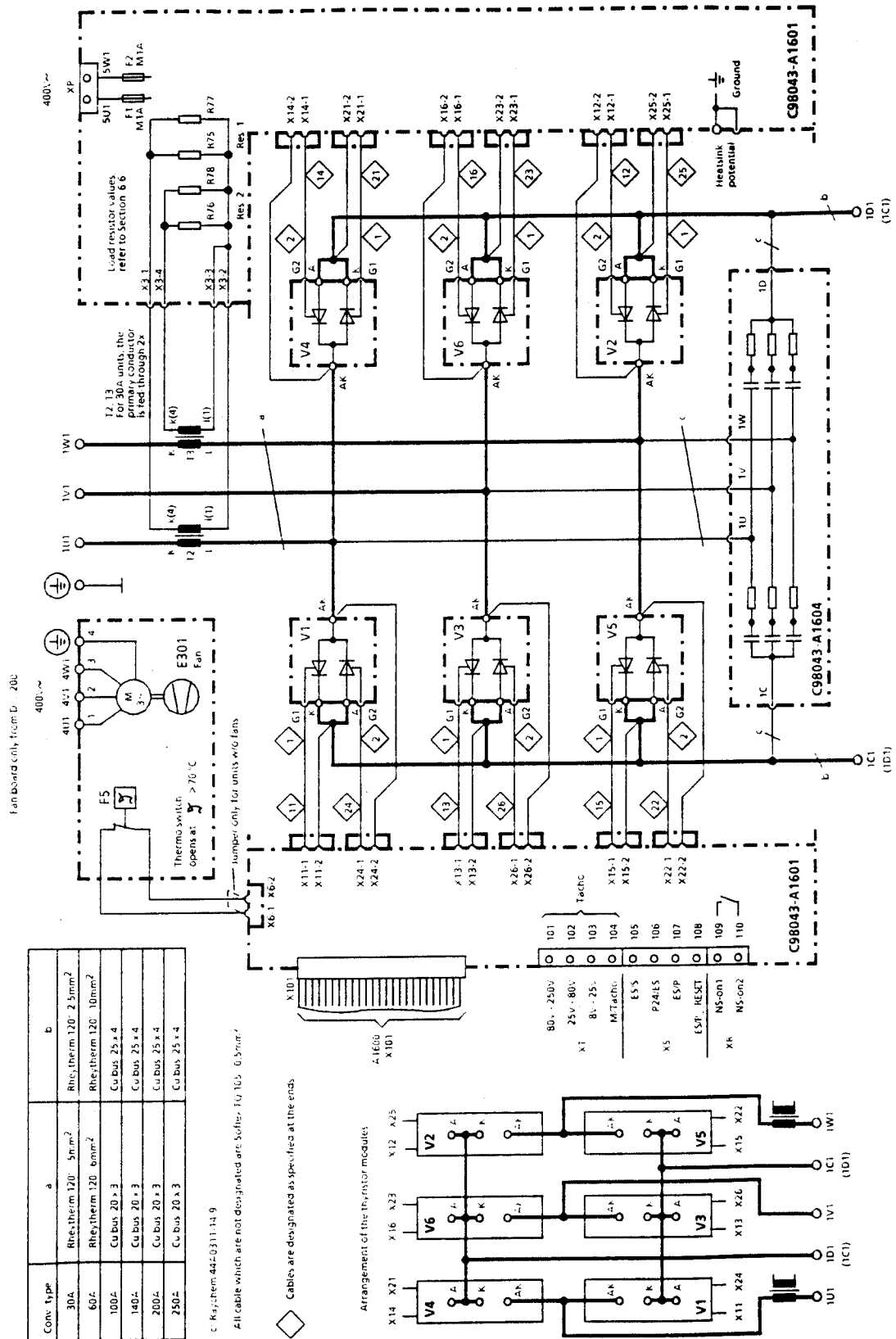

| Conv. type | a                                | b                                  |
|------------|----------------------------------|------------------------------------|
| 30A        | Rhe.therm 120 - 5mm <sup>2</sup> | Rhe.therm 120 - 2.5mm <sup>2</sup> |
| 60A        | Rhe.therm 120 - 6mm <sup>2</sup> | Rhe.therm 120 - 10mm <sup>2</sup>  |
| 100A       | Cu bus 20 x 4                    | Cu bus 25 x 4                      |
| 140A       | Cu bus 20 x 3                    | Cu bus 25 x 4                      |
| 200A       | Cu bus 20 x 3                    | Cu bus 25 x 4                      |
| 250A       | Cu bus 20 x 3                    | Cu bus 25 x 4                      |

c. Rev. chem 44E-0311-14-9

All cable which are not designated are: Softler, 14.70.5 0.5mm<sup>2</sup>

⬡ Cables are designated as specified at the ends.

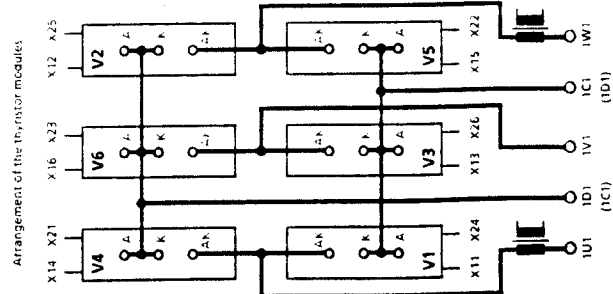

Converter type D... / 400 - 600 Mre-GeEF6S22

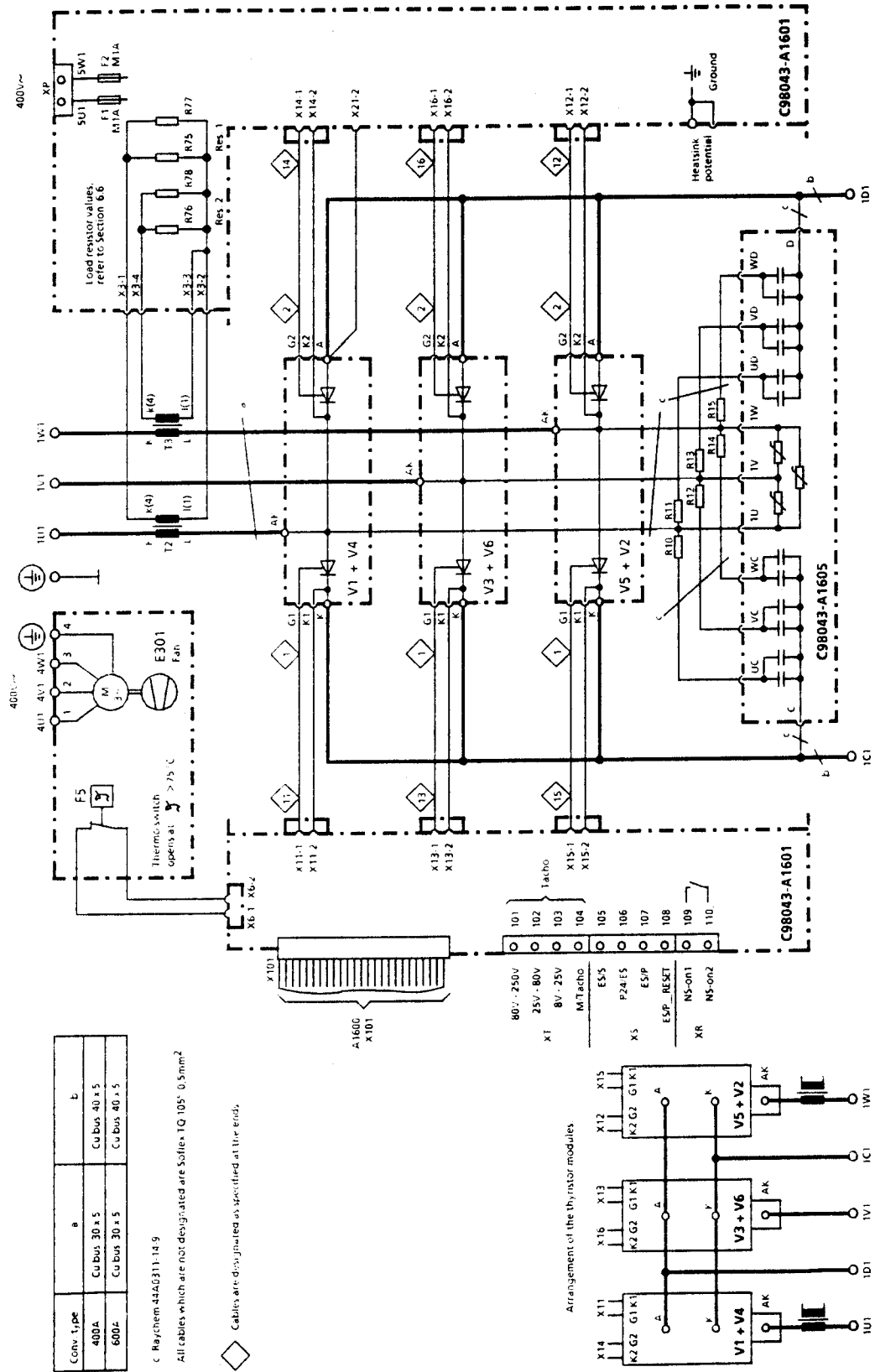

| Conv. type | a             | b             |
|------------|---------------|---------------|
| 400A       | Cu bus 30 x 5 | Cu bus 40 x 5 |
| 600A       | Cu bus 30 x 5 | Cu bus 40 x 5 |

c Raychem 44A0311-14-9  
 All cables which are not designated are Solflex TQ 105<sup>2</sup> 0.5mm<sup>2</sup>

◇ Cables are designated as specified at the ends

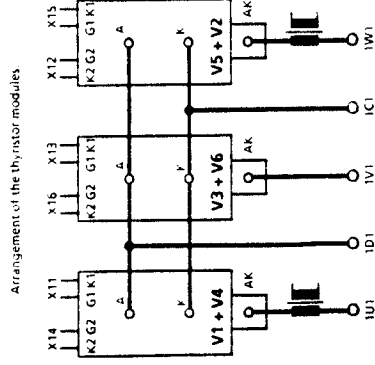



# Converter type D... / 400 - 600 Mreq-GeGF6V62

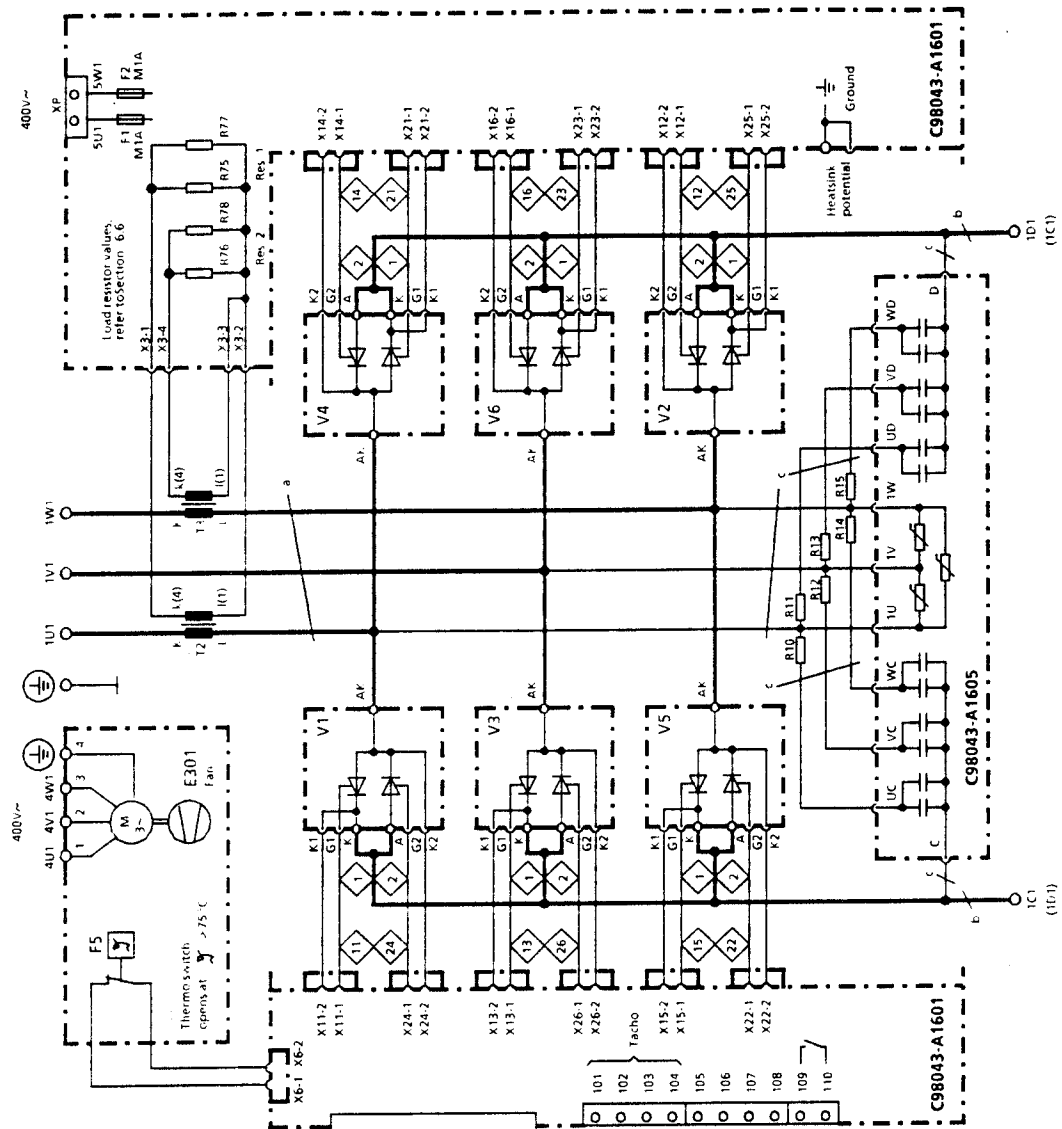

| Conv. type | a             | b             |
|------------|---------------|---------------|
| 400A       | Cu bus 30 x 5 | Cu bus 40 x 5 |
| 600A       | Cu bus 30 x 5 | Cu bus 40 x 5 |

c: Raychem 44A0311-14 9  
 All cables which are not designated are Solflex IQ 105<sup>o</sup> 0.5mm<sup>2</sup>

◇ Cables are designated as specified at the ends

Arrangement of the thyristor modules

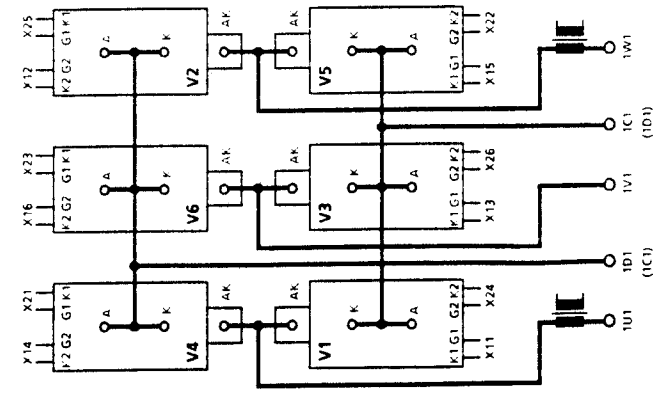

Converter type D... / 640 - 1200 Mre-GeEF6S22

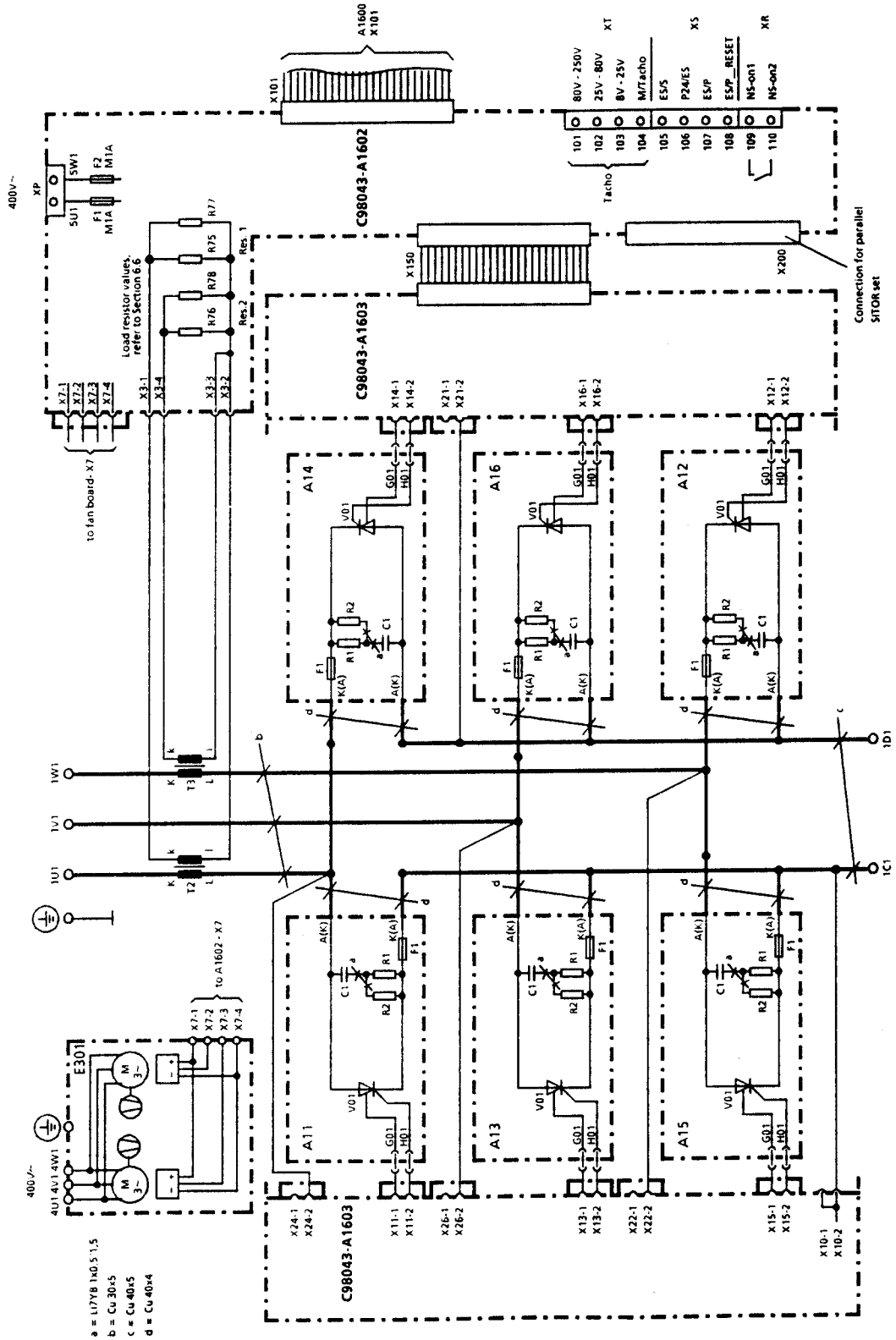

# Converter type D... / 640 - 1200 Mreq-GeGF6V62

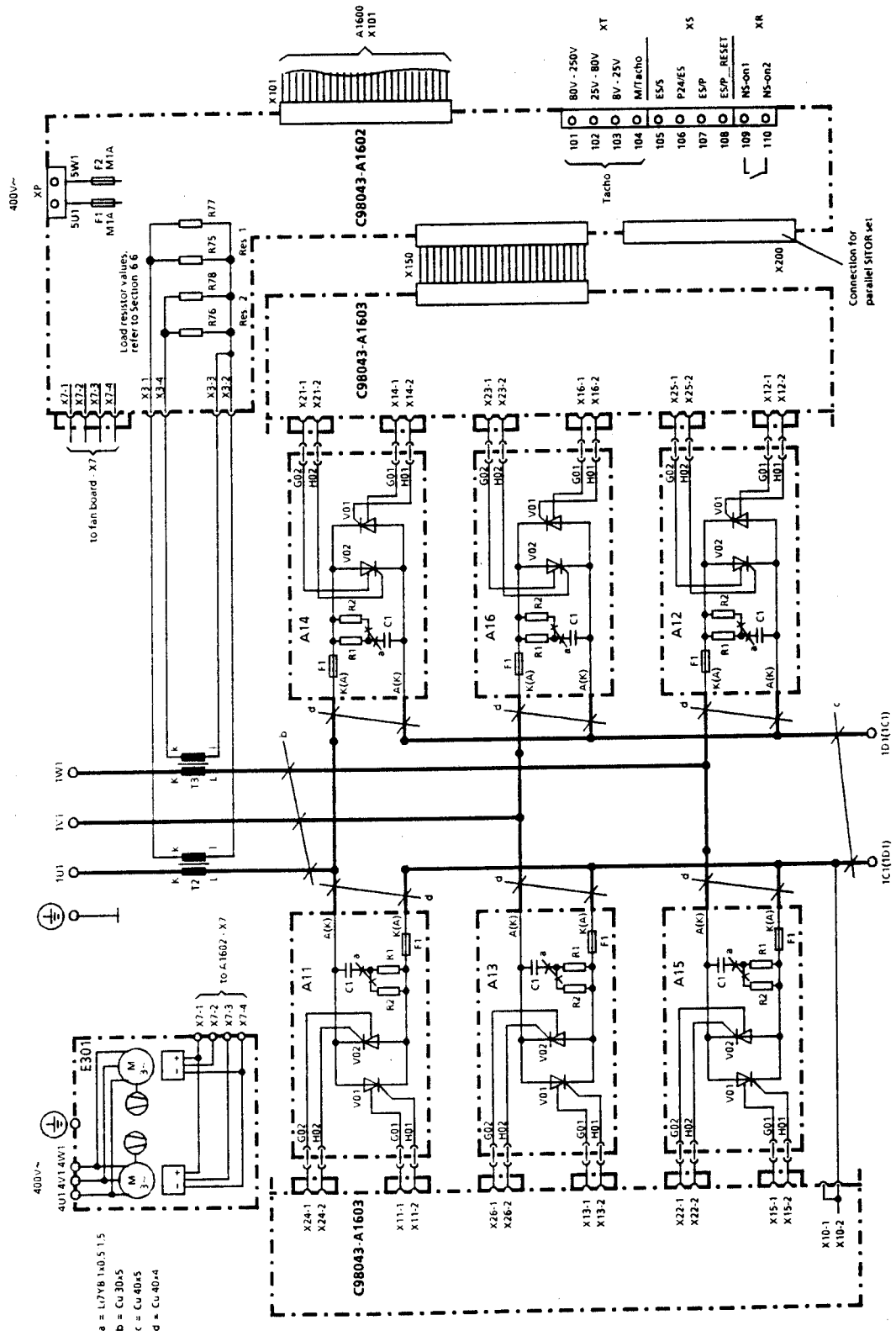

## 6.5 Field supply

## Converter type D.../15

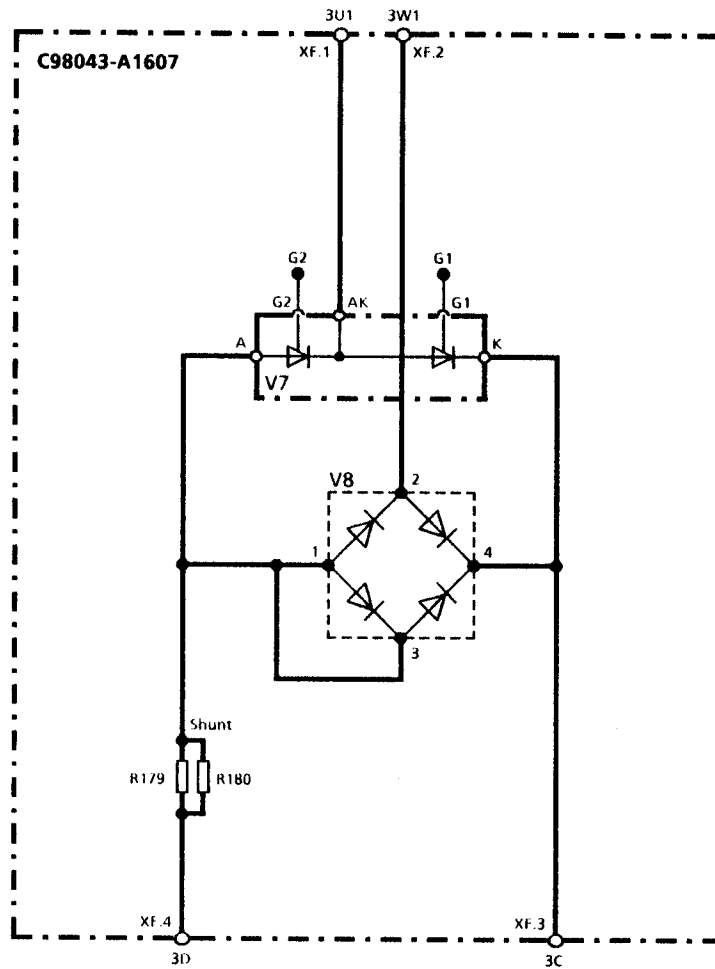

Gating cables, SOFLEX TQ, 105°C 0.5mm<sup>2</sup>

| Rated field DC current | Shunt mounted on A1607 |
|------------------------|------------------------|
| 1A                     | R180                   |
| 2A                     | R179                   |
| 3A                     | R179, R180             |

Converter type D.../30 - 600

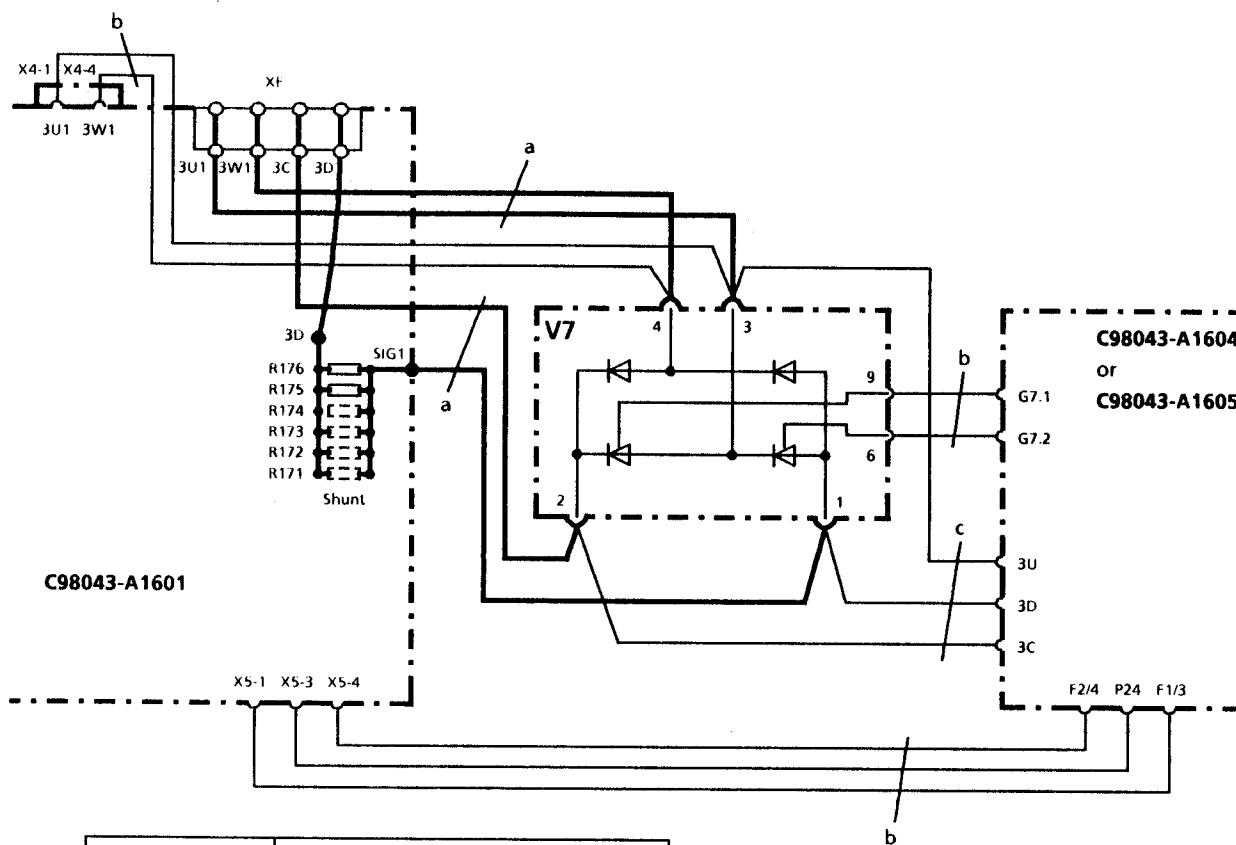

| Rated field DC current | Shunt mounted on A1601             |
|------------------------|------------------------------------|
| ≤ 2,5A                 | R176                               |
| 5A                     | R175, R176                         |
| 10A                    | R174, R175, R176                   |
| 15A                    | R173, R174, R175, R176             |
| 20A                    | R172, R173, R174, R175, R176       |
| 25A                    | R171, R172, R173, R174, R175, R176 |

a: Rheytherm 120°C 2,5mm<sup>2</sup>  
 b: Soflex TQ 105°C 0,5mm<sup>2</sup>  
 c: Rheytherm 120°C 1,5mm<sup>2</sup>

Converter type D... / 640 - 1200

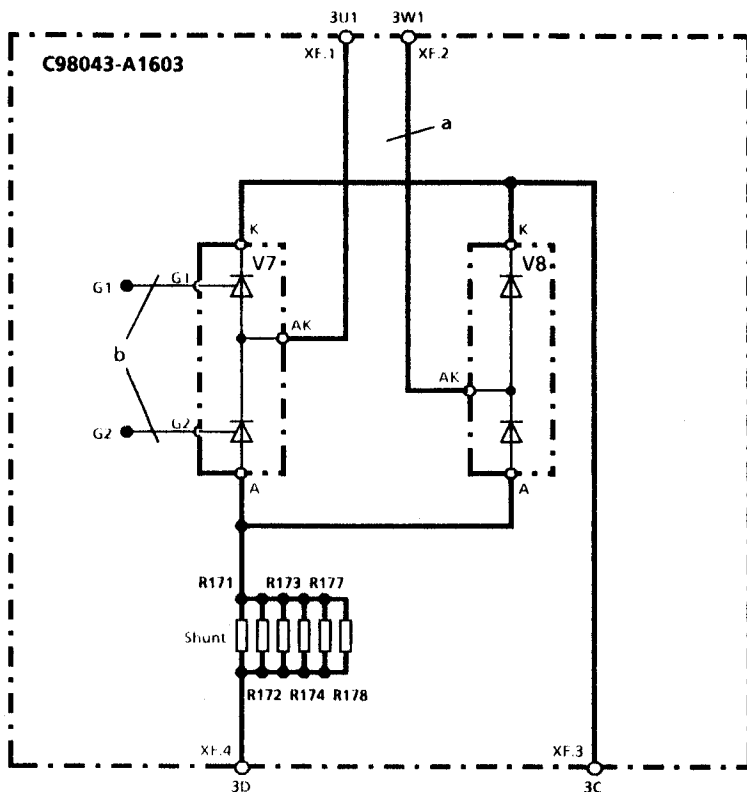

| Rated field DC current | Shunt mounted on A1603             |
|------------------------|------------------------------------|
| 5A                     | R178                               |
| 10A                    | R177, R178                         |
| 15A                    | R174, R177, R178                   |
| 20A                    | R173, R174, R177, R178             |
| 25A                    | R172, R173, R174, R177, R178       |
| 30A                    | R171, R172, R173, R174, R177, R178 |

a: N4GAF 6mm<sup>2</sup>  
 b: Soflex TQ 105°C 0,5mm<sup>2</sup>

6.6 Load and shunt resistors (location, refer to the subsequent pages)

**IMPORTANT NOTE**

We do not accept any liability for damage incurred due to incorrect load or shunt resistors being installed.

The current transformer is destroyed if the armature circuit load resistors (R75 to R78) are not mounted.

Spare boards are supplied without load resistors and with all shunt resistors!

| Load resistors for armature circuit on A1602 and A1601 |                          |                           |                |              |                        | Shunt resistors for the field circuit on A1607 and A1601 |                          |                |             |             |      |             |             |                                      |             |                   |  |                 |
|--|--------------------------|---------------------------|----------------|--------------|------------------------|--|--------------------------|----------------|-------------|-------------|------|-------------|-------------|--------------------------------------|-------------|-------------------|--|-----------------|
| Converter rated DC current                             | Reduced rated DC current | Current transformer ratio | Load resistors |              | Effective value        | Rated field DC current                                   | Reduced field DC current | on solder pins |             |             |      |             |             | Shunt resistors directly soldered-in |             |                   |  | Effective value |
|  |                          |                           | R75<br>R76     | R77<br>R78   |                        |  |                          | R171           | R172        | R173        | R174 | R180        | R175        | R176                                 | R179        |                   |  |                 |
| A  | A                        | 1:                        | Ω              | Ω            | Ω                      | A  | A                        | 20mΩ           | 20mΩ        | 20mΩ        | 20mΩ | 100mΩ       | 40mΩ        | 40mΩ                                 | 50mΩ        | mΩ                |  |                 |
| 15   | 10<br>5                  | 500<br>500<br>500         | 51<br>51       | 100<br>100   | 33,775<br>51<br>100    | 3  | 2<br>1                   | x<br>x<br>x    | x<br>x<br>x | x<br>x<br>x | x    | ●<br>x<br>● | x<br>x<br>x | x<br>x<br>x                          | ●<br>●<br>x | 33,3<br>50<br>100 |  |                 |
| 30   | 20<br>10                 | 1000<br>1000<br>1000      | 51<br>51       | 100<br>100   | 33,775<br>51<br>100    | 5  | 2,5                      | -<br>-         | -<br>-      | -<br>-      | -    | x<br>x      | ●<br>-      | ●<br>-                               | ●<br>-      | 20<br>40          |  |                 |
| 60   | 40<br>20                 | 2000<br>2000<br>2000      | 51<br>51       | 100<br>100   | 33,775<br>51<br>100    | 10   | 5<br>2,5                 | -<br>-         | -<br>-      | -<br>-      | ●    | x<br>x<br>x | ●<br>●<br>- | ●<br>●<br>-                          | ●<br>●<br>- | 10<br>20<br>40    |  |                 |
| 90   | 60<br>30                 | 2000<br>2000<br>2000      | 34<br>34       | 66,5<br>66,5 | 22,498<br>34<br>66,5   |  |                          |                |             |             |      |             |             |                                      |             |                   |  |                 |
| 100  | 67<br>32                 | 2000<br>2000<br>2000      | 30<br>30       | 61,9<br>61,9 | 20,207<br>30<br>61,9   |  |                          |                |             |             |      |             |             |                                      |             |                   |  |                 |
| 125  | 82<br>41                 | 2000<br>2000<br>2000      | 24,3<br>24,3   | 48,7<br>48,7 | 16,211<br>24,3<br>48,7 |  |                          |                |             |             |      |             |             |                                      |             |                   |  |                 |
| 140  | 93<br>45                 | 2000<br>2000<br>2000      | 21,5<br>21,5   | 44,2<br>44,2 | 16,211<br>21,5<br>44,2 |  |                          |                |             |             |      |             |             |                                      |             |                   |  |                 |

R75 and R76 always have the same value, and must be removed in pairs  
 R77 and R78 always have the same value, and must be removed in pairs

● Shunt mounted  
 - Shunt not mounted  
 x Shunt not available on the board

| Load resistors for armature circuit on A1601 and A1603 |                          |                           |                | Shunt resistors for the field circuit on A1601 and A1603 |                        |   |      |      |      |      |                                      |      |      |      |                  |                 |
|--|--------------------------|---------------------------|----------------|--|------------------------|---|------|------|------|------|--------------------------------------|------|------|------|------------------|-----------------|
| Converter rated DC current                             | Reduced rated DC current | Current transformer ratio | Load resistors |  | Effective value        | A1601 on solder pins A1603 directly soldered-in |      |      |      |      | Shunt resistors directly soldered-in |      |      |      |                  | Effective value |
|  |                          |                           | R75            | R76  |                        | R77   | R78  | R171 | R172 | R173 | R174                                 | R175 | R176 | R177 | R178             |                 |
| A  | A                        | 1:                        | Ω              | Ω  | Ω                      | 20mΩ  | 20mΩ | 20mΩ | 20mΩ | 40mΩ | 40mΩ                                 | 20mΩ | 20mΩ | 20mΩ | mΩ               |                 |
| 200  | 130<br>68                | 2000<br>2000<br>2000      | 15,4<br>15,4   | 29,4   | 10,106<br>15,4<br>29,4 | -   | -    | •    | •    | •    | •                                    | •    | •    | •    | 6,67<br>10<br>20 |                 |
| 250  | 165<br>82                | 2000<br>2000<br>2000      | 12,1<br>12,1   | 24,3   | 8,078<br>12,1<br>24,3  | -   | -    | -    | -    | -    | -                                    | -    | -    | -    | 40               |                 |
| 400  | 260<br>133               | 2000<br>2000<br>2000      | 7,68<br>7,68   | 15   | 5,079<br>7,68<br>15    | •   | •    | •    | •    | •    | •                                    | •    | •    | •    | 4<br>5<br>6,67   |                 |
| 600  | 392<br>200               | 2000<br>2000<br>2000      | 5,1<br>5,1     | 10   | 3,377<br>5,1<br>10     | -   | -    | -    | -    | -    | -                                    | -    | -    | -    | 10<br>20<br>40   |                 |
| 640  | 420<br>210               | 6000<br>6000<br>6000      | 14,3<br>14,3   | 28,7   | 9,544<br>14,3<br>28,7  | •   | •    | •    | •    | •    | •                                    | •    | •    | •    | 3,33<br>4<br>5   |                 |
| 850  | 571<br>273               | 6000<br>6000<br>6000      | 10,5<br>10,5   | 22   | 7,108<br>10,5<br>22    | -   | -    | -    | -    | -    | -                                    | -    | -    | -    | 6,67<br>10<br>20 |                 |
| 860  | 571<br>279               | 6000<br>6000<br>6000      | 10,5<br>10,5   | 21,5   | 7,055<br>10,5<br>21,5  | -   | -    | -    | -    | -    | -                                    | -    | -    | -    |                  |                 |
| 1200   | 781<br>400               | 6000<br>6000<br>6000      | 7,68<br>7,68   | 15   | 5,079<br>7,68<br>15    | -   | -    | -    | -    | -    | -                                    | -    | -    | -    |                  |                 |

R75 and R76 always have the same value, and must be removed in pairs  
 R77 and R78 always have the same value, and must be removed in pairs

• Shunt mounted  
 - Shunt not mounted  
 x Shunt not available on the board



### Location of connectors, load and shunt resistors

PC board C98043-A1600

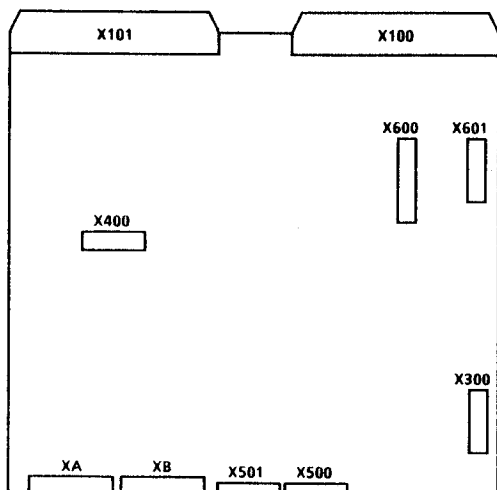

PC board C98043-A1601 (converters 30 to 600A)

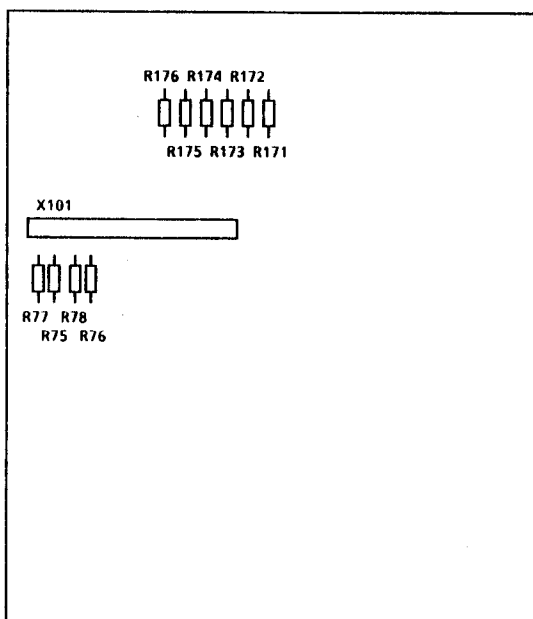

Shunt resistors for the field circuit:  
R175 and R176 are directly soldered onto the PC board, R171 to R174 are mounted on solder pins, and can be removed for the required field current reduction.

Load resistors for the armature circuit:  
R75 to R78 are mounted on solder pins, and can be removed if the armature current is to be reduced, according to the table.



**WARNING**

Load resistors for the armature circuit, R75 and R76 and R77 and R78 must only be removed in pairs.

PC board C98043-A1602 (converters 640 to 1200A)

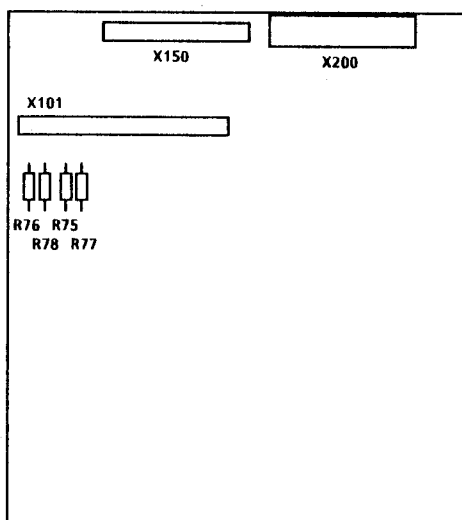

Load resistors for the armature circuit:  
R75 to R78 are mounted on solder pins, and can be removed if the armature current is to be reduced, according to the table.



**WARNING**

The load resistors for the armature circuit, R75 and R76 and R77 and R78 must only be removed in pairs.

PC board C98043-A1603 (converters 640 to 1200A)

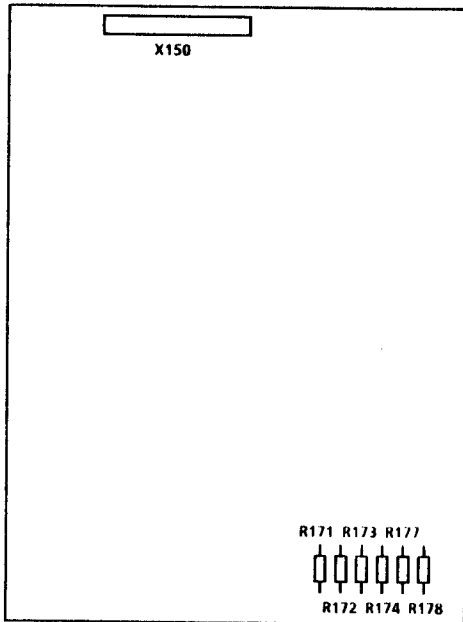

Shunt resistors for the field circuit:  
R171 to R174 and R177 and R178 are soldered directly onto the PC board.

PC board C98043-A1607 (converters 15A)

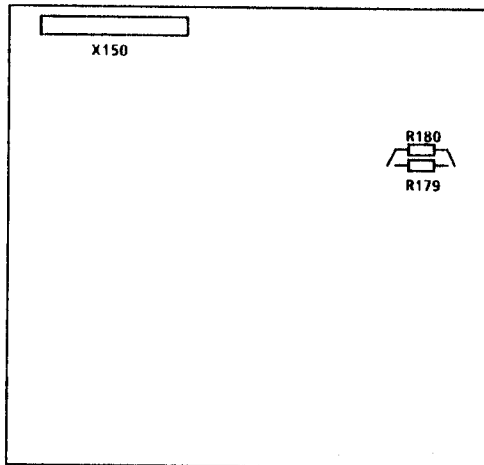

Shunt resistors for the field circuit:  
R179 is soldered directly onto the PC board,  
R180 is mounted on solder pins.

PC board C98043-A1608 (converters 15A)

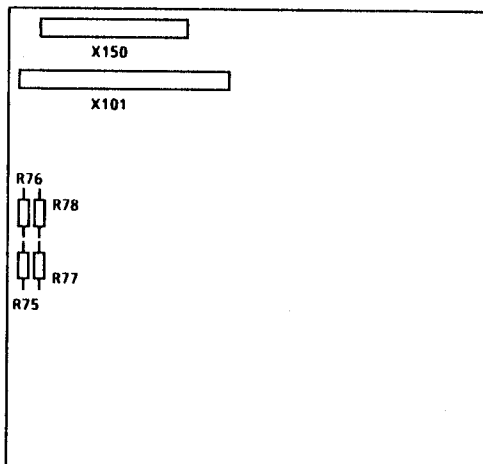

Load resistors for the armature circuit:  
R75 to R78 are mounted on solder pins, and can be removed if the armature current is to be reduced, according to the table.



**WARNING**

The load resistors for the armature circuit, R75 and R76, and R77 and R78 must only be removed in pairs.

## 6.7 Fuses and commutating reactors

### 6.7.1 Commutating reactors

Commutating reactors should be taken from Catalog DA93.1.

### 6.7.2 Fuses

| Converter<br>Ord. No. | Type designation           | Line fuse |                          |
|-----------------------|----------------------------|-----------|--------------------------|
|                       |                            | Ord. No.  | Rated<br>DC current<br>A |
| 6RA2418 - 6DS22       | D485 / 30 Mre - GeE6S22    | 3NE8003   | 35                       |
| 6RA2425 - 6DS22       | D485 / 60 Mre - GeE6S22    | 3NE8020   | 80                       |
| 6RA2428 - 6DS22       | D485 / 90 Mre - GeE6S22    | 3NE8022   | 125                      |
| 6RA2431 - 6DS22       | D485 / 125 Mre - GeE6S22   | 3NE8024   | 160                      |
| 6RA2475 - 6DS22       | D485 / 200 Mre - GeEF6S22  | 3NE3225   | 200                      |
| 6RA2477 - 6DS22       | D485 / 250 Mre - GeEF6S22  | 3NE3227   | 250                      |
| 6RA2481 - 6DS22       | D485 / 400 Mre - GeEF6S22  | 3NE3233   | 450                      |
| 6RA2485 - 6DS22       | D485 / 600 Mre - GeEF6S22  | 3NE3336   | 630                      |
| 6RA2487 - 4DS2.       | D485 / 850 Mre - GeEF4S2.  | *)        |                          |
| 6RA2491 - 4DS2.       | D485 / 1200 Mre - GeEF4S2. | *)        |                          |
| 6RA2418 - 6GS22       | D600 / 30 Mre - GeE6S22    | 3NE8003   | 35                       |
| 6RA2425 - 6GS22       | D600 / 60 Mre - GeE6S22    | 3NE8020   | 80                       |
| 6RA2428 - 6GS22       | D600 / 90 Mre - GeE6S22    | 3NE8022   | 125                      |
| 6RA2431 - 6GS22       | D600 / 125 Mre - GeE6S22   | 3NE8024   | 160                      |
| 6RA2475 - 6GS22       | D600 / 200 Mre - GeEF6S22  | 3NE3225   | 200                      |
| 6RA2477 - 6GS22       | D600 / 250 Mre - GeEF6S22  | 3NE3227   | 250                      |
| 6RA2481 - 6GS22       | D600 / 400 Mre - GeEF6S22  | 3NE3233   | 450                      |
| 6RA2485 - 6GS22       | D600 / 600 Mre - GeEF6S22  | 3NE3336   | 630                      |
| 6RA2487 - 4GS2.       | D600 / 850 Mre - GeEF4S2.  | *)        |                          |
| 6RA2491 - 4GS2.       | D600 / 1200 Mre - GeEF4S2. | *)        |                          |
| 6RA2485 - 4KS2.       | D900 / 640 Mre - GeEF4S2.  | *)        |                          |
| 6RA2487 - 4KS2.       | D900 / 860 Mre - GeEF4S2.  | *)        |                          |

\*) Branch fuses are included in the converter and external semiconductor fuses are not necessary.

| Converter<br>Order No. | Type designation           | Phase fuse |                          | DC fuse   |                          |
|------------------------|----------------------------|------------|--------------------------|-----------|--------------------------|
|                        |                            | Order No.  | Rated<br>DC-current<br>A | Order No. | Rated<br>DC-current<br>A |
| 6RA2413 - 6DV62        | D420/ 15Mreq - GeG0V62     | 3NE8015    | 25                       | 3NE8015   | 25                       |
|                        |                            | 5SD440     | 25                       | 5SD440    | 25                       |
| 6RA2418 - 6DV62        | D420/ 30 Mreq - GeG6V62    | 3NE8003    | 35                       | 3NE4102   | 40                       |
| 6RA2425 - 6DV62        | D420/ 60 Mreq - GeG6V62    | 3NE8020    | 80                       | 3NE4121   | 100                      |
| 6RA2430 - 6DV62        | D420/ 100 Mreq - GeG6V62   | 3NE8022    | 125                      | 3NE4124   | 160                      |
| 6RA2432 - 6DV62        | D420/ 140 Mreq - GeG6V62   | 3NE8024    | 160                      | 3NE3224   | 160                      |
| 6RA2475 - 6DV62        | D420/ 200 Mreq - GeGF6V62  | 3NE3225    | 200                      | 3NE3227   | 250                      |
| 6RA2477 - 6DV62        | D420/ 250 Mreq - GeGF6V62  | 3NE3227    | 250                      | 3NE3227   | 250                      |
| 6RA2481 - 6DV62        | D420/ 400 Mreq - GeGF6V62  | 3NE3233    | 450                      | 3NE3233   | 450                      |
| 6RA2485 - 6DV62        | D420/ 600 Mreq - GeGF6V62  | 3NE3336    | 630                      | 3NE3336   | 630                      |
| 6RA2487 - 4DV6.        | D420/ 850 Mreq - GeGF4V6.  | *)         |                          |           |                          |
| 6RA2491 - 4DV6.        | D420/ 1200 Mreq - GeGF4V6. | *)         |                          |           |                          |
| 6RA2418 - 6GV62        | D520/ 30 Mreq - GeG6V62    | 3NE8003    | 35                       | 3NE4102   | 40                       |
| 6RA2425 - 6GV62        | D520/ 60 Mreq - GeG6V62    | 3NE8020    | 80                       | 3NE4121   | 100                      |
| 6RA2430 - 6GV62        | D520/ 100 Mreq - GeG6V62   | 3NE8022    | 125                      | 3NE4124   | 160                      |
| 6RA2432 - 6GV62        | D520/ 140 Mreq - GeG6V62   | 3NE8024    | 160                      | 3NE3224   | 160                      |
| 6RA2475 - 6GV62        | D520/ 200 Mreq - GeGF6V62  | 3NE3225    | 200                      | 3NE3227   | 250                      |
| 6RA2477 - 6GV62        | D520/ 250 Mreq - GeGF6V62  | 3NE3227    | 250                      | 3NE3227   | 250                      |
| 6RA2481 - 6GV62        | D520/ 400 Mreq - GeGF6V62  | 3NE3233    | 450                      | 3NE3233   | 450                      |
| 6RA2485 - 6GV62        | D520/ 600 Mreq - GeGF6V62  | 3NE3336    | 630                      | 3NE3336   | 630                      |
| 6RA2487 - 4GV6.        | D520/ 850 Mreq - GeGF4V6.  | *)         |                          |           |                          |
| 6RA2491 - 4GV6.        | D520/ 1200 Mreq - GeGF4V6. | *)         |                          |           |                          |
| 6RA2485 - 4KV6.        | D790/ 640 Mreq - GeGF4V6.  | *)         |                          |           |                          |
| 6RA2487 - 4KV6.        | D790/ 860 Mreq - GeGF4V6.  | *)         |                          |           |                          |

\*) Branch fuses are included in the converter and external semiconductor fuses are not necessary.

### Recommended field fuses

| Converter<br>rated DC current<br>A | Max. permissible<br>field current<br>A | Fuse<br>Order No. | Rated DC current<br>of the fuse<br>A |
|------------------------------------|--|-------------------|--------------------------------------|
| 15                                 | 2,5                                    | 5SD420            | 16                                   |
| 30                                 | 5                                      | 5SD420            | 16                                   |
| 60 to 140                          | 10                                     | 5SD420            | 16                                   |
| 200 to 250                         | 15                                     | 5SD440            | 25                                   |
| 400 to 600                         | 25                                     | 5SD440            | 25                                   |
| 640 to 1200                        | 30                                     | 5SD480            | 30                                   |

6.8 Terminal connecting diagram (for 15A converters)

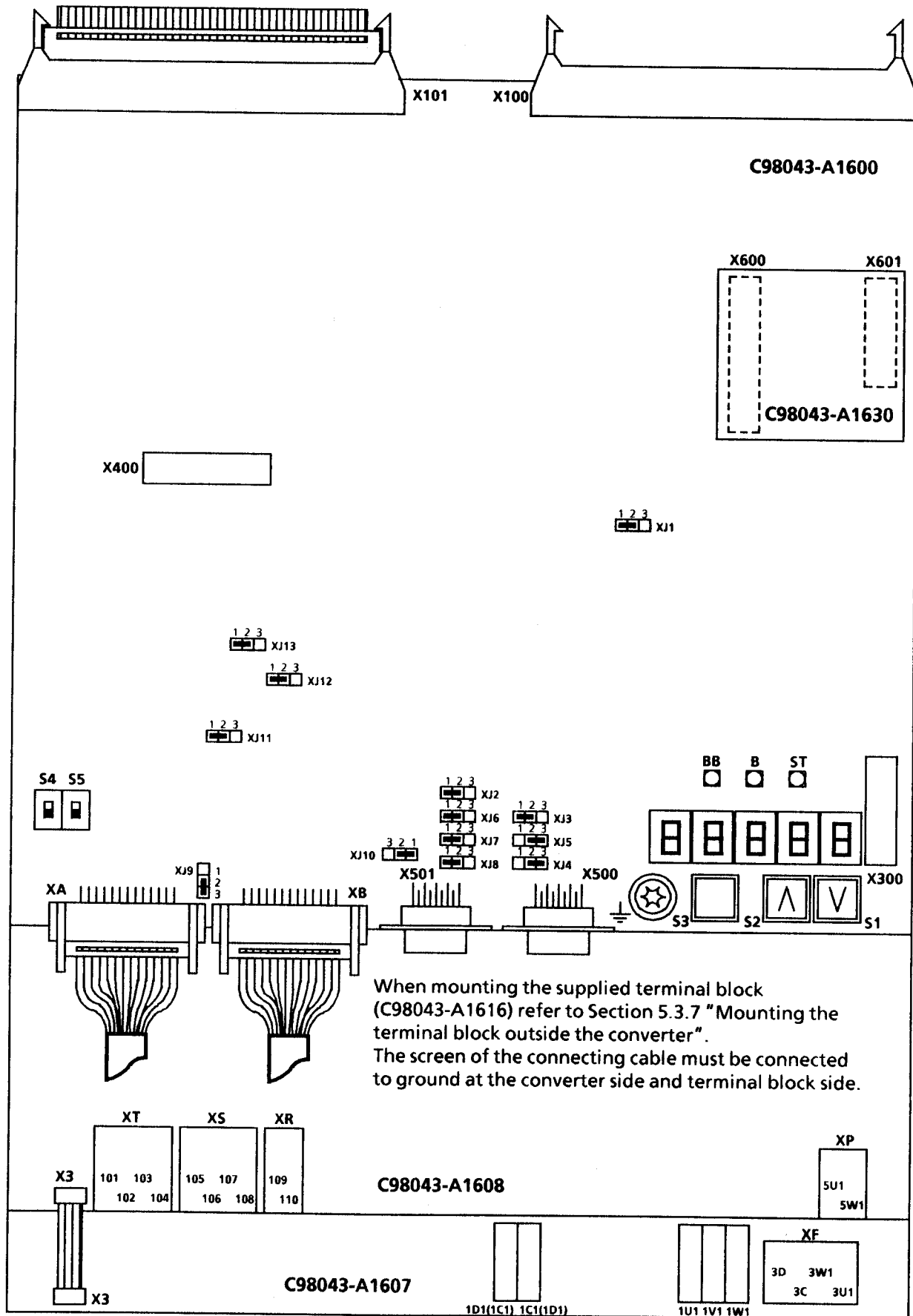

Terminal connecting diagram (for 30A to 600A converters)

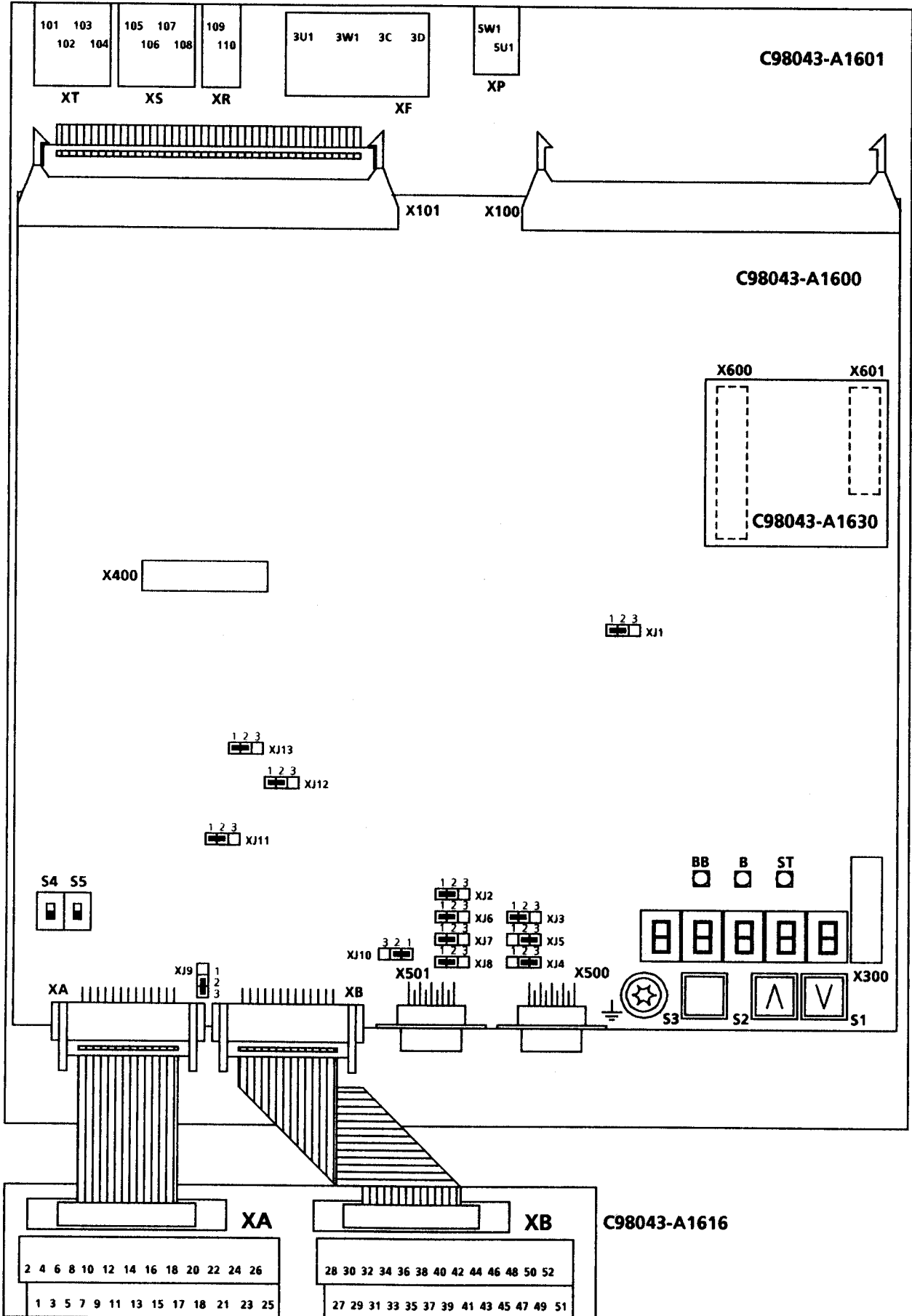

Terminal connecting diagram (for 640A to 1200A converters)

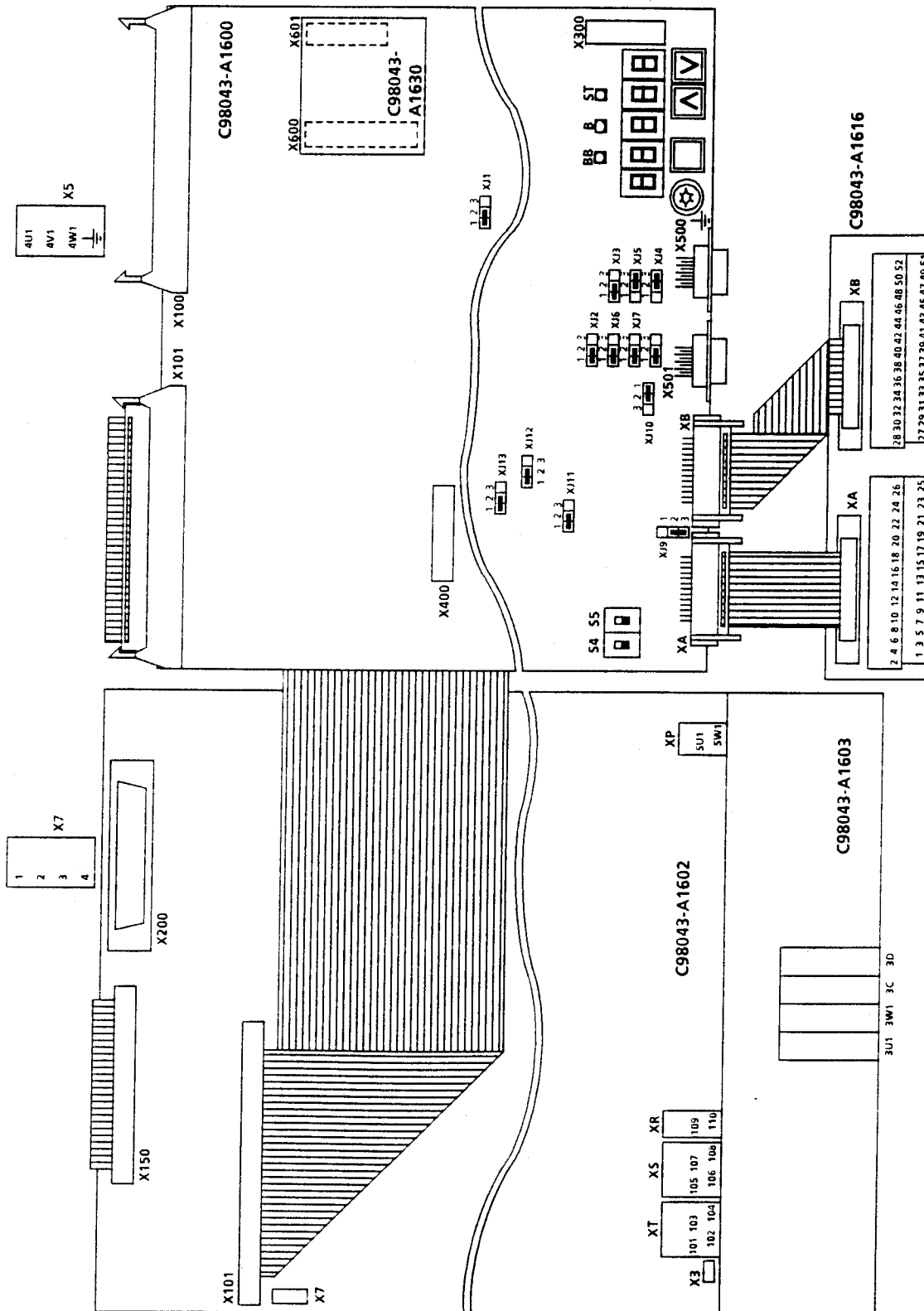

## 6.8.1 Settings

**CAUTION**

The plug-in jumpers and switch may only be changed if the electronics power supply is switched-off!

### Electronics PC board, C98043-A1600

Pin 1 of the plug-in jumpers is labelled.

|                     |   |
|---------------------|---|
| Plug-in jumper XJ1  | Write signal for the EEPROM interrupted (hardware write protection)<br>Position 1-2: Write active (as supplied)<br>Position 2-3: Write de-activated   |
| Plug-in jumper XJ2  | 5V power supply for the interface expansion option (C98043-A1618)<br>Position 1-2: Interface is not supplied (as supplied)<br>Position 2-3: Interface is supplied                                   |
| Plug-in jumper XJ3  | RS485 bus termination<br>Position 1-2: No bus termination (as supplied)<br>Position 2-3: Bus is terminated (X500.3 and X500.8 connected through a 150Ω resistor)                                    |
| Plug-in jumper XJ4  | RS485 bus termination<br>Position 1-2: Bus (X500.8) is terminated after M5 (X500.5) (390Ω)<br>Position 2-3: No bus termination (as supplied)  |
| Plug-in jumper XJ5  | RS485 bus termination<br>Position 1-2: Bus (X500.3) is terminated after P5 (X500.6) (390Ω)<br>Position 2-3: No bus termination (as supplied)  |
| Plug-in jumper XJ6  | Transmit signal for the interface expansion option (C98043-A1618)<br>Position 1-2: Signal is not fed to connector X501 (as supplied)<br>Position 2-3: Signal is fed to connector X501               |
| Plug-in jumper XJ7  | Receive signal for the interface expansion option (C98043-A1618)<br>Position 1-2: Signal is not fed to connector X501 (as supplied)<br>Position 2-3: Signal is fed to connector X501                |
| Plug-in jumper XJ8  | Control signal (driver enable) for interface expansion option (C98043-A1618)<br>Position 1-2: Signal is not fed to connector X501 (as supplied)<br>Position 2-3: Signal is fed to connector X501    |
| Plug-in jumper XJ9  | Ground M5/2 for binary inputs connected with internal ground M<br>Position 1-2: Not connected<br>Position 2-3: Connected (as supplied)  |
| Plug-in jumper XJ10 | 24V power supply for binary outputs<br>Position 1-2: Supply with internal P24 (as supplied)<br>Position 2-3: Supply with external P24 via terminal XB-49 w.r.t. M (ground terminals XB-47 or XB-51) |
| Plug-in jumper XJ11 | Pulse encoder, track 1, level changeover<br>Position 1-2: 15V rated voltage (as supplied)<br>Position 2-3: 5V rated voltage   |
| Plug-in jumper XJ12 | Pulse encoder, track 2, level changeover<br>Position 1-2: 15V rated voltage (as supplied)<br>Position 2-3: 5V rated voltage   |



|                     |  |
|---------------------|--|
| Plug-in jumper XJ13 | Pulse encoder 0 mark, level changeover<br>Position 1-2: 15V rated voltage (as supplied)<br>Position 2-3: 5V rated voltage  |
| Pushbutton S1       | LOWER parameter  |
| Pushbutton S2       | RAISE parameter  |
| Pushbutton S3       | Parameter mode changeover  |
| Switch S4           | Main setpoint (terminal XA-4, XA-5)<br>Position 1: 0... ± 10V (as supplied)<br>Position 2: 0... 20mA   |
| Switch S5           | Analog select input 1 WEA1 (terminal XA-6, XA-7)<br>Position 1: 0... ± 10V (as supplied)<br>Position 2: 0... 20mA  |
| R135, R136 and R138 | 0Ω resistors, connection M-ground<br>When supplied, M and M5 are connected to ground. These resistors are only removed to prevent disturbances as a result of ground loops, i.e. if the electronics ground is connected to ground in a different fashion (e.g. through signal cables).<br>Example: Signal ground grounded at the NC control and connected with signal terminals on the converter |

### Motor interface PC board C98043-A1617 (option)

Pin 1 of the plug-in jumpers is labelled.

|                      |   |
|----------------------|---|
| Plug-in jumper XJ100 | Connects ground M5/3 for the binary inputs of the motor sensor system with internal ground M5<br>Position 1-2: Connection closed (as supplied)<br>Position 2-3: Connection open |
| Plug-in jumper XJ101 | Pre-setting for the motor temperature sensor type<br>Position 1-2: KTY84 or PTC (as supplied)<br>Position 2-3: PT100  |

### Interface expansion PC board C98043-A1618 (option)

Pin 1 of the plug-in jumpers is labelled.

|                      |  |
|----------------------|--|
| Plug-in jumper XJ200 | RS485 bus termination<br>Position 1-2: Bus (X502.8) is terminated (390Ω) after M5 (X502.5)<br>Position 2-3: No bus termination (as supplied)                       |
| Plug-in jumper XJ201 | RS485 bus termination<br>Position 1-2: No bus termination (as supplied)<br>Position 2-3: Bus is terminated (X502.3 is connected to X502.8 through a 150Ω resistor) |
| Plug-in jumper XJ202 | RS485 bus termination<br>Position 1-2: Bus (X502.3) is terminated (390Ω) after P5 (X502.6)<br>Position 2-3: No bus termination (as supplied)                       |

## 6.9 Terminal assignment



**WARNING**

The converter could be damaged or destroyed if connected incorrectly.

### Power section

#### Terminal type:

|                          |   |
|--------------------------|---|
| 15A converters           | PC board terminal (4mm <sup>2</sup> cross-section, finely-stranded wire)  |
| 30A converters           | Screw terminal ( 10 mm <sup>2</sup> cross-section, finely-stranded wire)  |
| 60A converters           | Screw terminal ( 16 mm <sup>2</sup> cross-section, finely-stranded wire)  |
| 90A to 250A converters   | 1U1,1V1,1W1: M8 nut (3x20 copper bus)<br>1C1,1D1: M10 nut (4x25 copper bus)   |
| 400A converter           | 1U1,1V1,1W1: M10 nut (3x30 copper bus)<br>1C1,1D1: M10 nut (3x40 copper bus)  |
| 600A converter           | 1U1,1V1,1W1: M10 nut (5x30 copper bus)<br>1C1,1D1: M10 nut (5x40 copper bus)  |
| 640A to 1200A converters | The power connections are at the rear of the SIMOREG converter (refer to dimension drawing).<br>When mounted in a cubicle, these terminals are only accessible if the cubicle has a rear door. Front-sided connection is possible with a connecting element set (6QX5374). The connecting cables for the DC and AC sides should be selected according to DIN VDE 0298. Cable lugs should be used to connect cables. They should be bolted to the converter buses without any washers or spring washers. |

| Function                          | Terminal  | Connected values/comments              | Possible settings    |
|-----------------------------------|---|--|----------------------|
| Armature supply input             | 1U1<br>1V1<br>1W1   | } Refer to technical data, Section 3.4 | P071                 |
| Protective conductor PE           |  |  |                      |
| Armature circuit-motor connection | 1C1 (1D1)<br>1D1 (1C1)  |  | P072<br>P100<br>P101 |

### Field circuit

#### Terminal type:

|                          |   |
|--------------------------|---|
| 15A Gerät                | PC board terminal, 2,5mm <sup>2</sup> cross-section, finely-stranded wire           |
| 30A to 600A converters   | G5/4 converter terminal (screw terminal)<br>maximum cross-section, 4mm <sup>2</sup> |
| 640A to 1200A converters | maximum cross-section, 10mm <sup>2</sup>  |

| Function          | Terminal XF | Connected values/comments    | Possible settings |
|-------------------|-------------|------------------------------|-------------------|
| Supply connection | 3U1<br>3W1  | 2-ph. AC 400 ( + 15% / -20%) | P102              |
| Field connection  | 3C<br>3D    | Rated DC voltage 325V        |                   |

### Electronics power supply

Terminal type: MSTB2.5 plug-in terminals  
maximum cross-section, 1.5mm<sup>2</sup>

| Function | Terminal XP | Connected values/comments  |
|----------|-------------|--|
| Supply   | 5U1<br>5W1  | 2-ph. AC 400 (+ 15% / -25%); I <sub>n</sub> = 0.5A<br>(- 35% for 1min) |

#### NOTE

For converters with a power section supply voltage, which lies outside the tolerance range (max. permissible power section supply voltage, refer to Section 3.4!), the supplies for the electronics, field and the fan must be reduced to 400 V AC through a transformer.

An autotransformer is recommended for power section supply voltages up to 500 V. An isolating transformer must be used for power section supply voltages exceeding 500 V. This isolating transformer should have a center tap, which is connected with protective ground PE.

Refer to the 6QG35 Instruction Manual, under the section power supply, for the procedure with a parallel SITOR set and nominal power section supply voltage  $\geq 500$  V.

The nominal value of the power section supply voltage is set in parameter P071.

### Fans (for force-cooled converters $\geq 200$ A)

Terminal type: G5/4 converter terminal (screw terminal)  
maximum cross-section, 4mm<sup>2</sup>

| Function                | Terminal  | Connected values/comments   |
|-------------------------|---|---|
| Supply                  | 4U1<br>4V1<br>4W1   | for converters 200A to 600A:<br>3-ph. AC 400 ( $\pm 15\%$ ); 0,24A; 95W<br>for converters > 600A: |
| Protective conductor PE |  | 3-ph. AC 400 ( $\pm 15\%$ ); 2x0,27A;<br>2x120W (refer to Section 3.4)                            |



#### WARNING



The converter might overheat if the incorrect phase sequence is connected (incorrect fan direction of rotation)

Test: Optically check whether the fan is rotating in the direction indicated by the arrow!

Caution: You can be injured by rotating components!

### Open-loop and closed-loop control section

**Terminal type:** MKKDS1,5 double-tier PC board terminal (screw terminal)  
or MSTB2.5 plug-in terminal  
maximum cross-section, 1.5mm<sup>2</sup>

#### Analog inputs - setpoint inputs, reference voltage

| Function   |                                    | Terminal<br>XA,XB | Connected values/comments  | Possible<br>settings   |  |
|--|------------------------------------|-------------------|--|--|--|
| Reference  | M<br>P10<br>N10                    | 1<br>2<br>3       | } $\pm 0.5\%$ at 25°C (stability 0.1%<br>per 10°K); 10mA short-circuit proof   |  |  |
| Select input   | main setpoint +<br>main setpoint - | 4<br>5            |  | Differential input<br>S4 - position 1: $\pm 10V$ ; 515k $\Omega$<br>Resolution: approx. 0.6mV<br>S4 - position 2: 0 - 20mA; 300 $\Omega$<br>4 - 20mA; 300 $\Omega$<br>(polarity reversal via<br>the binary select input)<br>Common mode suppression: $\pm 15V$ | S4<br>P700<br>P701<br>P702<br>P703<br>P704 |
| Caution:<br>Terminal 4 and 5 must be<br>connected when using this select<br>input! |                                    |                   |  |  |  |
| Select input   | analog 1 +<br>analog 1 -           | 6<br>7            | Differential input<br>S5 - position 1: $\pm 10V$ ; 515k $\Omega$<br>Resolution: approx. 0.6mV<br>S5 - position 2: 0 - 20mA; 300 $\Omega$<br>4 - 20mA; 300 $\Omega$<br>(polarity reversal via<br>the binary select input)<br>Common mode suppression: $\pm 15V$ | S5<br>P710<br>P711<br>P712<br>P713<br>P714   |  |
| Caution:<br>Terminal 6 and 7 must be<br>connected using this select input!         |                                    |                   |  |  |  |
| Select input   | analog 2                           | 8                 | $\pm 10V$ ; 52k $\Omega$   | P716   |  |
| Analog ground  |                                    | 9                 | Resolution: approx. 10.8mV   | P717<br>P718<br>P719   |  |
| Select input   | analog 3                           | 10                | $\pm 10V$ ; 52k $\Omega$   | P721   |  |
| Analog ground  |                                    | 11                | Resolution: approx. 10.8mV   | P722<br>P723<br>P724   |  |

#### Analog inputs - speed actual value inputs, tachometer inputs

| Function          |             | Terminal<br>XT | Connected values/comments  | Possible<br>settings |
|-------------------|-------------|----------------|----------------------------|----------------------|
| Tachometer        | 80V to 250V | 101            | $\pm 250V$ ; 438k $\Omega$ | P083                 |
| connection        | 25V to 80V  | 102            | $\pm 80V$ ; 138k $\Omega$  | P706                 |
|                   | 8V to 25V   | 103            | $\pm 25V$ ; 44k $\Omega$   | P707                 |
| Tachometer ground |             | 104            |                            | P708<br>P709         |

## Pulse encoder input

| Function                   | Terminal<br>XA,XB | Connected values/comments  | Possible<br>settings |
|----------------------------|-------------------|--|----------------------|
| Supply (+ 13V to + 18V)    | 26                | 200mA; short-circuit proof via PTC   |                      |
| Ground, pulse encoder M5/1 | 27                |  |                      |
| Track 1 Positive supply    | 28                | Load: $\leq 5\text{mA}$ at 15V<br>(w/o switching losses, refer below<br>Cable, cable length, screen connection                           | XJ11                 |
| Track 1 Negative supply    | 29                |  | XJ12                 |
| Track 2 Positive supply    | 30                | Switching hysteresis refer below<br>Mark-to-space ratio: 1:1   | XJ13                 |
| Track 2 Negative supply    | 31                |  | P083                 |
| Nullmarke                  | Positive supply   | Input pulse level: refer below<br>Track offset: Table 1, ref. below<br>Pulse frequency: Table 2, ref. below<br>Cable length: refer below | P140                 |
|                            | Negative supply   |  | P141                 |
|                            |                   |  | P142                 |
|                            |                   |  | P143                 |

## Characteristic values of the pulse encoder evaluation electronics

## Input pulse level:

Encoder signals (symmetrical and unsymmetrical) up to a max. 27 V differential voltage can be processed by the evaluation electronics. The evaluation electronics must adapt the encoder signal voltage via plug-in jumpers XJ11, XJ12 and XJ13. Two rated voltage ranges are defined using the plug-in jumper setting:

- **5V** nominal voltage range with plug-in jumpers XJ11, XJ12 and XJ13 in position 2-3:
  - Low level: Differential voltage  $< 0.8\text{V}$
  - High level: Differential voltage  $> 2.0\text{V}$
  - Hysteresis:  $> 0.2\text{V}$
  - Common-mode control range:  $\pm 10\text{V}$
- **15V** nominal voltage range with plug-in jumpers XJ11, XJ12 and XJ13 in position 1-2:
  - Low level: Differential voltage  $< 5.0\text{V}$
  - High level: Differential voltage  $> 8.0\text{V}$  Restriction: refer to the switching frequency
  - Hysteresis:  $> 1\text{V}$
  - Common-mode control range:  $\pm 10\text{V}$

If the pulse encoder does not provide symmetrical signals, then its ground should be fed as twisted pair in each signal cable, and should be connected with the negative connections of track 1, track 2 and the zero mark.

## Switching frequency:

The maximum encoder pulse frequency is 300 kHz. In this case, in order that the encoder pulses are correctly evaluated, the minimum distance  $T_{\min}$  between two encoder signal edges (track 1, track 2), specified in the table, should be maintained.

Table 1:

|                                    | 5V rated input voltage |                 | 15V rated input voltage |       |                |
|------------------------------------|------------------------|-----------------|-------------------------|-------|----------------|
|                                    | 2V                     | $> 2.5\text{V}$ | 8V                      | 10V   | $> 14\text{V}$ |
| Differential voltage <sup>1)</sup> |                        |                 |                         |       |                |
| $T_{\min}$ <sup>2)</sup>           | 630ns                  | 380ns           | 630ns                   | 430ns | 380ns          |

- 1) Differential voltage at the terminals of the evaluation electronics
- 2) The phase error  $L_G$  (deviating from  $90^\circ$ ), which can occur due to the encoder and cable, can be calculated from  $T_{\min}$ :

$$L_G = \pm (90^\circ - f_p \times T_{\min} \times 360^\circ \times 10^{-6})$$

$L_G$  [°] = Phase error

$f_p$  [kHz] = Pulse frequency

$T_{\min}$  [ns] = Minimum distance between edges

This formula is only valid if the mark-to-space ratio of the encoder signals is 1:1.

If the pulse encoder is incorrectly matched to the encoder cable, disturbing cable reflections are created on the receive side. These reflections must be damped so that the encoder pulses can be correctly evaluated. The following limit values, listed in the table must be maintained, in order that the resulting power loss in the adaption element of the evaluation electronics is not exceeded.

Table 2:

| $f_{\max}$                         | 50kHz  | 100kHz | 150kHz | 200kHz | 300kHz |
|------------------------------------|--------|--------|--------|--------|--------|
| Differential voltage <sup>3)</sup> | to 27V | to 22V | to 18V | to 16V | to 14V |

- 3) Differential voltage of the encoder pulses at no load  
(approximate encoder power supply voltage)

#### Cable, cable length, screen connection:

The encoder cable capacitance must be recharged at each encoder edge change. The RMS value of this current is proportional to the cable length and the pulse frequency, and must not exceed the current specified by the encoder manufacturer. A suitable cable, recommended by the encoder manufacturer should be used, and the maximum cable length should not be exceeded. Generally, a twisted cable pair with common pair screening is sufficient for each track. Crosstalk between the cables is thus reduced. The screening of all pairs protects against noise pulses. The screen should be connected to the screen bar of the SIMOREG converter with the largest possible surface area. When using the external terminal block, the tachometer cable screen must be connected where it enters the cubicle. Optional screened cables should be used between the SIMOREG converter and terminal block (Order No.: 6RX1240-0AM70).

#### Analog inputs - others

| Function               | Terminal<br>XA,XB | Connected values/comments | Possible<br>settings |
|------------------------|-------------------|---------------------------|----------------------|
| Reserved for use later | 22                |                           |                      |
| Reserved for use later | 23                |                           |                      |
| Ground, analog M       | 24                |                           |                      |
| Ground, analog M       | 25                |                           |                      |

#### Analog outputs

| Function                                    | Terminal<br>XA,XB | Connected values/comments   | Possible<br>settings                 |
|---|-------------------|---|--------------------------------------|
| Current act. value<br>Ground, analog M      | 12<br>13          | 0... ± 10V corresponds to 0... ± 200%<br>rated converter DC current<br>max. load 2mA, short-circuit proof | P739                                 |
| Select output, analog 1<br>Ground, analog M | 14<br>15          | 0... ± 10V, max. 2mA<br>short-circuit proof<br>resolution ± 11bit   | P740<br>P741<br>P742<br>P743<br>P744 |
| Select output, analog 2<br>Ground, analog M | 16<br>17          | 0... ± 10V, max. 2mA<br>short-circuit proof<br>resolution ± 11bit   | P745<br>P746<br>P747<br>P748<br>P749 |

## Analog outputs

| Function                                   | Terminal<br>XA,XB | Connected values/comments   | Possible<br>settings                 |
|--|-------------------|---|--------------------------------------|
| Select output analog 3<br>Ground, analog M | 18<br>19          | 0... ± 10V, max. 2mA<br>short-circuit proof<br>resolution ± 11bit | P750<br>P751<br>P752<br>P753<br>P754 |
| Select output analog 4<br>Ground, analog M | 20<br>21          | 0... ± 10V, max. 2mA<br>short-circuit proof<br>resolution ± 11bit | P755<br>P756<br>P757<br>P758<br>P759 |

## Binary control inputs



**WARNING**

Potential isolation < 50V with respect to PE via optocoupler, if M5/2 is disconnected from the internal ground. Plug-in jumper XJ9 in position 1-2.

| Function   | Terminal<br>XA,XB | Connected values/comments   | Possible<br>settings |
|--|-------------------|---|----------------------|
| Supply   | 34<br>44          | 24V DC, max. load 100mA, internal supply referred to internal ground, effective if ground M5/2 is connected with internal ground (XJ9 in position 2-3)  |                      |
| Ground M5/2 for binary inputs<br>for binary inputs | 35<br>45          | } can be disconnected from int. ground (disconnected ⇒ XJ9 in position 1-2)   | XJ9<br>XJ9           |
| Switch-on / shutdown                               | 37                | H signal: Switch-on 4)<br>Line contactor ON + (H signal at terminal 38) accelerate along the ramp-function generator ramp up to operating speed.<br><br>L signal: Shutdown 4)<br>Decelerate along the ramp-down function generator ramp up to $n < n_{min}$ (P370) + controller inhibit + line contactor OFF. |                      |
| Enable signal                                      | 38                | H signal: Controller enabled 4)<br><br>L signal: Controller inhibited 4)<br>The L signal acts as higher-level signal on "inching" and "crawl". (precise function description, refer to Section 10.3 "binary input functions").  |                      |

- 4) H signal: + 13V to + 33V  
L signal: - 3V to + 5V or terminal open } for binary control inputs  
8.5mA at 24V

## Binary control inputs

| Function  | Terminal<br>XA,XB | Connected values/comments   | Possible<br>settings |
|---|-------------------|---|----------------------|
| Select input      binary 1                      | 39                | refer to Section 10.3<br>"binary input functions" 4)  | P761                 |
| Select input      binary 2                      | 40                | refer to Section 10.3<br>"binary input functions" 4)  | P762                 |
| Select input      binary 3                      | 41                | refer to Section 10.3<br>"binary input functions" 4)  | P763                 |
| Select input      binary 4                      | 42                | refer to Section 10.3<br>"binary input functions" 4)  | P764                 |
| Select input      binary 5                      | 43                | refer to Section 10.3<br>"binary input functions" 4)  | P765                 |
| Select input      binary 6<br>fault acknowledge | 36                | The group signal is acknowledged with a positive edge. The converter is in the "fault" condition until the fault has been removed and acknowledged, and then the converter goes into the "switch-on inhibit" condition. The "switch-on inhibit" condition is cancelled by applying an L signal to terminal 37. 4) | P766                 |

## Safety shutdown (E-Stop, also refer to Section 10.3.93)

| Function                        | Terminal<br>XS | Connected values/comments                              | Possible<br>settings |
|---------------------------------|----------------|--|----------------------|
| Supply for<br>safety shutdown   | 106            | 24V DC, max. load 50mA,<br>short-circuit proof via PTC |                      |
| Safety shutdown      switch     | 105            | $I_e = 20\text{mA}$                                    |                      |
| Safety shutdown      pushbutton | 107            | NC contact $I_e = 30\text{mA}$                         |                      |
| Safety shutdown      reset      | 108            | NO contact $I_e = 10\text{mA}$                         |                      |

**NOTE**

Either terminal 105 or terminals 107 + 108 can be used!  
When supplied, terminal 105 is connected to terminal 106.

- |   |   |
|---|---|
| 4) H signal: + 13V to + 33V             | } for binary control inputs<br>8.5mA at 24V |
| L signal: - 3V to + 5V or terminal open |   |



## Binary control outputs

| Function   | Terminal<br>XA, XB, XR | Connected value/comments  | Possible<br>settings |
|--|------------------------|---|----------------------|
| External supply for<br>binary select output                              | 49                     | 24V DC supply (20V - 30V)<br>(plug-in jumper XJ10, position 2-3) 5)                                 | XJ10                 |
| Ground M   | 47                     |   |                      |
| binary select output<br>binary select output                             | 51                     |   |                      |
| Select output "fault"  | 46                     | H signal: no fault 5) 6)<br>L signal: fault 5) 6)   | P771                 |
| Select output binary 2   | 48                     | refer to Section 10.4<br>"binary output functions" 5) 6)  | P772                 |
| Select output binary 3   | 50                     | refer to Section 10.4<br>"binary output functions" 5) 6)  | P773                 |
| Select output binary 4   | 52                     | refer to Section 10.4<br>"binary output functions" 5) 6)  | P774                 |
| Relay for line contactor, common<br>Relay for line contactor, NO contact | 109<br>110             | Contact loading capability:<br>≤ 250V AC, 4A; cosΦ = 1<br>≤ 250V AC, 2A; cosΦ = 0.4<br>≤ 30V DC, 2A |                      |

RS232 serial interface (9-pin SUBMIN D socket connector)  
(G-SST1)

Use a screened cable! Ground screen at both ends!

| Function                      | Con. pin | Connected value/comments                               | Possible<br>settings     |
|-------------------------------|----------|--|--------------------------|
| RxD1_1 if XJ7 in position 2-3 | X501.1   | Connection to interface expansion<br>option            | P790<br>bis<br>P798      |
| Received data RxD             | X501.2   | RS232 interface  |                          |
| Transmitted data TxD          | X501.3   | RS232 interface  |                          |
| TxD1_1 if XJ6 in position 2-3 | X501.4   | Connection to interface expansion<br>option            | XJ2<br>XJ6<br>XJ7<br>XJ8 |
| Signal ground                 | X501.5   | Ground for RS232 interface                             |                          |
| DE2_1 if XJ8 in position 2-3  | X501.6   | Direction changeover for interface<br>expansion option |                          |
| Driver output                 | X501.7   | RTS (request to send)                                  |                          |
| Driver input                  | X501.8   | CTS (clear to send)                                    |                          |
| P5_10 if XJ2 in position 2-3  | X501.9   | + 5V supply for interface expansion<br>option          |                          |

Cable length: up to 15 m according to the EIA standard RS232-C  
up to 30 m capacitive load, max. 2.5 nF (cable and receiver)

5) For an internal supply, max. load per select output: 10mA  
For an external supply, max. load per select output: 100mA

6) H signal: + 16V to + 30V  
L signal: 0V to + 2V

**RS485 serial interface (9-pin SUBMIN D socket connector)****(G-SST0)**

**Use a screened connecting cable! Ground screen at both ends!**

The bus is terminated at the end of the complete bus cable using plug-in jumpers XJ3, XJ4 and XJ5.

| Function             | Con. pin | Connected values/comments         | Possible settings |
|----------------------|----------|-----------------------------------|-------------------|
| Protective ground    | X500.1   |                                   | P780<br>to        |
| Free                 | X500.2   |                                   |                   |
| RxD_P or RxD / TxD_P | X500.3   | For four-wire and two-wire cables | P788              |
| TxD_P                | X500.4   | Only for four-wire cables         | XJ3<br>XJ4<br>XJ5 |
| DGND                 | X500.5   | Ground                            |                   |
| + 5V supply          | X500.6   | VP for cable termination          |                   |
| Free                 | X500.7   |                                   |                   |
| RxD_N or RxD / TxD_N | X500.8   | For four-wire and two-wire cables |                   |
| TxD_N                | X500.9   | Only for four-wire cables         |                   |

Cable length: For transmission speed = 187.5kBd  $\Rightarrow$  600m  
 For transmission speed  $\leq$  93.75kBd  $\Rightarrow$  1200m

The following must be observed: DIN 19245, Part 1

It is important that the potential difference between the data reference potentials DGND of all interfaces does not exceed  $\pm 7V$ . If this cannot be guaranteed, potential equalization must be provided.

Activating the RS485 and RS232 interfaces:

- Setting the baud rate using parameters P783 and P793.
- Setting the protocol (and if required, the desired function) using parameters P780 and P790.
- If either parameter P780 or P790 was set to xxx1, the required function must be selected and started with parameter P051.

**Options:****Motor interface (C98043-A1617-L1)**

Terminal type: Small MKDSN1,5 PC board terminal (screw terminal)  
max. cross-section 1.5mm<sup>2</sup> (finely-stranded wire)

| Function  | Terminal XM   | Connected value/comments                           | Possible settings  |       |
|---|---------------|--|--|-------|
| Brush length measurement supply   | 201           | + 24V DC, max. load 1)                             | P145   |       |
| Brush length  | 202           | Signal from motor, 0...17V, R <sub>e</sub> > 100kΩ |  |       |
| Ground, brush length measurement  | 203           |  |  |       |
| Motor temp. positive supply   | 204           | Sensor, P146                                       | P146   |       |
| Motor temp. negative supply   | 205           | Sensor, P146                                       | P147<br>P148   |       |
|  <b>WARNING</b><br>Binary inputs:<br>Potential isolation < 50V with respect to PE via optocoupler, if M5/3 is disconnected from the internal ground. Plug-in jumper XJ100 in position 2-3. |               |  |  |       |
| Supply  | binary inputs | 210  | 24V DC, max. load 1)<br>internal supply w.r.t. internal ground, effective if the ground M5/3 is connected to internal ground (XJ100 in position 1-2) | P145  |
| Brush length  | binary input  | 211  | } refer to parameter P145 in Section 9.2, "Parameter description"  | XJ100 |
| Bearing condition   | binary input  | 212  |  |       |
| Air flow monit.   | binary input  | 213  |  |       |
| Thermo switch   | binary input  | 214  |  |       |
| Ground M5/3   | binary inputs | 215  | can be disconnected from int. ground (disconnected ⇒ XJ100 position 2-3)   |       |

1) Total max. load at terminals 201 and 210 (+ 24V DC supply): 100mA

2) H signal: + 13V to + 33V  
L signal: - 3V to + 5V or terminal open

} for binary control inputs  
} 8.5mA at 24V

### Terminal assignment, motor interface - machine terminals

**Terminal 202:**

Analog brush length sensing  
(with potentiometer on the brushes)

- P145 = xxx0: not available  
 xxx1: } binary brush length  
 xxx2: } sensing available  
 xxx3: available  
         W02 if brush length ≤ 14mm  
         F115 if brush length ≤ 12mm

**Terminals 204 and 205:**

Analog motor temperature monitoring (with temperature sensor)

- P146 = 0: Not available  
 1: KTY84; (XJ101: 1-2);  
     W06 at T > P147; F119 at T > P148  
 2: PT100; (XJ101: 2-3);  
     W06 at T > P147; F119 at T > P148  
 3: PTC (600Ω) + W06; (XJ101: 1-2)  
 4: PTC (600Ω) + F119; (XJ101: 1-2)  
 5: PTC (1200Ω) + W06; (XJ101: 1-2)  
 6: PTC (1200Ω) + F119; (XJ101: 1-2)  
 7: PTC (1330Ω) + W06; (XJ101: 1-2)  
 8: PTC (1330Ω) + F119; (XJ101: 1-2)  
 9: PTC (2600Ω) + W06; (XJ101: 1-2)  
 10: PTC (2600Ω) + F119; (XJ101: 1-2)

**Terminal 211:**

Binary brush length sensing  
(with microswitch)

- P145 = xxx1: available + W02  
 xxx2: available + F115

**Terminal 212:**

Bearing status monitoring  
(with SPM alarm box)

- P145 = xx0x: not available  
 xx1x: available + W03  
 xx2x: available + F116

**Terminal 213:**

Motor fan monitoring  
(with vent captor, type 3201.03 air flow monitor)

- P145 = x0xx: not available  
 x1xx: available + W04  
 x2xx: available + F117

**Terminal 214:**

Binary motor temperature monitoring  
(with "thermik" bimetallic temperature monitor)

- P145 = 0xxx: not available  
 1xxx: available + W05  
 2xxx: available + F118

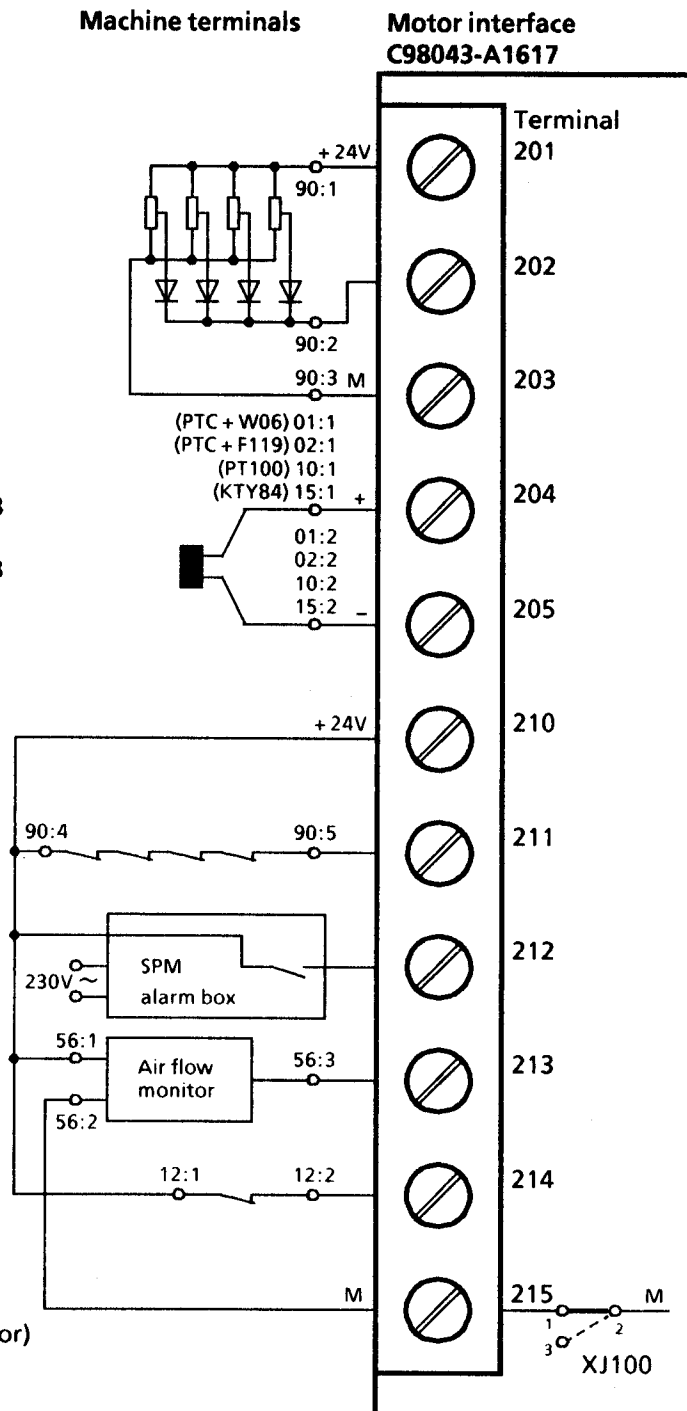

**Interface expansion (C98043-A1618-L1)**

RS485 serial interface (9-pin SUBMIN D socket connector)  
(G-SST1)

**Use a screened connecting cable! Ground screen at both ends!**

The bus is terminated at the ends of the bus cable using plug-in jumpers XJ200, XJ201 and XJ202.

| Function               | Con. pin | Connected values/comments        | Possible settings       |
|------------------------|----------|----------------------------------|-------------------------|
| Free                   | X502.1   |                                  | P790<br>to              |
| Free                   | X502.2   |                                  |                         |
| RxD_P1 or RxD / TxD_P1 | X502.3   | For four-wire or two-wire cables | P798                    |
| TxD_P1                 | X502.4   | Only for four-wire cables        | XJ200<br>XJ201<br>XJ202 |
| DGND                   | X502.5   | Ground                           |                         |
| + 5V supply            | X502.6   | VP for cable termination         |                         |
| Free                   | X502.7   |                                  |                         |
| RxD_N1 or RxD / TxD_N1 | X502.8   | For four-wire or two-wire cables |                         |
| TxD_N1                 | X502.9   | Only for four-wire cables        |                         |

Cable length: For transmission speed = 187.5kBd  $\Rightarrow$  600m  
For transmission speed  $\leq$  93.75kBd  $\Rightarrow$  1200m

The following must be observed: DIN 19245, Part 1

It is important that the potential difference between the data reference potentials DGND of all interfaces does not exceed  $\pm 7V$ . If this cannot be guaranteed, potential equalization must be provided.



## 7 Start-up

### 7.1 General safety information for start-up



#### **DANGER**



Before commissioning the converters (90A to 600 A), it must be ensured that the transparent terminal cover is located at the appropriate position on the converter (refer to Section 5.1).

#### **NOTE**

Before starting-up the equipment, it should be checked as to whether software module A1630 is mounted on PC board A1600.

Before touching any board (especially the A1600 electronics board), the operator must discharge himself electrically, in order to protect the electronic components from high voltages, generated as a result of electrostatic charging. This can be easily realized by touching a conductive, grounded object immediately beforehand (e.g. bare metal cubicle components).

Boards must not come into contact with highly-insulating materials (e.g. plastic foils, insulating desktops, clothing articles manufactured from man-made fibers).

Boards must only be placed on conductive surfaces.



## WARNING

This converter contains hazardous voltages and rotating mechanical components (fans). Death, severe bodily injury and material damage can occur if the instructions in this Manual are not observed.

On the customer side, a dangerous voltage level can be connected to a signaling relay.

The converters **MUST NOT** be connected to a supply with earth-leakage circuit-breaker (VDE 0160, Section 6.5) as a DC component can be included in the fault current when a fault to frame or ground occurs, which either prevents or hinders a higher-level earth-leakage circuit-breaker from tripping. In this case all loads connected to this earth-leakage circuit-breaker also have no protection.

Only qualified personnel who are familiar with all of the safety instructions contained in this Manual and all installation, operating and maintenance instructions can work on the equipment.



This converter must be professionally transported, stored, installed and mounted and carefully operated and serviced to ensure perfect, safe and reliable operation.

The converter is at a hazardous voltage level even when the converter line contactor is open. The gating board (the board mounted directly in the lower part of the housing) has many circuits at hazardous voltage levels. Before carrying-out any service or maintenance work, disconnect **ALL** power sources from the converter supply and lock-out.

This Manual does not claim to list all of the measures required to ensure safe and reliable operation of the converter. For special applications, additional, supplementary information or instructions might be required. If problems do occur and you feel in any way uncertain, please contact your local Siemens office or representative.

Death, severe personal injury or significant material damage can occur if non-authorized parts and components are used to repair/service this equipment or if unqualified personnel handle it. All of the safety instructions in this manual and all warning labels on the equipment itself must be observed.

Please observe all warning notes in section 1 of this Manual.



## 7.2 Operator control panels

The basic converter is always equipped with the simple operator panel subsequently described. The converter can be optionally equipped with a converter operator control panel when it is disconnected from the supply. This is automatically identified by the basic converter.

### NOTE

When a converter operator panel is connected, the simple operator control panel only displays the operating status (P000), and cannot be used for making any entries. The converter operator control panel can be used for making entries, and has additional capabilities over the simple operator control panel.

### 7.2.1 Simple operator control panel

The simple operator control panel is located at the bottom right behind the converter door cover and consists of a 5-digit, 7-segment display unit; the three LEDs are used for status display and the three keys for parameterization.

All adaption, settings and measurements required for start-up can be executed using the simple operator control panel.

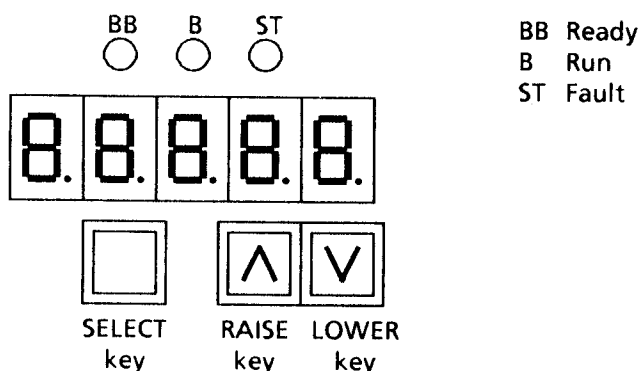

- **SELECT key**
  - Changeover between parameter number (parameter mode), parameter value (value mode) and index number for indexed parameters (index mode).
  - Accelerates the rate of change initiated by the RAISE or LOWER key.
  - Acknowledges a fault message.
- **RAISE key**
  - Selects a higher parameter number in the parameter mode. When the highest parameter is reached, a jump can be made to the other end of the numbers by depressing the key again (the highest number is thus adjacent to the lowest number).
  - Increases the selected and displayed parameter value in the value mode.
  - Increasing the index in the index mode (for indexed parameters)
  - Starting a function selected using parameter P051 (e.g. an optimization run)
  - By simultaneously depressing both keys the LOWER key action is accelerated.

- **Lower key**
  - Selects a lower parameter number in the parameter mode. When the lowest parameter number is reached, a jump can be made to the other end of the numbers by depressing the key again (the highest number is thus adjacent to the lowest number).
  - Decreases the selected and displayed parameter value in the value mode.
  - Reduces the index in the index mode (for indexed parameters).
  - Terminates a function selected using parameter P051 (e.g. an optimization run)
  - By simultaneously depressing both keys the RAISE key action is accelerated.

#### LED functions

##### Ready (BB) green LED

LED lit ⇒ converter in the "wait for operating enable" status (o1).  
(refer to Section 8.1, Operating statuses)

##### Run (B) yellow LED

LED lit ⇒ converter in the "torque direction switched-in" status (M I , MII , M0).  
(refer to Section 8.1, Operating statuses)

##### Fault (ST) red LED

LED lit ⇒ converter in the "fault signal present" status (o11)  
(refer to Section 8.1, Operating statuses and 8.2, Fault messages).

LED flashes ⇒ if an alarm is present.  
(refer to Section 8.3, Alarms)

## 7.2.2 Converter operator control panel

The optional operator control panel (Order No.: 6RX1240-0AP20) is either mounted in the converter door, or outside the converter (refer to Section 5.3 "Installing the software board and options"). It consists of a plain text display unit (2 x 16-digit LCD), 5 LEDs for the status display and 8 keys.

The availability of the converter operator control panel is automatically identified by the basic converter. The plain text display contrast can be adjusted by the operator. The adjusting screw of the contrast potentiometer is accessible in the operating panel frame when the converter door is open.

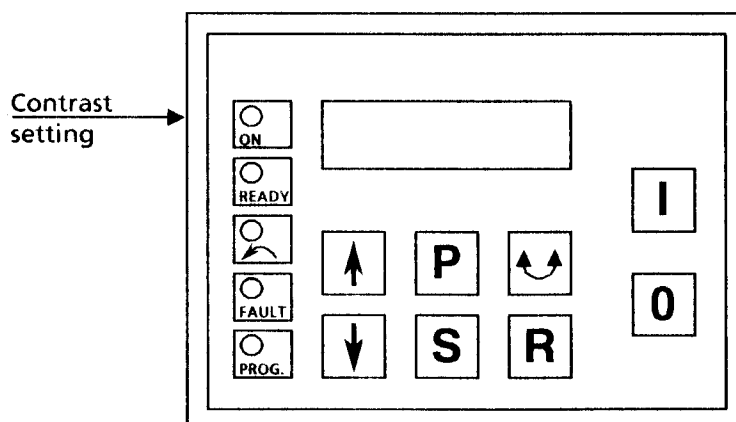

- **P key**
  - Changeover from the OPERATING DISPLAY mode to the PARAMETERIZATION mode.
  - In the PARAMETERIZATION mode, mode changeover between parameter number (parameter mode), parameter value (value mode) and index number for indexed parameters (index mode).
  - A change, initiated using the RAISE or LOWER key in the PARAMETERIZATION mode, can be accelerated by simultaneously depressing the P key.
- **RAISE key**
  - Selects a higher parameter number in the parameter mode. When the highest parameter number is reached, a jump can be made to the other end of the numbers by depressing the key again (the highest number is thus adjacent to the lowest number), also refer to "access to the technology board parameters" (Section 7.3.1).
  - Increases the displayed parameter value in the value mode.
  - Increases the index in the index mode (for indexed parameters)
  - Starting a function, selected using parameter P051 (e.g. an optimization run)
  - By simultaneously depressing both keys the LOWER key action is accelerated.
- **LOWER key**
  - Selects a lower parameter number in the parameter mode. When the lowest parameter number is reached, a jump can be made to the other end of the numbers by depressing the key again (the highest number is thus adjacent to the lowest number), also refer to "access to the technology board parameters" (Section 7.3.1).
  - Decreases the displayed parameter value in the value mode.
  - Decreases the index in the index mode (for indexed parameters)
  - Cancelling a function selected using parameter P051 (e.g. an optimization run).
  - By simultaneously depressing both keys the RAISE key action is accelerated.
- **R key**
  - Changeover from the PARAMETERIZATION mode into the OPERATING DISPLAY mode.
  - Acknowledging a fault message.
  - The actual alarms are displayed in the OPERATING DISPLAY mode. The OPERATING DISPLAY can re-selected by depressing again.
- **I key**
  - Activating the converter from SW2.00  
(Selecting the function using parameter P066)
  - Caution:**  
Even if the "I" key was not depressed, components within the converter can still be at a hazardous voltage level!
- **0 key**
  - Shuts the converter down from SW2.00  
(Selecting the function using parameter P067)
- **∧∧ key**
  - Presently no function
- **S key**
  - Presently no function

**LED functions****ON** yellow LED

LED lit ⇒ Converter in the "torque direction switched-in" status (M I , MII, M0).  
(refer to Section 8.1, Operating statuses)

**READY** green LED

LED lit ⇒ Converter in the "wait for operating enable signal" status (o1).  
(refer to Section 8.1, Operating statuses)

**Counter-clockwise rotation** yellow LED

LED lit ⇒ Negative speed actual value

**FAULT** red LED

LED lit ⇒ "Fault signal present" (o11)  
(refer to Section 8.1, Operating statuses and 8.2, Fault messages)

LED flashes ⇒ "Alarm present"  
(the alarm can be displayed in the operating status display by depressing the R key) (refer to Section 8.3, Alarms)

**PROG.** green LED

LED lit ⇒ "Parameter mode"  
(The parameter number is changed by depressing the RAISE or LOWER key.)  
or  
"Index mode"  
(The index of an indexed parameter is changed by depressing the RAISE or LOWER key.)

LED flashes ⇒ "Value mode", also refer to "access to the technology board parameters"  
(Section 7.3.1)  
(The parameter value can be changed by depressing the RAISE or LOWER key.)

LED dark ⇒ "Value mode", also refer to "Access to the technology board parameters"  
(Section 7.3.1)  
(The value of the selected parameter cannot be changed.  
The key parameter is not correctly set, or a value is involved which cannot be changed, e.g. display parameter.)

The operator control panel can have two modes:

**PARAMETERIZATION mode:**

(When using a technology board as supplementary board, also refer to Section 7.3.1)

- **Parameter mode** (selecting a parameter using the RAISE or LOWER key)

|       |   |   |   |   |   |               |
|-------|---|---|---|---|---|---------------|
| n     | P | x | x | x | ← | Designator    |
| Value |   |   |   |   |   | Units or Text |

An arrow next to the parameter number in the converter operator control panel display, indicates that this can be changed.

- **Index mode** (selecting an index using the RAISE or LOWER key)

|       |  |   |   |   |   |            |
|-------|--|---|---|---|---|------------|
|       |  | . | i | i | ← | Designator |
| Value |  |   |   |   |   |            |

An arrow next to the parameter number in the converter operator control panel display, indicates that this can be changed.

- **Value mode** (changing a parameter value using the RAISE or LOWER key)

|       |   |   |   |   |   |               |
|-------|---|---|---|---|---|---------------|
| n     | P | x | x | x |   | Designator    |
| Value |   |   |   |   | ← | Units or Text |

An arrow next to the parameter value in the operator control panel display indicates that this can be changed. If an arrow does not appear, then it either involves a value which cannot be changed (e.g. display parameter or offline parameter in the "ON" status), or the key parameter is not correctly set (also refer to "access to the technology board parameters", Section 7.3.1). For details, refer to Section 7.3 "Procedure when parameterizing".

The P key is used to changeover between the two modi.

The OPERATING DISPLAY mode is selected with the R key.

**OPERATING DISPLAY mode:**

- **Single-value display** (displaying the parameter selected with parameter P064; P065 = 0!)

|       |   |   |   |   |  |               |
|-------|---|---|---|---|--|---------------|
| n     | P | x | x | x |  | Designator    |
| Value |   |   |   |   |  | Units or Text |

- Two-value display (displays the parameter selected with parameter P064 in the 1st line, and the parameter selected with parameter P065, in the 2nd line, P065 is not 0)

|   |   |   |   |   |   |       |      |
|---|---|---|---|---|---|-------|------|
| n | P | x | x | x | = | Value | Unit |
| n | P | x | x | x | = | Value | Unit |

The PARAMETERIZATION mode is selected using the P key.

Caution: In the OPERATING DISPLAY mode, only parameters between P000 and P048 are displayed!  
 For indexed parameters (e.g. P047, fault diagnostics memory), only the value to index 0 is displayed.

Converter operator control panel modes

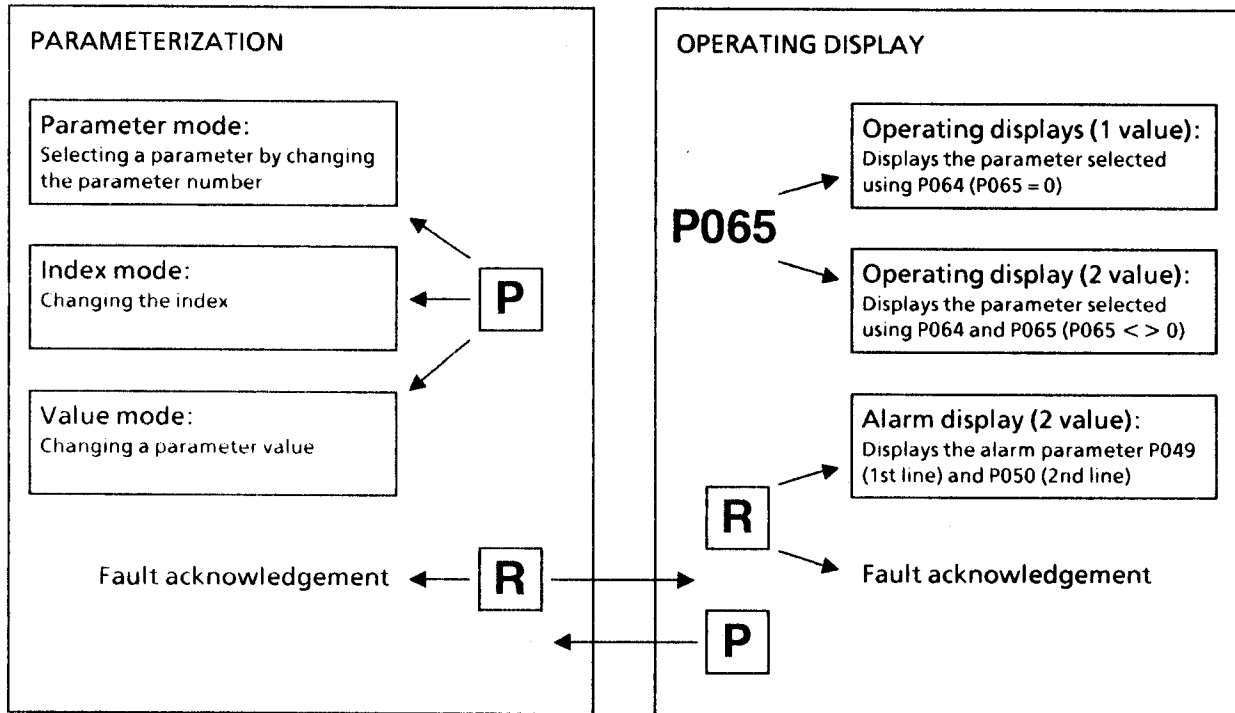

### 7.3 Procedure when parameterizing

Parameterizing means changing parameter values and activating converter functions using the operator control panel.

The parameters are arranged as follows:



Parameters P000 to P099:

- Display parameter
- Definition of the SIMOREG converter
- Definition of the power section
- Converter control

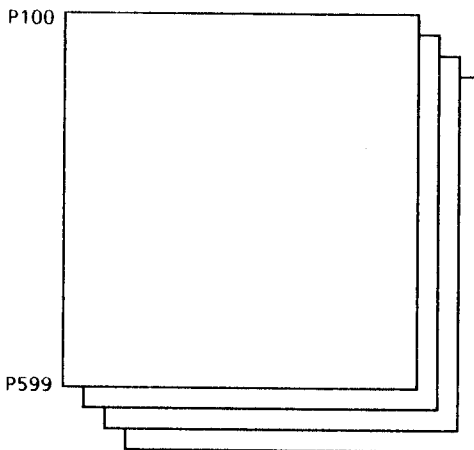

Parameters P100 to P599:

There are 4 parameter sets in this range. Each parameter number is assigned four values, one value per parameter set:

- Motor definition
- Pulse encoder definition
- "Motor interface" option
- Closed-loop control optimization
- Settings for monitoring and limit values
- Settings for the basic converter technology functions

Parameter P054 defines, which of the 4 parameter sets are displayed.

Parameter sets, 2, 3 or 4 are activated using the binary input functions (e.g. via the binary select input, refer to P761 to P766).

Parameter P056 indicates the activated parameter set.

Note: Parameter sets 2 to 4 can first be activated from software release 2.00 onwards.

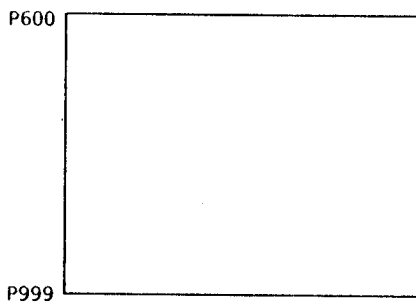

Parameters P600 to P999:

- Structuring of the closed-loop control
- Definition of the converter hardware interface
- Configuration of the serial basic converter interfaces
- Disabling fault/error signals
- Others

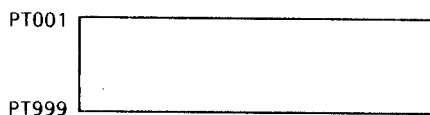

Parameters PT001 to PT999: from SW2.00  
Technology board parameters can only be accessed, if the board is selected via parameter P900, and the operator control panel is used (refer to Section 7.3.1).

Depending on the value of parameter P052, not all parameter numbers will be displayed (refer to Section 9.1 "Parameter overview").

When changing the parameter number, depending on parameter P052, when depressing the RAISE or LOWER key, it can take up to approx. 1 s until the next number is displayed. The reason for this is the internal search for the next parameter number to be displayed.

## Parameter sets

The parameters in the range P100 to 599 are available 4x (sets 1 to 4). Parameter P054 is only used to select the parameter set to be displayed. To identify the displayed parameter set on the basic converter operator panels, the number 2 to 4 is displayed in front of the parameter number in the parameter range P100 to P599. Only the parameter number is displayed if parameter set 1 is selected.

Example for parameter set 2, parameter P100:



The actually activated parameter set is defined using the binary input functions BEF33, 34, 35 (refer to Section 10.3.33, 34, 35) and displayed at parameter P056.

## Parameter types

**Display parameters** are used to display actual quantities, such as e.g. main setpoint, armature voltage, setpoint-actual value difference of the speed controller etc. The parameter values of display parameters can only be read, and cannot be changed using parameterization.

**Decimal parameters** are used to display decimal values, such as e.g. rated motor current, thermal motor time constant, speed controller P gain etc., and they can also be changed using parameterization.

**Hexadecimal parameters** are used to display and to change using parameterization, values, such as e.g. control words for the converter control, control word for the pulse encoder, protocol selection for an interface etc. In this case, each digit has its own meaning.

**Special parameters** are used to display, in a special form, values such as the operating status, the status of the binary inputs and outputs, limits etc.

**Indexed parameters** are used to display and to change several parameter values which are assigned to one parameter number. These include field parameters, such as e.g. displaying the fault/error diagnostic memory, where the individual values are selecting using an index, as well as parameters whose individual values belong to one of four parameter sets, which are selected using parameter P054.

Access to indexed parameters:

After selecting an indexed parameter, the parameter value is not displayed as for other parameter types when the SELECT or P key is depressed, but the index. This can be changed by depressing the RAISE or LOWER key.

The parameter value associated with the selected index is displayed by depressing the SELECT- or P key again. This can be changed by depressing the RAISE or LOWER key.

The parameter number is re-displayed when the SELECT or P key is depressed again.



## Simple operator control panel:

SELECT key on A1600

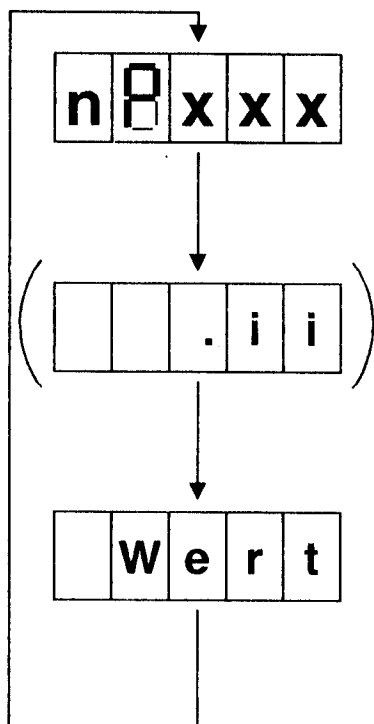

## Converter operator control panel:

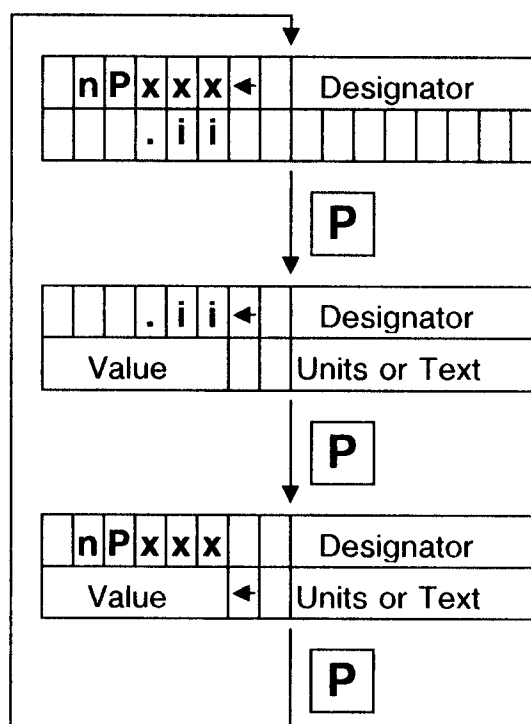

## Parameterization using the simple operator control panel

1. Select the parameter number of the parameter to be changed.  
Select the parameter mode by depressing the SELECT key, and the actual parameter number is then displayed on the 7-segment display.  
Select the required parameter number by depressing the RAISE or LOWER key.  
The selected parameter number "n P x x x" is displayed.
2. Select the value mode by depressing the SELECT key, so that the actual parameter value is displayed (when selecting an indexed parameter, the index mode first appears, refer to the diagram above, or Section 7.2.2).
3. Change the parameter value by depressing the RAISE or LOWER key.

## CAUTION!

Parameter changes are only possible under the following conditions:

- The appropriate access authorization is set using key parameter P051, e.g. "10" (refer to Section 9.2 "Parameter description").
- The converter is in the corresponding operating condition. Parameters, with the "offline" characteristic cannot be changed in the "run" operating condition (online). To change, if required, go into the operating condition  $\geq$  o1.0 (e.g. "ready").  
for software release 2.00 and above:  
For several "offline" parameters, in the operating condition between o1.0 (wait for operating enable) and o7.0 (wait for switch-on), a parameter value change can result in status o8.0 (wait for acknowledgement or switch-on inhibit)! Thus, an automatic, undesirable transition into the RUN status (online) with simultaneously "holding" of the parameter value is prevented. Otherwise, e.g. for P761 (function of binary select input 1) could result in a transition into inching operation, when value 13 is "overdriven".

- The value of display parameters and special parameters cannot be changed.
- It is not possible to change technology board parameters using the simple operator control panel.

The new value of the selected parameter is displayed.

4. Changeover into the parameter mode by depressing the SELECT key, to select the next parameter to be changed or to prevent the parameter value from being accidentally changed.

**NOTES:**

By simultaneously depressing the SELECT key, the selection of a parameter number or changing a parameter value using the RAISE or LOWER key, can be accelerated by a factor of 10.

Due to the large number parameters and the large value range of certain parameters, it is possible to accelerate the rate of change by a factor of 100. Incrementing is realized by depressing the RAISE key and then the LOWER is simultaneously depressed. Decrementing is realized in the same way by depressing the LOWER key and then the RAISE key is simultaneously depressed

For several critical parameters, it is not possible to accelerate the rate of change of parameter values in the RUN operating status (online). These values can only be slowly changed. In operating statuses  $\geq 01.0$  (offline), parameter values can also be quickly changed.

**Parameterization using the converter operator control panel**

1. In the PARAMETERIZATION mode, select the parameter number of the parameter to be changed:

If required, changeover to the PARAMETERIZATION mode in the parameter mode by depressing the P key.

An arrow appears in the display, which indicates the parameter number. This can now be changed.

Select the required parameter number by depressing the RAISE or LOWER key.

The selected parameter number "n P x x x" is displayed in the 1st line of the display, and the 8-digit parameter designator.

The actual value of this parameter and the units and the text or a special status display is displayed in the 2nd line (e.g. the operating status display for P00).

|       |   |   |   |   |   |               |
|-------|---|---|---|---|---|---------------|
| n     | P | x | x | x | ← | Designator    |
| Value |   |   |   |   |   | Units or Text |

2. The value mode is selected by depressing the P key (when selecting an indexed parameter, the index mode is first displayed, refer to the diagram on the previous page and Section 7.2.2).

An arrow then appears in the display which indicates the parameter value of the selected parameter, if this can be changed (refer to "Access to the technology board parameters", Section 7.3.1).

|       |   |   |   |   |   |      |            |
|-------|---|---|---|---|---|------|------------|
| n     | P | x | x | x |   |      | Designator |
| Value |   |   |   |   | ← | Unit |            |

3. Change the parameter value by depressing the RAISE or LOWER key.

**CAUTION!**

Parameters can only be changed under the following conditions:

- The appropriate access authorization is set using key parameter P051, e.g. "10" (refer to Section 9.2 "Parameter description").
- The converter is in the corresponding operating condition. Parameters, with the "offline" characteristic cannot be changed in the "run" operating condition (online). To change, if required, go into an operating condition  $\geq$  o1.0 (e.g. "ready").  
for software release 2.00 and above:  
For several "offline" parameters, in the operating condition between o1.0 (wait for operating enable) and o7.0 (wait for switch-on), a parameter value change can result in status o8.0 (wait for acknowledgement or switch-on inhibit)! Thus, an automatic, undesirable transition into the RUN status (online) with simultaneously "holding" of the parameter value is prevented. Otherwise, e.g. for P761 (function of binary select input 1) could result in a transition into inching operation, when value 13 is "overdriven".
- The values of display and special parameters cannot be changed.
- P051 is insignificant when changing technology board parameters however, P910 must be 1 (change rights).

The parameter value of the selected parameter is updated in the display.

**NOTES:**

By simultaneously depressing the SELECT key, the selection of a parameter number or changing a parameter value using the RAISE or LOWER key, can be accelerated by a factor of 10.

Due to the large number parameters and the large value range of certain parameters, it is possible to accelerate the rate of change by a factor of 100. Incrementing is realized by depressing the RAISE key and then the LOWER is simultaneously depressed. Decrementing is realized in the same way by depressing the LOWER key and then the RAISE key is then simultaneously depressed.

For several critical parameters, it is not possible to accelerate the rate of change of parameter values in the RUN operating status (online). These values can only be slowly changed. In operating statuses  $\geq$  o1.0 (offline), parameter values can also be quickly changed.

4. Changeover into the parameter mode by depressing the SELECT key, to select the next parameter to be changed or to prevent the parameter value from being accidentally changed.

### 7.3.1 Accessing technology board parameters

from SW2.00

When the technology board is selected (P900 = 3 or 4), technology board parameters are displayed on the converter operator control panel, when increasing the parameter above the highest basic converter parameter (exception: P052 = 0  $\Rightarrow$  only displays changed parameters).

**Caution:**

Technology parameters cannot be accessed via the simple operator control panel on the A1600 electronics board!

The technology parameter range is from **PT001** to **PT999**. All parameter numbers are displayed, however, additional information is only displayed for actually configured parameters (parameter value, units, designator).

The parameter mode for changing the parameter number is identified by an arrow next to the parameter number and when the PROG LED is lit.

The value mode for changing a parameter value is identified by a flashing PROG LED. Contrary to the basic converter parameters, "flashing" does not mean that the parameter value can actually be changed. Further, an arrow is not displayed next to the parameter value (not possible for long values), but a "?" next to the parameter number.

All parameter types, with the exception of parameters, type X4 (double word), NF (floating point format) or OF (index) can be presently displayed.

All parameters, types x2 and B1 can be presently changed.

If the parameter value is longer than 8 characters, in the second operator control panel line, only the value and no units are displayed. Parameter values, which are longer than 16 characters, cannot be displayed. The overflow display then appears in the second line of the operator control panel ("XXXXXXXX ...").

PT parameter value changes are first only realized on the display. The new value is only transferred when the parameter mode is selected by depressing the P key. The value is then transferred into the technology board RAM (and then becomes effective) as well as in the permanent memory i.e. it is not sensitive to supply failures.

Caution:

If the parameter mode is not selected after changing the PT parameter value, the change remains ineffective and is lost when the electronics power supply is switched-off!

### 7.3.2 List of possible operator control panel displays

#### Converter operator control panel

#### Simple operator control panel

|       |   |   |   |   |  |               |
|-------|---|---|---|---|--|---------------|
| n     | P | x | x | x |  | Designator    |
| Value |   |   |   |   |  | Units or Text |

Operating display (1-value)

|   |   |   |   |   |   |       |      |
|---|---|---|---|---|---|-------|------|
| n | P | x | x | x | = | Value | Unit |
| n | P | x | x | x | = | Value | Unit |

Operating display (2-value)

|       |   |   |   |   |   |               |
|-------|---|---|---|---|---|---------------|
| n     | P | x | x | x | ← | Designator    |
| Value |   |   |   |   |   | Units or Text |

P mode for basic converter parameters

|   |   |   |   |   |
|---|---|---|---|---|
| n | P | x | x | x |
| n | P | x | x | x |

|       |   |   |   |   |   |            |
|-------|---|---|---|---|---|------------|
| P     | T | x | x | x | ← | Designator |
| Value |   |   |   |   |   | Unit       |

P mode for technology parameters

**Converter operator control panel**

|       |  |   |   |   |   |               |
|-------|--|---|---|---|---|---------------|
|       |  | . | i | i | ← | Designator    |
| Value |  |   |   |   |   | Units or Text |

Index display

|       |   |      |   |   |  |            |
|-------|---|------|---|---|--|------------|
| n     | P | x    | x | x |  | Designator |
| Value | ← | Unit |   |   |  |            |

W mode

|   |   |   |   |   |   |            |
|---|---|---|---|---|---|------------|
| n | P | x | x | x |   | Designator |
| X | X | X | X | X | ← | Unit       |

Over- / underflow display

|   |    |    |    |    |    |   |   |   |   |   |   |   |   |   |   |   |
|---|----|----|----|----|----|---|---|---|---|---|---|---|---|---|---|---|
| W | 14 | 13 | 12 | 11 | 10 | 9 | 8 | 7 | 6 | 5 | 4 | 3 | 2 | 1 | 0 |   |
| W | 1  | 1  | 1  | 1  | 1  | 1 | 1 | 1 | 1 | 1 | 1 | 1 | 1 | 1 | 1 | 1 |
| W | 1  | 1  | 1  | 1  | 1  | 1 | 1 | 1 | 1 | 1 | 1 | 1 | 1 | 1 | 1 | 1 |

Alarm display in the OPERATING DISPLAY mode

|  |  |   |   |   |   |   |   |   |   |   |   |   |   |   |   |
|--|--|---|---|---|---|---|---|---|---|---|---|---|---|---|---|
|  |  | P | 0 | 1 | 1 |   |   | B | i | n | . | o | u | t | p |
|  |  | 0 | 0 | 0 | 0 | 0 | 0 | 1 | 0 | 0 | 1 | 1 | 1 | 1 | 0 |
|  |  |   |   |   |   |   | 7 |   |   |   | 4 | 3 | 2 | 1 |   |

Logical status display, e.g P011

|   |   |   |   |   |   |   |   |   |   |   |   |   |   |   |
|---|---|---|---|---|---|---|---|---|---|---|---|---|---|---|
| D | e | f | a | u | l | t |   | v | a | l | u | e | s | ? |
| Y | / | N | = | U | p | / | D | o | w | n |   |   |   |   |

Prompt to press key (factory setting)

|   |   |   |   |   |   |   |   |   |   |   |   |   |   |
|---|---|---|---|---|---|---|---|---|---|---|---|---|---|
| O | f | f | s | e | t | - | A | d | j | u | s | t | ? |
| Y | / | N | = | U | p | / | D | o | w | n |   |   |   |

Prompt to press key (offset compensation)

|   |   |   |   |   |   |   |   |   |   |   |   |   |   |   |
|---|---|---|---|---|---|---|---|---|---|---|---|---|---|---|
| I | a | / | I | f | - | R | e | g | . | - | T | u | n | ? |
| Y | / | N | = | U | p | / | D | o | w | n |   |   |   |   |

Prompt to press key (optimization run)

|   |   |   |   |   |   |   |   |   |   |   |   |   |   |
|---|---|---|---|---|---|---|---|---|---|---|---|---|---|
| P | a | r | a | m | . | - | O | u | t | p | u | t | ? |
| Y | / | N | = | U | p | / | D | o | w | n |   |   |   |

Prompt to press key (parameter output)

**Simple operator control panel**

|  |  |  |   |   |   |
|--|--|--|---|---|---|
|  |  |  | . | i | i |
|--|--|--|---|---|---|

|   |   |   |   |   |
|---|---|---|---|---|
| V | a | l | u | e |
|---|---|---|---|---|

|  |  |  |  |  |
|--|--|--|--|--|
|  |  |  |  |  |
|--|--|--|--|--|

|  |   |   |    |    |    |    |    |    |
|--|---|---|----|----|----|----|----|----|
|  | 0 | 1 | 2  | 3  | 4  | 5  | 6  | /  |
|  | 8 | 9 | 10 | 11 | 12 | 13 | 14 | 15 |

|  |  |  |  |  |
|--|--|--|--|--|
|  |  |  |  |  |
|--|--|--|--|--|

|  |  |  |  |  |
|--|--|--|--|--|
|  |  |  |  |  |
|--|--|--|--|--|

|  |  |  |  |  |
|--|--|--|--|--|
|  |  |  |  |  |
|--|--|--|--|--|

|  |  |  |  |  |
|--|--|--|--|--|
|  |  |  |  |  |
|--|--|--|--|--|

**Converter operator control panel**

|   |   |   |   |   |   |   |   |   |   |   |   |   |   |   |   |
|---|---|---|---|---|---|---|---|---|---|---|---|---|---|---|---|
| P | a | r | a | m | e | t | e | r | - | I | n | p | u | t | ? |
| Y | / | N | = | U | p | / | D | o | w | n |   |   |   |   |   |

Prompt to press key (read-in parameter)

|   |   |   |   |   |   |   |   |   |   |   |   |   |   |   |   |
|---|---|---|---|---|---|---|---|---|---|---|---|---|---|---|---|
| S | e | n | d |   | T | r | a | c | e | - | B | u | f | . | ? |
| Y | / | N | = | U | p | / | D | o | w | n |   |   |   |   |   |

Prompt to press key (trace buffer print-out)

|   |   |   |   |   |   |   |   |   |   |   |   |   |   |   |   |
|---|---|---|---|---|---|---|---|---|---|---|---|---|---|---|---|
| I | a | / | I | f | - | R | e | g | . | - | T | u | n | . |   |
| S | t | a | t | u | s |   |   |   |   |   |   | o | 7 | . | 0 |

In the operating status  $\geq 01.0$ , wait until the "RUN" status

|   |   |   |   |   |   |   |   |   |   |   |  |  |  |  |  |
|---|---|---|---|---|---|---|---|---|---|---|--|--|--|--|--|
| P | a | r | a | m | e | t | e | r |   |   |  |  |  |  |  |
| D | o | w | n | l | o | a | d | i | n | g |  |  |  |  |  |

Wait for received data

|   |   |   |   |   |   |   |   |   |   |   |   |   |   |   |  |
|---|---|---|---|---|---|---|---|---|---|---|---|---|---|---|--|
| P | a | r | a | m | e | t | e | r |   | n | P | x | x | x |  |
| i | s |   | b | e | i | n | g |   | d | o | n | e |   |   |  |

Activity display (establish factory setting)

|   |   |   |   |   |   |   |   |   |   |   |   |   |   |   |   |
|---|---|---|---|---|---|---|---|---|---|---|---|---|---|---|---|
| O | f | f | s | e | t | - | A | d | j | u | s | t | . |   |   |
| D | o | i | n | g |   | s | t | e | p | . | 0 | 6 | : | 0 | 4 |

Activity display (hardware adaption)

|   |   |   |   |   |   |   |   |   |   |   |   |   |   |   |   |
|---|---|---|---|---|---|---|---|---|---|---|---|---|---|---|---|
| I | a | / | I | f | - | R | e | g | . | - | T | u | n | . |   |
| D | o | i | n | g |   | s | t | e | p | . | 0 | 7 | : | 0 | 2 |

Activity display in the operating status  $< 01.0$

|   |   |   |   |   |   |   |   |   |   |   |   |   |   |   |  |
|---|---|---|---|---|---|---|---|---|---|---|---|---|---|---|--|
| P | a | r | a | m | e | t | e | r |   | n | P | x | x | x |  |
| i | s |   | t | r | a | n | s | m | i | t | t | e | d |   |  |

Activity display (parameter output)

|   |   |   |   |   |   |   |   |   |   |   |   |   |   |   |  |
|---|---|---|---|---|---|---|---|---|---|---|---|---|---|---|--|
| P | a | r | a | m | e | t | e | r |   | n | P | x | x | x |  |
| i | s |   | b | e | i | n | g |   | r | e | a | d |   |   |  |

Activity display (read-in parameter)

**Simple operator control panel**

|   |  |  |   |   |
|---|--|--|---|---|
| P |  |  |   |   |
| Y |  |  | Y | Y |

|   |  |  |   |   |
|---|--|--|---|---|
| P |  |  |   |   |
| Y |  |  | Y | Y |

|   |  |   |   |   |
|---|--|---|---|---|
| ▲ |  |   |   |   |
| 0 |  | 0 | 0 | 0 |

|   |   |   |   |   |
|---|---|---|---|---|
| ▶ | ▶ | ▶ | ▶ | ▶ |
|---|---|---|---|---|

|   |   |   |   |   |
|---|---|---|---|---|
| n | P | x | x | x |
|---|---|---|---|---|

|   |   |  |   |   |
|---|---|--|---|---|
| 0 | 6 |  | 0 | 4 |
|---|---|--|---|---|

|   |   |  |   |   |
|---|---|--|---|---|
| 0 | 7 |  | 0 | 2 |
|---|---|--|---|---|

|   |   |   |   |   |
|---|---|---|---|---|
| n | P | x | x | x |
|---|---|---|---|---|

|   |   |   |   |   |
|---|---|---|---|---|
| n | P | x | x | x |
|---|---|---|---|---|

### Converter operator control panel

|   |   |   |   |   |   |   |   |   |   |   |   |   |   |  |  |
|---|---|---|---|---|---|---|---|---|---|---|---|---|---|--|--|
| T | r | a | c | e | - | B | u | f | f | e | r |   |   |  |  |
| i | s |   | t | r | a | n | s | m | i | t | t | e | d |  |  |

Activity display (trace buffer print-out)

|   |   |   |   |   |   |   |   |   |   |  |  |  |  |  |  |
|---|---|---|---|---|---|---|---|---|---|--|--|--|--|--|--|
| F | a | u | l | t |   | F | 0 | 0 | 4 |  |  |  |  |  |  |
| A | r | m | . |   | p | h | a | s | e |  |  |  |  |  |  |

Example of a fault message

### Simple operator control panel

## 7.4 Reset to default value and adjust offset

Establishing the factory parameter settings and executing offset adjustments for the main actual value input and field current actual value.

The "establish factory setting" function must be executed, if the software board A6130 has been replaced.

The "reset to default" can be executed if a defined basic setting is to be established, e.g. in order to carry-out a complete new start-up.

### NOTE

All system-specific set parameters are overwritten (deleted) with "reset to default". It is therefore recommended that all of the old settings are printed-out with P051 = 12, or stored in the PC or PG with P051 = 16, prior to carrying-out "reset to default".

If "reset to default" is executed, then a complete new start-up must be carried-out, as otherwise the converter is not ready for operation for safety reasons.

Call-up the function with:

**P051 = 21**                      Reset to default

Procedure:

- 1) Remove terminal block XT (terminals 101 to 104)
- 2) Set parameter **P051 = 21**
- 3) Depress the SELECT key on the simple operator control panel (PC board A1600) or depress the P key on the converter operator control panel (option). The "dEF" text appears on the simple operator control panel to indicate that when acknowledging, a default setting will be established, and 2 key symbols will flash as prompt to depress one of the two keys below.

A prompt text appears on the operator control panel as to whether the selected function should be really executed.

|   |   |   |   |   |   |   |   |   |   |   |   |   |   |   |
|---|---|---|---|---|---|---|---|---|---|---|---|---|---|---|
| D | e | f | a | u | l | t |   | v | a | l | u | e | s | ? |
| Y | / | N | = | U | p | / | d | o | w | n |   |   |   |   |

- 4a) This is acknowledged and the function is started by depressing the RAISE key.
- 4b) The function is immediately aborted by depressing the LOWER key (all parameter values remain unchanged).
- 5) After the function has been started, several parameters must be manually set. For this reason, at first, only the parameters listed below can be selected.

Parameters to be manually set:

- P070 (gating board type)
- P071 (rated converter supply voltage)
- P072 (rated converter current/armature  
this parameter setting must correspond to the actually mounted armature load resistors)
- P073 (rated converter current/field  
this parameter setting must coincide with the actually mounted field shunt resistors)
- P074 (control word for the power section)
- P076 (European/US power section)

In order to correctly complete the "reset to default" function, each of these parameters must be selected, and its parameter value either changed to the required value, or the recommended value confirmed by changing over into the value mode. An acknowledged/confirmed parameter is identified by a point in front of the parameter number.

It is possible to scroll up and down within the parameter list in the parameter mode by depressing the RAISE or LOWER key. It is therefore possible to correct, as many times as required, an already set parameter value.

These manual settings are completed by depressing the RAISE key in the parameter mode so that one goes beyond the highest parameter number to be set (i.e. beyond P076) If all values were confirmed/acknowledged or set, then the next step for establishing the factory setting is started.

- 6) Transferring the parameter values into the EEPROM memory.  
The parameter values are saved in the EEPROM memory so that they are also available when the converter is switched-off. This procedure takes about 35 s, and is visualized by displaying the currently-processed parameter number (052 to 999). Parameters P000 to P051 are display parameters, whose values cannot be saved. The electronics power supply must be energized during this 35 seconds.
- 7) Offset adjustment  
Parameters P884, P885 and P886 (offset adjustment) are set (duration, approx. 10s).
- 8) Re-insert terminal block XT (terminals 101 to 104).

Offset adjustment can also be activated as individual function using parameter  
**P051 = 22.**



## 7.5 Start-up steps



### WARNING



This converter has hazardous voltage levels, even when the converter line contactor is open. The gating board (the lower PC board mounted directly on the housing) has many circuits at hazardous voltage levels.

Death, severe bodily injury and material damage can occur if the instructions specified in this Instruction Manual are not observed.



### 1 Check the plug-in jumpers



### CAUTION

The plug-in jumpers must only be changed with the electronics power supply switched-off!

Refer to Section 6.8 "Terminal connecting diagram" and Section 6.8.1 "Settings" for location and setting of the plug-in jumpers when the equipment is supplied.

The plug-in jumpers should be inserted according to the relevant circuit-diagrams and the required functions.

Plug-in jumper XJ1 on board A1600 must be in the 1-2 position (no hardware write protection for the parameter memory).



### 2 Adapting the rated converter currents (if required)



### CAUTION

The load resistors must only be changed with the electronics power supply switched-off!

The rated converter armature DC current must be adjusted by removing the armature load resistors, if:

$$\frac{\text{max. armature current}}{\text{rated converter armature DC current}} < 0.5$$

The rated converter armature current can be reduced to  $\frac{2}{3}$  or  $\frac{1}{3}$  of the rated converter DC current by removing the armature load resistors.

The rated converter field DC current must be adjusted by removing the field shunt resistors if:

$$\frac{\text{max. field current}}{\text{rated converter field DC current}} < 0.5$$

The rated converter DC current can be reduced by removing field shunt resistors.

Refer to Section 6.6 "load resistors" for detailed information about the reduced rated currents.



### Access authorization

P051 ... Key parameter  
 P052 ... Selecting the parameter to be displayed

Parameter changes are only possible with the appropriate access authorization set in key parameter P051 (refer to P051 in Section 9.2 "Parameter description")

The parameters which are to be displayed are selected using parameter P052 (refer to Section 9.1. "Parameter overview").



### Correcting the converter ratings if the load resistors have been changed

P072 ... rated converter DC current (armature)  
 P073 ... rated converter DC current (field)  
 P075 ... control word for the I<sup>2</sup>t of the power section



### Entering motor data

The motor data, according to the motor rating plate, must be entered into parameters P100, P101, P102 and P114.

P100 ... design armature current  
 P101 ... design armature voltage  
 P102 ... design field current  
 P114 ... motor thermal time constant (refer to Section 10. "Functions")



### Information regarding speed actual value sensing

Selecting the speed actual value source and setting the maximum speed

Enter into parameter P083:

**P083 = 0:** Actual value source still not selected



#### Operation with analog tachometer

**P083 = 1:** Define tachometer input  
 P706 - 270.00V to + 270.00V  
 Rated input voltage at  $n_{max}$   
 (= tachometer voltage at maximum speed)  
 P708 = 0x nothing is connected at terminals 101, 102 and 103  
 P708 = 1x Tachometer connected to terminal 101 (range, 80V to 250V)  
 P708 = 2x Tachometer connected to terminal 102 (range, 25V to 80V)  
 P708 = 3x Tachometer connected to terminal 103 (range, 8V to 25V)



#### Operation with pulse encoder

**P083 = 2:** Set pulse encoder data  
 P140 Pulse encoder, type  
 P141 Pulse encoder, pulse number  
 P142 Pulse encoder, control word  
 P143 Maximum speed, rough  
 P452 Maximum speed, fine



### 6.3 Operation without tachometer (EMF closed-loop control)

**P083 = 3:** Select maximum speed  
**P115** 1.00 to 120.00% of the rated converter supply voltage (P071)  
 When using the internal EMF actual value as speed actual value, the speed is adjusted using this parameter. The parameter specifies where the maximum speed should be at which EMF as a percentage of P071.



### 6.4 Freely-wired actual value

**P083 = 4:** Define the actual value input with P609  
**P609** Number of the connector, to which the speed controller actual value is connected.



## 7 Field data

Entering parameter P082:

- P082 = xx0:** Internal field is not used  
(e.g. for permanently-excited motors)
- P082 = xx1:** The field is switched together with the supply (main) contactor  
(the field pulses are switched-in/-out together with the main contactor)
- P082 = xx2:** The standstill field, set using P257 is automatically switched-in after a time which can be parameterized via P258, after operating status 07 or higher is reached.
- P082 = xx3:** Field current continuously switched-in
- P082 = x0x:** No speed- or EMF-dependent field weakening  
(internally, 100% field current setpoint is continuously entered)
- P082 = x1x:** Field weakening operation using the internal closed-loop EMF control, so that in the field weakening range, i.e. at speeds above the motor rated speed (= "threshold speed"), the motor EMF is kept constant at the setpoint  $EMF_{set}$  (K289) =  $P101 - P100 * P110$ .

As supplied: 002



## 8 Select basic technological functions



### 8.1 Current limits

**P171** System current limit in torque direction I  
**P172** System current limit in torque direction II



### 8.2 Torque limits

**P180** Torque limit 1 in torque direction I  
**P181** Torque limit 1 in torque direction II



### 8.3 Ramp-function generator

**P303** Acceleration time 1  
**P304** Deceleration time 1  
**P305** Initial rounding-off 1  
**P306** Final rounding-off 1



### Execute optimization runs

- The drive must be in operating status o7.0 or higher (enter SHUTDOWN!).
- Select optimization run using key parameter P051.

**P051 = 25**    **Pre-control and current controller for armature and field (duration, approx. 40s).** The following parameters are automatically set: P110, P111, P112, P155, P156, P255, P256, P884 and P887.

#### NOTE

Permanent field motors (and motors with an extremely high remanence), must be mechanically locked during this optimization run.



#### WARNING



The adjusted current limits are not effective during the current controller optimization run. 75% of the rated motor armature current flows for approx. 0.7s. Further, individual current spikes of approx. 120% of the motor rated armature current are generated.

**P051 = 26**    **Speed controller optimization run (duration, min. 6s)**  
The following parameters are automatically set: P225, P226 and P228.

Note:

The speed controller optimization run only takes into account speed controller actual value filtering, parameterized at P200, and, for software release 2.00 and above, for P083 = 1, also main actual value filtering, parameterized at P709. For P200 < 20 ms, P225 (gain) is limited to 30.0. The speed controller optimization run also sets P228 (speed setpoint filtering) and P226 (speed controller integral action time) for optimal control performance for step-like setpoint changes.



#### WARNING



During the speed controller optimization run, the motor is accelerated with a maximum of 45% of the rated motor armature current. The motor can reach speeds of up to approximately 20% of the maximum speed.

If field weakening is selected (P082 = x1x), if closed-loop torque control is selected (P170 = x1) or torque limiting (P170 = 1x) or if a variable field current setpoint is input:

**P051 = 27**      **Optimization run for field weakening** (duration, approx. 1min)  
The following parameters are automatically set: P117 to P139, from software release 2.00, also P275 and P276.

**Note:**

In order to determine the magnetization characteristic, the field current setpoint is reduced during the optimization run from 100% of the motor rated field current, according to P102, down to a minimum of 8%. The field current setpoint is limited to a minimum according to P103 by parameterizing P103 to values < 50% of P102 for the duration of this optimization run. This might be necessary for uncompensated motors with a very high armature reaction.

The magnetization characteristic is approximated, starting from the measuring point with minimum field current setpoint, linearly to 0.

To execute this optimization run, the minimum motor field current (P103), must be parameterized for < 50% of the rated motor field current (P102).



### WARNING

The drive accelerates up to approximately 80% of the rated motor speed during this optimization run (the armature voltage is a maximum of 80% of the rated motor armature voltage (P101)).

**P051 = 28**      **Optimization run for friction- and moment of inertia compensation (if required)** (duration, min. 40s)      from SW1.10  
The following parameters are automatically set: P520 to P530, P540



### WARNING

The drive accelerates up to the maximum speed during this optimization run.

After this optimization run has been completed, the friction- and moment of inertia compensation must be manually activated with P223 = 1!

When the closed-loop current/torque control mode is changed with P170, the optimization run for the friction- and moment of inertia compensation must be repeated.

**Note:**

To execute this optimization run, it is not permissible that the speed controller is parameterized as pure P controller or as controller with droop.

After selecting the required optimization run using P051 = 25, 26, 27 or 28:

- Depress the SELECT- or P keys
- A prompt appears to depress a key as follows (example for P051 = 25):

Converter operator control panel

|   |   |   |   |   |   |   |   |   |   |   |   |   |   |   |   |
|---|---|---|---|---|---|---|---|---|---|---|---|---|---|---|---|
| I | a | / | I | f | - | R | e | g | . | - | T | u | n | . | ? |
| Y | / | N | = | U | p | / | D | o | w | n |   |   |   |   |   |

Simple operator control panel



Depressing the HIGHER key means: Execute optimization run  
 Depressing the LOWER key means: Do not execute optimization run (abort)

- If yes: The operator panel display changes to the appropriate operating status-display mode for the optimization run, as long as the unit is in an operating condition  $\geq 01.0$ . For example, the following operating status display appears:

Converter operator control panel

|   |   |   |   |   |   |   |   |   |   |   |   |   |   |   |  |
|---|---|---|---|---|---|---|---|---|---|---|---|---|---|---|--|
| O | p | t | i |   | I | a | / | I | f | - | R | e | g | . |  |
| B | e | t | r | . | z | u | s | t | . |   | o | 7 | . | 0 |  |

Simple operator control panel



In operating condition  $\geq 01.0$  wait for the status "RUN"

On the simple operator control panel a bar, which moves up and down at the 1st position, indicates that it is an operating status display during the optimization run.

- The optimization run can be stopped by depressing the LOWER key (function abort).
- Entering the SWITCH-ON and OPERATING ENABLE commands.
- The optimization run is executed- when an operating condition  $< 01.0$  (RUN) is reached. The operator control panel display then changes to the appropriate activity display. For example, the following activity display appears:

Converter operator control panel

|   |   |   |   |   |   |   |   |   |   |   |   |   |   |   |   |
|---|---|---|---|---|---|---|---|---|---|---|---|---|---|---|---|
| I | a | / | I | f | - | R | e | g | . | - | T | u | n | . |   |
| D | o | i | n | g |   | s | t | e | p | . | 0 | 7 | : | 0 | 2 |

Simple operator control panel



Activity display in operating status  $< 01.0$

During the particular optimization run, which is processed in a sequence of individual steps, as so-called "program step controll", code numbers are displayed in the simple- or operator control panel, indicating the particular optimization run activity. Two, two-digit numbers are displayed, which are separated by a bar moving up and down, or by a colon, identifying the presently executed program step.

**NOTE****from SW2.00**

For limited travel:

From software release 2.00 onwards, the optimization run for field weakening (P051 = 27) can only be interrupted after the 1st field weakening measuring point has been plotted, or the optimization run for the friction- and moment of inertia compensation (P051 = 28), at the earliest after the measuring point for 10% of the maximum speed has been determined, by entering SHUTDOWN, without initiating fault message F052. After the optimization run has been re-started (P051 = 27 or P051 = 28), this is continued at a more advanced position. In this way, the particular optimization run can be completed in several stages, even for limited travel.

Note:

If a fault message is displayed during the optimization run, the electronics power supply is switched-off before the optimization run is restarted, another parameter set must be previously selected, or in the meantime, another optimization run started, so the particular optimization run is again completely executed after a new start.

Parameters from sets 2, 3 or 4 can be automatically optimized, if before starting the optimization runs, the appropriate parameter set is selected using binary input functions BEF33, 34 or 35.

The parameter set must remain selected during the optimization run, otherwise a fault message is output.

- P051 is indicated in the operator control panel at the end of the optimization run.

**NOTE**

Optimization runs should be executed in the sequence specified above (pre-control and current controller, speed controller, field weakening control, friction- and moment of inertia compensation).

The determined parameters are dependent on the motor temperature. The automatically selected values for the motor in the cold state can be used as a good pre-setting.

For dynamic, high-performance drives, optimization step P051 = 25 should be repeated after the drive has been operated under load (i.e. with the motor warm).

10

**Checking and possible fine adjustment of the maximum speed**

The fine adjustment of the maximum speed is dependent on the selected speed actual value source. The speed actual value source selection and adjustment of the maximum speed is described under point 6.

If the maximum speed is now adjusted by more than approx. 10%, the control characteristics of the speed control loop must be checked, and if necessary, the speed controller optimized again, or a manual post optimization.

The optimization run for field weakening and the friction- and moment of inertia compensation must be repeated for each speed adjustment change.



## Manual (post) optimization (if required)

(also refer to Section 7.6 "Manual optimization")

### Pre-control and current controller for armature and field

The manual setting of the parameters for the pre-control is described in Section 7.6 "Manual optimization".

#### Speed controller

|      |  |
|------|--|
| P200 | Speed actual value filtering           |
| P225 | Speed controller, P gain               |
| P226 | Speed controller, integral-action time |
| P227 | Speed controller, droop                |
| P228 | Speed setpoint filtering               |

#### Note:

P228 is set the same as P226 from the speed controller optimization run (P051 = 26) (speed controller integral action time) (to optimize the response for step setpoint changes). When using the ramp-function generator, it is practical to parameterize a lower speed setpoint filtering (P228).

Setting "experience" values and optimization with the setpoint control box according to the generally-valid optimization guidelines.

#### EMF controller

|      |                                      |
|------|--------------------------------------|
| P275 | EMF controller, P gain               |
| P276 | EMF controller, integral-action time |

Setting "experience" values and optimization with the setpoint control box according to the generally-valid optimization guidelines.



## Setting supplementary functions

(e.g. activating supplementary monitoring functions, refer to P850, Section 9.2)



13

**Activate parameter memory inhibit (if required)****NOTE**

If the parameter memory inhibit is to be activated (write protection active), the following should be noted:

- Automatic restart not possible (set P086 to 0.0!)
- P880 (fault memory contents) is lost when the electronics power supply is disconnected
- P048, P871 and P872 are lost when the electronics power supply is disconnected.
- The setpoint and direction of rotation of the motorized potentiometer is lost when the electronics power supply is disconnected (set P460 to x0x!).
- K309, K310 and K311 are lost when the electronics power supply is disconnected.

If one of these points is required, the parameter memory inhibit may not be activated!

- Select parameter P053 (write protection per software)
- Set plug-in jumper XJ1 on board A1600 into position 2-3 (hardware write protection)

**CAUTION**

The plug-in jumper must only be changed when the electronics power supply is switched-off!

14

**Change the parameter to be displayed (if required)**

Appropriately set parameter P052 (refer to Section 9 "Parameter list").

Appropriately set parameter P054, to display parameter set 1, 2, 3 or 4.

15

**Document the setting values**

- Document parameters  
If P052 = 0, only those parameters are displayed on the operator control panel, which deviate from the factory setting.
- Print-out parameters with P051 = 11 or P051 = 12 (refer to Sections 9 "Parameter list")
- Transfer parameters to the PG or PC, with P051 = 15 or P051 = 16 (refer to Sections 9 "Parameter list")  
(the PGIN software is required for the PG, and for the PC, the PCIN software)

## 7.6 Manual optimization (if required)

### 7.6.1 Manual setting of the armature resistance $R_A$ (P110) and armature circuit inductance $L_A$ (P111)

- Setting the armature circuit parameter according to the motor list

Disadvantage: The data is very inaccurate and the actual values can deviate significantly.

For the armature circuit resistance, the feeder resistances are not taken into account. For the armature voltage inductance, additional smoothing reactors and the feeder inductances are also not taken into account.

- Rough estimation of the armature circuit parameters from the motor and supply data  
Armature resistance P110

$$R_A [\Omega] = \frac{\text{Rated motor armature voltage [V] (P101)}}{10 \times \text{Rated motor armature current [A] (P100)}}$$

The basis for this formula is that at the rated armature current, 10% of the rated armature voltage drops across the armature circuit resistance  $R_A$ .

Armature circuit inductance P111

$$L_A [\text{mH}] = \frac{1.4 \times \text{rated converter supply voltage of armature power section [V] (P071)}}{\text{Rated motor armature current [A] (P100)}}$$

The basis for this formula is the experience value: The transition from discontinuous to continuous current is at approx. 28.6% of the rated motor armature current.

- Determining the armature circuit parameters by measuring the current/voltage
  - Select current-controlled operation: **P084 = 2**
  - Set parameter **P153 = 0** (pre-control disabled)
  - The field should be switched-off using **P082 = xx0** and, if the motor remanance is high, the rotor should be locked so that it does not rotate.
  - Set the overspeed protection threshold **P354 = 5%**
  - Enter main setpoint = 0
  - An armature current of approx. 0% flows if "OPERATION ENABLE" is present, and the "SWITCH-ON" command is entered.

Calculating the armature circuit resistance P110 from the measured armature current and voltage values

- Slowly increase the main setpoint (displayed at P001), until the armature current actual value reaches approx. 70% of the rated motor armature current (P019 as a % of the rated converter armature current).
- Read-out P019 (armature current actual value) and convert into amps (using P100).

- Read-out P038 (actual armature voltage in Volts)
- Calculate the armature circuit resistance:

$$R_A [\Omega] = \frac{P038}{P019 \text{ (converted into amps)}}$$

- Adjust the armature circuit resistance at parameter P110

Calculating the armature circuit inductance P111 from the measured armature current at the transition from discontinuous to continuous current.

- Make an oscilloscope trace of the armature current (e.g. at terminal 12)  
Slowly increase the main setpoint (indicated at P001) starting from 0, until the armature current reaches the transition from discontinuous to continuous current.
- Measure the armature current at the transition (at standstill  $EMF = 0$ )  $I_{LG, EMF=0}$ , or read the value from P019, and convert into amps using P100.
- Measure the phase-to-phase voltage of the armature power section  $U_{supply}$ , or read the value from P015.
- Calculate the armature circuit inductance using the following formula:

$$L_A [mH] = \frac{0.4 \times U_{supply} [V]}{I_{LG, EMF=0} [A]}$$

- Adjust the armature circuit inductance at parameter P111.

## 7.6.2 Manual setting of the field resistance $R_F$ (P112)

- Rough estimation of the field resistance  $R_F$  (P112) from the motor rated field data

$$R_F = \frac{\text{Rated motor field voltage}}{\text{Rated motor field current (P102)}}$$

- Adapting the field resistance  $R_F$  (P112) using the field current setpoint-actual value comparison
  - Set parameter P112 = 0, this results in a 180° field pre-control output, and thus the field current actual value = 0
  - Set parameter P082 = xx3, so that the field remains always switched-in, even when the line contactor is out
  - Set parameter P254 = 00, i.e. only the field pre-control is active, and the field current controller is switched-off
  - Set parameter P102 to the design field current
  - Increase parameter P112 until the actual field current (P035 converted into amps using P073), is the same as the setpoint demanded (P102).
  - Reset parameter P082 to the operational system value.



## 8 Operation

### 8.1 Operating statuses, parameter P000

- Torque direction M0, MI or MII (= ON)**
- No torque direction switched-in (M0)
  - I Torque direction I switched-in (MI)
  - II Torque direction II switched-in (MII)
- o1 Wait for enable signal (= READY)**
- o1.0** Brake release delay time running
  - o1.1** Wait for enable signal at terminal 38
  - o1.2** Wait for operating enable via control word, bit 3 from SW1.10
  - o1.3** Delay time after inching command has been withdrawn running
  - o1.4** Wait until field reversal has been executed. from SW2.00
  - o1.5** Delay time for enable signal from the optimization run  
(the optimization run only outputs the enable signal at the end, if  $n < n_{\min}$  has been reached, and SHUTDOWN has been entered).
  - o1.6** Wait for operating enable from the checkback signal "line contactor in"  
(select function: BEF55 binary input function)
- o2 Reserved**
- o2.0** Reserved
- o3 Test phase**
- o3.0** Wait until the thyristor check has been completed (select function)
  - o3.1** Wait until the supply symmetry check has been completed.
- o4 Wait for voltage (armature)**
- o4.0** Wait for voltage at the power connections 1U1, 1V1, 1W1.  
(threshold:  $P071 * \frac{P353}{100\%}$  )
- o5 Wait for field current**
- o5.0** Wait until the field current actual value is >50% of the field current setpoint and  
" $I_{\text{field external}} > I_{f \min}$ " (if BEF59 is used).
  - o5.1** Wait for voltage at power connections 3U1, 3W1.  
(threshold:  $400V * \frac{P353}{100\%}$  )

#### NOTE

In statuses o4 and o5, a maximum specific time is maintained, which can be selected using parameter P089. If the appropriate conditions are still not fulfilled, the associated error/fault signal is issued.

- o6 Wait status before the main contactor is switched-in from SW2.00**
- o6.0** Wait until the auxiliaries are switched-in (delay time P093).
- o6.1** Wait until a setpoint  $\leq$  P091 is available at the ramp-function generator input.
- o7 Wait for switch-on (= READY FOR SWITCH-ON)**
- o7.0** Wait for switch-on via terminal 37
- o7.1** Wait for switch-on via control word, bit 0. **from SW1.10**
- o7.2** Wait until the internal shutdown is removed by entering an external shutdown command or  
wait for BEF58 = 0 after "braking with field reversal" (BEF58 = 1) **from SW2.00**
- o7.3** Wait until "reset to default" has been completed.
- o7.4** Wait for a manual start command to execute an action (e.g. "reset to default", "optimization run" or wait until "offset compensation" has been completed).
- o7.5** Wait until the "read-in parameter set" has been completed.
- o8 Wait for switch-on inhibit acknowledge**
- o8.0** Wait for the switch-on inhibit to be acknowledged by entering the command SHUTDOWN (OFF 1).
- o9 Fast stop (OFF 3)**
- o9.0** Fast stop was entered via terminal  
(select function: Binary input function 4).
- o9.1** Fast stop was input via control word, bit 2. **from SW1.10**
- o9.2** Fast stop is internally stored (the memory is reset by removing the FAST STOP command and entering "SHUTDOWN").
- o10 Voltage disconnect (OFF 2)**
- o10.0** Command to disconnect the voltage was entered via terminal  
(select function: Binary input function 3).
- o10.1** Disconnect from voltage input via control word, bit 1. **from SW1.10**
- o10.2** Emergency stop was entered via terminal 105 or 107.
- o10.3** Wait until a valid telegram is received from the partner drive  
(only if "peer-to-peer" communication selected, parameter P780/P790). **from SW1.10**
- o10.4** Wait until a valid USS telegram was received at GSST1 **from SW2.00**  
(only if the telegram failure time monitoring P797  $< >$  0).
- o10.5** Wait until a valid USS telegram was received at GSST0 **from SW2.00**  
(only if the telegram failure time monitoring P787  $< >$  0).
- o11 Fault**
- o11.0** = Fxxx error message is displayed, red LED is lit.

**o12 Electronics is initialized****o12.0** Supplementary board (CS5/51 or PT1) is initialized **from SW1.20****o12.1** Basic converter electronics is initialized**o13 Electronics not under voltage****Display dark:** Wait for voltage at terminals 5U1, 5W1  
(electronics power supply)**8.2 Fault messages**

When a fault occurs:

- The binary output function "fault" (BAF3) is set to LOW, and bit 3 of the status word ZSW (K325) is set to HIGH.
- the drive is shutdown (as for "Voltage disconnect" Section 10.3.3)
  1. technology controller, ramp-function generator, speed- and current controllers are inhibited
  2.  $\alpha_w$  (inverter stability limit) is entered
  3. the pulses are inhibited when  $I = 0$
  4. "Close operating brake" signal (BAF14 = 0, status word ZSW1 bit 7 = 0) is output, if P080 is parameterized to 2 **from SW2.00**
  6. for operating statuses  $\geq o10$ , a field current actual value (K265) present 13 field firing pulse cycles previously, is entered as field current setpoint upper limit, to prevent armature overvoltage in field weakening operation. This limit is removed if the operating status is  $\leq o5$
  5. operating status o11.0 is reached
  7. the "line contactor ON" relay drops-out
  8. the drive coasts down (or is braked by the operating brake)
  9. delay time, which can be parameterized (P258) expires
  10. the field is reduced to a value which can be parameterized (P257)
  11. if  $n < n_{min}$  (P370, P371) is reached, the "close holding brake" signal (BAF14 = 0, status word ZSW1 bit 7 = 0) is output, if P080 is parameterized to 1. **from SW1.20**
- The fault is displayed on the operator control panel.

Fault display, simple operator control panel: Fxxx (xxx = fault number)  
 Display flashes (approx. 0.8s lit, 0.2s dark)  
 Red LED "ST" on the electronics board lit

Fault display, operator control panel:  
 1st line: Fault xxx (xxx = fault number)  
 2nd line: "fault text"  
 Red LED "FAULT" lit on the operator control panel.  
 Red LED "ST" lit on the simple operator control panel.  
 o11.0 displayed on the simple operator control panel.

The fault messages only become active above a certain operating status. This operating status is specified in the description of the individual fault messages.

A new fault message can only be displayed, if the previous fault message has been acknowledged (refer to Section 8.2.3) and

1. the "switch-on" command was entered once (positive edge) or
2. a function (e.g. "parameter print-out", "optimization run" etc. was started during a key acknowledged prompt, by depressing the RAISE key.

The binary output function "fault" is issued independent of the fault display.

### Storing the fault number when the electronics power supply fails

The fault memory, parameter P880, contains the numbers of the four faults which last occurred. This at power failure, these are stored, depending on parameter P053.

**P053 = 0x** Process data which is not lost during voltage failure, is not stored

**P053 = 1x** All process data which is not lost during voltage failure (auch Störspeicherinhalt) is stored.

If the process data which is not lost when the voltage fails, is not stored (P053 = 0x), the contents of the fault memory are lost when the converter is switched-off. The converter can become operational after the supply voltage has returned, without a fault message being issued.

If the process data which is not lost during voltage failure, is stored (P053 = 1x), the contents of the fault memory are stored in the EEPROM when the converter is switched-off. If the supply voltage is switched-out with a fault message present, the converter outputs message F040 when the supply voltage returns.

### Fault diagnostics memory

Additional information regarding fault causes is provided in the 16-word fault diagnostic memory, displayed at parameter P047.ii (ii = 0 to 15). The significance of the fault words (word 0, word 1, ...) is explained in Section 8.2.2 for the particular fault messages.

The contents of the fault diagnostic memory can also be printed-out, or transferred to a PG or PC (also refer to P051 in Sections 9.2 and 10.7.1).

#### NOTE

Although in the subsequent description of the individual fault messages, only the significance of word 0 of the fault diagnostic memory is specified, fault words up to word 14 from P047 can provide more detailed information regarding the fault cause. For all fault messages, word 15 contains the fault number in the hexadecimal notation.



## 8.2.1 Fault overview

| Fault No.               | Function  |
|-------------------------|---|
| <b>Supply fault</b>     |   |
| F001                    | Failure of the electronics power supply   |
| F003                    | Faults in parallel SITOR sets   |
| F004                    | Phase failure, armature supply  |
| F005                    | Fault in the field circuit  |
| F006                    | Undervoltage  |
| F007                    | Overvoltage   |
| F008                    | Supply frequency less than 45 Hz  |
| F009                    | Supply frequency greater than 65Hz  |
| <b>Interface errors</b> |   |
| F010                    | Parity error at G-SST0  |
| F011                    | Framing error at G-SST0   |
| F012                    | Overrun error at G-SST0   |
| F013                    | Syntax error at G-SST0  |
| F014                    | USS telegram failure at G-SST0 <span style="float: right;">from SW1.10</span>                                       |
| F015                    | Peer-to-peer error at G-SST0 <span style="float: right;">from SW1.10</span>   |
| F020                    | Parity error at G-SST1  |
| F021                    | Framing error at G-SST1   |
| F022                    | Overrun error at G-SST1   |
| F023                    | Syntax error at G-SST1  |
| F024                    | USS telegram failure at G-SST1 <span style="float: right;">from SW1.10</span>                                       |
| F025                    | Peer-to-peer error at G-SST1 <span style="float: right;">from SW1.10</span>   |
| F028                    | Short-circuit at the binary outputs   |
| F029                    | Faulted connection between the basic converter and supplementary board <span style="float: right;">f. SW1.10</span> |
| <b>Drive faults</b>     |   |
| F031                    | Controller monitoring, speed controller   |
| F032                    | Controller monitoring, armature current controller  |
| F033                    | Controller monitoring, EMF controller   |
| F034                    | Controller monitoring, field current controller   |
| F035                    | Drive stalled   |
| F036                    | No armature current can flow  |
| F037                    | I <sup>2</sup> t motor monitoring responded   |
| F038                    | Überdrehzahl  |
| F039                    | I <sup>2</sup> t monitoring of the power section responded  |
| F040                    | Electronics supply disconnected with a fault present  |
| F041                    | Parameter set or ramp-function generator selection not clear  |

| Fault No.   | Function  |
|---|---|
| F042  | Tachometer fault  |
| F043  | EMF for braking operation too high <span style="float: right;">from SW2.00</span>                       |
| F046  | Analog input, main setpoint (terminals 4 and 5) faulted <span style="float: right;">from SW2.00</span>  |
| F047  | Analog input, select input 1 (terminals 6 and 7) faulted <span style="float: right;">from SW2.00</span> |
| F048  | Fault in the measuring channel for digital pulse encoder speed sensing                                  |
| <b>Start-up faults</b>                                  |   |
| F050  | Optimization run not possible   |
| F051  | Optimization run with permanent memory inhibit not possible   |
| F052  | Optimization run externally interrupted   |
| F055  | Field characteristic was not recorded   |
| F056  | Important parameters not set  |
| F057  | Option selection incorrect  |
| F058  | Parameter settings not consistent   |
| F059  | Function selection for G-SST0 and G-SST1 incorrect  |
| F060  | Modified software version <span style="float: right;">from SW1.10</span>                                |
| <b>Fault messages from the thyristor check function</b> |   |
| F061  | Defective thyristor (short-circuit in module V1) (for the 15 A converter: V1 or V4)                     |
| F062  | Defective thyristor (short-circuit in module V2) (for the 15 A converter: V2 or V5)                     |
| F063  | Defective thyristor (short-circuit in module V3) (for the 15 A converter: V3 or V6)                     |
| F064  | Defective thyristor (short-circuit in module V4) (for the 15 A converter: V4 or V1)                     |
| F065  | Defective thyristor (short-circuit in module V5) (for the 15 A converter: V5 or V2)                     |
| F066  | Defective thyristor (short-circuit in module V6) (for the 15 A converter: V6 or V3)                     |
| F068  | Ground fault in the armature circuit <span style="float: right;">from SW2.00</span>                     |
| F069  | I = 0 signal defective  |
| F071  | Thyristor unable to be triggered (X11)  |
| F072  | Thyristor unable to be triggered (X12)  |
| F073  | Thyristor unable to be triggered (X13)  |
| F074  | Thyristor unable to be triggered (X14)  |
| F075  | Thyristor unable to be triggered (X15)  |
| F076  | Thyristor unable to be triggered (X16)  |
| F077  | 2 or more thyristors (MI) unable to be triggered  |
| F081  | Thyristor unable to be triggered (X21)  |
| F082  | Thyristor unable to be triggered (X22)  |
| F083  | Thyristor unable to be triggered (X23)  |
| F084  | Thyristor unable to be triggered (X24)  |
| F085  | Thyristor unable to be triggered (X25)  |
| F086  | Thyristor unable to be triggered (X26)  |

| Fault No.  | Function   |
|--|--|
| F087   | 2 or more thyristors (MII) unable to be triggered                            |
| F091   | Thyristor unable to block (X11 or X21)                                       |
| F092   | Thyristor unable to block (X12 or X22)                                       |
| F093   | Thyristor unable to block (X13 or X23)                                       |
| F094   | Thyristor unable to block (X14 or X24)                                       |
| F095   | Thyristor unable to block (X15 or X25)                                       |
| F096   | Thyristor unable to block (X16 or X26)                                       |
| <b>Internal faults</b>                             |  |
| F100   | Illegal microprocessor status  |
| F101   | Watchdog timer has initiated a reset   |
| F102   | EEPROM fault   |
| F103   | Parameter value outside the permitted range                                  |
| F104   | Incorrect EEPROM check sum   |
| F105   | Defective RAM  |
| F107   | Internal buffer overflow   |
| F109   | Defective supply voltage sensing   |
| F110   | Converter cooling faulted  |
| F111   | Defective measuring channel for the main setpoint (terminals 4 and 5)        |
| F112   | Defective measuring channel, select input 1 (terminals 6 and 7)              |
| F113   | Defective measuring channel for the main actual value (terminals 101 to 104) |
| <b>Fault messages from the motor sensor system</b> |  |
| F115   | Brush length too low   |
| F116   | Poor bearing condition   |
| F117   | Air flow monitoring  |
| F118   | Motor overtemperature (binary sensing)                                       |
| F119   | Motor overtemperature (analog sensing)                                       |
| <b>External faults</b>                             |  |
| F121   | Fault signal at terminal 39  |
| F122   | Fault signal at terminal 40  |
| F123   | Fault signal at terminal 41  |
| F124   | Fault signal at terminal 42  |
| F125   | Fault signal at terminal 43  |
| F126   | Fault signal at terminal 36  |
| F128 to F255                                       | Technology board fault <span style="float: right;">from SW1.10</span>        |

## 8.2.2 Fault description

### 8.2.2.1 Supply faults

#### **F001 Failure of the electronics power supply**

Active in all operating statuses

##### **Mode of operation**

The electronics power supply (terminals 5U1, 5W1) fails, during "RUN" for longer than the "restart time", set at parameter P086, or the electronics is operated with an undervoltage condition (the voltage at a "discharge capacitor" is a measure of the voltage failure time).

##### **Fault diagnostics memory**

Word 0 1 Electronics power supply is interrupted in "ON" longer than the time set in P086  
 2 Supply failure pre-warning (alarm) responds periodically  
 3 Supply failure pre-warning (alarm) is present for longer than 1.28 seconds

Word 1 If word 0 = 1: Duration of the actual supply failure in 1/10 seconds

##### **Possible fault causes**

- Line contactor opened in the "ON" status
- Brief supply failure
- Supply voltage too low

#### **F003 Faults in parallel SITOR sets**

Active for operating statuses ≤ o4

##### **Mode of operation**

At least one parallel SITOR set is connected, selected via parameter p074, and provides the fault signal, phase failure, fan monitoring or undervoltage.

For "undervoltage in a parallel SITOR set" the error message is only initiated, if the error condition occurs for a time longer than the "restart time" set at P086.

##### **Fault diagnostics memory**

Word 0 1 Fuse failure  
 2 Fuse failure  
 3 Undervoltage  
 4 Undervoltage after the time, set at P086, has expired

##### **Possible fault causes**

- Undervoltage in the electronics power supply of a SITOR set
- A fan is not running
- Fuse failure in a SITOR set
- Cable connection between a SIMOREG converter and first SITOR set is interrupted or faulty
- No parallel SITOR set present, although selected via P074

**F004 Phase failure, armature supply**

Active for operating statuses ≤ o4

**Mode of operation**

The supply voltage RMS value, calculated from the area of each supply half wave (rectified average value x peak factor) must be greater than the response value of the phase failure monitoring.

$$\left( P071 * \frac{P353}{100\%} \right)$$

The distance between two similar supply voltage zero crossovers of a phase must not exceed 450 degrees.

If one of these two conditions is not fulfilled for longer than the "restart time" set at P086, the error message is initiated.

**Fault diagnostics memory**

- Word 0
- 1 Voltage failure in the armature supply (1U1, 1V1, 1W1)
  - 2 Delay time according to parameter P089 expired in operating status o4
  - 3 Fuse failure in the SITOR set
  - 4 Voltage failure longer than the time set in parameter P086 (if this is > 0)

**Possible fault causes**

- Parameter P353 incorrectly set
- Armature phase failed
- Line contactor opened in operation
- Fuse blown on the three-phase side in the armature circuit
- Fuse failure in the SITOR set

**F005 Fault in the field circuit**

Active for operating statuses ≤ o5

**Mode of operation**

The supply voltage RMS value, calculated from the area of each supply half wave (rectified average value x peak factor) must be greater than the response value of the phase failure monitoring.

$$\left( P078 * \frac{P353}{100\%} \right) \text{ from SW2.00, } \left( 400V * \frac{P353}{100\%} \leq SW1.30 \right)$$

The distance between two similar supply voltage zero crossovers for the field rectifier must not exceed 450 degrees.

The field current actual value is < 50% of the required field current setpoint for greater than 500 ms. This monitoring function is only effective, if the field current setpoint > 2% of the rated converter field current.

The binary input  $I_{\text{field}} < I_{\text{min}}$  (select function) is LOW for more than 500 ms.

The error message is initiated, if one of the described error conditions is available for a time longer than the "restart time" set at P086.

**Fault diagnostics memory**

- Word 0
- 1 Voltage failure in the field supply (terminals 3U1 and 3W1) (for P086 = 0)
  - 2 Delay time in status o5.1 expired  
(delay for voltage to be established in the field power section)
  - 3 delay time according to parameter P089 expired in operating status o5.0  
(wait until  $I_{Field\ act} > 50\%$  of the instantaneous field current setpoint)  
or  
the field current actual value was  $< 50\%$  of the field current setpoint in "ON" for more than 0.5 s  
or  
binary input  $I_{Field} < I_{min}$  (select function) is LOW for more than 500 ms)
  - 4 Voltage failure or  $I_{field\ act} < 50\% I_{field\ set}$  longer than that set at parameter P086 (if this  $> 0$ ).

**Possible fault causes**

- Threshold for the phase failure (P353) incorrectly set
- Field phase failed
- Line contactor opened in operation
- Fuse failure in the field circuit
- Field current controller and/or field current controller pre-control either not optimized or badly optimized (check P112, P253 to P256; if required, carry-out current controller optimization run)

**F006 Undervoltage**

Active for operating statuses  $\leq o4$

**Mode of operation**

Voltage at terminals 1U1, 1V1 or 1W1 or 3U1, or 3W1 is less than the response threshold (P071 and P351) for longer than the "restart time" set at P086.

Response threshold for the armature supply voltage:  $P071 * (1 + \frac{P351}{100\%})$

Response threshold for the field supply voltage:  $P078 * (1 + \frac{P351}{100\%})$

$(400V * (1 + \frac{P351}{100\%}))$  from SW1.30

**Fault diagnostics memory**

- Word 0
- 1 Undervoltage condition
  - 4 Undervoltage lasts longer than the time set using parameter P086 (if this  $> 0$ )

if word 0 = 1, then

Word 1 Phase number which caused the fault message

- 0 Phase UV
- 1 Phase VW
- 2 Phase WU
- 3 Phase field

Word 2 Erroneous voltage value (normalized to 16384)

**Possible fault causes**

- Supply undervoltage
- Monitoring set too critically or incorrectly (P351, P071)
- Gating board type (P070) incorrectly set

**F007 Overvoltage**

Active for operating statuses  $\leq o4$

**Mode of operation**

Voltage at terminals 1U1, 1V1 or 1W1 and 3U1, 3W1 greater than the response threshold (P071 and P352) (for longer than the "restart time" set at P086).

Response threshold for the armature supply voltage:  $P071 * (1 + \frac{P352}{100\%})$

Response threshold for the field supply voltage:  $P078 * (1 + \frac{P352}{100\%})$

$(400V * (1 + \frac{P351}{100\%}))$  from SW1.30

**Fault diagnostics memory**

Word 0 1 Overvoltage condition  
 4 Overvoltage condition lasts longer than the time set using parameter P086 (if this > 0)

if word 0 = 1, then

Word 1 Phase number which led to the fault/error signal  
 0 Phase UV  
 1 Phase VW  
 2 Phase WU  
 3 Phase field

Word 2 Incorrect voltage value (normalized to 16384)

**Possible fault causes**

- Supply overvoltage
- Monitoring set too critically or incorrectly (P352, P071)
- Gating board type (P070) incorrectly set

**NOTE**

This monitoring function is disabled when supplied. The monitoring function is activated at parameter P850 (refer to Section 8.2.4).

**F008 Supply frequency less than 45 Hz**

Active for operating statuses  $\leq o5$

**Mode of operation**

This error signal is activated, if the supply frequency is < 45 Hz (for longer than the "restart time" set at P086).

**Fault diagnostics memory**

Word 0 1 Armature supply frequency <45Hz  
 2 Field supply frequency <45Hz

**F009 Supply frequency greater than 65Hz**

Active for operating statuses  $\leq 05$

**Mode of operation**

This fault message is activated if the supply frequency is greater than 65 Hz (for longer than the "restart time" set at P086).

**Fault diagnostics memory**

Word 0 1 Armature supply frequency >65Hz  
2 Field supply frequency >65Hz

**8.2.2.2 Interface errors****F010 Parity error at G-SST0**

Active in all operating statuses, if parameter P780 = xxx1 or xxx9

**Mode of operation**

The bytes received at serial interface 0 (X500), are monitored for the selected parity (P780).

**Possible error causes**

- Check the parity set at parameter P780
- Parity incorrectly set at the transmitting unit
- EMC interference along the connecting cable

**F011 Framing error at G-SST0**

Active in all operating statuses, if parameters P780 = xxx1 or xxx9

**Mode of operation**

The bits received at serial interface 0 (X500), are monitored for the selected number of stop bits (P780).

**Possible error causes**

- Check the data frame set at parameter P780
- Incorrectly set baud rate at the transmitting unit
- EMC interference along the connecting cable

**F012 Overrun error at G-SST0**

Active in all operating statuses, if parameter P780 = xxx1 or xxx9

**Mode of operation**

Each byte received at serial interface 0 (x500) must be retrieved by the software from the receive buffer, before the next character has been completely received. An error signal is initiated if this is not the case.

**Possible error causes**

- Incorrectly set baud rate at the transmitting unit
- EMC interference along the connecting cable



**F013 Syntax error at G-SST0**

Active in all operating statuses, if the "read-in parameter from the PC" function is selected (P780 = xxx1 and P051 = 23).

**Mode of operation**

A syntax error occurred when reading-in a parameter set via the serial interface (X500). The error signal is first initiated at the end of a transmission, and does not interrupt an actual transmission.

**Fault diagnostics memory**

- Word 0
- 1 Invalid character received between two parameter declarations
  - 2 Invalid character received within a parameter declaration
  - 3 Too many places after the decimal point were specified for the parameter value
  - 4 Too many digits were specified for nibble-coded parameters
  - 5 Parameter specified which is outside the permitted limits
  - 6 Nibble-coded parameters specified outside the setting range
- Word 1 Last valid received parameter number of the complete transmission (as hexadecimal number)
- Word 2 Last valid received parameter number before the last error occurred (as hexadecimal number)
- Word 3 Index of the last valid received parameter number before the last error occurred (as hexadecimal number)

**Possible fault causes**

- Errors in the transferred data
- Errors occurred during transfer (unlikely!)

**F014 USS telegram failure at G-SST0****from SW1.10**

This is active after the first valid protocol has been received, in all operating statuses.

**Mode of operation**

After a valid protocol has been received, no further telegram was received for a time longer than that set at parameter P787 (also refer to P787 in Section 9.2).

**Possible fault causes**

- Interrupted cable
- USS master error

**F015 Peer-to-peer error at G-SST0** **from SW1.10**  
**Function partially changed from software release 2.00**

Active for operating statuses  $\geq 06$

**Mode of operation**

After a valid protocol has been received, no further telegram was received for a time longer than that set at parameter P788 (also refer to P788 in Section 9.2).

**Possible error causes**

- Connecting cable interrupted
- EMC noise on the connecting cable
- P788 set too low

**F020 Parity error at G-SST1**

Active in all operating statuses, if parameters P790 = xxx1 or xxx9

**Mode of operation**

The bytes received at serial interface 1 (X501) are monitored for the selected parity (P790).

**Possible error causes**

- Check the parity set at parameter P790
- Incorrect parity set at the transmitting unit
- EMC interference along the connecting cable

**F021 Framing error at G-SST1**

Active in all operating statuses, if parameter P790 = xxx1 or xxx9

**Mode of operation**

The bytes received at serial interface 1 (X501) are monitored for the selected number of stops bits (P790).

**Possible error causes**

- Check the data frame set at parameter P790
- Incorrectly set baud rate at the transmitting unit
- EMC interference along the connecting cable

**F022 Overrun error at G-SST1**

Active in all operating statuses, if parameter P790 = xxx1 or xxx9

**Mode of operation**

Each bit received at serial interface 1 (X501) must be retrieved from the receive buffer by the software, before the next character is completely received.

If this is not the case, the error signal is initiated.

**Possible error causes**

- Incorrectly set baud rate at the transmitting unit
- EMC interference along the connecting cable

**F023 Syntax error at G-SST1**

Active in all operating statuses, if the "read-in parameter from the PC" function is selected (P790 = xxx1 and P051 = 23).

**Mode of operation**

A syntax error occurred when reading-in a parameter set via the serial interface (X501). The error signal is first initiated at the end of a transmission, and does not interrupt an actual transmission.

**Error diagnostics memory**

- Word 0
- 1 Invalid character received between two parameter declarations
  - 2 Invalid character received within a parameter declaration
  - 3 Too many places after the decimal point were specified for the parameter value
  - 4 Too many digits were specified for nibble-coded parameters
  - 5 Parameter specified which is outside the permitted limits
  - 6 Nibble-coded parameters specified outside the setting range
- Word 1 Last valid received parameter number of the complete transmission (as hexadecimal number)
- Word 2 Last valid received parameter number before the last error occurred (as hexadecimal number)
- Word 3 Index of the last valid received parameter number before the last error occurred (as hexadecimal number)

**Possible fault causes**

- Errors in the transferred data
- Errors occurred during transfer (unlikely!)

**F024 USS telegram failure at G-SST1****from SW1.10**

Active from the first reception of a valid protocol in all operating statuses

**Mode of operation**

After a valid protocol was received, no additional telegram was received for a time longer than that set at parameter P797 (also refer to P788 in Section 9.2).

**Possible fault causes**

- Defective cable
- Fault in the USS master

**F025 Peer-to-peer error at G-SST1****from SW1.10****Function partially changed from software release 2.00**

Active for operating statuses  $\geq 06$

**Mode of operation**

After a valid protocol has been received, no further telegram was received for a time longer than that set at parameter P788 (also refer to P788 in Section 9.2).

**Possible error causes**

- Connecting cable interrupted
- EMC noise on the connecting cable
- P788 set too low

**F028 Short-circuit at the binary outputs**

Active in all operating statuses

**Mode of operation**

Hardware monitoring as to whether the binary select outputs are short-circuited.

**Possible fault causes**

- Short-circuit or overload at terminals 46, 48, 50 or 52

**NOTE**

This monitoring function is disabled when the unit is supplied. The monitoring function is activated at parameter P850 (refer to Section 8.2.4).

**F029 Faulted connection between the basic converter and supplementary board  
from SW1.10**

Active for operating statuses  $\leq o3$

**Mode of operation**

Data transmission between the basic converter and technology- or interface board is monitored per software (also refer to P926 and P927).

**Fault diagnostics memory****Word 0 (channel code)**

- 1 Setpoint channel 1
- 2 Setpoint channel 2
- 3 Actual value channel 1
- 4 Actual value channel 2

**Word 1 (channel code)**

- 1 Buffer still in the initialized status
- 2 Supplementary board has read the buffer to be written into
- 3 Supplementary board has written into the buffer to be read
- 4 Supplementary board has not updated the buffer contents
- 5 Supplementary board has not retrieved the buffer contents
- 6 Channel not operational, although selected via P902 and P906

**Possible fault causes**

- Defective ribbon cable connection between X100 and the supplementary board
- Defective supplementary board
- EMC noise

### 8.2.2.3 Drive faults

#### NOTE

The following monitoring functions F031 to F037 are disabled when the equipment is supplied. The monitoring functions are activated at parameter P850 (ref. to Sec. 8.2.4).

#### **F031 Controller monitoring, speed controller**

Active for operating statuses --, I, II

##### **Mode of operation**

The monitoring responds, if the setpoint-actual value difference of the speed controller exceeds the value set at parameter P362, for a time set at parameter P363.

##### **Possible fault causes**

- Control loop interrupted
- Controller not optimized

#### **F032 Controller monitoring, armature current controller**

Active for operating statuses --, I, II

##### **Mode of operation**

The monitoring function responds, if the setpoint-actual value difference of the armature current controller exceeds the value set at parameter P364 for a time which is longer than that set at P365.

##### **Possible fault causes**

- Control loop interrupted
- Controller not optimized

#### **F033 Controller monitoring, EMF controller**

Active for operating statuses --, I, II

##### **Mode of operation**

The monitoring function responds, if the setpoint-actual value difference of the armature current controller exceeds the value set at parameter P366 for a time which is longer than that set at P367.

The monitoring function is ineffective, if the field current setpoint reaches the positive field current limit (armature control range, non-weakened field).

##### **Possible fault causes**

- Control loop interrupted
- Controller not optimized

**F034 Controller monitoring, field current controller**

Active for operating statuses --, I, II

**Mode of operation**

The monitoring function responds if the setpoint-actual value difference of the field current controller exceeds the value set at parameter P368 for a time which is longer than that set at P369.

**Possible fault causes**

- Control loop interrupted
- Controller not optimized

**F035 Drive stalled**

Active for operating statuses --, I, II

**Mode of operation**

The monitoring function responds, if the following conditions are fulfilled for a time longer than that set at parameter P355:

- Positive or negative torque or armature current limit reached
- The armature current is greater than 1% of the rated converter armature current
- The speed actual value is < 0.4% of the maximum speed

**Possible fault causes**

- Drive stalled

**F036 No armature current can flow**

Active for operating statuses --, I, II

**Mode of operation**

The monitoring function responds if the armature firing angle is at the rectifier stability limit for more than 500 ms, and the armature current is less than 1% of the rated converter armature DC current.

**Possible fault causes**

- Armature circuit interrupted (e.g. DC fuses blown, cable interrupted etc.)
- Rectifier stability limit  $\alpha_G$  (P150) incorrectly set
- Drive operates at the  $\alpha_G$  limit (e.g. as a result of a supply undervoltage condition)
- EMF too high, as the maximum speed is set too high (refer to P083, P115, P143, P608)
- EMF too high, as field weakening is not selected (refer to P082)
- EMF too high, as the field current is set too high (refer to P102)
- EMF too high, as the trip voltage is set too high (refer to P101)

**F037 I<sup>2</sup>t motor monitoring responded**

Active for operating statuses --, I, II

**Mode of operation**

The monitoring function responds, if the I<sup>2</sup>t value reaches a value, which corresponds to the final temperature at 110% of the motor design armature current

**Possible fault causes**

- Parameter P114 incorrectly set
- Drive operated for an excessive time with > 110% of the rated motor armature current

**F038 Überdrehzahl**

Active for operating statuses --, I, II

**Mode of operation**

This fault message is initiated, if the speed actual value (K166) has a value which exceeds the threshold + 0.5% set at parameter P354.

**Possible fault causes**

- Current lower limit input
- Current controlled operation
- P354 set too low
- Tachometer cable contact fault during operation in the vicinity of the maximum speed

**F039 I<sup>2</sup>t monitoring of the power section responded**

Active for operating statuses --, I, II

**Mode of operation**

The monitoring function responds if the calculated I<sup>2</sup>t value of the power section has reached the max. value for that particular power section (also refer to P075 in Section 9.2).

**Possible fault causes**

- Drive operated too long under an overload condition
- Parameter P075 incorrectly set
- Parameter P077 incorrectly set

**F040 Electronics supply disconnected with a fault present**

Active for all operating statuses

**Mode of operation**

This fault message is initiated, if the electronics power supply was switched-off, although a fault message was available and was still not acknowledged.

**Fault diagnostics memory**

Word 0 last available fault signal

**Possible fault causes**

- Not all of the fault messages have been acknowledged

**F041 Parameter set or ramp-function generator selection not clear**

Active for all operating statuses

**Mode of operation**

A software check is made as to whether parameter sets 2 or 3 or 4 have been clearly selected (parameters . P100 to . P599). If two or three parameter sets have been simultaneously selected for longer than 0.5 s, fault F041 is output. During the period where the status is not completely clear, the last clearly identified parameter set is used.

Software check, as to whether the parameter set selection remains the same during an optimization run. If a different parameter set is selected than that when the optimization runs was started, for longer than 0.5s, fault F041 is output.

A check is made per software as to whether ramp-function generator set 1 or 2 or 3 (parameter P303 to P314) are selected. If ramp-function generator parameter sets 2 and 3 are simultaneously selected for more than 0.5 s, error F041 is output. During the period that the status is not clear, the last clearly identified ramp-function generator parameter is used.

**Fault diagnostics memory**

Word 0

|   |   |
|---|---|
| 1 | Parameter set selection not clear                                 |
| 2 | The selected parameter set has changed during an optimization run |
| 3 | Ramp-function generator parameter set selection not clear         |

**Troubleshooting**

- Check parameters P761 to P766
- Check the status of the binary select inputs at parameter P010



**Possible fault causes**

- External short-circuit at the binary select inputs
- Incorrect activation of the binary select inputs
- Incorrect parameterization of the binary select inputs (P761 to P766)

**F042 Tachometer fault**

Active for operating statuses --, I, II

**Mode of operation**

Every 20 ms, a check is made as to whether  $\frac{\text{speed actual value}}{\text{EMF actual value}} > + 5\%$  (for P224 = 0xxx)  
 or  $\frac{-\text{speed actual value}}{\text{EMF actual value}} > + 5\%$  (for P224 = 1xxx)

The fault signal is activated if this is not the case for three consecutive checks.

The following is valid:

100% speed actual value = max. speed  
 100% EMF actual value = ideal average DC voltage at  $\alpha = 0$   
 i.e. when the thyristor bridge is fully gated.

The ideal average DC voltage at  $\alpha = 0$  is  $P071 * \frac{3 * \sqrt{2}}{\pi}$

The monitoring is only effective, if  $\text{EMF} > a \% \text{ of } P071 * \frac{3 * \sqrt{2}}{\pi}$

a is a percentage which can be set using parameter P357 (default setting, 10%).

Monitoring is only effective, if the armature current  $> 2\%$  of the rated converter DC current according to P072.

Note:

Before software release 2.00, instead of K149, speed controller actual value K165 was used for monitoring.

**Fault diagnostics memory**

Word 0 1 Defective tachometer  
 2 Incorrect tachometer or pulse encoder polarity

Word 1 Speed actual value (K149) under a fault condition

Word 2 EMF actual value (K287) under a fault condition

**Possible fault causes**

- Tachometer or pulse encoder cable interrupted
- Tachometer or pulse encoder cable incorrectly connected
- Pulse encoder supply failed
- Incorrectly set actual value polarity for the speed controller (P224)
- Incorrectly set armature circuit data (P110 and P111) (execute current controller optimization run)
- Rated supply range of the pulse encoder incorrectly set (plug-in jumpers XJ11, XJ12, XJ13), refer to Sections 6.8.1 and 6.9.

**F043 EMF for braking operation too high** **from SW2.00**

Active for operating statuses --, I, II

**Mode of operation**

This fault message is initiated, if the following 5 conditions are fulfilled for a requested torque direction change (M I or M II is to be selected):

- P082 = 0xx (error message parameterized and not alarm + field weakening)
- A possibly parameterized additional torque-free interval (P160 ≠ 0) has expired
- The parallel drive is ready for the new torque direction to be selected (if BEF60 is active)
- The absolute value of the armature current (K118) requested in the new torque direction, is >0.5% of P072
- The calculated firing angle (K101) for the armature current, requested in the new torque direction is > 165°.

Word 0 Calculated firing angle (aramture) before limiting (K101)

Word 1 Instantaneously measured EMF actual value (K287)

Word 2 EMF actual value (K287) under a fault condition

**Possible fault causes**

- Speed-dependent field weakening" (P082 = x0x) is not parameterized, although field weakening operation would have been necessary for the required maximum speed.  
Note:  
When motoring, for a firing angle  $\alpha_G = 30^\circ$  (rectifier stability limit P150), and low armature current, EMF values up to the peak value of the phase-to-phase supply voltage can be reached.
- Setpoint EMF for field weakening operation too high (parameter P101 set too high)
- Supply voltage interruption
- EMF controller or field current controller not optimized, which can lead to an excessive EMF when the drive accelerates.

**F046 Analog input, main setpoint (terminals 4 and 5) faulted** **from SW2.00**

Active for operating statuses ≤ o6

**Mode of operation**

This fault message is initiated, if P703 = 1x (4 to 20 mA input), and if an input current less than 3 mA flows.

**Possible fault causes**

- Main setpoint cable interrupted
- P703 incorrectly set

**F047 Analog input, select input 1 (terminal 6 and 7) faulted** **from SW2.00**

Active for operating statuses ≤ o6

**Mode of operation**

This fault message is initiated if P713 = 1x (4 to 20mA input) and if an input current less than 3 mA flows.

**Possible fault causes**

- input cable interrupted
- P713 incorrectly set

**F048 Fault in the measuring channel for digital pulse encoder speed sensing**

Active for all operating statuses

**Mode of operation**

1. Disturbance/noise on the encoder cables

The fault message is initiated, if 10 consecutive pulse encoder signal evaluations identify "direction of rotation change" at a speed  $\geq 48$  RPM.

2. Defective pulse encoder

The fault message is initiated, if for an EMF greater than internal threshold, over 10 consecutive pulse encoder signal evaluations, the characteristics of this signal appear erroneous (frequent speed change, edges too close together, encoder cable failure or short-circuit between two encoder cables).

Note:

With the tachometer operating correctly, at speeds in the vicinity of 0 direction of rotation change or short pulse clearances can be identified by gentle oscillation around the bright/dark transition on the speed encoder disk, therefore F048 is in this case only initiated

only initiated for  $EMK > 10\% \text{ of } P071 * \frac{3 * \sqrt{2}}{\pi}$

**Fault diagnostics memory**

Wort 0 1 Noise on the encoder cables  
2 Defective pulse encoder

**Possible fault causes**

- EMC interference on the pulse encoder signal (terminals 28 to 31)
- Defective pulse encoder
- Encoder cable interrupted
- Encoder cable short-circuit with respect to the supply voltage or another encoder cable
- P110 or P111 incorrectly set (the EMF is then incorrectly calculated)

**8.2.2.4 Start-up faults****F050 Optimization run not possible**

Active for all operating statuses

**Mode of operation**

A fault has occurred during an optimization run.

**Fault diagnostic memory and possible fault causes**

Word 0 1 Fault occurred during the optimization run for the current controller and pre-control for armature and field (selected using P051 = 25)  
2 Fault occurred during the speed controller optimization run (selected using P051 = 26)  
3 Fault occurred during the optimization run for field weakening (selected using P051 = 27)  
4 Fault occurred during the internal offset adjustments (selected using P051 = 22)  
5 Fault occurred during the optimization run for the friction- and moment of inertia compensation (was selected using P051 = 28) **from SW1.10**

**NOTE**

Although not always specified in the subsequent text, the contents of fault word 2 to 14 of P407 can provide more detailed information regarding the fault cause than that just provided in word 1 (refer to Section 10.2 for the significance of the specified connector numbers).

- Word 1 1 For  $\alpha = 30^\circ$  and  $EMF = 0$ , the armature current is too low.  
(Average armature current  $< 75\%$  of  $I_{A, motor}$  or  $< 75\%$  of  $I_{A, rated}$ )
- Word 2: Required current threshold (75% of P100 or P072),  
Word 3: K114, word 4: K301, word 5: K302, word 6: K303
- Possible cause: – Armature circuit interrupted  
– Very high ohmic load  
– P150 (Alpha G limit) was set too high
- 2 The armature circuit resistance (P110) cannot be determined.
- Possible cause: –  $R_A > 32.767\Omega$  (load is extremely high-ohmic, e.g. field supply from the armature terminals)  
– Armature current of 37.5% of P100 ( $I_{A, motor}$ ) not possible
- Possible remedy: – P100 ( $I_{A, motor}$ ) and P072 ( $I_{A, rated}$ ) must be parameterized with a higher value using the same factor (e.g. 10, 100) (note: this parameterization must be retained even after the optimization run has been repeated) at P110 and at P111, then the actual values divided by these factors are set during the optimization run.
- 3 For  $\alpha = 30^\circ$  and  $EMF = 0$ , the armature current crests are too small  
(Armature current peak value  $< 50\%$  of  $I_{A, motor}$  or  $< 50\%$  of  $I_{A, rated}$ )
- Word 2: Required current threshold  
Words 3 to 14: First 12 armature current sampling values after the firing pulse of the armature current crest (normalization: 818 = current acc. to P072)
- Possible cause: – Armature inductance too high (e.g. field supply from the armature terminal)  
– P150 (Alpha G limit) was set too high
- Possible remedy: – Reduce P100 ( $I_{A, motor}$ ) for the duration of this optimization run
- 4 The armature inductance (P111) cannot be defined from the sampling values from the armature current and supply voltage of the last-generated armature current crest.
- Possible cause: –  $L_A > 327.67\text{mH}$  (armature inductance too high)  
– P100 ( $I_{A, motor}$ ) far less than P072 ( $I_{A, rated}$ )  
– Armature short-circuited
- 5 Offset adjustment for the actual field current sensing not possible.  
(value found for P884, outside the permitted value range)
- Possible cause: – Fault in the actual field current sensing  
(defective gating board or A1600 electronics board)

- Words 1- 6 It is not possible to adjust the offset for the "main actual value" measured value channel (value found for P885 or P886, outside the permitted value range)
- Possible cause:    – Voltage  $< > 0$  at terminal block XT-100 to XT-103 (before P051 = 22: remove terminal block!)  
                           – Defective A1600 electronics board
- 7 The field resistance (P112) cannot be determined (the field current actual value does not reach the specified setpoint of 95% of P102 as a result of the P112 variation)
- Possible cause:    –  $R_A > 3276.7\Omega$   
                           – Fault in the field actual current sensing (defective gating board or A1600 electronics board)  
                           – The "enter standstill field" command is input (binary input function 56)
- 8 80% of the rated EMF ( $K289 = P101 - P100 * P110$ ) cannot be reached within 15 s (or the maximum of 3 set ramp-up times).
- Word 2: Required EMF threshold ( $0.8 * K289$ ),  
 Word 3: K286, Word 4: K117, Word 5: K119, Word 6: K265,  
 Word 7: K167, Word 8: K168, Word 9: K304, Word 10: K301,  
 Word 11: K302, Word 12: K303
- Possible cause:    – Ramp-up time set too low (P303, P307, P311)  
                           – P101 does not match the selected maximum speed ( $V_A$  at  $n_{max} < P101$ ) or P102 is parameterized too low  
                           – The command "ramp-function generator enable" = 0 (binary input function BEF9) or "ramp-function generator stop" = 1 (binary input function BEF10) is entered.
- 9 The field current control loop is not stable enough for field characteristic plotting. (the field current actual value deviates by more than 0.39% of  $P102 + 0.15\%$  of P073 from the setpoint, 30 s after an internal field current setpoint input)
- Word 2: Max. permitted field current setpoint- actual value difference  
 Word 3: Absolute value of the field current- setpoint- actual value difference,  
 Word 4: K265 (averaged over 4 values), Word 5: K265,  
 Word 6: Field current setpoint from the optimization run (K201),  
 Word 7: K268, Word 8: K304, Word 9: K117,  
 Word 10: Offset in the field current setpoint - or associated flux memory table  
 Word 11: K167, Word 12: K168
- Possible cause:    – Field current controller or field current pre-control either not optimized or poorly optimized (check P112, P253 to P256 and execute the current controller optimization run (P051 = 25))

Word 1: A<sub>H</sub> Field characteristic not uniform (i.e., in spite of the field current setpoint reduction, the flux value of this particular measured point, calculated from the EMF - and speed actual value, increases)

Word 2: Flux tabular value calculated from the EMF and speed (normalization: 20000 = rated (maximum) flux),

Word 3: Previous flux value (assigned to the next highest setpoint of the internal field current setpoint table)

Word 4: Offset in the field current setpoint - or associated flux memory table,

Word 5: EMF at rated field (K286, averaged over 90 cycles)

Word 6: EMF of this field weakening measured point (K286, averaged over 90 cycles),

Word 7:  $n_{act}$  at rated field (K166, averaged over 90 cycles),

Word 8:  $n_{act}$  of this field weakening measured point (K166, averaged over 90 cycles),

Word 9: K168, Word 10: K265,

Word 11: Field current setpoint from the optimization run (K201),

Word 12: K117

Absolute address, flux value: Word 4 + Word 13 + 4000H \* Word 14

Possible cause:

- High armature reactance and widely varying load during field characteristic plotting
- Field current controller or field current pre-control either not optimized or poorly optimized (check P112, P253 to P256, or execute current controller optimization run (P051 = 25))

B<sub>H</sub> A lower field current limit  $\geq 50\%$  of P102 ( $I_{F, motor}$ ) is entered. (thus, the minimum 9 field weakening measured points cannot be plotted).

Word 2, 4, 6, 8, 9, 10, 11, 12, 13 as for Word 1 = C<sub>H</sub>,

Word 3: K268,

Word 5: EMF from the previous field weakening measured point (K286 averaged over 90 cycles),

Word 7:  $n_{act}$  of the previous field weakening measured point (K166 averaged over 90 cycles)

Possible cause: P103  $\geq 50\%$  of P102, check P614.0x

C<sub>H</sub> The drive has reached the positive torque limit, although the specified field current setpoint is still  $\geq 50\%$  of P102 ( $I_{F, motor}$ ).

Word 2: Offset in the field current setpoint - or associated flux-memory table, where the setpoint limiting occurs,

Word 3: K119, Word 4: K167,

Word 5: EMF of this field weakening measuring point (K286 averaged over 90 cycles),

Word 6:  $n_{act}$  at the rated field (K166 averaged over 90 cycles),

Word 7:  $n_{act}$  of this field weakening measured point (K166, averaged over 90 cycles),

Word 8: K168, Word 9: K265,

Word 10: field current setpoint from the optimization run (K201),

Word 11: K117

Absolute address, flux value: Word 2 + Word 12 + 4000H \* Word 13

Possible cause:

- Armature current not steady, e.g., due to the high speed controller P gain P 225 (for drives with high integrating times) - a possible counter-measure is to parameterize a small speed actual value filtering P200 and re-execute the speed controller optimization run (P051 = 26)
- Check the torque limits

Word 1: D<sub>H</sub> The drive has reached the positive armature current limit, although the entered field current setpoint is still  $\geq 50\%$  of P102 ( $I_{F, motor}$ ).

Word 2 to word 13 as for word 1 = C<sub>H</sub>

Possible cause:

- Armature current not steady, e.g., due to the high speed controller P gain P 225 (for drives with high integrating times) - a possible counter-measure is to parameterize a low speed actual value filtering P200 and re-execute the speed controller optimization run (P051 = 26)
- Check the torque limits

E<sub>H</sub> The speed has changed by more than 12.5% for a constant speed setpoint, although the entered field current setpoint is still  $\geq 50\%$  of P102 ( $I_{F, motor}$ ).

Word 2 to word 13 as for word 1 = C<sub>H</sub>

F<sub>H</sub> The EMF setpoint is too low for a field characteristic plot  
 $EMF_{set} = V_A - I_{A, motor} * R_A = P101 - P100 * P110 < 10\%$  from  $1.35 * P071$   
 (e.g. P071 = 400 . . . minimum  $EMF_{set} = 54V$ ).

10<sub>H</sub> Field weakening operation is not permitted for operation without tachometer (P083 = 3).

11<sub>H</sub> The field current controller cannot be optimized, as the field time constant cannot be determined (the field current actual value does not decay to below  $0.95 * \text{initial value}$  within 100 field firing pulse cycles (1s at 50 Hz), or below  $0.8 * 0.95 * \text{initial value}$  within 200 field firing pulse cycles (2 s at 50 Hz).

Word 2: Field current threshold ( $0.95 * \text{initial value}$  or 80% of this value),  
 Word 3 to word 14: The last 12 field firing pulse-synchronous measured field current actual values K265 (word 3 is the furthest back in time)

Possible cause:

- Field inductance too high
- Fault in the field current actual value sensing (defective gating board or A1600 electronics board)
- Ratio P073/P102 is too high (if required change the field load resistors)

12<sub>H</sub> Field weakening range too high, i.e. when accelerating (with full field) to a speed setpoint of  $+ 10\% n_{max}$ , an  $|EMF| > 77\%$  of the setpoint EMF is obtained (P101 - P100 \* P110).

Word 2 to word 14 as for word 1 = 13<sub>H</sub>

Possible cause:

- Maximum speed incorrectly set
- Pulse encoder parameter incorrect (P140 to P143)
- Tachometer adaption parameter incorrect (P706, P708)
- Setpoint EMF incorrect (P101, P100, P110)
- An excessive load torque (positive or negative direction, e.g. from a hoist load), causes the drive to rotate - it is possible that an armature current - or torque limit has been parameterized too low.

Word 1 13<sub>H</sub> Within 3 minutes (or the maximum of 3 selected ramp-up times), a steady-state actual speed of + 10%, + 20%, + 30% ... or + 100% of the maximum speed cannot be reached in speed-controlled operation (the speed setpoint-actual value difference, averaged over 90 firing cycles, must be  $< 0.1\% n_{\max}$  over a specific time).

Word 2: K167, word 3: K168, word 4: K286, word 5:  $0.7692 * K289$ ,

Word 6: K117, word 7: K119, word 8: K131, word 9: K265,

Word 10: K304, word 11: K301, word 12: K302,

Word 13: K167, averaged over 90 firing cycles,

Word 14: K117 (for P170 = x0) or K142 for (P170 = x1) averaged over 90 firing cycles

- Possible cause:
- The ramp-up time is set too low (P303, P307, P311)
  - Drive has stalled
  - An excessive load torque (positive or negative direction, e.g. hoist load), causes the drive to move, possibly an armature current limit/torque limit is parameterized too low
  - Poor speed controller setting (P225, P226, P228), or the speed controller is parameterized as pure P controller or with droop
  - An inhibit filter (P201, P202 or P203, P204) is switched-in (for SW1.10, this can result in a steady-state deviation between the filter input and filter output).
  - The "ramp-function generator enable" command was entered for 0 (binary input function 9) or ramp-function generator stop" = 1 (binary input function 10)

14<sub>H</sub> Current limit too low (for word 0 = 2,  $< 30\%$  or  $45\%$  of P100 ( $I_{A, motor}$ ) + the armature current required for zero speed, for word 0 = 5  $< 20\%$  of P100 ( $I_{A, motor}$ ) + the armature current required for a steady-state speed of 10% of the maximum speed.

Word 2: For word 0 = 2, current for  $n_{act} = 0$ , for word 0 = 5, current (K117) or torque (K142) for  $n_{act} = 10\% n_{\max}$ , averaged over 90 firing cycles

Word 3: for word 0 = 2  $\Rightarrow 30\%$  or  $45\%$  from P100 + word 2,  
for word 0 = 5  $\Rightarrow 20\%$  from P100 + word 2,

Word 4: K131, word 5: K265, word 6: K167

15<sub>H</sub> Field weakening range too wide ( $n_{act} < + 7\% n_{\max}$  results in  $|EMF| > 54\%$  reference EMF)

( $n_{act}$  is averaged over 6 cycles, reference EMF =  $K289 = P101 - P100 * P110$ )

Word 2: K167 (averaged over the last 6 values), word 3: K286,

Word 4:  $0.54 * K289$  for word 0 = 2 (or  $0.77 * K289$  for word 0 = 5),

Word 5: K117 (delayed by 3 cycles),

Word 6: K119, word 7: K131, Word 8: K265,

Word 9 to 14: The last 6 armature firing pulse-synchronous measured speed actual values K167 (word 9 lies the farthest back in time)

- Possible cause:
- Maximum speed incorrectly set
  - Pulse encoder parameter incorrect (P140 to P143)
  - Parameter for tachometer adaption incorrect (P706, P708)
  - Reference EMF incorrect (P101, P100, P110)
  - Caution:  
Even an absolute negative speed actual value which is greater can result in  $|EMF| > 54\%$  reference EMF.



- Word 1 16<sub>H</sub> Word 0 = 2: With an accelerating current of 20% or 30% of P100 ( $I_{A, motor}$ ) + the armature current required for zero speed or  
 Word 0 = 5: With an accelerating current with a current magnitude required for a steady-state speed of 10% of the maximum speed + 20% of P100 ( $I_{A, motor}$ ), cannot be reached within 45 s (at 50 Hz) + 7% of the maximum speed (speed actual value averaging over 6 firing cycles).  
 Words 2 to 14 as for word 1 = 15<sub>H</sub>
- Possible cause:     – Excessive moment of inertia  
                           – Drive is stalled, load torque is either very dependent on the speed, or too high  
                           – "Active" load attempts to keep a certain speed
- Possible remedy:   – Increase P100 for the duration of the optimization run, to increase the accelerating current, specified during the optimization run (at the speed controller optimization run, word 0 = 2, max. 45% of  $I_{A, motor}$  (+ armature current for speed 0) is entered as armature current setpoint,  $I_{A, motor}$  (P100) can therefore be increased to a maximum of 220 % of the value, without exceeding 100%  $I_{A, motor}$  during the optimization run).
- 17<sub>H</sub> Word 0 = 2: With an accelerating current of 20% or 30% of P100 ( $I_{A, motor}$ ) + the armature current required for zero speed or  
 Word 0 = 5: With an accelerating current having a magnitude of the current required for a steady-state speed of 10% of the maximum speed (+ 20% of P100 ( $I_{A, motor}$ )) cannot reach + 13% of the maximum speed within 90 s (at 50 Hz) (speed actual value averaging over 6 firing cycles), or 100% of the reference EMF.  
 Words 2, 3, 5 to 14 as for word 1 = 15<sub>H</sub>  
 Word 4: K289
- Possible cause:     as for word 1 = 16<sub>H</sub>
- Possible remedy:   as for word 1 = 16<sub>H</sub>
- 18<sub>H</sub> The actual speed does not fall below + 2% of the maximum speed or below the speed threshold  $n_{min}$  according to P370, within  
 2 minutes for word 0 = 2 or  
 10 minutes for word 0 = 3 or  
 11 or 2 minutes for word 0 = 5
- Word 2: K167  
 Word 3: Maximum time which is exceeded in 20 ms units
- Possible cause:     Single-quadrant drive coasts down too slowly
- 19<sub>H</sub> The average armature current, required for the speed range from + 7% to approx. + 13% of the maximum speed, to cover the friction- or steady-state load torque, cannot be calculated.
- Word 2: Calculated "friction current" (8000 h signifies overflow)  
 Word 3: Measuring time (cycles) for accelerating from  $n_1$  to  $n_2$  with  $I_{12}$   
 Word 4: Average armature current  $I_{12}$  in the range  $n_1$  to  $n_2$   
 Word 5: Speed difference ( $n_2 - n_1$ )  
 Word 6: Measuring time (cycles) for accelerating from  $n_3$  to  $n_4$  with  $I_{34}$   
 Word 7: Average armature current  $I_{34}$  in the range  $n_3$  to  $n_4$   
 Word 8: Speed difference ( $n_4 - n_3$ )

- Possible cause:
- Drive with very low friction or very low integrating time, and as a result, calculation inaccuracies during evaluation as a result of the short measuring time
  - Noisy speed actual value
  - High moment of inertia which is coupled to the drive through a long shaft with high torsion, possibly through a coupling/gearbox with considerable play
- Possible remedy:
- Reduce P100 for the duration of the optimization run, to reduce the specified accelerating current during the optimization run, and thus increasing the measuring time.

Word 1: 1A<sub>H</sub> Load torque too large ( $n_{set} = 0\% n_{max}$  results in  $n_{act} \geq 40\% n_{max}$ )  
(Speed actual value is averaged over 90 firing cycles, speed monitoring to  $\geq 40\% n_{max}$ , starts only 1 s after speed setpoint input  $n_{set} = 0$ )

Word 2: K167, word 3: K168, word 4: K287, word 5: K132, word 6: K117,  
Word 7: K119, word 8: K131, word 9: K265, word 10: K304, word 11: K301,  
Word 12: K302,  
Word 13: K167, averaged over 90 firing cycles  
Word 14: K117, averaged over 90 firing cycles

- Possible cause:
- Excessive load torque (in the positive or negative direction, e.g. a hoist load), causes the drive to rotate (the speed controller parameters are parameterized during this optimization run according to the factory setting)
  - An armature current- or torque limit has been parameterized too low (maybe the motor field does not establish itself quickly enough to provide full field, so that the motor torque is too low at the start).
  - Maximum speed incorrectly set
  - Pulse encoder parameters incorrect (P140 to P143)
  - Incorrect parameters for tachometer adaption (P706, P708)

1B<sub>H</sub> Load torque too large ( $n_{set} = 0\% n_{max}$  results in  $|EMF| \geq 100\%$  reference EMF)  
(EMF monitoring to  $\geq (P101 - P100 * P110)$  first starts 1 s after speed setpoint input  $n_{set} = 0$ )

Words 2 to 14 as for word 1 = 1A<sub>H</sub>

- Possible cause:
- as for Word 1 = 1A<sub>H</sub>
  - Reference EMF incorrect (P101, P100, P110)

1C<sub>H</sub> A steady-state actual speed of 0% of the maximum speed cannot be achieved within 30 s in speed controlled operation (the speed setpoint-actual value difference, averaged over 90 firing cycles, must be a total of 4 s long  $< 1.0\% n_{max}$ )

Words 2 to 14 as for word 1 = 1A<sub>H</sub>

- Possible cause: as for word 1 = 1A<sub>H</sub>

1D<sub>H</sub> The armature inductance (P111) is greater than 327.67mH  
(when using the integrating method - for low current ripple)

- Possible cause: - e.g. field supply from the armature terminals

- Possible remedy: as for word 1 = 2 (P100 and P072 are parameterized with a higher value using the same factor K)

The actual value of  $L_A$  can be calculated as follows ( $I_{A, rated}$  is the rated converter armature DC current, for which the converter load resistors are actually dimensioned)  $\Rightarrow$  required factor  $K > (L_A \text{ in mH} / 327.67\text{mH})$ :

$$L_A \text{ in mH} = \frac{(\text{Word 2} + 65536 \text{ word 3}) * P071}{4171 * \text{word 5} * I_{A, rated}}$$

**F051 Optimization run with permanent memory inhibit not possible**

Active for all operating statuses

**Mode of operation**

If an optimization run is started, a check is made as to whether it is permitted to store parameter values in the EEPROM (check as to whether parameter P053 = x1).

**Possible fault causes**

- Parameter P053 = x0

**Remedy:**

- Acknowledge fault
- Switch-off electronics power supply
- Set plug-in jumper XJ1 on the A1600 electronics board into position 1-2
- Switch-on power
- Set P053 = x1
- Re-start optimization run

**F052 Optimization run externally interrupted**

Active for all operating statuses

**Mode of operation**

This fault signal is initiated, if ON status is no longer available during an optimization run (status I, II or --) (thus, at each FAULT), or if FAST STOP, SHUTDOWN or STANDSTILL EXCITATION are input. The optimization run is terminated. Only those parameters, which were optimized before the fault was initiated, are changed.

**Note:**

From software release 2.00, when SHUTDOWN is entered, this fault message is not triggered, if the field weakening optimization run, is interrupted after the first field weakening measuring point has been plotted, or if the optimization run for the friction- and moment of inertia compensation is interrupted after the measuring point at 10% of the maximum speed has been determined. In these cases, it is possible to interrupt using SHUTDOWN, to be able to complete the optimization run with limited travel, in several stages (using repeated new start).

**Fault diagnostics memory**

- |        |   |  |                    |
|--------|---|--|--------------------|
| Word 0 | 1 | Fault occurred during the optimization run for current controller and pre-control for the armature and field (controller selected using P051 = 25) |                    |
|        | 2 | Fault occurred during the optimization run for the speed controller (selected using P051 = 26)   |                    |
|        | 3 | Fault occurred during the optimization run for field weakening (selected using P051 = 27)  |                    |
|        | 5 | Fault occurred during the optimization run for the friction- and moment of inertia compensation (was selected using P051 = 28)                     | <b>from SW1.10</b> |
| Word 1 | 1 | Terminated, because RUN status <u>no</u> longer available  |                    |
|        | 2 | Terminated, because FAST STOP was input (speed controller setpoint = 0)  |                    |
|        | 3 | Terminated, because SHUTDOWN was input (ramp-function generator setpoint = 0)  |                    |
|        | 4 | Terminated, because STANDSTILL EXCITATION was input  |                    |

**F055 Field characteristic was not recorded**

Active for operating statuses --, I, II

**Mode of operation**

The fault message is initiated, if "speed-dependent field weakening" is selected with P082 = x1x, or "closed-loop torque control", using P170 = x1, however no "valid field characteristic was plotted" (P117 = 0).

**Possible fault causes**

- Optimization run for field weakening (P051 = 27) has still not been executed.

**F056 Important parameters not set**

Active for operating statuses ≤ 06

**Mode of operation**

The fault signal is activated if specific parameters are still set to 0.

**Fault diagnostics memory**

Word 0 1 P083 still at 0  
2 P100 still at 0.0  
3 P102 still at 0.00 (fault message only for P082 ≠ xx0)

**Possible fault causes**

- Speed controller actual value still not set at P083
- Rated motor armature current still not set at P100
- Rated motor field current still not set at P102

**F057 Option selection incorrect**

Active for operating statuses ≤ 06

**Mode of operation**

This fault signal is activated if a parallel SITOR set is connected, but parameter P074 was set to 0x (parallel SITOR set not available).

**Possible fault causes**

- Parallel SITOR set present, but not selected

**F058 Parameter settings not consistent**

Active for operating statuses  $\leq 06$

**Mode of operation**

A check is made per software as to whether associated values are set in mutually-dependent parameters.

**Fault diagnostics memory**

- Word 0
- 1 The nominal input voltage value for the main actual value, set at parameter P706, lies outside the range specified by parameter P708
  - 2 Parameters were incorrectly set for the speed-dependent current limiting  
from SW2.00  
(the following must be valid:  $P105 > P107$  ( $I_1 > I_2$ ) and  $P104 < P106$  ( $n_1 < n_2$ ))
  - 3 Field characteristic not monotone
  - 4 The first threshold for the speed controller P gain adaption set at parameter P556 lies above the second threshold set at parameter P559
  - 5 The first threshold for the speed controller integral-action time adaption set at parameter P557 lies above the second threshold set at parameter P560
  - 6 The first threshold for the speed controller droop factor adaption, set at parameter P558, lies above the second threshold, set at parameter P561
  - 7 If  $P083 = 1$  (analog tachometer), then P708 cannot be 0x (main actual value not used)
  - 8 If  $P083 = 2$  (pulse encoder), then P140 cannot be 0 (no pulse encoder present)
  - 9 If  $P083 = 3$  (EMF control), then P082 cannot be x1x (field weakening operation)
  - A P090 (supply voltage stabilizing time)  $\geq$  P086 (time for automatic restart)
  - B P090 (supply voltage stabilizing time)  $\geq$  P089 (waiting time in status o4 and o5)
  - C P769 is set to 1 (switch-on, shutdown and crawl acts as pushbutton), although no binary select input is parameterized as shutdown button (BEF2)  
from SW2.00

**F059 Function selection for G-SST0 and G-SST1 incorrect**

Active for all operating statuses

**Mode of operation**

A check is made per software, as to whether the function selection for the serial basic converter interfaces is correct. The check is made in all operating statuses, as soon as the value mode has been exited during parameterization.

**Possible fault causes**

- The one's digit of parameters P780 and P790 cannot be the same, i.e. the same functions cannot be simultaneously selected at both interfaces.  
Exception: Setting 2 (USS protocol)

**F060 Modified software version** **from SW1.10**

Active directly after the supply voltage is applied to electronics board A1600

**Mode of operation**

When the A 1600 electronics board is switched-on, the EPROM software version is compared with the version number in the EEPROM (permanent memory).

**Fault diagnostics memory**

Word 0 Version number of the actual EPROM

Word 1 Valid version number before the A1600 electronic board was switched-off for the last time

**Possible fault cause**

- Software board A 1630 was replaced; the same procedure as for software replacement must be carried-out (refer to Section 11.1)

**8.2.2.5 Fault messages from the thyristor check function**

Active for operating statuses o3

This fault message group can only occur, if the thyristor check function is activated via parameter P860.

**Mode of operation**

A software check is made as to whether all thyristors can block and be triggered.

**Possible fault causes**

The appropriate thyristor module should be replaced if "thyristor defective" or "thyristor unable to block" is signaled. Although temporary thyristor failure is possible, re-occurring fault message indicates a possible problem in another area.

**Possible causes of destruction:**

- Interruption in the snubber circuitry
- Current controller and pre-control not optimized (excessive current spikes)
- Cooling not sufficient (e.g. fan doesn't run, ambient temperature too high, incorrect fan rotation of direction (incorrect phase sequence), air intake too low, heatsink dirty)
- Excessive supply voltage spikes
- External short-circuit or ground fault (check armature circuit)

If "thyristor cannot be triggered" is signaled, this is generally caused by a gating circuit fault, and not be a defective thyristor.

**Possible causes:**

- Gating pulse cable to the associated thyristor interrupted
- Ribbon cable X101 incorrectly inserted or interrupted (and ribbon cable X150 for SITOR sets connected in parallel)
- Defective electronics or gating board
- Internal interruption of the gate conductor in the thyristor module

The firing cables and associated thyristors should always be identified using the appropriate equipment circuit diagram (refer to Section 6.4, power connections).

for converters > 600A, the following is valid:

SITOR blocks A11 to A16 correspond to modules V1 to V6 of the 30A to 600A units.

- F061 Defective thyristor (short-circuit in module V1)**  
(for the 15 A converter: V1 or V4)
- F062 Defective thyristor (short-circuit in module V2)**  
(for the 15 A converter: V2 or V5)
- F063 Defective thyristor (short-circuit in module V3)**  
(for the 15 A converter: V3 or V6)
- F064 Defective thyristor (short-circuit in module V4)**  
(for the 15 A converter: V4 or V1)
- F065 Defective thyristor (short-circuit in module V5)**  
(for the 15 A converter: V5 or V2)
- F066 Defective thyristor (short-circuit in module V6)**  
(for the 15 A converter: V6 or V3)
- F068 Armature circuit ground fault** **from SW2.00**
- Fault diagnostics memory  
Word 1 Firing angle, at which current flowed to ground (K101)
- F069 I = 0 signal defective**
- Possible fault causes
- Defective A1600 electronics board
- F071 Thyristor unable to be triggered (X11)**
- F072 Thyristor unable to be triggered (X12)**
- F073 Thyristor unable to be triggered (X13)**
- F074 Thyristor unable to be triggered (X14)**
- F075 Thyristor unable to be triggered (X15)**
- F076 Thyristor unable to be triggered (X16)**
- F077 2 or more thyristors (MI) unable to be triggered**
- Possible fault causes
- Armature circuit interrupted

- F081 Thyristor unable to be triggered (X21)**
- F082 Thyristor unable to be triggered (X22)**
- F083 Thyristor unable to be triggered (X23)**
- F084 Thyristor unable to be triggered (X24)**
- F085 Thyristor unable to be triggered (X25)**
- F086 Thyristor unable to be triggered (X26)**
- F087 2 or more thyristors (MII) unable to be triggered**

**Possible fault causes**

- Parameter P074 incorrectly set

- F091 Thyristor unable to block (X11 or X21)**
- F092 Thyristor unable to block (X12 or X22)**
- F093 Thyristor unable to block (X13 or X23)**
- F094 Thyristor unable to block (X14 or X24)**
- F095 Thyristor unable to block (X15 or X25)**
- F096 Thyristor unable to block (X16 or X26)**

### **8.2.2.6 Internal faults**

#### **F100 Illegal microprocessor status**

Active for all operating statuses

**Mode of operation**

Internal microprocessor hardware monitors the microprocessor for illegal operating statuses.

**Possible fault causes**

- Defective A1600 electronics board
- Excessive EMC interference present (e.g. as a result of undamped contactors, unscreened cables, loose screen connections)



**F101 Watchdog timer has initiated a reset**

Active for all operating statuses

**Mode of operation**

An internal microprocessor hardware counter monitors as to whether the program for calculating the gating pulses is executed, at least approximately every 14 ms (it is executed on the average, every 2.7 to 3.3 ms). If this is not the case, the counter initiates a reset. F101 is subsequently output.

**Possible fault causes**

- Defective A1600 electronics board
- Excessive EMC interference present (e.g. as a result of undamped contactors, unscreened cables, loose screen connections)

**F102 EEPROM fault**

Active for all operating statuses

**Mode of operation**

The correct functioning of the EEPROM module on the A1600 electronics board is monitored per software.

(Type: X28C64, 8192 bytes)

The EEPROM has values, which may not be lost at voltage failure (i.e., the parameter values and process data which must be stored in a non-volatile fashion). Immediately after the electronics supply has been switched-on, the contents of the EEPROM are copied into the RAM. All programs only access this parameter image. This parameter image is also the only image changed via the parameterizing device. A program continuously modifies the EEPROM contents to follow the contents of the RAM, and more specifically, every 20 ms, 1 byte is checked and for non-equivalence between the values in the RAM and EEPROM, the RAM cell value is written into the appropriate EEPROM cell. At the same time, the written value is stored in an additional RAM cell. The EEPROM requires a maximum of 10 ms, until it has processed the value which was written into it, and during this time, it can neither be written into or read-out of. The previously written memory cell is read from the EEPROM, and compared with the additional stored cell, in the next background program cycle (i.e. after approx. 20 ms). F102 is activated if they don't match.

Using P053 = x0, the parameter value is not stored in the EEPROM (permanent memory inhibit active). Fault message F102 is also suppressed in this case.

**Troubleshooting**

- Determine the position of plug-in jumper XJ1 on the A1600 electronics board
- Determine the value of parameter P053

**Possible fault causes**

- Defective EEPROM
- An attempt was made to change a parameter, although the hardware write protection is activated (plug-in jumper XJ1 on the A1600 electronics board in position 2-3), and the software write protection is not activated (P053 = x1).

**F103 Parameter value outside the permitted range**

Active for all operating statuses

**Mode of operation**

Immediately after the electronics power supply has been switched-on, the parameter values from the EEPROM are loaded into the operating memory (RAM). A check is simultaneously made, as to whether the values lie within their permissible range. F103 is output if this is not the case. The relevant parameter value is limited.

Word 0 Number of the erroneous parameter

Word 1 Index of the erroneous parameter

Word 2 Erroneous parameter value

**Possible fault causes**

- "Reset to default" was never executed with this software (e.g. after software replacement)
- Excessive EMC interference present (e.g. as a result of undamped contactors, non-screened cables, loose screen connections)

Remedy:

Acknowledge fault, reset to default and re-commission the drive!

**F104 Incorrect EEPROM check sum**

Active for all operating statuses

**Mode of operation**

A check sum of the parameter values stored in the EEPROM is cyclically generated, and compared with a check sum, which is saved with the non-volatile process data. F104 is output if the last calculated check sum does not coincide with the saved check sum.

**Possible fault causes**

- Defective EEPROM
- The hardware write protection (plug-in jumper XJ1 on board A1600) was changed-over with the converter switched-on.
- A parameter value was changed with active hardware permanent memory inhibit (plug-in jumper XJ1 on electronics board A1600 in position 2-3), but inactive software inhibit (P053 = x1).
- Parameter P053 was changed with active hardware permanent memory inhibit (plug-in jumper XJ1 on electronics board A1600 in position 2-3), and previously activated software inhibit (P053 = x0). The software always attempts to back-up P053 in the EEPROM.
- Excessive EMC interference present (e.g. as a result of undamped contactors, non-screened cables, loose screen connections)
- "Reset to default" was never executed with this software (e.g. after software replacement)

Remedy:

Acknowledge the fault, reset to default setting and re-commission the drive!

Check the noise suppression measures and if required improve.

If F104 still occurs even with adequate noise suppression measures, replace electronics board A1600.

**F105 Defective RAM**

Active in all operating statuses

**Mode of operation**

The correct functioning of the RAM module (data memory) on electronics board A1600 is monitored per software.

A specific bit pattern is written into the complete RAM immediately after the electronics power supply is switched-on. It is then read again. F105 is output if the data contents don't match.

**Possible fault causes**

- Defective RAM (replace A1600 electronics board)

**F107 Internal buffer overflow**

Active in all operating statuses

**Mode of operation**

The various software buffers are monitored per software.

**Possible fault causes**

- Excessive EMC interference (e.g. as a result of undamped contactors, non-screened cables, loose screen connections)

**F109 Defective supply voltage sensing**

Active for operating statuses  $\leq 04$

**Mode of operation**

An offset  $> 5\%$  was determined during the attempt to adjust the supply voltage sensing offset per software.

**Possible fault causes**

- Defective voltage path on the gating board (A1601 or A1603 or A1604) or on the electronics board (A1600)

**F110 Converter cooling faulted**

Active for operating statuses  $\leq 04$

**Mode of operation**

A check is made as to whether a thermal contact is open, and whether the fan speed of both fans lies in the range between 2160 RPM and 3300 RPM. The monitoring function is activated 3 s after the drive is in operating status  $\leq 04$ .

**Fault diagnostics memory**

- Word 0
- 1 Thermal contact open
  - 2 Fan not running (only for 640A to 1200A converters)
  - 3 Fan running too slow or too fast (only for 640A to 1200A converters)

**Possible fault causes**

- For the 15A converter: Defective A1608 board
- For 30A to 140A converters: Missing short-circuit jumper X6 on board A1601
- For 200A to 600A converters:
  - Thermal contact open
  - Thermal contact not connected at X6 on board A1601
  - Dirty heatsink
  - Heat accumulation
  - Incorrect fan direction of rotation (incorrect phase sequence)
- For 640A to 1200A converters:
  - Converter fan not connected to the supply
  - Defective converter fan
  - Incorrect fan direction of rotation (incorrect phase sequence)

**F111 Defective measuring channel for the main setpoint (terminals 4 and 5)**

Active in all operating statuses

**Mode of operation**

Hardware monitoring of the measuring circuit

**Possible fault causes**

- Defective A1600 board
- "Main setpoint" input voltage greater than approx. 11.3 V (measuring circuit saturated)

**F112 Defective measuring channel, select input 1 (terminals 6 and 7)**

Active in all operating statuses

**Mode of operation**

Hardware monitoring of the measuring circuit

**Possible fault causes**

- Defective A1600 board
- "Select signal 1" input voltage greater than approx. 11.3 V (measuring circuit saturated)

**F113 Defective measuring channel for the main actual value (terminals 101 to 104)**

Active for operating statuses  $\leq o6$

**Mode of operation**

Hardware monitoring of the measuring circuit

**Possible fault causes**

- Defective A1600 board

### 8.2.2.7 Fault messages from the motor sensor system

#### **F115 Brush length too low**

Active for operating statuses  $\leq$  o3

##### **Mode of operation**

For parameter P145 = xxx2 (binary sensing of the brush length):  
Fault message with log "0" signal at terminal strip XM, terminal 211.

For parameter P145 = xxx3 (analog sensing of the brush length):  
Fault message for brush length  $\leq$  12mm, or if the voltage at terminal XM, terminal 202  $<$  1.7V.

##### **Possible fault causes**

- For parameter P145 = xxx2  
Brush length sensor responded or sensor cable interrupted
- For parameter P145 = xxx3  
Brush length  $\leq$  12mm or sensor cable interrupted

#### **F116 Poor bearing condition**

Active for operating statuses  $\leq$  o6

##### **Mode of operation**

For parameter P145 = xx2x:  
Fault message for a log "1" signal at terminal strip XM, terminal 212.

##### **Possible fault causes**

- Bearing condition sensor responded

#### **F117 Air flow monitoring**

Active for operating statuses  $\leq$  o6

##### **Mode of operation**

For parameter P145 = x2xx:  
Fault message, if a log "0" signal is present at terminal strip XM, terminal 213 for at least 40s.

##### **Possible fault causes**

- The fan monitoring sensor has responded or the sensor cable is interrupted

**F118 Motor overtemperature (binary sensing)**

Active for operating statuses ≤o6

**Mode of operation**

For parameter P145 = 2xxx:

Fault message for a log "0" signal at terminal strip XM, terminal 214.

**Possible fault causes**

- The thermal switch for motor temperature monitoring has responded or the sensor cable is interrupted

**F119 Motor overtemperature (analog sensing)**

Active for operating statuses --, I, II

**Mode of operation**

For parameter P146 = 1 or 2:

The fault message is initiated if the motor temperature reaches or exceeds the value selected using parameter P148.

For parameter P146 = 4, 6, 8 or 10:

The fault message is initiated, if the motor temperature reaches or exceeds the response value of the selected PTC.

**8.2.2.8 External faults**

**F121 Fault signal at terminal 39**

Active for all operating statuses

**Mode of operation**

The fault signal is available for a time which exceeds the time set using parameter P767.

**F122 Fault signal at terminal 40**

Active for all operating statuses

**Mode of operation**

The fault signal is available for a time which exceeds the time set using parameter P767.

**F123 Fault signal at terminal 41**

Active for all operating statuses

**Mode of operation**

The fault signal is available for a time which exceeds the time set using parameter P767.

**F124 Fault signal at terminal 42**

Active for all operating statuses

**Mode of operation**

The fault signal is available for a time which exceeds the time set using parameter P767.

**F125 Fault signal at terminal 43**

Active for all operating statuses

**Mode of operation**

The fault signal is available for a time which exceeds the time set using parameter P767.

**F126 Fault signal at terminal 36**

Active for all operating statuses

**Mode of operation**

The fault signal is available for a time which exceeds the time set using parameter P767.

**F128 to 255 Technology board fault**

**from SW1.10**

Active for all operating statuses

**Mode of operation**

Faults signaled from the technology board, are indicated, as for all other faults, using their fault number. If several faults are simultaneously signaled in the PT fault channel, the fault number, entered first in the buffer, is displayed. Possible additional fault numbers can be seen in the fault diagnostics memory.

**Fault diagnostics memory**

Word 0 Number of occurred faults (can exceed 3)

Word 1 Fault number 1

Word 2 Fault number 2

Word 3 Fault number 3

**Possible fault causes**

– Technology board fault

### 8.2.3 Acknowledging fault messages

Procedure for acknowledging fault messages:

- The fault message is acknowledged by
  - Depressing the SELECT key on the simple operator control panel or
  - Depressing the R key on the converter operator control panel, or
  - A positive going edge at a binary select input, which is assigned the "fault acknowledgement" (BEF5) function
  - A positive edge at bit 7 of control word STW (if P640 is appropriately parameterized)
  - A positive edge at a bit of the freely-definable control word STWF, which is assigned the function "fault acknowledgement" (BEF5) (if P641 and P642 are appropriately parameterized)

The drive goes into the "switch-on inhibit" operating status (o8) by acknowledging the fault message, if "switch-on" is present, and into the "wait for switch-on" operating status (o7) if "shutdown" is present.

The binary output function "fault" goes HIGH, and bit 3 of ZSW, LOW (i.e. no fault).

- Input "shutdown"

The "switch-on inhibit" status (o8) is in this case exited.

### 8.2.4 Disabling/activating monitoring functions

Monitoring functions, which are to be disabled, are entered in parameter P850.xx in any sequence (i.e. under any index). Indices of P850.xx which are not used should be left at 0. Several monitoring functions (specifically, F007, F028, F030 to F037), are already entered, in the factory, into parameter P850, and are thus disabled. If these are to be activated, the appropriate P850.xx must be set to 0.

Example: F042 (tachometer cable interrupted) is to be disabled  
→ P850.11 (or any P850.xx, which is 0) should be set to 42

Example: F035 (stall protection) is to be activated  
→ set P850.07 to 0 (no other P850.xx can be 35!)

## 8.3 Alarms

When one or several alarms occurs:

- The binary output function "alarm" (BAF24) is set to LOW (select function), bit 7 of status word ZSW (K325) is set to 1.
- The alarm is displayed by the flashing "ST" LED on the electronics board (A1600), or on the converter operating control panel by the flashing "FAULT" LED.  
Flash frequency: Approx. 1 Hz (50 ms lit, 50 ms dark)



### 8.3.1 Alarm displays

The actual alarms are indicated using parameters P049 and P050.

#### Alarms W00 to W14 (= K331)

P049 display:

at the simple operator control panel

|   |   |    |    |    |    |    |   |
|---|---|----|----|----|----|----|---|
| 0 | 1 | 2  | 3  | 4  | 5  | 6  | 7 |
| 8 | 9 | 10 | 11 | 12 | 13 | 14 |   |

at the converter operator control panel

|    |    |      |    |    |   |         |   |
|----|----|------|----|----|---|---------|---|
|    |    | P049 |    |    |   | Warning | 1 |
| 0  | 1  | 1    | 1  | 1  | 1 | 1       | 1 |
| 14 | 13 | 12   | 11 | 10 | 9 | 8       | 7 |

The meaning of the individual alarms can be taken from the alarm list, Section 8.3.2!

Segment lit or "1" ... alarm present

Segment dark or "0" ... alarm not present

Segment 0 on the simple operator control panel or bit 0 on the converter operator control panel corresponds to alarm W00.

#### Alarms W16 to W30 (= K332)

P050 display:

on the simple operator control panel

|    |    |    |    |    |    |    |    |
|----|----|----|----|----|----|----|----|
| 16 | 17 | 18 | 19 | 20 | 21 | 22 | 23 |
| 24 | 25 | 26 | 27 | 28 | 29 | 30 |    |

on the converter operator control panel

|    |    |      |    |    |    |         |    |
|----|----|------|----|----|----|---------|----|
|    |    | P050 |    |    |    | Warning | 2  |
| 0  | 1  | 1    | 1  | 1  | 1  | 1       | 1  |
| 30 | 29 | 28   | 27 | 26 | 25 | 24      | 23 |

The meaning of the individual alarms can be taken from the alarm list, Section 8.3.2!

Segment lit or "1" ... alarm present

Segment dark or "0" ... alarm not present

Segment 16 on the simple operator control panel or bit 16 on the converter operator control panel corresponds to alarm W16.

When using the converter operator control panel, in the OPERATING DISPLAY mode, parameters P049 and P050, and thus the current alarms, can be indicated by depressing the R key. In this case, a changeover is automatically made to the two-value display (all possible alarms at one glance).

Display on the converter operator control panel after depressing the R key.

|   |    |    |    |    |    |    |    |    |    |    |    |    |    |    |    |
|---|----|----|----|----|----|----|----|----|----|----|----|----|----|----|----|
| W | 14 | 13 | 12 | 11 | 10 | 9  | 8  | 7  | 6  | 5  | 4  | 3  | 2  | 1  | 0  |
| W | 1  | 1  | 1  | 1  | 1  | 1  | 1  | 1  | 1  | 1  | 1  | 1  | 1  | 1  | 1  |
| W | 1  | 1  | 1  | 1  | 1  | 1  | 1  | 1  | 1  | 1  | 1  | 1  | 1  | 1  | 1  |
|   | 30 | 29 | 28 | 27 | 26 | 25 | 24 | 23 | 22 | 21 | 20 | 19 | 18 | 17 | 16 |

The OPERATING DISPLAY is re-selected by depressing the R key again.

The PARAMETERIZATION mode is selected by depressing the P key.

### 8.3.2 Alarm list

#### **W01 Motor overtemperature**

##### **Mode of operation**

The alarm is initiated, if the calculated  $I^2t$  value reaches a magnitude, which corresponds to the final temperature at 100% of the rated motor armature current.

#### **W02 Brush length**

##### **Mode of operation**

For parameter P145 = xxx1 (binary brush length sensing):

Alarm for log "0" signal at terminal strip XM, terminal 211 (when the brush length sensor responds, or the sensor cable is interrupted).

For parameter P145 = xxx3 (analog sensing of the brush length):

Alarm when the brush length  $\leq 14\text{mm}$ .

#### **W03 Bearing condition**

##### **Mode of operation**

For parameter P145 = xx1x:

Alarm for log "1" signal at terminal strip XM, terminal 212 (when the bearing condition sensor responds).

#### **W04 Motor fan**

##### **Mode of operation**

For parameter P145 = x1xx:

Alarm for log "0" signal at terminal strip XM, terminal 213 (when the air flow monitoring sensor responds or the sensor cable is interrupted).

#### **W05 Motor temperature, binary**

##### **Mode of operation**

For parameter P145 = 1xxx:

Alarm for log "0" signal at terminal strip XM, terminal 214 (when the thermo switch for motor temperature monitoring has responded or when the sensor cable is interrupted).

#### **W06 Motor temperature, analog**

##### **Mode of operation**

For parameter P146 = 1 or 2:

Alarm when the motor temperature reaches or exceeds the value set at parameter P147.

For parameter P146 = 3, 5, 7 or 9:

Alarm when the motor temperature reaches or exceeds the response value of the selected PTC.

**W07 Short-circuit at the binary outputs****Mode of operation**

Hardware monitoring as to whether one of the binary select outputs is short-circuited (also refer to F028, Section 8.2.2.2).

**W08 Drive stalled****Mode of operation**

The monitoring responds, if the following conditions are fulfilled for a time longer than that set at parameter P355:

- Positive or negative torque or armature current limit reached
- The armature current is greater than 1% of the rated converter armature DC current
- The speed actual value is < 0.4% of the maximum speed

**W09 No armature current can flow****Mode of operation**

The monitoring function responds, when the armature firing angle is at the rectifier stability limit for more than 500 ms, and the armature current is < 1% of the rated converter armature DC current.

**W10 I<sup>2</sup>t value of the power section too large****Mode of operation**

The alarm is initiated, if the permissible I<sup>2</sup>t value is reached for the particular power section. Simultaneously, the current limit is limited to P077 \* 100% of the rated converter DC current. This limit is only cancelled again, if the setpoint falls below 100% of the rated converter DC current. Also refer to fault F039 and parameter P075.

**W12 Automatic field current reduction, if EMF in operation is too high**

**from SW2.00**

**Mode of operation**

The alarm is only active for parameter P082 = 1x and is initiated, if the following is valid for the firing angle  $\alpha$  (armature) before limiting (K101):

- $\alpha > (\alpha_W \text{ ((inverter stability limit acc. to P151) - 5 degrees, or for low (discontinuous) current})$
- $\alpha > (165 \text{ degrees} - 5 \text{ degrees})$

The field is simultaneously reduced with W12. The field is reduced by controlling the armature firing angle to  $(\alpha_W \text{ (or 165 degrees) - 5 degrees})$  using a P controller, whose output is reduced to the EMF controller setpoint. Thus, "field current setpoint input via internal EMF control" should be parameterized (P082 = x1x).

If a torque direction change is demanded, both torque directions are inhibited, until the calculated firing angle (K101) is < 165 degrees, for the armature current demanded for the new torque direction, i.e. until the field, and thus the EMF, have been appropriately reduced.

Also refer to parameter P082, Section 9.2.

**W16 Analog input main setpoint (terminals 4 and 5) faulted from SW2.00**

**Mode of operation**

The alarm is initiated, if P703 = 1x (4 to 20 mA input), and if an input current less than 3 mA flows (also refer to F046)

**W17 Analog select input 1 (terminal 6 and 7) faulted from SW2.00**

**Mode of operation**

The alarm is initiated, if P713 = 1x (4 to 20 mA input), and if an input current less than 3 mA flows (also refer to F047)

**W21 Alarm signal at binary select input 1**  
(when using the binary input function, BEF54)

**W22 Alarm signal at binary select input 2**  
(when using the binary input function, BEF54)

**W23 Alarm signal at binary select input 3**  
(when using the binary input function, BEF54)

**W24 Alarm signal at binary select input 4**  
(when using the binary input function, BEF54)

**W25 Alarm signal at binary select input 5**  
(when using the binary input function, BEF54)

**W26 Alarm signal at binary select input 6**  
(when using the binary input function, BEF54)

**W28 Connection between the basic converter and supplementary board faulty from SW1.10**

**Mode of operation**

The alarm is present, if process data transfer between basic converter and supplementary board is faulted (also refer to P911, P926, P929)

**W29 Alarm on the technology board from SW1.10**

**W30 Alarm on the interface board from SW1.10**

## 9. Parameter list

The parameter list covers all of the basic converter parameters.

Additional parameters, which are required in conjunction with option boards, are documented in the associated Instruction Manuals.

### 9.1 Parameter overview

Parameters, which can be reached by setting parameter P052

| P052 = 1                  | P052 = 2 | P052 = 3 | Function   |
|---------------------------|----------|----------|--|
| <b>Display parameters</b> |          |          |  |
| P000                      | P000     | P000     | Operating status displays                                  |
| P001                      | P001     | P001     | Display, terminals 4 and 5 (main setpoint)                 |
| P002                      | P002     | P002     | Display, terminals XT.101 to XT.104 (main actual value)    |
| P003                      | P003     | P003     | Display, terminals 6 and 7 (select input analog 1)         |
|                           | P004     | P004     | Display, terminal 8 (select input analog 2)                |
|                           | P005     | P005     | Display, terminal 10 (select input analog 3)               |
| P006                      | P006     | P006     | Display, terminal 14 (analog select output 1)              |
|                           | P007     | P007     | Display, terminal 16 (analog select output 2)              |
|                           | P008     | P008     | Display, terminal 18 (analog select output 3)              |
|                           | P009     | P009     | Display, terminal 20 (analog select output 4)              |
| P010.ii                   | P010.ii  | P010.ii  | Status of the binary inputs (terminals and control words)  |
| P011.ii                   | P011.ii  | P011.ii  | Status of the binary outputs (terminals and status words)  |
|                           | P012     | P012     | Display of the temperature measured at terminals 22 and 23 |
|                           | P013     | P013     | Motor temperature display (for "motor interface" option)   |
|                           | P014     | P014     | Brush length display (for "motor interface" option)        |
| P015                      | P015     | P015     | Supply voltage display (armature)                          |
| P016                      | P016     | P016     | Supply voltage display (field)                             |
| P017                      | P017     | P017     | Supply frequency display                                   |
|                           | P018     | P018     | Firing angle display (armature)                            |
| P019                      | P019     | P019     | Armature current actual value display                      |
| P020                      | P020     | P020     | Armature current setpoint display                          |
|                           | P021     | P021     | Display of the torque setpoint after torque limiting       |
|                           | P022     | P022     | Display of the torque setpoint before torque limiting      |
| P023                      | P023     | P023     | Speed controller, setpoint-actual value difference display |
| P024                      | P024     | P024     | Display of the speed actual value from the pulse encoder   |
| P025                      | P025     | P025     | Display of the speed controller actual value               |
| P026                      | P026     | P026     | Display of the speed controller setpoint                   |
| P027                      | P027     | P027     | Display of the ramp-function generator output              |

| P052 = 1  | P052 = 2 | P052 = 3 | Function   |
|---|----------|----------|--|
|   | P028     | P028     | Display of the ramp-function generator input after limiting              |
|   | P029     | P029     | Display of the ramp-function generator input before limiting             |
|   | P030     | P030     | Display of the technology controller output from SW1.10                  |
|   | P032     | P032     | Display of the technology controller actual value from SW1.10            |
|   | P033     | P033     | Display of the technology controller setpoint from SW1.10                |
|   | P034     | P034     | Firing angle display (field)   |
| P035  | P035     | P035     | Display of the field current actual value                                |
| P036  | P036     | P036     | Display of the field current setpoint                                    |
|   | P037     | P037     | Display of the EMF actual value  |
| P038  | P038     | P038     | Display of the armature voltage actual value                             |
|   | P039     | P039     | Display of the EMF setpoint  |
| P040  | P040     | P040     | Display of the limits  |
|   |          | P041     | Display of the connector selected at parameter P861.01                   |
|   |          | P042     | Display of the connector selected at parameter P861.02                   |
|   |          | P043     | Select display parameter 1   |
|   |          | P044     | Selecting the display value for the select display parameter 1 (P043)    |
|   |          | P045     | Select display parameter 2   |
|   |          | P046     | Selecting the display value for the select display parameter 2 (P045)    |
| P047.ii   | P047.ii  | P047.ii  | Fault diagnostic memory display  |
| P048  | P048     | P048     | Operating hours display  |
| P049  | P049     | P049     | Display of alarms W00 to W14   |
| P050  | P050     | P050     | Display of alarms W16 to W30   |
| <b>Access authorizations and parameter output</b> |          |          |  |
| P051  | P051     | P051     | Key parameter  |
| P052  | P052     | P052     | Select the parameter to be displayed                                     |
| P053  | P053     | P053     | Control word for the permanent memory                                    |
| P054  | P054     | P054     | Select the parameter set to be displayed                                 |
| P055  | P055     | P055     | Copy parameters from SW2.00  |
| P056  | P056     | P056     | Displaying the activated parameter set from SW2.00                       |
| <b>Definition of the SIMOREG converter</b>        |          |          |  |
| P060  | P060     | P060     | Software release   |
| P064  | P064     | P064     | Converter operator control panel: Operating display, 1st line            |
| P065  | P065     | P065     | Converter operator control panel: Operating display, 2nd line            |
| P066  | P066     | P066     | Selecting the fct. of the I key at the conv. op. ctrl. panel from SW2.00 |
| P067  | P067     | P067     | Selecting the fct. of the O key at the conv. op. ctrl. panel from SW2.00 |

| P052 = 1                                       | P052 = 2 | P052 = 3 | Function  |             |
|--|----------|----------|---|-------------|
| <b>Definition of the SIMOREG power section</b> |          |          |   |             |
| P070   | P070     | P070     | Gating board type (A1601, A1603, A1608)                               |             |
| P071   | P071     | P071     | Rated supply voltage of the armature power section feeder             |             |
| P072   | P072     | P072     | Rated converter DC current (armature)                                 |             |
| P073   | P073     | P073     | Rated converter DC current (field)                                    |             |
| P074   | P074     | P074     | Control word for the power section                                    |             |
| P075   | P075     | P075     | Control word for the I <sup>2</sup> t monitoring of the power section |             |
| P076   | P076     | P076     | Select EU/US power section  |             |
| P077   | P077     | P077     | Total thermal reduction factor  | from SW2.00 |
| P078   | P078     | P078     | Rated field supply voltage  | from SW2.00 |
| <b>Converter control settings</b>              |          |          |   |             |
|  | P080     | P080     | Control word for the brake control                                    | from SW2.00 |
| P082   | P082     | P082     | Field mode  |             |
| P083   | P083     | P083     | Selecting the speed actual value                                      |             |
| P084   | P084     | P084     | Select cl.-loop speed / current contr. and closed-loop torque contr.  |             |
|  |          | P085     | Delay time after withdrawing the inching command                      |             |
|  | P086     | P086     | Voltage failure time for automatic restart                            |             |
|  | P087     | P087     | Brake release time  |             |
|  | P088     | P088     | Brake closing time  |             |
|  |          | P089     | Wait for voltage at the power section (max. time)                     |             |
|  |          | P090     | Supply voltage stabilizing time                                       |             |
|  | P091     | P091     | Setpoint threshold  | from SW2.00 |
|  |          | P092     | Delay time for field decay at field reversal                          | from SW2.00 |
|  | P093     | P093     | Line contactor close delay  | from SW2.00 |
|  | P094     | P094     | Off delay for auxiliaries   | from SW2.00 |
| <b>Adjustable fixed setpoints</b>              |          |          |   |             |
|  | P096     | P096     | Fixed setpoint 1  | from SW2.00 |
|  | P097     | P097     | Fixed setpoint 2  | from SW2.00 |
|  | P098     | P098     | Fixed setpoint 3  | from SW2.00 |
|  | P099     | P099     | Digital fixed value   |             |

| P052 = 1                        | P052 = 2 | P052 = 3 | Function   |
|---------------------------------|----------|----------|--|
| <b>Definition of the motor</b>  |          |          |  |
| P100                            | P100     | P100     | Rated motor armature current (acc. to the motor rating plate)                |
| P101                            | P101     | P101     | Rated motor armature voltage (acc. to the motor rating plate)                |
| P102                            | P102     | P102     | Rated motor field current (according to the motor rating plate)              |
| P103                            | P103     | P103     | Minimum motor field current  |
| P104                            | P104     | P104     | Speed $n_1$ from SW2.00  |
| P105                            | P105     | P105     | Armature current $I_1$ from SW2.00   |
| P106                            | P106     | P106     | Speed $n_2$ from SW2.00  |
| P107                            | P107     | P107     | Armature current $I_2$ from SW2.00   |
| P108                            | P108     | P108     | Max. operating speed ( $n_3$ ) from SW2.00                                   |
| P109                            | P109     | P109     | Control word for the speed-dependent curr. limiting from SW2.00              |
|                                 | P110     | P110     | Armature circuit resistance  |
|                                 | P111     | P111     | Armature circuit inductance  |
|                                 | P112     | P112     | Field circuit resistance   |
| P114                            | P114     | P114     | Thermal time constant (motor)  |
| P115                            | P115     | P115     | Maximum speed for operation without tachometer<br>(EMF = speed actual value) |
|                                 |          | P117     | Control word for the field characteristic                                    |
|                                 |          | P118     | Rated EMF  |
|                                 |          | P119     | Rated speed (% of the maximum speed)   |
|                                 |          | P120     | Field current at 0% motor flux (field characteristic, point No. 0)           |
|                                 |          | P121     | Field current at 5% motor flux (field characteristic, point No. 1)           |
|                                 |          | to       |  |
|                                 |          | P139     | Field current at 95% motor flux (field characteristic, point No. 19)         |
| <b>Pulse encoder definition</b> |          |          |  |
| P140                            | P140     | P140     | Pulse encoder type   |
| P141                            | P141     | P141     | Pulse encoder, pulse number  |
| P142                            | P142     | P142     | Control word for the pulse encoder   |
| P143                            | P143     | P143     | Maximum speed for pulse encoder operation (rough)                            |
| P144                            | P144     | P144     | Control word for position sensing from SW1.10                                |



| P052 = 1  | P052 = 2 | P052 = 3 | Function   |
|---|----------|----------|--|
| <b>Definition of the "motor interface" option</b>   |          |          |  |
|   | P145     | P145     | Control parameter for the "motor interface" option   |
|   | P146     | P146     | Selecting the temperature sensor for the "motor interface" option (connected to terminals XM-204 and XM-205) |
|   | P147     | P147     | Alarm temperature  |
|   | P148     | P148     | Shutdown temperature   |
| <b>Closed-loop control optimization</b>             |          |          |  |
| <b>Settings for the armature current control</b>    |          |          |  |
|   |          | P150     | Alpha <sub>G</sub> limit (armature)  |
|   |          | P151     | Alpha <sub>w</sub> limit (armature)  |
|   |          | P152     | Filtering of the supply frequency tracking (armature)  |
|   |          | P153     | Control word, armature pre-control   |
|   |          | P154     | Control word, armature current controller  |
| P155  | P155     | P155     | Armature current controller, P gain  |
| P156  | P156     | P156     | Armature current controller, integral-action time  |
|   |          | P157     | Control word, current setpoint integrator <span style="float: right;">from SW2.00</span>                     |
|   |          | P158     | Ramp-up time for the curr. setp. integr. (reduced gearbox stressing)   |
|   |          | P159     | Changeover threshold for the auto-reversing stage (armature)   |
|   |          | P160     | Additional torque-free interval <span style="float: right;">from SW2.00</span>                               |
| <b>Settings for the current and torque limiting</b> |          |          |  |
|   | P170     | P170     | Torque control/current control selection   |
| P171  | P171     | P171     | System current limit in torque direction I   |
| P172  | P172     | P172     | System current limit in torque direction II  |
| P180  | P180     | P180     | Positive torque limit 1  |
| P181  | P181     | P181     | Negative torque limit 1  |
|   | P182     | P182     | Positive torque limit 2  |
|   | P183     | P183     | Negative torque limit 2  |
|   | P184     | P184     | Changeover speed for the torque limits   |

| P052 = 1   | P052 = 2 | P052 = 3 | Function  |
|--|----------|----------|---|
| <b>Settings for the speed controller actual value conditioning</b> |          |          |   |
| P200   | P200     | P200     | Filter time for the speed controller actual value   |
|  | P201     | P201     | Resonant frequency of the first band-stop filter from SW1.10  |
|  | P202     | P202     | Quality of the first band-stop filter from SW1.10   |
|  | P203     | P203     | Resonant frequency of the second band-stop filter from SW1.10   |
|  | P204     | P204     | Quality of the second band-stop filter from SW1.10  |
|  | P205     | P205     | Derivative action time for the D component in the speed controller - actual value channel from SW1.10 |
| <b>Settings for the speed controller</b>                           |          |          |   |
|  |          | P220     | Speed controller, integrator setting value 1  |
|  |          | P222     | Changeover threshold, PI / P controller   |
|  | P223     | P223     | Control word, speed controller pre-control from SW1.10  |
|  | P224     | P224     | Control word, speed controller  |
| P225   | P225     | P225     | Speed controller, P gain  |
| P226   | P226     | P226     | Speed controller, integral-action time  |
| P227   | P227     | P227     | Speed controller, droop   |
| P228   | P228     | P228     | Filter time for the speed controller setpoint   |
| P229   | P229     | P229     | Speed controller mode for slave operation from SW2.00   |
| <b>Settings for the field current controller</b>                   |          |          |   |
|  |          | P250     | Alpha <sub>G</sub> limit (field)  |
|  |          | P251     | Alpha <sub>w</sub> limit (field)  |
|  |          | P252     | Filter of the supply frequency tracking (field)   |
|  |          | P253     | Control word, field pre-control   |
|  |          | P254     | Control word, field current controller  |
| P255   | P255     | P255     | Field current controller, P gain  |
| P256   | P256     | P256     | Field current controller, integral-action time  |
| P257   | P257     | P257     | Standstill field  |
|  | P258     | P258     | Delay time for automatic field current reduction  |

| P052 = 1  | P052 = 2  | P052 = 3                     | Function   |                  |
|---|---|------------------------------|--|------------------|
| <b>Settings for the EMF control</b>             |   |                              |  |                  |
| P275<br>P276                                    | P275<br>P276                                    | P273                         | Control word, EMF controller pre-control   |                  |
|   |   | P274                         | Control word, EMF controller   |                  |
|   |   | P275                         | EMF controller, P gain   |                  |
|   |   | P276                         | EMF controller, integral-action time   |                  |
|   |   | P277                         | EMF controller, droop  |                  |
| <b>Ramp-function generator settings</b>         |   |                              |  |                  |
|   | P302  | P300                         | Positive limit for the ramp-function generator output                                |                  |
|   |   | P301                         | Negative limit for the ramp-function generator output                                |                  |
|   |   | P302                         | Control word, ramp-function generator  |                  |
| <b>Ramp-function generator, parameter set 1</b> |   |                              |  |                  |
| P303<br>P304<br>P305<br>P306                    | P303<br>P304<br>P305<br>P306                    | P303<br>P304<br>P305<br>P306 | Ramp-up time 1<br>Ramp-down time 1<br>Initial rounding-off 1<br>Final rounding-off 1 |                  |
| <b>Ramp-function generator, parameter set 2</b> |   |                              |  |                  |
|   | P307<br>P308<br>P309<br>P310                    | P307<br>P308<br>P309<br>P310 | Ramp-up time 2<br>Ramp-down time 2<br>Initial rounding-off 2<br>Final rounding-off 2 |                  |
|   | <b>Ramp-function generator, parameter set 3</b> |                              |  |                  |
|   |   |                              | P311   | Ramp-up time 3   |
|   |   |                              | P312   | Ramp-down time 3 |
| P313  |   |                              | Initial rounding-off 3   |                  |
| P314  |   |                              | Final rounding-off 3   |                  |

| P052 = 1  | P052 = 2 | P052 = 3 | Function   |
|---|----------|----------|--|
| <b>Speed limiting</b>                           |          |          |  |
|   |          | P315     | Positive limit for the ramp-function generator input               |
|   |          | P316     | Negative limit for the ramp-function generator input               |
| P317  | P317     | P317     | Speed limit, "maximum speed" (setpoint branching)                  |
| P318  | P318     | P318     | Speed limit, "minimum speed" (setpoint branching)                  |
|   | P319     | P319     | Speed setpoint reduction, positive direction                       |
|   | P320     | P320     | Speed setpoint reduction, negative direction                       |
| <b>Settings for monitoring and limit values</b> |          |          |  |
| <b>Monitoring settings</b>                      |          |          |  |
|   | P351     | P351     | Threshold for the undervoltage trip                                |
|   | P352     | P352     | Threshold for the overvoltage trip                                 |
|   |          | P353     | Response threshold for phase failure monitoring                    |
| P354  | P354     | P354     | Threshold for overspeed protection                                 |
| P355  | P355     | P355     | Stall protection time  |
|   | P357     | P357     | Threshold for the tachometer interruption monitoring               |
|   | P362     | P362     | Threshold for the speed controller monitoring                      |
|   | P363     | P363     | Time for the dynamic control deviation of the speed controller     |
|   |          | P364     | Threshold for the armature current controller monitoring           |
|   |          | P365     | Time for dynamic control deviation of armature current controller  |
|   |          | P366     | Threshold for the EMF controller monitoring                        |
|   |          | P367     | Time for the dynamic control deviation of the EMF controller       |
|   |          | P368     | Threshold for the field current controller monitoring              |
|   |          | P369     | Time for dynamic control deviation of the field current controller |
| <b>Settings for the limit value monitor</b>     |          |          |  |
| P370  | P370     | P370     | Speed threshold $n_{min}$  |
| P371  | P371     | P371     | Hysteresis for the $n < n_{min}$ signal                            |
| P373  | P373     | P373     | Speed threshold $n_{x1}$ ( $n_{base}$ )                            |
| P374  | P374     | P374     | Hysteresis for the $n < n_{x1}$ signal ( $n < n_{base}$ signal)    |
|   | P376     | P376     | Speed threshold $n_{x2}$   |
|   | P377     | P377     | Hysteresis for the $n < n_{x2}$ signal                             |
|   | P379     | P379     | Speed threshold $n_{x3}$   |
|   | P380     | P380     | Hysteresis for the $n < n_{x3}$ signal                             |
|   |          | P382     | Speed threshold $n_{x4}$   |
|   |          | P383     | Hysteresis for the $n < n_{x4}$ signal                             |

| P052 = 1 | P052 = 2 | P052 = 3 | Function  |
|----------|----------|----------|---|
|          |          | P385     | Speed threshold $n_{x5}$  |
|          |          | P386     | Hysteresis for the $n < n_{x5}$ signal                            |
| P391     | P391     | P391     | Armature current threshold $I_x$                                  |
| P392     | P392     | P392     | Hysteresis for the $I_A > I_x$ signal                             |
|          |          | P394     | Field current threshold $I_{f_{min}}$                             |
|          |          | P395     | Hysteresis for the $I_f < I_{f_{min}}$ signal                     |
|          |          | P396     | Hysteresis for the direction of rotation signal (ccw) from SW2.00 |

### Settings for the basic converter technology functions

#### Settings for the "digital setpoint (e.g. inching)" function

|      |      |      |  |
|------|------|------|--|
| P401 | P401 | P401 | Digital setpoint 1   |
| P402 | P402 | P402 | Digital setpoint 2   |
|      | P403 | P403 | Digital setpoint 3   |
|      | P404 | P404 | Digital setpoint 4   |
|      | P405 | P405 | Digital setpoint 5   |
|      | P406 | P406 | Digital setpoint 6   |
|      | P409 | P409 | Setpoint for "inching" from the control word from SW1.10   |
|      | P410 | P410 | Setpoint for "inching and bypass ramp-function generator" from the control word from SW1.10                |
|      | P411 | P411 | Setpoint for "crawl" from the control word from SW1.10   |
|      | P412 | P412 | Setpoint for "crawl and bypass ramp-function generator" from the control word from SW1.10                  |
|      | P413 | P413 | Setpoint for "fixed setpoint" from the control word from SW1.10  |
|      | P414 | P414 | Setpoint for "fixed setpoint and bypass ramp-function generator" from the control word from SW1.10         |
|      | P415 | P415 | Setpoint for "supplementary setpoint before the technology controller" from the control word from SW1.10   |
|      | P416 | P416 | Setpoint for "supplementary setpoint before the ramp-function generator" from the control word from SW1.10 |
|      | P417 | P417 | Setpoint for "supplementary setpoint before the speed controller" from the control word from SW1.10        |
|      | P418 | P418 | Setpoint for "supplementary setpoint before torque limiting" from the control word from SW1.10             |
|      | P419 | P419 | Setpoint for "supplementary setpoint before the current controller" from the control word from SW1.10      |

| P052 = 1   | P052 = 2 | P052 = 3 | Function   |             |
|--|----------|----------|--|-------------|
| <b>Settings for the "technology controller" function</b>     |          |          |  |             |
|  | P420     | P420     | Filter time, technology controller actual value      | from SW1.10 |
|  | P421     | P421     | Derivative action time, technology contr. act. value | from SW1.10 |
|  | P422     | P422     | Filter time for the technology controller setpoint   | from SW2.00 |
|  | P424     | P424     | Control word, technology controller                  | from SW1.10 |
|  | P425     | P425     | Technology controller, P gain                        | from SW1.10 |
|  | P426     | P426     | Technology controller, integral action time          | from SW1.10 |
|  | P427     | P427     | Technology controller, droop                         | from SW1.10 |
|  | P428     | P428     | Evaluation factor for the technology contr. output   | from SW1.10 |
|  | P430     | P430     | Pos. limit for the technology controller output      | from SW2.00 |
|  | P431     | P431     | Neg. limit for the technology controller output      | from SW2.00 |
|  | P432     | P432     | Pos. limit for the technology controller droop       | from SW2.00 |
|  | P433     | P433     | Neg. limit for the technology controller droop       | from SW2.00 |
|  |          | P450     | Max. speed at the gearbox outdrive (rough)           | from SW2.00 |
|  |          | P451     | Max. speed at the gearbox outdrive (fine)            | from SW2.00 |
| P452   | P452     | P452     | Max. speed for pulse encoder operation (fine)        | from SW2.00 |
| <b>Settings for the "motorized potentiometer" function</b>   |          |          |  |             |
|  | P460     | P460     | Selecting the motorized pot.operating mode           | from SW1.10 |
|  | P461     | P461     | Selecting the motorized potentiometer setpoint       | from SW1.10 |
|  | P462     | P462     | Motorized potentiometer ramp-up time                 | from SW1.10 |
|  | P463     | P463     | Motorized potentiometer ramp-down time               | from SW1.10 |
|  | P464     | P464     | Motorized potentiometer evaluation factor            | from SW1.10 |
|  | P465     | P465     | Zoom factor for the motorized potentiometer          | from SW2.00 |
|  | P466     | P466     | Selecting the motorized potentiometer setting value  | from SW2.00 |
| <b>Settings for the "tension and ratio control" function</b> |          |          |  |             |
|  | P470     | P470     | Selecting the mode for the tension/ratio control     | from SW1.10 |
|  | P471     | P471     | Selecting the tension/ratio factor                   | from SW1.10 |

| P052 = 1  | P052 = 2 | P052 = 3 | Function  |             |
|---|----------|----------|---|-------------|
| <b>Settings for the "oscillation" and "forcing" functions</b>     |          |          |   |             |
| P480  | P480     | P480     | Oscillation setpoint 1  | from SW2.00 |
| P481  | P481     | P481     | Oscillation time 1  | from SW2.00 |
| P482  | P482     | P482     | Oscillation setpoint 2  | from SW2.00 |
| P483  | P483     | P483     | Oscillation time 2  | from SW2.00 |
| <b>Settings for the "master/slave drive" function</b>             |          |          |   |             |
|   | P500     | P500     | Selecting the setpoint source for the slave drive                           |             |
| <b>Settings for the "friction compensation" function</b>          |          |          |   |             |
|   | P520     | P520     | Friction at 0% speed  | from SW1.10 |
|   | P521     | P521     | Friction at 10% speed   | from SW1.10 |
|   | to       | to       |   |             |
|   | P529     | P529     | Friction at 90% speed   | from SW1.10 |
|   | P530     | P530     | Friction at 100% speed and higher   | from SW1.10 |
| <b>Settings for the "moment of inertia compensation" function</b> |          |          |   |             |
|   | P540     | P540     | Accelerating time   | from SW1.10 |
|   | P541     | P541     | Acceleration P gain   | from SW1.10 |
|   | P543     | P543     | Threshold for accel. dependent on setp.-act. val. diff.                     | from SW1.10 |
|   | P544     | P544     | Selecting the freely-connectable acceleration                               | from SW1.10 |
|   | P545     | P545     | Selecting the acceleration  | from SW1.10 |
|   | P546     | P546     | Filter time for moment of inertia compensation                              | from SW2.00 |
| <b>Settings for the "speed controller adaption" function</b>      |          |          |   |             |
|   | P550     | P550     | Speed controller, P gain (adaption)   |             |
|   | P551     | P551     | Speed controller, integral-action time (adaption)                           |             |
|   | P552     | P552     | Speed controller, droop (adaption)  |             |
|   | P553     | P553     | Influencing quantity for adapting the speed controller P gain               |             |
|   | P554     | P554     | Influencing quantity for adapting the speed controller integral-action time |             |
|   | P555     | P555     | Influencing quantity for adapting the speed controller droop                |             |
|   | P556     | P556     | Threshold 1 for adapting the speed controller P gain                        |             |
|   | P557     | P557     | Threshold 1 for adapting the speed controller integral-action time          |             |
|   | P558     | P558     | Threshold 1 for adapting the speed controller droop                         |             |
|   | P559     | P559     | Threshold 2 for adapting the speed controller P gain                        |             |
|   | P560     | P560     | Threshold 2 for adapting the speed controller integral-action time          |             |
|   | P561     | P561     | Threshold 2 for adapting the speed controller droop                         |             |

| P052 = 1  | P052 = 2 | P052 = 3 | Function   |
|---|----------|----------|--|
| <b>Structuring the control</b>                              |          |          |  |
| <b>Settings for structuring the torque shell</b>            |          |          |  |
|   |          | P600     | Selecting the gating unit input (armature)                                   |
|   |          | P601.ii  | Selecting the arm. curr. contr. setpoint (before curr. lim.)                 |
|   |          | P602     | Selecting the armature current controller actual value                       |
|   |          | P603.ii  | Selecting the variable current limit in torque direction I                   |
|   |          | P604.ii  | Selecting the variable current limit in torque direction II                  |
|   |          | P605.ii  | Selecting the variable positive torque limit                                 |
|   |          | P606.ii  | Selecting the variable negative torque limit                                 |
|   |          | P607.ii  | Selecting the torque setpoint  |
| <b>Settings for structuring the speed controller</b>        |          |          |  |
|   | P608.ii  | P608.ii  | Selecting the speed controller setpoint                                      |
|   |          | P609     | Selecting the speed controller actual value                                  |
| <b>Settings for structuring the field and EMF control</b>   |          |          |  |
|   |          | P610     | Selecting the gating unit input (field)                                      |
|   |          | P611.ii  | Selecting the field current controller - setpoint input                      |
|   |          | P612     | Selecting the field current controller actual value input                    |
|   |          | P613.ii  | Selecting the variable field current setpoint upper limit                    |
|   |          | P614.ii  | Selecting the variable field current setpoint lower limit                    |
|   |          | P615.ii  | Selecting the EMF controller setpoint  |
|   |          | P616     | Selecting the EMF controller actual value                                    |
| <b>Settings for structuring the ramp-function generator</b> |          |          |  |
|   |          | P620.ii  | Selecting the variable positive limit for the ramp-function generator output |
|   |          | P621.ii  | Selecting the variable negative limit for the ramp-function generator output |
|   |          | P622.ii  | Selecting the input of the speed controller setpoint limiting                |
|   |          | P623.ii  | Selecting the ramp-function generator input                                  |
|   |          | P624.ii  | Selecting the reduction signal for the ramp-fct. generator times             |
|   |          | P625.ii  | Selecting the variable positive limit for the ramp-function generator input  |
|   |          | P626.ii  | Selecting the variable negative limit for the ramp-function generator input  |
|   |          | P627.ii  | Selecting the setpoint input after setpoint enable                           |
|   |          | P628.ii  | Selecting the setpoint input before setpoint enable                          |
|   |          | P629     | Selecting the ramp-function generator setting value from SW2.00              |



| P052 = 1  | P052 = 2 | P052 = 3 | Function   |
|---|----------|----------|--|
| <b>Settings for structuring the technology controller</b>       |          |          |  |
|   | P630.ii  | P630.ii  | Selecting the technology controller setpoint from SW1.10                               |
|   | P631.ii  | P631.ii  | Selecting the technology controller actual value from SW1.10                           |
|   | P632     | P632     | Selecting the variable positive limit for the technology controller output from SW2.00 |
|   | P633     | P633     | Selecting the variable eval. factor, tech. contr. output from SW1.10                   |
|   | P634     | P634     | Selecting the variable negative limit for the technology controller output from SW2.00 |
| <b>Settings for structuring the acceleration switch-in</b>      |          |          |  |
|   | P635.ii  | P635.ii  | Selecting the acceleration switch-in suppl. value from SW1.10                          |
| <b>Settings for structuring the converter open-loop control</b> |          |          |  |
|   | P640     | P640     | Select data source for control word selection from SW1.10                              |
|   | P641     | P641     | Sel. data source for freely-connect. contr. word STWF from SW1.10                      |
|   | P642.ii  | P642.ii  | Sel. functions of the bits of the freely-definable control word STWF from SW1.10       |
| <b>Settings for freely-definable function blocks</b>            |          |          |  |
|   |          | P650.ii  | Selecting the input for adder 1 from SW2.00  |
|   |          | P651.ii  | Selecting input A for multiplier / divider 1 from SW2.00                               |
|   |          | P652     | Selecting input B for multiplier / divider 1 from SW2.00                               |
|   |          | P653.ii  | Selecting input A for the divider from SW2.00  |
|   |          | P654     | Selecting input B for the divider from SW2.00  |
|   |          | P655     | Selecting the input for inverter 1 from SW2.00   |
|   |          | P656.ii  | Selecting input A for changeover switch 1 from SW2.00                                  |
|   |          | P657     | Selecting input B for changeover switch 1 from SW2.00                                  |
|   |          | P658     | Selecting the input for absolute value generator 1 from SW2.00                         |
|   |          | P659     | Selecting input A for limit value monitor 1 from SW2.00                                |
|   |          | P660     | Selecting input B for limit value monitor 1 from SW2.00                                |
|   |          | P661.ii  | Selecting the input for adder 2 from SW2.00  |
|   |          | P662.ii  | Selecting input A for multiplier / divider 2 from SW2.00                               |
|   |          | P663     | Selecting input B for multiplier / divider 2 from SW2.00                               |
|   |          | P664     | Selecting the input for the characteristic from SW2.00                                 |
|   |          | P665     | Selecting the input for inverter 2 from SW2.00   |
|   |          | P666.ii  | Selecting input A for changeover switch 2 from SW2.00                                  |

| P052 = 1 | P052 = 2 | P052 = 3 | Function   |             |
|----------|----------|----------|--|-------------|
|          |          | P667     | Selecting input B for changeover switch 2          | from SW2.00 |
|          |          | P668     | Selecting the input for the limiter                | from SW2.00 |
|          |          | P669     | Selecting the input for absolute value generator 2 | from SW2.00 |
|          |          | P670     | Selecting input A for limit value monitor 2        | from SW2.00 |
|          |          | P671     | Selecting input B for limit value monitor 2        | from SW2.00 |
|          |          | P672.ii  | Selecting the input for adder 3                    | from SW2.00 |
|          |          | P673.ii  | Selecting input A for multiplier / divider 3       | from SW2.00 |
|          |          | P674     | Selecting input B for multiplier / divider 3       | from SW2.00 |
|          |          | P675     | Selecting the input for inverter 3                 | from SW2.00 |
|          |          | P676.ii  | Selecting input A for changeover switch 3          | from SW2.00 |
|          |          | P677     | Selecting input B for changeover switch 3          | from SW2.00 |
|          |          | P679     | Threshold for the dead zone                        | from SW2.00 |
|          |          | P680     | Multiplication factor for multiplier / divider 1   | from SW2.00 |
|          |          | P681     | Multiplication factor for multiplier / divider 2   | from SW2.00 |
|          |          | P682     | Multiplication factor for multiplier / divider 3   | from SW2.00 |
|          |          | P683     | Min. diameter                                      | from SW2.00 |
|          |          | P684     | Control word for the divider                       | from SW2.00 |
|          |          | P686     | Upper limit of the limiter                         | from SW2.00 |
|          |          | P687     | Lower limit of the limiter                         | from SW2.00 |
|          |          | P688     | Control word for absolute value generator 1        | from SW2.00 |
|          |          | P689     | Filter time for filter 1                           | from SW2.00 |
|          |          | P690     | Control word for absolute value generator 2        | from SW2.00 |
|          |          | P691     | Filter time for filter 2                           | from SW2.00 |
|          |          | P692     | Control word for limit value monitor 1             | from SW2.00 |
|          |          | P693     | Hysteresis, limit value monitor 1                  | from SW2.00 |
|          |          | P694     | Control word for limit value monitor 2             | from SW2.00 |
|          |          | P695     | Hysteresis, limit value monitor 2                  | from SW2.00 |
|          |          | P696     | Normalization, speed setpoint                      | from SW2.00 |
|          |          | P697     | Normalization, diameter                            | from SW2.00 |
|          |          | P698.ii  | Characteristic points, x values                    | from SW2.00 |
|          |          | P699.ii  | Characteristic points, y values                    | from SW2.00 |

| P052 = 1  | P052 = 2 | P052 = 3 | Function   |
|---|----------|----------|--|
| <b>Definition of the basic converter hardware interface</b> |          |          |  |
| <b>Analog inputs</b>  |          |          |  |
|   |          | P700     | Main setpoint resolution (terminals 4 and 5) from SW2.00             |
| P701  | P701     | P701     | Normalization, main setpoint (terminals 4 and 5)                     |
| P702  | P702     | P702     | Main setpoint offset (terminals 4 and 5)                             |
| P703  | P703     | P703     | Main setpoint control word (terminals 4 and 5)                       |
| P704  | P704     | P704     | Filter time for the main setpoint (terminals 4 and 5)                |
| P706  | P706     | P706     | Normalization for the main actual value (terminals XT-101 to XT-104) |
| P707  | P707     | P707     | Offset for the main actual value (terminals XT-101 to XT-104)        |
| P708  | P708     | P708     | Control word for the main actual value (terminals XT-101 to XT-104)  |
| P709  | P709     | P709     | Filter time for the main actual value (terminals XT-101 to XT-104)   |
|   |          | P710     | Resolution, analog select input 1 (terminals 6 and 7) from SW2.00    |
| P711  | P711     | P711     | Normalization, analog select input 1 (terminals 6 and 7)             |
| P712  | P712     | P712     | Offset for analog select input 1 (terminals 6 and 7)                 |
| P713  | P713     | P713     | Control word for analog select input 1 (terminals 6 and 7)           |
| P714  | P714     | P714     | Filter time for analog select input 1 (terminals 6 and 7)            |
|   | P716     | P716     | Normalization, analog select input 2 (terminal 8)                    |
|   | P717     | P717     | Offset for analog select input 2 (terminal 8)                        |
|   | P718     | P718     | Control word for analog select input 2 (terminal 8)                  |
|   | P719     | P719     | Filter time for analog select input 2 (terminal 8)                   |
|   | P721     | P721     | Normalization, analog select input 3 (terminal 10)                   |
|   | P722     | P722     | Offset for analog select input 3 (terminal 10)                       |
|   | P723     | P723     | Control word for analog select input 3 (terminal 10)                 |
|   | P724     | P724     | Filter time for analog select input 3 (terminal 10)                  |
| <b>Analog outputs</b>                                       |          |          |  |
| P739  | P739     | P739     | Control word for terminal 12 (current actual value display)          |
| P740  | P740     | P740     | Selecting the function of terminal 14 (analog select output 1)       |
| P741  | P741     | P741     | Control word for analog select output 1 (terminal 14)                |
| P742  | P742     | P742     | Filter time for analog select output 1 (terminal 14)                 |
| P743  | P743     | P743     | Offset for analog select output 1 (terminal 14)                      |
| P744  | P744     | P744     | Normalization for analog select output 1 (terminal 14)               |
|   | P745     | P745     | Selecting the function of terminal 16 (analog select output 2)       |
|   | P746     | P746     | Control word for analog select output 2 (terminal 16)                |
|   | P747     | P747     | Filter time for analog select output 2 (terminal 16)                 |

| P052 = 1              | P052 = 2 | P052 = 3 | Function  |
|-----------------------|----------|----------|---|
|                       | P748     | P748     | Offset for analog select output 2 (terminal 16)                 |
|                       | P749     | P749     | Normalization for analog select output 2 (terminal 16)          |
|                       | P750     | P750     | Selecting the function of terminal 18 (analog select output 3)  |
|                       | P751     | P751     | Control word for analog select output 3 (terminal 18)           |
|                       | P752     | P752     | Filter time for analog select output 3 (terminal 18)            |
|                       | P753     | P753     | Offset for analog select output 3 (terminal 18)                 |
|                       | P754     | P754     | Normalization, analog select output 3 (terminal 18)             |
|                       | P755     | P755     | Selecting the function of terminal 20 (analog select output 4)  |
|                       | P756     | P756     | Control word for analog select output 4 (terminal 20)           |
|                       | P757     | P757     | Filter time for analog select output 4 (terminal 20)            |
|                       | P758     | P758     | Offset for analog select output 4 (terminal 20)                 |
|                       | P759     | P759     | Normalization, analog select output 4 (terminal 20)             |
| <b>Binary inputs</b>  |          |          |   |
| P761                  | P761     | P761     | Selecting the function of terminal 39 (select input, binary 1)  |
| P762                  | P762     | P762     | Selecting the function of terminal 40 (select input, binary 2)  |
|                       | P763     | P763     | Selecting the function of terminal 41 (select input, binary 3)  |
|                       | P764.ii  | P764.ii  | Selecting the function of terminal 42 (select input, binary 4)  |
|                       | P765.ii  | P765.ii  | Selecting the function of terminal 43 (select input, binary 5)  |
|                       | P766     | P766     | Selecting the function of terminal 36 (select input, binary 6)  |
|                       | P767     | P767     | Delay of the external fault                                     |
|                       | P769     | P769     | Control word, for switch-on, shutdown and crawl from SW2.00     |
| <b>Binary outputs</b> |          |          |   |
| P771                  | P770     | P770     | Control word for the binary select outputs                      |
|                       | P771     | P771     | Selecting the function of terminal 46 (select output, binary 1) |
|                       | P772     | P772     | Selecting the function of terminal 48 (select output, binary 2) |
|                       | P773     | P773     | Selecting the function of terminal 50 (select output, binary 3) |
|                       | P774     | P774     | Selecting the function of terminal 52 (select output, binary 4) |
|                       | P775     | P775     | Delay of binary select output 1 (terminal 46)                   |
|                       | P776     | P776     | Delay of binary select output 2 (terminal 48)                   |
|                       | P777     | P777     | Delay of binary select output 3 (terminal 50)                   |
|                       | P778     | P778     | Delay of binary select output 4 (terminal 52)                   |

| P052 = 1  | P052 = 2 | P052 = 3                 | Function  |                                |
|---|----------|--------------------------|---|--------------------------------|
| <b>Configuration of the basic converter serial interfaces</b> |          |                          |   |                                |
| P790  | P780     | P780                     | Protocol selection for G-SST0 (RS485) at X500   |                                |
|   | P781     | P781                     | No. of PZD elements for G-SST0 (RS485) at X500  | from SW1.10                    |
|   | P782     | P782                     | No. of PKW elements for G-SST0 (RS485) at X500  | from SW1.10                    |
|   | P783     | P783                     | Baud rate for G-SST0 (RS485) at X500  |                                |
|   | P784.ii  | P784.ii                  | Send PZD assign. for G-SST0 (RS485) at X500   | from SW1.10                    |
|   | P786     | P786                     | Bus address for G-SST0 (RS485) at X500  | from SW1.10                    |
|   | P787     | P787                     | Telegram failure time for G-SST0 (RS485) at X500  | from SW1.10                    |
|   | P788     | P788                     | Telegram failure time for "peer-to-peer" coupling   | from SW2.00                    |
|   | P790     | P790                     | Protocol selection for G-SST1 (RS232) at X501<br>(or RS485 at X502 on A1618 supplementary board)    |                                |
|   | P791     | P791                     | No. of PZD elements for G-SST1 (RS232) at X501<br>(or RS485 at X502 on A1618 supplementary board)   | from SW1.10                    |
| P793  | P792     | P792                     | No. of PKW elements for G-SST1 (RS232) at X501<br>(or RS485 at X502 on A1618 supplementary board)   | from SW1.10                    |
|   | P793     | P793                     | Baud rate for G-SST1 (RS232) at X501<br>(or RS485 at X502 on A1618 supplementary board)             |                                |
|   | P794.ii  | P794.ii                  | PZD-assignment, send for G-SST1 (RS232) at X501<br>(or RS485 at X502 on A1618 supplementary board)  | from SW1.10                    |
|   | P796     | P796                     | Bus address for G-SST1 (RS232) at X501<br>(or RS485 at X502 on A1618 supplementary board)           | from SW1.10                    |
| P798  | P797     | P797                     | Telegram failure time for G-SST1 (RS232) at X501<br>(or RS485 at X502 on A1618 supplementary board) | from SW1.10                    |
|   | P798     | P798                     | Control word for G-SST1 (RS232) at X501<br>(handshake mode)   |                                |
| <b>Reading-out the trace buffer for diagnostics</b>           |          |                          |   |                                |
|   |          | P840                     | Number of lines recorded by the diagnostic monitor  | from SW2.00                    |
|   |          | P841.ii<br>to<br>P848.ii | Contents of the 1st trace buffer<br><br>Contents of the 8th trace buffer                            | from SW2.00<br><br>from SW2.00 |
|   |          | P849                     | Trigger instant   | from SW2.00                    |
| <b>Disabling fault- and parameter change reports</b>          |          |                          |   |                                |
|   | P850.ii  | P850.ii<br>P855          | Disabling monitoring functions<br>Control word for parameter change reports                         | from SW1.10                    |

| P052 = 1   | P052 = 2 | P052 = 3 | Function  |
|--|----------|----------|---|
| <b>Diagnostic aids</b>   |          |          |   |
| <b>Thyristor diagnostics</b>                                     |          |          |   |
|  |          | P860     | Control word for thyristor diagnostics                                      |
| <b>Settings for diagnostic recording</b>                         |          |          |   |
|  |          | P861.ii  | Numbers of the connectors for diagnostic tracing                            |
|  |          | P862     | Connector number in the trigger condition                                   |
|  |          | P863     | Trigger condition for diagnostic tracing                                    |
|  |          | P864     | Percentage value in the trigger condition for diagnostic tracing            |
|  |          | P865     | Sampling interval for diagnostic tracing                                    |
|  |          | P866     | Trigger delay for diagnostic tracing  |
|  |          | P867     | Control bit for diagnostic tracing  |
|  |          | P868     | Output speed for the analog output of the trace buffer contents from SW2.00 |
|  |          | P869     | Output mode for the analog output of the trace buffer contents from SW2.00  |
|  |          | P870     | Trace parameter output mode from SW2.00                                     |
| <b>Number of write accesses to the permanent (EEPROM) memory</b> |          |          |   |
|  |          | P871     | Number of write accesses to the EEPROM                                      |
|  |          | P872     | Number of page-write accesses to the EEPROM                                 |
| <b>Fault memory</b>  |          |          |   |
| P880.ii  | P880.ii  | P880.ii  | Fault memory  |
| <b>Reading-out memory locations</b>                              |          |          |   |
|  |          | P881     | Segment number of the basic address   |
|  |          | P882     | Segment offset of the basic address   |
|  |          | P883.ii  | Contents of the specified address   |
| <b>Settings for internal converter adjustments</b>               |          |          |   |
|  |          | P884     | Offset adjustment for the field current actual value channel                |
|  |          | P885     | Offset adjustment for the main actual value channel (channel 1)             |
|  |          | P886     | Offset adjustment for the main actual value channel (channel 2)             |
|  |          | P887.ii  | Correction of the measured time instants for the supply zero crossovers     |

| P052 = 1                           | P052 = 2 | P052 = 3 | Function                                 |
|------------------------------------|----------|----------|--|
| <b>Global converter parameters</b> |          |          |  |
|                                    |          | P900     | Hardware configuration                   |
|                                    |          | P902     | Protocol selection for SST1              |
|                                    |          | P903     | Useful data quantity for SST1 (in bytes) |
|                                    |          | P904     | Bus address for SST1                     |
|                                    |          | P905     | Baud rate for SST1                       |
|                                    |          | P906     | Protocol selection for SST2              |
|                                    |          | P907     | Useful data quantity for SST2 (in bytes) |
|                                    |          | P908     | Node address for SST2                    |
|                                    |          | P909     | Baud rate for SST2                       |
|                                    |          | P910     | PKW change rights                        |
|                                    |          | P911     | PZD control                              |
|                                    |          | P916.ii  | PZD assignment, ISW channel 1 (SST1)     |
|                                    |          | P924     | PZD quantity for SST1                    |
|                                    |          | P925     | PKW quantity for SST1                    |
|                                    |          | P926     | Telegram failure monitoring for SST1     |
|                                    |          | P927     | PZD quantity for SST2                    |
|                                    |          | P928     | PKW quantity for SST2                    |
|                                    |          | P929     | Telegram failure monitoring for SST2     |
|                                    |          | P930     | Min. response time                       |
|                                    |          | P931     | Slot time                                |
|                                    |          | P932     | Auto-refresh time                        |
|                                    |          | P971.ii  | PZD assignment, ISW channel 2 (SST2)     |





## 9.2 Parameter description

### Display parameters

- P000 Operating status displays** (refer to Section 8.1)
- P001 Display, terminals 4 and 5 (main setpoint)**  
(also refer to Section 10.1, Sheet 2)  
Nominal display range: -100.0 to 100.0% of the nominal input voltage normalized using P701.  
Value range (steps): -200.0 to 199.9% (0.1%)
- P002 Display, terminals XT.101 to XT.104 (main actual value)**  
(also refer to Section 10.1 Sheet 2)  
Nominal display range: -100.0 to 100.0% of the nominal input voltage normalized using P706.  
Value range (steps): -200.0 to 199.9% (0.1%)
- P003 Display, terminals 6 and 7 (select input analog 1)**  
(also refer to Section 10.1 Sheet 2)  
Nominal display range: -100.0 to 100.0% of the nominal input voltage normalized using P711.  
Value range (steps): -200.0 to 199.9% (0.1%)
- P004 Display, terminal 8 (select input analog 2)**  
(also refer to Section 10.1 Sheet 2)  
Nominal display range: -100.0 to 100.0% of the nominal input voltage normalized using P716.  
Value range (steps): -200.0 to 199.9% (0.1%)
- P005 Display, terminal 10 (select input analog 3)**  
(also refer to Section 10.1 Sheet 2)  
Nominal display range: -100.0 to 100.0% of the nominal input voltage normalized using P721.  
Value range (steps): -200.0 to 199.9% (0.1%)

**P006 Display, terminal 14 (analog select output 1)**

(also refer to Section 10.1 Sheet 3)

Nominal display range: -100.0 to 100.0% of the analog value selected using P740. In this case, parameter 741 (with sign, absolute value, inverted) and P742 (filtering) are taken into account.

Value range (steps): -200.0 to 199.9% (0.1%)

**P007 Display, terminal 16 (analog select output 2)**

(also refer to Section 10.1 Sheet 3)

Nominal display range: -100.0 to 100.0% of the analog value selected using P745. In this case, parameter 746 (with sign, absolute value, inverted) and P747 (filtering) are taken into account.

Value range (steps): -200.0 to 199.9% (0.1%)

**P008 Display, terminal 18 (analog select output 3)**

(also refer to Section 10.1 Sheet 3)

Nominal display range: -100.0 to 100.0% of the analog value selected using P750. In this case, parameter 751 (with sign, absolute value, inverted) and P752 (filtering) are taken into account.

Value range (steps): -200.0 to 199.9% (0.1%)

**P009 Display, terminal 20 (analog select output 4)**

(also refer to Section 10.1 Sheet 3)

Nominal display range: -100.0 to 100.0% of the analog value selected using P755. In this case, parameter 756 (with sign, absolute value, inverted) and P757 (filtering) are taken into account.

Value range (steps): -200.0 to 199.9% (0.1%)

**P010.ii Status of the binary inputs (terminals and control words)**

This parameter indicates the status of the binary inputs (also refer to section 10.3).

(Index ii = 01 to 04 only for software release 2.00 and above)

Display on the simple operator control panel

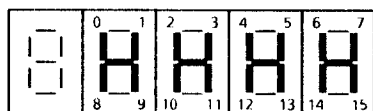

Display on the converter operator control panel

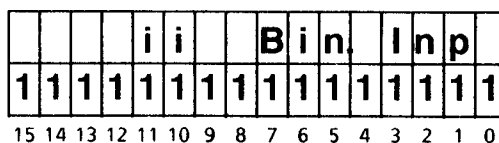

In the OPERATING DISPLAY mode, for the 2-value displays, an "E" is displayed before the bits:



**P010.00** Status of the binary input terminals (= K335)  
(also refer to Section 10.1 Sheet 6, 10.5.1 and 10.5.2)

Segment or bit

|    |      |  |
|----|------|--|
| 0  | .... | Terminal 37 (switch-on)                      |
| 1  | .... | Terminal 38 (operating enable)               |
| 2  | .... | Terminal 39 (select input, binary 1)         |
| 3  | .... | Terminal 40 (select input, binary 2)         |
| 4  | .... | Terminal 41 (select input, binary 3)         |
| 5  | .... | Terminal 42 (select input, binary 4)         |
| 6  | .... | Terminal 43 (select input, binary 5)         |
| 7  | .... | Terminal 36 (select input, binary 6)         |
| 8  | .... | Safety shutdown = Emergency stop present 1)  |
| 9  | .... | Terminal XM-211 (brush length, binary)       |
| 10 | .... | Terminal XM-212 (bearing condition, binary)  |
| 11 | .... | Terminal XM-213 (airflow monitoring, binary) |
| 12 | .... | Terminal XM-214 (thermo switch)              |
| 13 | .... | (not used)                                   |
| 14 | .... | (not used)                                   |
| 15 | .... | (not used)                                   |

Segment lit or "1" ... Appropriate terminal is activated  
(high signal level available)

Segment dark or "0" ... Appropriate terminal is not activated  
(low signal level available)

- 1) Safety shutdown is available (segment dark or "0"), if
- Terminal XS-105 open (switch operation, also refer to Section 10.3.93)
- or
- Terminal XS-107 (stop button) has been briefly opened, and terminal XS-108 (reset button) has still not been activated (pushbutton operation, also refer to Section 10.3.93).

**P010.01** Status of the bits of control word STW (= K315)  
(also refer to Section 10.1, Sheet 6 and Section 10.5.1)

**P010.02** Status of the bits of the freely-definable control word STWF (= K316)  
(also refer to Section 10.1, Sheet 6 and Section 10.5.2)

**P010.03** Status of the bits of control word STW after logical gating with the binary terminal input functions (= K317)  
Also refer to Section 10.1, Sheet 6 and 10.5.1)

**P010.04** Status of the bits of the freely-definable control word STWF, after logical gating with the binary terminal input functions (= K318).  
(also refer to Section 10.1, Sheet 6 and 10.5.2)

**P011.ii Status of the binary outputs (terminals and status words)**

This parameter indicates the status of the binary inputs (also refer to Section 10.4).

(Index ii = 01 to 04 only for software release 2.00 and above)

Display on the simple operator control panel

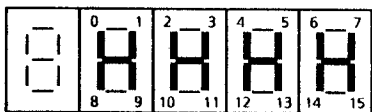

Display on the converter operator control panel

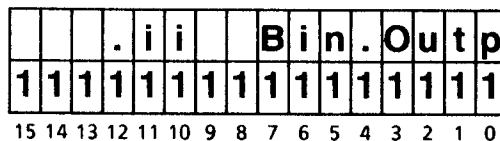

In the OPERATING DISPLAY mode, for the 2-value displays, an "A" is displayed before the bits:



**P011.00** Status of the binary output terminals (= K336)  
(also refer to Section 10.1 Sheet 4)

Segment or bit

- 1 . . . . Terminal 46 (select output, binary 1)
- 2 . . . . Terminal 48 (select output, binary 2)
- 3 . . . . Terminal 50 (select output, binary 3)
- 4 . . . . Terminal 52 (select output, binary 4)
- 7 . . . . Terminal 109 and 110 (relay contact for the line contactor)

Segment lit or "1" . . . . Appropriate terminal is activated  
(high signal level available)

Segment dark or "0" . . . . Appropriate terminal is not activated  
(low signal level available)

**P011.01** Status of the bits of the status word ZSW (= K325)  
(also refer to Section 10.6.1)

**P011.02** Status of the bits of the converter-specific status word ZSW1 (= K326)  
(also refer to Section 10.6.2)

**P011.03** Status of the bits of the converter-specific status word ZSW2 (= K327)  
(also refer to Section 10.6.3)

**P012 Display of the temperature measured at terminals 22 and 23**

(when using temperature sensor, type KTY84)

Nominal display range: 0 to 97°C

Value range (steps): 0 to 250°C (1°C)

**P013 Motor temperature display (for "motor interface" option)**

Nominal display range: 0 to 250°C for P146 = 1 (KTY84)  
13 to 240°C for P146 = 2 (PT100)

Value range (steps): 0 to 250°C (1°C)

**P014 Brush length display (for "motor interface" option)**

(also refer to P145 and Section 6.9)

Nominal display range: 0.0 to 80.0 and 100.0%  
0% corresponds to an approximate 12 mm brush length.  
100.0% is displayed for a brush length > 80.0%

Steps: 0.1%

**P015 Supply voltage display (armature)**

(generated as arithmetic rectified average value, RMS value display is valid for sinusoidal voltages, average value of the 3 phase-to-phase supply voltages)

Nominal display range: 60.0 to 750.0V<sub>RMS</sub>

Value range (steps): 0.0 to 1500.0V (0.1V)

**P016 Supply voltage display (field)**

(generated as arithmetic average rectified value, RMS display is valid for sinusoidal voltage)

Nominal display range: 100.0 to 400.0V<sub>RMS</sub>

Value range (steps): 0.0 to 800.0V (0.1V)

**P017 Supply frequency display**

Nominal display range: 40.00 to 65.00Hz

Value range (steps): 0.00 to 100.00Hz (0.01Hz)

**P018 Firing angle display (armature)**

(also refer to Section 10.1, Sheet 18)

Nominal display range: 0.00 to 180.00 degrees

Value range (steps): 0.00 to 180.00 degrees (0.01degrees)

**P019 Armature current actual value display**

(also refer to Section 10.1, Sheet 18)

The int. armature current actual value is displayed (arithmetic average value between two firing pulses).

Nominal display range: -100.0 to 100.0% of the rated DC motor armature current (P100)

Value range (steps): -400.0 to 400.0% (0.1%)

**P020 Armature current setpoint display**

(also refer to Section 10.1, Sheet 18)

Nominal display range: -100.0 to 100.0% of the rated motor armature current (P100)

Value range (steps): -300.0 to 300.0% (0.1%)

**P021 Display of the torque setpoint after torque limiting**

(also refer to Section 10.1, Sheet 17)

Nominal display range: -100.0 to 100.0% of the rated motor torque  
(= rated motor armature current (P100) \* magnetic flux at the  
rated motor field current (P102))

Value range (steps): -400.0 to 400.0% (0.1%)

**P022 Display of the torque setpoint before torque limiting**

(also refer to Section 10.1, Sheet 17)

Nominal display range: -100.0 to 100.0% of the rated motor torque  
(= rated motor armature current (P100) \* magnetic flux at the  
rated motor field current (P102))

Value range (steps): -400.0 to 400.0% (0.1%)

**P023 Speed controller, setpoint-actual value difference display**

(also refer to Section 10.1, Sheet 15)

Nominal display range: -100.0 to 100.00% of maximum speed

Value range (steps): -200.0 to 199.99% (0.01%)

**P024 Display of the speed actual value from the pulse encoder**

Nominal display range: -100.0 to 100.00% of maximum speed

Value range (steps): -200.0 to 199.99% (0.01%)

**P025 Display of the speed controller actual value**

(also refer to Section 10.1, Sheet 15)

Nominal display range: -100.0 to 100.00% of maximum speed

Value range (steps): -200.0 to 199.99% (0.01%)

**P026 Display of the speed controller setpoint**

(also refer to Section 10.1, Sheet 15)

Nominal display range: -100.0 to 100.00% of maximum speed

Value range (steps): -200.0 to 199.99% (0.01%)

**P027 Display of the ramp-function generator output**

(also refer to Section 10.1, Sheet 14)

Nominal display range: -100.0 to 100.00% of maximum speed

Value range (steps): -200.0 to 199.99% (0.01%)

- P028 Display of the ramp-function generator input after limiting**  
(also refer to Section 10.1, Sheet 14)  
Nominal display range: -100.0 to 100.00% of maximum speed  
Value range (steps): -200.0 to 199.99% (0.01%)
- P029 Display of the ramp-function generator input before limiting**  
(also refer to Section 10.1, Sheet 12)  
Nominal display range: -100.0 to 100.00% of maximum speed  
Value range (steps): -200.0 to 199.99% (0.01%)
- P030 Display of the technology controller output** **from SW1.10**  
(also refer to Section 10.1, Sheet 10)  
Nominal display range: -100.0 to 100.00%  
Value range (steps): -200.0 to 199.99% (0.01%)
- P032 Display of the technology controller actual value** **from SW1.10**  
(also refer to Section 10.1, Sheet 10)  
Nominal display range: -100.0 to 100.00%  
Value range (steps): -200.0 to 199.99% (0.01%)
- P033 Display of the technology controller setpoint** **from SW1.10**  
(also refer to Section 10.1, Sheet 10)  
Nominal display range: -100.0 to 100.00%  
Value range (steps): -200.0 to 199.99% (0.01%)
- P034 Firing angle display (field)**  
(also refer to Section 10.1, Sheet 20)  
Value range (steps): 0.00 to 180.00 degrees (0.01 degrees)
- P035 Display of the field current actual value**  
(also refer to Section 10.1, Sheet 20)  
Nominal display range: 0.0 to 100.0% of the rated motor field current (P102)  
Value range (steps): 0.0 to 199.9% (0.1%)
- P036 Display of the field current setpoint**  
(also refer to Section 10.1, Sheet 20)  
Nominal display range: 0.0 to 100.0% of the rated motor field current (P102)  
Value range (steps): 0.0 to 199.9% (0.1%)

**P037 Display of the EMF actual value**

(also refer to Section 10.1, Sheet 19)

Value range (steps): -1500.0 to 1500.0V (0.1V)

**P038 Display of the armature voltage actual value**

Value range (steps): -1500.0 to 1500.0V (0.1V)

**P039 Display of the EMF setpoint**

(also refer to Section 10.1, Sheet 19)

This parameter indicates the EMF setpoint, which is controlled to in the field weakening range. This value is obtained from:

$$V_{\text{motor}_{\text{rated}}} - I_{\text{motor}_{\text{rated}}} * R_A (= P101 - P100 * P110)$$

Value range (steps): 0.0 to 1500.0V (0.1V)

**P040 Display of the limits**

This parameter displays the status of the limits (= K330).

Display on the simple operator control panel

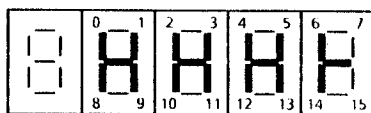

Display on the converter operator control panel

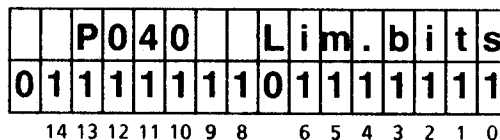

In the OPERATING DISPLAY mode, for 2-value displays, "B" is displayed before the bits:

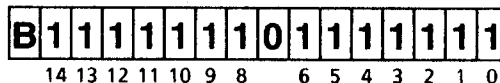

Segment or bit

- 0 ..... Positive ramp-function generator setpoint limit reached
- 1 ..... Positive speed controller setpoint limit reached
- 2 ..... Positive torque limit reached
- 3 ..... Positive current limit (armature) reached
- 4 .....  $\alpha_G$  limit (armature) reached
- 5 ..... Positive current limit (field) reached
- 6 .....  $\alpha_G$  limit (field) reached
- 7 ..... (not used)
- 8 ..... Negative ramp-function generator setpoint limit reached
- 9 ..... Negative speed controller setpoint limit reached
- 10 ..... Negative torque limit reached
- 11 ..... Negative current limit (armature) reached
- 12 .....  $\alpha_w$  limit (armature) reached ( $\alpha_w$  acc. to P151 for cont. current, 165° for discont. current)
- 13 ..... Negative current limit (field) reached
- 14 .....  $\alpha_w$  limit (field) reached

Segment lit or "1" ..... corresponding limit reached

Segment dark or "0" ..... corresponding limit not reached



**P041 Display of the connector selected at parameter P861.01**

Nominal display range: -100.0 to 100.00%

Value range (steps): -200.0 to 199.99% (0.01%)

**P042 Display of the connector selected at parameter P861.02**

Nominal display range: -100.0 to 100.00%

Value range (steps): -200.0 to 199.99% (0.01%)

**P043 Select display parameter 1**

Displays the connector selected at parameter P044.

An internal connector value of  $\pm 16384$  is displayed as  $\pm 100.00\%$ .

Nominal display range: -100.0 to 100.00%

Value range (steps): -200.0 to 199.99% (0.01%)

**P044 Select display value for the select display parameter 1 (P043)**

Connector number, which is to be displayed at parameter P043.

P044 is not stored in the permanent memory, and has the value "0" after the electronics power supply has been switched-on.

Factory setting: 0

Value range: 0 to 399 (connector number)

Access: 10

Change: on-line

**P045 Select display parameter 2**

Displays the connector selected at parameter P046.

An internal connector value of  $\pm 16384$  is displayed as  $\pm 100.00\%$ .

Nominal display range: -100.0 to 100.00%

Value range (steps): -200.0 to 199.99% (0.01%)

**P046 Selecting the display value for the select display parameter 2 (P045)**

Connector number which is to be displayed at parameter P045.

P046 is not stored in the permanent memory, and has the value "0" after the electronics power supply has been switched-on.

Factory setting: 0

Value range: 0 to 399 (connector number)

Access: 10

Change: on-line

**P047.ii Fault diagnostic memory display**

After a fault message provides more information on the fault cause (refer to Sect. 8.2).

Nominal display range: 0000 to FFFF (hexadecimal number)

P047.00 word 0

P047.01 word 1

to

P047.15 word 15 (fault number)

**P048 Operating hours display**

Time, in which the drive was in operating statuses I, II or -- .

All times  $\geq$  approx. 0.1s are taken into account (regarding data storage in the EEPROM, refer to P053).

Factory setting: 0

Value range (steps): 0 to 65535 hours (1 hour)

**P049 Display of alarms W00 to W14**

(refer to Section 8.3.1)

**P050 Display of alarms W16 to W30**

(refer to Section 8.3.1)

**Access authorizations and parameter output****P051 Key parameter**

- 0 No access authorization
- 10 Access authorization to parameter values for operating personnel
- 11 Parameter print-out of changed parameters (refer to Section 10.7.1)
- 12 Complete parameter print-out (refer to Section 10.7.1)
- 13 Fault diagnostic memory print-out after a fault message (refer to Section 10.7.1)
- 14 Trace buffer print-out for diagnostics (refer to Sections 10.7.1 and 10.10)
- 15 Parameter output for parameters changed at the PG or PC (refer to Section 10.7.1)
- 16 Complete parameter output for the PG or PC (refer to Section 10.7.1)
- 17 Fault diagnostic memory output after a fault message on the PG or PC (refer to Section 10.7.1)
- 18 Output of the trace buffer at the PG or PC for diagnostic purposes (refer to Sections 10.7.1 and 10.10)
- 19 Output of the trace buffer at the analog outputs (refer to Section 10.10.3) from SW 2.00
- 20 Access authorization to parameter values for technical personnel
- 21 Reset to default (refer to Section 7.4)
- 22 Carry-out internal offset adjustments (refer to Section 7.4)
- 23 Read-in parameter set from the PG or PC (refer to Section 10.7.2)
- 24 Forcing (refer to Section 10.1, Sheets 12 and 10.12) from SW 2.00
- 25 Optimization run for pre-control and current controller (armature and field) (refer to Section 7.5)
- 26 Optimization run, speed controller (refer to Section 7.5)
- 27 Optimization run, field weakening (refer to Section 7.5)
- 28 Optimization run for friction- and moment of inertia compensation (refer to Section 7.5) from SW1.10
- 30 Access authorization to parameter values for service personnel
- 40 Access authorization to parameter values for authorized service personnel

Factory setting: 0

Value range: 0 to 40

Access: always

Change: on-line

Note: For functions, which are executed via a serial interface (parameter print-out, diagnostics output etc.), the control parameters should be appropriately set for the serial interfaces (P780, P790).

**P052 Select the parameter to be displayed**

- 0 Only parameters, whose values deviate from the factory setting, are displayed  
 Caution:  
 In this mode, longer response times (up to approx 2s) can occur when depressing the RAISE or LOWER key due to the internal search algorithm. For indexed parameters, the index can only be changed in the parameter mode.
- 1 Only parameters for simple applications are displayed  
 2 Additionally, parameters of average complexity  
 3 All parameters which are used are displayed

Factory setting: 3                      Value range: 0 to 3

Access: 10                              Change: on-line

**P053 Control word for the permanent (EEPROM) memory**

Inhibiting or enabling write access to the permanent memory

- x0 Only store parameter P053 in the permanent memory (protection against parameter changes in the permanent memory)  
 Although parameter changes are effective immediately, the changed values are only stored in the RAM and are lost when the electronics power supply is switched-off.
- x1 Save all parameter values in the permanent memory
- 0x Do not store process data which is non-volatile in the permanent memory  
 1x Store all process data which is non-volatile in the permanent memory

If non-volatile process data is not stored (P053 = 0x), the following data is lost when the converter is switched-off:

- a) Last operating status  
 b) Contents of the fault memory (number of the 4 last faults)  
     = P880  
 c) Motor potentiometer setpoint  
 d) Direction of rotation for motorized potentiometer operation  
 e) Operational duration (P048)  
 f) Number of write accesses to the EEPROM (P871, P872)  
 g) EEPROM check sum  
 h) Motor temperature rise  
 i) Thyristor temperature rise

from SW1.10  
 from SW1.10

For active permanent memory inhibit ("software write protection "P053 = x0 or 0x", additionally, a "hardware write protection" can be activated (inhibit write accesses to the permanent memory using plug-in jumper XJ1 on board A1600, refer to Section 6.8.1). In this case, no changes can be stored in the permanent memory.

**CAUTION**

Only a limited number of EEPROM write accesses are guaranteed within its lifetime (10,000).

Thus, frequent parameter value changes via the interfaces (serial basic converter interfaces or cyclic parameter value changes via supplementary board) should, if possible only be realized in the RAM, and not in the EEPROM.

The "change parameter value (and not store in the EEPROM)" task is available for parameter changes via the interface (if the value is only changed in the RAM, the thus changed values are lost when the electronics power supply is switched-off).

The number of write accesses to the EEPROM memory is indicated at parameters P871 and P872.

Factory setting: 11                      Value range: 00 to 11  
Access: 20                                  Change: on-line

### **P054    Select the parameter set to be displayed**

- 1            Standard set 1 is displayed
- 2 to 4      Alternatively, parameter set 2, 3 or 4 is displayed

There are 4 sets of parameters P100 to P599 (for more detailed information, refer to Section 7.3 "Procedure for parameterization"). Parameters of sets 2 to 4 are identified in the display by a P in front of the number (e.g. **3P102** for parameter P102 in the 3rd set). The parameter set, selected with P054, is parameterized.

Note:

Parameter P056 indicates which parameter set is actually being used by the converter (activating set 2, 3 or 4 using binary input functions, refer to Sections 10.3.33, .34, .35)

Factory setting: 1                      Value range: 1 to 4  
Access: 10                                  Change: on-line

### **P055    Copy parameter from SW2.00**

This parameter allows parameter set 1, 2, 3 or 4 to be copied to parameter set 1, 2, 3 or 4, or the contents of parameter set 1, 2, 3 or 4 to be interchanged with parameter set 1, 2, 3 or 4, whereby only parameters which are available 4 times, P100 to P599, are involved (also refer to Section 7.3).

- 0xy    No activity, automatic reset value at the end of copying.
- 1xy    The contents of parameter set x (x = 01, 2, 3 or 4) are copied to parameter set y (y = 1, 2, 3 or 4) (parameter set x remains unchanged, the original contents of parameter set y are overwritten) x and y are the parameter set numbers (1, 2, 3 or 4) from the source- and destination parameter set.
- 2xy    The contents of the parameter set x (x = 1, 2, 3 or 4) are interchanged with those of parameter set y (y = 1, 2, 3 or 4).

Copying is started by changing over P055 in the parameter mode (refer to Section 7.2), if P055 was parameterized for 1xy or 2xy, and the unit is "OFFLINE" (not RUN). P055 is reset to 0xy at the end of copying.

#### **NOTE**

The electronics power supply must remain switched-in for at least 3 minutes after copying has been started, so that the copied parameters can be transferred into the EEPROM (with the EEPROM inhibit not activated, refer to P053).

P055 is not stored in the EEPROM, and has the value "012" after the electronics power supply has been switched-in.

Factory setting: 012                      Value range: 011 to 244  
Access: 20                                  Change: off-line

**P056 Displaying the activated parameter set from SW2.00**

This parameter indicates the number of the presently activated parameter set (1, 2, 3 or 4) (activated via binary input function, refer to Section 10.3.33, .34, .35, operating panel control display, refer to P054).

Value range (steps): 1 to 4 (1) Access: can only be read

**Definition of the SIMOREG converter****P060 Software release**

e.g.: 2.00

Access: can only be read

**P064 Converter operator control panel: Operating display, 1st line**

Parameter number of that parameter, whose value should be displayed in the first line of the display in the "OPERATING DISPLAY" mode (also refer to Section 7.2.2).

For indexed parameters, only the value to index 0 is displayed.

Factory setting: 0 Value range: 0 to 48

Access: 10 Change: on-line

**P065 Converter operator control panel: Operating display, 2nd line**

0 The parameter, selected using P064, is displayed on two lines in the "OPERATING DISPLAY" (also refer to Section 7.2.2).

1 to 48 Parameter number of that parameter whose value should be displayed in the 2nd line of the display in the "OPERATING DISPLAY" mode.

For indexed parameters, only the value to index 0 is displayed.

Factory setting: 0 Value range: 0 to 48

Access: 10 Change: on-line

**P066 Selecting the function of the I key at the op. contr. panel from SW2.00**

0 The I key has no function

1 The I key has the "switch-on" function. Terminal # 37 on the converter is ineffective

2 The I key has the "switch-on" + "operating enable" function. Terminals #37 and #38 on the converter are ineffective.

(also refer to the binary input functions, Sections 10.3.90 and 10.3.91)

Factory setting: 0 Value range: 0 to 2

Access: 20 Change: off-line

**P067 Selecting the function of the O key at the op. contr. panel from SW2.00**

1 The O key has the "shutdown" function.

2 The O key has the "voltage disconnect" function

3 The O key has the "fast stop" function.

(also refer to the binary input functions, Sections 10.3.2, 10.3.3, 10.3.4 and 10.3.90)

Factory setting: 1 Value range: 1 to 3

Access: 20 Change: off-line

## Definition of the SIMOREG power section

### P070 Gating board type (A1601, A1603, A1607)

- 1 Gating board modified for operation with extra-low voltage (85 V)
- 2 Gating board for 400 V DC or 500 V DC converters
- 3 Gating board for 750 V converters

Factory setting: When initializing, a sub-menu appears where this value has to be manually set.

Value range: 1 to 3

Access: 20

Change: off-line

### P071 Rated supply voltage of the armature power section feeder

The rated voltage supplying the armature power section must be set for the supply being actually used. P071 defines the reference level for the undervoltage-, overvoltage- and phase failure monitoring (also refer to P351, P352 and P353).

#### NOTE

The rated converter supply voltage (armature) should be taken from the technical data (Section 3.4). Further, 750 V converters (P070 = 3) can be operated with supply voltages from 400 V to 750 V, 400 V- and 500 V converters (P070 = 2) with input voltages from 85 V to 400 V or 500 V as well as low voltage converters (P070 = 1) with supply voltages from 10 V to 85V. However, the rated DC voltage (armature) specified in the technical data (Section 3.4), can no longer be achieved!

Factory setting: When initializing, a sub-menu appears where this value has to be manually set.

Value range (steps): 10 to 1000V (1V)

Access: 20

Change: off-line

### P072 Rated converter current (armature)

DC output current at power connections 1C1 and 1D1.

The value selected here must correspond to the armature load resistors, which are actually mounted (refer to Section 6.6 "Load resistors").

If SITOR sets are connected in parallel (refer to parameter P074), the sum of the rated DC currents of all power sections, must be set at P072.

Factory setting: When initializing, a sub-menu appears where this value has to be manually set.

Value range (steps): 1.0 to 6553.0A (0.1A)

Access: 20

Change: off-line

**P073 Rated converter current (field)**

DC output current at power terminals 3C and 3D.

The value selected here must correspond to the load resistors for the field, which are actually mounted (refer to Section 6.6 "Load resistors").

Factory setting: When initializing, a sub-menu appears where this value has to be manually set.

Value range (steps): 1.00 to 100.00A (0.01A)

Access: 20 Change: off-line

**P074 Control word for the power section**

xx1 1-quadrant converters

xx2 4-quadrant converters

x0x No parallel-connected SITOR set present

xnx n (1 to 5) parallel-connected SITOR sets available. Thus, it is possible to connect a total of up to 6 power sections in parallel (the same rated DC current). The sum of the rated DC currents of all power sections must be set at P072 (also refer to Section 6.3).

0xx Short pulses (0.89 ms = approx. 16 degrees at 50 Hz) are output at the armature gating unit from SW2.00 (the power section does not have to be re-equipped for operation with long pulses)

1xx Long pulses (pulse duration up to approx. 0.1 ms before the next pulse) is output at the armature gating unit (e.g. required for field supply from the armature terminals). from SW2.00

Caution:

For 30A to 600 A converters, the power section must be re-equipped for operation with long pulses, otherwise the gating board will be damaged!

(Order code: 6RA24xx-xxxxx-Z L03)

Converters with 15 A and  $\geq 640$ A rated DC current are equipped for long pulses without any modifications.

Factory setting: When initializing, a sub-menu appears where this value has to be manually set.

Value range (steps): 001 to 152 (1 hex)

Access: 20 Change: off-line

**P075 Control word for the power section I<sup>2</sup>t monitoring**

This parameter defines the characteristics of the thermal monitoring function (I<sup>2</sup>t monitoring) of the power section (also refer to Section 10.9 "Dynamic overload capability of the power section").

(For US converters, the setting of P075 is of no significance P076 = 2 acts like P075 = x1, P076 = 3 results in limiting to P077 \* 1.8 \* rated converter DC current)

x0 The power section I<sup>2</sup>t monitoring function is disabled.

The armature current is limited to P077 \* rated converter DC current.

- x1 The rated DC current was reduced by increasing the load resistor. The power section I<sup>2</sup>t monitoring is disabled.  
The armature current is limited to  $P077 * 1.5 * \text{rated converter DC current}$  after the rated DC current reduction by increasing the load resistor.

**WARNING**

The thyristors can be thermally overloaded (and possibly destroyed), if P075 = 1 is parameterized, although the rated DC current was not reduced by increasing the load resistor!

- x2 The power section I<sup>2</sup>t monitoring function is active.  
The armature current is limited to  $P077 * 1.5 * \text{rated converter DC current}$ , as long as the calculated equivalent junction temperature rise does not exceed the permissible converter-specific value. Thus, this provides a dynamic overload capability of the power section.
- 02 When the I<sup>2</sup>t monitoring for the power section responds, this results in alarm 10 being issued and the armature current setpoint limit is automatically lowered to  $P077 * \text{rated converter DC current}$  ("interlocking"), until the absolute value of the armature current setpoint falls below the rated converter current before limiting, and the calculated equivalent junction temperature rise falls below the specific converter response threshold. The armature current setpoint limit is then increased again to  $P077 * 1.5 * \text{rated converter DC current}$ , and alarm 10 disappears ("release").
- 12 Fault message F039 is issued and the converter shutdown when the I<sup>2</sup>t monitoring for the power section responds.

Factory setting: 00

Value range (steps): 00 to 12 (1 hex)

Access: 20

Change: on-line

**P076 Select EU/US power section**

- 1 European 6RA24 converters
- 2 Reserved for US converter
- 3 Reserved for US converter

**WARNING**

For European 6RA24 converters, from the type spectrum according to Section 2, P076 must be set 1, as there are different converter functions for settings 2 and 3.

Factory setting: When initializing, a sub-menu appears where this value has to be manually set.

Value range (steps): 1 to 3 (1 hex)

Access: 20

Change: off-line



**P077 Total thermal reduction factor** **from SW2.00**

This reduction factor causes the armature current setpoint limit to be reduced, which is dependent on the setting of P075 (refer to parameter description, P075).

In the following cases, the converter loading capability is reduced:

- Temperature reduction:  
If the ambient temperature is greater than 45°C (for self-ventilated converters), or 35°C (for force-ventilated converters), the converter loading capability is reduced due to the maximum permissible thyristor junction temperature; the percentage reduction is "a", according to the table in Section 3.4, footnote 3.  
This results in the temperature reduction factor  $k_{temp} = (100 - a) / 100$
- Reduction due to installation altitude:  
If the installation altitude lies above 1000 m above sea level, the converter loading capability is reduced due to the lower air density, and the lower cooling effect; the reduction percentage is "b1", according to the table in Section 3.4, footnote 4.  
This results in the installation altitude reduction factor  $k_{altitude} = b1 / 100$
- Reduction when mounting two converters (640A to 1200 A) one above the other:  
When a SIMOREG converter (rated DC current of the armature > 600 A) is connected in parallel with a SITOR set, one above the other, the loading capability of the individual converters is reduced due to the reduced cooling (also refer to Section 6.3).  
This results in a mechanical assembly reduction factor of  $k_{assembly} = 0.85$

P077 should be set as follows:  $P077 = k_{temp} * k_{altitude} * k_{assembly}$

Note:

When reducing the rated converter DC current to 1/3 of the original rated converter value by removing the appropriate parallel load resistors (increasing the resistance), then only parameterization P077 = 1.00 is practical.

Factory setting: 1.00

Value range (steps): 0.50 to 1.00

Access: 20

Change: off-line

**P078 Rated field supply voltage** **from SW2.00**

The rated value of the voltage used for supplying the field must be set. The reference level for the under-, overvoltage and phase failure monitoring of the field supply is specified by P078 (also refer to P351, P352 and P353).

Factory setting: 400V

Value range (steps): 85 to 415V (1V)

Access: 20

Change: off-line

## Converter control settings

### P080 Control word for the brake control

from SW2.00

(also refer to Section 10.4.14)

- 1 The brake is a holding brake  
(When the "operating enable" command is withdrawn, the "disconnect voltage" command entered, or the "emergency stop" command entered, the "close brake" command is only output (binary output function 14), if  $n < n_{\min}$  (P370, P371) is reached.)
- 2 The brake is an operating brake  
(When the "operating enable" command is withdrawn, the "disconnect voltage" or "emergency stop" command is entered, the "close brake" command is immediately output (binary output function 14), i.e., even if the motor is still rotating.)

Factory setting: 1                      Value range: 1 to 2

Access: 20                              Change: off-line

### P082 Field mode

(also refer to Section 10.1, Sheet 19 and 10.3.92)

- xx0 Internal field is not used (e.g. for permanent-magnet motors), and the field firing pulses are inhibited. The motor flux (K290), is not calculated, as in all other cases according to the field characteristic (P120 to P139) as a function of the field current actual value (K265), but is assigned the value for 100% rated flux.
- xx1 The field is switched together with the supply contactor - should be selected, if the supply feed for the field- and armature power section is to be simultaneously switched-in and out (the field firing pulses are switched-in and out together with the line contactor, and the field current decays with the field time constant).
- xx2 The standstill field, set using P257, is automatically switched-in after a time which can be parameterized using P258, after operating status o7 or higher has been reached.
- xx3 Field is permanently switched-in
- x0x No speed- or EMF- dependent field weakening (100% field current setpoint is internally entered).
- x1x Field weakening operation using the internal closed-loop EMF control, so that the motor EMF is held constant at the setpoint  $EMF_{\text{set}} (K289) = P101-P100 * P110$ , in the field weakening range, i.e. at speeds above the motor rated speed (= speed at which field weakening starts) (the field current setpoint is the sum from the EMF controller output and the speed actual value-dependent pre-control component according to the field characteristic).

#### NOTE

For P082 = x1x a valid field characteristic must be available (P117 = 1), otherwise the field weakening optimization run must be executed (P051 = 27).

- 0xx Fault message F043 ("EMF for braking is too high") is active:                      from SW2.00  
If the EMF is too high when a torque direction change is requested (i.e. if the calculated firing angle (K101) is  $> 165^\circ$  for the armature current requested in the new torque direction), both torque directions are inhibited. If the absolute value of the armature current, for the demanded new torque direction is  $> 0.5\%$  of the rated converter DC current (P072), fault message F043 is initiated (also refer to Section 8.2.2).

- 1xx Alarm W12 and automatic field reduction, if the EMF is too high when braking. from SW2.00
- If the EMF is too high during braking (i.e. if the following is valid for the armature firing angle  $\alpha$  before limiting (K101):  $\alpha > (\alpha_w - 5 \text{ degrees})$ ), alarm W12 is issued ( $\alpha_w$  is the inverter stability limit according to P151 or  $165^\circ$  for discontinuous armature current).
- The field is simultaneously reduced with W12. This field reduction is realized by controlling the armature firing angle ( $\alpha_w - 5 \text{ degrees}$ ) using a P controller, whose output reduces the output of the EMF controller setpoint. Thus, the following must be parameterized: "Field weakening operation using the internal EMF control" (P082 = x1x), so that the field reduction can be effective.
- If a torque direction change is requested, both torque directions are inhibited, until the field and thus the EMF have been appropriately reduced (i.e. to the calculated firing angle (K101) is  $< 165^\circ$  for the armature current requested in the new torque direction).

Factory setting: 002                      Value range (steps): 000 to 113 (1 hex)  
 Access: 20                                  Change: off-line

### **P083    Selecting the speed actual value**

(also refer to Section 10.1 Sheet 10)

- 0    Speed actual value is still not selected
- 1    Speed actual value comes from the "main actual value" channel (K004) (terminals XT.101 to XT.104)
- 2    Speed actual value comes from the "speed actual value from the pulse encoder" channel (K012)
- 3    Speed actual value comes from the "EMF actual value" channel (K287), however, is evaluated with P115 (operation without tachometer)
- 4    Speed actual value can be freely-connected (with P609)

Factory setting: 0                          Value range: 0 to 4  
 Access: 20                                  Change: off-line

### **P084    Select closed-loop speed / current control and closed-loop torque control**

(also refer to Section 10.1, Sheet 15)

- 1    Closed-loop speed controlled mode
- 2    Closed-loop current/torque controlled mode (the setpoint issued from the ramp-function generator output is entered as current or torque setpoint, bypassing the speed controller)

Factory setting: 1                          Value range: 1 to 2  
 Access: 20                                  Change: off-line

### **P085    Delay time after withdrawing the inching command**

After an inching command has been withdrawn, the drive remains in operating status o1.3, with inhibited controllers, but with the line contactor energized, for a time which can be selected with this parameter. If an inching command is re-input within this time, the drive goes into the new operating status (o1.2 or lower). However, if the time expires without a new inching command having been entered, the line contactor drops-out, and the drive goes into operating status o7. (also refer to Sections 10.3.13 and 10.3.14).

Factory setting: 10.0s                      Value range (steps): 0.0 to 60.0s (0.1s)  
 Access: 10                                  Change: on-line

**P086 Voltage failure time at automatic restart**

(also refer to Section 8.2.2.1 and 10.13)

If the voltage fails at one of the terminals 1U1, 1V1, 1W1, 3U1, 3W1, 5U1 and 5W1, (F001, F003, F004, F005), or if the voltage is too low (F006 undervoltage) or too high (F007 overvoltage, or its frequency is too low (F008 < 45 Hz) or too high (F009, frequency > 65 Hz), or if the field current actual value is less than 50% of the field current setpoint (F005) for more than 0.5 s, the appropriate fault message is only initiated, if the fault condition does not disappear within the "restart time" selected at this parameter.

The firing pulses and controller are inhibited while the fault conditions lasts. The converter waits in operating status o4 (for armature supply voltage fault) or o5 (for field-supply voltage - or field current fault), or is in 013.

The "automatic restart" function is disabled with the setting 0.0s.

Factory setting: 0.4s                      Value range (steps): 0.0 to 2.0s (0.1s)

Access: 10                                  Change: on-line

**P087 Brake release time**

(also refer to Section 10.4.14)

-10.00 to -0.01 s

from SW2.00

The "open brake" command is delayed by a time set with this parameter, after the firing pulses for the thyristors and the controller have been enabled (i.e. when reaching operating status I, II or --). The motor operates against the closed brake during this time; this is, for example, practical for hanging loads.

0.00 to + 10.00 s

When entering the "switch-on", "inching", "crawl" or "operating enable" commands, a time delay is set with this parameter before the internal controller enable signal becomes effective and in turn the firing pulses, while the drive is in operating status o1.0, in order to allow a holding brake to open.

Factory setting: 0.00s                      Value range (steps): -10.00 to 10.00s (0.01s)

Access: 10                                  Change: on-line

**P088 Brake closing time**

(also refer to Section 10.4.14)

When the "switch-on", "inching" or "crawl" commands are withdrawn when the "switch-on" command is not present, or when the command "fast stop" command is entered, after  $n < n_{min}$  has been reached, up until the internal controller enable is no longer effective, and thus the thyristor firing pulses inhibited, a time delay is inserted, which can be set using this parameter, during which time, the drive still generates a torque (operating status I, II or --), to allow a holding brake to close.

Factory setting: 0.00s                      Value range (steps): 0.00 to 10.00s (0.01s)

Access: 20                                  Change: on-line

**P089 Wait for voltage at the power section**

When entering the "switch-on", "inching" or "crawl" commands with the line contactor open, a delay is inserted in operating statuses o4 and o5 until voltage is present at the power section. If voltage is not identified at the power section within the time set using this parameter, the appropriate fault message is initiated. This parameter specifies the maximum value of the sum of the delay times, in which the drive can stay in operating statuses o4 and o5 (response threshold for monitoring, whether voltage is present at the power section, refer to parameter P353).

Factory setting: 2.0s                      Value range (steps): 0.0 to 60.0s (0.1s)

Access: 20                                      Change: on-line

**P090 Supply voltage stabilizing time**

When entering the "switch-on", "inching" or "crawl" commands, with the line contactor open, and after phase failure has been identified at the armature-or field supply input, with the "automatic restart" function parameterized (P086 > 0), a delay is inserted until voltage is available at the power section, in operating statuses o4 and o5. It is only assumed that the supply voltage is present at the power terminals, if amplitude, frequency and phase symmetry lie within the possible tolerance longer than the time set at this parameter. The parameter is effective for both the armature and field power supply.

Caution:     A lower value must be stored in P090 than in P086 (except, if P086 = 0.0) and in P089!

Factory setting: 0.02s                      Value range (steps): 0.01 to 1.00s (0.01s)

Access: 40                                      Change: on-line

**P091 Setpoint threshold from SW2.00**

It is only possible to switch-on the converter if a setpoint  $|K193| \leq P091$  is present at the ramp-function generator input.

If a higher setpoint is present, the drive waits in status o6 after "switch-on" until the setpoint absolute value  $\leq P091$ .

Factory setting: 199.9%                      Value range (steps): 0.0 to 199.9% (0.1%)

Access: 20                                      Change: on-line

**P092 Delay time for field decay at field reversal from SW2.00**

(also refer to Sections 10.3.57, 10.3.58, 10.4.30, 10.4.31)

This time is used to control a reversing contactor for changing over the field for a 1-quadrant converter with field reversal.

When the field is reversed, after  $I_{\text{field}} < I_{\text{field min}}$  (P394), a delay time, according to P092 must expire, before the actual field contactor is opened.

Factory setting: 3.0 s                      Value range (steps): 0.0 to 3.0s (0.1s)

Access: 20                                      Change: on-line

**P093 Line contactor close delay** **from SW2.00**

(also refer to Section 10.4.7)

The line contactor closes with a delay set here, after the "switch-on auxiliaries" (binary output function BAF7).

Factory setting: 0.0 s

Value range (steps): 0.0 to 120.0s (0.1s)

Access: 20

Change: on-line

**P094 Off delay for auxiliaries** **from SW2.00**

(also refer to Section 10.4.7)

The auxiliaries are shutdown with a delay set here after the line contactor has been opened.

Factory setting: 0.0 s

Value range (steps): 0.0 to 120.0s (0.1s)

Access: 20

Change: on-line

**Adjustable fixed setpoints****P096 Fixed setpoint 1** **from SW2.00**

This digital fixed value can be addressed as connector K096, and is used for adjustment purposes (e.g. for adjusting the end point of analog outputs).

Factory setting: 0.00%

Value range (steps): -200.0 to 199.99% (0.01%)

Access: 20

Change: on-line

**P097 Fixed setpoint 2** **from SW2.00**

This digital fixed value can be addressed as connector K097, and is used for adjustment purposes (e.g. for adjusting the end point of analog outputs).

Factory setting: 0.00%

Value range (steps): -200.0 to 199.99% (0.01%)

Access: 20

Change: on-line

**P098 Fixed setpoint 3** **from SW2.00**

This digital fixed value can be addressed as connector K098, and is used for adjustment purposes (e.g. for adjusting the end point of analog outputs).

Factory setting: 0.00%

Value range (steps): -200.0 to 199.99% (0.01%)

Access: 20

Change: on-line

**P099 Digital fixed value**

This digital fixed value can be addressed as connector K099, and is used for adjustment purposes (e.g. for adjusting the end point of analog outputs).

Factory setting: 0.00%

Value range (steps): -200.0 to 199.99% (0.01%)

Access: 20

Change: on-line

## Definition of the motor

### **P100 Rated motor armature current (acc. to the motor rating plate)**

0.0 Parameter still not set

Factory setting: 0.0A Value range (steps): 0.0 to 6553.0A (0.1A)

Access: 20 Change: off-line

### **P101 Rated motor armature voltage (acc. to the motor rating plate)**

Factory setting:

For European 6RA24 converters (P076 = 1): P101 = 400V

(for US converters (P076 = 2): if P071 = 230V, then P101 = 240V

if P071 = 460V, then P101 = 500V

if P071  $\neq$  230V or  $\neq$  460V, then P101 = 400V)

Value range (steps): 10 to 1000V (1V)

Access: 20 Change: off-line

### **P102 Rated motor field current (acc. to the motor rating plate)**

(also refer to Section 10.1, Sheet 19)

0.0 Parameter still not set

Factory setting: 0.00A Value range (steps): 0.00 to 100.00A (0.01A)

Access: 20 Change: on-line

### **P103 Minimum motor field current**

(also refer to Section 10.1, Sheet 19)

To execute the optimization run for field weakening (P051 = 27), P103 must be parameterized for < 50% of P102.

Factory setting: 0.00A Value range (steps): 0.00 to 100.00A (0.01A)

Access: 20 Change: off-line

### **P104 Speed $n_1$**

**from SW2.00**

(also refer to Section 10.1, Sheet 17 and Section 10.11)

1st point (speed value) of the speed-dependent current limiting.

This parameter, together with P105, P106, P107 and P108 is used to define the current limiting value characteristic as a function of the speed actual value.

Factory setting: 5000 RPM Value range (steps): 1 to 10000 RPM (1 RPM)

Access: 20 Change: off-line

- P105 Armature current  $I_1$**  **from SW2.00**  
 (also refer to Section 10.1, Sheet 17 and Section 10.11)  
 1st point (current value) of the speed-dependent current limiting.  
 This parameter, together with P104, P106, P107 and P108 is used to define the current limiting value characteristic as a function of the speed actual value.  
 Factory setting: 0.1 A                      Value range (steps): 0.1 to 6553.0 A (0.1A)  
 Access: 20                                      Change: off-line
- P106 Speed  $n_2$**  **from SW2.00**  
 (also refer to Section 10.1, Sheet 17 and Section 10.11)  
 2nd point (speed value) of the speed-dependent current limiting.  
 This parameter, together with P104, P105, P107 and P108 is used to define the current limiting value characteristic as a function of the speed actual value.  
 Factory setting: 5000 RPM                      Value range (steps): 1 to 10000 RPM (1 RPM)  
 Access: 20                                      Change: off-line
- P107 Armature current  $I_2$**  **from SW2.00**  
 (also refer to Section 10.1, Sheet 17 and Section 10.11)  
 1st point (current value) of the speed-dependent current limiting.  
 This parameter, together with P104, P105, P106 and P108 is used to define the current limiting value characteristic as a function of the speed actual value.  
 Factory setting: 0.1 A                      Value range (steps): 0.1 to 6553.0 A (0.1A)  
 Access: 20                                      Change: off-line
- P108 Maximum operating speed ( $n_3$ )** **from SW2.00**  
 (also refer to Section 10.1, Sheet 17 and Section 10.11)  
 When using the speed-dependent current limiting, the maximum speed must be set at this parameter, which is defined by selecting the speed actual value source according to P083:  
 for P083 = 1 (analog tachometer):                      Speed, at which a tachovoltage acc. to P706 occurs  
 for P083 = 2 (pulse encoder):                      Same value as the max. speed acc. to P143 (+ P452)  
 for P083 = 3 (operation without tacho):                      Speed, which an EMF acc. to P115 occurs  
 Factory setting: 5000 RPM                      Value range (steps): 1 to 10000 RPM (1 RPM)  
 Access: 20                                      Change: off-line
- P109 Control word for the speed-dependent current limiting** **from SW2.00**  
 (also refer to Section 10.1, Sheet 17 and Section 10.11)  
 0      Speed-dependent current limiting disabled  
 1      Speed-dependent current limiting effective  
 Factory setting: 0                      Value range: 0 to 1  
 Access: 20                                      Change: off-line



**P110 Armature circuit resistance**

(also refer to Section 10.1, Sheets 18 and 19)

The parameter is automatically set during the optimization run for pre-control and current control for armature and field (P051 = 25).

Factory setting: 0.000Ω      Value range (steps): 0.000 to 32.767Ω (0.001Ω)

Access: 30      Change: on-line

**P111 Armature circuit inductance**

(also refer to Section 10.1, Sheet 18)

The parameter is automatically set during the optimization run for pre-control and current controller for armature and field (P051 = 25).

Factory setting: 0.00mH      Value range (steps): 0.00 to 327.67mH (0.01mH)

Access: 30      Change: on-line

**P112 Field resistance**

(also refer to Section 10.1, Sheet 20)

The parameter is automatically set during the optimization run for pre-control and current controller for armature and field (P051 = 25).

Factory setting: 0.0Ω      Value range (steps): 0.0 to 3276.7Ω (0.1Ω)

Access: 30      Change: on-line

**P114 Thermal time constant (motor)**

(refer to Section 10.8)

0.0    I<sup>2</sup>t monitoring disabled

Factory setting: 10.0min      Value range (steps): 0.1 to 80.0min (0.1min)

Access: 20      Change: on-line

**P115 EMF at the maximum speed for operation without tachometer  
(EMF = speed actual value)**

(also refer to Section 10.1, Sheet 15)

The speed is adjusted using this parameter when the internal EMF actual value is used as speed actual value. The parameter specifies, at which EMF as a percentage of P071, the maximum speed should be.

Factory setting: 100.00%      Value range (steps): 1.00 to 140.00% (0.01%) of P071

Access: 20      Change: on-line

**P117 Control word for the field characteristic**

0    A valid field characteristic has still not been recorded

1    Valid field characteristic (P118 to P139 valid)

The parameter is automatically set during the optimization run for the field weakening control (P051 = 27).

Factory setting: 0      Value range: 0 to 1

Access: 40      Change: off-line

**P118 Rated EMF**

(also refer to Section 10.1, Sheet 19)

EMF, which is obtained at full field (corresponding to parameter P102) and a speed according to parameter P119.

The parameter is automatically set during the field weakening control optimization run (P051 = 27), and in this case, specifies the reference EMF in the field weakening range.

Note:

The ratio of P118 to P119 is decisive for the field weakening control.

The EMF setpoint in the field weakening range is defined by  $(P101 - P100 * P110)$ . If P100, P101 or P110 are subsequently changed, it is not necessary to repeat the optimization run for field weakening, but P118 no longer specifies the reference EMF in the field weakening range.

If parameter P102 is subsequently changed, the optimization run for field weakening must be repeated, the same is also true when subsequently adjusting the maximum speed.

Factory setting: 340V

Value range (steps): 0 to 1000V (1V)

Access: 40

Change: off-line

**P119 Rated speed (% of the maximum speed)**

(also refer to Section 10.1, Sheet 19)

Speed, at which an EMF actual value according to parameter P118 is obtained at full field (corresponding to parameter P102).

The parameter is automatically set during the field weakening optimization run (P051 = 27), and in this case provides the speed at the start of field weakening.

Note:

The ratio of P118 to P119 is decisive for the field weakening control. If parameters P100, P101 or P110 are subsequently changed, the optimization run for field weakening need not be repeated, however, in this case P119 no longer represents the speed at the start of field weakening. If parameter P102 is subsequently changed, the field weakening optimization run must be repeated, which is also true if the maximum speed is subsequently changed.

Factory setting: 100.0%

Value range (steps): 0.0 to 199.9% (0.1%) of  $n_{max}$

Access: 40

Change: off-line

**P120 Field current for 0% motor flux (field characteristic, point No. 0)**

Factory setting: 0.0% Value range: 0.0%

Access: can only be read

**P121 Field current for 5% motor flux (field characteristic, point No. 1)**

to

**P139 Field current for 95% motor flux (field characteristic, point No. 19)**

Parameters P120 to P139 define the characteristic shape of the magnetizing characteristic (field characteristic) in the normalized representation. P120 to P139 are those field current values (in 0.1% of the rated motor field current, according to P102) which are assigned to a linear motor flux scaling (0% to 95% of the rated max.) motor flux, in 5% steps) (also refer to the subsequent example of a field characteristic).

The last (20th) point of the normalized magnetization characteristic for the field current for 100% motor flux, 100% (of P102), is no longer explicitly available as parameter.

The field characteristic, defined by values P120 to P139 is used in operation to determine the motor flux  $\Phi$  from the field current actual value  $I_f$  (K265) by linearly interpolating between the specific values (for field current actual value  $I_f > 100\%$  of P102, the characteristic is linearly extended to internally calculate the motor flux), and, together with P118 and P119, to determine a pre-control value (field current setpoint) for the EMF controller (also refer to Section 10.1, Sheets 19 and 20).

The motor flux  $\Phi$ , for P170 = 1x is required to calculate the torque limits, and for P170 = x1, to convert the torque setpoint into an armature current setpoint (also refer to Section 10.1, Sheet 17).

Parameters P120 to P139 are automatically set during the optimization run for field weakening (P051 = 27).

Note:

If parameter P102 is subsequently changed, the optimization run for field weakening must be repeated, as in this case, the degree of saturation, and thus the shape of the normalized magnetization characteristic changes (if parameters P100, P101, P110, or the maximum speed adjustment are subsequently changed, P120 to P130 remain, however, the values of P118 and/or P119 change).

|                  |              |              |              |              |
|------------------|--------------|--------------|--------------|--------------|
| Factory setting: | P120 = 0.0%  | P121 = 3.7%  | P122 = 7.3%  | P123 = 11.0% |
|                  | P124 = 14.7% | P125 = 18.4% | P126 = 22.0% | P127 = 25.7% |
|                  | P128 = 29.4% | P129 = 33.1% | P130 = 36.8% | P131 = 40.6% |
|                  | P132 = 44.6% | P133 = 48.9% | P134 = 53.6% | P135 = 58.9% |
|                  | P136 = 64.9% | P137 = 71.8% | P138 = 79.8% | P139 = 89.1% |

Value range (steps): 0.0 to 100.0% of the motor rated field current (0.1%)

Access: 40

Change: off-line

### Example of a field characteristic

This has a stronger curvature (i.e., a lower iron saturation level), than the field characteristic according to the factory setting.

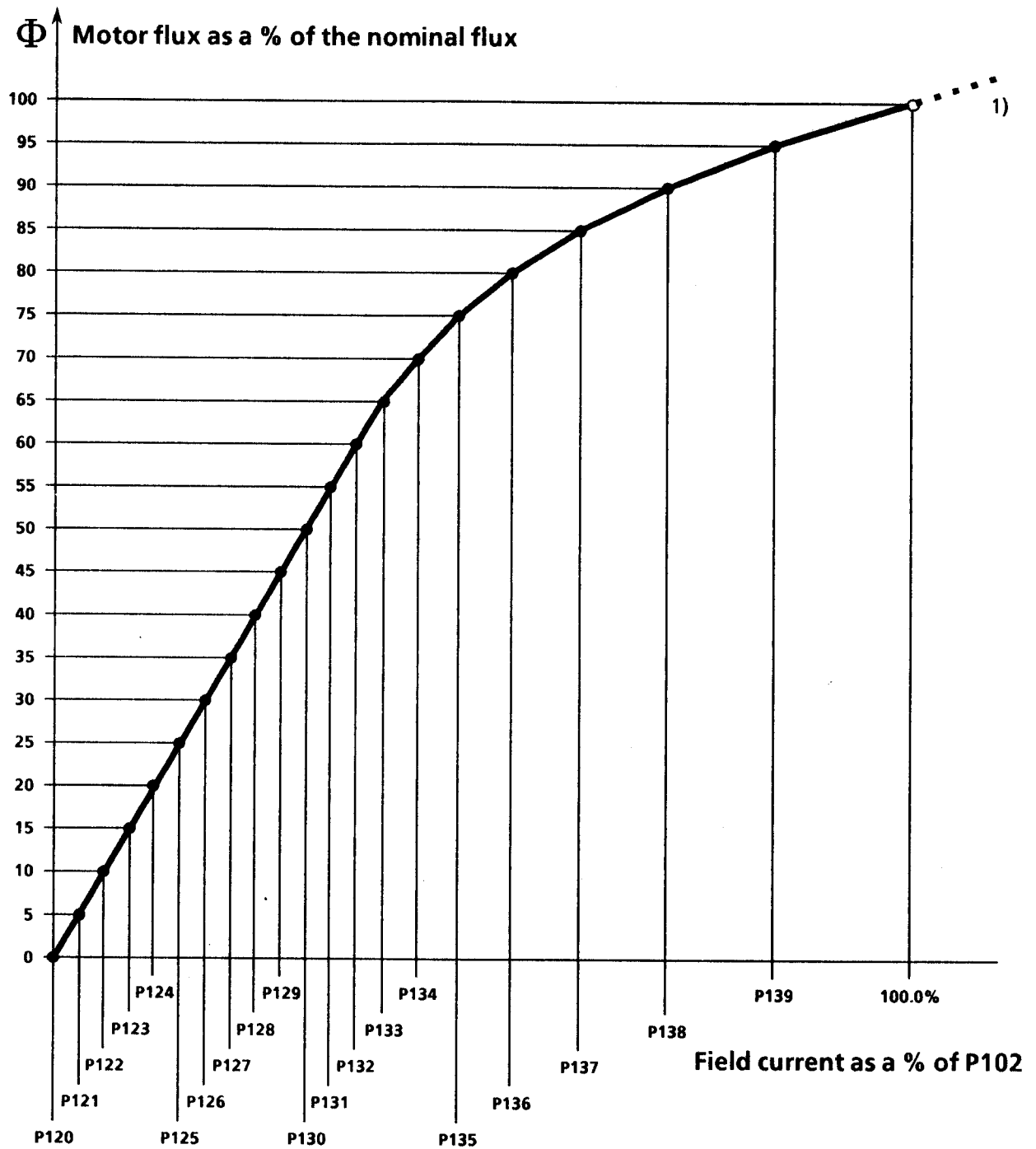

- 1) The characteristic to internally calculate the motor flux is linearly extended for field current actual values  $I_f > 100\%$  of P102.

# Pulse encoder definition

## P140 Pulse encoder type

- 0 No encoder/"speed sensing with pulse encoder" function not selected
- 1 Pulse encoder, type 1  
Encoder with two pulse trains which are displaced through 90° (with/without zero mark)

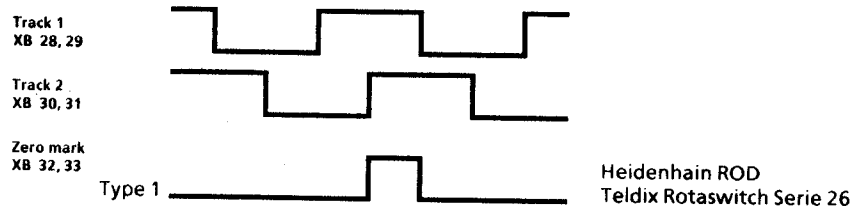

- 2 Pulse encoder, type 1a  
Encoder with 2 pulse tracks displaced through 90° (with/without zero mark). The zero mark is internally converted to a signal as for encoder, type 1.

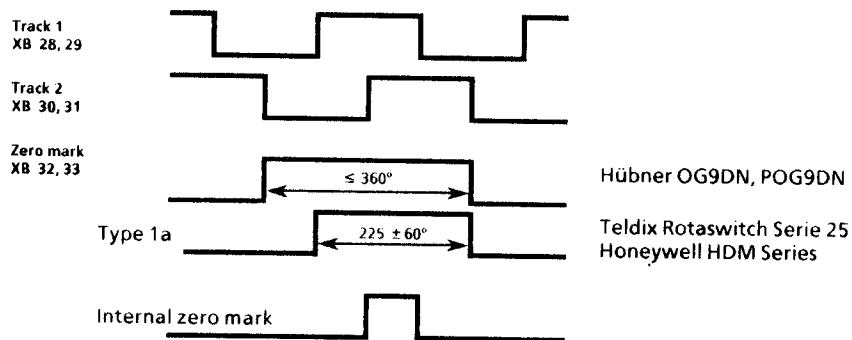

- 3 Pulse encoder, type 2  
Encoder with one pulse track per direction of rotation (with/without zero mark).

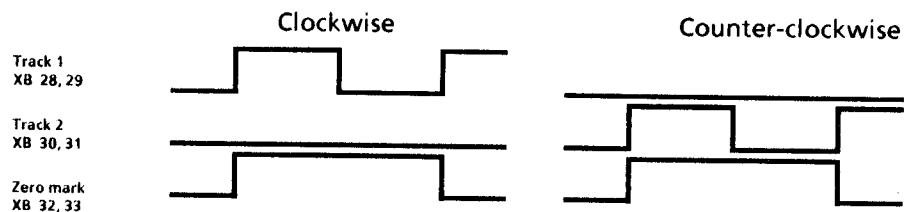

- 4 Pulse encoder, type 3  
Encoder with a pulse track and output for the direction of rotation (with/without zero mark).

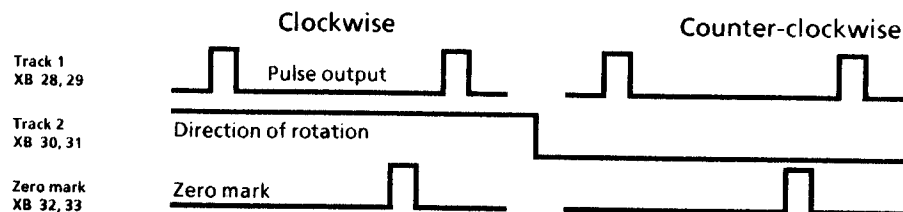

Factory setting: 0

Access: 20

Value range: 0 to 4

Change: off-line

**P141 Pulse encoder, pulse number**

Information to select a pulse encoder:

The lowest speed which can be measured using a pulse encoder is obtained as follows

$$n_{\min} [\text{RPM}] = 14648 * \frac{1}{X * P141}$$

where:

- X = 1 for 1x evaluation of the pulse encoder signals (P142 = xx0)  
 2 for 2x evaluation of the pulse encoder signals (P142 = xx1)  
 4 for 4x evaluation of the pulse encoder signals (P142 = xx2)  
 also refer to "multiple evaluation of the encoder pulses"

Lower speeds are evaluated as n = 0.

The frequency of the pulse encoder signals at terminals 28 and 29 or 30 and 31 must not exceed 300 kHz.

The highest speed which can be measured using a pulse encoder is obtained as follows:

$$n_{\max} [\text{RPM}] = \frac{18\,000\,000}{P141}$$

When selecting the pulse encoder, it must be observed, that the lowest occurring speed  $\neq 0$  is significantly above  $n_{\min}$  and the highest occurring speed, is not above  $n_{\max}$ .

Thus:

$$IM \gg \frac{14648}{X * n_{\min} [\text{RPM}]}$$

$$IM \leq \frac{18\,000\,000}{n_{\max} [\text{RPM}]}$$

To select the pulse number IM (pulses/revolution) of the pulse encoder.

Factory setting: 500 pulses/rev.

Value range (steps): 1 to 32767 pulses/rev. (1 pulse/rev.)

Access: 20

Change: off-line

**P142 Control word for the pulse encoder****Multiple evaluation of the encoder signals**

- xx0 1x evaluation of the pulse encoder signals  
 xx1 2x evaluation of the pulse encoder signals (for encoder types 1, 1a and 2)  
 xx2 4x evaluation of the pulse encoder signals (for encoder types 1 and 1a)

**Automatic measuring range changeover for measurements at low speeds**

- x0x Automatic changeover to count frequency OFF  
 x1x Automatic changeover to count frequency ON  
 0xx Automatic changeover, multiple pulse encoder signal evaluation OFF  
 1xx Automatic changeover, multiple pulse encoder signal evaluation ON

**Caution:**

When the multiple evaluation of the encoder pulses are changed over, this affects the measuring channel for position sensing. Thus, this function cannot be used for positioning. Connectors K013 and K014 are invalid for P142 = 1xx!

Factory setting: 002

Value range (steps): 000 to 112 (1 hex)

Access: 20

Change: off-line

**P143 Maximum speed for pulse encoder operation (rough)**

When using the speed actual value from the pulse encoder (P083 = 2), the maximum speed is defined with parameters P143 and P452. The speed actual value from the pulse encoder is normalized with parameters P143 and P452, i.e., the speed set using these parameters corresponds to a speed actual value (K011, K012) of 100%. The values of parameters P143 and P452 are added.

Factory setting: 500 RPM

Value range (steps): 1 to 10000 RPM (1 RPM)

Access: 20

Change: on-line

**P144 Control word for position sensing**

from SW1.10

- xx0 Positioning counter, reset off
- xx1 Positioning counter, reset using zero mark
- xx2 Positioning counter, reset using zero mark, if low signal at terminal 39
- xx3 Positioning counter, reset LOW signal at terminal 39
  
- x0x Hysteresis for direction of rotation reversal OFF
- x1x Hysteresis for direction of rotation reversal ON (after a direction change, the first pulse encoder input pulse is not counted)
  
- 0xx Pulse encoder monitoring OFF (F048 is not initiated due to a defective pulse encoder)
- 1xx Pulse encoder monitoring ON (hardware monitoring of the pulse encoder signals for non-plausible behavior (frequent speed change, edges too close together, encoder conductor open-circuit or short-circuit between two encoder conductors) can cause F048 to be initiated.

Factory setting: 111

Value range (steps): 000 to 113 (1 hex)

Access: 20

Change: off-line

**Definition of the "motor interface" option****P145 Control parameter for the "motor interface" option**

(also refer to the terminal assignment, motor interface - motor terminals, in Section 6.9)

**Brush length sensing**

- xxx0 No brush length sensing
- xxx1 Binary brush length sensing (terminal XM-211)  
Alarm (W02) at 0 signal
- xxx2 Binary brush length sensing (terminal XM-211)  
Fault message (F115) at 0 signal
- xxx3 Analog brush length sensing (terminal XM-202)  
Alarm (W02) for brush length  $\leq$  14mm  
Fault message (F115) for brush length  $\leq$  12mm

**Bearing condition**

- xx0x No bearing condition sensing (terminal XM-212 is not interrogated)
- xx1x Bearing condition sensing (terminal XM-212 is interrogated)  
Alarm (W03) at 1 signal
- xx2x Bearing condition sensing (terminal XM-212 is interrogated)  
1 signal indicates a fault signal (F116)

**Airflow**

- x0xx No airflow monitoring (terminal XM-213 is not interrogated)
- x1xx Airflow monitoring (terminal XM-213 is interrogated)  
Alarm (W04) at 0 signal
- x2xx Airflow monitoring (terminal XM-213 is interrogated)  
0 signal indicates a fault signal (F117)

**Thermo switch**

0xxx Thermo switch not connected (terminal XM-214 is not interrogated)  
 1xxx Thermo switch connected (terminal XM-214 is interrogated)  
 0 signal indicates an alarm (W05)  
 2xxx Thermo switch connected (terminal XM-214 is interrogated)  
 0 signal indicates a fault signal (F118)

Factory setting: 0000

Value range (steps): 0000 to 2223 (1 hex)

Access: 20

Change: off-line

**P146 Selecting the temperature sensor for the "motor interface" option  
 (connected at terminals XM-204 and XM-205)**

(also refer to the terminal assignment, motor interface-motor terminals, in Section 6.9)

|    | Temperature sensor                         | Plug-in jumper XJ101 on the A1617 PC board in position | Response when the nominal response temperature is exceeded          |
|----|--|--|---|
| 0  | None                                       | any  | Terminal is not interrogated  |
| 1  | KTY84                                      | 1 - 2  | Alarm W06 at temperature >P147<br>Fault message F119 at temp. >P148 |
| 2  | PT100                                      | 2 - 3  | Alarm W06 at temperature >P147<br>Fault message F119 at temp. >P148 |
| 3  | PTC therm. <sup>1)</sup><br>with R = 600Ω  | 1 - 2  | Alarm W06   |
| 4  | PTC therm. <sup>1)</sup><br>with R = 600Ω  | 1 - 2  | Fault message F119  |
| 5  | PTC therm. <sup>1)</sup><br>with R = 1200Ω | 1 - 2  | Alarm W06   |
| 6  | PTC therm. <sup>1)</sup><br>with R = 1200Ω | 1 - 2  | Fault message F119  |
| 7  | PTC therm. <sup>1)</sup><br>with R = 1330Ω | 1 - 2  | Alarm W06   |
| 8  | PTC therm. <sup>1)</sup><br>with R = 1330Ω | 1 - 2  | Fault message F119  |
| 9  | PTC therm. <sup>1)</sup><br>with R = 2660Ω | 1 - 2  | Alarm W06   |
| 10 | PTC therm. <sup>1)</sup><br>with R = 2660Ω | 1 - 2  | Fault message F119  |

<sup>1)</sup> PTC thermistor acc. to DIN 44081 / 44082 with R at the nominal response temperature, for Siemens motors, 2660Ω (setting 9 or 10 should be selected)

Factory setting: 0

Value range: 0 to 10

Access: 20

Change: off-line



**P147 Alarm temperature**

Only effective if the analog motor temperature sensing is selected (P146 in setting 1 or 2).

Factory setting: 0°C                      Value range (steps): 0 to 200°C (1°C)  
0 = no alarm

Access: 20                                      Change: on-line

**P148 Shutdown temperature**

Only effective if the analog motor temperature sensing is selected (P146 in setting 1 or 2).

Factory setting: 0°C                      Value range (steps): 0 to 200°C (1°C)  
0 = no fault

Access: 20                                      Change: on-line

**Closed-loop control optimization****Settings for the armature current control****P150 Alpha G limit (armature)**

(also refer to Section 10.1, Sheet 18)

Rectifier stability limit for the armature converter firing angle.

Factory setting:     5 for 1Q converters  
                          30 for 1Q converters

Value range (steps): 0 to 165 degrees (1 degree)

Access: 30                                      Change: on-line

**P151 Alpha W limit (armature)**

(also refer to Section 10.1, Sheet 18)

Inverter stability limit for the armature converter firing angle.

This firing angle limiting is only effective for continuous armature current. For discontinuous armature current, the firing angle is limited to 165 degrees.

Factory setting: 150 degrees              Value range (steps): 120 to 165 degrees (1 degree)

Access: 30                                      Change: off-line

**P152 Filtering the supply frequency tracking (armature)**

(also refer to Section 10.1, Sheet 18)

The internal supply synchronization for the armature firing pulses, derived from the power connection (armature supply infeed), is filtered with this time constant. For operation from "weak", frequency-unstable supplies, e.g. when supplied from a Diesel generator (island operation), the filter time constant must be parameterized for a lower value than for operation on "stiff" supplies in order to achieve a higher frequency tracking speed.

Factory setting: 200ms                      Value range (steps): 0 to 200ms (1ms)

Access: 40                                      Change: on-line

**P153 Control word, armature pre-control**

(also refer to Section 10.1, Sheet 18)

- 0 Armature pre-control inhibited, pre-control output = 165° from SW2.00 (180°, up to and including SW1.30)
- 1 Armature pre-control active, output is dependent on the EMF actual value, armature current setpoint, supply voltage (armature), supply frequency (armature), P110, P111
- 2 Armature pre-control is calculated for EMF = 0, current controller integrator is set, for torque direction change, to the difference, pre-control (EMF) - pre-control (EMF = 0)  
Should be set when supplying high inductances from the armature terminals, e.g. lifting solenoids, field supply) from SW2.00

Factory setting: 1

Value range: 0 to 2

Access: 20

Change: off-line

**P154 Control word, armature current controller**

(also refer to Section 10.1, Sheet 18)

- x0 Set controller I component to zero (i.e. pure P controller)
- x1 Controller I component, active
- 0x Set controller P component to zero (i.e. pure I control)
- 1x Controller P component active

Factory setting: 11

Value range (steps): 00 to 11 (1 hex)

Access: 20

Change: off-line

**P155 Armature current controller, P gain**

(also refer to Section 10.1, Sheet 18)

Armature current controller proportional gain

The parameter is automatically set during the optimization run for the pre-control and current controller for armature and field (P051 = 25).

Factory setting: 0.10

Value range (steps): 0.01 to 10.00 (0.01)

0.01 to 200.00 (0.01) from SW2.00

Access: 20

Change: on-line

**P156 Armature current controller, integral action time**

(also refer to Section 10.1, Sheet 18)

The parameter is automatically set during the optimization run for the pre-control and current controller for armature and field (P051 = 25)

Factory setting: 0.200s

Value range (steps): 0.001 to 1.000s (0.001s)

0.001 to 10.000s (0.001) from SW2.00

Access: 20

Change: on-line

**P157 Control word, current setpoint integrator**

from SW2.00

(also refer to Section 10.1, Sheet 18)

- 0 Reduced gearbox stressing  
The integrator is only effective after a torque direction change (it only acts as ramp-function generator for the armature current setpoint, until the output reaches the setpoint at the integrator input for the 1st time after a torque direction change).
- 1 Current setpoint integrator  
The integrator is always effective (acts as ramp-function generator for the armature current setpoint).

Factory setting: 0

Value range (steps): 0 to 1

Access: 20

Change: on-line

**P158 Ramp-up time for the current setpoint integrator (reduced gearbox stressing)**

(also refer to Section 10.1, Sheet 18)

The time to ramp-up for a setpoint jump of 0% to 100% of P072.

P157 should be set to 1 and P158 to 0.040 for older machines.

Factory setting: 0.000s

Value range (steps): 0.000 to 0.100s (0.001s)

Access: 20

Change: on-line

**P159 Changeover threshold for the auto-reversing stage (armature)**

(also refer to Section 10.1, Sheet 18)

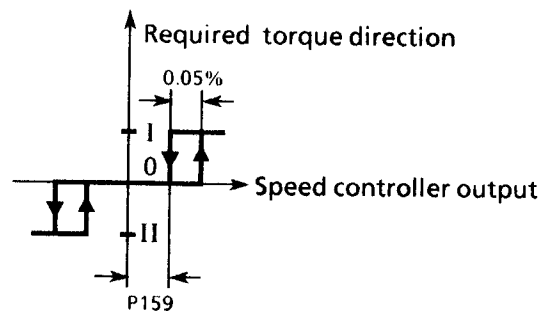

Factory setting: 0.01%

Value range (steps): 0.00 to 100.00% of the speed controller output (0.01%)

Access: 30

Change: on-line

**P160 Additional torque-free interval**

from SW2.00

(also refer to Section 10.1, Sheet 18)

Additional torque-free interval for torque direction change for 4Q operation.

This parameter should be set, especially when supplying large inductances (e.g. supplying hoisting solenoids), to values  $>0$ .

Factory setting: 0.000s

Value range: 0.000 to 2.000s

Access: 20

Change: on-line

## Settings for the current- and torque limiting

### **P170 Torque control/current control selection**

(also refer to Section 10.1, Sheet 17)

- x0 Torque control disabled (= current control)
- x1 Torque control active (current setpoint = torque setpoint/motor flux)
- 0x "Torque limiting" acts as current limiting
- 1x Torque limiting active (divided by the motor flux)

Note:

For P170 = 1x or x1, a valid field characteristic must be present (P117 = 1), otherwise, the optimization run for field weakening (P051 = 276) must be executed.

Factory setting: 10                      Value range (steps): 00 to 11 (1 hex)

Access: 20                                Change: off-line

### **P171 System current limiting in torque direction I**

(also refer to Section 10.1, Sheet 17)

Factory setting: 100.0%

Value range (steps): 0.0 to 300.0% rated motor armature current (0.1%)

Access: 20                                Change: on-line

### **P172 System current limiting in torque direction II**

(also refer to Section 10.1, Sheet 17)

Factory setting: -100.0%

Value range (steps): -300.0 to 0.0% rated motor armature current (0.1%)

Access: 20                                Change: on-line

### **P180 Positive torque limit 1**

(also refer to Section 10.1, Sheet 17)

Factory setting: 300.00%

Value range (steps): -300.0 to 300.00% of the rated motor torque (0.01%)

Access: 20                                Change: on-line

### **P181 Negative torque limit 1**

(also refer to Section 10.1, Sheet 17)

Factory setting: -300.0%

Value range (steps): -300.0 to 300.00% of the rated motor torque (0.01%)

Access: 20                                Change: on-line

**P182 Positive torque limit 2**

(also refer to Section 10.1, Sheet 17 and 10.3.42)

A changeover is made from torque limit 1 to torque limit 2 if the torque limit changeover is selected (binary input function BEF42 = 1), and the speed is greater than the changeover speed, set at parameter P184.

Factory setting: 300.00%

Value range (steps): -300.0 to 300.00% motor rated torque (0.01%)

Access: 20

Change: on-line

**P183 Negative torque limit 2**

(also refer to Section 10.1, Sheet 17 and 10.3.42)

A changeover is made from torque limit 1 to torque limit 2 if the torque limit changeover is selected (binary input function BEF42 = 1), and the speed is greater than the changeover speed, set at parameter P184.

Factory setting: -300.0%

Value range (steps): -300.0 to 300.00% motor rated torque (0.01%)

Access: 20

Change: on-line

**P184 Changeover speed for the torque limits**

(also refer to Section 10.1, Sheet 17 and 10.3.42)

A changeover is made from torque limit 1 (P180, P181) to torque limit 2 (P182, P183), if the torque limit changeover is selected (binary input function BEF42 = 1), and if the speed (166) is greater than the changeover speed, selected with parameter P184.

Factory setting: 0.00%

Value range (steps): 0.00 to 120.00% of the maximum speed (0.01%)

Access: 20

Change: on-line

**Settings for the speed controller actual value conditioning****P200 Filter time for the speed controller actual value**

(also refer to Section 10.1, Sheet 15)

The speed actual value is filtered through a PT1 element.

This filter is taken into account by the speed controller optimization run (P051 = 26).

Factory setting: 0 ms

Value range (steps): 0 to 10000 ms (1 ms)

Access: 20

Change: on-line

**P201 Resonant frequency of the first band-stop filter from SW1.10**

(also refer to Section 10.1, Sheet 15)

The actual value after the PT1 element is fed through two band-stop filters which can be parameterized. Resonant frequency of the first band-stop filter.

0 Band-stop filter switched-out  
 11 to 140Hz Resonant frequency  
 1 to 10 Band-stop filter is calculated for a 10 Hz resonant frequency  $\leq$ SW1.30

Factory setting: 0Hz Value range (steps): 0 to 140Hz (1Hz)

Access: 20 Change: on-line

**P202 Quality of the first band-stop filter from SW1.10**

(also refer to Section 10.1, Sheet 15)

The actual value after the PT1 element is fed through two band-stop filters which can be parameterized. Quality of the first band-stop filter.

0 Quality = 0.5  
 1 Quality = 1  
 2 Quality = 2  
 3 Quality = 3

Factory setting: 0 Value range: 0 to 3

Access: 20 Change: on-line

**P203 Resonant frequency of the 2nd band-stop filter from SW1.10**

(also refer to Section 10.1, Sheet 15)

The actual value after the PT1 element is fed through two band-stop filters which can be parameterized. Resonant frequency of the second band-stop filter.

0 Band-stop filter switched-out  
 11 to 140Hz Resonant frequency  
 1 to 10 Band-stop filter is calculated for a 10 Hz resonant frequency  $\leq$ SW1.30

Factory setting: 0Hz Value range (steps): 0 to 140Hz (1Hz)

Access: 20 Change: on-line

**P204 Quality of the second band-stop filter from SW1.10**

(also refer to Section 10.1, Sheet 15)

The actual value after the PT1 element is fed through two band-stop filters which can be parameterized. Quality of the second band-stop filter.

0 Quality = 0.5  
 1 Quality = 1  
 2 Quality = 2  
 3 Quality = 3

Factory setting: 0 Value range: 0 to 3

Access: 20 Change: on-line

**P205 Derivative action time for the D component in the speed controller actual value channel** **from SW1.10**

(also refer to Section 10.1, Sheet 15)

After filtering and after the band-stop filter, the actual value is fed through a D component which can be parameterized.

Factory setting: 0ms

Value range (steps): 0 to 1000ms (1ms)

Access: 20

Change: on-line

**Settings for the speed controller**

**P220 Speed controller, integrator setting value 1**

(also refer to Section 10.1, Sheet 15)

The speed controller integrator is set in operating status >01 (no controller enable), to the value in parameter P220.

Factory setting: 0.0%

Value range (steps): -100.0 to 100.0% of the speed controller output (0.1%)

Access: 20

Change: off-line

**P222 Changeover threshold, PI/P controller**

(also refer to Section 10.1, Sheet 15 and 10.3.38)

- 0.00 Automatic changeover from PI- to P controller disabled
- >0.00 Dependent on the speed actual value (K166), a changeover is made from the PI- to P controller, if the speed, set using parameter P222, is fallen below. The integrator is only re-enabled at a speed actual value  $>P222 + 2\%n_{max}$  (with value zero). This function allows the drive to be shutdown without oscillation via setpoint = 0 with the controllers enabled. If the binary input function "PI/P speed controller changeover enable" (BEF38), was assigned a terminal or a bit of the freely-definable control word STWF, then the speed actual value-dependent changeover from PI- to P controllers, is only effective when the input is energized (BEF38 = 1).

Factory setting: 0.00%

Value range (steps): 0.00 to 10.00% maximum speed (0.01%)

Access: 20

Change: on-line

**P223 Control word, speed controller pre-control** **from SW1.10**

(also refer to Section 10.1, Sheet 15)

- 0 Speed controller pre-control inhibited
- 1 Speed controller pre-control acts as torque setpoint (is added to the speed controller output)

Factory setting: 0

Value range: 0 to 1

Access: 20

Change: off-line

**P224 Control word, speed controller**

(also refer to Section 10.1, Sheet 15)

|      |   |
|------|---|
| xxx0 | Set controller I component to zero (i.e pure P controller)      |
| xxx1 | Controller I component active                                   |
| xx0x | Set the controller P component to zero (i.e. pure I controller) |
| xx1x | Controller P component active                                   |
| x0xx | The setpoint is switched-in with the correct sign               |
| x1xx | The setpoint is switched-in, inverted                           |
| 0xxx | The actual value is switched-in with the correct sign           |
| 1xxx | The actual value is switched-in, inverted                       |

Factory setting: 0011

Value range (steps): 0000 to 1111 (1 hex)

Access: 20

Change: off-line

**P225 Speed controller, P gain**

(also refer to Section 10.1, Sheet 15)

Also refer to the settings for the speed controller adaption function (P550 to P561).  
The parameter is automatically set during the speed controller optimization run (P051 = 26).

Factory setting: 3.00

Value range (steps): 0.10 to 200.00 (0.01)

Access: 20

Change: on-line

**P226 Speed controller, integral-action time**

(also refer to Section 10.1, Sheet 15)

Also refer to the settings for the speed controller adaption function (P550 to P561).  
The parameter is automatically set during the speed controller optimization run (P051 = 26).

Factory setting: 0.650s

Value range (steps): 0.010 to 10.000s (0.001s)

Access: 20

Change: on-line

**P227 Speed controller, droop**

(also refer to Section 10.1, Sheet 15 and 10.3.37)

Also refer to the settings for the speed controller adaption function (P550 to P561). A feedback element which can be parameterized is connected in parallel to the I- and P component of the speed controller (acts on the summing point of the setpoint and actual value). If the binary input function "enable speed controller droop" (BEF37), was assigned a terminal or a bit of the freely-definable STW control word, then this feedback can be switched-in and out via this input. If no input is parameterized as "enable speed controller droop" the feedback is always effective (switched-out with parameter value = 0). 10% droop setting means that the speed actual value deviates from the setpoint by 10% at 100% controller output (100% torque- or armature current setpoint).

Factory setting: 0.0%

Value range (steps): 0.0 to 10.0% of the rated converter torque (0.1%)

Access: 20

Change: on-line



**P228 Filter time for the speed controller setpoint**

(also refer to Section 10.1, Sheet 15)

Filtering the setpoint through a PT1 element.

The parameter is automatically set during the speed controller optimization run (P051 = 26), the same as the speed controller integral action time.

When a ramp-function generator is used, it can be practical to parameterize the parameter for lower values.

Factory setting: 0ms

Value range (steps): 0 to 10000ms (1ms)

Access: 20

Change: on-line

**P229 Speed controller mode for slave drive operation****from SW2.00**

(also refer to Section 10.1, Sheet 15 and 10.3.41)

0 For P084 = 2 (closed-loop current/torque control), or when "slave operation" is selected via binary input function BEF41, the speed controller is inhibited.

1 For P084 = 2 (closed-loop current/torque control), or when "slave operation" is selected via binary input function BEF41, the speed controller is enabled.

Factory setting: 0

Value range: 0 to 1

Access: 20

Change: off-line

**Settings for the field current controller****P250 Alpha G limit (field)**

(also refer to Section 10.1, Sheet 20)

Rectifier stability limit for the field converter firing angle.

Factory setting: 0 degrees

Value range (steps): 0 to 180 degrees (1 degree)

Access: 30

Change: off-line

**P251 Alpha W limit (field)**

(also refer to Section 10.1, Sheet 20)

Inverter stability limit for the field converter firing angle.

Factory setting: 180 degrees

Value range (steps): 0 to 180 degrees (1 degree)

Access: 30

Change: off-line

**P252 Filter the supply frequency tracking (field)**

(also refer to Section 10.1, Sheet 20)

The internal line supply synchronization for the field firing pulses, derived from the field supply incoming terminals, is filtered with this time constant. For operation from "weak", frequency-unstable supplies, e.g. from diesel generators (island operation), the filter time constant must be parameterized lower than for operation from "stiff" supplies, in order to achieve a higher frequency tracking speed.

Factory setting: 200ms

Value range (steps): 0 to 200ms (1ms)

Access: 40

Change: on-line

**P253 Control word, field pre-control**

(also refer to Section 10.1, Sheet 20)

- 0 Field pre-control inhibited, pre-control output = 180°
- 1 Field pre-control active, output is dependent on the field current setpoint, supply voltage (field), P112

Factory setting: 1 Value range: 0 to 1

Access: 20 Change: off-line

**P254 Control word, field current controller**

(also refer to Section 10.1, Sheet 20)

- x0 Set the controller I component to zero (i.e. pure P controller)
- x1 Controller I component active
- 0x Set the controller P component to zero (i.e. pure I controller)
- 1x Controller P component active

Factory setting: 11 Value range (steps): 00 to 11 (1 hex)

Access: 20 Change: off-line

**P255 Field current controller, P gain**

(also refer to Section 10.1, Sheet 20)

The parameter is automatically set during the optimization run for pre-control and current controller for armature and field (P051 = 25)

Factory setting: 5.00 Value range (steps): 0.01 to 100.00 (0.01)

Access: 20 Change: on-line

**P256 Field current controller, integral-action time**

(also refer to Section 10.1, Sheet 20)

The parameter is automatically set during the optimization run for pre-control and current controller for armature and field (P051 = 25)

Factory setting: 0.200s Value range (steps): 0.001 to 10.000s (0.001s)

Access: 20 Change: on-line

**P257 Standstill field**

(also refer to Section 10.1, Sheet 20 and 10.3.92)

Value, to which the field current is reduced when the "automatic field current reduction" function is parameterized (with P082 = xx2), or for signal-controlled selection of the binary input function "standstill field" (BEF56 = 1).

Factory setting: 0.0%

Value range (steps): 0.0 to 100.0% of the rated motor field current, P102 (0.1%)

Access: 20 Change: on-line

**P258 Delay time for automatic field current reduction**

(also refer to Section 10.1, Sheet 20 and 10.3.92)

Time, in which the field current is reduced to the value according to parameter P257 when the drive is shutdown after operating status 07.0 or higher is reached, automatically or with the signal-controlled function "field current reduction".

Factory setting: 10.0s                      Value range (steps): 0.0 to 60.0s (0.1s)  
 Access: 20                                      Change: on-line

**Settings for the EMF control****P273 Control word, EMF controller pre-control**

(also refer to Section 10.1, Sheet 19)

0    EMF controller pre-control inhibited, pre-control output = motor rated field current (P102)  
 1    EMF controller pre-control active

Factory setting: 1                              Value range: 0 to 1  
 Access: 20                                      Change: off-line

**P274 Control word, EMF controller**

(also refer to Section 10.1, Sheet 19)

xxx0    Set controller I comp. to zero (i.e. pure P controller)  
 xxx1    Controller I component active  
 xx0x    Set controller P comp. to zero (i.e. pure I controller)  
 xx1x    Controller P component active  
 x0xx    The setpoint is switched-in with the correct sign  
 x1xx    The setpoint is switched-in, inverted  
 0xxx    The actual value is switched-in with the correct sign  
 1xxx    The actual value is switched-in, inverted

Factory setting: 0011                      Value range (steps): 0000 to 1111 (1 hex)  
 Access: 20                                      Change: off-line

**P275 EMF controller, P gain**

(also refer to Section 10.1, Sheet 19)

From V 2.00 onwards, the parameter is automatically set during the optimization run for field weakening (P051 = 27).

Factory setting: 0.60                      Value range (steps): 0.10 to 100.00 (0.01)  
 Access: 20                                      Change: on-line

**P276 EMF controller, integral-action time**

(also refer to Section 10.1, Sheet 19)

From V2.00 onwards, the parameter is automatically set during the optimization run for field weakening (P051 = 27).

Factory setting: 0.200s                      Value range (steps): 0.010 to 10.000s (0.001s)  
 Access: 20                                      Change: on-line

**P277 EMF controller, droop**

(also refer to Section 10.1, Sheet 19)

Factory setting: 0.0%

Value range (steps): 0.0 to 10.0% (0.1%)

Access: 20

Change: on-line

**Ramp-function generator settings****P300 Positive limit for the ramp-function generator output**

(also refer to Section 10.1, Sheet 14)

The speed setpoint is limited, with sign (it is possible to set a negative minimum speed).

Factory setting: 100.00%

Value range (steps): -200.0 to 199.99% of the max. speed (0.01%)

Access: 20

Change: on-line

**P301 Negative limit for the ramp-function generator output**

(also refer to Section 10.1, Sheet 14)

The speed setpoint is limited, with sign (it is possible to set a positive minimum speed).

Factory setting: -100.0%

Value range (steps): -200.0 to 199.99% of the max. speed (0.01%)

Access: 20

Change: on-line

**P302 Control word, ramp-function generator**

(also refer to Section 10.1, Sheet 14, 10.3.31 and 10.3.32)

x0 No ramp-function generator tracking

from SW2.00

x1 Ramp-function generator tracking active

from SW2.00

Mode of operation of the ramp-function generator tracking:

The ramp-function generator output (K190), is limited to the following values when the ramp-function generator tracking is active:

$$\frac{-M_{limit} * 1.25}{Kp} + n_{act} < \text{RFG output} < \frac{+M_{limit} * 1.25}{Kp} + n_{act}$$

for P170 = x1 (torque control) the following is valid:

$$\frac{-I_{A, limit} * \Phi_{motor} * 1.25}{Kp} + n_{act} < \text{RFG output} < \frac{+I_{A, limit} * \Phi_{motor} * 1.25}{Kp} + n_{act}$$

for P170 = x0 (current control) the following is valid:

$$\frac{-I_{A, \text{limit}} * 1.25}{K_p} + n_{\text{act}} < \text{RFG output} < \frac{+I_{A, \text{limit}} * 1.25}{K_p} + n_{\text{act}}$$

|                         |   |
|-------------------------|---|
| $\Phi_{\text{motor}}$   | Normalized motor flux (1 for rated field current) |
| $n_{\text{act}}$        | Speed actual value (K167)                         |
| + $M_{\text{limit}}$    | Lowest positive torque limit (K143)               |
| - $M_{\text{limit}}$    | Lowest negative torque limit (K144)               |
| + $I_{A, \text{limit}}$ | Lowest positive current limit (K131)              |
| - $I_{A, \text{limit}}$ | Lowest negative current limit (K132)              |
| $K_p$                   | Effective speed controller gain                   |

+ 1% or -1% is added if the value added to  $n_{\text{act}}$ , is less than 1% as absolute value.

The "ramp-function generator tracking" function, is used to ensure that the ramp-function generator does not integrate too far away from the speed actual value, if the torque- or current limit has been reached.

Note:

If the ramp-function generator tracking function is active, the filter time of the speed setpoint P228 should be very low (preferably 0).

Note:

Refer to P629 for ramp-function generator setting.

- 0x Standard ramp-function generator operation.  
The ramp-function generator setting 1 (P303 to P306) is used. When a binary select input is parameterized as a "ramp-function generator 2 (P307 to P310)" (BEF31) or "ramp-function generator setting 3 (P311 to P314)" (BEF32), the appropriate ramp-function generator setting 2 or 3 is used.
- 1x Ramp-up integrator operation: After the setpoint is reached for the first time, changeover from ramp-function generator setting 1 to ramp-generator times = 0
- 2x Ramp-up integrator operation: After the setpoint has been reached for the first time, changeover from ramp-function generator setting 1 to ramp-function generator setting 2 (P307 to P310)
- 3x Ramp-up integrator operation: After the setpoint has been reached for the first time, changeover from ramp-function generator setting to ramp-function generator setting 3 (P311 to P314)

Ramp-up integrator function:

If this function is activated by P302 = 1x, 2x or 3x, ramp-function generator setting 1 (P303 to P306) is first used after an "ON" command (switch-on, "inching", "crawl"). When the ramp-function generator output reaches, for the first time, the required setpoint after an "ON" command, a changeover is made to the ramp-function generator setting, selected according to P302.

The drive is shutdown via ramp-function generator setting 1 when the "shutdown" command is issued.

Note:

When a binary select input, parameterized as "ramp-function generator setting 2 (P307 to P310)" (BEF31) or "ramp-function generator setting 3 (P311 to P314)" (BEF32) is activated, then the thus activated ramp-function generator setting has priority over that, requested with the "ramp-up integrator" function.

Factory setting: 00

Value range (steps): 00 to 31 (1hex)

Access: 20

Change: off-line

Mode of operation of the ramp-function generator, definition of the ramp-function generator times

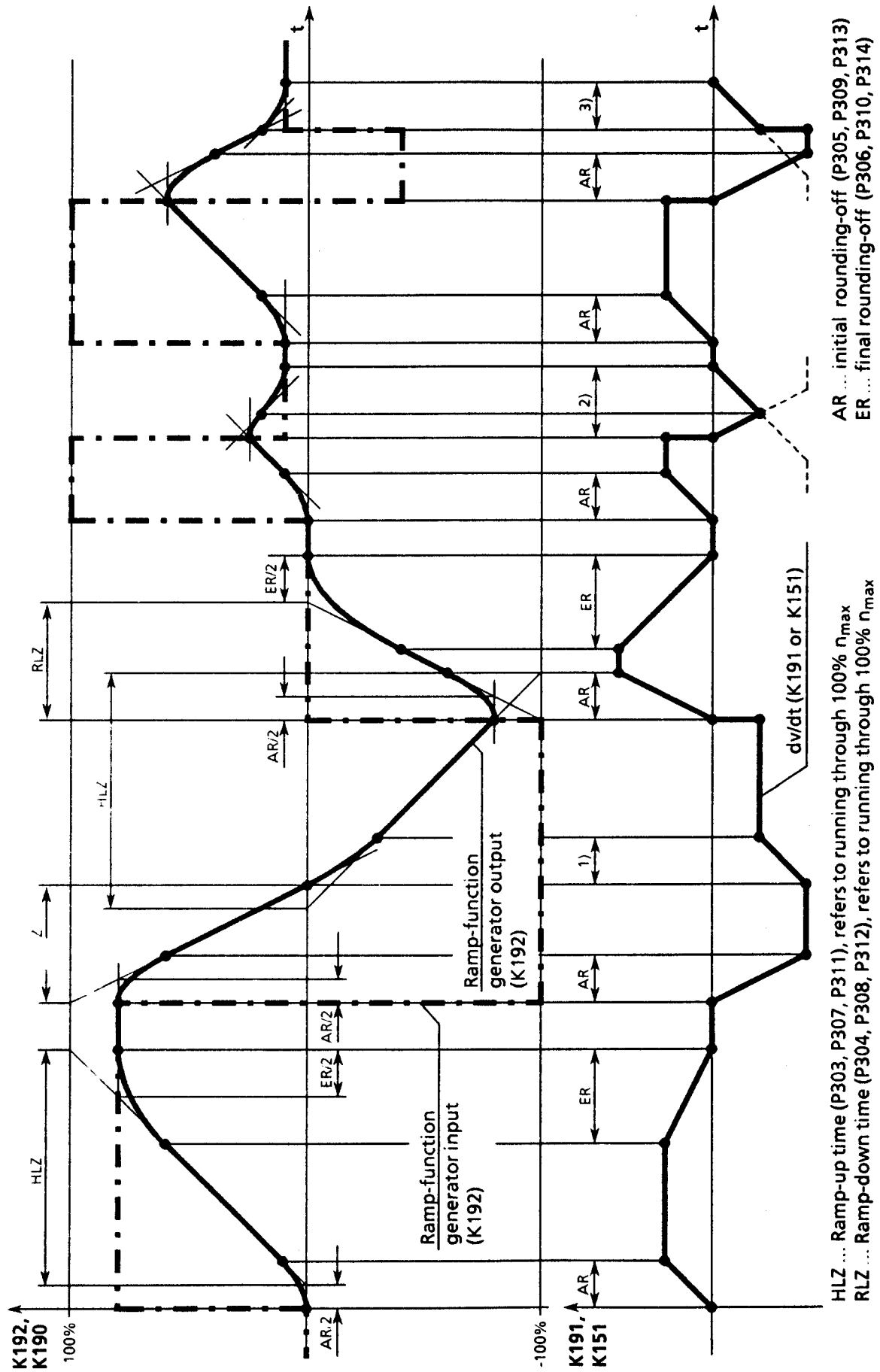

AR ... initial rounding-off (P305, P309, P313)  
ER ... final rounding-off (P306, P310, P314)

HLZ ... Ramp-up time (P303, P307, P311), refers to running through 100%  $n_{max}$   
RLZ ... Ramp-down time (P304, P308, P312), refers to running through 100%  $n_{max}$

- 1) Linear transition from the ramp-down gradient to the ramp-up gradient
- 2) The initial rounding-off blends into the final rounding-off before the maximum ramp-down gradient is reached.
- 3) Only the last section of the final-rounding-off is executed due to the ramp-function generator input step

**Ramp-function generator, parameter set 1**

(also refer to the "mode of operation of the ramp-function generator" for P302)

**P303 Ramp-up time 1**

(also refer to Section 10.1, Sheet 14, 10.3.31 and 10.3.32)

|                        |                      |                         |             |
|------------------------|----------------------|-------------------------|-------------|
| Factory setting: 0.00s | Value range (steps): | 0.00 to 300.00s (0.01s) |             |
|                        |                      | 0.00 to 650.00s         | from SW2.00 |
| Access: 20             | Change: on-line      |                         |             |

**P304 Ramp-down time 1**

(also refer to Section 10.1, Sheet 14, 10.3.31 and 10.3.32)

|                        |                      |                         |             |
|------------------------|----------------------|-------------------------|-------------|
| Factory setting: 0.00s | Value range (steps): | 0.00 to 300.00s (0.01s) |             |
|                        |                      | 0.00 to 650.00s         | from SW2.00 |
| Access: 20             | Change: on-line      |                         |             |

**P305 Initial rounding-off 1**

(also refer to Section 10.1, Sheet 14, 10.3.31 and 10.3.32)

|                        |                      |                        |
|------------------------|----------------------|------------------------|
| Factory setting: 0.00s | Value range (steps): | 0.00 to 10.00s (0.01s) |
| Access: 20             | Change: on-line      |                        |

**P306 Final rounding-off 1**

(also refer to Section 10.1, Sheet 14, 10.3.31 and 10.3.32)

|                        |                      |                        |
|------------------------|----------------------|------------------------|
| Factory setting: 0.00s | Value range (steps): | 0.00 to 10.00s (0.01s) |
| Access: 20             | Change: on-line      |                        |

**Ramp-function generator, parameter set 2**

(also refer to the "mode of operation of the ramp-function generator" for P302)

Ramp-function generator parameter set 2 can be selected via the binary input function "ramp-function generator setting 2" (BEF31)

**P307 Ramp-up time 2**

(also refer to Section 10.1, Sheet 14 and 10.3.31)

|                        |                      |                         |             |
|------------------------|----------------------|-------------------------|-------------|
| Factory setting: 0.00s | Value range (steps): | 0.00 to 300.00s (0.01s) |             |
|                        |                      | 0.00 to 650.00s         | from SW2.00 |
| Access: 20             | Change: on-line      |                         |             |

**P308 Ramp-down time 2**

(also refer to Section 10.1, Sheet 14 and 10.3.31)

|                        |                      |                         |             |
|------------------------|----------------------|-------------------------|-------------|
| Factory setting: 0.00s | Value range (steps): | 0.00 to 300.00s (0.01s) |             |
|                        |                      | 0.00 to 650.00s         | from SW2.00 |
| Access: 20             | Change: on-line      |                         |             |

**P309 Initial rounding-off 2**

(also refer to Section 10.1, Sheet 14 and 10.3.31)

Factory setting: 0.00s

Value range (steps): 0.00 to 10.00s (0.01s)

Access: 20

Change: on-line

**P310 Final rounding-off 2**

(also refer to Section 10.1, Sheet 14 and 10.3.31)

Factory setting: 0.00s

Value range (steps): 0.00 to 10.00s (0.01s)

Access: 20

Change: on-line

**Ramp-function generator, parameter set 3**

(also refer to the "mode of operation of the ramp-function generator" for P302)

Ramp-function generator parameter set 3 can be selected via the binary input function "ramp-function generator setting 3" (BEF32)

**P311 Ramp-up time 3**

(also refer to Section 10.1, Sheet 14 and 10.3.32)

Factory setting: 0.00s

Value range (steps):

0.00 to 300.00s (0.01s)

0.00 to 650.00s

from SW2.00

Access: 20

Change: on-line

**P312 Ramp-down time 3**

(also refer to Section 10.1, Sheet 14 and 10.3.32)

Factory setting: 0.00s

Value range (steps):

0.00 to 300.00s (0.01s)

0.00 to 650.00s

from SW2.00

Access: 20

Change: on-line

**P313 Initial rounding-off 3**

(also refer to Section 10.1, Sheet 14 and 10.3.32)

Factory setting: 0.00s

Value range (steps): 0.00 to 10.00s (0.01s)

Access: 20

Change: on-line

**P314 Final rounding-off 3**

(also refer to Section 10.1, Sheet 14 and 10.3.32)

Factory setting: 0.00s

Value range (steps): 0.00 to 10.00s (0.01s)

Access: 20

Change: on-line





**P318 Speed limit, "minimum speed" (setpoint branch)**

(also refer to Section 10.1, Sheet 12)

The main setpoint is evaluated using two parameters (P317 and P318).  
 Parameter P317 defines the speed at the main setpoint = 100%,  
 Parameter P318 defines the speed at the main setpoint = 0%  
 (also refer to the following diagram).

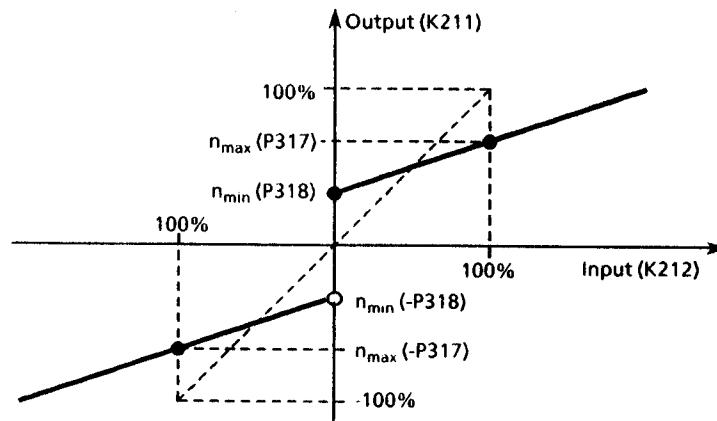

Factory setting: 0.00%

Value range (steps): 0.00 to 100.00% of the maximum speed (0.01%)

Access: 20

Change: on-line

**P319 Speed setpoint reduction, positive direction**

(also refer to Section 10.1, Sheet 13 and 10.3.24)

If the "setpoint reduction" command (BEF24 = 1) is input, the ramp-function generator input is limited in the positive direction to the value set at parameter P319, and in the negative direction to the value set at parameter P320.

Factory setting: 100.00%

Value range (steps): -100.0 to 100.00% of the maximum speed (0.01%)

Access: 20

Change: on-line

**P320 Speed setpoint reduction, negative direction**

(also refer to Section 10.1, Sheet 13 and 10.3.24)

If the "setpoint reduction" command (BEF24 = 1) is input, the ramp-function generator input is limited in the positive direction to the value set at parameter P319, and in the negative direction to the value set at parameter P320.

Factory setting: -100.00%

Value range (steps): -100.0 to 100.00% of the maximum speed (0.01%)

Access: 20

Change: on-line

## Settings for monitoring and limit values

### Monitoring settings

#### **P351 Threshold for the undervoltage trip**

(also refer to P086, Section 8.2.2.1 and 10.13)

If the supply voltage deviates by a significant amount, and does not re-enter the tolerance range within the "restart time", set at P086, error message F006 is initiated. The drive is kept in operating status o4 for the time that the deviation is excessive.

Factory setting: -20%

Value range (steps): 0 to -20% [armature: as a % of P071; field: as a % of 400V] (1%)  
[field: as a % of P078] from SW2.00

Access: 30

Change: on-line

#### **P352 Threshold for the overvoltage trip**

(also refer to P086, Section 8.2.2.1 and 10.13)

If the supply voltage deviates by a significant amount, and does not re-enter the tolerance range within the "restart time", set at P086, error message F007 is initiated. The drive is kept in operating status o4 for the time that the deviation is excessive.

Factory setting: 20%

Value range (steps): 0 to 20% [armature: as a % of P071; field: as a % of 400V] (1%)  
[field: as a % of P078] from SW2.00

Access: 30

Change: on-line

#### **P353 Response threshold for phase failure monitoring**

(also refer to P086, P089, Section 8.2.2.1 and 10.13)

If the supply voltage, in operating statuses  $\leq$  o4, falls below the set value, and is not evaluated as "good" within the "restart time", set at P086, fault message F004 or F005 is initiated

The drive is kept in operating status o4 or o5 for the time that the threshold value is not reached, and the subsequent voltage stabilizing time according to P090.

At switch-on a delay, set at P089, is inserted, in operating statuses o4 and o5, so that the voltages at all phases exceed the threshold set here before error message F004 or F005 is initiated

Factory setting: 40%

Value range (steps): 10 to 100% [armature = as a % of P071; field = as a % of 400V] (1%)  
[field: as a % of P078] from SW2.00

Access: 30

Change: on-line

#### **P354 Threshold for overspeed protection**

Fault message F038 is activated if the speed (K166) exceeds the set value by more than 0.50% (also refer to Sections 8.2.2.3 and 10.4.23).

Factory setting: 120.00%

Value range (steps): 0.00 to 120.00% of the maximum speed (0.01%)

Access: 20

Change: on-line

**P355 Stall protection time**

(also refer to Section 8.2.2.3)

F035 is activated, if the conditions for the "stall protection" fault message are available longer than the time set at parameter P355.

Factory setting: 0.5s

Value range (steps): 0.0 to 60.0s (0.1s)

Access: 20

Change: on-line

**P357 Threshold for tachometer interruption monitoring**

(also refer to Section 8.2.2.3)

F042 is suppressed, if the EMF actual value is less than the value set at parameter P357.

Factory setting: 10%

Value range (steps):

10 to 70% of the ideal average DC voltage at  $\alpha = 0$ ,  
i.e. % of P071 x 1.35 (1%)

Access: 20

Change: on-line

**P362 Threshold for speed controller monitoring**

(also refer to Section 8.2.2.3, description of fault message F031, and Section 10.4.22)

Factory setting: 2.00%

Value range (steps): 0.00 to 100.00% of the maximum speed (0.01%)

Access: 20

Change: on-line

**P363 Time for the dynamic control deviation of the speed controller**

(also refer to Section 8.2.2.3, description of fault message F031 and Section 10.4.22)

Factory setting: 0.10s

Value range (steps): 0.00 to 10.00s (0.01s)

Access: 20

Change: on-line

**P364 Threshold for the armature current controller monitoring**

(also refer to Section 8.2.2.3, description of fault message F032)

Factory setting: 2.00%

Value range (steps):

0.00 to 100.00% of the rated converter DC current (armature)  
according to P072 (0.01%)

Access: 20

Change: on-line

**P365 Time for the dynamic control deviation of the armature current controller**

(also refer to Section 8.2.2.3, description of fault message F032)

Factory setting: 0.10s

Value range (steps): 0.00 to 10.00s (0.01s)

Access: 20

Change: on-line

**P366 Threshold for the EMF controller monitoring**

(also refer to Section 8.2.2.3, description of fault message F033)

Factory setting: 2.00%

Value range (steps): 0.00 to 100.00% of the ideal average DC voltage at  $\alpha = 0$ , i.e. % of  $P071 * 1.35$  (0.01%)

Access: 20 Change: on-line

**P367 Time for the dynamic control deviation of the EMF controller**

(also refer to Section 8.2.2.3, description of fault message F033)

Factory setting: 0.10s Value range (steps): 0.00 to 10.00s (0.01s)

Access: 20 Change: on-line

**P368 Threshold for the field current controller monitoring**

(also refer to Section 8.2.2.3, description of fault message F034)

Factory setting: 2.00%

Value range (steps): 0.00 to 100.00% of the rated converter DC field current (0.01%)

Access: 20 Change: on-line

**P369 Time for the dynamic control deviation of the field current controller**

(also refer to Section 8.2.2.3, description of fault message F034)

Factory setting: 0.10s Value range (steps): 0.00 to 10.00s (0.01s)

Access: 20 Change: on-line

**Settings for the limit value monitor****P370 Speed threshold  $n_{\min}$** 

Speed threshold for the limit value monitor  $n < n_{\min}$  (also refer to BAF21 in Section 10.4.21).

Note:

This threshold also influences the control sequence at "shutdown" (refer to Section 10.3.90), "fast stop" (refer to Section 10.3.4) and when withdrawing the command "inching" or "crawl" (also refer to Sections 10.3.13 to 10.3.16) as well as the brake control (refer to Section 10.4.14).

Factory setting: 0.50%

Value range (steps): 0.00 to 120.00% of the maximum speed (0.01%)

Access: 20 Change: on-line

**P371 Hysteresis for the  $n < n_{\min}$  signal**

This value is added to the response threshold, if  $n < n_{\min}$  (also refer to BAF21 in Section 10.4.21)

Factory setting: 0.50%

Value range (steps): 0.00 to 100.00% of the maximum speed (0.01%)

Access: 20 Change: on-line

**P373 Speed threshold  $n_{x1}$  ( $n_{basic}$ )**

Speed threshold for limit value monitor  $n < n_{x1}$  (also refer to BAF16 in Section 10.4.16).

Factory setting: 0.50%

Value range (steps): 0.00 to 120.00% of the maximum speed (0.01%)

Access: 20                                      Change: on-line

**P374 Hysteresis for the  $n < n_{x1}$  signal ( $n < n_{basic}$  signal)**

This value is added to the response threshold, if  $n < n_{x1}$  (also refer to BAF16 in Section 10.4.16).

Factory setting: 0.50%

Value range (steps): 0.00 to 100.00% of the maximum speed (0.01%)

Access: 20                                      Change: on-line

**P376 Speed threshold  $n_{x2}$** 

Speed threshold limit value monitor  $n < n_{x2}$  (also refer to BAF17 in Section 10.4.17).

Factory setting: 0.50%

Value range (steps): 0.00 to 120.00% of the maximum speed (0.01%)

Access: 20                                      Change: on-line

**P377 Hysteresis for the  $n < n_{x2}$  signal**

This value is added to the response threshold, if  $n < n_{x2}$  (also refer to BAF17 in Section 10.4.17).

Factory setting: 0.50%

Value range (steps): 0.00 to 100.00% of the maximum speed (0.01%)

Access: 20                                      Change: on-line

**P379 Speed threshold  $n_{x3}$** 

Speed threshold limit value monitor  $n < n_{x3}$  (also refer to BAF18 in Section 10.4.18).

Factory setting: 0.50%

Value range (steps): 0.00 to 120.00% of the maximum speed (0.01%)

Access: 20                                      Change: on-line

**P380 Hysteresis for the  $n < n_{x3}$  signal**

This value is added to the response threshold, if  $n < n_{x3}$  (also refer to BAF18 in Section 10.4.18).

Factory setting: 0.50%

Value range (steps): 0.00 to 100.00% of the maximum speed (0.01%)

Access: 20                                      Change: on-line



**P394 Field current threshold  $I_f < I_{f_{min}}$** 

Threshold for the limit value monitor  $I_f < I_{f_{min}}$  (also refer to BAF28 in Section 10.4.28).

Factory setting: 5.00%

Value range (steps): 0.00 to 199.99% of the rated converter DC field current (0.01%)

Access: 20 Change: on-line

**P395 Hysteresis for the  $I_f < I_{f_{min}}$  signal**

This value is added to the response threshold, if  $I_f < I_{f_{min}}$  (also refer to BAF28 in Section 10.4.28).

Factory setting: 1.00%

Value range (steps): 0.00 to 100.00% of the rated converter DC field current (0.01%)

Access: 20 Change: on-line

**P396 Hysteresis for the direction of rotation signal (counter-clockwise)**

from SW2.00

The direction of rotation signal (binary output function BAF13) switches to "counter clockwise" (= high), if  $n_{act}$  (K167) < -P396. It switches to "clockwise" (= low), if  $n_{act}$  (K167) > P396 (also refer to Section 10.4.13).

Factory setting: 0.01% Value range (steps): 0.00 to 10.00% of the maximum speed

Access: 20 Change: on-line

**Settings for the basic converter technology functions****Settings for the "digital setpoint (e.g. inching)" function****P401 Digital setpoint 1**

(also refer to Section 10.1, Sheet 12 and 10.3.13 to 23)

The setpoint, set at the parameter, is switched-in, if the select function "setpoint input" (BEF17 to BEF23), "inching" (BEF13, BEF14) or "crawl" (BEF15, BEF16) are requested at binary select input 1 (terminal 39).

Factory setting: 0.0% Value range (steps): -199.9 to 199.9% (0.1%)  
0.00% -199.9 to 199.99% (0.01%) from SW2.00

Access: 20 Change: on-line

**P402 Digital setpoint 2**

(also refer to Section 10.1, Sheet 12 and 10.3.13 to 23)

The setpoint, set at the parameter, is switched-in, if the select function "setpoint input" (BEF17 to BEF23), "inching" (BEF13, BEF14) or "crawl" (BEF15, BEF16) are requested at binary select input 2 (terminal 40).

Factory setting: 0.0% Value range (steps): -199.9 to 199.9% (0.1%)  
0.00% -199.9 to 199.99% (0.01%) from SW2.00

Access: 20 Change: on-line



**P403 Digital setpoint 3**

(also refer to Section 10.1, Sheet 12 and 10.3.13 to 23)

The setpoint, set at the parameter, is switched-in, if the select function "setpoint input" (BEF17 to BEF23), "inching" (BEF13, BEF14) or "crawl" (BEF15, BEF16) are requested at binary select input 3 (terminal 41)

Factory setting: 0.0% Value range (steps): -199.9 to 199.9% (0.1%)  
0.00% -199.9 to 199.99% (0.01%) from SW2.00

Access: 20 Change on-line

**P404 Digital setpoint 4**

(also refer to Section 10.1, Sheet 12 and 10.3.13 to 23)

The setpoint, set at the parameter, is switched-in, if the select function "setpoint input" (BEF17 to BEF23), "inching" (BEF13, BEF14) or "crawl" (BEF15, BEF16) are requested at binary select input 4 (terminal 42).

Factory setting: 0.0% Value range (steps): -199.9 to 199.9% (0.1%)  
0.00% -199.9 to 199.99% (0.01%) from SW2.00

Access: 20 Change: on-line

**P405 Digital setpoint 5**

(also refer to Section 10.1, Sheet 12 and 10.3.13 to 23)

The setpoint, set at the parameter, is switched-in, if the select function "setpoint input" (BEF17 to BEF23), "inching" (BEF13, BEF14) or "crawl" (BEF15, BEF16) are requested at binary select input 5 (terminal 43).

Factory setting: 0.0% Value range (steps): -199.9 to 199.9% (0.1%)  
0.00% -199.9 to 199.99% (0.01%) from SW2 00

Access: 20 Change: on-line

**P406 Digital setpoint 6**

(also refer to Section 10.1, Sheet 12 and 10.3.13 to 23)

The setpoint, set at the parameter, is switched-in, if the select function "setpoint input" (BEF17 to BEF23), "inching" (BEF13, BEF14) or "crawl" (BEF15, BEF16) are requested at binary select input 6 (terminal 36).

Factory setting: 0.0% Value range (steps): -199.9 to 199.9% (0.1%)  
0.00% -199.9 to 199.99% (0.01%) from SW2.00

Access: 20 Change: on-line

**P409 Setpoint for "inching" from the control word from SW1.10**

(also refer to Section 10.1, Sheet 12 and 10.3.13)

The setpoint, set at the parameter, is switched-in, when the "inching" command (BEF13), is entered using a bit in the freely-definable control word STWF

Factory setting: 0.0% Value range (steps): -199.9 to 199.9% (0.1%)  
0.00% -199.9 to 199.99% (0.01%) from SW2.00

Access: 20 Change: on-line

**P410 Setpoint for "inching and bypass ramp-function generator" from the control word** (also refer to Section 10.1, Sheet 12 and 10.3.14) **from SW1.10**

The setpoint, set at the parameter, is switched-in, if the command "inching and bypass ramp-function generator" (BEF14) is entered via a bit in the STWF.

Factory setting: 0.0% Value range (steps): -199.9 to 199.9% (0.1%)  
0.00% -199.9 to 199.99% (0.01%) from SW2.00

Access: 20 Change: on-line

**P411 Setpoint for "crawl" from the control word** **from SW1.10**

(also refer to Section 10.1, Sheet 12 and 10.3.15)

The setpoint, set at the parameter, is switched-in, if the command "crawl" (BEF15) is entered via a bit in the STWF.

Factory setting: 0.0% Value range (steps): -199.9 to 199.9% (0.1%)  
0.00% -199.9 to 199.99% (0.01%) from SW2.00

Access: 20 Change: on-line

**P412 Setpoint for "crawl and bypass ramp-function generator" from the control word** (also refer to Section 10.1, Sheet 12 and 10.3.16) **from SW1.10**

The setpoint, set at the parameter, is switched-in, if the command "crawl and bypass ramp-function generator" (BEF16) is entered via a bit in the STWF.

Factory setting: 0.0% Value range (steps): -199.9 to 199.9% (0.1%)  
0.00% -199.9 to 199.99% (0.01%) from SW2.00

Access: 20 Change: on-line

**P413 Setpoint for "fixed setpoint" from the control word** **from SW1.10**

(also refer to Section 10.1, Sheet 12 and 10.3.17)

The setpoint, set at the parameter, is switched-in if the command "fixed setpoint" (BEF17) is entered using a bit in the STWF

Factory setting: 0.0% Value range (steps): -199.9 to 199.9% (0.1%)  
0.00% -199.9 to 199.99% (0.01%) from SW2.00

Access: 20 Change: on-line

**P414 Setpoint for "fixed setpoint and bypass ramp-function generator" from the control word** (also refer to Section 10.1, Sheet 12 and 10.3.18) **from SW1.10**

The setpoint, set at the parameter, is switched-in if the command "fixed setpoint and bypass ramp-function generator" (BEF18) is entered using a bit in the STWF.

Factory setting: 0.0% Value range (steps): -199.9 to 199.9% (0.1%)  
0.00% -199.9 to 199.99% (0.01%) from SW2.00

Access: 20 Change: on-line

**P415 Setpoint for "supplementary setpoint before the technology controller" from the control word** (also refer to Section 10.1, Sheet 10 and 10.3.19) **from SW1.10**

The setpoint, set at the parameter, is switched-in if the command "supplementary setpoint before the technology controller" (BEF19) is entered using a bit in the STWF

Factory setting: 0.0% Value range (steps): -199.9 to 199.9% (0.1%)  
0.00% -199.9 to 199.99% (0.01%) from SW2.00

Access: 20 Change: on-line

**P416 Setpoint for "supplementary setpoint before the ramp-function generator" from the control word** (also refer to Section 10.1, Sheet 12 and 10.3.20) **from SW1.10**

The setpoint, set at the parameter, is switched-in if the command "supplementary setpoint before the ramp-function generator" (BEF20) is entered via a bit in the STWF.

Factory setting: 0.0% Value range (steps): -199.9 to 199.9% (0.1%)  
0.00% -199.9 to 199.99% (0.01%) from SW2.00

Access 20 Change: on-line

**P417 Setpoint for "supplementary setpoint before the speed controller" from the control word** (also refer to Section 10.1, Sheet 14 and 10.3.21) **from SW1.10**

The setpoint, set at the parameter, is switched-in if the command "supplementary setpoint before the speed controller" (BEF21) is entered via a bit in the STWF.

Factory setting: 0.0% Value range (steps): -199.9 to 199.9% (0.1%)  
0.00% -199.9 to 199.99% (0.01%) from SW2.00

Access 20 Change: on-line

**P418 Setpoint for "supplementary setpoint before torque limiting" from the control word** (also refer to Section 10.1, Sheet 15 and 10.3.22) **from SW1.10**

The setpoint, set at the parameter, is switched-in if the command "supplementary setpoint before torque limiting" (BEF22) is entered via a bit in the STWF.

Factory setting: 0.0% Value range (steps): -199.9 to 199.9% (0.1%)  
0.00% -199.9 to 199.99% (0.01%) from SW2.00

Access: 20 Change: on-line

**P419 Setpoint for "supplementary setpoint before the current controller" from the control word** (also refer to Section 10.1, Sheet 17 and 10.3.23) **from SW1.10**

The setpoint, set at the parameter, is switched-in if the command "supplementary setpoint before the current controller" (BEF23) is entered via a bit in the STWF

Factory setting: 0.0% Value range (steps): -199.9 to 199.9% (0.1%)  
0.00% -199.9 to 199.99% (0.01%) from SW2.00

Access: 20 Change: on-line

**Settings for the "technology controller" function****P420 Filter time, technology controller actual value from SW1.10**

(also refer to Section 10.1, Sheet 10)

Factory setting: 0ms Value range (steps): 0 to 10000ms (1ms)

Access: 20 Change: on-line

**P421 Derivative action time, technology controller actual value from SW1.10**

(also refer to Section 10.1, Sheet 10)

Factory setting: 0ms Value range (steps): 0 to 1000ms (1ms)

Access: 20 Change: on-line

**P422 Filter time for the technology controller setpoint filtering from SW2.00**

(also refer to Section 10.1, Sheet 10)

Factory setting: 0ms Value range (steps): 0 to 10000ms (1ms)

Access: 20 Change: on-line

**P424 Control word, technology controller from SW1.10**

(also refer to Section 10.1, Sheet 10)

xxx0 Set controller I component to zero (i.e. pure P controller)

xxx1 Controller I component active

xx0x Set controller P component to zero (i.e. pure I controller)

xx1x Controller P component active

x0xx The setpoint is switched-in with the correct polarity

x1xx The setpoint is switched-in, inverted

0xxx The actual value is switched-in with the correct polarity

1xxx The actual value is switched-in, inverted

Factory setting: 0011 Value range (steps): 0000 to 1111 (1 hex)

Access: 20 Change: off-line

**P425 Technology controller, P gain from SW1.10**

(also refer to Section 10.1, Sheet 10)

Factory setting: 3.00 Value range (steps): 0.10 to 200.00 (0.01)

Access: 20 Change: on-line

**P426 Technology controller, integral action time from SW1.10**

(also refer to Section 10.1, Sheet 10)

Factory setting: 0.650s Value range (steps): 0.010 to 10.000s (0.001s)

Access: 20 Change: on-line

**P427 Technology controller, droop from SW1.10**

(also refer to Section 10.1, Sheet 10 and 10.3.36)

Feedback, which can be parameterized, is connected in parallel with the I- and P-components of the technology controller (accesses the summing point of the setpoint and actual value). If the binary input function "enable technology controller droop" (BEF36) was assigned a terminal or a bit of the freely-definable control word STWF, this feedback can be enabled and disabled via this input. If an input has not been parameterized as "enable technology controller droop", the feedback is always effective (disabled using parameter value = 0)  
10% droop means that for 100% controller output, the actual value deviates by 10% from the setpoint

Factory setting: 0.0% Value range (steps): 0.0 to 60.0% controller output (0.1%)

Access: 20 Change: on-line

**P428 Evaluation factor for the technology controller output from SW1.10**

(also refer to Section 10.1, Sheet 10)

Factory setting: 100.0% Value range (steps): -100.0 to 100.0% (0.1%)

Access: 20 Change: on-line

**P430 Positive limit for the technology controller output from SW2.00**

(also refer to Section 10.1, Sheet 10)

Factory setting: 100.0% Value range (steps): 0.0 to 199.9% (0.1%)

Access: 20 Change: on-line

**P431 Negative limit for the technology controller output from SW2.00**

(also refer to Section 10.1, Sheet 10)

Factory setting: -100.0% Value range (steps): -199.9 to 0.0% (0.1%)

Access: 20 Change: on-line

**P432 Positive limit for the technology controller droop from SW2.00**

(also refer to Section 10.1, Sheet 10)

Factory setting: 100.00% Value range (steps): 0.00 to 199.99% (0.01%)

Access: 20 Change: on-line

**P433 Negative limit for the technology controller droop from SW2.00**

(also refer to Section 10.1, Sheet 10)

Factory setting: -100.0% Value range (steps): -199.9 to 0.00% (0.01%)

Access: 20 Change: on-line

**P450 Maximum speed at the gearbox outdrive (rough) from SW2.00**

(also refer to P684 and Section 10.1, Sheet 7)

Rough setting of the drive-out shaft speed of a mechanical gearbox. The value of parameter P451 is added to this value.

Factory setting: 500 RPM Value range (steps): 1 to 10000 RPM

Access: 20 Change: on-line

**P451 Maximum speed at the gearbox outdrive (fine) from SW2.00**

(also refer to P684 and Section 10.1, Sheet 7)

Fine setting of the drive-out shaft speed of a mechanical gearbox. The value of parameter P450 is added to this value.

Factory setting: 0.00 RPM Value range (steps): 0.00 to 0.99 RPM

Access: 20 Change: on-line

**P452 Maximum speed for pulse encoder operation (fine) from SW2.00**

When using the speed actual value from the pulse encoder (P083 = 2), the maximum speed is defined using parameters P143 and P452. The speed actual value from the pulse encoder is normalized using parameters P143 and P452, i.e, the speed, set using these parameters, corresponds to a speed actual value (K011, K012) of 100 %. The values of parameters P143 and P452 are added.

Factory setting: 0.00 RPM Value range (steps): 0.00 to 0.99 RPM

Access: 20 Change: on-line

**Settings for the "motorized potentiometer" function****P460 Selecting the motorized potentiometer operating mode from SW1.10**

(also refer to Section 10.1, Sheet 11, 10.3.28 to 10.3.30)

xxx1 Motorized potentiometer operation

xxx2 Ramp-function generator operation

xx0x The motorized potentiometer setpoint is set to zero for operating statuses &gt; 05

xx1x The motorized potentiometer setpoint remains stored in all operating statuses (even when the electronics voltage is disconnected)

x0xx The motorized potentiometer - ramp-function generator is bypassed in the automatic mode (P462 and P463 ineffective)

x1xx Motorized potentiometer - ramp-function generator is effective in the manual and automatic mode

0xxx Setting range of the motorized potentiometer via the RAISE/LOWER button: 0 to 100%

Clockwise/counter-clockwise changeover via binary input function 28 or 29, 30

from SW2.00

1xxx Setting range of the motorized potentiometer via the RAISE/LOWER button: -100% to 100%

Clockwise/counter-clockwise changeover via binary input function 28 or 29, 30 is

ineffective

from SW2.00

Factory setting: 0101 Value range (steps): 0001 to 1112 (1 hex)

Access: 20 Change: off-line

**P461 Selecting the motorized potentiometer setpoint from SW1.10**

(also refer to Section 10.1, Sheet 11)

Number of the "connector" whose value should be connected to the ramp-function generator.

- 0 Fixed value 0% (= connector K000)
- 1 Fixed value 100% (= connector K001)
- 2 0%
- 3 Connector K003
- to
- 299 Connector K299

Factory setting: 2 Value range: 0 to 399 (connector number)

Access: 20 Change: off-line

**P462 Motorized potentiometer ramp-up time from SW1.10**

(also refer to Section 10.1, Sheet 11)

Factory setting: 10.00s Value range (steps): 0.00 to 300.00s (0.01s)

Access: 20 Change: on-line

**P463 Motorized potentiometer ramp-down time from SW1.10**

(also refer to Section 10.1, Sheet 11)

Factory setting: 10.00s Value range (steps): 0.00 to 300.00s (0.01s)

Access: 20 Change: on-line

**P464 Motorized potentiometer evaluation factor from SW1.10**

(also refer to Section 10.1, Sheet 11)

Factory setting: 100% Value range (steps): -100 to 100% (1%)

Access: 20 Change: on-line

**P465 Zoom factor for the motorized potentiometer from SW2.00**

(also refer to Section 10.1, Sheet 11)

0 Parameters P462 and P463 are multiplied by a factor of 11 Parameters P462 and P463 are multiplied by a factor of 60

Factory setting: 0 Value range: 0 to 1

Access: 20 Change: on-line

**P466 Selecting the motorized potentiometer setting value from SW2.00**

(also refer to Section 10.1, Sheet 11 and 10.3.68)

Number of the connector, which serves as motorized potentiometer setting value, when the binary input function "set motorized potentiometer" (BEF68 = 1) is activated.

- 2 The motorized potentiometer is set to 0

Factory setting: 2 Value range: 0 to 399 (connector number)

Access: 20 Change: off-line

**Settings for the "tension and ratio control" function****P470 Selecting the operating mode for the tension/ratio control from SW1.10**

(also refer to Section 10.1, Sheet 13)

- 0 Tension/ratio control switched-out
- 1 Tension control
- 2 Ratio control
- etc

Factory setting: 0 Value range: 0 to 399 (connector number)

Access: 20 Change: off-line

**P471 Selecting the tension/ratio factor from SW1.10**

(also refer to Section 10.1, Sheet 13)

Number of the connector from which the tension/ratio factor is received.

Factory setting: 0 Value range: 0 to 399 (connector number)

Access: 20 Change: off-line

**Settings for the "oscillation" and "forcing" functions****P480 Oscillation setpoint 1 from SW2.00**

(also refer to Section 10.1, Sheet 12 and 10.3.12)

Parameters P480 to P483 define the signal shape of a square-wave signal (oscillation setpoint). The value, set at P480 defines the signal level during time, according to P481; and the value, set at P482, defines the signal level, during the time, according to P483.

The square-wave signal is switched-in when activating the binary input function "enable wobulation (oscillation)" (BEF12).

The square-wave signal can be set to 0, or started in synchronism and switched-in as setpoint, by selecting the "forcing" function via P051 = 24 and depressing the appropriate operator control panel keys.

Factory setting: 0.5% Value range (steps): -199.9 to 199.9% of the maximum speed (0.1%)

Access: 20 Change: on-line

**P481 Oscillation time 1 from SW2.00**

(also refer to P480, Section 10.1, Sheet 12, 10.3.12 and 10.12)

Factory setting: 0.1s Value range (steps): 0.1 to 300.0s (0.1s)

Access: 20 Change: on-line



**P482 Oscillation setpoint 2** **from SW2.00**

(also refer to P480, Section 10.1, Sheet 12, 10.3.12 and 10.12)

The setpoint, set at the parameter, is switched-in, for the time set at P481, if the select function "Wobulation enable" (BEF12) is requested at one of the binary select inputs.

Factory setting: -0.4%      Value range (steps):      -199.9 to 199.9% of the maximum speed (0.1%)

Access: 20      Change: on-line

**P483 Oscillation time 2** **from SW2.00**

(also refer to P480, Section 10.1, Sheet 12, 10.3.12 and 10.12)

Factory setting: 0.1s      Value range (steps): 0.1 to 300.0s (0.1s)

Access: 20      Change: on-line

**Settings for the "master/slave drive" function****P500 Selecting the setpoint source for the slave drive**

(also refer to Section 10.1, Sheet 15 and 10.41)

Number of the connector which issues the current setpoint in the "slave drive" mode.

Factory setting: 2      Value range: 0 to 399 (connector number)

Access: 20      Change: off-line

**Settings for the "friction compensation" function**

**P520 Friction at 0% speed** **from SW1.10**

**P521 Friction at 10% speed** **from SW1.10**

to

**P529 Friction at 90% speed** **from SW1.10**

**P530 Friction at 100% speed and higher** **from SW1.10**

(also refer to Section 10.1, Sheet 16)

Parameters P520 to P530 are the armature current or torque setpoints required for a steady-state speed of 0%, 10% to 100% of the maximum speed (in 10% speed steps).

These parameters are points along the friction characteristic. They are, according to P170 (x0 or x1) an armature current or torque setpoint, and are automatically set during the optimization run for the friction- and moment of inertia compensation (P051 = 28). P520 is set to 0.0%

The characteristic is interpolated between the points, dependent on the speed controller actual value (K165), whereby the output of the friction compensation, has the same sign as the speed controller actual value.

P530 is specified by the friction compensation, also for a speed controller actual value > 100% of the maximum speed.

For operation in both directions of rotation, it is recommended that P520 is kept at 0.05, in order to prevent armature current oscillation at 0% speed.

Factory setting: 0.0%      Value range (steps): 0.0 to 100.0% rated converter DC current or rated converter torque (0.1%)

Access: 20      Change: on-line

### Settings for the moment of inertia compensation" function

#### **P540    Accelerating time      from SW1.10**

(also refer to Section 10.1, Sheet 16)

The accelerating time is that time, which would be necessary to accelerate the drive from 0% to 100% of the maximum speed (friction neglected), at 100% rated converter current (armature) and 100% rated motor field current. It is a measure of the drive moment of inertia.

This parameter is automatically set during the optimization run for the friction- and moment of inertia compensation (P051 = 28).

Factory setting: 0.00s      Value range (steps): 0.00 to 650.00s (0.01s)

Access: 20      Change: on-line

#### **P541    Acceleration P gain      from SW1.10**

(also refer to Section 10.1, Sheet 16)

Proportional gain for the function "acceleration dependent on the setpoint-actual value difference" or "freely-connectable acceleration" (also refer to parameters P543 to P545).

Factory setting: 0.00      Value range (steps): 0.00 to 650.00 (0.01)

Access: 20      Change: on-line

#### **P543    Threshold for acceleration dependent on the setpoint-actual value difference**

(also refer to Section 10.1, Sheet 16)

**from SW1.10**

With acceleration dependent on the setpoint-actual value difference function, only that component of the speed controller setpoint-actual value difference is connected-through, whose absolute value exceeds the threshold set using this parameters (also refer to parameters P541 and P545).

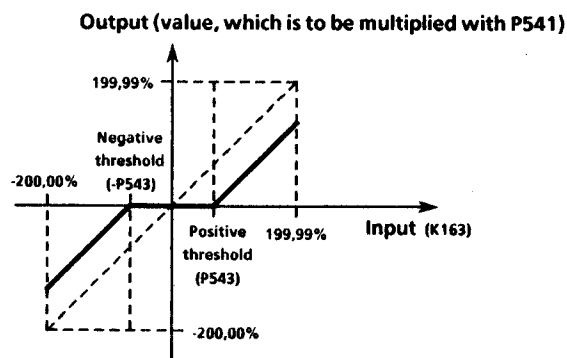

Factory setting: 0.00%      Value range (steps): 0.00 to 100.00% of the maximum speed (0.01%)

Access: 20      Change: on-line

## P544 Selecting the freely-connectable acceleration from SW1.10

(also refer to Section 10.1, Sheet 16)

Number of the connector, which should be effective as input for the freely-connectable acceleration (also refer to parameters P541 and P545).

Factory setting: 2

Value range: 0 to 399 (connector number)

Access: 20

Change: on-line

## P545 Selecting the acceleration from SW1.10

(also refer to Section 10.1, Sheet 16)

Selecting the source for inertia compensation:

- 1 A torque setpoint is calculated for the inertia torque compensation from the rate of rise of the speed controller setpoint (K168) and the accelerating time (refer to parameter P540).

$$\text{K150 as a \% of the rated converter torque} = \frac{d(\text{K168 in \% } n_{\max})}{dt} * \text{P540}$$

Note:

Relatively high jumps can be obtained for K150 due to the internal computation format, as, for standard ramp-up times, the speed controller setpoint rate of rise is low.

- 2 A torque setpoint is calculated for the moment of inertia compensation from the rate of rise of the ramp-function generator (rate of rise of the ramp-function generator output) and the accelerating time (refer to parameter P540).

$$\text{K151 as a \% of the rated converter torque} = \frac{\text{K191 in \% } n_{\max}}{\text{Supply period duration}} * \text{P540}$$

6

Note:

K191 has very low values for the standard ramp-up times, and can fluctuate significantly when the ramp-function generator has finished integrating, if the ramp-function generator setpoint is not kept precisely constant. However, K151 is calculated with a high resolution.

Note:

Ramp-up and ramp-down times of the ramp-function generator must be selected high enough, so that the drive actual speed can follow the actual ramp-function generator output, without the armature current limits being reached. Further, appropriate initial- and end rounding-off times should be parameterized, to keep the torque setpoint smooth (and therefore the armature current), once the ramp-function generator has stopped integrating, in spite of a gently fluctuating speed setpoint.

- 3 Inertia compensation dependent on the speed controller setpoint-actual value difference

That component of the speed controller setpoint-actual value difference (K163), whose absolute value exceeds the threshold, set using parameter P543, after multiplication with P541 (acceleration P gain) provides the torque setpoint which should be connected-through (also refer to the diagram under P543).

$$\text{K152 as a \% of the rated converter torque} = \pm (|\text{K163}| \text{ in \% } n_{\max} - \text{P543}) * \text{P541}$$

for  $|\text{K163}| > \text{P543}$

$$\text{K152 as a \% of the rated converter torque} = 0 \quad \text{for } |\text{K163}| \leq \text{P543}$$

- 4 The input of the freely-connectable acceleration, selected using parameter P544, when multiplied with P 541 (P gain of the acceleration) provides the torque setpoint which should be connected through.

$K153 \text{ in } \% = \text{connector according to P544 as } \% * P541$

Factory setting: 2                      Value range: 1 to 4  
 Access: 20                              Change: off-line

**P546 Filter time for the moment of inertia compensation** **from SW2.00**

(also refer to Section 10.1, Sheet 16)

Factory setting: 0ms                      Value range (steps): 0 to 10000ms (1ms)  
 Access: 20                                  Change: on-line

**Settings for the "speed controller adaption" function**

**P550 Speed controller, P gain (adaption)**

(also refer to Section 10.1, Sheet 15)

Proportional gain of the speed controller

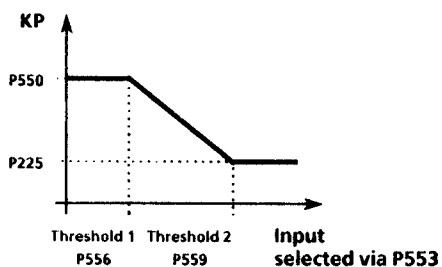

Factory setting: 3.00                      Value range (steps): 0.10 to 200.00 (0.01)  
 Access: 20                                  Change: on-line

**P551 Speed controller, integral-action time (adaption)**

(also refer to Section 10.1, Sheet 15)

Integral-action time of the speed controller

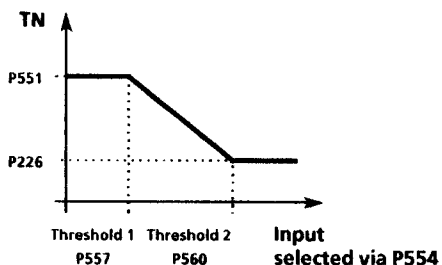

Factory setting: 0.650s                      Value range (steps): 0.010 to 10.000s (0.001s)  
 Access: 20                                  Change: on-line

**P552 Speed controller, droop (adaption)**

(also refer to Section 10.1, Sheet 15)

Speed controller droop factor (also refer to P227, speed controller droop)

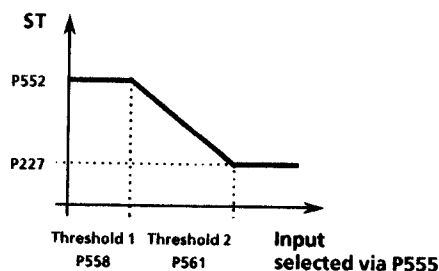

Factory setting: 0.0%

Value range (steps): 0.0 to 10.0% rated converter torque (0.1%)

Access: 20

Change: on-line

**P553 Influencing quantity for adapting the speed controller P gain**

(also refer to P550 and Section 10.1, Sheet 15)

- 0 Fixed value 0% (= connector K000)
- 1 Fixed value 100% (= connector K001)
- 2 Fixed value 0%
- 3 Connector K003
- etc.

If the connector value  $\geq$  P559, the value of P225 is used as  $K_p$ .

Factory setting: 2

Value range: 0 to 399 (connector number)

Access: 20

Change: off-line

**P554 Influencing quantity for adapting the speed controller integral-action time**

(also refer to P551 and Section 10.1, Sheet 15)

- 0 Fixed value 0% (= connector K000)
- 1 Fixed value 100% (= connector K001)
- 2 Fixed value 0%
- 3 Connector K003
- etc.

If the connector value  $\geq$  P560, then the value of P226 is used as  $T_n$ .

Factory setting: 2

Value range: 0 to 399 (connector number)

Access: 20

Change: off-line

**P555 Influencing quantity for adapting the speed controller droop**

(also refer to P552 and Section 10.1, Sheet 15)

- 0 Fixed value 0% (= connector K000)
  - 1 Fixed value 100% (= connector K001)
  - 2 Fixed value 0%
  - 3 Connector K003
- etc.

If connector value  $\geq$  P561, then the value of P227 is used as droop.

Factory setting: 2                      Value range: 0 to 399 (connector number)

Access: 20                              Change: off-line

**P556 Threshold 1 for adapting the speed controller P gain**

(also refer to P550 and Section 10.1, Sheet 15)

Factory setting: 0.00%              Value range (steps): 0.00 to 100.00% (0.01%)

Access: 20                              Change: on-line

**P557 Threshold 1 for adapting the speed controller integral-action time**

(also refer to P551 and Section 10.1, Sheet 15)

Factory setting: 0.00%              Value range (steps): 0.00 to 100.00% (0.01%)

Access: 20                              Change: on-line

**P558 Threshold 1 for adapting the speed controller droop**

(also refer to P552 and Section 10.1, Sheet 15)

Factory setting: 0.00%              Value range (steps): 0.00 to 100.00% (0.01%)

Access: 20                              Change: on-line

**P559 Threshold 2 for adapting the speed controller P gain**

(also refer to P550 and Section 10.1, Sheet 15)

Factory setting: 0.00%              Value range (steps): 0.00 to 100.00% (0.01%)

Access: 20                              Change: on-line

**P560 Threshold 2 for adapting the speed controller integral-action time**

(also refer to P551 and Section 10.1, Sheet 15)

Factory setting: 0.00%              Value range (steps): 0.00 to 100.00% (0.01%)

Access: 20                              Change: on-line

**P561 Threshold 2 for adapting the speed controller droop**

(also refer to P552 and Section 10.1, Sheet 15)

Factory setting: 0.00%              Value range (steps): 0.00 to 100.00% (0.01%)

Access: 20                              Change: on-line

## Structuring the control

### Settings for structuring the torque shell

#### **P600** Selecting the gating unit input (armature)

(also refer to Section 10.1, Sheet 18)

Number of the connector which is fed to the gating unit input

- 0 Fixed value 0% (= connector K000)
- 1 Connector K001
- 2 Output of the armature current controller and armature current pre-control
- 3 Connector K003
- etc.

Factory setting: 2                      Value range: 0 to 399 (connector number)

Access: 30                              Change: off-line

#### **P601.ii** Selecting the armature current controller setpoint (before current limiting)

(also refer to Section 10.1, Sheet 17)

Number of the connector, which is fed to the armature current controller setpoint.

Factory setting: 2 (output of the torque limiting)

Value range: 0 to 399 (connector number)

Access: 30                              Change: off-line                      Index ii = 00 to 03

#### **P602** Selecting the armature current controller actual value

(also refer to Section 10.1, Sheet 18)

Number of the connector which is fed to the armature current controller actual value.

Factory setting: 2 (internal armature current actual value)

Value range: 0 to 399 (connector number)

Access: 30                              Change: off-line

#### **P603.ii** Selecting the variable current limit in torque direction I

(also refer to Section 10.1, Sheet 17)

Number of the connector, which is fed to the variable current limit in torque direction I.

Factory setting: 2 (no variable current limit effective)

Value range: 0 to 399 (connector number)

Access: 30                              Change: off-line                      Index ii = 00 to 03

**P604.ii Selecting the variable current limit in torque direction II**

(also refer to Section 10.1, Sheet 17)

Number of the connector, which is fed to the variable current limit in torque direction II.

Factory setting: 2 (it has the same effect as the signal from P603.ii, with the opposite sign)

Value range: 0 to 399 (connector number)

Access: 30

Change: off-line

Index ii = 00 to 03

**P605.ii Selecting the variable positive torque limit**

(also refer to Section 10.1, Sheet 17)

Number of the connector which is fed to the positive torque limit.

Factory setting: 2 (variable torque limit not effective)

Value range: 0 to 399 (connector number)

Access: 30

Change: off-line

Index ii = 00 to 03

**P606.ii Selecting the variable negative torque limit**

(also refer to Section 10.1, Sheet 17)

Number of the connector which is fed to the negative torque limit.

Factory setting: 2 (it has the same effect as the signal from P605.ii with the opposite sign)

Value range: 0 to 399 (connector number)

Access: 30

Change: off-line

Index ii = 00 to 03

**P607.ii Selecting the torque setpoint**

(also refer to Section 10.1, Sheet 15)

Number of the connector which is fed to the torque setpoint.

Factory setting: 2 (speed controller output)

Value range: 0 to 399 (connector number)

Access: 30

Change: off-line

Index ii = 00 to 03

**Settings for structuring the speed controller****P608.ii Selecting the speed controller setpoint**

(also refer to Section 10.1, Sheet 15)

Number of the connector which is fed to the speed controller setpoint

Factory setting: 2 (setpoint limiting output)

Value range: 0 to 399 (connector number)

Access: 30

Change: off-line

Index ii = 00 to 03



**P609 Selecting the speed controller actual value**

(also refer to Section 10.1, Sheet 15)

Number of the connector, which is switched to the speed controller actual value

Factory setting: 2 (actual value from terminals XT-101 to XT-104, main actual value)

Value range: 0 to 399 (connector number)

Access: 30

Change: off-line

**Settings for structuring the field and EMF control****P610 Selecting the gating unit input (field)**

(also refer to Section 10.1, Sheet 20)

Number of the connector which is fed to the gating unit input (field).

Factory setting: 2 (output, field current controller and field current pre-control)

Value range: 0 to 399 (connector number)

Access: 30

Change: off-line

**P611.ii Selecting the field current controller- setpoint input**

(also refer to Section 10.1, Sheet 19)

Number of the connector which is fed to the field current controller setpoint input.

Factory setting: 2 (EMF controller output)

Value range: 0 to 399 (connector number)

Access: 30

Change: off-line

Index ii = 00 to 03

**P612 Selecting the field current controller actual value input**

(also refer to Section 10.1, Sheet 20)

Number of the connector which is fed to the field current controller actual value input

Factory setting: 2 (internal field current actual value)

Value range: 0 to 399 (connector number)

Access: 30

Change: off-line

**P613.ii Selecting the variable field current setpoint upper limit**

(also refer to Section 10.1, Sheet 19)

Number of the connector which is fed to the variable field current setpoint upper limit.

Factory setting: 2 (variable field current limit not effective)

Value range: 0 to 399 (connector number)

Access: 30

Change: off-line

Index ii = 00 to 03

**P614.ii Selecting the variable field current setpoint lower limit**

(also refer to Section 10.1, Sheet 19)

Number of the connector which is fed to the variable field current setpoint lower limit.

Factory setting: 2 (variable field current limit not effective)

Value range: 0 to 399 (connector number)

Access: 30

Change: off-line

Index ii = 00 to 03

**P615.ii Selecting the EMF controller setpoint**

(also refer to Section 10.1, Sheet 19)

Number of the connector, which is fed to the EMF controller setpoint input.

Factory setting: 2 (internal EMF setpoint)

Value range: 0 to 399 (connector number)

Access: 30

Change: off-line

Index ii = 00 to 03

**P616 Selecting the EMF controller actual value**

(also refer to Section 10.1, Sheet 19)

Number of the connector which is fed to the EMF controller actual value input.

Factory setting: 2 (internal EMF actual value)

Value range: 0 to 399 (connector number)

Access: 30

Change: off-line

**Settings for structuring the ramp-function generator****P620.ii Selecting the variable positive limit for the ramp-function generator output**

(also refer to Section 10.1, Sheet 14)

Number of the connector which is fed to the variable positive limit for the ramp-function generator output.

Note:

If the selected connector has a negative value, this results in a negative minimum speed setpoint being entered.

Factory setting: 2 (fixed limiting to 200%)

Value range: 0 to 399 (connector number)

Access: 30

Change: off-line

Index ii = 00 to 03

**P621.ii Selecting the variable negative limit for the ramp-function generator and output** (also refer to Section 10.1, Sheet 14)

Number of the connector which is fed to the variable negative limit for the ramp-function generator and output.

Note:

If the selected connector has a positive value, this results in a positive minimum speed setpoint being entered.

Factory setting: 2 (it has the same effect as the signal from P620.II with the opposite sign)

Value range: 0 to 399 (connector number)

Access: 30

Change: off-line

Index ii = 00 to 03

**P622.ii Selecting the input of the speed controller setpoint limiting**

(also refer to Section 10.1, Sheet 14)

Number of the connector, which is fed to the input of the speed controller setpoint limiting

Factory setting: 2 (ramp-function generator output)

Value range: 0 to 399 (connector number)

Access: 30

Change: off-line

Index ii = 00 to 03

**P623.ii Selecting the ramp-function generator input**

(also refer to Section 10.1, Sheet 13)

Number of the connector which is fed to the ramp-function generator input.

Factory setting: 2 (output of the ramp-function generator setpoint limiting)

Value range: 0 to 399 (connector number)

Access: 30

Change: off-line

Index ii = 00 to 03

**P624.ii Selecting the reduction signal for the ramp-function generator times**

(also refer to Section 10.1, Sheet 14)

Number of the connector which acts on the reduction signal for the ramp-function generator times

P624.00 influences the ramp-up and ramp-down times (P303, P304)

P624.01 influences the initial- and final rounding-off (P305, P306) from SW2.00

Factory setting: 2 (fixed value 100%, no reduction in the ramp-function generator times)

Value range: 0 to 399 (connector number)

Access: 30

Change: off-line

Index ii = 00 to 01

**P625.ii Selecting the variable positive limit for the ramp-function generator input**

(also refer to Section 10.1, Sheet 13)

Number of the connector which is fed to the variable positive limit for the ramp-function generator input.

Factory setting: 2 (no variable positive limiting)

Value range: 0 to 399 (connector number)

Access: 30

Change: off-line

Index ii = 00 to 03

**P626.ii Selecting the variable negative limit for the ramp-function generator input**

(also refer to Section 10.1, Sheet 13)

Number of the connector which is fed to the variable negative limit for the ramp-function generator input.

Factory setting: 2 (it acts the same as the signal from P625.ii with the opposite sign)

Value range: 0 to 399 (connector number)

Access: 30

Change: off-line

Index ii = 00 to 03

**P627.ii Selecting the setpoint input after setpoint enable**

(also refer to Section 10.1, Sheet 12)

Number of the connector which is fed to the setpoint input after setpoint enable.

Factory setting: 2 (main setpoint)

Value range: 0 to 399 (connector number)

Access: 30

Change: off-line

Index ii = 00 to 03

**P628.ii Selecting the setpoint input before setpoint enable**

(also refer to Section 10.1, Sheet 12)

Number of the connector which is fed to the setpoint input before setpoint enable.

Factory setting: 2 (main setpoint)

Value range: 0 to 399 (connector number)

Access: 30

Change: off-line

Index ii = 00 to 03

**P629 Selecting the ramp-function generator setting value from SW2.00**

(also refer to Section 10.1, Sheet 14)

Number of the connector which is used in the following situations to set the ramp-function generator:

- in all operating statuses  $\geq 01.0$
- for P500  $\neq 2$  (torque setpoint from the slave drive does not come from the speed setpoint path) AND P084 = 2 (closed-loop current/torque operation)
- for P500  $\neq 2$  (torque setpoint from the slave drive does not come from the speed setpoint path) AND BEF41 = 1 ("slave operation")

2 In these cases, the ramp-function generator is set to  $n_{act}$  (K167)

Factory setting: 2

Value range: 0 to 399 (connector number)

Access: 30

Change: off-line

**Settings for structuring the technology controller****P630.ii Selecting the technology controller setpoint from SW1.10**

(also refer to Section 10.1, Sheet 10)

Number of the connector which is fed to the technology controller setpoint input.

Factory setting: 2 (fixed value 0%)

Value range: 0 to 399 (connector number)

Access: 30

Change: off-line

Index ii = 00 to 03

**P631.ii Selecting the technology controller actual value** **from SW1.10**

(also refer to Section 10.1, Sheet 10)

Number of the connector which is fed to the technology controller actual value input.

Factory setting: 2 (fixed value 0%) Value range: 0 to 399 (connector number)

Access: 30 Change: off-line Index ii = 00 to 03

**P632 Selecting the variable positive limit for the technology controller output** **from SW2.00**

(also refer to Section 10.1, Sheet 10)

Number of the connector, which, after multiplication with parameter P430, is fed to the variable positive limit for the technology controller output.

Factory setting: 2 (100% fixed value, no variable positive limiting)

Value range: 0 to 399 (connector number)

Access: 30 Change: off-line

**P633 Selecting the variable evaluation factor for the technology controller output** **from SW1.10**

(also refer to Section 10.1, Sheet 10)

Number of the connector, which, after multiplication with P428 evaluates the technology controller output.

Factory setting: 2 (100% fixed value, fixed evaluation of the technology controller output with P428)

Value range: 0 to 399 (connector number)

Access: 30 Change: on-line

**P634 Selecting the variable negative limit for the technology controller output** **from SW2.00**

(also refer to Section 10.1, Sheet 10)

Number of the connector, which after multiplication with P431, is fed to the variable negative limit for the technology controller output.

Factory setting: 2 (has the same effect as the signal from P632 with the opposite polarity)

Value range: 0 to 399 (connector number)

Access: 30 Change: off-line

**Settings for structuring the acceleration switch-in****P635.ii Selecting the acceleration switch-in supplementary value** **from SW1.10**

(also refer to Section 10.1, Sheet 16)

Number of the connector, which serves as supplementary torque setpoint.

Factory setting: 2 (acceleration switch-in according to P545)

Value range: 0 to 399 (connector number)

Access: 20 Change: off-line Index ii = 00 to 03

## Settings for structuring the converter open-loop control

### **P640** Selecting the data source for control word STW **from SW1.10**

(also refer to Section 10.1, Sheet 6 and 10.5.1 and alarm for P642)

Number of the connector, which supplies STW with data.

The functions, specified by STW are logically gated with the terminal functions and the functions, specified by STWF (e.g. ANDing the function "voltage disconnect, low active").

For P640 = 19, STW is ineffective

Factory setting: 19                      Value range: 19 to 83 (connector number)

Access: 30                                  Change: off-line

### **P641** Selecting the data source for the freely-definable control word STWF

**from SW1.10**

(also refer to Section 10.1, Sheet 6 and 10.5.2 and alarm for P642)

Number of the connector which supplies STWF with data.

The functions, defined by STWF (using parameter 642.ii), are logically gated with the terminal functions, and functions specified by STW (e.g. ANDing the function "disconnect voltage, low active").

For P641 = 19, STWF is ineffective (even if, individual indices of P642.ii, are assigned functions).

Factory setting: 19                      Value range: 19 to 83 (connector number)

Access: 30                                  Change: off-line

### **P642.ii** Selecting the functions of the bits of the freely-definable control word STWF

**from SW1.10**

(also refer to Section 10.1, Sheet 6 and 10.5.2)

The parameter values at the individual indices ii (ii = 0 to 15) of this parameter, are the numbers of those binary input functions, which are assigned the appropriate bits ii (ii = 0 to 15) of the STWF:

P642.00 defines the function of bit 0 of the STWF

P642.01 defines the function of bit 1 of the STWF

to

P642.15 defines the function of bit 15 of the STWF

Factory setting: 0 (no function)

Value range: 0 to 68 (number of the binary input function)

Access: 30

Change: off-line

Index ii = 00 to 15



#### **WARNING**



When changing parameters P640 to P642 undesirable structure changes or switch-on commands can occur (and thus the motor can start to rotate), if the appropriate bit is set. Thus, it should be ensured, that no voltage is present at the power terminals or at least there is no operating enable, as long as these parameters are being changed.

## Settings for freely-definable function blocks

### **P650.ii** Selecting the input for adder 1 **from SW2.00**

(also refer to Section 10.1, Sheet 7)

Factory setting: 2 (0%)      Value range: 0 to 399 (connector number)  
 Access: 20                      Change: off-line                      Index ii = 00 and 01

### **P651.ii** Selecting input A for multiplier/divider 1 **from SW2.00**

(also refer to P680 and Section 10.1, Sheet 7)

Factory setting: 2 (0%)      Value range: 0 to 399 (connector number)  
 Access: 20                      Change: off-line                      Index ii = 00 and 01

### **P652** Selecting input B for multiplier/divider 1 **from SW2.00**

(also refer to P680 and Section 10.1, Sheet 7)

Factory setting: 2 (0%)      Value range: 0 to 399 (connector number)  
 Access: 20                      Change: off-line

### **P653.ii** Selecting input A for the divider **from SW2.00**

(also refer to P684 and Section 10.1, Sheet 7)

Factory setting: 2 (0%)      Value range: 0 to 399 (connector number)  
 Access: 20                      Change: off-line                      Index ii = 00 and 01

### **P654** Selecting input B for the divider **from SW2.00**

(also refer to P684 and Section 10.1, Sheet 7)

Factory setting: 2 (0%)      Value range: 0 to 399 (connector number)  
 Access: 20                      Change: off-line

### **P655** Selecting the input for inverter 1 **from SW2.00**

(also refer to Section 10.1, Sheet 8)

Factory setting: 2 (0%)      Value range: 0 to 399 (connector number)  
 Access: 20                      Change: off-line

### **P656.ii** Selecting the input A for changeover switch 1 **from SW2.00**

(also refer to Section 10.1, Sheet 8)

Factory setting: 2 (0%)      Value range: 0 to 399 (connector number)  
 Access: 20                      Change: off-line                      Index ii = 00 and 01

- P657 Selecting input B for changeover switch 1** **from SW2.00**  
 (also refer to Section 10.1, Sheet 8)  
 Factory setting: 2 (0%)      Value range: 0 to 399 (connector number)  
 Access: 20      Change: off-line
- P658 Selecting the input for absolute value generator 1** **from SW2.00**  
 (also refer to Section 10.1, Sheet 9)  
 Factory setting: 2 (0%)      Value range: 0 to 399 (connector number)  
 Access: 20      Change: off-line
- P659 Selecting input A for limit value monitor 1** **from SW2.00**  
 (also refer to P692, Section 10.1, Sheet 9 and 10.4.34)  
 Factory setting: 2 (0%)      Value range: 0 to 399 (connector number)  
 Access: 20      Change: off-line
- P660 Selecting input B for limit value monitor 1** **from SW2.00**  
 (also refer to P692, Section 10.1, Sheet 9 and 10.4.34)  
 Factory setting: 2 (0%)      Value range: 0 to 399 (connector number)  
 Access: 20      Change: off-line
- P661.ii Selecting the input for adder 2** **from SW2.00**  
 (also refer to Section 10.1, Sheet 7)  
 Factory setting: 2 (0%)      Value range: 0 to 399 (connector number)  
 Access: 20      Change: off-line      Index ii = 00 and 01
- P662.ii Selecting input A for multiplier / divider 2** **from SW2.00**  
 (also refer to P681 and Section 10.1, Sheet 7)  
 Factory setting: 2 (0%)      Value range: 0 to 399 (connector number)  
 Access: 20      Change: off-line      Index ii = 00 and 01
- P663 Selecting input B for multiplier / divider 2** **from SW2.00**  
 (also refer to P681 and Section 10.1, Sheet 7)  
 Factory setting: 2 (0%)      Value range: 0 to 399 (connector number)  
 Access: 20      Change: off-line



- P664 Selecting the input for the characteristic** **from SW2.00**  
 (also refer to Section 10.1, Sheet 7)  
 The number of the connector, which serves as X input value for the characteristic. For this particular X input value, the associated Y output value is calculated by linearly interpolating between the characteristic points, defined by parameter 698.ii and P699.ii; Output value Y is available at connector K237.  
 For X input values less than P698.00 or greater than P698.09, the characteristic is extended horizontally, i.e. P699.00 or P699.09 are obtained as Y output values.  
 Factory setting: 2 (0%)      Value range: 0 to 399 (connector number)  
 Access: 20      Change: off-line
- P665 Selecting the input for inverter 2** **from SW2.00**  
 (also refer to Section 10.1, Sheet 8)  
 Factory setting: 2 (0%)      Value range: 0 to 399 (connector number)  
 Access: 20      Change: off-line
- P666.ii Selecting input A for changeover switch 2** **from SW2.00**  
 (also refer to Section 10.1, Sheet 8)  
 Factory setting: 2 (0%)      Value range: 0 to 399 (connector number)  
 Access: 20      Change: off-line      Index ii = 00 and 01
- P667 Selecting input B for changeover switch 2** **from SW2.00**  
 (also refer to Section 10.1, Sheet 8)  
 Factory setting: 2 (0%)      Value range: 0 to 399 (connector number)  
 Access: 20      Change: off-line
- P668 Selecting the input for the limiter** **from SW2.00**  
 (also refer to Section 10.1, Sheet 8)  
 Factory setting: 2 (0%)      Value range: 0 to 399 (connector number)  
 Access: 20      Change: off-line
- P669 Selecting the input for absolute value generator 2** **from SW2.00**  
 (also refer to Section 10.1, Sheet 9)  
 Factory setting: 2 (0%)      Value range: 0 to 399 (connector number)  
 Access: 20      Change: off-line
- P670 Selecting input A for limit value monitor 2** **from SW2.00**  
 (also refer to P694, Section 10.1, Sheet 9 and 10.4.35)  
 Factory setting: 2 (0%)      Value range: 0 to 399 (connector number)  
 Access: 20      Change: off-line

- P671 Selecting input B for limit value monitor 2** **from SW2.00**  
 (also refer to P694, Section 10.1, Sheet 9 and 10.4.35)  
 Factory setting: 2 (0%)      Value range: 0 to 399 (connector number)  
 Access: 20      Change: off-line
- P672.ii Selecting the input for adder 3** **from SW2.00**  
 (also refer to Section 10.1, Sheet 7)  
 Factory setting: 2 (0%)      Value range: 0 to 399 (connector number)  
 Access: 20      Change: off-line      Index ii = 00 and 01
- P673.ii Selecting input A for multiplier / divider 3** **from SW2.00**  
 (also refer to P682 and Section 10.1, Sheet 7)  
 Factory setting: 2 (0%)      Value range: 0 to 399 (connector number)  
 Access: 20      Change: off-line      Index ii = 00 and 01
- P674 Selecting input B for multiplier / divider 3** **from SW2.00**  
 (also refer to P682 and Section 10.1, Sheet 7)  
 Factory setting: 2 (0%)      Value range: 0 to 399 (connector number)  
 Access: 20      Change: off-line
- P675 Selecting the input for inverter 3** **from SW2.00**  
 (also refer to Section 10.1, Sheet 8)  
 Factory setting: 2 (0%)      Value range: 0 to 399 (connector number)  
 Access: 20      Change: off-line
- P676.ii Selecting input A for changeover switch 3** **from SW2.00**  
 (also refer to Section 10.1, Sheet 8)  
 Factory setting: 2 (0%)      Value range: 0 to 399 (connector number)  
 Access: 20      Change: off-line      Index ii = 00 and 01
- P677 Selecting input B for changeover switch 3** **from SW2.00**  
 (also refer to Section 10.1, Sheet 8)  
 Factory setting: 2 (0%)      Value range: 0 to 399 (connector number)  
 Access: 20      Change: off-line
- P679 Threshold for the dead range** **from SW2.00**  
 (also refer to Section 10.1, Sheet 7)  
 The output at K093 is that part of the input signal (K159), whose absolute value exceeds this threshold.  
 Factory setting: 1.00%      Value range (steps): 0.00 to 100.00% (0.01%)  
 Access: 20      Change: on-line

**P680 Multiplication factor for multiplier / divider 1****from SW2.00**

(also refer to Section 10.1, Sheet 7)

0.0 Multiplier / divider 1 operates as divider

$$\text{Output} = \frac{\text{input A}}{\text{input B}} * 100\%$$

x.x Multiplier / divider 1 operates as multiplier

$$\text{Output} = \frac{\text{input A}}{100\%} * \text{input B} * \text{P680}$$

Input A is the sum of the connectors selected with P651.ii  
 Input B is selected using P652

Factory setting: 1.0

Value range (steps): -1000.0 to 1000.0 (0.1)

Access: 20

Change: on-line

**P681 Multiplication factor for multiplier / divider 2****from SW2.00**

(also refer to Section 10.1, Sheet 7)

0.0 Multiplier / divider 2 operates as divider

$$\text{Output} = \frac{\text{input A}}{\text{input B}} * 100\%$$

x.x Multiplier / divider 2 operates as multiplier

$$\text{Output} = \frac{\text{input A}}{100\%} * \text{input B} * \text{P681}$$

Input A in the sum of the connectors selected with P662.ii  
 Input B is selected using P663

Factory setting: 1.0

Value range (steps): -1000.0 to 1000.0 (0.1)

Access: 20

Change: on-line

**P682 Multiplication factor for multiplier / divider 3****from SW2.00**

(also refer to Section 10.1, Sheet 7)

0.0 Multiplier / divider 3 operates as divider

$$\text{Output} = \frac{\text{input A}}{\text{input B}} * 100\%$$

x.x Multiplier / divider 3 operates as multiplier

$$\text{Output} = \frac{\text{input A}}{100\%} * \text{input B} * \text{P682}$$

Input A is the sum of the connectors selected with P673.ii  
 Input B is selected using P674

Factory setting: 1.0

Value range (steps): -1000.0 to 1000.0 (0.1)

Access: 20

Change: on-line

**P683 Minimum diameter****from SW2.00**

(also refer to P684 and Section 10.1, Sheet 7)

Diameter D, selected using P654 (and for P084 = 3, converted to mm using P697) is limited (lower limit) to the value set at his parameter, in order to prevent division by speeds which are too low.

Factory setting: 10000mm

Value range (steps): 1 to 10000mm (1mm)

Access: 20

Change: on-line

**P684 Control word for the divider****from SW2.00**

(also refer to Section 10.1, Sheet 7)

- 1 Operation as general, free divider, i.e.

$$\text{Output} = \frac{\text{input A}}{\text{input B}} * 100\%$$

Input A is the sum of all the connenctors selected using P653.ii

Input B is selected using P654

P683, P696 and P697 have no effect

- 2 Operation as speed setpoint calculator with "mm" inputs, i.e.

$$n_{\text{set}} = \frac{v_{L \text{ set}} * 10}{D} * \frac{100\%}{\Pi * \frac{nP450 + nP451}{60}}$$

whereby

$n_{\text{set}}$  Speed setpoint as a % of  $n_{\text{max}}$ , is available at connector K245

$v_{L \text{ set}}$  Speed setpoint in mm/s (range: -32768 to 32767mm/s)  
(selected using P653.ii)

D Diameter in 0.1 mm (range: 0.1 to 6553.5 mm) (selected using P654)  
(diameter D converted into mm, has a lower limit defined by P683)

$nP450 + nP451$  ( $n = 1$  to  $4$ ) maximum revolution of the shaft at the at the drive-out end of a mechanical gearbox (4 different values can be selected for P450 + P451 (parameter sets 1 to 4), depending on the gearbox ratio)

P696 and P697 are ineffective

- 3 Operation as speed setpoint calculator with % inputs, i.e.

$$n_{\text{set}} = \frac{v_{L \text{ set}} * \frac{P696}{100\%}}{D * \frac{P697}{100\%}} * \frac{100\%}{\Pi * \frac{nP450 + nP451}{60}}$$

whereby

$n_{\text{set}}$  Speed setpoint as a % of  $n_{\text{max}}$ , is available at connector K245

$v_{L \text{ set}}$  Speed setpoint as a % of P696 (input value 16384 corresponds to 100%, selected using P653.ii)

D Diameter as a % of P697 (the input value 16394 corresponds to 100%, selected using P654) (diameter D, converted into mm, is limited (lower limit) using P683)

$nP450 + nP451$  ( $n = 1$  to  $4$ ) maximum shaft speed at the gearbox output (4 different values can be selected for P450 + P451 (parameter sets 1 to 4), depending on the gearbox ratio)

Factory setting: 1

Value range: 1 to 3

Access: 20

Change: off-line

- P686 Upper limit of the limiter** **from SW2.00**  
 (also refer to Section 10.1, Sheet 8)  
 Factory setting: 100.00%      Value range (steps): -200.0 to 199.99% (0.01%)  
 Access: 20      Change: on-line
- P687 Lower limit of the limiter** **from SW2.00**  
 (also refer to Section 10.1, Sheet 8)  
 Factory setting: -100.0%      Value range (steps): -200.0 to 199.99% (0.01%)  
 Access: 20      Change: on-line
- P688 Control word for absolute value generator 1** **from SW2.00**  
 (also refer to Section 10.1, Sheet 9)  
 0 With correct sign  
 1 Absolute value  
 2 Inverted  
 3 Absolute value, inverted  
 Factory setting: 0      Value range: 0 to 3  
 Access: 20      Change: off-line
- P689 Filter time for filter 1** **from SW2.00**  
 (also refer to Section 10.1, Sheet 9)  
 Factory setting: 0ms      Value range (steps): 0 to 10000ms (1ms)  
 Access: 20      Change: on-line
- P690 Control word for absolute value generator 2** **from SW2.00**  
 (also refer to Section 10.1, Sheet 9)  
 0 With correct sign  
 1 Absolute value  
 2 Inverted  
 3 Absolute value, inverted  
 Factory setting: 0      Value range: 0 to 3  
 Access: 20      Change: off-line
- P691 Filter time for filter 2** **from SW2.00**  
 (also refer to Section 10.1, Sheet 9)  
 Factory setting: 0ms      Value range: 0 to 10000ms  
 Access: 20      Change: on-line

**P692 Control word for limit value monitor 1 from SW2.00**

(also refer to Section 10.1, Sheet 9 and 10.4.34)

- 1 A < B, results in logical 1
- 2 A = B, results in logical 1

Input A is selected by P659, input B by P660, hysteresis according to P693.

Factory setting: 1 Value range: 1 to 2

Access: 20 Change: off-line

**P693 Hysteresis, limit value monitor 1 from SW2.00**

(also refer to P692, Section 10.1, Sheet 9 and 10.4.34)

Factory setting: 0.00% Value range: 0.00 to 199.99%

Access: 20 Change: on-line

**P694 Control word for limit value monitor 2 from SW2.00**

(also refer to Section 10.1, Sheet 9 and 10.4.35)

- 1 A < B, results in logical 1
- 2 A = B, results in logical 1

Input A is selected by P670, input B by P671, hysteresis according to P695.

Factory setting: 1 Value range: 1 to 2

Access: 20 Change: off-line

**P695 Hysteresis, limit value monitor 2 from SW2.00**

(also refer to P694, Section 10.1, Sheet 9 and 10.4.35)

Factory setting: 0.00% Value range: 0.00 to 199.99%

Access: 20 Change: on-line

**P696 Normalization, speed setpoint from SW2.00**

(also refer to P684 and Section 10.1, Sheet 7)

This parameter specifies, which speed setpoint in mm/s, corresponds to an input value of 100%.

Factory setting: 100mm/s Value range: 1 to 32767mm/s

Access: 20 Change: off-line

**P697 Normalization, diameter from SW2.00**

(also refer to P684 and Section 10.1, Sheet 7)

This parameter specifies, which diameter in mm/s, corresponds to an input value of 100%.

Factory setting: 10000mm Value range: 1 to 32767mm

Access: 20 Change: off-line

**P698.ii Characteristic points, x values****from SW2.00**

(also refer to P664 and Section 10.1, Sheet 7)

The points of the free characteristic should be set as associated x, y pairs, in parameters P698 and P699.

Caution:

The x values must be set in an increasing sequence, i.e. the value in P698.ii must be greater than the value in P698.ii-1!

Factory setting: 0.00%

Value range: -200.0 to 199.99% (0.01%)

Access: 20

Change: on-line

Index ii = 00 to 09

**P699.ii Characteristic points, y values****from SW2.00**

(also refer to P664 and Section 10.1, Sheet 7)

The points of the free characteristic should be set as associated x, y pairs, in parameters P698 and P699.

Caution:

The y values associated with P698.ii must be set in P699.ii!

Factory setting: 0.00%

Value range: -200.0 to 199.99% (0.01%)

Access: 20

Change: on-line

Index ii = 00 to 09

**Definition of the basic converter hardware interface****Analog inputs****P700 Main setpoint resolution (terminals 4 and 5)****from SW2.00**

(also refer to Section 10.1, Sheet 2)

The main setpoint, connected at terminals 4 and 5, are averaged over a specific measuring time. This parameter specifies the minimum achievable resolution of the A/D conversion (in bits), and specifies the measuring time (refer to the table below).

The main setpoint A/D conversion is realized cyclically. The duration of a conversion cycle is dependent on the measuring time (refer to Table below), and is therefore a measure of the delay time when placing an analog step, until the earliest availability of a digital value for internal processing. The A/D converted digital value is read-out once per firing cycle in synchronism to this.

Hardware filtering before A/D conversion: Time constant = 1ms

| P700 | Resolution better than | Measuring time | Quantizing steps referred to 16384 | Maximum duration of a conversion cycle |
|------|------------------------|----------------|------------------------------------|--|
| 10   | ± 10 bit               | 0.1422ms       | 14.55                              | 0.4164ms                               |
| 11   | ± 11 bit               | 0.2844ms       | 7.27                               | 0.7009ms                               |
| 12   | ± 12 bit               | 0.5689ms       | 3.64                               | 1.2698ms                               |
| 13   | ± 13 bit               | 1.1378ms       | 1.82                               | 2.4076ms                               |
| 14   | ± 14 bit               | 2.2756ms       | 0.91                               | 4.6831ms                               |

Factory setting: 12 bits

Value range (steps): 10 to 14 bits (1 bit)

Access: 40

Change: off-line

## Definition of the basic converter hardware interface

### Analog inputs

#### **P701 Normalization, main setpoint (terminals 4 and 5)**

(also refer to Section 10.1, Sheet 2)

This parameter defines, which % value is generated for 10V input at the analog main setpoint (or an input current of 20 mA).

Generally valid:

For voltage input:

$$P701 [\%] = \frac{10V}{X} * Y$$

X... Input voltage in volts

Y... % value which is generated for an input voltage X

For current input:

$$P701 [\%] = \frac{20mA}{X} * Y$$

X... Input current in amps

Y... % value which is generated for an input current X

Factory setting: 100%

Value range (steps): -1000 to 1000% (1%)

Access: 20

Change: on-line

#### **P702 Main setpoint offset (terminals 4 and 5)**

(also refer to Section 10.1, Sheet 2)

Value which is added to the main setpoint

Factory setting: 0 \* 0.0061%

Value range (steps): -1000 to 1000 \* 0.0061% (1 \* 0.0061%)  
-9999 to 16384 \* 0.0061%

from SW2.00

Access: 20

Change: on-line

#### **P703 Main setpoint control word (terminals 4 and 5)**

(also refer to Section 10.1, Sheet 2)

- x0 Signal input with the correct sign
- x1 The absolute signal value is input
- x2 Signal is input with the correct sign, inverted
- x3 The absolute signal value is input, inverted
- 0x Operation as voltage input ( $\pm 10V$ )  
(switch S4 on board A1600 in position 1)
- 1x Operation as current input (4 to 20mA)  
(switch S4 on board A1600 in position 2)
- 2x Operation as current input (0 to 20mA)  
(switch S4 on board A1600 in position 2)

For operation as "current input" the polarity can be reversed using a binary select input assigned to a binary input function "polarity, analog input main setpoint" (BEF48), assigned to a binary select input (refer to Section 10.3.48).

Factory setting: 00

Value range (steps): 00 to 23 (1 hex)

Access: 20

Change: off-line



**P704 Filter time for the main setpoint (terminals 4 and 5)**

(also refer to Section 10.1, Sheet 2)

This is supplemented by a fixed hardware filter of approx. 1 ms.

Factory setting: 0ms                      Value range (steps): 0 to 10000ms (1ms)

Access: 20                                      Change: on-line

**P706 Normalization for the main actual value (terminals XT-101 to XT-104)**

(also refer to Section 10.1, Sheet 2)

Nominal input voltage at  $n_{max}$  (= tachometer voltage at maximum speed)  
For P083 = 1, this parameter defines the maximum speed.

Factory setting: 60.00V                      Value range (steps): -270.00 to 270.00V (0.01V)

Access: 20                                      Change: on-line

**P707 Offset of the main actual value (terminals XT-101 to XT-104)**

(also refer to Section 10.1, Sheet 2)

Value which is added to the main actual value.

Factory setting: 0 \* 0.0061%

Value range (steps):                      -1000 to 1000 \* 0.0061% (1 \* 0.0061%)

Access: 20                                      Change: on-line

**P708 Control word for the main actual value (terminals XT-101 to XT-104)**

(also refer to Section 10.1, Sheet 2)

- x0 Signal is input with the correct sign
- x1 The absolute signal value is input
- x2 Signal is input with sign, inverted
- x3 The absolute signal value is input, inverted

- 0x Nothing is connected at terminals XT-101 to XT-103
- 1x Main actual value connected at terminal XT-101 (range, 80 to 250V)
- 2x Main actual value connected at terminal XT-102 (range, 25 to 80V)
- 3x Main actual value connected at terminal XT-103 (range, 8 to 25V)

Factory setting: 20                              Value range (steps): 00 to 33 (1 hex)

Access: 20                                      Change: off-line

**P709 Filter time for the main actual value (terminals XT-101 to XT-104)**

(also refer to Section 10.1, Sheet 2)

This is supplemented by a fixed hardware filter of approx. 1ms.

From SW2.00, for P083 = 1, P709 will be taken into account in the speed controller optimization run (P051 = 26).

Factory setting: 0ms                              Value range (steps): 0 to 10000ms (1ms)

Access: 20                                      Change: on-line

**P710 Resolution, analog select input 1 (terminals 6 and 7) from SW2.00**

Analog setpoint input 1, connected at terminals 6 and 7, is averaged over a specific measuring time. This parameter specifies the minimum, achievable resolution of the A/D conversion (in bits), and specified measuring time (refer to the table below).

The A/D conversion of analog setpoint 1 is realized cyclically. The duration of a conversion cycle is dependent on the measuring time (refer to Table below), and is therefore a measure of the delay time when placing an analog step, until the earliest availability of a digital value for internal processing. The A/D converted digital value is read-out once per firing cycle in synchronism to this.

Hardware filtering before A/D conversion: Time constant = 1ms

| P700 | Resolution better than | Measuring time | Quantizing steps referred to 16384 | Maximum duration of a conversion cycle |
|------|------------------------|----------------|------------------------------------|--|
| 10   | ± 10 bit               | 0.1422ms       | 14.55                              | 0.4164ms                               |
| 11   | ± 11 bit               | 0.2844ms       | 7.27                               | 0.7009ms                               |
| 12   | ± 12 bit               | 0.5689ms       | 3.64                               | 1.2698ms                               |
| 13   | ± 13 bit               | 1.1378ms       | 1.82                               | 2.4076ms                               |
| 14   | ± 14 bit               | 2.2756ms       | 0.91                               | 4.6831ms                               |

Factory setting: 12 bits

Value range (steps): 10 to 14 bits (1 bit)

Access: 40

Change: off-line

**P711 Normalization, analog select input 1 (terminals 6 and 7)**

(also refer to Section 10.1, Sheet 2)

This parameter defines, which % value is generated for 10V input at the analog setpoint input (or an input current of 20 mA).

Generally valid:

For voltage input:

$$P701 [\%] = \frac{10V}{X} \cdot Y$$

X ... Input voltage in volts

Y ... % value which is generated for an input voltage X

For current input:

$$P701 [\%] = \frac{20mA}{X} \cdot Y$$

X ... Input current in amps

Y ... % value which is generated for an input current X

Factory setting: 100%

Value range (steps): -1000 to 1000% (1%)

Access: 20

Change: on-line

**P712 Offset for analog select input 1 (terminals 6 and 7)**

(also refer to Section 10.1, Sheet 2)

Value is added to analog select input 1

Factory setting: 0 \* 0.0061%

Value range (steps): -1000 to 1000 \* 0.0061% (1 \* 0.0061%)  
-9999 to 16384 \* 0.0061%

from SW2.00

Access: 20

Change: on-line

**P713 Control word for analog select input 1 (terminals 6 and 7)**

(also refer to Section 10.1, Sheet 2)

- x0 Signal is input with the correct sign
- x1 The absolute signal value is input
- x2 Signal is input with sign, inverted
- x3 The absolute signal value is input, inverted
  
- 0x Operation as voltage input ( $\pm 10V$ )  
(switch S5 on board A1600 in position 1)
- 1x Operation as current input (4 to 20mA)  
(switch S5 on board A1600 in position 2)
- 2x Operation as current input (0 to 20mA)  
(switch S5 on board A1600 in position 2)

For operation as "current input" the polarity can be reversed using a binary select input function assigned to a binary select input "polarity, analog input main setpoint" (BEF50) (refer to Section 10.3.50).

Factory setting: 00

Value range (steps): 00 to 23 (1Hex)

Access: 20

Change: off-line

**P714 Filter time for analog select input 1 (terminals 6 and 7)**

(also refer to Section 10.1, Sheet 2)

This is supplemented by a fixed hardware filter of approx. 1 ms.

Factory setting: 0ms

Value range (steps): 0 to 10000ms (1ms)

Access: 20

Change: on-line

**P716 Normalization, analog select input 2 (terminal 8)**

(also refer to Section 10.1, Sheet 2)

This parameter defines what % value is generated for 10V input at the analog select input 2.

Generally valid:

$$P716 [\%] = \frac{10V}{X} * Y$$

X... Input voltage in volts

Y... % value which is generated at input voltage X

Factory setting: 100%

Value range (steps): -1000 to 1000% (1%)

Access: 20

Change: on-line

**P717 Offset for analog select input 2 (terminal 8)**

(also refer to Section 10.1, Sheet 2)

The value is added to analog select input 2.

Factory setting: 0 \* 0.0061%

Value range (steps): -1000 to 1000 \* 0.0061% (1 \* 0.0061%)  
-9999 to 16384 \* 0.0061%

from SW2.00

Access: 20 Change: on-line

**P718 Control word for analog select input 2 (terminal 8)**

(also refer to Section 10.1, Sheet 2)

- 0 Signal is input with the correct sign
- 1 The absolute signal value is input
- 2 Signal is input with sign, inverted
- 3 The absolute signal value is input inverted

Factory setting: 0 Value range: 0 to 3

Access: 20 Change: off-line

**P719 Filter time for analog select input 2 (terminal 8)**

(also refer to Section 10.1, Sheet 2)

This is supplemented by a fixed hardware filter of approx. 1 ms.

Factory setting: 0ms Value range (steps): 0 to 10000ms (1ms)

Access: 20 Change: on-line

**P721 Normalization, analog select input 3 (terminal 10)**

(also refer to Section 10.1, Sheet 2)

This parameter defines what % value is generated for 10V input at analog select input 3.

Generally valid:

$$P721 [\%] = \frac{10V}{X} * Y$$

X... Input voltage in volts

Y... % value which is indicated for an input voltage X

Factory setting: 100% Value range (steps): -1000 to 1000% (1%)

Access: 20 Change: on-line

**P722 Offset for analog select input 3 (terminal 10)**

(also refer to Section 10.1, Sheet 2)

The value is added to analog select input 3.

Factory setting: 0 \* 0.0061%

Value range (steps): -1000 to 1000 \* 0.0061% (1 \* 0.0061%)  
-9999 to 16384 \* 0.0061%

from SW2.00

Access: 20 Change: on-line

**P723 Control word for analog select input 3 (terminal 10)**

(also refer to Section 10.1, Sheet 2)

- 0 Signal is input with sign
- 1 Absolute signal value is input
- 2 Signal is input with sign, inverted
- 3 Absolute signal value is input, inverted

Factory setting: 0                      Value range: 0 to 3

Access: 20                                Change: off-line

**P724 Filter time for analog select input 3 (terminal 10)**

(also refer to Section 10.1, Sheet 2)

This is supplemented by a fixed hardware filter of approx. 1 ms.

Factory setting: 0ms                      Value range (steps): 0 to 10000ms (1ms)

Access: 20                                Change: on-line

**Analog outputs****P739 Control word for terminal 12 (current actual value display)**

(also refer to Section 10.1, Sheet 3)

- 0 Output with correct sign  
(positive voltage: Current in torque direction M I )  
(negative voltage: Current in torque direction M II)
- 1 Absolute value is output (only positive voltage)
- 2 Output with sign, inverted  
(positive voltage: current in torque direction M II)  
(negative voltage: Current in torque direction M I )
- 3 The absolute value is output, inverted (only negative voltage)

Factory setting: 0                      Value range: 0 to 3

Access: 20                                Change: on-line

**P740 Selecting the function of terminal 14 (analog select output 1)**

(also refer to Section 10.1, Sheet 3 and 10.2)

Number of the "connector", whose value is to be output at the analog output

- 0 Fixed value 0% (= connector K000)
- 1 Connector K001
- 2 0%
- 3 Connector K003
- to
- 399 Connector K399

Factory setting: 0 Value range: 0 to 399 (connector number)

Access: 20 Change: on-line

**P741 Control word for analog select output 1 (terminal 14)**

(also refer to Section 10.1, Sheet 3)

- 0 Signal is input with the correct sign
- 1 Absolute signal value is input
- 2 Signal is input with sign, inverted
- 3 Absolute signal value is input, inverted

Factory setting: 0 Value range: 0 to 3

Access: 20 Change: on-line

**P742 Filter time for analog select output 1 (terminal 14)**

(also refer to Section 10.1, Sheet 3)

This is supplemented by a fixed hardware filter of approx. 1ms.

Factory setting: 0ms Value range (steps): 0 to 10000ms (1ms)

Access: 20 Change: on-line

**P743 Offset for analog select output 1 (terminal 14)**

(also refer to Section 10.1, Sheet 3)

Factory setting:  $0 * 5.33\text{mV}$  Value range (steps):  $-1000$  to  $1000 * 5.33\text{mV}$  ( $1 * 5.33\text{mV}$ )  
 $-2000$  to  $2000 * 5.33\text{mV}$  from  
 SW2.00

Access: 20 Change: on-line

**P744 Normalization for analog select output 1 (terminal 14)**

(also refer to Section 10.1, Sheet 3)

$$V_A [\text{V}] = \frac{\text{Connector} [\%]}{100\%} * P744$$

whereby  $V_A$  ... output voltage at terminal 14 with respect to terminal 15

Factory setting: 10.00V Value range (steps):  $-10.50$  to  $10.50\text{V}$  (0.01V)  
 $-200.0$  to  $200.00\text{V}$  (0.01V) from SW2.00

Access: 20 Change: on-line

**P745 Selecting the function of terminal 16 (analog select output 2)**

(also refer to Section 10.1, Sheet 3 and 10.2)

Number of the "connector" whose value is to be output at the analog output.

- 0 Fixed value 0% (= connector K000)
  - 1 Connector K001
  - 2 0%
  - 3 Connector K003
- to
- 399 Connector K399

Factory setting: 0 Value range: 0 to 399 (connector number)

Access: 20 Change: on-line

**P746 Control word for analog select output 2 (terminal 16)**

(also refer to Section 10.1, Sheet 3)

- 0 Signal is input with the correct sign
- 1 Absolute signal value is input
- 2 Signal is input with the correct sign, inverted
- 3 Absolute signal value is input, inverted

Factory setting: 0 Value range: 0 to 3

Access: 20 Change: on-line

**P747 Filter time for analog select output 2 (terminal 16)**

(also refer to Section 10.1, Sheet 3)

This is supplemented by a fixed hardware filter of approx. 1 ms.

Factory setting: 0ms Value range (steps): 0 to 10000ms (1ms)

Access: 20 Change: on-line

**P748 Offset for analog select output 2 (terminal 16)**

(also refer to Section 10.1, Sheet 3)

Factory setting:  $0 * 5.33\text{mV}$  Value range (steps):  $-1000$  to  $1000 * 5.33\text{mV}$  ( $1 * 5.33\text{mV}$ )  
 $-2000$  to  $2000 * 5.33\text{mV}$  from  
 SW2.00

Access: 20 Change: on-line

**P749 Normalization, analog select output 2 (terminal 16)**

(also refer to Section 10.1, Sheet 3)

$$V_A [\text{V}] = \frac{\text{Connector} [\%]}{100\%} * P749$$

whereby  $V_A$  . . . output voltage at terminal 16 with respect to terminal 17.

Factory setting: 10.00V Value range (steps):  $-10.50$  to  $10.50\text{V}$  (0.01V)  
 $-200.0$  to  $200.00\text{V}$  (0.01V) from SW2.00

Access: 20 Change: on-line

**P750 Selecting the function of terminal 18 (analog select output 3)**

(also refer to Section 10.1, Sheet 3 and 10.2)

Number of the "connector", whose value should be output at the analog output.

- 0 Fixed value 0% (= connector K000)
- 1 Connector K001
- 2 0%
- 3 Connector K003
- to
- 399 Connector K399

Factory setting: 0 Value range: 0 to 399 (connector number)

Access: 20 Change: on-line

**P751 Control word for analog select output 3 (terminal 18)**

(also refer to Section 10.1, Sheet 3)

- 0 Signal is input with the correct sign
- 1 Absolute signal value is input
- 2 Signal is input with the correct sign, inverted
- 3 Absolute signal value is input, inverted

Factory setting: 0 Value range: 0 to 3

Access: 20 Change: on-line

**P752 Filter time for analog select output 3 (terminal 18)**

(also refer to Section 10.1, Sheet 3)

This is supplemented by a fixed hardware filter of approx. 1 ms.

Factory setting: 0ms Value range (steps): 0 to 10000ms (1ms)

Access: 20 Change: on-line

**P753 Offset for analog select output 3 (terminal 18)**

(also refer to Section 10.1, Sheet 3)

Factory setting: 0 \* 5.33mV Value range (steps): -1000 to 1000 \* 5.33mV (1\* 5.33mV)  
 -2000 to 2000 \* 5.33mV from  
 SW2.00

Access: 20 Change: on-line

**P754 Normalization, analog select output 3 (terminal 18)**

(also refer to Section 10.1, Sheet 3)

$$V_A [V] = \frac{\text{connector} [\%]}{100\%} * P754$$

whereby  $V_A$  . . . output voltage at terminal 18 with respect to terminal 19.

Factory setting: 10.00V Value range (steps): -10.50 to 10.50V (0.01V)  
 -200.0 to 200.00V (0.01V) from SW2.00

Access: 20 Change: on-line



**P755 Selecting the function of terminal 20 (analog select output 4)**

(also refer to Section 10.1, Sheet 3 and 10.2)

Number of the "connector" whose value is to be output at the analog output.

0 Fixed value 0% (= connector K000)

1 Connector K001

2 0%

3 Connector K003

to

399 Connector K399

Factory setting: 0

Value range: 0 to 399 (connector number)

Access: 20

Change: on-line

**P756 Control word for analog select output 4 (terminal 20)**

(also refer to Section 10.1, Sheet 3)

0 Signal is input with the correct sign

1 Absolute signal value is input

2 Signal is input with the correct sign, inverted

3 Absolute signal value is input, inverted

Factory setting: 0

Value range: 0 to 3

Access: 20

Change: on-line

**P757 Filter time for analog select output 4 (terminal 20)**

(also refer to Section 10.1, Sheet 3)

This is supplemented by a fixed hardware filter of approx. 1 ms.

Factory setting: 0ms

Value range (steps): 0 to 10000ms (1ms)

Access: 20

Change: on-line

**P758 Offset for analog select output 4 (terminal 20)**

(also refer to Section 10.1, Sheet 3)

Factory setting: 0 \* 5.33mV

Value range (steps): -1000 to 1000 \* 5.33mV (1\* 5.33mV)  
-2000 to 2000 \* 5.33mV from  
SW2.00

Access: 20

Change: on-line

**P759 Normalization, analog select output 4 (terminal 20)**

(also refer to Section 10.1, Sheet 3)

$$V_A [V] = \frac{\text{Connector} [\%]}{100\%} * P759$$

Whereby  $V_A$  . . . output voltage at terminal 20 with respect to terminal 21

Factory setting: 10.00V

Value range (steps): -10.50 to 10.50V (0.01V)

-200.0 to 200.00V (0.01V) from SW2.00

Access: 20

Change: on-line

## Binary inputs

### P761 Selecting the function of terminal 39 (select input, binary 1)

(also refer to Section 10.1, Sheet 6 and 10.3)

Number of the binary input function which is assigned to terminal 39.

- 0 No function
- 1 Reserved
- 2 Binary input function 2
- x Refer to the list of binary input functions, Section 10.3

If P144 = xx2 or xx3, terminal 39 has, in addition to the function selected via P761, also the "reset position counter" function.

Factory setting: 0                      Value range: 0 to 68 (binary input function)

Access: 20                              Change: off-line



#### WARNING

When changing parameters P761 to P766, undesirable structure changes or switch-on commands (and thus the motor starts) can occur, if the appropriate terminal is energized.



Thus, it must be ensured that no binary select input is energized, as long as its function has still not been finally specified via the appropriate parameter. This can be simply realized by withdrawing ribbon cable connector XB!

From SW2.00 onwards, undesirable and erroneous motor starting with terminal energized can be prevented by internally entering "switch-on inhibit" when changing an offline parameter. That can result in operating status o8 (acknowledgement required).

### P762 Selecting the function of terminal 40 (select input, binary 2)

(also refer to Section 10.1, Sheet 6, 10.3 and alarm for P761)

Number of the binary input function, which is assigned to terminal 40.

- 0 No function
- 1 Reserved
- 2 Binary input function 2
- x Refer to the list of binary input functions, Section 10.3

Factory setting: 0                      Value range: 0 to 68 (binary input functions)

Access: 20                              Change: off-line

**P763 Selecting the function of terminal 41 (select input, binary 3)**

(also refer to Section 10.1, Sheet 6, 10.3 and alarm for P761)

Number of the binary input function, which is assigned to terminal 41.

- 0 No function
- 1 Reserved
- 2 Binary input function 2
- x Refer to a list of the binary input functions, Section 10.3

Factory setting: 0 Value range: 0 to 68 (binary input function)

Access: 20 Change: off-line

**P764.ii Selecting the function of terminal 42 (select input binary 4)**

(also refer to Section 10.1, Sheet 6, 10.3 and alarm for P761)

Number(s) of the binary input function(s), assigned to terminal 42.

from SW2.00

This terminal can have up to 3 different assigned binary input functions.This allows up to 3 functions to be simultaneously switched using one control signal

- 0 No function
- 1 Reserved
- 2 Binary input function 2
- x Refer to a list of the binary input functions, Section 10.3

Factory setting: 0 Value range: 0 to 68 (binary input function)

Access: 20 Change: off-line Index ii = 00 to 02 (from SW2.00)

**P765.ii Selecting the function of terminal 43 (select input binary 5)**

(also refer to Section 10.1, Sheet 6, 10.3, alarm for P761)

Number(s) of the binary input function(s), assigned to terminal 43.

from SW2.00

This terminal can have up to 3 different assigned binary input functions.This allows up to 3 functions to be simultaneously switched using one control signal

- 0 No function
- 1 Reserved
- 2 Binary input function 2
- x Refer to a list of the binary input functions, Section 10.3

Factory setting: 0 Value range: 0 to 68 (binary input function)

Access: 20 Change: off-line Index ii = 00 to 02 (from SW2.00)

**P766 Selecting the function of terminal 36 (select input binary 6)**

(also refer to Section 10.1, Sheet 6, 10.3, alarm for P761)

Number of the binary input function, which is assigned to terminal 36.

- 0 No function
- 1 Reserved
- 2 Binary input function 2
- x Refer to a list of the binary input functions, Section 10.3
- 5 Fault acknowledgement

Factory setting: 5 Value range: 0 to 68 (binary input function)

Access: 20 Change: off-line

**P767 Delay of the external fault**

(also refer to Section 10.3.53)

If a binary select input or a bit of the STWF is assigned the "external fault" function (= binary input function 53), then a fault message is only activated at the converter, if the appropriate input is set to LOW for at least the time set at P767.

Factory setting: 0ms                      Value range (steps): 0 to 10000ms (1ms)

Access: 20                                  Change: on-line

**P769 Control word for switch-on, shutdown and crawl****from SW2.00**

(also refer to Sections 10.3.2, 10.3.15 and 10.3.90)

- 0 An input, assigned the function "switch-on" or "crawl" responds to  
Signal level : H signal ... "switch-on" or "crawl"  
                  L signal ... "shutdown"
- 1 An input, assigned the function "switch-on" or "crawl" responds as follows to an edge:  
Positive edge at a "switch-on" input (terminal 37 or bit 0 of control word STW), or an  
input, parameterized as "crawl" (BEF15, BEF16)  
(select terminal or bit of the freely-definable control word STWF) results in "switch-on"  
or "crawl",  
Negative edge at an input, parameterized as "shutdown button (low active)" (BEF2)  
(select terminal or bit of the freely-definable control word STWF) results in "shutdown".

Factory setting: 0                          Value range: 0 to 1

Access: 20                                  Change: off-line

**Binary outputs****P770 Control word for the binary select outputs**

(also refer to Section 10.1, Sheet 4)

- xxx0 Binary select output 1 (terminal 46) is not inverted  
xxx1 Binary select output 1 (terminal 46) is inverted
- xx0x Binary select output 2 (terminal 48) is not inverted  
xx1x Binary select output 2 (terminal 48) is inverted
- x0xx Binary select output 3 (terminal 50) is not inverted  
x1xx Binary select output 3 (terminal 50) is inverted
- 0xxx Binary select output 4 (terminal 52) is not inverted  
1xxx Binary select output 4 (terminal 52) is inverted

Factory setting: 0000                      Value range (steps): 0000 to 1111 (1 hex)

Access: 20                                  Change: off-line

**P771 Selecting the function of terminal 46 (select output, binary 1)**

(also refer to Section 10.1, Sheet 4, 10.3.61 and 10.4)

Number of the binary output function assigned to terminal 46.

- 0 log. "0"
- 1 log. "1"
- 2 log. "0" or can be set via binary select input (refer to binary input function 61)
- 3 Fault      H: No fault  
                  L: Fault
- x Refer to the list of binary output functions, Section 10.4

Factory setting: 3                      Value range: 0 to 35 (binary output function)

Access: 20                              Change: on-line

**P772 Selecting the function of terminal 48 (select output, binary 2)**

(also refer to Section 10.1, Sheet 4, 10.3.62 and 10.4)

Number of the binary output function assigned to terminal 48.

- x Refer to the list of binary output functions, Section 10.4

Factory setting: 0                      Value range: 0 to 35 (binary output function)

Access: 20                              Change: on-line

**P773 Selecting the function of terminal 50 (select output, binary 3)**

(also refer to Section 10.1, Sheet 4, 10.3.63 and 10.4)

Number of the binary output function assigned to terminal 50.

- x Refer to the list of binary output functions, Section 10.4

Factory setting: 0                      Value range: 0 to 35 (binary output function)

Access: 20                              Change: on-line

**P774 Selecting the function of terminal 52 (select output, binary 4)**

(also refer to Section 10.1, Sheet 4, 10.3.64 and 10.4)

Number of the binary output function assigned to terminal 52.

- x Refer to the list of binary output functions, Section 10.4

Factory setting: 0                      Value range: 0 to 35 (binary output function)

Access: 20                              Change: on-line

**P775 Delay of binary select output 1 (terminal 46)**

(also refer to Section 10.1, Sheet 4)

The logical signal level at a binary select output only changes, if the internal signal level remains constant for the selected delay time (internal level changes, which are shorter than this time, are not switched-through to the output).

Factory setting: 0ms                      Value range (steps): 0 to 10000ms (1ms)

Access: 20                              Change: on-line

**P776 Delay of binary select output 2 (terminal 48)**

(also refer to Section 10.1, Sheet 4 and 10.4)

The logical signal level at a binary select output only changes, if the internal signal level remains constant for the selected delay time (internal level changes, which are shorter than this time, are not switched-through to the output).

Factory setting: 0ms                      Value range (steps): 0 to 10000ms (1ms)

Access: 20                                  Change: on-line

**P777 Delay of binary select output 3 (terminal 50)**

(also refer to Section 10.1, Sheet 4 and 10.4)

The logical signal level at a binary select output only changes, if the internal signal level remains constant for the selected delay time (internal level changes, which are shorter than this time, are not switched-through to the output).

Factory setting: 0ms                      Value range (steps): 0 to 10000ms (1ms)

Access: 20                                  Change: on-line

**P778 Delay of binary select output 4 (terminal 52)**

(also refer to Section 10.1, Sheet 4 and 10.4)

The logical signal level at a binary select output only changes, if the internal signal level remains constant for the selected delay time (internal level changes, which are shorter than this time, are not switched-through to the output).

Factory setting: 0ms                      Value range (steps): 0 to 10000ms (1ms)

Access: 20                                  Change: on-line

**Configuration of the basic converter serial interfaces****P780 Protocol selection for G-SST0 (RS485) at X500**

(Description of the individual function, refer to Section 10.7)

|      |  |             |
|------|--|-------------|
| xxx0 | No function  |             |
| xxx1 | Function can be selected via P051 (4-wire operation)(refer to P051 in Section 9.2) |             |
| xxx2 | USS protocol (2-wire operation) (refer to Section 10.7.3)                          | from SW1.10 |
| xxx3 | Free   |             |
| xxx4 | "Peer-to-peer" bus communication (2-wire operation) (refer to Section 10.7.4)      | from SW2.00 |
| xxx5 | "Peer-to-peer" communication (4-wire operation) (refer to Section 10.7.4)          | from SW1.10 |
| xxx6 | Free   |             |
| xxx7 | Free   |             |
| xxx8 | Free   |             |
| xxx9 | Diagnostics monitor (4-wire operation) (for factory-internal testing purposes)     |             |
| xx8x | 8 bit data frame ("8 data bits" or "7 data bits + parity bit")                     |             |
| xx9x | 9 bit data frame ("9 data bits" or "8 data bits + parity bit")                     |             |
| x0xx | No parity check and generation   |             |
| x1xx | Checking for even parity and sending a corresponding parity bit                    |             |

1xxx 1 stop bit  
2xxx 2 stop bit

## NOTE

A new interface setting (P780 and P783) is only realized, if P780 is changed and the parameter mode selected.

Thus, the following should be observed:

- 1) If P780 changes when setting an interface parameter, then it is sufficient, to first set P783 and then P780. The new setting is transferred by the subsequent changeover into the parameter mode.
- 2) If however, P780 remains the same, i.e. only the baud rate is changed via P783, then the re-configuration should be realized as follows: First change P780 (e.g. to xxx0), then set P783 and finally reset P780 to the required value. The new setting is transferred when the parameter mode is then selected.

Factory setting: 1180

Value range (steps): 1080 to 2199 (1 hex)

Access: 20

Change: off-line

### **P781**      **Number of PZD elements for G-SST0 (RS485) at X500**      **from SW1.10**

(also refer to Section 10.1, Sheet 5 and 10.7.3)

This parameter is only effective, if P780 = xxx2 (USS protocol).

- 0            No process data are expected in the USS protocol and none are sent
- 1 to 16    Number of process data words in the USS protocol (the same number for receive and send)  
The received PZD elements 1 to max. 16, are available at connectors K020 to K035 for internal "connection".  
The PZD elements 1 to max. 16, to be sent, are selected using parameters P784.00 to P784.15.

Factory setting: 0 word(s)

Value range: 0 to 16 word(s)

Access: 20

Change: off-line

### **P782**      **Number of PKW elements for G-SST0 (RS485) at X500**      **from SW1.10**

(also refer to Section 10.7.3)

This parameter is only effective, if P780 = xxx2 (USS protocol).

- 0 to 2      No PKW data are expected in the USS protocol, and none are sent.
- 3 to 127   Three PKW data words are expected in the USS protocol, and three PKW data words are sent (for transferring parameter values).

Factory setting: 0

Value range: 0 to 127

Access: 20

Change: off-line

**P783 Baud rate for G-SST0 (RS485) at X500**

(also refer to Section 10.7)

|    |             |
|----|-------------|
| 1  | 300 baud    |
| 2  | 600 baud    |
| 3  | 1200 baud   |
| 4  | 2400 baud   |
| 5  | 4800 baud   |
| 6  | 9600 baud   |
| 7  | 19200 baud  |
| 8  | 38400 baud  |
| 9  | 93750 baud  |
| 10 | 187500 baud |

Factory setting: 10                      Value range: 1 to 10

Access: 20                                  Change: off-line

Note:

Refer to the note under P780 regarding when a value change becomes effective.

**P784.ii Send PZD assignment for G-SST0 (RS485) at X500                      from SW1.10**

(also refer to Section 10.1, Sheet 5 and 10.7.3)

This parameter is only effective, if P780 = xxx2 (USS protocol), P780 = xxx4 (peer-to-peer bus communication) or P780 = xxx5 (peer-to-peer communication).

Process data to be sent are defined by specifying the appropriate connector numbers

P784.00      connector number of the 1st PZD word to be sent

P784.01      connector number of the 2nd PZD word to be sent

to

P784.15      connector number of the 16th PZD word to be sent

Factory setting: 0                      Value range: 0 to 399 (connector number)

Access: 20                                  Change: off-line                      Index ii = 00 to 15

**P786 Bus address for G-SST0 (RS485) at X500                      from SW1.10**

(also refer to Section 10.7.3)

This parameter is only effective if P780 = xxx2 (USS protocol).

Address, which can be addressed via the converter in the USS bus mode.

Factory setting: 0                      Value range: 0 to 30

Access: 20                                  Change: off-line

**P787 Telegram failure time for G-SST0 (RS485) at X500                      from SW1.10**

This parameter is only effective if P780 = xxx2 (USS protocol).

0              No time monitoring

1 to 32      Time, which can expire between the reception of 2 telegrams addressed for the converter before a fault signal is output.

Factory setting: 1                      Value range (steps): 0 to 32s (1s)

Access: 20                                  Change: off-line



**P788 Telegram failure time for "peer-to-peer" coupling from SW2.00**

(also refer to F015 and F025 in Section 8.2.2.2 and Section 10.7.4)

This parameter specifies the maximum permissible telegram failure time when selecting "peer-to-peer" protocol or "peer-to-peer" bus protocol for interface G-SST0 (P780 = xxx4 or xxx5) or for interface G-SST1 (P790 = xxx4 or xxx5).

If no valid telegram is received after this time has been exceeded, fault message F015 or F025 is issued.

40 to 10000ms telegram failure time monitoring for active "peer-to-peer" coupling.

The following minimum settings for P788 are recommended, as telegram transmission time is a function of the baud rate (refer to P780 and P790):

| Baud rate acc. to P780 and P790 | Recommended minimum value for P788 |
|---------------------------------|------------------------------------|
| 300 baud                        | 520ms                              |
| 600 baud                        | 260ms                              |
| 1200 baud                       | 140ms                              |
| 2400 baud                       | 80ms                               |
| ≥ 4800 baud                     | 40ms                               |

Note:

If the "automatic restart" function (P086 > 0) is selected for the communications partner, then the only parameterization which is practical is when P788 > P086 (of the communication partner).

Factory setting: 40ms

Value range (steps): 40 to 10000ms (1ms)

Access: 20

Change: off-line

**P790 Protocol selection for G-SST1 (RS232) at X501 (or RS485 at X502 on the A1618 supplementary board)**

(refer to Section 10.7 for a description of the individual functions)

|      |  |             |
|------|--|-------------|
| xxx0 | No function  |             |
| xxx1 | Function can be selected via P051 (for RS485 option: 4-wire operation) (refer to P051, in Section 9.2)             |             |
| xxx2 | USS protocol (for RS485 option: 2-wire operation) (ref. to Sect. 10.7.3)   | from SW1.10 |
| xxx3 | Free   |             |
| xxx4 | "Peer-to-peer" bus communication (only possible with the RS485 option, 2-wire operation) (refer to Section 10.7.4) | from SW2.00 |
| xxx5 | "Peer-to-peer" communication (for RS485 option: 4-wire operation) (refer to Section 10.7.4)                        | from SW1.10 |
| xxx6 | Free   |             |
| xxx7 | Free   |             |
| xxx8 | Free   |             |
| xxx9 | Diagnostics monitor (for RS485 option: 4-wire operation) (for factory-internal testing purposes)                   |             |
| xx8x | 8 bit data frame ("8 data bits" or "7 data bits + parity bit")   |             |
| xx9x | 9 bit data frame ("9 data bits" or "8 data bits + parity bit")   |             |
| x0xx | No parity check and generation   |             |
| x1xx | Checking for even parity and sending an appropriate parity bit   |             |

1xxx 1 stop bit  
2xxx 2 stop bits

**NOTE**

A new interface setting (P790 and P793) is only realized, if P780 is changed and the parameter mode selected.

Thus, the following should be observed:

- 1) If P790 changes when setting an interface parameter, then it is sufficient, to first set P793 and then P790. The new setting is transferred by the subsequent changeover into the parameter mode.
- 2) If however, P790 remains the same, i.e. only the baud rate is changed via P793, then the re-configuration should be realized as follows: First change P790 (e.g. to xxx0), then set P793 and finally reset P790 to the required value. The new setting is transferred when the parameter mode is then selected.

Factory setting: 1192                      Value range (steps): 1080 to 2199 (1 hex)  
Access: 20                                      Change: off-line

**P791      Number of PZD elements for G-SST1 (RS232) at X501**  
**(or RS485 at X502 on the A1618 supplementary board)                      from SW1.10**

(also refer to Section 10.1, Sheet 5 and 10.7.3)

This parameter is only effective, if P790 = xxx2 (USS protocol).

- 0            No process data is expected in the USS protocol and none is sent
- 1 to 16    Number of process data words in the USS protocol (the same number for receive and send)  
The received PZD elements 1 to max. 16 are available at connectors K036 to K051 for internal "connection".  
The PZD elements 1 to max. 16 to be sent, are selected using parameters P794.00 to P794.15.

Factory setting: 0 words                      Value range: 0 to 16 words  
Access: 20                                      Change: off-line

**P792      Number of PKW elements for G-SST1 (RS232) at X501**  
**(or RS485 at X502 on the A1618 supplementary board)                      from SW1.10**

(also refer to Section 10.7.3)

This parameter is only effective, if P790 = xxx2 (USS protocol).

- 0 to 2      No PKW data is expected in the USS protocol, and no is sent.
- 3 to 127    3 PKW data words are expected in the USS protocol, and 3 PKW data words are sent (for transferring parameter values)

Factory setting: 3                              Value range: 0 to 127  
Access: 20                                      Change: off-line

**P793 Baud rate for G-SST1 (RS232) at X501  
(or RS485 at X502 on the A1618 supplementary board)**

(also refer to Section 10.7)

|    |             |
|----|-------------|
| 1  | 300 baud    |
| 2  | 600 baud    |
| 3  | 1200 baud   |
| 4  | 2400 baud   |
| 5  | 4800 baud   |
| 6  | 9600 baud   |
| 7  | 19200 baud  |
| 8  | 38400 baud  |
| 9  | 93750 baud  |
| 10 | 187500 baud |

Factory setting: 6                      Value range: 1 to 10

Access: 20                              Change: off-line

Note:

Refer to the note under P790 regarding when a value change becomes effective.

**P794.ii Send PZD assignment for G-SST1 (RS232) at X501  
(or RS485 at X502 on the A1618 supplementary board)                      from SW1.10**

(also refer to Section 10.1, Sheet 5 and 10.7.3)

This parameter is only effective, if P790 = xxx2 (USS protocol) or P790 = xxx5 (peer-to-peer communication).

The process data to be sent are defined by specifying the appropriate connector numbers

|         |  |
|---------|--|
| P794.00 | connector number of the 1st PZD word to be sent  |
| P794.01 | connector number of the 2nd PZD word to be sent  |
| to      |  |
| P794.15 | connector number of the 16th PZD word to be sent |

Factory setting: 0                      Value range: 0 to 399 (connector number)

Access: 20                              Change: off-line                      Index ii = 00 to 15

**P796 Bus address for G-SST1 (RS232) at X501  
(or RS485 at X502 on the A1618 supplementary board)                      from SW1.10**

(also refer to Section 10.7.3)

This parameter is only effective, if P790 = xxx2 (USS protocol).

Address, which can be addressed via the converter in the USS bus mode.

Factory setting: 0                      Value range: 0 to 30

Access: 20                              Change: off-line

**P797 Telegram failure time for G-SST1 (RS232) at X501  
(or RS485 at X502 on the A1618 supplementary board) from SW1.10**

(also refer to Section 10.7.3)

This parameter is only effective, if P790 = xxx2 (USS protocol).

0 No time monitoring

1 to 32 Time, which can expire between the reception of two telegrams addressed to the converter before an error message is issued.

Factory setting: 0 Value range (steps): 0 to 32s (1s)

Access: 20 Change: off-line

**P798 Control word for G-SST1 (RS232) at X501 (handshake mode)**

(also refer to Section 10.7.1)

This parameter is only effective for P790 = xxx1 and P790 = xxx9.

**1 Software handshake (XON / XOFF handshake)**

Received character:

XOFF (13H): it is not permissible that the SIMOREG converter sends  
XON (11H): the SIMOREG converter can send  
other character: is ignored

**2 Hardware handshake**

CTS input (X501 pin 8): Clear To Send  
Low signal (= + 10V): The SIMOREG converter can send  
High signal (= - 10V): It is not permissible that the SIMOREG converter sends

RTS output (X501 pin 7): Request To Send  
Low signal (= + 10V): The SIMOREG converter is ready to receive  
High signal (= - 10V): The SIMOREG converter is not ready to receive

Caution:

The CTS signal must be switched to high (-10 V) by the receiving device (printer, PC, etc.), at the latest when the minimum reserve of its receive buffer has been reached (refer to the following table), as otherwise the buffer could overflow and data could be lost (printer omits characters).

| Baud rate   | Required buffer reserve in the receiving device |
|-------------|---|
| 300 to 4800 | 1 byte  |
| 9600        | 2 byte  |
| 19200       | 3 byte  |
| 38400       | 5 byte  |
| 93750       | 11 byte   |
| 187500      | 20 byte   |

Factory setting: 1 Value range: 1 to 2

Access: 20 Change: off-line

**NOTE**

Hardware handshake is not possible when using supplementary board A1618. Parameter P798 must be set to 1!



## Disabling fault and parameter change reports

### P850.ii Disabling monitoring functions



**WARNING**

If monitoring functions are disabled, and an actual fault does occur, this can result in a potentially dangerous situation for personnel and can in turn result in significant material damage.

The numbers of all monitoring functions, which are to be disabled, are entered in this parameter. The fault number sequence can be random. 0 should be written into indices of parameter P850 which are not used.

Factory setting:

|                        |  |
|------------------------|--|
| P850.00 = 7            | (Overvoltage)  |
| P850.01 = 28           | (Short-circuit at the binary outputs)                |
| P850.02 = 30           | (Controller monitoring, technology controller)       |
| P850.03 = 31           | (Controller monitoring, speed controller)            |
| P850.04 = 32           | (Controller monitoring, armature current controller) |
| P850.05 = 33           | (Controller monitoring, EMF controller)              |
| P850.06 = 34           | (Controller monitoring, field current controller)    |
| P850.07 = 35           | (Drive stalled)                                      |
| P850.08 = 36           | (No armature current can flow)                       |
| P850.09 = 37           | (1 <sup>st</sup> motor monitoring has responded)     |
| P850.10 to P850.99 = 0 |  |

Value range: 0 to 127

Access: 30

Change: on-line

Index ii = 00 to 99

### P855 Control word for parameter change reports

from SW1.10

If a parameter value has been changed (operator control panel, parameter change task via G-SST0, G-SST1 or supplementary board), using a parameter change report, the changed parameter value is signaled to other nodes (USS nodes at G-SST0 or G-SST1). This signal output can be suppressed for each individual node.

Caution:

When changing the control word, parameter change report buffers can be deleted!

|     |  |
|-----|--|
| 000 | No parameter change reports sent                                   |
| xx1 | Parameter change reports via USS protocol to G-SST0 (X500)         |
| x1x | Parameter change reports via USS protocol to G-SST1 (X501 or X502) |
| 1xx | Reserved (parameter change reports via the dual port RAM)          |

Factory setting: 000

Value range (steps): 000 to 111 (1 hex)

Access: 30

Change: on-line

## Diagnostic aids

### Thyristor diagnostics

#### **P860 Control word for thyristor diagnostics**

(also refer to Section 8.2.2.5)

- 0 Thyristor check disabled
- 1 Thyristors are only checked once after the first SWITCH-ON or INCHING and after the electronics supply voltage has been switched-on.
- 2 Thyristors are checked at each SWITCH-ON or INCHING.
- 3 Thyristors are checked at the next SWITCH-ON or INCHING. Parameter P860 is set to 0 if no faults occur.

Note:

- When using the binary input function "enable a torque direction for torque direction change with a parallel drive" (BEF60) (refer to Section 10.3.60) and
- When feeding very high inductances (e.g. when supplying the field from the armature terminals, supplying hoisting magnets etc.), the thyristor check cannot be used (set P860 = 0)

Non-identification of thyristors which cannot be fired:

For power sections connected in parallel (parallel SITOR sets, also refer to P074), it can occur, that in spite of the fact that the thyristor check is activated (P860 = 1, 2 or 3), that a thyristor which cannot be fired is still not identified (in the basic converter or in the parallel SITOR set). In this case, the thyristors in parallel to the non-conductive thyristor conducts the total current.

Factory setting: 0                      Value range: 0 to 3

Access: 20                              Change: off-line

### Settings for diagnostic recording

#### **P861.ii Numbers of the connectors for diagnostic recording**

This parameter is used to select connectors which are to be recorded for diagnostics (also refer to Section 10.10).

- P861.00 Reserved
- P861.01 Number of the 1st connector (value of this connector is displayed at P041)
- P861.02 Number of the 2nd connector (value of this connector is displayed at P042)
- P861.03 Number of the 3rd connector
- P861.04 Number of the 4th connector
- P861.05 Number of the 5th connector
- P861.06 Number of the 6th connector
- P861.07 Number of the 7th connector
- P861.08 Number of the 8th connector

Factory setting: 0                      Value range: 0 to 399 (connector number)

Access: 10                              Change: on-line                      Index ii = 00 to 08

**P862 Connector number in the trigger condition**

Number of the connector whose value triggers the T command (also refer to Section 10.10).

Factory setting: 0                      Value range: 0 to 399 (connector number)

Access: 20                              Change: on-line

**P863 Trigger condition for diagnostics recording**

Trigger condition type for the T command (also refer to Section 10.10).

- 0 Trigger condition "<"
- 1 Trigger condition "=" (can only be conditionally used, as it is improbable, that the value of connector according to P862 has precisely the same percentage, set at P864.)
- 2 Trigger condition ">"
- 3 Triggering when a fault occurs (P862 and P864 are in this case invalid)

Factory setting: 0                      Value range: 0 to 3

Access: 20                              Change: on-line

**P864 Percentage in the trigger condition for diagnostic recording**

Threshold for the connector value, defined with parameter P862, where the T command is triggered (also refer to Section 10.10).

Factory setting: 0.0%                  Value range (steps): -200.0 to 199.9% (0.1%)

Access: 20                              Change: on-line

**P865 Sampling interval for diagnostics trace**

This parameter defines the duration of a record cycle (specifies, whether the diagnostic recording of the 8 connectors, selected using P861.ii, is to be realized in each (1), each 2nd (2), or each 99th (99) firing pulse cycle (also refer to Section 10.10).  
(One firing pulse cycle period is 1/6 of the supply period)

Factory setting: 1                      Value range: 1 to 99

Access: 20                              Change: on-line

**P866 Trigger delay for diagnostic recording**

Number of record cycles where the diagnostics recording continues to run after a trigger condition has occurred, in order to record "post events" after the trigger instant (also refer to Section 10.10).

Factory setting: 1                      Value range: 1 to 999

Access: 20                              Change: on-line



**P867 Control bit for diagnostics recording**

(also refer to Section 10.10)

The "trigger" is activated with P867 = 1

- 0 No recording, or recording was already completed
- 1 Trace until the trigger time instant and trigger delay: The 8 connectors (selecting using P861.ii) are recorded (using P865) in the selected trace cycle until the trigger condition (according to P862 to P864) is fulfilled and until the following bit delay has expired (according to P866). The trace is then stopped and P867 is set to 0.

Factory setting: 0                      Value range: 0 or 1

Access: 20                              Change: on-line

**P868 Output speed for analog output of the trace buffer contents**

**from SW2.00**

The values of the first four traced connectors can be output via the analog select outputs 1 to 4 as voltages between -10 V and +10 V (refer to Section 10.1, Sheet 3 for additional normalization of the quantities).

(300/P868) values per second are output (also refer to Section 10.10.3 "Output of the trace buffer contents via the analog select outputs").

Factory setting: 1                      Value range: 1 to 300

Access: 20                              Change: on-line

**P869 Output mode for the analog output of the trace buffer contents**

**from SW2.00**

(also refer to Section 10.10.3 "Output of the trace buffer contents via the analog select outputs").

- 1 Single output (e.g. for plotters)
- 2 Continuous output (e.g. for output using a non-storage oscilloscope, whereby the output is immediately repeated after the last recorded value has been output)

Factory setting: 1                      Value range: 1 to 2

Access: 20                              Change: on-line

**P870 Trace parameter output mode**

**from SW2.00**

This parameter specifies how the contents of parameters P841.ii to P848.ii and P883.ii are to be displayed or output (also refer to "Reading-out the contents of the trace buffer via the operator control panel" Section 10.10.2).

- 0 Hexadecimal output
- 1 Percentage output (100.00% corresponds to 16384)

Factory setting: 1                      Value range: 0 to 1

Access: 20                              Change: on-line

## Number of write accesses to the permanent (EEPROM) memory

### **P871** Number of write accesses to the permanent (EEPROM) memory

Display, as to how often individual bytes have been written into the EEPROM.

(also refer to P053)

Factory setting: 0

Value range: 0 to 65535

Access: Can only be read

### **CAUTION**

Only a limited number of EEPROM write accesses are guaranteed within its lifetime (10,000).

Thus, frequent parameter value changes via the interfaces (serial basic converter interfaces or cyclic parameter value changes via supplementary board) should, if possible only be realized in the RAM, and not in the EEPROM.

The "change parameter value (and not store in the EEPROM)" task is available for parameter changes via the interface (if the value is only changed in the RAM, the thus changed values are lost when the electronics power supply is switched-off).

### **P872** Number of page-write accesses to the EEPROM

This display indicates how often non-volatile process data were written into the EEPROM when the electronics power supply was switched-out or during supply dips/interruptions (also refer to P053).

Factory setting: 0

Value range: 0 to 65535

Access: Can only be read

## Fault memory

### **P880.ii** Fault memory

This parameter displays the numbers of the 4 faults which last occurred (value "0" means "no fault").

00 Number of the most current fault message

01 Number of the next to last fault message

02 Number of the third from last fault message

03 Number of the fourth from last fault message

(also refer to P053)

Factory setting: 0

Value range: 0 to 255

Access: Can only be read

Index ii = 00 to 03

## Reading-out memory locations

### P881 Segment number of the basic address

0 to 3

The contents of any memory location can be displayed using parameters P881 to P883.ii. P881 defines the segment number (5th digit) of the basic address, whose contents are displayed at P883.ii.

Example:

The contents of address 2468A<sub>hex</sub> are to be displayed => P881 = 2

Factory setting: 0                      Value range: 0 to 3

Access: 40                              Change: on-line

### P882 Segment offset of the basic address

0000 to FFFF

P882 defines the segment offset of the basic address, whose contents are to be displayed at P883. Using the index from P883, the data words following this basic address can be displayed.

Example:

Contents of address 2468A<sub>hex</sub> are to be displayed => P882 = 468A.

Caution:

Only even addresses are permitted, as the contents of a data word are displayed at P883.ii. When an uneven address is entered, the contents of the next lowest, even address are displayed (e.g. instead of 123<sub>hex</sub>, address 122<sub>hex</sub> is used).

Factory setting: 0                      Value range: 0000 to FFFF (1 hex)

Access: 40                              Change: on-line

### P883.ii Contents of the specified address

P883.00 displays the contents of the basic address, specified with P881 and P882. By increasing index value ii (0 to 99), the data words, following the basic address, can be displayed. When reading-out the values, parameter P870 can be used to define whether the display is a hexadecimal value or a percentage, referred to 16384.

Example:

P881 = 2 and P882 = 468A.

The contents of the following address 2468C<sub>hex</sub>, 2468E<sub>hex</sub>, 24690<sub>hex</sub>, etc., are displayed by increasing the index value, i.e. at P883.00 the contents of basic address 2468A<sub>hex</sub> are displayed, at P883.01 from 2468C<sub>hex</sub>, etc.

Caution:

When the maximum address 3FFFF<sub>hex</sub> is exceeded by increasing the index value of P883, the addresses from 00000<sub>hex</sub> are re-displayed.

Value range: 0000 to FFFF (hex)

Access: Can only be read              Index ii = 00 to 99

## Settings for internal converter adjustments

### P884 Offset adjustment for the field current actual value channel

$$\text{Parameter value} = \frac{18000}{f_0 \text{ [kHz]}}$$

whereby  $f_0$  is that frequency, at which the field current actual value 0% is generated. The nominal value 1.128 kHz corresponds to a parameter value of 15957.

P884 is automatically set during the optimization run for pre-control and current controller for armature and field (P051 = 25) or during automatic offset adjustment (P051 = 22).

Nominal value: 15957                      Value range: 12418 to 20000

Access: 20                                      Change: off-line

### P885 Offset adjustment for the main actual value channel (channel 1)

1 bit of the parameter value corresponds to approx. 0.012% of the nominal main actual value, if the nominal value of the input quantity lies within the voltages specified for terminals 101 to 103 (8 - 25V, 25 - 80V, 80 - 250V).

P885, together with P886, can be determined using the automatic offset adjustment (P51 = 22).

Nominal value: 0                              Value range: -1000 to 1000

Access: 20                                      Change: off-line

### P886 Offset adjustment for the main actual value channel (channel 2)

1 bit of the parameter value corresponds to approx. 0.012% of the nominal main actual value, if the nominal value of the input quantity lies within the voltages specified for terminals 101 to 103 (8 - 25V, 25 - 80V, 80 - 250V).

P885, together with P886, can be determined using the automatic offset adjustment (P51 = 22).

Nominal value: 0                              Value range: -1000 to 1000

Access: 20                                      Change: off-line

### P887.ii Correction of the measured time instants for the supply 0 crossovers

If a different armature current crest height occurs (in spite of a constant firing angle), the appropriate line supply phase can be corrected using P887.ii by shifting the reference time instant of the firing angle. Each parameter index (ii = 00 to 05) is assigned a supply phase (UV, UW, VW, VU, WU, WV).

When the parameter is increased by the value 1, this corresponds to a firing angle increase of  $1.777778 \mu\text{s}$  (0.032 degrees for 50 Hz supply frequency), and this results in a lower armature current crest for the associated supply phase.

P887 is automatically set during the optimization run for pre-control and current controller for the armature and field (P051 = 25).

Caution:

Unsymmetrical supplies also result in different armature current crest heights. However, the line unsymmetry can change.

Factory setting: 0                              Value range (steps): -100 to 100 \*  $1.77 \mu\text{s}$  ( $1 * 1.77 \mu\text{s}$ )

Access: 20                                      Change: on-line                              Index ii = 00 to 05

## 9.3 Global converter parameters

from SW1.10

The global converter parameters are defined and described in the Instruction Manual "Data transfer between SIMOVERT P or SIMOREG K converters and expansion boards".  
Order number 6DD1902-0GE0

## Supplementary information and deviations for SIMOREG K 6RA24

## Parameter presettings

| Parameter NO. | Designator  | Text display | Factory setting | Key parameter | Complexity (P052) |
|---------------|---|--------------|-----------------|---------------|-------------------|
| P900          | HW conf   | none         | 1               | 20            | 3                 |
| P901 *)       |   |              |                 |               |                   |
| P902          | Port1Sel  | none         | 1               | 20            | 3                 |
| P903          | Port1Lng  | none         | 2               | 20            | 3                 |
| P904          | Port1Adr  | none         | 0               | 20            | 3                 |
| P905          | Port1Bdr  | none         | 1               | 20            | 3                 |
| P906          | Port2Sel  | none         | 1               | 20            | 3                 |
| P907          | Port2Lng  | none         | 8               | 20            | 3                 |
| P908          | Port2Adr  | none         | 0               | 20            | 3                 |
| P909          | Port2BdR  | none         | 1               | 20            | 3                 |
| P910          | ParChEna  | none         | 4               | 20            | 3                 |
| P911          | PrDaEnab  | none         | 1               | 20            | 3                 |
| P912 *)       | For 6RA24 converters, the last 4 faults are displayed via P880.ii.  |              |                 |               |                   |
| P913 *)       | For 6RA24 converters the actual alarms are displayed via P049 and P050.   |              |                 |               |                   |
| P914 *)       | For 6RA24 converters, the last 4 faults are displayed via P880.ii.  |              |                 |               |                   |
| P915 *)       | For 6RA24 converters, the setpoints, entered via interface SST1 of the supplementary board, are "connected through" via K052 to K067 (also refer to Section 10.1, Sheet 5). |              |                 |               |                   |
| P916.ii       | Port1TDat   | none         | 0               | 20            | 3                 |
| P917 *)       |   |              |                 |               |                   |
| P918 *)       |   |              |                 |               |                   |
| P919 *)       |   |              |                 |               |                   |
| P920 *)       |   |              |                 |               |                   |
| P924          | PrtPDNo   | none         | 0               | 20            | 3                 |
| P925          | Prt1PENo  | none         | 0               | 20            | 3                 |
| P926          | Prt1MoTm  | none         | 1               | 20            | 3                 |
| P927          | Prt2PDNo  | none         | 0               | 20            | 3                 |
| P928          | Prt2PENo  | none         | 0               | 20            | 3                 |
| P929          | Prt2MoTm  | none         | 1               | 20            | 3                 |
| P930          | SDRminTm  | none         | 1               | 20            | 3                 |
| P931          | SlotTime  | none         | 1               | 20            | 3                 |
| P932          | AutRefTm  | none         | 0               | 20            | 3                 |
| P933 *)       |   |              |                 |               |                   |
| P970 *)       | For 6RA24 converters, the setpoints, entered via interface SST2 of the supplementary board, are "connected through" via K068 to K083 (also refer to Section 10.1, Sheet 5). |              |                 |               |                   |
| P971.ii       | Prt2TDat  | none         | 0               | 20            | 3                 |

\*) not implemented for 6RA24 converters

**NOTE**

After local parameters have been set or changed, to ensure perfect communications, the electronics power supply should be switched-off and on again.

**Deviations for the global converter parameters****P901 Test mode SST1/2**

Not implemented.

**P910 PKW parameter change rights**

For 6RA24 converters, P910 only defines whether the technology parameters (PT001 to PT999) can be changed. At the basic converter, all interfaces always have PKW parameter change rights, i.e., basic converter parameters can be changed from every interface. However, to change parameters of the technology board, the appropriate change rights must be selected.

- |   |  |             |
|---|--|-------------|
| 1 | G-BF (basic converter operator control panel) can change PT parameters | from SW2.00 |
| 2 | Reserved   |             |
| 3 | PT (technology board) can change PT parameters                         | from SW2.00 |
| 4 | SST1 (interface 1 on the interface board) can change PT parameters     |             |
| 5 | SST2 (interface 2 on the interface board) can change PT parameters     |             |

Factory setting: 1                      Value range: 1 to 5

Access: 20                                Change: on-line

**P911 PZD control (process data control)**

For 6RA24 converters, a differentiation is only made between local PZD (PZD via continuous signals at the basic converter terminals: Settings 1, 2 or 3), and PZD from an expansion board (technology- or interface board); settings 4 or 5). As soon as the PZD is missing for approximately 150% of the time set at P926 or P929, an alarm (setting 4) or a fault (setting 5) is displayed.

Caution:

For "local control" (setting 1 to 3), parameters P926 and P929 must be set to 0 to prevent the PZD failure monitoring responding (disabled monitoring functions, also refer to P926 and P929).

**P912 Fault sequence memory**

Not implemented (refer to basic converter parameter P880.ii).

**Processing the PT fault channel**

The basic converter processes the PT fault channel. PT fault 1 is read-out, and the fault number, entered in the fault channel (the PT fault numbers must be  $\geq 128$  and  $\leq 255$ ), is displayed as fault number at the basic converter. Fault handling (basic converter response) and fault reset are realized as for a basic converter fault.

If the technological process demands controlled shutdown, before the fault is entered in the fault message channel, the drive must be shutdown via the control word.

**P913 Alarm sequence memory**

Not implemented (refer to basic converter parameters P049 and P050)

**Processing the PT alarm channel**

The basic converter processes the PT alarm channel. If an alarm status (bits 0-10) in alarm words 1 to 7 is equal to 1, alarm W29 is initiated at the basic converter (group alarm PT).

**Processing the S alarm channel**

As for the PT alarm, however, alarm W30 (group alarm S) is activated.

**P914 Diagnostics memory**

Not implemented (refer to basic converter parameter P880.ii).

**P915 PZD assignment, SOW channel 1**

Not implemented. PZD assignment is realized via the connector numbers and the basic converter select parameters.

**P916.ii PZD assignment, ISW channel 1**

The set values are connector numbers.

**P917 to P919 Normalization parameters**

Not implemented.

**P920 Control word expansion**

Not implemented. The converter-specific, freely-definable control word STWF is used as control word expansion.

**P926 and P929 Telegram failure time for SST1 (P926) or SST2 (P929)**

The basic converter software monitors process data transfer. If there is no PZD data transfer for longer than approx. 1.5 x of the time set with P926 or P929, either an alarm W28 (P911 = 4) or fault F029 (P911 = 5) is activated. Process data failure monitoring is disabled with P926 = 0 or P929 = 0.

Caution:

The monitoring must be disabled for PZD channels which are not used.

**P933 Converter identification**

Not implemented.

**P970 PZD assignment, SOW channel 2**

Not implemented. PZD assignment is realized via the connector numbers and basic converter select parameters.

**P971.ii PZD assignment, ISW channel 2**

The set values are connector numbers.





## 10. Functions

### Notes regarding the function diagrams

A large proportion of the available converter functions, especially the open- and closed-loop control structures can be seen in the following function diagrams (Sheet 1 to Sheet 20).

#### Function blocks

The illustrated function blocks have been realized digitally (as so-called software modules), but the function diagrams can be "read" similar to circuit diagrams of analog equipment.

In addition to the function blocks for basic functions (ramp-function generator, speed controller, limiting functions, closed-loop current controller, closed-loop EMF controller etc.), there are also technology controllers and many freely-configurable function blocks such as adders, multipliers, dividers, inverters, changeover switch functions, limiting stages etc., which can be used to implement complex closed-loop control functions.

Further, the converter is equipped with a square-wave generator which can be parameterized (refer to Sheet 12 of the function diagrams and the "oscillation" and "forcing" functions, in Sections 10.3.12 and 10.12).

#### Ability to be structured

This converter can be parameterized and the function blocks can be freely structured. The ability to freely structure means that the connections between the individual function blocks can be selected per parameter.

#### Connectors

All important computation- and signal quantities, which are available within the software as digital values in memory locations, are available at "connectors". The quantities, accessible using connectors, correspond to the measuring points of an analog circuit, and are therefore designated with their own particular "connector number".

Examples:

- The analog signal injected at terminals XA.6 and XA.7 (analog select input 1) (differential input 0 to  $\pm 10V$  or 0 (4) to 20mA) is available after A/D conversion, normalization and filtering, as digital value at connector K005 ("analog select signal 1"). "P003" in the following diagram indicates that this signal, K005 ("analog select signal 1"), is displayed at parameter P003:

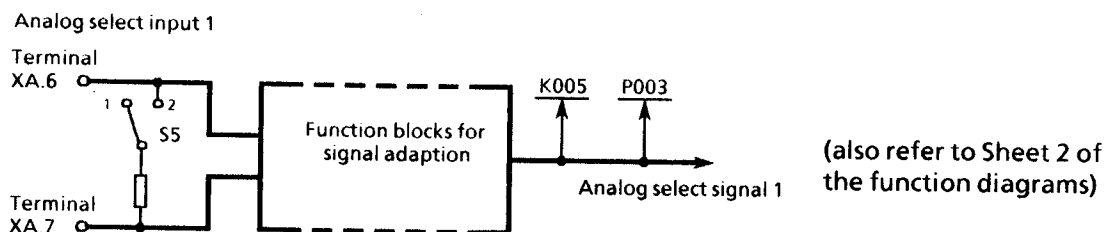

- The analog signal (0 to  $\pm 10V$  with respect to analog ground XA.9) injected at terminal XA.8 (analog select input 2) is available as digital value at connector K006 ("analog select signal 2") after A/D conversion, normalization and filtering, and is displayed at P004:

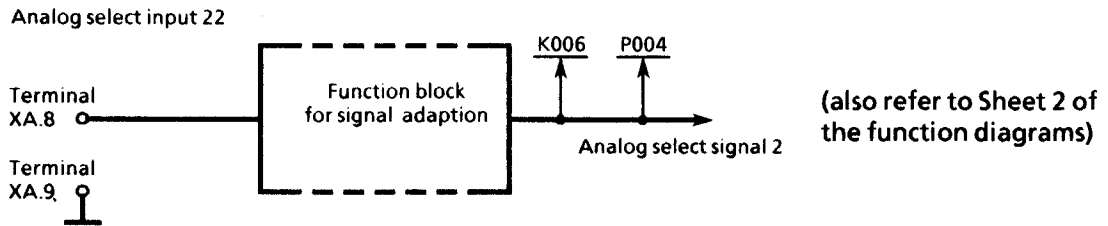

- Receive data of the basic converter interface G-SST0 (X500) is available at connectors K020 to K035:

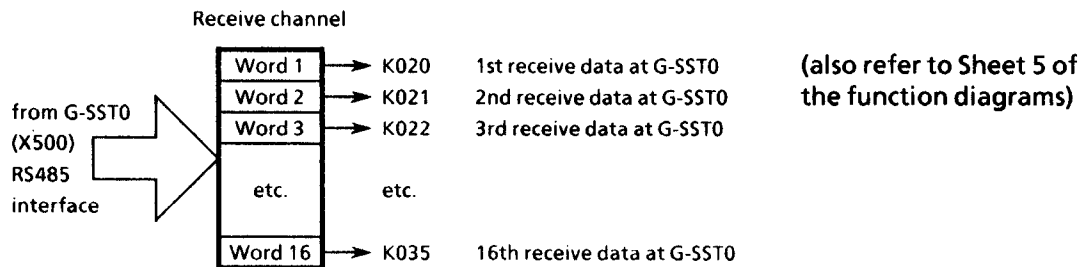

- In addition to the available signal quantities (e.g. main setpoint (K003), main actual value (K004), armature current actual value (K117), etc.), there are other digital values which are available at connectors (e.g. overall processor utilization (K390), code of the triggered thyristor pair (K105), etc.), but which are essentially used for diagnostics.
- K000 is a fixed value with a 0% signal level.
- K001 is a fixed value with 100% signal level.  
(connector number 1 can also have, for several parameters for selecting a negative limit, the significance of a fixed setpoint with -100% signal level).
- K002 is an exception, as connector number 2 is assigned several signal quantities. The signal quantity which is actually involved, is dependent to which selection parameter, connector number 2 is set (also refer below).

The list of available connectors is provided in Section 10.2.

The values, identified by their connector numbers, can be used within the converter, for example, to serve as setpoint for a controller, as input- or supplementary input value for a specific function block, or as variable value of a limiter.

The values of the individual connectors can also be displayed on the operator control panel, output via analog outputs, transmitted via the serial interfaces, and for diagnostics, recorded in the internal converter trace buffers (also refer to Section 10.10).

## Intervention points, connections

The inputs of software modules and function blocks are defined at "intervention points" via assigned selection parameters. To realize this, the connector of the required signal quantity, which should act as input quantity is entered at the parameter for the particular intervention point.

The intervention points are represented in the form of a selection switch in the function diagrams, whereby all available connectors (corresponding to the contact numbers), are connected to the individual switch contacts. The value (= connector number) of the assigned selection parameter controls the switch setting of this selection switch, and therefore defines which connector signal is available at the common switch contact.

Using this selection switch, controlled per parameter, connections can be established between the individual function blocks.

The following diagram is intended to clarify this using, as an example, analog select output 1:

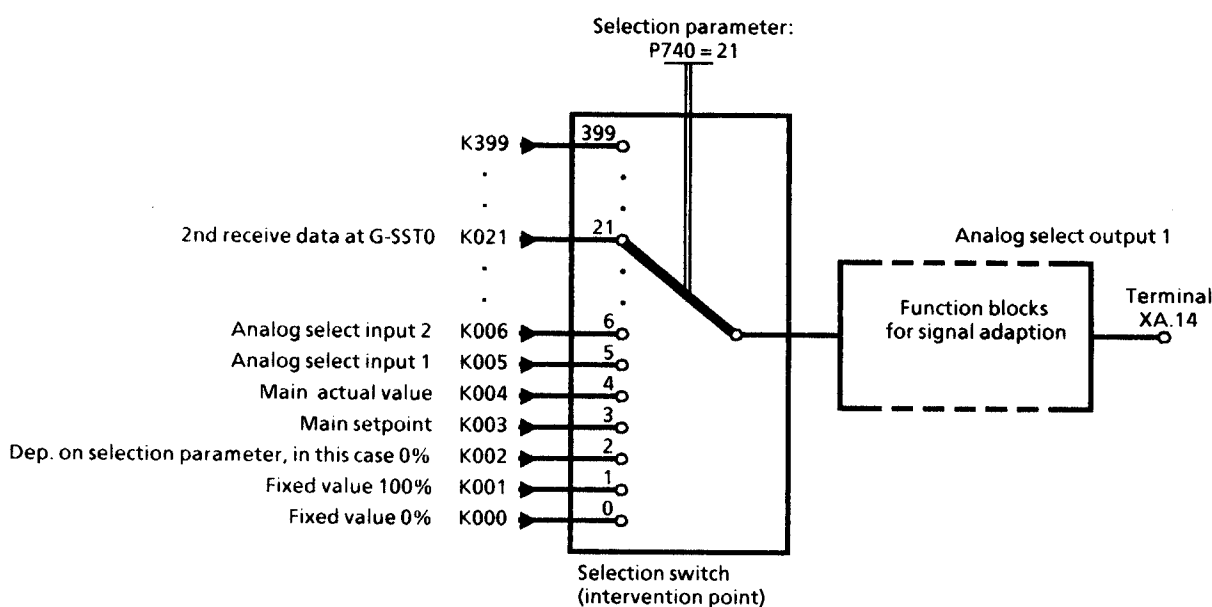

At the intervention point for analog select output 1, parameter P740 defines which signal quantity is output at terminal XA.14 ("analog select output 1") as analog voltage. All of the available connectors are listed to the left of the selection switch controlled by P740 - just like at all other selection switches.

For example, to output the 2nd data word of the process data (K021), received at the basic converter interface G-SST0 (X500), as analog voltage at analog select output 1, it is necessary to set parameter P740 = 21. This means, that a connection is established from word 2 of the receive channel from G-SST0 (K021), to analog select output 1.

The selection switches at the intervention points are represented as symbols in the function diagrams (according to the following example for analog select output 1):

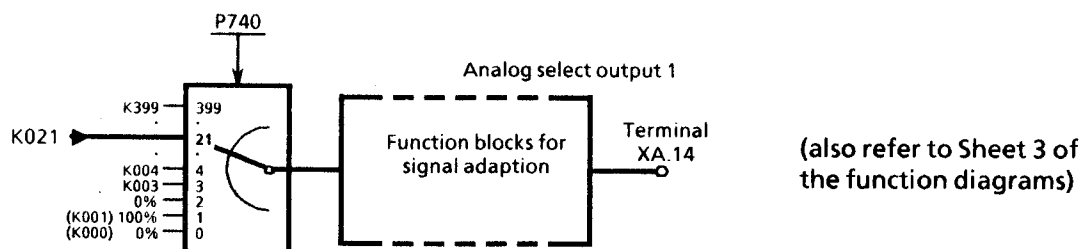

It should be noted, that contrary to all other switch- or selection parameter settings, setting 2 of a selection parameter-specific connector is switched-through, which generally corresponds to the converter factory setting.

- In the example above, for analog select output 1, for  $P740 = 2$ , fixed value 0% is switched-through and output.
- An additional example is the indexed selection parameter P628.ii in the following diagram and on Sheet 12 of the function diagrams:

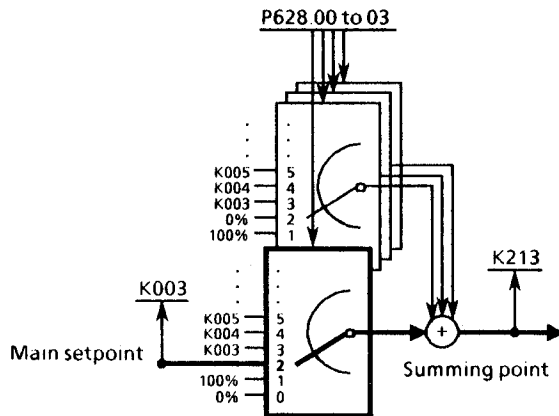

The sum of the quantities, defined using P628.00 to P628.03 is available at connector K213.

P628 defines the input of the ramp-function generator and the signal at connector K213. P628 is an indexed parameter, whereby all four signal quantities, selected with the individual indices of this parameter, are added at a summing point. The sum of the selected connectors is available at K213. The 4 selection switches are symbolically represented (staggered), for reasons of clarity.

All indices of P628 have the value 2 according to the factory setting. The setting  $P628.00 = 2$ , means, that the main setpoint, available at connector K003 (refer to Sheet 2 of the function diagrams) is switched through, and factory setting  $P628.01 = 2$ ,  $P628.02 = 2$  and  $P628.03 = 2$  means that fixed value 0% is added (i.e. no influence).

- For example, if the 2nd data word of the process data (which is available at K021, refer to Sheet 5 of the function diagrams) received at the basic converter interface G-SST0 (X500), and also the quantity of the analog select input 2 (which is available at K006, refer to Sheet 2 of the function diagrams), are to be added to the main setpoint (K003), in order to obtain K213, then the following parameter setting must be made:

- P628.00 = 2     The main setpoint (K003) is switched-through (factory setting)
- P628.01 = 21    The quantity of the second G-SST0 receive data (K021) is added
- P628.02 = 6     The quantity of analog select input 2 (K006) is added
- P628.03 = 2     Fixed value 0% (K001) is added (factory setting, no influence)

The connector, which is switched-through for setting 2 of a selection parameter, is dependent on the particular selection parameter.

- For example, the setting  $P622.00 = 2$  means that the output of the ramp-function generator (K190) is switched-through to the function block "setpoint limiting" and the setting  $P622.01$  to  $P622.03 = 2$  means that no additional value is added at the summing points (refer to the following diagram and Sheet 14 of the function diagrams).

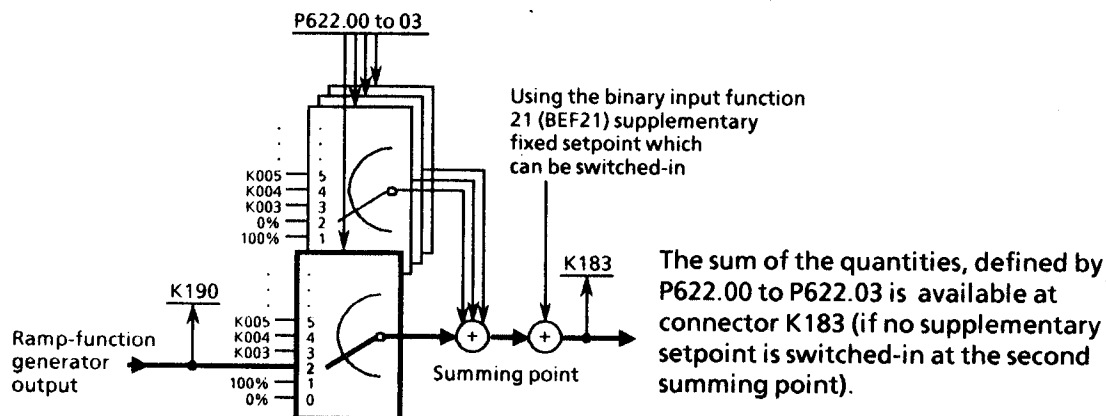

### Parameter intervention

In addition to the parameters, which are used to select a signal, and therefore the "connection" of the individual function blocks with one another (i.e. "structure") those parameters, which either define a mode or parameter value of a function, are indicated in the function diagrams.

Examples:

- P075 on Sheet 17 of the function diagrams defines the mode of operation of the I<sup>2</sup>t monitoring.
- P224 on Sheet 15 of the function diagrams defines the input polarity of the setpoint and actual value of the speed controller, and determines whether the speed controller P- or I component should be set to zero in order to obtain a pure I- or a pure P controller.
- The ten's location of P703 on Sheet 2 of the function diagrams defines whether the main setpoint, connected to terminals XA.4, XA.5, should be interpreted as voltage input ( $\pm 10V$ ), current input 4 to 20 mA, or as current input, 0 to 2 mA. The one's location of this parameter defines whether the analog main setpoint quantity at connector K003 is switched through as value with sign, absolute value, inverted value, or the inverted absolute value.
- P704 on Sheet 2 of the function diagrams defines the filter time constant of a PT1 element, with which the main setpoint should be filtered.
- P155 and P156 on Sheet 18 of the function diagrams defines the P gain and integral action time of the armature current controller.

**Binary input functions**

The intervention possibilities using "binary input functions" are indicated in the function diagrams.

The following example (refer to the following diagram), which uses the freely-configurable function blocks for changing the speed setpoint polarity, is intended to explain this. This example clearly shows how the individual function blocks (software modules), are "connected" with one another using the signal selection parameters.

**Task description:**

Using the "free changeover switch 1" which is controlled from the binary input function BEF65, and "free inverter 1" (also refer to Sheet 8 of the function diagrams), the output of the ramp-function generator setpoint limiting (K194), is to be connected through to the ramp-function generator input, either with the correct polarity, or inverted (also refer to Sheet 13 of the function diagrams). A high signal at terminal 39 is used as command to invert the signal. The following parameter settings are required:

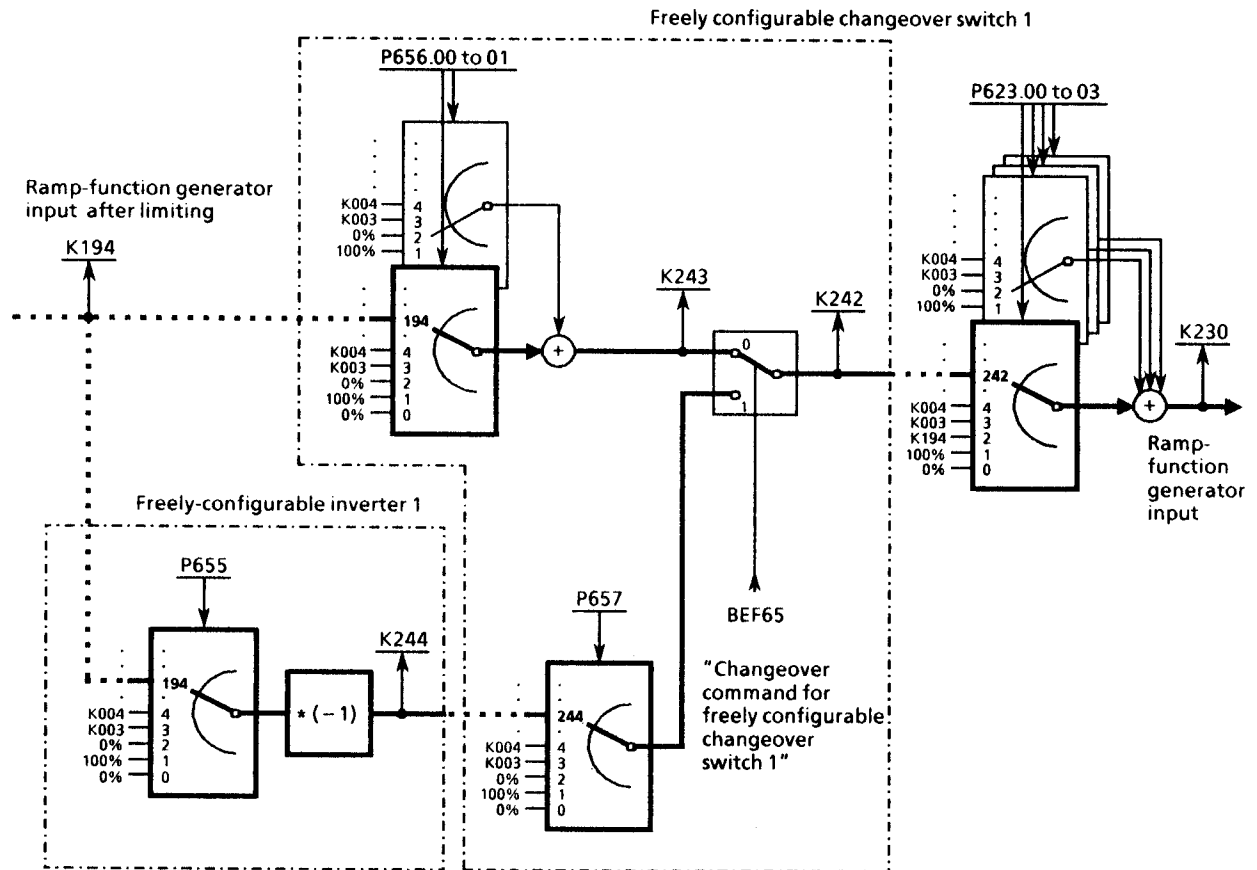

**Settings:**

- P656.00 = 194      K194 acts at the first input of the "freely-configurable changeover switch 1"
- P656.01 = 2      0 % is added at the summing point, therefore no effect (factory setting).
- P655 = 194      K194 acts at the input of the the "freely-configurable inverter 1".
- P657 = 244      The output of the "freely-configurable inverter 1" (K244) is connected at the 2nd input of "freely-configurable changeover switch 1".
- P623.00 = 242      The output of the "freely-configurable changeover switch 1" (K242) acts as setpoint in the speed setpoint chain. (the connection with connector K194, according to the factory setting (P623.00 = 2) is therefore disabled!).
- P623.01 to 03 = 2      0% is added at the summing point, therefore no effect (factory setting).

- BEF65: The changeover of the "freely-configurable changeover switch 1" is realized via binary input function BEF65.
- P761 = 65 Terminal 39 is assigned binary input function BEF65 ("changeover command for the freely-configurable changeover switch 1").
- L signal at terminal 39:  
The "freely-configurable changeover switch 1" is located at the position illustrated, i.e. connector K243 is switched-through, so that signal K194 at the ramp-function generator input acts as speed setpoint.
- H signal at terminal 39:  
The "freely-configurable changeover switch 1" is actuated, i.e., the signal (output of the "freely-configurable inverter 1" (K244)), selected using P657, is switched-through, so that the inverted signal (-K194) acts as speed setpoint at the ramp-function generator input.

The switch positions at the locations with intervention possibilities using "binary input functions" are shown in the function diagrams, corresponding to unused functions (for more detailed information, refer to Section 10.3).

Examples:

- The switch, assigned to the binary input function BEF43 ("switch-in analog input, main setpoint"), is closed for an unused function (refer to Sheet 2 of the function diagrams). However, if this binary input function is assigned a binary select terminal, the appropriate terminal must be activated so that the main setpoint can be switched-through at K003.
- The switch, assigned to binary input function BEF21 ("switch-in the supplementary setpoint before the speed controller"), is open if the function is not used (refer to Sheet 14 of the function diagrams).

#### Computation cycles, time delay

For functions associated with analog inputs, analog outputs, binary outputs and interfaces (illustrated on Sheets 2 to 5 of the function diagrams), and the function blocks associated with the technology controller, motorized potentiometer, setpoint generation, ramp-function generator and speed- and armature current controller (illustrated on Sheets 10 to 18 of the function diagrams), are called-up and calculated, in synchronism with the armature firing pulses (i.e. every 3.333 ms for a 50 Hz supply frequency).

The binary inputs (Sheet 6 of the function diagrams) are evaluated and the free function blocks processed (shown in Sheets 7 to 9 in the function diagrams) in every second armature firing pulse cycle (i.e. every 6.667 ms for a 50 Hz supply frequency).

The function blocks associated with the closed-loop EMF and field current control (shown in Sheets 19 and 20 of the function diagrams) are called-up and calculated in synchronism with the field firing pulses (i.e. every 10 ms at a 50 Hz supply frequency)

Parameterization is executed in an additional 20 ms computation cycle. The optimization run is also controlled in this cycle time.

When transferring parameter values via interfaces, it should be observed, that some of the transferred parameters must first be converted to this 20 ms cycle, before they can be used, for example, in the armature firing pulse cycle.

When "connecting" the freely-configurable function blocks, it should be observed, that the software modules are sequentially processed in a specific sequence:

Adder 1, multiplier/divider 1, general divider (refer to Sheet 7, upper row)

Inverter 1, changeover switch 1 (refer to Sheet 8, upper row)

Absolute value generator with filtering 1, limit value monitor 1 (refer to Sheet 9, upper row)

Adder 2, multiplier/divider 2, free characteristic (refer to Sheet 7, middle row)

Inverter 2, changeover switch 2, limiter (refer to Sheet 8, middle row)

Absolute value generator with filtering 2, limit value monitor 2 (refer to Sheet 9, lower row)

Adder 3 + dead range, multiplier/divider 3 (refer to Sheet 7, lower row)

Inverter 3, changeover switch 3 (refer to Sheet 8, lower row)

In order that no unnecessary signal delays occur, the specified sequence should be taken into account when sequencing these function blocks.

The processing sequence for all of the other modules of the appropriate computation cycle, essentially corresponds to the sequence that they are illustrated in the function diagrams.

#### **Parameter sets**

Although parameters in the range P100 to P599 are available four times (set 1 to 4), they are only indicated once in the function diagrams.

Note:

The individual indices of select parameters, which lie outside the range P100 to P59, should not be confused with the four parameter sets of the parameter range P100 to P599.

Please read the description and warning note in Section 10.3.33, .34, .35



10.1 Function diagrams  
Sheet 1 Overview

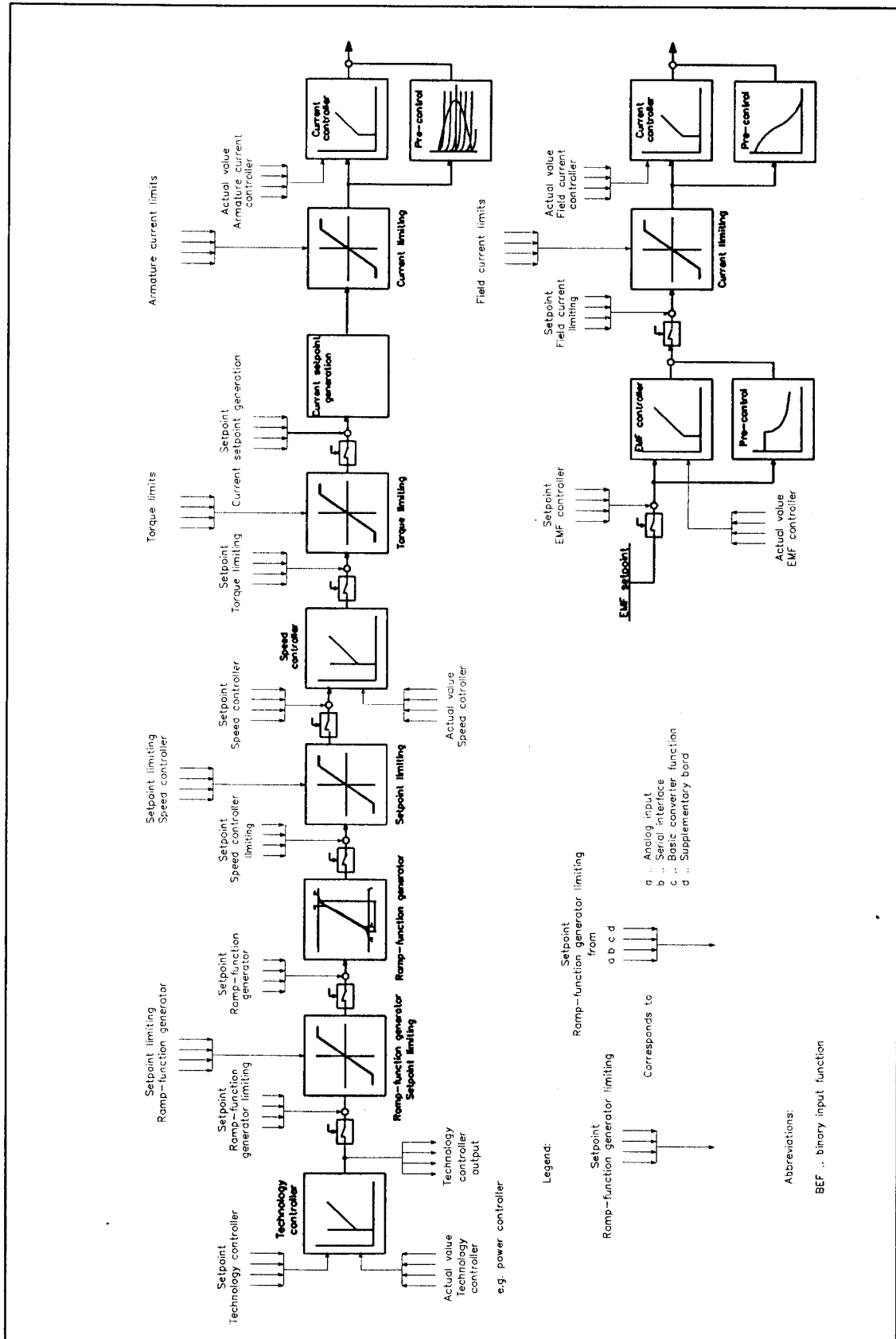

Sheet 2 Analog select inputs

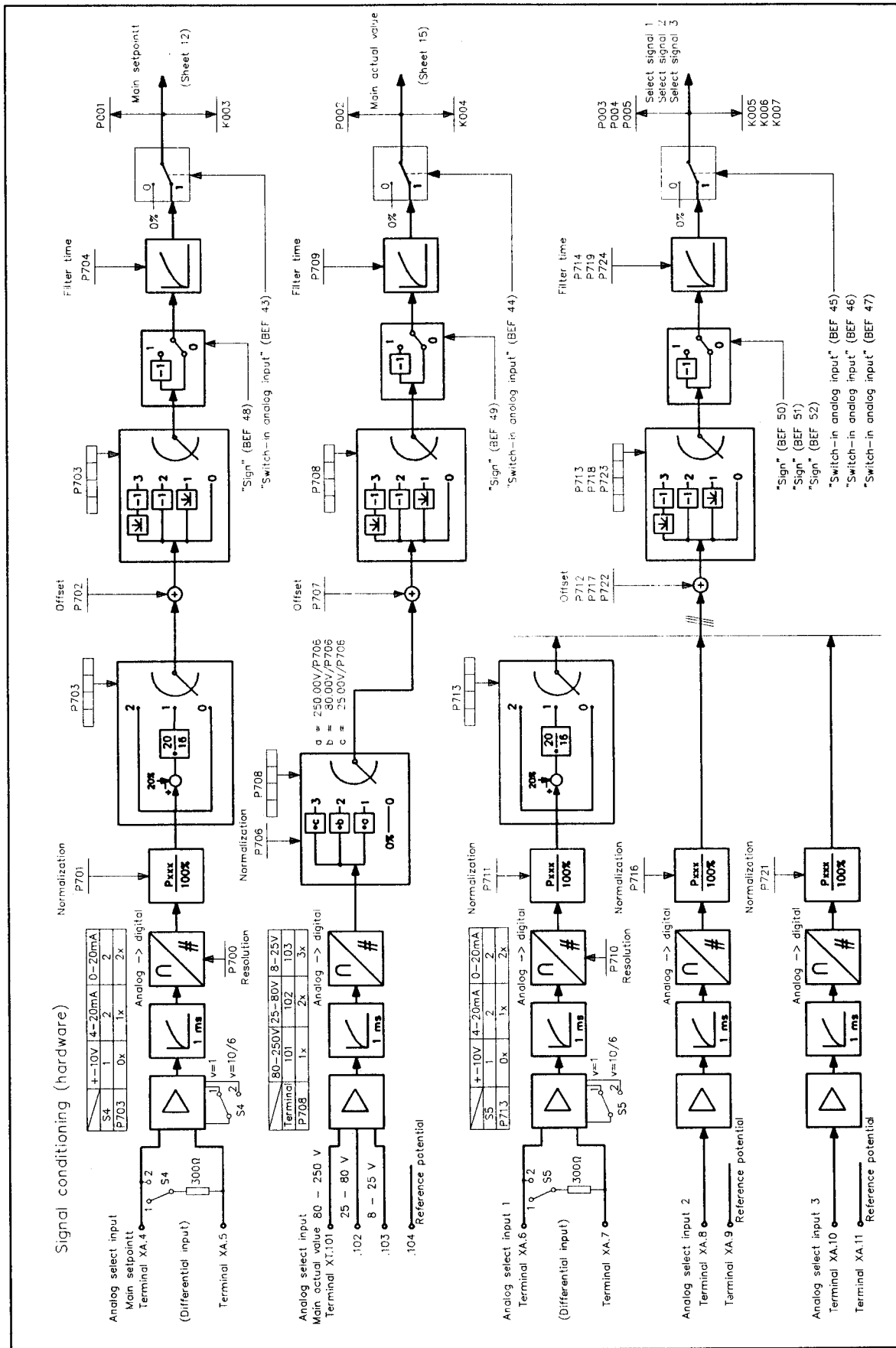

Sheet 3 Analog select outputs, select displays, current actual value display

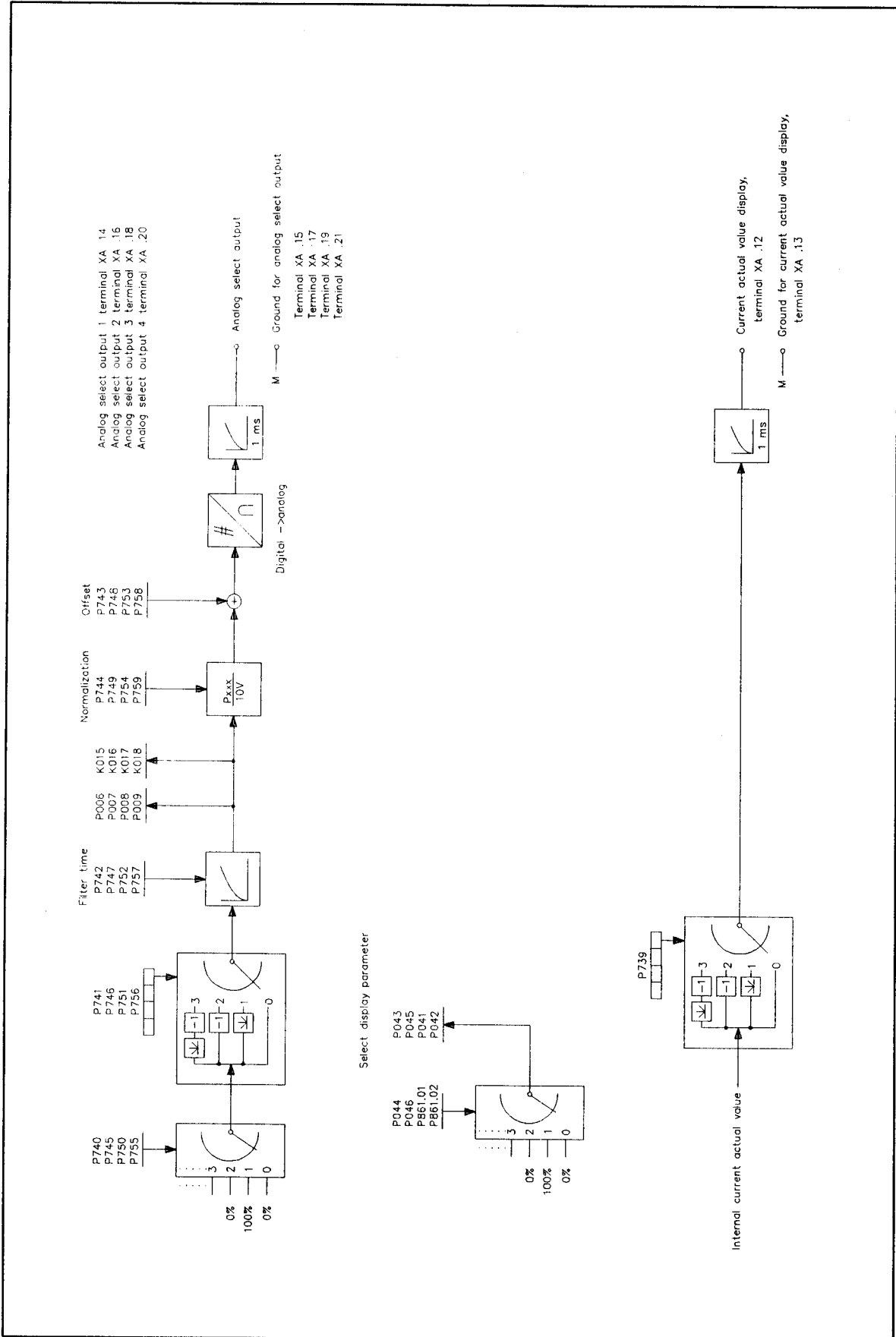

Sheet 4 Binary select outputs, status words

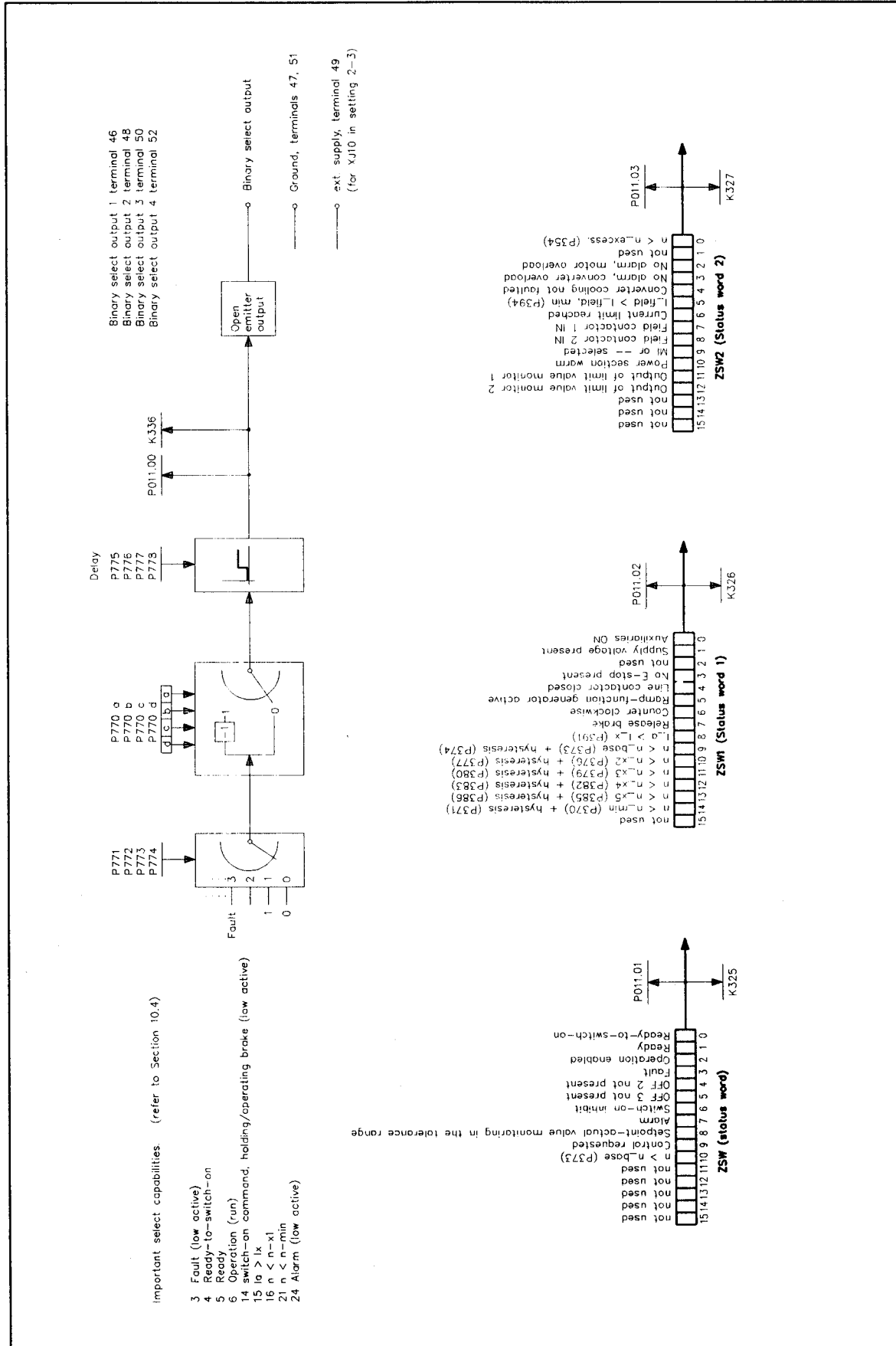

# Sheet 5 Connecting the process data from the serial interfaces and supplementary boards

## Interface to the PTI technology board or CS5 x interface board

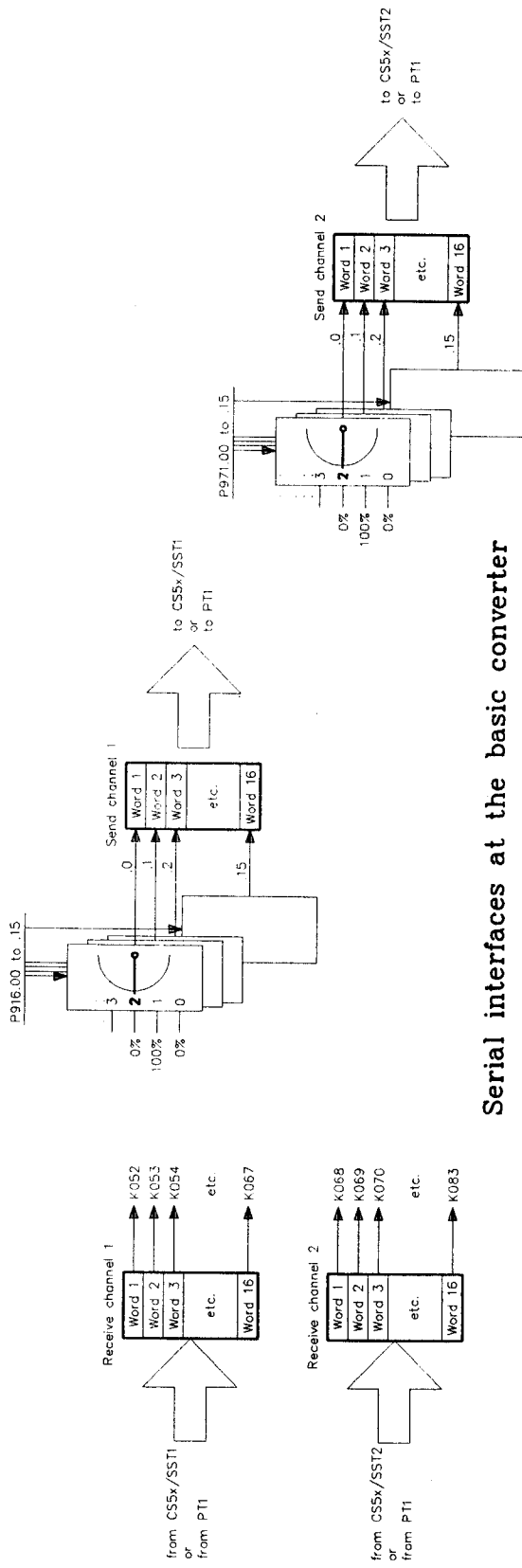

## Serial interfaces at the basic converter

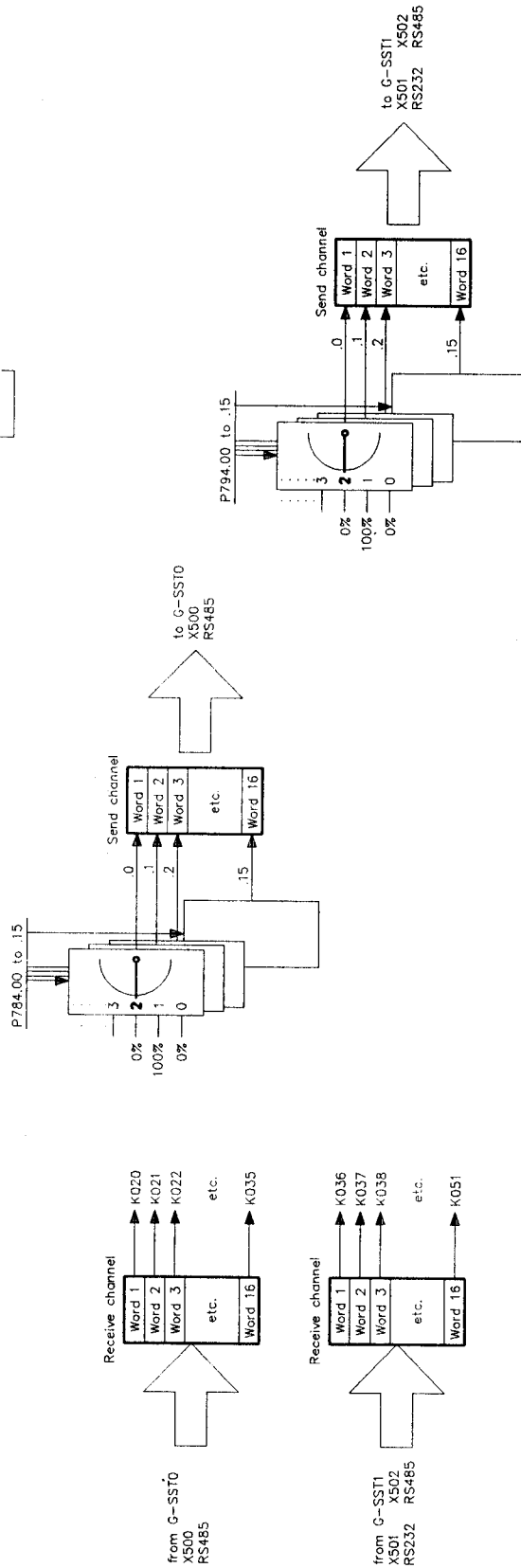

Sheet 6 Binary input functions (BEF)

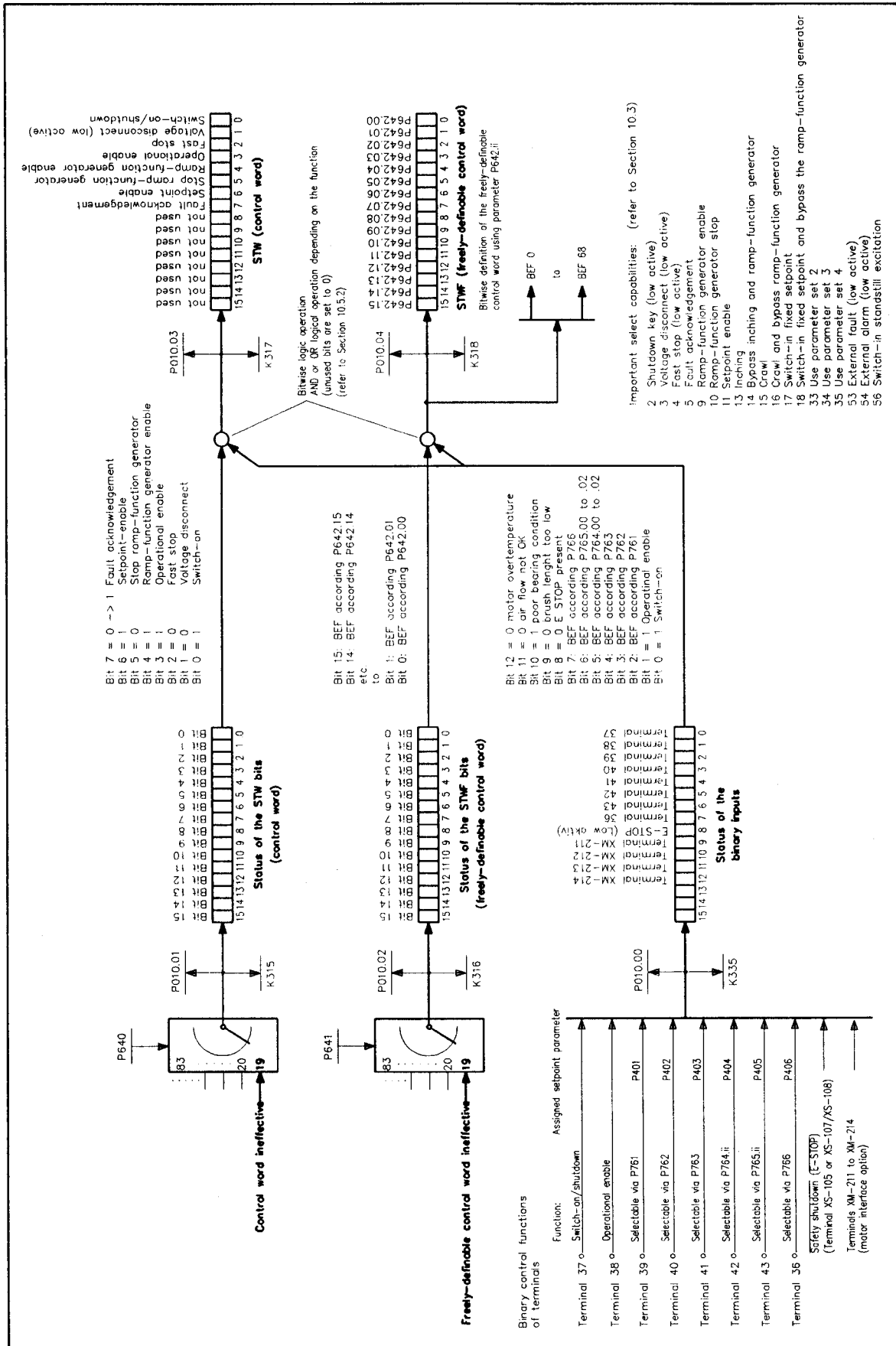

Sheet 7 Free function blocks

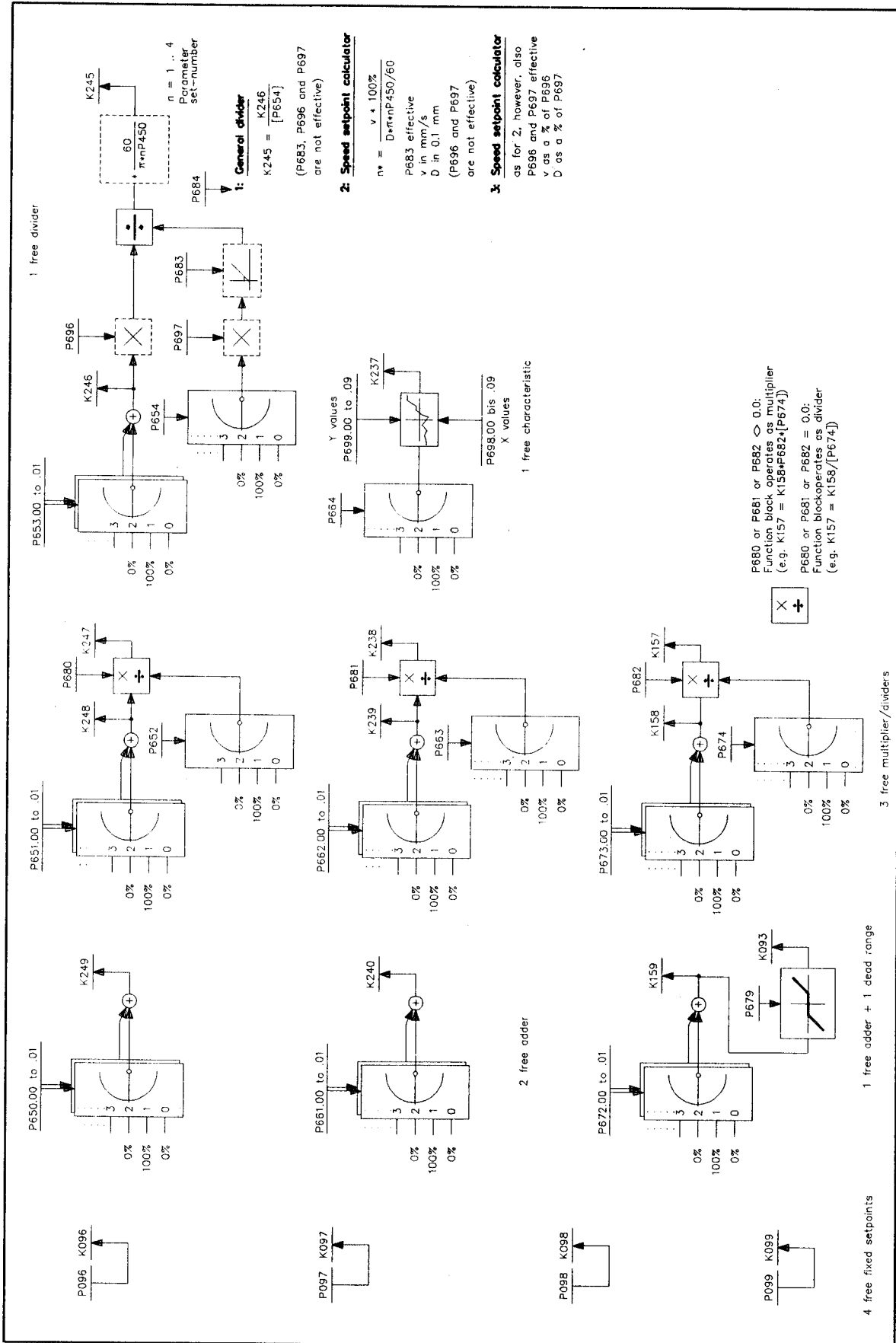

Sheet 8 Free function blocks

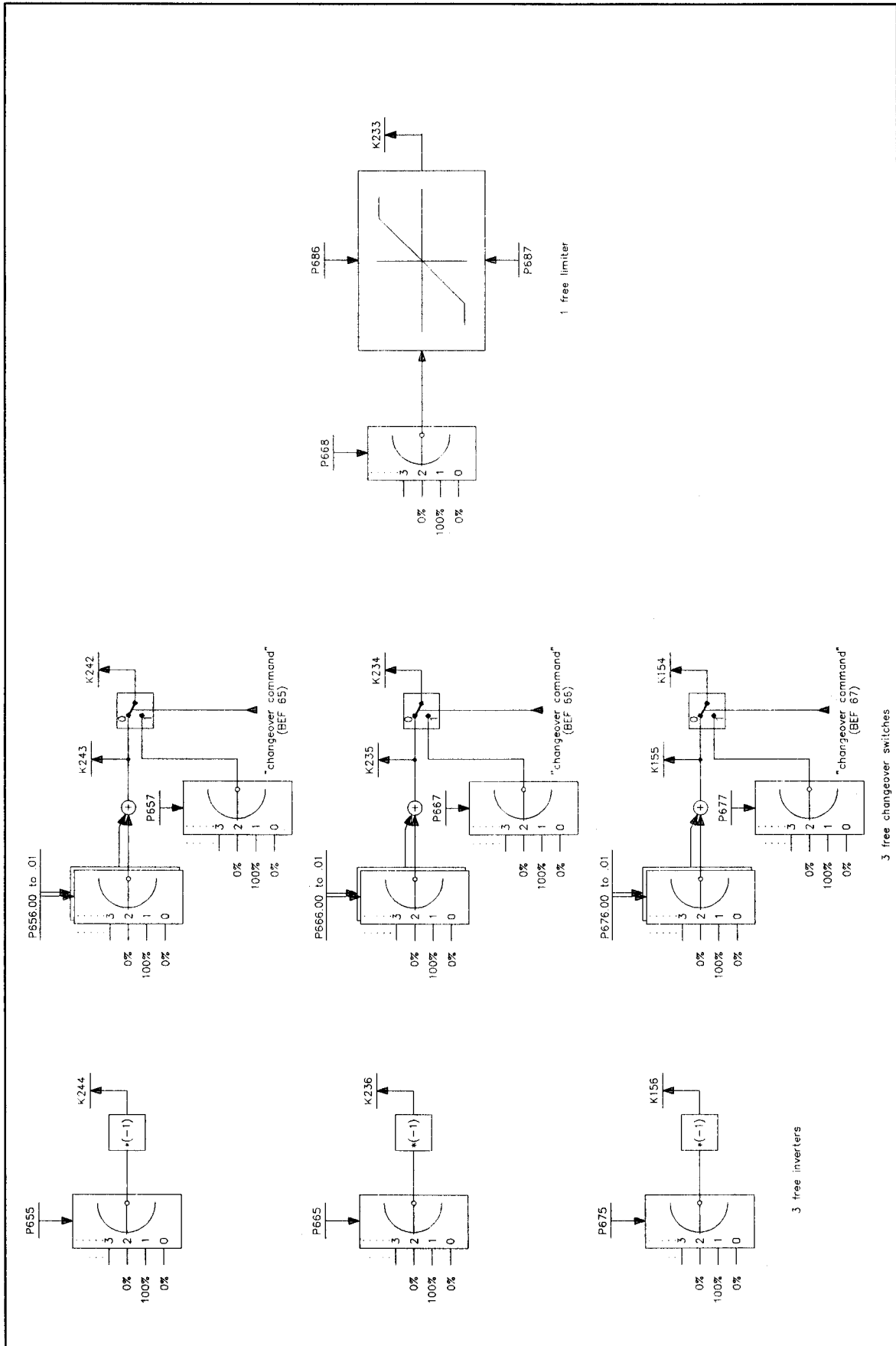



Sheet 9 Free function blocks

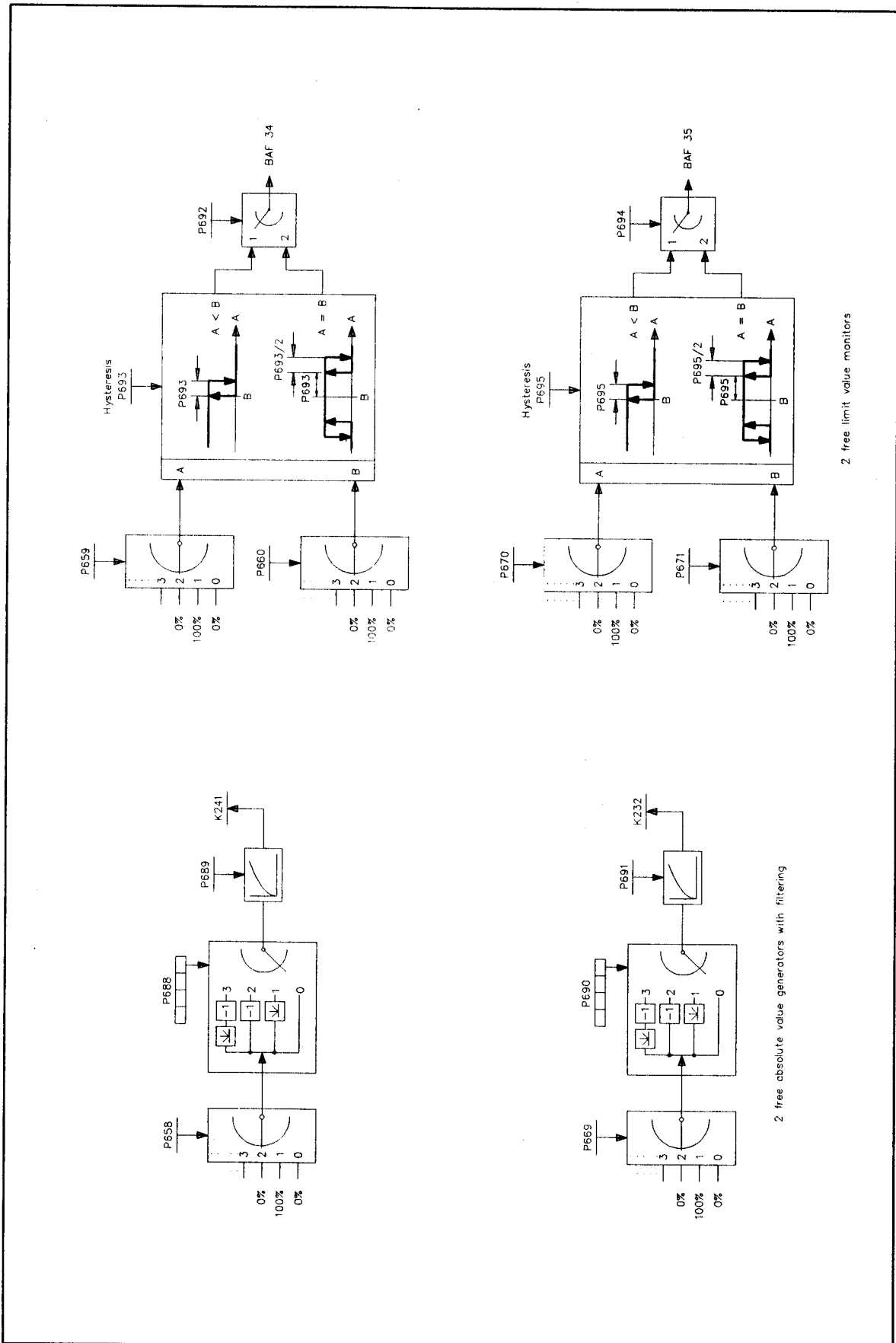

2 free limit value monitors

2 free absolute value generators with filtering

Sheet 10 Technology controller

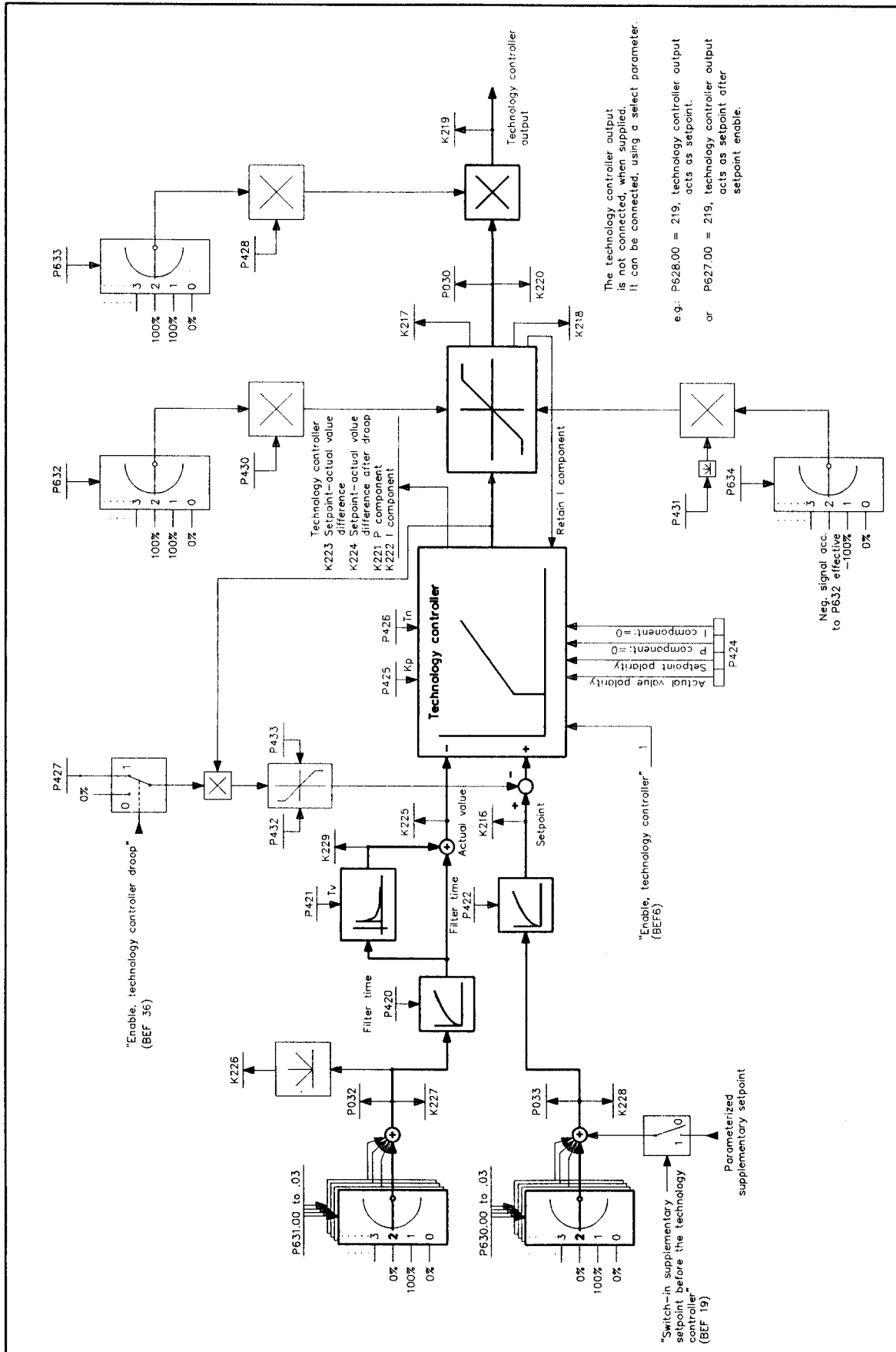

Sheet 11 Motorized potentiometer

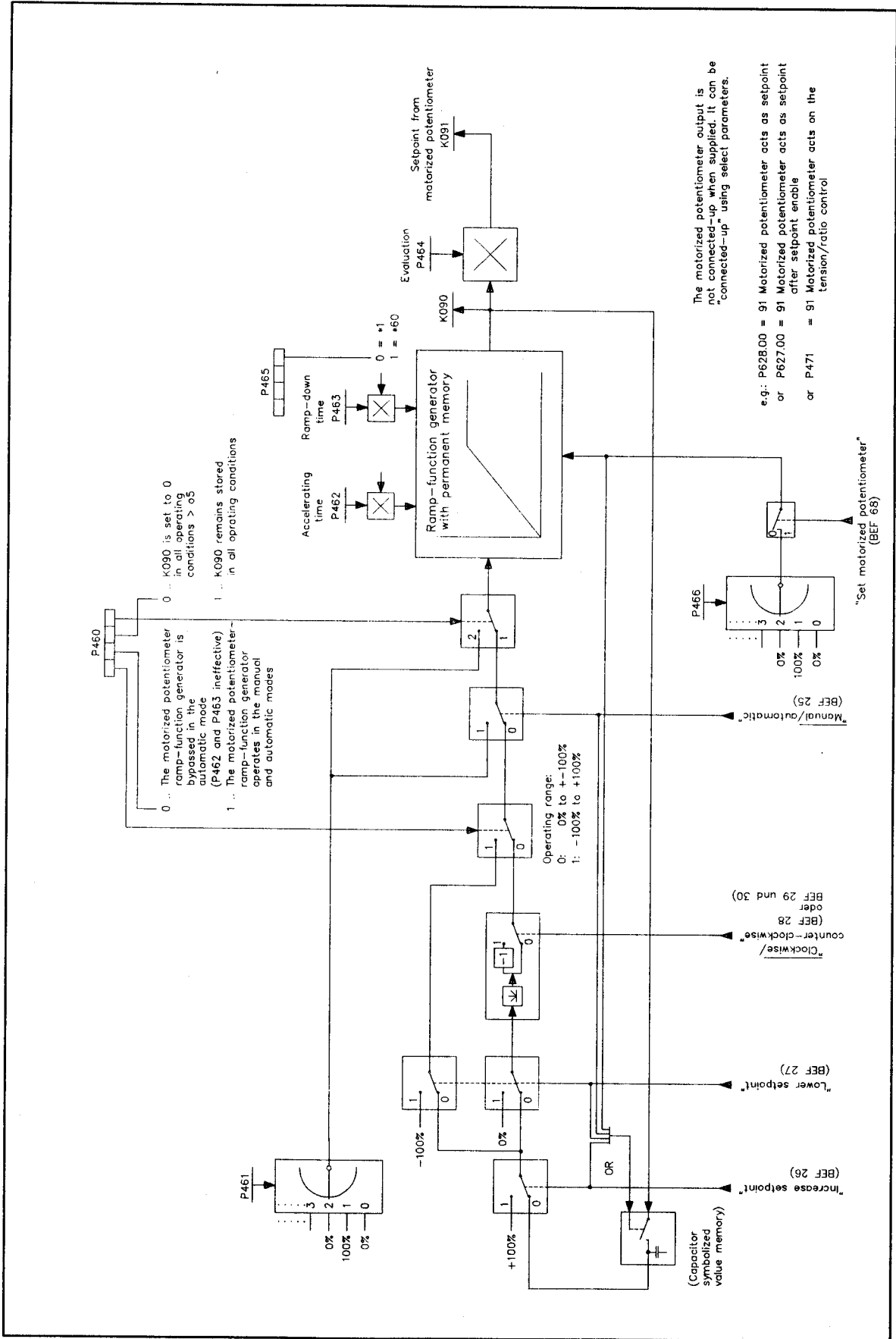

Sheet 12 Setpoint input

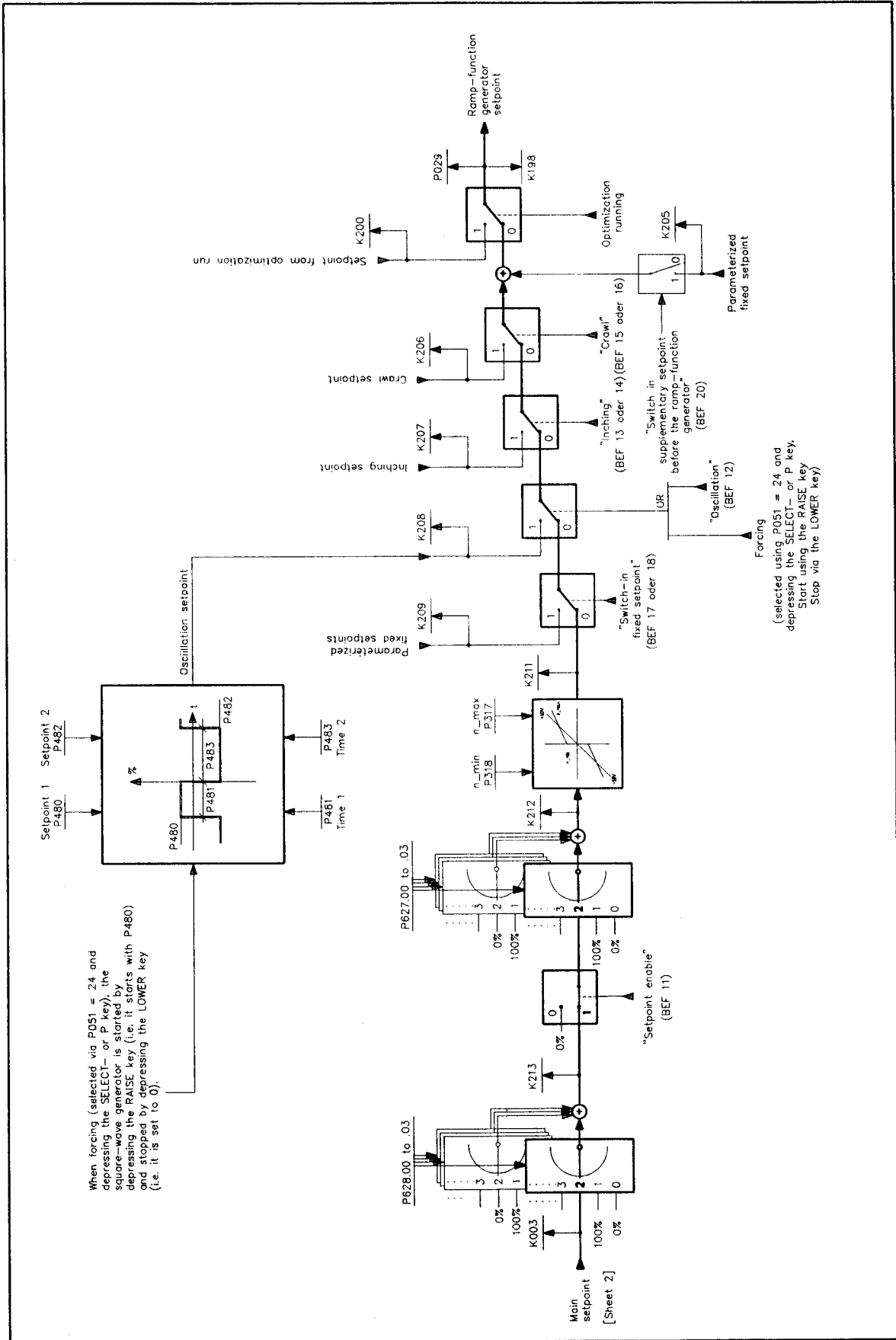

# Sheet 13 Setpoint limiting, tension/ratio control

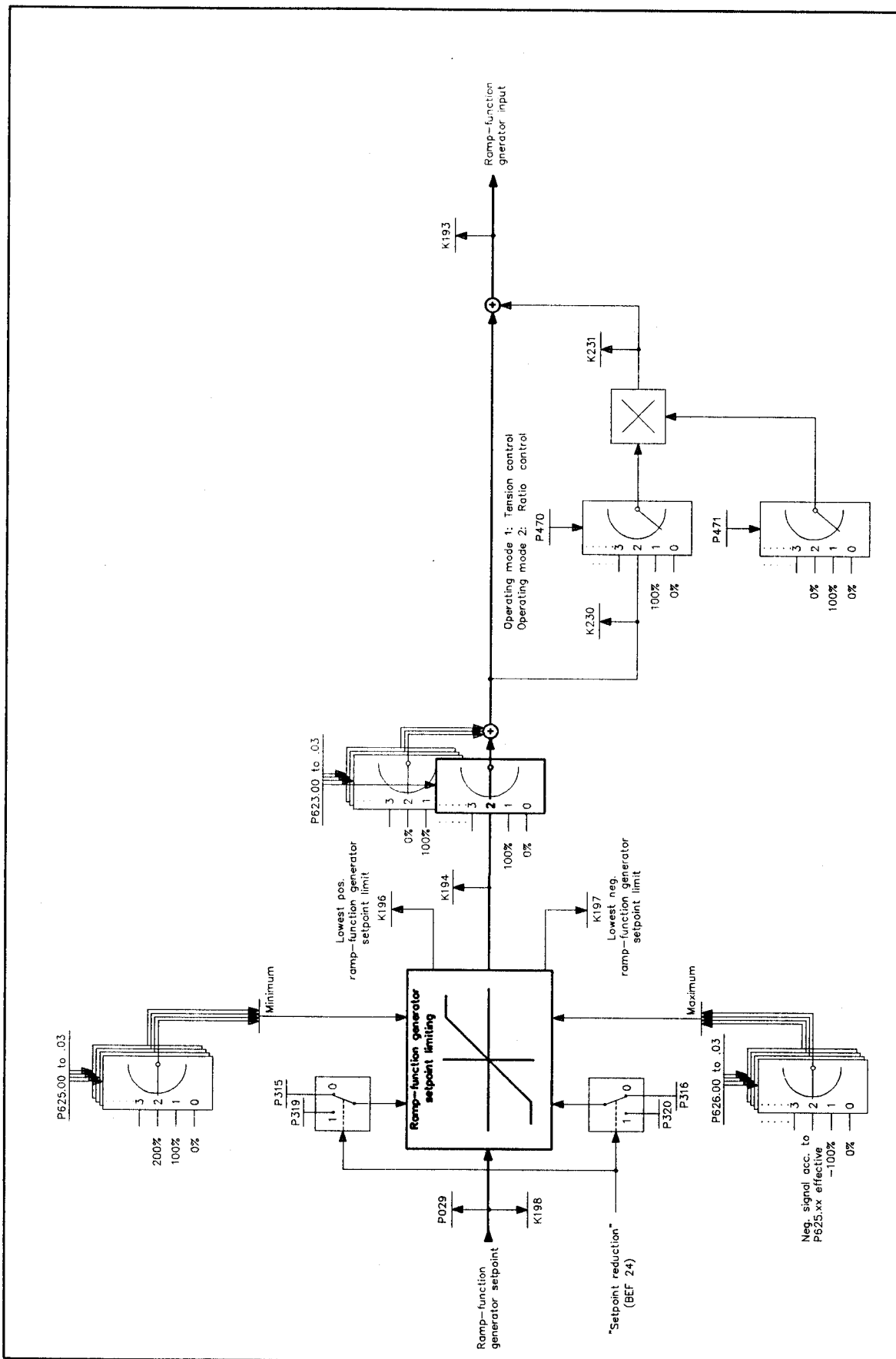

Sheet 14 Ramp-function generator

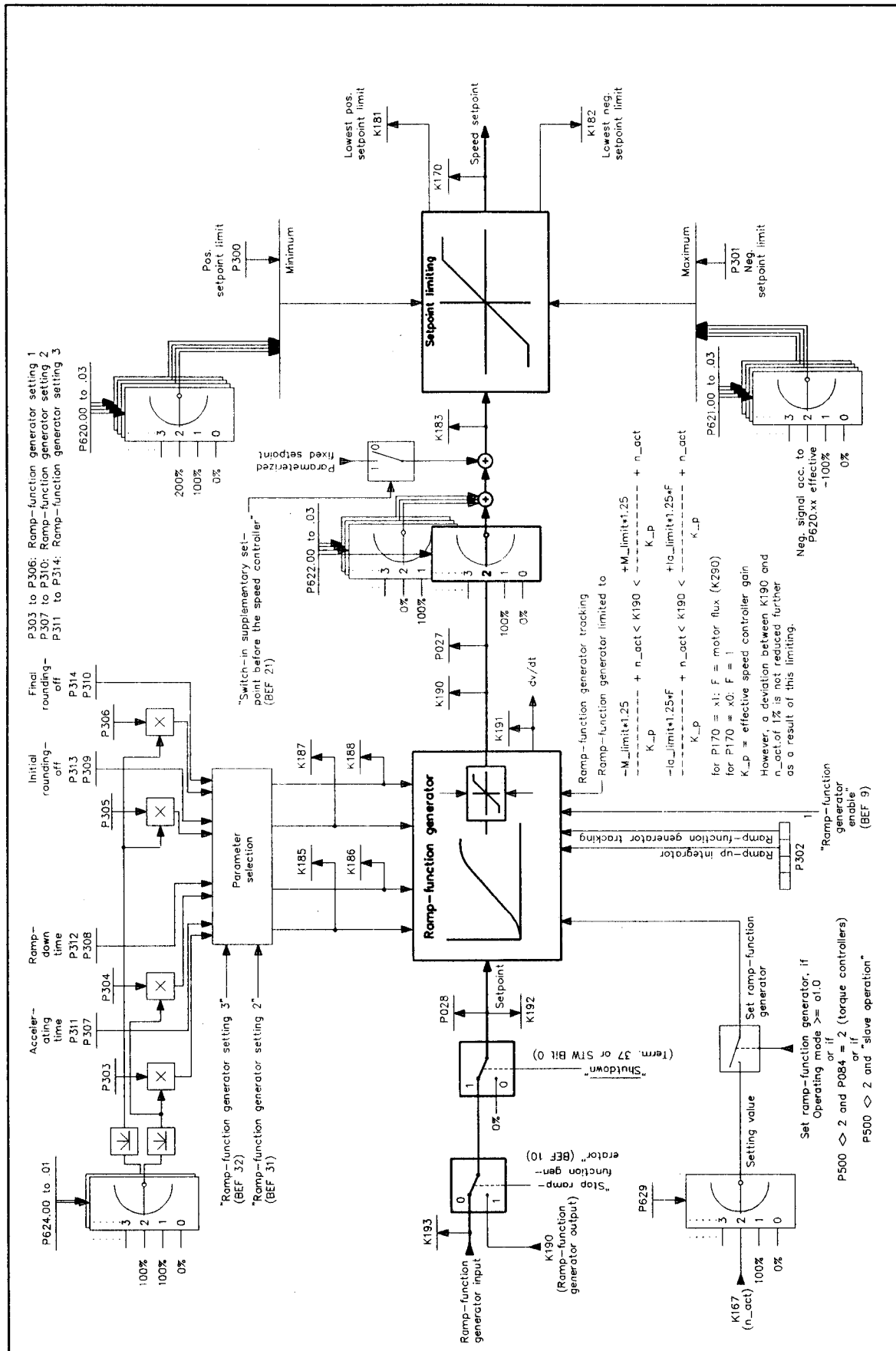

Sheet 15 Closed-loop speed control

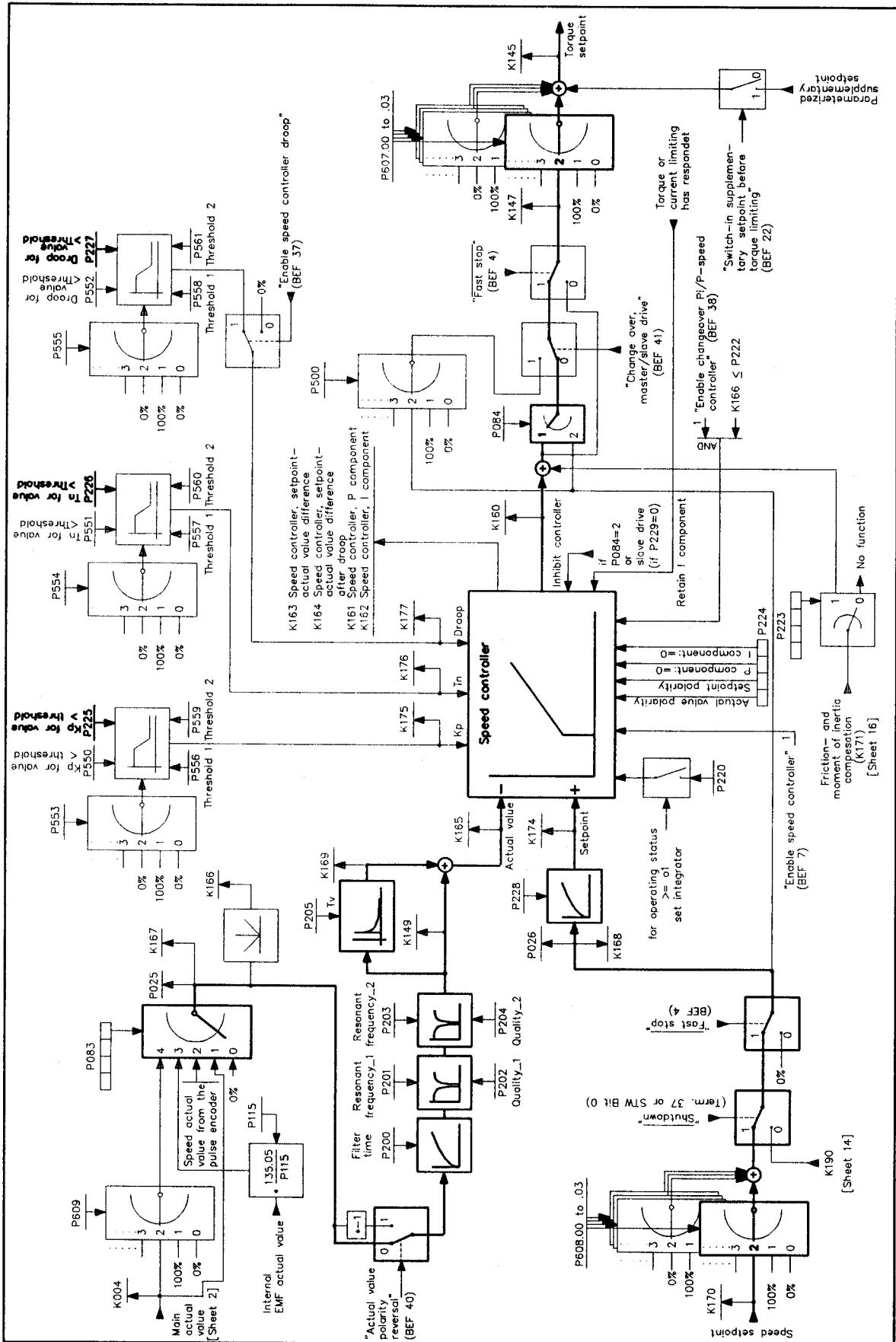

Sheet 16 Compensating friction and moment of inertia

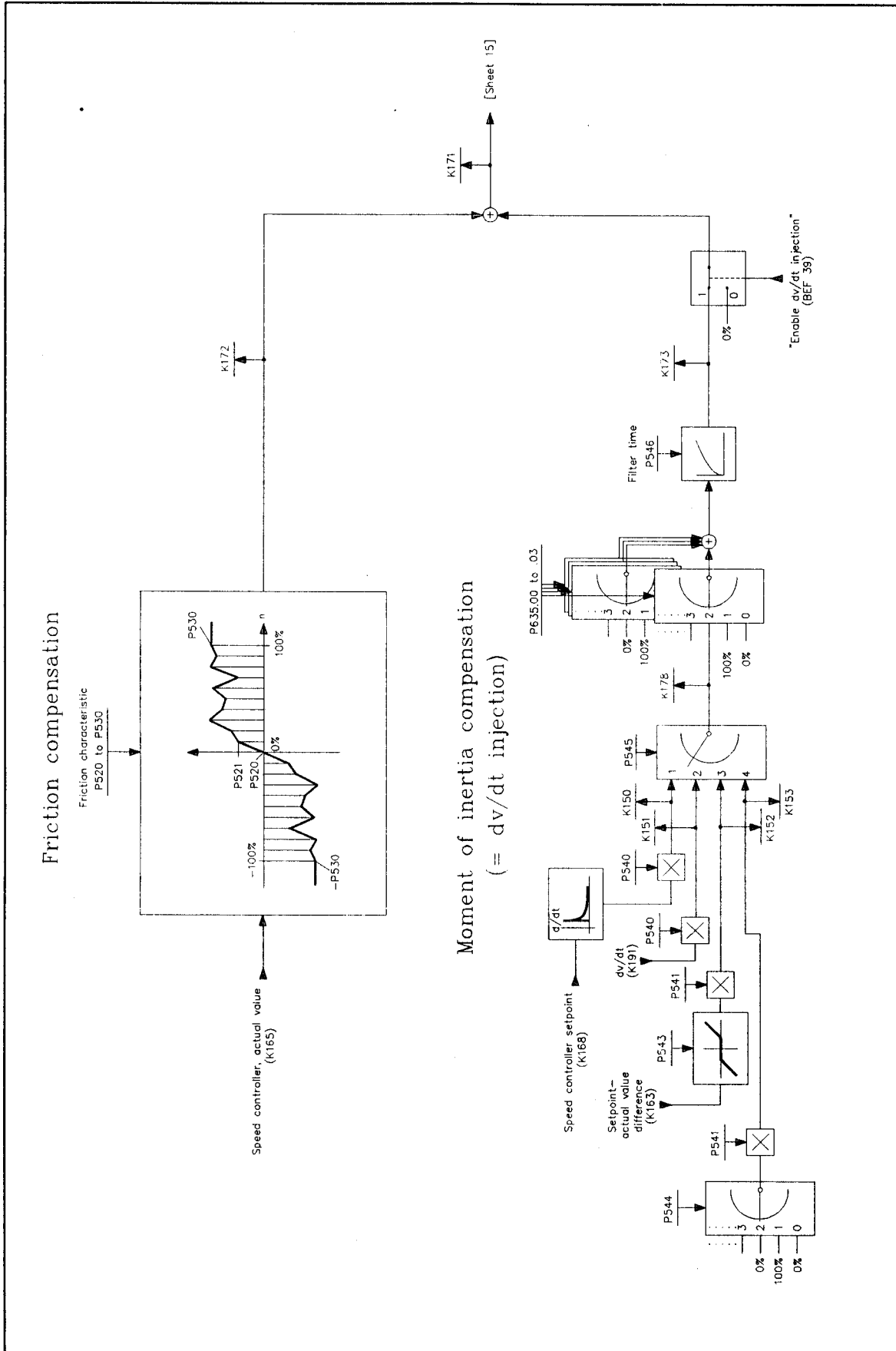



# Sheet 17 Torque limiting, current limiting

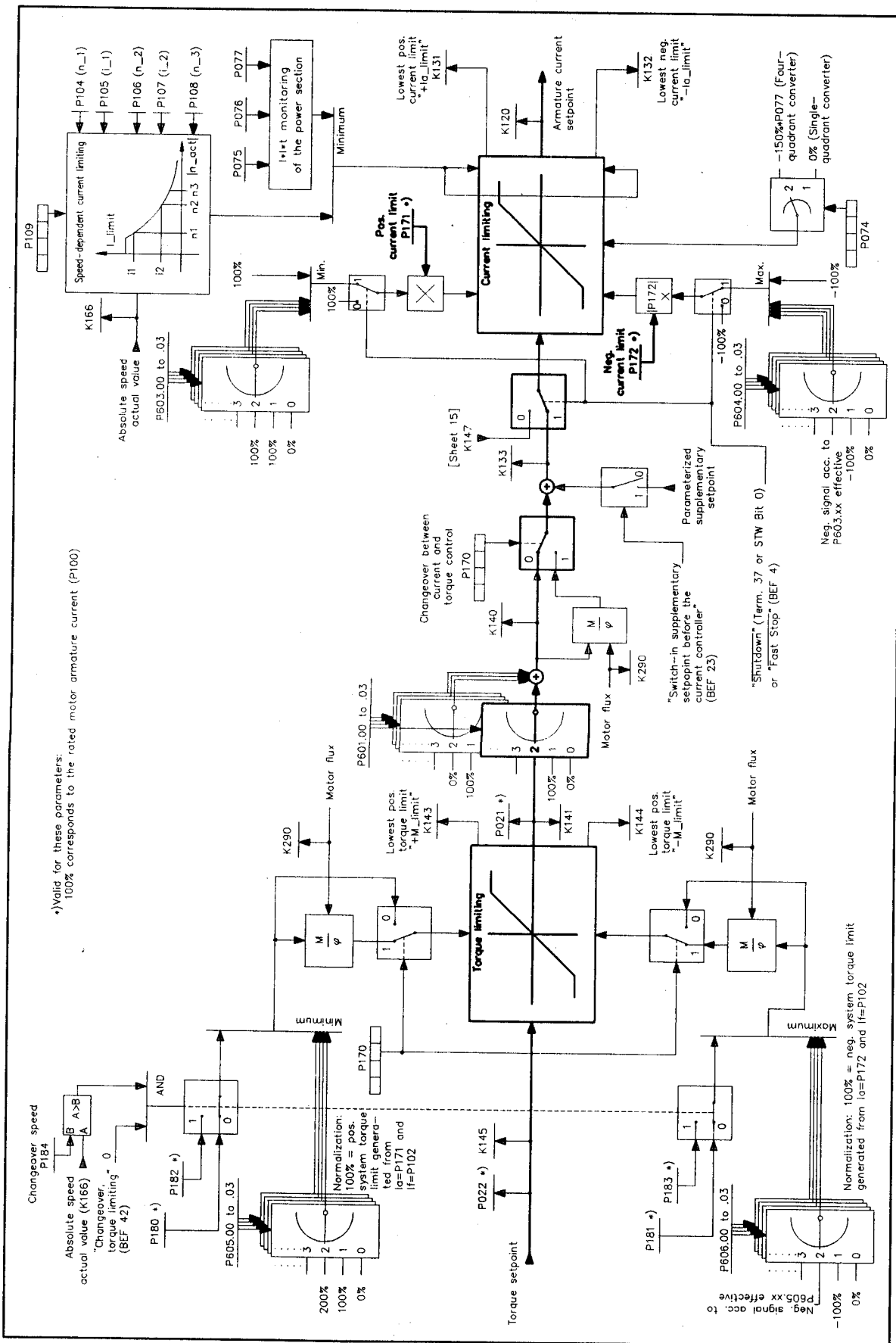



Sheet 19 EMF control

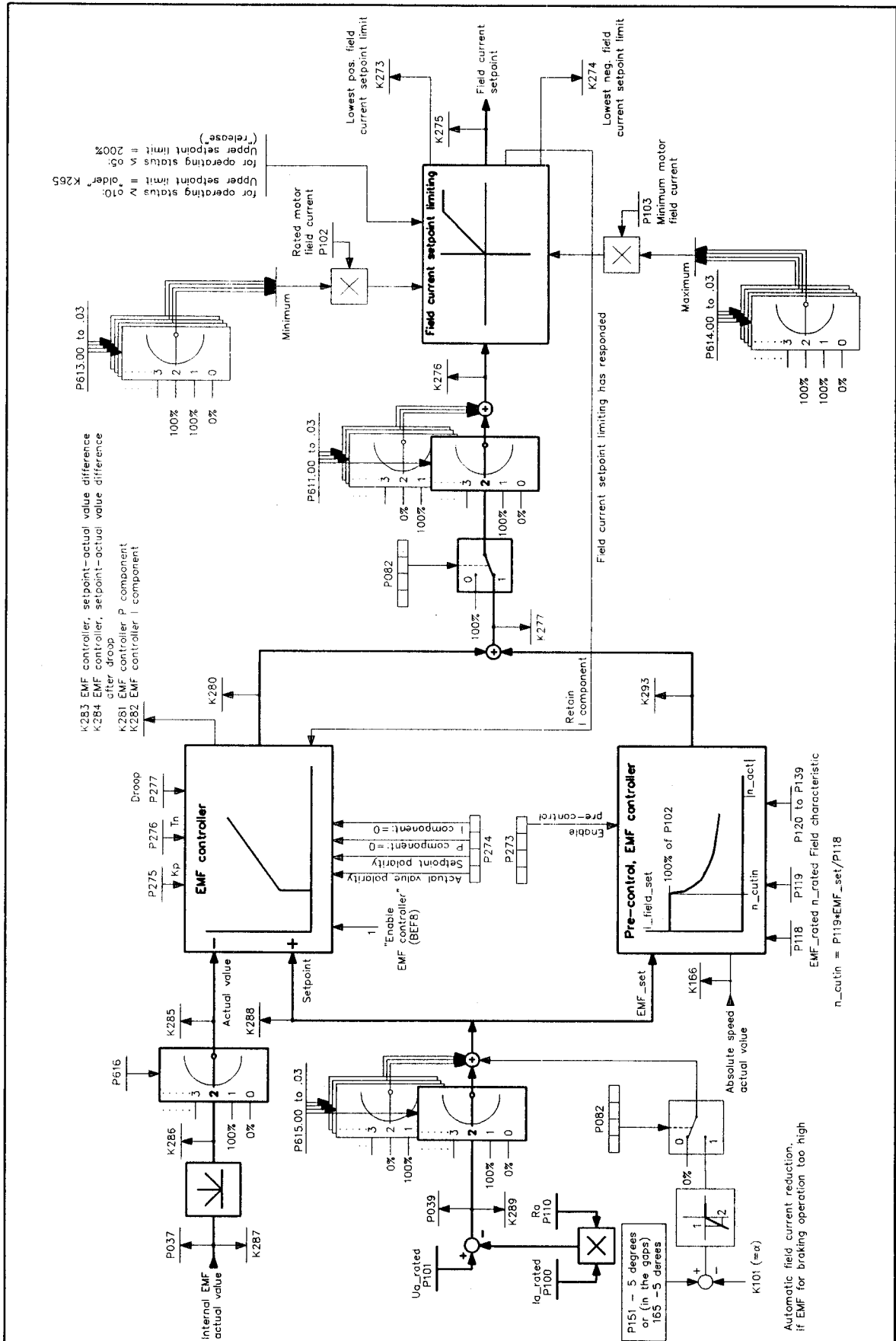

Sheet 20 Field current control, field gating unit

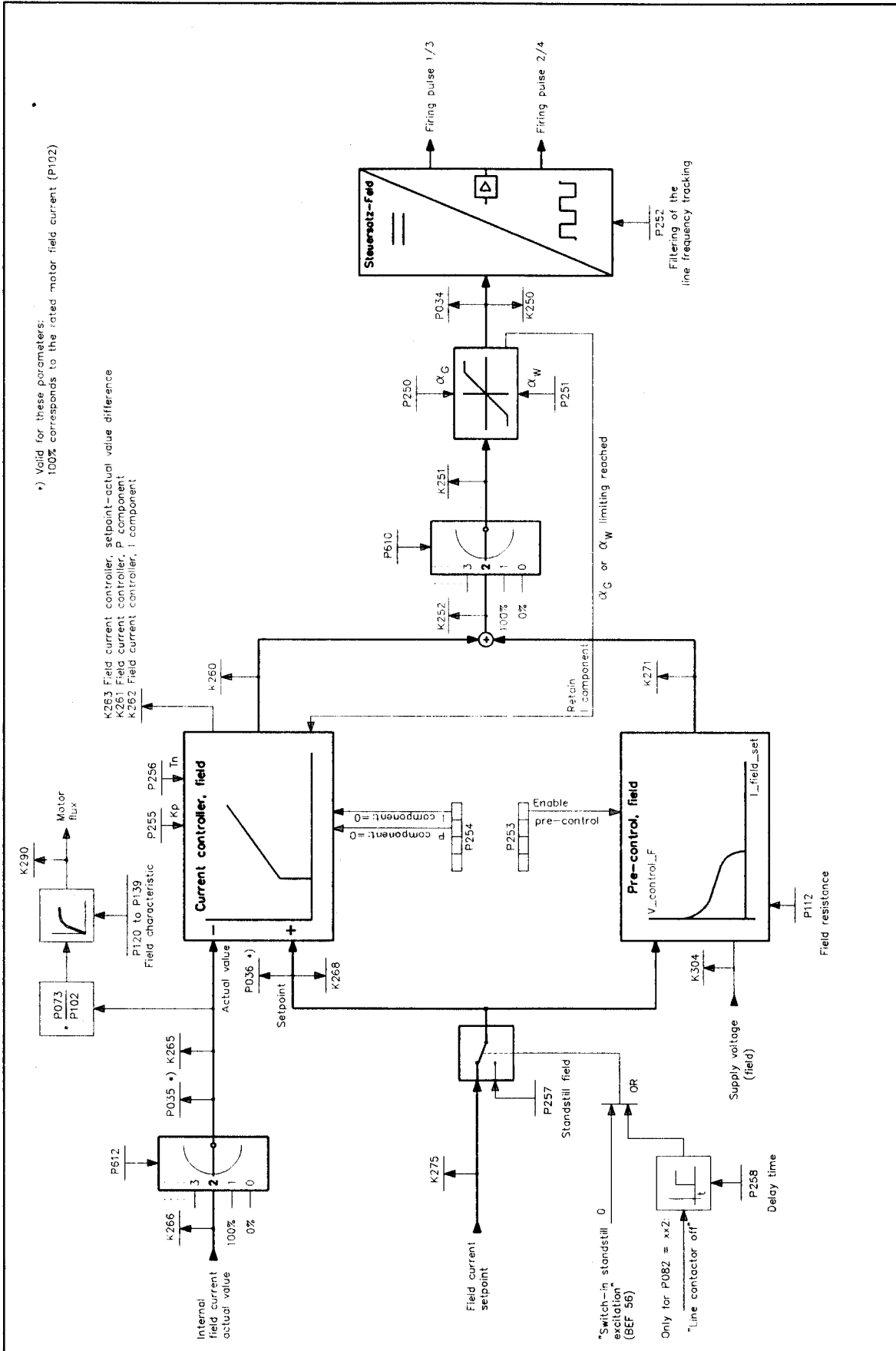

## 10.2 List of connectors

All connectors without normalization instructions are normalized as standard.

Standard normalization: 16384 = 100%

All connectors without instructions are referred to the rated (nominal) converter quantities (e.g. the following is valid for K131: 100% correspond to 16384 = rated converter current).

- K000 Fixed value 0%
- K001 Fixed value 100% (for negative limiting: -100%)
- K002 Parameter-specific standard connector (depending on the particular select parameter)

### Analog inputs

- K003 Main setpoint (terminals 4 and 5, P701 to P704)
- K004 Main actual value (high voltage input) (terminals XT-101 to XT-104, P706 to P709)
- K005 Analog select input 1 (terminals 6 and 7, P711 to P714)
- K006 Analog select input 2 (terminals 8, P716 to P719)
- K007 Analog select input 3 (terminals 10, P721 to P724)
- K008 Measuring sensor temperature at terminals 22 and 23 (in °C)
- K009 Motor temperature (in °C)
- K010 Brush length

### Pulse encoder

- K011 Absolute value of the speed actual value from the pulse encoder (100% ... speed acc. to P143)
- K012 Speed actual value from the pulse encoder, with sign (100% ... speed acc. to P143)
- K013 Position actual value from the pulse encoder (rough) from SW 1.10
- K014 Position actual value from the pulse encoder (fine) from SW 1.10

### Analog outputs

- K015 Analog select output 1 (terminal 14, P741 to P744)
- K016 Analog select output 2 (terminal 16, P746 to P749)
- K017 Analog select output 3 (terminal 18, P750 to P751)
- K018 Analog select output 4 (terminal 20, P755 to P759)

### Serial interfaces of the basic converter

- K019 Application-specific significance: from SW 1.10
  - when used as control word ineffective (acts like the value: 0000 0000 0111 1111)
  - when used as freely-definable control word, ineffective
  - otherwise acts like K000 (fixed value 0%)
- K020 1st receive data at G-SST0 from SW 1.10
- K021 2nd receive data at G-SST0 from SW 1.10
- etc. to
- K035 16th receive data at G-SST0 from SW 1.10
- K036 1st receive data at G-SST1 from SW 1.10
- K037 2nd receive data at G-SST1 from SW 1.10
- etc. to
- K051 16th receive data at G-SST1 from SW 1.10

**PZD channels in the dual port RAM**

|         |  |             |
|---------|--|-------------|
| K052    | 1st receive data at PZD-SOW channel 1  | from SW1.10 |
| K053    | 2nd receive data at PZD-SOW channel 1  | from SW1.10 |
| etc. to |  |             |
| K067    | 16th receive data at PZD-SOW channel 1 | from SW1.10 |
| K068    | 1st receive data at PZD-SOW channel 2  | from SW1.10 |
| K069    | 2nd receive data PZD-SOW channel 2     | from SW1.10 |
| etc. to |  |             |
| K083    | 16th receive data at PZD-SOW channel 2 | from SW1.10 |

**Connectors for the motorized potentiometer**

|      |   |             |
|------|---|-------------|
| K090 | Motorized potentiometer output                  | from SW1.10 |
| K091 | Evaluated output of the motorized potentiometer | from SW1.10 |

**Connectors for free function blocks**

|      |                               |             |
|------|-------------------------------|-------------|
| K093 | Output of the free dead range | from SW2.00 |
|------|-------------------------------|-------------|

**Freely-definable fixed values**

|      |                      |             |
|------|----------------------|-------------|
| K096 | Fixed value 1 (P096) | from SW2.00 |
| K097 | Fixed value 2 (P097) | from SW2.00 |
| K098 | Fixed value 3 (P098) | from SW2.00 |
| K099 | Fixed value 4 (P099) |             |

**Connectors for the torque shell****Gating unit**

|      |  |             |
|------|--|-------------|
| K100 | Firing angle (armature)<br>(16384 corresponds to 0°, 0 corresponds to 90°, -16384 corresponds to 180°)   |             |
| K101 | Firing angle (armature) before limiting<br>(16384 corresponds to 0°, 0 corresponds to 90°, -16384 corresponds to 180°)                                       |             |
| K102 | Input, gating unit (= pre-control value + armature current controller output)<br>(16384 corresponds to 0°, 0 corresponds to 90°, -16384 corresponds to 180°) |             |
| K105 | Code of the triggered thyristor pair of a thyristor bridge for switching-through the appropriate supply phase  | from SW2.00 |
|      | 0 UV                      2 UW                      4 VW   |             |
|      | 6 VU                      8 WU                      10 WV  |             |

**Current control**

|      |   |
|------|---|
| K110 | Current controller output (armature)  |
| K111 | Current controller output, P component (armature)   |
| K112 | Current controller output, I component (armature)   |
| K113 | Current controller, setpoint-actual value difference (armature)   |
| K114 | Internal current controller actual value, with sign (armature), averaged over a firing cycle                  |
| K115 | Current controller actual value (armature)  |
| K116 | Internal absolute current actual value (armature)   |
| K117 | Internal current actual value, with sign (armature)   |
| K118 | Current controller setpoint (armature)  |
| K119 | Current controller setpoint (armature) before absolute value generation                                       |
| K120 | Current controller setpoint (armature) before gearbox stress reduction  |
| K121 | Output, pre-control (armature)<br>(16384 corresponds to 0°, 0 corresponds to 90°, -16384 corresponds to 180°) |

**Current limiting**

|      |   |  |
|------|---|--|
| K131 | Lowest positive current limit (armature)    |  |
| K132 | Lowest negative current limit (armature)    |  |
| K133 | Current setpoint (armature) before limiting |  |

**Torque limiting**

|      |  |             |
|------|--|-------------|
| K140 | Torque setpoint  |             |
| K141 | Torque setpoint after limiting   |             |
| K142 | Torque actual value  | from SW1.10 |
| K143 | Lowest positive torque limit (armature)  |             |
| K144 | Lowest negative torque limit (armature)  |             |
| K145 | Torque setpoint before limiting  |             |
| K147 | Pre-control value + speed controller output  |             |
| K149 | Speed controller actual value with sign, after actual value polarity reversal, filtering and the two inhibit filters | from SW2.00 |

**Connectors for the speed controller pre-control**

(also refer to P545 in Section 9.2)

|      |   |             |
|------|---|-------------|
| K150 | Component of the pre-control for the speed controller calculated from $d(K168) / dt * P540$ (= acceleration switched-in)                                    | from SW2.00 |
| K151 | Component of the pre-control for the speed controller calculated from $K191 * P540 / (\text{supply periods} / 6)$ (= acceleration switched-in)              | from SW2.00 |
| K152 | Component of the pre-control for the speed controller calculated from $f(K163) * P541$<br>(= function of the speed setpoint - actual value difference K163) | from SW2.00 |
| K153 | Component of the pre-control for the speed controller calculated from $[P544] * P541$<br>(= freely-connectable component, selected using P544)              | from SW2.00 |

**Connectors for the free function blocks**

|      |                                     |             |
|------|-------------------------------------|-------------|
| K154 | Output of free changeover switch 3  | from SW2.00 |
| K155 | Input A of free changeover switch 3 | from SW2.00 |
| K156 | Output of free inverter 3           | from SW2.00 |
| K157 | Output of free multiplier 3         | from SW2.00 |
| K158 | Input A of free multiplier 3        | from SW2.00 |
| K159 | Output of free adder 3              | from SW2.00 |

## Speed control connectors

### Speed controller

|      |  |                            |
|------|--|----------------------------|
| K160 | Speed controller output  |                            |
| K161 | Speed controller, P component  |                            |
| K162 | Speed controller, I component  |                            |
| K163 | Speed controller, setpoint-actual value difference   |                            |
| K164 | Speed controller, setpoint-actual value difference after droop                             |                            |
| K165 | Speed controller actual value  |                            |
| K166 | Absolute speed actual value  |                            |
| K167 | Speed actual value, with sign  |                            |
| K168 | Speed controller setpoint  |                            |
| K169 | D component of the speed controller actual value   | from SW1.10                |
| K170 | Speed setpoint   |                            |
| K171 | Pre-control for the speed controller   | from SW1.10                |
| K172 | Friction-related component of the pre-control for the speed controller                     | from SW1.10                |
| K173 | Filtered moment of inertia-related component of the pre-control for the speed controller   | from SW1.10<br>from SW2.00 |
| K174 | Speed controller setpoint, filtered  | from SW2.00                |
| K175 | Effective P gain $K_p$ (in 0.01)   |                            |
| K176 | Effective integral action time $T_n$ (in 0.001s)   |                            |
| K177 | Effective droop (in 0.1% of the rated motor torque)  |                            |
| K178 | Unfiltered moment of inertia-related component of the pre-control for the speed controller | from SW2.00                |

### Speed setpoint limiting

|      |                                      |
|------|--------------------------------------|
| K181 | Lowest positive speed setpoint limit |
| K182 | Lowest negative speed setpoint limit |
| K183 | Speed setpoint before limiting       |

### Ramp-function generator

|      |   |
|------|---|
| K185 | Effective ramp-up time (in 0.01s)   |
| K186 | Effective ramp-down time (in 0.01s)   |
| K187 | Effective initial rounding-off (in 0.001s)  |
| K188 | Effective final rounding-off (in 0.001s)  |
| K190 | Ramp-function generator output  |
| K191 | Ramp-function generator rate of change (ramp-function generator output increments per firing cycle) (also refer to P545 in Section 9.2) |
| K192 | Ramp-function generator input   |
| K193 | Ramp-function generator input after setpoint addition of tension/ratio control  |
| K194 | Ramp-function generator input after limiting  |

### Ramp-function generator setpoint limiting

|      |  |
|------|--|
| K196 | Lowest positive ramp-function generator setpoint limit |
| K197 | Lowest negative ramp-function generator setpoint limit |
| K198 | Ramp-function generator input before limiting          |



### Connectors for the digital setpoint inputs

|      |   |             |
|------|---|-------------|
| K200 | Setpoint 0 from the optimization run  |             |
| K201 | Setpoint 1 from the optimization run  |             |
| K202 | Setpoint 2 from the optimization run  |             |
| K203 | Setpoint 3 from the optimization run  |             |
| K204 | Setpoint 4 from the optimization run  |             |
| K205 | Supplementary setpoint before the ramp-function generator setpoint limiting |             |
| K206 | Crawl setpoint  |             |
| K207 | Inching setpoint  |             |
| K208 | Oscillation setpoint  | from SW2.00 |
| K209 | Setpoint from parameterized fixed values                                    |             |
| K211 | Ramp-function generator input after setpoint branching                      |             |
| K212 | Ramp-function generator input before setpoint branching                     |             |
| K213 | Ramp-function generator input before setpoint enable                        |             |

### Connectors for the technology controller

|      |  |             |
|------|--|-------------|
| K216 | Technology controller setpoint, filtered                                       | from SW2.00 |
| K217 | Positive limit for the technology controller output                            | from SW2.00 |
| K218 | Negative limit for the technology controller output                            | from SW2.00 |
| K219 | Technology controller output (after multiplication with the evaluation factor) | from SW1.10 |
| K220 | Technology controller output   | from SW1.10 |
| K221 | Technology controller, P component   | from SW1.10 |
| K222 | Technology controller, I component   | from SW1.10 |
| K223 | Technology controller, setpoint-actual value difference                        | from SW1.10 |
| K224 | Technology controller, setpoint- actual value difference after droop           | from SW1.10 |
| K225 | Technology controller actual value   | from SW1.10 |
| K226 | Absolute technology actual value   | from SW1.10 |
| K227 | Technology actual value, with sign   | from SW1.10 |
| K228 | Technology controller setpoint   | from SW1.10 |
| K229 | D component of the technology controller actual value                          | from SW1.10 |

### Connectors for tension/ratio control

|      |   |             |
|------|---|-------------|
| K230 | Ramp-function generator setpoint before the tension/ratio control becomes effective | from SW1.10 |
| K231 | Supplementary setpoint from the tension/ratio control                               | from SW1.10 |

### Connectors for the free function blocks

|      |   |             |
|------|---|-------------|
| K232 | Output of free absolute value generator 2 | from SW2.00 |
| K233 | Output of free limiter                    | from SW2.00 |
| K234 | Output of free changeover switch 2        | from SW2.00 |
| K235 | Input A of free changeover switch 2       | from SW2.00 |
| K236 | Output of free inverter 2                 | from SW2.00 |
| K237 | Output of the free characteristic         | from SW2.00 |
| K238 | Output of free multiplier 2               | from SW2.00 |
| K239 | Input A of free multiplier 2              | from SW2.00 |
| K240 | Output of free adder 2                    | from SW2.00 |
|      |   |             |
| K241 | Output of free absolute value generator 1 | from SW2.00 |
| K242 | Output of free changeover switch 1        | from SW2.00 |
| K243 | Input A of free changeover switch 1       | from SW2.00 |
| K244 | Output of free inverter 1                 | from SW2.00 |
| K245 | Output of free divider                    | from SW2.00 |
| K246 | Input A of free divider                   | from SW2.00 |
| K247 | Output of free multiplier 1               | from SW2.00 |
| K248 | Input A of free multiplier 1              | from SW2.00 |
| K249 | Output of free adder 1                    | from SW2.00 |

### Connectors for the closed-loop field control

#### Field gating unit

|      |  |
|------|--|
| K250 | Firing angle (field) (16384 corresponds to 0°, 0 corresponds to 90°, -16384 corresponds to 180°)   |
| K251 | Firing angle (field) before limiting<br>(16384 corresponds to 0°, 0 corresponds to 90°, -16384 corresponds to 180°)                                    |
| K252 | Gating unit input (pre-control value + field current controller output)<br>(16384 corresponds to 0°, 0 corresponds to 90°, -16384 corresponds to 180°) |

#### Field current control

|      |  |
|------|--|
| K260 | Current controller output (field)                            |
| K261 | Current controller, P component (field)                      |
| K262 | Current controller, I component (field)                      |
| K263 | Current controller, setpoint-actual value difference (field) |
|      |  |
| K265 | Actual value at the field current controller input           |
| K266 | Internal actual value (field)                                |
|      |  |
| K268 | Setpoint at the field current controller input               |
|      |  |
| K271 | Pre-control output (field)                                   |

#### Field current setpoint limiting

|      |   |
|------|---|
| K273 | Lowest positive current limit (field)                           |
| K274 | Lowest negative current limit (field)                           |
| K275 | Current controller setpoint (field) before the standstill field |
| K276 | Current controller setpoint (field) before limiting             |
| K277 | Pre-control value + EMF controller output                       |

### Connectors for the closed-loop EMF control

|      |   |
|------|---|
| K280 | EMF controller output   |
| K281 | EMF controller, P component   |
| K282 | EMF controller, I component   |
| K283 | EMF controller, setpoint-actual value difference  |
| K284 | EMF controller, setpoint-actual value difference after droop                              |
| K285 | EMF controller actual value ( $16384 \hat{=} P071 * \frac{3\sqrt{2}}{\pi}$ )              |
| K286 | Absolute EMF actual value ( $16384 \hat{=} P071 * \frac{3\sqrt{2}}{\pi}$ )                |
| K287 | EMF actual value with sign ( $16384 \hat{=} P071 * \frac{3\sqrt{2}}{\pi}$ )               |
| K288 | EMF controller setpoint ( $16384 \hat{=} P071 * \frac{3\sqrt{2}}{\pi}$ )                  |
| K289 | Absolute value of the EMF setpoint ( $16384 \hat{=} P071 * \frac{3\sqrt{2}}{\pi}$ )       |
| K290 | Motor flux (100% = 16384 = flux at the rated motor field current)                         |
| K291 | Absolute armature voltage actual value ( $16384 \hat{=} P071 * \frac{3\sqrt{2}}{\pi}$ )   |
| K292 | Armature voltage actual value, with sign ( $16384 \hat{=} P071 * \frac{3\sqrt{2}}{\pi}$ ) |
| K293 | Pre-control output (EMF)  |

### General connectors

|      |   |
|------|---|
| K300 | Operating status (code number) to one decimal place   |
| K301 | Supply voltage U-V (armature) (16384 corresponds to P071)   |
| K302 | Supply voltage V-W (armature) (16384 corresponds to P071)   |
| K303 | Supply voltage W-U (armature) (16384 corresponds to P071)   |
| K304 | Supply voltage (field) (16384 corresponds to 400V)  |
| K305 | Average supply voltage (armature) filtered (16384 corresponds to P071)  |
| K306 | Supply frequency (16384 corresponds to 50.0Hz)  |
| K307 | Motor output (16384 corresponds to $P100 * (P101 - P100 * P110)$ from SW1.10)   |
| K309 | Calculated motor temperature rise (16384 corresponds to that temperature rise, which is obtained, for a continuous current which is identical to the rated motor armature current)  |
| K310 | Calculated thyristor temperature rise (calculated equivalent barrier junction temperature rise as a % of the maximum permissible barrier junction temperature rise)<br>(16384 corresponds to 80°C temperature rise for 15A to 60A converters<br>85°C temperature rise for 90A to 140A converters<br>90°C temperature rise for >200A converters) |
| K311 | Operating hours   |

|      |  |             |
|------|--|-------------|
| K315 | Control word STW (refer to P010.01 in Section 9.2)   | from SW1.10 |
| K316 | Freely-definable control word STWF (refer to P010.02 in Section 9.2)   | from SW1.10 |
| K317 | Control word STW + binary input functions from the terminals<br>(refer to P010.03 in Section 9.2)  | from SW2.00 |
| K318 | Freely-definable control word STWF + binary input functions from the terminals<br>(refer to P010.04 in Section 9.2)                          | from SW2.00 |
| K325 | Status word ZSW (refer to P011.01 in Section 9.2)  |             |
| K326 | Status word ZSW1 (refer to P011.02 in Section 9.2)   | from SW1.10 |
| K327 | Status word ZSW2 (refer to P011.03 in Section 9.2)   | from SW1.10 |
| K330 | Limiting bits (refer to P040 in Section 9.2)   | from SW2.00 |
| K331 | Alarm memory 1 (refer to P049 and W00 to W14 in Section 8.3.1)   |             |
| K332 | Alarm memory 2 (refer to P050 and W16 to W30 in Section 8.3.1)   |             |
| K335 | Status of the binary inputs (refer to Section 9.2 parameter P010.00)   |             |
| K336 | Status of the binary outputs (refer to Section 9.2 parameter P011.00)  |             |
| K350 | Program step number, which is displayed at the left of the operator control panel during an optimization run                                 | from SW2.00 |
| K351 | Number of repeat operations of the optimization run step, specified using K350   | from SW2.00 |
| K352 | Program step number, which is displayed at the right of the operator control panel during an optimization run                                | from SW2.00 |
| K353 | Number of repeat operations of the optimization run step, specified using K352   | from SW2.00 |
| K380 | Positive supply zero crossover, phase U-V (as T1 instant)  |             |
| K381 | Negative supply zero crossover, phase W-U (as T1 instant)  |             |
| K382 | Positive supply zero crossover, phase V-W (as T1 instant)  |             |
| K383 | Negative supply zero crossover, phase U-V (as T1 instant)  |             |
| K384 | Positive supply zero crossover, phase W-U (as T1 instant)  |             |
| K385 | Negative supply zero crossover, phase V-W (as T1 instant)  |             |
| K386 | Last used supply zero crossover (as T1 instant)  |             |
| K387 | Armature firing instant (as T1 instant)  |             |
| K388 | Firing pulse cycle duration (time difference of the actual to the previous armature firing instant) (in T1 increments, each 1.77778 $\mu$ s) |             |
| K390 | Overall processor utilization  |             |
| K391 | Interpolated overall processor utilization at the maximum supply frequency (65Hz)  |             |
| K392 | Overall processor utilization by the background programs   |             |
| K393 | Overall processor utilization by programs in synchronism with the the field firing pulses  |             |
| K394 | Overall processor utilization by programs in synchronism with the armature firing pulses   |             |

### 10.3 Binary input functions

(also refer to the function diagrams in Section 10.1, Sheet 6 as well as "control words" in Section 10.5).

The binary converter functions can be controlled as follows:

- by connecting a low- or high voltage level at the binary input terminals
- by supplying control words with data via a serial interface
- by depressing a key on the operator control panel

A terminal (39, 40, 41, 42, 43, 36) or a bit (0 to 15) of the freely-definable control word STWF can be assigned a specific binary input function (BEF0 to BEF68) by appropriate parameterization.

The "switch-on/shutdown" and "operating enable" functions are permanently assigned to terminals 37 and 38.

Bits (0, 1, ...) of control word STW are permanently assigned specific binary input functions ("switch-on/shutdown", "disconnect voltage", ...).

Select parameter P761 defines the function of terminal 39 (select input, binary 1). <sup>1)</sup>

Select parameter P762 defines the function of terminal 40 (select input, binary 2). <sup>2)</sup>

Select parameter P763 defines the function of terminal 41 (select input, binary 3).

Select parameter P764(.ii) defines the function(s) of terminal 42 (select input, binary 4). <sup>3)</sup>

Select parameter P765(.ii) defines the function(s) of terminal 43 (select input, binary 5). <sup>3)</sup>

Select parameter P766 defines the function of terminal 36 (select input, binary 6).



#### WARNING

When changing parameters P761 to P766, undesirable structural changes or switch-on commands (thus causing the motor to start) can occur, if the appropriate terminal is activated.



It must be ensured, that non of the binary select inputs are activated as long as its function hasn't been completely defined using the appropriate parameter. This can be simply realized by removing ribbon cable connector XB.

From software release 2.00 onwards, the motor is prevented from starting, even when the terminal is activated, by internally entering "switch-on inhibit" when changing an offline parameter. That can lead to operating status o8 (acknowledgement required).

- 1) For P144 = xx2 or xx3, terminal 39 has additionally the "reset position counter" function, in addition to the function selected with P761.
- 2) The terminal has the "reset zero mark counter" function in addition to the function selected with P762 (is presently not evaluated).
- 3) Terminals 42 and 43 can be assigned up to 3 different binary input functions, as P764.ii and P765.ii are indexed parameters (with index ii = 00 to 02). This allows up to three functions to be simultaneously switched with one control signal.

The indexed parameter P642.ii defines the binary input functions assigned to the individual bits (ii = 0 to 15) of the STWF.

Select parameter P641 defines the connector, which supplies the freely-definable control word STWF with data. STWF is ineffective for P641 = 19.



## WARNING



When changing parameters P640 to P642 undesirable structure changes or switch-on commands can occur (thus causing the motor to start), if the appropriate bit is set. Therefore, it must be ensured, that voltage is not present at the power connections, or that at least there is no operating enable as long as these parameters are being changed.

Select parameter P640 defines the connector, which supplies control word STW with data. The control word is ineffective for P640 = 19.

In addition to the specified binary control intervention possibilities, there are **O-** and **I** keys on the operator control panel. These keys must be assigned specific functions using parameters P066 and P067.

The defined function is controlled by a low- or high signal at the binary input terminals or by supplying the control words with data.

The logical status of the binary inputs (terminals, control words), is indicated at display parameter P010.ii (also refer to Section 9.2), and is available at connectors (K315 to K318, K335).

|                        |                        |           |
|------------------------|------------------------|-----------|
| Terminal signal level: | Terminal open-circuit: | logical 0 |
|                        | Terminal energized:    | logical 1 |

For the descriptions, provided from Section 10.3.1 onwards, "level" specifies if this input function acts as logical 0 or logical 1 if it is "not used".

- A specific input function which can be parameterized is considered as "not used" if
- the number of this binary input function is not parameterized at any select parameter P761 to P766 (to define the terminal functions), and if
  - either the number of this binary input function is not parameterized at an index of P642.ii (to define the functions of the STWF bits)
  - or STWF is ineffective as a result of the parameterization P641 = 19.

### Note:

The appropriate BEF switch positions, corresponding to "unused" functions, are illustrated in the function diagrams, Section 10.1.

If several inputs (terminal(s) and/or bit(s) of the control word and/or of the freely-definable control word) are assigned the same binary input function, then the control inputs involved are logically combined (e.g. "disconnect voltage (low active)" function is logically AND'd, also refer to the table in Section 10.5.2).

**List of the binary input functions (BEF)**, which can be assigned a binary select input terminal (terminals 39, 40, 41, 42, 43, 36).

Most of these functions can be also assigned a STWF bit (also refer to the table in Section 10.5.2).

A detailed description of each of the individual functions is provided from Section 10.3.1 onwards, whereby the final digit of the section number coincides with the number of the particular binary input function so that it can be easily found. The functions have been described for using binary select terminals as control inputs, but the same is essentially valid for control via STWF bits).

|    |  |             |
|----|--|-------------|
| 0  | No function  |             |
| 1  | Reserved for later use   |             |
| 2  | Shutdown button (low active)   | from SW2.00 |
| 3  | Voltage disconnect (OFF2) (low active)                                 |             |
| 4  | Fast stop (OFF3) (low active)  |             |
| 5  | Fault acknowledgement  |             |
| 6  | Enable technology controller   | from SW1.10 |
| 7  | Enable speed controller  |             |
| 8  | Enable EMF controller  |             |
| 9  | Ramp-function generator enable   |             |
| 10 | Ramp-function generator stop   |             |
| 11 | Setpoint enable  |             |
| 12 | Wobulation enable (oscillation)  | from SW2.00 |
| 13 | Inching  |             |
| 14 | Inching and bypass ramp-function generator                             |             |
| 15 | Crawl  |             |
| 16 | Crawl and bypass ramp-function generator                               |             |
| 17 | Fixed setpoint   |             |
| 18 | Fixed setpoint and bypass ramp-function generator                      |             |
| 19 | Supplementary setpoint before the technology controller                | from SW1.10 |
| 20 | Supplementary setpoint before the ramp-function generator              |             |
| 21 | Supplementary setpoint before the speed controller                     |             |
| 22 | Supplementary setpoint before torque limiting                          |             |
| 23 | Supplementary setpoint before the current controller                   |             |
| 24 | Setpoint reduction (P315, P316, P319, P320)                            |             |
| 25 | Motorized potentiometer, manual/automatic (switch)                     | from SW1.10 |
| 26 | Motorized potentiometer, raise setpoint                                | from SW1.10 |
| 27 | Motorized potentiometer, lower setpoint                                | from SW1.10 |
| 28 | Motorized potentiometer, clockwise/counter-clockwise rotation (switch) | from SW1.10 |
| 29 | Motorized potentiometer, clockwise rotation (button)                   | from SW1.10 |
| 30 | Motorized potentiometer, counter-clockwise rotation (button)           | from SW1.10 |
| 31 | Ramp-function generator setting 2 (P307 to P310)                       |             |
| 32 | Ramp-function setting 3 (P311 to P314)                                 |             |
| 33 | Use parameter set 2  | from SW2.00 |
| 34 | Use parameter set 3  | from SW2.00 |
| 35 | Use parameter set 4  | from SW2.00 |
| 36 | Enable the technology controller, droop                                | from SW1.10 |
| 37 | Enable the speed controller, droop                                     | from SW1.10 |
| 38 | Enable signal for changeover PI/P speed controller                     |             |
| 39 | Enable signal for dv/dt switch-in                                      | from SW1.10 |
| 40 | Speed controller actual value polarity reversal                        |             |
| 41 | Changeover, master/slave drive   |             |
| 42 | Changeover, torque limiting  |             |

|    |  |             |
|----|--|-------------|
| 43 | Switch-in analog input "main setpoint" (terminals 4 and 5)   |             |
| 44 | Switch-in analog input "main actual value" (terminals XT-101 to XT-103)                                    |             |
| 45 | Switch-in analog input "select input analog 1" (terminals 6 and 7)   |             |
| 46 | Switch-in analog input "select input analog 2" (terminal 8)  |             |
| 47 | Switch-in analog input "select input analog 3" (terminal 10)   |             |
| 48 | Sign, analog input "main setpoint" (terminals 4 and 5)   |             |
| 49 | Sign, analog input "main actual value" (terminals XT-101 to XT-103)  |             |
| 50 | Sign, analog input "select input analog 1" (terminals 6 and 7)   |             |
| 51 | Sign, analog input "select input analog 2" (terminal 8)  |             |
| 52 | Sign, analog input "select input analog 3" (terminal 10)   |             |
| 53 | External fault (low active). Delay time, which can be set with P767, until the fault signal has responded. |             |
| 54 | External alarm (low active)  |             |
| 55 | Checkback signal "line contactor switched-in"  |             |
| 56 | Standstill field   |             |
| 57 | Direction of rotation reversal by field reversal   | from SW2.00 |
| 58 | Braking with field reversal  | from SW2.00 |
| 59 | $I_{\text{field external}} < I_{f_{\text{min}}}$ (low active)  |             |
| 60 | Enabling a torque direction for torque direction change for a parallel drive configuration                 | from SW2.00 |
| 61 | Set binary select output 1, if P771 = 2  | from SW1.10 |
| 62 | Set binary select output 2, if P772 = 2  | from SW1.10 |
| 63 | Set binary select output 3, if P773 = 2  | from SW1.10 |
| 64 | Set binary select output 4, if P774 = 2  | from SW1.10 |
| 65 | Changeover free changeover switch 1  | from SW2.00 |
| 66 | Changeover free changeover switch 2  | from SW2.00 |
| 67 | Changeover free changeover switch 3  | from SW2.00 |
| 68 | Set motorized potentiometer  | from SW2.00 |



10.3.1 Reserved for later use

### 10.3.2 Shutdown button (low active) from SW2.00

This binary input function (BEF2) is selected with setting 2 of the particular select parameter (also refer to Section 10.3.90 and P769 in Section 9.2).

This function is only effective for parameter P769 = 1 (edge-triggering of the "switch-on" and "crawl" functions)

Level: 0 "Switch-on" and "crawl" not possible.  
 1 "Switch-on" and "crawl" possible for a positive edge (signal level change 0 → 1) at a "switch-on" input (terminal 37 or bit 0 from STW), and at an input, parameterized as "crawl" (select terminal or STWF).

A negative edge (signal level 1 → 0) results in "shutdown".

### 10.3.3 Voltage disconnect (OFF2) (low active)

This binary input function (BEF3) is selected with setting 3 of the particular select parameter.

The control of the "voltage disconnect (low active)" function can be realized from the select terminals, from STWF, and from bit 1 of STW.

From SW2.00, by parameterizing P067 = 2, the 0 button on the operator control panel can be assigned the "voltage disconnect (low active)" function

Level: 0 Voltage disconnect  
 1 (not used) No voltage disconnect

#### Sequence when entering the voltage disconnect command:

1. Enter the "voltage disconnect" command
2. Inhibit the technology controller, ramp-function generator, speed- and current controllers
3.  $I_{set} = 0$  is entered
4. The pulses are inhibited when  $I = 0$
5. Output "close operating brake" signal (BAF14 = 0, for P080 = 2) from SW2.00
6. Operating status o10.0 or higher is reached
7. Enter a field current actual value which existed shortly before OFF2 (K265) as field current setpoint upper limit ("release" is realized for operating status  $\leq$  o5)
8. The "line contactor in" relay drops out
9. The drive coasts down (or is braked by the operating brake)
10. Delay time which can be parameterized (P258) expires
11. The field is reduced to a value which can be parameterized (P257)
12. If  $n < n_{min}$  (P370, P371) is reached, the "close holding brake" signal is output (BAF14 = 0, for P080 = 1) from SW1.20

#### Sequence when the voltage disconnect command is withdrawn:

1. Withdraw "voltage disconnect" command
  2. Operating status o10 is exited
- All "voltage disconnect" commands, (e.g. from terminals, control words etc.) are logically AND'd by the SIMOREG converter, i.e., all commands must be at "no voltage disconnect" so that the "voltage disconnect" function is ineffective.

### 10.3.4 Fast stop (OFF3) (low active)

This binary input function (BEF4) is selected with setting 4 of the particular select parameter (also refer to Section 10.1 Sheets 6, 15, 17, 18).

The "fast stop (low active)" function can be controlled from the select terminals, from STWF and from bit 2 of STW.

From software release 2.00 onwards, with the parameterization  $P067 = 3$ , the 0 button of the operator control panel can be assigned the "fast stop (low active)" function.

Level: 0                      Fast stop  
           1 (not used)        No fast stop

#### Sequence when entering "fast stop":

1. Enter the "fast stop" command (e.g. via the "fast stop" terminal)
2. Technology controller and ramp-function generator are inhibited
3. Enter  $n_{set} = 0$
4. Decelerate along the current limit
5. Wait until  $n < n_{min}$  (P370, P371)
6. Output "close operating or holding brake" signal (BAF14 = 0)
7. Wait for the brake closing time (P088)
8. Enter  $I_{set} = 0$
9. Technology controller, ramp-function generator and speed controller are inhibited
10. The pulses are inhibited if  $I = 0$
11. The "line contactor in" relay drops out
12. Operating status o9.0 or higher is reached
13. Delay time for field current reduction (P087) expires
14. The field is reduced to a value P257 which can be parameterized

#### Sequence when withdrawing "fast stop":

1. Withdraw "fast stop" command
2. Enter "shutdown" command (e.g. via "switch-on/shutdown" terminal)
3. Operating status o8 is exited

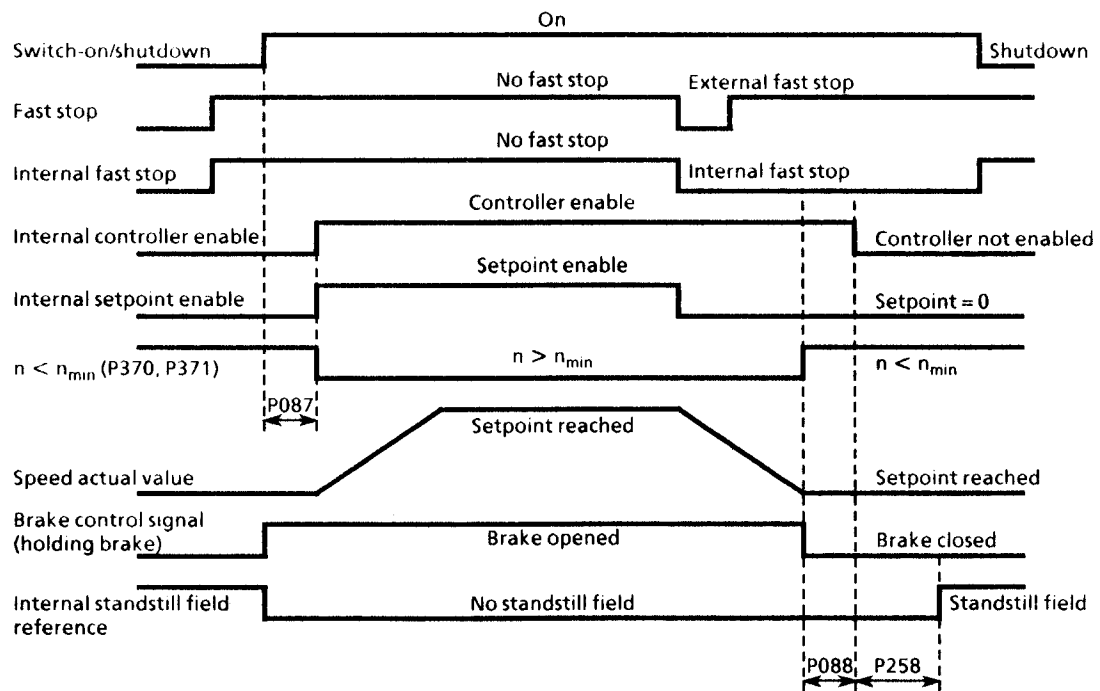

- P087 Brake release time (in this case positive)  
 P088 Brake closing time  
 P258 Delay time for automatic field current reduction

- The "fast stop" command must only be available as short pulse ( $> 10$  ms). It is then internally stored. This memory can be reset by entering the "shutdown" command.
- All "fast stop" commands (e.g. from terminals, control words etc.) are logically AND'd by the SIMOREG converter i.e. all commands must be at "no fast stop", so that the "fast stop" function is ineffective.
- When  $n < n_{min}$  (P370, P371) is reached for the first time, an internal interlocking function is effective, which prevents the drive attempting to brake again if the motor is turned by an external force so that the  $n < n_{min}$  signal disappears again.
- from SW 2.00  
In order that "fast stop" functions for current- or torque lower limits, even with different connections (P600 to P649 changed), and when injecting supplementary setpoints, when "fast stop" is entered, specific functions become automatically ineffective. While braking until  $n < n_{min}$ , all torque limits are ineffective. Only the system current limit (P171 and P172), the speed-dependent current limit as well as the current limit from the I<sup>2</sup>t monitoring of the power section are effective from all of the current limits.

For more information, refer to function diagrams, Section 10.1:

- 0% setpoint becomes effective after P608 (Sheet 15)
- K147 becomes effective directly after K133 (Sheet 17)
- P603 and P604 are ineffective (Sheet 17)
- P600 is ineffective (Sheet 18)
- Master/slave changeover and P084 are bypassed, i.e. closed-loop speed control is selected (Sheet 15)

### 10.3.5 Fault acknowledgement (as supplied, terminal 36)

This binary input function (BEF5) is selected with setting 5 of the particular select parameter.

The "fault acknowledgement" function can be activated from the select terminals, from STWF and from bit 7 of the STW.

Signal level: Positive edge (signal must be present for at least 10 ms)  
acknowledges the fault

A fault is acknowledged by a positive edge (corresponds to depressing the SELECT key on the simple operator control panel or the R key on the operator control panel).

The further sequence is described in Section 8.2.3 "acknowledging fault messages".

If several inputs are parameterized as "fault acknowledge", the function is executed by the rising edge at one of the terminals.

### 10.3.6 Enable technology controller

from SW1.10

This binary input function (BEF6) is selected with setting 6 of the particular select parameter (also refer to Section 10.1, Sheet 10).

Signal level: 0 Technology controller inhibited  
1 (not used) Technology controller enabled

If several inputs are parameterized as "enable technology controller", all terminals must be energized, so that the technology controller is enabled. The controller is always inhibited, independent of the enable signal, in all operating statuses  $\geq 01.0$ .

### 10.3.7 Enable speed controller

This binary input function (BEF7) is selected with setting **7** of the particular select parameter (also refer to Section 10.1 Sheet 15).

Signal level: 0                      Inhibit speed controller  
                   1 (not used)      Enable speed controller

If several inputs are parameterized as "enable speed controller", all terminals must be energized so that the speed controller is enabled. In all operating statuses  $\geq 01.0$ , the controller is always inhibited, independent of the enable signal. The integrator is set to the value according to parameter P220, when the speed controller is inhibited.

### 10.3.8 Enable EMF controller

This binary input function (BEF8) is selected with setting **8** of the particular select parameter (also refer to Section 10.1, Sheet 19).

Signal level: 0                      EMF controller inhibited  
                   1 (not used)      EMF controller enabled

If several inputs are parameterized as "enable EMF controller", all terminals must be energized, so that the EMF controller is enabled.

### 10.3.9 Ramp-function generator enable

This binary input function (BEF9) is selected with setting **9** of the particular select parameter (also refer to Section 10.1 Sheet 14).

This function can be controlled from the select terminals, from STWF or from bit 4 of the STW.

Signal level: 0                      Ramp-function generator is inhibited  
                   1 (not used)      Ramp-function generator is enabled

If a terminal is parameterized as "ramp-function generator enable", then the ramp-function generator is enabled when the terminal is energized.

If the terminal, parameterized as "ramp-function generator enable" is opened, the ramp-function generator is inhibited, the ramp-function generator output becomes 0, the drive decelerates along the current limit and the converter is not disconnected or isolated from the supply.

When the ramp-function generator is re-enabled, it ramps-up to the setpoint along the selected ramp.

If several inputs are parameterized as "enable ramp-function generator" all inputs must be energized, so that the ramp-function generator is enabled.

### 10.3.10 Ramp-function generator stop

This binary input function (BEF10) is selected with setting **10** of the particular select parameter (also refer to Section 10.1, Sheet 14).

This function can be controlled from the select terminals, from STWF or from bit 5 of STW (Caution: When controlled from STW.5, inverted logical signal level).

Signal level: 0 (not used)      Ramp-function generator enabled  
                   1                              Ramp-function generator stop

If a terminal is parameterized as "ramp-function generator stop", when the terminal is energized ramp-up is interrupted and the ramp-function generator output is held at the instantaneous value.

When the terminal is opened, the ramp-function generator output is enabled, and the ramp-function generator continues to ramp with the selected ramp-up or ramp-down time.

If several inputs are parameterized as "ramp-function generator stop" only one input must be energized so that the ramp-function generator is stopped.

### 10.3.11 Setpoint enable

This binary input function (BEF11) is selected with setting **11** of the particular select parameter (also refer to Section 10.1, Sheet 12).

This function is controlled from the select terminals, from STWF or from bit 6 of STW.

|               |              |                  |
|---------------|--------------|------------------|
| Signal level: | 0            | Inhibit setpoint |
|               | 1 (not used) | Enable setpoint  |

If a terminal is parameterized as "setpoint enable" when the terminal is energized, the external setpoint at the ramp-function generator input is switched through.

When the terminal is opened, the external setpoint is switched-out, internal setpoints and supplementary setpoints remain active.

If several inputs are parameterized as "setpoint enable" all inputs must be energized so that the external setpoints are switched through.

### 10.3.12 Wobulation enable (oscillation)

from SW2.00

This binary input function (BEF12) is selected with setting **12** of the particular select parameter (also refer to Section 10.1, Sheet 12).

|               |              |   |
|---------------|--------------|---|
| Signal level: | 0 (not used) | Oscillation off, the operationally entered setpoint is switched-through                             |
|               | 1            | Oscillation on, the square-wave signal (oscillation setpoint) available at K208 is switched-through |

If several inputs are parameterized as "oscillation", when one of the inputs is energized, the oscillation setpoint is switched-in.

The oscillation setpoint setting using parameters P480 to P483 and the mode of operation can be taken from Section 10.1, Sheet 12.

### 10.3.13 Inching

This binary input function (BEF13) is selected with setting **13** of the particular select parameter (also refer to Section 10.1, Sheet 12).

|               |              |            |
|---------------|--------------|------------|
| Signal level: | 0 (not used) | No inching |
|               | 1            | Inching    |

Each of the digital select inputs can be parameterized as "inching". The associated inching setpoint is stored in parameters P401 "digital setpoint 1" to P406 "digital setpoint 6".

When this function is requested via the freely-definable control word STWF, the value at parameter P409 is used as inching setpoint.

The "inching" function is only possible if "shutdown" and "operating enable" are entered.

#### Sequence when selecting inching:

If a terminal, parameterized as "inching" is energized, the line contactor is switched-in through the "line contactor on" relay, and the inching setpoint is switched-in via the ramp-function generator (sequence, refer to "switch-on/shutdown", according to Section 10.3.90).

**Sequence when withdrawing inching:**

If all of the terminals, which are parameterized as "inching" are opened, the sequence starts just like the "shutdown" function (refer to Section 10.3.90). When  $n < n_{min}$  is reached, the controller is inhibited, and after a time which can be parameterized (P085) from 0 to 60 s, the line contactor is switched-out (operating status o7.0 or higher). The drive remains in operating status o1.3, during the sequence up to a maximum delay time, which can be parameterized, of 60.0s, according to P085.

If two terminals, parameterized as "inching" are simultaneously energized, 0 is applied as inching setpoint.

**10.3.14 Inching and bypass ramp-function generator**

This binary input function (BEF14) is selected with setting 14 of the particular select parameter (also refer to Section 10.1 Sheet 12).

|               |              |            |
|---------------|--------------|------------|
| Signal level: | 0 (not used) | No inching |
|               | 1            | Inching    |

Each of the digital select inputs can be parameterized as "inching and bypass ramp-function generator". The associated inching setpoint is stored in parameters P401 "digital setpoint 1" to P406 "digital setpoint 6".

The value at parameter P410 is used as setpoint, when this function is requested via the freely-definable control word STWF.

Functions the same as "inching", however only operational as long as the command is present, the ramp-function generator with ramp-up time = ramp-down time = 0.

**10.3.15 Crawl**

This binary input function (BEF15) is selected with setting 15 of the particular select parameter (also refer to Section 10.1 Sheet 12).

|               |              |          |
|---------------|--------------|----------|
| Signal level: | 0 (not used) | No crawl |
|               | 1            | Crawl    |

Each of the digital select inputs can be parameterized as "crawl".

The associated crawl setpoint is stored in parameters P401 "digital setpoint 1" to P406 "digital setpoint 6".

When this function is requested via the freely-definable control word STWF, the value at parameter P411 is used as crawl setpoint.

The "crawl" function is possible in operating status o7 and in the "run" status with "operating enable".

**Sequence when selecting crawl:**

If a terminal, parameterized as "crawl" is energized in operating status o7, the line contactor is switched-in through the "line contactor in" relay, and the crawl setpoint is applied via the ramp-function generator.

If one of the terminals, parameterized as "crawl" is energized in the "run" status, the drive decelerates down from the operating speed to the crawl setpoint via the ramp-function generator.

**Sequence when withdrawing crawl:**

For "crawl", if the "switch-on" command is not present:

If all of the terminals, parameterized as "crawl" are opened, the controller is inhibited after  $n < n_{min}$  has been reached, and the line contactor switched-out (operating status o7.0 or higher).

For "crawl" from the "run" operating status:

If all of the terminals, parameterized as "crawl", are opened, and if the conditions for the "run" mode are still present, the drive accelerates from the selected crawl speed to the operating speed via the ramp-function generator.

If several terminals, parameterized as "crawl" are simultaneously energized, the setpoints, set at the parameters, are added.

from SW 2.00

If the "crawl" function is parameterized for edge triggering (refer to P769 in Section 9.2), then a select terminal for a bit of the freely-definable control word STWF must be assigned the binary input function "shutdown button" (low active) (BEF2).

The signal level change (LOW → HIGH) at the "crawl" input only results in crawl, if the input, parameterized as "shutdown button" (low active) has a "HIGH" signal level at the same time. For edge triggering, automatic restart, and the effect of current- and torque limits when braking, also refer to Section 10.3.90 (switch-on/shutdown).

### 10.3.16 Crawl and bypass ramp-function generator

This binary input function (BEF16) is selected with setting **16** of the particular select parameter (also refer to Section 10.1, Sheet 12).

|               |              |          |
|---------------|--------------|----------|
| Signal level: | 0 (not used) | No crawl |
|               | 1            | Crawl    |

Every digital select input can be parameterized as "crawl and bypass ramp-function generator". The associated inching setpoint is stored in parameters P401 "digital setpoint 1" to P406 "digital setpoint 6".

When this function is requested via the freely-definable control word STWF, the value at parameter P412 is used as setpoint.

Functions like "crawl" however it only operates as long as the command is available, and the ramp-function generator is set for ramp-up time = ramp-down time = 0.

### 10.3.17 Fixed setpoint

This binary input function (BEF17) is selected with setting **17** of the particular select parameter (also refer to Section 10.1, Sheet 12).

|               |              |                               |
|---------------|--------------|-------------------------------|
| Signal level: | 0 (not used) | Main setpoint is used         |
|               | 1            | Fixed setpoint is switched-in |

The "fixed setpoint" function is possible in the "run" status for "controller enable".

#### Sequence when entering a supplementary setpoint:

If one or several terminals (max. 6) are parameterized as "fixed setpoint", when one of the terminals is energized, the main setpoint is switched-out, and the value set at the setpoint parameter (P401 to P406) is switched-in. When this function is requested via the freely-definable control word STWF, the setpoint from parameter P413 is switched-in.

If several terminals, parameterized as "fixed setpoint" are simultaneously energized, the setpoints set at the parameters are added.

#### Sequence when withdrawing the fixed setpoint:

If all of the terminals, parameterized as "fixed setpoint", are opened, the main setpoint is used.

### 10.3.18 Fixed setpoint and bypass ramp-function generator

This binary input function (BEF18) is selected with setting **18** of the particular select parameter (also refer to Section 10.1, Sheet 12).

Signal level: 0 (not used) Main setpoint is used  
1 Fixed setpoint is switched-in

Functions like "fixed setpoint" however it only operates as long as the command is present, and the ramp-function generator is set with ramp-up time = ramp-down time = 0.

The setpoint from P414 is switched-in when requested via STWF.

### 10.3.19 Supplementary setpoint before the technology controller from SW1.10

This binary input function (BEF19) is selected with setting **19** of the particular select parameter (also refer to Section 10.1, Sheet 10).

Signal level: 0 (not used) No supplementary setpoint  
1 Supplementary setpoint is switched-in

The "supplementary setpoint" function is possible in the "run" status for "controller enable".

**Sequence when entering a supplementary setpoint:**

If one or several terminals (max. 6) are parameterized as "supplementary setpoint before the technology controller", when a terminal is energized the value set at the setpoint parameter (P401 to P406) is added to the technology controller setpoint.

The value from parameter P415 is added when this function is requested via the freely-definable control word STWF.

If several terminals, parameterized as "supplementary setpoint before the technology controller" are simultaneously energized, the setpoints, set at the parameters are added

### 10.3.20 Supplementary setpoint before the ramp-function generator

This binary input function (BEF20) is selected with setting **20** of the particular select parameter (also refer to Section 10.1, Sheet 12).

Signal level: 0 (not used) No supplementary setpoint  
1 Supplementary setpoint is switched-in

The "supplementary setpoint" function is possible in the "run" status for "operating enable".

**Sequence when entering a supplementary setpoint:**

If one or several terminals (max. 6) are parameterized as "supplementary setpoint before the ramp-function generator", when a terminal is energized, the value, set at the setpoint parameter (P401 to P406) is added to the main setpoint.

When this function is requested via the freely-definable control word STWF, the value from parameter P416 is added.

If several terminals, which are parameterized as "supplementary setpoint before the ramp-function generator" are simultaneously energized, the setpoints set at the parameters are added.



### 10.3.21 Supplementary setpoint before the speed controller

This binary input function (BEF21) is selected with setting 21 of the particular select parameter (also refer to Section 10.1, Sheet 14).

Signal level: 0 (not used) No supplementary setpoint  
1 Supplementary setpoint is switched-in

The "supplementary setpoint" function is possible in the "run" status for "controller enable".

#### Sequence when entering a supplementary setpoint:

If one or several terminals (max. 6) are parameterized as "supplementary setpoint before the speed controller", when a terminal is energized, the value set at the setpoint parameter (P401 to P406) is added to the ramp-function generator output.

When this function is requested via the freely-definable control word STWF, the value from parameter P417 is added.

If several terminals, parameterized as "supplementary setpoint before the speed controller" are simultaneously energized, the setpoints set at the parameters are added.

### 10.3.22 Supplementary setpoint before torque limiting

This binary input function (BEF22) is selected with setting 22 of the particular select parameter (also refer to Section 10.1, Sheet 15).

Signal level: 0 (not used) No supplementary setpoint  
1 Supplementary setpoint is switched-in

The "supplementary setpoint" function is possible in the "run" status for controller enable".

#### Sequence when entering a supplementary setpoint:

If one or several terminals (max. 6), are parameterized as "supplementary setpoint before torque limiting", when a terminal is energized, the value set at the setpoint parameters (P401 to P406) is added to the speed controller output.

When this function is requested via the freely-definable control word STWF, the value from parameter P418 is added.

If several terminals, which are parameterized as "supplementary setpoint before torque limiting" are simultaneously energized, the setpoint, set at the parameters, are added.

### 10.3.23 Supplementary setpoint before the current controller

This binary input function (BEF23) is selected with setting 23 of the particular select parameter (also refer to Section 10.1, Sheet 17).

Signal level: 0 (not used) No supplementary setpoint  
1 Supplementary setpoint is switched-in

The "supplementary setpoint" function is possible in the "run" status for "controller enable".

#### Sequence when entering a supplementary setpoint:

If one or several terminals (max. 6) are parameterized as "supplementary setpoint before the current controller", when a terminal is energized, the value set at the setpoint parameter (P401 to P406) is added to the current setpoint (before current limiting). When this function is requested via the freely-definable control word STWF, the value from parameter P419 is added.

If several terminals, which are parameterized as "supplementary setpoint before the current controller" are simultaneously energized, the setpoints, set at the parameters are added.

**10.3.24 Setpoint reduction**

This binary input function (BEF24) is selected with setting **24** of the particular select parameter (also refer to Section 10.1, Sheet 13).

Signal level: 0 (not used) The speed limiting for the ramp-function generator input P315, P316 is effective  
1 Speed setpoint reduction P319, P320 are effective

The "supplementary setpoint" function is possible in the "run" status for "controller enable".

**Sequence when selecting setpoint reduction:**

If terminals are parameterized as "setpoint reduction", when a terminal is energized, a changeover is made from parameters P315 (positive limit for the ramp-function generator input), and P316 (negative limit for the ramp-function generator input) to parameter P319 (speed setpoint reduction, positive direction) and P320 (speed setpoint reduction, negative direction).

**10.3.25 Motorized potentiometer, manual/automatic (switch) from SW1.10**

This binary input function (BEF25) is selected with setting **25** of the particular select parameter (also refer to Section 10.1, Sheet 11).

Signal level: 0 (not used) Mot. potentiometer, manual (raise/lower key effective)  
1 Mot. potentiometer, automatic (setpoint is input acc. to P461)

If several inputs are parameterized as "motorized potentiometer, manual/automatic", then automatic operation is effective when one of the terminals is energized.

**10.3.26 Motorized potentiometer, raise setpoint from SW1.10**

This binary input function (BEF26) is selected with setting **26** of the particular select parameter (also refer to Section 10.1, Sheet 11).

Signal level: 0 (not used) Motorized potentiometer setpoint is not increased  
1 Motorized potentiometer setpoint is increased

If several inputs are parameterized as "motorized potentiometer, raise", when one of the terminals is energized, the motorized potentiometer setpoint is increased.

**10.3.27 Motorized potentiometer, lower setpoint from SW1.10**

This binary input function (BEF27) is selected with setting **27** of the particular select parameter (also refer to Section 10.1, Sheet 11).

Signal level: 0 (not used) Motorized potentiometer setpoint is not lowered  
1 Motorized potentiometer setpoint is lowered

If several inputs are parameterized as "motorized potentiometer, lower", when one of the terminals is energized, the motorized potentiometer setpoint is lowered.  
"Lower setpoint" has priority over "raise setpoint".

**10.3.28 Motorized potentiometer, clockwise/counter-clockwise (switch) from SW1.10**

This binary input function (BEF28) is selected with setting **28** of the particular select parameter (also refer to Section 10.1, Sheet 11).

Signal level: 0 (not used) Mot. potentiometer setpoint is positive (clockwise direction)  
1 Mot. potentiometer setpoint is negative (counter-clockwise direction)

If several inputs are parameterized as "motorized potentiometer, clockwise/counter-clockwise", when one of the terminals is energized, the motorized potentiometer setpoint is negative.

### 10.3.29 Motorized potentiometer, clockwise (pushbutton) from SW1.10

This binary input function (BEF29) is selected with setting 29 of the particular select parameter (also refer to Section 10.1, Sheet 11).

This function cannot be controlled from STWF.

Signal level: 0 (not used) Existing motorized potentiometer setpoint polarity is retained  
1 Motorized potentiometer setpoint polarity is positive (clockwise)

If several inputs are parameterized as "motorized potentiometer, clockwise", when one of the terminals is energized, the motorized potentiometer setpoint is positive.

If one input is parameterized as "motorized potentiometer, clockwise (pushbutton)" or as "motorized potentiometer, counter-clockwise (pushbutton)", all inputs, parameterized as "motorized potentiometer, clockwise/counter-clockwise" are ineffective.

### 10.3.30 Motorized potentiometer, counter-clockwise (pushbutton) from SW1.10

This binary input function (BEF30) is selected with setting 30 of the particular select parameter (also refer to Section 10.1, Sheet 11)

This function cannot be controlled from the STWF.

Signal level: 0 (not used) Existing motorized potentiometer setpoint polarity is retained  
1 Motorized potentiometer setpoint polarity is negative (counter-clockwise)

If several inputs are parameterized as "motorized potentiometer, counter-clockwise", when one of the terminals is energized, the motorized potentiometer setpoint is negative.

If one input is parameterized as "motorized potentiometer, clockwise (pushbutton)" or as "motorized potentiometer, counter-clockwise (pushbutton)", all inputs, parameterized as "motorized potentiometer, clockwise/counter-clockwise" are ineffective.

### 10.3.31 Ramp-function generator, setting 2 (P307 to P310)

This binary input function (BEF31) is selected with setting 31 of the particular select parameter (also refer to Section 10.1, Sheet 14).

Signal level: 0 (not used) Ramp-function generator set 1 is used: P303, P304, P305, P306  
1 Ramp-function generator parameter set 2: P307, P308, P309, P310

If a terminal is parameterized as "ramp-function generator- setting 2", when the terminal is energized, ramp-function generator- parameter set 2 is selected. The function has priority over the settings at parameter P302 ("ramp-up integrator").

If several inputs are parameterized as "ramp-function generator-setting 2", when a terminal is energized, ramp-function generator - parameter set 2 is selected.

The converter trips with fault F041, if "ramp-function generator-setting 2" and "ramp-function generator-setting 3" are both energized.

### 10.3.32 Ramp-function generator, setting 3 (P311 to P314)

This binary input function (BEF32) is selected with setting 32 of the particular select parameter (also refer to Section 10.1 Sheet 14).

|               |              |   |
|---------------|--------------|---|
| Signal level: | 0 (not used) | Ramp-function generator set 1 is used: P303, P304, P305, P306           |
|               | 1            | Ramp-function generator parameter set 3 is used: P311, P312, P313, P314 |

If a terminal is parameterized as "ramp-function generator- setting 3", when the terminal is energized, ramp-function generator- parameter set 3 is selected. The function has priority over the settings at parameter P302 (ramp-up integrator).

If several inputs are parameterized as "ramp-function generator-setting 3", when a terminal is energized, ramp-function generator- parameter set 3 is selected.

The converter trips with fault F041, if "ramp-function generator-setting 2" and "ramp-function generator-setting 3" are both energized.

### 10.3.33, .34, .35 Use parameter set 2, 3, 4

from SW2.00

This binary input function (BEF33, BEF34, BEF35) is selected with setting 33, 34, 35 of the particular select parameter.

|                                    |                                      |
|------------------------------------|--------------------------------------|
| BEF33 = 0, BEF34 = 0 and BEF35 = 0 | Use parameter set 1 (P100 to P599)   |
| BEF33 = 1                          | Use parameter set 2 (2P100 to 2P599) |
| BEF34 = 1                          | Use parameter set 3 (3P100 to 3P599) |
| BEF35 = 1                          | Use parameter set 4 (4P100 to 4P599) |

From BEF33, BEF34 and BEF35 only one single function can have a logical 1, otherwise fault message F041 is output after 0.5 s. The last clearly identified parameter set is still used while the status is not completely clear.

Warning:

The parameter set selection must remain the same during optimization runs. Fault message F041 is output, if the logical signal level BEF33, BEF34 or BEF35 changes for longer than 0.5s during an optimization run.

A delay of up to 25 ms can occur between this function being activated, until the appropriate parameter set becomes effective.

When parameterizing, the following should be observed, in conjunction with the "use parameter set 2 (or 3 or 4)" function:

Each parameter value change, which was made in a specific set, must also be made in all sets which are used, if a different function is not requested for the parameter involved in the applicable sets. This is especially valid for several (for space reasons) selection parameters in the parameter range P100 to P599, or parameters which are used to define a mode (e.g. settings for the motorized potentiometer, for master/slave drive etc.)

The parameter set changeover is also effective online. Thus, it is possible, to changeover gains etc. online. However, for parameters with different values in various sets, it should be carefully considered, whether it is really practical to make online changes. For specific parameters (especially for offline parameters), unpredictable operating statuses can occur, if, due to online changeover of the parameter set, different set values of this parameter can be accessed.



**WARNING**



Some important parameters which define the closed-loop control structure and the converter functions, lie in the range, which are involved in the parameter set changeover (e.g. settings for the motorized potentiometer, master/slave drive etc.). The following procedure is strongly recommended in order to eliminate any undesirable structure- or function changes when changing parameter sets, which could lead to dangerous operating conditions: Make a basic setting in a "basis" parameter set, copy this in the parameter sets still to be used, and only then parameterize the required differences to the "basis" parameter set in the applicable parameter set.

Note:

Parameter P054 is only used to select the parameter set to be displayed (1, 2, 3 or 4). The actually used parameter set (1, 2, 3 or 4) is defined by the function described above, and indicated at parameter P056.

Parameter P055 allows parameter set 1, 2, 3 or 4 to be copied to parameter set 1, 2, 3 or 4, and the contents of two parameter sets to be interchanged.

### 10.3.36 Enable technology controller droop from SW1.10

This binary input function (BEF36) is selected with setting **36** of the particular select parameter (also refer to Section 10.1, Sheet 10).

The "droop" function is described in Section 9.2 (parameter description) under parameter P427.

|                 |                        |
|-----------------|------------------------|
| Signal level: 0 | Droop is not effective |
| 1 (not used)    | Droop is effective     |

If none of the terminals is parameterized as "enable technology controller droop" the feedback is always effective (disabled using parameter P427 = 0).

If several inputs are parameterized as "enable technology controller droop", droop is always effective when one of the terminals is energized.

### 10.3.37 Enable speed controller droop from SW1.10

This binary input function (BEF37) is selected with setting **37** of the particular select parameter (also refer to Section 10.1, Sheet 15).

The "enable speed controller droop" function is described in Section 9.2 (Parameter description) under parameter P227.

|                 |                        |
|-----------------|------------------------|
| Signal level: 0 | Droop is not effective |
| 1 (not used)    | Droop is effective     |

If none of the terminals are parameterized as "enable speed controller droop", droop is always effective (disabled using parameter P227 = 0).

If several inputs are parameterized as "enable speed controller droop", droop becomes effective when all of the terminals are energized.

### 10.3.38 Enable changeover, P/PI speed controller

This binary input function (BEF38) is selected with setting **38** of the particular select parameter (also refer to Section 10.1 Sheet 15).

Signal level: 0 Changeover, PI/P speed controller is not effective  
1 (not used) Changeover, PI/P speed controller is effective

If a terminal is parameterized as "enable P/PI speed controller changeover", then the speed-dependent changeover from PI to P controller is effective, depending on the terminal signal status (the threshold can be set at parameter P222).

If several inputs are parameterized as "enable changeover, PI/P speed controller", the changeover is effective if all inputs are energized.

### 10.3.39 Enable dv/dt input

from SW1.10

This binary input function (BEF39) is selected with setting **39** of the particular select parameter (also refer to Section 10.1 Sheet 16).

Signal level: 0 "Moment of inertia compensation" (= dv/dt input) is not effective  
1 (not used) "Moment of inertia compensation" (= dv/dt input) is effective

If several inputs are parameterized as "enable dv/dt input", all terminals must be energized so that dv/dt input is effective.

### 10.3.40 Speed controller actual value polarity reversal

This binary input function (BEF40) is selected with setting **40** of the particular select parameter (also refer to Section 10.1, Sheet 15).

Signal level: 0 (not used) Actual value polarity is not inverted  
1 The actual value at the speed controller input is inverted

If several inputs are parameterized as "speed controller actual value polarity reversal", the polarity reversal is effective when one of the terminals is energized.

### 10.3.41 Master/slave changeover

This binary input function (BEF41) is selected with setting **41** of the particular select parameter (also refer to Section 10.1, Sheet 15).

Refer to P229 in Section 9.2 regarding the speed controller mode for slave operation.

Signal level: 0 (not used) Master drive  
1 Slave drive (the torque setpoint comes from a source defined by P500)

If several inputs are parameterized as "master/slave drive changeover", the slave drive mode is selected when one of the inputs is energized.

If the "peer-to-peer" bus communications (P780 or P790 = xxx4) is activated, this function also defines whether the RS232 interface operates as sender or receiver (also refer to Section 10.7.4.2).

Signal level: 0 The send component of the RS485 interface drives the "peer-to-peer" bus,  
the receive component of the RS485 interface is inactive.  
1 The send line of the RS485 interface is in a high-ohmic state,  
the receive component of the RS485 interface is active.

The binary input function "changeover, master/slave drive (BEF41), allows, together with the "peer-to-peer" bus protocol, a multi-motor drive to be implemented, where several drives operate on the same shaft. Any particular drive is the "master drive", and all other drives are "slave drives". Any slave drive can be disabled using the "shutdown" or "fast stop" command, by withdrawing "controller enable" or also by simply withdrawing the bus cable. All drives receive the speed setpoint.

- One drive (any drive) can be selected as the "master drive" with BEF41 = 0. This drive is then speed controlled. The RS485 interface send line (transmit line) is switched-through to the "peer-to-peer" bus. The RS485 interface receiver is inactive.
- All other drives, must be switched to "slave drive" by BEF41 = 1. Every slave drive is operated, either in the closed-loop current or torque controlled mode. The current/torque setpoint is received from the speed controller output of the master drive via the "peer-to-peer" bus. The send line of the RS485 interface is in the high-ohmic condition. The RS485 interface receiver is active.

If the drive operating as "master drive" is to be changed to "slave drive" and another drive should become the "master drive", then the "old" master drive should first be changed-over to "slave drive" and then, within 0.5s, the "new" master drive is then changed-over from "slave drive" to "master drive". This procedure eliminates that on one hand, the transmit components of two drives operate briefly against each other, and on the other hand that no fault message is output, as no valid telegram can be received from slave drives.

Parameterization:

|               |  |
|---------------|--|
| P780 = xxx4   | "Peer-to-peer" bus protocol at G-SST0                                  |
| P783 = 10     | 187.5 kbyte or another baud rate                                       |
| P500 = 20     | 1st receive data at G-SST0 is used as current/torque setpoint          |
| P784.00 = 147 | Torque setpoint is sent to GSST0 as 1st process data                   |
| P761 = 41     | Terminal #39 is assigned the "changeover, master/slave drive" function |

### 10.3.42 Torque limit changeover

This binary input function (BEF42) is selected with setting **42** of the particular select parameter (also refer to Section 10.1, Sheet 17).

The "torque limit changeover" function is described in Section 9.2 (parameter description) under parameter P184.

|                            |   |
|----------------------------|---|
| Signal level: 0 (not used) | The torque limit is not changed-over (P180 and P181 are effective).   |
| 1                          | The torque limit is changed-over if the speed is greater than the changeover speed selected with parameter P184. Parameters 182 and P183 are effective as torque limit. |

If several inputs are parameterized as "torque limit changeover", when one of the terminals is energized, the torque limit changeover becomes effective.

### 10.3.43 Switching-in analog input "main setpoint" (terminals 4 and 5)

This binary input function (BEF43) is selected with setting **43** of the particular select parameter (also refer to Section 10.1 Sheet 2).

|                 |   |
|-----------------|---|
| Signal level: 0 | The switch is open.                                     |
| 1 (not used)    | The switch is closed, the main setpoint is switched-in. |

If several inputs are parameterized as "switch-in main setpoint (terminals 4 and 5), all terminals must be energized so that the setpoint is switched through.

**10.3.44 Switch-in the "main actual value" analog input (terminals 101, 102 and 103)**

This binary input function (BEF44) is selected with setting **44** of the particular select parameter (also refer to Section 10.1, Sheet 2).

Signal level: 0                      The switch is open.  
                   1 (not used)      The switch is closed, the main actual value is switched-in.

If several inputs are parameterized as "switch-in main actual value (terminals 101, 102 and 103), all terminals must be energized so that the actual value is switched through.

**10.3.45 Switch-in the "select input, analog 1", analog input (terminals 6 and 7)**

This binary input function (BEF45) is selected with setting **45** of the particular select parameter (also refer to Section 10.1, Sheet 2).

Signal level: 0                      The switch is open.  
                   1 (not used)      The switch is closed, select input analog 1 is switched-in.

If several inputs are parameterized as "switch-in select input, analog 1 (terminals 6 and 7)", all terminals must be energized so that the select input is switched through.

**10.3.46 Switch-in "select input, analog 2" analog input (terminal 8)**

This binary input function (BEF46) is selected with setting **46** of the particular select parameter (also refer to Section 10.1, Sheet 2).

Signal level: 0                      The switch is open.  
                   1 (not used)      The switch is closed, select input analog 2 is switched-in.

If several inputs are parameterized as "switch-in select input, analog 2 (terminal 8)" all terminals must be energized so that the select input is switched through.

**10.3.47 Switch-in "select input, analog 3" analog input (terminal 10)**

This binary input function (BEF47) is selected with setting **47** of the particular select parameter (also refer to Section 10.1, Sheet 2).

Signal level: 0                      The switch is open.  
                   1 (not used)      The switch is closed, select input analog 3 is switched-in.

If several inputs are parameterized as "switch-in select input, analog 3 (terminal 10)", all terminals must be energized so that the select input is switched through.

**10.3.48 "Main setpoint" analog input polarity (terminals 4 and 5)**

This binary input function (BEF48) is selected with setting **48** of the particular select parameter (also refer to Section 10.1, Sheet 2).

Signal level: 0 (not used)      The polarity is not changed.  
                   1                              The main setpoint polarity is inverted.

If several inputs are parameterized as "main setpoint polarity (terminals 4 and 5)", the main setpoint is inverted when one terminal is energized.



### 10.3.49 "Main actual value" analog input polarity (terminals 101, 102 and 103)

This binary input function (BEF49) is selected with setting 49 of the particular select parameter (also refer to Section 10.1, Sheet 2).

Signal level: 0 (not used) The polarity is not changed.  
1 The main actual value polarity is inverted.

If several inputs are parameterized as "polarity, main actual value (terminals 101, 102 and 103)", when a terminal is energized, the main actual value is inverted.

### 10.3.50 "Select input analog 1" analog input polarity (terminals 6 and 7)

This binary input function (BEF50) is selected with setting 50 of the particular select parameter (also refer to Section 10.1, Sheet 2).

Signal level: 0 (not used) The polarity is not changed.  
1 The polarity of select input, analog 1 is inverted.

If several inputs are parameterized as "polarity, select input analog 1 (terminals 6 and 7)", the select input is inverted when a terminal is energized.

### 10.3.51 "Select input analog 2" analog input polarity (terminal 8)

This binary input function (BEF51) is selected with setting 51 of the particular select parameter (also refer to Section 10.1, Sheet 2).

Signal level: 0 (not used) The polarity is not changed.  
1 The polarity of select input, analog 2 is inverted.

If several inputs are parameterized as "polarity, select input analog 2 (terminal 8)", the select input is inverted when a terminal is energized.

### 10.3.52 "Select input analog 3" analog input polarity (terminal 10)

This binary input function (BEF52) is selected with setting 52 of the particular select parameter (also refer to Section 10.1, Sheet 2).

Signal level: 0 (not used) The polarity is not changed.  
1 The polarity of select input, analog 3 is inverted.

If several inputs are parameterized as "polarity, select input analog 3 (terminal 10)", the select input is inverted when a terminal is energized.

### 10.3.53 External fault (low active)

This binary input function (BEF53) is selected with setting 53 of the particular select parameter (also refer to Section 8.2.2.8 "external faults").

This function cannot be controlled from the STWF.

The external fault is handled just like an internal fault. Fault messages F121 to F126 are initiated, dependent on the parameterized terminal.

The fault message is only activated, if the appropriate terminal is set to LOW, for at least the time set at parameter P767.

Signal level: 0 Fault message is activated  
1 (not used) Fault message is not activated

### 10.3.54 External alarm (low active)

This binary input function (BEF54) is selected with setting **54** of the particular select parameter (also refer to Section 8.3.2).

This function cannot be controlled from the STWF.

The external alarm is handled just like an internal alarm. Alarm numbers W21 to W26 are activated, dependent on the parameterized terminal.

|                 |                        |
|-----------------|------------------------|
| Signal level: 0 | Alarm is activated     |
| 1 (not used)    | Alarm is not activated |

### 10.3.55 Operating enable due to the checkback signal "line contactor in"

This binary input function (BEF55) is selected with setting **55** of the particular select parameter.

It is used to evaluate an auxiliary contact of the line contactor.

Using this function, operation is only enabled, when the line contactor has pulled-in (checkback signal from the auxiliary contact).

|                 |  |
|-----------------|--|
| Signal level: 0 | No operating enable, operating status $\leq 0.6$ cannot be reached, as the line contactor has not pulled-in. |
| 1 (not used)    | Operating status $0.6$ can be exited, as the line contactor has pulled-in.                                   |

If several inputs are parameterized as "checkback signal, line contactor in", all terminals must be energized so that operating status  $0.6$  can be exited.

### 10.3.56 Standstill excitation

This binary input function (BEF56) is selected with setting **56** of the particular select parameter (also refer to Section 10.3.92).

### 10.3.57 Direction of rotation reversal using field reversal from SW2.00

This binary input function (BEF57) is selected with setting **57** of the particular select parameter (also refer to Section 10.4.30 (BAF30) and 10.4.31 (BAF31)).

The binary input function "direction of rotation reversal using field reversal" (BEF57) has a switch function, and defines the field direction and with a positive speed setpoint, also the direction of rotation.

|                 |  |
|-----------------|--|
| Signal level: 0 | Positive field direction is selected<br>("field contactor 1 in" (BAF30) = 1, "field contactor 2 in" (BAF31) = 0) |
| 1               | Negative field direction is selected<br>("field contactor 1 in" (BAF30) = 0, "field contactor 2 in" (BAF31) = 1) |

A change in the logical level of the binary input function "direction of rotation reversal using field reversal" (BEF57) brakes the drive and accelerates it in the opposite direction of rotation as a result of an internal sequence.

During field reversal, BEF57 is ineffective, i.e. once field reversal has been started, it is completed. Only after field reversal has been realized, is a check made as to whether the logical level of BEF57 coincides with the selected field direction.

Note:

Only positive speed setpoints are practical.

**Control sequence when entering "direction of rotation reversal with field reversal":**

1. Drive rotates in direction 1 (or is at standstill)
2. The binary input function "direction of rotation reversal by field reversal" changes its logical status
3. Internal field reversal sequence (only if braking was not previously initiated by the pushbutton "braking with field reversal" (BEF58):
  - 3.1 Internal (armature) "operating enable for field reversal" = 0 means that the drive waits until armature current  $I_A = 0$  and the armature pulses are inhibited (drive then remains in operating status  $\geq o1.4$ )
  - 3.2 "Pulse inhibit, field" = 1
  - 3.3 Wait for  $I_{field} < I_{field\ min}$  (P394)
  - 3.4 Delay time according to P092 (0.0 to 3.0s)
  - 3.5 The actual field contactor is opened (BAF30 = 0 or BAF31 = 0)
  - 3.6 100ms delay time
  - 3.7 The new field contactor is energized (BAF31 = 1 or BAF30 = 1)
  - 3.8 The speed actual value polarity is reversed (except for P083 = 3 ... EMF as speed actual value)
  - 3.9 "Pulse inhibit, field" = 0 (field pulse enable)
  - 3.10 Delay until  $I_{field} > 50\% I_{field\ set}$
  - 3.11 Internal (armature) "operating enable for field reversal" = 1 (drive shutdown is cancelled in operating status  $\geq o1.4$ )
4. The drive brakes, and then rotates in direction 2 (or is stationary)

**10.3.58 Braking with field reversal****from SW2.00**

This binary input function (BEF58) is selected with setting **58** of the particular select parameter (also refer to Sections 10.4.30 (BAF30) and 10.4.31 (BAF31)).

The binary input function "braking with field reversal" (BEF58) has a pushbutton function.

If the logical level of the binary input function "braking with field reversal" BEF58 = 1 (for at least 30 ms), in operating status  $\leq o5$  (line contactor closed), the drive is internally braked down to  $n < n_{min}$ . After this, the original field direction is selected.

It is only possible to re-accelerate in the original direction of rotation after first removing the braking command (BEF58 = 0), and acknowledging using "shutdown" and "switch-on".

**Control sequence when entering "braking with field reversal":**

1. The drive rotates in direction of rotation 1
2. Binary input function "braking with field reversal" = 1 for longer than 30 ms
3. Internal field reversal (only if the line contactor is switched-in) (for operating status  $\leq o5$ ) and the drive isn't already braking. Braking is identified by a negative internal actual speed (whereby this is obtained for the negative field direction by inverting the actual speed):
  - 3.1 Internal (armature) "operating enable for field reversal" = 0, means that the drive waits until the armature current  $I_A = 0$  and the armature pulses are inhibited (drive then stays in operating status  $\geq o1.4$ )
  - 3.2 "Pulse inhibit, field" = 1
  - 3.3 Wait for  $I_{field} < I_{field\ min}$  (P394)
  - 3.4 Delay time according to P092 (0.0 to 3.0s)
  - 3.5 The actual field contactor is opened (BAF30 = 0 or BAF31 = 0)
  - 3.6 100ms delay time
  - 3.7 The other field contactor is energized (BAF31 = 1 or BAF30 = 1)
  - 3.8 The speed actual value polarity is reversed (except for P083 = 3 ... EMF as speed actual value)
  - 3.9 "Pulse inhibit, field" = 0 (field pulse enable)
  - 3.10 Delay until  $I_{field} > 50\% I_{field\ set}$
  - 3.11 Internal (armature) "operating enable for field reversal" = 1 (drive shutdown is cancelled in operating status  $\geq o1.4$ )

4. Internal sequence to brake the drive:
  - 4.1 When the "internal shutdown" command is internally entered:  
 $n_{set} = 0$  is internally entered at the ramp-function generator input,  
 Wait for  $n < n_{min}$  (P370),  
 wait until the armature current  $I_A = 0$ , and then armature pulse inhibit  
 (drive then goes into operating status o7.2)
  - 4.2 Wait until operating status  $\geq o7$  has been reached, and then command "internal shutdown" is continually entered to prevent the drive accelerating in the opposite direction of rotation (acknowledgement using an external "shutdown" and "switch-on")
  - 4.3 Wait until the braking command is removed with BEF58 = 0 (as long as BEF58 = 1, the drive is kept in operating status o7.2)
5. Internal sequence for changing over to the original field direction (only then, if the actual field direction does not coincide with that requested using the input function "direction of rotation reversal with field reversal" (BEF57):
  - 5.1 Internal (armature) "operating enable for field reversal" = 0 means that the drive waits until armature current  $I_A = 0$ , and the armature pulses are inhibited.  
 (drive remains in operating status  $\geq o1.4$ )
  - 5.2 "Pulse inhibit, field" = 1
  - 5.3 Wait for  $I_{field} < I_{field\ min}$  (P394)
  - 5.4 Delay time according to P092 (0.0 to 3.0s)
  - 5.5 The actual field contactor is opened (BAF31 = 0 or BAF30 = 0)
  - 5.6 100ms delay time
  - 5.7 The new field contactor is energized (BAF31 = 1 or BAF30 = 1)
  - 5.8 The speed actual value polarity is reversed (except for P083 = 3 ... EMF as speed actual value)
  - 5.9 "Pulse inhibit, field" = 0 (field pulse enable)
  - 5.10 Wait for  $I_{field} > 50\% I_{field\ set}$
  - 5.11 Internal (armature) "operating enable for field reversal" = 1  
 (drive shutdown is cancelled in the operating status  $\geq o1.4$ )
6. The drive is in operating status o7.2  
 The drive can accelerate in the original direction of rotation by acknowledging using an external "shutdown" and "switch-on"

### 10.3.59 $I_{field\ external} < I_{f\ min}$ (low active)

This binary input function (BEF59) is selected with setting 59 of the particular select parameter.

It is used to evaluate an external field current monitoring function and has the same effect as the internal converter field current monitoring (i.e. with the command "switch-on", in operating status o5.0, the drive waits, for a maximum time according to P089, for the message " $I_{field\ external} > I_{f\ min}$ " and when the " $I_{field\ external} < I_{f\ min}$ " message is present in operation, (BEF59 = 0) fault message F005 is issued 500ms after the time according to P086 has expired).

|                 |                                    |
|-----------------|------------------------------------|
| Signal level: 0 | $I_{field\ external} < I_{f\ min}$ |
| 1 (not used)    | $I_{field\ external} > I_{f\ min}$ |

If several inputs are parameterized as " $I_{field\ external} < I_{f\ min}$ ", all terminals must be energized so that  $I_{field\ external} > I_{f\ min}$  is identified.

### 10.3.60 Enabling a torque direction for torque direction change for a parallel drive configuration from SW2.00

This binary input function (BEF60) is selected with setting **60** of the particular select parameter (also refer to Section 10.1, Sheet 18 and 10.4.32).

|               |   |   |
|---------------|---|---|
| Signal level: | 0 | A torque direction change from M I to M II is permitted, but a torque direction change from M II to M I is prevented, and results in no torque direction being selected ( -- ). |
|               | 1 | A torque direction change from M II to M I is permitted, but a torque direction change from M I to M II is prevented, and results in no torque direction being selected ( -- ). |

When this function is used, a torque direction change requested by this converter (i.e. by selecting a new torque direction M I or M II after the current has decayed in the previously selected torque direction M II or M I, and after a possibly parameterized no-current interval has expired, according to parameter P160), is inhibited by extending the no-current interval (i.e. no torque direction ( -- ) selected), until the required torque direction of this converter coincides with the torque direction of the parallel drive (BEF60), signaled at the input. If there is no internal request to select a new torque direction (same polarity from K119), then the actually selected torque direction M I, M II or no ( -- ) is not changed by the input signal level of the input parameterized as BEF 60.

In conjunction with the binary output function "signaling the torque direction" (BAF32) (refer to Section 10.4.32), this function allows this converter to be connected in parallel with another 6RA24 converter (when using coupling reactors).

"12-pulse operation" can be used, if the two 6RA24 converters are supplied with two supply voltages, phase-shifted through 30 degrees. This has the advantage of lower motor current ripple. Both converters control the converter current and conduct half the motor current. One converter is the master converter, and operates in the closed-loop speed control mode, and outputs its own current setpoint as current setpoint for the slave drive (K119). Torque direction change is only possible by mutually interlocking with BEF60 and BAF 32. The current setpoint and the BEF60/BAF32 signals (STWF/ZSW2) can be transferred via a "peer-to-peer" coupling (also refer to Section 10.7.4).

The torque-free interval at torque direction change is, under certain circumstances, somewhat longer than for 6-pulse drives due to each converter having to wait until the other 6RA24 converter is ready.

Only one input may be assigned this function.

### 10.3.61 Set binary select output 1 from SW1.10

This binary input function (BEF61) is selected with setting **61** of the particular select parameter (also refer to Section 10.1, Sheet 4).

This function is only effective, if binary select output 1 is not assigned any function, i.e. if P771 = 2.

|               |   |  |
|---------------|---|--|
| Signal level: | 0 | Binary select output 1 (terminal 46) is set to logical 0 |
|               | 1 | Binary select output 1 (terminal 46) is set to logical 1 |

If several inputs are parameterized as "set binary select output 1", select output 1 is set to logical 1 when one of the terminals is energized.

**10.3.62 Set binary select output 2****from SW1.10**

This binary input function (BEF62) is selected with setting **62** of the particular select parameter (also refer to Section 10.1, Sheet 4).

This function is only effective, if binary select output 1 is not assigned any function, i.e. if P772 = 2.

|               |   |  |
|---------------|---|--|
| Signal level: | 0 | Binary select output 2 (terminal 48) is set to logical 0 |
|               | 1 | Binary select output 2 (terminal 48) is set to logical 1 |

If several inputs are parameterized as "set binary select output 2", select output 2 is set to logical 1 when one of the terminals is energized.

**10.3.63 Set binary select output 3****from SW1.10**

This binary input function (BEF63) is selected with setting **63** of the particular select parameter (also refer to Section 10.1, Sheet 4).

This function is only effective, if binary select output 1 is not assigned any function, i.e. if P773 = 2.

|               |   |  |
|---------------|---|--|
| Signal level: | 0 | Binary select output 3 (terminal 50) is set to logical 0 |
|               | 1 | Binary select output 3 (terminal 50) is set to logical 1 |

If several inputs are parameterized as "set binary select output 3", select output 3 is set to logical 1 when one of the terminals is energized.

**10.3.64 Set binary select output 4****from SW1.10**

This binary input function (BEF64) is selected with setting **64** of the particular select parameter (also refer to Section 10.1, Sheet 4).

This function is only effective, if binary select output 1 is not assigned any function, i.e. if P774 = 2.

|               |   |  |
|---------------|---|--|
| Signal level: | 0 | Binary select output 4 (terminal 52) is set to logical 0 |
|               | 1 | Binary select output 4 (terminal 52) is set to logical 1 |

If several inputs are parameterized as "set binary select output 4", select output 4 is set to logical 1 when one of the terminals is energized.

**10.3.65 Changeover command for the free changeover switch 1****from SW2.00**

This binary input function (BEF65) is selected with setting **65** of the particular select parameter (also refer to Section 10.1, Sheet 8).

|               |              |   |
|---------------|--------------|---|
| Signal level: | 0 (not used) | Switch-through connector K243                   |
|               | 1            | Switch-through the connector selected with P657 |

**10.3.66 Changeover command for the free changeover switch 2****from SW2.00**

This binary input function (BEF66) is selected with setting **66** of the particular select parameter (also refer to Section 10.1, Sheet 8).

|               |              |   |
|---------------|--------------|---|
| Signal level: | 0 (not used) | Switch-through connector K235                   |
|               | 1            | Switch-through the connector selected with P667 |

### 10.3.67 Changeover command for the free changeover switch 3 from SW2.00

This binary input function (BEF67) is selected with setting **67** of the particular select parameter (also refer to Section 10.1, Sheet 8).

Signal level: 0 (not used) Switch-through connector K155  
1 Switch-through the connector selected with P677

### 10.3.68 Set motorized potentiometer from SW2.00

This binary input function (BEF68) is selected with setting **68** of the particular select parameter (also refer to Section 10.1, Sheet 11).

Signal level: 0 (not used) Motorized potentiometer is not influenced  
1 The motorized potentiometer output is set to the value, of the connector selected using parameter P466.

### 10.3.69 to 10.3.89 reserved

### 10.3.90 Switch-on/shutdown (ON/OFF) terminal 37

(also refer to Section 10.1, Sheet 6, 14, 15, 17, 18)

The "switch-on/shutdown" (ON/OFF) function can be controlled from terminal 37 and bit 0 of the STW.

From SW2.00 the function can also be parameterized for "edge triggering" refer below).

Signal level: 0 Shutdown  
1 Switch-on

from SW2.00

Instead of terminal 37, the I key on the operator control panel can also be used to control the "switch-on" function. The function of the I key can be defined using P066:

P066 = 0 The I key has no function.  
P066 = 1 The I key has the "switch-on" function. Terminal 37 on the converter is ineffective.  
P066 = 2 The I key has the function "switch-on" and "operating enable". Terminals 37 and 38 on the converter are ineffective.

from SW2.00

With the parameterization P067 = 1, the 0 key of the operator control panel can be assigned the "shutdown" function.

**Sequence when switching-in the drive:**

1. Enter the "switch-on" command (e.g. via the "switch-on/shutdown" terminal)
  2. Operating status o7 is exited
  3. The "line contactor in" relay pulls-in
  4. Field current reduction is cancelled
- if "operating enable" is present:
5. for a positive brake opening time (P087) output the "open holding for operating brake" signal (BAF14 = 1) and wait in operating status o1.0, P087, for a negative brake opening time (P087 negative), proceed immediately to step 6, brake remains closed (BAF14 = 0)
  6. Technology controller, ramp-function generator, speed and current controllers are enabled
  7. After a negative brake opening time has expired (P087), output "open holding or operating brake" signal (BAF14 = 1)

### Sequence when shutting down the drive:

1. Enter the "shutdown" command (e.g. via the "switch-on/shutdown" terminal)
2. The drive decelerates along the ramp-function generator ramp
3. Wait until  $n < n_{min}$  (P370, P371)
4. Issue the "close holding or operating brake" signal (BAF14 = 0)
5. Wait for the brake closing time (P088)
6. Enter  $i_{set} = 0$
7. Technology controller, ramp-function generator and speed controller are inhibited
8. When  $i = 0$ , the pulses are inhibited
9. The "line contactor in" relay drops-out
10. Operating status 07.0 or higher is reached
11. Delay time for field current reduction (P258) expires
12. The field is reduced to a value which can be parameterized (P257)

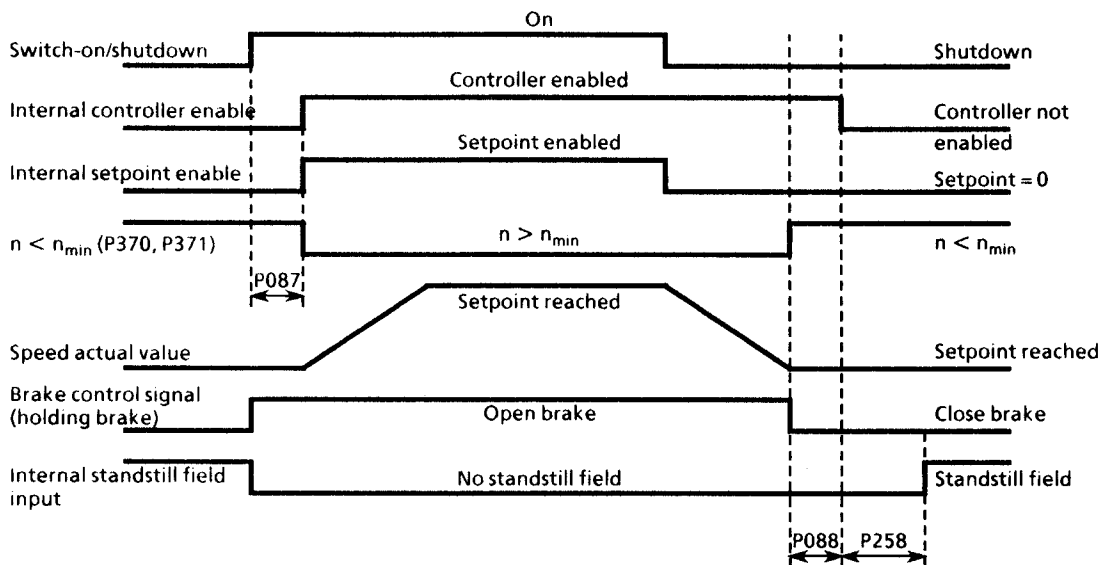

- P087 Brake opening time (in this case positive)  
 P088 Brake closing time  
 P258 Delay time for automatic field current reduction

- When the "shutdown" command is entered, setpoint limiting at the speed controller input is ineffective (the ramp-function generator output is fed-in after P608, refer to Section 10.1, Sheet 14).
- An internal interlocking function becomes effective the first time that  $n < n_{min}$  (P370, P371) which prevents the drive from braking again, if the motor is rotated due to an external force, so that the  $n < n_{min}$  signal disappears again.
- All "switch-on/shutdown" commands (e.g. from terminals, control words etc.), are logically AND'd by the SIMOREG converter i.e., all commands must be at "switch-on", so that the "switch-on function" is again effective.
- from SW2.00  
 If the "switch-on" function (terminal 37 or control word STW, bit 0) is parameterized for edge triggering (refer to P769 in Section 9.2), a select terminal, or a bit of the freely-definable control word STWF must be assigned the binary input function "shutdown pushbutton (low active)" (BEF2).  
 The signal change (LOW → HIGH) at the "switch-on" input only starts the drive if the signal level of the input, parameterized as "shutdown button" is "HIGH".



- Re-parameterization between level- or edge triggering is effective for "switch-on", "shutdown" and "crawl".
- For edge triggering, automatic restart is not possible for brief electronic power supply failures.
- Specific functions are automatically ineffective if "shutdown" is entered, so that "shutdown" still functions, even when new connections are made (P600 to P649 changed), if lower current- or torque limits are entered, and when injecting supplementary setpoints. All torque limits are ineffective during braking to  $n < n_{min}$ . From the current limits, only the system current limit (P171 and P172), the speed-dependent current limit as well as the current limit resulting from the power section I<sup>2</sup>t monitoring function are effective.

For more detailed information, refer to the function diagrams, Section 10.1:

- K190 acts directly after P608 (Sheet 15)
- K147 acts directly after K133 (Sheet 17)
- P603 and P604 are ineffective (Sheet 17)
- P600 is ineffective (Sheet 18)

### 10.3.91 Operating enable (OPER. ENAB.) terminal 38

The "operating enable" function can be controlled from terminal 38 or from bit 3 of the STW (also refer to Section 10.1, Sheet 6).

from SW2.00

For parameterization P066 = 2, terminal 38 of the converter is ineffective, and the I key of the operator control panel has, in this case, the "switch-on" and "operating enable" functions.

|                 |                     |
|-----------------|---------------------|
| Signal level: 0 | No operating enable |
| 1               | Operating enable    |

Sequence when entering operating enable (if a switch-on command is present):

1. Enter the "operating enable" command
2. For a positive brake opening time (P087), output the "open holding- or operating brake" signal (BAF14 = 1), and wait in operating status o1.0, P087, for a negative brake opening time (P087 negative), progress immediately to step 3, the brake remains closed (BAF14 = 0).
3. Technology controller, ramp-function generator, speed controller and I controller are enabled.
4. Operating status I, II or -- is reached
5. After a negative brake opening time has expired (P087), the "open holding- or operating brake" signal (BAF14 = 1) is output.

Sequence when withdrawing the operating enable signal:

1. Withdraw the operating enable command
  2. Inhibit technology controller, ramp-function generator, speed controller and current controller
  3.  $I_{set} = 0$  is entered
  4. The pulses are inhibited when  $I = 0$
  5. The "close operating brake" signal (BAF14, for P080 = 2) is output from SW2.00
  6. Operating status o1.0 or higher is reached
  7. Drive coasts down (or is braked by the operating brake)
  8. If  $n < n_{min}$  (P370, P371) is reached, the "close holding brake" signal is output (BAF14, for P080 = 1) from SW1.20
- All "operating enable" commands (e.g. from terminals, control words etc.) are logically AND'd by the SIMOREG converter, i.e. all commands must be at "operating enable", so that the "operating enable" function is effective.

### 10.3.92 Field current reduction (standstill excitation)

(also refer to Section 10.1, Sheet 20)

#### a) Automatic field current reduction

The function is activated via parameter P082 "operating mode for the field" (P082 = xx2).

**Sequence when shutting down the drive:**

1. Enter the "shutdown" command (e.g. via the "switch-on/shutdown" terminal)
2. Operating status o7.0 or higher is reached
3. Delay time (P258) which can be parameterized expires
4. The field is reduced to a value (P257) which can be parameterized

**Sequence when switching-on the drive:**

1. Enter the "switch-on" command (e.g. via the "switch-on/shutdown" terminal)
2. Operating status o7 is exited
3. Field current reduction is cancelled

#### b) Signal-controlled field current reduction

This binary input function (BEF56) is selected with setting 56 of the particular select parameter (also refer to Section 10.1, Sheet 20).

|                           |                  |
|---------------------------|------------------|
| Signal level:0 (not used) | Standard field   |
| 1                         | Standstill field |

The field is immediately reduced to a value which can be parameterized (P257) by entering the command "standstill field" (e.g. via a binary select input).

Exception: The "standstill field" command is not effective during an optimization run.

### 10.3.93 Safety shutdown (E-STOP)

#### a) Switch operation

(Switch between terminals XS-105 and XS-106; XS-107 open; XS-108 open)  
Safety shutdown is initiated by opening the switch.

#### b) Pushbutton operation

(Stop pushbutton with normally closed contact between terminals XS-107 and XS-106;  
reset pushbutton with normally open contact between terminals XS-108 and XS-106; XS-105 open)

Stop pushbutton depressed; safety shutdown is realized and stored.

Reset pushbutton depressed; safety shutdown (stored) is cancelled.

**Sequence when entering E-STOP :**

1. Enter the "E-STOP" command
2. Inhibit the technology controller, ramp-function generator, speed- and current controllers
3.  $I_{set} = 0$  is entered
4. The pulses are inhibited when  $I = 0$
5. "Close operating brake" signal is output (BAF14, for P080 = 2) from SW2.00
6. Operating status o10.0 or higher is reached
7. Enter a field current actual value which existed several computation cycles prior to this (K265) as field current setpoint upper limit ("release" is realized for operating status  $\leq o5$ )
8. "Line contactor in" relay drops out
9. The drive coasts down or is braked by the operating brake
10. Delay time (P258) which can be parameterized expires
11. The field is reduced to a value (P257) which can be parameterized
12. When  $n < n_{min}$  (P370, P371) is reached, the "close holding brake" signal is output (BAF14, for P080 = 1) from SW1.20

**Comment:**

"E-Stop" acts like "disconnect voltage" ("OFF2"), and the line contactor is tripped from the hardware side 15 ms after this command has been entered (via relay K1).

## 10.4 Binary output functions

The binary output functions can be switched to the following terminals

- 46 (select output, binary 1) with parameter P771
- 48 (select output, binary 2) with parameter P772
- 50 (select output, binary 3) with parameter P773
- 52 (select output, binary 4) with parameter P774.

The selected function can be inverted using P770.

Further, for terminals 46, 48, 50 and 52, a delay time can be parameterized (parameters P775 to P778). The logical level at the particular binary select output is only changed, if the internal level of the selected delay time remains constant (internal level changes, which are shorter than this time, are not switched-through to the output).

- 0 Logical "0"
- 1 Logical "1"
- 2 Logical "0" or according to binary input function 61, 62, 63, 64
- 3 Fault (low active)
- 4 Ready to switch-on (operating status o7)
- 5 Ready (operating status o1)
- 6 Run (operating status I, II or --)
- 7 Auxiliaries ON from SW2.00
- 8 Supply voltage present (armature and field)
- 9 Line contactor control OFF (= switch-on inhibit) (low active)
- 10 Line contactor OFF (= E-Stop) (low active)
- 11 Checkback signal of the binary input function BEF55 "line contactor in" (low active)
- 12 Ramp-function generator active
- 13 Counter-clockwise direction of rotation (hysteresis, P396)
- 14 Switch-on command for the holding- or operating brake (low active)
- 15  $I_A > I_x$  ( $I_x$  is set with P391, hysteresis P392)
- 16  $n < n_{base} = n_{x1}$  ( $n_{x1}$  is set with P373, hysteresis, P374)
- 17  $n < n_{x2}$  ( $n_{x2}$  is set with P376, hysteresis, P377)
- 18  $n < n_{x3}$  ( $n_{x3}$  is set with P379, hysteresis, P380)
- 19  $n < n_{x4}$  ( $n_{x4}$  is set with P382, hysteresis, P383)
- 20  $n < n_{x5}$  ( $n_{x5}$  is set with P385, hysteresis, P386)
- 21  $n < n_{min}$  ( $n_{min}$  is set with P370, hysteresis, P371)
- 22  $n_{set}$  reached signal (speed controller setpoint-actual value difference  $<$  P362, time according to P363)
- 23  $n < n_{excess}$  ( $n_{excess}$  is set with P354, time according to P363)
- 24 Alarm (low active)
- 25 Alarm "motor overload" i.e. W01 or W05 or W06 (low active)
- 26 Alarm "converter overload", i.e. W10 (low active)
- 27 Converter cooling faulted (also refer to fault signal, signal also comes when the fault signal is suppressed) (low active)
- 28  $I_{field} < I_{f_{min}}$  (low active) ( $I_{f_{min}}$  is set with P394, hysteresis P395)
- 29  $I_{Aset} = I_{limit}$  (actual current limit reached)
- 30 Field contactor 1 ON for field reversal from SW2.00
- 31 Field contactor 2 ON for field reversal from SW2.00
- 32 Torque direction change signal changed from SW2.00
- 33 Power section hot
- 34 Output of the freely-configurable limit value monitor 1 (function according to P692) from SW2.00
- 35 Output of the freely-configurable limit value monitor 2 (function according to P694) from SW2.00

Note:

Most of these output functions are available at status words (ZSW (K325), ZSW1 (K326) and ZSW2 (K327) (also refer to Section 10.1, Sheet 4 and 10.6). For several output functions, the logical signal level specified in the following does not coincide with the logical signal level of the appropriate bits in the status words.

Fig. 1: Status description of the binary outputs

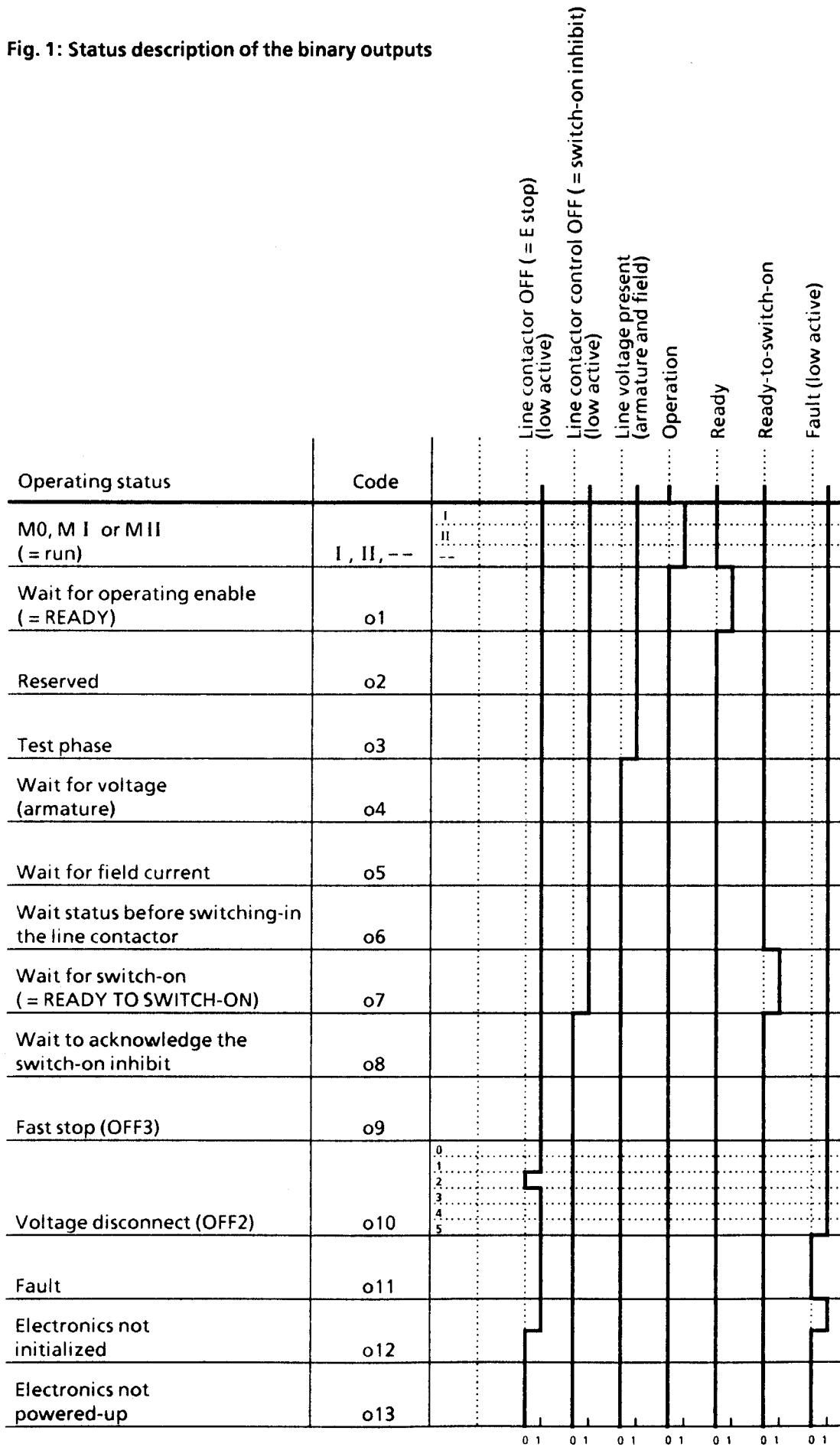

### 10.4.3 Fault (low active)

The function is parameterized, when supplied, at the "select output binary 1" output (terminal 46).

The function can be parameterized at select outputs "select output binary 1" (terminal 46) to "select output binary 4" (terminal 52) with setting 3 of the particular select parameter.

Signal level: 0 Fault, the drive is in operating status o11.  
1 No fault

Function: Refer to Section 10.4, Fig. 1 (status description, binary outputs)

Note:

The "fault" status bit of the status word (ZSW.3), has the inverted logical signal level to BAF3 (refer to Section 10.6.1).

### 10.4.4 Ready to switch-on (operating status o7)

The function can be parameterized at the select outputs "select output binary 1" (terminal 46) to "select output binary 4" (terminal 52) with setting 4 of the particular select parameter.

Signal level: 0 The drive is in an operating status other than o7.  
1 Ready-to-switch-on; the drive is in operating status o7. The power supply is switched-on, electronics initialized, line contactor de-energized, pulses inhibited, no "switch-on inhibit", wait for "switch-on", "inching" or "crawl".

Function: Refer to Section 10.4, Fig. 1 (status description, binary outputs)

### 10.4.5 Ready (operating status o1)

The function can be parameterized at the select outputs "select output binary 1" (terminal 46) to "select output binary 4" (terminal 52) with setting 5 of the particular select parameter.

Signal level: 0 The drive is in an operating status other than o1.  
1 Ready; the drive is in operating status o1. The line contactor is closed, wait for "operating enable".

Function: Refer to Section 10.4, Fig. 1 (status description, binary outputs)

### 10.4.6 Run (operating status I , II or --)

The function can be parameterized at the select outputs "select output binary 1" (terminal 46) to "select output binary 4" (terminal 52) with setting 6 of the particular select parameter.

Signal level: 0 The drive is in an operating status other than I , II or --.  
1 Run, the drive is in operating statuses I , II or --.

Function: Refer to Section 10.4, Fig. 1 (status description, binary outputs)

**10.4.7 Switch-on auxiliaries****from SW2.00**

This function serves as switch-on command for the auxiliaries (e.g. motor fan). The "switch-on auxiliaries" signal goes to high with the "switch-on" command. After this, the drive goes into operating status o6.0 for a time which can be parameterized (P093). The line contactor is only closed when this time has expired.

When the "shutdown" command is input, the firing pulses are inhibited, and the line contactor drops-out after  $n < n_{min}$ . The "switch-on auxiliaries" signal goes to low after a time (P094) which can be parameterized. However, if the "switch-on" command is entered before this time expires, the drive does not remain in operating status o6.0, and the line contactor is immediately closed.

Signal level: 0 Switch-out auxiliaries  
1 Switch-in auxiliaries

**10.4.8 Supply voltage (armature and field)**

The function can be parameterized at the select outputs "select output binary 1" (terminal 46) to "select output binary 4" (terminal 52) with setting 8 of the particular select parameter.

Signal level: 0 The drive is in operating status  $\geq o4$ .  
1 Supply voltage (armature and field) present, the drive is in an operating status  $< o4$ .

Function: Refer to Section 10., Fig. 1 (Status description, binary outputs)

**10.4.9 Line contactor control OFF (= switch-on inhibit) (low active)**

The function can be parameterized at the select outputs "select output binary 1" (terminal 46) to "select output binary 4" (terminal 52) with setting 9 of the particular select parameter.

Signal level: 0 The converter was isolated from the supply by the electronics for safety reasons,  
(operating statuses  $\geq o8$ ) "switch-on inhibit" is active  
1 The line contactor can be switched-in via the converter control.

Function: Refer to Section 10., Fig. 1 (Status description, binary outputs)

Note:

The status bit "switch-on inhibit" of the status word (ZSW.6) has the inverted signal logic level with respect to BAF9 (refer to Section 10.6.1).

**10.4.10 Line contactor OFF (= E stop) (low active)**

The function can be parameterized at the select outputs "select output, binary 1" (terminal 46) to "select output, binary 4" (terminal 52) with setting 10 of the particular select parameter.

Signal level: 0 Safety shutdown (E stop) available (operating status o10.20),  
"switch-on inhibit" is active  
1 Safety shutdown (E stop) is not available.

Function: Refer to Section 10., Fig. 1 (status description, binary outputs).

### 10.4.11 Checkback signal of the binary input function BEF55 (operating enable with the checkback signal "line contactor switched-in" (low active))

(also refer to Section 10.3.55)

The function can be parameterized at the select outputs "Select output binary 1" (terminal 46) to "Select output binary 4" (terminal 52) with setting 11 of the particular select parameter.

Signal level: 0 The binary input signal BEF55 is high ("line contactor switched-in").  
1 binary input signal BEF55 is low ("line contactor is switched-out").

### 10.4.12 Rump-function generator active

The function can be parameterized at the select outputs "Select output binary 1" (terminal 46) to "Select output binary 4" (terminal 52) with setting 12 of the particular select parameter.

Signal level: 0 The ramp-function generator output is the same as the ramp-function generator input  
1 The ramp-function generator output is not the same as the ramp-generator input.

### 10.4.13 Counter-clockwise direction of rotation

The function can be parameterized at the select outputs "Select output binary 1" (terminal 46) to "Select output binary 4" (terminal 52) with setting 13 of the particular select parameter.

Signal level: 0 Clockwise direction of rotation, speed actual value K167 is more positive than the negative hysteresis (- P396)  
1 Counter-clockwise direction of rotation, speed actual value K167 is more negative than the hysteresis (+ P396).

Effect of the hysteresis:

The signal level changes from low to high, if the speed actual value K167 is more negative than the negative hysteresis (-- P396).

The signal level changes from high to low if the speed actual value K167 is more positive than

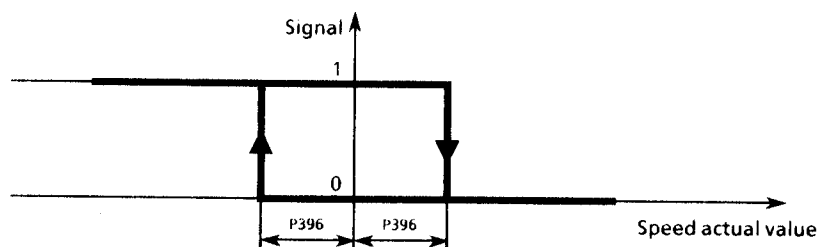

the hysteresis (+ P396).

#### 10.4.14 Switch-on command for the holding- or operating brake (low active)

Function has been partially changed from SW2.00 onwards.

This binary output function (BAF14) can be parameterized at the "Select output binary 1" (terminal 46) to "Select output binary 4" (terminal 52) with setting 14 of the particular select parameter.

Signal level: 0 Command "close brake"  
1 Command "open brake"

The following parameters influence the function of the brake control signal:

P080 = 1 The brake is a holding brake ("close brake" command is only issued when  $n < n_{min}$  (P370, P371))

P080 = 2 The brake is an operating brake ("close brake" command is also output when the motor is running).

P087 Brake opening time (a positive value prevents the motor rotating against a brake which is in the process of opening, a negative value means that the motor continues to rotate against a still closed brake, in order to prevent a short torque-free condition).

P088 Brake closing time (this means that the motor still generates a torque while the brake is closing).

The following diagrams illustrate the brake control sequence for signal level changes at the "switch-on/shutdown" inputs (e.g. terminal 37) and "operating enable" (terminal 38).

As far as the brake control is concerned, the input commands "inching", "crawl" or "fast stop" act like "switch-on/shut down", the input commands "disconnect voltage" or "E stop" the same as when the "operating enable" command is withdrawn.

The "close brake" command is output during the optimization run for the pre-control and current controller (P051 = 25).



### Operating brake (P080 = 2), brake opening time (P087) positive

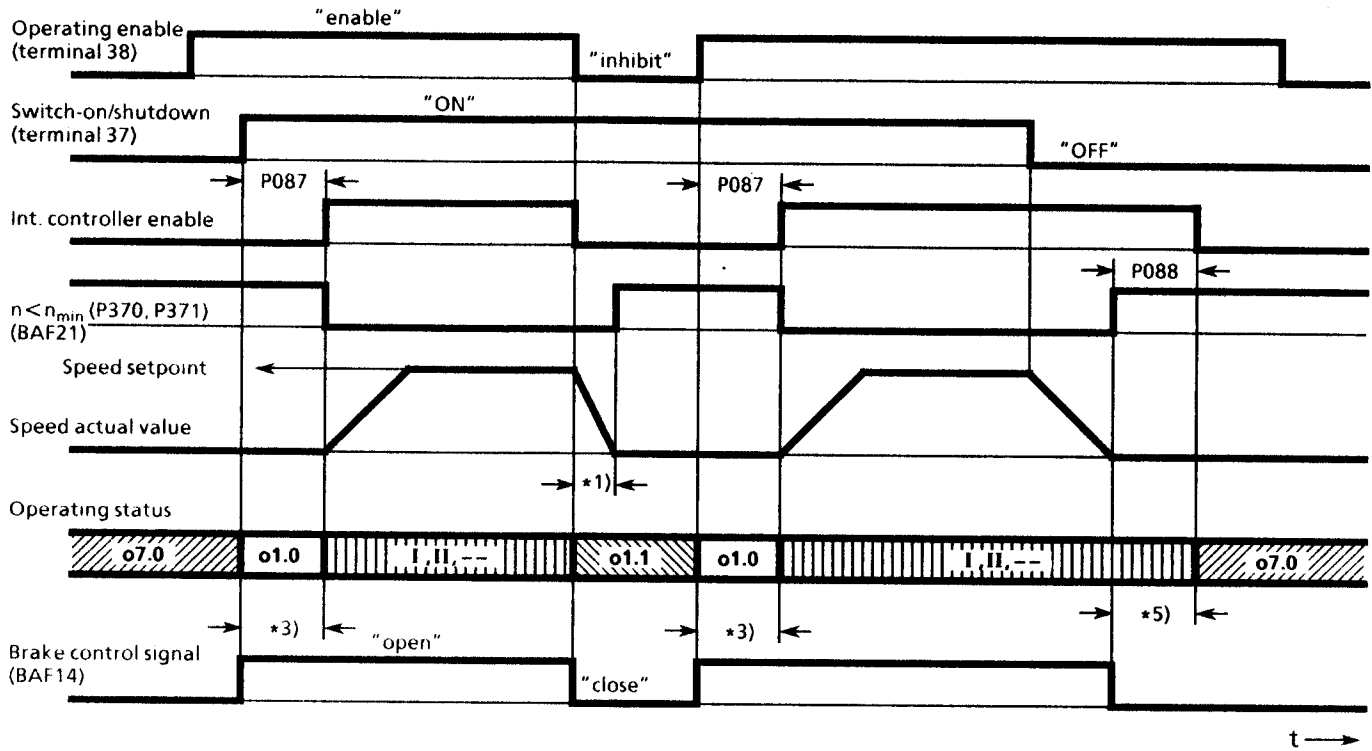

### Holding brake (P080 = 1), brake opening time (P087) positive

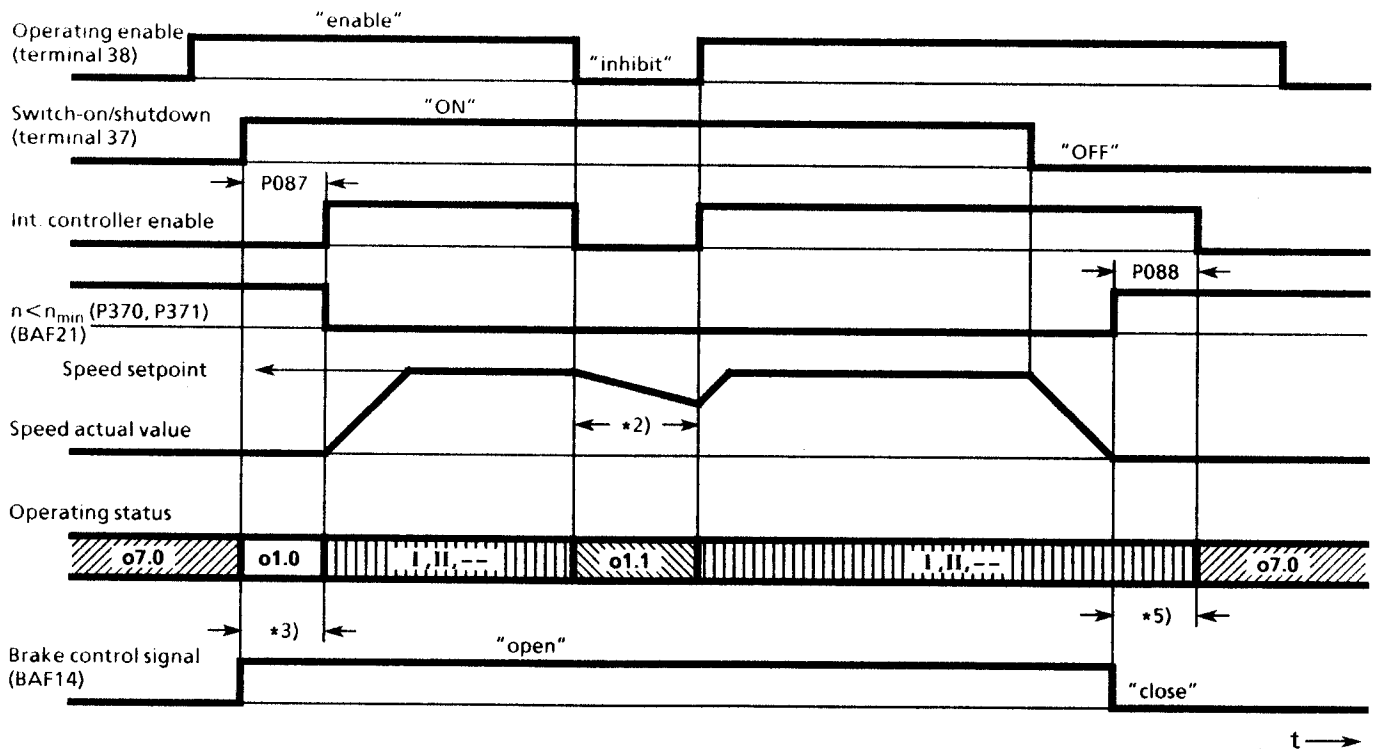

- \*1) The drive is mechanically braked using the operating brake
- \*2) The drive coasts down, "close holding brake" is only issued when  $n < n_{min}$
- \*3) Time for the brake to open before the motor develops a torque (P087 positive)
- \*5) Time for the brake to close while the motor is still establishing a torque (P088)

**Operating brake (P080 = 2), brake opening time (P087) negative**

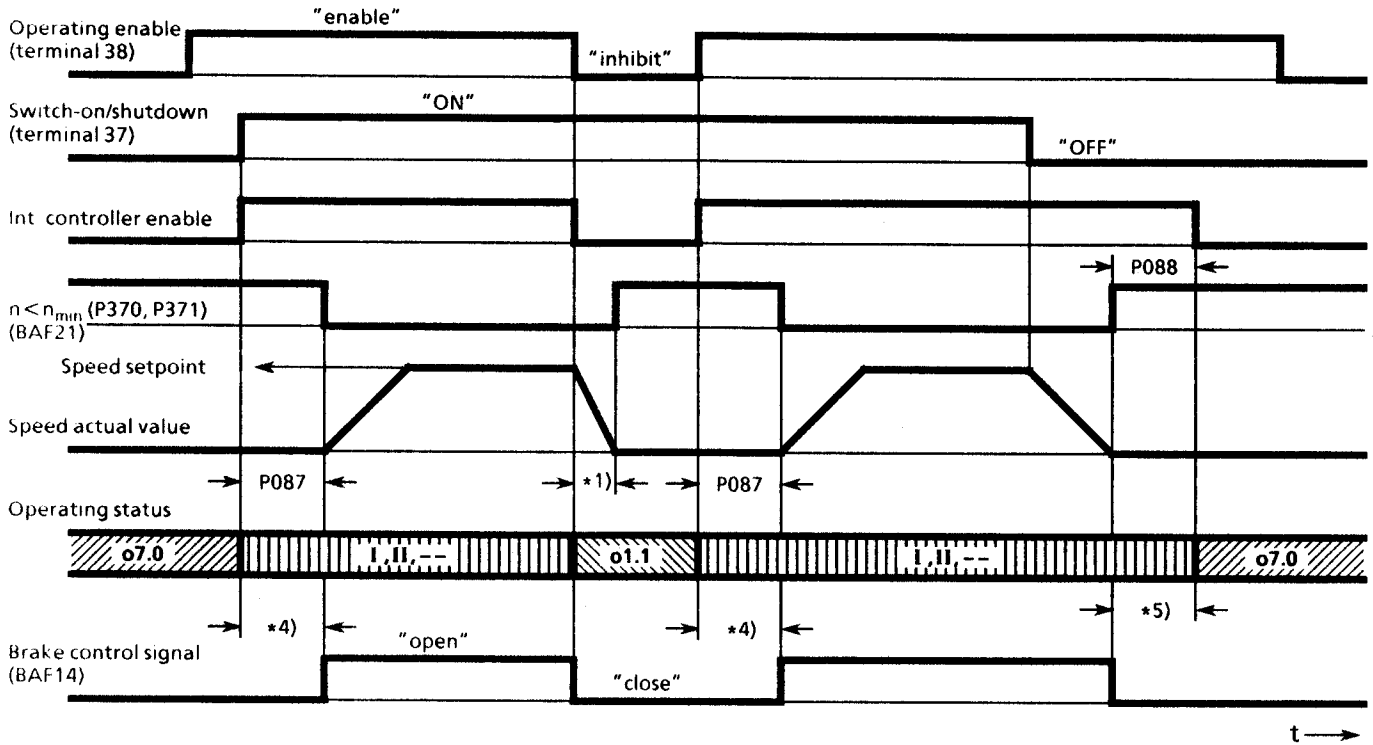

**Holding brake (P080 = 1), brake opening time (P087) negative**

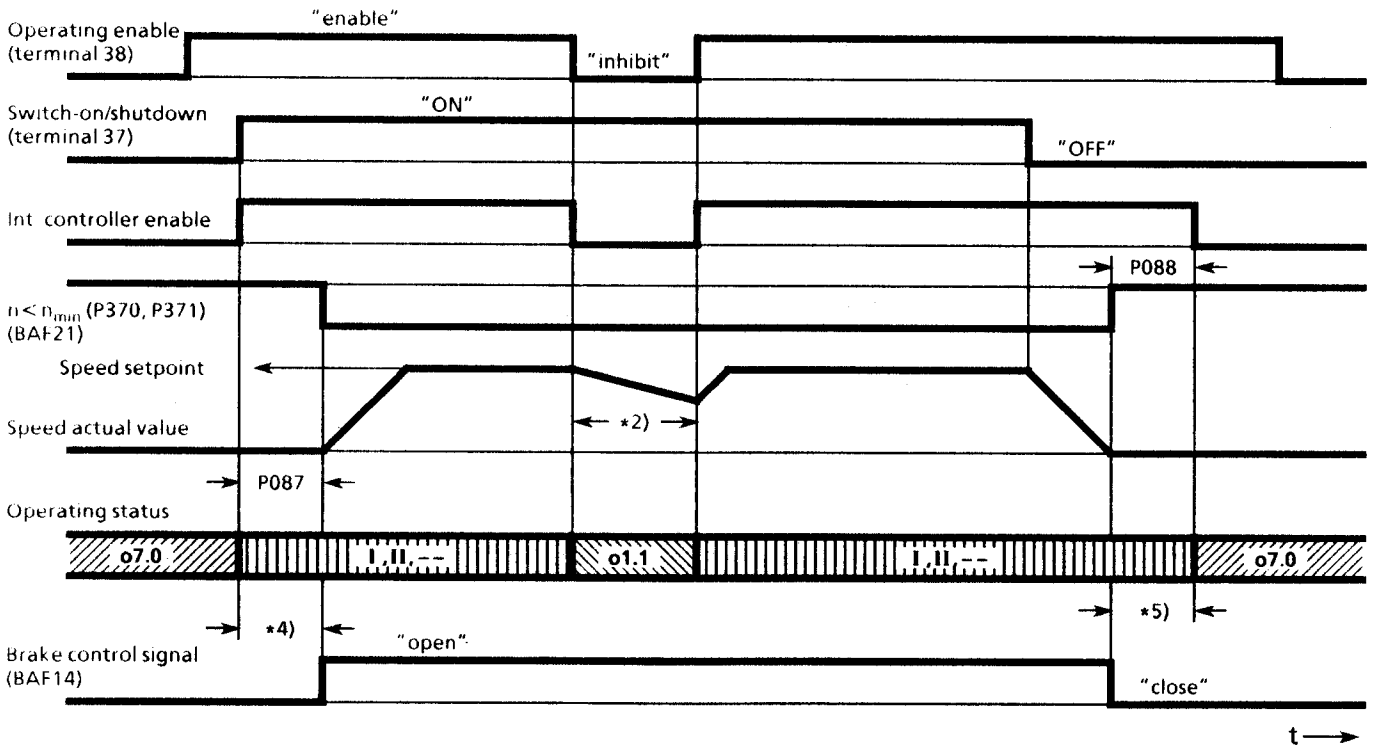

- \*1) The drive is mechanically braked using the operating brake
- \*2) The drive coasts down, "close holding brake" is only issued when  $n < n_{min}$
- \*4) The motor still rotates against the closed brake (P087 negative)
- \*5) Time for the brake to close while the motor is still establishing a torque (P088)

### 10.4.15 $I_A > I_X$ (Current limit value monitor)

The functions can be parameterized at the select outputs "select output, binary 1" (terminal 46) to "select output, binary 4" (terminal 52) with setting 15 of the particular select parameter.

Threshold: P391 (as a % of the rated DC armature converter current according to P072)

Hysteresis: P392 (as a % of the rated DC armature converter current according to P072)

Signal level: 0 The armature current actual value (K116) is less than the sum of the threshold set at parameter P391, and the hysteresis, set at parameter P392.

1 The armature current actual value (K116) is greater than the threshold set at parameter P391.

Effect of the hysteresis:

The signal level changes from L to H for  $I_A > I_X$  (P391) + hysteresis (P392).

The signal level changes from H to L at  $I_A < I_X$  (P391).

### 10.4.16 to 10.4.21 Speed limit value monitor

The functions can be parameterized at the select outputs "select output, binary 1" (terminal

| Function       | Setting | Threshold           |      | Hysteresis |
|----------------|---------|---------------------|------|------------|
| $n < n_{base}$ | 16      | $n_{base} = n_{x1}$ | P373 | P374       |
| $n < n_{x2}$   | 17      | $n_{x2}$            | P376 | P377       |
| $n < n_{x3}$   | 18      | $n_{x3}$            | P379 | P380       |
| $n < n_{x4}$   | 19      | $n_{x4}$            | P382 | P383       |
| $n < n_{x5}$   | 20      | $n_{x5}$            | P385 | P386       |
| $n < n_{min}$  | 21      | $n_{min}$           | P370 | P371       |

46) to "select output, binary 4" (terminal 52) with setting 16 to 21 of the particular select parameter.

Signal level: 0 The speed actual value (K166) is greater than the particular threshold.

1 The speed actual value (K166) is less than the sum of the particular threshold and hysteresis.

Effect of the hysteresis:

The signal level changes from H to L when  $n > \text{threshold} + \text{hysteresis}$

The signal level changes from L to H when  $n < \text{threshold}$ .

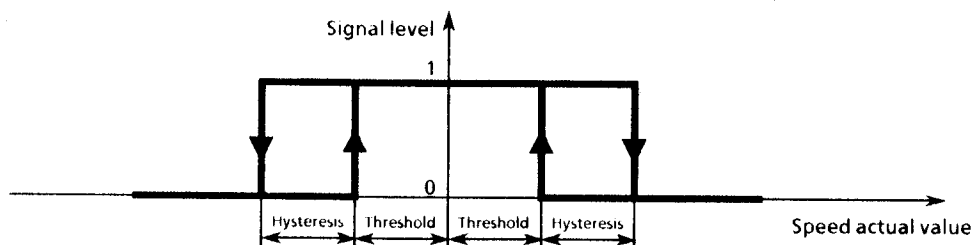

Note:

The status bit " $n < n_{base}$ " from status word ZSW1.9 coincides with the logical signal level of this binary output function; however, the status bit " $n < n_{base}$ " from status word ZSW.10 has the inverted signal level (refer to Sections 10.6.1 and 10.6.2).

Note:

The " $n < n_{min}$ " signal also influences the control sequence at "shutdown" (refer to Section 10.3.90), "fast stop" (refer to Section 10.3.4) and when withdrawing the command "inching" or "crawl" (also refer to Sections 10.3.13 to 10.3.16) as well as the brake control (refer to Section 10.4.14).

**10.4.22  $n_{set}$  reached signal (speed controller monitoring)**

The function can be parameterized at the select outputs "select output, binary 1" (terminal 46) to "select output binary 4" (terminal 52) with setting 22 of the particular select parameter.

Threshold: P362 (% of the maximum speed)

Time : P363 (s)

- Signal level:
- 0 The deviation between the setpoint and the actual value at the speed controller input is longer than the time set at parameter P363, and greater than the threshold (P362).
  - 1 The deviation at the speed controller input is shorter than the time set at parameter P363, and/or less than the threshold (P362).

**10.4.23  $n < n_{excess}$** 

The function can be parameterized at the select outputs "select output, binary 1" (terminal 46) to "select output binary 4" (terminal 52) with setting 23 of the particular select parameter.

Function, also refer to fault F038.

This message is also displayed, even when the fault message is suppressed.

- Signal level:
- 0 The speed actual value (K166) is greater than the threshold set at parameter P354. F038 is initiated (if not suppressed).
  - 1 The speed actual value (K166) is less than the threshold set at parameter P354 (+ 0.5% hysteresis).

Note:

This message has a hysteresis of 0.5% of the maximum speed. The transition from H to L is realized at the speed actual value (K166) >  $n_{excess}$  (P354) + 0.5%.

**10.4.24 Alarm (low active)**

The function can be parameterized at the select outputs "select output, binary 1" (terminal 46) to "select output, binary 4" (terminal 52) with setting 24 of the particular select parameter.

Also refer to Section 8.3 "Alarms" for the function.

- Signal level:
- 0 An alarm is present (the alarms are indicated at parameters P049 and P050, refer to Section 8.3.1).
  - 1 No alarm is present.

Note:

The "alarm" status bit of the status word (ZSW.7) has the inverse logical signal level to this binary output function (refer to Section 10.6.1).

**10.4.25 Alarm "motor overload" (W01, W05, W06) (low active)**

The function can be parameterized at the select outputs "select output, binary 1" (terminal 46) to "select output, binary 4" (terminal 52) with setting 25 of the particular select parameter.

Also refer to Section 8.3 "Alarms" for the function.

- Signal level:
- 0 Alarm W01 (motor overtemperature) or W05 (motor temperature, binary) or W06 (motor temperature, analog) are present (alarms are displayed at parameters P049 and P050, refer to Section 8.3.1).
  - 1 No alarm present.

#### 10.4.26 Alarm "converter overload" (low active)

The function can be parameterized at the select outputs "select output, binary 1" (terminal 46) to "select output, binary 4" (terminal 52) with setting 26 of the particular select parameter.

For the function, also refer to Section 8.3 "Alarms" W10 and Section 8.2 "Fault messages" F039 as well as Section 10.9.

Signal level: 0 Alarm W10 ( $I^2t$  value of the power section too high)  
1 No alarm present.

#### 10.4.27 Converter cooling faulted (low active)

The function can be parameterized at the select outputs "select output, binary 1" (terminal 46) to "select output, binary 4" (terminal 52) with setting 27 of the particular select parameter.

Function, also refer to Section 8.2 "Fault messages" F110.

The message is also displayed when fault message F110 is suppressed.

Signal level: 0 The conditions for fault message F110 are fulfilled.  
1 Converter cooling is not faulted.

#### 10.4.28 $I_{\text{field}} < I_{\text{fmin}}$ (low active)

The function can be parameterized at the select outputs "select output, binary 1" (terminal 46) to "select output, binary 4" (terminal 52) with setting 28 of the particular select parameter.

Threshold: P394 (as a % of the rated converter DC field current according to P073)

Hysteresis: P395 (as a % of the rated converter DC field current according to P073)

Signal level: 0 The field current controller actual value (K265) is less than the sum of the threshold, set at parameter P394, and the hysteresis, set at parameter P395.  
1 The field current controller actual value (K265) is greater than the threshold set at parameter P394.

Effect of the hysteresis:

The signal level changes from L to H for  $I_{\text{field}} > I_{\text{fmin}} (\text{P394}) + \text{hysteresis} (\text{P395})$ .

The signal level changes from H to L for  $I_{\text{field}} < I_{\text{fmin}} (\text{P394})$ .

#### 10.4.29 $I_{\text{aset}} = I_{\text{limit}}$ (actual current limit reached)

The function can be parameterized at the select outputs "select output, binary 1" (terminal 46) to "select output, binary 4" (terminal 52) with setting 29 of the particular select parameter.

Signal level: 0 The armature current setpoint did not reach the actual armature current limit (K131, K132).  
1 The armature current setpoint reached the actual positive (K131) or negative (K132) armature current limit.

**10.4.30 Switch-in field contactor 1****from SW2.00**

The function can be parameterized at the select outputs "select output, binary 1" (terminal 46) to "select output, binary 4" (terminal 52) with setting 30 of the particular select parameter.

This signal, together with the "close field contactor 2" signal is used to control a reversing contactor for changing over the field for 1-quadrant converters with field reversal.

Signal level: 0 Contactor not energized  
1 Contactor energized to switch-through the positive field direction.

Application:

Direction of rotation reversal and braking by reversing the field voltage (field reversal) for higher-rating single-quadrant 6RA24 converters.

Two contactors in the field circuit (1, 2) reverse the field voltage (field reversal). The contactors are controlled via the binary output functions "field contactor 1 in" (BAF30) and "field contactor 2 in" (BAF31).

An appropriate internal sequence to energize the contactors is initiated (refer to Sections 10.3.57 and 10.3.58) using the binary input functions "direction of rotation reversal using field reversal" (BEF57) and "braking using field reversal" (BEF58).

Protective circuitry is necessary in the field circuit.

**10.4.31 Close field contactor 2****from SW2.00**

The function can be parameterized at the select outputs "select output, binary 1" (terminal 46) to "select output, binary 4" (terminal 52) with setting 31 of the particular select parameter.

This signal, together with the "close field contactor 1" signal is used to energize a reversing contactor to reverse the field for single-quadrant converters with field reversal (refer to Section 10.4.30).

Signal level: 0 Contactor not energized  
1 Contactor energized to switch-through the negative field direction.

**10.4.32 Torque direction signal****changed from SW2.00**

The function can be parameterized at select outputs "select output, binary 1" (terminal 46) to "select output, binary 4" (terminal 52) with setting 32 of the particular select parameter.

Signal level: 0 Torque direction II or no torque direction (--) is selected, or the drive is ready for torque direction II to be selected.  
1 Torque direction I or no torque direction (--) is selected, or the drive is ready for torque direction I to be selected.

Refer to Section 10.3.60 for an application of this binary output function.

### 10.4.33 Power section warm

The function can be parameterized at the select outputs "select output, binary 1" (terminal 46) to "select output, binary 4" (terminal 52) with setting 33 of the particular select parameter.

Signal level: 0 The calculated equivalent barrier junction temperature rise <5% of its maximum permissible value - the power section is considered "cold".  
1 The calculated equivalent barrier junction temperature rise >5% of its maximum permissible value - the power section is considered "warm".

### 10.4.34 Output of the freely-configurable limit value monitor 1 from SW2.00

(refer to Section 10.1, Sheet 9)

Parameter P692 controls the function (refer to Section 9.2).

### 10.4.35 Output of the freely-configurable limit value monitor 2 from SW2.00

(refer to Section 10.1, Sheet 9)

Parameter P694 controls the function (refer to Section 9.2).

## 10.5 Control words

### 10.5.1 Control word STW (K315)

(also refer to "binary input functions" in Section 10.3)

The significance of the control word is global for Siemens and is defined, in the Instruction Manual "Data transfer between SIMOVERT-P- or SIMOREG K converters and expansion boards" Order No.: 6DD1902-0GE0. The following are the functions used for 6RA24 converters:

| Bit |   |       | Function (a detailed description of the functions are provided in the description of the binary input functions) |
|-----|---|-------|--|
| 0   | 0 | OFF 1 | Shutdown   |
|     | 1 | EIN   | Switch-on  |
| 1   | 0 | OFF 2 | Voltage disconnect   |
|     | 1 |       | No voltage disconnect  |
| 2   | 0 | OFF 3 | Fast stop  |
|     | 1 |       | No fast stop   |
| 3   | 0 |       | No operating enable  |
|     | 1 |       | Operating enable   |
| 4   | 0 |       | No ramp-function generator enable  |
|     | 1 |       | Ramp-function generator enable   |
| 5   |   |       | <b>Caution!</b><br>Bit 5 has a different significance depending on the interface and protocol used!              |
|     | 0 |       | <b>For the G-SST0 and G-SST1 basic converter interface with USS protocol:</b><br>Ramp-function generator STOP    |
|     | 1 |       | No ramp-function generator STOP  |
|     | 0 |       | <b>For control word with dual port Ram:</b><br>No ramp-function generator STOP                                   |
|     | 1 |       | Ramp-function generator STOP   |
| 6   | 0 |       | No setpoint enable   |
|     | 1 |       | Setpoint enable  |
| 7   | 0 |       | No significance  |
|     | 1 |       | Fault acknowledgement  |
| 8   |   |       | Not used for 6RA24 converters  |
| 9   |   |       | Not used for 6RA24 converters  |
| 10  | 0 |       | No control from the PLC, "old" process data remain in the dual port RAM  |
|     | 1 |       | Control via the interface, process data are valid  |
| 11  |   |       | Not used for 6RA24 converters  |
| 12  |   |       | Not used for 6RA24 converters  |
| 13  |   |       | Not used for 6RA24 converters  |
| 14  |   |       | Not used for 6RA24 converters  |
| 15  |   |       | Not used for 6RA24 converters  |



Parameter **P640** is used to select the connector which supplies control word STW with data (e.g. P640 = 20 means that the control word comes from the first PZD value of the G-SST0 basic serial converter interface).

The status of the STW bit is available at connector K315 and is indicated at parameter P010.01 (also refer to P010 in Section 9.2 and Section 10.1, Sheet 6).

The individual control word bits are logically combined with the terminal functions and the STWF (refer to the table in Section 10.5.2).

The logical status of the binary input terminals is available at connector K335 and is indicated at parameter P010.00 (also refer to P010 in Sections 9.2 and 10.1, Sheet 6).

The status of the STW bits after being logically combined with the binary terminal input functions is available at connector K317, and is indicated at parameter P010.03 (also refer to P010 in Sections 9.2 and 10.1, Sheet 6).

## 10.5.2 Converter-specific, freely-definable control word STWF (K316)

(also refer to "binary input functions" in Section 10.3)

The control word assignment can be parameterized using parameter **P642**. Parameter P642 is an indexed parameter, whereby the function of bit 0, is defined in the converter-specific control word via index 0, the function of bit 1 with index 1 up to index 15 → bit 15. The number of the binary input function should be set as parameter value (refer to the following table).

Parameter **P641** is used to define which connector is used to supply the STWF with data (e.g. P641 = 52 means that STW comes from the first received data at PZD-SOW channel 1 of the dual port RAM).

The status of the STWF bits is available at connector K316 and is indicated at parameter P010.02 (also refer to P010 in Sections 9.2 and 10.1, Sheet 6).

The individual bits of control word STW are logically combined with the terminal functions and the freely-definable control word STWF (refer to the subsequent table).

The logical status of the binary input terminals is available at connector K335 and is indicated at parameter P010.00 (also refer to P010 in Sections 9.2 and 10.1, Sheet 6).

The status of the STWF bits after being logically combined with the binary terminal input functions is available at connector K318 and is indicated at parameter P010.04 (also refer to P010 in Sections 9.2 and 10.1, Sheet 6).

All of the possible binary input functions are listed in the following table. The grey fields indicate which function is controlled from which input (binary input terminal, STW, STWF). Further, it is specified, as to whether the input signals are logically "OR'd" or "AND'ed" if the associated binary input function is energized from several input sources.

A precise description of each of the individual functions is provided in Section 10.3.1, whereby the section number coincides with the number of the particular binary input function so that it can be easily found.

Although the functions are described for using the binary select terminals as control inputs, they are also valid in the same sense when controlled via the STWF bits.

| BEF No. | Function  | can be controlled from → | Term. 1) | STW   | STWF | Logic operation |
|---------|---|--------------------------|----------|-------|------|-----------------|
| 0       | No function   |                          |          |       |      |                 |
| 1       | No function   |                          |          |       |      |                 |
| 2       | Shutdown pushbutton (low active)  | from SW2.00              |          |       |      | AND             |
| 3       | Voltage disconnect (OFF2) (low active)                                      | from SW2.00              |          | Bit 1 |      | AND             |
| 4       | Fast stop (OFF3) (low active)   |                          |          | Bit 2 |      | AND             |
| 5       | Fault acknowledgement   |                          |          | Bit 7 |      | OR              |
| 6       | Enable technology controller  | from SW1.10              |          |       |      | AND             |
| 7       | Enable speed controller   |                          |          |       |      | AND             |
| 8       | Enable EMF controller   |                          |          |       |      | AND             |
| 9       | Ramp-function generator enable  |                          |          | Bit 4 |      | AND             |
| 10      | Ramp-function generator stop  |                          |          | Bit 5 |      | OR              |
| 11      | Setpoint enable   |                          |          | Bit 6 |      | AND             |
| 12      | Wobulation enable (oscillation)   | from SW2.00              |          |       |      | OR              |
| 13      | Inching   |                          |          |       |      | OR              |
| 14      | Inching and bypass ramp-function generator                                  |                          |          |       |      | OR              |
| 15      | Crawl   |                          |          |       |      | OR              |
| 16      | Crawl and bypass ramp-function generator                                    |                          |          |       |      | OR              |
| 17      | Fixed setpoint  |                          |          |       |      | OR              |
| 18      | Fixed setpoint and bypass ramp-function generator                           |                          |          |       |      | OR              |
| 19      | Suppl. setpoint before the techn. controller                                | from SW1.10              |          |       |      | OR              |
| 20      | Suppl. setpoint before the ramp-function generator                          |                          |          |       |      | OR              |
| 21      | Suppl. setpoint before the speed controller                                 |                          |          |       |      | OR              |
| 22      | Suppl. setpoint before torque limiting                                      |                          |          |       |      | OR              |
| 23      | Suppl. setpoint before the current controller                               |                          |          |       |      | OR              |
| 24      | Setpoint reduction (P315, P316, P319, P320)                                 |                          |          |       |      | OR              |
| 25      | Mot. pot., manual/auto. (switch)  | from SW1.10              |          |       |      | OR              |
| 26      | Mot. pot., raise setpoint   | from SW1.10              |          |       |      | OR              |
| 27      | Mot. pot., lower setpoint   | from SW1.10              |          |       |      | OR              |
| 28      | Mot. pot., CW/CCW (switch)  | from SW1.10              |          |       |      | OR              |
| 29      | Mot. pot., clockwise (button)   | from SW1.10              |          |       |      |                 |
| 30      | Mot. pot., counter-clockwise (button)                                       | from SW1.10              |          |       |      |                 |
| 31      | Ramp-function generator setting 2 (P307 to P310)                            |                          |          |       |      | OR              |
| 32      | Ramp-function generator setting 3 (P311 to P314)                            |                          |          |       |      | OR              |
| 33      | Use parameter set 2   | from SW2.00              |          |       |      | OR              |
| 34      | Use parameter set 3   | from SW2.00              |          |       |      | OR              |
| 35      | Use parameter set 4   | from SW2.00              |          |       |      | OR              |
| 36      | Enable technology controller droop  | from SW1.10              |          |       |      | AND             |
| 37      | Enable speed controller droop   | from SW1.10              |          |       |      | AND             |
| 38      | Enable signal for PI/P changeover, speed controller                         |                          |          |       |      | AND             |
| 39      | Enable signal for dv/dt injection   | from SW1.10              |          |       |      | AND             |
| 40      | Speed controller, actual value polarity reversal                            |                          |          |       |      | OR              |
| 41      | Changeover, master/slave drive  |                          |          |       |      | OR              |
| 42      | Changeover, torque limiting   |                          |          |       |      | OR              |
| 43      | Switch-in the analog input "main setpoint" (terminals 4 and 5)              |                          |          |       |      | AND             |
| 44      | Switch-in the analog input "main actual value" (terminals 101, 102 and 103) |                          |          |       |      | AND             |

1) Terminals 39, 40, 41, 42, 43 or 36, if a terminal number is not specified here.

| BEF No. | Function  | can be controlled from → | Term. 1) | STW    | STWF | Logic operation |
|---------|---|--------------------------|----------|--------|------|-----------------|
| 45      | Switch-in analog input "select input, analog 1" (terminals 6 und 7)                             |                          |          |        |      | AND             |
| 46      | Switch-in analog input "select input, analog 2" (terminal 8)                                    |                          |          |        |      | AND             |
| 47      | Switch-in analog input "select input, analog 3" (terminal 10)                                   |                          |          |        |      | AND             |
| 48      | Polarity, analog input, "main setpoint" (terminals 4 and 5)                                     |                          |          |        |      | OR              |
| 49      | Polarity, analog input, "main actual value" (terminals 101, 102 and 103)                        |                          |          |        |      | OR              |
| 50      | Polarity, analog input "select input, analog 1" (terminals 6 and 7)                             |                          |          |        |      | OR              |
| 51      | Polarity, analog input "select input, analog 2" (terminal 8)                                    |                          |          |        |      | OR              |
| 52      | Polarity, analog input "select input, analog 3" (terminal 10)                                   |                          |          |        |      | OR              |
| 53      | External fault (low active), delay time until the fault message responds, can be set using P767 |                          |          |        |      | AND             |
| 54      | External alarm (low active)   |                          |          |        |      | AND             |
| 55      | Operating enable with the checkback signal "line contactor closed"                              |                          |          |        |      | AND             |
| 56      | Standstill excitation   |                          |          |        |      | OR              |
| 57      | Direction of rot. reversal using field rev.   | from SW2.00              |          |        |      | OR              |
| 58      | Braking using field reversal  | from SW2.00              |          |        |      | OR              |
| 59      | $I_{field\ external} < I_{f\ min}$ (low active)   |                          |          |        |      | AND             |
| 60      | Enabling a torque direction for torque direction change with a parallel drive                   | from SW2.00              |          |        |      |                 |
| 61      | Set binary select output 1, if P771 = 2   | from SW1.10              |          |        |      | OR              |
| 62      | Set binary select output 2, if P772 = 2   | from SW1.10              |          |        |      | OR              |
| 63      | Set binary select output 3, if P773 = 2   | from SW1.10              |          |        |      | OR              |
| 64      | Set binary select output 4, if P774 = 2   | from SW1.10              |          |        |      | OR              |
| 65      | Change. command for free change. switch 1   | from SW2.00              |          |        |      | OR              |
| 66      | Change. command for free change. switch 2   | from SW2.00              |          |        |      | OR              |
| 67      | Change. command for free change. switch 3   | from SW2.00              |          |        |      | OR              |
| 68      | Set motorized potentiometer   | from SW2.00              |          |        |      | OR              |
|         | Switch-on/shutdown (ON/OFF)   |                          | 37       | Bit 0  |      | AND             |
|         | Operating enable  |                          | 38       | Bit 3  |      | AND             |
|         | Control from the PLC  |                          |          | Bit 10 |      |                 |

1) Terminals 39, 40, 41, 42, 43 or 36, if a terminal number is not specified here.

**Assignment of the fixed setpoints (P409 to P419) to the particular binary input functions BEF13 to BEF23 when requesting the particular function via a bit of the converter-specific freely-definable control word STWF**

| BEF No. | Function   | Parameter |
|---------|--|-----------|
| 13      | Inching <sup>1)</sup>  | P409      |
| 14      | Inching and bypass ramp-function generator <sup>1)</sup>                   | P410      |
| 15      | Crawl <sup>2)</sup>  | P411      |
| 16      | Crawl and bypass ramp-function generator <sup>2)</sup>                     | P412      |
| 17      | Fixed setpoint <sup>2)</sup>   | P413      |
| 18      | Fixed setpoint and bypass ramp-function generator <sup>2)</sup>            | P414      |
| 19      | Suppl. setpoint before the technology controller <sup>2)</sup> from SW1.10 | P415      |
| 20      | Suppl. setpoint before the ramp-function generator <sup>2)</sup>           | P416      |
| 21      | Suppl. setpoint before the speed controller <sup>2)</sup>                  | P417      |
| 22      | Suppl. setpoint before torque limiting <sup>2)</sup>                       | P418      |
| 23      | Suppl. setpoint before the current controller <sup>2)</sup>                | P419      |

- 1) If the function is requested from two sources (e.g. terminal and STWF), then 0 is entered as setpoint.
- 2) If the function is requested from two sources (e.g. terminal and STWF), then the setpoints, set at the parameters, are added.

## 10.6 Status words

### 10.6.1 Status word ZSW (K325)

Status word ZSW is available as connector K325 and is indicated at parameter P011.01 (also refer to Section 10.1, Sheet 4).

For those functions which are also available as binary output functions (refer to Section 10.4), the appropriate BAF number is specified. However, for several functions, the following specified logical signal levels of the ZSW bits, do not correspond to logical signal levels of the appropriate binary output functions.

The assignment of the status word is, for Siemens, defined globally in the Instruction Manual "Data transfer between SIMOVERT P or SIMOREG K converters and expansion boards" Order No.: 6DD1902-0GE0. The functions used for the 6RA24 converters are subsequently listed:

| Bit |   | Function (a detailed description of the functions is provided in the description of the binary output functions, Section 10.4)  | BAF Nr. |
|-----|---|---|---------|
| 0   | 0 | Not "ready to switch-on"  | 4       |
|     | 1 | "Ready to switch-on" (operating status o7)  |         |
| 1   | 0 | Not "ready"   | 5       |
|     | 1 | "Ready" (operating status o1)   |         |
| 2   | 0 | "Run" inhibited   | 6       |
|     | 1 | "Run" enabled (operating status I, II or --)  |         |
| 3   | 0 | "Fault free"  | 3 1)    |
|     | 1 | "Fault"   |         |
| 4   | 0 | Voltage disconnect (OFF 2) present (low active)   |         |
|     | 1 | Voltage disconnect (OFF 2) not present  |         |
| 5   | 0 | Fast stop (OFF 3) present (low active)  |         |
|     | 1 | Fast stop (OFF 3) not present   |         |
| 6   | 0 | No "switch-on inhibit"  | 9 2)    |
|     | 1 | "Switch-on inhibit" (operating statuses $\geq$ o8))   |         |
| 7   | 0 | No "alarm"  | 24 3)   |
|     | 1 | "Alarm" (displays the alarms at P049 and P050)  |         |
| 8   | 0 | Setpoint/actual value monitoring is not in the tolerance range. The deviation at the speed controller input is present longer than the time set at parameter P363 and greater than the threshold set at parameter P362. | 22      |
|     | 1 | Setpoint/actual value monitoring in the tolerance range. The deviation at the speed controller input is present for less than the time set at parameter P363, and less than the threshold set at parameter P362.        |         |
| 9   | 0 | Local operation; Control only possible at the converter.  |         |
|     | 1 | Control requested; the automation system is requested to accept control (checkback signal via bit 10 in the STW)  |         |
| 10  | 0 | $n < n_{base} (P373) + \text{hysteresis} (P374)$  | 16 4)   |
|     | 1 | $n > n_{base} (P373)$   |         |
| 11  |   | Not used for 6RA24 converters   |         |
| 12  |   | Not used for 6RA24 converters   |         |
| 13  |   | Not used for 6RA24 converters   |         |
| 14  |   | Not used for 6RA24 converters   |         |
| 15  |   | Not used for 6RA24 converters   |         |

- 1) Signal level inverted with respect to BAF3
- 2) Signal level inverted with respect to BAF9 ("line contactor energization OFF" (low active))
- 3) Signal level inverted with respect to BAF24
- 4) Signal level inverted with respect to BAF16 and ZSW1.9

Status description of several bits of the STW control word

Status word ZSW

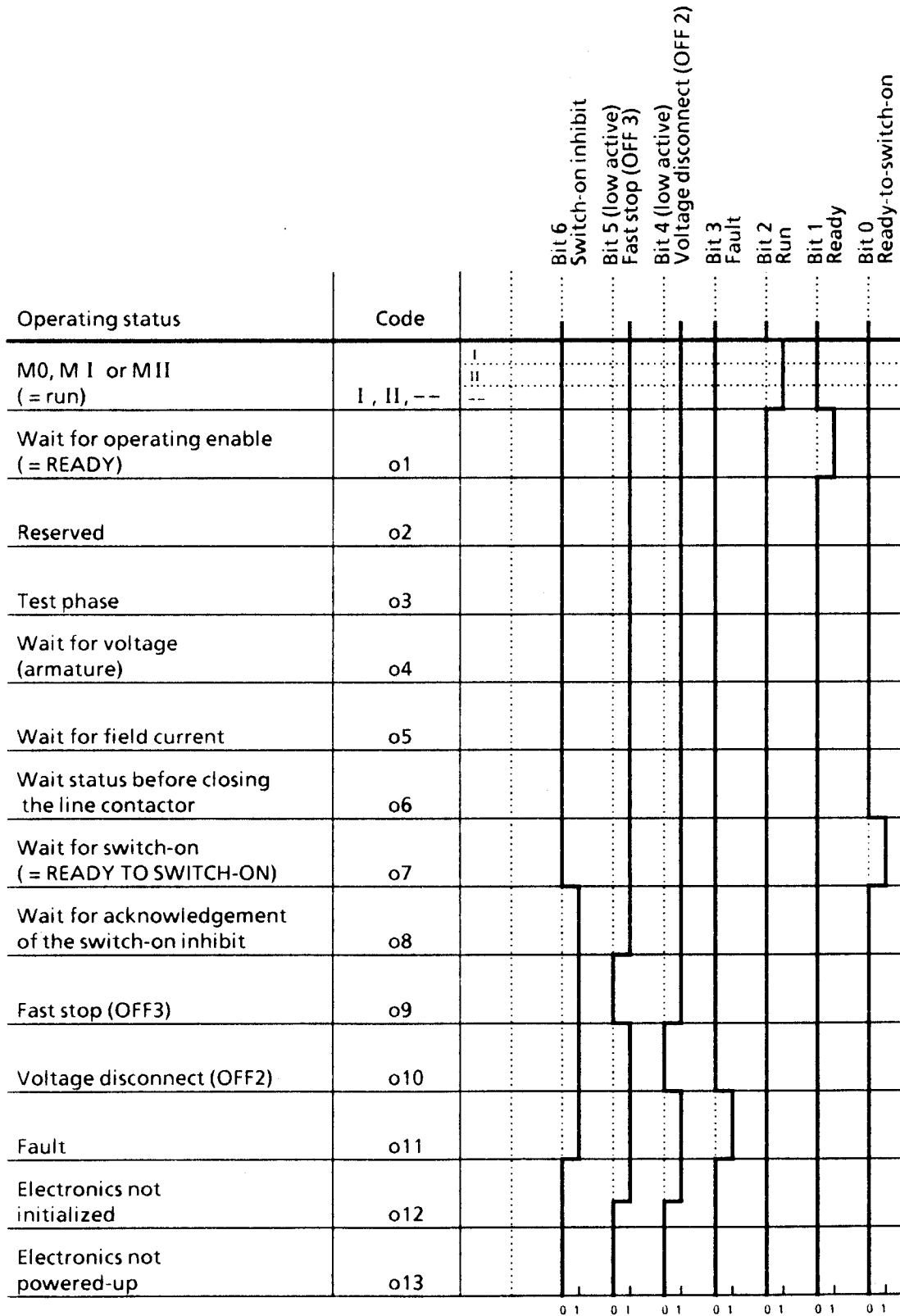

## 10.6.2 Converter-specific status word ZSW1 (K326)

The converter-specific status word ZSW1 is available as connector K326, and is indicated at parameter P011.02 (also refer to Section 10.1, Sheet 4).

The functions of the individual bits are also available as binary output functions (refer to Section 10.4); the appropriate BAF number is specified.

The status word assignment is converter-specific.

| Bit |   | Function (refer to the description of the binary output functions in Section 10.4 for a detailed description of the functions)               | BAF No. |
|-----|---|--|---------|
| 0   | 0 | Auxiliaries OFF  | 7       |
|     | 1 | Auxiliaries ON   |         |
| 1   | 0 | Supply voltage (armature and field) present<br>The drive is in an operating status $\geq o4$ .   | 8       |
|     | 1 | Supply voltage for armature and field present, the drive is in an operating status $< o4$ .  |         |
| 2   |   | Reserved for use later   |         |
| 3   | 0 | Line contactor OFF (= E stop) (low active)<br>Safety shutdown (E stop) present (operating status $o10.2$ ).<br>"Switch-on inhibit" is active | 10      |
|     | 1 | No safety shutdown present (E stop).   |         |
| 4   | 0 | Checkback signal of the binary input function BEF55 (low active)<br>The binary input signal BEF55 is high ("line contactor in").             | 11      |
|     | 1 | The binary input signal BEF55 is low ("line contactor out").   |         |
| 5   | 0 | Ramp-function generator active<br>The ramp-fct. gen. output is the same as the ramp-fct gen. input.  | 12      |
|     | 1 | The ramp-fct. gen. output is not the same as the ramp-fct. gen input.  |         |
| 6   | 0 | Clockwise $n > -P396$ (hysteresis)   | 13      |
|     | 1 | Counter-clockwise $n < +P396$ (hysteresis)   |         |
| 7   | 0 | Switch-on command for the holding- or operating brake (low active)<br>Close brake  | 14      |
|     | 1 | Open brake   |         |
| 8   | 0 | $I_A < I_X$ (P391) + hysteresis (P392)   | 15      |
|     | 1 | $I_A > I_X$ (P391)   |         |
| 9   | 0 | $n > n_{x1}$ ( $n_{base}$ ) (P373)   | 16      |
|     | 1 | $n < n_{x1}$ ( $n_{base}$ ) (P373) + hysteresis (P374)   |         |
| 10  | 0 | $n > n_{x2}$ (P376)  | 17      |
|     | 1 | $n < n_{x2}$ (P376) + hysteresis (P377)  |         |
| 11  | 0 | $n > n_{x3}$ (P379)  | 18      |
|     | 1 | $n < n_{x3}$ (P379) + hysteresis (P380)  |         |
| 12  | 0 | $n > n_{x4}$ (P382)  | 19      |
|     | 1 | $n < n_{x4}$ (P382) + hysteresis (P383)  |         |
| 13  | 0 | $n > n_{x5}$ (P385)  | 20      |
|     | 1 | $n < n_{x5}$ (P385) + hysteresis (P386)  |         |
| 14  | 0 | $n > n_{min}$ (P370)   | 21      |
|     | 1 | $n < n_{min}$ (P370) + hysteresis (P371)   |         |
| 15  | 0 | Not used for 6RA24 converters  |         |
|     | 1 |  |         |

### 10.6.3 Converter-specific status word ZSW2 (K327)

The converter-specific status word ZSW2 is available as connector K327, and is indicated at parameter P011.03 (also refer to Section 10.1, Sheet 4).

The functions of the individual bits are also available as binary output functions (refer to Section 10.4); the appropriate BAF number is specified.

The status word assignment is converter-specific.

| Bit |   | Function (a detailed description of the function is provided in the description of the binary output functions, Section 10.4)  | BAF No. |
|-----|---|--|---------|
| 0   | 0 | $n < n_{\text{excess}}$ (P354)<br>The speed actual value is greater than the threshold set at parameter P354. Fault F038 is initiated (if it is not suppressed).   | 23      |
|     | 1 | The speed actual value is less than the threshold set at parameter P354.   |         |
| 1   |   | Reserved for use later   |         |
| 2   | 0 | Alarm "motor overload" (low active)<br>Alarm W01 (motor overtemperature) or W05 (motor temperature, binary) or W06 (motor temperature, analog) present (alarm is indicated at parameters P049 and P050). | 25      |
|     | 1 | No alarm present.  |         |
| 3   | 0 | Alarm "converter overload" (low active)<br>Alarm W10 present ( $I^2t$ value of the power section too high)   | 26      |
|     | 1 | No alarm present.  |         |
| 4   | 0 | Converter cooling faulted (low active)<br>The conditions for fault message F110 are fulfilled.   | 27      |
|     | 1 | Converter cooling is not faulted   |         |
| 5   | 0 | $I_{\text{field}} < I_{\text{fmin}}$ (low active)<br>Field curr. actual value (K265) < threshold $I_{\text{fmin}}$ (P394) + hysteresis (P395).   | 28      |
|     | 1 | Field curr. actual value (K265) > threshold $I_{\text{fmin}}$ (P394)   |         |
| 6   | 0 | $I_{\text{aset}} = I_{\text{limit}}$<br>The armature current setpoint has not reached the actual current limit (K131 or K132).   | 29      |
|     | 1 | Armature current setpoint has reached the actual current limit (K131 or K132).   |         |
| 7   | 0 | Field contactor 1 OFF  | 30      |
|     | 1 | Field contactor 1 ON   |         |
| 8   | 0 | Field contactor 2 OFF  | 31      |
|     | 1 | Field contactor 2 ON   |         |
| 9   | 0 | Torque direction signal changed from SW2.00<br>Torque direction MII or no torque direction (--) has been selected or the drive is ready for selection, torque direction MII.                             | 32      |
|     | 1 | Torque direction MI or no torque direction (--) has been selected or the drive is ready for selecting, torque direction MI.  |         |
| 10  | 0 | Power section hot<br>The calculated equivalent barrier junction temperature rise is <5% of its maximum permissible value, the power section is considered "cold".  | 33      |
|     | 1 | The calculated equivalent barrier junction temperature rise is >5% of its maximum permissible value, the power section is considered "warm".   |         |
| 11  |   | Output of the freely-configurable limit value monitor 1 from SW2.00<br>Function can be parameterized with P692 (P659, P660, P693)  | 34      |
| 12  |   | Output of the freely-configurable limit value monitor 2 from SW2.00<br>Function can be parameterized with P694 (P670, P671, P695)  | 35      |
| 13  |   | Reserved for use later   |         |
| 14  |   | Reserved for use later   |         |
| 15  |   | Reserved for use later   |         |



## 10.7 Serial interfaces

The basic converter has two serial interfaces: G-SST0 and G-SST1.

Basic converter interface 0 (G-SST0) at the 9-pin SUBMIN D socket connector X500 is a RS485 interface.

Basic converter interface 1 (G-SST1) at the 9-pin SUBMIN D socket X501 is an RS232 interface.

By connecting the optional interface expansion (A1618 supplementary board) at G-SST1, the periphery has, instead of the RS232 interface, a second RS485 interface.

pin assignment of the interfaces, refer to "terminal assignment" in Section 6.9, connecting cable, refer to Section 10.7.5).

|                                 | G-SST0   |                   | G-SST1  | G-SST1 <sup>1)</sup>   |                   |
|---------------------------------|--|-------------------|---|--|-------------------|
| Type                            | RS485  |                   | RS232   | RS485 <sup>1)</sup>  |                   |
| Connector                       | X500   |                   | X501  | X502 <sup>1)</sup>   |                   |
| Oper. mode <sup>2)</sup>        | 4-wire operation:                                  | 2-wire operation: | RS232<br>(hardware or software handshake can be set using P798) | 4-wire operation:  | 2-wire operation: |
|                                 | bus capable <sup>4)</sup>                          | bus capable       |   | not bus capable  | not bus cap.      |
|                                 |  |                   | Insert XJ2, XJ6, XJ7, XJ8 on A1600 in setting 1-2               | Insert XJ2, XJ6, XJ7, XJ8 on A1600 for operation with A1618 in setting 2-3 |                   |
| Cable termination <sup>3)</sup> | yes: XJ3 in setting 2-3<br>XJ4, XJ5 in setting 1-2 |                   | not possible  | yes: XJ201 in setting 2-3<br>XJ200, XJ202 in setting 1-2                   |                   |
|                                 | no: XJ3 in setting 1-2<br>XJ4, XJ5 in setting 2-3  |                   |   | no: XJ201 in setting 1-2<br>XJ200, XJ202 in setting 2-3                    |                   |

- 1) With the interface expansion option (A1618 supplementary board for converting RS232 (converter-side) to RS485)
- 2) Interface functions with P051 = 11, 12, 13, 14, 15, 16, 17, 18 and 23 as well as the diagnostics monitor (P780 or P790 = xxx9) and the "peer-to-peer" coupling (P780 or P790 = xxx5) are not bus-capable, and automatically switch the interface to 4-wire operation. The "peer-to-peer" bus coupling (P780 or P790 = xxx4) automatically switches the RS485 interface to 2 wire operation, and, in conjunction with the binary input function "master/slave drive changeover" (BEF41) is also bus capable. The USS protocol (P780 or P790 = xxx2) automatically switches the interface to 2-wire operation.
- 3) 2-wire operation: The cable termination should only be activated for both converters, at both ends of the bus cable.  
4-wire operation: Cable termination should be activated at both receivers, which are at the end of both ends of the bus cable.
- 4) The hardware is bus-capable, 4-wire bus operation is presently not used by any of the protocols, which can be selected at P780.

The grey shaded areas at the intersection of an X500 function with an X501 function in the following diagram indicates that this combination is possible.

**Function overview and combination possibilities of the serial interfaces:**

| X501<br>(RS232)   | X500<br>(RS485) | Print-out of the changed parameters | Print-out of all parameters | Diagnostics print-out after a fault message | Trace buffer print-out for diagnostics | Parameter output of changed parameters at the PC/PG | Parameter output of all parameters at the PC/PG | Output of fault diagnostics memory after a fault at PC/PG | Output of the trace buffer at the PC/PG | Read-in parameter set from PC/PG | Peer-to-peer communications | USS protocol | Diagnostics monitor |
|---|-----------------|-------------------------------------|-----------------------------|---|--|---|---|---|---|----------------------------------|-----------------------------|--------------|---------------------|
| Print-out of the changed parameters                       |                 |                                     |                             |   |  |   |   |   |   |                                  |                             |              |                     |
| Print-out of all parameters                               |                 |                                     |                             |   |  |   |   |   |   |                                  |                             |              |                     |
| Diagnostics print-out after a fault message               |                 |                                     |                             |   |  |   |   |   |   |                                  |                             |              |                     |
| Trace buffer print-out for diagnostics                    |                 |                                     |                             |   |  |   |   |   |   |                                  |                             |              |                     |
| Parameter output of changed parameters at the PC/PG       |                 |                                     |                             |   |  |   |   |   |   |                                  |                             |              |                     |
| Parameter output of all parameters at the PC/PG           |                 |                                     |                             |   |  |   |   |   |   |                                  |                             |              |                     |
| Output of fault diagnostics memory after a fault at PC/PG |                 |                                     |                             |   |  |   |   |   |   |                                  |                             |              |                     |
| Output of the trace buffer at the PC/PG                   |                 |                                     |                             |   |  |   |   |   |   |                                  |                             |              |                     |
| Read-in parameter set from PC/PG                          |                 |                                     |                             |   |  |   |   |   |   |                                  |                             |              |                     |
| Peer-to-peer communications *)                            |                 |                                     |                             |   |  |   |   |   |   |                                  |                             |              |                     |
| USS protocol *)   |                 |                                     |                             |   |  |   |   |   |   |                                  |                             |              |                     |
| Diagnostics monitor                                       |                 |                                     |                             |   |  |   |   |   |   |                                  |                             |              |                     |

\*) for RS232 operation, only point-to-point communications is possible when using the interface expansion option A1618, also bus communication

## Activating an interface:

|   | G-SST0<br>X500<br>RS485 | G-SST1<br>X501/X502<br>RS232/485 |
|---|-------------------------|----------------------------------|
| 1. Setting the transmission rate  | P783                    | P793                             |
| 2. Setting the transmission protocol  | P780                    | P790                             |
| 3. Setting the handshake mode<br>*) for optional supplementary board A1618: P798 = 1        | No                      | P798 *)                          |
| 4. For P780 or P790 = xxx1, the required function must be set and started at parameter P051 |                         |                                  |

**WARNING**

An interface fault/error (e.g. due to an incorrectly set data frame, by switching-off a connected printer with the interface selected, etc.) causes an operational drive to be shutdown. If in doubt, the interface should not be used in the "RUN" operating status.

### 10.7.1 Output of the parameter list, fault diagnostics memory and trace buffer

The actual converter parameterization and the contents of the diagnostics- and trace buffer (also refer to Section 10.10) can be transferred to a printer with RS232- or RS485 interface or to a PC or PG.

#### Transfer to a printer

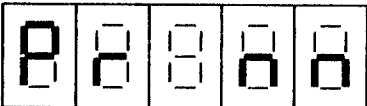
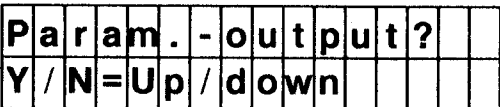
|     |  | G-SST0<br>X500<br>RS485 | G-SST1<br>X501/X502<br>RS232/485                               |
|-----|--|-------------------------|--|
|     | The values set at the 6RA24 converter must match the printer data. Please refer to the Operating Instructions of the printer for printer settings.   |                         | Refer to Sec. 10.7.5, Fig. 1 for an examp. of connecting cable |
| 1.  | Setting the transmission rate  | P783                    | P793   |
| 2.  | Setting the transmission protocol (function can be selected via P051)  | P780 = xxx1             | P790 = xxx1  |
| 3.  | Setting the handshake mode<br>*) when using the optional A1618 supplementary board, only software handshake is possible (P798 = 1)   | automatic<br>XON/XOFF   | P798 *)  |
| 4.  | Select the required function   |                         |  |
| 4.1 | Print-out changed parameters   | P051 = 11               | P051 = 11  |
| 4.2 | Print-out all existing parameters  | P051 = 12               | P051 = 12  |
| 4.3 | Print-out the fault/error diagnostic memory after a fault message has occurred   | P051 = 13               | P051 = 13  |
| 4.4 | Print-out the trace buffer for diagnostic purposes   | P051 = 14               | P051 = 14  |
| 5.  | Operator prompting appears after pressing the SELECT or P key with the required parameter value:<br><br>Simple control panel:<br><br><br>Converter operator control panel:<br> |                         |  |
| 6.  | The print-out is started by depressing the RAISE key again and print-out can be aborted by depressing the LOWER key.<br>Printing can be aborted during data transfer by depressing the LOWER key.  |                         |  |



#### WARNING



An interface fault/error (e.g. due to an incorrectly set data frame, by switching-off a connected printer with the interface selected, etc.) causes an operational drive to be shutdown. If in doubt, the interface should not be used in the "RUN" operating status.

## Transfer to a PC (PG)

Reading-in on the PC side can be realized, for example using the PCIN V2.0 program.

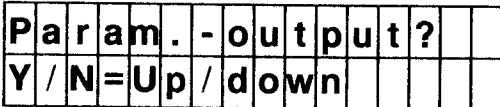
|     |  | G-SST0<br>X500<br>RS485   | G-SST1<br>X501/X502<br>RS232/485  |
|-----|--|---|---|
|     | Establish the connection between the 6RA24 converter and PC (PG)   | Example for connecting cable, refer to Section 10.7.5 Fig. 4 or 5 | Example for connecting cable, refer to Section 10.7.5 Fig. 2 and Bild 4, 5 or 7 |
| 1.  | Set the transmission rate  | P783  | P793  |
| 2.  | Set the transmission protocol (function can be selected via P051)  | P780 = xxx1   | P790 = xxx1   |
| 3.  | Select the handshake mode<br>*) When using the optional A1618 supplementary board, only software handshake is possible (P798 = 1)  | automatic<br>XON/XOFF   | P798 *)   |
| 4.  | Select the required function   |   |   |
| 4.1 | Output changed parameters  | P051 = 15   | P051 = 15   |
| 4.2 | Output all existing parameters   | P051 = 16   | P051 = 16   |
| 4.3 | Output the fault diagnostic memory after a fault message occurs  | P051 = 17   | P051 = 17   |
| 4.4 | Output the trace buffer for diagnostic purposes  | P051 = 18   | P051 = 18   |
| 5.  | Operator prompting appears after depressing the SELECT- or P key with the required parameter value<br><br>Simple control panel:<br><br><br><br>Converter operator control panel:<br><br> |   |   |
| 6.  | Start the PCIN program   |   |   |
| 7.  | Set the interface parameter at the PC/PG with <F5>installation <F3>interface<br><br>PCIN must be configured as follows for the standard setting P790 = 1181:<br><br>Baud rate      9600<br>Parity          even<br>Data bits       7<br>Stop bits       1  |   |   |
| 8.  | From the main menu select <F3>file functions<F4>receive and specify a file name. The PC is ready to receive after <RETURN>.  |   |   |
| 9.  | Data transmission is started when the RAISE key is depressed again; data transmission can be aborted using the LOWER key.<br>During data transmission, printing can be aborted by depressing the LOWER key.  |   |   |
| 10. | The PC ready-to-receive status is terminated when the end ID is received "40 x 0H", and the parameter set is stored under the specified name.<br>If data transmission is manually terminated, the data set received up until then can be stored by depressing key <F8>.  |   |   |
| 11. | The SIMOREG converter is then in the parameter mode for P051 = 0.  |   |   |

The output is realized as follows:

```
ID(% T E A 1)
Header with software version number
3 CR/LF
Parameter block
End ID "###" (for read-in again)
End ID "40 x 0H"
```

The PCIN program is flagged that the end of the data set has been received by the character sequence 40 x 0H.

### 10.7.2 Reading-in parameters

Parameters can be sent, for example from a PC with the PCIN V2.0 interface program.

The function is selected via P051 = 23

Parameters from the serial interface are read-in and transferred as long as the following syntax is maintained:

- 1 Data receive is activated by three consecutively received LF- or CR/LF characters. Everything else prior to this is ignored (e.g. header).
- 2 The actual parameter declaration is then in the following form:  
[x] Pyyy [ . ii] = vvv [ . nn] with the following significance:
  - x Optional page number; if it is missing, page 0 is assumed.
  - yyy Parameter number; this must be specified as a three-digit number (if required with leading 0's).
  - ii Optional, two-digit index number (possibly with leading 0's).
  - = The "=" character can be specified separately from the parameter number and parameter value any number of <blanks> or not separated.
  - vvv Parameter value; for NIBBLE-coded parameters, the number of digits must be correct. Decimal parameters can be specified as required.
  - nn Number of decimal places for decimal parameters (00 is assumed if not specified)
- 3 Two parameters are separated by blanks, /, and -, CR, CR/LF or any combination of these.
- 4 Read-in is terminated after three consecutively received "#" characters, the RTS line is reset again, and P051 = 0, parameter mode selected.

#### NOTE

The electronics power supply MUST be kept switched-on for at least 3 minutes after data transfer has been completed so that the new values can be transferred into the EEPROM (with the EEPROM memory memory inhibit not activated, refer to P053 in Section 9.2).

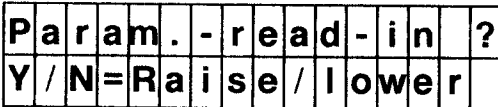
|     |  | G-SST0<br>X500<br>RS485   | G-SST1<br>X501/X502<br>RS232/485  |
|-----|--|---|---|
|     | Establish the connection between the 6RA24 converter and PC (PG)   | Example for connecting cable, refer to Section 10.7.5 Fig. 4 or 5 | Example for connecting cable, refer to Section 10.7.5 Fig. 2 and Fig. 4, 5 or 7 |
| 1.  | Set the data transmission rate   | P783  | P793  |
| 2.  | Set the transmission protocol (function can be selected via P051)  | P780 = xxx1   | P790 = xxx1   |
| 3.  | Set the handshake mode<br>*)when using the optional A1618 supplementary board, only software handshake is possible (P798 = 1)  | automatisch<br>XON/XOFF   | P798 *)   |
| 4.  | Select the required function   |   |   |
| 4.1 | Read-in the parameter block from the PG  | P051 = 23   | P051 = 23   |
| 5.  | Operating prompting after the select- or P key is depressed with the required parameter value:<br><br>Simple control panel:<br><br><br>Converter operator control panel:<br> |   |   |
| 6.  | Set the interface parameter at the PC/PG with <F5> installation <F3> interface<br>PCIN must be configured as follows for the standard setting P790 = 1181:<br><br>Baud rate        9600<br>Parity            even<br>Data bits        7<br>Stop bits        1  |   |   |
|     | An activity display appears when the RAISE key is depressed again (vertical bars jumping from left to right on the simple operator control panel, and the "parameter-input" text, on the converter operator control panel).  |   |   |
| 7.  | Start the PCIN program and with <F3> file function <F6> send, select the required file, and start parameter transfer with <RETURN>.  |   |   |
| 8.  | The number of the received parameter is displayed.   |   |   |
| 9.  | Ready-to-receive status is terminated and a jump made to P051 after the end ID "###" has been received.  |   |   |
| 10. | If a parameter set is transmitted without end ID or, when required, data transmission to the SIMOREG converter can be aborted by depressing the LOWER key.   |   |   |
| 11. | If a syntax or value range violation occurs during data transmission, fault F013 (or F023) is output at the end of transmission. The fault cause (word 0), the last valid received parameter (word 1) and the last valid parameter number before the last error (word 2) was received, can be read in the fault diagnostics memory (P047).       |   |   |



## WARNING

After data transfer has been completed, it can take up to 3 minutes until all parameters are stored in the EEPROM. It is not permissible that the electronics power supply is switched-out during this time. "read-in parameter" must be repeated if it is switched-off!

### 10.7.3 USS protocol

The USS protocol is implemented according to the following documentation:

"Specification of the universal serial interface protocol" E31930-T9011-X-A1

"Application of the universal serial interface protocol" E31930-T9012-X-A2

Special features for 6RA24 converters:

|  | E31930-T9012-X-A2 |
|--|-------------------|
|  | Section           |
| - All data in the 6RA24 converters transmitted via the interface are word length   | 2                 |
| - All process data can be freely parameterized   | 2                 |
| - The factory setting for the telegram failure time monitoring (P797) is 0, i.e. monitoring is disabled                            | 3.1               |
| - The setting, PKW length <3 means no PKW  | 4.1.1             |
| - Variable telegram length always results in 3 words in the response protocol (read PBE and read text has still not been realized) | 4.1.2             |
| - There are two converter-specific fault IDs:  | 4.2.1.1           |
| 101 task not implemented   |                   |
| 102 parameter is the array type  |                   |
| - All interfaces can change parameters at any time, there are no "parameter change rights"   | 4.2.1.1           |
| - The "request PBE" task results in the response "error occurred", code 101  | 4.2.2             |
| - "Request text" task results in the response "error occurred", code 101   | 4.2.2             |
| - Bit 10 of the control word (control from the PLC) is not evaluated   | 5.2.1             |

## CAUTION

Only a limited number of EEPROM write accesses are guaranteed within its lifetime (10,000).

Thus, frequent parameter value changes via the interfaces (serial basic converter interfaces or cyclic parameter value changes via supplementary board) should, if possible only be realized in the RAM, and not in the EEPROM.

The "change parameter value (and not store in the EEPROM)" task is available for parameter changes via the interface (if the value is only changed in the RAM, the thus changed values are lost when the electronics power supply is switched-off).



## USS protocol

## Short start-up for 6RA24 converters

|  | G-SST0<br>X500<br>RS485   | G-SST1<br>X501/X502<br>RS232/485  |
|--|---|---|
| Baud rate  | P783 = 1 to 10 corresponds to 300 to 187500 baud<br>Factory setting: 10 (187500 baud)   | P793 = 1 to 10 corresponds to 300 to 187500 baud<br>Factory setting: 6 (9600 baud)  |
| Protocol selection<br>1 stop bit, even parity, 9-bit data frame (8 data bits + 1 parity bit), USS protocol | P780 = 1192   | P790 = 1192   |
| Process data number (PZD number (valid for receive and transmit))  | P781 = 0 ... no PZD<br>to<br>16 ... PZD words<br>Factory setting: 0   | P791 = 0 ... no PZD<br>to<br>16 ... PZD words<br>Factory setting: 0   |
| PZD assignment for control word and setpoints (received process data)                                      | Process data can be connected via select parameters.<br>The received process data are assigned connector numbers:<br>PZD1 = K020<br>to<br>PZD16 = K035<br>Select parameter for the control word: P640 = 20 (1st receive data) | Process data can be connected via select parameters.<br>The received process data are assigned connector numbers:<br>PZD1 = K036<br>to<br>PZD16 = K051<br>Select parameter for the control word: P640 = 36 (1st receive data) |
| PKW quantity   | P782 = 0 to 2, no parameters are transferred<br>3 to 126 PKW words<br>127 variable length for slave → master<br>Factory setting: 0  | P792 = 0 to 2, no parameters are transferred<br>3 to 126 PKW words<br>127 variable length for slave → master<br>Factory setting: 3  |
| PZD assignment for actual values (transmitted process data)  | Every connector (actual value, status word) can be sent.<br>P784.00 = connector number of actual value 1<br>to<br>P784.15 = connector number of actual value 16<br>Factory setting: 0   | Every connector (actual value, status word) can be sent.<br>P794.00 = connector number of actual value 1<br>to<br>P794.15 = connector number of actual value 16<br>Factory setting: 0   |
| Node address   | P786 = 0 to 30<br>Factory setting: 0  | P796 = 0 to 30<br>Factory setting: 0  |
| Telegram failure time  | P787 = 0 to 32s (0, no time monitoring)<br>Factory setting: 1   | P797 = 0 to 32s (0, no time monitoring)<br>Factory setting: 0   |
| Bus-/point-to-point communication  | Bus operation is possible   | Only point-to-point operation is possible with RS232, bus operation is possible with the RS485 option   |
| 2-wire/4-wire data transfer of the RS485 interface   | "2-wire" operation is automatically selected  | "2-wire" operation is automatically selected.   |
| Cable (refer to Section 10.7.5)  | Use a cable according to Fig. 4 or Fig. 5.  | RS232<br>Use a cable acc. to Fig. 2.<br>RS485<br>Use a cable acc. to Fig. 4 or 5  |

## 10.7.4 "Peer-to-peer" protocol

### 10.7.4.1 "Peer-to-peer" communication (4-wire operation)

from SW1.10

The "peer-to-peer" protocol permits a serial link to be established from converter to converter.

#### Short start-up for 6RA24 converters

|   | G-SST0<br>X500<br>RS485   | G-SST1<br>X501/X502<br>RS232/485  |                                     |
|---|---|---|-------------------------------------|
| Baud rate   | P783 = 1 to 10 corresponds to 300 to 187500 baud<br>Factory setting: 10 (187500 baud)   | P793 = 1 to 10 corresponds to 300 to 187500 baud<br>Factory setting: 6 (9600 baud)  |                                     |
| Protocol selection<br>1 stop bit, even parity, 9-bit data frame (8 data bits + 1 parity bit), peer-to-peer protocol | P780 = 1195   | P790 = 1195   |                                     |
| Process data number (PZD number) (valid for receiving and sending)  | 5 data words are always transferred   | 5 data words are always transferred   |                                     |
| PZD assignment for control words and setpoints (received process data)  | Process data can be connected via select parameters. The received process data are assigned connector numbers:<br>PZD1 = K020<br>to<br>PZD5 = K024<br>Select parameter for STW: P640<br>Select parameter for STWF: P641 | Process data can be connected via select parameters. The received process data are assigned connector numbers:<br>PZD1 = K036<br>to<br>PZD5 = K040<br>Select parameter for STW: P640<br>Select parameter for STWF: P641 |                                     |
| PKW number  | No parameters can be transferred.   | No parameters can be transferred.   |                                     |
| PZD assignment for actual values (transmitted process data)   | Every connector (actual value, status word) can be sent. P784 defines the connectors to be sent.<br>P784.00 = Connector number actual value 1<br>to<br>P784.04 = Connector number actual value 5<br>Factory setting: 0  | Every connector (actual value, status word) can be sent. P784 defines the connectors to be sent.<br>P794.00 = Connector number actual value 1<br>to<br>P794.04 = Connector number actual value 5<br>Factory setting: 0  |                                     |
| Telegram failure time   | Time monitoring can be parameterized at P788 (when the time is exceeded, F015 activated)  | Time monitoring can be parameterized at P788 (when the time is exceeded, F025 activated)  |                                     |
| 2-wire/4-wire data transfer of the RS485 interface  | "4-wire" operation automatically selected   | "4-wire" operation automatically selected   |                                     |
| Cable (refer to Section 10.7.5)   | Use a cable according to Fig. 6.  | RS232<br>Use a cable acc. to Fig. 3   | RS485<br>Use a cable acc. to Fig. 6 |

## 10.7.4.2 "Peer-to-peer" bus communication (2-wire operation)

from SW2.00

The "peer-to-peer" bus protocol permits a serial link to be established with several converters through a common 2-wire bus cable in conjunction with the binary input function "changeover, master/slave drive" (BEF41), which defines the data transfer direction. Only one bus node may be the "master drive", all others must be "slave drives" (also refer to Section 10.3.41 for an application).

## Short-start-up for 6RA24 converters

|   | G-SST0<br>X500<br>RS485   | G-SST1<br>X501/X502<br>RS232/485  |
|---|---|---|
| Baud rate   | P783 = 1 to 10 corresponds to 300 to 187500 baud<br>Factory setting: 10 (187500 baud)   | P793 = 1 to 10 corresponds to 300 to 187500 baud<br>Factory setting: 6 (9600 baud)  |
| Protocol selection<br>1 stop bit, even parity, 9-bit data frame (8 data bits + 1 parity bit), peer-to-peer protocol | P780 = 1194   | P790 = 1194   |
| Process data number (PZD number) (valid for receiving and sending)  | 5 data words are always transferred   | 5 data words are always transferred   |
| PZD assignment for control words and setpoints (received process data)  | Process data can be connected via select parameters. The received process data are assigned connector numbers:<br>PZD1 = K020<br>to<br>PZD5 = K024<br>Select parameter for STW: P640<br>Select parameter for STWF: P641 | Process data can be connected via select parameters. The received process data are assigned connector numbers:<br>PZD1 = K036<br>to<br>PZD5 = K040<br>Select parameter for STW: P640<br>Select parameter for STWF: P641 |
| PKW number  | No parameters can be transferred.   | No parameters can be transferred.   |
| PZD assignment for actual values (transmitted process data)   | Every connector (actual value, status word) can be sent. P784 defines the connectors to be sent.<br>P784.00 = Connector number actual value 1<br>to<br>P784.04 = Connector number actual value 5<br>Factory setting: 0  | Every connector (actual value, status word) can be sent. P784 defines the connectors to be sent.<br>P794.00 = Connector number actual value 1<br>to<br>P794.04 = Connector number actual value 5<br>Factory setting: 0  |
| Telegram failure time   | Time monitoring can be parameterized at P788 (when the time is exceeded, F015 activated)  | Time monitoring can be parameterized at P788 (when the time is exceeded, F025 activated)  |
| 2-wire/4-wire data transfer of the RS485 interface  | "2-wire" operation automatically selected   | "4-wire" operation automatically selected   |
| Signal level of BEF41<br>Low ("master drive")<br>High ("slave drive")   | Send only<br>Receive only   | Send only<br>Receive only   |
| Cable (refer to Section 10.7.5)   | Use a cable according to Fig. 8.  | Use a cable according to Fig. 8.  |

10.7.5 Connecting cables

**Fig. 1: Connecting cable between a 6RA24 converter (X501) and a printer, e.g. HP thinkjet (RS232 version)**

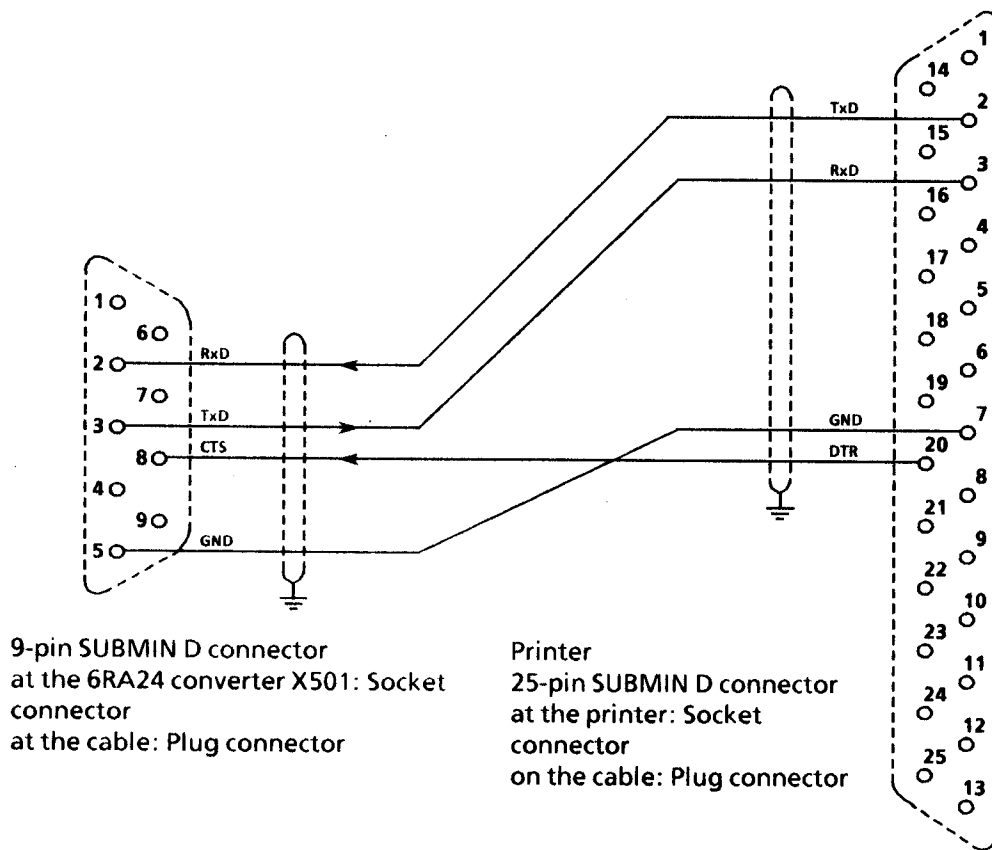

Hardware handshake (P798 = 2), as well as software handshake XON/XOFF (P798 = 1) is possible with such a cable.

**Fig. 2: Connecting cable between a 6RA24 converter (X501) and a PC**

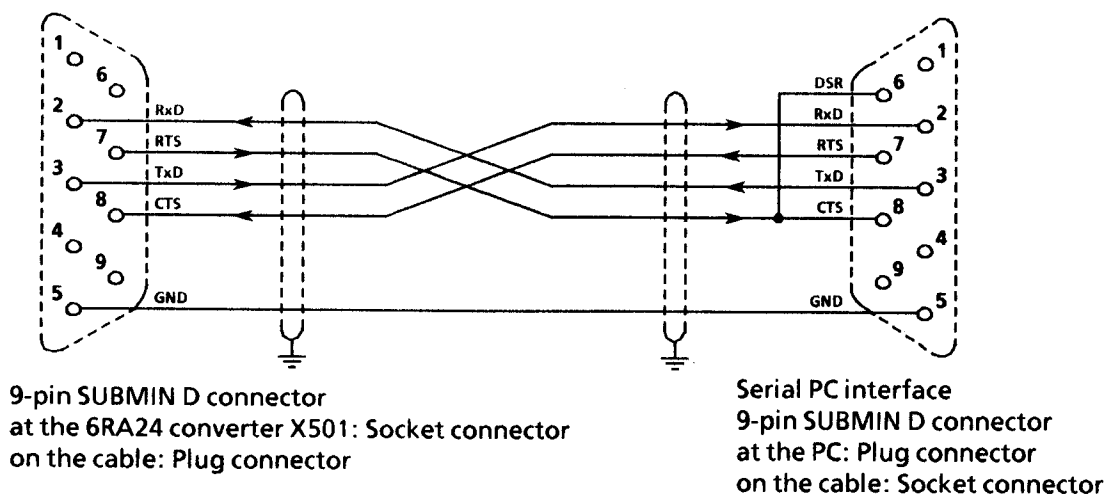

Hardware handshake (P798 = 2), as well as software handshake XON/XOFF (P798 = 1) is possible with such a cable.

**Fig. 3: Connecting cable between two 6RA24 converters (X501) for "peer-to-peer" communications (via a RS232 interface)**

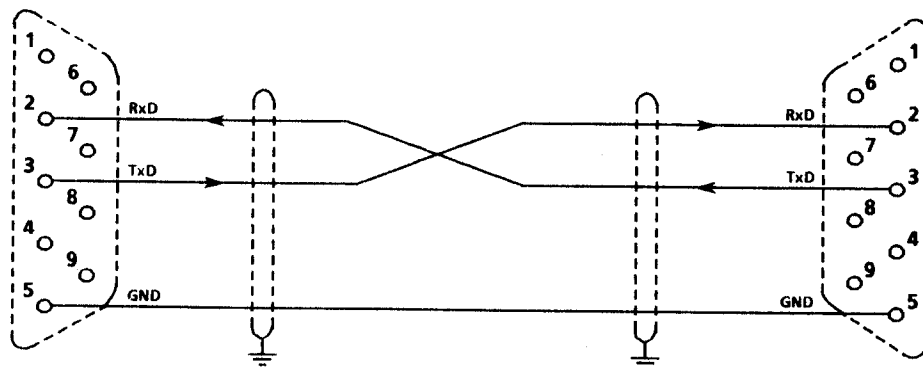

9-pin SUBMIN D connector  
at the 6RA24 converter X501: Socket connector  
on the cable: Plug connector

9-pin SUBMIN D connector  
at the 6RA24 converter X501: Socket connector  
on the cable: Plug connector

**Fig. 4: Connecting cable between the 6RA24 converter (X500 or X502) and the CP524 communications processor with RS485 interface module**

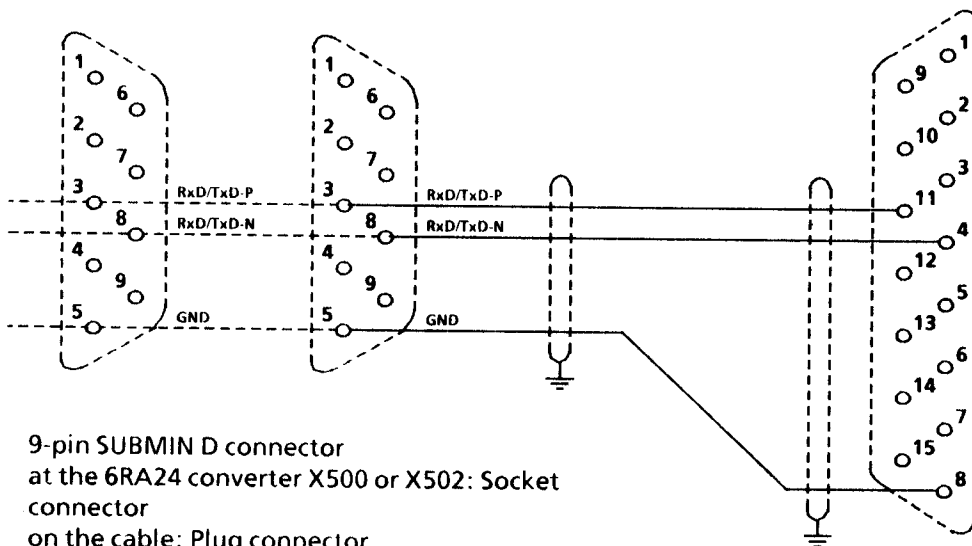

9-pin SUBMIN D connector  
at the 6RA24 converter X500 or X502: Socket connector  
on the cable: Plug connector  
Other nodes are connected in parallel  
in the same fashion.

CP 524 with RS485 interface module  
15-pin SUBMIN D connector  
at the CP524: Socket connector  
on the cable: Plug connector

**Fig. 5: Connecting cable between a 6RA24 converter (X500 or X502) and a PC with RS485 interface**

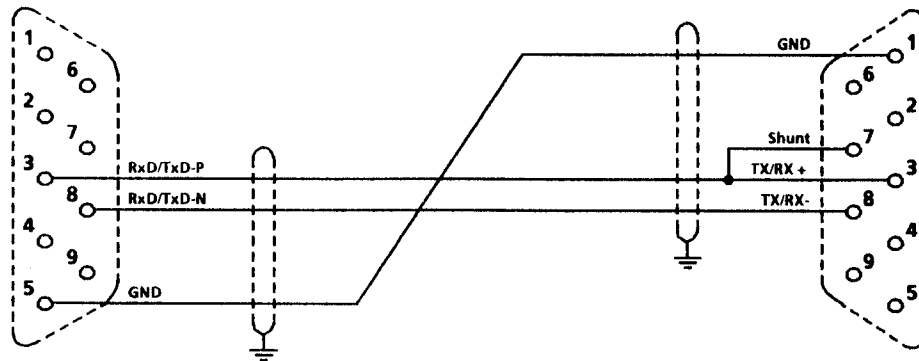

9-pin SUBMIN D connector  
at the 6RA24 converter X500 or X502:  
Socket connector  
on the cable: Plug connector

PC RS485 interface  
card, Messrs. Kolter  
9-pin SUBMIN D connector  
at the PC RS485 interface:  
Socket connector  
on the cable: Plug connector

**Fig. 6: Connecting cable between two 6RA24 converters (X500 or X502) for "peer-to-peer" communication (via RS485 interface)**

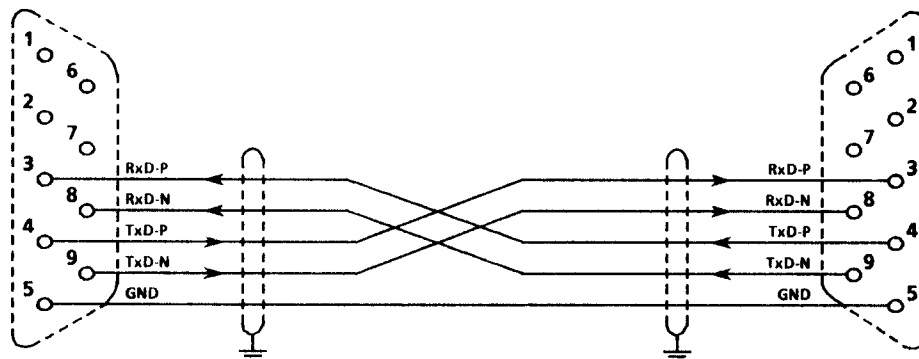

9-pin SUBMIN D connector  
at the 6RA24 converter X500 or X502:  
Socket connector  
on the cable: Plug connector

9-pin SUBMIN D connector  
at the 6RA24 converter X500 or X502:  
Socket connector  
on the cable: Plug connector

**Fig. 7: Connecting cable between 6RA24 converters (X501) and PG710 / PG730 / PG750 / PG770 (COM1) programming units**

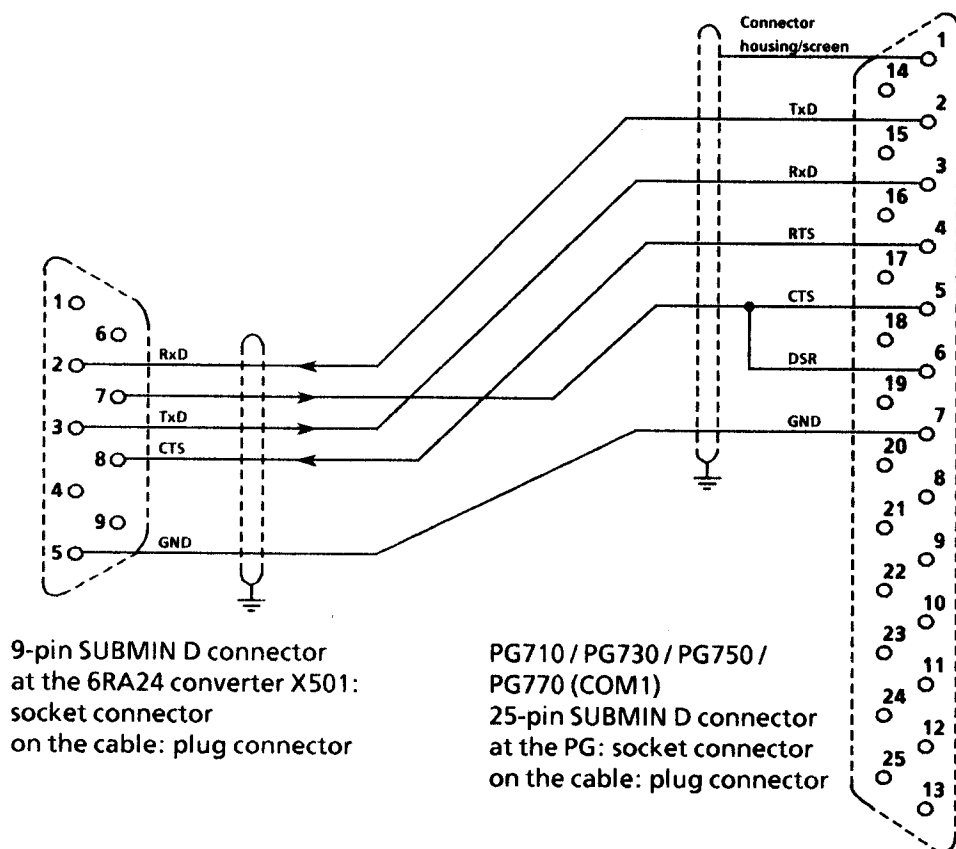

**Fig. 8: Bus cable between several 6RA24 converters (X500 or X502) for "peer-to-peer" bus communication (via RS485 interface)**

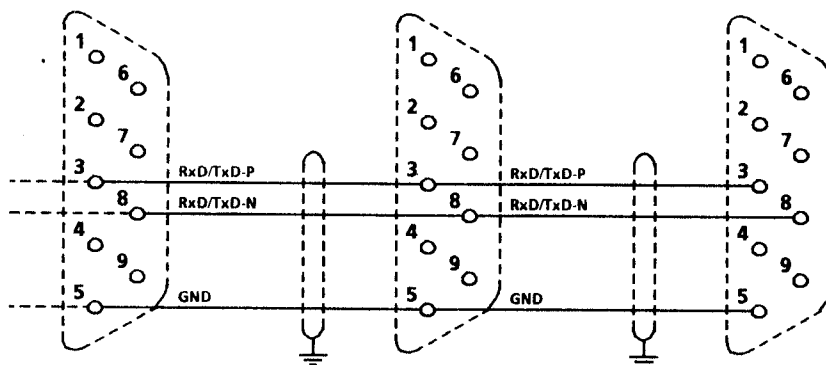

9-pin SUBMIN D connector at the 6RA24 converter X500 or X502: socket connector on the cable: Plug connector  
 Other bus nodes are connected in parallel in the same fashion.

## 10.8 DC motor thermal overload protection (I<sup>2</sup>t motor monitoring)

Parameters P100 and P114 are used for parameterizing the I<sup>2</sup>t monitoring. The motor is protected against inadmissible load conditions with the appropriate adaption (this does not constitute complete motor protection).

### Adaption

**P114:** A time constant  $T_{\text{motor}}$  must be entered in minutes in parameter P114 for the I<sup>2</sup>t monitoring

**P100:** The motor rated armature current in amps according to the rating plate must be set in parameter P100.

### Pre-alarm characteristic / shutdown characteristic

If the motor, is for example, constantly loaded with approximately 125% of the rated motor current, alarm W01 is issued after a time constant (P114) has expired. If the load is not reduced, the drive is shutdown when the trip characteristic is reached, and fault message F037 flashes. Pre-warning/trip times for other load conditions should be taken from the diagram.

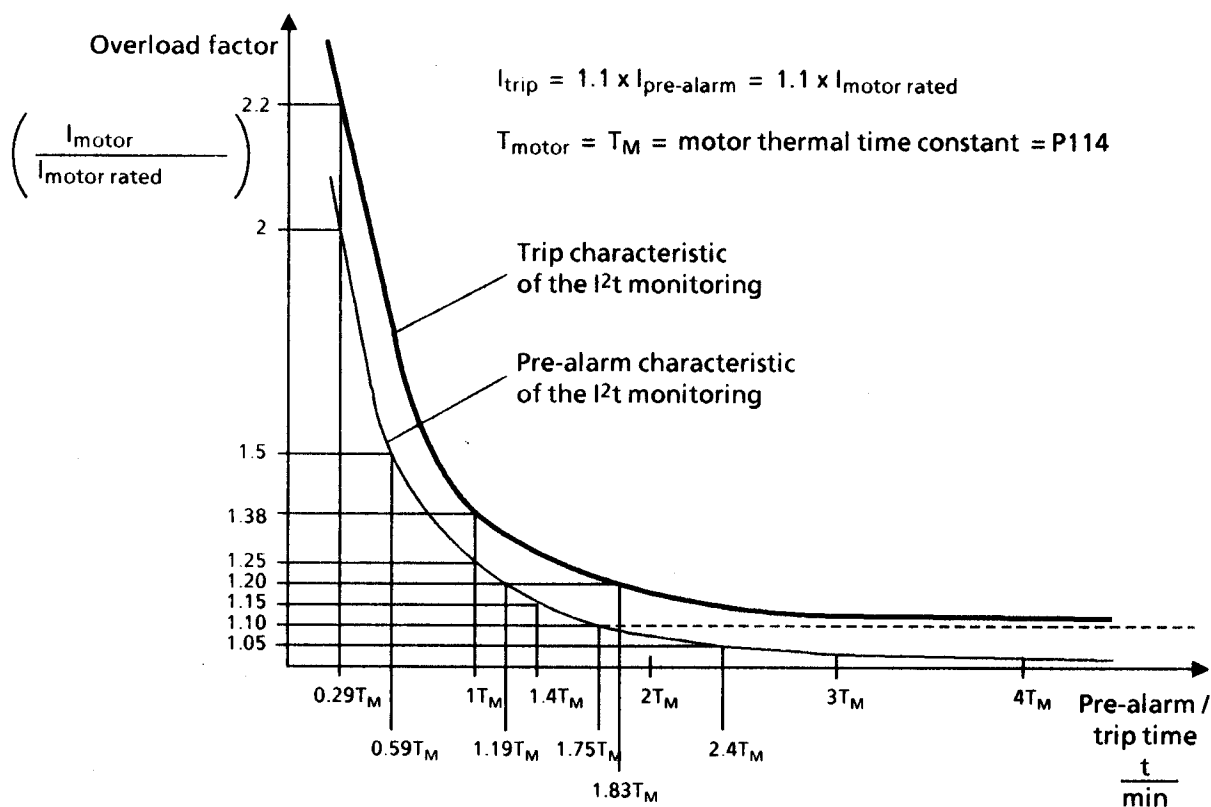

### NOTE

- The calculated motor pre-loading is lost if the electronics power fails for longer than 2 seconds. When the voltage returns, it is assumed that the motor was unloaded! If restart is realized within 2 seconds after the electronics power supply has failed (e.g. using the "automatic restart" function), then the last calculated I<sup>2</sup>t value of the motor is used.
- The I<sup>2</sup>t monitoring only provides a rough estimate of the motor thermal image (this does not constitute complete motor protection).
- I<sup>2</sup>t monitoring is disabled if the value in P114 ( $T_{\text{motor}}$ ) is set to zero.



### Determining the equivalent thermal time constant (P114)

It should be noted that the equivalent thermal time constant is dependent on the maximum overcurrent.

Refer to Catalog DA12 for the equivalent thermal time constants of 1G . 5/1H . 5 DC motors.

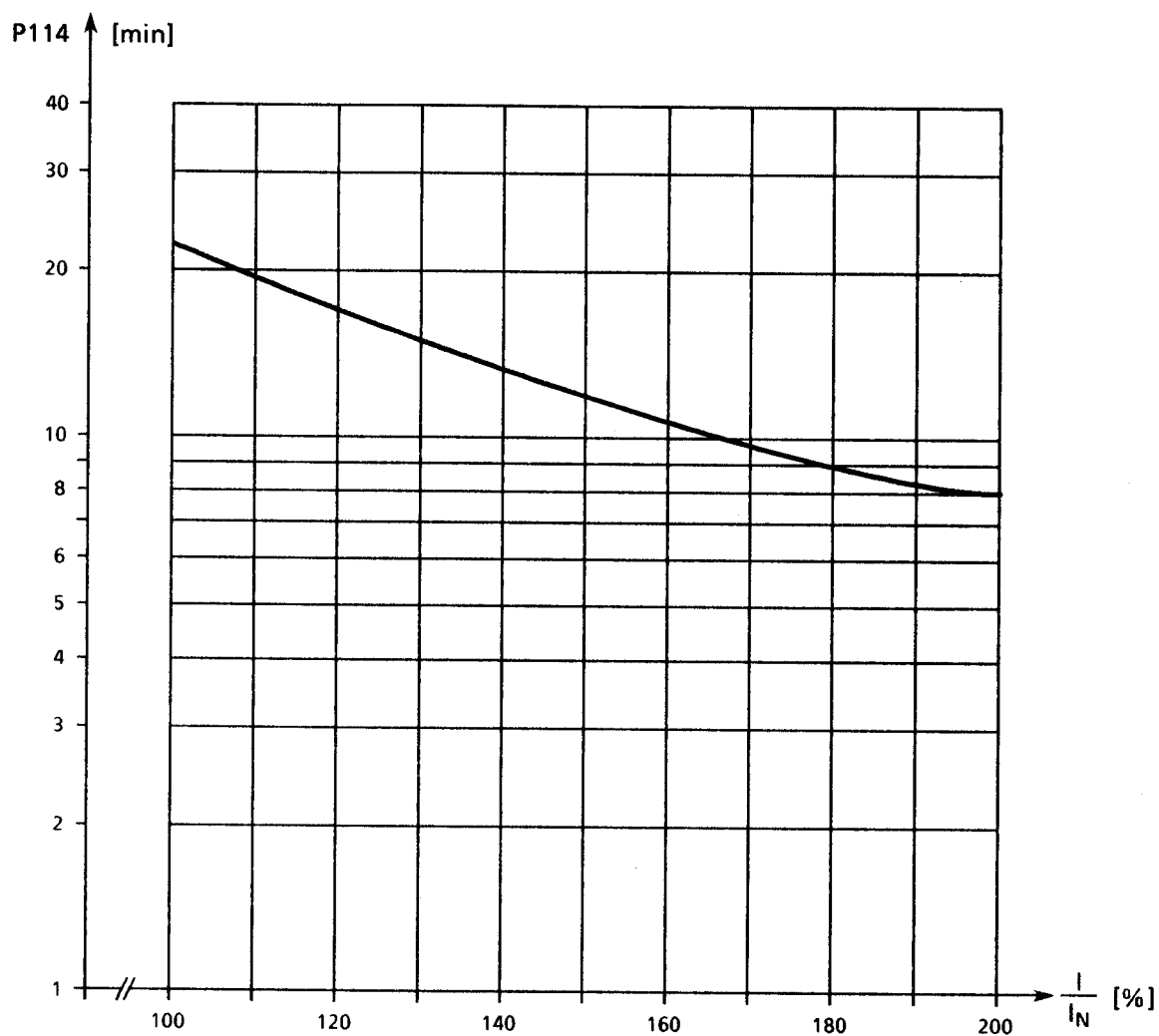

$I_N$  ... rated motor armature current (= P100)

$I$  ... maximum overcurrent with which the motor is operated

#### NOTE

When using other motor types, manufacturer's data should be observed.

## 10.9 Dynamic overload capability of the power section

### 10.9.1 Function overview

The rated converter DC current specified on the converter rating plate (= maximum permissible continuous DC current for  $P077 = 1.00$ ) may be exceeded in operation. The absolute value and duration of the overload are limited and are discussed in more detail in the following.

The absolute upper limit for the absolute value of the overload currents is 150% of the rated converter current \*  $P077$ . The maximum overload duration is dependent on the time characteristics of the overload current and the converter overload condition prior to this which is converter-specific.

A reduced load phase must always precede every overload condition (phase with load current  $< P077 * \text{rated converter current}$ ). After the maximum permissible overload duration has expired, the load current must be reduced to a value  $\leq P077 * \text{rated converter DC current}$ .

The dynamic overload duration is made possible by thermal monitoring ( $I^2t$  monitoring) of the power section. The  $I^2t$  monitoring calculates, from the load current actual value characteristics (over time) the characteristics of an equivalent value for the barrier junction temperature rise of the thyristors above the ambient temperature. Converter-specific characteristics (eg. thermal resistance and time constants) are used in the calculation. When the converter is switched-on, the calculation starts with those initial values, which were determined before the last shutdown/supply failure. From SW2.00, the environmental conditions (ambient temperature, installation altitude, parallel unit) can be taken into account by setting parameter  $P077$ .

As supplied, the maximum permissible value is always based on the ambient temperature (i.e. 45°C for self-cooled converters and 35°C for force-ventilated converters).

The  $I^2t$  monitoring responds if the calculated equivalent barrier junction temperature rise exceeds the permissible value.

Two responses can be parameterized:

- alarm with reduction of the armature current setpoint to  $P077 * \text{rated converter DC current}$
- fault with converter trip

The  $I^2t$  monitoring can be disabled. In this case, the armature current is limited to  $P077 * \text{rated converter DC current}$ .

Connector K310 contains the calculated equivalent barrier junction temperature rise as a % of the maximum permissible, converter-specific barrier junction temperature rise:

80°C for 15A to 60A converters

85°C for 90A to 140A converters

90°C for converters  $> 200A$  rated converter armature DC current.

The response threshold for the  $I^2t$  monitoring response is converter-specific and lies below the maximum permissible barrier junction overtemperature specified above.

### 10.9.2 Parameterization

The characteristics of the  $I^2t$  monitoring are set using parameter  $P075$ .

Refer to  $P075$ , Section 9.2 "Parameter description" for possible settings.

### 10.9.3 Configuring the dynamic overload capability

The configuring sheets, in Section 10.9.4, contain the following information:

- The maximum overload duration  $t_{an}$  when accelerating with the power section in the cold condition and specified constant overload
- The maximum no-current interval  $t_{ab}$  (maximum cooling time), until the power section reaches the cold condition.
- Limiting characteristic fields to determine the overload capability for thermally, stabilized intermittent overload operation (periodic duty cycles).

Note:

The power section is considered "cold" if the calculated equivalent barrier junction temperature rise is less than 5% of its maximum permissible value. This status can be interrogated via a binary select output.

Note:

If duty cycles are started with the power section in the cold condition and at least just within the specified duty cycle limits, the thermally stabilized condition is reached without the  $I^2t$  monitoring function responding.

If the  $I^2t$  monitoring function is parameterized for shutdown ( $P075 = 12$ ), when configuring periodic duty cycles with a duty cycle duration greater, just less or equal to 300 s, the limits should not be approached too close.

In all other cases, especially when parameterizing the  $I^2t$  monitoring to reduce the armature current setpoint ( $P075 = 02$ ), it is possible to fully utilize the maximum overload capability defined by the limiting characteristic.

Structure of the limiting characteristic fields for intermittent overload duty:

The limiting characteristic fields refer to a duty cycle of intermittent overload duty with a total duration (period) of 300 s. Such a duty cycle consists of two time sectors, the base load time (armature current actual value  $\leq P077 * \text{rated DC converter}$ ) and the overload time (armature current actual value  $\geq P077 * \text{rated converter DC current}$ ).

Each limiting characteristic represents, for a specified converter, the maximum base load current for a specific overload factor (limiting base load current, specified as a % of the rated converter current) over the minimum base load time (limiting base load time). For the remaining duration of the duty cycle, the maximum value of the overload current is defined by the overload factor.

If a limiting characteristic is not specified for the required overload factor, the limiting characteristic for the next higher overload factor should be used.

The limiting characteristic group of curves is valid for a load duty cycle of 300 s. Using simple calculation techniques, load duty cycles with load duty durations of  $\geq 300$  s can be configured. This is illustrated in the following using 2 basic tasks.

Designations:    Base load duration<sub>300</sub> = minimum base load duration for 300s duty cycle time  
                           Overload duration<sub>300</sub> = maximum overload duration for 300s duty cycle time

Note:

The following configuring characteristics are valid for  $P077 = 1.00$ . For a parameterization  $P077 \neq 1.00$ , i.e. for reduced thermal loading, the actual currents must be evaluated with the factor  $1 / P077$ :

Overload factor x for characteristic = 
$$\frac{\text{Actual overload current}}{P077 * \text{rated DC converter current}}$$

Actual maximum base load current =  $P077 * \text{maximum base load current according to the characteristic as a \% of the rated DC converter current}$

**Basic task 1:**

Given: Converter, duty cycle time, overload factor, overload duration  $< 300s$

Required: (Minimum) base load duration and maximum base load current

Solution: To select the limiting characteristic for the specified converter and the specified overload factor

Duty cycle time  $< 300s$ :

Overload duration<sub>300</sub> = (300s/ duty cycle time) x overload duration

Base load duration<sub>300</sub> = 300s – overload duration<sub>300</sub>

Base load duration<sub>300</sub>  $<$  base load duration<sub>300</sub> for maximum base load current = 0 (Limiting characteristic)  $\rightarrow$  required duty cycle cannot be configured, otherwise: Read-off the maximum base load current for the base load duration<sub>300</sub> from the limiting characteristic

Duty cycle time  $\geq 300s$ :

Base load duration<sub>300</sub> = 300s – overload duration

Base load duration<sub>300</sub>  $<$  base load duration<sub>300</sub> for maximum base load current = 0 (Limiting characteristic)  $\rightarrow$  required duty cycle cannot be configured, otherwise: Read-off the maximum base load current for the base load duration<sub>300</sub> from the limiting characteristic

**Example 1:**

Given: 30A/4-quadrant converter; duty cycle time 113.2s; overload factor = 1.45; overload duration = 20s

Required: (Minimum) base load duration and maximum base load current

Solution: Limiting characteristic for 30A/4-quadrant converter, overload factor 150%

Overload duration<sub>300</sub> = (300s/113.2s) x 20s = 53s

Base load duration<sub>300</sub> = 300s – 53s = 247s  $\rightarrow$

Maximum base load current = 49%  $I_N$  = 14.71A

**Basic task 2:**

Given: Converter, duty cycle time, overload factor, base load current

Required: To determine the minimum base load duration and associated maximum overload time

Solution: Select the limiting characteristic for the specified converter and the specified overload factor

Read-off the base load duration<sub>300</sub> for the base current from the limiting characteristic

Duty cycle time  $< 300s$ :

Min. base load duration = (duty cycle time/300s) x base load duration<sub>300</sub>

Max. overload duration = duty cycle time – min. base load duration

Duty cycle time  $\geq 300s$ :

Max. overload duration = 300s – base load duration<sub>300</sub>

Min. base load duration = duty cycle time – max. overload duration

**Example 2:**

Given: 30A/4-quadrant converter; duty cycle time 140s; current overload factor = 115%; base load current = 0.6  $I_N$  = 18A

Required: Minimum base load duration and associated maximum overload duration

Solution: Limiting characteristic for 30A/4-quadrant converter, overload factor 120%

Base load current = 60%  $I_N$   $\rightarrow$  base load duration<sub>300</sub> = 148s

Min. base load duration = (140s/300s) x 148s = 69s

Max. overload duration = 140s – 69s = 71s

### 10.9.4 Determining the dynamic overload capability for intermittent overload operation from the characteristic

Information for configuring the dynamic overload capability

Example: 6RA24/30A/4Q

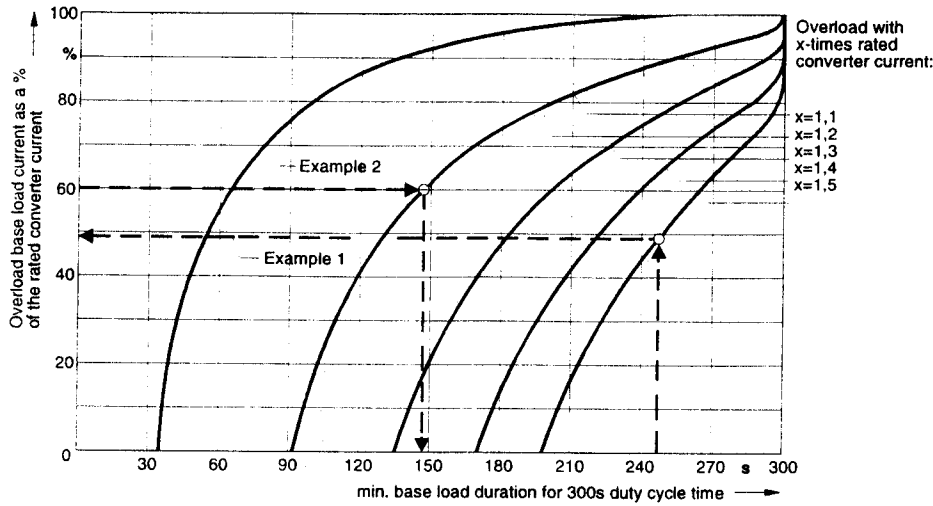

| x   | t <sub>an</sub> (s) |
|-----|---------------------|
| 1.1 | 1586.38             |
| 1.2 | 894.58              |
| 1.3 | 605.84              |
| 1.4 | 433.04              |
| 1.5 | 314.90              |

t<sub>ab</sub> = 1717.84s

Information for configuring the dynamic overload capability for 6RA24/15A/4Q

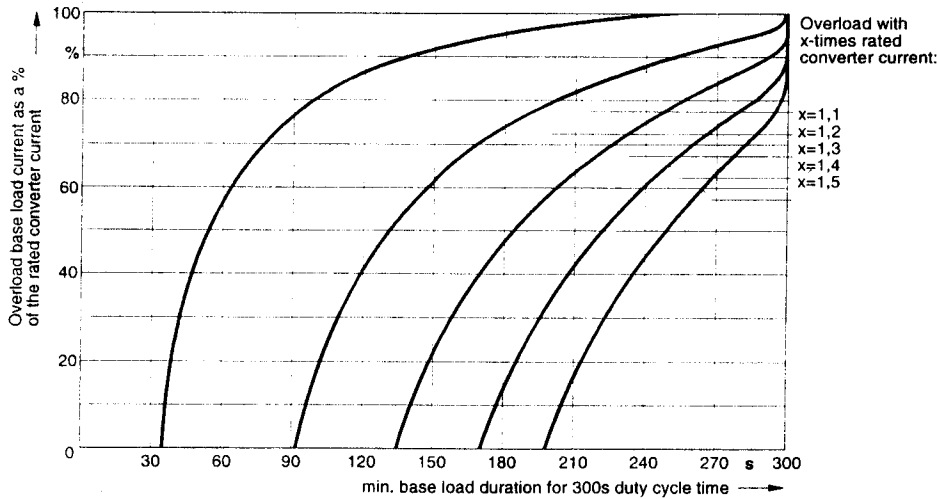

| x   | t <sub>an</sub> (s) |
|-----|---------------------|
| 1.1 | 1586.38             |
| 1.2 | 894.58              |
| 1.3 | 605.84              |
| 1.4 | 433.04              |
| 1.5 | 314.90              |

t<sub>ab</sub> = 1717.84s

Information for configuring the dynamic overload capability for 6RA24/30A/1Q

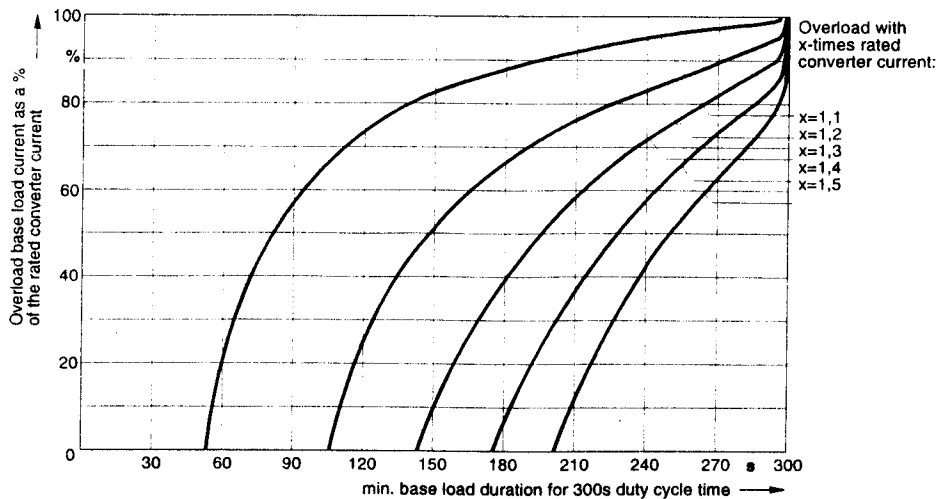

| x   | t <sub>an</sub> (s) |
|-----|---------------------|
| 1.1 | 1058.86             |
| 1.2 | 654.42              |
| 1.3 | 459.10              |
| 1.4 | 336.78              |
| 1.5 | 251.16              |

t<sub>ab</sub> = 1406.08s

Information for configuring the dynamic overload capability for 6RA24/30A/4Q

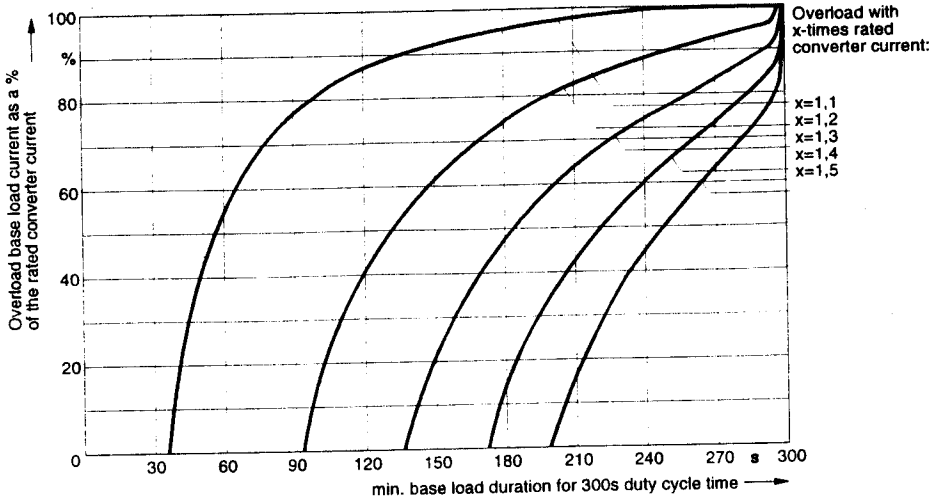

| x   | $t_{an}$ (s) |
|-----|--------------|
| 1.1 | 1586.38      |
| 1.2 | 894.58       |
| 1.3 | 605.84       |
| 1.4 | 433.04       |
| 1.5 | 314.90       |

$t_{ab} = 1717.84s$

Information for configuring the dynamic overload capability for 6RA24/60A/1Q

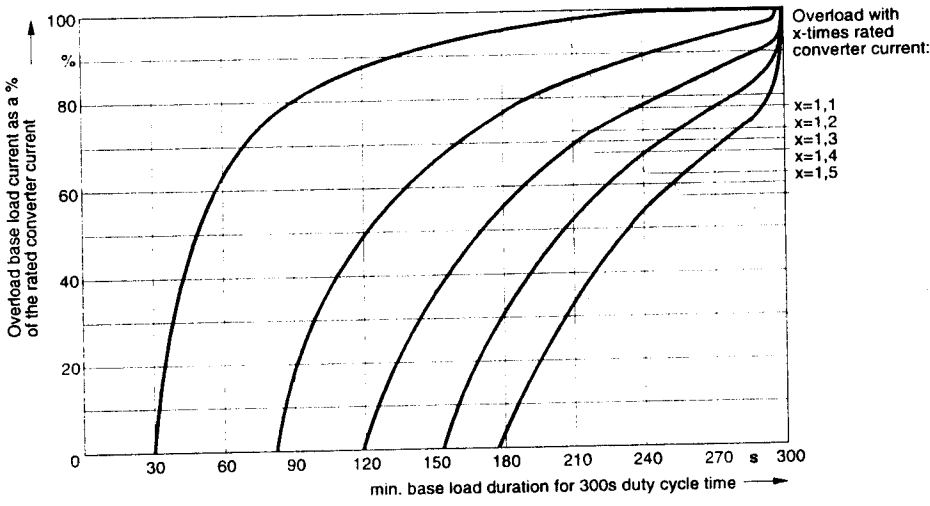

| x   | $t_{an}$ (s) |
|-----|--------------|
| 1.1 | 2104.04      |
| 1.2 | 1230.94      |
| 1.3 | 862.74       |
| 1.4 | 640.50       |
| 1.5 | 487.40       |

$t_{ab} = 2195.18s$

Information for configuring the dynamic overload capability for 6RA24/60A/4Q

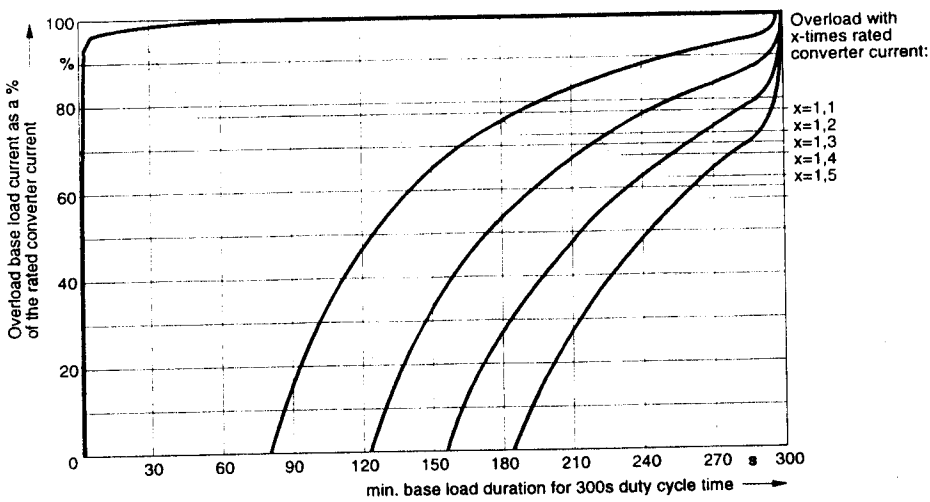

| x   | $t_{an}$ (s) |
|-----|--------------|
| 1.1 | 2551.54      |
| 1.2 | 1472.92      |
| 1.3 | 1018.22      |
| 1.4 | 743.84       |
| 1.5 | 554.86       |

$t_{ab} = 2598.84s$

Information for configuring the dynamic overload capability for 6RA24/90A/1Q

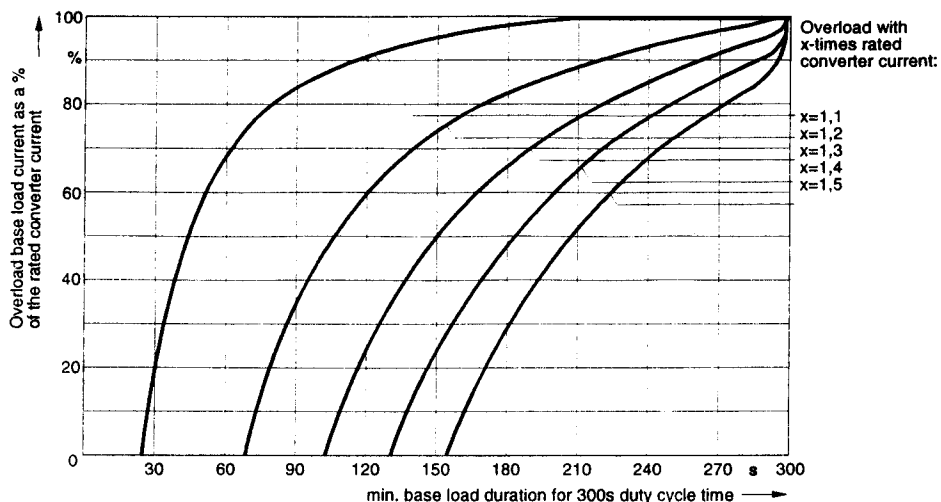

| x   | $t_{an}$ (s) |
|-----|--------------|
| 1.1 | 2247.64      |
| 1.2 | 1373.10      |
| 1.3 | 1003.58      |
| 1.4 | 780.10       |
| 1.5 | 625.82       |

$t_{ab} = 2295.46s$

Information for configuring the dynamic overload capability for 6RA24/100A/4Q

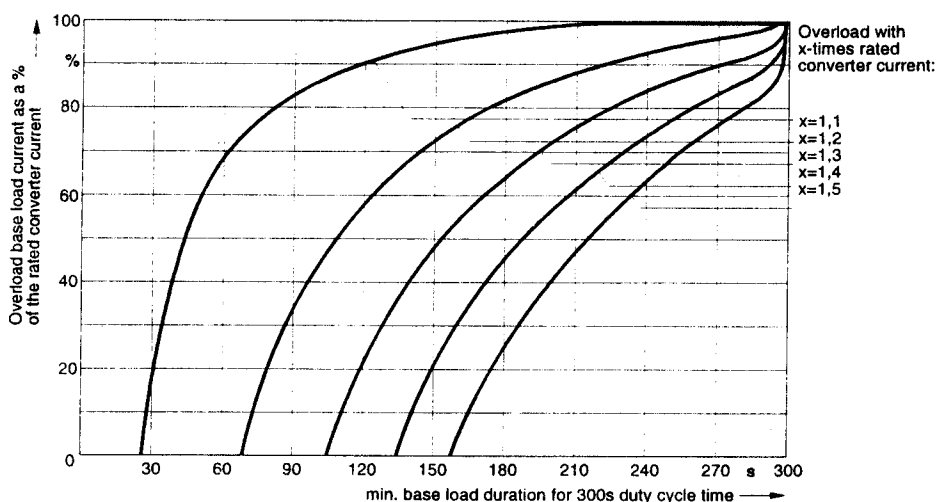

| x   | $t_{an}$ (s) |
|-----|--------------|
| 1.1 | 2731.12      |
| 1.2 | 1650.50      |
| 1.3 | 1194.02      |
| 1.4 | 918.04       |
| 1.5 | 727.58       |

$t_{ab} = 2855.90s$

Information for configuring the dynamic overload capability for 6RA24/125A/1Q

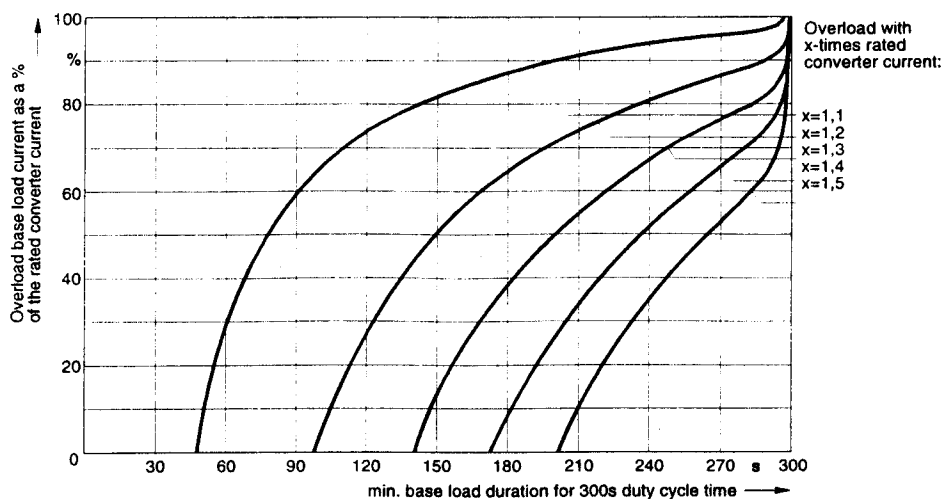

| x   | $t_{an}$ (s) |
|-----|--------------|
| 1.1 | 1874.48      |
| 1.2 | 1141.64      |
| 1.3 | 787.34       |
| 1.4 | 564.60       |
| 1.5 | 408.02       |

$t_{ab} = 2397.00s$

Information for configuring the dynamic overload capability for 6RA24/140A/4Q

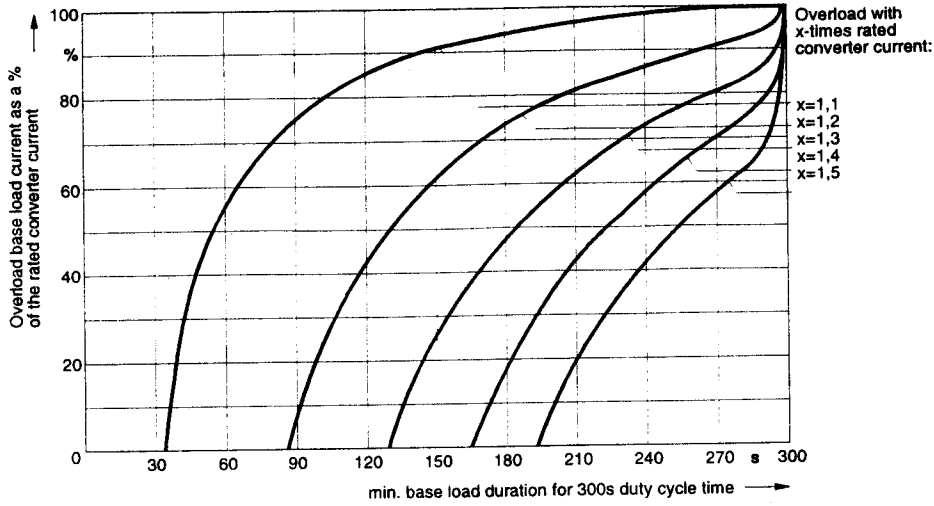

| x   | $t_{an}$ (s) |
|-----|--------------|
| 1.1 | 2337.42      |
| 1.2 | 1345.34      |
| 1.3 | 918.96       |
| 1.4 | 660.38       |
| 1.5 | 481.88       |

$t_{ab} = 2561.08s$

Information for configuring the dynamic overload capability for 6RA24/200A/1Q

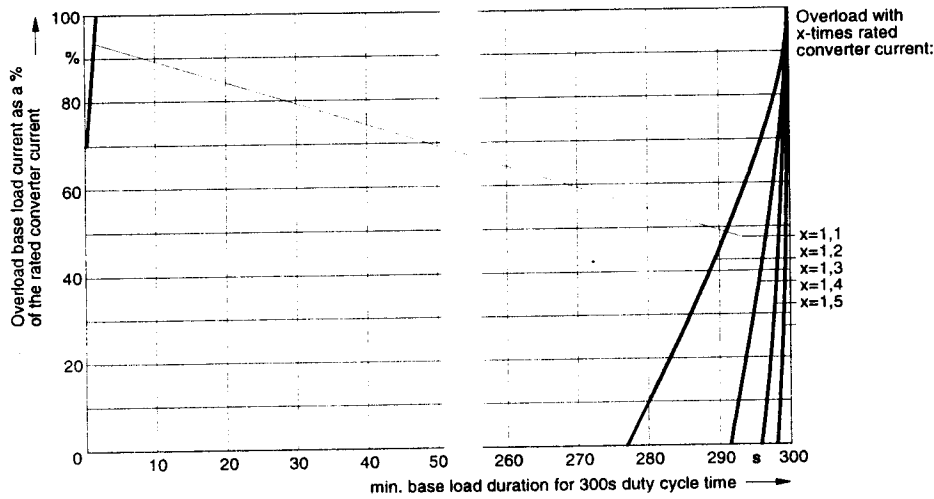

| x   | $t_{an}$ (s) |
|-----|--------------|
| 1.1 | 123.62       |
| 1.2 | 21.86        |
| 1.3 | 7.38         |
| 1.4 | 3.76         |
| 1.5 | 2.20         |

$t_{ab} = 136.62s$

Information for configuring the dynamic overload capability for 6RA24/200A/4Q

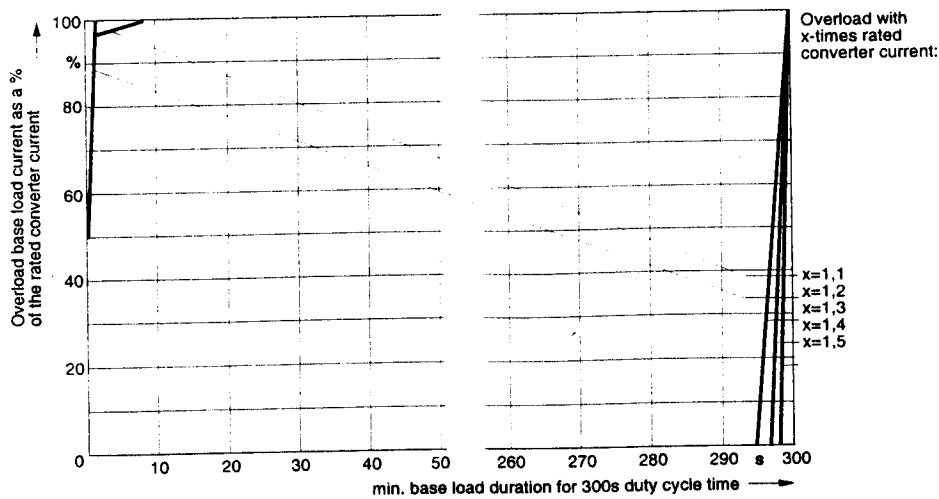

| x   | $t_{an}$ (s) |
|-----|--------------|
| 1.1 | 140.38       |
| 1.2 | 14.00        |
| 1.3 | 3.24         |
| 1.4 | 1.40         |
| 1.5 | 0.76         |

$t_{ab} = 140.26s$



Information for configuring the dynamic overload capability for 6RA24/250A

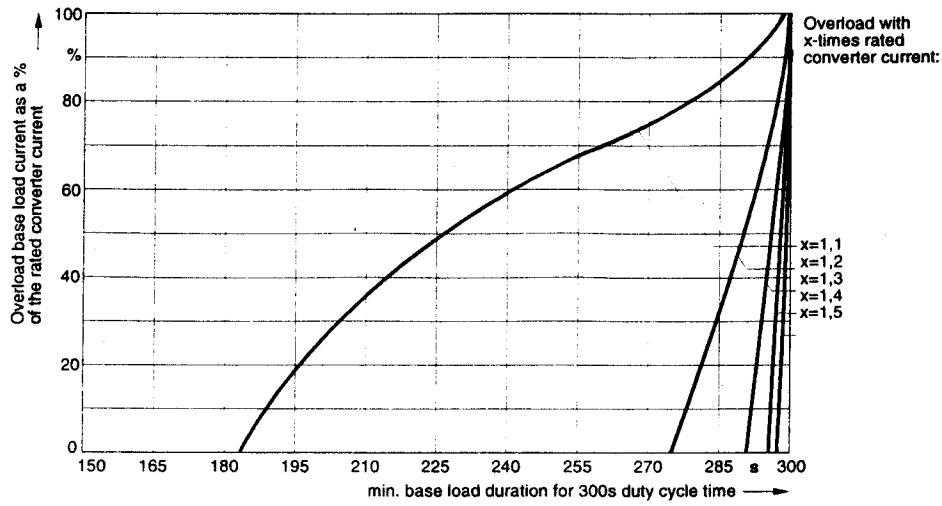

| x   | t <sub>an</sub> (s) |
|-----|---------------------|
| 1.1 | 127.16              |
| 1.2 | 23.80               |
| 1.3 | 8.04                |
| 1.4 | 4.10                |
| 1.5 | 2.42                |

t<sub>ab</sub> = 153.94s

Information for configuring the dynamic overload capability for 6RA24/400A/1Q

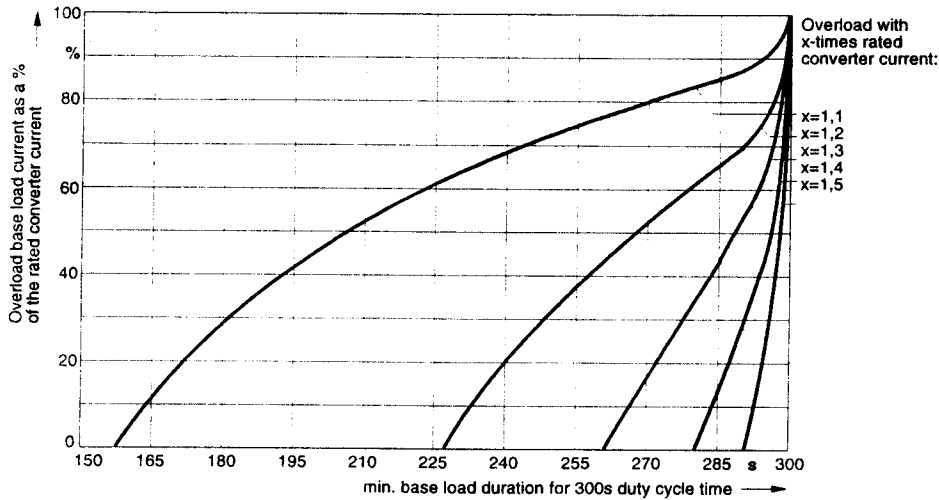

| x   | t <sub>an</sub> (s) |
|-----|---------------------|
| 1.1 | 211.22              |
| 1.2 | 87.14               |
| 1.3 | 40.92               |
| 1.4 | 18.88               |
| 1.5 | 8.50                |

t<sub>ab</sub> = 405.78s

Information for configuring the dynamic overload capability for 6RA24/400A/4Q

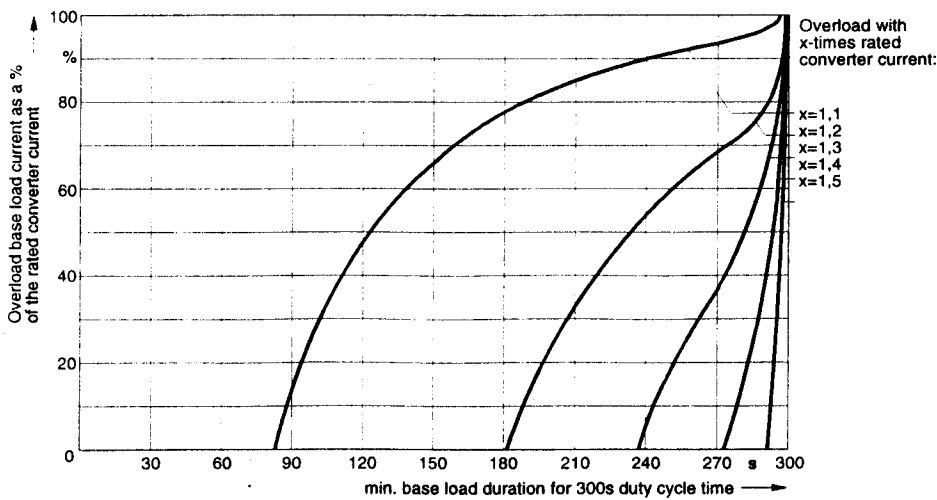

| x   | t <sub>an</sub> (s) |
|-----|---------------------|
| 1.1 | 528.00              |
| 1.2 | 184.74              |
| 1.3 | 82.62               |
| 1.4 | 29.46               |
| 1.5 | 8.00                |

t<sub>ab</sub> = 616.16s

Information for configuring the dynamic overload capability for 6RA24/600A/1Q

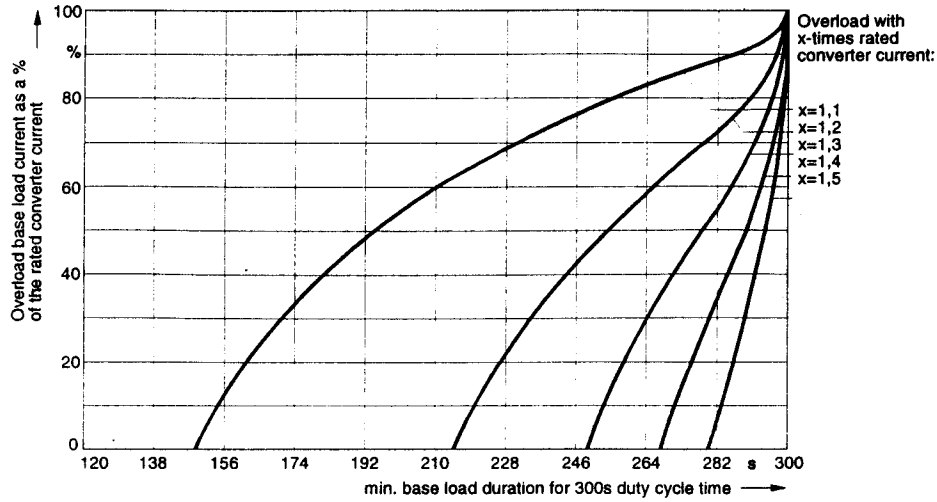

| x   | t <sub>an</sub> (s) |
|-----|---------------------|
| 1.1 | 198.32              |
| 1.2 | 98.56               |
| 1.3 | 55.16               |
| 1.4 | 32.36               |
| 1.5 | 19.26               |

t<sub>ab</sub> = 339.40s

Information for configuring the dynamic overload capability for 6RA24/600A/4Q

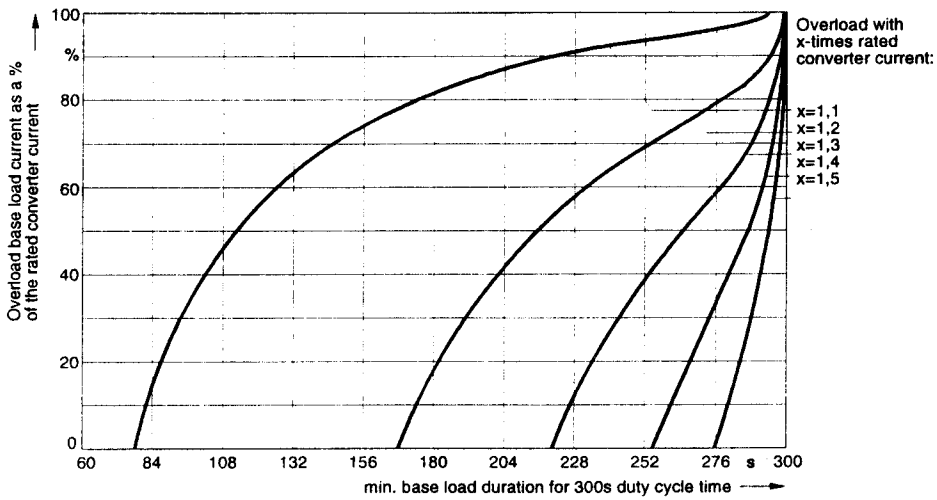

| x   | t <sub>an</sub> (s) |
|-----|---------------------|
| 1.1 | 396.78              |
| 1.2 | 189.96              |
| 1.3 | 103.52              |
| 1.4 | 53.80               |
| 1.5 | 25.34               |

t<sub>ab</sub> = 443.22s

Information for configuring the dynamic overload capability for 6RA24/640A

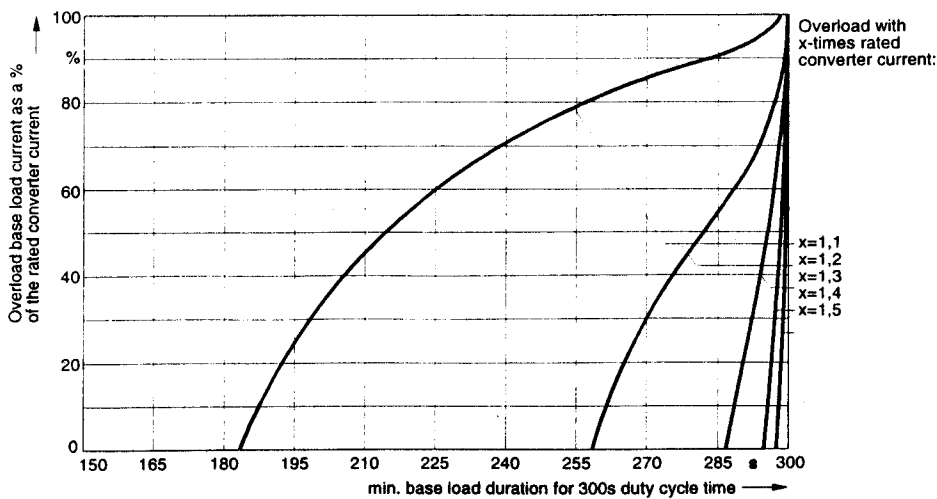

| x   | t <sub>an</sub> (s) |
|-----|---------------------|
| 1.1 | 129.14              |
| 1.2 | 40.62               |
| 1.3 | 11.76               |
| 1.4 | 4.44                |
| 1.5 | 1.98                |

t<sub>ab</sub> = 167.58s

Information for configuring the dynamic overload capability for 6RA24/850A

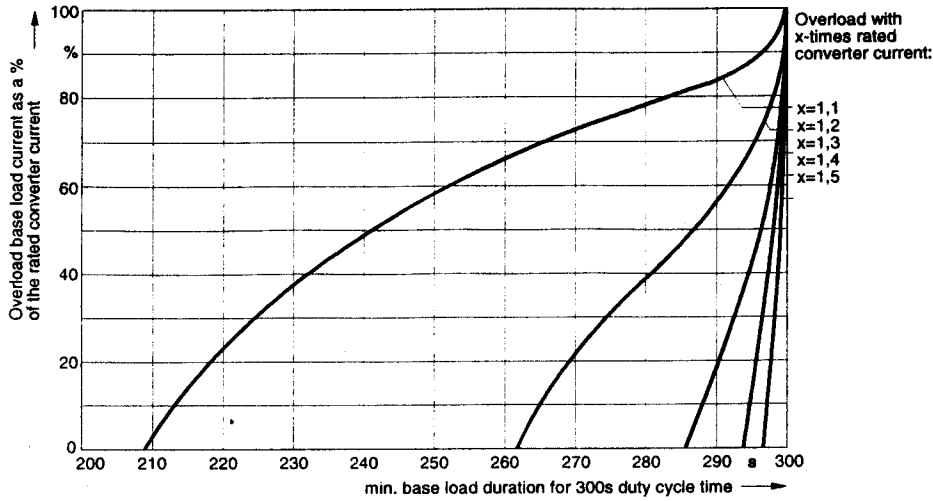

| x   | $t_{an}$ (s) |
|-----|--------------|
| 1.1 | 96.08        |
| 1.2 | 36.88        |
| 1.3 | 12.62        |
| 1.4 | 5.32         |
| 1.5 | 2.78         |

$t_{ab} = 167.88s$

Information for configuring the dynamic overload capability for 6RA24/860A

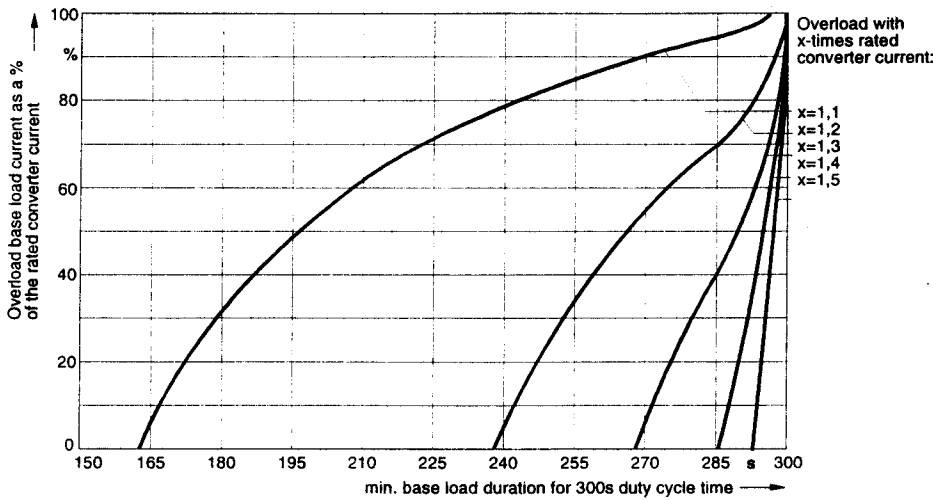

| x   | $t_{an}$ (s) |
|-----|--------------|
| 1.1 | 162.30       |
| 1.2 | 62.96        |
| 1.3 | 30.06        |
| 1.4 | 12.94        |
| 1.5 | 6.52         |

$t_{ab} = 193.10s$

Information for configuring the dynamic overload capability for 6RA24/1200A

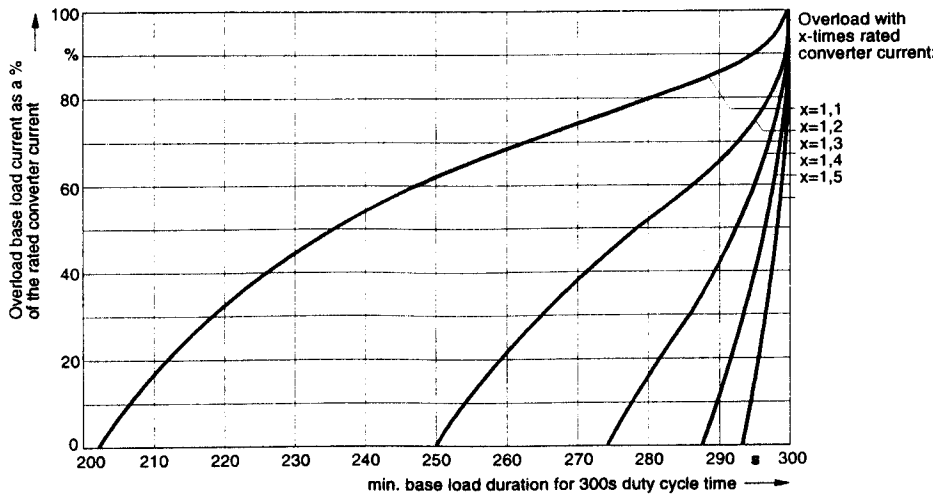

| x   | $t_{an}$ (s) |
|-----|--------------|
| 1.1 | 106.34       |
| 1.2 | 49.92        |
| 1.3 | 24.50        |
| 1.4 | 11.16        |
| 1.5 | 6.14         |

$t_{ab} = 209.28s$

## 10.10 Recording connectors in a trace buffer as an aid to diagnostics

The values from a maximum of 8 connectors can be recorded over a specific time for diagnostics. These values are stored in the trace buffers. Recording can be started via P867, and terminated when specific trigger conditions have been fulfilled.

The sampling intervals can be defined using P865 between 1 value line per 60° electrical (3.3 ms at 50 Hz, i.e. recording in each firing pulse cycle) and one value line per  $99 \times 60^\circ = 5940^\circ$  electrical (330 ms at 50 Hz, i.e. recording at each 99th firing pulse cycle).

The values which have been recorded can be printed-out, or transferred to a PC or a PG, read-out on an operator control panel, or output as analog voltages at the analog select outputs.

|                                     |   |
|-------------------------------------|---|
| Trace buffer depth:                 | 128x8 values = 128 lines, each 8 connectors                       |
| Connectors to be recorded:          | can be parameterized using P861.ii, starting with ii = 1          |
| Trigger condition:                  | adjustable using P862, P863, P864                                 |
| Sampling:                           | can be parameterized using P865 (in 60 degree steps)              |
| Length before and after the event : | can be parameterized using P866 (in 60 degree steps)              |
| Start of recording:                 | set P867 to 1 (activate trigger)                                  |
| Stopping the recording:             | when the trigger condition has been fulfilled or P867 is set to 0 |

Recording:

1. Set all conditions for recording (P861.ii to P866)
2. Start recording using P867 = 1  
When the trigger condition has been fulfilled and the recording has been terminated, P867 is automatically reset to 0.

Caution:

If this sequence is not maintained, the trigger instant (P849) is not calculated!  
P849 is also incorrect if recording is manually terminated by setting P867 to 0!

Trigger condition examples:

| P862        | P863                  | P864          | P865                         | P866                            |   |
|-------------|-----------------------|---------------|------------------------------|---------------------------------|---|
| 123<br>K123 | 2<br>>                | 10,0<br>10.0% | 1<br>60 degrees<br>sampling  | 10<br>10 lines<br>post<br>event | Trigger as soon as the value of connector K123 is > 10.0%. A value line is recorded every 60 degrees, whereby 10 lines are recorded after the trigger condition has been fulfilled. |
| any         | 3<br>Fault<br>message | any           | 6<br>360 degrees<br>sampling | 5<br>5 lines<br>post<br>event   | Trigger as soon as an error occurs. A value line is recorded every 6 x 60 degrees, whereby 5 lines are recorded after the trigger condition has been fulfilled.                     |

**Note:**

All connectors of a record value line are simultaneously recorded shortly after the firing pulse output. The recorded connectors associated with a value line can also be assigned to various firing cycles (i.e. the previous or last but one cycle). For example, the values, assigned to a specific firing pulse cycle, of the armature current controller setpoint (K119), armature current controller output (K110) or armature firing angle (K100) can be shifted by one firing cycle with respect to the firing pulse cycle duration (K388) or the operating status (K300) and by two firing cycles with respect to the values of the speed actual value (K167), armature current actual value (K114), EMF actual value (K287) or armature voltage actual value (K292).

### 10.10.1 Output of values recorded in the trace buffer on a printer or transfer to a PC or a PG

The values are output in 128 lines, each 8 columns, which corresponds to the 8 recorded connector values. The line, with line number 0 in this case, corresponds to values, where the trigger condition was fulfilled for the first time.

**Example:**

P866 was selected to be 70 in the following example. Thus, after the trigger condition was fulfilled, 70 lines of "post event" were recorded, starting with line 0.

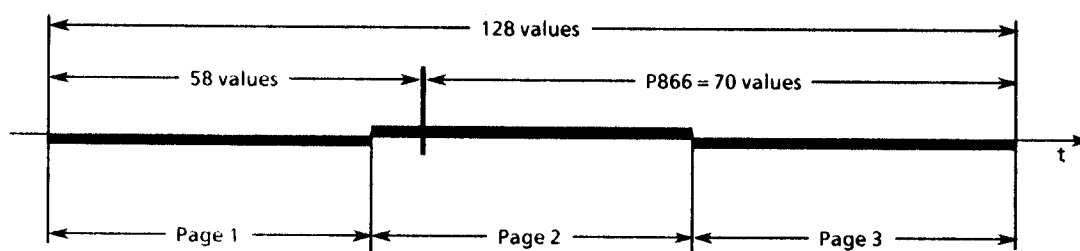

50 lines per page are printed-out, whereby print-out starts at line - 58 due to P866 = 70. The complete print-out with 128 lines is approximately 2.5 pages long, and ends, in the example, with line 69.

Procedure, refer to Section 10.7.1

### 10.10.2 Reading-out the contents of the trace buffer via the operator control panel

from SW2.00

If the values are to be read-out via the operator control panel, it should be observed that the values of interest lie, when recording, between index = 0 and index = 99 of P841.ii to P848.ii. Only then can it be accessed via P841.ii to P848.ii. This can be realized by suitably selecting P866 (trigger delay) and P865 (sampling interval). For example P866 = 77 can be selected and in this case the trigger instant lies at index = 50 ( $127 - 77 = 50$ ). Thus, for each connector, selected with P861.ii, 50 values can be read-out before and after the trigger condition has been fulfilled. After recording has been completed, the trigger instant can also be read at P849. (If recording was manually aborted using P867 = 0, the value of P849 is incorrect!). If the recording time period is too short, this can be extended, by not recording at every firing pulse cycle ( $P865 \neq 1$ ).

At the end of recording ( $P867 = 0$ ), P840 indicates how many values per connector were recorded. If the trigger condition was fulfilled, e.g. when the recording was started with  $P867 = 1$ , then so many values are recorded as are set at P866 (trigger delay), as in this case the "pre-event is missing".

When reading-out the values, P870 can be used to define whether the display is hexadecimal or a percentage, referred to 16384.

### 10.10.3 Output of the trace buffer contents via the analog select outputs

from SW2.00

The values of the first 4 recorded connectors can be output via select analog outputs 1 to 4 as voltages between -10V and +10V (other voltage normalizations, refer to P744, P749, P754, P759 in Section 9.2 and Section 10.1, Sheet 3).

P868 Output speed for an analog output. (300 / P868) values/s are output.

P869 Output mode

- 1 just one output (e.g. for output on a plotter)
- 2 continuous output (e.g. for output on an oscilloscope)

Assignment of the recorded value to the analog select outputs:

|                        |                |   |
|------------------------|----------------|---|
| Analog select output 1 | Terminal XA-14 | 1. Trace buffer (128 values of the connector, set at P861.01) |
| Analog select output 2 | Terminal XA-16 | 2. Trace buffer (128 values of the connector, set at P861.02) |
| Analog select output 3 | Terminal XA-18 | 3. Trace buffer (128 values of the connector, set at P861.03) |
| Analog select output 4 | Terminal XA-20 | 4. Trace buffer (128 values of the connector, set at P861.04) |

Data transfer is started similar to that described in Section 10.7.1, by setting P051 to 19, depressing the SELECT- or P key and acknowledging using the RAISE key. Analog output can be aborted at any time by depressing the LOWER key.

**Recommendation when using an oscilloscope:**

P868 = 1, P869 = 2

As a complete trace buffer output cycle, for this parameterization lasts  $128 * (1/300) = 0.427s$ , for an oscilloscope time base of 50 ms/division, the complete contents of one or several trace buffers can be displayed.

### 10.11 Speed-dependent current limiting

The speed-dependent current limiting protects the commutator and brushes of DC motors at high speeds.

The necessary settings (P104 to P107) can be taken from the motor rating plate.

Further, the maximum motor speed (P108) must be entered. This must coincide with the maximum operating speed.

The maximum operating speed is defined by:

- P143 for a speed actual value from a pulse encoder,
- P606 and P608 for speed actual values supplied from an analog tachometer,
- P115 for operation without tachometer.

Further, speed-dependent current limiting must be activated with P109 = 1!

#### NOTE

Commutator and brushes can be subject to increased wear if the speed-dependent current limiting is incorrectly set. This results in significantly reduced brush wear time!

### 10.11.1 Setting the speed-dependent current limiting for motors with commutation transition

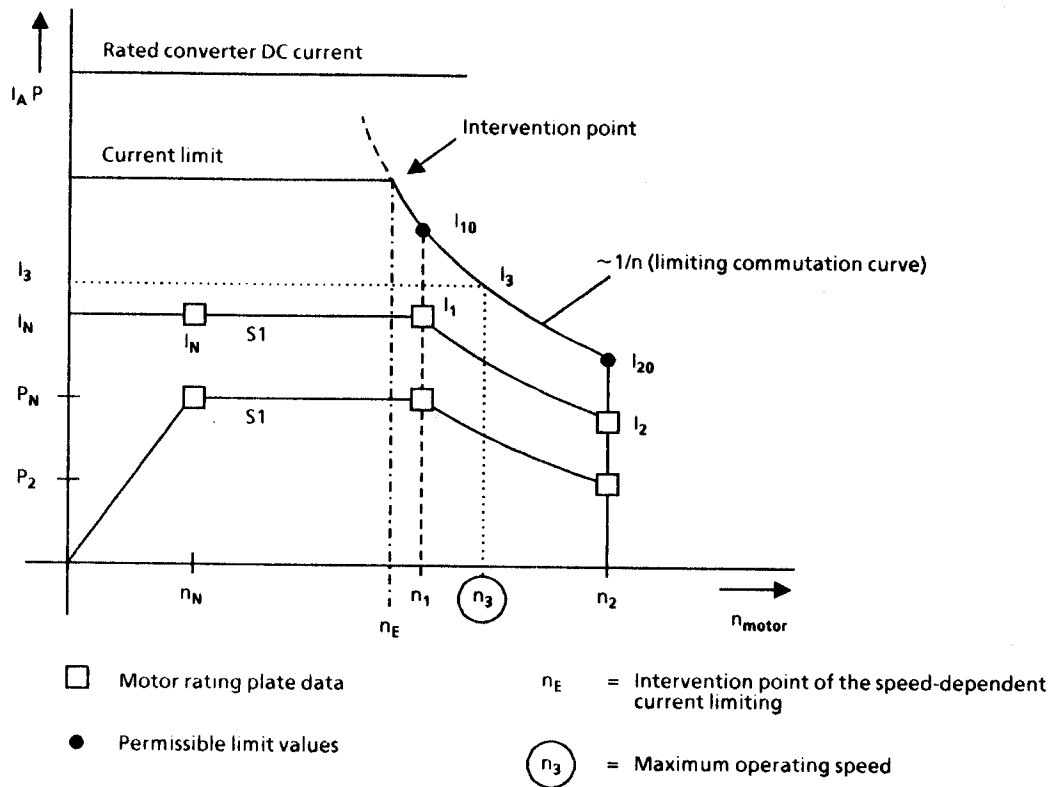

$$I_{10} = 1.4 * I_1$$

$$I_{20} = 1.2 * I_2$$

Parameter:

P104 =  $n_1$

P105 =  $I_1$

P106 =  $n_2$

P107 =  $I_2$

P108 =  $n_3$

P109 = 0 speed-dependent current limiting disabled  
 1 speed-dependent current limiting enabled

Example of a motor rating plate:

|                   |                                |                           |                |         |
|-------------------|--------------------------------|---------------------------|----------------|---------|
| * NEBENSCHL.-MOT. |                                | 1GG5162-0GG4 -6HU7        |                |         |
| IEC 160           | NR.E                           | VDE 0530                  |                |         |
| V                 | 1/MIN                          | A                         | KW             |         |
| 46-380            | 50-1490                        | 78.0-78.0                 | 0.880-26.0     |         |
| 380               | <u>3400</u> / <u>4500</u> REG. | <u>80.0</u> / <u>58.0</u> | 26.0 / 19.0    |         |
| ERR.              | V                              | THYR.: B6CLV=             | 0MH 380V/ 50HZ |         |
| FREMD             | 310                            | 2.85                      | IP23           | BAUF.   |
|                   | 77/51                          | 0.87/0.60                 |                | I.CL. F |
| Z:A11 G18 K01 K20 |                                |                           |                |         |
| FREMDKUEHLUNG     | SCHWINGSTAERKESTUFE R          |                           |                |         |

### 10.11.2 Setting the speed-dependent current limiting for motors without commutation transition

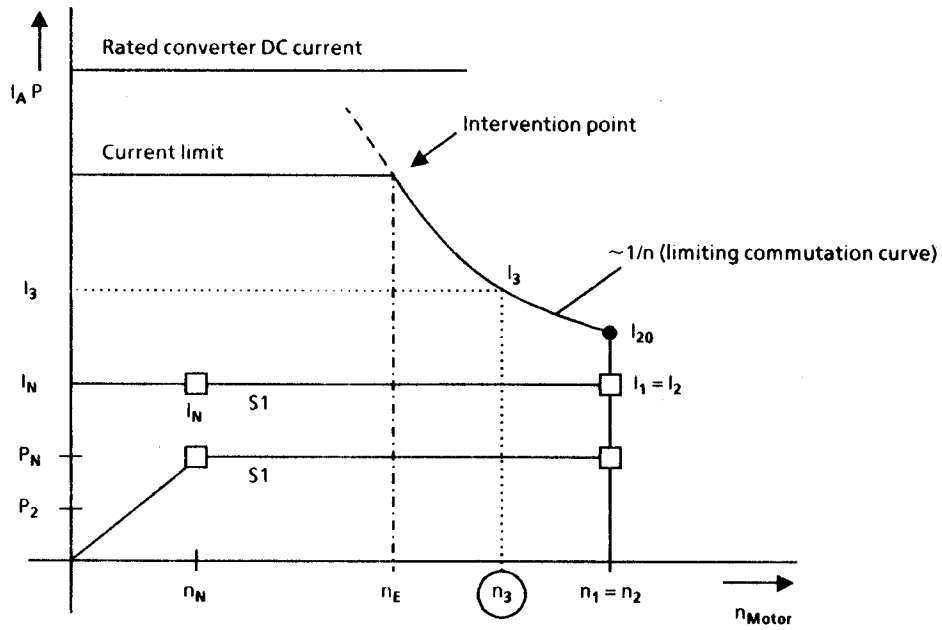

□ Motor rating plate data

● Permissible limit values

$n_E$  = Intervention point of the speed-dependent current limiting

⊙  $n_3$  = Maximum operating speed

$$I_{20} = 1.2 \cdot I_2$$

Example of a motor rating plate:

|                                      |             |          |                                |
|--------------------------------------|-------------|----------|--------------------------------|
| * NEBENSCHL.-MOT. 1GG5116-0FH4 -6HU7 |             |          |                                |
| IEC 160                              | NR.E        | VDE 0530 |                                |
| V                                    | $n_2 = n_1$ | 1/MIN    | A KW                           |
| 39-380                               |             | 50-2300  | 36.0-37.5 0.265-12.0           |
| 380                                  | 6000        | REG.     | 38.5 $I_2 = I_1$ 12.0          |
| ERR.                                 | V           | A        | THYR.: B6C LV = 0MH 380V/ 50HZ |
| FREMD                                | 310         | 1.45     | IP23 BAUF.                     |
|                                      | 54          | 0.32     | I.CL. F                        |
| Z:A11 G18 K01 K20                    |             |          |                                |
| FREMDKUEHLUNG SCHWINGSTAERKESTUFE R  |             |          |                                |



**10.12 Forcing****from SW2.00**

The "forcing" function injects a square-wave signal, which can be parameterized, for diagnostics and optimizing. The same parameters are used for setting the square-wave signal as for the binary input function "oscillation" (refer to Section 10.3.12). The setting of parameters P480 to P483 and the influence of the square-wave signals can be taken from Section 10.1, Sheet.

Procedure:

Set P051 = 24

Depress the select key (P key), to enter the parameter mode (this means that the square-wave signal (K208) is set to zero).

Briefly depress the RAISE key: "forcing" is enabled (the square-wave signal (K208) is started, and injected as new setpoint)

Briefly depress the LOWER key: "Forcing" is disabled (the operating setpoint is switched-in, and the square-wave signal (K208) is simultaneously set to 0).

By depressing the SELECT- (P-) key, i.e. when returning to the value mode, "forcing" is disabled, if this was not previously realized by depressing the LOWER key. The square-wave signal (K208) is then available and can be used for the "oscillation" function.

**10.13 Automatic re-start**

(also refer to Section 9.2, parameter P086 and Section 8.2.2 fault messages F001 to F009)

The "automatic restart" function is controlled via parameter P086:

P086 = 0                    no automatic restart

P086 = 0.1s to 2.0s      "restart time" in seconds

Using the "automatic restart" function the converter does not immediately go into the "fault" condition when the supply voltages briefly fail, brief overvoltage condition, undervoltage condition, too high or too low supply frequency or excessive deviation between the field current actual value and field current setpoint - but, once the fault condition is removed, immediately goes back to "RUN".

The appropriate fault message is only initiated, if one of the following fault conditions is present for a time which is longer than the "restart time", set at parameter P086 (maximum time until the fault condition disappears for "automatic restart"):

- F001    Failure, electronics power supply in operation (5U1, 5W1)
- F003    Undervoltage condition in a parallel SITOR set
- F004    Phase failure, armature supply (1U1, 1V1, 1W1)
- F005    Field circuit fault (phase failure, field supply (3U1, 3W1) or  
           $I_{\text{field actual}} < 50\% I_{\text{field set}}$ )
- F006    Undervoltage (armature- or field supply)
- F007    Overvoltage (armature- or field supply)
- F008    Supply frequency (armature- or field supply) less than 45Hz
- F009    Supply frequency (armature- or field supply) greater than 65Hz

If the electronics power supply fails for several 100 ms, the power supply is buffered. If the power fails for a longer period of time, the duration is measured by measuring the voltage at a "discharge capacitor", and if the failure is less than the "restart time" according to P086, the drive immediately goes into the "run" condition, assuming that the appropriate control signals (e.g. "switch-on", "operating enable") are still present.

Automatic restart is not possible when the "switch-on", "shutdown" and "crawl" functions are edge triggered (refer to P769 = 1) using the power supply buffering.

During one of the fault conditions, fault F003 to F009 is present, but the restart time has still expired, the converter waits in operating status o4.0 (for armature supply faults) or o5.0 (for field supply voltage- or field current faults).

## 11. Maintenance



### WARNING

This converter contains hazardous voltage levels.

On the customer side, hazardous voltages can be present at the signaling relays.

Death, severe bodily injury and significant material damage can occur if these converters are not handled professionally by trained personnel.

Thus, please always observe the instructions provided in this section and on the product itself when carrying out maintenance/service work on the converters.



- Service/maintenance on the converter must only be carried-out by appropriately qualified personnel who, prior to any work, must be familiar with all of the safety information provided in these instructions as well as the installation, operation and maintenance instructions.
- Before carrying-out visual checks and maintenance work, ensure that the AC power supply is disconnected and locked-out, and that the converter is grounded. Both the converter as well as the motor have hazardous voltage levels before the AC power supply is disconnected. Even though the converter contactor is open, dangerous voltage levels are still present.
- Only spare parts authorized by the manufacturer must be used.

The converter should be protected from dirt, in order to prevent voltage flashovers and thus destruction. Dust and foreign bodies, which are drawn in through the cooling air flow, should be removed at regular intervals depending on the degree of pollution, but at least every twelve months. The converter should be cleaned using dry compressed air, max. 1 bar, or with an industrial vacuum cleaner.

For converters with forced-ventilation the following should be observed:

The fan bearings are designed for a service lifetime of 30000 hours. They should be replaced in plenty of time so that the availability of the thyristor sets is maintained

## 11.1 Procedure when replacing software (upgrading to a new software release)

- 1 Read-out all parameter contents and document them.  
  
Note:  
The parameter set can be printed, or transferred to a PC or PG via the serial interfaces (also refer to Section 10.12)
- 2 Switch-off the electronics power supply
- 3 Cancel the hardware write protection. insert plug-in jumper XJ1 on the electronics board A 1600 in setting 1-2.
- 4 Replace software board A 1630 (refer to Section 5.3.1)
- 5 **Caution:** The next time the electronics power supply is switched-on, under certain circumstances all of the parameter contents will be lost!
- 6 Switch-on the electronics power supply
- 7 Acknowledge a possible fault message
- 8 Establish factory settings (default values) (refer to Section 7.4)
- 9 Start-up (refer to Section 7.5)  
Note: The parameter set stored in parameter set 1 can be loaded from a PC or PG via the serial interfaces (refer to Section 10.12)
- 10 **End**

## 12. Service



## 13. Spare parts

Please refer to Catalog DA21E for information regarding spare parts.

### **NOTE**

---

When making inquiries, always specify the following converter data:

- Converter Order No. and serial No.
- Software release
- Hardware version of the basic electronics board (printed on the component side)
- Hardware version and software release of supplementary boards (if available)





## 14. Appendix

### 14.1 Additional documentation

Circuit manual for 1Q-converters:

Order No.: C98130-A1195-A1-\*--22

Circuit manual for 4Q-converters:

Order No.: C98130-A1196-A1-\*--22

Catalog DA21

Converters

Catalog DA21E

Spare parts

Catalog DA22

Cubicle units

## Comments sheet

We have made every effort to critically edit this Instruction Manual. However, if you still come across printing errors we would be grateful if you would let us know.

We would also be grateful if you could let us have your opinion of this Instruction Manual and the converter itself.

Contact your local Siemens office for any comments - either negative or positive.

Many thanks!

SIEMENS AG Austria, Gerätewerk Vienna

---

From: Name: ..... Date: .....  
Company: .....  
Address: .....  
Tel.: .....

To: SIEMENS office  
Address: .....  
Please pass on to  
SIEMENS AG Austria  
Gerätewerk Vienna

Regarding: Comments for the 6RA24 Instruction Manual, Edition .....

## 15. SIMOVIS for 6RA24

from SW2.00



**WARNING**

Only qualified personnel, knowledgeable about these operating instructions as well as the Instruction Manual for SIMOREG converters, are allowed to start-up or commission the converter using the PC.

If the PC software is not professionally handled, the drive can run outside the specified operating points. This can result in severe bodily injury and significant material damage.

When using the control function, the drive might accidentally start.

### 15.1 What does SIMOVIS actually do

- Menu-prompted start-up
- UPREAD / DOWNLOAD parameter sets
- Prompted parameterization of analog and binary inputs and outputs as well as the motor interface
- Prompted setting for all open-loop and closed-loop control functions (technology controller, motorized potentiometer, ramp-function generator, speed controller, setpoint generation, current controller, EMF controller, field current controller, free function blocks)
- Prompted parameterization of supplementary boards
- Operating mask to input control commands and setpoints
- Trace buffer graphics: Controlling connector recording in a 6RA24 converter trace buffer, read-out and graphic display of the trace buffer contents

### 15.2 Commissioning SIMOVIS

For operation, SIMOVIS must be installed on a hard disk and the following requirements must be fulfilled:

- PC with a processor  $\geq$  80386
- MS-DOS  $\geq$  5.0
- 10 Mbyte free memory on the hard disk
- 552 Kbyte working memory (RAM) (approx. 566000 bytes)
- VGA graphics

The installation floppy disk includes a batch file which generates the required directory structure and copies all of the files required into the appropriate catalogs.

The master directory can be selected as required (e.g. C:\6RA24\ or D:\SIMOVIS\). The installation program can then be started from this catalog by specifying the floppy disk drive: Insert installation floppy disk 1 into the drive and, for the examples above, enter the following.

if the floppy disk drive is A: **C:\6RA24>A:INSTALL<RETURN>** or

if the floppy disk drive is B: **D:\SIMOVIS>B:INSTALL<RETURN>**

When the display "please insert the second floppy disk. . ." appears, insert installation floppy disk 2 in the same drive and press any key.

SIMOVIS can then be started by entering **START<RETURN>** .

The 6RA24 converter is connected to the PC with a cable as shown in Fig. 2, Section 10.7.5 (universal cable for PCIN, SIMOVIS or diagnostics monitor), or with the following configuration:

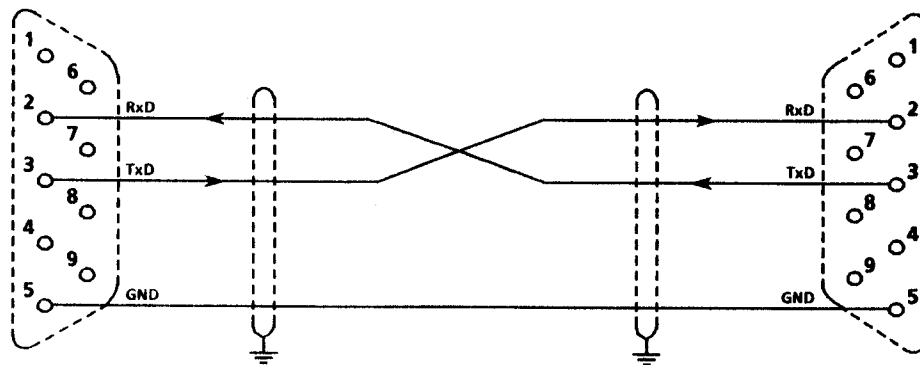

9-pin SUBMIN D connector  
at the 6RA24 converter X501: Socket connector  
on the cable: Plug connector

PC serial interface  
COM1 or COM2  
9-pin SUBMIN D plug connector  
at the PC: Plug connector  
on the cable: Socket connector

The plug-in jumpers for the RS232 interface X501 should be set as follows on the A1600 electronics board of the 6RA24 converter (this setting corresponds to the status when the equipment is shipped, refer to Section 6.8):

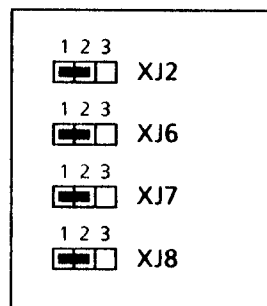

If a mouse is not found when the PC is booted, SIMOVIS provides a function, which allows the mouse pointer to be moved using the cursor keys. The following is valid:

|                     |   |                                |
|---------------------|---|--------------------------------|
| Alt - cursor right  | : | one position to the right      |
| Alt - cursor left   | : | one position to the left       |
| Alt - cursor up     | : | one position higher            |
| Alt - cursor down   | : | one position lower             |
| Ctrl - cursor right | : | several positions to the right |
| Ctrl - cursor left  | : | several positions to the left  |
| Ctrl - cursor up    | : | several positions higher       |
| Ctrl - cursor down  | : | several positions lower        |

The mouse keys are simulated from the keyboard as follows:

|                    |   |                         |
|--------------------|---|-------------------------|
| Alt - end          | : | Depress left mouse key  |
| Alt - display down | : | Release left mouse key  |
| Alt - pos1         | : | Depress right mouse key |
| Alt - display up   | : | Release right mouse key |

### 15.3 Operator control

All SIMOVIS displays have a defined display structure. The display is sub-divided into header, footer and working zones.

The **header** remains the same for all displays, and includes the following information:

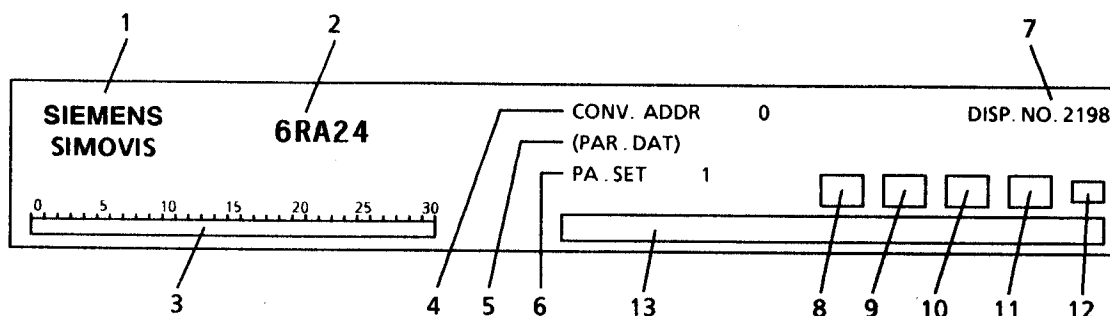

- 1 SIEMENS logo
- 2 6RA24 product logo
- 3 Bars, where the current status is displayed for all converters connected to the bus (up to 31). The following is valid:
 

|                |       |  |
|----------------|-------|--|
| Dark blue      | ..... | Converter not logged-on                                  |
| Grey, flashing | ..... | Converter logged-on but presently no connection          |
| Green          | ..... | Connection established                                   |
| Red            | ..... | Connection established, converter in the fault condition |
| Yellow         | ..... | Connection established, alarm present                    |
- 4 Converter address, which is referred to the working zone.
- 5 Name of the data file which is executed in offline operation. This line remains empty in online operation.
- 6 Number of the displayed parameter set 1 to 4 (valid for parameters in the range between P100 and P599)
- 7 Mask number
- 8 Box for displaying an existing fault (red, flashing)
- 9 Box for displaying an existing alarm (yellow, flashing)
- 10 Box for displaying a received parameter change message (yellow, flashing)
- 11 Box for displaying a communications fault (yellow, flashing)
- 12 Symbol for displaying whether a write command is presently being executed in the RAM, ("R") or is being permanently stored in the EEPROM ("E").
- 13 Window for message output.

The **footer** indicates the actually assigned function keys. The function can be executed by depressing the function key, or by clicking on the appropriate field using the mouse.

- F1 calls-up a help screen for the associated display
- F2 indicates the last 10 internal SIMOVIS messages
- F11 branches generally into the previous display
- F12 branches back to the main menu

The controller structures and parameter values are displayed in the working zone and can be modified by the user using the mouse and keyboard.

The following display elements respond to a mouse click:

- red blocks with white arrow (generally for selecting a field for entering parameter values),
- texts with a turquoise background (generally for sending a specific parameter),
- (function) blocks, with a turquoise border (generally for changing into a sub-mask),
- the footer area with the description of the function keys,
- the number after CONV.ADR in the header for entering the converter to be addressed and
- the number after PA.SET in the header for entering the parameter set to be displayed.

The following actions are possible using the keyboard:

- The display change, described in the footer, is executed using the function keys.  
The function key functions in the UPREAD/DOWNLOAD masks can only be selected via the keyboard.
- The parameter value is entered in the pop-up edit windows with the number keys and the point (as decimal point).  
The value to the left of the cursor is sent with <RETURN>.
- There are "input fields" in the mask "send process data" (2194) and "read/send any parameter" (2197), which can be cyclically selected with <TAB>, or directly by clicking the mouse, where the appropriate values can then be entered.
- For some parameters (e.g. for all those, where a connector number can be assigned), after the arrow icon is clicked, a list appears of the entry possibilities which can be selected (e.g. a list of connectors).  
Using the cursor keys, the list can be scanned in single steps, or scrolled up or down using F3/F4. If the correct entry has been found and marked, then it is sent with F8 (!) to the 6RA24 converter (<RETURN> is the same as <CURSOR BELOW>).

## Special masks

### UPREAD/DOWNLOAD mask (display No. 3999)

A mask with the existing parameter definition files appears after depressing F3 (UPREAD). By specifying a parameter number and index for each parameter, a parameter definition file is specified, which can be read from the 6RA24 converter using the UPREAD function.

The INITALL.UPR file is supplied, which includes all parameters, software release 2.00.

If only the UPREAD specific parameter is required, a definition file (after entering the new file name) can be self-generated with F5 (editing) (the parameter number in the left field and the index in the right field must be specified).

Using F4 (UPREAD), at first, the file name, under which the parameter is to be stored, is interrogated, and then UPREAD is started. The INITALL.UPR definition file includes 1404 parameters, and the actual reading takes several minutes at 19200 baud.

The parameter data file thus received has the expansion .UPD and is located in catalog SIMO\_P.

Return to the UPREAD/DOWNLOAD basic display after UPLOAD using F10 <RETURN>.

The DOWNLOAD mask is selected using F4 (DOWNLOAD). The following functions are available here:

|             |   |
|-------------|---|
| F4 DOWNLOAD | The actually selected parameter data file is transferred to the SIMOREG converter.  |
| F5 Edit     | The actually selected parameter data file is displayed as list and can be edited.   |
| F6 Copy     | Copies a parameter data file into a file with a new name.   |
| F7 Delete   | Deletes a parameter data file   |
| F8 Diff.dru | Compares two parameter data files.<br>Prints-out (parameters which differ are designated with a "**"); this function can last for more than 15 min) |
| F9 Print    | A parameter data file is printed (far faster than function F8).   |

#### Trace buffer graphics (display 2165)

In this case, an internal 6RA24 converter function is used (refer to Section 10.10), which records, over time, up to 8 connectors (with a resolution of 3.3 ms (for a 50 Hz supply frequency), and a memory depth of up to 128 values).

This "diagnostic recording" can be started on an oscilloscope. The first four connectors to be recorded can be directly defined, and the other four after printing from "F10 channel 5-8".

A connector value ">", "<", "=" of an adjustable threshold or the occurrence of an error message ("F") can be set as trigger condition.

After setting "sampling interval" (this specifies how often a recording is executed depending on the nth firing pulse cycle) and "trigger delay" (how many recordings should be executed after the trigger condition has been identified) then the recording can be activated (trigger activated).

Recording is completed as soon as "STOPPED" appears in the status window.

By clicking on the oscilloscope screen, display 3998 is selected, where the trace buffer of the 6RA24 converter can be read and transferred to the PC.

5 parameter input lines appear. The values to be sent can be entered in the righthand column, and more specifically:

|                        |   |
|------------------------|---|
| Slave No.              | Converter address of the converter where the recording is to be realized        |
| Trace channel          | 11 should be entered here   |
| Parameter number from  | 841 . . . channel 1   |
| Parameter number up to | 841 for a channel to be transferred, 842 for 2, etc. up to 848 for all channels |
| Number of entries      | 1 to 128 depending on the requirement (128 = complete trace buffer)             |

Read-out can be started when all entries have been made using F4 (READ OUT). As soon as the "number entries" in the lefthand column has returned to 0, data transfer has been completed, and the values can be graphically displayed using F3 (GRAPHIC).

A menu appears, from which one of the four representation types can be selected:

- Representation type 1:  $\pm 200\%$  \*) with interpolation between sampling values
- Representation type 2:  $\pm 200\%$  \*) without interpolation between sampling values
- Representation type 3:  $\pm 120\%$  \*) with interpolation between sampling values
- Representation type 4:  $\pm 120\%$  \*) without interpolation between sampling values

\*) The following normalization is valid,  $16384 = 100\%$

Up to four curves are shown in any one display. The display is sub-divided if more than four curves are transferred, and the curves are shown in two windows.

By clicking on the top left window "set/win", followed by "1" or "2" and "start", one of the two small displays can be blanked-out, and the other appropriately zoomed-up.

By clicking the right mouse key on "trace buffer X" in the large left window, the appropriate curve is blanked and then displayed again graphically.

The time axis normalization (according to the labeling) is one second for 128 recorded measured values. If less than 128 values are transferred, then these are displayed, right-justified, in the display window.

(The actual time normalization is obtained from the selected "sampling interval" (in cycles) 1 to: 1 second of the time-axis labeling, corresponds to  $128 * 3.333\text{ms} * \text{sampling intervals at } 50\text{Hz}$ )

#### toggling between online/offline operation

Generally, SIMOVIS operates with a permanent link to the 6RA24 converter via the serial interface.

In OFFLINE operation, actual values are not supplied from the 6RA24 converter, but from a parameter data file on the computer hard disk, which was previously generated by an UPREAD from the 6RA24 converter. Parameter value changes are written into this file. Thus, a configuration can be generated in advance, which is then simply loaded at the installation by executing a DOWNLOAD into the 6RA24 converter.

The file name of a parameter data file (.UPD) can be entered in the header in the UPREAD/DOWNLOAD mask (display 3999) in the entry field (a list of the available data files is obtained after F4 (DOWNLOAD)).

If a valid name has been entered, SIMOVIS operates offline, and the "PAR.DAT filename" is displayed in the header of each display.

Online operation can only be re-selected by depressing F7 (ONLINE) in display 3999!

#### NOTE

In the offline mode, only numerical values of parameters are displayed, however, possibly existing text descriptions are not displayed; display sections controlled from parameter values (e.g. switches) are also not displayed.

The response to parameter value changes can take some time. Entries are not possible during this time.



## 15.4 Overview of the existing masks

**Start mask (0001)**

**Main menu (2000)**

**Menu-prompted start-up (2100)**

- Check plug-in jumpers (2101)
- Adapting the rated converter DC currents (2102)
- Entering converter data (2103)
- Entering the rated motor data (2104)
- Selecting the speed actual value (2185)
  - Analog tachometer (2184)
  - Speed controller (2050)
- Pulse encoder (2183)
  - Additional parameters (2182)
  - Speed controller (2050)
- Operation without tachometer (EMF-controlled) (2180)
  - Speed controller (2050)
- Freely-connectable actual value (2179)
  - Speed controller (2050)
- Field information (2177)
- Setting basic technological functions (2176)
- Carrying-out optimization runs (2105)
- Final instructions (2106)

**Load/store parameter sets (3999)**

**Converter functions (2002)**

- Analog inputs (2150)
  - Main setpoint (2151)
  - Main actual value (2152)
    - Analog tachometer (2184)
  - Select input 1 (2153)
  - Select input 2 (2154)
  - Select input 3 (2155)
- Binary inputs (2140)
- Analog select outputs (2144)
  - Current actual value (2145)
  - Select output 1 (2146)
  - Select output 2 (2147)
  - Select output 3 (2148)
  - Select output 4 (2149)
- Binary select outputs (2142)

- Open- and closed-loop control (2005)
  - technology controller (2030)
    - Output limiting (2031)
  - Setpoint selection (ramp-function generator setpoint input) (2036)
    - Ramp-function generator setpoint input 2 (2037)
    - Motorized potentiometer (2033)
  - Ramp-function generator (2040)
    - Ramp-function generator setpoint (2038)
      - Ramp-fct. gen. setpoint input (Ramp-fct. gen. setpoint input 2) (2037)
      - Ramp-fct. gen. setpoint input 1 (2036)
    - Tension/ratio control (2039)
    - Parameter set 2 (2043)
      - Parameter set 1 (2042)
        - Parameter set 2 (2043)
        - Parameter set 3 (2044)
      - Parameter set 3 (2044)
        - Parameter set 1 (2042)
        - Parameter set 1 (2043)
    - Setpoint selection, setpoint limiting (2045)
  - Speed controller (2050)
    - Actual value conditioning (2051)
    - Adaption for speed controller, P gain Kp (2053)
    - Adaption for n controller, integral action time Tn (2054)
    - Adaption for n controller, droop (2055)
    - n/I control master/slave drive, friction- and moment of inertia compensation (2056)
      - Friction- and moment of inertia compensation K171 (2057)
      - Tabular friction characteristic (2058)
    - Additional parameters (2059)
  - Current setpoint generation (2070)
    - Speed-dependent and external current limit (2071)
    - Armature current controller setpoint M/I control changeover (2072)
    - Variable current limit (2073)
      - I<sup>2</sup>t monitoring of the power section (2074)
      - Speed-dependent current limiting (2075)
        - Motor selection with/without commutation limit (2077)
        - Motor with commutation limit (2075)
        - Motor without commutation limit (2076)
  - Current controller (2080)
    - Firing angle limiting (2081)
  - EMF controller (2085)
    - Setpoint- and actual value selection (2086)
    - Field current setpoint limiting (2087)
  - Field current controller (2090)
  - Freely-definable function blocks (2120)
    - Fixed setpoints (2121)
    - Adders 1,2,3 (2122)
    - Multiplier/divider 1 (2123)
    - Multiplier/divider 2 (2124)
    - Multiplier/divider 3 (2125)
    - Divider (2126)
    - Characteristic (display all P699) (2136)
      - Display all P698 (2137)
      - Display all P699 (2136)

- Changeover switch 1 (2128)
- Changeover switch 2 (2129)
- Changeover switch 3 (2130)
- Inverter 1,2,3 (2131)
- Absolute value generator 1,2 (2132)
- Limit value monitor 1 (2133)
- Limit value monitor 2 (2134)
- Limiter (2135)
- Parameter set administration (Page Tool) (2196)
- Serial interfaces (G-SST0 settings) (2161)
  - G-SST1 settings (2160)
    - G-SST0 settings (2161)
  - Motor interface (brush length monitoring) (2170)
    - Definition, binary monitoring (2171)
      - Brush length monitoring (2170)
      - Definition, temperature sensor (2172)
      - Motor interface, actual values (2173)
    - Definition, temperature sensor (2172)
      - Brush length monitoring (2170)
      - Definition, binary monitoring (2171)
      - Motor interface, actual values (2173)
    - Motor interface, actual values (2173)
      - Faults / alarms (2192)
  - PT10/CS51 (selecting existing supplementary boards) (2110)
    - CS51 connected (2111)
      - PZD selection SST1 (2112)
      - PZD selection SST2 (2113)
    - PT10 connected (2114)
      - PZD selection SST1 (2112)
      - PZD selection SST2 (2113)
    - CS51 und PT10 connected (2117)
      - PZD selection SST1 (2112)
      - PZD selection SST2 (2113)
- Operating masks (2195)**
  - Faults / alarms (2192)
    - Fault diagnostics (2191)
    - Operating masks (2195)
  - Motor interface, actual values (2173)
  - Send process data PZD 1 to 8 (2194)
    - Send PZD 9 to 16 (2193)
    - Send PZD 1 to 8 (2194)
  - Free parameter change (2197)
- Trace buffer graphics (2165)**
  - Read-in data (3998)
    - Display graphics (3997)

## 15.5 Troubleshooting

**Problem:** No connection was established to the SIMOREG converter.

**Remedy:** Several causes are possible:

1. The connecting cable (refer to Section 10.7.5, Fig. 2) is either faulty or incorrectly connected:  
correct COM port at the PC, refer to point 2;  
correct interface connector at the 6RA24 converter (X501 for RS232 connection).
2. The interface used (COM1, COM2, ...) is not defined in the USS..INI file in catalog SIMO\_D (operation = 0, ... for COM1, operation = 1, ... for COM2).
3. The baud rate settings in USS.INI and in the 6RA24 converter are not the same,  
operation = 0, 9600, E, 8, 1, P, 1, 1 and P793 = 6 (RS232).
4. The PZD length definition is incorrect:  
USS.INI: SLAVE = 0, 6RA24.00, 3, F, 3, 3, 8, 9, 101, 0C7E, 0000, 0000  
6RA24: P791 = 3
5. The PKW length definition is incorrect:  
USS.INI: SLAVE = 0, 6RA24.00, 3, F, 3, 3, 8, 9, 101, 0C7E, 0000, 0000  
6RA24: P792 = 3
6. The plug-in jumpers XJ2, XJ6, XJ7, XJ8 at the 6RA24 converter (on the A1600 electronics board, directly above connector X510) are not in the setting 1-2.

**Problem:** The hard disk is continuously accessed and the system is extremely slow.

**Remedy:** This can be improved by installing a harddisk cache memory (e.g. SMART DRIVE) (SIMOVIS operates with several databases on the hard disk).

The cause can also be an incorrect setting of the PZD number in USS.INI and/or P791.

**Problem:** Errors and alarms are not displayed.

**Cause:** The 6RA24 converter status word is not transferred to the SIMOVIS computer.

**Remedy:** Define the status word as the first PZD response (P794.00 = 325 or P784.00 = 325 for the RS485 interface).

**Problem:** The curve display only briefly appears when changing over to the graphic display of the trace function and then display 3998 is immediately jumped to.

**Cause:** There are no archived graphics files in the SIMO\_A catalog.

**Remedy:** Transfer the trace buffer contents in display 3998 (refer to Section 10.10).

## 16 Installation instructions for EMC-correct installation of Drives

### NOTE

These Installation Instructions do not purport to handle or take into account all of the equipment details or versions or to cover every conceivable operating situation or application. If you require more detailed information, or if special problems occur, which are not handled in enough detail in this document, please contact your local Siemens office.

The contents of these Installation Instructions are not part of an earlier or existing agreement or legal contract and neither do they change it. The actual purchase contract represents the complete liability of the ASI 1 Variable-Speed Drives Group of Siemens AG. The warranty conditions, specified in the contract between the two parties is the only warranty which will be accepted by the ASI 1 Variable-Speed Drives Group. The warranty conditions specified in the contract are neither expanded nor changed by the information provided in these Installation Instructions.

### WARNING

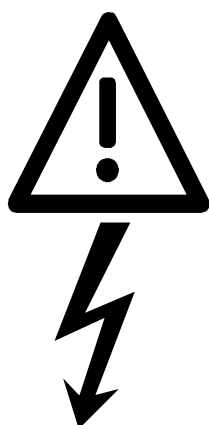

These converters have components and parts at hazardous potentials, have dangerous rotating machine components (fans) and control rotating mechanical equipment (drives). Death, severe bodily injury or significant material damage could occur if the instructions in the associated Instruction Manuals are not followed.

Only qualified personnel who are knowledgeable about all of the safety information and instructions specified in the Instruction Manual as well as installation-, operating- and maintenance information may work on these converters. Perfect and safe operation of the converters assumes that they have been professionally transported, stored, installed and mounted as well as careful operator control and maintenance.

### 16.1 EMC basics

#### 16.1.1 What is EMC

EMC stands for electromagnetic compatibility and defines the capability of a piece of equipment to operate satisfactorily in an electromagnetic environment without itself causing electromagnetic disturbances which would be unacceptable for other electrical equipment in this environment.

Thus, the electrical equipment should not mutually disturb each other.

#### 16.1.2 Noise radiation and noise immunity

EMC is dependent on two characteristics of the equipment/units involved - the radiated noise and noise immunity. Electrical equipment can either be fault sources (transmitters) and/or noise receivers. Electromagnetic compatibility exists, if the fault sources do not negatively influence the function of the noise receivers.

A piece of electrical equipment/unit can also be both a fault source and fault receiver at the same time. For example, the power section of a converter can be considered as noise source, and the control section (gating unit, etc.), as noise receiver.

### 16.1.3 Maximum values

The Product Standard E DIN IEC 22G/21/CDV is available as draft for electric drives. According to this product standard, all EMC measures are not necessarily required for industrial supply networks, and a solution should be defined, adapted to the actual environment. Thus, it may be more cost-effective to increase the noise immunity of a sensitive piece of equipment than implementing noise suppression measures for the converter. Thus, a solution is selected dependent on its cost-effectiveness.

The basic EN 50081 and EN 50082 Standards are valid until the Product Standard comes into force. These specify that EN 55011 must be maintained. These define max. values for noise radiation in industrial- and domestic environments. Cable-borne noise at the supply connection point is measured under standardized conditions as radio interference noise voltage, electromagnetically radiated noise as radio interference (radiated noise). The standard defines max. values „A1“ and „B1“, which are valid for the radio interference voltage in the range between 150kHz and 30MHz and for radio interference radiation between 30MHz and 2GHz. As SIMOREG K converters are used in industrial applications, in this case, limit value „A1“ is valid. To achieve value „A1“, SIMOREG K converters must be provided with external radio interference suppression filters.

The noise immunity defines the behavior of a piece of equipment subject to electromagnetic noise. For industrial applications, the EN50082-2 Standard defines the demands and evaluation criteria for the behavior of the unit/equipment. This standard is fulfilled by the converters listed in Section 16.2.3.

### 16.1.4 SIMOREG K converters in industrial applications

In an industrial environment, equipment must have a high level of noise immunity whereas lower demands are placed on noise radiation.

SIMOREG K converters are components of an electric drive system, along with contactors and switches etc. Professionally trained personnel must integrate them to form a complete drive system, which comprises, as a minimum, the converter itself, motor feeder cables and motor. Generally, commutating reactors and fuses are also required. Limiting (max.) values can only be maintained if these components are installed and mounted in the correct way. In order to limit the radiated noise according to limit value „A1“, in addition to the converter, a radio interference suppression filter and a commutating reactor are required. If SIMOREG K converters are not equipped with radio interference suppression filters, the radiated noise exceeds limit value „A1“, specified in EN55011.

If the drive is part of an overall system, initially it does not have to fulfill any requirements regarding radiated noise. However, the EMC Law specifies that the system as a whole must be electromagnetically compatible with its environment.

If all of the system control components (e.g. PLCs) have noise immunity for industrial environments, then it is not necessary that each drive maintains limit value „A1“ for itself.

### 16.1.5 Non-grounded supplies

Non-grounded supplies (IT-supplies) are used in several industrial sectors, in order to increase the availability of the plant. If a ground fault occurs, a fault current does not flow, and the plant can still produce. However, when a radio interference suppression filter is used, when a ground fault occurs, a fault current does flow, which can result in the drive being shutdown or even the radio interference suppression filter being destroyed. Thus, the Product Standard does not define limit values for these supplies. From a cost standpoint, if radio interference suppression is required, this should be realized at the grounded primary of the supply transformer.

### 16.1.6 EMC planning

If two units are not electromagnetically compatible, you can either reduce the noise radiated by the noise source, or increase the noise immunity of the noise receiver. Noise sources are generally power electronic units with a high current requirement. In order to reduce the radiated noise from these units, complex, costly filters are required. Noise receivers especially involve control units and sensors, including their evaluation circuitry. It is less complex and costly to increase the noise immunity of low-power equipment. Thus, in an industrial environment it is often more cost-effective to increase the noise immunity rather than reduce the radiated noise. For example, in order to maintain limit value Class A1 of EN 55011, the radio interference voltage at the supply connection point at 150kHz and 500kHz, may not exceed 79dB( $\mu$ V) and between 500kHz and 30Mhz, 73dB( $\mu$ V) (9mV or 4.5mV). In industrial environments, the EMC of the equipment used must be based on a well-balanced mixture of noise radiation (low level) and noise immunity.

The most favorably priced interference measure is to spatially isolate noise sources and noise receivers, assuming that it is already taken into account when designing the machine/plant. The first step is to define whether each unit is a potential noise source (noise radiator) or noise receiver. Noise sources are, for example, converters, contactors. Noise receivers are, for example, PLCs, transmitters and sensors.

The components must be spatially separated in the cabinet (noise sources and noise receivers), using metal partitions or by mounting the components in metal enclosures. A possible component layout configuration in a cabinet is illustrated in Fig. 1.

## 16.2 EMC-correct installation/mounting of converters (installation instructions)

### 16.2.1 General information

As drives can be operated in a wide range of differing environments, and as the electrical components used (controls, switched-mode power supplies etc.) can widely differ regarding noise immunity and noise radiation, any mounting/installation guideline can only be represent a practical compromise. Thus, deviations can be made from the EMC regulations, under the assumption that they are checked-out on a case-for-case basis.

In order to guarantee electromagnetic compatibility (EMC) in your cabinets in rugged electrical environments, and also fulfill the standards specified by the relevant legal bodies, the following EMC regulations must be observed when designing and manufacturing the drive cabinets.

Rules 1 to 10 are generally valid. Rules 11 to 15 are necessary, in order to fulfill the noise radiating standards.

### 16.2.2 Rules for EMC-correct installation

#### Rule 1

All of the metal cabinet components must be electrically connected with one another through the largest possible surface area (not paint on paint!). If required, use serrated washers. The cabinet door should be connected to the cabinet through grounding straps (top, center, bottom) which should be kept as short as possible.

#### Rule 2

Contactors, relays, solenoid valves, electro-magnetic operating hours counters etc. in the cabinet, and if required, in adjacent cabinets, should be provided with quenching elements, for example, RC elements, varistors, diodes etc. These devices must be connected directly at the coil.

**Rule 3**

Signal cables <sup>1)</sup> should enter the cabinet, if possible, at only one level.

**Rule 4**

Non-shielded cables belonging to the same circuit (incoming and outgoing conductor) should be twisted, or the surface between the two conductors kept as low as possible in order to prevent unnecessary coupling effects.

**Rule 5**

Connect reserve conductors to the cabinet ground at both ends. This offers an additional shielding effect.

**Rule 6**

Unnecessary cable/conductor lengths should be avoided. Thus, coupling capacitances and inductances are kept low.

**Rule 7**

Crosstalk is kept low if cables are routed close to the cabinet ground. Thus, wiring shouldn't be routed freely in the cabinet, but as close as possible to the cabinet frame and mounting panels. This is also true for reserve cables.

**Rule 8**

Signal- and power cables should be routed separately from one another (to avoid noise being coupled-in!). A minimum 20cm clearance should be maintained.

If it is not possible to spatially separate encoder- and motor cables, then the encoder cable must be laid either using a metal partition or in a metal pipe or duct. The partition or metal pipe must be grounded at several locations along this length.

**Rule 9**

The shields of digital signal cables must be connected to ground at both ends (source and destination) through the largest possible surface area. If there is poor potential bonding between the shield connections, to reduce the shield current, an additional potential bonding cable of at least 10mm<sup>2</sup> must be connected in parallel to the shield. The shields can be connected to the cabinet frame at several positions (ground). The shields can also be connected to ground at several locations, even outside the cabinet.

Foil-type shields should be avoided if possible. They do not shield as well as braided shields; they are poorer by a factor at least 5.

**Rule 10**

The shields of analog signal cables can be connected to ground at both ends if potential bonding is good (through the largest possible surface area). Good potential bonding can be assumed, if all metal parts are well connected and all of the electronic components involved are supplied from one source.

The single-ended shield connection prevents low-frequency, capacitive noise from being coupled-in (e.g. 50Hz hum). The shield should be connected in the cabinet, whereby the shield can also be connected up through a connecting wire.

**Rule 11**

Always locate the radio interference suppression filter close to the assumed noise source. The filter must be mounted through the largest possible surface area at the cabinet housing, mounting panel etc. The input and output cables must be spatially separated.

**Rule 12**

Radio interference suppression filters must be used in order to maintain limit value class A1. Additional loads must be connected in front of the filter (line supply side).

Ob ein zusätzliches Netzfilter installiert werden muß, ist abhängig von der verwendeten Steuerung und wie der restliche Schaltschrank verdrahtet ist.



**Rule 13**

A commutating reactor is required in the field circuit for controlled field supplies.

**Rule 14**

A commutating reactor is required in the converter armature circuit.

**Rule 15**

For SIMOREG drives, the motor cables can be unshielded. The line supply cable must be a minimum of 20cm away from the motor cables (field, armature).

If required, use a metal partition.

**Footnotes:**

1) Signal cables are defined as:

Digital signal cables.:

Pulse encoder cables

Serial interfaces, e.g. PROFIBUS-DP

or analog signal cables.:

(e.g.  $\pm 10V$  setpoint cable)

2) Generally, all metallic conductive parts, which can be connected to a protective conductor, e.g. cabinet housing, motor frame, foundation grounder, etc., are considered as ground.

**Cabinet design and shielding**

The cabinet design illustrated in **Figure 1** is intended to make the user sensitive and aware of EMC-critical components and parts. The example does not claim to handle all possible cabinet components and their respective mounting possibilities.

Details, which influence the noise immunity/noise radiation of the cabinet and which aren't absolutely clear in the overview diagram, are described in **Figures 1a - 1d**.

Different shield connecting techniques with reference source information are illustrated in detail in **Figures 2a - 2d**.

**Mounting radio interference suppression filters and commutating reactors:**

Radio interference suppression filter and commutating reactor mounting for SIMOREG K drives is described in Section 16.2.3. The sequence when installing the reactor and filter must be maintained. The semiconductor protection fuses are selected according to the Instruction Manual of the converters.

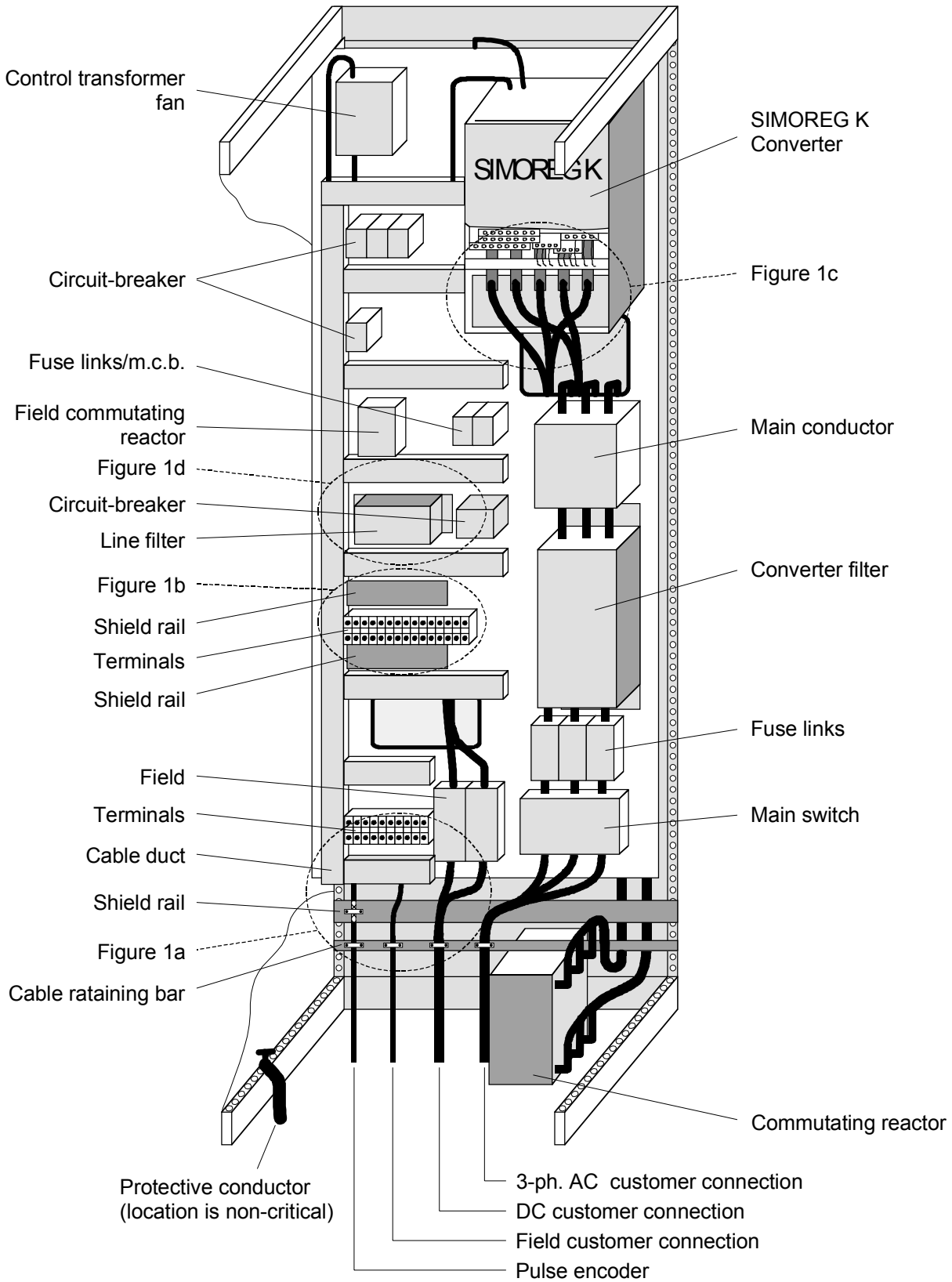

Figure 1: Example of a cabinet design with a SIMOREG K converter (with microprocessor) 30A - 600A

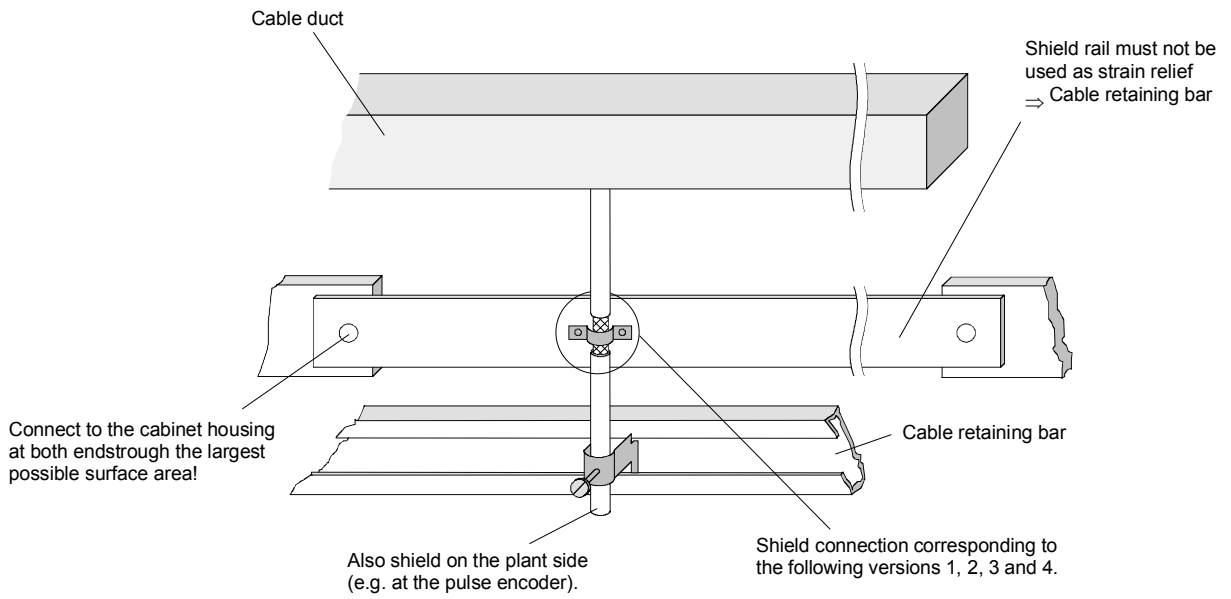

Figure 1a: Shielding where the cable enters the cabinet

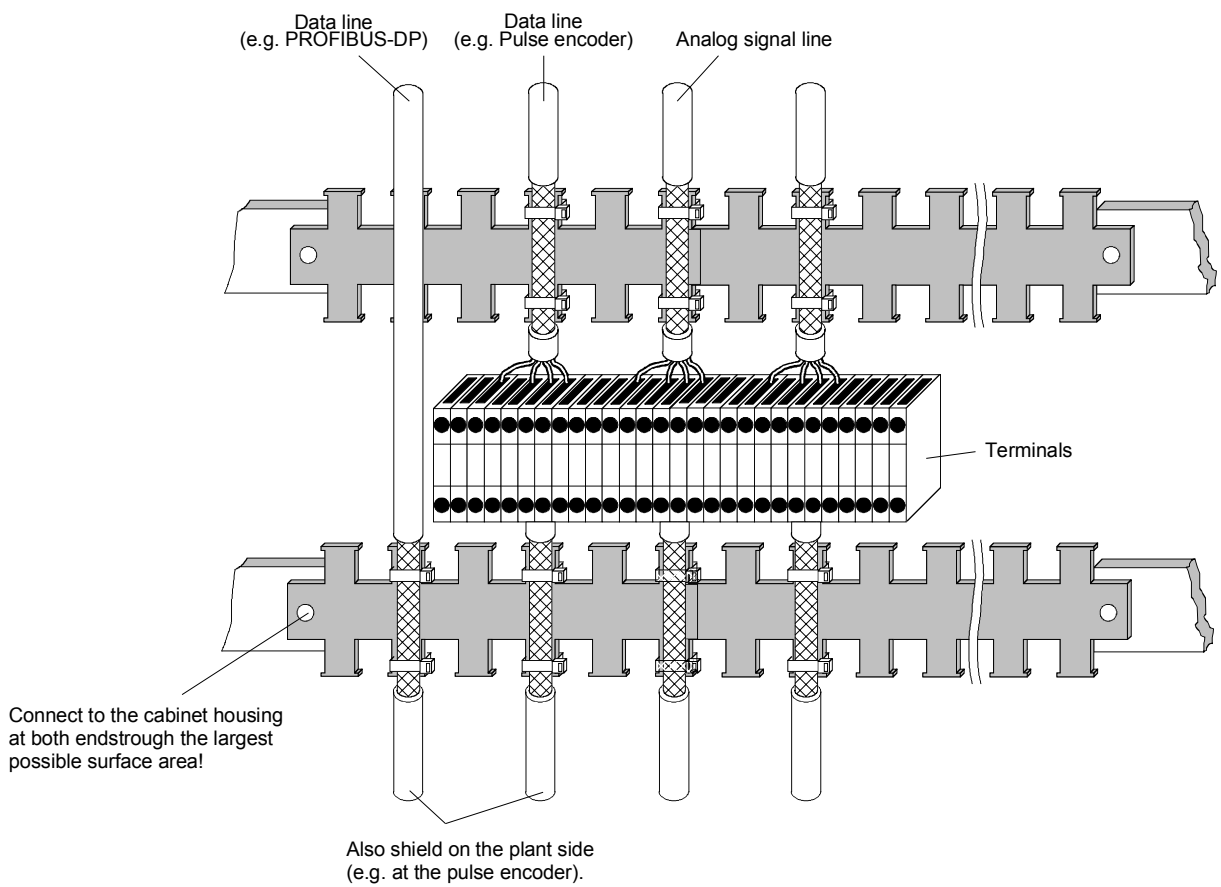

Figure 1b: Shielding in the cabinet

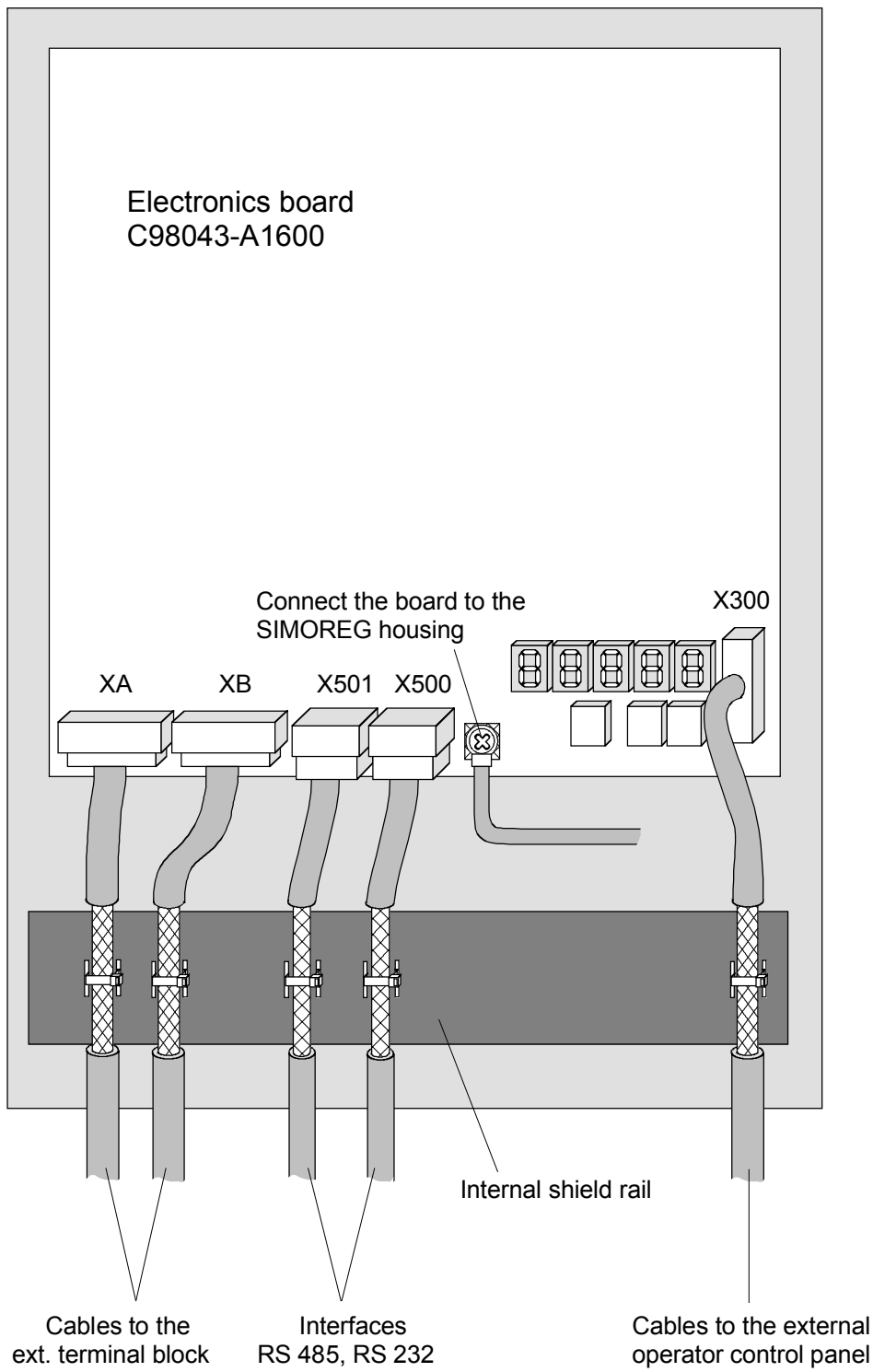

Figure 1c: Connecting the shields at the SIMOREG K 6RA24

**Connect the filter to the cabinet housing through the largest possible surface area!**

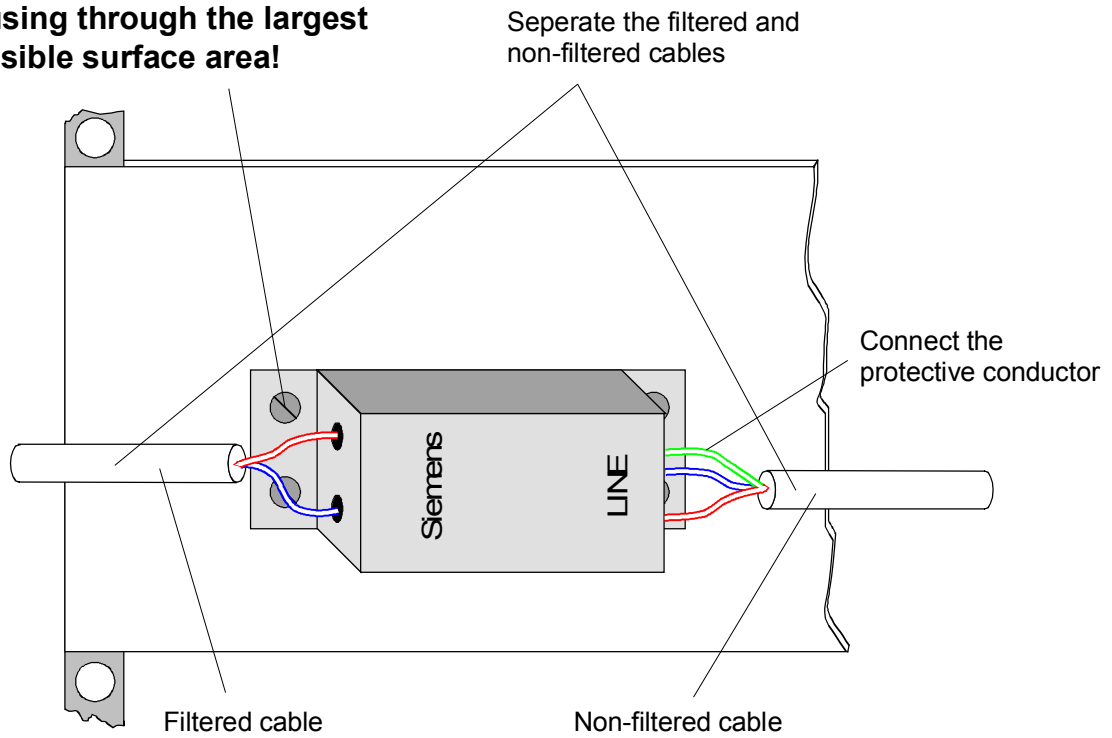

Figure 1d: Line filter for the SIMOREG K 6RA24 electronics power supply

**Shield connection:**

Version 1:

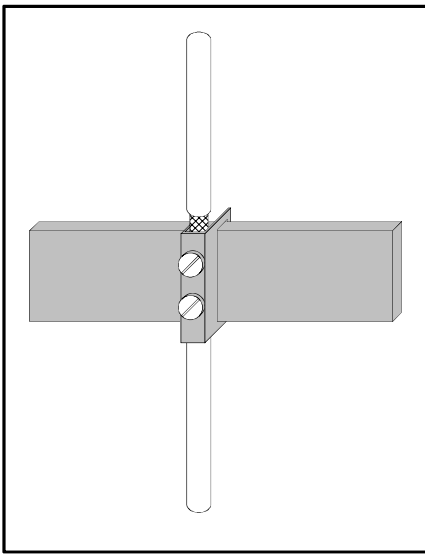

Figure 2a: Connecting terminal mounted on a copper busbar, max. cable/cable diameter 15mm

Version 2:

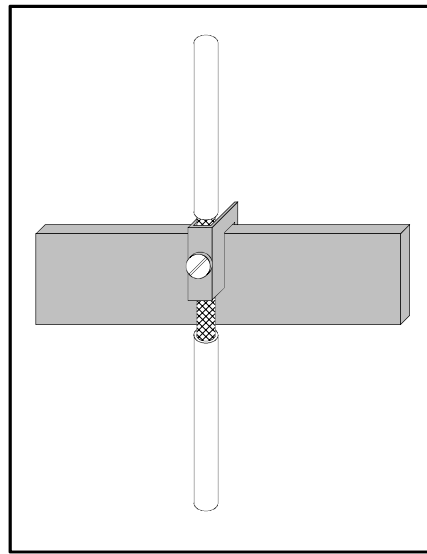

Figure 2b: Terminal mounted on a copper busbar, max. cable/cable diameter 10mm.

**Caution!**

The conductor could be damaged if the terminal screw is over-tightened

**Note:**

Terminals:  
5mm busbar thickness,  
Order No. 8US1921-2AC00  
10 mm busbar thickness,  
Order No. 8US1921-2BC00

**Note:**

Terminals:  
Order No. 8HS7104,  
8HS7104, 8HS7174, 8HS7164

Version 3:

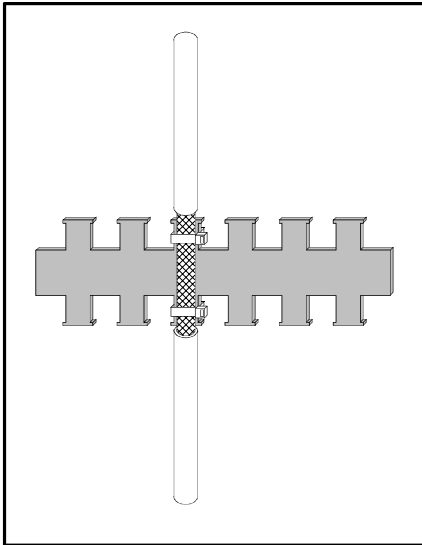

Figure 2c: Metalized tubing or cable ties on a bare metal serrated rail

Version 4:

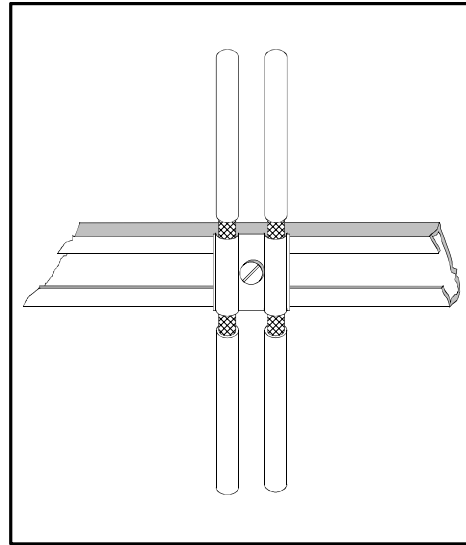

Figure 2d: Clamp and metallic mating piece on a cable support rail.

**Note:**

Serrated rail:  
Item No. J48028

**Can be ordered from:**

SIEMENS AG ANL A443 KA  
Günther-Scharowsky-Str. 2  
Betriebe Süd  
91058 Erlangen

**Note:**

Siemens 5VC55... cable clamps;  
Various size mounting rails:  
Item No. K48001 to 48005

**Can be ordered from:**

SIEMENS AG ANL A443 KA  
Günther-Scharowsky-Str. 2  
Betriebe Süd  
91058 Erlangen

### 16.2.3 Converter component arrangement

#### Reactor and filter arrangement

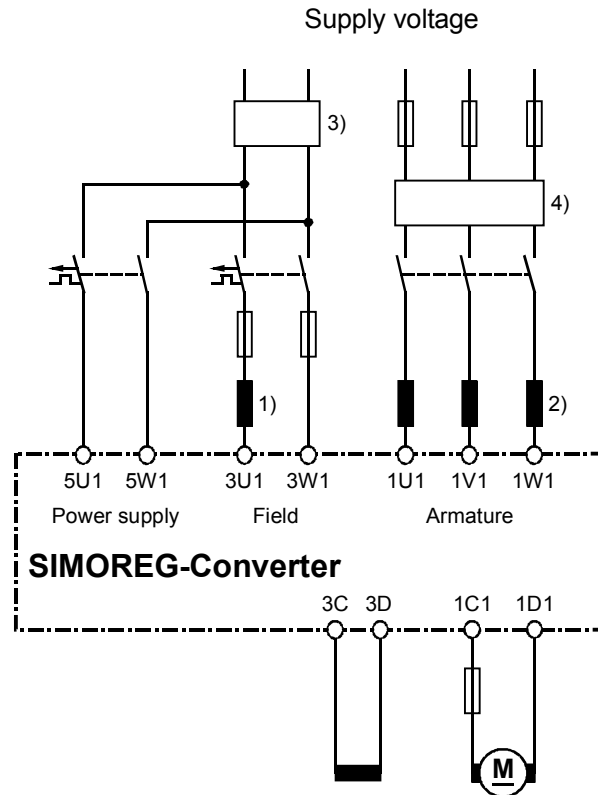

- 1) The commutating reactor in the field circuit is dimensioned for the nominal motor field current.
- 2) The commutating reactor in the armature circuit is dimensioned for the nominal motor armature current. The line supply current is the DC current x 0.82.
- 3) The field circuit filter and the electronics power supply are dimensioned for the nominal motor field current plus 0.5A.
- 4) The armature circuit filter is dimensioned for the nominal motor armature current. The line supply current is the DC current x 0.82.

#### Note:

When filters are used, commutating reactors are always required at the converter input to decouple the snubber circuitry.

The commutating reactors are selected according to the information provided in Catalog DA93.1.



#### 16.2.4 List of the recommended radio interference suppression filters

| Rated current<br>radio<br>interference<br>suppression<br>filter (A) | Radio interference<br>suppression filter<br>Order No. | Terminal<br>cross-<br>section<br>(mm <sup>2</sup> ) | Weight<br>(kg) | Dimensions<br>HxWxD<br>(mm) |
|---|---|---|----------------|-----------------------------|
| 12  | 6SE7021-0ES87-0FB0                                    | 10*)  | 2,2            | 215x90x81                   |
| 18  | 6SE7021-8ES87-0FB0                                    | 10*)  | 2,2            | 215x90x81                   |
| 36  | 6SE7023-4ES87-0FB0                                    | 25  | 3,7            | 245x101x86                  |
| 80  | 6SE7027-2ES87-0FB0                                    | 50  | 9,5            | 308x141x141                 |
| 120   | 6SE7031-0ES87-0FA0                                    | 50  | 10             | 348x171x141                 |
| 180   | 6SE7031-8ES87-0FA0                                    | 95  | 13             | 404x171x141                 |
| 500   | 6SE7033-7ES87-0FA0                                    | Connecting<br>lug                                   | 49             | 590x305x154                 |
| 1000  | 6SE7041-0ES87-0FA0                                    | Connecting<br>lug                                   | 90             | 840x465x204                 |
| 1600  | 6SE7041-6ES87-0FA0                                    | Connecting<br>lug                                   | 130            | 870x465x204                 |

\*) The filters generate discharge currents. VDE 0160 specifies a protective conductor connection with 10 mm<sup>2</sup>.

For converter units for 3-phase supplies, the line current (filter current) is equal to the DC current x 0.82.

For converters for two-phase supplies, two phases are connected to the three-phase filter. In this case, the line supply current is the same as the DC current.

#### Important technical data of the radio interference protection filter:

|                       |                                |
|-----------------------|--------------------------------|
| Rated supply voltage  | 3-ph 380-460 V (+/- 15%)       |
| Rated frequency       | 50/60 Hz (+/- 6%)              |
| Operating temperature | 0° C to +40° C                 |
| Degree of protection  | IP20 (EN60529)<br>IP00 ≥ 500 A |

Refer to the Instruction Manual for further technical data on the filters:

SIMOVERT Master Drives radio interference suppression filter, EMC filter,  
Order No.: 6SE7087-6CX87-0FB0.

**16.3 Information on line-side harmonics generated by converters in a fully-controlled three-phase bridge circuit configuration B6C and (B6)A(B6)C**

Converter for the medium power range usually consists of fully-controlled three-phase bridge circuit configurations. An example of the harmonics generated by a typical system configuration for two firing angles ( $\alpha = 20^\circ$  and  $\alpha = 60^\circ$ ) is subsequently shown.

The values have been taken from an earlier publication, and more specifically from "Harmonics in the line-side current of six-pulse line-commutated converters" from H. Arremann and G. Möltgen, Siemens Forsch.- u. Entwickl.-Ber. Bd. 7 (1978) Nr. 2, © Springer-Verlag 1978.

Formulas and equations were specified with which the short-circuit rating  $S_K$  and the armature inductance  $L_a$  could be determined dependent on the specific operating data (line supply voltage (no-load voltage  $V_{V0}$ ), line frequency  $f_N$  and DC current  $I_d$ ); this would then be valid for the specified harmonic spectrum. A dedicated calculation is required if the actual system fault level and/or the actual armature inductance deviate from the calculated values.

The specified harmonic spectrum is obtained, if the values for the system fault level  $S_K$  at the converter supply point and armature inductance  $L_a$  of the motor, calculated using the following formulas, are the same as the actual plant values. The harmonics must be separately calculated if the values differ.

a.)  $\alpha = 20^\circ$

Basic fundamental  $g = 0,962$

b.)  $\alpha = 60^\circ$

Basic fundamental  $g = 0,953$

| v  | $I_v/I_1$ | v  | $I_v/I_1$ |
|----|-----------|----|-----------|
| 5  | 0,235     | 29 | 0,018     |
| 7  | 0,100     | 31 | 0,016     |
| 11 | 0,083     | 35 | 0,011     |
| 13 | 0,056     | 37 | 0,010     |
| 17 | 0,046     | 41 | 0,006     |
| 19 | 0,035     | 43 | 0,006     |
| 23 | 0,028     | 47 | 0,003     |
| 25 | 0,024     | 49 | 0,003     |

| v  | $I_v/I_1$ | v  | $I_v/I_1$ |
|----|-----------|----|-----------|
| 5  | 0,283     | 29 | 0,026     |
| 7  | 0,050     | 31 | 0,019     |
| 11 | 0,089     | 35 | 0,020     |
| 13 | 0,038     | 37 | 0,016     |
| 17 | 0,050     | 41 | 0,016     |
| 19 | 0,029     | 43 | 0,013     |
| 23 | 0,034     | 47 | 0,013     |
| 25 | 0,023     | 49 | 0,011     |

The basic fundamental current  $I_1$  is calculated using the following formula as reference quantity

$$I_1 = g \times 0,817 \times I_d$$

with  $I_d$  DC current at the operating point being investigated

with  $g$  Harmonic content (refer above)

The harmonic currents calculated from the above tables, are **only** valid for

**I.) System fault level  $S_K$  at the converter supply connection point**

$$S_K = \frac{U_{V0}^2}{X_N} \quad (\text{VA})$$

with

$$X_N = X_K - X_D = 0,03536 \times \frac{U_{v0}}{I_d} - 2\pi f_N \times L_D \quad (\Omega)$$

and

$U_{v0}$  No-load voltage at the converter supply connection point in V

$I_d$  DC current in A at the operating point to be investigated

$f_N$  Line frequency in Hz

$L_D$  Inductance of the commutating reactor in H

## II.) Armature inductance $L_a$

$$L_a = 0,0488 \times \frac{U_{v0}}{f_N \times I_d} \quad (\text{H})$$

**A separate calculation is required if the actual system fault level  $S_K$  and/or the armature inductance  $L_a$  deviate from the values calculated using the above formula.**

### Example

A drive has the following data:

$$U_{v0} = 400 \text{ V}$$

$$I_d = 150 \text{ A}$$

$$f_N = 50 \text{ Hz}$$

$$L_D = 0,169 \text{ mH (4EU2421-7AA10 with } I_{L_N} = 125 \text{ A)}$$

With

$$X_N = 0,03536 \times \frac{400}{150} - 2\pi \times 50 \times 0,169 \times 10^{-3} = 0,0412 \quad \Omega$$

provides the following system fault level at the converter connecting point

$$S_K = \frac{400^2}{0,0412} = 3,88 \text{ MVA}$$

and the following motor armature inductance which is required.

$$L_a = 0,0488 \times \frac{400}{50 \times 150} = 2,60 \text{ mH}$$

The harmonic currents  $I_v$ , which can be taken from the tables (with  $I_1 = g \times 0.817 \times I_d$  for firing angles  $\alpha = 20^\circ$  and  $\alpha = 60^\circ$ ) are **only** valid for the calculated values  $S_K$  and  $L_a$ . A separate calculation is required if the values differ.

When dimensioning/designing filters and compensation circuits with reactors, the thus determined harmonic values can only be used if the calculated values for  $S_K$  and  $L_a$  are the same as the actual drive values. For all other case, a separate calculation must be made (this is especially true when using compensated motors, as these motors have a very low armature inductance).



SIMOVIS  
Disk 1

SIMOVIS  
Disk 2

The following versions have appeared so far:

| Version  | Internal Part number    |
|----------|-------------------------|
| 04       | C98130-A1196-A1-04-7647 |
| 05       | C98130-A1196-A1-05-7647 |
| F        | C98130-A1196-A1-06-7647 |
| <b>G</b> | C98130-A1196-A1-07-7647 |

Version **G** consists of the following chapters

| Chapter   | Pages | Date of Edition |
|---|-------|-----------------|
| 0 Contents  | 12    | 03.94           |
| 1 Safety information  | 2     | 03.94           |
| 2 Type spectrum   | 6     | 03.94           |
| 3 Description   | 10    | 03.94           |
| 4 Transport, unpacking  | 2     | 03.94           |
| 5 Installation  | 24    | 03.94           |
| 6 Connecting-up   | 42    | 03.94           |
| 7 Start-up  | 30    | 03.94           |
| 8 Operation   | 48    | 03.94           |
| 9 Parameter list  | 140   | 03.94           |
| 10 Functions  | 122   | 03.94           |
| 11 Maintenance  | 2     | 03.94           |
| 12 Service  | 2     | 03.94           |
| 13 Spare parts  | 2     | 03.94           |
| 14 Appendix   | 2     | 03.94           |
| 15 SIMOVIS  | 10    | 03.94           |
| 16 Installation instructions for EMC-correct installation of Drives | 16    | 06.96           |