

Operating Instructions · Edition 07/2008



## Control Unit

CU240E

Firmware version 3.2

# SINAMICS

## G120

**SIEMENS**



# SIEMENS

## SINAMICS

### G120 Control Units CU240E



#### Operating Instructions

<u>Introduction</u>	<b>1</b>
<u>Safety notes</u>	<b>2</b>
<u>Description</u>	<b>3</b>
<u>Installing/Mounting</u>	<b>4</b>
<u>Commissioning</u>	<b>5</b>
<u>Communication via USS</u>	<b>6</b>
<u>Operation</u>	<b>7</b>
<u>Troubleshooting</u>	<b>8</b>
<u>Service and maintenance</u>	<b>9</b>
<u>Technical data</u>	<b>10</b>
<u>Spare parts/Accessories</u>	<b>11</b>
<u>Appendix</u>	<b>A</b>
<u>List of abbreviations</u>	<b>B</b>

Edition 07/2008 Firmware version V3.2

## Safety Guidelines

This manual contains notices you have to observe in order to ensure your personal safety, as well as to prevent damage to property. The notices referring to your personal safety are highlighted in the manual by a safety alert symbol, notices referring only to property damage have no safety alert symbol. These notices shown below are graded according to the degree of danger.

 <b>DANGER</b>
indicates that death or severe personal injury <b>will</b> result if proper precautions are not taken.
 <b>WARNING</b>
indicates that death or severe personal injury <b>may</b> result if proper precautions are not taken.
 <b>CAUTION</b>
with a safety alert symbol, indicates that minor personal injury can result if proper precautions are not taken.
<b>CAUTION</b>
without a safety alert symbol, indicates that property damage can result if proper precautions are not taken.
<b>NOTICE</b>
indicates that an unintended result or situation can occur if the corresponding information is not taken into account.

If more than one degree of danger is present, the warning notice representing the highest degree of danger will be used. A notice warning of injury to persons with a safety alert symbol may also include a warning relating to property damage.

## Qualified Personnel

The device/system may only be set up and used in conjunction with this documentation. Commissioning and operation of a device/system may only be performed by **qualified personnel**. Within the context of the safety notes in this documentation qualified persons are defined as persons who are authorized to commission, ground and label devices, systems and circuits in accordance with established safety practices and standards.

## Prescribed Usage

Note the following:

 <b>WARNING</b>
This device may only be used for the applications described in the catalog or the technical description and only in connection with devices or components from other manufacturers which have been approved or recommended by Siemens. Correct, reliable operation of the product requires proper transport, storage, positioning and assembly as well as careful operation and maintenance.

## Trademarks

All names identified by ® are registered trademarks of the Siemens AG. The remaining trademarks in this publication may be trademarks whose use by third parties for their own purposes could violate the rights of the owner.

## Disclaimer of Liability

We have reviewed the contents of this publication to ensure consistency with the hardware and software described. Since variance cannot be precluded entirely, we cannot guarantee full consistency. However, the information in this publication is reviewed regularly and any necessary corrections are included in subsequent editions.

# Table of contents

<b>1</b>	<b>Introduction</b> .....	<b>7</b>
1.1	Documents for the Inverter .....	7
1.2	Description of Document Classes.....	8
<b>2</b>	<b>Safety notes</b> .....	<b>9</b>
<b>3</b>	<b>Description</b> .....	<b>13</b>
3.1	Accessories for the CU240E.....	14
3.2	Features and Functions of the CU240E .....	14
3.3	Layout and Block diagram .....	16
3.4	Interfaces of the CU240E.....	18
3.5	Factory Settings of the Control Unit.....	20
<b>4</b>	<b>Installing/Mounting</b> .....	<b>23</b>
4.1	Fitting the CU to the PM.....	23
4.2	Connecting the Control Unit via terminals .....	24
4.2.1	Frequency setpoint via terminals .....	26
4.2.2	Connecting a CU240E via USS .....	28
4.3	Installation Check List.....	28
<b>5</b>	<b>Commissioning</b> .....	<b>29</b>
5.1	Single Commissioning .....	30
5.2	Series Commissioning .....	31
5.2.1	Series Commissioning .....	31
5.2.2	Upload and Download of Parameter Sets .....	33
5.3	Common Commissioning Information.....	34
5.4	Message F00395 .....	35
5.5	Commissioning using the BOP .....	36
5.5.1	The Basic Operator Panel (BOP).....	36
5.5.1.1	Function Keys of the BOP.....	37
5.5.1.2	Changing Parameters via BOP.....	38
5.5.2	Overview Commissioning with the BOP .....	39
5.5.3	Basic Commissioning.....	40
5.5.3.1	Quick Commissioning .....	40
5.5.3.2	Calculating the Motor and Control Data.....	44
5.5.3.3	Speed Control Optimization.....	47
5.5.4	Commissioning the Application.....	48
5.5.5	Reset Parameters to Factory Settings.....	58
5.5.6	Series commissioning using the BOP.....	59
5.6	Commissioning with STARTER .....	61
5.6.1	Single Commissioning with STARTER.....	61

5.6.2	Series Commissioning with STARTER .....	62
5.7	Parameters .....	63
5.7.1	Write parameters .....	63
5.7.2	Monitoring parameters .....	64
5.7.3	Parameter Attributes .....	64
5.8	Start-up and Swap Behavior of the Inverter .....	70
5.8.1	Normal Start-up Behavior of the Inverter .....	70
5.8.2	Swap Behavior of the Inverter .....	70
<b>6</b>	<b>Communication via USS .....</b>	<b>73</b>
6.1	Universal serial interface (USS) .....	73
6.2	Structure of a USS Telegram .....	75
6.3	Use data area of USS telegram .....	77
6.4	Data Structure of the USS Parameter Channel .....	78
6.5	Timeouts and other errors .....	83
6.6	USS Process Data Channel (PZD) .....	85
<b>7</b>	<b>Operation .....</b>	<b>87</b>
7.1	ON/OFF Commands .....	87
7.2	Operation States Displayed via LED .....	90
7.2.1	LED Display .....	90
7.2.2	LED States .....	90
<b>8</b>	<b>Troubleshooting .....</b>	<b>91</b>
8.1	Faults and Alarms .....	91
8.2	Diagnostics Display .....	93
8.3	Troubleshooting with the BOP .....	93
<b>9</b>	<b>Service and maintenance .....</b>	<b>95</b>
9.1	Service and support information .....	95
<b>10</b>	<b>Technical data .....</b>	<b>97</b>
10.1	CU240E Performance ratings .....	97
<b>11</b>	<b>Spare parts/Accessories .....</b>	<b>99</b>
11.1	Basic Operation Panel .....	99
11.2	PC Connection Kit .....	99
<b>A</b>	<b>Appendix .....</b>	<b>100</b>
A.1	Electromagnetic Compatibility .....	100
A.2	Definition of the EMC Environment and Categories .....	101
A.3	EMC Overall Performance .....	102
A.4	Standards ((PM240)) .....	104
<b>B</b>	<b>List of abbreviations .....</b>	<b>105</b>
B.1	Abbreviations .....	105
	<b>Index .....</b>	<b>111</b>

# Introduction

## 1.1 Documents for the Inverter

### Available technical documentation

Comprehensive information and support tools are available from the Service and Support internet site

- <http://support.automation.siemens.com>

You find there the following types of documentation:

- Getting Started
- Operating Instructions
- Hardware Installation Manual
- Function Manual
- Parameter Manual
- Product Information

### Further internet addresses

You can download the respective documents for your inverter under the following links:

- SINAMICS G110  
<http://support.automation.siemens.com/WW/view/en/13740464/13740464>
- SINAMICS G120  
<http://support.automation.siemens.com/WW/view/en/22339653/133300>
- SINAMICS G120D  
<http://www.siemens.com/sinamics-g120d>
- SIMATIC ET 200S FC  
<http://support.automation.siemens.com/WW/view/en/18698679/133300>
- SIMATIC ET 200pro FC  
<http://support.automation.siemens.com/WW/view/en/24622073/133300>

### Application examples

You find various application examples to the inverters under the following link:

- <http://support.automation.siemens.com/WW/view/en/20208582/136000>

## 1.2 Description of Document Classes

### Description of the documents

The following section describes the available document types for your inverter:

#### Brochure

The Brochure is advertising literature designed to introduce the product to the marketplace. It contains a basic outline of the product with a brief overview of the technical capabilities of the product.

#### Catalog

The Catalog presents information that allows the customer to select an appropriate inverter including all available options. It contains detailed technical specifications, ordering and pricing information to allow the customer to order the appropriate items for their application or plant.

#### Getting Started

The Getting Started presents warnings, dimension drawings and a brief set up information for the customer.

#### Operating Instructions

The Operating Instructions gives information about the features of the inverter. It gives detailed information about commissioning, control modes, system parameters, troubleshooting, technical specifications and the available options of the product.

#### Hardware Installation Manual

The Hardware Installation Manual gives information for the Power Modules regarding the features of the product. It gives detailed information on installation, technical specifications, dimension drawings and the available options from the product.

#### Function Manual

The Function Manual is a list of detailed information about the inverter's functions. It contains descriptions of the internal components, modules and gates as well as examples for usage. Moreover associated parameters and miscellaneous logic operations of the controls are given.

#### Parameter Manual

The Parameter Manual contains a detailed description of all the parameters that can be modified to adapt the inverter to specific applications. The Parameter Manual also contains a series of function diagrams to diagrammatically portray the nature and interoperability of the system parameters.



## Safety notes

### Safety Instructions

The following Warnings, Cautions and Notes are provided for your safety and as a means of preventing damage to the product or components in the connected machines. This section lists Warnings, Cautions and Notes, which apply generally when handling the inverter, classified as General, Transport and Storage, Commissioning, Operation, Repair and Dismantling and Disposal.

Specific Warnings, Cautions and Notes that apply to particular activities are listed at the beginning of the relevant sections in this manual and are repeated or supplemented at critical points throughout these sections.

Please read the information carefully, since it is provided for your personal safety and will also help prolong the service life of your inverter and the equipment to which it is connected.

## General

 **WARNING**

This equipment contains dangerous voltages and controls potentially dangerous rotating mechanical parts. Non-compliance with the warnings or failure to follow the instructions contained in this manual can result in loss of life, severe personal injury or serious damage to property.

Protection in case of direct contact by means of SELV / PELV is only permissible in areas with equipotential bonding and in dry indoor rooms. If these conditions are not fulfilled, other protective measures against electric shock must be applied e.g. protective insulation.

Only suitably qualified personnel should work on this equipment, and only after becoming familiar with all safety notices, installation, operation and maintenance procedures contained in this manual. The successful and safe operation of this equipment is dependent upon its proper handling, installation, operation and maintenance.

As the earth leakage for this product can be greater than 3.5 mA a.c., a fixed earth connection is required and the minimum size of the protective earth conductor shall comply with the local safety regulations for high leakage current equipment.

If an RCD (also referred to as an ELCB or a RCCB) is fitted, the Power Module will operate without nuisance tripping provided that:

- A type B RCD is used.
- The trip limit of the RCD is 300 mA.
- The neutral of the supply is grounded.
- Only one Power Module is supplied from each RCD.
- The output cables are less than 15 m screened or 30 m unscreened.

The power supply, DC and motor terminals, the brake and thermistor cables can carry dangerous voltages even if the inverter is inoperative. Wait at least five minutes to allow the unit to discharge after switching off the line supply before carrying out any installation work.

It is strictly prohibited for any mains disconnection to be performed on the motor-side of the system; any disconnection of the mains must be performed on the mains-side of the Inverter.

When connecting the line supply to the Inverter, make sure that the terminal case of the motor is closed.

This equipment is capable of providing internal motor overload protection according to UL508C. Refer to P0610 and P0335, i<sup>2</sup>t is ON by default.

When changing from the ON to OFF-state of an operation if an LED or other similar display is not lit or active; this does not indicate that the unit is switched-off or powered-down.

The inverter must always be grounded.

Isolate the line supply before making or changing connections to the unit.

Ensure that the inverter is configured for the correct supply voltage. The inverter must not be connected to a higher voltage supply.

Static discharges on surfaces or interfaces that are not generally accessible (e.g. terminal or connector pins) can cause malfunctions or defects. Therefore, when working with inverters or inverter components, ESD protective measures should be observed.

Take particular notice of the general and regional installation and safety regulations regarding work on dangerous voltage installations (e.g. EN 50178) as well as the relevant regulations regarding the correct use of tools and personal protective equipment (PPE).



** CAUTION**

Children and the general public must be prevented from accessing or approaching the equipment!

This equipment may only be used for the purpose specified by the manufacturer. Unauthorized modifications and the use of spare parts and accessories that are not sold or recommended by the manufacturer of the equipment can cause fires, electric shocks and injuries.

**NOTICE**

Keep this manual within easy reach of the equipment and make it available to all users.

Whenever measuring or testing has to be performed on live equipment, the regulations of Safety Code BGV A2 must be observed, in particular § 8 "Permissible Deviations when Working on Live Parts". Suitable electronic tools should be used.

Before installing and commissioning, please read these safety instructions and warnings carefully and all the warning labels attached to the equipment. Make sure that the warning labels are kept in a legible condition and replace missing or damaged labels.

## Transport and storage

** WARNING**

Correct transport, storage as well as careful operation and maintenance are essential for the proper and safe operation of the equipment.

** CAUTION**

Protect the equipment against physical shocks and vibration during transport and storage. It is important that the equipment is protected from water (rainfall) and excessive temperatures.

## Commissioning

** WARNING**

Working on the equipment by unqualified personnel or failure to comply with warnings can result in severe personal injury or serious damage to material. Only suitably qualified personnel trained in the setup, installation, commissioning and operation of the product should carry out work on the equipment.

** CAUTION****Cable connection**

The control cables must be laid separately from the power cables. Carry out the connections as shown in the installation section in this manual, to prevent inductive and capacitive interference from affecting the correct function of the system.

## Operation

 <b>WARNING</b>
<p>The SINAMICS G120 inverters operate at high voltages.</p> <p>When operating electrical devices, it is impossible to avoid applying hazardous voltages to certain parts of the equipment.</p> <p>Emergency Stop facilities according to EN 60204, IEC 204 (VDE 0113) must remain operative in all operating modes of the control equipment. Any disengagement of the Emergency Stop facility must not lead to an uncontrolled or an undefined restart of the equipment.</p> <p>Certain parameter settings may cause the SINAMICS G120 inverter to restart automatically after an input power failure, for example, the automatic restart function.</p> <p>Wherever faults occurring in the control equipment can lead to substantial material damage or even grievous bodily injury (that is, potentially dangerous faults), additional external precautions must be taken or facilities provided to ensure or enforce safe operation, even when a fault occurs (e.g. independent limit switches, mechanical interlocks, etc.).</p> <p>Motor parameters must be accurately configured for motor overload protection to operate correctly.</p> <p>This equipment is capable of providing internal motor overload protection according to UL508C.</p> <p>Only Control Units with fail-safe functions can be used as an "Emergency Stop Mechanism" (see EN 60204, section 9.2.5.4).</p>

## Repair

 <b>WARNING</b>
<p>Repairs on equipment may only be carried out by Siemens Service, by repair centers authorized by Siemens or by authorized personnel who are thoroughly acquainted with all the warnings and operating procedures contained in this manual.</p> <p>Any defective parts or components must be replaced using parts contained in the relevant spare parts list.</p> <p>Disconnect the power supply before opening the equipment for access.</p>

## Dismantling and disposal

<b>CAUTION</b>
<p>The packaging of the inverter is re-usable. Retain the packaging for future use.</p> <p>Easy-to-release screw and snap connectors allow you to break the unit down into its component parts. You can recycle these component parts, dispose of them in accordance with local requirements or return them to the manufacturer.</p>

## Description

### The SINAMICS G120 range

The SINAMICS G120 inverter has been designed for the accurate and efficient control of the speed and torque for three-phase motors. The SINAMICS G120 system comprises two basic modules, the Control Unit (CU) and the Power Module (PM).

The Control Units are divided into the following:

- Standard CUs (CUs without fail-safe functions)
  - CU240E economic version of the CU240 control units (e.g. less terminals, no encoder interface)
  - CU240S standard version of the CU240 control units
  - CU240S DP like CU240S plus PROFIBUS DP interface (PROFIdrive Profile V4.1)
  - CU240S PN like CU240S plus PROFINET interface (PROFIdrive Profile V4.1)
- CUs with fail-safe functions
  - CU240S DP-F like CU240S DP plus integrated fail-safe functions
  - CU240S PN-F like CU240S PN plus integrated fail-safe functions

The Power Modules are divided as follows:

- PM240 Power Module with dc braking functions, supply voltage 3 AC 400 V
- PM250 Power Module with regenerative mode, supply voltage 3 AC 400 V
- PM260 Power Module with regenerative mode, supply voltage 3 AC 690 V

Control Units and Power Modules are allowed to be combined in any possible configuration. See the respective manual for specific functions and features.

This manual describes functions and features of the CU240E control units.

### 3.1 Accessories for the CU240E

The following options are available for the CU240E control units.

- BOP (Basic Operator Panel)
- PC connection kit

A description how to use the individual options or spare parts is part of the option package itself.

Ordering information and a brief functional description is given in the SINAMICS G120 catalog.

### 3.2 Features and Functions of the CU240E

#### Common features

- Modular inverter
- Simple to install
- Signal interconnection possible via BICO technology
- Different data sets selectable
- Fast current limiting (FCL) for trip-free operation
- Easy exchange of Power Module or Control Unit
- Rugged EMC design
- Configurable for a wide range of applications
- Status display via LEDs on the Control Unit
- High pulse frequencies for low noise motor operation
- EM brake relay driver

#### Features in combination with a PM240

- Built-in braking chopper for dynamic braking
- DC-link voltage controller
- Kinetic buffering

#### Features in combination with a PM250 or a PM260

- Regenerative capability
- Regenerative braking

**Commissioning functions**

- Quick commissioning
- Motor/control data calculation
- Motor data identification
- Application commissioning
- Series commissioning
- Parameter reset to the factory setting

**Operating functions**

- Adjustable setpoint channel
- Adjustable ramp-function generator (RFG)
- JOG mode
- Free function blocks (FFB)
- Fast free function blocks (Fast FFB)
- Positioning ramp down
- Automatic restart (WEA)
- Flying restart
- Current limiting
- Slip compensation
- Motor holding brake (MHB)
- Wobble generator

**Control functions**

- V/f control with different characteristics
- SLVC (Sensorless vector control mode) speed and torque

**Protective functions**

- Motor protective functions
- Inverter protective functions
- Plant/system protective functions

### 3.3 Layout and Block diagram

#### Layout characteristics of the CU240E

The figure below shows the layout and interfaces of the CU240E.

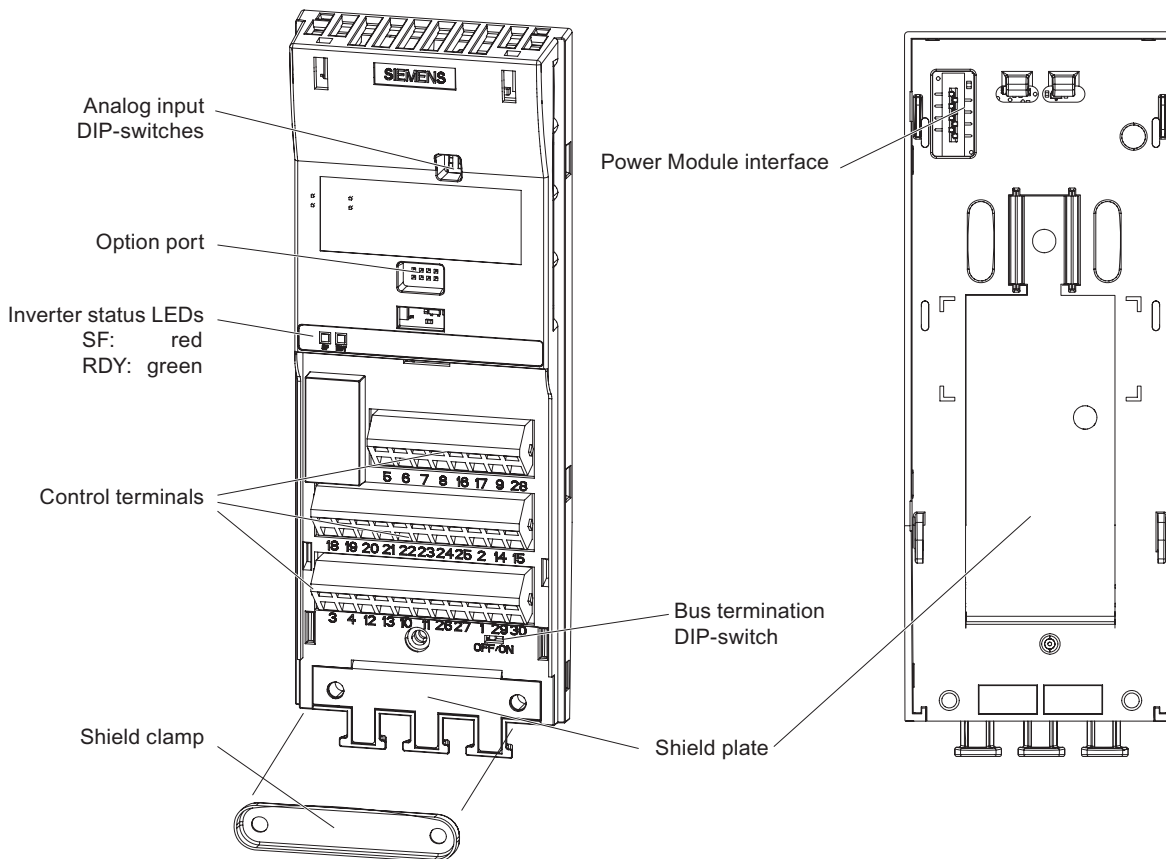

Figure 3-1 CU240E Layout



### CU240E Block Diagram

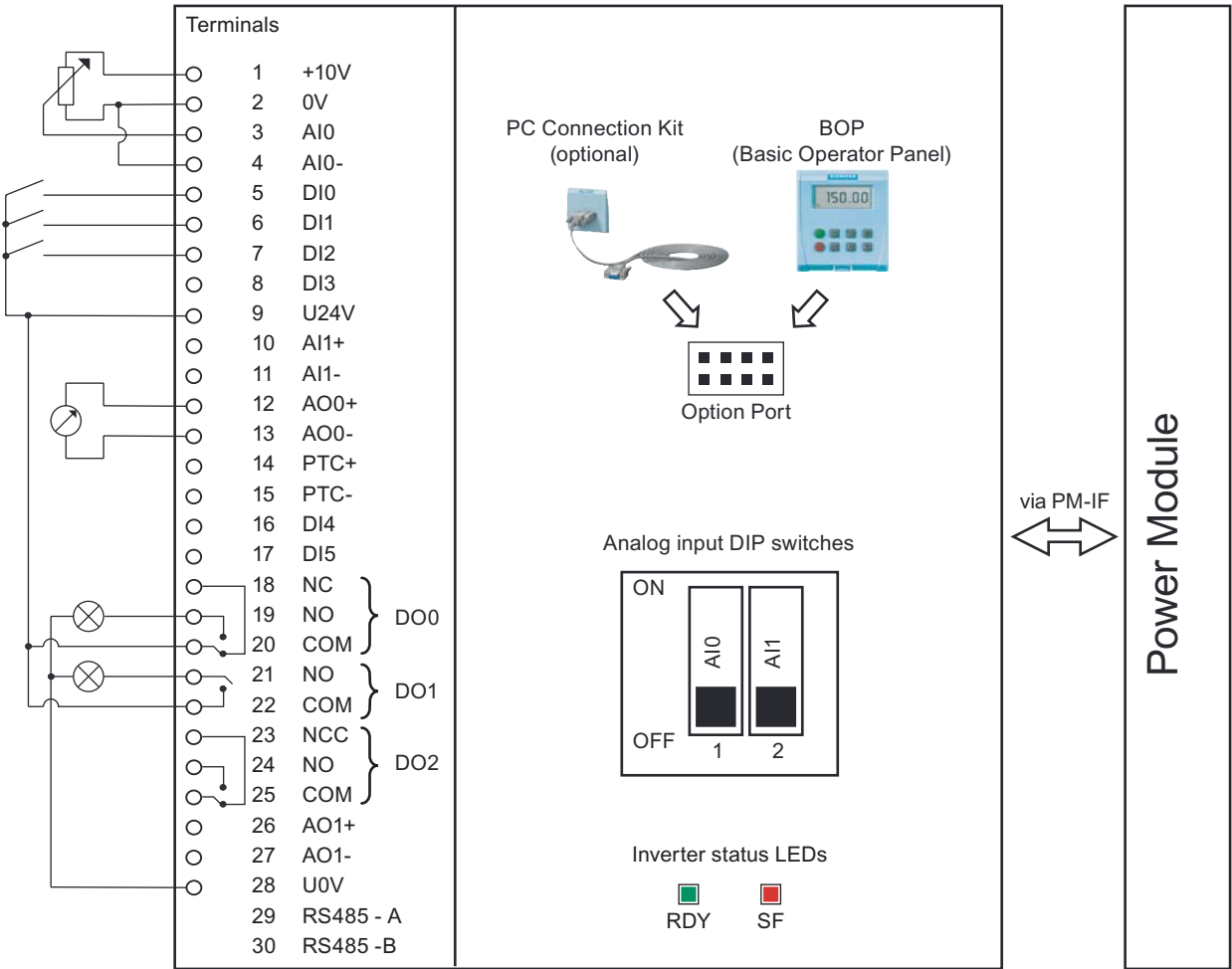

Figure 3-2 CU240E Block Diagram

## 3.4 Interfaces of the CU240E

### Overview

Table 3-1 Interfaces of the Control Unit CU240E

<b>Interface</b>	<b>Explanation</b>
Digital Inputs	6
Digital Outputs	3
Analog Inputs	2
Analog Outputs	2
PTC interface	x
10 V	x
24 V	x
Option port	Starter or BOP interface
Bus interface	USS on RS485 via terminal 29 / 30
General I/O DIP switches	x
Power module interface (PM-IF)	x
Status LEDs	2

## Terminals

Table 3-2 Control terminals

Terminal	Designation	Function
1	+10V OUT	Non-isolated output +10 V, max. 10 mA
2	0V OUT	Supply reference (terminal 1)
3	AI0+	Analog input 0 positive
4	AI0-	Analog input 0 negative
5	DI0	Digital input 0, isolated
6	DI1	Digital input 1, isolated
7	DI2	Digital input 2, isolated
8	DI3	Digital input 3, isolated
9	U24V OUT	Isolated output +24 V – max. 100 mA
10	AI1+	Analog input 1 positive
11	AI1-	Analog input 1 negative
12	AO0+	Analog output 0 positive (0/4 mA ... 20 mA, max. 500 Ω, switch via P0776 to 0/2 V ... 10 V, min. 500 Ω)
13	AO0-	Analog output 0 negative
14	PTC+	PTC Motor temperature sensor
15	PTC-	PTC Motor temperature sensor
16	DI4	Digital input 4, isolated
17	DI5	Digital input 5, isolated
18	DO0, NC	Digital output relay 0. normally closed, 0.5 A, 30 V DC
19	DO0, NO	Digital output relay 0. normally open, 0.5 A, 30 V DC
20	DO0, COM	Digital output relay 0. common, 0.5 A, 30 V DC
21	DO1, NO	Digital output relay 1. normally open, 0.5 A, 30 V DC
22	DO1, COM	Digital output relay 1. common, 0.5 A, 30 V DC
23	DO2, NC	Digital output relay 2. normally closed, 0.5 A, 30 V DC
24	DO2, NO	Digital output relay 2. normally open, 0.5 A, 30 V DC
25	DO2, COM	Digital output relay 2. common, 0.5 A, 30 V DC
26	AO1+	Analog output 1 positive (0/4 mA ... 20 mA, max. 500 Ω)
27	AO1-	Analog output 1 negative
28	U0V OUT	Supply reference (terminal 9)
29	RS485-A	RS485 Terminal A
30	RS485-B	RS485 Terminal B

The control terminals are designed as cage clamps with a nominal cross section of 1.5 mm<sup>2</sup> (AWG 14) for cable.

## Option port

Via the Option port a PC (using the PC Connection Kit) or a BOP is connected to the inverter. With a PC the inverter can be easily parameterized using the commissioning tool STARTER.

## 3.5 Factory Settings of the Control Unit

### Factory Settings for Command sources

The default setting P0700 = 0 is identical to P0700 = 2.

Table 3-3 Functions of Digital Inputs and Digital Outputs with default settings of P0700

Function	Parameter	Source
ON/OFF1	P0701 = 1	DI0
Reverse	P0702 = 12	DI1
Fault acknowledge	P0703 = 9	DI2
Fixed frequency selector bit 0	P0704 = 15	DI3
Fixed frequency selector bit 1	P0705 = 16	DI4
Fixed frequency selector bit 2	P0706 = 17	DI5
Drive fault active	P0731 = 52.3	DO0
Drive warning active	P0732 = 52.7	DO1
No function per default	P0733 = 0.0	DO2

Table 3-4 Command sources and their BICO connections with default settings of P0700

Function	Parameter	BICO command source
ON/OFF1	P0840 = 722.0	DI0
ON reverse / OFF1 (not active per default)	P0842 = 0.0	---
First OFF2 source: Coast stop	P0844 = 1	---
Second OFF2 source: Coast stop	P0845 = 19.1	BOP
First OFF3 source: Quick stop	P0848 = 1	---
Second OFF3 source: Quick stop	P0849 = 1	---
Pulse enable	P0852 = 1	---

Table 3-5 Fixed frequency command sources and their BICO connections with default settings of P0700

Function	P0700 = 2	BICO command source
Fixed frequency selection bit 0	P1020 = 722.3	DI3
Fixed frequency selection bit 1	P1021 = 722.4	DI4
Fixed frequency selection bit 2	P1022 = 722.5	DI5

Table 3-6 Monitoring settings and their BICO connections with default settings of P0700

Function	P0700 = 2	BICO command source
First source for "Fault acknowledge"	P2103 = 722.2	DI2
Second source for "Fault acknowledge" (not active per default)	P2104 = 0.0	---
External fault	P2106 = 1	---

**Factory Settings for Setpoint Source**

<b>Function</b>	<b>P1000 = 2</b>	<b>Source</b>
Frequency setpoint	r0754[0], [%]	AI0+ / AI0-



## Installing/Mounting

### Installing the Control Unit

The CU controls the functions of the PM. The CU cannot be used without a PM, also the PM cannot be used without a CU.

**! WARNING**

An inverter can be switched on unintentionally if the installation is not performed correctly. The inverter must be started-up by personnel who are qualified and trained in installing systems of this type.

### 4.1 Fitting the CU to the PM

#### Fitting the Control Unit to the Power Module

The Control Unit is snapped onto the Power Module as shown in the figure below. To disconnect the CU push the release button on top of the PM.

The process of fitting the Control Unit to the Power Module is the same technique independent from the type of G120 control unit or G120 power module.

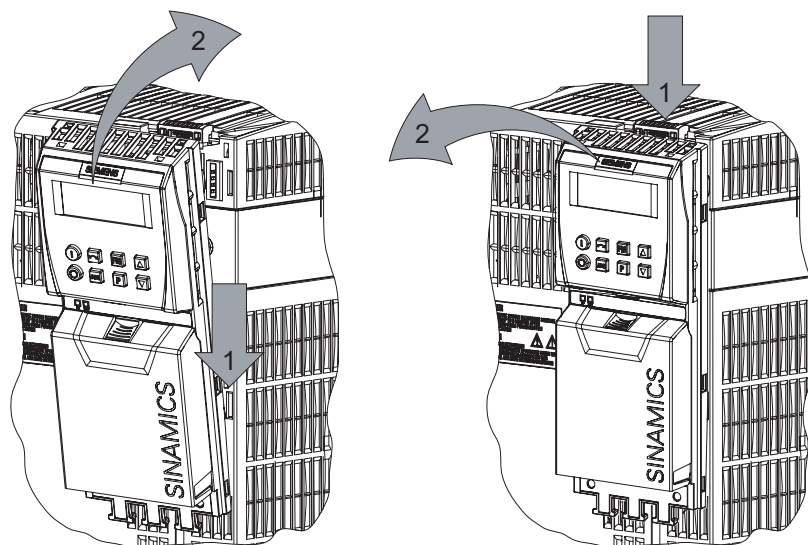

Figure 4-1 Fitting the control unit to the power module

## 4.2 Connecting the Control Unit via terminals

### Description

To have access to the control terminals, the terminal cover must be removed, as shown in the figure below. The control terminals are designed as cage clamps with a nominal cable cross section of 1.5 mm<sup>2</sup>.

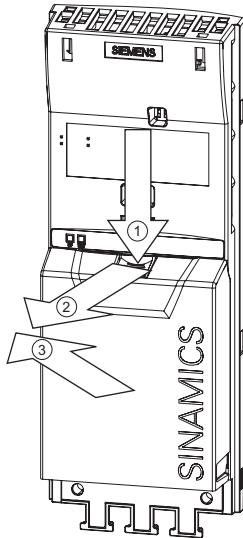

Figure 4-2 Removing the Control Unit terminal cover

After all the wiring of the control unit is completed - ensure that the terminal cover is replaced.

### Shielding the control cables

The control unit has an integrated shield plate to screen the control cables. Use a cable strap to fix each cable as shown in the figure below and fix all the cables with the fixing clamp.

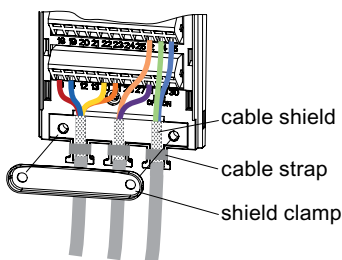

Figure 4-3 Shielding the control cables



## Terminal wiring examples for the Control Unit

In this section the following examples of controlling a SINAMICS G120 inverter with a CU240E are shown.

- Control with the default settings
- Frequency setpoint and an additional setpoint via terminals (AI0 and AI1 used as voltage inputs)
- Frequency setpoint and an additional setpoint via terminals (AI0 and AI1 used as current inputs)

 <b>CAUTION</b>
--------------------------------------------------------------------------------------------------

Use of unscreened cables is possible, however we recommend the use of screened cables in order to fulfill the EMC requirements for the CE marking.
----------------------------------------------------------------------------------------------------------------------------------------------------

## Control with the default settings

When shipped from the factory the G120 inverter (Control Unit and Power Module) must not be operated before the values depending on the specific PM are read into the CU.

This can be done via:

- Downloading a valid parameter set (by STARTER or BOP)
- Quick commissioning
- A factory reset

To operate the inverter with the basic settings (e.g. after factory reset, without additional parameterization or DIP switch setting), the following conditions have to be fulfilled:

- The rated current of the inverter is greater than or equal to the rated current of the motor.
- The power range of the inverter matches the power range of the motor.
- The controlled motor is a 4-pole motor (best Siemens 1LA7).
- The rated motor frequency is 50 Hz, power dimension unit is kW.

## Control settings

Digital and analog inputs for commands and setpoints are parameterized for cabling as shown in the block diagram of the operating instructions. Furthermore the state of the inverter is monitored via digital and analog outputs.

## See also

Layout and Block diagram (Page 16)

### 4.2.1 Frequency setpoint via terminals

#### Description

As a source for both the frequency setpoint and the additional frequency setpoint the analog input terminals can be used. Depending on the customer's needs it can be used as voltage or as current inputs. By default the AI0 and AI1 are set as voltage input terminals.

#### AI0 and AI1 used as voltage inputs

To use it as voltage inputs the following must be performed:

1. **DIP switch settings:**

Set the analog input DIP switches to OFF-position (default setting)  (DIP switch 1 refers to AI0, DIP switch 2 refers to AI1)

2. **Parameter settings**

Example, using analog input as bipolar voltage input (-10 V ... 10 V)

Parameter	Description
P0003 = 3	<b>User access level*</b> 3: Expert: For expert use only
P1000[0] = 2	<b>Selection of frequency setpoint*</b> 2: Analog setpoint (Default setting)
<b>Switch over from voltage to current input</b>	
P0756[0] = 4	<b>Type of AI0</b> (P0756[1] for AI1) Sets analog input 0 (AI0) to "bipolar voltage input (-10 V ... 10 V)"

The figure shows the control wiring to use the analog inputs as voltage inputs for both, frequency setpoint and an additional setpoint, using potentiometers on analog inputs AI0 and AI1.

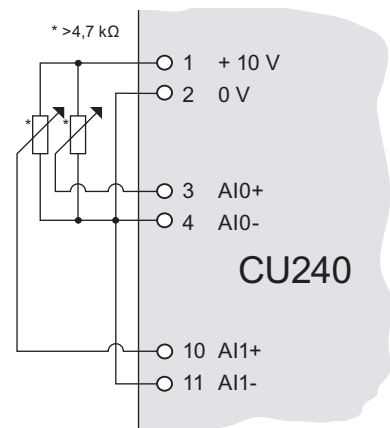

### AI0 and AI1 used as current inputs

To use it as current inputs the following must be performed:

1. **DIP switch settings:**

Set the analog input dip switches to ON-position  (DIP switch 1 refers to AI0, DIP switch 2 refers to AI1)

2. **Parameter settings**

Example, using analog input as monitored current input

Parameter	Description
P0003 = 3	<b>User access level*</b> 3: Expert: For expert use only
P1000[0] = 2	<b>Selection of frequency setpoint*</b> 2: Analog setpoint (Default setting)
<b>Switch over from voltage to current input</b>	
P0756[0] = 3	<b>Type of AI0</b> (P0756[1] for AI1) Sets analog input 0 (AI0) to "Unipolar current input with monitoring (0 to 20 mA)"
<b>Scaling the analog inputs</b>	
P0757[0] = 4	<b>Value x1 of AI0 scaling</b> (P0757[1] = for AI1) Sets analog input 0 (AI0) to a minimum of 4 mA.
P0758[0] = 0	<b>Value y1 of AI0 scaling</b> (P0758 [1] = for AI1) Sets the y scaling of the analog input at 4mA to 0 %.
P0761[0] = 4	<b>Width of AI0 dead band</b> (P0761 [1] = for AI1) Sets the dead band width of analog input 0 (AI0).

The figure shows the control wiring to use the analog inputs as current inputs for both, frequency setpoint and an additional setpoint, for example from a PLC.

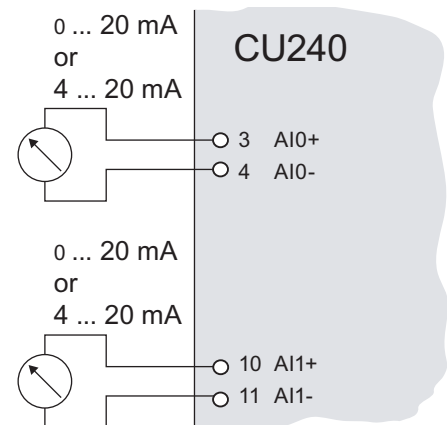

### 4.2.2 Connecting a CU240E via USS

#### Description

The CU240E can be connected via terminals 29 and 30 to an RS485-USS bus system with a maximum transfer rate of 115200 baud.

The bus termination switch is located directly beneath terminals 29 and 30.

## 4.3 Installation Check List

#### Installation check list

Before power is applied to the inverter/motor system, the following checks should be performed:

	Check that:	✓
1	The environmental conditions conform to the inverter/motor specifications	
2	The inverter and the motor are securely mounted	
3	The inverter and motor are correctly installed with adequate cooling provision	
4	The motor and the application/equipment are ready to start, i.e. safe state - motor can rotate	
5	The inverter is correctly earthed/grounded	
6	The input power (supply) voltage matches the inverter's nominal input voltage	
7	The input power (mains) fuses are the correct type and installed correctly	
8	The motor connections are connected to ensure the correct direction of rotation of the motor at start-up	
9	The motor and mains connections are connected and tightened to the required specification	
10	The motor connections are not reversed - the motor will start but serious damage may occur to the connected equipment	
11	The motor cable is routed away from other cables	
12	The control connections are connected and tightened to the required specification	
13	No tools or other objects that can cause damage to the system are present	
14	The inverter is the only power source to the motor	

# Commissioning

## Overview

A G120 inverter is composed of the Power Module and the Control Unit. After snapping the Control Unit on to the Power Module for the first time, the devices must identify each other.

To indicate, that the Power Module and the Control Unit are not yet identified, F0395 is displayed. For further information to the message F0395, refer to section "Message F00395".

The G120 inverter provides two options for commissioning:

- **Single commissioning**  
One inverter is parameterized for commissioning with an individual parameter set. Usually, use the STARTER or BOP for single commissioning.
- **Series commissioning**  
Several inverters are parameterized for commissioning via download of a complete parameter set. In case of the CU240E, use the BOP for series commissioning.

---

### Note

It is recommended to commission via STARTER. The commissioning process using STARTER is driven by dialog boxes and will not be interpreted in this manual. This manual describes the parameter related commissioning via BOP.

---

## Interfaces

The CU240E provides different communication interfaces. The following figure gives an overview:

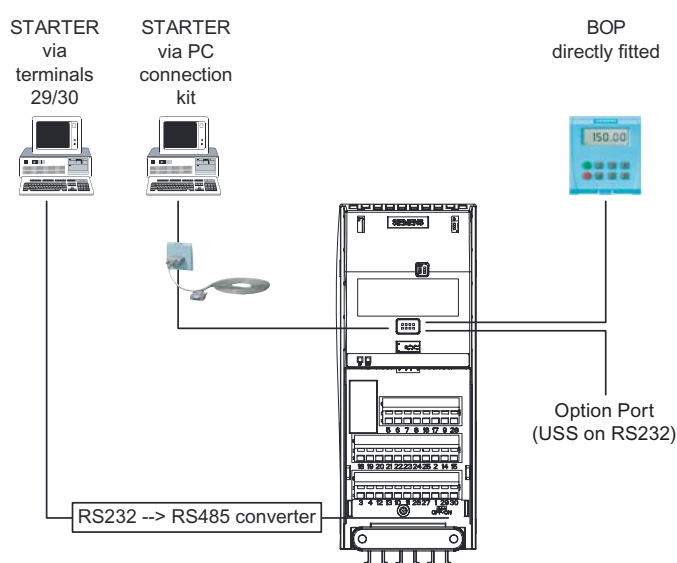

Figure 5-1 Communications Interfaces

## 5.1 Single Commissioning

### Overview

For single commissioning, set the parameter of the inverter manually. Use BOP (Basic Operator Panel) or STARTER (Commissioning software via PC) for commissioning.

---

#### Note

It is recommended to commission via STARTER. The commissioning process using STARTER is driven by dialog boxes and will not be interpreted in this manual. This manual describes the parameter related commissioning via BOP.

---

### Settings of commissioning

The following list provides an overview of commissioning settings:

- Basic commissioning
  - Quick commissioning
  - Motor data identification
  - Speed control optimization
- Further settings for commissioning
  - Calculating the motor/control data
  - Commissioning the application
  - Reset parameters to factory settings

For detailed information to the settings of single commissioning, refer to the section "Commissioning with BOP".

### Factory settings

The inverter is delivered with the following factory settings:

- Command source via terminals
- Setpoint source via terminals

---

#### Note

After the first power on, F0395 will appear. This means, the CU has not yet been commissioned. After confirming the message, you can proceed commissioning.

---

## 5.2 Series Commissioning

### 5.2.1 Series Commissioning

#### Description

Series commissioning means transferring the parameter set from one inverter into a number of other inverters. This provides fast commissioning for identical applications, e. g. series machines or group inverters.

#### Components for series commissioning

Series commissioning can be done in different ways. The following list provides an overview:

- Series commissioning with BOP
- Series commissioning with STARTER

For detailed information to series commissioning, refer to the chapters "Commissioning with BOP" and "Commissioning with STARTER".

#### Series commissioning sequence

The series commissioning is divided into the following steps:

- Creating a valid parameter set
- Uploading this parameter set
- Downloading of the uploaded parameter set into the next inverter

An appropriate parameter set can be created by parameterizing an inverter via BOP or STARTER.

 <b>CAUTION</b>
----------------------------------------------------------------------------------------------------

Parameter download between different types of Control Units and of different firmware versions is not recommended.

It is possible to download parameter sets from different Control Unit types, however, as the parameter sets might differ, the user is fully responsible for the consistency of the downloaded parameter set.

Therefore, the customer has to confirm his responsibility in case of an automatic download by acknowledging F0395.

During download of a parameter set to the EEPROM of the Control Unit (e.g. during serial commissioning) you have to note that the LEDs are flashing correctly. If the Control Unit is in a fault state, the LEDs indicate this fault state with higher priority than the download. It is not sure that the parameter set is downloaded correctly.

 **WARNING**

For series commissioning, all of the communication interfaces as well as also the digital and analog interfaces are re-initialized. This results in a brief communications failure or causes the digital outputs to switch.

Potentially hazardous loads must be carefully secured before starting a series commissioning.

Potentially hazardous loads can be secured as follows before starting series commissioning:

- Lower the load to the floor, or
- Clamp the load using the motor holding brake.

**Note**

**Upload**

Before the upload starts, the parameters will be copied from RAM to EEPROM

**Note**

**Restrictions to be considered when performing upload and download:**

- Only the parameter set stored in the EEPROM of the inverter is uploaded.
- Once the upload or download procedure has started, it should not be interrupted.
- Parameter download from a standard CUs to a CUs with fail-safe functions (e. g. CU240S DP-F) and vice versa is not possible.
- During the up or download all LEDs are flashing. After finishing that process successfully the "RDY" LED is on.
- During the upload process any data already held by the BOP is overwritten.
- If the download fails, the inverter will not function correctly and the "SF" LED (red) is on.
  - Possible fault messages in case of download failure  
F0051, F0055, F0056, F0057 or F0058

**NOTICE**

After upload and download of parameters between differing Control Units, the parameter settings must be checked.

Parameter download from a different CU might fail with F0063 if parameters cannot be downloaded (Check P949 for the (first) parameter number which cannot be downloaded).

If F0061 or F0063 occurs during startup it cannot be cleared except via a power cycle.



## 5.2.2 Upload and Download of Parameter Sets

### Upload of parameter sets

With an upload, a parameter set can be saved in one of the following devices:

- PC (via STARTER)
- BOP

An upload can be triggered via

- Communication interface
- BOP
- STARTER

### Download of parameter sets

With a download, a parameter set, saved on a PC or on the BOP, can be saved in the EEPROM of the Inverter.

It can be triggered via:

- Communication interface
- BOP
- STARTER

While the download is active the inverter status LED is flashing.

---

#### **Note**

An attempt to download a parameter set from a different CU type (e.g. CU240S) causes the fault message F00061 and the download will be aborted. F00063 can only be cleared via a power cycle.

---

## 5.3 Common Commissioning Information

### Prerequisites

Before commissioning is started, the following data must be available:

- Line supply frequency
- Motor rating plate data
- Command/setpoint sources
- Min./max. frequency or ramp-up/ramp-down time
- Control mode

An example for a rating plate is shown in the figure below. The precise definition and explanation of this data is defined in DIN EN 60034-1.

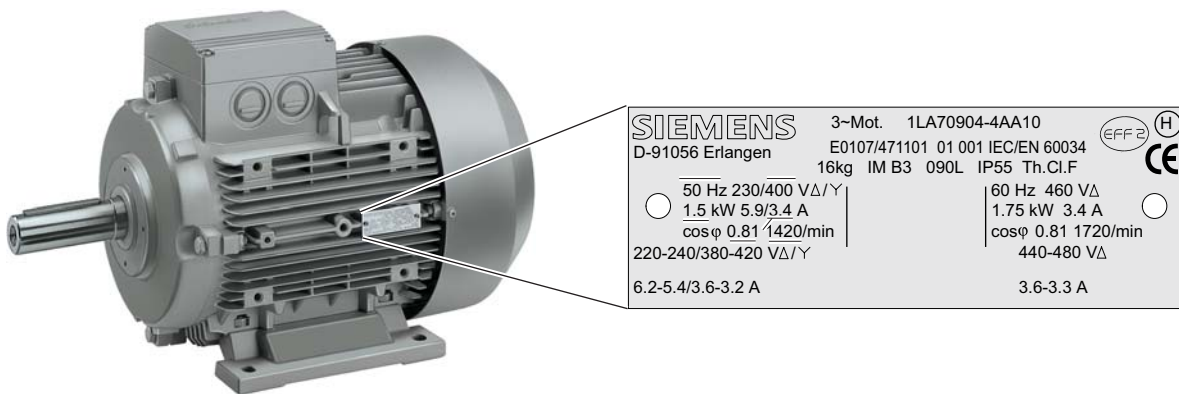

Figure 5-2 Example of a typical motor rating plate

### Note

If the inverter is to be commissioned from a defined state, it can be reset to its default settings by performing a factory reset (see section "Reset Parameters to Factory Settings")

## 5.4 Message F00395

### Description

The message F00395 is displayed to prompt you to check the parameter set or to perform a basic commissioning. By confirming F00395 you accept the responsibility for the parameter settings.

Cases which require F00395 to be confirmed:

- First power ON
- Swap of the Control Unit

---

#### **Note**

F00395 does not indicate an inverter fault.

---

### Confirming F00395

Confirm F00395 in one of the following ways:

- Pressing the **FN** function key on the BOP
- Digital input or PLC signal (depends on the settings of P0700)

---

#### **Note**

F00395 cannot be acknowledged via power cycling.

---

## 5.5 Commissioning using the BOP

### 5.5.1 The Basic Operator Panel (BOP)

The Basic Operator Panel (BOP) is used for effective parameterizing and control of the inverter. The control signals and speed reference can easily be set by pressing the appropriate buttons. The BOP has the ability to upload and download parameter sets from an inverter to another inverter.



Basic Operator Panel (BOP),  
6SL3255-0AA00-4BA1

#### Fitting the BOP to the Control Unit

The BOP is fitted to the Control Unit as shown in the figure below. No matter which type of Control Unit is being used, the process is the same.

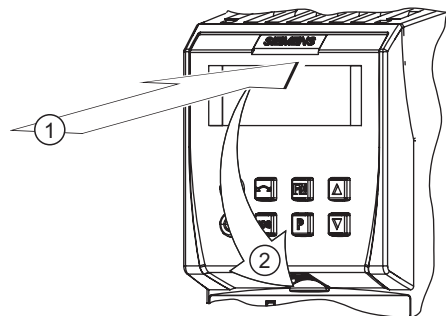









Fitting the BOP to the CU

### 5.5.1.1 Function Keys of the BOP

#### Basic Operator Panel - function keys

Table 5-1 BOP keys and their functions

Basic Operator Panel Key	Function	Effects
	Status display	The LCD indicates the settings which the drive inverter is presently using. The display reports faults and alarms.
 (Green)	Start motor	The inverter is started by pressing the key. This key is deactivated in the default setting. Parameter P0700 should be changed as follows to activate the key: BOP: P0700 = 1
 (Red)	Stop motor	OFF1   When this key is pressed, the motor comes to a standstill within the selected ramp-down time. It is deactivated in the default setting; to activate → refer to the "Start motor" key.
		OFF2   The motor coasts down to a standstill by pressing the key twice (or pressing once for a longer period of time). This function is always activated.
	Direction reversal	To reverse the direction of rotation of the motor, press this key. The opposing direction is displayed using the minus character (-) or by the flashing decimal point. In the default setting this function is deactivated. To activate it → refer to the "Start motor" key.
	Jog motor	In the "Ready to run" state, when this key is pressed, the motor starts and rotates with the pre-set jog frequency. The motor stops when the key is released. When the motor is rotating, this key has no effect.
	Function key	This key can be used to display additional information. If you press the key during operation, independent of the particular parameter, for two seconds, the following data will be displayed: 1. Voltage of the DC current link (designated by d – units V). 2. Output current (A) 3. Output frequency (Hz) 4. Output voltage (designated by o – units V). 5. The value, selected in P0005 (if P0005 is configured so that one of the above pieces of data is displayed (1 to 4), then the associated value is not re-displayed). The displays mentioned above are run-through one after the other by pressing again. <b>Step function</b> Pressing the <b>FN</b> button briefly makes the display to jump from any parameter (rXXXX or PXXXX) to r0000 and vice versa. After quitting an alarm, r0000 will be displayed and the "jumped from parameter" is forgotten. <b>Acknowledgement</b> If alarm and fault messages are present, then these can be acknowledged by pressing key <b>FN</b> .
	Parameter access	Parameters can be accessed by pressing this key.
	Increase value	When this key is pressed, the displayed value is increased.
	Reduce value	When this key is pressed, the displayed value is decreased.

### 5.5.1.2 Changing Parameters via BOP

#### Changing parameter with the BOP

The description below serves as an example that shows how to change any parameter using the BOP.

Table 5-2 Changing P0003 - parameter access level

	Step	Result on display
1	Press <b>P</b> to access parameters	r0000
2	Press <b>▲</b> until P0003 is displayed	P0003
3	Press <b>P</b> to display the parameter value	1
4	Press <b>▲</b> or <b>▼</b> to set the required value (set to 3)	3
5	Press <b>P</b> to confirm and store the value	P0003
6	All level 1 to level 3 parameters are now visible to the user.	

Table 5-3 Changing P0700 an index parameter - setting BOP control

	Step	Result on display
1	Press <b>P</b> to access parameters	r0000
2	Press <b>▲</b> until P0700 is displayed	P0700
3	Press <b>P</b> to access the parameter value	0
4	Press <b>▲</b> or <b>▼</b> to select index 1	r0001
5	Press <b>P</b> to display actual set value	0
6	Press <b>▲</b> or <b>▼</b> to the required value	1
7	Press <b>P</b> to confirm and store the value	P0700
8	Press <b>▼</b> until r0000 is displayed	r0000
9	Press <b>P</b> to return the display to the standard drive display (as defined by the customer)	

**Note**

The BOP sometimes displays "bUSY" when changing parameter values. This means that the inverter is presently handling another higher-priority task.

## 5.5.2 Overview Commissioning with the BOP

### Commissioning overview

A differentiation is made between the following scenarios when commissioning the inverter via BOP:

### Single commissioning

- Basic commissioning
  - Quick commissioning
  - Calculating the motor data,
    - automatically via Motor data identification
    - or manually via P0340
  - Speed control optimization
- Commissioning the application
- Commissioning the fail-safe functions (only in fail-safe applications)

### Series commissioning

- Uploading the parameter set
- Downloading the parameter set

### Reset parameters to factory settings

- Sets the parameter settings of the inverter settings back to the delivery state.

When commissioning, initially, a commissioning should be performed.

If there is no appropriate parameter set available for series commissioning, a single commissioning must be carried-out.

With the function "quick commissioning", the inverter is adapted to the motor and important technological parameters are set.

The step "commissioning the application" should only be performed, if the inverter-motor combination provides a satisfactory result.

### 5.5.3 Basic Commissioning

#### 5.5.3.1 Quick Commissioning

##### V/f mode

For applications using V/f (P1300 = 0 [default]) or Flux Current Control (FCC) (P1300 = 1 or 6), quick commissioning can be accomplished by setting the following parameters:

Table 5-4 Quick commissioning - V/f mode

Parameter	Description	Setting
P0003 = 3	<b>User access level*</b> 1: Standard: Allows access into most frequently used parameters (default) 2: Extended: Allows extended access e.g. to inverter I/O functions 3: Expert: For expert use only	
P0004 = 0	<b>Parameter filter*</b> 0: All parameters (default) 2: Inverter 3: Motor 4: Speed sensor	
P0010 = 1	<b>Commissioning parameter filter*</b> 0: Ready (default) 1: Quick commissioning 30: Factory setting Note: P0010 should be set to 1 in order to parameterize the data of the motor rating plate.	
P0100 = 0	<b>Europe/North America</b> (enter the motor frequency) 0: Europe [kW], frequency default, 50 Hz (default) 1: North America [hp], frequency default, 60 Hz 2: North America [kW], frequency default, 60 Hz	
P0304 = ...	<b>Rated motor voltage</b> (enter value from the motor rating plate in volts) The input of rating plate data must correspond with the wiring of the motor (star/delta). This means, if delta wiring is used for the motor, delta rating plate data has to be entered.	
P0305 = ...	<b>Rated motor current</b> enter value from the motor rating plate in ampere	
P0307 = ...	<b>Rated motor power</b> enter value from the motor rating plate in kW or hp Note: if P0100 = 0 or 2, data is in kW and if P0100 = 1, data is in hp.	
P0310 = ...	<b>Rated motor frequency</b> enter value from the motor rating plate in Hz Pole pair number recalculated automatically if parameter is changed.	
P0311 = ...	<b>Rated motor speed</b> enter value from the motor rating plate in RPM) Setting P0311 = 0 causes internal calculation of value (required for vector control). Slip compensation in V/f control requires rated motor speed for correct operation.	
P0700 = 2	<b>Selection of command source*</b> 0: Factory default setting 1: BOP (keypad) <b>2: Terminal</b> 5: USS on RS485	



Parameter	Description	Setting
P1000 = 2	<b>Selection of frequency setpoint*</b> 0: No main setpoint 1: MOP setpoint <b>2: Analog setpoint</b> 3: Fixed frequency 5: USS on RS485 7: Analog setpoint 2	
P1080 = ...	<b>Minimum frequency</b> Enter the lowest motor frequency (in Hz) to which the motor operates independently of the frequency setpoint. The value set here is valid for both clockwise and anticlockwise rotation.	
P1082 = ...	<b>Maximum frequency</b> Enter the maximum frequency (in Hz) to which the motor is limited independently of the frequency setpoint. The value set here is valid for both clockwise and anticlockwise rotation.	
P1120 = ...	<b>Ramp-up time</b> Enter the time (in seconds) in which the motor should accelerate from standstill up to maximum motor frequency P1082. If the ramp-up time is set too short, this can cause alarm A0501 (current limit value) or tripping the inverter with fault F0001(overcurrent).	
P1121 = ...	<b>Ramp-down time</b> Enter the time (in seconds) in which the motor should decelerate (using braking) from the maximum frequency P1082 down to standstill. If the ramp-down time is set too short, this can cause alarm A0501 (current limit value) or A0502 (overvoltage limit value) or tripping the inverter with fault F0001 (overcurrent) or F0002 (overvoltage).	
P1300 = ...	<b>Control mode*</b> 0: V/f with linear characteristic (default) 1: V/f with FCC 2: V/f with parabolic characteristic 3: V/f with programmable characteristic	
P3900 = ...	<b>End quick commissioning (QC)*</b> 0: No quick commissioning (no motor calculations, default) 1: Motor calculation and reset of all parameters that haven't been changed while QC process to factory setting. 2: Motor calculation and reset of all I/O settings to factory settings. 3: Only motor calculation - other parameters are not reset. Note: If P3900 = 1, 2, or 3 P0340 is set to 1 and the value from P1082 is written into P2000. The appropriate motor data will be calculated.  While end of quick commissioning is performed <b>"bUSY"</b> will be displayed on the BOP. This means that the control data are being calculated and the respective parameter values are stored in the EEPROM. After quick commissioning has been completed, P3900 and P0010 will be set to 0. The actual frequency is displayed.	

**Vector Control mode**

For applications using Vector Control (P1300 = 20 ... 22), quick commissioning should be performed as described in the following table:

Parameters designated with an "\*" offer more settings than are actually shown here. Refer to the Parameter list for additional settings.

Table 5-5 Quick commissioning - Vector Control mode

Parameter	Description	Setting
P0003 = 3	<b>User access level*</b> 1: Standard: Allows access into most frequently used parameters (default) 2: Extended: Allows extended access e.g. to inverter I/O functions 3: Expert: For expert use only	
P0004 = 0	<b>Parameter filter*</b> 0: All parameters (default) 2: Inverter 3: Motor 4: Speed sensor	
P0010 = 1	<b>Commissioning parameter filter*</b> 0: Ready (default) 1: Quick commissioning 30: Factory setting Note: P0010 should be set to 1 in order to parameterize the data of the motor rating plate.	
P0100 = 0	<b>Europe/North America</b> (enter the motor frequency) 0: Europe [kW], frequency default, 50 Hz (default) 1: North America [hp]. frequency default, 60 Hz 2: North America [kW], frequency default, 60 Hz	
P0304 = ...	<b>Rated motor voltage</b> (enter value from the motor rating plate in volts) The input of rating plate data must correspond with the wiring of the motor (star/delta). This means, if delta wiring is used for the motor, delta rating plate data has to be entered.	
P0305 = ...	<b>Rated motor current</b> enter value from the motor rating plate in ampere	
P0307 = ...	<b>Rated motor power</b> enter value from the motor rating plate in kW or hp Note: if P0100 = 0 or 2, data is in kW and if P0100 = 1, data is in hp.	
P0310 = ...	<b>Rated motor frequency</b> enter value from the motor rating plate in Hz Pole pair number recalculated automatically if parameter is changed.	
P0311 = ...	<b>Rated motor speed</b> enter value from the motor rating plate in RPM) Setting P0311 = 0 causes internal calculation of value (required for vector control). Slip compensation in V/f control requires rated motor speed for correct operation.	
P0700 = 2	<b>Selection of command source*</b> 0: Factory default setting 1: BOP (keypad) <b>2: Terminal</b> 5: USS on RS485	

Parameter	Description	Setting
P1000 = 2	<b>Selection of frequency setpoint*</b> 0: No main setpoint 1: MOP setpoint <b>2: Analog setpoint</b> 3: Fixed frequency 5: USS on RS485 7: Analog setpoint 2	
P1080 = ...	<b>Minimum frequency</b> Enter the lowest motor frequency (in Hz) to which the motor operates independently of the frequency setpoint. The value set here is valid for both clockwise and anticlockwise rotation.	
P1082 = ...	<b>Maximum frequency</b> Enter the maximum frequency (in Hz) to which the motor is limited independently of the frequency setpoint. The value set here is valid for both clockwise and anticlockwise rotation.	
P1120 = ...	<b>Ramp-up time</b> Enter the time (in seconds) in which the motor should accelerate from standstill up to maximum motor frequency P1082. If the ramp-up time is set too short, this can cause alarm A0501 (current limit value) or tripping the inverter with fault F0001 (overcurrent).	
P1121 = ...	<b>Ramp-down time</b> Enter the time (in seconds) in which the motor should decelerate (using braking) from the maximum frequency P1082 down to standstill. If the ramp-down time is set too short, this can cause alarm A0501 (current limit value) or A0502 (overvoltage limit value) or tripping the inverter with fault F0001 (overcurrent) or F0002 (overvoltage).	
P1300 = ...	<b>Control mode*</b> 20: Sensorless vector control 21: Vector control with sensor 22: Sensorless vector torque-control	
P3900 = ...	<b>End quick commissioning (QC)*</b> 0: No quick commissioning (no motor calculations, default) 1: Motor calculation and reset of all parameters that haven't been changed while QC process to factory setting. 2: Motor calculation and reset of all I/O settings to factory settings. 3: Only motor calculation - other parameters are not reset. Note: If P3900 = 1, 2, or 3 P0340 is set to 1 and the value from P1082 is written into P2000. The appropriate motor data will be calculated.  While end of quick commissioning is performed <b>"bUSY"</b> will be displayed on the BOP. This means that the control data are being calculated and the respective parameter values are stored in the EEPROM. After quick commissioning has been completed, P3900 and P0010 will be set to 0. The actual frequency is displayed.	

<b>NOTICE</b>
---------------

P700 and P1000 are evaluated by the communication timeout function. Only the communication interfaces set in P700 and P1000 is monitored (USS P2014).
-------------------------------------------------------------------------------------------------------------------------------------------------------

**Next to "Quick Commissioning"**

Next to "Quick Commissioning" the motor data should be calculated. This can be done automatically via "Motor Data Identification" or manually via setting the parameters P0340 ... P0360.

Additionally in case of vector mode (P1300 = 20/21) the "Speed Control Optimization" should be performed.

**Note**

"Motor Data Identification" and "Speed Control Optimization" need an ON command to start.

**5.5.3.2 Calculating the Motor and Control Data**

**Automatic Calculation via Motor Data Identification**

 <b>WARNING</b>
<p>The motor data identification routine <b>MUST</b> not be used for loads which are potentially hazardous (for example, suspended loads for crane applications). Before the motor data identification routine is started, the potentially hazardous load must be carefully secured (for example, by lowering the load to the floor or by clamping the load using the motor holding brake).</p>

Parameter	Description
P0625 = ...	<p><b>Ambient motor temperature</b> (entered in °C)                      The motor ambient temperature is entered at the instant that motor data is being determined (factory setting: 20 °C).                      The difference between the motor temperature and the motor ambient temperature P0625 must lie in the tolerance range of approx. ± 5 °C.</p>
If not the motor must be allowed to cool down.	
P0010 = 0	<p><b>Commissioning parameter filter*</b>                      Check if P0010 = 0 (Ready)</p>
P1900 = 3	<p><b>Select motor data identification*</b>                      0: Disabled (default)                      2: Identification of all parameters in standstill.                      3: Identification of all parameters in standstill including saturation curve</p>
ON command	<p><b>Start motor data identification</b>                      Once P1900 ≠ 0, alarm A0541 is generated that states, the next ON command will initiate the motor data identification. When the ON Command is given, current flows through the motor and the rotor aligns itself.                      Note: When motor data identification is complete A0541 will be cleared and P1900 will be set to zero.</p>
OFF1	<p>In order to set the inverter into a defined state, an OFF1 command must be issued before the next step. With the OFF1 command the motor data identification is finished.</p>

### Manually Calculating the Motor and Control Data

The internal motor/control data are calculated using parameter P0340 or, indirectly using parameter P3900 or P1910. The functionality of parameter P0340 can, for example, be used if the equivalent circuit diagram data or the moment of inertia values are known. The following settings are possible for P0340:

- 0 No calculation
- 1 Complete parameterization
- 2 Calculation of the equivalent circuit diagram data
- 3 Calculation of V/f and Vector control
- 4 Calculation of the controller settings

For the complete parameterization (P0340 = 1), in addition to the motor and control parameters, parameters are also pre-assigned which refer to the motor rated data (for example, torque limits and reference quantities for interface signals). A complete list of all of the parameters depending on P0340 is included in the parameter manual.

---

#### **Note**

When exiting quick commissioning with P3900 > 0, internally P0340 is set to 1 (complete parameterization).

If the measurements of the motor data identification are completed, P0340 is internally set to 3.

---

Performing the calculation of motor and control data via BOP

Parameter	Description	Setting
P0340 = 1	<p><b>Calculation of motor parameters</b></p> <p>This parameter is required during commissioning in order to optimize the operating behavior of the inverter. For the complete parameterization (P0340 = 1), in addition to the motor/control parameters, parameters are pre-assigned which refer to the rated motor data (e.g. torque limits and reference quantities for interface signals). A list of the parameters, which are calculated, depending on the setting of P0340, are included in the parameter list.</p> <p>0: No calculation                      1: Complete parameterization (default)                      2: Calculation of equivalent circuit data                      3: Calculation of V/f and Vector control                      4: Calculation of controller settings only</p>	
If additional catalog data is known enter the data in P0341, P0342 and P0344.		
P0341 = ...	<b>Motor inertia [kg*m<sup>2</sup>]</b>	
P0342 = ...	<b>Total/motor inertia ratio</b>	
P0344 = ...	<b>Motor weight</b> (entered in kg)	
If the ECD data is known, enter the data in P0350, P0354, P0356, P0358, P0360. <b>If the ECD data is not known, then: Set P0340 = 4 to calculate the controller settings and skip to END.</b>		
P0350 = ...	<p><b>Stator resistance (line)</b> (entered in <math>\Omega</math>)</p> <p>Stator resistance in <math>\Omega</math> of the motor which is connected (line). This parameter value doesn't include the cable resistance.</p>	
P0352 = ...	<b>Cable resistance</b> cable resistance in $\Omega$ between inverter and motor for one phase	
P0354 = ...	<p><b>Rotor resistance</b> (entered in <math>\Omega</math>)</p> <p>Defines the rotor resistance of the motor equivalent diagram (phase value).</p>	
P0356 = ...	<p><b>Stator leakage inductance</b> (entered in mH)</p> <p>Defines the stator leakage inductance of the motor equivalent diagram (phase value).</p>	
P0358 = ...	<p><b>Rotor leakage inductance</b> (entered in mH)</p> <p>Defines the rotor leakage inductance of the motor equivalent diagram (phase value).</p>	
P0360 = ...	<p><b>Main inductance</b> (entered in mH)</p> <p>Defines the main (magnetizing) inductance of the motor equivalent diagram (phase value).</p>	
P0340 = 3	<p><b>Calculation of motor parameters</b></p> <p>3: Calculation of V/f and Vector control (default)</p> <p>All of the parameters, dependent on the ECD data are calculated and, in addition, the controller settings (P0340 = 4).</p>	
END	The motor parameters have been calculated and it is now possible to return to the additional parameterization in the Section "Commissioning the Application".	

### 5.5.3.3 Speed Control Optimization

#### Parameter settings

Parameter	Description
P0010 = 0	<b>Commissioning parameter filter*</b> Check if P0010 = 0 (Ready)
P1960 = 1	<b>Speed control optimization</b> 0: Disable (default) 1: Enable
ON command	<b>Start Speed control optimization</b> In case of vector mode (P1300 = 20 or 21) Speed Control Optimization is recommended. Once P1960 = 1, alarm A0542 is generated, that states, the next ON command will initiate the optimization. If there is a problem with speed control optimization due to instability the drive may trip with fault F0042, because no stable value has been obtained on the ramp up within a reasonable time. Note: When Speed control optimization is complete A0542 will be cleared and P1960 will be cleared to zero.

## 5.5.4 Commissioning the Application

### Overview

After the motor - inverter combination has been commissioned using quick commissioning, the following parameters should be set according to the requirements of the specific application. As an example, the following points should be considered:

- Functional requirements of the inverter (for example, closed-loop process control with PID controller)
- Limit values
- Dynamic requirements
- Starting torques
- Load surge requirement
- Overload
- Diagnostics

For information to functions refer to the Function Manual.

### Commissioning the application - step-by-step description

The parameters designated with an "\*" offer more setting options than are listed here. Refer to the Parameter Manual for additional settings. For detailed information refer to the Function Manual.

### General settings

Parameter	Description	Setting
P0003 = 3	<b>User access level*</b> 1: Standard: Allows access into most frequently used parameters (default) 2: Extended: Allows extended access e.g. to inverter I/O functions 3: Expert: For expert use only	
P0014 = ...	<b>Store mode</b> 0: Volatile (RAM) (default) 1: Nonvolatile (EEPROM)	
P0210 = ...	<b>Supply voltage</b> (enter the voltage in V) This parameter enters the real line supply voltage to which the Inverter is connected. Only necessary if P1254 = 0 (default: P1254 = 1).	
P0290 = 2	<b>Inverter overload reaction</b> This defines the response of the Inverter to an internal over temperature. 0: Reduce output frequency 1: Trip (F0004) 2: Reduce pulse frequency and output frequency (default) 3: Reduce pulse frequency then trip (F0004)	
P0335 = 0	<b>Motor cooling</b> (enter the motor cooling system) 0: Self-cooled using the shaft mounted fan attached to the motor (default) 1: Force-cooled using the separately powered cooling fan 2: Self-cooled and internal fan 3: Force-cooled and internal fan	



**Note**

If P0014=0 it is possible to transfer all parameter values from RAM into EEPROM via P0971. The duration of the data transfer depends on the number of changed parameters. The data transfer can last up to 3 minutes. During the data transfer, BOP displays "bUSY".

**Temperature Sensor**

Parameter	Description	Setting
P0601 = ...	<b>Motor temperature sensor</b> 0: No sensor (default; → P0610) 1: PTC thermistor (→ P0604)	
P0604 = ...	<b>Threshold motor temperature</b> (0 °C ... 220 °C, default 130 °C) Enter the warning threshold for motor over temperature protection. The trip temperature threshold (warning threshold + 10 %) is where either the inverter is tripped or I <sub>max</sub> is reduced (P0610).	
P0610 = 2	<b>Motor I2t temperature reaction</b> Defines the reaction when the motor temperature reaches the warning threshold. 0: No action, only a warning 1: Warning and I <sub>max</sub> reduced (this results in a reduced output frequency) 2: Warning and trip (F0011) (default)	

**Temperature calculation without sensor**

In the vector control mode (P1300 = 20/21/22/23) Temperature calculations is possible without sensor. The following parameters have to be set.

Parameter	Description (Parameter name and factory setting (if not variable) in bold)	Setting
P0621= 1	<b>Motor temperature identification after restart</b> 0: No identification (default) 1: Temperature identification only at first "motor on" after power cycle 2: Temperature identification at each motor on.	
P0622 = ...	<b>Motor magnetizing time for temperature identification after stator resistance identification</b> This parameter will be initialised with a value for one calculating cycle of the motor temperature. It depends on the identified rotor time constant. Due to accuracy reasons this calculation may be performed several times.	

**Selection of command source**

The available command sources depend on the used CU.

Default setting on the control unit used the command source is set per default to different values.

Parameter	Description	Setting
P0700 = 2/6	<p><b>Selection of command source</b>                      This selects the digital command source</p> <p>0: Factory default setting                      1: BOP (Basic Operator Panel)                      2: Terminals (default) (P0701 ... P0706), factory setting                      5: USS on RS485</p>	

**Assigning digital input functions**

Parameter	Description	Setting
P0701 = 1	<p><b>Terminal 5:</b>                      Digital Input 0 (DI0)</p>	Possible values for P0701 to P0706: 0: Digital input disabled 1: ON/OFF1 2: ON reverse /OFF1 3: OFF2 - coast to standstill 4: OFF3 - quick ramp-down 9: Fault acknowledge 10: JOG right 11: JOG left 12: Reverse 13: MOP up (increase frequency) 14: MOP down (decrease frequency) 15: Fixed frequency selector bit0 16: Fixed frequency selector bit1 17: Fixed frequency selector bit2 18: Fixed frequency selector bit3 25: DC brake enable 27: Enable PID 29: External trip 33: Disable additional freq setpoint 99: Enable BICO parameterization
P0702 = 12	<p><b>Terminal 6:</b>                      Digital Input 1 (DI1)</p>	
P0703 = 9	<p><b>Terminal 7:</b>                      Digital Input 2 (DI2)</p>	
P0704 = 15	<p><b>Terminal 8:</b>                      Digital Input 3 (DI3)</p>	
P0705 = 16	<p><b>Terminal 16:</b>                      Digital Input 4 (DI4)</p>	
P0706 = 17	<p><b>Terminal 17:</b>                      Digital Input 5 (DI5)</p>	
P0724 = 3	<p><b>Debounce time for digital inputs</b>                      Defines the debounce time (filtering time) used for digital inputs.</p> <p>0: No debounce time                      1: 2.5 ms debounce time                      2: 8.2 ms debounce time                      3: 12.3 ms debounce time (default)</p>	

### Assigning digital outputs

Parameter	Description	Setting
P0731 = 52:3	<b>BI: function of digital output 0 (DO0)</b> , defines the source for digital output 0 Terminal 18: DO0, NC/Terminal 19: DO0, NO/Terminal 20: DO0, COM52:3 Inverter fault active (default)	
P0732 = 52:7	<b>BI: function of digital output 1</b> , defines the source for digital output 1 Terminal 21: DO1, NO/Terminal 22: DO1, COM52:7 Inverter warning active (default)	
P0733 = 0:0	<b>BI: function of digital output 2</b> , defines the source for digital output 2 Terminal 23: DO0, NC/Terminal 24: DO0, NO/Terminal 25: DO0, COM0:0 Digital output disabled (default)	
P0748	<b>Invert digital outputs</b> Bits 0, 1 and 2 can be used to invert the signals of digital outputs 0, 1 and 2	

### Frequency setpoint set

Parameter	Description	Setting
P1000 = ?	<b>Selection of frequency setpoint</b> 0: No main setpoint 1: MOP setpoint (P1031 ... P1040) 2: Analog setpoint (P0756 ... P0762), factory setting 3: Fixed frequency (P1001 ... P1023) 5: USS on RS485 (P2010 ... P2019) 7: Analog setpoint 2 10: Additional setpoint (1 = MOP) + Main setpoint (0 = No main setpoint) 11: Additional setpoint (1 = MOP) + Main setpoint (1 = MOP) 12: Additional setpoint (1 = MOP) + Main setpoint (2 = Analog setpoint) ... 52: Additional setpoint (5 = USS on RS485)) + Main setpoint (2 = Analog setpoint) 53: Additional setpoint (5 = USS on RS485)) + Main setpoint (3 = Fixed frequency) ...	

### Frequency setpoint via MOP (P1000 = 1)

Parameter	Description	Setting
P1031 = 0	<b>Setpoint memory of the MOP</b> The last motorized potentiometer setpoint, which was active before the OFF command or switching-off, can be saved. 0: MOP setpoint will not be stored (default) 1: MOP setpoint will be stored in P1040	
P1032 = 1	<b>Inhibit reverse direction of MOP</b> 0: reverse direction is allowed 1: Reverse direction inhibited (default)	
P1040 = 5	<b>Setpoint of the MOP</b> Defines the setpoint [Hz] of the motorized potentiometer (MOP).	

Frequency setpoint via analog input (AI) (P1000 = 2)

Parameter	Description	Setting
P0756 = 0	<p><b>AI type</b>                      Defines the type of the analog input and also enables analog input monitoring.                      0: Unipolar voltage input (0 to +10 V) (default)                      1: Unipolar voltage input with monitoring (0 V ... +10 V)                      2: Unipolar current input (0 mA ... 20 mA)                      3: Unipolar current input with monitoring (0 mA ... 20 mA)                      4: Bipolar voltage input (-10 V ... +10 V)  <b>NOTE:</b> The following applies for P0756 ... P0760:                      Index 0: Analog input 0 (AI0), terminals 3 and 4                      Index 1: Analog input 1 (AI1), terminals 10 and 11</p>	
P0757 = 0	<b>Value x1 of AI scaling [V/mA]</b>	<p>P0761 &gt; 0                      0 &lt; P0758 &lt; P0760    0 &gt; P0758 &gt; P0760</p>
P0758 = 0.0	<b>Value y1 of AI scaling</b> this parameter represents the value of x1 as a percentage of P2000 (reference frequency)	
P0759 = 10	<b>Value x2 of AI scaling [V/mA]</b>	
P0760 = 100	<b>Value y2 of AI scaling</b> This parameter represents the value of x2 as a percentage of P2000 (reference frequency)	

### Frequency setpoint via fixed frequency (P1000 = 3)

Parameter	Description	Setting																																																
P1016 = 1	Fixed frequency mode, defines the selection method for fixed frequencies. 1: direct selection (default) 2: binary coded	<p>The fixed frequency can be selected via four digital inputs. As there are only three free DIs, P1023 is not connected to a DI. To select all possible FFs, it is necessary to use e.g. a AI as a DI (e.g. P1023 = 722.12).</p> <p><b>Fixed frequencies via direct selection (P1016 = 1):</b></p> <p>With the default settings additional combinations as follows are possible:</p> <table border="1" style="width: 100%; border-collapse: collapse;"> <thead> <tr> <th>Fixed Frequency selected via</th> <th>FF- Par</th> <th>FF [Hz]</th> </tr> </thead> <tbody> <tr> <td>DI3 (P1020 =722.3)</td> <td>P1001 (default = 0 Hz)</td> <td>0</td> </tr> <tr> <td>DI4 (P1021 =722.4)</td> <td>P1002 (default = 5 Hz)</td> <td>5</td> </tr> <tr> <td>DI5 (P1022 =722.5)</td> <td>P1003 (default = 10 Hz)</td> <td>10</td> </tr> <tr> <td>DI3, DI4</td> <td>P1001+P1002</td> <td>5</td> </tr> <tr> <td>DI3, DI5</td> <td>P1001+P1003</td> <td>10</td> </tr> <tr> <td>DI4, DI5</td> <td>P1002+P1003</td> <td>15</td> </tr> <tr> <td>DI3, DI4, DI5</td> <td>P1001+P1002+P1003</td> <td>15</td> </tr> </tbody> </table> <p><b>Fixed frequencies via binary coded selection (P1016 = 2):</b></p> <p>With binary coded selection each frequency, set in one of the parameters P1001 ... P1015 can be directly selected.</p> <table border="1" style="width: 100%; border-collapse: collapse;"> <thead> <tr> <th>Fixed Frequency selected via</th> <th>FF- Par</th> <th>FF-default setting [Hz]</th> </tr> </thead> <tbody> <tr> <td>DI3 (P1020 =722.3)</td> <td>P1001</td> <td>0</td> </tr> <tr> <td>DI4 (P1021 =722.4)</td> <td>P1002</td> <td>5</td> </tr> <tr> <td>DI5 (P1022 =722.5)</td> <td>P1003</td> <td>10</td> </tr> <tr> <td>DI3, DI4</td> <td>P1005</td> <td>20</td> </tr> <tr> <td>DI4, DI5</td> <td>P1006</td> <td>25</td> </tr> <tr> <td>DI3, DI5</td> <td>P1008</td> <td>35</td> </tr> <tr> <td>DI3, DI4, DI5</td> <td>P1011</td> <td>50</td> </tr> </tbody> </table>	Fixed Frequency selected via	FF- Par	FF [Hz]	DI3 (P1020 =722.3)	P1001 (default = 0 Hz)	0	DI4 (P1021 =722.4)	P1002 (default = 5 Hz)	5	DI5 (P1022 =722.5)	P1003 (default = 10 Hz)	10	DI3, DI4	P1001+P1002	5	DI3, DI5	P1001+P1003	10	DI4, DI5	P1002+P1003	15	DI3, DI4, DI5	P1001+P1002+P1003	15	Fixed Frequency selected via	FF- Par	FF-default setting [Hz]	DI3 (P1020 =722.3)	P1001	0	DI4 (P1021 =722.4)	P1002	5	DI5 (P1022 =722.5)	P1003	10	DI3, DI4	P1005	20	DI4, DI5	P1006	25	DI3, DI5	P1008	35	DI3, DI4, DI5	P1011	50
Fixed Frequency selected via	FF- Par		FF [Hz]																																															
DI3 (P1020 =722.3)	P1001 (default = 0 Hz)		0																																															
DI4 (P1021 =722.4)	P1002 (default = 5 Hz)		5																																															
DI5 (P1022 =722.5)	P1003 (default = 10 Hz)		10																																															
DI3, DI4	P1001+P1002		5																																															
DI3, DI5	P1001+P1003		10																																															
DI4, DI5	P1002+P1003		15																																															
DI3, DI4, DI5	P1001+P1002+P1003		15																																															
Fixed Frequency selected via	FF- Par		FF-default setting [Hz]																																															
DI3 (P1020 =722.3)	P1001		0																																															
DI4 (P1021 =722.4)	P1002		5																																															
DI5 (P1022 =722.5)	P1003		10																																															
DI3, DI4	P1005		20																																															
DI4, DI5	P1006		25																																															
DI3, DI5	P1008	35																																																
DI3, DI4, DI5	P1011	50																																																
P1001 = 0	<b>Fixed frequency 1, (FF1)</b> Value given in Hz.																																																	
P1002 = 5	<b>Fixed frequency 2</b>																																																	
P1003 = 10	<b>Fixed frequency 3</b>																																																	
P1004 = 15	<b>Fixed frequency 4</b>																																																	
P1005 = 20	<b>Fixed frequency 5</b>																																																	
P1006 = 25	<b>Fixed frequency 6</b>																																																	
P1007 = 30	<b>Fixed frequency 7</b>																																																	
P1008 = 35	<b>Fixed frequency 8</b>																																																	
P1009 = 40	<b>Fixed frequency 9</b>																																																	
P1010 = 45	<b>Fixed frequency 10</b>																																																	
P1011 = 50	<b>Fixed frequency 11</b>																																																	
P1012 = 55	<b>Fixed frequency 12</b>																																																	
P1013 = 60	<b>Fixed frequency 13</b>																																																	
P1014 = 65	<b>Fixed frequency 14</b>																																																	
P1015 = 65	<b>Fixed frequency 15</b>																																																	
P1020 = 722.3	<b>Fixed frequency selection - Bit 0</b> Selects DI3 for FF selection																																																	
P1021 = 722.4	<b>Fixed frequency selection - Bit 1</b> Selects DI4 for FF selection																																																	
P1022 = 722.5	<b>Fixed frequency selection - Bit 2</b> Selects DI5 for FF selection																																																	
P1023 = 0	<b>Fixed frequency selection - Bit 3</b>																																																	

Analog outputs

Parameter	Description	Setting
P0771 = 21	<p><b>CI: Analog output</b>                      Defines the function of the 0 mA ... 20 mA analog output                      21: CO: actual frequency (default; scaled according to P2000)                      24: CO: actual output frequency (scaled according to P2000)                      25: CO: actual output voltage (scaled according to P2001)                      26: CO: actual DC-link voltage (scaled according to P2001)                      27: CO: Output current (scaled according to P2002)  <b>NOTE:</b> The following applies for P0771 ... P0785:                      Index 0: analog output 0 (AO0), terminals 12 and 13                      Index 1: analog output 1 (AO1), terminals 26 and 27</p>	
P0775 = 0	<p><b>Permit absolute value</b>                      Decides if the absolute value of the analog output is used.                      If enabled, this parameter will take the absolute value of the value to be outputted.                      If the value was originally negative then the corresponding bit in r0785 is set.</p>	
P0776 = 0	<p><b>Type of analog output</b>                      Scaling of r0774.                      0: Current output (default)                      1: Voltage output  <b>NOTE:</b> P0776 changes over the scaling of r0774 (0 mA ... 20 mA <math>\leftrightarrow</math> 0 V ... 10 V).                      Scaling parameters P0778, P0780 and the deadband are always entered in 0 mA ... 20 mA.                      Analog output 0 can be switched to a voltage output with a range 0 ... 10 V.                      Analog output 1 is only a current output. When it is used as voltage output, it must be terminated using a 500 <math>\Omega</math> resistor.</p>	
P0777 = 0.0	<p><b>Value x1 of the analog output scaling</b>                      Defines x1 output characteristic in percentage. This parameter represents the lowest analog value as a percentage of P200x (depending on the setting of P0771).</p>	
P0778 = 0	<p><b>Value y1 of the analog output scaling</b>                      This parameter represents the value of x1 in mA.</p>	
P0779 = 100	<p><b>Value x2 of the analog output scaling</b>                      This defines x2 of the output characteristic in percentage.                      This parameter represents the highest analog value as a percentage of P200x (depending on the setting of P0771).</p>	
P0780 = 20	<p><b>Value y2 of the analog output scaling</b>                      This parameter represents the value of x2 in mA.</p>	
P0781 = 0	<p><b>Width of analog output deadband</b>                      This sets the width of the deadband in mA for the analog output.</p>	

### JOG frequency

Parameter	Description	Setting
P1057 = 1	<b>JOG Enable</b> P1057 = 0 JOG-function disabled P1057 = 1 JOG-function enabled (default)	
P1058 = 5	<b>JOG frequency right</b> Frequency in Hz when the motor is being jogged in the clockwise direction.	
P1059 = 5	<b>JOG frequency left</b> Frequency in Hz when the motor is being jogged in the counter-clockwise direction.	
P1060 = 45	<b>JOG ramp-up time</b> Ramp-up time in seconds from 0 to the maximum frequency (P1082). The JOG ramp-up is limited by P1058 or P1059.	
P1061 = 50	<b>JOG ramp-down time</b> Ramp-down time in seconds from the maximum frequency (P1082) to 0.	

### Additional Setpoints

Parameter	Description	Setting
P1074 = 1.0	<b>BI: disable additional setpoint</b>	
P1075 = 775	<b>CI: additional setpoint</b> Defines the source of the additional setpoint which is added to the main setpoint. <b>Common settings:</b> 755: Analog input setpoint 1024: Fixed frequency setpoint 1050: MOP setpoint	
P1076 = 1.0	<b>CI: additional setpoint scaling</b> Defines the source to scale the additional setpoint. <b>Common settings:</b> 1: Scaling of 1.0 (100 %) 755: Analog input setpoint 1024: Fixed frequency setpoint 1050: MOP setpoint	

### Skip Frequency

Parameter	Description	Setting
P1091 = 7.5	<b>Skip frequency 1</b> (entered in Hz) Avoids mechanical resonance effects and suppresses (skips) frequencies in the range around the skip frequency $\pm$ P1101 (skip frequency bandwidth).	<p>The graph shows a dashed line representing the intended frequency ramp. A solid line shows the actual output frequency <math>f_{out}</math> which deviates from the dashed line to skip a range of frequencies. The skip frequency is labeled P1091, and the bandwidth of the skip is indicated by P1101. The y-axis is labeled <math>f_{out}</math> and the x-axis is labeled t.</p>
P1092 = 0.0	<b>Skip frequency 2</b>	
P1093 = 0.0	<b>Skip frequency 3</b>	
P1094 = 0.0	<b>Skip frequency 4</b>	
P1101 = 1.0	<b>Skip frequency bandwidth</b> (entered in Hz)	

### Ramp times

Parameter	Description	Setting
P1120 = 10	<b>Ramp-up time</b> Enter the acceleration time in seconds.	<p>The graph shows a trapezoidal frequency profile. The y-axis is labeled f and the x-axis is labeled t. The maximum frequency is labeled P1082 (<math>f_{max}</math>). The frequency at the start of the ramp-down is labeled <math>f_t</math>. The time for the ramp-up is labeled P1120 and the time for the ramp-down is labeled P1121.</p>
P1121 = 10	<b>Ramp-down time</b> Enter the deceleration time in seconds.	

### Rounding

Parameter	Description	Setting
P1130 = 5.0	<b>Ramp-up initial rounding time</b> (in seconds)	<p>The rounding times are recommended, to avoid abrupt responses and so to minimize stress to the mechanical system. The ramp-up and ramp-down times are extended by the component of the rounding ramps.</p>
P1131 = 5.0	<b>Ramp-up final rounding time</b> (in seconds)	
P1132 = 5.0	<b>Ramp-down initial rounding time</b> (in seconds)	
P1133 = 5.0	<b>Ramp-down final rounding time</b> (in seconds)	
P1134 = 0	<b>Rounding type</b> 0: continuous smoothing (jerk-free) 1: Discontinuous smoothing <b>NOTE:</b> for discontinuous rounding (P1134 = 1), after the setpoint is reduced or an OFF1 command, the final rounding at ramp-up (P1131) and the initial rounding at ramp-down (P1132) are not executed.	



### Further parameters to set before finishing the application commissioning

The following parameters should be configured for each application.

Parameter	Description	Setting
P1800 = 4	<p><b>Pulse frequency</b> (kHz)</p> <p>The pulse frequency can be changed in 2 kHz steps. The range extends from 4 kHz up to 16 kHz. The complete inverter output current at 50 °C is reached with 4 kHz.</p> <p>The maximum output frequency depends on the pulse frequency. Operation up to 266 Hz is possible with a pulse frequency of 4 kHz. If a higher output frequency is required, then the pulse frequency should also be increased (10 kHz pulse frequency - maximum output frequency of 650 Hz)</p> <p>If low-noise operation is not required, then the inverter losses and the high-frequency disturbances emitted by the inverter can be reduced by selecting lower pulse frequencies.</p>	
P2000 = 50	<p><b>Reference frequency</b> (Hz)</p> <p>The reference frequency in Hertz corresponds to a value of 100 %.</p> <p>This setting should be changed if a maximum frequency of higher than 50 Hz is required.</p> <p><b>NOTE:</b> This scaling acts on the maximum frequency of the analog setpoints, the fixed frequencies and the motorized potentiometer. All these values refer to 100 %.</p>	
P2001 = 1000	<p><b>Reference voltage</b> (V)</p> <p>The reference voltage in Volts (output voltage) corresponds to a value of 100 %.</p> <p><b>NOTE:</b> This setting should only be changed if it is necessary to output the voltage with another scaling.</p>	
P2002 = ...	<p><b>Reference current</b> (A)</p> <p>The reference current in Amperes (output current) corresponds to a value of 100 %. Factory setting is 200 % of the rated motor current (P0305).</p> <p><b>NOTE:</b> This setting should only be changed if it is necessary to output the current with another scaling.</p>	
P2003 = ...	<p><b>Reference torque</b> (Nm)</p> <p>The reference torque in Newton-meters corresponds to a value of 100 %. Factory setting is 200 % of the rated motor torque, determined from the motor data, for a constant motor torque.</p> <p><b>NOTE:</b> This setting should only be changed if it is necessary to output the torque with another scaling.</p>	
P2004 = ...	<p><b>Reference power</b> (kW or hp)</p> <p>The reference power in kW or hp corresponds to a value of 100 %. Factory setting is 200 % of the rated motor power at constant motor torque.</p> <p>This setting should only be changed if it is necessary to output the power with another scaling.</p>	

### Finishing the application commissioning

Parameter	Description	Setting
P0971 = 1	<p><b>Transfer data from RAM to EEPROM</b></p> <p>0: Disabled (default)</p> <p>1: Start data transfer, RAM → EEPROM</p> <p>All of the parameter changes are transferred from RAM (volatile) into the EEPROM (nonvolatile, settings are not lost with power off).</p> <p>While the transfer is active, "bUSY" is displayed on the BOP. Once the transfer is completed P0970 will be set internally to "0" and the "P0970" will be displayed.</p> <p><b>Note:</b> Data transfer RAM → EEPROM is not necessary when the commissioning is performed via the BOP, because all parameter changes via BOP are stored as well in RAM as in EEPROM immediately.</p>	

### 5.5.5 Reset Parameters to Factory Settings

#### Overview

With a factory reset via P0970 the initial state of the all the inverter parameters can be re-established.

The factory setting values are designated as "Factory setting" in the Parameter Manual.

For further information, refer to the section "Factory Settings of the Control Unit" in this manual.

---

#### Note

When resetting the parameters to the factory setting, the communications memory is re-initialized. This means that communications are interrupted for the time it takes to perform the reset.

---

 <b>WARNING</b>
--------------------------------------------------------------------------------------------------

<p><b>Parameter reset in case of CUs with fail-safe functions</b></p>
-----------------------------------------------------------------------

<p>Parameters that don't relate to fail-safe functions are reset with P0970 = 1.</p>
--------------------------------------------------------------------------------------

<p>To reset parameters that relate to fail-safe functions an additional parameter reset with P0970 = 10 must be performed. This parameter reset is password protected.</p>
----------------------------------------------------------------------------------------------------------------------------------------------------------------------------

<p>In case of a parameter reset with P0970 = 10 an acceptance test necessary.</p>
-----------------------------------------------------------------------------------

#### Reset to the factory setting

Parameter or action	Description
P0003 = 1	<b>User access level*</b> 1: Standard: Allows access into most frequently used parameters.
P0004 = 0	<b>Parameter filter</b> 0: All parameters
P0010 = 30	<b>Commissioning parameter*</b> 30: Factory setting, parameter transfer
P0970 = 1	<b>Factory reset*</b> 1: Parameter reset to the default values
BUSY (on BOP) Progress bar (STARTER)	When the factory reset has been finished, P0970 and P0010 are set to 0 and the BOP changes back to the standard display.

---

#### Note

The following parameters will not be changed with a factory reset:

- P0014 Store mode
  - P0100 Europe / North America
  - P0201 power stack code number
  - Communication parameters
  - Data depending on actual Power Module
-

## 5.5.6 Series commissioning using the BOP

### Upload and download a parameter set with a BOP

With a BOP a single parameter set can be uploaded from an inverter and then downloaded into another inverter.

To copy a parameter set from one inverter to another, the following procedure should be performed.

### Upload a parameter set with a BOP

#### Prerequisites

- An inverter with an appropriate parameter set is available (upload inverter)
- Supply voltage is active for the upload inverter
- The upload inverter is in "Ready State".

Parameter	Description	Setting
	<b>Fit the BOP to the Inverter - for the parameter set to be uploaded, perform the following steps:</b>	
P0003 = 3	<b>User access level*</b> 1: Standard: Allows access into most frequently used parameters (default) 2: Extended: Allows extended access e.g. to inverter I/O functions 3: Expert: For expert use only	
P0010 = 30	<b>Commissioning parameter*</b> 0: Ready (default) 1: Quick commissioning 2: Inverter 30: Factory setting, parameter transfer 95: Safety commissioning (for CUs with fail-safe functions only)	
P0802 = 1	<b>Transfer data from EEPROM</b> 0: Disabled (default) 1: Start BOP transfer  While the upload is active "bUSY" will be displayed on the BOP and the inverter will not react to any commands.	
	If the upload has been completed successfully, P0010 and P0802 will be set to 0 and the BOP display will return to normal. If the upload has failed, F00051 (failure while accessing EEPROM), F00055 (failure while saving parameter on BOP) or F00057 (BOP fault) will be displayed. In this case attempt another upload or perform a power-cycle to confirm F00051.	
	<b>After a successful upload disconnect the BOP from the upload inverter to connect it to the download inverter.</b>	

**Download a parameter set with a BOP**

**Prerequisites**

- Supply voltage is active for the download inverter
- The download inverter is in "Ready State".

Parameter	Description	Setting
	<b>Fit the BOP to the inverter and perform the download according the flow chart.</b>	
P0003 = 3	<b>User access level*</b> 1: Standard: Allows access to the most frequently used parameters (default) 2: Extended: Allows extended access e.g. to inverter I/O functions 3: Expert: For expert use only	
P0010 = 30	<b>Commissioning parameter*</b> 0: Ready (default) 1: Quick commissioning 2: Inverter 30: Factory setting, parameter transfer 95: Safety commissioning (for CUs with fail-safe functions only)	
P0803 = 1	<b>Transfer data to EEPROM</b> 0: Disabled (default) 1: Start BOP transfer  While the download is active "bUSY" will be displayed on the BOP and the inverter will not react to any commands.	
	If the download has been completed successfully, P0010 and P0803 will be set to 0 and the BOP display will return to normal. If the download has failed, F00051 (failure while accessing EEPROM), F00055 (failure while saving parameter to EEPROM), F00057 (BOP fault) or F00058 (BOP contents incompatible) will be displayed. In this case attempt another download, perform a factory reset to allow the inverter to return to a known state or perform a power-cycle to confirm F00051.	
	<b>After a successful download the BOP can be removed and connected to another inverter for download. Then perform the download steps again until the series commissioning has been completed for all inverters.</b>	

## 5.6 Commissioning with STARTER

### Interfaces STARTER

A PC with STARTER software can be connected via one of the following interfaces - which are Control Unit dependent:

Table 5-6 Connection possibilities for STARTER

Type	Connection
PC connected via "Option port" with a PC Connection Kit	Peer to peer
PC connected via terminals	Up to 32 inverter slaves

### General information for connecting STARTER

USS address: see P2011, default setting P2011 = 0

USS baudrate: see P2010, default setting P2010 = 8 ( $\cong$  38400 baud)

### 5.6.1 Single Commissioning with STARTER

#### STARTER projects

Using STARTER either a new project can be created or an already existing project can be opened.

To create a new project in STARTER one of the following methods can be used:

- Search inverter
- Wizard
- Select inverter

When opening an existing project or creating a new project STARTER is in the offline mode. To go online the button  has to be pressed.

#### Changing parameters with STARTER

Parameters can be changed online or offline (online preferred).

Online parameter changes are stored in the RAM of the inverter. A manual transfer from RAM to EEPROM can be triggered by pressing the button . When closing STARTER and the contents of the RAM and EEPROM are different, the user is asked whether or not they wish to transfer the RAM data to the EEPROM.

Parameter sets that have been changed offline can be transferred to the inverter using the download  button.

 **CAUTION**

If you use fail-safe applications, pay attention to the following note:



- Parameters for fail-safe functions can only be changed in the online mode.  
When downloading parameters via STARTER, parameters belonging to fail-safe functions will not be downloaded.

## 5.6.2 Series Commissioning with STARTER

### Upload a parameter set with STARTER

#### Prerequisites

- An inverter with an appropriate parameter set is available (upload inverter)
- STARTER is installed on the PC used for series commissioning
- Supply voltage is active for the upload inverter
- The upload inverter is in "Ready to Run".

Connect the STARTER PC via the Option Port (USS on RS232, peer to peer) to the upload inverter (PC connection Kit required), press the online button  and perform the upload by activating the button .

---

#### Note

##### Upload with STARTER to the BOP



If you want to upload a parameter set with STARTER to the BOP, P0010, P0802 must be set via the expert list.

---

### Download a parameter set with STARTER

#### Prerequisites

- Supply voltage is active for the download inverter
- The download inverter is in "Ready to Run".

Connect the STARTER PC via the Option Port (USS on RS232, peer to peer) to the download inverter (PC connection Kit required), press the online button  and perform the download by activating the button . The data set must be saved in the EEPROM.

---

#### Note

##### Download with STARTER to the BOP

If you want to perform a manual download of a parameter set with STARTER from the BOP, P0010, P0803 and P0804 must be set via the expert list.

---

## 5.7 Parameters

### Overview of parameters

The inverter is adapted to a particular application using the corresponding parameters. This means that each parameter is identified by a parameter number and specific attributes (e.g. monitoring parameter, write parameter, BICO attribute, group attribute etc.). Within any one particular inverter system, the parameter number is unique.

Parameters can be accessed using the following operator units:

- BOP
- PC-based commissioning (start-up) tool STARTER.

There are two main types of parameters; those that can be altered and those that are read-only.

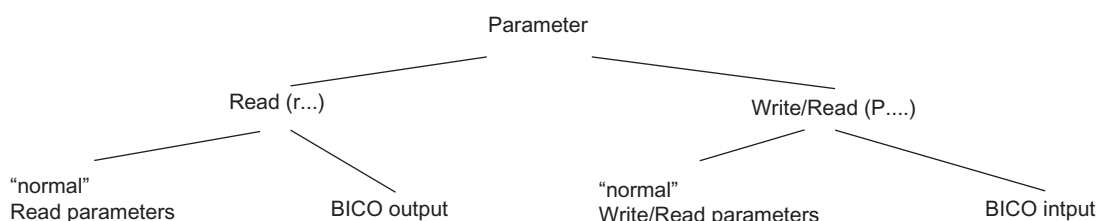

Figure 5-3 Parameter types

### 5.7.1 Write parameters

#### Description

Parameters which can be written into and displayed are indicated by the prefix "P".

These parameters directly influence the behavior of a function. The value of this parameter is saved in non-volatile memory (EEPROM) as long as the appropriate option was selected (non-volatile data save). Otherwise, these values are saved in the volatile memory (RAM) of the processor, which are lost after power failure or power-off/power-on operations.

Examples of the standard notation used throughout our manuals is given below.

#### Notation examples:

P0970	parameter 970
P0748.1	parameter 748, bit 01
P0819[1]	parameter 819 index 1
P0013[0 ... 19]	parameter 13 with 20 indices (indices 0 to 19)

### 5.7.2 Monitoring parameters

#### Description

Parameters which can only be monitored are indicated by the prefix "r".

These parameters are used to display internal quantities, for example states and actual values.

#### Notation examples:

r0002	monitoring parameter 2
r0052.3	monitoring parameter 52, bit 03
r0947[2]	monitoring parameter 947 index 2
r0964[0 ... 4]	monitoring parameter 964 with 5 indices (indices 0 to 4)

### 5.7.3 Parameter Attributes

#### Overview

In the Parameter Manual, the header line of each parameter shows all the attributes and groups for that specific parameter. The figure below shows the details for parameter P0700 and r1515.

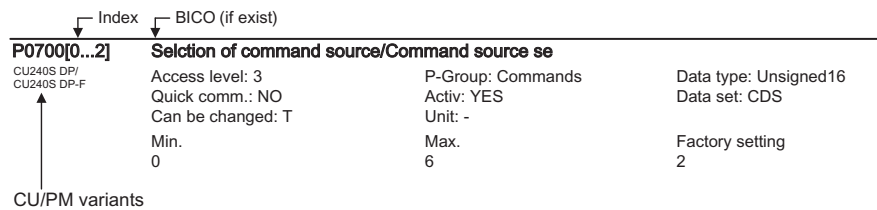

Figure 5-4 Description of attributes for parameter P0700

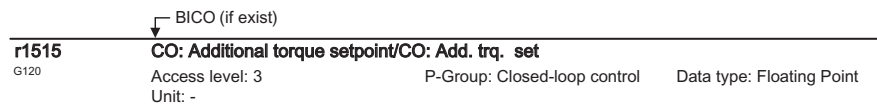

Figure 5-5 Description of attributes for parameter r1515



## Index

Using the index, a parameter (e.g. p0013[20]) is defined with several consecutive elements (in this case, 20). Each individual index is defined using a numerical value.

When transferred to a parameter this means that an indexed parameter can have several values. The values are addressed using the parameter number including the index value (e.g. p0013[0], p0013[1], p0013[2], p0013[3], p0013[4], ...).

Indexed parameters are used, for example:

- Drive Data Sets (DDS)
- Command Data Sets (CDS)
- Sub functions.

## BICO

The following types of connectable parameters are available. A description of BICO technology is given in the section "BICO Technology".

Table 5-7 Parameter attributes - BICO

BICO	Description
BI	Binector Input
BO	Binector Output
CI	Connector Input
CO	Connector Output
CO/BO	Connector Output/Binector Output

## Access level

The access level is controlled using parameter P0003. In this case, only those parameters are visible at the BOP, where the access level is less than or equal to the value assigned in parameter P0003. On the other hand, for STARTER, only access levels 0 and 3 are relevant. For example, parameters with access level 3 cannot be changed, if the appropriate access level has not been set.

The following access levels are implemented in the inverters:

Table 5-8 Parameter attributes - access level

Access level	Description
0	User-defined Parameter Manual (refer to P0013)
1	Standard access to the most frequently used parameters
2	Extended access, e.g. to inverter I/O functions
3	Expert access only for experienced users
4	Service access only for authorized service personnel – with password protection.

**Note**

In STARTER, all user parameters (access stage 3) are always displayed using the expert list – independent of the setting p0003 = 0, 1, 2 or 3.

When changing parameters using STARTER, or via a higher-level control system, parameter value changes always become immediately effective.

**Can be changed**

"P" parameters can only be changed depending on the inverter state. The parameter value is not accepted if the instantaneous state is not listed in the parameter attribute "Can be changed". For instance, the quick commissioning parameter P0010 with the attribute "CT" can only be changed in quick commissioning "C" or ready "T" but not in operation "U".

Table 5-9 Parameter attributes - Can be changed

State	Description
C	Quick commissioning
U	Operation (Drive running)
T	Drive ready to run

**Data types**

The data type of a parameter defines the maximum possible value range. Five data types are used for the inverter. They either represent an unsigned integer value (U16, U32) or a floating-point value (float). The value range is frequently restricted by a minimum and maximum value (min, max) or using inverter/motor quantities.

Table 5-10 Parameter attributes - Data types

Data type	Description
U16	Unsigned, integer value with a size of 16 bits
U32	Unsigned, integer value with a size of 32 bits
I16	Signed integer 16-bit value
I32	Signed integer 32-bit value
Float	A simple precise floating point value according to the IEEE standard format max. value range: -3.39e+38 –+3.39e+38

## Unit

The values of parameters support the following units:

Table 5-11 Parameter attributes - Unit

Unit	Description	Unit	Description
-	No dimension	m/s	Meters per second
%	Percentage	Nm	Newton meter
A	Ampere	W	Watt
V	Volt	kW	Kilowatt
Ohm	Ohm	Hp	Horse power
us	Microseconds	kWh	Kilowatt hours
ms	Milliseconds	°C	Degrees Celsius
s	Seconds	m	Meter
Hz	Hertz	kg	Kilograms
kHz	Kilohertz	°	Degrees (angular degrees)
1/min	Revolutions per minute [RPM]		

## Grouping

The parameters are sub-divided into groups according to their functionality. This increases the transparency and allows a quicker and more efficient search for specific parameters. Furthermore, parameter P0004 can be used to control the specific group of parameters that are displayed on the BOP.

Table 5-12 Parameter attributes - Grouping

Grouping	Description		Main parameter area:
ALWAYS	0	all parameters	
INVERTER	2	inverter parameters	0200 ... 0299
MOTOR	3	motor parameters	0300 ... 0399 and 0600 ... 0699
ENCODER	4	speed encoder	0400 ... 0499
TECH_APL	5	technical applications/units	0500 ... 0599
COMMANDS	7	control commands, digital I/O	0700 ... 0749 and 0800 ... 0899
TERMINAL	8	Analog inputs/outputs	0750 ... 0799
SETPOINT	10	Setpoint channel and ramp-function gen.	1000 ... 1199
Safety integrated	11	Fail-safe functions	9000 ... 9999
FUNC	12	Inverter functions	1200 ... 1299
CONTROL	13	Motor open-loop/closed-loop control	1300 ... 1799
COMM	20	Communications	2000 ... 2099
ALARMS	21	Faults, warnings, monitoring functions	0947 ... 2199
TECH	22	Technology controller (PID controller)	2200 ... 2399

**Active**

This attribute is only of importance in conjunction with an BOP. The "Yes" attribute indicates that this value is immediately accepted when it is changed. Especially parameters which are used for optimization functions have this property (e.g. constant voltage boost P1310 or filter time constants). On the other hand, for parameters with the attribute "First confirm", the value is only accepted after first pressing the key **P**. These include, for example, parameters where the parameter value can have different settings/meanings (e.g. selecting the frequency setpoint source P1000).

Table 5-13 Parameter attributes - Active

Active	Description
Yes	The value becomes valid immediately.
First confirm	The value becomes valid after pressing <b>P</b>

**Note**

Parameter values that are changed using STARTER or a higher-level control do not have to be acknowledged.

**Quick commissioning**

This parameter attribute identifies as to whether the parameter is included in the quick commissioning (QC) (P0010 = 1).

Table 5-14 Parameter attributes - Quick commissioning

QC	Description
No	The parameter is not included in the quick commissioning
Yes	The parameter is included in the quick commissioning

**Value range**

The value range, which is first specified by the data type, is restricted by minimum and maximum values depending on the quantities of the inverter/motor. The values min and max are permanently saved in the inverter and cannot be changed by the user. To support commissioning each write parameter has a default value called factory setting.

Table 5-15 Parameter attributes - Value range

Value range	Description
-	No value entered (e.g.: "r parameter")
Min	Minimum value
Max	Maximum value
Def	Default value

## Data sets

A detailed description for the data sets is given in the respective section

Table 5-16 Data sets

<b>BICO</b>	<b>Description</b>
CDS	Command data set
DDS	Drive data set

## 5.8 Start-up and Swap Behavior of the Inverter

### 5.8.1 Normal Start-up Behavior of the Inverter

#### Start-up

A normal start-up is a start-up after a power-cycle or a black-out. At a normal start-up the inverter reads the parameters from EEPROM to RAM.

If a component (CU or PM) has been replaced, this is called a swap and the start-up behavior is described in the following.

### 5.8.2 Swap Behavior of the Inverter

#### Swap types

The following swaps are allowed:

- CU Swap (neither PM nor CU powered)
- PM Swap (neither PM nor CU powered)
- PM Swap (CU externally powered)

#### CU Swap, PM Swap (neither PM nor CU powered)

- Swap after power on detected, Parameter EEPROM -> RAM, inverter runs into F00395
- Commissioning recommended - otherwise inverter runs with parameter settings from EEPROM

#### PM Swap (CU externally powered)

- Swap detected, Parameter EEPROM -> RAM, inverter runs into F00395
- If the parameters, already held in the EEPROM are ok there is no commissioning necessary.

---

#### Note

After a PM Swap the parameter settings only stored in RAM will be lost.

---

## Rules regarding swap and hot swap

### Note

F00395 cannot be cleared via power cycle.

There are a number of scenarios where a swap is allowed, each with their own unique set of conditions that must be observed.

### DANGER

#### Do not attempt to hot swap a power module (PM)

Before attempting to swap a PM it must be fully powered-down. Any attempt to swap-out a PM when power is still applied could result in death of personnel and severe damage to property and equipment.

### WARNING

#### Swap restrictions

Before performing a swap take care of the following:

- only CUs of the same type are swapped
- only PMs of the same type and power rating are swapped.
- the application is in a safe state before any swap of equipment is performed.

## CU Swap

The following procedure is given as a guide to perform a swap of a CU.

Before performing a CU Swap take care of the following:

1. The PM is powered-down and disconnected.
2. Wait 5 minutes to allow the unit to discharge after switching off the line supply.
3. Disconnect the wiring from the CU (mark the cables with the terminal numbers).
4. Remove the CU from the PM.

Before switching on power supply to the inverter take care of that:

1. Fit the new CU to the PM.
2. Reconnect the wiring to the CU.

## PM Swap

 <b>CAUTION</b>
--------------------------------------------------------------------------------------------------

To ensure complete data set compatibility, make sure that all parameters are stored in the EEPROM of the Control Unit (see P0014 or P0971) prior to swapping the PM).
-----------------------------------------------------------------------------------------------------------------------------------------------------------------------

Before performing a PM Swap take care of the following:

1. The PM is powered-down and disconnected.
2. Wait 5 minutes to allow the unit to discharge after switching off the line supply.

Before switching on Power supply take care of that:

1. The new PM is properly installed and connected.
2. The CU is fitted back on the PM.

## See also

Message F00395 (Page 35)



## Communication via USS

### 6.1 Universal serial interface (USS)

#### Data

Parameter range:	P2010 ... r2037
Warnings:	–
Faults:	F0071, F0072
Function chart number:	FP2500, FP2510, FP2600, FP2610

#### Overview

Using the Universal Serial Interface (USS) protocol, a user can establish a serial point-to-point data link (RS232 interface) and a serial bus data link between a higher-level master system and several slave systems (RS485 interface). Master systems can be e.g. PLCs (e.g. SIMATIC S7-200) or PCs. The inverters are always the slaves on the bus system.

The USS protocol allows the user to implement both automation tasks with cyclical telegram traffic (a fixed telegram length is necessary) as well as visualization tasks. In this case, the protocol with variable telegram length is advantageous, as texts and parameter descriptions can be transferred in one telegram without chopping up the information.

#### USS via RS232

With the RS232 interface only direct connections (point-to-point) are possible with cable lengths of 2 m ... 5 m typically. This is typically used to commission a drive where the commissioning software (e.g. STARTER) runs on a PC. For this configuration the optional PC Connection Kit is available.

USS via RS485

With the RS485 interface communication networks can be constructed. The topology must be that of a line with the first and last devices of the line terminated with termination resistors.

The figure shows the RS485 terminals (29/30) and the termination DIP switch on the CU240E. Default position is OFF (no termination resistor).

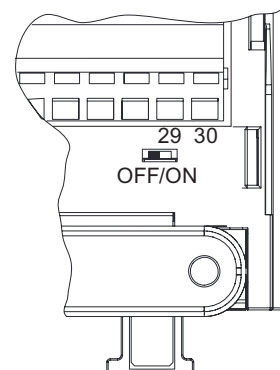

Short branches are possible to connect the devices. Up to 31 inverters can be integrated as slaves into a network with a PLC as master.

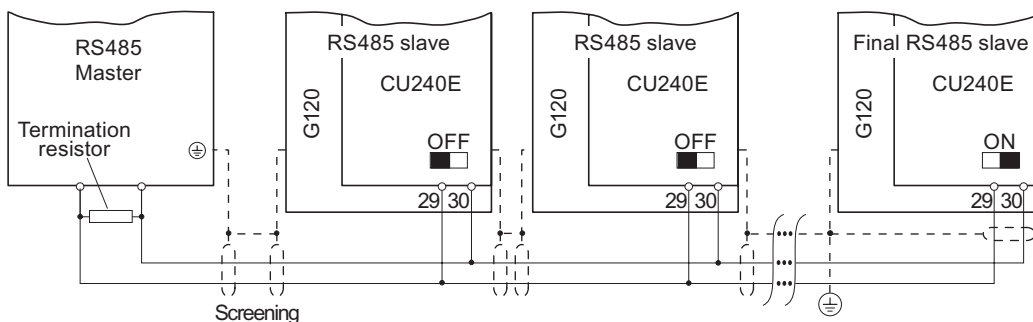

Figure 6-1 USS network via RS485

<b>⚠ CAUTION</b>
A difference in earth potential between master and the slaves in an RS485 network can cause damage to the Control Unit of the Inverter. Care must be taken to ensure that the master and slaves all have the same ground level.

Cable Lengths and number of devices

Table 6-1 Max. number of devices and max. cable length

Baudrate in bit/s	Max Number of Devices	Max Cable Length
9600	32	1200 m
19200	32	1200 m
38400	32	1200 m
57600	32	1200 m
115200 (maximum baudrate)	30	1000 m

## 6.2 Structure of a USS Telegram

### Description

The following figure shows the structure of a typical USS telegram.

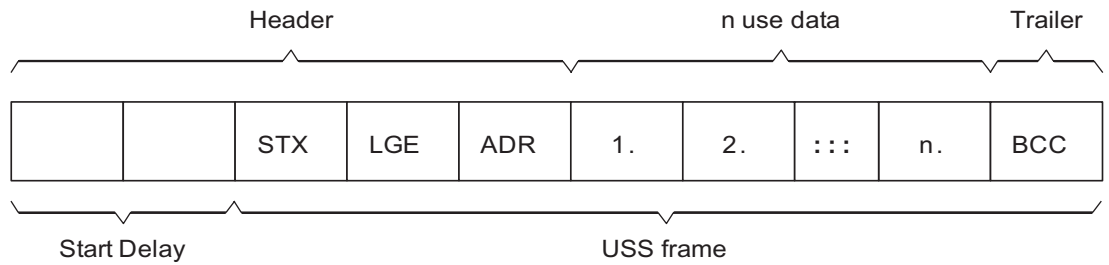

Figure 6-2 Structure of USS telegram

Variable length telegrams and fixed length telegrams can both be used. This can be selected using parameters P2012 and P2013 to define the PZD and PKW lengths.

The most common fixed length application is shown below:

STX	1 Byte	
LGE	1 Byte	
ADR	1 Byte	
use data	PKW	8 Bytes (4 Words: PKE + IND + PWE1 + PWE2)
	PZD	4 Bytes (2 Words: PZD1 + PZD2)
BCC	1 Byte	
Sum :	16 Bytes	(LGE indicates 14 bytes as STX and LGE are not counted in LGE)

### Start Delay

The length of the start delay is at least the time of two characters and depends on the baudrate.

Table 6-2 Length of start delay

Baudrate in bit/s	Transfer time per character (= 11 bit)	Transfer time per bit	Min. Start Delay
9600	1.146 ms	104.170 $\mu$ s	> 2.291 ms
19200	0.573 ms	52.084 $\mu$ s	> 1.146 ms
38400	0.286 ms	26.042 $\mu$ s	> 0.573 ms
57600	0.191 ms	17.361 $\mu$ s	> 0.382 ms
115200	0.059 ms	5.340 $\mu$ s	> 0.117 ms

Note: The time between characters must be smaller than the start delay.

**STX**

The STX field is a single byte ASCII STX character (0x02) used to indicate the start of a message.

**LGE**

The LGE is a single byte field, indicating the number of bytes which follow this in the telegram. It is defined as the sum of

- use data characters (quantity n)
- address byte (ADR)
- block check character (BCC)

The actual total telegram length will of course be two bytes longer as STX and LGE itself are not counted in the LGE.

**ADR**

The ADR field is a single byte containing the address of the slave node (e.g. inverter). The individual bits in the address byte are addressed as follows:

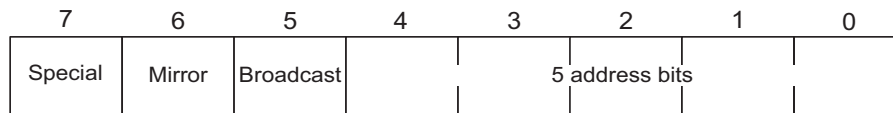

- Bit 5 is the broadcast bit.  
If it is set to 1, the message is a broadcast message and will be acted upon by all inverters on the serial link. The node address is not evaluated. The USS protocol specification requires certain settings in the PKW area, refer to the later example on using USS broadcast mode.
- Bit 6 = 1 indicates a mirror telegram.  
The node address is evaluated and the addressed slave returns the telegram unchanged to the master.

Bit 5 = 0 and bit 6 = 0 and bit 7 = 0 means normal data exchange for units. The node address (bit 0 ... bit 4) is evaluated.

**BCC**

BCC means block check character. It is an exclusive OR (XOR) checksum over all telegram bytes except the BCC itself.

## 6.3 Use data area of USS telegram

### Basic USS parameters

General rule: Index[0] for USS on RS485, Index[1] for USS on RS232.

- P2010 USS Baudrate [2400 ... 115200] baud
- P2011 USS Slave Address: [0 ... 30]
- P2012 USS PZD Length: [0 ... 2 ... 8] words
- P2013 USS parameter channel length: [0, 3 (3 words), 4 (4 words), 127 (variable length)]
- P2014 USS Telegram Off-Time: [0 ... 65535] ms. '0' = no timeout check!
- R2015 Received PZD via USS on RS232
- P2016 BICO Selection for PZDs to be sent via USS on RS232
- R2018 Received PZD via USS on RS485
- P2019 BICO Selection for PZDs to be sent via USS on RS485
- r2032 Control Word 1 from USS on RS232
- r2033 Control Word 2 from USS on RS232
- r2036 Control Word 1 from USS on RS485
- r2037 Control Word 2 from USS on RS485

### Use data structure

The use data area of the USS protocol is used for transferring the application data, which are the parameter channel and process data (PZD).

The application data occupies the bytes within the USS frame (STX, LGE, ADR, BCC). The size of the application data can be configured by parameters p2013 and p2012. The following figure shows the structure and order for the parameter channel and process data (PZD).

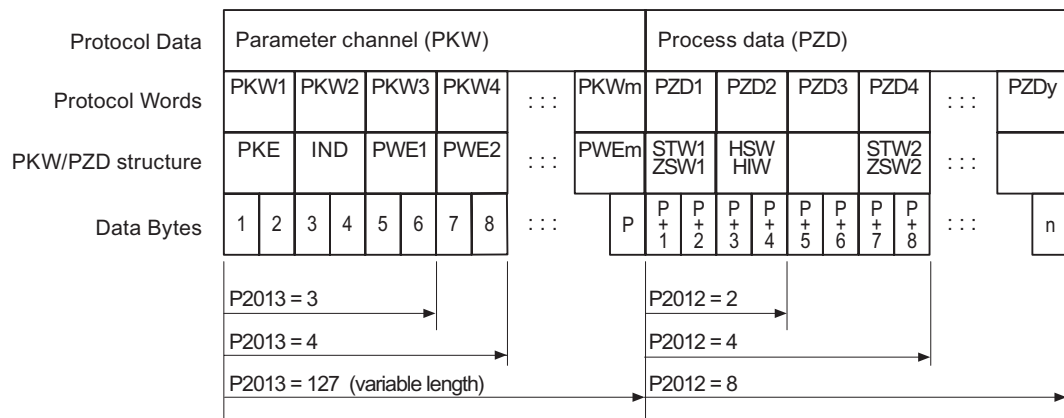

Figure 6-3 USS use data structure

The length of the parameter channel is determined by parameter P2013, that for the process data by parameter P2012. If either no parameter channel or no PZD is required, the corresponding parameters can be set to zero ("PKW only" or "PZD only" respectively).

It is not possible to transmit "PKW only" and "PZD only" alternatively. If both channels are required they must be transferred together.

## 6.4 Data Structure of the USS Parameter Channel

### Description

The USS protocol defines the use data structure for the inverters, with which a master can access the inverters (slaves). The parameter channel can be used to monitor and/or change any parameter in the inverter.

### Parameter channel

Using the parameter channel process data can be processed and monitored (write/read) as described below. The parameter channel can be parameterized for a fixed length with 3 or 4 words or for a variable length.

Parameter identifier (PKE) is contained in the first word always, parameter index in the second one.

Parameter values, texts and descriptions are contained in words 3, 4 and the following.

### Parameter identifier (PKE), 1st word

The parameter identifier (PKE) is always a 16-bit value.

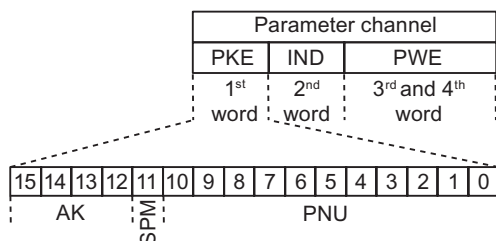

Figure 6-4 PKE structure

- Bits 0 to 10 (PNU) contain the remainder of the parameter number (value range 1 to 61999).

For parameter numbers  $\geq 2000$  it is necessary to add an offset which is defined with the high byte bits of IND.

- Bit 11 (SPM) is reserved and always = 0.
- Bits 12 to 15 (AK) contain the request or the response identifier.

The meaning of the request identifier for request telegrams (master → inverter) is shown in the table below.

Table 6-3 Request identifier (master → inverter)

Request identifier	Description	Response identifier	
		positive	negative
0	No request	0	7 / 8
1	Request parameter value	1 / 2	7 / 8
2	Modify parameter value (word)	1	7 / 8
3	Modify parameter value (double word)	2	7 / 8
4	Request descriptive element <sup>1)</sup>	3	7 / 8
6	Request parameter value (array) <sup>1)</sup>	4 / 5	7 / 8
7	Modify parameter value (array, word) <sup>1)</sup>	4	7 / 8
8	Modify parameter value (array, double word) <sup>1)</sup>	5	7 / 8
9	Request number of array elements	6	7 / 8
11	Modify parameter value (array, double word) and store in EEPROM <sup>2)</sup>	5	7 / 8
12	Modify parameter value (array, word) and store in EEPROM <sup>2)</sup>	4	7 / 8
13	Modify parameter value (double word) and store in EEPROM	2	7 / 8
14	Modify parameter value (word) and store in EEPROM	1	7 / 8
1) The desired element of the parameter description is specified in IND (2nd word)			
2) The desired element of the indexed parameter is specified in IND (2nd word)			

The meaning of the response identifier for response telegrams (inverter → master) is shown in the table below. The request identifier will determine which response identifiers are possible.

Table 6-4 Response identifier (inverter → master)

Response identifier	Description
0	No response
1	Transfer parameter value (word)
2	Transfer parameter value (double word)
3	Transfer descriptive element <sup>1)</sup>
4	Transfer parameter value (array word) <sup>2)</sup>
5	Transfer parameter value (array double word) <sup>2)</sup>
6	Transfer number of array elements
7	Cannot process request, task cannot be executed (with error number)
8	No master control status / no parameter change rights for PARAMETER CHANNEL interface
1) The desired element of the parameter description is specified in IND (2nd word)	
2) The desired element of the indexed parameter is specified in IND (2nd word)	

If the response identifier is 7 (cannot process request), then one of the fault numbers listed in the next table will be stored in parameter value 2 (PWE2).

Table 6-5 Fault numbers for "Cannot process request" response

No.	Description	Remarks
0	Illegal parameter number (PNU)	Parameter does not exist
1	Parameter value cannot be modified	Parameter is a read-only parameter
2	Minimum/maximum not reached/exceeded	-
3	Faulty subindex	-
4	No array	Single parameter has been accessed with array request and subindex > 0
5	Parameter type is wrong / incorrect data type	Mix-up between word and double word
6	Setting not allowed (resetting only)	-
7	Descriptive element cannot be modified	Description can never be modified
11	No status as master control	Modification request without status as master control (see P0927)
12	Key word missing	-
17	Request cannot be processed due to operating state	Current inverter status is not compatible with the received request
101	Parameter number currently deactivated	Dependent on inverter status
102	Channel not wide enough	Communication channel too small for response
104	Illegal parameter value	Parameter permits only certain values
106	Request not implemented / Task not supported	After request identifier 5, 10, 15
200/201	Modified minimum/maximum not reached/exceeded	Minimum/maximum can be further limited in operation
204	Available access authorization does not cover modification of parameters	-

**Parameter index (IND) 2<sup>nd</sup> word**

The array subindex is in the PROFIdrive Profile referred to simply as "subindex".

**Structure for acyclical communication**

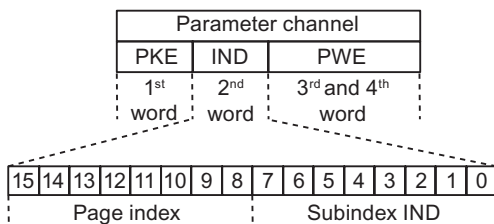

Figure 6-5 IND structure

- The array subindex is an 8-bit value which is transferred in the low-order byte (bits 0 to 7) of the parameter index (IND).
- The parameter page selection task for additional parameters is performed in this case by the high-order byte (bits 8 to 15) of the parameter index. This structure conforms to the USS specification.

Example: Coding for parameter no. in PKE and IND for "P2016, Index 3".

PKE		IND		PWE1		PWE2	
xx	10	80	03				



**Regulation for the parameter range**

The bit for parameter page selection functions as follows:

If it is set to 1, an offset of 2000 is applied in the inverter to the parameter number (PNU) transferred in the parameter channel request before it is passed on.

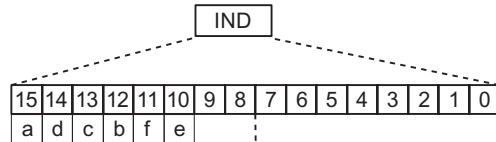

Figure 6-6 IND page index

Table 6-6 Regulation for setting the PNU

Parameter range	Page index						Bit		Hex value	+ PNU
	a	d	c	b	f	e	9	8		
0000 ... 1999	0	0	0	0	0	0	0	0	0x00	0 – 7CF
2000 ... 3999	1	0	0	0	0	0	0	0	0x80	0 – 7CF
4000 ... 5999	0	0	0	1	0	0	0	0	0x10	0 – 7CF
6000 ... 7999	1	0	0	1	0	0	0	0	0x90	0 – 7CF
8000 ... 9999	0	0	1	0	0	0	0	0	0x20	0 – 7CF
...	...	...	...	...	...	...	...	...	...	...
32.000 ... 33.999	0	0	0	0	0	0	1	0	0x04	0 – 7CF
...	...	...	...	...	...	...	...	...	...	...
64.000 ... 65.999	0	0	0	0	1	0	0	0	0x08	0 – 7CF

Table 6-7 Example coding for parameter no. in PKE and IND for P8820, Index 16

	PKE		IND	
decimal	xx	820	32	16
hex	xx	334	20	10

### Parameter value (PWE)

For communication via USS, the number of PWEs can vary. For 16 bit values one PWE is required. If 32 bit values are exchanged, two PWEs are required.

---

#### Note

Data types U8 will be transferred as U16 with the upper byte zero. Arrays of U8 will therefore require one PWE per index.

---

A parameter channel for 3 words is a typical data frame for exchanging 16 bit data or alarm messages. The mode with a fixed word length of 3 is used with  $p2013 = 3$ .

A parameter channel for 4 words is a typical data frame for exchanging 32 bit data variables and requires  $p2013 = 4$ .

A parameter channel for a flexible word length is used with  $p2013 = 127$ . The length for telegrams between master and slave can have a different number of PWEs.

If the length of the parameter channel is fixed ( $p2013 = 3$  or  $4$ ), then the Master must always correctly send either 3 or 4 words in the parameter channel. Otherwise, the slave will not respond to the telegram. The slave response will be either 3 or 4 words as well. If a fixed length is used, this should be 4, as 3 would not be sufficient to support many of the parameters (i.e. double words). For variable length of the parameter channel ( $p2013 = 127$ ) the master sends only the necessary number of words for the task in the parameter channel. The length of the response telegram will also only be as long as necessary.

### Rules for processing requests/responses

- A request or a response can only ever refer to one parameter.
- The master must repeat a request continuously until it has received the appropriate response.
- The master detects the response to a request it has sent by
  - evaluating the response identifier,
  - evaluating the parameter number PNU,
  - evaluating the parameter index IND if necessary, or
  - evaluating the parameter value PWE if necessary.
- The complete request must be sent in one telegram. Request telegrams cannot be split. The same applies to responses.
- In the case of response telegrams which contain parameter values, the drive always returns the current parameter value when repeating response telegrams.

## 6.5 Timeouts and other errors

### Telegram Timeouts

For the timeout monitoring, the character run time is important:

Table 6-8 Character run time

Baudrate in bit/s	Transfer time per character (= 11 bit)	Transfer time per bit	Character run time
9600	1.146 ms	104.170 us	1.146 ms
19200	0.573 ms	52.084 us	0.573 ms
38400	0.286 ms	26.042 us	0.286 ms
115200	0.059 ms	5.340 us	0.059 ms

The following figure shows the meaning of the "residual run time":

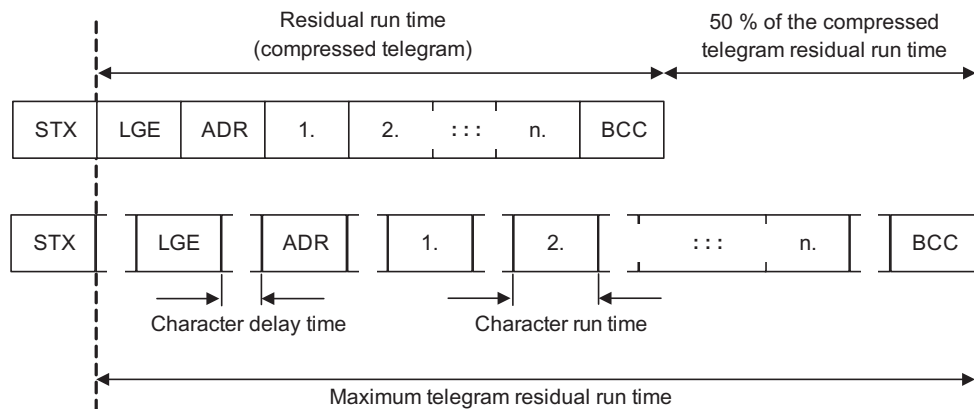

Figure 6-7 Residual Run Time and Character Delay Time

The character delay time can be zero and must be smaller than the start delay!

The following figure shows the various delays and transmission times:

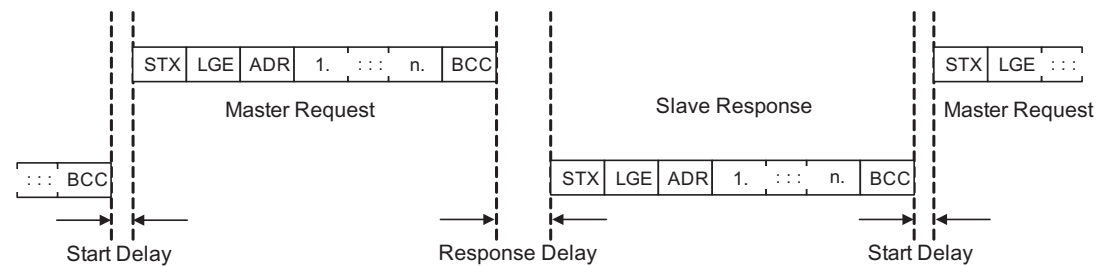

Figure 6-8 Start Delay and Response Delay

Character delay time	timeout between characters and must be smaller than 2 time the character run time but can be zero
Start delay	timeout between USS messages. Must be $> 2 \cdot$ character run time
Response delay	Processing time of the slave. Must be $< 20$ ms, but larger than the start delay!
Residual run time	$< 1.5 \cdot (n + 3) \cdot$ character run time (where $n =$ number of data bytes)
"Slave Transmitting"/ "Master Transmitting"	is the sum of "Start delay", "Response delay" and "Residual run time"

**The master must check the following times:**

- "Response delay" = reaction time of slave to USS request
- "Residual run time" = transmission time of response telegram sent by slave

**The slave must check the following times:**

- "Start delay" = timeout between USS messages
- "Residual run time" = transmission time of request telegram coming from master

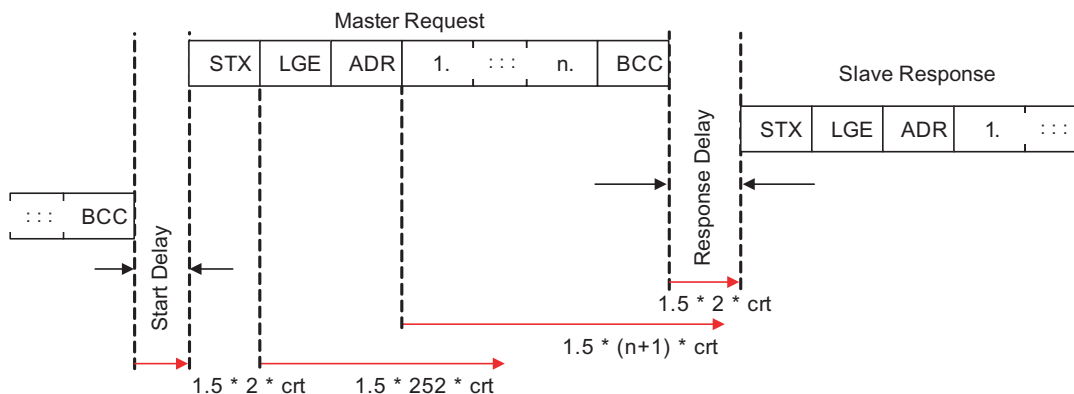

Figure 6-9 Timeout Checks on USS Slave

The timeout margins that are verified on the USS slave are shown in the figure above. "crt" stands for "character run time". The factor "1.5" is the maximum margin. The "start delay" and the minimum "response delay" are fixed minimum values in software. The "residual run times" are monitoring values that cause a timeout if they are exceeded by the character reception.

**Process Timeouts**

Parameter P2014 determines the timeout in ms. A value of zero disables the timeout check. Parameter P2014 checks the cyclic refresh of Bit10 in control word 1.

When USS is configured as command source of the drive and P2014 is not zero, Bit10 of the received control word 1 is examined. If the bit is not set, an internal timeout counter is incremented. If the threshold of p2014 is reached, a process timeout fault is set by the drive.

### Other errors

- P2025 = USS rejected
- P2026 = USS character frame error
- P2027 = USS overrun error
- P2028 = USS parity error
- P2029 = USS start not identified
- P2030 = USS BCC error
- P2031 = USS length error

## 6.6 USS Process Data Channel (PZD)

### Description

In this area of the telegram, process data (PZD) are continually exchanged between the master and slaves. Dependent of the direction the process data channel contains data for a request to the USS slaves or for a response to the USS master. In the requests are control words and setpoints for the slaves and in the responses are status words and actual values for the master.

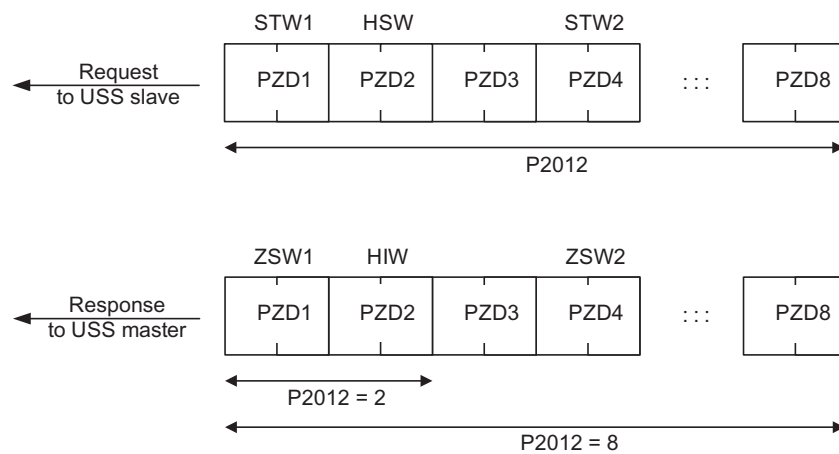

Figure 6-10 Process data channel

The number of PZD words in a USS-telegram are determined by parameter P2012, where the first two words are:

- Control word 1 (STW1) and main setpoint (HSW)
- Status word 1 (ZSW1) and actual value (HIW)

If P2012 is greater or equal to 4 the additional control word (STW2) is transferred as the 4<sup>th</sup> PZD word (default setting).

The sources of all other PZDs are defined with parameter P2019 for a RS485 interface and P2016 for a RS232 interface.



## Operation

### 7.1 ON/OFF Commands

The G120 inverter provides the following ON/OFF commands:

- ON / OFF (ON/OFF1)
- Coast stop (OFF2)
- Quick stop (OFF3)

#### Description

##### ON / OFF (ON/OFF1)

The ON/OFF1 function is an inter-coupled command. When the ON command is withdrawn, then OFF1 is directly activated.

- Frequency setpoint = 0

The inverter ramps down to standstill in the period of time set in P1121.

- If parameterized, the motor holding brake is closed (P1215) when zero speed is detected. When the brake application time (P1217) expires, the pulses are suppressed.

Zero speed is detected, if one of the following events occur:

- The actual speed drops below the Switch-off frequency (P2167).
- The monitoring time (P1227), started when the speed setpoint  $\leq$  Switch-off frequency (P2167), has expired.

##### Coast stop (OFF2)

- Instantaneous pulse suppression, the drive coasts to a standstill.
- If parameterized, the motor holding brake is closed immediately.
- Power-on inhibit is activated.

Before restarting, an OFF2 must be confirmed, e. g. via the key FN on the BOP. For certain applications, it is useful to link the confirmation of an OFF2 or an OFF3 to the ON/OFF function.

---

##### Note

If after a period of time, set in P1227, an OFF1 or an OFF3 has been unable to ramp down the motor to Switch-off frequency (P2167), the system forces an immediate OFF2.

---

**Quick stop (OFF3)**

- Frequency setpoint = 0
- The inverter ramps down to standstill in the period of time set in P1135.
- If parameterized, the motor holding brake is closed, when zero speed is detected. When the brake application time (P1217) expires, the pulses are suppressed.

Zero speed is detected, if one of the following events occur:

- The actual speed drops below the Switch-off frequency (P2167).
  - The monitoring time (P1227), started when the speed setpoint  $\leq$  speed threshold (P2167), has expired.
- Power-on inhibit is activated.

Before restarting, OFF3 must be confirmed, e. g. via the key FN on the BOP.

 <b>CAUTION</b>
--------------------------------------------------------------------------------------------------

If in sensless vector mode, for example, due to an overload of the motor the inverter loses orientation. It will not be possible to switch off using an OFF1 or an OFF3 command. In this case it is necessary to initiate an OFF2 command or disable the pulses using P0054.3.
--------------------------------------------------------------------------------------------------------------------------------------------------------------------------------------------------------------------------------------------------------------------------------

 <b>DANGER</b>
--------------------------------------------------------------------------------------------------

During power off, hazardous loads must be secured by a motor holding brake. To avoid severe personal injury and property damage, make sure, that a motor holding brake is established in the drive system. Use SINAMICS G120 brake sequence control (P1215, P0346, P1216, P1217, P1080) to control the motor holding brake during power off.
----------------------------------------------------------------------------------------------------------------------------------------------------------------------------------------------------------------------------------------------------------------------------------------------------------------------------------------------



### Sources for ON/OFF command

Digital input 0 (DI0) is the default setting for the ON/OFF command.

In addition the following sources are selectable via P0700:

- Digital inputs (P0700 = 2)
- BOP (P0700 = 1)
- STARTER (P0700 = 4)
- A higher-level control system (P0700 = 6)



Refer to Commissioning section for details.

### ON/OFF via digital inputs (DI)

The ON/OFF functions require a permanent signal.

### ON/OFF via BOP

To power the inverter ON/OFF, press the following keys on the BOP:

 (Green)	ON	
 (Red)	OFF1	Press once
	OFF2	Press twice or pressing once for a longer period of time

### ON/OFF via a higher-level control system

Via a serial interface, the inverter is switched ON/OFF using a higher-level control system (e.g. SIMATIC S7).

---

#### Note

The 2-/3-wire control provides special ON/OFF methods. For detailed information, refer to the Function Manual.

---

## 7.2 Operation States Displayed via LED

### 7.2.1 LED Display

#### Status display

The CU240E provides two LEDs to show the operating state of the inverter.

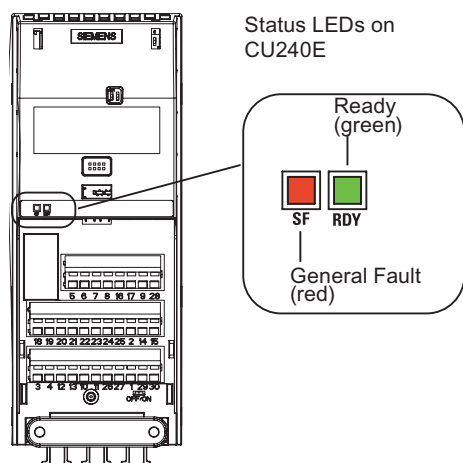

Figure 7-1 LED Status CU240E

#### LEDs on a CU240E

- System-Fault LED (SF)
  - **ON**: A general system error either software or hardware related is indicated.
  - **Flashing**: Download runs
- Ready LED (RDY)
  - **ON**: The inverter is ready to run or running.
  - **Flashing**: Commissioning or download runs

### 7.2.2 LED States

#### CU states displayed via LED

CU240E	Prio	SF	RDY
Commissioning	1	Red / Black	Green / Black
Parameter download	1	Red / Black	Green / Black
General faults	1	Red	Black
Ready	3	Black	Green

# Troubleshooting

## 8.1 Faults and Alarms

### Description

The inverter indicates unfavourable states as faults and alarms.

- **Alarms**

Alarms are not displayed via the LEDs on the Control Unit. Alarms require no acknowledgement and cause no systems reaction. The alarm number is displayed on STARTER or a higher-level control system.

- **Faults**

Faults indicate a severe unfavourable state. If a fault occurs, the inverter powers off and the LED "SF" on the Control Unit is active.

The fault number is displayed on BOP, STARTER or a higher-level control system. The inverter cannot be restarted unless the fault is remedied. After remedy the fault requires an acknowledgement.

---

**Note**

For detailed descriptions of the faults and alarms, refer to the Parameter Manual.

---

### Parameterizing faults and alarms

#### Faults

For fault handling, regard the following parameters:

- Stored in parameter r0947 under their code number, e. g. F0003 = 3
- Associated error value stored in parameter r0949 (0 = no error value)
- Time stamp of the fault stored in r0948 and can be read out
- Number of fault messages (P0952) is stored in r0947 and can be read out

## Alarms

For alarm handling, regard the following parameter:

- Stored in parameter r2110 under their code number and can be read out, e. g. A0503 = 503. The value 0 indicates, that no warning is applied. Via the index, access to the two actual alarms and the last two historical alarms is provided.

## Display

Faults and alarms are displayed on the following components:

- BOP  
The status display of the BOP indicates the occurring faults and alarms. If several messages arise, the display scrolls constantly through all active faults.
- STARTER  
The detail view in the alarms tab displays information, faults and alarms in the table. In the field "messages" the fault or information/alarm text is displayed in plain text.
- A higher-level control system. For detailed information, refer the respective manual of the control system.

## General acknowledgement of faults

To reset the fault code, one of the following methods can be used:

- Power cycle the inverter.  
(Switch OFF/ON the main supply voltage and the external 24 V supply for the Control Unit.)
- Press the key **FN** on the BOP.
- Activate the default setting of DI 2.
- Set bit 7 in control word 1 (r0054).

## Special acknowledgement of faults

The following faults messages can only be acknowledged by a power cycle:

- **F00051** Parameter EEPROM fault
- **F00052** Power stack fault
- **F00061** Swap fault
- **F00062** Swap fault
- **F00063** Swap fault
- **F00064** Drive attempted to do an Automatic Download during startup
- **F01601** System startup error

---

### Note

The drive cannot resume operation until all active faults have been acknowledged. Clearing F00395 is described in the section "Message F00395" of this manual.

---

## 8.2 Diagnostics Display

### Overview

The G120 inverter provides the following types of diagnostic display:

- LEDs on the Control Unit

A detailed overview on the LED states is given in section "Operation States displayed via LED" in this manual.

- Alarm and fault numbers

Use the alarm and fault numbers for troubleshooting via BOP and STARTER. For details for troubleshooting with STARTER, refer to the respective online help.

## 8.3 Troubleshooting with the BOP

### Diagnostics using alarm and fault numbers

The BOP must be fitted to the Control Unit. If an alarm or fault condition occurs, the BOP displays appropriate alarm or fault number.

If an alarm occurs the alarm number is displayed and the inverter will continue to run, although it is possible that it may run in an unexpected manner depending upon the alarm condition.

If a fault occurs, the fault number is displayed and the inverter is stopped.

If a line supply failure interrupts commissioning, then inconsistencies can occur regarding the parameterization. In this case, it is important that the commissioning is re-started with a factory reset to establish the original factory settings.

### Motor failure without fault or warning message

If the motor fails to start when the ON command has been given:

- Check that P0010 = 0.
- Check the inverter state via r0052.
- Check command and setpoint source (P0700 and P1000).
- Check, if the motor data relate to the inverter data power range and voltage.

---

#### Note

For troubleshooting, pay regard to the "Installation Check List" in the chapter "Installation" of this manual.

---



## Service and maintenance

### 9.1 Service and support information

#### A&D Technical support

24-hour technical support is provided by three main centers worldwide.

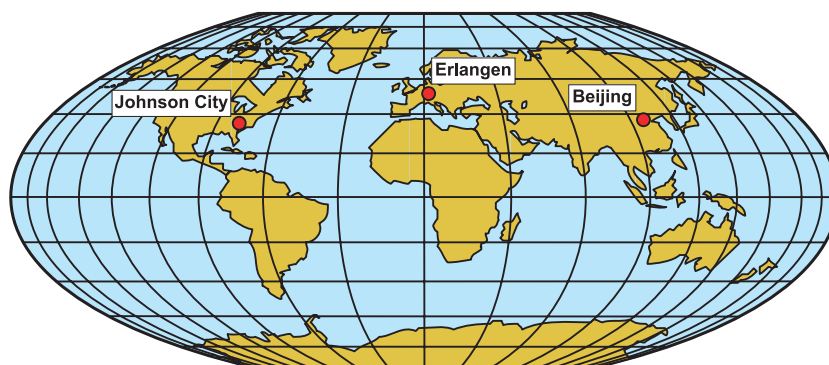

Figure 9-1 A&D Global service and support

#### Online Service and support

In the first instance for customer-support, contact should always be made with the regional (country based) sales/marketing/service organisations.

<http://support.automation.siemens.com>

For technical-support, the most optimised way to do this is via the Internet based Support-Request.

<http://www.siemens.com/automation/support-request>

#### Europe/Africa (Erlangen)

Internet Support-Request: <http://www.siemens.com/automation/support-request>

Tel: +49 (180) 5050 222

Fax: +49 (180) 5050 223

e-Mail: [support.automation@siemens.com](mailto:support.automation@siemens.com)

### **America (Johnson City)**

Internet Support-Request: <http://www.siemens.com/automation/support-request>

Tel: +1 (423) 262 2552

Fax: +1 (423) 262 2589

e-Mail: [support.usa.automation@siemens.com](mailto:support.usa.automation@siemens.com)

### **Asia/Pacific (Beijing)**

Internet Support-Request: <http://www.siemens.com/automation/support-request>

Tel: +86 (1064) 757 575

Fax: +86 (1064) 747 474

e-Mail: [support.asia.automation@siemens.com](mailto:support.asia.automation@siemens.com)

### **Contact address**

Should any questions or problems arise while reading this manual, please contact Siemens at the following address:

Siemens AG  
Automation & Drives  
A&D SD SPA PM4  
Postfach 3269  
D-91050 Erlangen  
Germany

e-Mail: [documentation.sd@siemens.com](mailto:documentation.sd@siemens.com)

### **Regional contacts**

For questions regarding services, prices and conditions of technical support, please contact your local Siemens partner.



## Technical data

### 10.1 CU240E Performance ratings

#### SINAMICS G120 Control Unit 240 (CU240)

Table 10-1 CU240 Performance ratings

Feature	Specification
Operating voltage	24 V DC from Power Module
Control method	<ul style="list-style-type: none"> <li>• V/f control, output frequency between 0 Hz and 650 Hz:               <ul style="list-style-type: none"> <li>– Linear V/f control,</li> <li>– Linear V/f control with FCC,</li> <li>– Parabolic V/f control,</li> <li>– Multi-point V/f control,</li> <li>– V/f control for textile applications,</li> <li>– V/f control with FCC for textile applications,</li> <li>– V/f control with independent voltage setpoint,</li> </ul> </li> <li>• Vector control, output frequency between 0 Hz and 200 Hz:               <ul style="list-style-type: none"> <li>– Sensorless Vector Control,</li> <li>– Sensorless Vector Torque Control.</li> </ul> </li> </ul>
Fixed frequencies	16 programmable
Skip frequencies	4 programmable
Setpoint resolution	0.01 Hz digital; 0.01 Hz serial; 10 bit analog (motor potentiometer 0.1 Hz [0.1 % in PID mode])
Digital inputs	6 programmable, isolated; PNP/NPN switchable, SIMATIC-compatible, low < 5 V, high > 10 V, maximum input voltage 30 V
Analog inputs	2 programmable, both configurable as additional digital inputs. <ul style="list-style-type: none"> <li>• AI0: 0 V ... 10 V, 0/4 mA ... 20 mA and -10 V ... +10 V</li> <li>• AI1: 0 V ... 10 V, 0/4 mA ... 20 mA</li> </ul>
Relay outputs	3 programmable, 30 V DC / 0 A ... 0.5 A (resistive) Current limiting must be provided via external user circuit.
Analog outputs	2 programmable AO0: 0 V ... 10 V & 0 mA ... 20 mA, AO1: 0 mA ... 20 mA
Dimensions (BxHxD)	73 mm x 195 mm x 37 mm
Weight	0.21 kg



## Spare parts/Accessories

### 11.1 Basic Operation Panel

The BOP is a parameterization tool that is fitted directly to the SINAMICS G120 inverter via the option port. It can also be used for up and download of parameter sets. For a detailed description refer to chapter "Commissioning using the BOP".

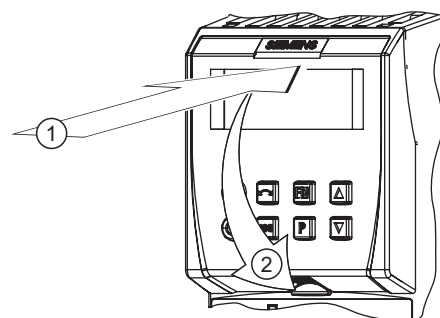

### 11.2 PC Connection Kit

The PC connection kit consists of a PC inverter connector module with a 9-pin sub-D socket and a null modem cable allowing connection to a PC running STARTER software.

Using this equipment it is possible to provide the following operations:

- To parameterize the inverter (Commissioning, optimizing)
- To monitor the inverter (Diagnosis)
- To control the inverter (For the purpose of testing, STARTER has the priority to control)



# A

## Appendix

### A.1 Electromagnetic Compatibility

#### Electromagnetic compatibility

All manufacturers/assemblers of electrical apparatus which "performs a complete intrinsic function and is placed on the market as a single unit intended for the end user" must comply with the EMC directive EC/89/336.

There are three routes for the manufacturer/assembler to demonstrate compliance:

#### Self-certification

This is a manufacturer's declaration that the European standards applicable to the electrical environment for which the apparatus is intended have been met. Only standards that have been officially published in the Official Journal of the European Community can be cited in the manufacturer's declaration.

#### Technical construction file

A technical construction file can be prepared for the apparatus describing its EMC characteristics. This file must be approved by a 'Competent Body' appointed by the appropriate European government organization. This approach allows the use of standards that are still in preparation.

#### EMC Standards

The SINAMICS G120 drives have been tested in accordance with the EMC Product Standard EN 61800-3:2004.

## A.2 Definition of the EMC Environment and Categories

### Classification of EMC performance

The EMC environment and categories are defined within the EMC Product Standard EN 61800-3, as follows:

#### First Environment

An environment that includes domestic premises and establishments that are connected directly to a public low-voltage power supply network without the use of an intermediate transformer.

---

**Note**

For example: houses, apartments, commercial premises or offices in a residential building.

---

#### Second Environment

An environment that includes industrial premises and establishments that are not connected directly to a public low-voltage power supply network.

---

**Note**

For example: industrial and technical areas of buildings fed from a dedicated transformer.

---

#### Category C1

Power Drive System (PDS) of rated voltage less than 1000 V intended for use in the First (Domestic) Environment.

#### Category C2

Power Drive System (PDS) of rated voltage less than 1000 V, which is neither a plug in device nor a movable device, and when used in the First (Domestic) Environment, is only intended to be installed and commissioned by a professional.

---

**Note**

A professional is a person or an organization having necessary skills in installing and/or commissioning a Power Drive System (PDS), including their EMC aspects.

---

## A.3 EMC Overall Performance

### EMC Emissions

The SINAMICS G120 drives have been tested in accordance with the emission requirements of the category C2 (domestic) environment.

Table A-1 Conducted & Radiated Emissions

EMC Phenomenon	Standard	Level
Conducted Emissions	EN 55011	Class A
Radiated Emissions	EN 55011	Class A

#### Note

To achieve this performance the default switching frequency should not be exceeded.

In order to achieve conducted emissions to EN 55011 Class B there is a range of PM240 external filter options available.

Achieving radiated emissions to EN 55011 Class B is largely dependent on the drive being correctly installed inside a metallic enclosure. The limits will not be met if the drive is not enclosed or installed in accordance with good EMC practices.

### Harmonic Currents

The harmonic current emissions from the SINAMICS G120 drives is as follows:

Table A-2 Harmonic Currents

Rating	Typical Harmonic Current (% of rated input current)							
	5th	7th	11th	13th	17th	19th	23rd	25th
FSA ... FSF (400 V, 370 W ... 110 kW)	73	52	25	23	22	15	12	10

#### Note

Units installed within the category C2 (domestic) environment require connection to the public low-voltage power supply network. Please contact your local supply network provider.

Units installed within the category C3 (industrial) environment do not require connection approval.

### EMC Immunity

The SINAMICS G120 drives have been tested in accordance with the immunity requirements of category C3 (industrial) environment:

Table A-3 EMC Immunity

EMC Phenomenon	Standard	Level	Performance Criterion
Electrostatic Discharge (ESD)	EN 61000-4-2	4 kV Contact discharge	A
		8 kV Air discharge	
Radio-frequency Electromagnetic Field	EN 61000-4-3	80 MHz ... 1000 MHz 10 V/m	A
Amplitude modulated		80% AM at 1 kHz	
Fast Transient Bursts	EN 61000-4-4	2 kV @ 5 kHz	A
Surge Voltage	EN 61000-4-5	1 kV differential (L-L)	A
1.2/50 $\mu$ s		2 kV common (L-E)	
Conducted	EN 61000-4-6	0.15 MHz ... 80 MHz 10 V/rms	A
Radio-frequency Common Mode		80% AM at 1 kHz	
Mains Interruptions & Voltage Dips	EN 61000-4-11	100% dip for 3 ms	A
		30% dip for 10 ms	B
		60% dip for 100 ms	C
		95% dip for 5000 ms	D
Voltage Distortion	EN 61000-2-4 Class 3	10% THD	A
Voltage Unbalance	EN 61000-2-4 Class 3	3% Negative Phase Sequence	A
Frequency Variation	EN 61000-2-4 Class 3	Nominal 50 Hz or 60 Hz ( $\pm$ 4%)	A
Commutation Notches	EN 60146-1-1 Class B	Depth = 40%	A
		Area = 250% x degrees	

**Note**

The immunity requirements apply equally to both filtered and unfiltered units.

## A.4 Standards ((PM240))

### Standards



#### European Low Voltage Directive

The SINAMICS G120 product range complies with the requirements of the Low Voltage Directive 2006/95/EC. The units are certified for compliance with the following standards:

EN 61800-5-1 — Semiconductor inverters –General requirements and line commutated inverters

EN 60204-1 — Safety of machinery –Electrical equipment of machines

---

#### European Machinery Directive

The SINAMICS G120 inverter series does not fall under the scope of the Machinery Directive. However, the products have been fully evaluated for compliance with the essential Health & Safety requirements of the directive when used in a typical machine application. A Declaration of Incorporation is available on request.

---

#### European EMC Directive

When installed according to the recommendations described in this manual, the SINAMICS G120 fulfils all requirements of the EMC Directive as defined by the EMC Product Standard for Power Drive Systems EN 61800-3

---



#### Underwriters Laboratories

UL and CUL LISTED POWER CONVERSION EQUIPMENT for use in a pollution degree 2 environment.

Note: UL certification is presently in progress.

---

#### ISO 9001

Siemens plc operates a quality management system, which complies with the requirements of ISO 9001.

---

Certificates can be downloaded from the internet under the following link:  
<http://support.automation.siemens.com/WW/view/de/22339653/134200>



# B

## List of abbreviations

### B.1 Abbreviations

#### Abbreviations

Table B-1 Abbreviations

Abbreviations	State
<b>A</b>	
AC	Alternating Current
A/D	Analog digital converter
ADR	Address
AFM	Additional frequency modification
AG	Automation Unit
AI	Analog input
AK	Request Identifier
AO	Analog output
AOP	Advanced operation panel
ASIC	Application-specific integrated circuit
ASP	Analog setpoint
ASVM	Asymmetric space vector modulation
<b>B</b>	
BCC	Block check character
BCD	Binary-coded decimal code
BI	Binector input
BIA	Berufsgenossenschaftliches Institut für Arbeitssicherheit
BICO	Binector/connector
BO	Binector output
BOP	Basic Operator Panel
<b>C</b>	
C	Commissioning
CB	Communication board
CCW	Counter-clockwise
CDS	Command data set
CE	Communauté Européenne
CI	Connector input

List of abbreviations

B.1 Abbreviations

Abbreviations	State
CM	Configuration management
CMD	Command
CO	Connector output
CO/BO	Connector output/Binector output
COM	Common (terminal is connected to NO or NC)
CT	Commissioning, ready to run
CU	Control Unit
CUT	Commissioning, run, ready to run
CW	Clockwise
<b>D</b>	
DAP	Device Access Point
D/A	Digital analog converter
DC	Direct current
DDS	Drive data set
DI	Digital input
DIP	DIP switch
DO	Digital output
DP	Distributed I/Os
DP-V1	Acyclic data transfer (extended PROFIBUS function)
DS	Drive state
<b>E</b>	
ECD	Equivalent circuit diagram
EEC	European Economic Community
EEPROM	Electrical erasable programmable read-only memory
ELCB	Earth leakage circuit breaker
EMC	Electromagnetic compatibility
EMF	Electromagnetic force
ES	Engineering System
FAQ	Frequently asked question
<b>F</b>	
Fast FFB	Fast freely programmable function blocks
FB	Function block
FCC	Flux current control
FCL	Fast current limiting
FF	Fixed frequency
FFB	Freely programmable function blocks
FOC	Field orientated control
FREQ	Frequency
FSA	Frame size A
FSB	Frame size B
FSC	Frame size C
FSD	Frame size D

Abbreviations	State
FSE	Frame size E
FSF	Frame size F
<b>G</b>	
GSD	Device Data File (Geräte Stamm Datei)
GSG	Getting Started Guide
GUI ID	Global unique identifier
<b>H</b>	
HIW	Main actual value
HMI	Human machine interface
HO	High Overload (Constant Torque)
HSW	Main setpoint
HTL	High-voltage transistor logic
<b>I</b>	
I/O	In-/output
IBN	Commissioning
IGBT	Insulated gate bipolar transistor
IND	Sub-index
<b>J</b>	
JOG	JOG
<b>K</b>	
KIB	Kinetic buffering
<b>L</b>	
LCD	Liquid crystal display
LED	Light emitting diode
LGE	Length
LO	Light Overload (Variable Torque)
LWL	Fiber Optic conductor
<b>M</b>	
MHB	Motor holding brake
MLP	Multi-Language Pack
MOP	Motor operated potentiometer
MMC	Micro Memory Card
<b>N</b>	
NC	Normally closed
NEMA	National Electrical Manufacturers Association
NO	Normally open
<b>O</b>	
OLM	Optical Link Module
OLP	Optical Link Plug
OM	Object Manager
OPI	Operating Instructions
<b>P</b>	

List of abbreviations

B.1 Abbreviations

Abbreviations	State
PAP	Parameter Access Point
PID	Proportional, integral, derivative controller
PKE	Parameter ID
PKW	Parameter channel (Parameter/Kennung/Wert)
PLC	Programmable logic control
PM	Power module
PM-IF	Power module interface
PNU	Parameter Number
PNO	PROFIBUS Nutzerorganisation
PPO	Parameter process data object
PTC	Positive temperature coefficient
PWE	Parameter value
PWM	Pulse-width modulation
Pxxxx	Write parameter
PZD	Process data area (Prozeßdaten)
<b>Q</b>	
QC	Quick commissioning
<b>R</b>	
RAM	Random-access memory
RCCB	Residual current circuit breaker
RCD	Residual current device
RFG	Ramp-function generator
RFI	Radio frequency interference
ROM	Read-only memory
RPM	Revolutions per minute
rxxxx	read-only parameters of analogue signals
<b>S</b>	
SBC	Safe Break Control
SLVC	Sensorless vector control
SLS	Safe-Limited Speed
SOL	Serial option link
SS1	Safe Stop 1
STO	Safe Torque Off
STW	Control word
STX	Start of text
SVM	Space vector modulation
<b>T</b>	
TTL	Transistor-transistor logic
<b>U</b>	
USS	Universal serial interface
<b>V</b>	
V/f	Voltage/frequency

---

<b>Abbreviations</b>	<b>State</b>
VC	Vector control
VT	Variable torque
<b>W</b>	
WEA	Automatic restart
<b>Z</b>	
ZSW	Status word
ZUSW	Additional setpoint



# Index

## A

A&D Technical support, 95  
  America (Johnson City), 96  
  Asia/Pacific (Beijing), 96  
  Europe/Africa (Erlangen), 95  
  Online Service and support, 95

## B

BOP, 59

## C

Calculating the motor/control data, 45  
Changing parameters with the Basic Operator Panel, 38  
Classification of EMC performance, 101  
Commissioning functions, 15  
Commissioning the application, 48  
Common features, 14  
Control functions, 15  
Control Wiring, 25

## D

Download parameters, 59

## E

Electromagnetic compatibility, 100  
EMC Standards, 100  
European EMC Directive, 104  
European Low Voltage Directive, 104  
European Machinery Directive, 104

## F

Factory setting  
  Reset to, 58  
Fitting the Control Unit to the Power Module, 23

## I

ISO 9001, 104

## M

Monitoring parameters, 64  
Motor data identification, 44

## O

Operating functions, 15

## P

Parameter  
  Attributes, 64  
  Index, 65  
  upload, 33  
Parameter attribute  
  Access level, 65  
  Active, 68  
  BICO, 65  
  Can be changed, 66  
  Data type, 66  
  Grouping, 67  
  Quick commissioning, 68  
  Unit, 67  
  Value range, 68  
Parameter channel, 78  
Parameters  
  Data sets, 69  
Protective functions, 15

## R

Reset to the factory setting, 58

## S

Safety notes

- Commissioning, 11
- Dismantling and disposal, 12
- General Warnings, Cautions and Notices, 10
- Operation, 12
- Repair, 12
- Safety Instructions, 9
- Transport and storage, 11
- Self certification, 100
- SINAMICS G120 range, 13
- Standards, 104
- STARTER
  - Download, 62
- Status display, 90
- Swapping a CU, 71
- Swapping the PM, 72

## T

- Technical construction file, 100

## U

- Underwriters Laboratories, 104
- Universal Serial Interface, 73
- Upload parameter, 33
- Upload parameters, 59
- USS, 73





**Siemens AG**

Industry Sector  
Drive Technologies  
Standard Drives  
Postfach 32 69  
D-91050 Erlangen

[www.siemens.de/sinamics-g120](http://www.siemens.de/sinamics-g120)