

BDS4 SERIES

INSTALLATION AND SETUP MANUAL

Old Number M93100 - Issue 2

New Number MB4001H

THANK YOU!

KOLLMORGEN **Motion Technologies Group**

Thank you and congratulations for choosing Kollmorgen's servo products for your motion control requirements. We seek to provide our customers with quality products, excellent support and outstanding value. In an effort to provide you with dependable and useful documentation, we offer you an opportunity to critique this manual with your comments and suggestions. Your feedback on this reader comments form is very important to us. Please answer the questions below and return the form to:

Kollmorgen Motion Technologies Group - Technical Manual Department

201 Rock Road
Radford, VA 24141
U.S.A.
FAX: 540/731/0847

Name: _____ Title: _____
Company: _____
Street Address: _____
City: _____ State: _____ Zip: _____
Telephone: _____ Fax: _____
Product: _____
Manual Part Number: _____

Please check the rating that best represents your opinion on each topic.

		Excellent	Good	Fair	Poor
1.	Overall clarity and readability.	<input type="checkbox"/>	<input type="checkbox"/>	<input type="checkbox"/>	<input type="checkbox"/>
2.	Organization of the manual.	<input type="checkbox"/>	<input type="checkbox"/>	<input type="checkbox"/>	<input type="checkbox"/>
3.	Information completeness.	<input type="checkbox"/>	<input type="checkbox"/>	<input type="checkbox"/>	<input type="checkbox"/>
4.	Information accuracy.	<input type="checkbox"/>	<input type="checkbox"/>	<input type="checkbox"/>	<input type="checkbox"/>
5.	Installation procedures.	<input type="checkbox"/>	<input type="checkbox"/>	<input type="checkbox"/>	<input type="checkbox"/>
6.	Ability to quickly find information you need.	<input type="checkbox"/>	<input type="checkbox"/>	<input type="checkbox"/>	<input type="checkbox"/>
7.	Graphics.	<input type="checkbox"/>	<input type="checkbox"/>	<input type="checkbox"/>	<input type="checkbox"/>
8.	Figures (usefulness).	<input type="checkbox"/>	<input type="checkbox"/>	<input type="checkbox"/>	<input type="checkbox"/>
9.	Tables (usefulness).	<input type="checkbox"/>	<input type="checkbox"/>	<input type="checkbox"/>	<input type="checkbox"/>
10.	Overall rating of this manual.	<input type="checkbox"/>	<input type="checkbox"/>	<input type="checkbox"/>	<input type="checkbox"/>

Please list any errors. _____

What did you like least about this manual? _____

What did you like most about this manual? _____

How would you improve this manual? _____

Signature: _____ Date: _____

European Community (EC) Declaration of Conformity

We, Kollmorgen Corporation Industrial Drives Division, 201 Rock Road, Radford, Virginia USA; declare under sole responsibility that this equipment is exclusively designed for incorporation in another machine. The operation of this equipment is submitted to the conformity of the machine in which it is incorporated, following the provisions of the EC Electro-Magnetic Compatibility (EMC) directive 89/392/EEC.

© Copyright 1993, Danaher Motion Kollmorgen. All rights reserved
Printed in the United States of America

NOTICE

Not for use or disclosure outside of Danaher Motion Kollmorgen except under written agreement.

All rights reserved. No part of this book shall be reproduced, stored in a retrieval system, or transmitted by any means (electronic, mechanical, photocopying, recording, or otherwise) without the written permission from the publisher. While every precaution has been taken in the preparation of this book, the publisher assumes no responsibility for errors or omissions. Neither is any liability assumed for damage resulting from the use of the information contained herein.

This document is proprietary information of Danaher Motion Kollmorgen, furnished for customer use ONLY. No other uses are authorized without written permission from Danaher Motion Kollmorgen.

Information in this document is subject to change without notice and does not represent a commitment on the part of Danaher Motion Kollmorgen. Therefore, information contained in this manual may be updated without notice due to product improvements, etc., and may not conform in every respect to former issues.

This product is covered by U. S. Patents:

4,447,771

4,479,078

4,490,661

Other (foreign patents pending)

U. L. is a trademark of Underwriter's Laboratories.

N. E. C. is a trademark of the National Electric Code.

Kollmorgen **GOLDLine**, BDS4, BDS5, and PSR4/5 are trademarks of Danaher Motion Kollmorgen.



Dangerous voltages, currents, temperatures, and energy levels exist in this product and in the associated servomotor(s). Extreme caution should be exercised in the application of this equipment. Only qualified individuals should attempt to install, setup, and operate this equipment. Ensure that the motor, drive, and the end-user assembly are all properly grounded per NEC requirements.

KOLLMORGEN
Motion Technologies Group

Danaher Motion Kollmorgen

Phone: 1-800-777-3786 or (815) 226-3100
Technical Support Fax: (540) 731-5679

FOREWORD

The commitment to quality at Industrial Drives is our first priority. In all aspects of our business: research, development, product design and customer service, we strive to guarantee total quality. This pledge is founded on a solid history of innovative technological achievements dating back to 1948. One of the finest tributes to that achievement can now be seen at the Smithsonian which has on display the first stellar inertial navigation system developed by Dr. Charles Stark Draper. This system contains the first models of torque motors built by the founding organization of Industrial Drives. During the period of 1948 to 1960, our "firsts" in the industry numbered more than a dozen; they ranged from the simple but invaluable (such as the direct-drive DC torque motor and movie theater projection motors) to the exotic: submarine periscope drive motors for the U.S. Navy, electric drives, Curtis Wright electric brake coils, and numerous other innovations.

For more than a decade, Industrial Drives (known in the early days as part of Inland Motor Division of Kollmorgen) has continued to enhance its sophisticated engineering solutions to pioneer new product development.

The results of these and other efforts has encouraged some of the most significant innovations in the servo industry. We developed the application of servo motors and drives in the Machine Tool market. We were the first with water-cooled servos, the integral brake, the flux forcing concept and the brushless motor. We developed the electronically commutated electric car motor. Industrial Drives pioneered rare

earth magnet development for the servo motor industry.

Between 1974 and 1980, Industrial Drives continued to lead the industry in servo application innovations. Our commitment to engineering excellence never wavered. In fact, that commitment grew stronger with the development of brushless submarine and submersible motors (visiting the Titanic graveyard), multi-axis electronic drives and antenna pedestal drives (delivering unprecedented accuracy and revolutionizing the entire industrial automation process).

The decade of the 1980's brought continued advancements in technology and penetration of new markets requiring precise motion control. Already in the fifth generation of brushless products, Industrial Drives continues to lead the way with digital servo positioning capability and our newest motor offering, the GOLDLINE Series, incorporating the very latest high-energy, rare earth magnets (neodymium iron boron). Once again, we are setting the standards that others only hope to duplicate. Recently acknowledged by the Frost and Sullivan Foundation, a leading market specialist in the motion control industry, Industrial Drives and its parent, Kollmorgen Corporation, continue to rank first in servo technology.

Other achievements? Yes, too many in fact to mention. Each achievement stands as a testimony to the committed quality and excellence in design technology. This constancy of purpose is unyielding in an era of rapidly changing technology.

TABLE OF CONTENTS

CHAPTER 1. SYSTEM DESCRIPTION	
1.1 Introduction	1-1
1.2 Product Description	1-1
1.3 Features	1-1
1.4 Theory of Operation	1-2
1.4.1 PSR4/5 Power Supply Module	1-2
1.4.2 BDS4 Servo Amplifier Module	1-4
1.4.3 Brushless DC Motor	1-5
1.4.4 Power Up/Down Sequencing	1-5
1.4.5 With Soft-Start Circuit (Standard)	1-5
1.4.6 Without Soft-Start Circuit or Dynamic Bus Discharge (Optional)	1-6
1.5 Typical System Diagram	1-6
CHAPTER 2. INSTALLATION	
2.1 Introduction	2-1
2.2 Safety information	2-1
2.3 Conventions	2-1
2.3.1 BDS4A vs. BDS4V & PSR4/5A vs. PSR4/5V	2-2
2.3.2 Model Numbering Scheme	2-2
2.3.3 Abbreviations	2-2
2.4 Unpacking And Inspection	2-2
2.5 Installation Requirements	2-2
2.5.1 Environmental Considerations	2-3
2.5.2 Enclosures	2-3
2.6 Assembly	2-3
2.6.1 Mounting	2-3
2.6.2 Mounting the External Regeneration Resistor(s)	2-4
2.7 Electrical Connections	2-4
2.7.1 Recommended Torque for Electrical Connections	2-5
2.7.2 Grounding Scheme	2-5
2.7.3 Connecting the AC Input Voltages	2-6
2.7.4 Connecting the PSR4/5 Fault Output Contact (Connector C1)	2-6
2.7.5 Connecting the Unregulated DC Voltage to the BDS4 (Connector C3)	2-6
2.7.6 Connecting the Main DC Bus Voltage	2-6
2.7.7 Connecting the External Regeneration Resistor(s)	2-6
2.7.8 Connecting the BDS4 Input/Output (Connector C1)	2-8
2.7.9 Connecting the Motor	2-10
2.8 Installation Checklist	2-10
2.8.1 Checking the Motor and Resolver Wiring	2-11
2.8.2 Checking the AC Line Voltages	2-11
2.8.3 Checking the DC Bus Voltages	2-12
CHAPTER 3. OPERATION	
3.1 Introduction	3-1
3.2 Initial START-UP	3-1
3.3 Sequence of Operations	3-1
CHAPTER 4. MAINTENANCE	
4.1 Introduction	4-1
4.2 Preventative Maintenance	4-1
4.2.1 Transient Voltages	4-1
4.2.2 Surge Current	4-1
4.2.3 Electrical Noise	4-2
4.2.4 Radio Frequency Energy	4-2
4.3 Periodic Maintenance	4-2
4.3.1 Ventilation	4-2
4.3.2 Grounding Integrity	4-2
4.4 Adjustments	4-3
4.4.1 Set-Up Adjustments	4-3
4.4.1.1 Balance Adjustment (Within Position Loop)	4-3
4.4.1.2 Balance Adjustment (Automatic or Manually Operated Machines)	4-3
4.4.1.3 Command Scale Adjustment (Within Position Loop)	4-3
4.4.1.4 Command Scale Adjustment (Automatic or Manually Operated Machines)	4-3
4.4.2 Response and Application Dependent Adjustments	4-3
4.4.2.1 Stability Adjustment	4-4
4.4.2.2 Current Limit Adjustment	4-4
4.4.3 Design Tolerance Adjustments	4-4
4.4.3.1 Resolver Excitation Adjustment	4-4
4.4.3.2 Current Sensor Offset Adjustments	4-4
4.4.3.3 Motor System Resolver Alignment	4-4
4.4.3.4 Factory Only Adjustments	4-6
CHAPTER 5. TROUBLESHOOTING	
5.1 Introduction	5-1
5.2 Field Serviceability	5-1

5.3 Symptoms and Corrections.....	5-2
5.3.1 The Motor Exhibits Very Low Torque or is Totally Inoperative	5-2
5.3.2 The Motor is Erratic or Exhibits an Improper Mode of Operation.	5-2
5.3.3 BDS4-3, 6, 10, 20, 30, 40 and 55 Amp Status LED'S	5-2
5.3.4 PSR4/5-12 and 20 Amp Status LED's.....	5-3
5.3.5 PSR4/5-50 and 75 Amp Status LED's.....	5-4
5.3.6 BDS4 or PSR4/5 Reset Procedures	5-4

CHAPTER 6. SPARE PARTS

6.1 Introduction	6-1
6.2 Recommended Spare Parts	6-1
6.3 Ordering instructions	6-3

APPENDIX A. WARRANTY INFORMATION

APPENDIX B. MODEL NUMBERS

APPENDIX C. CONNECTOR KITS & TOOLS

APPENDIX D. SPECIFICATIONS

APPENDIX E. OPTIONS

E.1 PSR4/5 Electrical Options.....	E-1
E.2 BDS4 Electrical Options	E-1
E.2.1 Integrated Options.....	E-1
E.2.2 BDS4 OPT2/3A Option Board	E-1
E.2.2.1 BDS4-OPT2/3A-01 Board.....	E-2
E.2.2.2 BDS4-OPT2/3A-02 Board.....	E-3
E.2.2.3 BDS4-OPT2/3A-03 Board.....	E-3
E.2.2.4 BDS4 and BDS4-OPT2/3A (Board) System Specifications	E-3
E.3 BDS4-OPT-D/L Option Board	E-4

APPENDIX F. DRAWINGS

LIST OF FIGURES

FIGURE	PAGE	FIGURE	PAGE
1.1 BDS4 and PSR4/5 (Low current models).....	1-3	2.6 Motor Resolver Connections	2-11
1.2 Typical System Diagram	1-7	2.7 Armature Motor Connections.....	2-12
2.1 Safety-Alert Symbols	2-1	5.1 BDS4 Status LED's.....	5-3
2.2 PSR4/5 (C1).....	2-7	5.2 PSR4/5 12, 20 Amp Status LED's	5-4
2.3 BDS4 (C3) & PSR4/5 (C2).....	2-7	5.3 PSR4/5 50, 75 Amp Status LED's	5-4
2.4 BDS4 Connector (C1)	2-8	E.1 Connector 32.....	E-2
2.5 BDS4 (C2)	2-10	E.2 Encoder Output Timing	E-9

LIST OF TABLES

<u>TABLE</u>	<u>PAGE</u>	<u>TABLE</u>	<u>PAGE</u>
2.1 Torque Values.....	2-5	B.7 Cable Model Number Scheme for Individual Cable (Bayonet-Type Thread).....	B-7
2.2 BDS4 Unregulated DC Voltages (C3)	2-7	B.8 Cable Model Number Scheme for Individual Cable (Screw-Type Thread)	B-8
5.1 Improper Motor Operation Troubleshooting..	5-5	B.9 Resolver Feedback Cables	B-9
5.2 BDS4 Status LED Indicator Troubleshooting	5-6	B.10 Bus Bars	B-10
5.3 PSR4/5 12 & 20 Amp Status LED Indicator Troubleshooting	5-7	C.1 Connector Kit BDS4C-100	C-1
5.4 PSR4/5 50 & 75 Amp Status LED Troubleshooting.....	5-7	C.2 Connector Kit BDS4C-101	C-2
6.1 BDS4 Spare Parts List.....	6-1	C.3 Connector Kit BDS4C-200	C-2
6.2 PSR4/5 Spare Parts List	6-2	C.4 Connector Kit PSR4/5C-200.....	C-3
B.1 PSR4/5 Model Number Scheme.....	B-1	C.5 Connector Tools.....	C-3
B.2 ER-External Resistor Kit Model Number Scheme	B-2	D.1 PSR4/5 Specifications.....	D-2
B.3 BDS4 Model Number Scheme	B-3	D.2 BDS4 Specifications	D-5
B.4 Compensation Model Number Designator ...	B-4	D.3 Derating Data	D-9
B.5 Cable Model Number Scheme for Individual Cable Set (Bayonet-Type Thread).....	B-5	D.4 Environmental Specifications	D-10
B.6 Cable Model Number Scheme for Individual Cable Set (Screw-Type Thread)...	B-5	D.5 Mechanical Specifications	D-10
		E.1 BDS4-OPT2/3A-01 Board Specifications	E-5
		E.2 OPT2/3A-02 and OPT2/3A-03 Pinouts	E-6
		E.3 System Specifications.....	E-7
		E.4 R\D Converter Speeds	E-8

List of Drawings

A-63542.....	Motor Connection
A-83908.....	Purchase Spec. for Mini-Fit, Jr.Series Connector
A-83909.....	Purchase Spec. for Mini-Fit, Jr.Series Terminals
A-84385.....	Outline & Dimension PSR4/5 - 12 & 20 Amp
A-93031.....	Outline & Dimension PSR4/5 - 50 & 75 Amp
A-93092.....	PRS4/5 50A / 75A (with & without Soft Start) Simplified Schematic
A-93112.....	Outline & Dimension BDS4 - 55 Amp
A-93141.....	Wiring & Mounting DiagramER-20
A-93156.....	Outline & Dimension BDS4 - 30 & 40 Amp
A-93231.....	BDS4 Wiring Diagram
A-93314.....	Wiring & Mounting Diagram ER-21
A-93315.....	Wiring & Mounting Diagram ER-22
A-93316.....	Wiring & Mounting Diagram ER-23
A-93369.....	GOLDLINE Amplifier Assembly Guide for Resolver Cables
A-93408.....	PRS4/5 12A / 20A Simplified Schematic
A-93409.....	PSR4/5 Internal Schematic
A-93414.....	GOLDLINE Amplifier Assembly Guide for Motor Cables (30, 40, & 55 Amp)
A-93421.....	GOLDLINE Amplifier Assembly Guide for Motor Cables (3 thru 20 Amp)
A-93538.....	GOLDLINE Amplifier Assembly Guide for Motor Cables (3 thru 20 Amp)
A-93539.....	GOLDLINE Amplifier Assembly Guide for Motor Cables (30, 40, & 55 Amp)
A-93540.....	GOLDLINE Amplifier Assembly Guide for Resolver Cables
A-93541.....	BDS4 Direction Limit Wiring Diagram
A-93567.....	Outline & Dimension BDS4 - 3 & 6 Amp
A-93568.....	Outline & Dimension BDS4 - 20 Amp
A-93572.....	Outline and Dimension BDS4 - 10 Amp
A-93656.....	Mounting Hole Pattern BDS4, BDS5, PSR4/5
A-93700.....	DC Bus Cable Assembly for BDS4/5 & PSR4/5
A-93703.....	Mounting Hole Pattern BDS4
B-84929.....	BDS4 & BDS5 Logic Cable Assembly
C-84113.....	BDS4 Simplified Schematic
C-84723.....	PSR4/5 Simplified Schematic
C-84724.....	PSR4/5 Internal Schematic
C-93185.....	BDS4 - OPT2/3A Pinout Options
D-93179.....	BDS4 - OPT2/3A

CHAPTER 1

SYSTEM DESCRIPTION

1.1 INTRODUCTION

The information in this chapter will enable you to understand the product's basic functions and features. These concepts will allow you to apply them to your own unique applications.

1.2 PRODUCT DESCRIPTION

Industrial Drives' BDS4 product lines are 3-phase sine wave, brushless motor controllers. They are fully regenerative four-quadrant, bi-directional velocity loop amplifiers designed to be used with Industrial Drives' high performance B series permanent magnet brushless motors.

Although the BDS4 is basically an analog servo amplifier, it contains a microprocessor to implement Industrial Drives' patented Torque Angle Control function for maximum system performance.

The BDS4 amplifier modules are available in sizes of 3, 6, 10, 20, 30, 40 and 55 amps RMS/phase continuous. The modular design provides the flexibility for multiple axes to share a common power supply requiring no input isolation transformer.

The PSR4/5 Power Supply modules are available in sizes of 12, 20, 50 and 75 amps RMS/phase continuous (AC input line ratings).

Numerous Industrial Drives B Series motors with various diameters, stack lengths, and windings are also available.

1.3 FEATURES

Highlighted design features are:

- Modular construction maximizing serviceability.
- Two-part plug connectors interfacing between the BDS4, PSR4/5, and other equipment.
- Routine adjustments accessible from the front of the BDS4.
- High frequency (20 kHz) motor current ripple for quality servo performance, higher efficiency, and less audible noise.
- Differential velocity or current command input.
- Voltage programmable current limit input.
- A removable compensation board containing all the components that make the BDS4 compatible with a particular motor.
- Protection against thermal overload indicates any overtemperature conditions. The BDS4 is protected against peak current overloads by a current foldback circuit. Also, it is protected

from logic bus out-of-tolerance conditions and motor stator short circuit conditions, both line-to-line and line-to-ground.

- Drive-Up contact closes indicating the amplifier is ready for input command signal; opens on fault conditions.
- Standard PSR4/5 Power Supply units contain a Soft Start function and a dynamic bus discharge function.
- The 12 and 20 amp PSR4/5 units have, as standard, 40 watts of internal shunt regulation. There are optional versions available having no shunt regulator. Other options have externally mounted power resistance allowing shunt regulation of up to 700 watts. The shunt regulator is protected from excessive peak current by fuse. It is also protected from excessive duty, if duty cycle exceeds a preset limit, by shunt overload shutdown circuit.
- The 50 and 75 amp PSR4/5 shunt regulation is accomplished with externally mounted power resistor(s) with ratings from 500 to 2000 watts as standard. Special units may be ordered for even higher power. The shunt regulator is protected from excessive peak current by a thermal overload relay. It is also protected from excessive duty, if duty cycle exceeds a preset limit, by shunt overload shutdown circuit.
- Diagnostic LED indicators located on the front panel on both the BDS4 and the PSR4/5 modules.
- Either a 12-Bit Parallel Position Information Card or an Encoder Equivalent Output Card as available options.

1.4 THEORY OF OPERATION

The BDS4 brushless servo system consists of three main components:

1. PSR4/5 - Power Supply Module
2. BDS4 - Amplifier Module
3. B - Brushless Motor

All of the compensation components necessary to match a BDS4 amplifier to a particular motor such as, current loop compensation, velocity loop compensation, and torque angle compensation, are located on the removable BDS4 COMP compensation board located inside the BDS4 amplifier.

The TL (Test Limits and Modification) Sheet contains the compensation component values and such information as maximum operating speed, peak current limits, etc. that are assigned to each BDS4 system.

Only motors having the identical base model number may be run on the BDS4 amplifiers. If a motor having a different base motor model number is to be run on a BDS4, the BDS4-COMP compensation board must be altered or changed accordingly. The BDS4 must remain the same current and voltage rating.

1.4.1 PSR4/5 Power Supply Module

Refer to Figure 1.1 for a quick reference of the PSR4/5 and drawings A-93409, A-93408 and A-93092 for precise details.

The PSR4/5 Power Supply Module is divided into four (4) main sections:

1. The Unregulated Logic Bus, supplied by the Control AC line input voltage (normally single-phase 115 VAC), is described in Section 4.2.
2. The 310/140 Main DC Bus is supplied by the main AC line input voltage (normally three-phase 230 VAC or single-phase 115 VAC).
3. The Soft-Start Feature (standard) resistor limits the inrush current (to charge-up the Main Bus Capacitors) to a specific amount as listed in Appendix D.
4. The Shunt Regulator (regeneration) section includes circuitry which monitors the main bus. During deceleration profiles, the motor basically operates as a DC generator and pumps energy back into the main bus causing the bus to rise. The Shunt Regulator

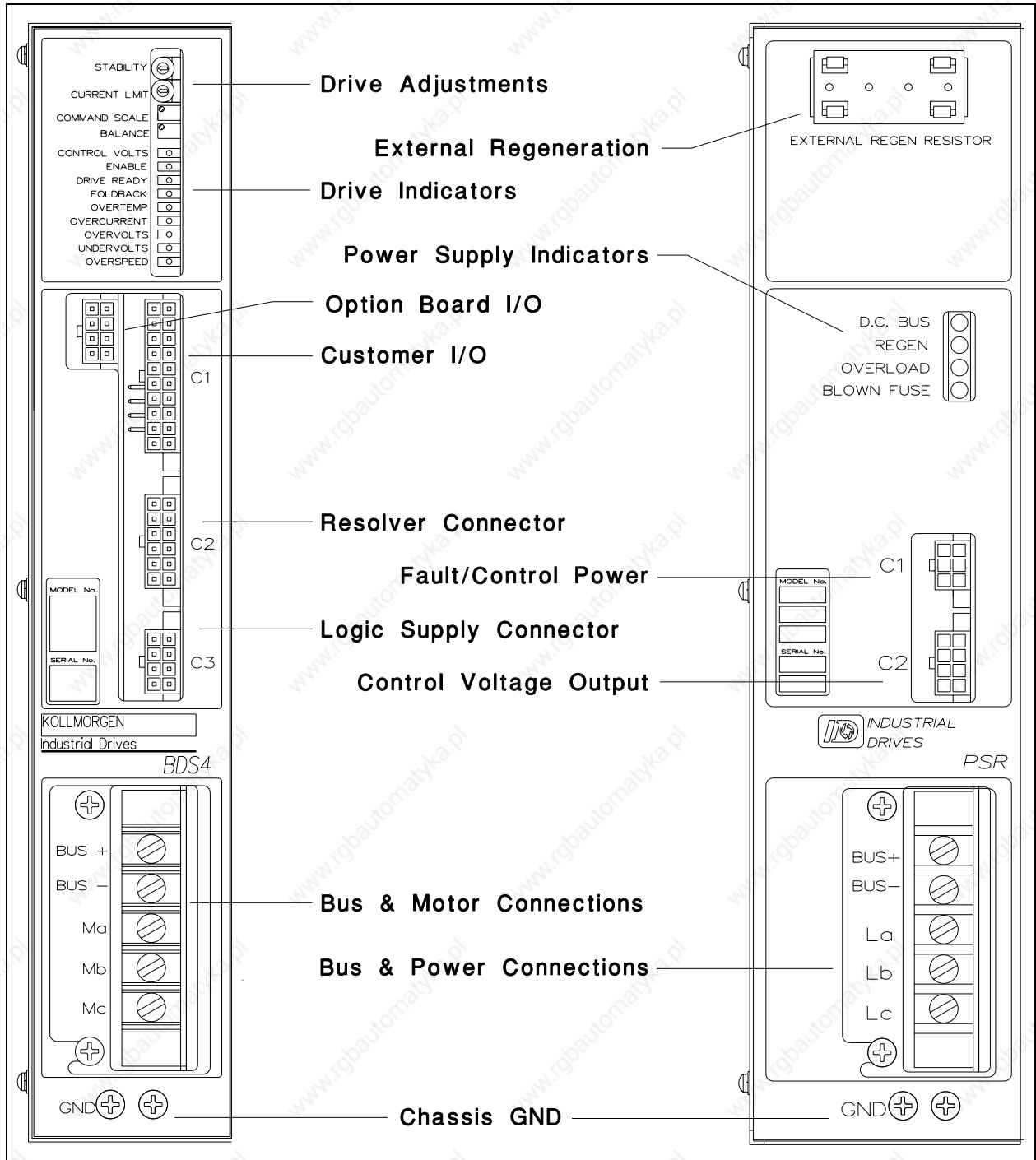

Figure 1.1. BDS4 and PSR4/5 (Low Current Models shown)

limits the voltage rise during the deceleration periods.

- 12 and 20 AMP Models:

The shunt regulator (regeneration) resistor load is fuse protected. If the shunt regulator

is held on for too long, the shunt regulator power transistor fails, or the shunt regulator load resistor becomes shorted, the fuse will blow and cause the Fault Contact on the PSR4/5 to open and the BLOWN REGEN FUSE LED to become illuminated.

The shunt regulator also includes a duty cycle limit circuit to protect against excessive load resistor heating. If the average duty cycle limit is exceeded, the regeneration circuitry will become disabled, the Fault Contact will open, and the OVERLOAD LED will become illuminated. To reset this fault, remove and reapply all input line power; bus capacitors must completely discharge.

- 50 and 75 AMP Models:



WARNING

The thermal overload output contacts must be connected into a shut down circuit (E Stop string, etc.) to drop the main power or a possible fire hazard will exist. Refer to Drawing A-93231.

The shunt regulator (regeneration) resistor is protected by a thermal overload relay. If the resistor rating is exceeded or if the shunt regulator transistor fails, the thermal overload output contacts will open indicating an IMMEDIATE need to remove the main power.

1.4.2 BDS4 Servo Amplifier Module

Refer to Figure 1.1 for a quick reference of the BDS4's features.

The BDS4 Servo Amplifier is divided into four (4) main sections:

1. **Fault Diagnostics** monitor various signal leads. When a fault condition occurs the fault circuit will become latched, the BDS4 will become internally inhibited, the appropriate red LED will become illuminated, and the Drive-Up contact will open indicating that the BDS4 is in its Inhibit mode.
2. The Input/Output interface circuitry is divided into two functions:

(A) Signals to and from the motor and BDS4.

These signals are associated with the motor system resolver. A 7.0 kHz excitation signal is generated in the BDS4 and sent to the resolver. Two resolver feedback signals (sine and cosine) are received by the BDS4 and processed by an R/D (resolver-to-digital) converter. The R/D unit generates a digital position word used in electronically commutating the motor and an analog velocity (internal tach) signal to close the servo loop.

(B) Signals to and from the signal source (PLC, CNC, etc.) and BDS4.

There are numerous signals that may interface between the signal source (PLC, CNC, etc.) and the BDS4. These inputs and modes of operation differ with each application.

3. The BDS4 consists of a single velocity loop and three inner current loops. To give precise velocity control, the velocity loop is normally configured as a proportional, plus an integral, plus a derivative gain servo loop. The output of the velocity loop is the current command for the three microprocessor-based current loops.

The heart of the BDS4 is its microprocessor which receives and processes the current command (velocity error) signal from the output of the velocity loop circuit, the position information from the resolver-to-digital converter, and several other signals. After receiving the velocity error, the microprocessor generates three sinusoidal current commands. These current commands are forwarded to the three proportional plus integral current loops, one for each of the three motor phases.

The microprocessor is the key element in the Industrial Drives patented torque angle technique. The microprocessor varies the phase of the currents with respect to motor

flux and significantly improves the motor speed-vs-torque profile.¹

4. The outputs from the three current loop circuits are converted into a 10 kHz pulse width modulation scheme. The modulation is such that the 10 kHz PWM results in 20 kHz current ripple in the motor, resulting in very quiet motor operation.

The PWM switching signals are optically coupled to the power stage gate drive hardware for complete electrical isolation. The BDS4 uses IGBT's (Isolated Gate Bipolar Transistors) for the output power stage; allowing high frequency operation.

1.4.3 Brushless DC Motor

The Industrial Drives' B Series brushless motors feature the latest in permanent magnet technology, utilizing high energy Neodymium-Iron-Boron alloys. These brushless motors consist of permanent magnet rotors and three-phase Y-stator windings. This places the heat producing member on the outside where it can best dissipate heat. These motors (depending on size) are either four- or six-pole motors. Since they are brushless motors, there are no commutators or associated brushes. The motors run as synchronous motors, meaning the rotor speed is the same as the speed (frequency) of the stator's rotating magnetic field. The feedback device is a brushless resolver, mounted internally as part of the overall motor construction. Another available option is the integral brush tachometer. For more information, refer to the Installation and Service Manual, B Series Brushless Motors M-89031.

1.4.4 Power Up/Down Sequencing

First, apply the 115 VAC control voltage. Second, apply the main AC voltage. Third, check for faults and then enable the BDS4. The AC line input voltages may be removed in any sequence.

¹ The BDS4A/V sine-wave controller allows a wider range speed because it has the ability to electronically change the angle between the rotor flux and the stator flux—commonly referred to as torque angle. Industrial Drives, A Kollmorgen Division, Patented Numbers 4,447,771; 4,479,078; and 4,490,661.

1.4.5 With Soft-Start Circuit (Standard)

1. Only the Control AC line input voltage is applied.
 - a. The logic bus comes up.
 - b. A power-up reset pulse is generated in the BDS4.
 - c. If no faults (other than main bus undervolts) are present after the power-up reset pulse is generated (a delay of one second) then the drive is ready to be enabled. However, there can be no motor movement until the main AC line input voltage is applied.
2. The Main AC line input voltage is applied.
 - a. The soft-start circuit charges the Main DC bus capacitors in the PSR4/5 through a current limiting resistor.
 - b. The shunt regulator regeneration circuitry is switched from dynamic bus discharge to regular mode.
 - c. The undervoltage fault in the BDS4 is now cleared (after approximately 3/4 sec. delay), and if jumper J21 is installed on the BDS4-COMP Board, the Drive Ready LED will become illuminated and the Drive-Up contact in the BDS4 (between Pins 10 and 20 of Connector C1) will close. The BDS4 is ready to be enabled and will enable once the enable input is activated.
3. Only the Main AC line input voltage is removed.
 - a. Approximately 30 msec. after the Main AC line input voltage is removed, the shunt regulator is switched from regulate to the dynamic bus discharge mode, and the main DC bus power is discharged.
 - b. The shunt regulator circuit is deactivated.

- c. The Drive-Up contact within the BDS4 will open due to Bus undervolts.
4. Only the Control AC line input voltage is removed.
 - a. The Drive-Up contact in the BDS4 will open. The BDS4 is immediately disabled.
 - b. Operation of the soft-start/dynamic bus discharge and other circuits within the PSR4/5 will not be affected.
 - c. The PSR4/5 fault contact will open.

- b. The shunt regulator regeneration circuitry is switched from dynamic bus discharge to regular mode.

- c. The undervoltage fault in the BDS4 is now cleared (after approximately 3/4 sec. delay), and if jumper J21 is installed on the BDS4-COMP Board, the Drive Ready LED will become illuminated and the Drive-Up contact in the BDS4 (between Pins 10 and 20 of Connector C1) will close. The BDS4 is ready to be enabled and will enable once the enable input is activated.

3. Only the Main AC line input voltage is removed.

- a. The DC bus will bleed down slowly after approximately five minutes.
- b. The shunt regulator is deactivated.
- c. The Drive-Up contact within the BDS4 will open.

4. Only the Control AC line input voltage is removed.

- a. The BDS4 will be immediately disabled.
- b. The BDS4 Drive-Up contact will open.
- c. The PSR4/5 fault contact will open.

1.4.6 Without Soft-Start Circuit or Dynamic Bus Discharge (Optional)

1. Only the Control AC line input voltage is applied.
 - a. The logic bus comes up.
 - b. A power-up reset pulse is generated in the BDS4.
 - c. If no faults (other than main bus undervolts) are present after the power-up reset pulse is generated (a delay of one second) then the drive is ready to be enabled. However, there can be no motor movement until the main AC line input voltage is applied.
2. The Main AC line input voltage is applied.
 - a. The soft-start circuit charges the Main DC bus capacitors in the PSR4/5 through a current limiting resistor.

1.5 TYPICAL SYSTEM DIAGRAM

Figure 1.2 illustrates a typical system with all of the major components.

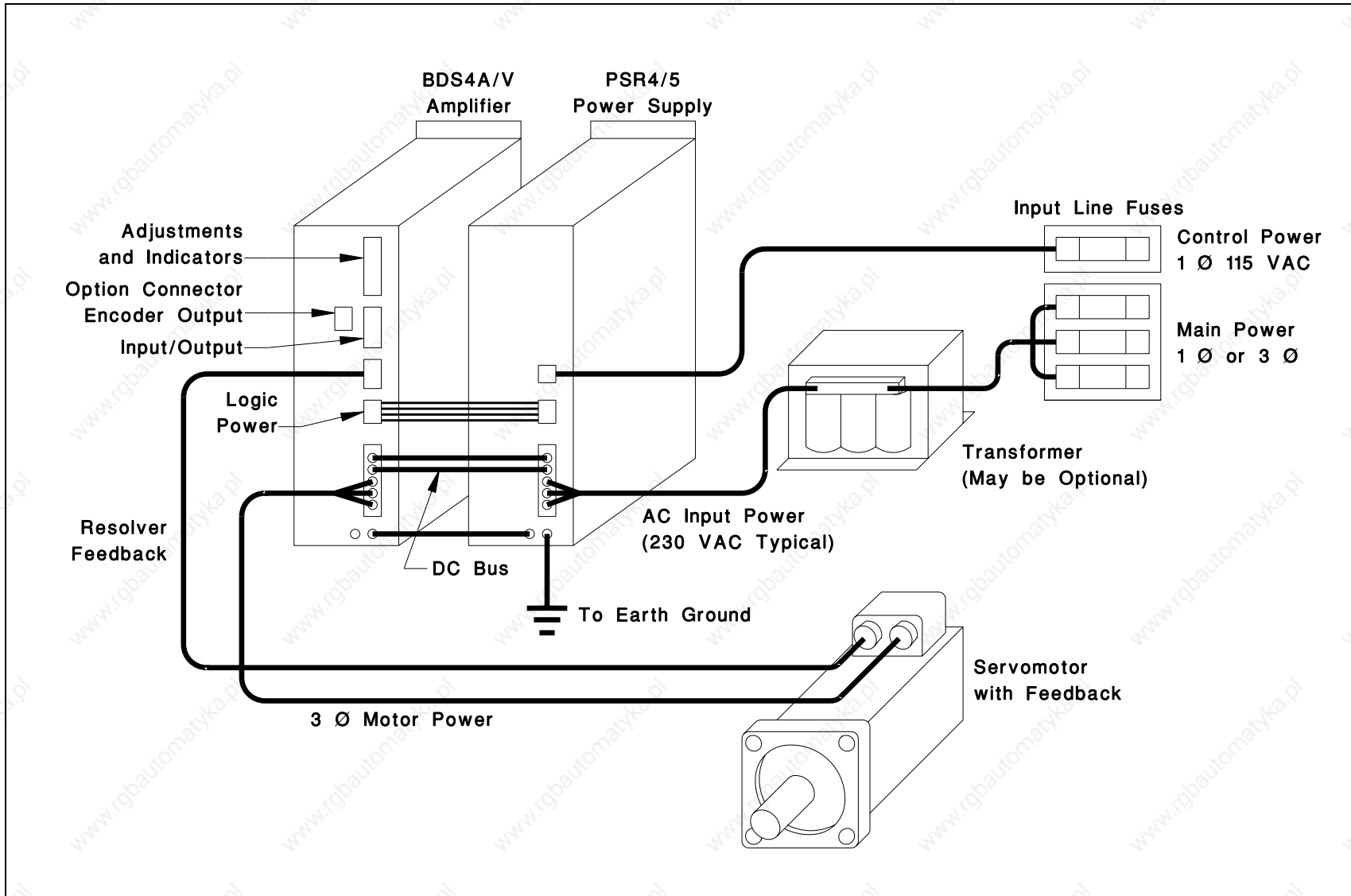

Figure 1.2. Typical System Diagram

CHAPTER 2

INSTALLATION

2.1 INTRODUCTION

The information in this chapter will familiarize you with the safety information, unpacking and inspection, installation requirements, assembly procedures and electrical connections for installing the BDS4. A checklist is provided at the end of this chapter to insure proper installation.

2.2 SAFETY INFORMATION

The purpose of this section is to alert you to possible safety hazards associated with this equipment and the precautions you can take to reduce the risk of personal injury and damage to the equipment.

Safety notices in this manual provide important information. Read and be familiar with these instructions before attempting installation, operation, or maintenance. Failure to observe these precautions could result in serious bodily injury, damage to the equipment, or operational difficulty.

The safety-alert symbols are illustrated in Figure 2.1. When you see these symbols in this manual, be alert



Figure 2.1. Safety-Alert Symbols

to the potential for personal injury. Follow the recommended precautions and safe operating practices included with the alert symbols.

"**Warning**" refers to personal safety. They alert you to potential danger or harm. Failure to follow warning notices could result in personal injury or death.

"**Caution**" directs attention to general precautions, which if not followed, could result in personal injury and/or equipment damage.

"**Note**" highlights information critical to your understanding or use of these products.

2.3 CONVENTIONS

To assist you in understanding the material in this manual, conventions have been established to enhance reader comprehension. Explanations of these conventions are as follows:

- Safety warnings, cautions, and notes present material that is important to user safety. Be sure to read any safety notices you see as they could prevent equipment damage, personal injury, or even death to you or a co-worker.
- **Bold** text highlights other important information that is critical to system operations.

- CAPITALIZED text stresses attention to the details of the procedure.
- Underlined text emphasizes crucial words in sentences that could be misunderstood if the word is not recognized.

2.3.1 BDS4 vs. BDS4V vs. BDS4A & PSR4/5 vs. PSR4/5A

The BDS4, BDS4V and the BDS4A differ in according to the following:

BDS4	Original Standard Configuration
BDS4V	Industrial Standard Configuration
BDS4A	U.L. 508 Approved Configuration

The BDS4 is the original amplifier developed by Industrial Drives. It was followed by a value analysis version, the BDS4V. The BDS4A was later developed and submitted to UL for approval.

In a similar manner, the PSR4/5 and PSR4/5A follow this scheme:

PSR4/5	Original Standard Configuration
PSR4/5A	UL 508 Approved Configuration

This indicates that the BDS4A and PSR4/5A meet all the safety standards set by the Underwriter Laboratories. Where differences occur between models, special instructions will be indicated in this manual. For the purpose of referencing all amplifiers and power supplies, the nomenclatures BDS4 and PSR4/5 will be used. Check your model number to verify your model.

2.3.2 Model Numbering Scheme

All Industrial Drives components contain a model and serial number printed on a black and gold tag on the front panel. The model number identifies how the equipment is configured. Refer to Appendix C for the model number scheme tables. These tables explain what the model configurations are. You should verify that the model numbers represent the equipment desired for your application. Also verify the compatibility between components of the servo system.

2.3.3 Abbreviations

CCW	Counter Clockwise
CW	Clockwise
DIFF CMD	Differential Command
D/L	Direction Limit
GC	Goldline Cable
GCS	Goldline Cable Set
LED	Light Emitting Diode
NEC	National Electrical Code
P/N	Part Number
R/D	Resolver-to-Digital
Regen	Regeneration
TL	Test Limits
UL	Underwriters Laboratories

2.4 UNPACKING AND INSPECTION



CAUTION

Electronic components in this amplifier are static sensitive. Use proper procedures when handling component boards.

Upon receipt of the equipment, closely inspect components to ensure that no damage has occurred in shipment. If damage is detected, notify the carrier immediately.

Carefully remove packing material and remove the equipment from the shipping container. Do not dispose of shipping materials until the packing list has been checked. Parts that are contained within the shipment, but not physically attached to the equipment, should be verified against the packing list. If any parts are missing, notify Industrial Drives at once.

2.5 INSTALLATION REQUIREMENTS

Proper installation and field wiring are of prime importance when considering the application of servo amplifiers. Many problems may be avoided if installation of the equipment is done properly. Users should familiarize themselves with and follow installation and wiring instruction in addition to all applicable codes, laws and standards. Pay special attention to the following topics when installing Industrial Drives' equipment.

2.5.1 Environmental Considerations

The environment that this equipment is placed in can have dramatic effects on its operation. Industrial Drives recommends that the BDS4 and PSR4/5 be operated and stored under the following conditions:

- Operating Temperature: 0° C to 45° C
- Storage Temperature: -20° C to 70° C
- Humidity: 10% to 90% (Non Condensing)

2.5.2 Enclosures

It is suggested that the BDS4 and PSR4/5 be mounted in a cabinet or other suitable enclosure to protect them from physical and environmental damage. Refer to Appendix D for complete system dimensions.



Allow sufficient clearance for the large "regenerative" heat producing resistor(s) mounted at the upper edge of the PSR4/5 unit and the externally mounted regen (shunt regulator) power resistor(s).

2.6 ASSEMBLY

The BDS4 and PSR4/5 are both constructed prior to shipping from the factory. The only assembly required is the mounting of the devices.

2.6.1 Mounting

Refer to the drawing of your model system in Appendix F for outline and dimensions. Be sure to look at the proper drawing for mounting measurements.

The PSR4/5 and BDS4 modules should be mounted in the vertical position. To minimize cross talk and enhance air flow, maintain a minimum of 20 millimeters (0.75 in.) on either side of each unit and at least 40 millimeters (1.5 in.) of unobstructed space above and below the units.

Depending on the continuous current ratings of the BDS4 and PSR4/5 modules, a total of six (6) amplifiers may be mounted with a single power supply. However, the maximum number of BDS4 amplifiers mounted on either side of the PSR4/5 power supply module must not exceed four (4).

Mounting combinations for the PSR4/5 and BDS4 modules are as follows:

- PSR4/5-X12; a maximum of four (4) BDS4 amplifiers sequentially or "split mounted" (amplifiers are mounted on both sides of the PSR4/5) at either side of the PSR4/5 in descending order of continuous current ratings.
- PSR4/5-X20; a maximum of four (4) BDS4 amplifiers sequentially or "split mounted" at either side of the PSR4/5 in descending order of continuous current ratings.
- PSR4/5-X50; a maximum of six (6) BDS4 amplifiers ("split mounted" only) to either side, not to exceed four (4) amplifiers on a side, mounted in descending order of continuous current ratings.
- PSR4/5-X75; a maximum of six (6) BDS4 amplifiers ("split mounted" only) to either side, not to exceed four (4) amplifiers on a side, mounted in descending order of continuous current ratings.



Refer to The drawing of your model system in Appendix F for the Mounting Hole Pattern information.



Allow sufficient clearance for the large "regenerative" heat producing resistor(s). The internal resistors are mounted at the upper edge of the PSR4/5 unit. The externally mounted regen (shunt regulator) power resistor(s) are mounted above the PRS4/5A unit.

2.6.2 Mounting the External Regeneration Resistor(s)



WARNING

External regenerative resistors are a shock hazard!

Mount these resistors properly! Enclose these resistors to protect personnel and equipment!



CAUTION

External regeneration resistors can become extremely hot!

Allow safe clearance around the resistor(s) enclosures. Proper ventilation must be provided.

Some models of PSR4/5 use an externally mounted regen (shunt regulator) resistor. The resistor kit includes mounting hardware and, depending on the model, a thermal overload relay to be wired in with the resistors. A suitable enclosed location outside the equipment cabinet needs to be set aside for mounting these components while observing the heat and shock requirements of these resistors.

2.7 ELECTRICAL CONNECTIONS



WARNING

Dangerous voltages, currents, temperatures, and energy levels exist in this product and in the associated servo motor(s). Extreme caution should be exercised in the application of this equipment. Only qualified individuals should attempt to install, set-up, and operate this equipment. Ensure that the motor, drive, and the end-user assembly are properly grounded per NEC requirements.

To facilitate wiring, the BDS4 amplifiers must be mounted next to the PSR4/5 power supply module in descending order according to their continuous current ratings. Refer to Section 2.6.



NOTE

In order to adhere to suitable engineering practice, the AC control voltage (115 VAC for the logic bus) must be applied first to activate the control and fault logic circuits prior to applying the main AC voltage.

Follow these precautions:

1. Observe all notes on the wiring diagram.
2. All motor stator leads, signal input leads, resolver leads, encoder leads, and tachometer leads must be shielded.
3. Twist all AC leads to minimize electromagnetic emissions (noise).
4. Avoid running signal leads (must be shielded) in close proximity to power leads, motor stator leads, or other sources of electromagnetic noise.
5. Minimize lead lengths as much as possible.
6. Connect the BDS4 system according to the System Wiring Diagram; pay close attention to the grounding scheme.
7. Provide adequate stress relief for cables.



NOTE

The notes on BDS4 Wiring Diagram (A-93231) give specific wiring details.

Thermal overload protection for the motor is not provided within the PSR4/5 or the BDS4 and must be provided externally. Refer to the National Electrical Code for proper sizing of overload protection.

With the exception of the hook-up of the motor, the main input voltage, and the main Bus+ and Bus- DC voltage, all interface wiring between the BDS4,

Table 2.1. Torque Values

CONNECTING POINTS	BDS4-3-20 AMP UNITS	BDS4-30-55 AMP UNITS	PSR4/5-12-20 AMP UNITS	PSR4/5-50-75 AMP UNITS
AC Input Screws	12 in. lb.	20 in. lb.	12 in. lb.	20 in. lb.
DC Bus Screws	12 in. lb.	20 in. lb.	12 in. lb.	20 in. lb.
Motor Connecting Screws	12 in. lb.	20 in. lb.		
External Regen Screws			12 in. lb.	20 in. lb.
Ground Screws	12 in. lb.	20 in. lb.	12 in. lb.	20 in. lb.

PSR4/5, and other equipment is accomplished by connectors supplied with the BDS4 and PSR4/5 units.

The input/output connections are grouped by connector or terminal block. They are input/output, motor, resolver, AC main power and control voltages, main DC bus, and unregulated DC voltages.

To connect the power bus of the PSR4/5 to the BDS4 amplifiers the following is suggested:

- For PSR4/5-X12 modules, use 600 VAC insulated 14 AWG or larger wire.
- For PSR4/5-X20 modules, use 600 VAC insulated 10 AWG wire.
- For PSR4/5-50 and PSR4/5-75 modules, use 600 VAC insulated 8 AWG or larger wire.

Captive screws are used in the power terminals of the PSR4/5-X12 module, PSR4/5-X20 module, and the 3 amp thru the 20 amp BDS4 amplifiers. Do not attempt to remove these screws to use ring terminals. Use locking spring terminals similar to Hollingsworth #XSS20945S or #SS20947SF for 16 and 14 AWG wire and #XSS20836 or #SS20832F for 12 and 10 AWG wire.

2.7.1 Recommended Torque for Electrical Connections

Table 2.1 displays the recommended torque values for terminal block and grounding connecting points. All torques are measured with the wire or terminal lug underneath the screw head.

2.7.2 Grounding Scheme

To prevent shock hazard to personnel and to ensure proper operation of the servo system, the BDS4, PSR4/5, and the servo motor must be grounded according to NEC specifications. Each BDS4 and PSR4/5 have at least two grounding screws on the front of the chassis.



NOTE

Provisions of the National Electrical Code with respect to grounding should be followed. These precautions generally deal with the ground loop currents arising from multiple ground paths. Only one ground path should be used.

One of the screws on the chassis of the PSR4/5 should go to earth or machine ground. The other should be connected to the adjacent BDS4 ground screw along with the ground wire from the motor. The free ground screw on the BDS4 chassis should then be connected to the next BDS4, etc.

For grounding to machine or earth ground, a screw lug should be attached to the ground screw or stud on the PSR4/5 or BDS4. A torque of 12 in.lb. for ground screws and 20 in.lb. for ground studs is recommended. Also refer to the National Electrical Code (NEC) or UL standard 486B for recommended torque's.

2.7.3 Connecting the AC Input Voltages

The Main AC Input Voltage, either single- or three-phase, should be connected at L_a , L_b , and L_c on the power terminal block located on the front of the PSR4/5 unit. The PSR4/5 is not line-phase sensitive. When using the 12 or 20 amp PSR4/5 with single-phase main power, the input lines may be connected to any two (2) terminals L_a , L_b , or L_c .

The Control AC input voltage should be wired to Connector C1 - Pins 2 and 3 on the PSR4/5 and from Connector C1 - Pins 5 and 6 of the PSR4/5 to Connector C4 - Pins 1 and 2 (fan units only) on the BDS4.



NOTE

Connector C4 is present only on BDS4 Amplifiers that have continuous ratings of 20 amps and above.

2.7.4 Connecting the PSR4/5 Fault Output Contact (Connector C1)

Pins 1,4 Fault Contact

The Fault Output Contact closes when power is applied to the PSR4/5. This contact opens on a fault condition within the PSR4/5 only.

The pinouts for C1 are listed in Figure 2.2. Refer to Note 2 of the BDS4 Wiring Diagram (A-93231) for further information concerning the PSR4/5 Fault Output Contact.

2.7.5 Connecting the Unregulated DC Voltage to the BDS4 (Connector C3)

The wiring between the BDS4 Connector C3 and the PSR4/5 Connector C2 (unregulated voltage) is in Table 2.2 and the pinouts are in Figure 2.3.

2.7.6 Connecting the Main DC Bus Voltage

Refer to notes 4 and 6 on BDS4 Wiring Diagram A-93231 for details concerning the hook-up of the Bus + and Bus - circuits between the PSR4/5 and the BDS4 amplifiers.



WARNING

Failure to observe correct polarity will result in damage to the PSR4/5 and BDS4.

2.7.7 Connecting the External Regeneration Resistor(s)

If an external regeneration resistor is specified, connecting points are provided on the PSR4/5 Power Supply Unit (refer to Notes 3 and 10 on BDS4 Wiring Diagram A-93231).

Table 2.2. BDS4 Unregulated DC Voltages (C3)

VOLTAGE	CURRENT	BDS4 CONNECTOR C3 PINS	PSR4/5 CONNECTOR C2 PINS
+18 V Nominal (+17 V to +26.5 V)	NO LOAD	1, 5	1, 5
-18 V Nominal (-17 V to -26.5 V)	NO LOAD	2, 6	2, 6
COMMON	---	3, 7	3, 7
10 V Nominal (+9 V to +14 V)	NO LOAD	4, 8	4, 8
+ 14.5 V MIN.	1 AMP ON PSR4/5 12 OR 20 AMP UNITS 2 AMP ON PSR4/5 50 OR 75 AMP UNITS	1, 5	1, 5
- 14.5 V MIN.	1 AMP ON PSR4/5 12 OR 20 AMP UNITS 2 AMP ON PSR4/5 50 OR 75 AMP UNITS	2, 6	2, 6
COMMON	---	3, 7	3, 7
+ 6.5 V MIN.	2 AMP ON PSR4/5 12 OR 20 AMP UNITS 4 AMP ON PSR4/5 50 OR 75 AMP UNITS	4, 8	4, 8

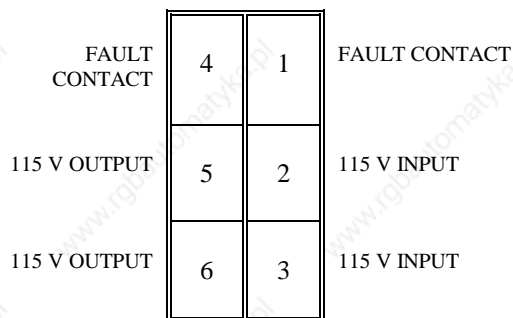

Figure 2.2. PSR4/5 (C1)

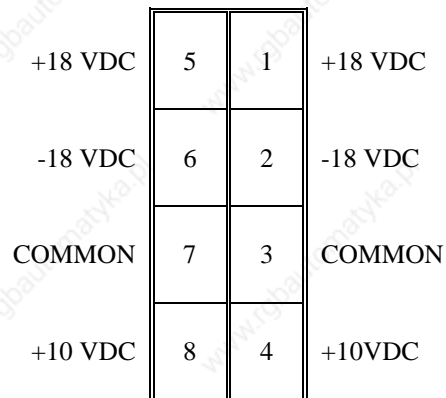

Figure 2.3. BDS4 (C3) & PSR4/5 (C2) (Nominal, No Load Voltages)

DIFF HI	11	1	DIFF LO
AUX IN	12	2	ENABLE
I LIMIT	13	3	RESET
TORQUE HOLD	14	4	DIFF SHIELD
COMMON	15	5	SHIELD
COMMON	16	6	SHIELD
COMMON	17	7	OUTPUT FAULT
I MONITOR	18	8	FOLD BACK
SPEED MONITOR	19	9	OVERTEMP
DRIVE-UP	20	10	DRIVE-UP

Figure 2.4. BDS4 Connector (C1)

2.7.8 Connecting the BDS4 Input/Output (Connector C1)

The following descriptions tell the user which inputs and modes of operation are available, enable the user to identify the appropriate connecting points on Connector C1, and help the user decide which inputs and modes of operation to use. The pinouts are listed in Figure 2.4.

Pins 15,16,17 Common

These pins provide commons (returns) between external equipment (numerical controls, etc.) and the BDS4.

Pins 4,5,6 Shield

These pins provide termination points for cable shields. To insure there are no ground loops in the shield common, connect only one end, butt and insulate the other end.

Pin 11 DIFF CMD HI

Pin 1 DIFF CMD LO

Differential velocity or current command input ± 10 V full scale, 20 K Ohm input impedance. Should be shielded.

Pin 2 Enable

Allows the BDS4 to be enabled or disabled without removing the main power. When a circuit is closed between Pin 2 and common, the BDS4 will be put into the Drive-Up mode. Opening the circuit puts the BDS4 into the Inhibit mode [internal 20 K Ohm pull-up resistor to +12 VDC] (Green LED indicated).

Pin 3 Reset

Allows any latched fault circuit except OVERVOLTS or OVERCURRENT faults to be reset by toggling Pin 3 to common. It has a 20 K Ohm pull-up resistor to +12 VDC.

Pin 7 Output Fault

Open collector signal (logic low) to indicate that either an overcurrent or overvoltage fault has occurred in the Power Stage of the amplifier. 25 ma sink capabilities, 30 VDC Max (red LED indicated).

Pin 8 Foldback

Open collector signal (logic low) to indicate that the amplifier has started to reduce peak current due to excessive loading, 25 ma sink capabilities, 30 VDC max (red LED indicated).

Pin 9 Overtemp

This output will transition low to indicate the BDS4 amplifier is being subjected to an excessive temperature condition. Open collector, logic low, 25 ma sink capability, 30 VDC max (red LED indicated).

Pins 10,20 Drive-Up

The Drive-Up contact closure (internally) indicates to the outside world that the BDS4 amplifier is in the Drive-Up mode; or when the contact is open, it indicates the Inhibit mode. The contact is rated at 115 VAC at 2 amps (green LED indicates Drive Ready).

The Drive-Up relay acts in conjunction with the Enable circuit in one of two possible modes of operation as determined by optional jumper J21. To determine which mode of operation is being utilized, refer to J21 on the TEST LIMITS SHEET.

1. Drive-Up Mode

J21 is not installed on the BDS4-COMP Board.

Apply power.

When the Enable input circuit is activated (pulled low), the internal Drive-Up contact will close and the green Drive Ready LED will become illuminated. However, when the Enable input circuit is not activated, or a fault occurs, the internal Drive-Up contact will be open and the green Drive Ready LED will be off indicating that the BDS4 is in the Inhibit Mode.

If a fault occurs within the BDS4, the Drive Ready LED will turn off and the Drive-Up contact will open and remain open regardless of the state of the Enable input circuit.

2. O.K. to Enable/Drive-Up Mode

JR21 is installed on the BDS4-COMP Board (Standard).

Apply power.

When there are no faults present, the internal Drive-Up contact will be closed and the green Drive Ready LED will be illuminated indicating that the BDS4 is OK-TO-ENABLE. However if there is a fault present, the Drive-Up contact will be open and the Drive Ready LED off indicating that the BDS4 is in a fault mode. In this case, activating the Enable input circuit will not enable the BDS4.

Pin 12 Aux IN

This is an additional single ended input to the velocity loop. This input may be used in adaptive

mode applications or used as the tach input for integrally motor-mounted tachometer generators.

Pin 13 I Limit

The Current Limit input allows access to the Current Limit circuitry providing a means by which inputs may be applied for adaptive control applications.

This single ended input may also be used to adjust the peak current limit of the amplifier from 7.5% to 100% of its rating. A positive voltage from 0 VDC to 7.5 VDC corresponds to 7.5% to 100% respectively. Also, a resistor to common may be used to program the current limit with 75% of I peak = 8.6 K Ohm, 50% of I peak = 3.3 K Ohm. The Current Limit Adjustment Pot may also be used to adjust the peak torque of the motor to the desired level.

Pin 14 Torque Hold

The BDS4 may be converted from a constant velocity amplifier to a constant torque amplifier (at stall only) by closing a circuit between Pin 14 and common (via internal 20 K Ohm pull-up resistor). The velocity loop operational amplifier is maintained at unity gain while in this mode of operation.

Pin 18 I Monitor

There is a direct relationship between the signal appearing at this output and actual motor current. A DC voltmeter placed between Pin 18 and common, calibrated in either current or torque, can be used to estimate the constant load levels placed on the motor. The current scale factor at Pin 18 is $8V = \text{Peak RMS current rating of the BDS4 (3 K Ohm output impedance)}$. This output is for reference only. Its accuracy decreases as current decreases: +/- 4% at peak current, +/-9% at continuous current, +/- 12% at 1/2 continuous current.

Pin 19 Speed Monitor

There is a direct relationship between the signal appearing at this output and actual motor speed. A DC voltmeter (or other instrument) placed between Pin 19 and common, calibrated in RPM, can serve as a means by which speeds may be monitored. Refer to the TL Sheet for the scale factor in volts/RPM (8 volts = maximum speed) as listed on the TL Sheet for the particular motor/amplifier combination (3K Ohm output impedance).

2.7.9 Connecting the Motor



B SERIES MOTORS have a thermostat switch wired to the resolver connector at the motor.

BR SERIES MOTORS have a thermostat switch wired to the stator connector at the motor.



The motor thermostat switch is an automatic resetting device and should be connected directly into a latched (locked out) power down type circuit.



Incorrect motor resolver phasing can cause erratic operation, runaway, or damage to the system.

Terminate Pins A, B, C, D, E, and F of the resolver connector at Connector C2 on the BDS4 as shown by Figures 2.5 and 2.6. Also see the BDS4 Wiring Diagram (A-93231) and the appropriate motor HD (hook-up) drawing or Motor Connection Diagram (A-63542). Use cables with three (3) independently

SIN HI	7	1	SIN LO
SIN SHIELD	8	2	COS SHIELD
COD HI	9	3	COS LO
REF LO	10	4	REF HI
SPARE SHIELD	11	5	REF SHIELD
N/C	12	6	N/C

Figure 2.5. BDS4 (C2)

shielded pairs for the resolver.

The leads of the three-phase synchronous motor are brought out to Pins A, B, and C of the motor connector. Pin D is ground for the motor. Refer to Figure 2.7 for pin connections.

Terminate Pins A, B, and C of the motor connector to Ma, Mb, and Mc, respectively, on the power terminal block located on the front of the BDS4 amplifier. Terminate Pin D at the BDS4 chassis ground screw. Refer to Wiring Diagram (A-93231) and the appropriate motor HD (hook-up) drawing.

The optional integrally-mounted tachometer is brought out to Pins R and S on the resolver connector for both the B and BR series motors. Pin R (Tach Hi) should be terminated at Connector C1 - Pin 12 (Aux In) of the BDS4. Pin S (Tach Lo) should be terminated at Connector C1 - Pin 15 (common) of the BDS4. The tachometer is an option and is not installed on most motors.

2.8 INSTALLATION CHECKLIST

Refer to BDS4 Wiring Diagram (A-93231).

Before applying power to the PSR4/5 and BDS4, check the following items to ensure proper operation:



To prevent damage to the equipment, the motor and resolver, the AC line voltage, and the DC bus voltages must be connected as indicated by BDS4 Wiring Diagram (A-93231).

2.8.1 Checking the Motor and Resolver Wiring

Disconnect both the motor stator and resolver connectors from the motor. Using an ohmmeter, check the continuity of each motor stator lead between the motor stator connector pin and the BDS4. Using an ohmmeter, check the continuity of each motor resolver lead between the motor resolver connector pin and the BDS4. The motor stator and resolver leads should be connected according to BDS4 Wiring Diagram (A-93231). There are no other options for connecting the motor stator and resolver leads.

2.8.2 Checking the AC Line Voltages

Open the circuit breaker or remove the fuses in the Main AC lines that are connected to the PSR4/5 at L_a, L_b, and L_c. Remove Connector C1 from the PSR4/5, and remove (if present) Connector C4 from the BDS4.

Apply only the AC main power. Use an AC voltmeter to check and record the 1- or 3-phase line-to-line voltage at the circuit breaker or fuse holders. Remove power. Note the model number of the PSR4/5 and refer to Appendix B to confirm the correct Main AC voltage level.

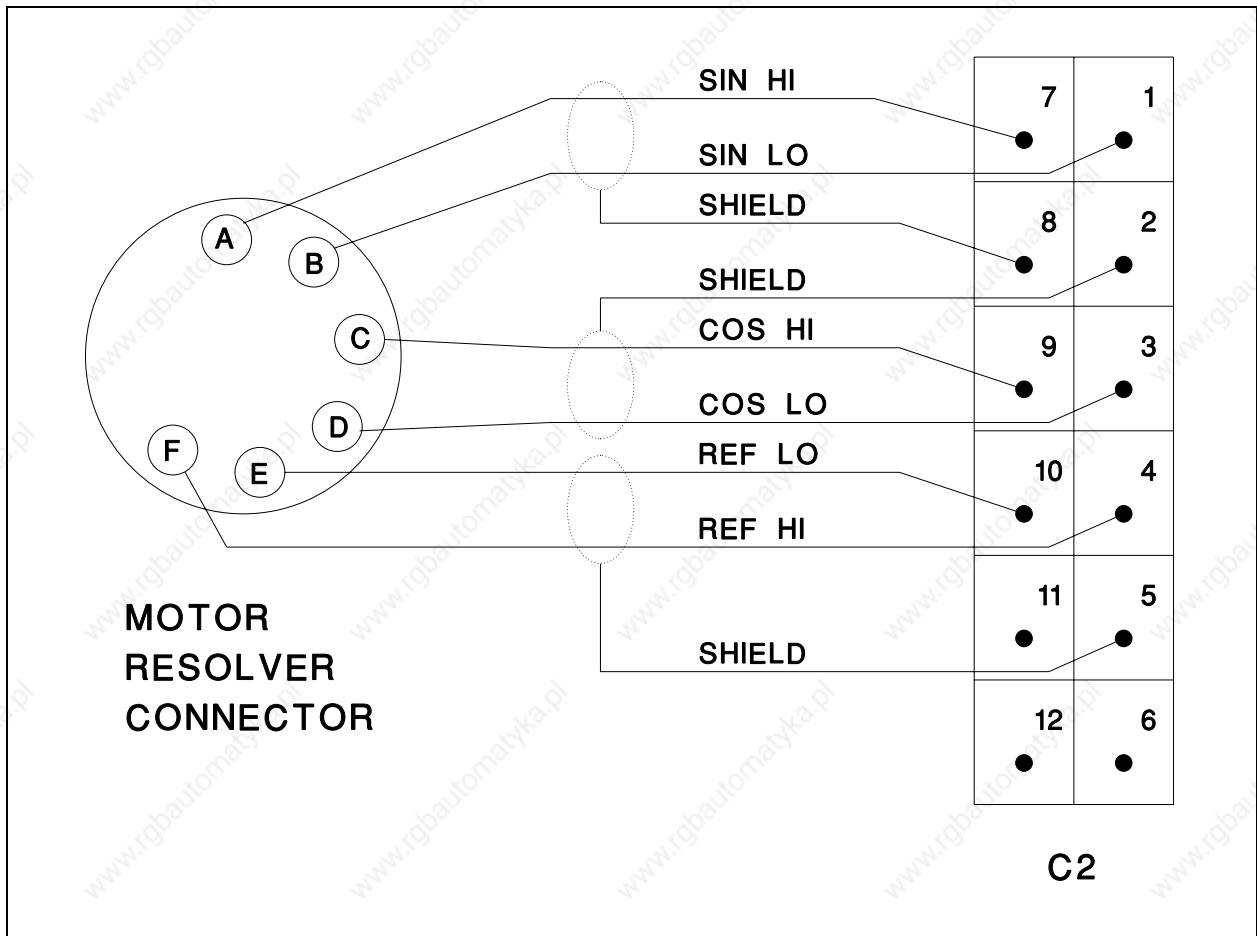

Figure 2.6. Motor Resolver Connections

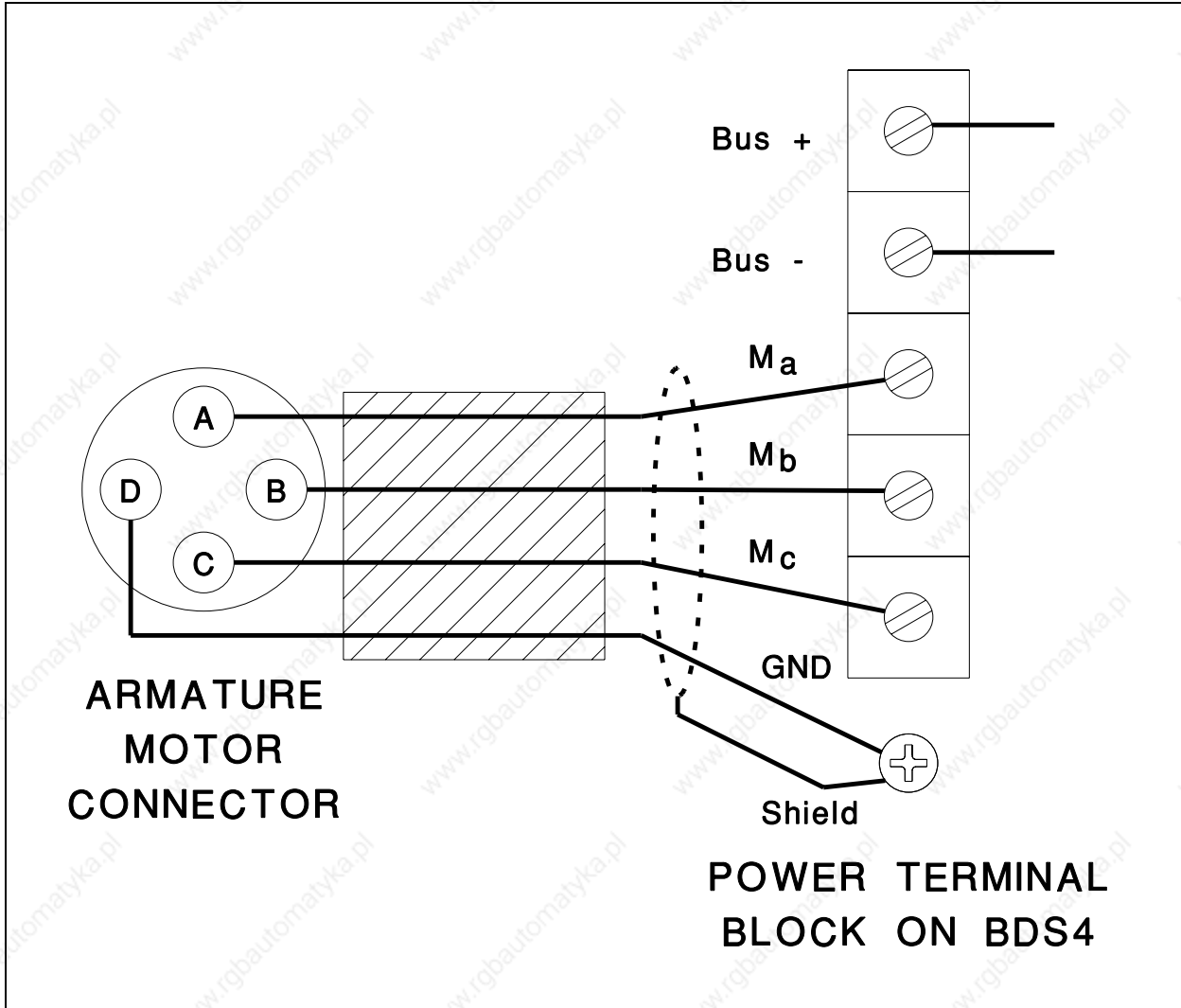

Figure 2.7. Armature Motor Connections

Apply only the AC control power. Use an AC voltmeter to check and record the single-phase voltage at Connector C1 of the PSR4/5. Remove power. Note the model number of the PSR4/5 and refer to Appendix B to confirm correct Control AC voltage level.

If the voltage levels are within the specifications listed in Appendix B, proceed with the Check-Out procedure.

Close the circuit breaker or re-install the fuses for the Main AC input power. Re-install Connectors C1 and C4 (if present).

2.8.3 Checking the DC Bus Voltages



WARNING

Allow sufficient time (after removing power from the system) for the voltage to bleed down before connecting or disconnecting wires at the bus.

Remove power.

Remove the Bus+ and Bus- leads from the PSR4/5 power terminal block. Remove mating Connector C2 from the PSR4/5.

Apply power.

Check and record the Main DC Bus Voltage output at (+) with respect to (-) on the PSR4/5 terminal block according to Section 2.1. Check and record the unregulated DC voltage levels at Connector C3 of the PSR4/5. They should be ± 17 to 26.5 and + 9 to 14.5 VDC per Section 2.7.5.

Remove power.

Note the model number of the PSR4/5 and refer to Section 2.1 to confirm DC voltage levels.

If the voltage levels are within the specifications listed in Appendix D, proceed.

WAIT FOR THE BUS TO BLEED DOWN and reconnect the B(+) and B(-) leads to the power terminal block of the PSR4/5. Be careful to reconnect the leads with the proper polarity. Re-install Connector C2 on the PSR4/5.



Failure to observe correct polarity will result in damage to the PSR4/5 and BDS4.

CHAPTER 3

OPERATION

3.1 INTRODUCTION

The information in this chapter will enable you to become familiar with system components and their dependence upon one another. Also, it will help you ensure each component is configured and functions properly. At this point, all safety stops and other precautions should be in place and working properly. Be prepared to stop the machine if necessary.

3.2 INITIAL START-UP

You should now be ready to supply power to test the servo systems functions and features. Work with only one axis section at a time. Confirm all other BDS4 amplifiers are inhibited, meaning the enable circuits are open (high).



Incorrect servo-to-position loop phasing can cause excursion oscillations, or runaways.

Appropriate precautions should be taken to stop the machine if necessary. Limit switches and safety devices should be in place.



CAUTION

Unloaded motors, compensated for a large inertia mismatch, may become unstable when the system is activated. Refer to the test limits (TL) sheet for stable load inertia range. If the system becomes unstable, remove the power immediately.

3.3 SEQUENCE OF OPERATIONS

This section contains a basic start-up sequence that should be followed the first time the servo system is initialized. **READ THIS ENTIRE SECTION BEFORE PERFORMING ANY OF THESE PROCEDURES.** When you apply power to the system, pay special attention to the LEDs on the BDS4 front panel. The CONTROL VOLTS and DRIVE READY (green) LEDs should be illuminated. This indicates that the system is functioning properly. Should a FAULT (red) LED remain on for more than a instant, immediately disconnect power and consult Chapter 5 - Troubleshooting.

1. Apply power. Enable only one BDS4. Observe the action of the machine. If the direction of the motor shaft rotation is reversed

(motor shaft turns in the wrong direction),
remove power.

- Reverse the input to the BDS4 at DIFF CMD HI and DIFF CMD LO at Connector C1, Pins 1 and 11. **DO NOT ATTEMPT TO REVERSE DIRECTION OF ROTATION BY INTERCHANGING MOTOR LEADS AND/OR RESOLVER LEADS.**

If the servo system performed properly, then read Chapter 4 - Maintenance for adjustments and other information that may be helpful in adapting your system to your own applications.



NOTE

If the motor is commanded to move and does not respond, turn the command scale adjustment several turns CW.

CHAPTER 4

MAINTENANCE

4.1 INTRODUCTION

The information in this chapter will enable you to maintain the systems components ensuring smooth, efficient operation of the motor. Adjustments to the system are broken in three (3) categories: Set-Up, Response and Application Dependent, and Design Tolerance. These adjustments allow the user to tailor the BDS4 to their specific applications.

4.2 PREVENTATIVE MAINTENANCE



Preventative maintenance to this equipment must be performed by qualified personnel familiar with the construction, operation, and hazards involved with the application.



Electronic components in this amplifier are static sensitive. Use proper procedures when handling component boards.

Preventative maintenance should be performed with the BDS4 system out of operation and disconnected from all sources of power.

4.2.1 Transient Voltages



All transient-producing devices must be properly suppressed.

Solid state controls of the BDS4 may be affected by transient voltages. These voltages are in excess of the specified voltage for any given circuit. When these peak voltages occur, even for less than a second, permanent damage to the BDS4 can occur.

In order to help avoid transient voltages that may interfere with electronic circuit functions within the PSR4/5 and BDS4, all switched inductive devices or their wiring (solenoids, relay coils, starter coils, etc.) must be suppressed. A 220 ohm, 1/2 watt resistor in series with a 0.5 micro farad, 600 volt capacitor or equivalent is suggested.

4.2.2 Surge Current

Excessive current greater than that of the specified limits of the PSR4/5 and BDS4 can cause permanent damage to the system. Current limiting means are recommended to protect from these currents.

**CAUTION**

If the short circuit inrush current generated by the power source is in excess of 5000 amps RMS symmetrical current, an isolation transformer or line inductor must be utilized in the incoming power circuit. Failure to observe this precaution could result in damage to, or destruction of the PSR4/5 and BDS4.

Input transformers step up or step down input voltage and can be either autotransformers or isolation transformers. Isolation transformers help eliminate the following:

- Damaging AC line voltage transients reaching the PSR4/5 and BDS4.
- Damaging currents which may develop if a point inside the PSR4/5 or BDS4 becomes grounded.

4.2.3 Electrical Noise

The low levels of energy in the BDS4 control circuits may cause them to be vulnerable to electrical noise. Sources of electrical noise are those pieces of equipment that have large, fast changing voltages and currents when they switch on and off. These devices have the capability of inducing critical current and voltage transients on their respective power lines. These transients must be accommodated for with noise immunity provisions.

Electrical noise is prevented with the same methods as Surge Current and Transient Voltages. However, there are other methods of preventing electrical noise. Such as:

- Maintain physical separation between electrical noise sources and the BDS4 amplifier.
- Maintain physical separation between electrical noise sources and the BDS4 control wiring. This can be accomplished by using separate conduits or wiring trays for control wiring and power wiring.

- Use twisted-pair wiring for control circuits of the BDS4.
- Follow good grounding practices when wiring the PSR4/5 and BDS4. Be careful not to create a grounding loop with multiple ground paths. Follow the NEC's provisions on grounding.

4.2.4 Radio Frequency Energy

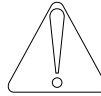
**NOTE**

This equipment generates radio frequency energy.

This equipment uses, and can radiate radio frequency energy and must be installed and used in accordance with this installation and service manual in order to prevent possible interference with radio communications or other electronic equipment.

4.3 PERIODIC MAINTENANCE

Periodic maintenance must be performed by qualified personnel familiar with the construction, operation, and hazards involved with the BDS4 and its application. Power should be disconnected during all maintenance procedures.

4.3.1 Ventilation

The PSR4/5 and BDS4 should be mounted vertically to allow maximum ventilation of the components. This configuration allows the heat generated by the components to vent through the top and draft in cooler air through the bottom. The top and bottom of the components are vented to allow this drafting to occur. These ventilation passages should be kept open. If the PSR4/5 requires auxiliary cooling with fans, inspect the fans on a regular basis.

4.3.2 Grounding Integrity

The method employed for grounding or insulating the equipment from ground should be checked to assure its integrity on a regular basis. This check should be performed with the power off and the testing equipment grounded.

4.4 ADJUSTMENTS



NOTE

Adjust pots with proper adjustment tool.

DO NOT FORCE.

The adjustments are classified into three categories:

1. Set-Up Adjustments - Adjustments that are necessary at installation (accessible at the front of the BDS4).

Motor System Resolver Phasing and Alignment - Should be checked the first time (if I.D. cables are not used).

Balance Adjustment.

Command Scale Adjustment.

2. Response and Application Dependent Adjustments - These adjustments add versatility to the BDS4 and allow it to be "tailored" to specific applications (accessible at the front of the BDS4).

Stability Adjustment.

Current Limit Adjustment.

3. Design Tolerance Adjustments - Factory set and sealed adjustments should never require customer adjustment (internal adjustments).

Current Sensor Offset Adjustments - Pots AZ and CZ.

Resolver Excitation Adjustment - Pot OSCG.

FACTORY ONLY ADJUSTMENTS - Pots R/DTR, R/DG, and R/DZ.

4.4.1 Set-Up Adjustments

At equipment start-up, make these adjustments.

4.4.1.1 Balance Adjustment (Within Position Loop)

If a monitor or readout displays Following Error, adjust Balance Pot for zero Following Error at zero speed.

Optional: Monitor DIFF CMD HI with respect to DIFF CMD LO with a DC voltmeter. Command zero speed from the Numerical Controller. Adjust Balance Pot for zero volts on the meter.

4.4.1.2 Balance Adjustment (Automatic or Manually Operated Machines)

Monitor DIFF CMD HI with respect to DIFF CMD LO with a DC voltmeter. With the input signal at zero volts or with the input shorted to common, adjust Balance Pot for zero speed.

4.4.1.3 Command Scale Adjustment (Within Position Loop)

If the following error is displayed by monitor or readout, command a slow feed rate and adjust Command Scale Pot for the proper amount of Following Error at that speed.

4.4.1.4 Command Scale Adjustment (Automatic or Manually Operated Machines)

Turn the Command Scale Pot fully CCW. Apply an input signal level which equals maximum desired motor speed in RPM. Adjust Command Scale Pot CW for maximum desired motor speed. **DO NOT EXCEED THE MAXIMUM MOTOR SPEED THAT IS LISTED ON THE TL SHEET FOR THE SYSTEM.**

Refer to the Test Limits Sheet (TL) to identify the maximum scaling of input signal. Maximum ± 10 volts is standard.

4.4.2 Response and Application Dependent Adjustments

These adjustments allow versatility in altering the dynamic response of the BDS4 system as needed.

When altering the response of the system, it may be necessary to adjust both the STABILITY and the CURRENT LIMIT adjustments.

4.4.2.1 Stability Adjustment

In many cases, the Stability Pot will not need to be adjusted and may be left in its fully CCW position.

However, this pot can be used to improve the dynamic response of the servo loop, by adjusting the Dynamic (AC) Gain. To adjust the AC Gain to the proper point, use an oscilloscope to monitor the internal tach signal at the SPEED MONITOR test point with respect to A-COM (refer to Figures 1 and 3). Use a second channel of the scope to monitor the current signal at the I MONITOR test point, also with respect to A-COM (refer to Figures 1 and 3). Turn the STABILITY Pot fully CCW. Apply a step input (rapid) command signal. While accelerating and decelerating the motor at approximately 25% of maximum speed, adjust the STABILITY Pot CW and notice the tach and current wave forms at the SPEED MONITOR and I MONITOR test points. Watch for indications of instability (i.e., ringing) in the wave forms while accelerating and decelerating the motor. Turn the STABILITY Pot CCW until the tendency to go unstable disappears.

4.4.2.2 Current Limit Adjustment

The maximum peak current limits are set at the factory and can not be increased above the level listed on the Test Limits sheet (TL). Although the peak current limits cannot be increased above the specified value, they may be decreased.

To reduce the peak current limit level, apply a step input command signal. Use an oscilloscope to monitor the I-MONITOR test point (refer to Figures 1 and 3). Accelerate and decelerate the motor. Adjust the CURRENT LIMIT Pot for desired peak current limit. The current scale factor at the I MONITOR test point is $8V = \text{Peak RMS rating of the BDS4}$ (refer to Section 2.2 for Peak Rating and Section 4.1 for more information on this signal).

4.4.3 Design Tolerance Adjustments (Factory Set and Sealed)

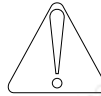

NOTE

These adjustments should not be made in the field. They have been factory set and sealed and should never require adjustment.

The following procedures are to be followed only if the seals are broken.

4.4.3.1 Resolver Excitation Adjustment

Inhibit the BDS4 by opening the Enable input circuit.

Using an oscilloscope, monitor REFERENCE HIGH at TC2-1 (refer to Figure 1 or 3). Adjust Pot OSCG (inside the BDS4) for 12 volts peak-to-peak. This signal should be $7.0 \text{ kHz} \pm 500 \text{ HZ}$.

4.4.3.2 Current Sensor Offset Adjustments

Using a digital DC voltmeter, monitor TC4-1. Adjust Pot AZ (inside the BDS4) for minimum voltage level. Using the digital voltmeter, monitor TC4-3 and adjust Pot CZ (inside the BDS4) for minimum voltage level. Refer to drawing C-84113.

4.4.3.3 Motor System Resolver Alignment

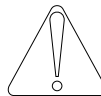

NOTE

This procedure applies only to the system resolver, not the application (position loop) resolver.

The motor system resolver is properly aligned at the factory and should never require realignment. However, this procedure is included here in the event (motor repair, etc.) the resolver should ever need realignment.

In order for the following test to be valid, the motor and resolver phasing must be correct. If there is any doubt as to whether the motor and resolver are wired correctly, refer to Section 4.6 and check the motor and resolver wiring.

The motor system resolver alignment can be confirmed by conducting the following test:

1. Remove power. Disconnect the motor shaft from any mechanical load.
2. Connect a small jumper between TC1-3 and TC1-4 (refer to Figures 1 and 3). While in this mode (resolver zeroing test mode), the FOLDBACK LED will become the resolver alignment indicator.
3. Apply power. **DO NOT ENABLE THE BDS4.** If necessary have a colleague observe the FOLDBACK LED. The FOLDBACK LED will be either off or slowly blinking. Slowly rotate the motor shaft until the FOLDBACK LED blinks at its fastest rate (rotate slowly then pause, giving the circuitry time to react). The closer the resolver is to being correctly aligned, the faster the LED will blink. The LED should be somewhere between one pulse per second and fully illuminated when it blinks at its fastest rate.



Remove hand from motor shaft before enabling. The shaft will jerk into position with some force.

4. Enable the BDS4 by pulling Connector C1-Pin 2 on the BDS4 to common. The internal software of the BDS4 will cause phase M_a to have zero current. The M_b and M_c phases will have equal, but opposite, currents causing the motor shaft to align itself in a neutral position. The FOLDBACK LED should be fully illuminated indicating correct alignment of the resolver. No further attempt at alignment is necessary. Resolver alignment is correct.
5. If, however, the LED does not become fully illuminated as indicated in Step 4 above, proceed with the alignment procedure.

Inhibit the BDS4.

Remove power.

Remove the end plate (cover) from the rear end of the motor. The shaft-mounted frameless resolver will be in sight.

The frameless resolver rotor is slid forward onto the motor shaft and secured by a large lock nut. This part of the resolver should not be disturbed.

6. Loosen, but do not remove, the two servo clamp screws holding the resolver stator secure. **DO NOT MOVE THE POSITION OF THE MOTOR SHAFT.**
7. Apply power. If necessary, repeat Step 3 above. Enable the BDS4. Slowly rotate the resolver stator (outside element) while a colleague watches the FOLDBACK LED on the front of the BDS4 amplifier.

If the LED does not become fully illuminated, turn the resolver stator in the opposite direction. Continue to rotate the resolver stator until the LED becomes fully illuminated. If the correct alignment position is passed, the LED will blink more slowly. When the LED becomes fully illuminated, discontinue turning the resolver stator and tighten the two servo clamp screws.

Inhibit the BDS4.

Remove power.

8. Repeat Steps 3 and 4 above.

9. Inhibit the BDS4.

Remove power.

Remove the jumper from the test points.

Replace the motor end cover.

4.4.3.4 Factory Only Adjustments

Do not adjust Pots R/DTR, R/DG, and Pot R/DZ. These pots are set and sealed at the Factory and cannot be adjusted in the field. If these pot seals are ever broken, return the complete BDS4 amplifier to the Factory for alignment.



WARNING

CHAPTER 5

TROUBLESHOOTING

5.1 INTRODUCTION

The information in this chapter will enable you to isolate and resolve common system hardware problems. The troubleshooting methods in this manual isolate each component from the system until the problem is resolved.

The only user-serviceable items on the PSR4/5 are the output line fuses in the control DC voltage supply and (in the 12 and 20 amp units) the shunt regulator regeneration load resistor fuse.

5.2 FIELD SERVICEABILITY



CAUTION

Dangerous voltages exist in this equipment. Also, motor temperature may exceed 100 °C. Extreme caution should be exercised when troubleshooting this equipment. Only qualified individuals should attempt to install, setup, operate, or troubleshoot this equipment.

The BDS4 and PSR4/5 are designed to promote minimum down time situations. Due to the compact package size and to the fact that there are few user-serviceable components on the modules, it is recommended that they be replaced if they cease to function properly. Return the modules, in their entirety, to Industrial Drives for repair.



CAUTION

To preserve the level of protection for the product as designed, replacement fuses must be the exact same style and ampere rating as those originally installed.

The BDS4 modules may be interchanged, provided the following guidelines are adhered to:

1. The BDS4 modules must be the same rating.
2. The motors being controlled must bear the same model number.
3. In the event the motors have different model numbers, the BDS4-COMP Board must bear the model number of the motor being controlled or the BDS4-COMP Board must be altered, per TL (Test Limits Sheet) to make the BDS4 compatible with the motor.

Before beginning the troubleshooting process, consider the following points:

- I. There are four (4) distinct areas within which a fault may occur:

- A. External Interface (Circuitry external to, but connecting to, the BDS4.)
 - B. BDS4 Amplifier Module
 - C. PSR4/5 Power Supply Module
 - 1. Main DC bus voltage
 - 2. Control DC bus voltages
 - 3. Shunt Regulator Regeneration Circuitry
 - 4. Soft-Start/Dynamic Bus Discharge Circuitry
 - D. Motor
 - 1. Resolver
 - 2. Tachometer (Optional)
- II. There are only two (2) basic fault characteristics to be considered:
- A. The motor exhibits very low torque or is totally inoperative.
 - B. The motor is erratic or exhibits an improper mode of operation.

5.3 SYMPTOMS AND CORRECTIONS

If the motor does not respond or responds in a manner other than with smooth operation, remove power and troubleshoot the system with the following guidelines. Also refer to Table 5.1 for more improper motor operation symptoms.

5.3.1 The Motor Exhibits Very Low Torque or is Totally Inoperative

Prerequisites for motor movement:

1. The BDS4 and PSR4/5 must be wired correctly, per BDS4 Wiring Diagram (A-93231).
2. All power must be present.

3. The BDS4 must be in the Enable mode, as indicated by the green CONTROL VOLTS, ENABLE, and DRIVE READY LED's.
4. A command signal (other than zero volts) must be present at the input of the BDS4.
5. Command Scale Adjustment should not be fully CCW.
6. Fault circuits must not be activated. Fault modes are identified by red LED's located on the front of the BDS4 and PSR4/5 modules.

5.3.2 The Motor is Erratic or Exhibits an Improper Mode of Operation.

Prerequisites for proper motor operation:

1. Proper grounding scheme must be provided. The motor ground wire should be connected as shown by BDS4 Wiring Diagram A-93231.
2. Motor armature leads must not be run in conduit or wire ducts with any signal carrying conductors.
3. The resolver leads, tach leads (when used), and motor armature leads must be wired according to BDS4 Wiring Diagram A-93231.
4. The motor system resolver must be set at its zero point (refer to Section 4.4.3.3).
5. Stability Adjustment should not be fully CW.
6. The motor should be loaded with its specified load inertias — see TL sheet for stable load inertia range. Otherwise, the BDS4 may become unstable.

5.3.3 BDS4-3, 6, 10, 20, 30, 40 and 55 AMP STATUS LED'S

The status of the BDS4 modules is indicated by three (3) Green and six (6) Red LED's. Refer to Figure 5.1 for the LED configuration. The diagnostic information indicated by these LED's is listed as follows:

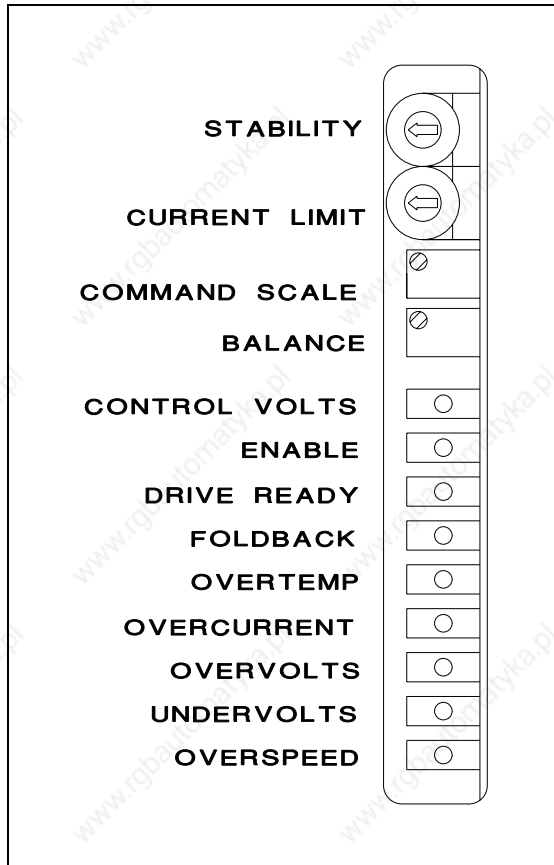

Figure 5.1. BDS4 Status LED's

- Approximately one second after all power is applied, the green CONTROL VOLTS LED on the front of the BDS4 module should become illuminated to indicate that the Control AC line input voltage is applied.
- When the Enable input circuit of the BDS4 is closed, the green ENABLE LED should become illuminated indicating that the BDS4 is now in the enabled mode.
- No fault (red) LED's should be illuminated.
- The green DRIVE READY LED may or may not be illuminated, depending on whether or not jumper J21 is installed on the BDS4-COMP Board.

The red FOLDBACK LED will become illuminated during any situation where the RMS current exceeds the continuous rating of the BDS4 (peak current is allowed for only 2.0 seconds). The LED indicates that the peak current of the BDS4 is automatically being reduced to the RMS continuous rating. Once the current demand is reduced, the FOLDBACK

circuit will reset and the LED will turn off. This LED acts only as an indicator.

If the red OVERTEMP LED becomes illuminated, the BDS4 will become latched in the Inhibit mode indicating an overheated BDS4 heatsink.

When the red OVERCURRENT LED becomes illuminated, it indicates an overcurrent condition usually due to a shorted load (motor), wiring, or BDS4 power stage transistor. The BDS4 will become latched in the Inhibit mode.

If the red OVERVOLTS LED becomes illuminated, the BDS4 will become latched in the Inhibit mode, indicating the presence of excessive main DC bus voltage.

When the red UNDERVOLTS LED becomes illuminated, the BDS4 will be put into the Inhibit mode (but not latched) indicating the main DC Bus is insufficient or absent.

If the red OVERSPEED LED becomes illuminated, the BDS4 will become latched in the Inhibit mode indicating that the motor has obtained an excessive speed, or the resolver cable is miswired or has an intermittent connection.

The Fault Output contact located within the PSR4/5 power supply module will not be affected by any faults occurring within the BDS4.

More diagnostic information about the BDS4 is listed in the Table 5.2.

5.3.4 PSR4/5-12 and 20 Amp Status LED's

The status of the PSR4/5-12 and 20 amp modules is indicated by one (1) Green, one (1) Yellow, and two (2) Red LED's. Refer to Figure 5.2 for the LED configuration. The diagnostic information indicated by these LED's is as follows:

- Approximately 0.25 seconds after the main power is applied, the green DC BUS LED will become illuminated to indicate the presence of voltage on the main DC bus capacitors. Voltage indication may range in magnitude from over 300 VDC, during normal operation with AC line voltage applied, to below 50 VDC

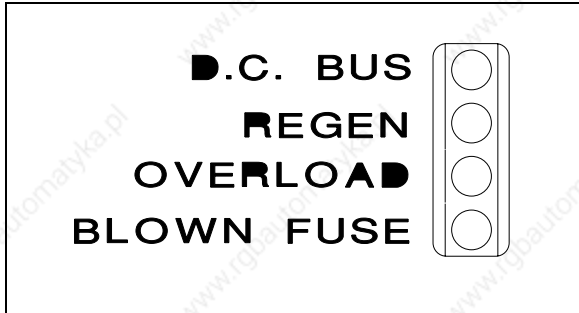

Figure 5.2. PSR4/5 12,20 Status LED's

when the line voltage is removed but the bus capacitors have not completely discharged.

The yellow REGEN LED is for monitoring purposes only. When this LED becomes illuminated, the shunt regulator regeneration circuit is active. No fault is indicated.

The red OVERLOAD LED will become illuminated in the event the shunt regulator regeneration circuit experiences an overload condition. The Fault Output contact will also open.

The red BLOWN REGEN FUSE LED will become illuminated and the Fault Output contact will open in the event the shunt regulator regeneration fuse blows.

Faults occurring within the PSR4/5 will cause its Fault Output contact to open.

More diagnostic information about the PSR4/5 12 and 20 Amp LED's is listed in Table 5.3.

5.3.5 PSR4/5-50 and 75 Amp Status LED's

The status of the PSR4/5-50 and 75 amp models is indicated by one (1) Green, one (1) Yellow, and one (1) Red LED. Refer to Figure 5.3 for the LED configuration. The diagnostic information indicated by these LED's is as follows:

Approximately 0.5 seconds after the main power is applied, the green DC BUS LED will become illuminated to indicate the presence of voltage on the main DC bus capacitors. Voltage indication may range in magnitude from over 300 VDC, during normal operation with AC line voltage applied, to below 50 VDC

when the line voltage is removed but the bus capacitors have not completely discharged.

The yellow REGEN LED is for monitoring purposes only. When this LED becomes illuminated, the shunt regulator regeneration circuit is active. No fault is indicated.

The red FAULT LED, when illuminated, indicates an excessive heatsink temperature within the unit due to an overload condition and may also indicate excessive ambient temperature.

Faults occurring within the PSR4/5 will cause its Fault Output contact to open.

More diagnostic information about the PSR4/5 50 and 75 Amp LED's is listed in Table 5.4.

5.3.6 BDS4 or PSR4/5 Reset Procedures

To reset the OVERVOLTS and OVERCURRENT fault latches within the BDS4 and all fault latches within the PSR4/5 power supply units, remove all AC line input voltage for at least five (5) minutes or until the power stage capacitors are fully discharged. All other fault latches within the BDS4 amplifiers may be reset by toggling the RESET input circuit to common or by removing and reapplying the input voltage as described previously.

The thermal overload relay with the PSR4/5 50 and 75 amp modules External Regen Resistor(s) is normally furnished and set for "HAND" reset operation. In the event of excessive shunt regulator activity, its auxiliary contact will open. (THIS CONTACT MUST BE WIRED INTO THE E-STOP STRING OR AN EQUIVALENT SHUNT DOWN CIRCUIT.) The thermal overload relay may be reset by pushing in the reset rod located in the top of the unit.

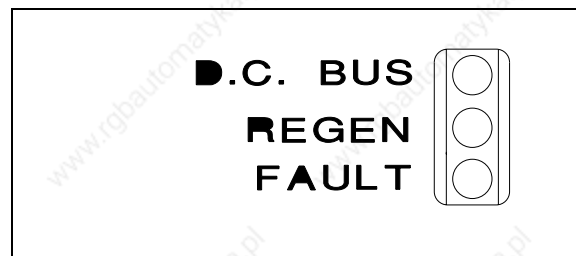

Figure 5.3. PSR4/5 50,75 Status LED's

Table 5.1. Improper Motor Operation Troubleshooting

SYMPTOM	PROBABLE CAUSE
Incorrect Direction of Motor Shaft Rotation	(a) Invert input command signal at Connector C1-1 and 11.
 DO NOT ATTEMPT TO REVERSE DIRECTION OF ROTATION BY INTERCHANGING MOTOR LEADS AND/OR RESOLVER LEADS.	
Motor Drifts Slowly with Zero Input	(a) Adjust balance Pot for zero speed (in position loop for zero Following Error or zero input signal).
Uncontrolled Excessive Speed	(a) Motor and/or resolver leads incorrectly connected.
	(b) BDS4 backwards in position loop (motor shaft turns in wrong direction).
	(c) Incorrect alignment of system resolver (refer to Section 4.4.3.3).
	(d) Defective BDS4-COMP Board.
Motor Erratic	(a) Motor and/or resolver leads incorrectly connected.
	(b) Incorrect alignment of system resolver (refer to Section 4.4.3.3).
	(c) Improper grounding scheme (noise corrupting the input signal, tach signal when used, and/or resolver signals).
System Unstable	(a) Stability Pot improperly adjusted.
	(b) Unloaded motor (load motor with TL specified load inertia).
	(c) Incorrect compensation. Check BDS4-COMP Board against TL Sheet.

Table 5.2. BDS4 Status LED Indicator Troubleshooting

SYMPTOM	PROBABLE CAUSE
1) Control Volts LED (Green) <u>Not</u> Illuminated	(a) Control AC line input voltage out of spec or had a momentary interruption. (b) Unregulated logic bus not applied to BDS4 from PSR4/5 due to defective wiring or being miswired (fuses inside of PSR4/5 may be blown). (c) Defective logic bus supply in BDS4 or PSR4/5 or blown logic bus fuse. (d) Defective BDS4.
2) Enable LED (Green) Not Illuminated	(a) Enable input circuit not pulled low. (b) Defective BDS4.
3) Drive Ready LED (Green) Not Illuminated	(a) BDS4 faulted (see Red LED's). (b) BDS4-COMP Compensation Board not installed or misinstalled. (c) Reset input activated (active low). (d) Defective BDS4.
4) Foldback LED (RED) Illuminated	(a) BDS4 in resolver alignment test mode (refer to Section 4.4.3.3). (b) Excessive RMS current causing BDS4 I ² t protection circuit to activate. Reduce motor duty cycle.
5) Overtemp LED (RED)	(a) Excessive heatsink temperature due to overload or high ambient temperature. (b) Defective BDS4.
6) Overcurrent LED (RED) Illuminated	(a) When this LED becomes illuminated, an overcurrent condition [usually due to a shorted load (motor stator winding), shorted stator wiring, or a shorted BDS4 power stage component] is indicated. If this LED becomes illuminated, remove the power and disconnect the motor. Reapply power. If the BDS4 comes up without this LED becoming illuminated, suspect a faulty motor or motor stator wiring. If the BDS4 comes up with the LED illuminated, suspect a faulty BDS4 power stage.
7) Overvolts LED (RED)	(a) This LED will become illuminated if the Main DC Bus rises above 230 VDC for 115 VAC system, 430 VDC for the 230 VAC system. This can happen due to PSR4/5 fault or inadequately sized shunt regulator regeneration resistor.
8) Undervolts LED (RED)	(a) This LED will become illuminated if the Main DC Bus is insufficient or absent.
9) Overspeed LED (RED)	(a) In the event the motor obtains an excessive speed, the OVERSPEED fault circuit will activate, latch the BDS4 in the inhibit mode, and this LED will become illuminated. (b) Miswired or intermittent resolver cable.

Table 5.3. PSR4/5 12 & 20 Amp Status LED Troubleshooting

SYMPTOM	PROBABLE CAUSE
1) DC BUS LED (Green) <u>Not</u> Illuminated	(a) Main DC Bus insufficient or not present. AC input power not applied; check input line fuses.
2) Regen LED (Yellow) Illuminated or Flashing	(a) Not a fault condition. Indicates regeneration circuit activity.
3) Overload LED (Red) Illuminated	(a) Main DC Bus voltage excessively high due to high Main AC line input voltage.
	(b) Shunt regulator regeneration circuit overload.
	(c) Defective PSR4/5.
4) Blown Regen Fuse LED (Red) Illuminated	(a) Shunt regulator regeneration resistor sized too small.
	(b) Defective PSR4/5.

Table 5.4. PSR4/5 50 & 75 Amp Status LED Troubleshooting

SYMPTOM	PROBABLE CAUSE
1) DC Bus LED (Green) <u>Not</u> Illuminated	(a) Main DC Bus insufficient or not present. AC input power not applied; check input line fuses.
2) Regen LED (Yellow) Illuminated or Flashing	(a) Not a fault condition. Indicates regeneration circuit activity.
3) Fault LED (Red) Illuminated	(a) Excessive heatsink temperature due to overload or high ambient temperature.
	(b) Defective PSR4/5.

**NOTE****Consult Factory if fault occurs during hard deceleration.**

CHAPTER 6

SPARE PARTS

6.1 INTRODUCTION

The information in this chapter will enable you to obtain spare parts for your Industrial Drives equipment. Use these tables to order any parts that have become defective or that are required for specific configurations. Ordering instructions are also provided.

6.2 RECOMMENDED SPARE PARTS

It is recommended by Industrial Drives that you have available for use in your BDS4 and PSR4/5, the parts listed in Tables 6.1 and 6.2. It is also very important to note that there are no user serviceable parts on either component other than those fuses and connector kits listed.

Table 6.1. BDS4 Spare Parts List

DESCRIPTION	PART NUMBER	QUANTITY PER UNIT
Connector Kit	BDS4C-100 (3, 6, and 10 amp models)	1
	BDS4C-101 (20 amp model)	1
	BDS4C-200 (30, 40, and 55 amp models)	1

Table 6.2. PSR4/5 Spare Parts List

DESCRIPTION	PSR4/5 MODEL	PART NO.	QUANTITY PER UNIT
CONNECTOR KIT	ALL 12 AND 20A	PSR4/5C-100	1
CONNECTOR KIT	ALL 50 AND 75A	PSR4/5C-200	1
CONTROL VOLTS FUSES	ALL 12 AND 20A	A-78896-008 (1.5 AMP) FUSE 99, 102	2
		A-78896-012 (4 AMP) FUSE 126	1
CONTROL VOLTS USES	ALL 50 AND 75A	A-78896-012 (4 AMP) FUSE 64,65	2
		A-78896-016 (8 AMP) FUSE 24	1
SOFT-START FUSE	115 VAC 12 AND 20 AMP	A-80552-007 (5 AMP) FUSE 121	1
SOFT START FUSE	ALL 230 VAC 12 and 20 AMP	A-80552-001 (10 AMP) FUSE 121	1
SOFT-START FUSE	ALL 50 AND 75 AMP	A-78896-017 (10 AMP) IN-LINE	1
REGEN FUSE	-112, 120	A-80552-013 (7 AMP) FUSE 132	1
REGEN FUSE	-112-02 -120-02	A-80552-001 (10 AMP) FUSE 132	1
REGEN FUSE	-212, 220	A-80552-009 (8 AMP) FUSE 132	1
REGEN FUSE	-212-01, -220-01	A-80552-002 (12 AMP) FUSE 132	1
REGEN FUSE	220-03	A-80552-003 (15 AMP) FUSE 132	1



ALL FUSES MUST BE REPLACED WITH EXACT SAME VALUE AND STYLE OR THEY WILL NOT BE EFFECTIVE.

6.3 ORDERING INSTRUCTIONS

If you need to order parts for the BDS4 and/or PSR4/5, you can order them through your local distributor. For a complete list of Industrial Drives representatives contact us directly at:

Danaher Motion Customer Support

201 Rock Road
Radford, VA 24141
U.S.A.

Telephone: 1-800-777-3786
(815) 226-3100
FAX: (540) 731-5641

APPENDIX A

WARRANTY INFORMATION

Industrial Drives, a Kollmorgen Division, warrants that equipment, delivered by it to the Purchaser, will be of the kind and quality described in the sales agreement and/or catalog and that the equipment will be free of defects in design, workmanship, and material.

The terms and conditions of this Warranty are provided with the product at the time of shipping or in advance upon request.

The items described in this manual are offered for sale at prices to be established by Industrial Drives and its authorized dealers.

APPENDIX B

MODEL NUMBERS

Table B.1. PSR4/5 Model Number Scheme

EXAMPLE:	PSR	4/5A-	2	50-	XX*	YY*
LEGEND:	A	B	C	D	E	F

LEGEND	DEFINITION
A	Power Supply with Regeneration (shunt regulation) and soft-start.
B	Power Supply generation indicator.
4/5	Standard Configuration. Used with BDS4 series servo motor amplifiers.
4/5V	Industrial Standard Configuration
4/5A	U.L. 508 listed Configuration. Used with BDS4A series servo motor amplifiers.
C	AC Line Voltage (L-L) RMS.
1	115 VAC, Single-Phase (not available for 50 and 75 amp models).
2	220 VAC, Single-Phase or 230 VAC, Three-Phase.
D	12,20,50,75 AC Line Current, RMS.
E	Mechanical Options.
00	Standard - No Option (all models have side cover)
01	Use "00" for new applications (previously with side cover).
70	Custom.
71	Custom.
72	Custom.
73	Custom.
80	Custom.
91	Special (12 and 20 amp PSR4/5 units only, with cover, without connector kit, 2 axes maximum).
F	Electrical Options.
00	Standard. No Options. 12 and 20 Amp models contain 40 Watt Internal Regeneration Resistor. 50 and 75 Amp Models require Regeneration Resistor Kit EX-2X (must be ordered separately).
01	8.8 Ohms, 400 Watt External Regen, 230 Volt, 12 and 20 Amp Models Only. Requires ER-01 External Resistor Kit.
02	5.5 Ohms, 200 Watt, 115 Volt External Regen, 12 and 20 Amp Models Only. Requires ER-02 External Resistor Kit.
03	5.8 Ohms, 700 Watt, 230 Volt External Regen, 12 and 20 Amp Models Only. Requires ER-03 External Resistor Kit.
20	Custom.
50	Without Soft-Start (50 and 75 Amp Models Only). Requires ER-2X External Resistor Kit.
70	Without Soft-Start and Regeneration (12 and 20 Amp Models Only).
80	Without Regeneration (12 and 20 Amp Models Only).
81	With 240 V logic supply unit, without regen, with soft-start.

*XXYY - Omit when there are no options.

Table B.2. ER-External Resistor Kit Model Number Scheme

EXAMPLE:	<u>ER-</u>	<u>01-</u>	<u>XX</u>
LEGEND:	A	B	C

LEGEND	DEFINITION
A	External Resistor Kit for PSR4/5.
B	Resistor Rating.
01	8.8 ohms, 400W, (12 or 20 amp, 230V models only).
02	5.5 ohms, 200W, (12 or 20 amp, 115V models only).
03	5.8 ohms, 700W, (12 or 20 amp, 230V models only).
20	4.5 ohms, 500W, (50 or 75 amp, 230V models only).
21	4.4 ohms, 1000W, (50 or 75 amp, 230V models only).
22	2.2 ohms, 1000W, (75 amp, 230V models only).
23	2.2 ohms, 2000W, (75 amp, 230V models only).
C	Options (None Available at this Printing).

Table B.3. BDS4 Model Number Scheme

EXAMPLE:	BDS	4A-	2	03	H	XX*	YY*	\	204A	Z
LEGEND:	A	B	C	D	E	F	G	H	I	

LEGEND	DEFINITION
A	Brushless Drive Sinewave Servo Amplifier.
B	Amplifier generation indicator. Original Standard Configuration (no letter designation). Industrial Standard Configuration. U.L. 508 listed configuration.
V	
A	
C	Maximum Output Voltage. 1 115VAC (Nominal). 2 230VAC (Nominal).
D	03, 06, 10, 20, 30, 40, 55 Output RMS Current Per Phase, Continuous.
E	R/D Converter. H Standard. Accuracy 22 Arc Min. Maximum. J Special. Accuracy 8 Arc Min. Maximum. Required for 01, 02, 03 Electrical Options or Motors with $N_{max} > 3$ KRPM.
F	Mechanical Options. 00 Standard Unit. No Options. 01 Side Cover Option. 02 Custom. 03 Custom. 70 Custom. 71 Custom. 73 Custom. 80 Custom. 91 Side Cover Option w/ Cover, No Conn. Kit
G	Electrical Options. 00 Standard Unit. No Options. 01 Electronic Encoder Output. Requires Type J R/D Converter. 02 Electronic Encoder with Parallel Output. Requires Type J R/D Converter. 03 Electronic Encoder with Parallel Output and Drive Signals Requires Type J R/D Converter. 05 Custom. 06 Custom. 07 Same as 01 Except Configured for LSB on Channel B. (Refer to Section E.2.2.1.) 08 14-Bit R/D with 3500 RPM Tracking Rate. Requires Type J R/D 09 Comp Card Without Components. 10 Custom. 11 Custom. 12 Custom. 13 Custom. 14 Same as 01 Plus 08. 15 Direction Limit Option Board. 16 14-Bit R/D with 2000 RPM Tracking Rate. Requires Type J R/D Converter.

Table B.3. BDS4 Model Number Scheme (Continued)

LEGEND	DEFINITION
17	14-Bit R/D with 3500 RPM "J" Grade, W Direction Limit Option.
18	Custom.
19	16 Bit R/D 600 RPM "J" Grade R/D.
81	Custom.
83	Custom.
84	Custom.
85	Custom.
91	Custom.
92	Custom.
93	Custom.
94	Custom.
95	Custom.
96	12-Bit R/D 14k RPM "J" Grade with encoder equivalent option.
H	Motor and Winding Designator.
I	Compensation Designator.
2	0 - 5 X Jm.
3	5 - 20 X Jm.
ZZ	Special.

*XXYY Omit when there are no options.

Table B.4. Compensation Card Model Designator

EXAMPLE:	<u>CMP-</u>	<u>BDS4-203H</u>	<u>204A2</u>
LEGEND:	A	B	C

LEGEND	DEFINITION
A	Compensation Card.
B	Amplifier Base Model Number.
C	Motor, Winding, and Compensation Designator.

B.1 CABLE, BUS WIRE, AND MATING CONNECTOR KIT INFORMATION

Extra or spare bus wire and complete cable assemblies are available from Industrial Drives.

Mating connector kits are available from Industrial Drives or may be purchased directly from the connector vendor.

B.2 CABLE MODEL NUMBER SCHEME FOR INDIVIDUAL CABLE SET

Motor cables are designed to provide reliable and cost-effective interconnection between Industrial Drives' Goldline Series Motors and any BDS Series Amplifier. GCS (Goldline Cable Set) models provide both motor (stator) and resolver (feedback) cable of equal length. Cables include motor mating plugs with various termination options at the amplifier end. There are 2 versions of the cable sets; the GCS and the GCSA. The GCS is used with motors that have MS Bayonet-type connectors, while the GCSA is used with motors that have MS screw-type connectors. To assist in ordering, the model number scheme for a cable set is as follows:

Table B.5. Cable Model Number Scheme for Individual Cable Set (Bayonet-Type Thread)

EXAMPLE:	GCS	-	M6A	/	R	-	4/5	-	03
LEGEND:	A		B		C		D		E

LEGEND	DEFINITION
A	Goldline Cable Set. Consists of one motor stator and one feedback cable with Bayonet type thread.
B	Motor Power Cable with mating plug for particular frame size.
M6A	B-60X-X-AX & BX Motors (up to 40 amps continuous).
M6B	B-60X-X-AX & BX Motors (up to 65 amps continuous).
M8A	B-80X-X-AX & BX Motors (up to 65 amps continuous).
M8B	B-80X-X-AX & BX Motors (up to 115 amps continuous).
C	Motor Feedback/Option Cable with Mating Plug.
R	System Resolver Only.
RBT	System Resolver, Brake, Tachometer.
D	Amplifier Termination.
4/5	BDS4 or BDS5, 3-20 Amp Models.
4/5H	BDS4 or BDS5, 30-55 Amp Models.
N	Not Terminated.
E	Cable Length to Motor. 3 to 75 Meters in 3-Meter Increments.

Table B.6. Cable Model Number Scheme for Individual Cable Set (Screw-Type Thread)

EXAMPLE:	<u>G</u> CSA -	<u>M</u> 4 /	<u>R</u> -	<u>4</u> / <u>5</u> -	<u>0</u> 3
LEGEND:	A	B	C	D	E

LEGEND	DEFINITION
A	Goldline Cable Set. Consists of one motor stator and one feedback cable with screw-type thread.
B	Motor Power Cable with mating plug for particular frame size.
M4B	B-40X-X-AX & BX Motors (up to 40 amps continuous).
M6A	B-60X-X-AX & BX Motors (up to 40 amps continuous).
M6B	B-60X-X-AX & BX Motors (up to 65 amps continuous).
M8A	B-80X-X-AX & BX Motors (up to 65 amps continuous).
M8B	B-80X-X-AX & BX Motors (up to 115 amps continuous).
C	Motor Feedback/Option Cable with Mating Plug.
R	System Resolver Only.
RBT	System Resolver, Brake, Tachometer.
D	Amplifier Termination.
4/5	BDS4 or BDS5, 3-20 Amp Models.
4/5H	BDS4 or BDS5, 30-55 Amp Models.
N	Not Terminated.
E	Cable Length to Motor. 3 to 75 Meters in 3-Meter Increments.

B.3. CABLE MODEL NUMBER SCHEME FOR INDIVIDUAL CABLE

Individual cables can be provided by GC (Goldline Cable) Models. To assist in ordering, the model number scheme for an individual cable is as follows:

Table B.7. Cable Model Number Scheme for Individual Cable (Bayonet-Type Connector)

EXAMPLE:	GC -	M2 -	4/5 -	03
LEGEND:	A	B	C	D

LEGEND	DEFINITION
A	Goldline Cable With Bayonet-Type Connector (individual cable).
B	Motor Power Cable with Mating Plug or Feedback/Option Cable.
M1	B-10X Motors.
M2	B-20X Motors.
M4	B-40X Motors.
M6A	B-60X-X-AX & BX Motors (up to 40 amps continuous).
M6B	B-60X-X-AX & BX Motors (up to 65 amps continuous).
M8A	B-80X-X-AX & BX Motors (up to 65 amps continuous).
M8B	B-80X-X-AX & BX Motors (up to 115 amps continuous).
R	System Resolver Only.
RBT	System Resolver, Brake, Tachometer.
AR	Application Resolver.
C	Amplifier Termination.
4/5	BDS4 or BDS5, 3-20A Models.
4/5H	BDS4 or BDS5, High Current Models.
N	Not Terminated.
D	Cable Length to Motor. 3 to 75 Meters in 3-Meter Increments.

Table B.8. Cable Model Number Scheme for Individual Cable (Screw-Type Connector)

EXAMPLE:	<u>GCA</u> -	<u>M4</u> -	<u>4/5</u> -	<u>03</u>
LEGEND:	A	B	C	D

LEGEND	DEFINITION
A	Goldline Cable with screw-type connector (individual cable).
B	Motor Power Cable with Mating Plug or Feedback/Option Cable.
M4	B-40X Motors (up to 40 amps continuous).
M6A	B-60X Motors (up to 40 amps continuous).
M6B	B-60X Motors (up to 65 amps continuous).
M8A	B-80X Motors (up to 65 amps continuous).
M8B	B-80X Motors (up to 115 amps continuous).
R	System Resolver Only.
RBT	System Resolver, Brake, Tachometer.
AR	Application Resolver.
C	Amplifier Termination.
4/5	BDS4 or BDS5, 3 to 20 A Models.
4/5H	BDS4 or BDS5, High Current Models.
N	Not Terminated.
D	Cable Length to Motor. 3 to 75 Meters in 3-Meter Increments.

B.4 SPECIAL CABLES FOR RESOLVER FEEDBACK AND INTERFACE

The GC specials are designed to eliminate the need for the customer to make crimp connections for BDS4 input/output connector (C1) and BDS4 resolver connector (C2). These cables are terminated at C1 and C2 on the BDS4 and are unterminated at the opposite end. The unterminated end is intended to be connected into a customer-supplied terminal block. To assist in ordering, the model number schemes for these special cables are as follows:

Table B.9. Resolver Feedback Cables

GC-RF-4/5-XX	Resolver feedback flying lead cable (not terminated at the motor). XX-length in 3 meter increments; 03, 09, etc.
GC-IOF-4-XX	I/O flying lead cable (not terminated at customer's interface). XX-length in 3 meter increments; 03, 09, etc.

B.5 SPECIAL CABLES FOR LOGIC POWER SUPPLY

Special logic power supply cables are available to accommodate the various physical sizes of BDS4 and PSR4/5 modules and are designed based on standard module spacing requirements. Refer to drawing B-84929 for information concerning decoding the model numbers of special logic bus cables. To assist in ordering, the model number scheme for this cable is:

GC-LOGIC-XXXXXXX

A

PPENDIX C

CONNECTOR KITS & TOOLS

C.1 INTRODUCTION

Mating connectors are customer furnished items which may be ordered either from Industrial Drives or purchased directly from the connector vendor. Ordering information is as follows:

Table C.1. Connector Kit BDS4C-100

INDUSTRIAL DRIVES CONNECTOR KIT -- PART NUMBER----BDS4C-100			
BDS4 - 3, 6 and 10 AMP MODELS			
CONNECTOR	DESCRIPTION	MOLEX PART NO.	I.D. PART NO.
C1	Connector Housing, 20 Position Female	39-01-2205	A-83908-020
C2	Connector Housing, 12 Position Female	39-01-2125	A-83908-012
C3	Connector Housing, 8 Position Female	39-01-2085	A-83908-008
C1, C2, C3	PIN, Female, (18-24 AWG)	39-00-0039	A-83909-002

Table C.2. Connector Kit BDS4C-101

INDUSTRIAL DRIVES CONNECTOR KIT -- PART NUMBER----BDS4C-101			
BDS4 - 20 AMP MODELS			
CONNECTOR	DESCRIPTION	MOLEX PART NO.	I.D. PART NO.
C1	Connector Housing, 20 Position Female	39-01-2205	A-83908-020
C2	Connector Housing, 12 Position Female	39-01-2125	A-83908-012
C3	Connector Housing, 8 Position Female	39-01-2085	A-83908-008
C4	Connector Housing, 4 Position Male	39-01-2045	A-83908-004
C1, C2, C3, C4	PIN, Female, (18-24 AWG)	39-00-0039	A-83909-002

Table C.3. Connector Kit BDS4C-200

INDUSTRIAL DRIVES CONNECTOR KIT -- PART NUMBER----BDS4C-200			
BDS4 - 30, 40, and 55 AMP MODELS			
CONNECTOR	DESCRIPTION	MOLEX PART NO.	I.D. PART NO.
C1	Connector Housing, 20 Position Female	39-01-2205	A-83908-020
C2	Connector Housing, 12 Position Female	39-01-2125	A-83908-012
C3	Connector Housing, 8 Position Female	39-01-2085	A-83908-008
C4	Connector Housing, 4 Position Male	39-01-2045	A-83908-004
C1, C2, C3, C4	PIN, Female, (18-24 AWG)	39-00-0039	A-93105-002

Table C.4. Connector Kit PSR4/5C-200

INDUSTRIAL DRIVES CONNECTOR KIT -- PART NUMBER----PSR4/5C-200			
PSR4/5 - 12, 20, 50 and 75 AMP MODELS			
CONNECTOR	DESCRIPTION	MOLEX PART NO.	I.D. PART NO.
C1	Connector Housing, 6 Position Female	39-01-2065	A-83908-006
C2	Connector Housing, 8 Position Female	39-01-2085	A-83908-008
C1, C2	PIN, Female (18-24 AWG)	39-00-0039	A-83909-002

Table C.5. Connector Tools

CONNECTOR TOOLS (PINS, MINI FIT JR.) FROM MOLEX		
Description	Engineering Number	Order Number
Hand Crimping Tool	HTR-60622	11-01-0197
Extractor Tool	HT-60630A	11-03-0038
MOLEX TELEPHONE NUMBER: (708) 969-4550		

APPENDIX D

SPECIFICATIONS

D.1 INTRODUCTION

The Specifications for the PSR4/5 and BDS4 are provided in this appendix. Derating information is also included for environments with high ambient

temperatures. As a general rule, the failure rate of solid state components doubles for every ten degrees Celsius rise in temperature. This exponential failure rate is strong incentive for lower ambient temperatures.

Table D.1. PSR4/5 Specifications

DESCRIPTION	PSR4/5-112	PSR4/5-120
Main AC Line Input Voltage	90 - 160 VAC	90 - 160 VAC
Phase	1 Phase	1 Phase
Frequency	47 - 63 HZ	47 - 63 HZ
Current RMS/Phase, Continuous	12 AMPS	20 AMPS
Current RMS/Phase, Peak (2 Sec.)	24 AMPS	40 AMPS
Current RMS/Phase, Peak (50 msec.)	50 AMPS	80 AMPS
Control AC Line Input Voltage	95 - 132 VAC	95 - 132 VAC
Phase	1 Phase	1 Phase
Frequency	47 - 63 HZ	47 - 63 HZ
Current RMS	1.5 AMPS	1.5 AMPS
Output Power	1.0 K WATTS	1.7 K WATTS
Volts	140 VDC	140 VDC
Unregulated Logic Bus Output		
<u>No Load</u>	± 26 VDC MAX + 14 VDC MAX	
<u>Full Load</u>	± 14.5 VDC MIN. @ 1 AMPS + 6.5 VDC MIN. @ 2 AMPS	
Internal Shunt Regulator, Peak Current	30 A	30 A
Internal Shunt Regulator, Resistance	7.5 OHM	7.5 OHM
Internal Shunt Regulator, Resistor Power	40 WATTS	40 WATTS
External Shunt Regulator, Peak Current	50 A	50 A
External Shunt Regulator, Min. Resistance	5.5 OHM	5.5 OHM
External Shunt Regulator, Resistor Power	Model Dependant	Model Dependant
Internal Power Dissipation, Continuous (Less Shunt Regulator)	60 W	90 W
Soft-Start Surge Current (MAX)	35 AMPS	35 AMPS
Soft-Start Charge Time (MAX)	0.25 SEC.	0.25 SEC.

Table D.1. PSR4/5 Specifications (Con't)

DESCRIPTION	PSR4/5-212	PSR4/5-220
Main AC Line Input Voltage	207 - 253 VAC	207 - 253 VAC
Phase	3 Phase	3 Phase
Frequency	47 - 63 HZ	47 - 63 HZ
Current RMS/Phase, Continuous	12 AMPS	20 AMPS
Current RMS/Phase, Peak (2 Sec.)	24 AMPS	40 AMPS
Current RMS/Phase, Peak (50 msec.)	48 AMPS	80 AMPS
Control AC Line Input Voltage	95 - 132 VAC	95 - 132 VAC
Phase	1 Phase	1 Phase
Frequency	47 - 63 HZ	47 - 63 HZ
Current RMS	1.5 AMPS	1.5 AMPS
Output Power	3.6 K WATTS	6.0 K WATTS
Volts	310 VDC	310 VDC
Unregulated Logic Bus Output <u>No Load</u>	± 26 VDC MAX + 14 VDC MAX	
<u>Full Load</u>	± 14.5 VDC MIN. @ 1 AMPS + 6.5 VDC MIN. @ 2 AMP	
Internal Shunt Regulator, Peak Current	32 A	32 A
Internal Shunt Regulator, Resistance	12.5 OHM	12.5 OHM
Internal Shunt Regulator, Resistor Power	40 WATTS	40 WATTS
External Shunt Regulator, Peak Current *	50 A	50 A
External Shunt Regulator, Min. Resistance *	8.8 OHMS	8.8 OHMS
External Shunt Regulator, Resistor Power	Model Dependant	Model Dependant
Internal Power Dissipation, Continuous (Less Shunt Regulator)	60 W	90 W
Soft-Start Surge Current (MAX)	80 AMPS	80 AMPS
Soft-Start Charge Time (MAX)	0.25 SEC.	0.25 SEC.

* The -XX03 Electrical Option version has a peak regulator current of 75 amps, a minimum resistance of 5.8 ohms, and a power rating of 700 watts.

Table D.1. PSR4/5 Specifications (Con't)

DESCRIPTION	PSR4/5-250	PSR4/5-275
Main AC Line Input Voltage	207 - 253 VAC	207 - 253 VAC
Phase	3 Phase	3 Phase
Frequency	47 - 63 HZ	47 - 63 HZ
Current RMS/Phase, Continuous	50 AMPS	75 AMPS
Current RMS/Phase, Peak (2 Sec.)	75 AMPS	112 AMPS
Current RMS/Phase, Peak (50 msec.)	100 AMPS	150 AMPS
Control AC Line Input Voltage	95 - 132 VAC	95 - 132 VAC
Phase	1 Phase	1 Phase
Frequency	47 - 63 HZ	47 - 63 HZ
Current RMS	3.0 AMPS	3.0 AMPS
Output Power	15 K WATTS	22.5 K WATTS
Volts	310 VDC	310 VDC
Unregulated Logic Bus Output <u>No Load</u>	± 26 VDC MAX + 14 VDC MAX	
<u>Full Load</u>	± 14.5 VDC MIN. @ 2 AMPS + 6.5 VDC MIN. @ 4 AMPS	
Shunt Regulator, Peak Current	100 A	200 A
Shunt Regulator, Min. Resistance	4.3 OHM	2.15 OHM
Internal Power Dissipation, Continuous (Less Shunt Regulator)	175 W	250 W
Internal Power Dissipation, Peak (2 SEC.)	325 W	475 W
Soft-Start Surge Current (MAX)	40 AMPS	40 AMPS
Soft-Start Charge Time (MAX)	0.5 SEC.	0.5 SEC.

Table D.2. BDS4 Specifications

DESCRIPTION	BDS4-103X	BDS4-106X	BDS4-110X	BDS4-120X
MAIN DC BUS Minimum Maximum	125 VDC 225 VDC	125 VDC 225 VDC	125 VDC 225 VDC	125 VDC 225 VDC
Unregulated Logic Bus Input	± 14.5-26 VDC @ 0.25 AMPS	± 14.5-26 VDC @ 0.25 AMPS	± 14.5-26 VDC @ 0.25 AMPS	± 14.5-26 VDC @ 0.25 AMPS
	+ 6.5-14 VDC @ 0.50 AMPS	+ 6.5-14 VDC @ 0.50 AMPS	+ 6.5-14 VDC @ 0.50 AMPS	+ 6.5-14 VDC @ 0.50 AMPS
Fan AC Line Input	---	---	---	95-132 VAC 50/60 HZ @ 0.5 AMPS
Output Current (RMS/PHASE) Convection Cooled (45° C AMB) Continuous (RMS) Peak (2.0 SEC.) (RMS)	3.0 AMPS 6.0 AMPS	6.0 AMPS 12.0 AMPS	10.0 AMPS 20.0 AMPS	(Fan Cooled) 20.0 AMPS 40.0 AMPS
Output KVA (@ 160 VDC BUS) Continuous (45°C AMB) Peak (2.0 SEC.)	0.5 KVA	1.0 KVA	1.7 KVA	3.3 KVA
	1.0 KVA	2.0 KVA	3.3 KVA	6.7 KVA
Internal Heat Dissipation	30 WATTS	50 WATTS	75 WATTS	135 WATTS
PWM Switching Frequency	10.0 KHZ	10.0 KHZ	10.0 KHZ	10.0 KHZ
Motor Current Ripple Frequency ± 10%	20.0 KHZ	20.0 KHZ	20.0 KHZ	20.0 KHZ
Resolver Excitation Frequency	7.0 KHZ	7.0 KHZ	7.0 KHZ	7.0 KHZ
Form Factor RMS/AVG	≤ 1.01	≤ 1.01	≤ 1.01	≤ 1.01
Speed Regulation (Long Term)	0.075%/°C	0.075%/°C	0.075%/°C	0.075%/°C
†Minimum Controllable Speed: Standard 12-Bit R/D With 8000 RPM Max. Tracking Rate	2.0 RPM	2.0 RPM	2.0 RPM	2.0 RPM
12-Bit R/D With 14000 RPM Max. Tracking Rate	3.5 RPM	3.5 RPM	3.5 RPM	3.5 RPM
14-Bit R/D With 2000 RPM Max. Tracking Rate	1/8 RPM	1/8 RPM	1/8 RPM	1/8 RPM
14-Bit R/D With 3500 RPM Max. Tracking Rate	1/4 RPM	1/4 RPM	1/4 RPM	1/4 RPM
16-Bit R/D With 500 RPM Max. Tracking Rate	1/64 RPM	1/64 RPM	1/64 RPM	1/64 RPM

† Minimum controlled speed is defined as the minimum speed that can readily be run. The standard BDS4 is configured with a 12-bit R/D converter for a maximum motor speed of 8,000 RPM. Other resolutions and maximum motor speeds (tracking rates) must be ordered as specials.

Table D.2. BDS4 Specifications (Con't)

DESCRIPTION	BDS4-203X	BDS4-206X	BDS4-210X	BDS4-220X
MAIN DC BUS Minimum Maximum	250 VDC 360 VDC	250 VDC 360 VDC	250 VDC 360 VDC	250 VDC 360 VDC
Unregulated Logic Bus Input	± 14.5-26 VDC @ 0.25 AMPS	± 14.5-26 VDC @ 0.25 AMPS	± 14.5-26 VDC @ 0.25 AMPS	± 14.5-26 VDC @ 0.25 AMPS
	+ 6.5-14 VDC @ 0.50 AMPS	+ 6.5-14 VDC @ 0.50 AMPS	+ 6.5-14 VDC @ 0.50 AMPS	+ 6.5-14 VDC @ 0.50 AMPS
Fan AC Line Input	---	---	---	95-132 VAC 50/60 HZ @ 0.5 AMPS
Output Current (RMS/PHASE) Convection Cooled (45° C AMB) Continuous (RMS) Peak (2.0 SEC.) (RMS)	3.0 AMPS 6.0 AMPS	6.0 AMPS 12.0 AMPS	10.0 AMPS 20.0 AMPS	(Fan Cooled) 20.0 AMPS 40.0 AMPS
Output KVA (@330 VDC BUS) Continuous (45°C AMB) Peak (2.0 SEC.)	1.1 KVA	2.2 KVA	3.6 KVA	7.3 KVA
	2.2 KVA	4.4 KVA	7.3 KVA	14.5 KVA
Internal Heat Dissipation	40 WATTS	65 WATTS	95 WATTS	175 WATTS
PWM Switching Frequency	10.0 KHZ	10.0 KHZ	10.0 KHZ	10.0 KHZ
Motor Current Ripple Frequency ± 10%	20.0 KHZ	20.0 KHZ	20.0 KHZ	20.0 KHZ
Resolver Excitation Frequency	7.0 KHZ	7.0 KHZ	7.0 KHZ	7.0 KHZ
Form Factor RMS/AVG	≤ 1.01	≤ 1.01	≤ 1.01	≤ 1.01
Speed Regulation (Long Term)	0.075%/°C	0.075%/°C	0.075%/°C	0.075%/°C
†Minimum Controllable Speed:				
Standard 12-Bit R/D With 8000 RPM Max. Tracking Rate	2.0 RPM	2.0 RPM	2.0 RPM	2.0 RPM
12-Bit R/D With 14000 RPM Max. Tracking Rate	3.5 RPM	3.5 RPM	3.5 RPM	3.5 RPM
14-Bit R/D With 2000 RPM Max. Tracking Rate	1/8 RPM	1/8 RPM	1/8 RPM	1/8 RPM
14-Bit R/D With 3500 RPM Max. Tracking Rate	1/4 RPM	1/4 RPM	1/4 RPM	1/4 RPM
16-Bit R/D With 500 RPM Max. Tracking Rate	1/64 RPM	1/64 RPM	1/64 RPM	1/64 RPM

Table D.2. BDS4 Specifications (Con't)

DESCRIPTION	BDS4-230X	BDS4-240X	BDS4-255X
MAIN DC BUS Minimum Maximum	250 VDC 360 VDC	250 VDC 360 VDC	250 VDC 360 VDC
Unregulated Logic Bus Input	± 14.5-26 VDC @ 0.25 AMPS	± 14.5-26 VDC @ 0.25 AMPS	± 14.5-26 VDC @ 0.25 AMPS
	+ 6.5-14 VDC @ 0.50 AMPS	+ 6.5-14 VDC @ 0.50 AMPS	+ 6.5-14 VDC @ 0.50 AMPS
Fan AC Line Input	95 - 132 VAC @ 0.5 AMPS	95 - 132 VAC @ 0.5 AMPS	95 - 132 VAC @ 0.75 AMPS
Output Current (RMS/PHASE) (45° C AMB) Continuous (RMS) Peak (2.0 SEC.)	(FAN COOLED) 30 AMPS 60 AMPS	(FAN COOLED) 40 AMPS 80 AMPS	(FAN COOLED) 55.0 AMPS 110 AMPS
Output KVA (@ 330 VDC BUS) Continuous (45°C AMB) Peak (2.0 SEC.)	11.0 KVA 22.0 KVA	14.5 KVA 29 KVA	20 KVA 40 KVA
Internal Heat Dissipation	255 WATTS	335 WATTS	445 WATTS
PWM Switching Frequency	10.0 KHZ	10.0 KHZ	10.0 KHZ
Motor Current Ripple Frequency ± 10%	20.0 KHZ	20.0 KHZ	20.0 KHZ
Resolver Excitation Frequency	7.0 KHZ	7.0 KHZ	7.0 KHZ
Form Factor RMS/AVG	≤ 1.01	≤ 1.01	≤ 1.01
Speed Regulation (Long Term)	0.075%/°C	0.075%/°C	0.075%/°C
†Minimum Controllable Speed:			
Standard 12-Bit R/D With 8000 RPM Max. Tracking Rate	2.0 RPM	2.0 RPM	2.0 RPM
12-Bit R/D With 14000 RPM Max. Tracking Rate	3.5 RPM	3.5 RPM	3.5 RPM
14-Bit R/D With 2000 RPM Max. Tracking Rate	1/8 RPM	1/8 RPM	1/8 RPM
14-Bit R/D With 3500 RPM Max. Tracking Rate	1/4 RPM	1/4 RPM	1/4 RPM
16-Bit R/D With 500 RPM Max. Tracking Rate	1/64 RPM	1/64 RPM	1/64 RPM

† Minimum controlled speed is defined as the minimum speed that can readily be run. The standard BDS4 is configured with a 12-bit R/D converter for a maximum motor speed of 8,000 RPM. Other resolutions and maximum motor speeds (tracking rates) must be ordered as specials.

Table D.3. Derating Data

Derating Information (Continuous Duty)			
BDS4	60HZ Derating @55° C*	50HZ Operation In 45° Max. Ambient	50HZ % Total Derating @ 55°C
3 A	20%	No Derating	20%
6 A	20%	No Derating	20%
10 A	20%	No Derating	20%
20 A	20%	No Derating	20%
30 A	20%	20%	36%
40 A	20%	20%	36%
55 A	20%	20%	36%

PSR4/5 Logic Bus Supply	60HZ Derating @55° C*	50HZ Operation In 45° Max. Ambient	50HZ % Total Derating @ 55°C
12A	10%	No Derating	10%
20A	10%	No Derating	10%
50A	10%	No Derating	10%
75A	10%	No Derating	10%

PSR4/5 Main Bus Supply	60HZ Derating @55° C*	50HZ Operation In 45° Max. Ambient	50HZ % Total Derating @ 55°C
12A	No Derating	20%	20%
20A	No Derating	20%	20%
50A	10%	10%	20%
75A	10%	10%	20%

* Based on Derating of 2% /° C from 45° C to 55° C. Consult Factory for Derating Above 55° C.

Table D.4. Environmental Specifications

Operating Temperature	0° C to 45° C
Storage Temperature	-20° C to 70° C
Humidity (Non-Condensing)	10% to 90%

Table D.5. Mechanical Specifications

MODEL NUMBER	WIDTH		HEIGHT		DEPTH		WEIGHT	
	MM	IN.	MM	IN.	MM	IN.	Kg(f)	LB.
BDS4-X03X-	60	2.3	340	13.5	280	11	2.95	6 1/2
BDS4-X06X-	60	2.3	340	13.5	280	11	3.40	7 1/2
BDS4-X10X-	88	3.5	340	13.5	280	11	6.01	13 1/4
BDS4-X20X-	106	4.2	340	13.5	280	11	6.35	14
BDS4-230X-	140	5.5	340	13.5	284	11.2	9.75	21 1/2
BDS4-240X-	140	5.5	340	13.5	284	11.2	9.98	22
BDS4-255X-	160	6.3	340	13.5	284	11.2	10.43	23
PSR4/5-X12-	80	3.1	340	13.5	280	11	4.76	10 1/2
PSR4/5-X20-	80	3.1	340	13.5	280	11	5.44	12
PSR4/5-X50-	140	5.5	340	13.5	284	11.2	12.02	26 1/2
PSR4/5-X75-	140	5.5	340	13.5	284	11.2	12.25	27

APPENDIX E

OPTIONS

Options are brought into existence from time to time to satisfy specific needs and to add versatility to the product. (Refer to the Model Number Schemes in Appendix B.)

The BDS4 and PSR4/5 may be ordered with various mechanical and electrical options, standard or custom designed for particular applications. If a feature is desired which is not covered here, consult the Industrial Drives Sales Staff for information on custom designed options.

E.1 PSR4/5A/V ELECTRICAL OPTIONS

12 and 20 AMP Models:

OPTION:

- 01 400 watts external regeneration resistor kit for 230V systems (refer to Section 4.7).
- 02 200 watts external regeneration resistor kit for 115V systems (refer to Section 4.7).
- 03 700 watts external regeneration resistor kit for 230V systems (refer to Section 4.7).
- 80 without Regen or dynamic brake
- 81 with 240 V logic supply, without Regen or dynamic brake

50 and 75 AMP Models:

OPTION:

- 20 with undervolt fault
- 50 without soft-start circuitry.

E.2 BDS4 ELECTRICAL OPTIONS

The standard BDS4 servo amplifier is fitted with a 12-bit R/D converter which allows a maximum tracking rate of 8000 RPM and a maximum operating speed of 7500 RPM.

The BDS4 amplifiers are available with standard options which are discussed in the following sections. These options are either integrated into the main circuit board of the BDS4 amplifier or appear as Option Boards that are mounted inside of the BDS4 chassis.

E.2.1 Integrated Options

R/D Converter Resolution and Tracking Rate Options:

Optional R/D resolutions and tracking rates are available and produce higher resolution position information and/or better low-speed performance. These options are integrated into the main circuit board (motor control board) within the BDS4 amplifier and are as follows:

Option - 08 contains a 14-bit R/D, produces a maximum tracking rate of 3500 RPM, and a maximum operating speed of 3200 RPM.

Option - 11 contains a 16-bit R/D, produces a maximum tracking rate of 500 RPM, and a maximum operating speed of 450 RPM.

Option - 16 contains a 14-bit R/D, produces a maximum tracking rate of 2000 RPM, and a maximum operating speed of 1800 RPM.

Accuracies, repeatability, and resolution specifications are recorded in the tables located in Section E.2.2.4.

E.2.2 BDS4-OPT2/3A Option Board

The option board can support 10-, 12- 14-, or 16-bit R/D converters (mounted within the BDS4). The card may be configured one of three ways:

- 01- as a differential quadrature encoder interface with marker pulse.
- 02- as a 12- to 16-bit buffered parallel resolver data interface.
- 03- as a 12- to 16-bit buffered parallel resolver data interface with drive control signals.

E.2.2.1 BDS4-OPT2/3A-01 BOARD Electronic Encoder Output

When configured as a BDS4-OPT2/3A-01 board, only the encoder outputs are offered. The board functions only to convert the binary (motor shaft) position information from the R/D (Resolver-to-Digital) converter, located within the BDS4 amplifier, to differential quadrature encoder signals with marker pulse.

The output interface connections are made via Connector 32, mounted on the BDS4-OPT2/3A-01 Board. This connector is an 8-Pin Molex MINI-FIT JR connector and is located just to the left of Connector C1 mounted in the top front of the BDS4 amplifier .

The pin outs are as follows:

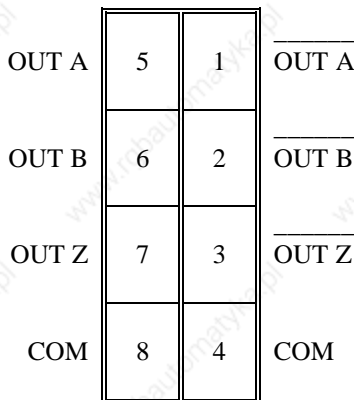

Figure E.1. Connector 32

The encoder interface option provides a differential quadrature synthesized encoder output and a

differential marker pulse output for customer use. Each output pair (OUT A or A phase, OUT B or B phase, and OUT Z or Z phase) is driven by a DS8830/SN75183 differential line driver integrated circuit. The voltage levels transition between + 5 volts and common. This interface is capable of sinking and sourcing 40 milliamps of current. The differential outputs are designed to drive long lengths of coaxial cable, strip line, or twisted pair transmission lines with characteristic impedances of 50 to 500 ohms.

The quadrature signal is generated by the following sequence:

Refer to Drawing D-93179-1.

Up to sixteen parallel resolver data bits are brought to the BDS4-OPT2/3A Option Board via connectors 7 and 33. These bits first pass through LS244 data buffers. Next the data bits are routed to a double row jumper/header (component 35). At this header the quadrature resolution is selected by manipulating two jumpers. The resolution can be from 16 to 16384 encoder lines in increments of power of two (2^x) (i.e., 16, 32, 64, 128, 256, 512, 1024, 2048, 4096, 8192, 16384). The following jumper table shows the jumper combinations for the resolutions available. After two of the twelve data bits have been selected at the jumper/header block (Component 35) by the two jumper selections, these two signals are routed to a pair of Exclusive-Or gates. This is where the quadrature (A Phase offset from B Phase by 90 degrees) signal pair are generated.

After this the two quadrature signals are latched by a pair of LS175 flip-flops. The non-inverting output from each flip-flop drives an LED. The inverting output from each flip-flop drives a pair of DS8830 or 75183 line drivers. The line driver outputs route straight across a jumper/header strip (this is used with other options) and terminate at customer Connector 32.

The marker pulse signal is generated by the following sequence:

All sixteen parallel resolver data bits are brought to the BDS4-OPT2/3A Option Board. These bits first pass through LS244 data buffers. Next the data bits are routed to a bank of DIP switches consisting of Components 23 and 26. At these switches the marker pulse width is selected. For a minimum pulse width all switches should be closed. As more switches are

opened from the LSB to the MSB, the pulse width will become wider. The marker pulse width selected has no effect on the quadrature resolution selected although these two types of signals are normally related on a standard encoder. The jumper/switch table that follows shows the wide and narrow marker pulse selection with each of the eleven encoder equivalent resolutions available. After the dip switch, the selected signals are **Anded** together then **Anded** with all of the MSB data lines that were not switch-selectable. Note that the combination of the two Nand gates feeding into an Or gate results in the equivalent of a large Nand gate. The output of the Or gate feeds into a LS175 flip-flop. The non-inverting output of the flip-flop drives an LED. The inverting output of the flip-flop drives a DS8830 or 75183 line driver. The line driver outputs route straight across a jumper/header strip (this is used with other options) and terminate at customer Connector 32.

The encoder resolution (OUT A and OUT B) can be jumpered for resolutions between 16 to 16384 lines in binary (2^X) increments. The OUT Z (Marker Pulse) can be switch-selected for either a narrow pulse width or a wide pulse width in relation to the particular resolution selected. Note that any other marker pulse width can be selected as it has no direct effect on the selected resolution of the encoder equivalent signal.

STANDARD 12-BIT CONFIGURATION

Place two jumpers on header #35:

JUMPER PINS I-J
JUMPER PINS K-L

Adjust the Dip Switch #23 & #36 to:

SWITCH A - OFF
SWITCH B - OFF
SWITCH C - OFF
SWITCH D - OFF
SWITCH E - OFF
SWITCH F - ON
SWITCH G - ON
SWITCH H - ON
SWITCH I - ON
SWITCH J - ON
SWITCH K - ON
SWITCH L - ON

Double Row Header #28:

JUMPER 1-2

JUMPER 3-4
JUMPER 5-6
JUMPER 7-8
JUMPER 9-10
JUMPER 11-12

See Schematic Drawing D-93179

E.2.2.2 BDS4-OPT2/3A-02 BOARD

Electronic Encoder with Parallel Output (Without Drive Signals)

The parallel resolver data option provides 12 - 16 bits of buffered resolver data output. The signals are output on one 34-pin ribbon cable connector. The mating connector for the ribbon cable connector is a Berg P/N 66900-234 or equivalent. The ribbon cable pinouts are listed in Table E.2 and on drawing C-93185.



NOTE

POS00-POS15 are sequenced to agree with PMC-960 positioner board signal names for a 12-bit configuration. Due to this, POS12-POS15 will appear to be out of sequence.

E.2.2.3 BDS4-OPT2/3A-03 BOARD

Electronic Encoder with Parallel Output (With Drive Signals)

This option is similar to that discussed in Section E.2.2.2 with the exception that it also provides for a means by which the Industrial Drives' 960 position controller can interface directly with the BDS4 motor controller. This is accomplished by adding a small cable between Connector 32 on the BDS4 OPT2/3A board and Connector C1 of the BDS4 amplifier. The BDS4 motor controller signals are identified in the above table by the addition of an asterisk by the pin numbers. Connector 37 on the BDS4-OPT2/3A board is located just to the left of Connector C1 mounted in the top front of the BDS4.

E.2.2.4 BDS4 AND BDS4-OPT2/3A (BOARD) SYSTEM SPECIFICATIONS

Accuracies, repeatability, and resolution specifications are recorded in Table E.3.

E.3 BDS4-OPT-D/L OPTION BOARD

- Function:

The BDS4-OPT-D/L option board functions as an interface module between the BDS4 and machine travel limit switches. There are separate inputs for the CW and CCW directions of motor shaft rotation (viewing the motor from the output shaft end). In the event a machine limit switch is activated, the motor will decelerate (at maximum rate) to zero speed and remain against the "stop" in a reduced current mode. The BDS4 will remain fully operational with full current and torque available for movement in the opposite direction (provided the opposite limit switch is not activated).

- Wiring

Reference to Drawing A-93541 will assist in wiring the D/L option board. The speed command (position error) to the BDS4 amplifier must be wired to 1 and 4 of the special differential input terminals on the D/L option board, **NOT TO THE STANDARD INPUT OF THE BDS4**. In order to initiate restricted movement the customer must provide 5 to 28 VDC, through limit switches on the machine, to the CW and CCW inputs of the D/L option board. The 5 to 28 VDC supply must be capable of sourcing 20 ma of current.

- Board Configuration:

The D/L option board is shipped from the factory configured so that the absence of input (5 to 28 VDC) from either of its CW or CCW inputs activate the direction limit mode. If it is desired that direction limit be activated by the presence of voltage, remove Jumper 26 located between Pins 2 and 3 on the board and install it between Pins 1 and 2.

- Direction Limit Indication:

When the Direction Limit mode is activated, a red LED will become illuminated. The LED is located just behind option board Connector 3 and can be seen through the opening in the front of the BDS4.

- Adjustments:

There is only one adjustment on the D/L option board. It is the Command Scale Pot, and is located next to option board Connector 67.

Perform the adjustment procedure in the following manner:

1. Adjust the Command Scale pot in the front of the BDS4 fully CCW.
2. Adjust the Command Scale pot on the D/L option board in the standard manner by referring to Section 4.4.1.3 or 4.4.1.4 of this manual.

Table E.2. OPT2/3A-02 and OPT2/3A-03 Pinouts

CONNECTOR #4		
*1	ICMD	DIFF HI (current/velocity command) (analog)
*2	ACOM	DIFF LOW (connected to analog common)
*3	TACH	TACH HI (analog signal)
*4	ACOM	TACH LOW (connected to analog common)
5	ALOCK	ANALOG LOCK HI (analog signal)
6	ACOM	ANALOG LOCK LOW (analog common)
*7	DRVENB'	Servo Drive Enable (active low)
8	DCOM	Digital Common
*9	DRVRDY'	Servo Drive Ready (active low)
10	DCOM	Digital Common
11	BUSY	Resolver's R-to-D Converter Busy (active high)
12	DCOM	Digital Common
13	N/C	Reserved
14	DCOM	Digital Common
15	POSO0	Least Significant Bit for 12-Bit R/D
16	DCOM	Digital Common
17	POSO1	Next to Least Significant Bit for 12-Bit R/D
18	DCOM	Digital Common
19	POSO2	One Input Bit of Resolver
20	POSO3	One Input Bit of Resolver
21	POSO4	One Input Bit of Resolver
22	POSO5	One Input Bit of Resolver
23	POSO6	One Input Bit of Resolver
24	POSO7	One Input Bit of Resolver
25	POSO8	One Input Bit of Resolver
26	POSO9	One Input Bit of Resolver
27	POS10	Next to Most Significant Bit of the Resolver
28	POS11	Most Significant Bit of the Resolver
29	POS12**	Next to Least Significant Bit for 14-Bit R/D
30	POS13**	Least Significant Bit for 14-Bit R/D
31	POS14**	Next to Least Significant Bit for 16-Bit R/D
32	POS15**	Least Significant Bit for 16-Bit R/D
33	N/C	Reserved
34	SHIELD	EMI Isolated Shield Common

* These signals are only available on the OPT2/3A-03 option.

** These signals are not available on all models of the BDS4.

Table E.3. System Specifications

ACCURACIES	J GRADE R/D	H GRADE R/D
R/D CONVERTER ACCY	± 4.0 ARC MIN	± 22.0 ARC MIN
RESOLVER ACCY	± 7.0 ARC MIN	± 7.0 ARC MIN
RESOLVER MOUNTING	± 3.0 ARC MIN	± 3.0 ARC MIN
UNCERTAINTY** (± 1 Count)	± 5.27 ARC MIN	± 5.27 ARC MIN
WORST CASE ACCY*	19.27 ARC MIN	37.27 ARC MIN
	0.32 DEGREES	0.62 DEGREES
	± 1.8 BITS	± 3.5 BITS
TYPICAL ACCY	13.87 ARC MIN	28.55 ARC MIN
	0.22 DEGREES	0.48 DEGREES
	± 1.3 BITS	± 2.5 BITS
REPEATABILITY	5.27 ARC MIN	5.27 ARC MIN
	0.088 DEGREES	0.088 DEGREES
	1.0 BIT	1.0 BIT
RESOLUTION	2 ¹² BITS (4096)	2 ¹² BITS (4096)

* Worst Case Analysis assumes all errors add together.

** For 12-bit systems only. For 14-bit systems, the uncertainty drops to ± 1.32 arc min and for 16-bit systems, the uncertainty drops to ± 0.33 arc min. Therefore, the worst case and typical accuracies will be reduced slightly for 14- and 16-bit systems.

Table E.4. R/D Converter Speeds

R/D CONVERTER MAXIMUM SPEED			MAXIMUM OPERATING SPEED
R/D RESOLUTION	TRACKING RATE		
12-Bit	233.33 RPS	8000 RPM	7500
12-Bit	133.33 RPS	8000 RPM	7500
14-Bit	58.33 RPS	3500 RPM	3150
14-Bit	33.33 RPS	2000 RPM	1800
16-Bit	15.0 RPS	900 RPM	800
16-Bit	13.33 RPS	500 RPM	450

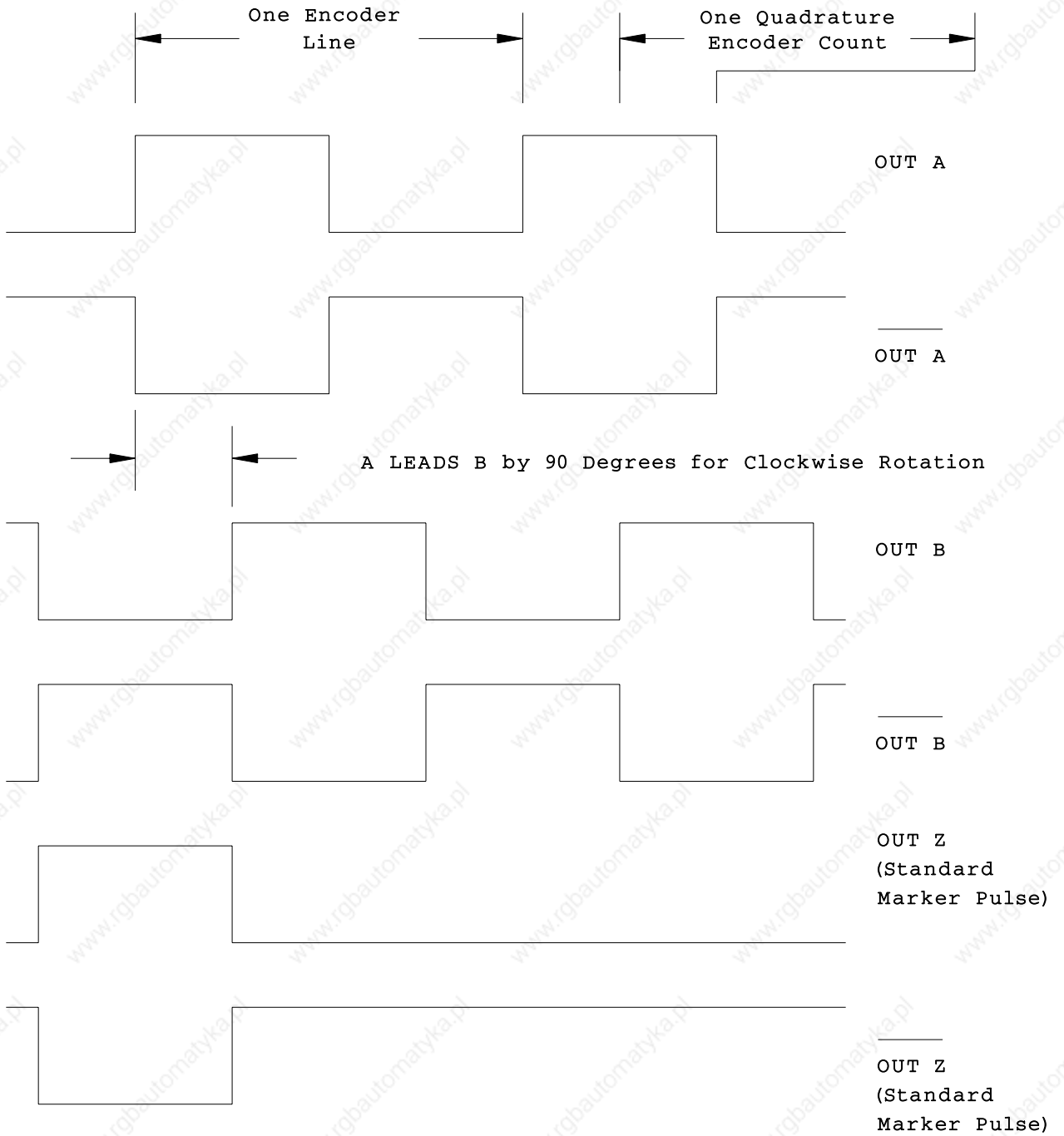

Figure E.2. Encoder Output Timing

APPENDIX F

DRAWINGS

DRAWING

A-63542.....	Motor Connection
A-83908.....	Purchase Spec. for Mini-Fit, Jr.Series Connector
A-83909.....	Purchase Spec. for Mini-Fit, Jr.Series Terminals
A-84385.....	Outline & Dimension PSR4/5 - 12 & 20 Amp
A-93031.....	Outline & Dimension PSR4/5 - 50 & 75 Amp
A-93092.....	PRS4/5 50A / 75A (with & without Soft Start) Simplified Schematic
A-93112.....	Outline & Dimension BDS4 - 55 Amp
A-93141.....	Wiring & Mounting DiagramER-20
A-93156.....	Outline & Dimension BDS4 - 30 & 40 Amp
A-93231.....	BDS4 Wiring Diagram
A-93314.....	Wiring & Mounting Diagram ER-21
A-93315.....	Wiring & Mounting Diagram ER-22
A-93316.....	Wiring & Mounting Diagram ER-23
A-93369.....	GOLDLINE Amplifier Assembly Guide for Resolver Cables
A-93408.....	PRS4/5 12A / 20A Simplified Schematic
A-93409.....	PSR4/5 Internal Schematic
A-93414.....	GOLDLINE Amplifier Assembly Guide for Motor Cables (30, 40, & 55 Amp)
A-93421.....	GOLDLINE Amplifier Assembly Guide for Motor Cables (3 thru 20 Amp)
A-93538.....	GOLDLINE Amplifier Assembly Guide for Motor Cables (3 thru 20 Amp)
A-93539.....	GOLDLINE Amplifier Assembly Guide for Motor Cables (30, 40, & 55 Amp)
A-93540.....	GOLDLINE Amplifier Assembly Guide for Resolver Cables
A-93541.....	BDS4 Direction Limit Wiring Diagram
A-93567.....	Outline & Dimension BDS4 - 3 & 6 Amp
A-93568.....	Outline & Dimension BDS4 - 20 Amp
A-93572.....	Outline and Dimension BDS4 - 10 Amp
A-93656.....	Mounting Hole Pattern BDS4, BDS5, PSR4/5
A-93700.....	DC Bus Cable Assembly for BDS4/5 & PSR4/5
A-93703.....	Mounting Hole Pattern BDS4
B-84929.....	BDS4 & BDS5 Logic Cable Assembly
C-84113.....	BDS4 Simplified Schematic
C-84723.....	PSR4/5 Simplified Schematic
C-84724.....	PSR4/5 Internal Schematic
C-93185.....	BDS4 - OPT2/3A Pinout Options
D-93179.....	BDS4 - OPT2/3A

UNLESS OTHERWISE SPECIFIED
ANG. DIM. ±1 DEGREE

XX DEC. PLACES ±.015 IN.
XXX DEC. PLACES ±.005 IN.

DO NOT SCALE DWG. USE DIMENSIONS ONLY.
ALL DIMENSIONS ARE INCHES UNLESS OTHERWISE SPECIFIED

DWG. NO.
A-63542

ISSUE
3

PHASE A (BROWN LEAD) - PIN "A"
PHASE B (RED LEAD) - PIN "B"
PHASE C (WHITE LEAD) - PIN "C"
CASE GROUND (GREEN w/
YELLOW STRIPE LEAD) - PIN "D"

MOTOR LEAD CONNECTIONS

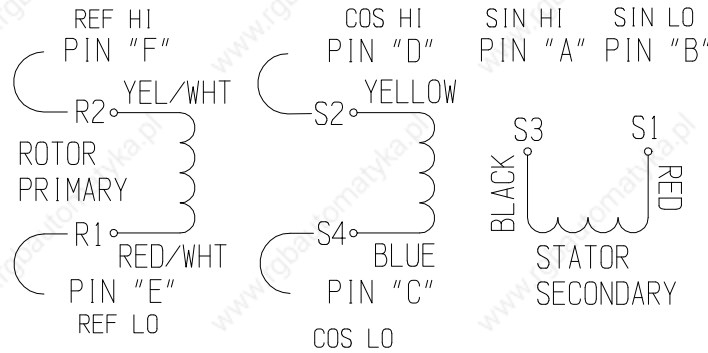

RESOLVER CONNECTION DIAGRAM

THERMOSTAT (BLACK LEADS) - PINS "T" & "U"
TACH (BLACK LEAD) - PIN "R"
(WHITE LEAD) - PIN "S"
BRAKE (BLUE LEADS) - PINS "N" & "P"

THERMOSTAT, TACH & BRAKE CONNECTIONS
(LOCATED IN RESOLVER CABLE ASSEMBLY)

F2

NOTES:

- 1 - WITH A PHASE SEQUENCE A, C, B MOTOR ROTATION SHALL BE C.W. FACING MOUNTING END.
- 2 - THERMOSTAT PRESET TO OPEN AT 170°C ±5°C AND CLOSE AT 132°C ±5°C, NORMALLY CLOSED, CONTACTS RATED TO 4 AMPS, 120 V.A.C.
- 3 - OPTIONAL TACH - WITH ROTATION PER NOTE #1, A POSITIVE VOLTAGE IS GENERATED ON PIN "R" WITH RESPECT TO PIN "S".

COPY CODE			
ISS.	ECN NO.	DATE	APP'D.

ISS.	ECN NO.	DATE	APP'D.
2	85244 LLS	05-17-93	
3	85550 DAC	12-20-93	

Kollmorgen Industrial Drives
RADFORD, VIRGINIA

DWN. BY:	DATE	CHK. BY:	DATE	APP'D. BY:	DATE
TDG	11-03-92			CJF	11-09-92

SCALE	DWG. NO.	ISSUE
1 : 1	A-63542	3

CAD DWG.

MOTOR
CONNECTION

NOTES

- 1.) USE PIN # A-83909 - - - - WITH THIS CONNECTOR.
- 2.) MATERIAL: UL 94V-0 NYLON

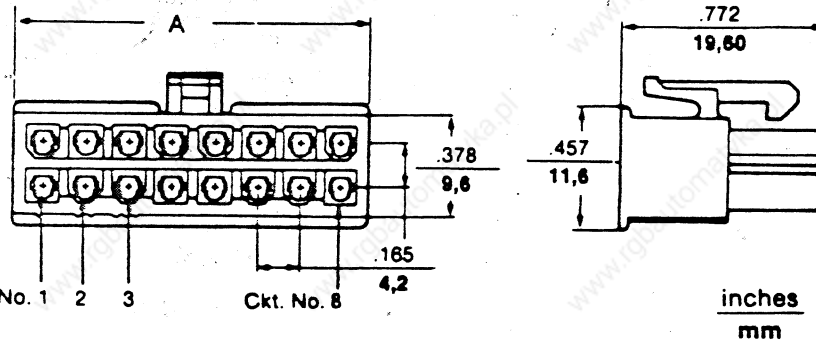

DASH NO.	Circuits	Dim. A	Dim. B	Dim. C
002	2	.213 5,4	—	.606 15,4
004	4	.378 9,6	.165 4,2	.772 19,6
006	6	.543 13,8	.331 8,4	.937 23,8
008	8	.709 18,0	.496 12,6	1.102 28,0
010	10	.874 22,2	.661 16,8	1.268 32,2
012	12	1.039 26,4	.827 21,0	1.433 36,4
014	14	1.205 30,6	.992 25,2	1.598 40,6
016	16	1.370 34,8	1.157 29,4	1.764 44,8
018	18	1.535 39,0	1.323 33,6	1.928 49,0
020	20	1.701 43,2	1.488 37,8	2.094 53,2
022	22	1.866 47,4	1.654 42,0	2.60 57,4
024	24	2.031 51,6	1.819 46,2	2.425 61,6

NUMBER OF CIRCUITS

APPROVED VENDOR: MOLEX # (39-01-2-5)

S N B COPY CODE

Kollmorgen Industrial Drives
RADFORD, VIRGINIA

PURCHASE SPEC. FOR
MINI-FIT, JR. SERIES CONNECTOR

UNLESS OTHERWISE SPECIFIED
XX DEC PLACES ± .015
XXX DEC PLACES ± .005
ANG DIM ± 1°

DO NOT SCALE DWG USE DIMENSIONS ONLY
ALL DIMENSIONS ARE INCHES
UNLESS OTHERWISE SPECIFIED

ISS	ECN NO	DATE	APP'D	ISS	ECN NO	DATE	APP'D	DW'N BY	DATE
								V.A.	11/29/88
								CHK BY	
								APP'D BY	12-6-88

SCALE:

DWG NO **A-83908** ISSUE **1**

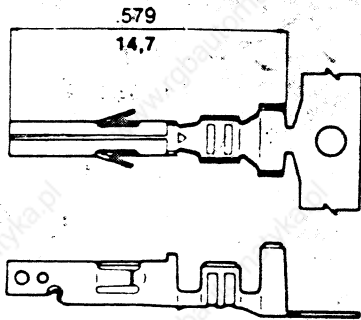

inches
mm

DASH NO.	PART NO.	Wire Size	Insulation Diameter	Plating	FORM
-001	5556 Female 39-00-0078	AWG #16	.071" - .122" (1,8mm-3,1mm)		LOOSE
-002	39-00-0038 • 39-00-0039	AWG #18-24	.051"-.118" (1,3mm-3mm)	Tin Plated Brass	CHAIN LOOSE
-003	• 39-00-0047	AWG #22-28	.035"-.071" (0,9-1,8mm)		LOOSE
-004	39-00-0080	AWG #16	.071" - .122" (1,8mm-3,1mm)	Tin Plated Phosphor Bronze	
-005	• 39-00-0060	AWG #18-24	.051"-.118" (1,3mm-3mm)		
-006	39-00-0090	AWG #16	.071" - .122" (1,8mm-3,1mm)		
-007	39-00-0056	AWG #18-24	.051"-.118" (1,3mm-3mm)	30 microinches Gold Plated Brass	
-008	39-00-0085	AWG #22-28	.035"-.071" (0,9-1,8mm)		

2

3

APPROVED VENDOR: MOLEX

S N B COPY CODE

Kollmorgen Industrial Drives

RADFORD, VIRGINIA

UNLESS OTHERWISE SPECIFIED
XX DEC PLACES .015
XXX DEC PLACES .005
ANG DIM ± .1"

DO NOT SCALE DWG USE DIMENSIONS ONLY
ALL DIMENSIONS ARE INCHES
UNLESS OTHERWISE SPECIFIED

ISS	ECN NO	DATE	APP'D	ISS	ECN NO	DATE	APP'D	DW'N BY	DATE
2	83689	8-23-90	CAF	3	301304	5/6/98	CAF	V.A.	11-29-88
					TLH			CHK BY	
								APP'D BY	12-6-88

PURCHASE SPEC. FOR
MINI-FIT, JR SERIES TERMINALS

SCALE:

DWG. NO

ISSUE

A-83909

3

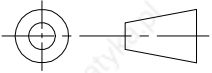

UNLESS OTHERWISE SPECIFIED
ANG. DIM. ±1 DEGREE

METRIC
X DEC. PLACES ±.4
XX DEC. PLACES ±.13

[INCHES]
XX DEC. PLACES ±.015 IN.
XXX DEC. PLACES ±.005 IN.

DO NOT SCALE DWG. USE DIMENSIONS ONLY.
ALL DIMENSIONS ARE MILLIMETERS WITH INCHES
IN BRACKETS. UNLESS OTHERWISE SPECIFIED.

DWG. NO.
A-93031

ISSUE
8

THIRD ANGLE PROJECTION
METRIC

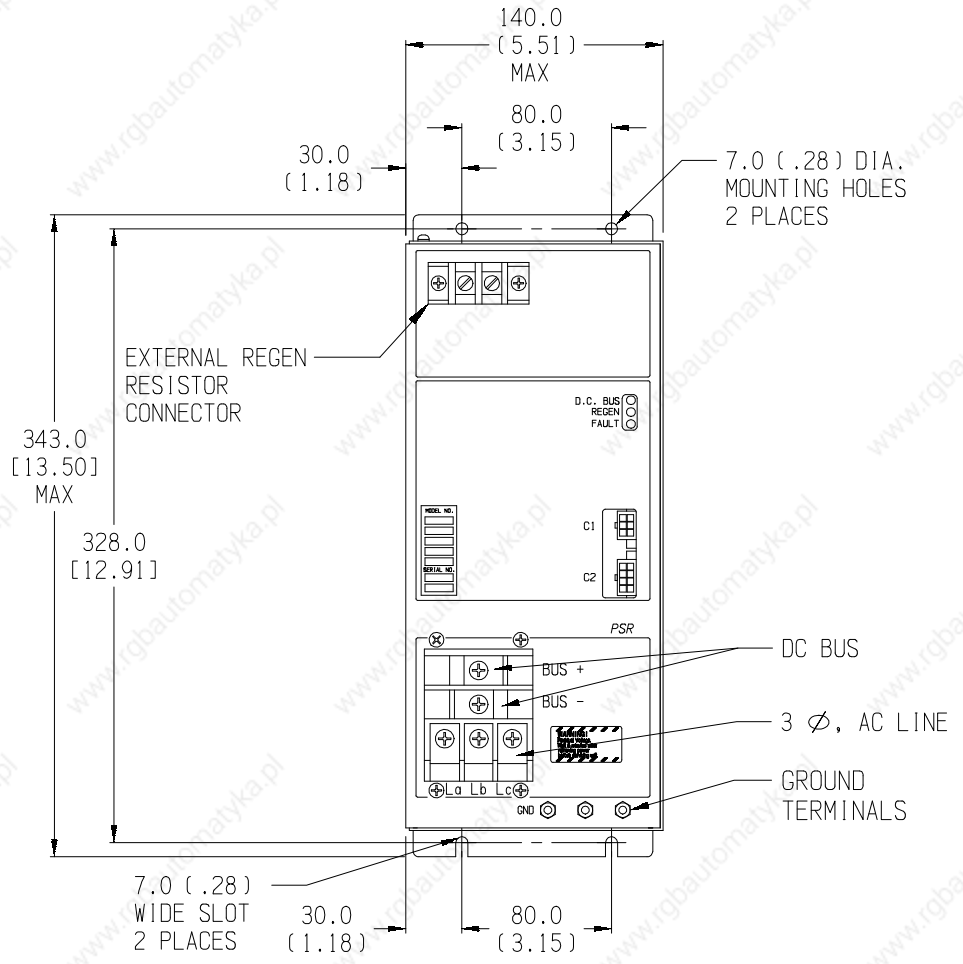
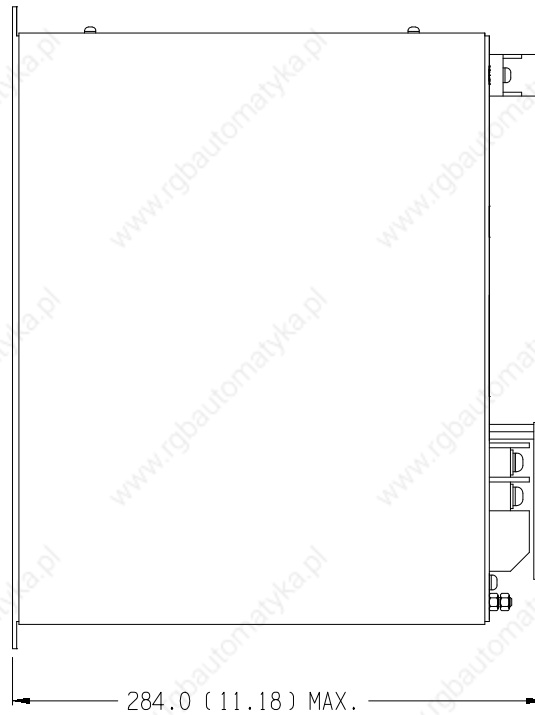
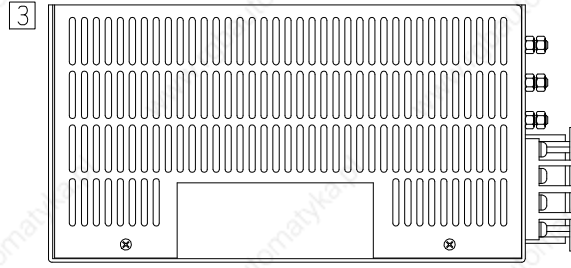

ISS.	ECN NO.	DATE	APP'D.	ISS.	ECN NO.	DATE	APP'D.
7	86885 JMM	6-2-95	SCM	2	84111 EWR	08-05-91	CJF
8	87736 RRH	8-01-96		3	85645 LLS	02-22-94	CJF
				4	85945 AWL	07-06-94	CJF
				5	86426 TDC	01-06-95	SCM
				6	86530 TDC	02-13-95	

Kollmorgen Industrial Drives
RADFORD, VIRGINIA

OUTLINE & DIMENSION
PSR4/5X-50, 75, 90 AMP

DWN. BY:	DATE	CHK. BY:	DATE	APP'D. BY:	DATE
V. A.	01-09-91	FDO	03-19-91	MP	03-19-91

SCALE	DWG. NO.	ISSUE
1:4	A-93031	8

CAD DWG

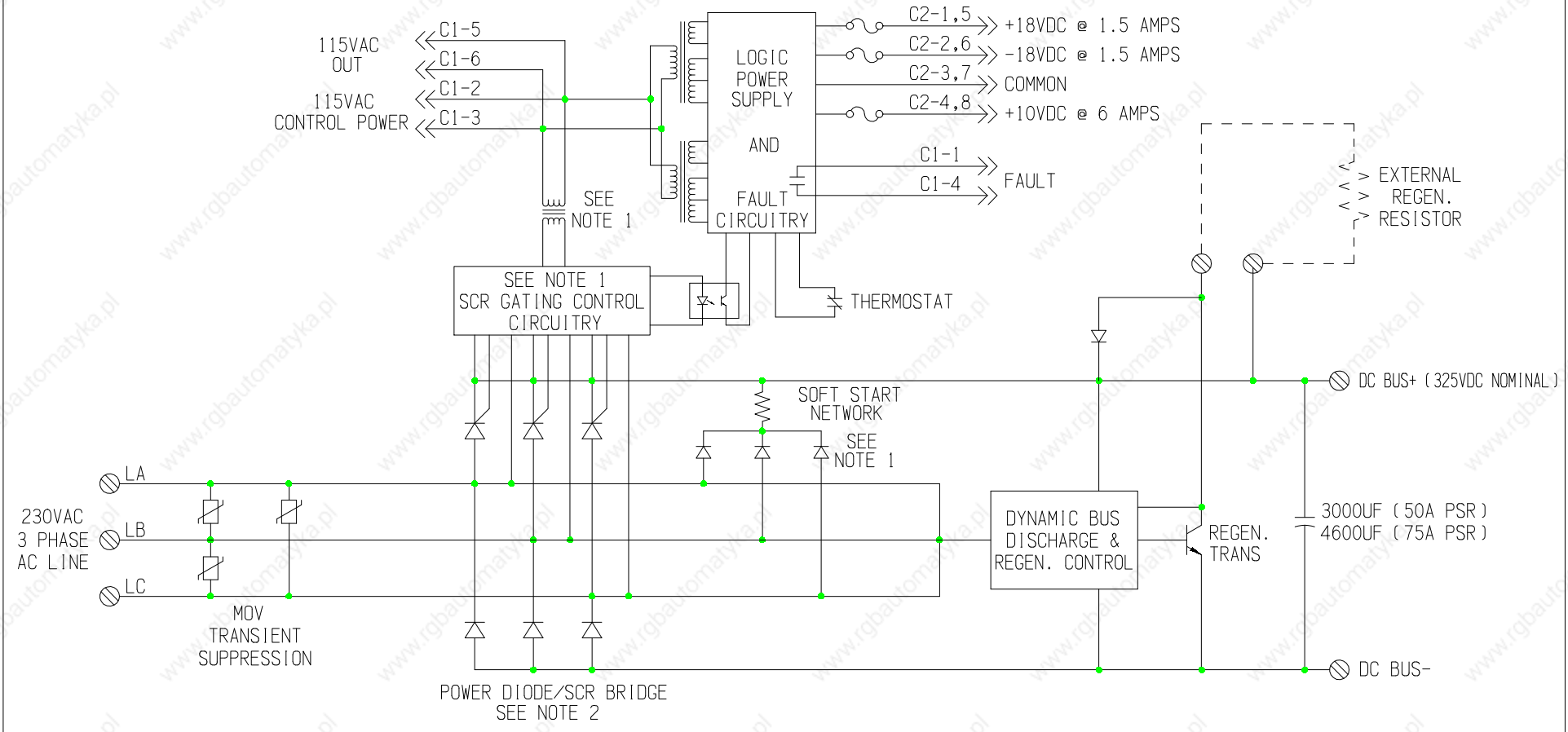

NOTES:
 1. OMIT ON VERSION WITHOUT SOFT START.
 2. SCRS ARE REPLACED WITH DIODES ON VERSION WITHOUT SOFT START.

CAD DWG. (D-38)

S		COPY CODE		ISS.	ECN NO.	DATE	APP'D.	 INDUSTRIAL DRIVES RADFORD, VIRGINIA A KOLLMORGEN DIVISION			PRS4/5 50A/75A (WITH & WITHOUT SOFT START) SIMPLIFIED SCHEMATIC					
ISS.	ECN NO.	DATE	APP'D.								DWN. BY:	DATE	CHK. BY:	DATE	APP'D. BY:	DATE
								TG	3-4-91	FDO	3-19-91	MP	3-19-91	1:2	A-93092	1

UNLESS OTHERWISE SPECIFIED
ANG. DIM. $\pm 1^\circ$

(METRIC)
X DEC. PLACES $\pm .4$
XX DEC. PLACES $\pm .13$

(INCHES)
XX DEC. PLACES $\pm .015$ IN.
XXX DEC. PLACES $\pm .005$ IN.

DO NOT SCALE DWG. USE DIMENSIONS ONLY.
ALL DIMENSIONS ARE MILLIMETERS WITH INCHES
IN PARENTHESES. UNLESS OTHERWISE SPECIFIED.

DWG. NO.

A-93112

ISSUE

3

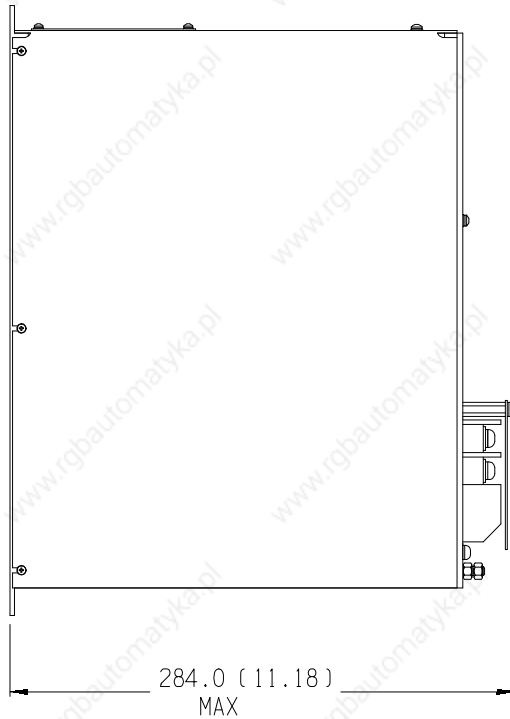
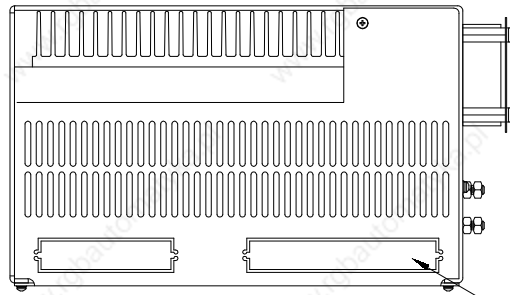

POSSIBLE OPTION
BOARD CONNECTOR(S)

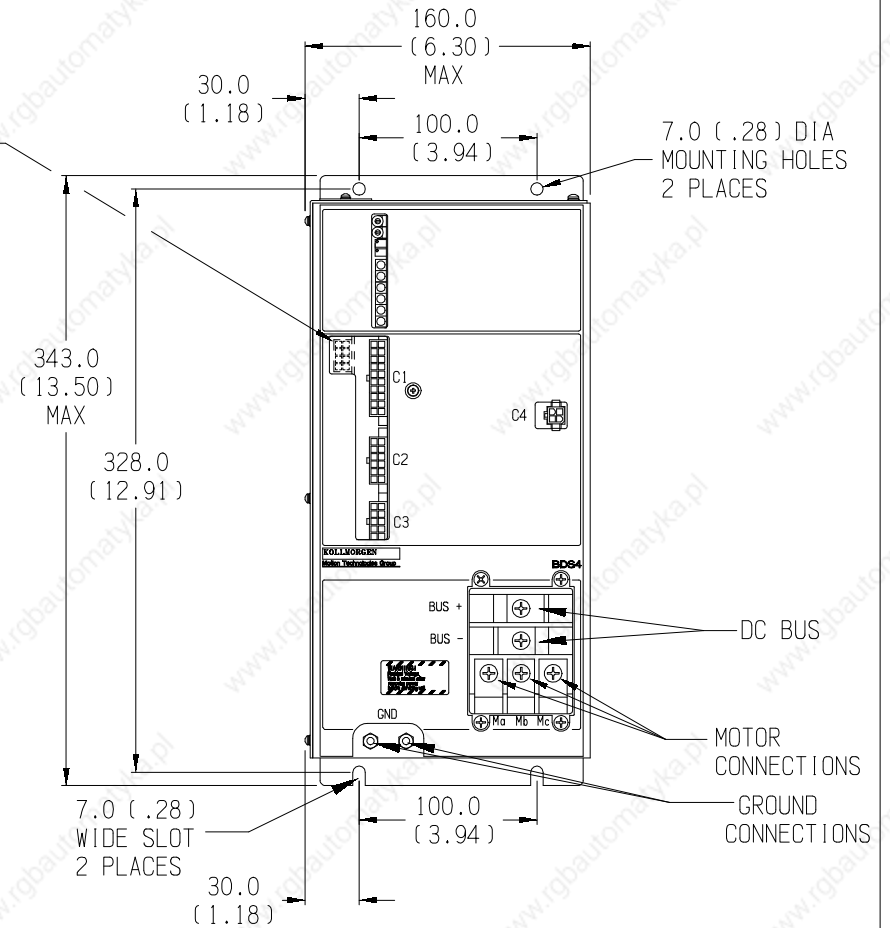

THIS UNIT CONTAINS STATIC SENSITIVE MATERIAL, HANDLE ACCORDINGLY.

CAD DWG.

ISS.		COPY CODE		ISS.	ECN NO.	DATE	APP'D.	Kollmorgen Industrial Drives RADFORD, VIRGINIA				OUTLINE & DIMENSION BDS4-55 AMP					
ISS.	ECN NO.	DATE	APP'D.									DWN. BY:	DATE	CHK. BY:	DATE	APP'D. BY:	DATE
				2	84919 TDG	1-7-93	CJF										
				3	87736 RRH	7-11-96		EWR	07-12-91			CJF	7-17-91	1:4	A-93112	3	

1/4-20 x 1/2 PAN HD. SCREW, QTY(2)
 1/4 LOCKWASHER, QTY(2)
 1/4 FLATWASHER, .75" O.D., QTY(2)
 STANDOFF, SPRUCE PINE # 2165-1B, QTY(2)

500W CONTINUOUS
 4.5 OHM RESISTOR
 QTY(1) 1.750 DIA.

SET TRIP CURRENT
 TO: 10.5 A [2] [3]

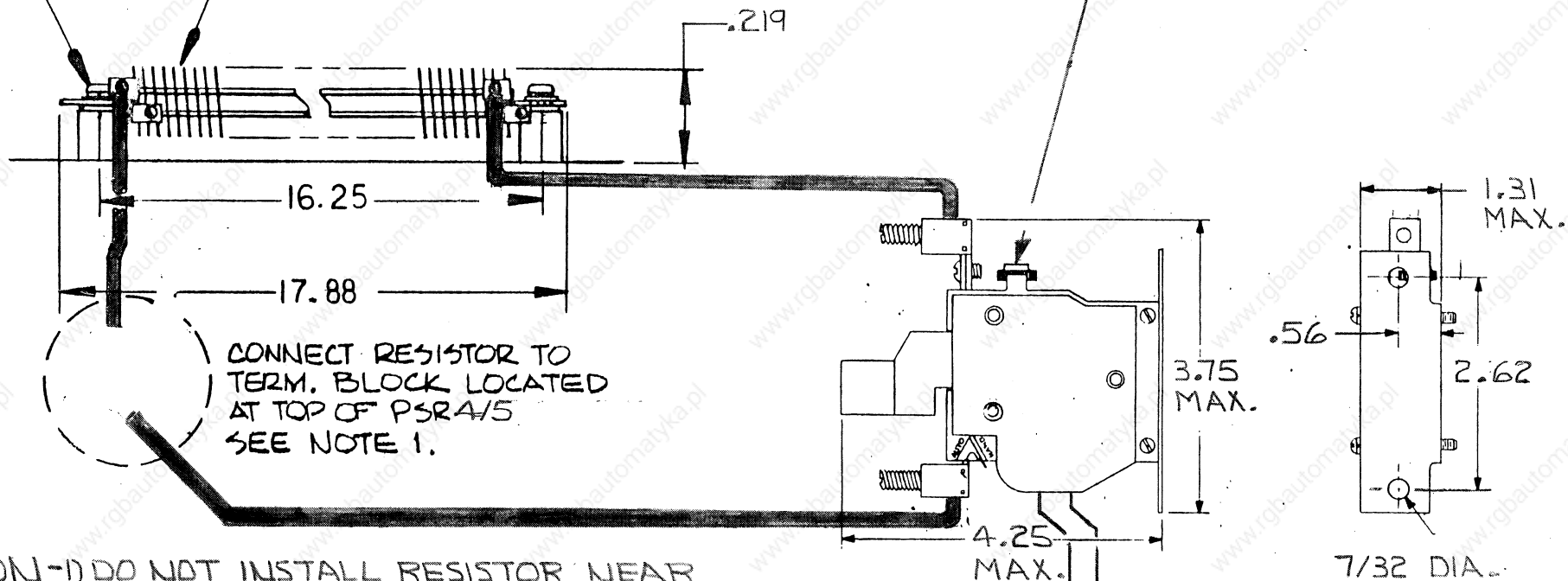

SEE NOTE # 3

7/32 DIA. 2 MOUNT. HOLES

SKB COPY CODE

Kollmorgen Industrial Drives
 RADFORD, VIRGINIA

WIRING & MOUNTING DIAG.
 ER-20

SCALE: — DWG. NO. **A-93141** ISSUE **3**

CAUTION-1) DO NOT INSTALL RESISTOR NEAR FLAMMABLE MATERIAL.
 NOTES: 2) SHOCK HAZARD & RESISTOR CONNECTED TO HIGH VOLTAGE.
 1. RECOMMENDED WIRE: # 8AWG, 125°C
 2. BOTTOM STANDOFFS ARE THREADED 1/4-20 x 3/8" DP FOR MOUNTING RESISTORS TO PANELS, ETC.
 3. OUTPUT CONTACTS: WIRED TO DROP MAIN LINES WHEN CONTACTS OPEN ON OVERLOAD.

UNLESS OTHERWISE SPECIFIED
 XX DEC. PLACES ±.015
 XXX DEC. PLACES ±.005
 ANG. DIM. ± 1°

DO NOT SCALE DWG. USE DIMENSIONS ONLY
 ALL DIMENSIONS ARE INCHES
 UNLESS OTHERWISE SPECIFIED

ISS.	ECN NO.	DATE	APP'D	ISS.	ECN NO.	DATE	APP'D	DW'N BY	DATE
				2	83926 OWENS	5/29/91	CF	OWENS	1-10-91
				3	84007 GEARHEART	5/21/91	CF		
								APP'D BY CF	1-15-91

UNLESS OTHERWISE SPECIFIED
ANG. DIM. $\pm 1^\circ$

(METRIC)
X DEC. PLACES $\pm .4$
XX DEC. PLACES $\pm .13$

(INCHES)
XX DEC. PLACES $\pm .015$ IN.
XXX DEC. PLACES $\pm .005$ IN.

DO NOT SCALE DWG. USE DIMENSIONS ONLY.
ALL DIMENSIONS ARE MILLIMETERS WITH INCHES
IN PARENTHESES. UNLESS OTHERWISE SPECIFIED.

DWG. NO.
A-93156

ISSUE
4

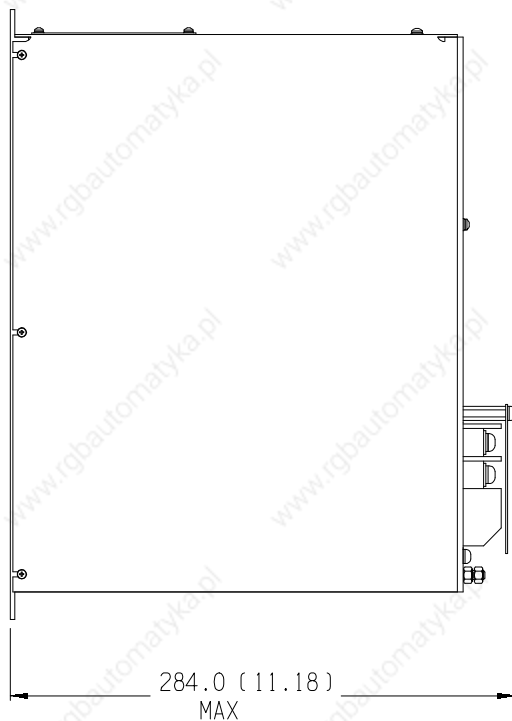
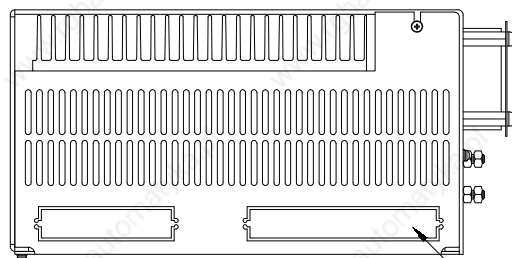

POSSIBLE OPTION
BOARD CONNECTOR(S)

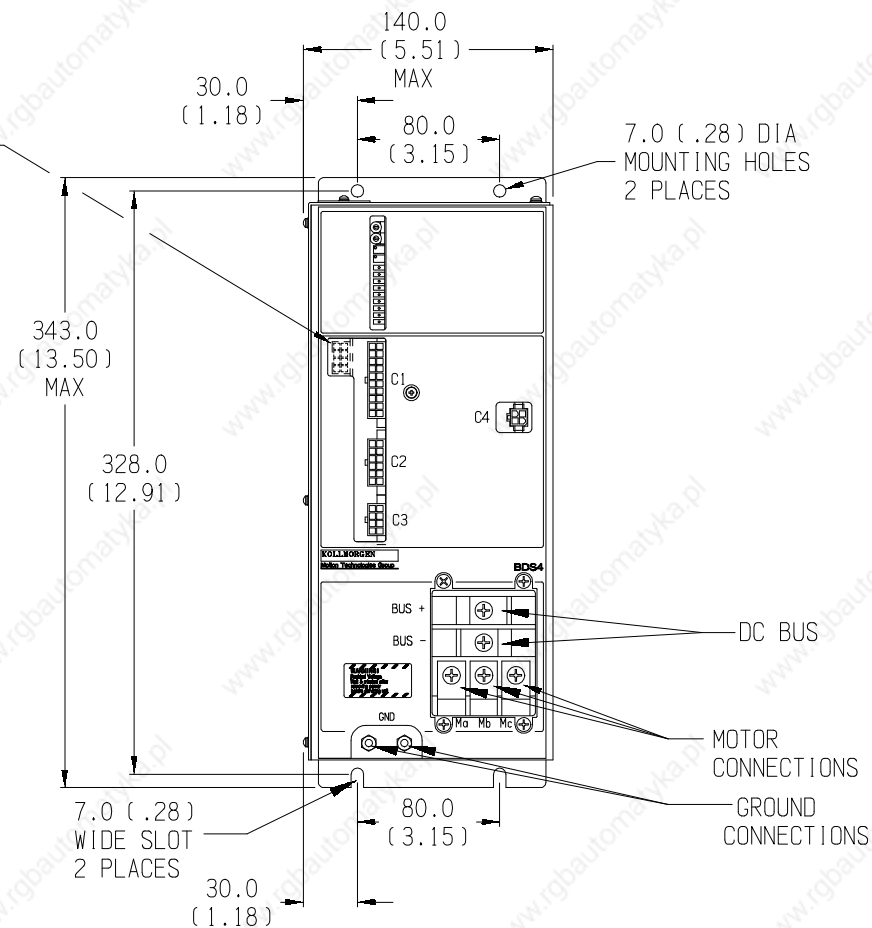

THIS UNIT CONTAINS STATIC SENSITIVE MATERIAL, HANDLE ACCORDINGLY.

CAD DWG.

COPY CODE				ISS.	ECN NO.	DATE	APP'D.	Kollmorgen Industrial Drives RADFORD, VIRGINIA	OUTLINE & DIMENSION BDS4A-30 & 40 AMP					
ISS.	ECN NO.	DATE	APP'D.						SCALE	DWG. NO.	ISSUE			
2	84107 TDG	8-6-91	CJF					DWN. BY: EWR	DATE 07-12-91	CHK. BY: CJF	DATE 07-17-91	SCALE 1:4	DWG. NO. A-93156	ISSUE 4
3	84919 TDG	1-7-93	CJF											
4	87736 RRH	7-11-96												

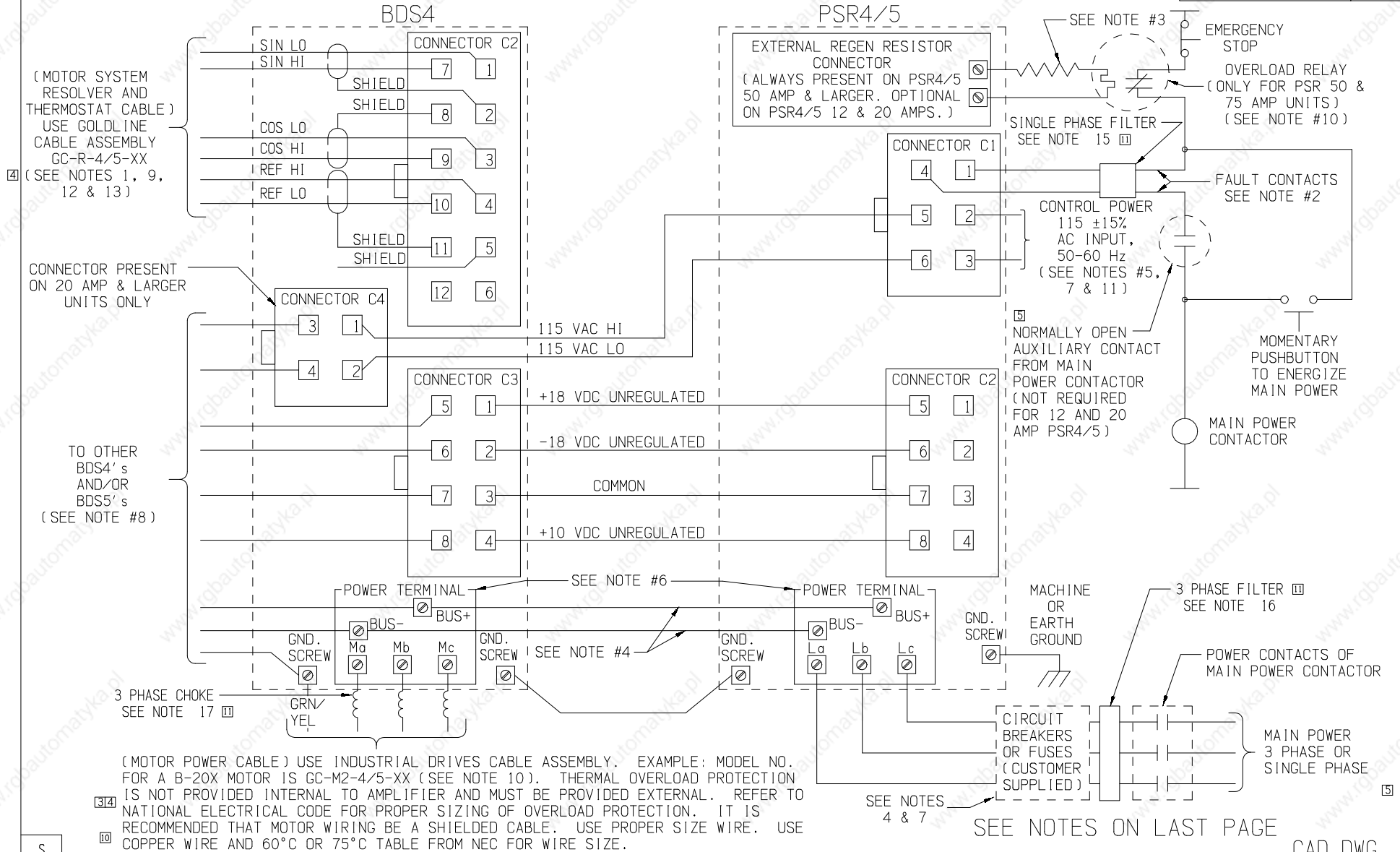

Q	K	C	B	COPY CODE	ISS.	ECN NO.	DATE	APP'D.	Kollmorgen Industrial Drives RADFORD, VIRGINIA				BDS4 WIRING DIAGRAM (PSR4/5 & MOTOR CONNECTIONS)				
ISS.	ECN NO.		DATE	APP'D.	2	84451 TDG	4-30-92	CJF					PLOT SCALE	DWG. NO.	SHEET 1 OF 7	ISSUE	
7	85118 TDG		3-22-93	CJF	3	84719 EWR	9-01-92	CJF	DWN. BY: VA	DATE: 1-09-91	CHK. BY: F.D.O.	DATE: 6-01-91	APP'D. BY: C.J.F.	DATE: 6-01-91	1:1	A-93231	12
8	85244 LLS		5-17-93	CJF	4	84837 TDG	11-3-92	CJF									
9	85823 TDG		5-10-94	CJF	5	84924 TDG	1-11-93	CJF									
10	85972 MAW		6-14-94	CJF	6	84968 EWR	2-4-93	CJF									

CAD DWG.

DIFFERENTIAL VELOCITY OR CURRENT COMMAND INPUT SCALED FOR ±10 VOLTS = FULL SCALE. SEE CIRCUIT TO THE RIGHT (ANALOG INPUT)

ADDITIONAL SINGLE ENDED INPUT TO THE VELOCITY LOOP.

* AN EXTERNAL RESISTOR TO COMMON MAY BE USED TO PROGRAM THE PEAK CURRENT LIMIT OF THE AMPLIFIER AS FOLLOWS:
 75% OF I PEAK WITH 8.6K ohm
 50% OF I PEAK WITH 3.5K ohm
 OR A POSITIVE VOLTAGE FROM 0 VDC TO 7.5 VDC MAY BE USED TO ADJUST THE PEAK CURRENT FROM 7.5% TO 100% OF ITS RATING.

I MONITOR IS A COMMON-REFERENCED SIGNAL SCALED FOR FULL CURRENT = 8 VOLTS. THIS SIGNAL HAS A 3K ohm RESISTOR IN LINE.

TACH MONITOR IS A COMMON-REFERENCED SIGNAL SCALED FOR 8 VOLTS AT MAXIMUM SYSTEM SPEED AS STATED ON THE TL SHEET. THIS SIGNAL HAS A 3K ohm RESISTOR IN LINE

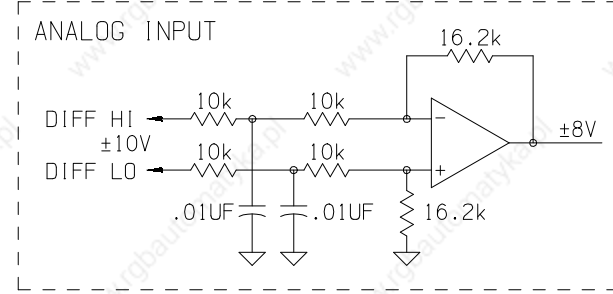
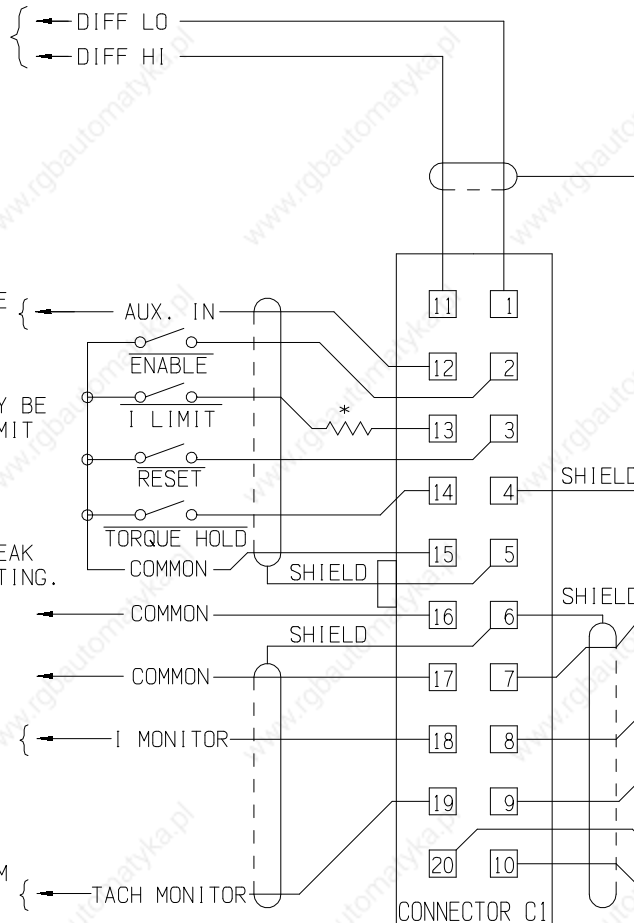

OUTPUT FAULT → OUTPUT FAULT IS A COMMON-REFERENCED, OPEN COLLECTOR SIGNAL. THE OUTPUT MAXIMUM RATING IS 30 VDC AND 25 MA.

FOLDBACK → FOLDBACK IS A COMMON-REFERENCED, OPEN COLLECTOR SIGNAL. THE OUTPUT MAXIMUM RATING IS 30 VDC AND 25 MA.

OVERTEMP → OVERTEMP IS A COMMON-REFERENCED, OPEN COLLECTOR SIGNAL. THE OUTPUT MAXIMUM RATING IS 30 VDC AND 25 MA.

DRIVE-UP RELAY → THE DRIVE-UP RELAY ACTS IN CONJUNCTION WITH THE ENABLE CIRCUIT IN ONE OF TWO POSSIBLE MODES: DRIVE-UP MODE OR O.K. TO ENABLE. THE RELAY CAN DRIVE UP TO 1 AMP RESISTIVE, AND THE CONTACTS ARE RATED FOR 115 VAC. THE RELAY MUST BE DERATED FOR INDUCTIVE LOADS.

CAD DWG.

ISS.		ECN NO.		DATE		APP'D.		Kollmorgen Industrial Drives RADFORD, VIRGINIA	BDS4 WIRING DIAGRAM (C1 CUSTOMER I/O)					
COPY CODE		ISS.		ECN NO.		DATE			PLOT SCALE					
ISS.		ECN NO.		DATE		APP'D.			DWG. NO.		SHEET 2 OF 7		ISSUE	
								VA		2-20-91		A-93231		12

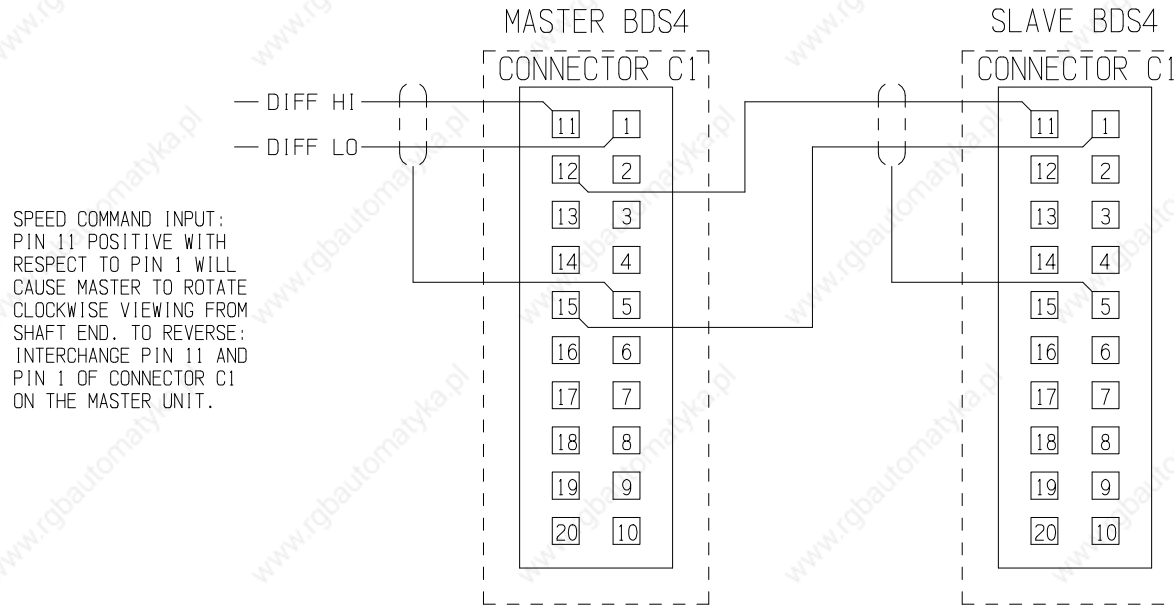

SPEED COMMAND INPUT:
PIN 11 POSITIVE WITH
RESPECT TO PIN 1 WILL
CAUSE MASTER TO ROTATE
CLOCKWISE VIEWING FROM
SHAFT END. TO REVERSE:
INTERCHANGE PIN 11 AND
PIN 1 OF CONNECTOR C1
ON THE MASTER UNIT.

CONNECTION SHOWN IS FOR MASTER
AND SLAVE TO ROTATE IN SAME DIRECTION.
TO ENABLE MASTER AND SLAVE TO ROTATE
IN OPPOSITE DIRECTION: INTERCHANGE
PIN 11 AND PIN 1 OF CONNECTOR C1 ON
THE SLAVE UNIT.

SYSTEM SETUP:

- ☑ 1) THE MASTER UNIT REQUIRES A MASTER (M) TYPE COMPENSATION CARD - DESIGNATED I.E BDS4-230J/XOXA2M
THE SLAVE REQUIRES A SLAVE (S) TYPE COMPENSATION CARD - DESIGNATED I.E. BDS4-230J/XOXA2S
- 2) FOR PROPER LOAD SHARING BETWEEN THE MASTER AND SLAVE UNITS, THE FOLLOWING ADJUSTMENT MUST BE MADE ON THE SLAVE UNIT (THE STABILITY AND COMMAND SCALE POTS NOW FUNCTION AS TORQUE GAIN ADJUSTMENTS):
 - A) ADJUST THE STABILITY POT FULLY COUNTER-CLOCKWISE
 - B) ADJUST THE COMMAND SCALE POT FULLY CLOCKWISE
 - C) ADJUST THE CURRENT LIMIT POT FULLY CLOCKWISE
 - D) UNDER LOAD CONDITIONS, THE LOAD SHARING MAY BE IMPROVED SLIGHTLY BY COMPARING EACH UNITS CURRENT MONITOR SIGNAL:
 - TO INCREASE LOAD ON THE SLAVE UNIT, ADJUST IT'S STABILITY POT CLOCKWISE
 - TO DECREASE LOAD ON THE SLAVE UNIT, ADJUST IT'S COMMAND SCALE POT COUNTER-CLOCKWISE
- 3) MASTER/SLAVE OPERATION IS INCOMPATIBLE WITH BRUSH TACH SYSTEMS.

CAD DWG.

				COPY CODE	ISS.	ECN NO.	DATE	APP'D.	Kollmorgen Industrial Drives RADFORD, VIRGINIA			BDS4 WIRING DIAGRAM (MASTER/SLAVE OPERATION)						
ISS.	ECN NO.	DATE	APP'D.												DWN. BY:	DATE	CHK. BY:	DATE
									VA	2-19-91					1:1	A-93231		12

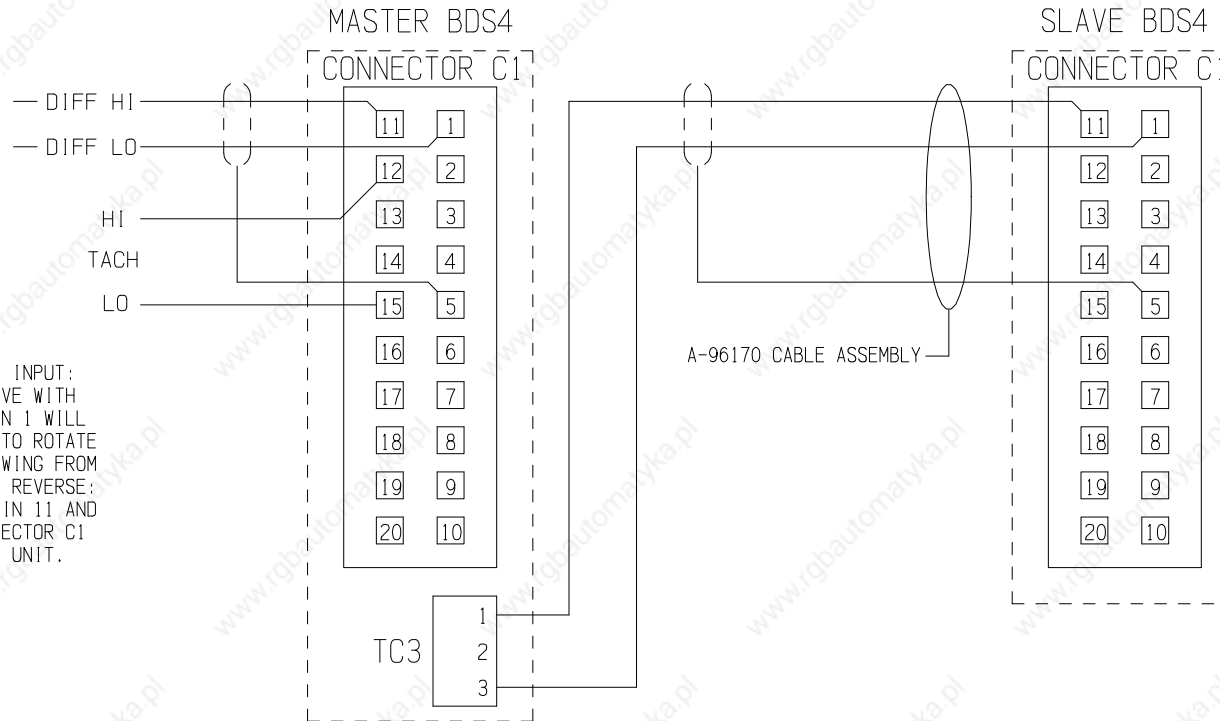

SYSTEM SETUP:

- 1) THE MASTER UNIT REQUIRES A MASTER (M) TYPE COMPENSATION CARD - DESIGNATED I.E BDS4-230J/XOXA2M
 THE SLAVE REQUIRES A SLAVE (S) TYPE COMPENSATION CARD - DESIGNATED I.E. BDS4-230J/XOXA2S
- 2) FOR PROPER LOAD SHARING BETWEEN THE MASTER AND SLAVE UNITS, THE FOLLOWING ADJUSTMENT MUST BE MADE ON THE SLAVE UNIT (THE STABILITY AND COMMAND SCALE POTS NOW FUNCTION AS TORQUE GAIN ADJUSTMENTS):
 - A) ADJUST THE STABILITY POT FULLY COUNTER-CLOCKWISE
 - B) ADJUST THE COMMAND SCALE POT FULLY CLOCKWISE
 - C) ADJUST THE CURRENT LIMIT POT FULLY CLOCKWISE
 - D) UNDER LOAD CONDITIONS, THE LOAD SHARING MAY BE IMPROVED SLIGHTLY BY COMPARING EACH UNITS CURRENT MONITOR SIGNAL:
 - TO INCREASE LOAD ON THE SLAVE UNIT, ADJUST IT'S STABILITY POT CLOCKWISE
 - TO DECREASE LOAD ON THE SLAVE UNIT, ADJUST IT'S COMMAND SCALE POT COUNTER-CLOCKWISE

CAD DWG.

COPY CODE				ISS.	ECN NO.	DATE	APP'D.	Kollmorgen Industrial Drives RADFORD, VIRGINIA	BDS4 WIRING DIAGRAM (MASTER/SLAVE W/TACH OPERATION)								
ISS.	ECN NO.	DATE	APP'D.						DWN. BY:	DATE	CHK. BY:	DATE	APP'D. BY:	DATE	PLOT SCALE	DWG. NO.	SHEET 4 OF 7
								VA	2-19-91					1:1	A-93231		12

NOTES:

- A. THE COMMONS OF MASTER BDS4 AND SLAVE BDS5 MUST BE CONNECTED. THIS IS ACCOMPLISHED THROUGH CONNECTOR C3 IN THE BDS4 AND CONNECTOR C4 IN THE BDS5 IF THEY SHARE ONE PSR4/5.
- B. IF THE BDS5 USES THE OPTIONAL ANALOG INPUT CARD (BDS5-OPT1), THE OPTIONAL ENCODER INPUTS IN CONNECTOR C1 ARE NOT ALLOWED.
- C. THE FILTER KIT USES A FERRISHIELD SLEEVE SNAP MODEL NO. SS33B2036 OR EQUIVALENT

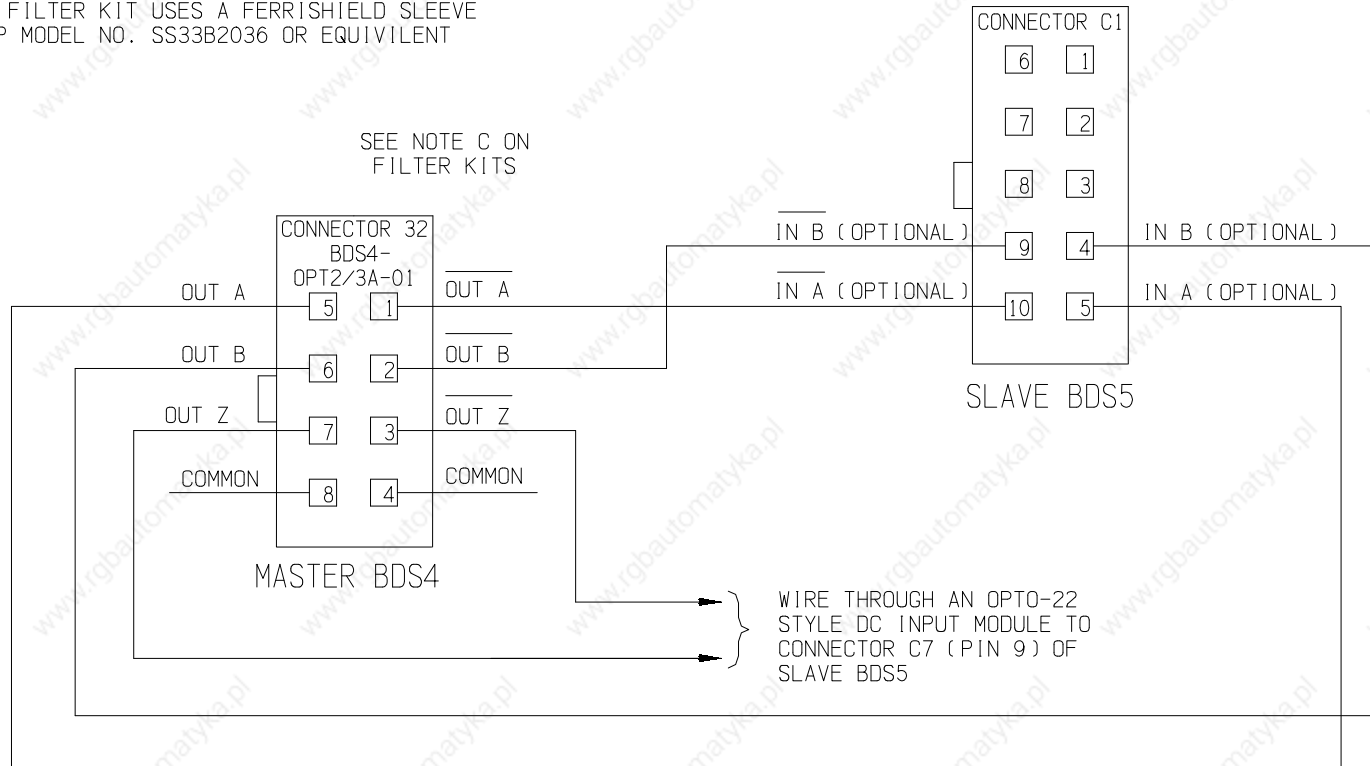

MASTER BDS4 AND SLAVE BDS5

CAD DWG.

ISS.		ECN NO.		COPY CODE		ISS.	ECN NO.	DATE	APP'D.	Kollmorgen Industrial Drives RADFORD, VIRGINIA	BDS4 WIRING DIAGRAM (OPTIONAL ENCODER EQUIVALENT)			
DATE		APP'D.		DATE		APP'D.		DATE			PLOT SCALE	DWG. NO.	SHEET 5 OF 7	ISSUE
										1:1	A-93231		12	

NOTES:

(ALL WIRES TO BE COPPER WITH MIN. TEMP RATING OF 60°C)

DWG. NO. SHEET 6 OF 7 ISSUE
A-93231 12

2
5

1. WARNING: THE MOTOR THERMOSTAT AUTOMATICALLY RESETS WHEN THE MOTOR COOLS. THE CUSTOMER IS RESPONSIBLE FOR LATCHING THIS SIGNAL TO INHIBIT OPERATION AFTER A MOTOR THERMOSTAT FAULT. CONNECT THERMOSTAT USING TWISTED PAIR WIRE.
2. CAUTION: THE PSR4/5 FAULT CONTACTS (RATED 115 VAC 1AMP) MUST BE WIRED IN SERIES WITH THE OVERLOAD RELAY AS SHOWN ON SHEET 1.
 ON 12 & 20 AMP PSR4/5: THIS CONTACT IS NORMALLY OPEN AND WILL CLOSE WITHIN 250 MSEC. AFTER APPLICATION OF CONTROL AND MAIN POWER. THIS CONTACT OPENS IN FAULT CONDITIONS.
 ON 50 & 75 AMP PSR4/5 THIS CONTACT CLOSSES ON APPLICATION OF CONTROL POWER AND WILL OPEN IN FAULT CONDITION.

3. WARNING: RESISTOR IS CONNECTED TO HIGH VOLTAGE; ENSURE SUFFICIENT ELECTRICAL CLEARANCE WHEN MOUNTING. RESISTOR MAY BECOME VERY HOT DURING OPERATION. DO NOT MOUNT NEAR MATERIALS THAT ARE FLAMMABLE OR DAMAGED BY HEAT. VENTILATION MAY BE REQUIRED.
 SEE WIRING DRAWING FOR SPECIFIC REGEN RESISTOR KIT. EACH KIT HAS DIFFERENT SERIES/PARALEL RESISTOR CONNECTIONS TO OBTAIN SPECIFIC RESISTANCE AND POWER RATING.

4. WIRE SIZES, BREAKERS AND FUSES FOR PSR4/5:
 PSR4/5-X12 HAS A MAXIMUM MAIN POWER INPUT CURRENT OF 12 AMPS RMS,
 PSR4/5-X20 HAS A MAXIMUM MAIN POWER INPUT CURRENT OF 20 AMPS RMS,
 PSR4/5-X50 HAS A MAXIMUM MAIN POWER INPUT CURRENT OF 50 AMPS RMS,
 PSR4/5-X75 HAS A MAXIMUM MAIN POWER INPUT CURRENT OF 75 AMPS RMS.

THE ACTUAL APPLICATION MAY REQUIRE LESS CURRENT. USE 600 VAC INSULATED WIRE AND REFER TO LOCAL ELECTRICAL CODES FOR PROPER WIRE SIZE FOR THE CURRENTS LISTED ABOVE. FUSES FOR MAIN POWER SHOULD BE A U.L. RATED TIME DELAY TYPE, SUCH AS, BUSS FRN-R SERIES.

THE POWER BUS BETWEEN A PSR4/5 AND BDS4 SHOULD USE THE FOLLOWING WIRE GAUGE WITH 600 VAC INSULATION:
 PSR4/5-X12, 14 AWG (OR LARGER) WIRE,
 PSR4/5-X20, 10 AWG WIRE,
 PSR4/5-X50, 8 AWG (OR LARGER) WIRE,
 PSR4/5-X75, 8 AWG (OR LARGER) WIRE.

6

5. ALL SIGNAL AND CONTROL WIRES TO BE 22-18 AWG WIRE. THE CRIMP TERMINALS FOR 22-18 AWG WIRE ARE SUPPLIED FOR USE WITH BDS4 CONNECTORS C1, C2, C3, C4, OPTION CONNECTOR AND PSR4/5 CONNECTORS C1 & C2. FOR 16 AWG WIRE USE MOLEX #39-00-0078 TERMINALS.
6. IN THE BDS4 3 AMP THRU 20 AMP AND THE PSR4/5 12 AMP AND 20 AMP, THE SCREWS IN THE POWER TERMINAL BLOCKS ARE CAPTIVE. DO NOT ATTEMPT TO REMOVE THEM TO USE RING TERMINALS. USE LOCKING SPRING SPADE TERMINALS SUCH AS HOLLINGSWORTH #XSS20954S OR #SS20947SF FOR 16 AWG WIRE AND #SS20836 OR #SS20832F FOR 12/10 AWG WIRE.

7. ALL AC LINES SHOULD BE TWISTED CABLES.
8. THE TOTAL NUMBER OF AXES ALLOWED, PER PSR4/5, DEPENDS ON THE PSR4/5 MODEL AND THE COMBINATION OF BDS4's AND/OR BDS5's:
 PSR4/5-X12: A MAXIMUM OF 4 BDS4s OR 3 BDS5s,
 PSR4/5-X20: A MAXIMUM OF 4 BDS4s OR 3 BDS5s,
 PSR4/5-X50: A MAXIMUM OF 6 BDS4s OR 6 BDS5s,
 PSR4/5-X75: A MAXIMUM OF 6 BDS4s OR 6 BDS5s.
 (IF THE BDS's ARE MIXED, THEN THE TOTAL NUMBER OF AXES THAT CAN BE USED WOULD BE THE MAXIMUM GIVEN FOR THE BDS5s.)
 AXIS EXPANSION ON THE PSR4/5 50 AND 75 AMP UNITS ARE ALSO LIMITED TO A MAXIMUM OF 4 BDS4s OR 3 BDS5s ON EITHER SIDE OF THE PSR4/5.
9. XX IN THE CABLE NUMBER STANDS FOR CABLE LENGTH IN METERS. CABLE LENGTH IS AVAILABLE FROM 3 TO 75 METERS IN INCREMENTS OF 3 METERS.
10. A THERMAL OVERLOAD RELAY IS SUPPLIED IN THE REGEN RESISTOR KIT FOR THE 50 AND 75 AMP PSR4/5's. THE THERMAL OVERLOAD RELAY, INCLUDED IN THE KIT, WAS SIZED FOR YOUR RESISTANCE AND POWER RATING. THE OUTPUT CONTACTS OF THE RELAY MUST BE WIRED TO DROP POWER TO THE MAIN POWER CONTACTOR IN A FAULT CONDITION, AS SHOWN ON SHEET 1.
11. DO NOT WIRE CONTROL POWER (PSR4/5 CONNECTOR C1) THROUGH THE MAIN POWER CONTACTOR. THIS IS SO THAT CONTROL POWER WON'T BE REMOVED IF PSR4/5 FAULT CONTACTS OPEN (THIS WOULD TURN OFF ANY FAULT LED).
12. ALL SHIELDED CABLES MUST HAVE SHIELD CONTINUITY FOR THE FULL LENGTH OF THE CABLE.
13. RESOLVER CABLE MUST BE INDIVIDUALLY SHIELDED PAIRS.
14. RECOMMENDED TORQUES FOR CONNECTION TO TERMINAL BLOCKS AND GROUND.
 - A. BDS4/5-3 TO 20 AMP AND PSR4/5-12 AND 20 AMP
 MAX TORQUE PER UL IS 12 IN/LB, EXTERNAL REGEN, MAIN POWER AND BUS CONNECTION.
 MAX TORQUE 12 IN/LB GROUND SCREW
 - B. BDS4/5-30 TO 55 AMP
 MAX TORQUE 20 IN/LB MOTOR, BUS CONNECTION AND GROUND STUD
 - C. PSR4/5-50 TO 75 AMP
 MAX TORQUE 20 IN/LB MAIN POWER, BUS CONNECTION AND GROUND STUD
 MAX TORQUE 12 IN/LB EXTERNAL REGEN CONNECTION

4

4

FOR GROUNDING TO MACHINE OR EARTH GROUND, A SCREW LUG SHOULD BE ATTACHED TO GROUND SCREW OR STUD. RECOMMENDED TORQUE OF 12 IN/LB FOR GROUND SCREWS AND 20 IN/LB FOR GROUND STUDS. MAY ALSO REFER TO NATIONAL ELECTRICAL CODE (NEC) OR UL STANDARD 486B FOR RECOMMENDED TORQUES

THERMAL OVERLOAD PROTECTION DOES NOT PROVIDE INTERNAL TO AMPLIFIER AND MUST BE PROVIDED EXTERNAL. REFER TO NATIONAL ELECTRICAL CODE FOR PROPER SIZING OF OVERLOAD PROTECTION.

CAD DWG.

				COPY CODE	ISS.	ECN NO.	DATE	APP'D.	Kollmorgen Industrial Drives RADFORD, VIRGINIA	BDS4 WIRING DIAGRAM (NOTES PG. 1)								
ISS.	ECN NO.	DATE	APP'D.							DWN. BY:	DATE	CHK. BY:	DATE	APP'D. BY:	DATE	SCALE	DWG. NO.	SHEET 6 OF 7
									VA	2-13-91					1:1	A-93231		12

1/4-20 x 1/2 PAN HD. SCREW, QTY(2)
 1/4 LOCKWASHER, QTY(2)
 1/4 FLATWASHER, .75" O.D., QTY(2)
 STANDOFF, SPRUCE PINE # 2165-1B, QTY(2)

1000 W CONTINUOUS
 4.4 OHM RESISTOR
 QTY(1) 1.750 DIA.

SET TRIP CURRENT
 TO: 15 AMPS

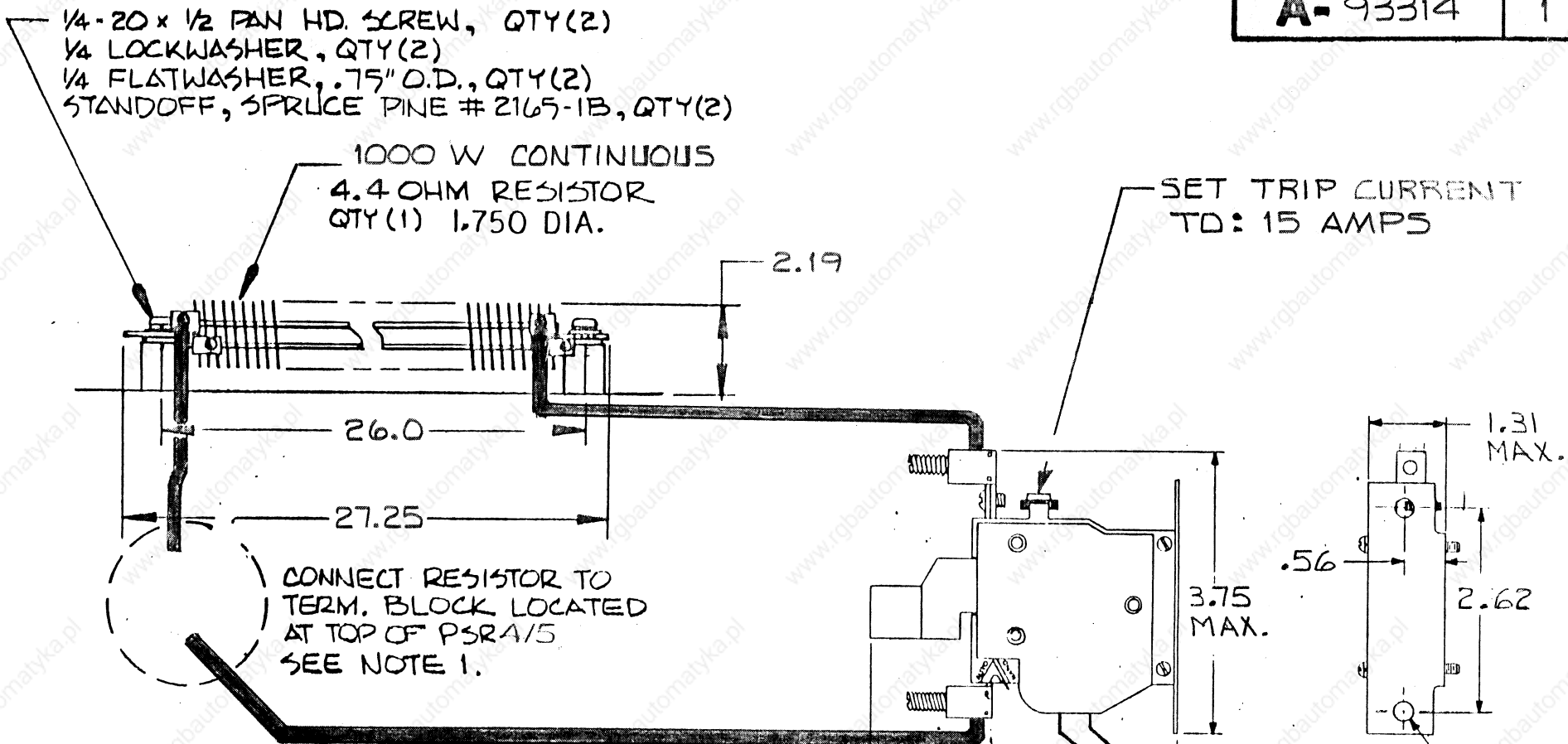

CONNECT RESISTOR TO
 TERM. BLOCK LOCATED
 AT TOP OF PSR4/5.
 SEE NOTE 1.

SEE
 NOTE
 # 3

SKB COPY CODE

CAUTION-1) DO NOT INSTALL RESISTOR NEAR
 FLAMMABLE MATERIAL.

NOTES: 2) SHOCK HAZARD & RESISTOR CONNECTED TO HIGH VOLTAGE.

1. RECOMMENDED WIRE: # 8AWG, 125°C
2. BOTTOM STANDOFFS ARE THREADED 1/4-20 x 3/8" DP FOR MOUNTING RESISTORS TO PANELS, ETC.
3. OUTPUT CONTACTS: WIRED TO DROP MAIN LINES WHEN CONTACTS OPEN ON OVERLOAD.

Kollmorgen Industrial Drives
 RADFORD, VIRGINIA

WIRING & MOUNTING DIAG.
 ER-21

SCALE: — DWG. NO. **A-93314** ISSUE 1

UNLESS OTHERWISE SPECIFIED XX DEC. PLACES ±.018 XXX DEC. PLACES ±.008 ANG. DIM. ± 1"	ISS.	ECN NO.	DATE	APP'D	ISS.	ECN NO.	DATE	APP'D	DW'N BY	DATE
										TDG
									CHK BY	
DO NOT SCALE DWG. USE DIMENSIONS ONLY ALL DIMENSIONS ARE INCHES UNLESS OTHERWISE SPECIFIED									APP'D BY	5-23-91

- 1/4-20 x 1/2 PAN HD. SCREW QTY (2)
- 1/4 LOCKWASHER QTY (2)
- 1/4 FLATWASHER QTY (2)
- 1/4-20 x 1/2 THREADED STUD QTY (4)
- STAND-OFF, SPRUCE PINE #2165-1B QTY (6)
- 4.5 OHM RESISTOR, QTY (2) ²

RATED POWER: 1000 W
TOTAL RESISTANCE: 2.25 Ω

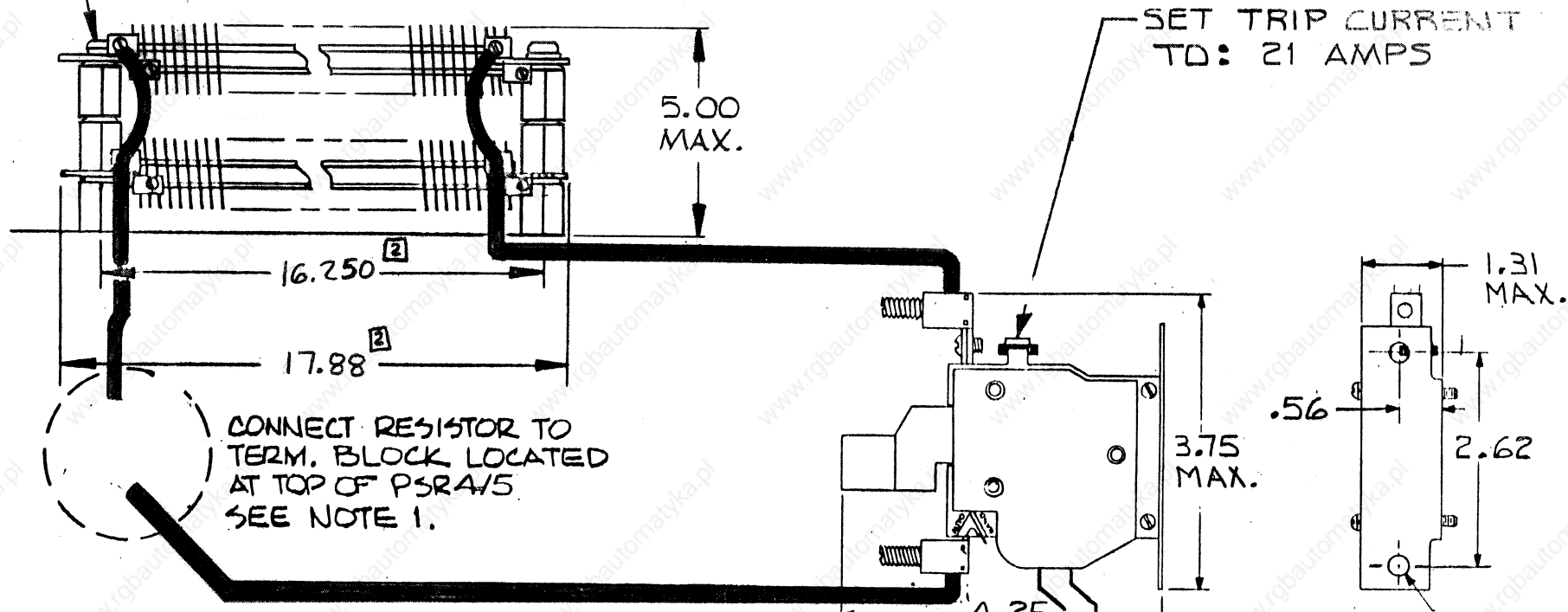

CONNECT RESISTOR TO TERM. BLOCK LOCATED AT TOP OF PSRA/5 SEE NOTE 1.

SET TRIP CURRENT TO: 21 AMPS

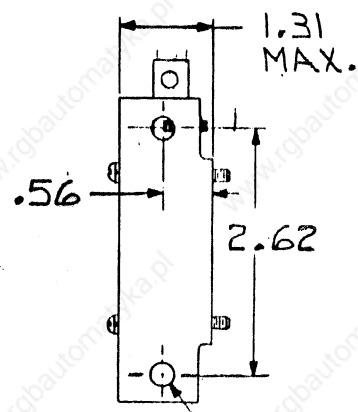

SEE NOTE # 3

SKB COPY CODE

CAUTION - DO NOT INSTALL RESISTOR NEAR FLAMMABLE MATERIAL.

- NOTES:
1. RECOMMENDED WIRE: # 8AWG, 125°C
 2. BOTTOM STANDOFFS ARE THREADED 1/4-20 x 3/8" DP FOR MOUNTING RESISTORS TO PANELS, ETC.
 3. OUTPUT CONTACTS: WIRED TO DROP MAIN LINES WHEN CONTACTS OPEN ON OVERLOAD.

Kollmorgen Industrial Drives
RADFORD, VIRGINIA

WIRING & MOUNTING DIAG.
ER-22

UNLESS OTHERWISE SPECIFIED XX DEC. PLACES ±.015 XXX DEC. PLACES ±.008 ANG. DIM. ± 1'	ISS.	ECN NO.	DATE	APP'D	ISS.	ECN NO.	DATE	APP'D	DW'N BY	DATE
						2	88054 JDG	6/1/96	[Signature]	TDG

SCALE:	DWG. NO.	ISSUE
—	A-93315	2

DO NOT SCALE DWG. USE DIMENSIONS ONLY
ALL DIMENSIONS ARE INCHES
UNLESS OTHERWISE SPECIFIED

- 1/4-20 x 1/2 PAN HD. SCREW QTY (2)
- 1/4 LOCKWASHER QTY (2)
- 1/4 FLATWASHER QTY (2)
- 1/4-20 x 1/2 THREADED STUD QTY (4)
- STAND-OFF, SPRUCE PINE #2165-1B QTY (6)
- 4.4 OHM RESISTOR, 1000 W QTY (2)

RATED POWER: 2000 W
 TOTAL RESISTANCE: 2.2 Ω

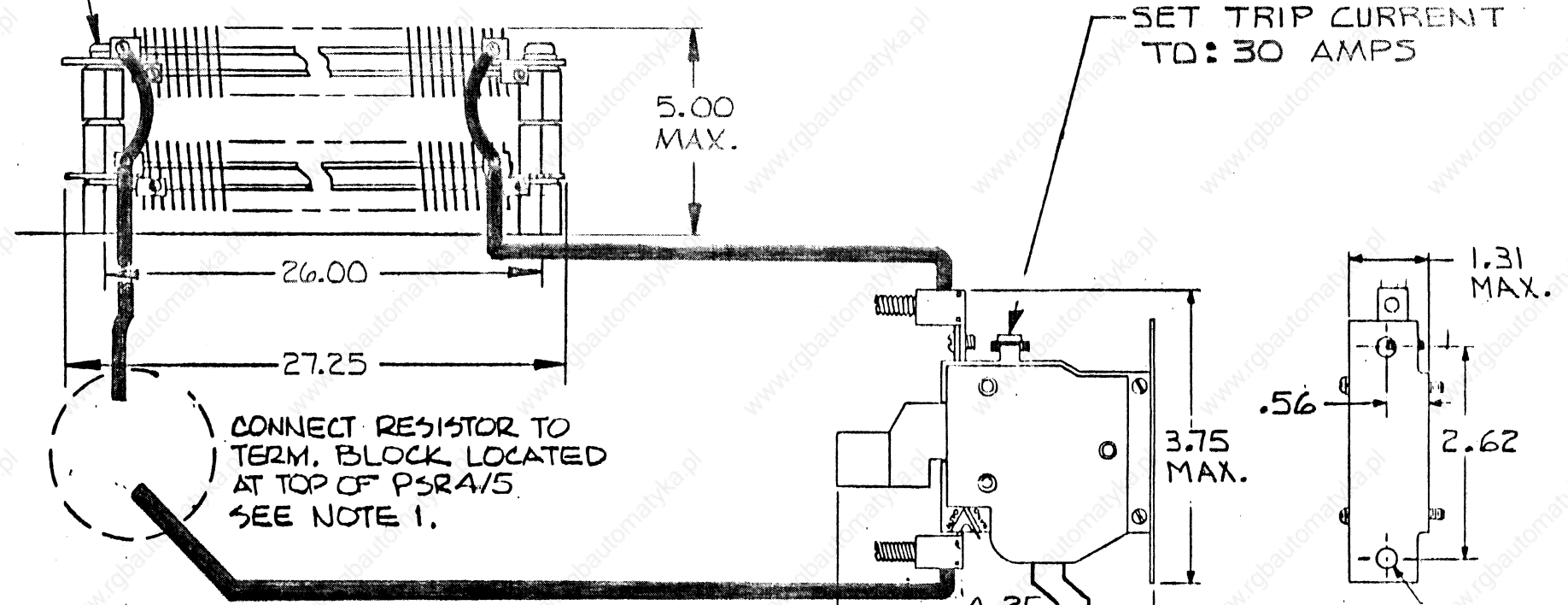

CAUTION-1) DO NOT INSTALL RESISTOR NEAR FLAMMABLE MATERIAL.

NOTES: 2) SHOCK HAZARD & RESISTOR CONNECTED TO HIGH VOLTAGE.

1. RECOMMENDED WIRE: # 8 AWG, 125°C
2. BOTTOM STANDOFFS ARE THREADED 1/4-20 x 3/8" DP FOR MOUNTING RESISTORS TO PANELS, ETC.
3. OUTPUT CONTACTS: WIRED TO DROP MAIN LINES WHEN CONTACTS OPEN ON OVERLOAD.

SNK B COPY CODE

Kollmorgen Industrial Drives
 RADFORD, VIRGINIA

WIRING & MOUNTING DIAG.
 ER-23

UNLESS OTHERWISE SPECIFIED XX DEC. PLACES ±.010 XXX DEC. PLACES ±.000 ANG. DIM. ± 1'	ISS.	ECN NO.	DATE	APP'D	ISS.	ECN NO.	DATE	APP'D	DW'N BY	DATE
										TDG
									CHK BY	
									APP'D BY	5-23-91

SCALE:	DWG. NO.	ISSUE
—	A-93316	1

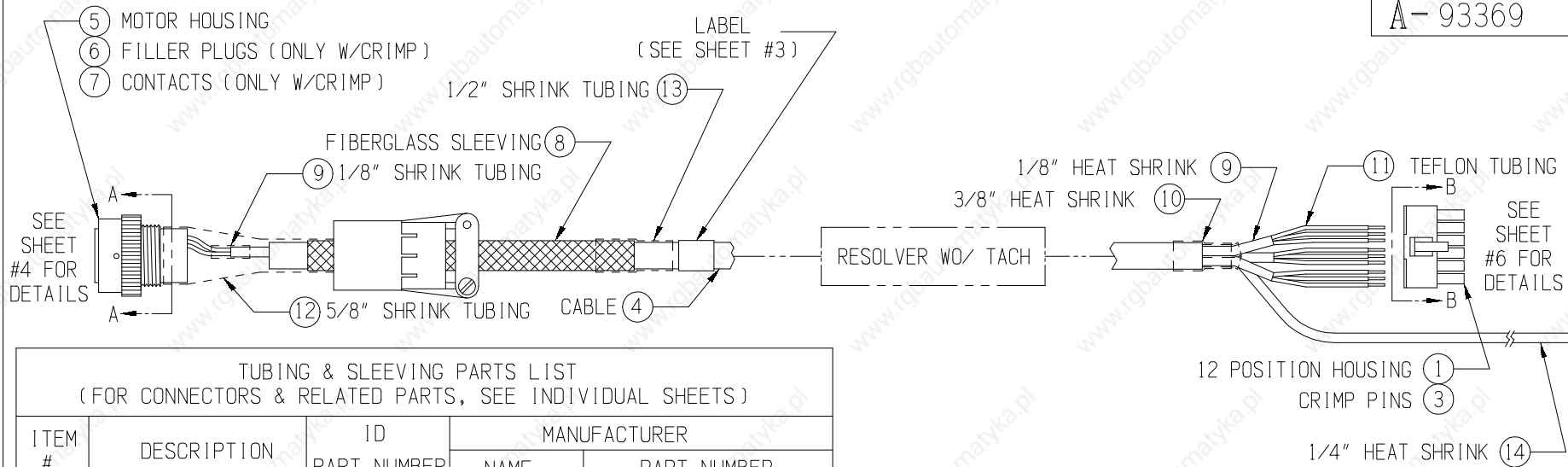

TUBING & SLEEVING PARTS LIST
 (FOR CONNECTORS & RELATED PARTS, SEE INDIVIDUAL SHEETS)

ITEM #	DESCRIPTION	ID PART NUMBER	MANUFACTURER	
			NAME	PART NUMBER
#8	FBRGLASS SLEEVING	A-84824-025	MARKEL	H455BA1000
#9	1/8" SHRINK TUB.	G-15266	RAYCHEM	RNF-100-1-1/8"
#10	3/8" SHRINK TUB.	H-15063	RAYCHEM	RNF-100-1-3/8"
#11	TEFLON TUB.	H-15079	RAYCHEM	TFL16
#12	5/8" SHRINK TUB.	H-15577	RAYCHEM	RNF-100-1-5/8"
#13	1/2" SHRINK TUB.	H-15699	RAYCHEM	RNF-100-1-1/2"
#14	1/4" SHRINK TUB.	G-15267	RAYCHEM	RNF-100-1-1/4"

DASH NO.	CABLE LENGTH		DASH NO.	CABLE LENGTH		DASH NO.	CABLE LENGTH	
	METERS	FEET		METERS	FEET		METERS	FEET
-003	3	11	-027	27	91	-051	51	171
-006	6	21	-030	30	101	-054	54	181
-009	9	31	-033	33	111	-057	57	191
-012	12	41	-036	36	121	-060	60	201
-015	15	51	-039	39	131	-063	63	211
-018	18	61	-042	42	141			
-021	21	71	-045	45	151			
-024	24	81	-048	48	161			

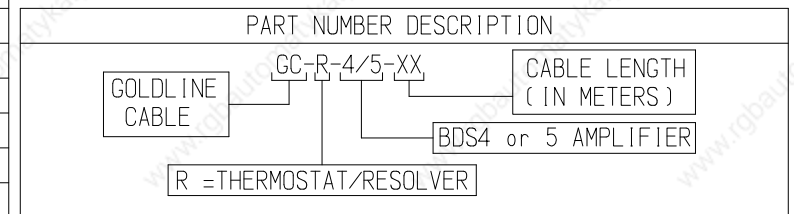

S		K		COPY CODE		ISS.	ECN NO.		DATE	APP'D.	Kollmorgen Industrial Drives RADFORD, VIRGINIA				GOLDLINE AMPLIFIER ASSEMBLY GUIDE FOR RESOLVER CABLES				
ISS.	ECN NO.	DATE	APP'D.	2	84691	EWR	8-21-92	FDO											
6	87203	JDG	9-13-95	SCM	3	84797	EWR	10-5-92	FDO										
7	88125	ESS	3-13-97	MB	4	85531	LLS	12-16-93	CJF	DWN. BY:	DATE	CHK. BY:	DATE	APP'D. BY:	DATE	SCALE	DWG. NO.	SHEET 1 OF 14	ISSUE
8	89055	JMM	05-15-97		5	86008	AWL	08-02-94	FDO	EWR	05-18-92	FDO	05-18-92	OWENS	05-18-92	1:1	A-93369		8

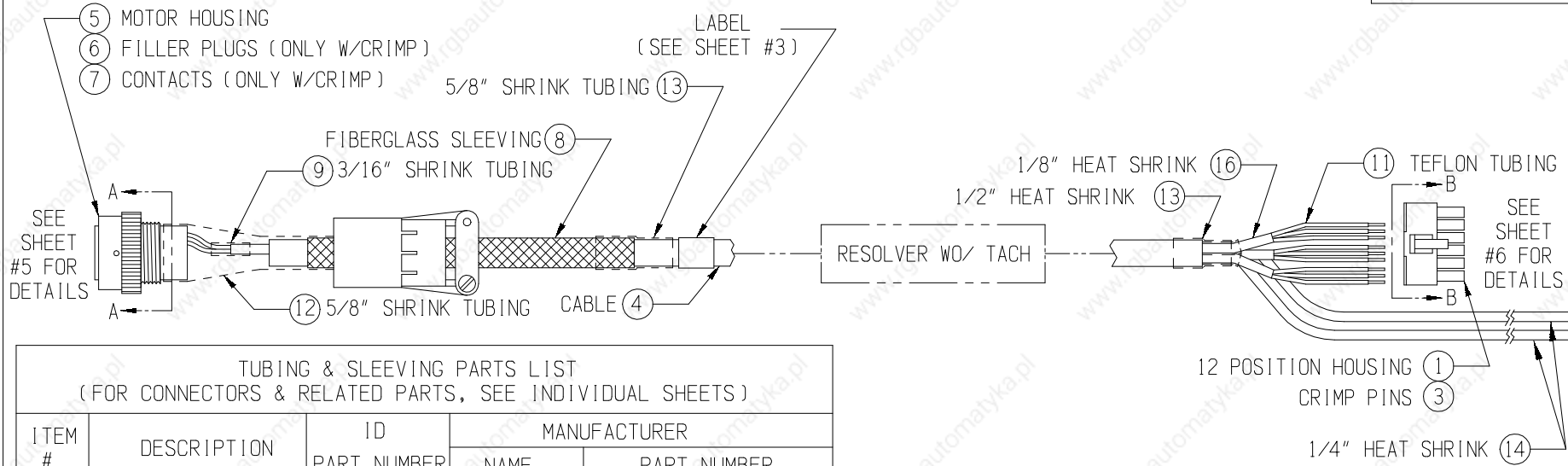

TUBING & SLEEVING PARTS LIST
 (FOR CONNECTORS & RELATED PARTS, SEE INDIVIDUAL SHEETS)

ITEM #	DESCRIPTION	ID PART NUMBER	MANUFACTURER	
			NAME	PART NUMBER
#8	FBRGLASS SLEEVING	A-84824-025	MARKEL	H455BA1000
#9	1/8" SHRINK TUB.	G-15266	RAYCHEM	RNF-100-1-1/8"
#11	TEFLON TUB.	H-15079	RAYCHEM	TFL16
#12	5/8" SHRINK TUB.	H-15577	RAYCHEM	RNF-100-1-5/8"
#13	1/2" SHRINK TUB.	H-15699	RAYCHEM	RNF-100-1-1/2"
#14	1/4" SHRINK TUB.	G-15267	RAYCHEM	RNF-100-1-1/4"

DASH NO.	CABLE LENGTH		DASH NO.	CABLE LENGTH		DASH NO.	CABLE LENGTH	
	METERS	FEET		METERS	FEET		METERS	FEET
-003	3	11	-027	27	91	-051	51	171
-006	6	21	-030	30	101	-054	54	181
-009	9	31	-033	33	111	-057	57	191
-012	12	41	-036	36	121	-060	60	201
-015	15	51	-039	39	131	-063	63	211
-018	18	61	-042	42	141			
-021	21	71	-045	45	151			
-024	24	81	-048	48	161			

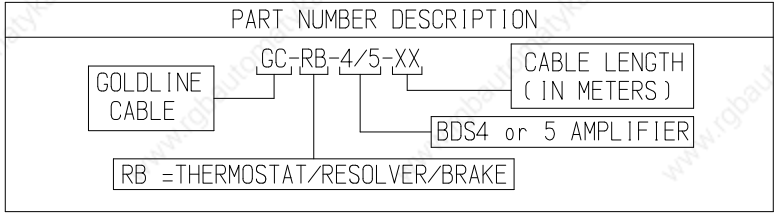

ISS.	S	K	COPY CODE	ISS.	ECN NO.	DATE	APP'D.	Kollmorgen Industrial Drives RADFORD, VIRGINIA				GOLDLINE AMPLIFIER ASSEMBLY GUIDE FOR RESOLVER CABLES					
								DWN. BY:	DATE	CHK. BY:	DATE	APP'D. BY:	DATE	SCALE	DWG. NO.	SHEET 2 OF 14	ISSUE
								EWR	05-18-92					1:1	A-93369		8

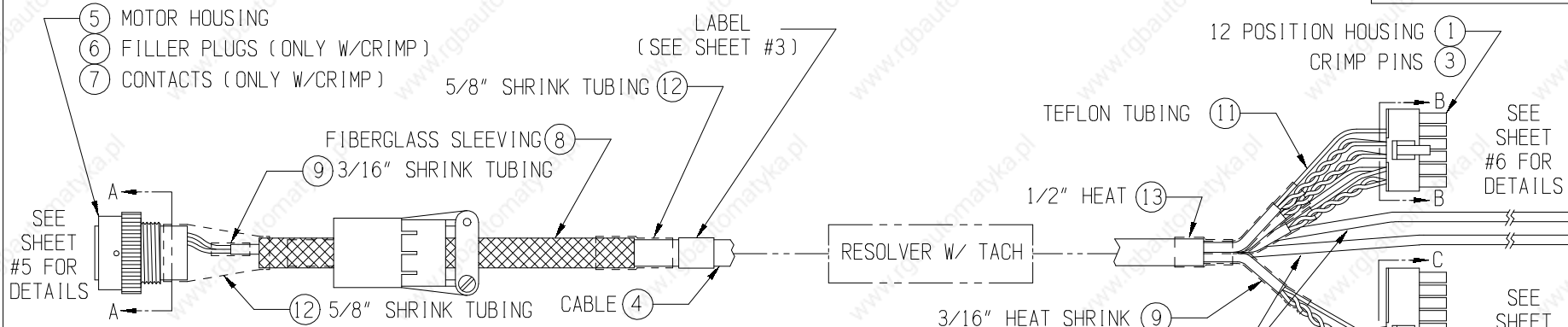

TUBING & SLEEVING PARTS LIST
 (FOR CONNECTORS & RELATED PARTS, SEE INDIVIDUAL SHEETS)

ITEM #	DESCRIPTION	ID PART NUMBER	MANUFACTURER	
			NAME	PART NUMBER
#8	FBRGLASS SLEEVING	A-84824-026	MARKEL	H457BA1000
#9	1/8" SHRINK TUB.	G-15265	RAYCHEM	RNF-100-1-1/8"
#11	TEFLON TUB.	H-15079	RAYCHEM	TFL16
#12	5/8" SHRINK TUB.	H-15577	RAYCHEM	RNF-100-1-5/8"
#13	1/2" SHRINK TUB.	H-15699	RAYCHEM	RNF-100-1-1/2"
#14	1/4" SHRINK TUB.	G-15267	RAYCHEM	RNF-100-1-1/4"

DASH NO.	CABLE LENGTH		DASH NO.	CABLE LENGTH		DASH NO.	CABLE LENGTH	
	METERS	FEET		METERS	FEET		METERS	FEET
-003	3	11	-027	27	91	-051	51	171
-006	6	21	-030	30	101	-054	54	181
-009	9	31	-033	33	111	-057	57	191
-012	12	41	-036	36	121	-060	60	201
-015	15	51	-039	39	131			211
-018	18	61	-042	42	141			
-021	21	71	-045	45	151			
-024	24	81	-048	48	161			

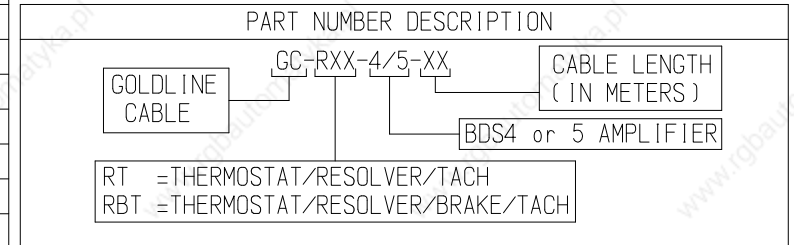

ISS.	S	K	COPY CODE	ISS.	ECN NO.	DATE	APP'D.

Kollmorgen Industrial Drives
 RADFORD, VIRGINIA

GOLDLINE AMPLIFIER ASSEMBLY
 GUIDE FOR RESOLVER CABLES

DWN. BY:	DATE	CHK. BY:	DATE	APP'D. BY:	DATE	SCALE	DWG. NO.	SHEET 3 OF 14	ISSUE
EWR	05-18-92					1:1	A-93369		8

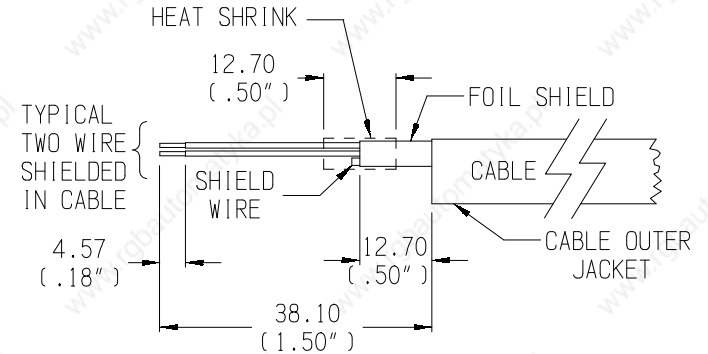
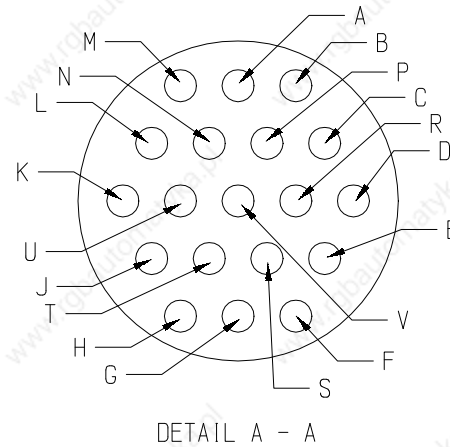
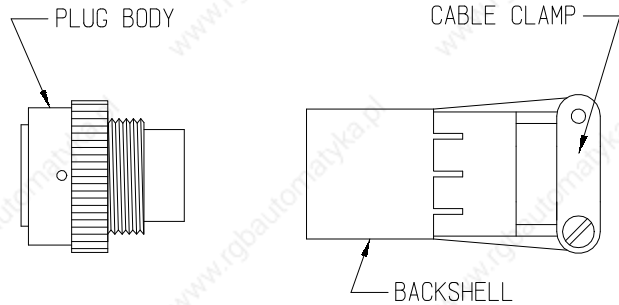

CONNECTOR ASSEMBLY PROCEDURE

STEP 1 BEFORE ANY OUTER JACKET HAS BEEN REMOVED FROM THE CABLE, SLIDE THE FOLLOWING ITEMS ONTO THE CABLE: 12.7MM (1/2") SHRINK TUBING, FIBERGLASS SLEEVING, BACKSHELL AND 15.88 (5/8) SHRINK TUBING.

STEP 2 STRIP THE OUTER CABLE JACKET BACK 38.1MM (1.5"). THIS WILL EXPOSE THE INDIVIDUAL FOIL SHIELDED WIRES. (THE DIAGRAM ONLY SHOWS ONE SHIELDED PAIR FOR CLARITY)

- STEP 3 A REMOVE THE FOIL SHIELD FROM THE WIRE.
 B CUT THE SHIELD WIRE FLUSH WITH THE FOIL SHIELD.
 C PLACE HEATSHRINK OVER THE END OF THE FOIL SHIELD AND SHIELD WIRE TO KEEP THE SHIELDS FROM TOUCHING.
 D USE STRIPPING PLIERS TO STRIP INSULATION 4.57MM (.18") FROM INDIVIDUAL WIRES.

- STEP 4 A FOR CRIMP CONNECTORS:
 B INSERT FILLER PLUGS IN: M, L, K, J, H, G & V UNTIL THEY ARE FLUSH WITH THE PLUG.
 C INSERT WIRES INTO THE CRIMP CONTACTS AND CRIMP. INSERT THE CRIMP CONTACTS INTO THE PLUG BODY, WITH USE OF GUIDE PINS, ACCORDING TO THE CONNECTION CHART.

STEP 4 A FOR SOLDER CONTACTS:
 INSERT THE WIRES INTO THE SOLDER CUPS AND SOLDER.

STEP 5 A POSITION THE 5/8" HEAT SHRINK TUBING AND FIBERGLASS SLEEVING AS PICTURED ON SHEET #1. APPLY HEAT TO SHRINK TUBING.

- B SLIDE THE BACKSHELL ALONG THE CABLE TO PLUG BODY.
 C HOLD PLUG BODY SECURE AND SCREW BACKSHELL ONTO PLUG BODY.
 D TIGHTEN CABLE CLAMP.
 E POSITION THE 1/2" SHRINK TUBING AS PICTURED ON SHEET #1. APPLY HEAT TO SHRINK TUBING.

STEP 6 PLACE LABEL IN APPROXIMATE LOCATION AS SHOWN ON SHEET #1. REFER TO NOTE BELOW CONNECTION CHART, SAME AS USED IN STEP 4 A, FOR CORRECT LABEL MARKING.

NOTE: 1. FOR CABLE ASSEMBLY GC-R-4/5-XXSEE SHEET #7 OR 8

ISS.	ECN NO.	DATE	APP'D.	ISS.	ECN NO.	DATE	APP'D.	Kollmorgen Industrial Drives RADFORD, VIRGINIA			GOLDLINE AMPLIFIER ASSEMBLY GUIDE FOR RESOLVER CABLES					
											SCALE	DWG. NO.	SHEET 4 OF 14	ISSUE		
								DOWN BY:	DATE	CHK. BY:	DATE	APP'D. BY:	DATE	1:1	A-93369	8
								EWR	08-12-92							

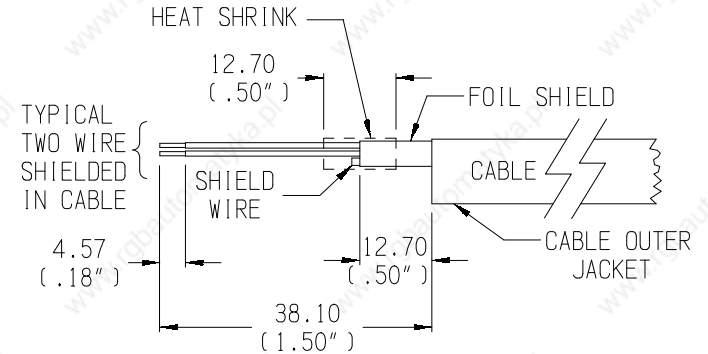
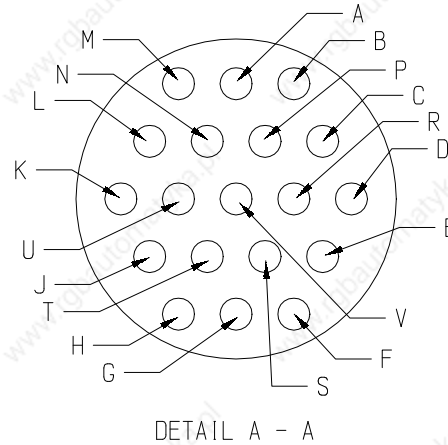
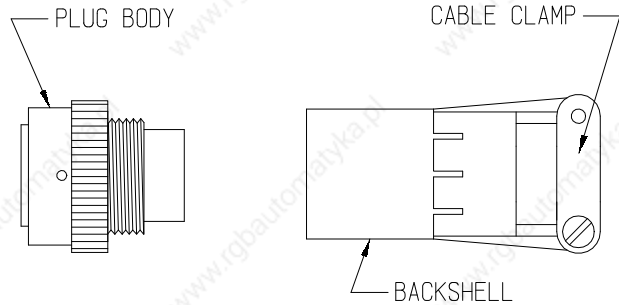

CONNECTOR ASSEMBLY PROCEDURE

- STEP 1 BEFORE ANY OUTER JACKET HAS BEEN REMOVED FROM THE CABLE, SLIDE THE FOLLOWING ITEMS ONTO THE CABLE: 15.8 (5/8") X 25.4 (1.00") LONG SHRINK TUBING, FIBERGLASS SLEEVING, BACKSHELL AND 15.88 (5/8) X 31.7 (1.25") SHRINK TUBING.
- STEP 2 STRIP THE OUTER CABLE JACKET BACK 38.1MM (1.5"). THIS WILL EXPOSE THE INDIVIDUAL FOIL SHIELDED WIRES. (THE DIAGRAM ONLY SHOWS ONE SHIELDED PAIR FOR CLARITY)
- STEP 3 A REMOVE THE FOIL SHIELD FROM THE WIRE.
 B CUT THE SHIELD WIRE FLUSH WITH THE FOIL SHIELD.
 C PLACE HEATSHRINK OVER THE END OF THE FOIL SHIELD AND SHIELD WIRE TO KEEP THE SHIELDS FROM TOUCHING.
 D USE STRIPPING PLIERS TO STRIP INSULATION 4.57MM (.18") FROM INDIVIDUAL WIRES.
- STEP 4 A FOR CRIMP CONNECTORS:
 B INSERT FILLER PLUGS IN:M,L,K,J,H,G & V UNTIL THEY ARE FLUSH WITH THE PLUG.
 C INSERT WIRES INTO THE CRIMP CONTACTS AND CRIMP. INSERT THE CRIMP CONTACTS INTO THE PLUG BODY, WITH USE OF GUIDE PINS, ACCORDING TO THE CONNECTION CHART.

- STEP 4 A FOR SOLDER CONTACTS:
 INSERT THE WIRES INTO THE SOLDER CUPS AND SOLDER.
- STEP 5 A POSITION THE 5/8" X 1.25" HEAT SHRINK TUBING AND FIBERGLASS SLEEVING AS PICTURED ON SHEET #1. APPLY HEAT TO SHRINK TUBING.
 B SLIDE THE BACKSHELL ALONG THE CABLE TO PLUG BODY.
 C HOLD PLUG BODY SECURE AND SCREW BACKSHELL ONTO PLUG BODY.
 D TIGHTEN CABLE CLAMP.
 E POSITION THE 5/8" X 1.00" SHRINK TUBING AS PICTURED ON SHEET #1. APPLY HEAT TO SHRINK TUBING.
- STEP 6 PLACE LABEL IN APPROXIMATE LOCATION AS SHOWN ON SHEET #1. REFER TO NOTE BELOW CONNECTION CHART, SAME AS USED IN STEP 4 A, FOR CORRECT LABEL MARKING.

NOTE: 1. FOR CABLE ASSEMBLY GC-RB-4/5-XXSEE SHEET #9 OR 10
 FOR CABLE ASSEMBLY GC-RT-4/5-XXSEE SHEET #11 OR 12
 FOR CABLE ASSEMBLY GC-RBT-4/5-XX ...SEE SHEET #13 OR 14

		S	K	COPY CODE	ISS.	ECN NO.	DATE	APP'D.	Kollmorgen Industrial Drives RADFORD, VIRGINIA		GOLDLINE AMPLIFIER ASSEMBLY GUIDE FOR RESOLVER CABLES							
ISS.	ECN NO.	DATE	APP'D.															
									DWN. BY:	DATE	CHK. BY:	DATE	APP'D. BY:	DATE	SCALE	DWG. NO.	SHEET 5 OF 14	ISSUE
									EWR	08-12-92					1:1	A-93369		8

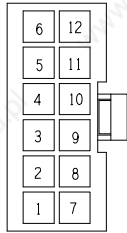

DETAIL B - B

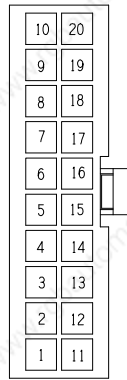

DETAIL C - C

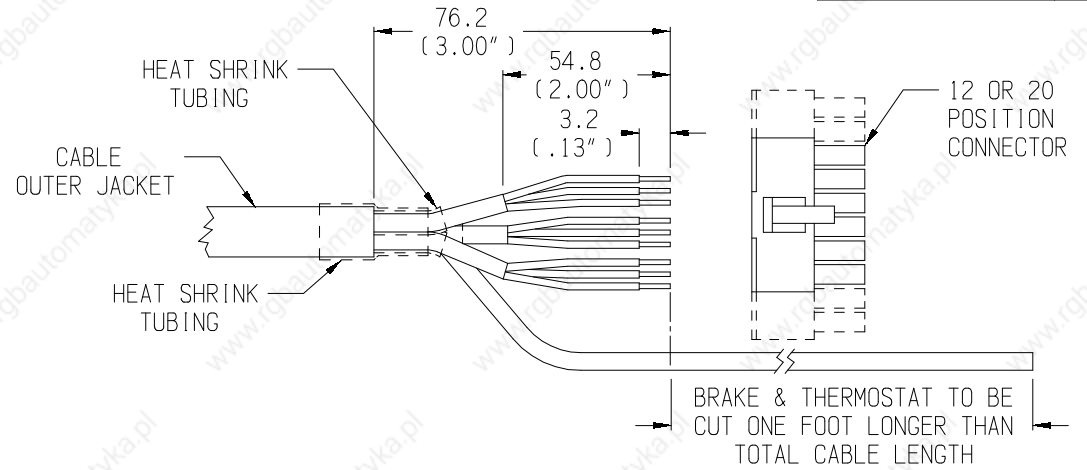

CONNECTOR ASSEMBLY PROCEDURE

- STEP 1 BEFORE ANY OUTER JACKET HAS BEEN REMOVED FROM THE CABLE, SLIDE A SECTION OF HEAT SHRINK TUBING ONTO THE CABLE.
- STEP 2 STRIP THE CABLE OUTER JACKET BACK, 381MM (15.00"). THIS WILL EXPOSE THE INDIVIDUAL FOIL SHIELDS.
- STEP 3 ACCORDING TO THE CONNECTION CHART, SELECT ONE OF THE WIRE PAIRS AND COMPLETE THE FOLLOWING OPERATIONS. SEE NOTE #1.
 - A REMOVE THE FOIL SHIELD FROM THE WIRE.
 - B COVER SHIELD WIRE WITH TUBING.
 - C COVER THE THREE LEADS WITH HEAT SHRINK.
 - D USE STRIPPING PLIERS TO STRIP INSULATION FROM INDIVIDUAL WIRES, 3.2MM (.13").
 - E CRIMP PINS TO EACH OF THE THREE WIRES.
 - F INSERT WIRES INTO 12 OR 20 POSITION CONNECTOR.

- STEP 4 PERFORM STEP 3 FOR EACH REMAINING PAIRS.
- STEP 5 SLIDE THE HEATSHRINK TUBING, FROM STEP #1, ONTO THE END OF THE CABLE AND SHRINK, AS SHOWN ABOVE.

NOTE :

- 1. FOR CABLE ASSEMBLY GC-R-4/5-XXSEE SHEET #7 OR 8
- FOR CABLE ASSEMBLY GC-RB-4/5-XXSEE SHEET #9 OR 10
- FOR CABLE ASSEMBLY GC-RT-4/5-XX ...SEE SHEET #11 OR 12
- FOR CABLE ASSEMBLY GC-RBT-4/5-XX ...SEE SHEET #13 OR 14

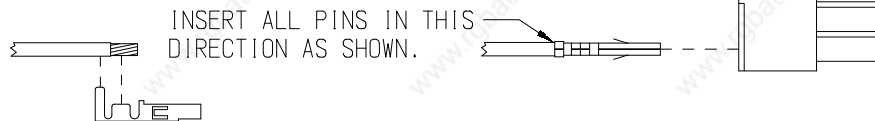

		S	K	COPY CODE	ISS.	ECN NO.	DATE	APP'D.	Kollmorgen Industrial Drives RADFORD, VIRGINIA		GOLDLINE AMPLIFIER ASSEMBLY GUIDE FOR RESOLVER CABLES								
ISS.	ECN NO.	DATE	APP'D.											DWN. BY:	DATE	CHK. BY:	DATE	APP'D. BY:	DATE
									EWR	08-12-92						1:1	A-93369		8

(W/CRIMPED MOTOR CONNECTOR)
 GOLDLINE RESOLVER CABLE WITH THERMOSTAT (GC-R-4/5-XX)

DWG. NO. SHEET 7 OF 14 | ISSUE
A-93369 | 8

PARTS LIST

CABLE				
ITEM #	DESCRIPTION	ID PART NUMBER	MANUFACTURER	
			NAME	PART NUMBER
#4	4 PAIR	A-81948	BELDEN	8725

MOTOR CONNECTOR AND ACCESSORIES				
ITEM #	DESCRIPTION	ID PART NUMBER	MANUFACTURER	
			NAME	PART NUMBER
#5	MOTOR HOUSING	A-84822	SOURIAU	851-06RX14-19S50-L
#7	CRIMP CONTACT	A-84823-002	SOURIAU	8500-1758
#6	FILLER PLUG	A-84823-001	SOURIAU	8500-4144A
	CRIMP TOOL	N/A	SOURIAU	MS3191-1

BDS4 C2 OR BDS5 C3 AND ACCESSORIES				
ITEM #	DESCRIPTION	ID PART NUMBER	MANUFACTURER	
			NAME	PART NUMBER
#1	12 POS. HOUSING	A-83908-012	MOLEX	39-01-2125
#3	CRIMP PIN	A-83909-002	MOLEX	39-00-0039
	CRIMP TOOL	N/A	MOLEX	HTR-60622

CONNECTION CHART

MOTOR CONNECTION ITEM #5	* CABLE ITEM #4	BDS4 C2 or BDS5 C3 ITEM #1	BDS4 C1 ITEM #2
TERMINAL A	RED	TERMINAL 7	N/C
TERMINAL B	BLACK	TERMINAL 1	
N/C	SHIELD	TERMINAL 8	
TERMINAL C	WHT/YEL	TERMINAL 3	
TERMINAL D	WHT/GRN	TERMINAL 9	
N/C	SHIELD	TERMINAL 2	
TERMINAL E	WHT/RED	TERMINAL 10	
TERMINAL F	WHT/BLK	TERMINAL 4	
N/C	SHIELD	TERMINAL 5	
TERMINAL N			
TERMINAL P		N/C	
TERMINAL R			
TERMINAL S		N/C	
TERMINAL T	GREEN	CUSTOMER	
TERMINAL U	WHITE	THERMOSTAT	
N/C	SHIELD	HOOK-UP	

SEE SHEET 5 AND 6 FOR CONNECTOR DETAILS.
 * THIS CABLE ASSEMBLY TO BE LABELED "GC-R-4/5-XX".

CABLE LENGTH

S		K		COPY CODE		ISS.	ECN NO.	DATE	APP'D.	Kollmorgen Industrial Drives RADFORD, VIRGINIA	GOLDLINE AMPLIFIER ASSEMBLY GUIDE FOR RESOLVER CABLES									
ISS.	ECN NO.		DATE	APP'D.							DWN. BY:	DATE	CHK. BY:	DATE	APP'D. BY:	DATE	SCALE	DWG. NO.	SHEET 7 OF 14	ISSUE
											EWR	05-18-92					1:1	A-93369		8

(W/SOLDERED MOTOR CONNECTOR)
 GOLDLINE RESOLVER CABLE WITH THERMOSTAT (GC-R-4/5-XX)

DWG. NO. SHEET 8 OF 14 | ISSUE
A-93369 | 8

PARTS LIST

CABLE				
ITEM #	DESCRIPTION	ID PART NUMBER	MANUFACTURER	
			NAME	PART NUMBER
#4	4 PAIR	A-81948	BELDEN	8725

MOTOR CONNECTOR AND ACCESSORIES				
ITEM #	DESCRIPTION	ID PART NUMBER	MANUFACTURER	
			NAME	PART NUMBER
#5	MOTOR HOUSING	A42867-1419	SOURIAU	851-06EC14-19S50

BDS4 C2 OR BDS5 C3 AND ACCESSORIES				
ITEM #	DESCRIPTION	ID PART NUMBER	MANUFACTURER	
			NAME	PART NUMBER
#1	12 POS. HOUSING	A-83908-012	MOLEX	39-01-2125
#3	CRIMP PIN	A-83909-002	MOLEX	39-00-0039
	CRIMP TOOL	N/A	MOLEX	HTR-60622

CONNECTION CHART

MOTOR CONNECTION ITEM #5	* CABLE ITEM #4	BDS4 C2 or BDS5 C3 ITEM #1	BDS4 C1 ITEM #2
TERMINAL A	RED	TERMINAL 7	N/C
TERMINAL B	BLACK	TERMINAL 1	
N/C	SHIELD	TERMINAL 8	
TERMINAL C	WHT/YEL	TERMINAL 3	
TERMINAL D	WHT/GRN	TERMINAL 9	
N/C	SHIELD	TERMINAL 2	
TERMINAL E	WHT/RED	TERMINAL 10	
TERMINAL F	WHT/BLK	TERMINAL 4	
N/C	SHIELD	TERMINAL 5	
TERMINAL N			
TERMINAL P		N/C	
TERMINAL R			
TERMINAL S		N/C	
TERMINAL T	GREEN	CUSTOMER	
TERMINAL U	WHITE	THERMOSTAT	
N/C	SHIELD	HOOK-UP	

SEE SHEET 5 AND 6 FOR CONNECTOR DETAILS.
 * THIS CABLE ASSEMBLY TO BE LABELED "GC-R-4/5-XX".

CABLE LENGTH

S	K	COPY CODE	ISS.	ECN NO.	DATE	APP'D.	Kollmorgen Industrial Drives RADFORD, VIRGINIA	GOLDLINE AMPLIFIER ASSEMBLY GUIDE FOR RESOLVER CABLES								
ISS.	ECN NO.	DATE	APP'D.					DWN. BY: EWR	DATE 08-12-92	CHK. BY:	DATE	APP'D. BY:	DATE	SCALE 1:1	DWG. NO. A-93369	SHEET 8 OF 14

(W/CRIMPED MOTOR CONNECTOR)
 GOLDLINE RESOLVER CABLE WITH THERMOSTAT AND BRAKE (GC-RB-4/5-XX)

PARTS LIST

CABLE				
ITEM #	DESCRIPTION	ID PART NUMBER	MANUFACTURER	
			NAME	PART NUMBER
#4	6 PAIR	A-96027-004	CAROL	C0573

MOTOR CONNECTOR AND ACCESSORIES				
ITEM #	DESCRIPTION	ID PART NUMBER	MANUFACTURER	
			NAME	PART NUMBER
#5	MOTOR HOUSING	A-84822	SOURIAU	851-06RX14-19S50-L
#7	CRIMP CONTACT	A-84823-002	SOURIAU	8500-1758
#6	FILLER PLUG	A-84823-001	SOURIAU	8500-4144A
	CRIMP TOOL	N/A	SOURIAU	MS3191-1

BDS4 C2 OR BDS5 C3 AND ACCESSORIES				
ITEM #	DESCRIPTION	ID PART NUMBER	MANUFACTURER	
			NAME	PART NUMBER
#1	12 POS. HOUSING	A-83908-012	MOLEX	39-01-2125
#3	CRIMP PIN	A-83909-002	MOLEX	39-00-0039
	CRIMP TOOL	N/A	MOLEX	HTR-60622

CONNECTION CHART

MOTOR CONNECTION ITEM #5	* CABLE ITEM #4	BDS4 C2 or BDS5 C3 ITEM #1	BDS4 C1 ITEM #2
TERMINAL A	RED 1	TERMINAL 7	N/C
TERMINAL B	BLK 1	TERMINAL 1	
N/C	SHIELD	TERMINAL 8	
TERMINAL C	RED 2	TERMINAL 3	
TERMINAL D	BLK 2	TERMINAL 9	
N/C	SHIELD	TERMINAL 2	
TERMINAL E	RED 3	TERMINAL 10	
TERMINAL F	BLK 3	TERMINAL 4	
N/C	SHIELD	TERMINAL 5	
TERMINAL N	RED 4	CUSTOMER	
TERMINAL P	BLK 4	BRAKE	
N/C	SHIELD	HOOK-UP	
TERMINAL R	SEE NOTE #1		
TERMINAL S		N/C	
TERMINAL T	RED 6	CUSTOMER	
TERMINAL U	BLK 6	THERMOSTAT	
N/C	SHIELD	HOOK-UP	

SEE SHEET 5 AND 6 FOR CONNECTOR DETAILS.
 * THIS CABLE ASSEMBLY TO BE LABELED "GC-RB-4/5-XX".

NOTE:
 1. RESOLVER END: CUT-OFF REMAINING PAIR 12.7MM (1/2") FROM CABLE JACKET AND FOLD BACK OVER JACKET, PLACE UNDER HEAT SHRINK.
 MOTOR END: CUT-OFF REMAINING PAIR EVEN WITH CABLE JACKET.

S		K		COPY CODE		ISS.	ECN NO.	DATE	APP'D.	Kollmorgen Industrial Drives RADFORD, VIRGINIA	GOLDLINE AMPLIFIER ASSEMBLY GUIDE FOR RESOLVER CABLES									
ISS.	ECN NO.	DATE	APP'D.								DWN. BY:	DATE	CHK. BY:	DATE	APP'D. BY:	DATE	SCALE	DWG. NO.	SHEET 9 OF 14	ISSUE
											EWR	05-18-92					1:1	A-93369		8

(W/SOLDERED MOTOR CONNECTOR)
 GOLDLINE RESOLVER CABLE WITH THERMOSTAT AND BRAKE (GC-RB-4/5-XX)

PARTS LIST

CABLE				
ITEM #	DESCRIPTION	ID PART NUMBER	MANUFACTURER	
			NAME	PART NUMBER
#4	6 PAIR	A-96027-004	CAROL	C0573

MOTOR CONNECTOR AND ACCESSORIES				
ITEM #	DESCRIPTION	ID PART NUMBER	MANUFACTURER	
			NAME	PART NUMBER
#5	MOTOR HOUSING	A42867-1419	SOURIAU	851-06EC14-19S50

BDS4 C2 OR BDS5 C3 AND ACCESSORIES				
ITEM #	DESCRIPTION	ID PART NUMBER	MANUFACTURER	
			NAME	PART NUMBER
#1	12 POS. HOUSING	A-83908-012	MOLEX	39-01-2125
#3	CRIMP PIN	A-83909-002	MOLEX	39-00-0039
	CRIMP TOOL	N/A	MOLEX	HTR-60622

CONNECTION CHART

MOTOR CONNECTION ITEM #5	* CABLE ITEM #4	BDS4 C2 or BDS5 C3 ITEM #1	BDS4 C1 ITEM #2
TERMINAL A	RED 1	TERMINAL 7	N/C
TERMINAL B	BLK 1	TERMINAL 1	
N/C	SHIELD	TERMINAL 8	
TERMINAL C	RED 2	TERMINAL 3	
TERMINAL D	BLK 2	TERMINAL 9	
N/C	SHIELD	TERMINAL 2	
TERMINAL E	RED 3	TERMINAL 10	
TERMINAL F	BLK 3	TERMINAL 4	
N/C	SHIELD	TERMINAL 5	
TERMINAL N	RED 4	CUSTOMER	
TERMINAL P	BLK 4	BRAKE	
N/C	SHIELD	HOOK-UP	
TERMINAL R	SEE NOTE #1		
TERMINAL S		N/C	
TERMINAL T	RED 6	CUSTOMER	
TERMINAL U	BLK 6	THERMOSTAT	
N/C	SHIELD	HOOK-UP	

SEE SHEET 5 AND 6 FOR CONNECTOR DETAILS.
 * THIS CABLE ASSEMBLY TO BE LABELED "GC-RB-4/5-XX".

NOTE:
 1. RESOLVER END: CUT-OFF REMAINING PAIR 12.7MM (1/2") FROM CABLE JACKET AND FOLD BACK OVER JACKET, PLACE UNDER HEAT SHRINK.
 MOTOR END: CUT-OFF REMAINING PAIR EVEN WITH CABLE JACKET.

Kollmorgen Industrial Drives
 RADFORD, VIRGINIA

GOLDLINE AMPLIFIER ASSEMBLY
 GUIDE FOR RESOLVER CABLES

DWN. BY: EWR	DATE 08-12-92	CHK. BY:	DATE	APP'D. BY:	DATE	SCALE 1:1	DWG. NO. A-93369	SHEET 10 OF 14	ISSUE 8
-----------------	------------------	----------	------	------------	------	--------------	---------------------	----------------	------------

ISS.	S	K	COPY CODE	ISS.	ECN NO.	DATE	APP'D.

(W/CRIMPED MOTOR CONNECTOR)
GOLDLINE RESOLVER CABLE WITH THERMOSTAT AND TACH (GC-RT-4/5-XX)

PARTS LIST

CABLE				
ITEM #	DESCRIPTION	ID PART NUMBER	MANUFACTURER	
			NAME	PART NUMBER
#4	6 PAIR	A-96027-004	CAROL	S0573

MOTOR CONNECTOR AND ACCESSORIES				
ITEM #	DESCRIPTION	ID PART NUMBER	MANUFACTURER	
			NAME	PART NUMBER
#5	MOTOR HOUSING	A-84822	SOURIAU	851-06RX14-19S50-L
#7	CRIMP CONTACT	A-84823-002	SOURIAU	8500-1758
#6	FILLER PLUG	A-84823-001	SOURIAU	8500-4144A
#4	CRIMP TOOL	N/A	SOURIAU	MS3191-1

BDS4 C2 OR BDS5 C3 AND ACCESSORIES				
ITEM #	DESCRIPTION	ID PART NUMBER	MANUFACTURER	
			NAME	PART NUMBER
#1	12 POS. HOUSING	A-83908-012	MOLEX	39-01-2125
#3	CRIMP PIN	A-83909-002	MOLEX	39-00-0039
	CRIMP TOOL	N/A	MOLEX	HTR-60622

BDS4 C1 AND ACCESSORIES				
ITEM #	DESCRIPTION	ID PART NUMBER	MANUFACTURER	
			NAME	PART NUMBER
#2	20 POS. HOUSING	A-83908-020	MOLEX	39-01-2205
#3	CRIMP PIN	A-83909-002	MOLEX	39-00-0039
	CRIMP TOOL	N/A	MOLEX	HTR-60622

CONNECTION CHART

MOTOR CONNECTION ITEM #5	* CABLE ITEM #4	BDS4 C2 or BDS5 C3 ITEM #1	BDS4 C1 ITEM #2
TERMINAL A	RED 1	TERMINAL 7	N/C
TERMINAL B	BLK 1	TERMINAL 1	TACH TERM. 12 TERM. 16 TERM. 5
N/C	SHIELD	TERMINAL 8	
TERMINAL C	RED 2	TERMINAL 3	
TERMINAL D	BLK 2	TERMINAL 9	
N/C	SHIELD	TERMINAL 2	
TERMINAL E	RED 3	TERMINAL 10	
TERMINAL F	BLK 3	TERMINAL 4	
N/C	SHIELD	TERMINAL 5	
TERMINAL N	SEE NOTE #1	N/C	
TERMINAL P			
TERMINAL R	RED 5		
TERMINAL S	BLK 5	N/C	
N/C	SHIELD		
TERMINAL T	RED 6	CUSTOMER THERMOSTAT HOOK-UP	N/C
TERMINAL U	BLK 6		
N/C	SHIELD		

SEE SHEET 3 AND 4 FOR CONNECTOR DETAILS.
 * THIS CABLE ASSEMBLY TO BE LABELED "GC-RT-4/5-XX".

NOTE:
 1. RESOLVER END: CUT-OFF REMAINING PAIR 12.7MM (1/2") FROM CABLE JACKET AND FOLD BACK OVER JACKET, PLACE UNDER HEAT SHRINK.
 MOTOR END: CUT-OFF REMAINING PAIR EVEN WITH CABLE JACKET.

Kollmorgen Industrial Drives
 RADFORD, VIRGINIA

GOLDLINE AMPLIFIER ASSEMBLY
 GUIDE FOR RESOLVER CABLES

DWN. BY: EWR	DATE 08-12-92	CHK. BY:	DATE	APP'D. BY:	DATE	SCALE 1:1	DWG. NO. A-93369	SHEET 11 OF 14	ISSUE 8
-----------------	------------------	----------	------	------------	------	--------------	---------------------	----------------	------------

ISS.	S	K	COPY CODE	ISS.	ECN NO.	DATE	APP'D.
	ECN NO.	DATE	APP'D.				

(W/SOLDERED MOTOR CONNECTOR)
 GOLDLINE RESOLVER CABLE WITH THERMOSTAT AND TACH (GC-RT-4/5-XX)

DWG. NO. SHT 12 OF 14 ISSUE
A-93369 8

PARTS LIST

CABLE				
ITEM #	DESCRIPTION	ID PART NUMBER	MANUFACTURER	
			NAME	PART NUMBER
#4	6 PAIR	A-96027-004	CAROL	S0573

MOTOR CONNECTOR AND ACCESSORIES				
ITEM #	DESCRIPTION	ID PART NUMBER	MANUFACTURER	
			NAME	PART NUMBER
#5	MOTOR HOUSING	A42867-1419	SOURIAU	851-06EC14-19S50

BDS4 C2 OR BDS5 C3 AND ACCESSORIES				
ITEM #	DESCRIPTION	ID PART NUMBER	MANUFACTURER	
			NAME	PART NUMBER
#1	12 POS. HOUSING	A-83908-012	MOLEX	39-01-2125
#3	CRIMP PIN	A-83909-002	MOLEX	39-00-0039
	CRIMP TOOL	N/A	MOLEX	HTR-60622

BDS4 C1 AND ACCESSORIES				
ITEM #	DESCRIPTION	ID PART NUMBER	MANUFACTURER	
			NAME	PART NUMBER
#2	20 POS. HOUSING	A-83908-020	MOLEX	39-01-2205
#3	CRIMP PIN	A-83909-002	MOLEX	39-00-0039
	CRIMP TOOL	N/A	MOLEX	HTR-60622

CONNECTION CHART

MOTOR CONNECTION ITEM #5	* CABLE ITEM #4	BDS4 C2 or BDS5 C3 ITEM #1	BDS4 C1 ITEM #2
TERMINAL A	RED 1	TERMINAL 7	N/C
TERMINAL B	BLK 1	TERMINAL 1	TACH TERM. 12 TERM. 16 TERM. 5
N/C	SHIELD	TERMINAL 8	
TERMINAL C	RED 2	TERMINAL 3	
TERMINAL D	BLK 2	TERMINAL 9	
N/C	SHIELD	TERMINAL 2	
TERMINAL E	RED 3	TERMINAL 10	
TERMINAL F	BLK 3	TERMINAL 4	
N/C	SHIELD	TERMINAL 5	
TERMINAL N	SEE NOTE #1	N/C	
TERMINAL P			
TERMINAL R	RED 5		
TERMINAL S	BLK 5	N/C	
N/C	SHIELD		
TERMINAL T	RED 6	CUSTOMER THERMOSTAT HOOK-UP	N/C
TERMINAL U	BLK 6		
N/C	SHIELD		

SEE SHEET 3 AND 4 FOR CONNECTOR DETAILS.

* THIS CABLE ASSEMBLY TO BE LABELED "GC-RT-4/5-XX".

NOTE:

- RESOLVER END: CUT-OFF REMAINING PAIR 12.7MM (1/2") FROM CABLE JACKET AND FOLD BACK OVER JACKET, PLACE UNDER HEAT SHRINK. MOTOR END: CUT-OFF REMAINING PAIR EVEN WITH CABLE JACKET.

CABLE LENGTH

S		K		COPY CODE		ISS.	ECN NO.	DATE	APP'D.	Kollmorgen Industrial Drives RADFORD, VIRGINIA	GOLDLINE AMPLIFIER ASSEMBLY GUIDE FOR RESOLVER CABLES								
ISS.	ECN NO.	DATE	APP'D.								DWN. BY: EWR	DATE 08-12-92	CHK. BY:	DATE	APP'D. BY:	DATE	SCALE 1:1	DWG. NO. A-93369	SHEET 12 OF 14

(W/CRIMPED MOTOR CONNECTOR)

GOLDLINE RESOLVER CABLE WITH THERMOSTAT, BRAKE, AND TACH (GC-RBT-4/5-XX)

PARTS LIST

CABLE				
ITEM #	DESCRIPTION	ID PART NUMBER	MANUFACTURER	
			NAME	PART NUMBER
#4	6 PAIR	A-96027-004	CAROL	S0573

MOTOR CONNECTOR AND ACCESSORIES				
ITEM #	DESCRIPTION	ID PART NUMBER	MANUFACTURER	
			NAME	PART NUMBER
#5	MOTOR HOUSING	A-84822	SOURIAU	851-06RX14-19S50-L
#7	CRIMP CONTACT	A-84823-002	SOURIAU	8500-1758
#6	FILLER PLUG	A-84823-001	SOURIAU	8500-4144A
	CRIMP TOOL	N/A	SOURIAU	MS3191-1

BDS4 C2 OR BDS5 C3 AND ACCESSORIES				
ITEM #	DESCRIPTION	ID PART NUMBER	MANUFACTURER	
			NAME	PART NUMBER
#1	12 POS. HOUSING	A-83908-012	MOLEX	39-01-2125
#3	CRIMP PIN	A-83909-002	MOLEX	39-00-0039
	CRIMP TOOL	N/A	MOLEX	HTR-60622

BDS4 C1 AND ACCESSORIES				
ITEM #	DESCRIPTION	ID PART NUMBER	MANUFACTURER	
			NAME	PART NUMBER
#2	20 POS. HOUSING	A-83908-020	MOLEX	39-01-2205
#3	CRIMP PIN	A-83909-002	MOLEX	39-00-0039
	CRIMP TOOL	N/A	MOLEX	HTR-60622

CONNECTION CHART

MOTOR CONNECTION ITEM #5	* CABLE ITEM #4	BDS4 C2 or BDS5 C3 ITEM #1	BDS4 C1 ITEM #2
TERMINAL A	RED 1	TERMINAL 7	N/C
TERMINAL B	BLK 1	TERMINAL 1	
N/C	SHIELD	TERMINAL 8	
TERMINAL C	RED 2	TERMINAL 3	
TERMINAL D	BLK 2	TERMINAL 9	
N/C	SHIELD	TERMINAL 2	
TERMINAL E	RED 3	TERMINAL 10	
TERMINAL F	BLK 3	TERMINAL 4	
N/C	SHIELD	TERMINAL 5	
TERMINAL N	RED 4	CUSTOMER	
TERMINAL P	BLK 4	BRAKE	
N/C	SHIELD	HOOK-UP	
TERMINAL R	RED 5		
TERMINAL S	BLK 5	N/C	A
N/C	SHIELD		H
TERMINAL T	RED 6	CUSTOMER	
TERMINAL U	BLK 6	THERMOSTAT	
N/C	SHIELD	HOOK-UP	N/C

SEE SHEET 3 AND 4 FOR CONNECTOR DETAILS.
 * THIS CABLE ASSEMBLY TO BE LABELED "GC-RBT-4/5-XX".

CABLE LENGTH

ISS.	S	K	COPY CODE	ISS.	ECN NO.	DATE	APP'D.

Kollmorgen Industrial Drives
 RADFORD, VIRGINIA

GOLDLINE AMPLIFIER ASSEMBLY
 GUIDE FOR RESOLVER CABLES

DWN. BY:	DATE	CHK. BY:	DATE	APP'D. BY:	DATE	SCALE	DWG. NO.	SHEET 13 OF 14	ISSUE
EWR	08-12-92					1:1	A-93369		8

(W/SOLDERED MOTOR CONNECTOR)
 GOLDLINE RESOLVER CABLE WITH THERMOSTAT, BRAKE, AND TACH (GC-RBT-4/5-XX)

PARTS LIST

CABLE				
ITEM #	DESCRIPTION	ID PART NUMBER	MANUFACTURER	
			NAME	PART NUMBER
#4	6 PAIR	A-96027-004	CAROL	S0573

MOTOR CONNECTOR AND ACCESSORIES				
ITEM #	DESCRIPTION	ID PART NUMBER	MANUFACTURER	
			NAME	PART NUMBER
#5	MOTOR HOUSING	A42867-1419	SOURIAU	851-06EC14-19S50

BDS4 C2 OR BDS5 C3 AND ACCESSORIES				
ITEM #	DESCRIPTION	ID PART NUMBER	MANUFACTURER	
			NAME	PART NUMBER
#1	12 POS. HOUSING	A-83908-012	MOLEX	39-01-2125
#3	CRIMP PIN	A-83909-002	MOLEX	39-00-0039
	CRIMP TOOL	N/A	MOLEX	HTR-60622

BDS4 C1 AND ACCESSORIES				
ITEM #	DESCRIPTION	ID PART NUMBER	MANUFACTURER	
			NAME	PART NUMBER
#2	20 POS. HOUSING	A-83908-020	MOLEX	39-01-2205
#3	CRIMP PIN	A-83909-002	MOLEX	39-00-0039
	CRIMP TOOL	N/A	MOLEX	HTR-60622

CONNECTION CHART

MOTOR CONNECTION ITEM #5	* CABLE ITEM #4	BDS4 C2 or BDS5 C3 ITEM #1	BDS4 C1 ITEM #2
TERMINAL A	RED 1	TERMINAL 7	N/C
TERMINAL B	BLK 1	TERMINAL 1	
N/C	SHIELD	TERMINAL 8	
TERMINAL C	RED 2	TERMINAL 3	
TERMINAL D	BLK 2	TERMINAL 9	
N/C	SHIELD	TERMINAL 2	
TERMINAL E	RED 3	TERMINAL 10	
TERMINAL F	BLK 3	TERMINAL 4	
N/C	SHIELD	TERMINAL 5	
TERMINAL N	RED 4	CUSTOMER	
TERMINAL P	BLK 4	BRAKE	
N/C	SHIELD	HOOK-UP	
TERMINAL R	RED 5		
TERMINAL S	BLK 5	N/C	A
N/C	SHIELD		H
TERMINAL T	RED 6	CUSTOMER	} TERM. 12 TERM. 16 TERM. 5
TERMINAL U	BLK 6	THERMOSTAT	
N/C	SHIELD	HOOK-UP	N/C

SEE SHEET 3 AND 4 FOR CONNECTOR DETAILS.
 * THIS CABLE ASSEMBLY TO BE LABELED "GC-RBT-4/5-XX".

CABLE LENGTH

S		K		COPY CODE		ISS.	ECN NO.	DATE	APP'D.	Kollmorgen Industrial Drives RADFORD, VIRGINIA	GOLDLINE AMPLIFIER ASSEMBLY GUIDE FOR RESOLVER CABLES								
ISS.	ECN NO.	DATE	APP'D.								DWN. BY: EWR	DATE 05-18-92	CHK. BY:	DATE	APP'D. BY:	DATE	SCALE 1:1	DWG. NO. A-93369	SHEET 14 OF 14

UNLESS OTHERWISE SPECIFIED
ANG. DIM. ±1 DEGREE

XX DEC. PLACES ±.015 IN.
XXX DEC. PLACES ±.005 IN.

DO NOT SCALE DWG. USE DIMENSIONS ONLY.
ALL DIMENSIONS ARE INCHES UNLESS OTHERWISE SPECIFIED

DWG. NO.
A-93409

ISSUE
1

C1
(SEE
NOTE 5)

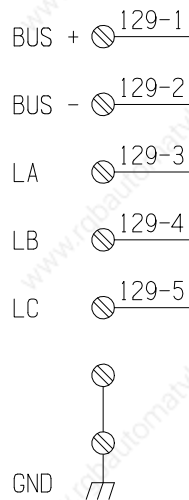
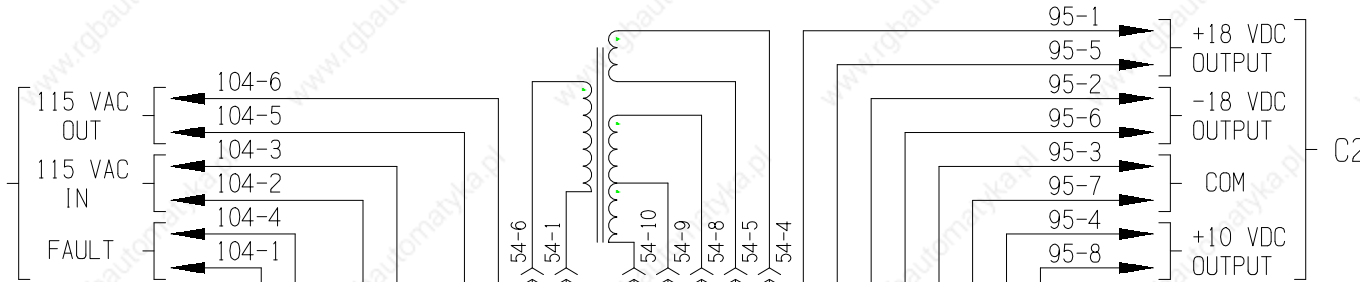

POWER SUPPLY/REGEN CARD
PSR-PS4-XXXX

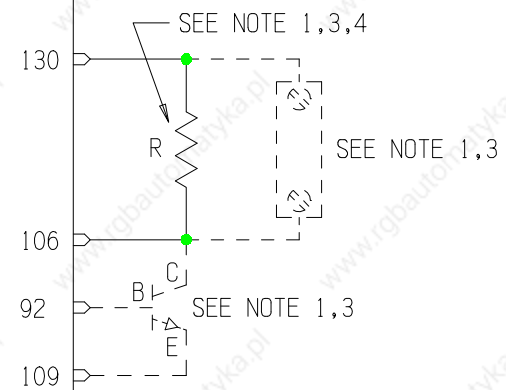
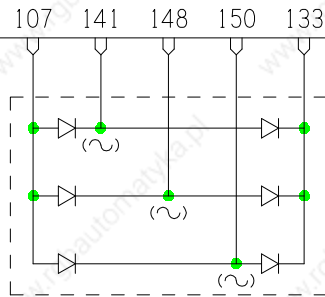

NOTE:

- 1 - MODELS WITH INTERNAL REGEN OMIT TERMINAL BLOCK AND TRANSISTOR MODULE.
- 2 - OMIT R ON MODELS WITH EXTERNAL REGEN.
- 3 - OMIT ON MODELS WITHOUT REGEN.
- 4 - PSR4/5A INTERNAL R VALUE
-112 7.5ohm 100w
-120 7.5ohm 100w
-212 12.5ohm 100w
-220 12.5ohm 100w
- 5 - 115 VAC IN/OUT ON STANDARD MODEL
230 VAC IN/OUT ON SPECIAL

CAD DWG. (D-112)

		S	COPY CODE
--	--	---	-----------

ISS.	ECN NO.	DATE	APP'D.	ISS.	ECN NO.	DATE	APP'D.



INDUSTRIAL DRIVES

RADFORD, VIRGINIA
A KOLLMORGEN DIVISION

PSR4/5A
INTERNAL SCHEMATIC

DWN. BY: LLS	DATE 05-18-92	CHK. BY:	DATE	APP'D. BY:	DATE	SCALE 1/1	DWG. NO. A-93409	ISSUE 1
-----------------	------------------	----------	------	------------	------	--------------	----------------------------	------------

THIS DRAWING CONTAINS THE INFORMATION NECESSARY TO FABRICATE MOTOR CABLES TO BE USED WITH BDS4/5-30, 40, & 55 OR S/D-30 & 55 AMP UNITS WHEN USED ON THE FOLLOWING MOTORS, IF THEY HAVE BAYONET TYPE CONNECTORS.

FOR 406C, 604B, 604C, 606B, 606C, & 606D MOTORS: SEE SHEET 3 or 4
 802A, 802B, 804A, 804B, & 806A MOTORS: SEE SHEET 5 or 6
 804C & 806B MOTORS: SEE SHEET 7 or 8

DASH NO.	CABLE LENGTH		DASH NO.	CABLE LENGTH		DASH NO.	CABLE LENGTH	
	METERS	FEET		METERS	FEET		METERS	FEET
-003	3	10	-024	24	80	-045	45	150
-006	6	20	-027	27	90	-048	48	160
-009	9	30	-030	30	100	-051	51	170
-012	12	40	-033	33	110	-054	54	180
-015	15	50	-036	36	120	-057	57	190
-018	18	60	-039	39	130	-060	60	200
-021	21	70	-042	42	140			

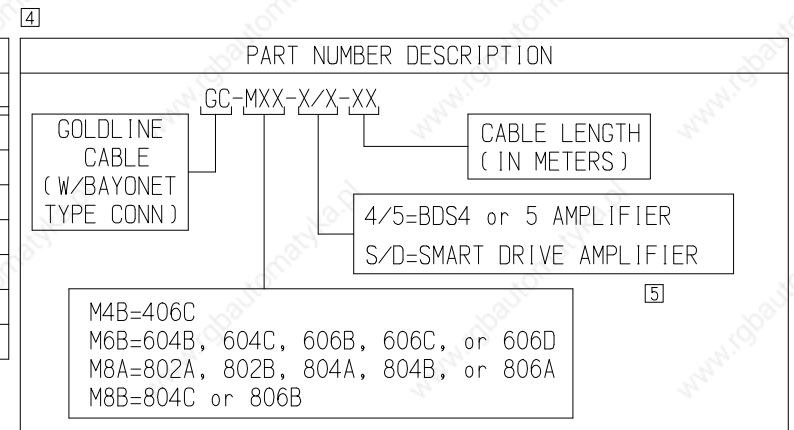

ISS.	ECN NO.	DATE	APP'D.	ISS.	ECN NO.	DATE	APP'D.	Kollmorgen Industrial Drives RADFORD, VIRGINIA				GOLDLINE AMPLIFIER ASSEMBLY GUIDE FOR MOTOR CABLES (30, 40, & 55 AMP)					
6	86599 TDG	03-13-95	SCM	3	84998 EWR	2-25-93	FDO									DRAWN BY:	DATE
7	88241 RRH	1-21-97	FMJ	4	85611 TDC	1-26-94	FDO	EWR	08-28-92					1:1	A-93414		8
8	303198 JK	9-17-99		5	85963 MAW	07-12-94	SCM										

8

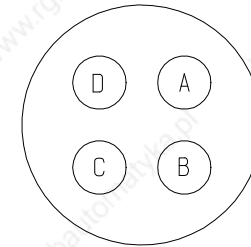
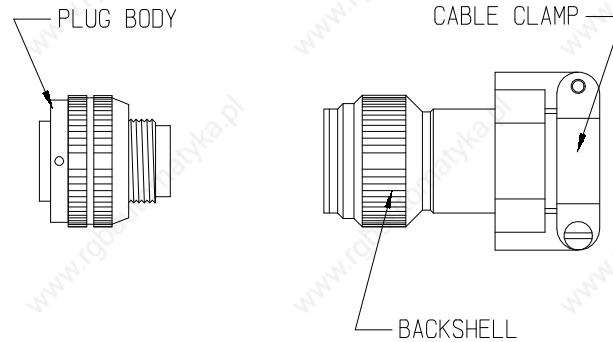

DETAIL A - A

CONNECTOR ASSEMBLY PROCEDURE

STEP 1 USE STRIPPING PLIERS TO STRIP INSULATION 4.57MM (.18") FROM EACH WIRE, BOTH ENDS.

STEP 2 A FOR CRIMP CONNECTORS:

- B INSERT WIRES INTO THE CRIMP CONTACTS AND CRIMP. (WHEN CRIMP REDUCTION SLEEVES ARE USED, WIRES ARE TO BE INSERTED IN SLEEVE FIRST!)
- C INSERT THE CRIMP CONTACTS INTO THE PLUG BODY, WITH USE OF GUIDE PINS, CONNECT AS SHOWN ON FOLLOWING SHEETS.

STEP 2 A FOR SOLDER CONNECTORS:

INSERT WIRES INTO THE SOLDER CUPS AND SOLDER.

- STEP 3 A SLIDE THE BACKSHELL ALONG THE WIRES TO PLUG BODY,
- B HOLD PLUG BODY SECURELY AND SCREW BACKSHELL ONTO PLUG BODY,
- C TIGHTEN CABLE CLAMP.
- D PLACE LABEL IN APPROXIMATE LOCATION AS SHOWN ON FOLLOWING SHEETS.

NOTE:

- 1. FOR CABLE ASSEMBLY GC-M4B or M6B-X/X-XX...SEE SHEET #3 & 4
- FOR CABLE ASSEMBLY GC-M8A-X/X-XX.....SEE SHEET #5 & 6
- FOR CABLE ASSEMBLY GC-M8B-X/X-XX.....SEE SHEET #7 & 8

CAD DWG.

			K	COPY CODE	ISS.	ECN NO.	DATE	APP'D.	Kollmorgen Industrial Drives RADFORD, VIRGINIA	GOLDLINE AMPLIFIER ASSEMBLY GUIDE FOR MOTOR CABLES (30, 40, & 55 AMP)								
ISS.	ECN NO.	DATE	APP'D.						DRAWN BY: EWR	DATE 08-28-92	CHK. BY:	DATE	APP'D. BY:	DATE	SCALE 1:1	DWG. NO. A-93414	SHEET 2 OF 8	ISSUE 8

(W/CRIMPED CONNECTOR)
GOLDLINE MOTOR CABLE (406C, 604B, 604C, 606B, 606C, & 606D MOTOR)

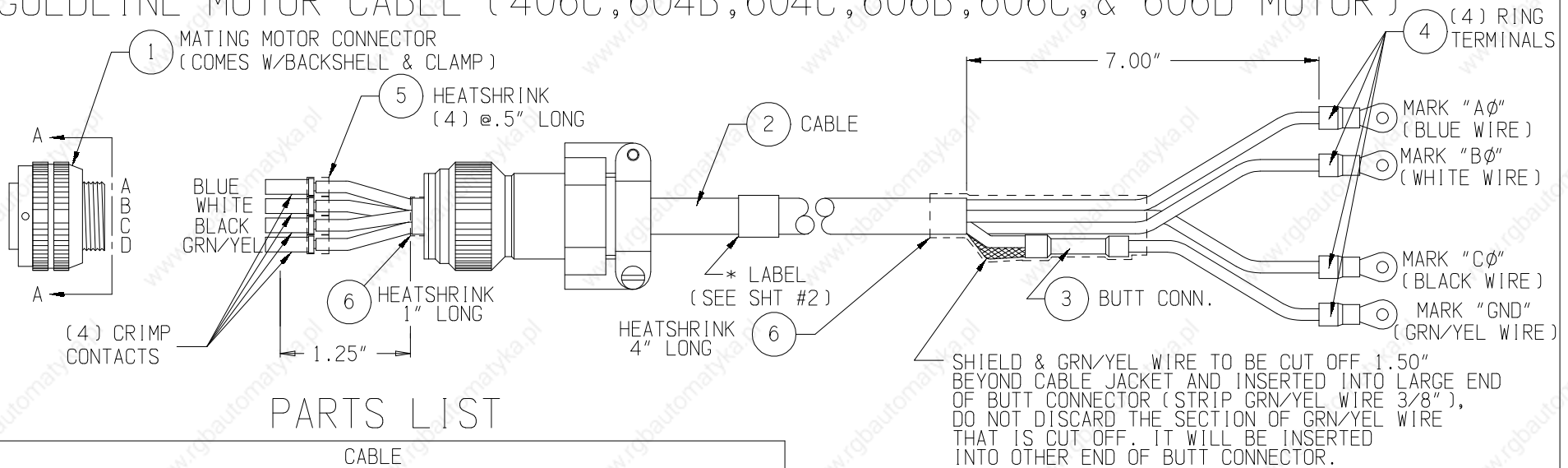

PARTS LIST

CABLE				
ITEM #	DESCRIPTION	ID PART NUMBER	MANUFACTURER	
			NAME	PART NUMBER
#2	4 CONDUCTOR #8 AWG	97941-008	C & M	

MOTOR CONNECTOR AND ACCESSORIES				
ITEM #	DESCRIPTION	ID PART NUMBER	MANUFACTURER	
			NAME	PART NUMBER
#1	MOTOR PLUG	A-98030-2222		
	BACKSHELL	A-69149-2016		
	CRIMP TOOL	N/A	VEAM	AF8
	INSERTION TOOL	N/A	VEAM	46736-6
	GUIDE PINS	N/A	VEAM	27977-12T50

ITEM #	DESCRIPTION	ID PART NUMBER	MANUFACTURER	
			NAME	PART NUMBER
#4	RING TERMINAL	A-79406-002	HOLLINGSWORTH	R3027BF
	CRIMP TOOL	N/A	HOLLINGSWORTH	#H6E
#3	BUTT CONN.	A-80654-004	HOLLINGSWORTH	B4047BF
#5	3/16" SHRINK TUB.	G-15265	RAYCHEM	RNF-100-1-3/16"
#6	3/4" SHRINK TUB.	G-17634	RAYCHEM	RNF-100-1-3/4"

* THIS CABLE ASSEMBLY TO BE LABELED "GC-M4B or GC-M6B-X/X-XX".

- ④ 4/5=BDS4 or 5 AMPLIFIER
- ⑤ S/D=SMART DRIVE AMPLIFIER

CABLE LENGTH
(IN METERS)

ISS.	ECN NO.	DATE	APP'D.	ISS.	ECN NO.	DATE	APP'D.	Kollmorgen Industrial Drives RADFORD, VIRGINIA	GOLDLINE AMPLIFIER ASSEMBLY GUIDE FOR MOTOR CABLES (30, 40, & 55 AMP)								
									DWN. BY: EWR	DATE: 08-28-92	CHK. BY:	DATE:	APP'D. BY:	DATE:	SCALE: 1:1	DWG. NO. A-93414	SHEET 3 OF 8

(W/SOLDERED CONNECTOR)
GOLDLINE MOTOR CABLE (406C, 604B, 604C, 606B, 606C, & 606D MOTOR)

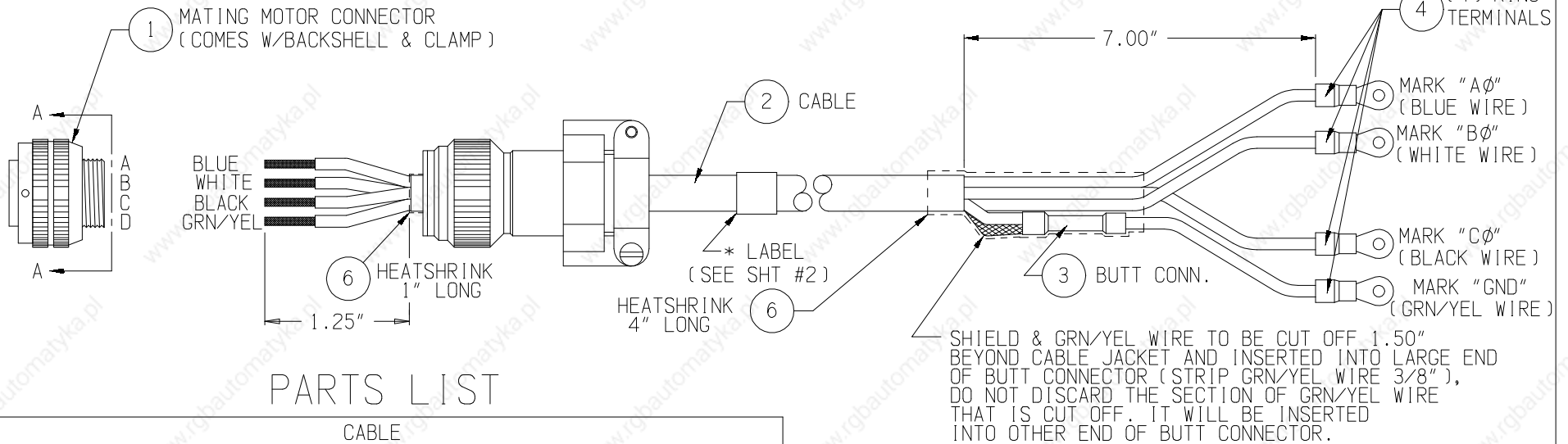

PARTS LIST

CABLE				
ITEM #	DESCRIPTION	ID PART NUMBER	MANUFACTURER	
			NAME	PART NUMBER
#2	4 CONDUCTOR #8 AWG	A-97941-008	C & M	

MOTOR CONNECTOR AND ACCESSORIES				
ITEM #	DESCRIPTION	ID PART NUMBER	MANUFACTURER	
			NAME	PART NUMBER
#1	MOTOR PLUG	A-43642	VEAM	CIR 06F-22-22S

ITEM #	DESCRIPTION	ID PART NUMBER	MANUFACTURER	
			NAME	PART NUMBER
#4	RING TERMINAL	A-79406-002	HOLLINGSWORTH	R3027BF
	CRIMP TOOL	N/A	HOLLINGSWORTH	#H6E
#3	BUTT CONN.	A-80654-004	HOLLINGSWORTH	B4047BF
#6	3/4" SHRINK TUB.	G-17634	RAYCHEM	RNF-100-1-3/4"

* THIS CABLE ASSEMBLY TO BE LABELED "GC-M4B or GC-M6B-X/X-XX".

- ④ 4/5=BDS4 or 5 AMPLIFIER
- ⑤ S/D=SMART DRIVE AMPLIFIER

CABLE LENGTH
(IN METERS)

(W/CRIMPED CONNECTOR)
GOLDLINE MOTOR CABLE (802A, 802B, 804A, 804B, & 806A MOTOR)

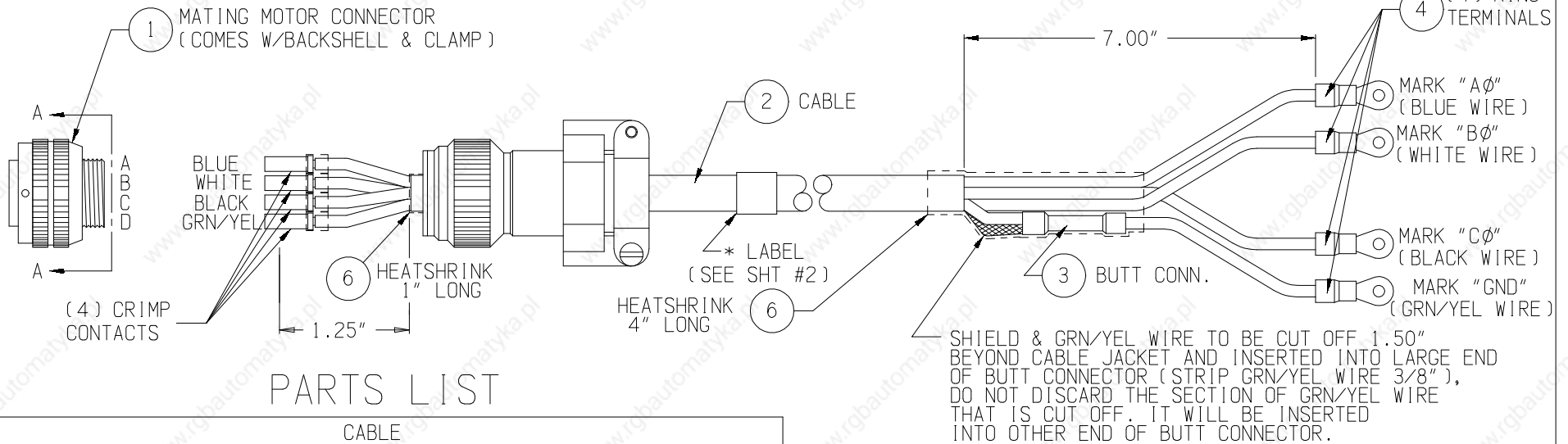

PARTS LIST

CABLE				
ITEM #	DESCRIPTION	ID PART NUMBER	MANUFACTURER	
			NAME	PART NUMBER
#2	4 CONDUCTOR #8 AWG	A-97941-008	C & M	

MOTOR CONNECTOR AND ACCESSORIES				
ITEM #	DESCRIPTION	ID PART NUMBER	MANUFACTURER	
			NAME	PART NUMBER
#1	MOTOR PLUG	A-93338	VEAM	CIR 06F-32-17S-F80
	CRIMP REDUCER	A-84740-007	VEAM	LV242999-112T9
	CRIMP TOOL	N/A	VEAM	AF8
	INSERTION TOOL	N/A	VEAM	46736-6
	GUIDE PINS	N/A	VEAM	27977-12T50

ITEM #	DESCRIPTION	ID PART NUMBER	MANUFACTURER	
			NAME	PART NUMBER
#4	RING TERMINAL	A-79406-002	HOLLINGSWORTH	R3027BF
	CRIMP TOOL	N/A	HOLLINGSWORTH	#H6E
#3	BUTT CONN.	A-80654-004	HOLLINGSWORTH	B4047BF
#6	3/4" SHRINK TUB.	G-17634	RAYCHEM	RNF-100-1-3/4"

* THIS CABLE ASSEMBLY TO BE LABELED "GC-M8A-X/X-XX".

- 4 4/5=BDS4 or 5 AMPLIFIER
- 5 S/D=SMART DRIVE AMPLIFIER

CABLE LENGTH
(IN METERS)

ISS.	ECN NO.	DATE	APP'D.	ISS.	ECN NO.	DATE	APP'D.	Kollmorgen Industrial Drives RADFORD, VIRGINIA	GOLDLINE AMPLIFIER ASSEMBLY GUIDE FOR MOTOR CABLES (30, 40, & 55 AMP)								
									DWN. BY: EWR	DATE 08-28-92	CHK. BY:	DATE	APP'D. BY:	DATE	SCALE 1:1	DWG. NO. A-93414	SHEET 5 OF 8

(W/SOLDERED CONNECTOR)
GOLDLINE MOTOR CABLE (802A, 802B, 804A, 804B, & 806A MOTOR)

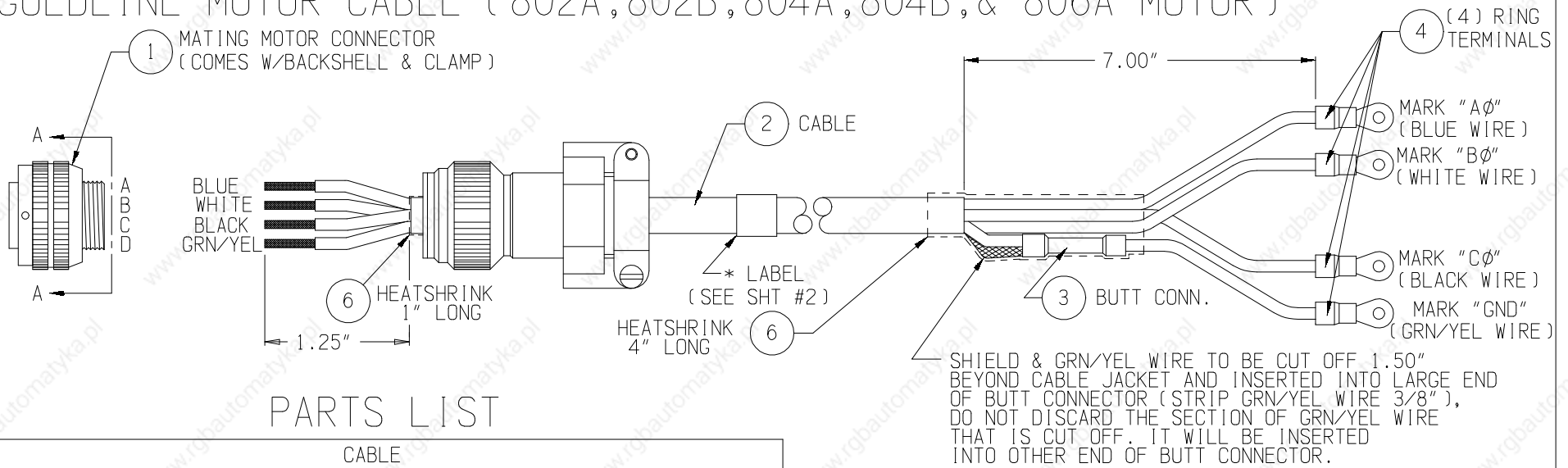

PARTS LIST

CABLE				
ITEM #	DESCRIPTION	ID PART NUMBER	MANUFACTURER	
			NAME	PART NUMBER
#2	4 CONDUCTOR #8 AWG	A-97941-008	C & M	

MOTOR CONNECTOR AND ACCESSORIES				
ITEM #	DESCRIPTION	ID PART NUMBER	MANUFACTURER	
			NAME	PART NUMBER
#1	MOTOR PLUG	A-43828	VEAM	CIR 06F-32-17S

ITEM #	DESCRIPTION	ID PART NUMBER	MANUFACTURER	
			NAME	PART NUMBER
#4	RING TERMINAL	A-79406-002	HOLLINGSWORTH	R3027BF
	CRIMP TOOL	N/A	HOLLINGSWORTH	#H6E
#3	BUTT CONN.	A-80654-004	HOLLINGSWORTH	B4047BF
#6	3/4" SHRINK TUB.	G-17634	RAYCHEM	RNF-100-1-3/4"

* THIS CABLE ASSEMBLY TO BE LABELED "GC-M8A-X/X-XX".

- ④ 4/5=BDS4 or 5 AMPLIFIER
- ⑤ S/D=SMART DRIVE AMPLIFIER

CABLE LENGTH
(IN METERS)

ISS.	ECN NO.	DATE	APP'D.	ISS.	ECN NO.	DATE	APP'D.	Kollmorgen Industrial Drives RADFORD, VIRGINIA	GOLDLINE AMPLIFIER ASSEMBLY GUIDE FOR MOTOR CABLES (30, 40, & 55 AMP)								
									DWN. BY: EWR	DATE: 08-28-92	CHK. BY:	DATE:	APP'D. BY:	DATE:	SCALE: 1:1	DWG. NO. A-93414	SHEET 6 OF 8

(W/CRIMPED CONNECTOR)
GOLDLINE MOTOR CABLE (804C & 806B MOTOR)

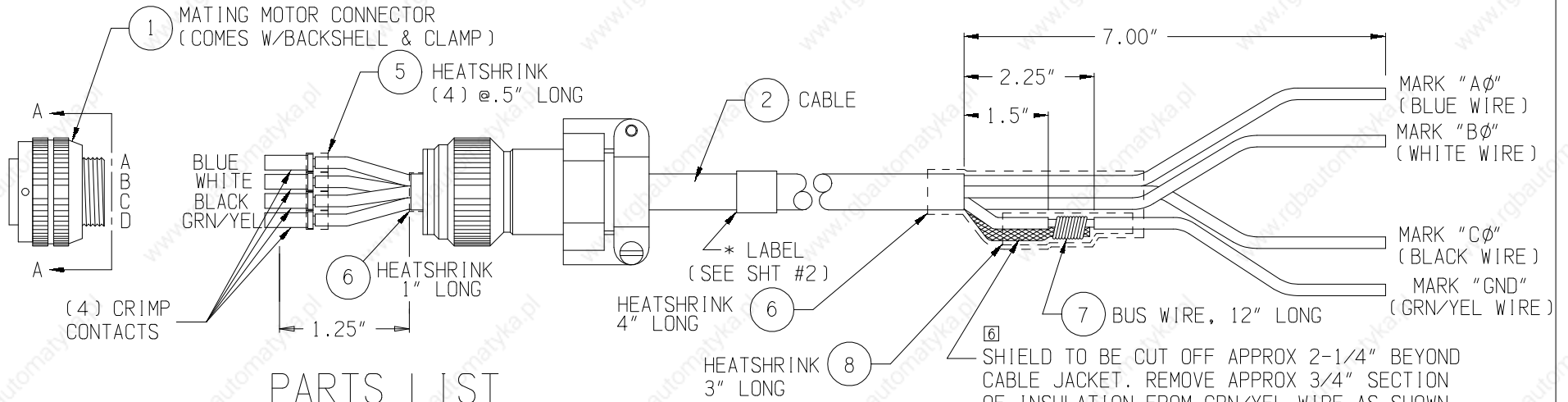

PARTS LIST

CABLE				
ITEM #	DESCRIPTION	ID PART NUMBER	MANUFACTURER	
			NAME	PART NUMBER
#2	4 CONDUCTOR #4 AWG	A-97941-004	OMNI	ID0404TBTPR-FLEX

MOTOR CONNECTOR AND ACCESSORIES				
ITEM #	DESCRIPTION	ID PART NUMBER	MANUFACTURER	
			NAME	PART NUMBER
#1	MOTOR PLUG	A-93338	VEAM	CIR 06F-32-17S-F80
	CRIMP TOOL	N/A	VEAM	AF8
	INSERTION TOOL	N/A	VEAM	46736-6
	GUIDE PINS	N/A	VEAM	27977-12T50

ITEM #	DESCRIPTION	ID PART NUMBER	MANUFACTURER	
			NAME	PART NUMBER
#5	3/16" SHRINK TUB.	G-15265	RAYCHEM	RNF-100-1-3/16"
#6	3/4" SHRINK TUB.	G-17634	RAYCHEM	RNF-100-1-3/4"
#7	#20 BUS WIRE	H-15088	ALPHA	297
#8	5/8" SHRINK TUB.	H-15577	RAYCHEM	RNF-100-1-5/8"

* THIS CABLE ASSEMBLY TO BE LABELED "GC-M8B-X/X-XX".

- ④ 4/5=BDS4 or 5 AMPLIFIER
- ⑤ S/D=SMART DRIVE AMPLIFIER

CABLE LENGTH (IN METERS)

ISS.	ECN NO.	DATE	APP'D.	ISS.	ECN NO.	DATE	APP'D.	Kollmorgen Industrial Drives RADFORD, VIRGINIA	GOLDLINE AMPLIFIER ASSEMBLY GUIDE FOR MOTOR CABLES (30, 40, & 55 AMP)								
									DWN. BY: EWR	DATE: 08-28-92	CHK. BY:	DATE:	APP'D. BY:	DATE:	SCALE: 1:1	DWG. NO. A-93414	SHEET 7 OF 8

(W/SOLDERED CONNECTOR)
GOLDLINE MOTOR CABLE (804C & 806B MOTOR)

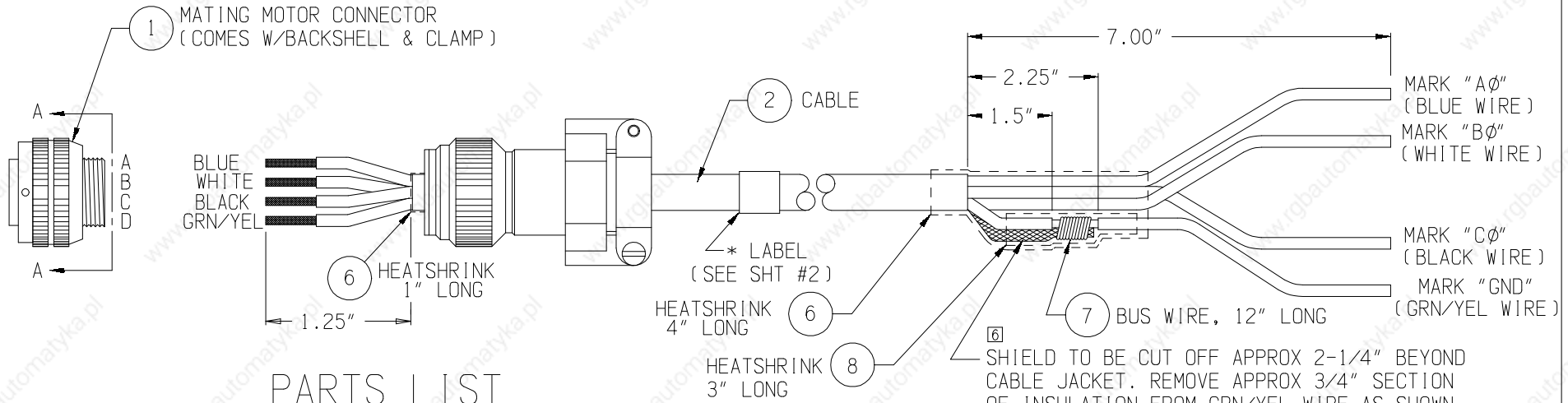

PARTS LIST

CABLE				
ITEM #	DESCRIPTION	ID PART NUMBER	MANUFACTURER	
			NAME	PART NUMBER
#2	4 CONDUCTOR #4 AWG	A-97941-004	OMNI	ID0404TBTPR-FLEX

MOTOR CONNECTOR AND ACCESSORIES				
ITEM #	DESCRIPTION	ID PART NUMBER	MANUFACTURER	
			NAME	PART NUMBER
#1	MOTOR PLUG	A-43828	VEAM	CIR 06F-32-17S

ITEM #	DESCRIPTION	ID PART NUMBER	MANUFACTURER	
			NAME	PART NUMBER
#6	3/4" SHRINK TUB.	G-17634	RAYCHEM	RNF-100-1-3/4"
#7	#20 BUS WIRE	H-15088	ALPHA	297
#8	5/8" SHRINK TUB.	H-15577	RAYCHEM	RNF-100-1-5/8"

* THIS CABLE ASSEMBLY TO BE LABELED "GC-M8B-X/X-XX".

- 4 4/5=BDS4 or 5 AMPLIFIER
- 5 S/D=SMART DRIVE AMPLIFIER

CABLE LENGTH (IN METERS)

ISS.	ECN NO.	DATE	APP'D.	ISS.	ECN NO.	DATE	APP'D.	Kollmorgen Industrial Drives RADFORD, VIRGINIA	GOLDLINE AMPLIFIER ASSEMBLY GUIDE FOR MOTOR CABLES (30, 40, & 55 AMP)	DWN. BY:	DATE	CHK. BY:	DATE	APP'D. BY:	DATE	SCALE	DWG. NO.	SHEET 8 OF 8	ISSUE
										EWR	08-28-92							1:1	A-93414

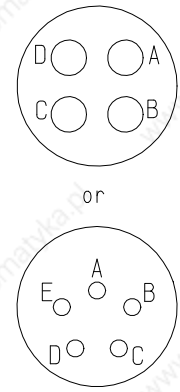
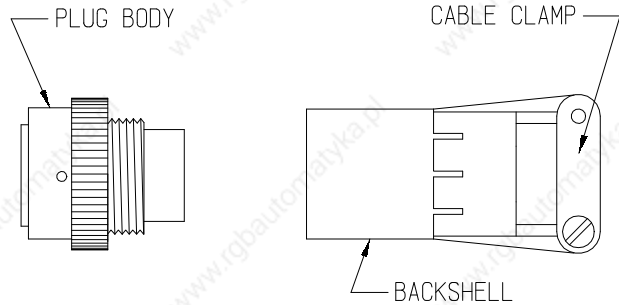

DETAIL A - A

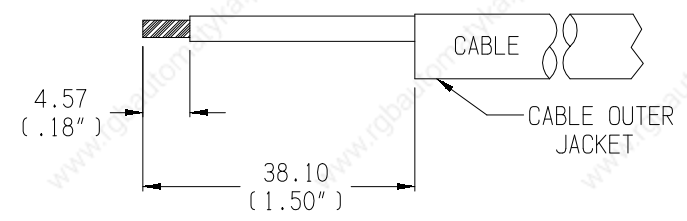

CONNECTOR ASSEMBLY PROCEDURE

- STEP 1** BEFORE ANY OUTER JACKET HAS BEEN REMOVED FROM THE CABLE, SLIDE THE FOLLOWING ITEMS ONTO THE CABLE: 12.7MM (1/2") SHRINK TUBING, BACKSHELL AND 15.88MM (5/8") SHRINK TUBING.
- STEP 2** STRIP THE OUTER CABLE JACKET BACK 38.1MM (1.5"). THIS WILL EXPOSE THE SHIELD AROUND THE INDIVIDUAL WIRES. (THE DIAGRAM ONLY SHOWS ONE WIRE FOR CLARITY)
- STEP 3 A** CUT & DISCARD THE SHIELD FROM THIS END OF CABLE.
B USE STRIPPING PLIERS TO STRIP INSULATION 4.57MM (.18") FROM INDIVIDUAL WIRES.
- STEP 4 A** FOR CRIMP CONNECTORS:
B INSERT WIRES INTO THE CRIMP CONTACTS AND CRIMP.
C INSERT THE CRIMP CONTACTS INTO THE PLUG BODY, WITH USE OF GUIDE PINS, ACCORDING TO THE CONNECTION CHART.
- STEP 4 A** FOR SOLDER CONNECTORS:
 INSERT WIRES INTO THE SOLDER CUPS AND SOLDER.

- STEP 5 A** POSITION THE 5/8" HEAT SHRINK TUBING AND APPLY HEAT TO SHRINK TUBING, AS SHOWN ON FOLLOWING SHEETS.
B SLIDE THE BACKSHELL ALONG THE CABLE TO PLUG BODY.
C HOLD PLUG BODY SECURELY AND SCREW BACKSHELL ONTO PLUG BODY,
D TIGHTEN CABLE CLAMP.
E POSITION THE 1/2" SHRINK TUBING AND APPLY HEAT TO SHRINK TUBING, AS SHOWN ON FOLLOWING SHEETS.
- STEP 6** PLACE LABEL IN APPROXIMATE LOCATION AS SHOWN ON FOLLOWING SHEETS.

NOTE: 1. FOR CABLE ASSEMBLY GC-M1 or M2A-X/X-XX...SEE SHEET #3 OR 4
 FOR CABLE ASSEMBLY GC-M2B or M4A-X/X-XX...SEE SHEET #5 OR 6
 FOR CABLE ASSEMBLY GC-M6A-X/X-XX...SEE SHEET #7 OR 8

CAD DWG.

			K	COPY CODE	ISS.	ECN NO.	DATE	APP'D.	Kollmorgen Industrial Drives			GOLDLINE AMPLIFIER ASSEMBLY GUIDE FOR MOTOR CABLES (3 THRU 20 AMP)			
ISS.	ECN NO.	DATE	APP'D.						RADFORD, VIRGINIA			SCALE	DWG. NO.	SHEET 2 OF 8	ISSUE
+									EWR	05-18-92		1:1	A-93421		7

(W/CRIMPED CONNECTOR)
 GOLDLINE MOTOR CABLE (FOR 10X & 20X, EXC. 206D MOTOR)

DWG. NO. SHEET 3 OF 8 ISSUE
 A-93421 7

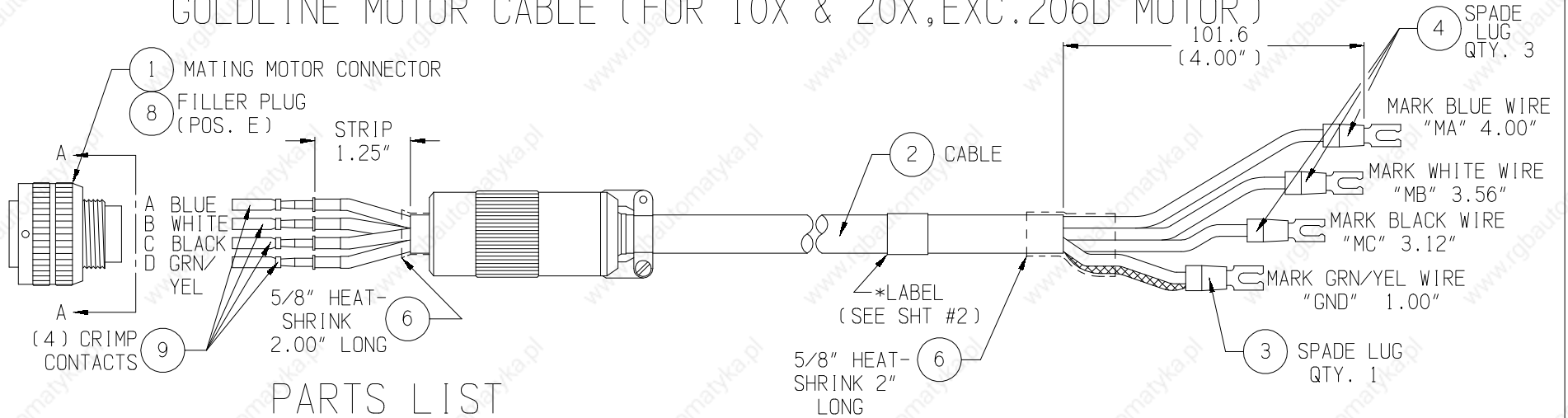

PARTS LIST

CABLE				
ITEM #	DESCRIPTION	ID [67] PART NUMBER	MANUFACTURER	
			NAME [7]	PART NUMBER
#2	4 CONDUCTOR	A-97941-014	C&M	

MOTOR CONNECTOR AND ACCESSORIES				
ITEM #	DESCRIPTION	ID PART NUMBER	MANUFACTURER	
			NAME	PART NUMBER
#1	MOTOR PLUG	A-84878	SOURIAU	851-06RX14-5S50-L
#9	CRIMP CONTACTS	A-84879-002	SOURIAU	8500-9331
	CRIMP TOOL	N/A	SOURIAU	MS3191-1
	INSERTION TOOL	N/A	SOURIAU	8500-39
#8	FILLER PLUG	A-84879-001	SOURIAU	8500-4267

AMPLIFIER END				
ITEM #	DESCRIPTION	ID PART NUMBER	MANUFACTURER	
			NAME	PART NUMBER
#4	SPADE LUG	A-84268-002	HOLLINGSWORTH	XSS20836
#3	SPADE LUG	A-84267-002	HOLLINGSWORTH	XSS20B36
	CRIMP TOOL	N/A	HOLLINGSWORTH	#H6E

TUBING & SLEEVING PARTS LIST				
ITEM #	DESCRIPTION	ID PART NUMBER	MANUFACTURER	
			NAME	PART NUMBER
#6	5/8" SHRINK TUB.	H-15577	RAYCHEM	RNF-100-1-5/8"

* THIS CABLE ASSEMBLY TO BE LABELED "GC-M1 or M2A-X/X=XX".

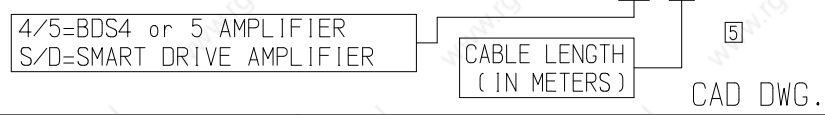

CAD DWG.

ISS.		ECN NO.		DATE		APP' D.		Kollmorgen Industrial Drives RADFORD, VIRGINIA			GOLDLINE AMPLIFIER ASSEMBLY GUIDE FOR MOTOR CABLES (3 THRU 20 AMP)				
K		COPY CODE		ISS.		ECN NO.								DATE	
DWN. BY:		DATE		CHK. BY:		DATE		APP' D. BY:		DATE		SCALE	DWG. NO.	SHEET 3 OF 8	ISSUE
EWR		05-18-92										1:1	A-93421	7	7

(SOLDERED)

GOLDLINE MOTOR CABLE (FOR 10X & 20X EXC. 206D MOTOR)

DWG. NO. **A-93421** SHEET 4 OF 8 ISSUE 7

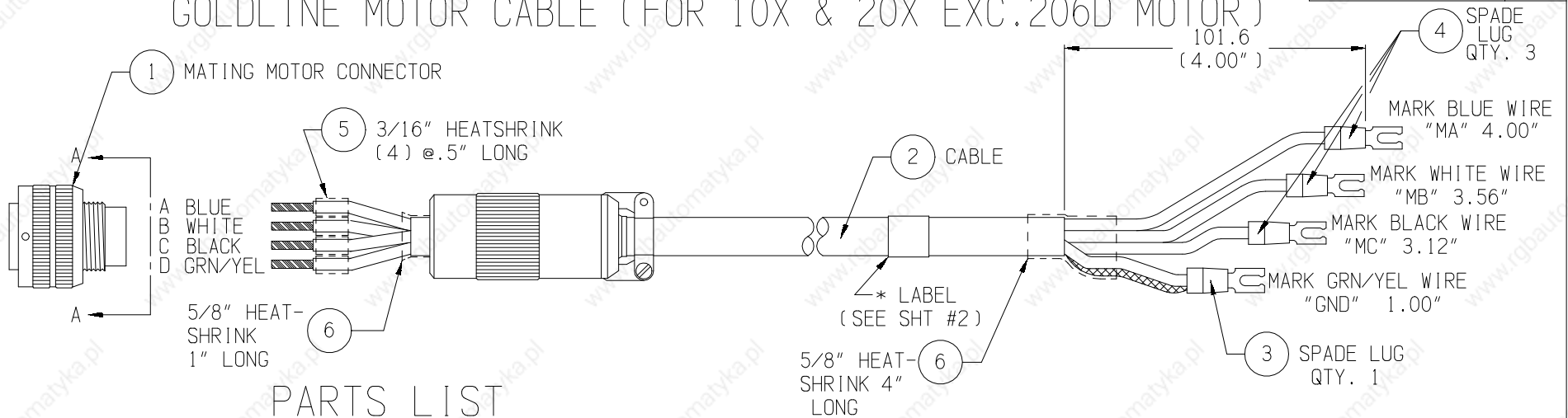

PARTS LIST

CABLE				
ITEM #	DESCRIPTION	ID [67] PART NUMBER	MANUFACTURER	
			NAME [7]	PART NUMBER
#2	4 CONDUCTOR	A-97941-014	C&M	

MOTOR CONNECTOR AND ACCESSORIES				
ITEM #	DESCRIPTION	ID PART NUMBER	MANUFACTURER	
			NAME	PART NUMBER
#1	MOTOR PLUG	A-42867-145	SOURIAU	851-06EC14-5550

AMPLIFIER END				
ITEM #	DESCRIPTION	ID PART NUMBER	MANUFACTURER	
			NAME	PART NUMBER
#4	SPADE LUG	A-84268-002	HOLLINGSWORTH	XSS20836
#3	SPADE LUG	A-84267-002	HOLLINGSWORTH	XSS20B36
	CRIMP TOOL	N/A	HOLLINGSWORTH	#H6E

TUBING & SLEEVING PARTS LIST				
ITEM #	DESCRIPTION	ID PART NUMBER	MANUFACTURER	
			NAME	PART NUMBER
#5	3/16" SHRINK TUB.	G-15265	RAYCHEM	RNF-100-1-3/16"
#6	5/8" SHRINK TUB.	H-15577	RAYCHEM	RNF-100-1-5/8"

* THIS CABLE ASSEMBLY TO BE LABELED "GC-M1 or M2A-X/X-XX"

4/5=BDS4 or 5 AMPLIFIER
S/D=SMART DRIVE AMPLIFIER

CABLE LENGTH
(IN METERS)

CAD DWG.

ISS.	ECN NO.	DATE	APP'D.	ISS.	ECN NO.	DATE	APP'D.

Kollmorgen Industrial Drives
RADFORD, VIRGINIA

GOLDLINE AMPLIFIER ASSEMBLY
GUIDE FOR MOTOR CABLES
(3 THRU 20 AMP)

DWN. BY:	DATE	CHK. BY:	DATE	APP'D. BY:	DATE	SCALE	DWG. NO.	SHEET 4 OF 8	ISSUE
EWR	05-18-92					1:1	A-93421		7

(CRIMPED)
 GOLDLINE MOTOR CABLE (FOR 206D & 40X EXC.406C MOTOR)

DWG. NO. SHEET 5 OF 8 ISSUE
 A-93421 7

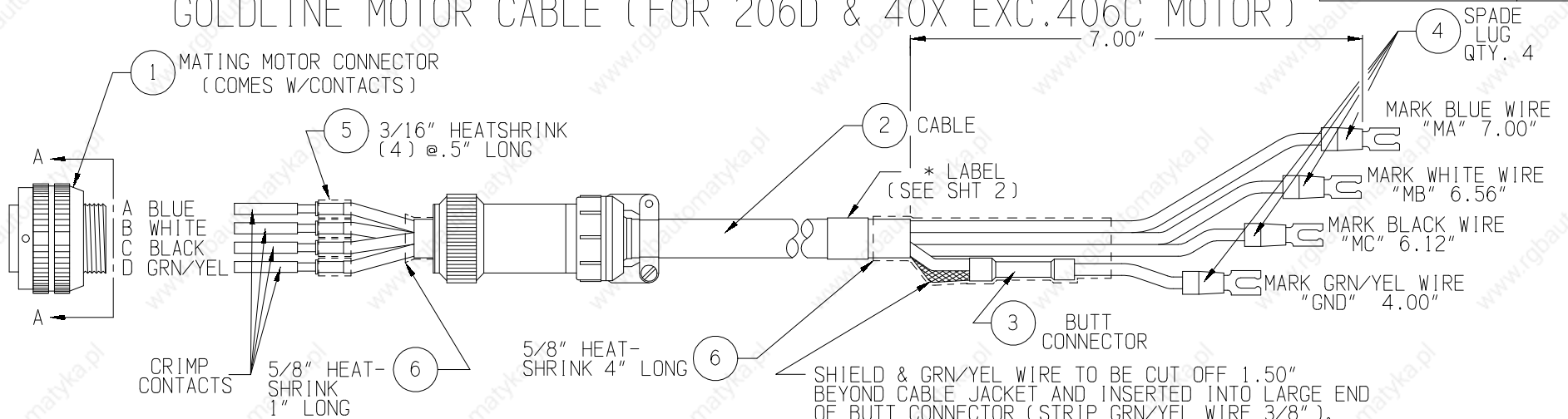

PARTS LIST

CABLE				
ITEM #	DESCRIPTION	ID PART NUMBER	MANUFACTURER	
			NAME	PART NUMBER
#2	4 CONDUCTOR	A-97941-012	C&M	

ITEM #	DESCRIPTION	ID PART NUMBER	MANUFACTURER	
			NAME	PART NUMBER
#4	SPADE LUG	A-84267-002	HOLLINGSWORTH	XSS20836
#3	BUTT CONN.	A-80654-003	HOLLINGSWORTH	B4046BF
	CRIMP TOOL	N/A	HOLLINGSWORTH	#H6E

MOTOR CONNECTOR AND ACCESSORIES				
ITEM #	DESCRIPTION	ID PART NUMBER	MANUFACTURER	
			NAME	PART NUMBER
#1	MOTOR PLUG W/ CRIMP CONTACTS	A-84818	VEAM	CIR. 06LCF-18-10S-F80-38
	GUIDE PINS	N/A	VEAM	27977-12T50
	CRIMP TOOL	N/A	VEAM	AF8
	INSERTION TOOL	N/A	VEAM	46736-6

ITEM #	DESCRIPTION	ID PART NUMBER	MANUFACTURER	
			NAME	PART NUMBER
#5	3/16" SHRINK TUB.	G-15265	RAYCHEM	RNF-100-1-3/16"
#6	5/8" SHRINK TUB.	H-15577	RAYCHEM	RNF-100-1-5/8"

* THIS CABLE ASSEMBLY TO BE LABELED "GC-M28 or M4A-X/X-XX"

4/5=BDS4 or 5 AMPLIFIER
 S/D=SMART DRIVE AMPLIFIER

CABLE LENGTH
 (IN METERS)

CAD DWG.

ISS.	ECN NO.	DATE	APP'D.	ISS.	ECN NO.	DATE	APP'D.

Kollmorgen Industrial Drives
 RADFORD, VIRGINIA

GOLDLINE AMPLIFIER ASSEMBLY
 GUIDE FOR MOTOR CABLES
 (3 THRU 20 AMP)

DWN. BY:	DATE	CHK. BY:	DATE	APP'D. BY:	DATE	SCALE	DWG. NO.	SHEET 5 OF 8	ISSUE
EWR	05-18-92					1:1	A-93421		7

+ (SOLDERED)

GOLDLINE MOTOR CABLE (FOR 206D & 40X EXC. 406C MOTOR)

DWG. NO. SHEET 6 OF 8 ISSUE
A-93421 7

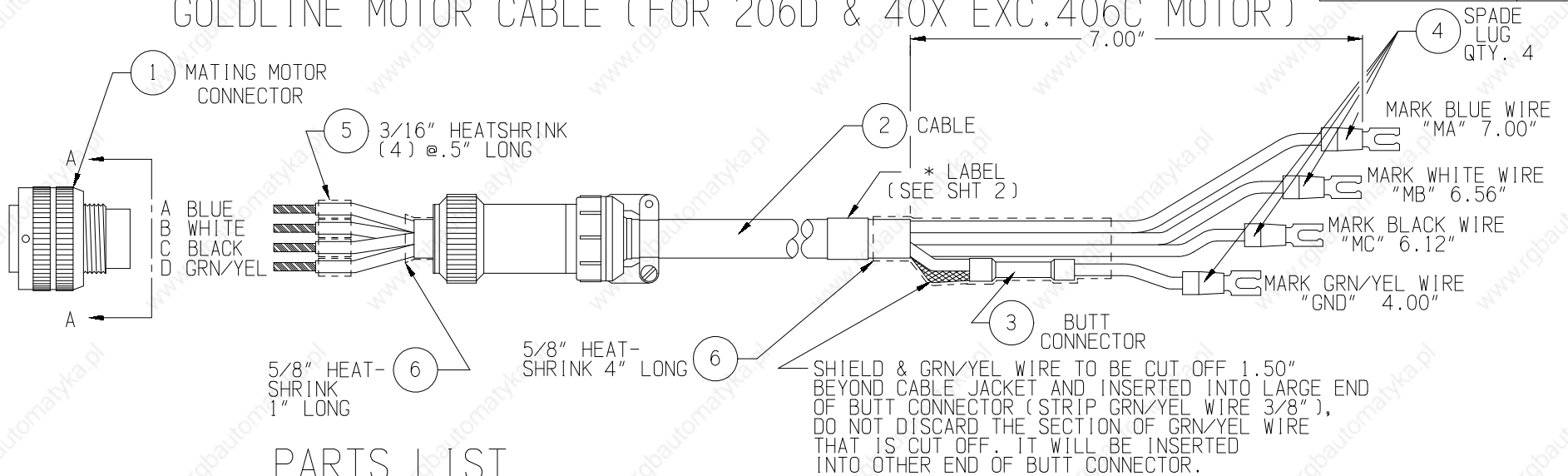

PARTS LIST

CABLE				
ITEM #	DESCRIPTION	ID PART NUMBER	MANUFACTURER	
			NAME	PART NUMBER
#2	4 CONDUCTOR	A-97941-012	C&M	

ITEM #	DESCRIPTION	ID PART NUMBER	MANUFACTURER	
			NAME	PART NUMBER
#4	SPADE LUG	A-84267-002	HOLLINGSWORTH	XSS20836
#3	BUTT CONN.	A-80654-003	HOLLINGSWORTH	B4046BF
	CRIMP TOOL	N/A	HOLLINGSWORTH	#H6E

MOTOR CONNECTOR AND ACCESSORIES				
ITEM #	DESCRIPTION	ID PART NUMBER	MANUFACTURER	
			NAME	PART NUMBER
#1	MOTOR PLUG	A-43173	VEAM	CIR. 06F-18-10S

ITEM #	DESCRIPTION	ID PART NUMBER	MANUFACTURER	
			NAME	PART NUMBER
#5	3/16" SHRINK TUB.	G-15265	RAYCHEM	RNF-100-1-3/16"
#6	5/8" SHRINK TUB.	H-15577	RAYCHEM	RNF-100-1-5/8"

* THIS CABLE ASSEMBLY TO BE LABELED "GC-M28 or M4A-X/X-XX"

4/5=BDS4 or 5 AMPLIFIER
 S/D=SMART DRIVE AMPLIFIER

CABLE LENGTH
 (IN METERS)

CAD DWG.

ISS.	ECN NO.	DATE	APP'D.	ISS.	ECN NO.	DATE	APP'D.	Kollmorgen Industrial Drives RADFORD, VIRGINIA	GOLDLINE AMPLIFIER ASSEMBLY GUIDE FOR MOTOR CABLES (3 THRU 20 AMP)	DWN. BY:	DATE	CHK. BY:	DATE	APP'D. BY:	DATE	SCALE	DWG. NO.	SHEET 6 OF 8	ISSUE
										EWR	05-18-92							1:1	A-93421

+ (CRIMPED)

GOLDLINE MOTOR CABLE (FOR 602A, 602B, 604A & 606A MOTOR)

DWG. NO. SHEET 7 OF 8 ISSUE
A-93421 7

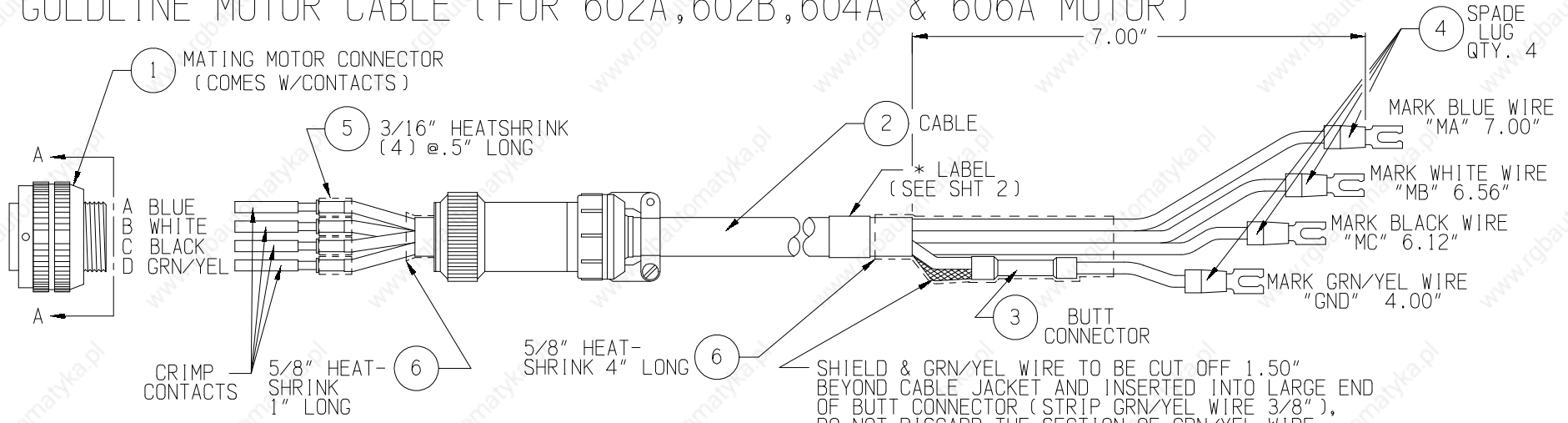

PARTS LIST

CABLE				
ITEM #	DESCRIPTION	ID PART NUMBER	MANUFACTURER	
			NAME	PART NUMBER
#2	4 CONDUCTOR	A-97941-012	C&M	

ITEM #	DESCRIPTION	ID PART NUMBER	MANUFACTURER	
			NAME	PART NUMBER
#4	SPADE LUG	A-84267-002	HOLLINGSWORTH	XSS20836
#3	BUTT CONN.	A-80654-003	HOLLINGSWORTH	B4046BF
	CRIMP TOOL	N/A	HOLLINGSWORTH	#H6E

MOTOR CONNECTOR AND ACCESSORIES				
ITEM #	DESCRIPTION	ID PART NUMBER	MANUFACTURER	
			NAME	PART NUMBER
#1	MOTOR PLUG W/ CRIMP CONTACTS	A-93337	VEAM	CIR. 06SLF-22-22S-F80-26
	GUIDE PINS	N/A	VEAM	27977-12T50
	CRIMP TOOL	N/A	VEAM	AF8
	INSERTION TOOL	N/A	VEAM	46736-6

ITEM #	DESCRIPTION	ID PART NUMBER	MANUFACTURER	
			NAME	PART NUMBER
#5	3/16" SHRINK TUB.	G-15265	RAYCHEM	RNF-100-1-3/16"
#6	5/8" SHRINK TUB.	H-15577	RAYCHEM	RNF-100-1-5/8"

* THIS CABLE ASSEMBLY TO BE LABELED "GC-M6A-X/X-XX".

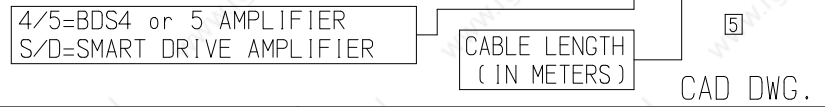

ISS.	ECN NO.	DATE	APP'D.	ISS.	ECN NO.	DATE	APP'D.	<h2>Kollmorgen Industrial Drives</h2> <p>RADFORD, VIRGINIA</p>	GOLDLINE AMPLIFIER ASSEMBLY GUIDE FOR MOTOR CABLES (3 THRU 20 AMP)		
									DWN. BY: EWR DATE: 05-18-92	CHK. BY: DATE:	APP'D. BY: DATE:

(SOLDERED)
GOLDLINE MOTOR CABLE (FOR 602A, 602B, 604A & 606A MOTOR)

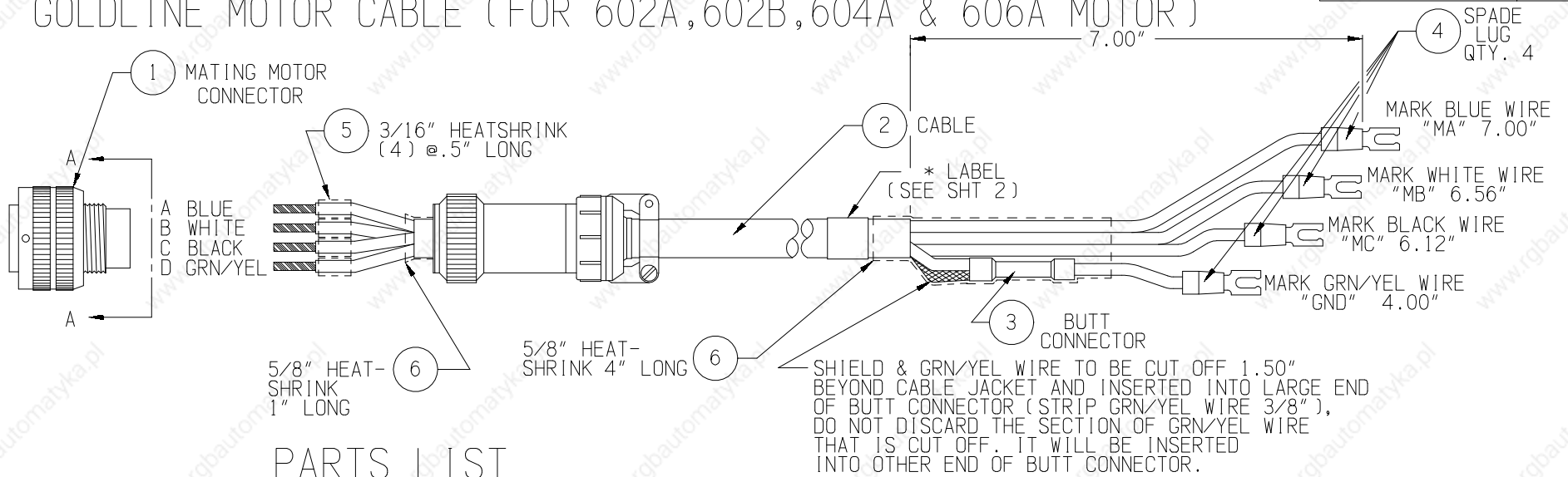

PARTS LIST

CABLE				
ITEM #	DESCRIPTION	ID PART NUMBER	MANUFACTURER	
			NAME	PART NUMBER
#2	4 CONDUCTOR	A-97941-012	C&M	

MOTOR CONNECTOR AND ACCESSORIES				
ITEM #	DESCRIPTION	ID PART NUMBER	MANUFACTURER	
			NAME	PART NUMBER
#1	MOTOR PLUG	A-43642	VEAM	CIR. 06F-22-22S

ITEM #	DESCRIPTION	ID PART NUMBER	MANUFACTURER	
			NAME	PART NUMBER
#4	SPADE LUG	A-84267-002	HOLLINGSWORTH	XSS20836
#3	BUTT CONN.	A-80654-003	HOLLINGSWORTH	B4046BF
	CRIMP TOOL	N/A	HOLLINGSWORTH	#H6E

ITEM #	DESCRIPTION	ID PART NUMBER	MANUFACTURER	
			NAME	PART NUMBER
#5	3/16" SHRINK TUB.	G-15265	RAYCHEM	RNF-100-1-3/16"
#6	5/8" SHRINK TUB.	H-15577	RAYCHEM	RNF-100-1-5/8"

* THIS CABLE ASSEMBLY TO BE LABELED "GC-M6A-X/X-XX".

4/5=BDS4 or 5 AMPLIFIER
 S/D=SMART DRIVE AMPLIFIER

CABLE LENGTH
 (IN METERS)

CAD DWG.

ISS.	ECN NO.	DATE	APP'D.	ISS.	ECN NO.	DATE	APP'D.	Kollmorgen Industrial Drives RADFORD, VIRGINIA	GOLDLINE AMPLIFIER ASSEMBLY GUIDE FOR MOTOR CABLES (3 THRU 20 AMP)		
									DWN. BY: EWR DATE: 05-18-92	CHK. BY: DATE:	APP'D. BY: DATE:

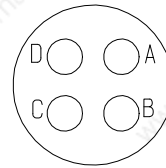
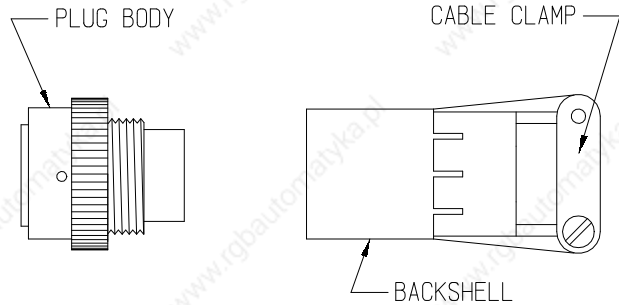

or

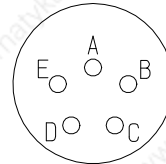

DETAIL A - A

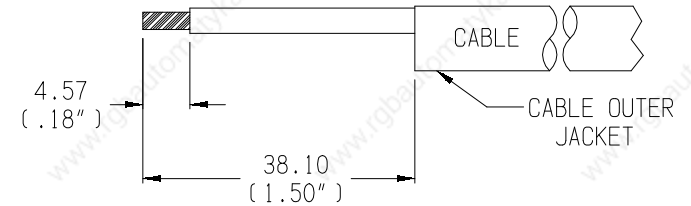

CONNECTOR ASSEMBLY PROCEDURE

- STEP 1 BEFORE ANY OUTER JACKET HAS BEEN REMOVED FROM THE CABLE, SLIDE THE FOLLOWING ITEMS ONTO THE CABLE: 12.7MM (1/2") SHRINK TUBING, BACKSHELL AND 15.88MM (5/8") SHRINK TUBING.
- STEP 2 STRIP THE OUTER CABLE JACKET BACK 38.1MM (1.5"). THIS WILL EXPOSE THE SHIELD AROUND THE INDIVIDUAL WIRES. (THE DIAGRAM ONLY SHOWS ONE WIRE FOR CLARITY)
- STEP 3 A CUT & DISCARD THE SHIELD FROM THIS END OF CABLE.
 B USE STRIPPING PLIERS TO STRIP INSULATION 4.57MM (.18") FROM INDIVIDUAL WIRES.
- STEP 4 A FOR CRIMP CONNECTORS:
 B INSERT WIRES INTO THE CRIMP CONTACTS AND CRIMP.
 C INSERT THE CRIMP CONTACTS INTO THE PLUG BODY, WITH USE OF GUIDE PINS, ACCORDING TO THE CONNECTION CHART.
- STEP 4 A FOR SOLDER CONNECTORS:
 INSERT WIRES INTO THE SOLDER CUPS AND SOLDER.

- STEP 5 A POSITION THE 5/8" HEAT SHRINK TUBING AND APPLY HEAT TO SHRINK TUBING, AS SHOWN ON FOLLOWING SHEETS.
 B SLIDE THE BACKSHELL ALONG THE CABLE TO PLUG BODY.
 C HOLD PLUG BODY SECURELY AND SCREW BACKSHELL ONTO PLUG BODY,
 D TIGHTEN CABLE CLAMP.
 E POSITION THE 1/2" SHRINK TUBING AND APPLY HEAT TO SHRINK TUBING, AS SHOWN ON FOLLOWING SHEETS.
- STEP 6 PLACE LABEL IN APPROXIMATE LOCATION AS SHOWN ON FOLLOWING SHEETS.

NOTE: 1. FOR CABLE ASSEMBLY GCA-M4A-X/X-XX..SEE SHEET #3 OR 4 []
 FOR CABLE ASSEMBLY GCA-M6A-X/X-XX..SEE SHEET #5 OR 6

CAD DWG.

		COPY CODE		ISS.	ECN NO.	DATE	APP'D.	Kollmorgen Industrial Drives RADFORD, VIRGINIA		GOLDLINE AMPLIFIER ASSEMBLY GUIDE FOR MOTOR CABLES (3 THRU 20 AMP)			
ISS.	ECN NO.	DATE	APP'D.							SCALE	DWG. NO.	SHEET 2 OF 6	ISSUE
								1:1	A-93538		7		

(CRIMPED MOTOR CONNECTOR)
 GOLDLINE MOTOR CABLE (FOR 40X EXC.406C MOTOR)

DWG. NO. SHEET 3 OF 6 ISSUE
A-93538 7

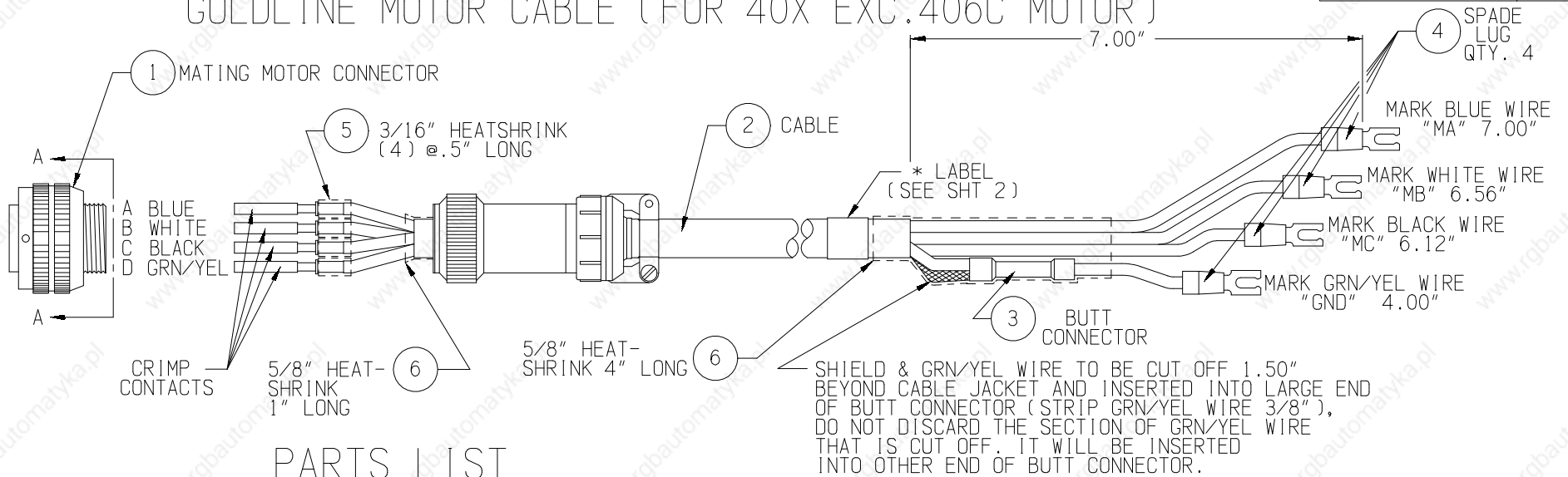

PARTS LIST

CABLE				
ITEM #	DESCRIPTION	ID PART NUMBER	MANUFACTURER	
			NAME	PART NUMBER
#2	4 COND.(12 AWG)	A-97941-012	C&M	

ITEM #	DESCRIPTION	ID PART NUMBER	MANUFACTURER	
			NAME	PART NUMBER
#4	SPADE LUG	A-84267-002	HOLLINGSWORTH	XSS20836
#3	BUTT CONN.	A-80654-003	HOLLINGSWORTH	B4046BF
	CRIMP TOOL	N/A	HOLLINGSWORTH	#H6E

MOTOR CONNECTOR AND ACCESSORIES				
ITEM #	DESCRIPTION	ID PART NUMBER	MANUFACTURER	
			NAME	PART NUMBER
#1	MOTOR PLUG	A-93613-003	POWELL	IN80-214618-10S
	CRIMP CONTACTS	A-93958-003	POWELL	10-329290-183
	CRIMP TOOL	N/A	BENDIX	M22520/1-01

ITEM #	DESCRIPTION	ID PART NUMBER	MANUFACTURER	
			NAME	PART NUMBER
#5	3/16" SHRINK TUB.	G-15265	RAYCHEM	RNF-100-1-3/16"
#6	5/8" SHRINK TUB.	H-15577	RAYCHEM	RNF-100-1-5/8"

* THIS CABLE ASSEMBLY TO BE LABELED "GCA-M4A-X/X-XX".



COPY CODE				ISS.	ECN NO.	DATE	APP'D.	Kollmorgen Industrial Drives RADFORD, VIRGINIA	GOLDLINE AMPLIFIER ASSEMBLY GUIDE FOR MOTOR CABLES (3 THRU 20 AMP)								
ISS.	ECN NO.	DATE	APP'D.						DWN. BY: EWR	DATE 10-07-92	CHK. BY:	DATE	APP'D. BY:	DATE	SCALE 1:1	DWG. NO. A-93538	SHEET 3 OF 6

(SOLDERED MOTOR CONNECTOR)
 GOLDLINE MOTOR CABLE (FOR 40X EXC.406C MOTOR)

DWG. NO. SHEET 4 OF 6 ISSUE
A-93538 7

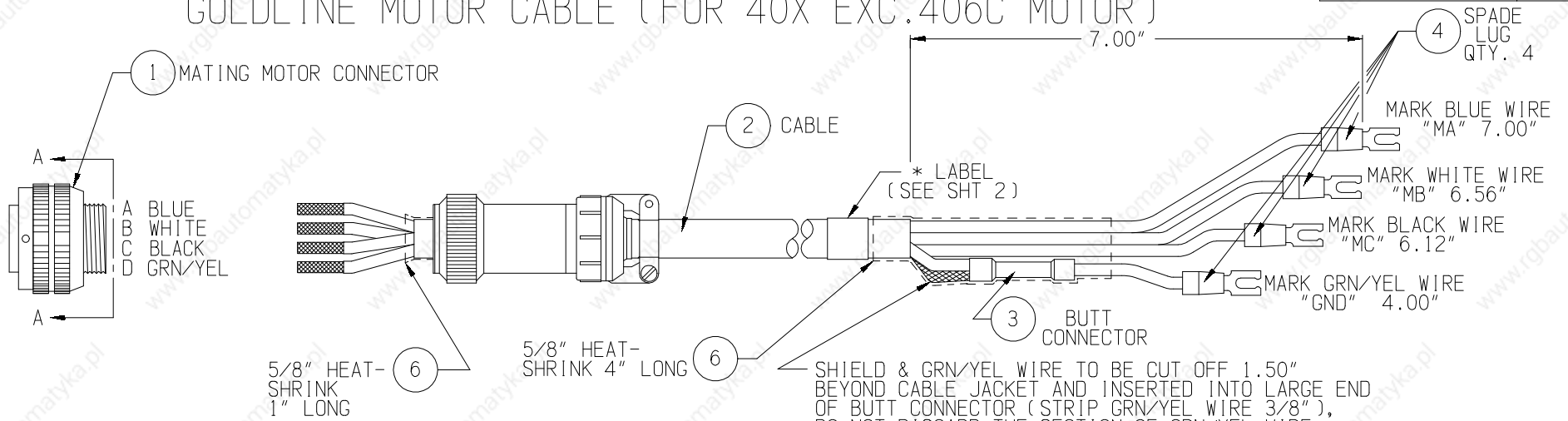

PARTS LIST

CABLE				
ITEM #	DESCRIPTION	ID PART NUMBER	MANUFACTURER	
			NAME	PART NUMBER
#2	4 COND.(12 AWG)	A-97941-012	C&M	

MOTOR CONNECTOR AND ACCESSORIES				
ITEM #	DESCRIPTION	ID PART NUMBER	MANUFACTURER	
			NAME	PART NUMBER
#1	MOTOR PLUG	A-93613-003	BENDIX	MS3106E-18-10S

ITEM #	DESCRIPTION	ID PART NUMBER	MANUFACTURER	
			NAME	PART NUMBER
#4	SPADE LUG	A-84267-002	HOLLINGSWORTH	XSS20836
#3	BUTT CONN.	A-80654-003	HOLLINGSWORTH	B4046BF
	CRIMP TOOL	N/A	HOLLINGSWORTH	#H6E

ITEM #	DESCRIPTION	ID PART NUMBER	MANUFACTURER	
			NAME	PART NUMBER
#6	5/8" SHRINK TUB.	H-15577	RAYCHEM	RNF-100-1-5/8"

* THIS CABLE ASSEMBLY TO BE LABELED "GCA-M4A-X/X-XX".



CAD DWG.

COPY CODE				ISS.	ECN NO.	DATE	APP'D.	Kollmorgen Industrial Drives RADFORD, VIRGINIA	GOLDLINE AMPLIFIER ASSEMBLY GUIDE FOR MOTOR CABLES (3 THRU 20 AMP)								
ISS.	ECN NO.	DATE	APP'D.						DWN. BY: EWR	DATE 10-07-92	CHK. BY:	DATE	APP'D. BY:	DATE	SCALE 1:1	DWG. NO. A-93538	SHEET 4 OF 6

(CRIMPED MOTOR CONNECTOR)
 GOLDLINE MOTOR CABLE (FOR 602A, 602B, 604A & 606A MOTOR)

DWG. NO. SHEET 5 OF 6 ISSUE
A-93538 7

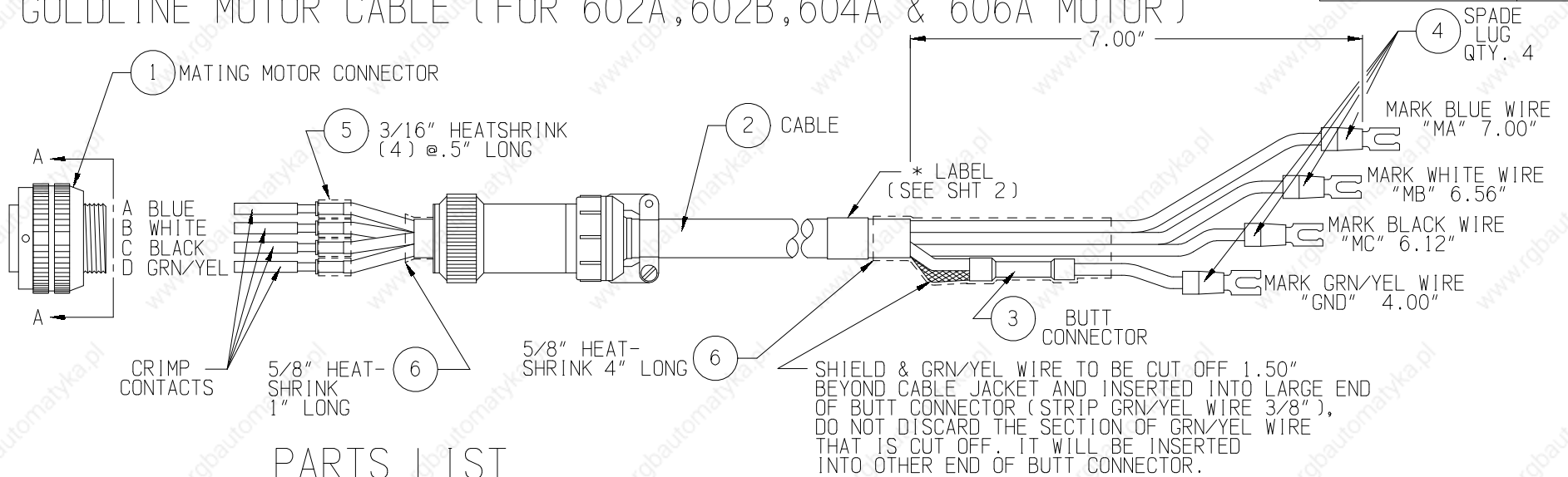

PARTS LIST

CABLE				
ITEM #	DESCRIPTION	ID PART NUMBER	MANUFACTURER	
			NAME	PART NUMBER
#2	4 COND.(12 AWG)	A-97941-012	C&M	

MOTOR CONNECTOR AND ACCESSORIES				
ITEM #	DESCRIPTION	ID PART NUMBER	MANUFACTURER	
			NAME	PART NUMBER
#1	MOTOR PLUG	A-93613-004	POWELL	IN75-69622-22S
	CRIMP CONTACTS	A-93614-004	POWELL	10-40793
	CRIMP TOOL	N/A	BENDIX	M22520/1-01

ITEM #	DESCRIPTION	ID PART NUMBER	MANUFACTURER	
			NAME	PART NUMBER
#4	SPADE LUG	A-84267-002	HOLLINGSWORTH	XSS20836
#3	BUTT CONN.	A-80654-003	HOLLINGSWORTH	B4046BF
	CRIMP TOOL	N/A	HOLLINGSWORTH	#H6E

ITEM #	DESCRIPTION	ID PART NUMBER	MANUFACTURER	
			NAME	PART NUMBER
#5	3/16" SHRINK TUB.	G-15265	RAYCHEM	RNF-100-1-3/16"
#6	5/8" SHRINK TUB.	H-15577	RAYCHEM	RNF-100-1-5/8"

* THIS CABLE ASSEMBLY TO BE LABELED "GCA-M6A-X/X-XX".



CAD DWG.

ISS.				ECN NO.		DATE		APP'D.		Kollmorgen Industrial Drives RADFORD, VIRGINIA			GOLDLINE AMPLIFIER ASSEMBLY GUIDE FOR MOTOR CABLES (3 THRU 20 AMP)		
COPY CODE		ISS.		ECN NO.		DATE		APP'D.							
										1:1	A-93538		7		

(SOLDERED MOTOR CONNECTOR)

GOLDLINE MOTOR CABLE (FOR 602A, 602B, 604A & 606A MOTOR)

DWG. NO. SHEET 6 OF 6 ISSUE
A-93538 7

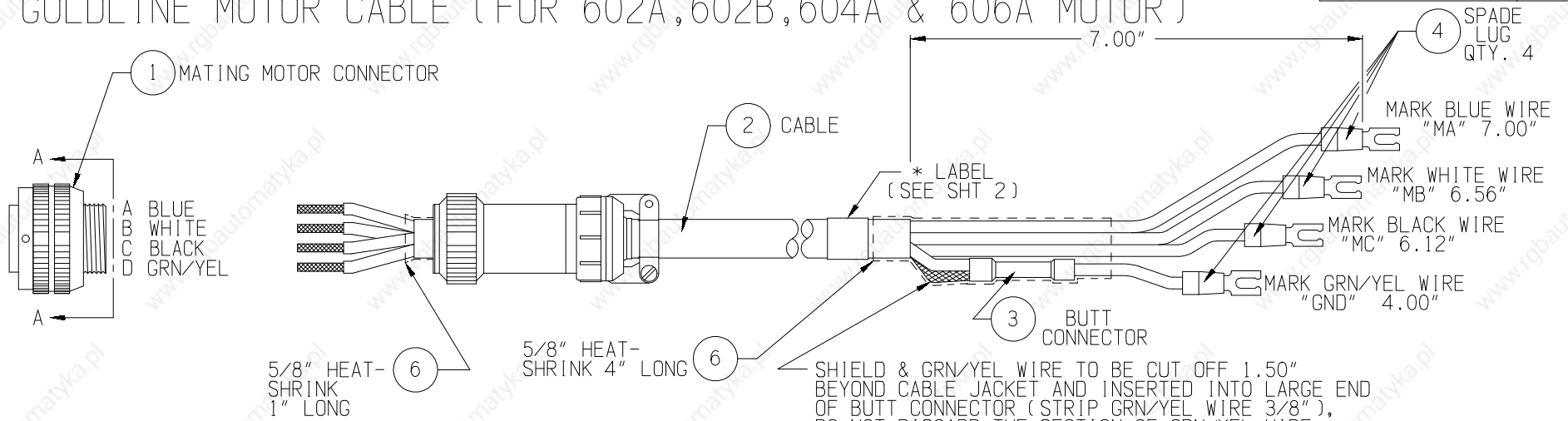

PARTS LIST

CABLE				
ITEM #	DESCRIPTION	ID PART NUMBER	MANUFACTURER	
			NAME	PART NUMBER
#2	4 COND.(12 AWG)	A-97941-012	C&M	

ITEM #	DESCRIPTION	ID PART NUMBER	MANUFACTURER	
			NAME	PART NUMBER
#4	SPADE LUG	A-84267-002	HOLLINGSWORTH	XSS20836
#3	BUTT CONN.	A-80654-003	HOLLINGSWORTH	B4046BF
	CRIMP TOOL	N/A	HOLLINGSWORTH	#H6E

MOTOR CONNECTOR AND ACCESSORIES				
ITEM #	DESCRIPTION	ID PART NUMBER	MANUFACTURER	
			NAME	PART NUMBER
#1	MOTOR PLUG	A-63197	BENDIX	MS3106E-22-22S

ITEM #	DESCRIPTION	ID PART NUMBER	MANUFACTURER	
			NAME	PART NUMBER
#6	5/8" SHRINK TUB.	H-15577	RAYCHEM	RNF-100-1-5/8"

* THIS CABLE ASSEMBLY TO BE LABELED "GCA-M6A-X/X-XX".



CAD DWG.

COPY CODE				ISS.	ECN NO.	DATE	APP'D.	Kollmorgen Industrial Drives RADFORD, VIRGINIA	GOLDLINE AMPLIFIER ASSEMBLY GUIDE FOR MOTOR CABLES (3 THRU 20 AMP)								
ISS.	ECN NO.	DATE	APP'D.						DWN. BY: EWR	DATE 10-07-92	CHK. BY:	DATE	APP'D. BY:	DATE	SCALE 1:1	DWG. NO. A-93538	SHEET 6 OF 6

④

THIS DRAWING CONTAINS THE INFORMATION NECESSARY TO FABRICATE MOTOR CABLES TO BE USED WITH BDS4/5-30, 40, & 55 OR S/D-30 & 55 AMP UNITS WHEN USED ON THE FOLLOWING MOTORS, IF THEY HAVE THREADED CONNECTORS. ⑤

- FOR 406C MOTORS: SEE SHEET 4 & 5
- FOR 604B,604C,606B,606C, & 606D MOTORS: SEE SHEET 5 & 6
- FOR 802A,802B,804A,804B, & 806A MOTORS: SEE SHEET 7 & 8
- FOR 804C & 806B MOTORS: SEE SHEET 9 & 10

④

CAD DWG.

DASH NO.	CABLE LENGTH		DASH NO.	CABLE LENGTH		DASH NO.	CABLE LENGTH	
	METERS	FEET		METERS	FEET		METERS	FEET
-003	3	10	-027	27	90	-051	51	170
-006	6	20	-030	30	100	-054	54	180
-009	9	30	-033	33	110	-057	57	190
-012	12	40	-036	36	120	-060	60	200
-015	15	50	-039	39	130			
-018	18	60	-042	42	140			
-021	21	70	-045	45	150			
-024	24	80	-048	48	160			

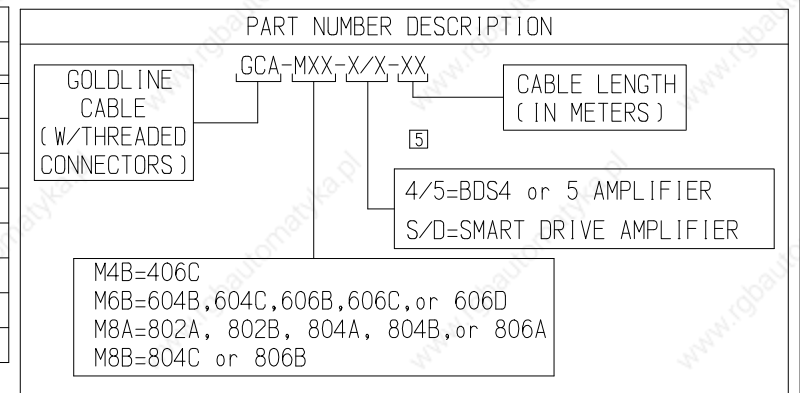

ISS.	U	S	K	COPY CODE	ISS.	ECN NO.	DATE	APP'D.
7				RRH	2	84849 EWR	11-10-92	FDO
8				BKB	3	84942 EWR	01-18-93	FDO
9				MTH	4	85611 TDG	01-26-94	MDBO
10				BKB	5	85963 MAW	07-12-94	SCM
					6	88214 JMM	07-25-96	MDB

Kollmorgen Industrial Drives
RADFORD, VIRGINIA

GOLDLINE ASSEMBLY
 GUIDE FOR MOTOR CABLES

DRAWN BY:	DATE	CHK. BY:	DATE	APP'D. BY:	DATE	SCALE	DWG. NO.	SHEET 1 OF 11	ISSUE
EWR	10-01-92			FDO	11-6-92	1:1	A-93539		14

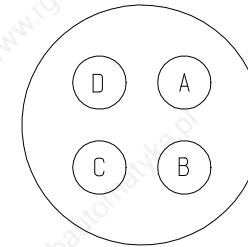
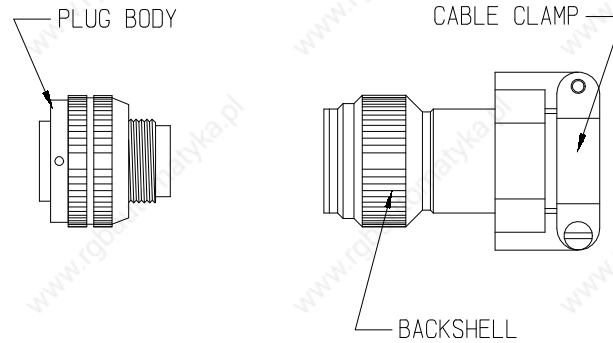

DETAIL A - A

CONNECTOR ASSEMBLY PROCEDURE

STEP 1 USE STRIPPING PLIERS TO STRIP INSULATION 4.57MM (.18") FROM EACH WIRE, BOTH ENDS.

STEP 2 A INSERT WIRES INTO THE CRIMP CONTACTS AND CRIMP. (WHEN CRIMP REDUCTION SLEEVES ARE USED, WIRES ARE TO BE INSERTED IN SLEEVE FIRST!)

B INSERT THE CRIMP CONTACTS INTO THE PLUG BODY, WITH USE OF GUIDE PINS, CONNECT AS SHOWN ON FOLLOWING SHEETS.

STEP 3 A SLIDE THE BACKSHELL ALONG THE WIRES TO PLUG BODY,

B HOLD PLUG BODY SECURELY AND SCREW BACKSHELL ONTO PLUG BODY,

C TIGHTEN CABLE CLAMP.

D PLACE LABEL IN APPROXIMATE LOCATION AS SHOWN ON FOLLOWING SHEETS.

NOTE:

- 1. FOR CABLE ASSEMBLY GCA-M4B-X/X-XX.....SEE SHEET #3 & 4
- FOR CABLE ASSEMBLY GCA-M6B-X/X-XX.....SEE SHEET #5 & 6
- FOR CABLE ASSEMBLY GCA-M8A-X/X-XX.....SEE SHEET #7 & 8
- FOR CABLE ASSEMBLY GCA-M8B-X/X-XX.....SEE SHEET #9

CAD DWG.

		S	K	COPY CODE	ISS.	ECN NO.		DATE	APP'D.	Kollmorgen Industrial Drives RADFORD, VIRGINIA						GOLDLINE ASSEMBLY GUIDE FOR MOTOR CABLES				
ISS.	ECN NO.		DATE	APP'D.	11	302231	RAN	12-98	FDD											
					14	303198	JK	09-99		DRAWN BY:		DATE	CHK. BY:	DATE	APP'D. BY:	DATE	SCALE	DWG. NO.	SHEET 2 OF 11	ISSUE
										EWR	10-01-92						1:1	A-93539		14

(W/CRIMPED CONNECTOR)
GOLDLINE MOTOR CABLE (406C MOTOR)

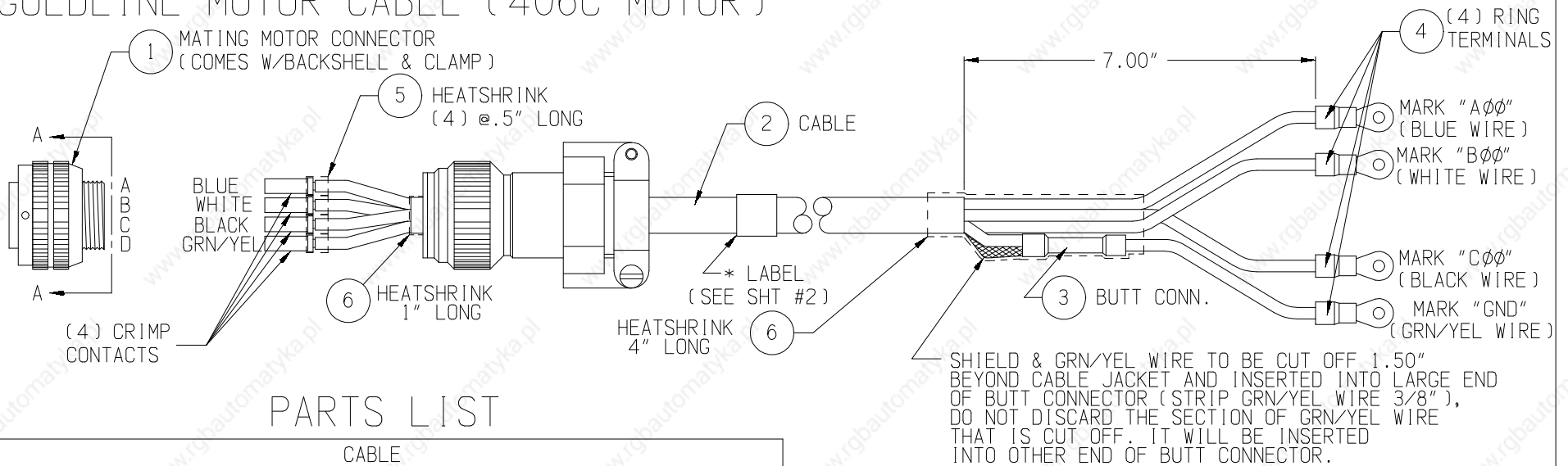

PARTS LIST

CABLE				
ITEM #	DESCRIPTION	ID PART NUMBER	MANUFACTURER	
			NAME	PART NUMBER
#2	4 CONDUCTOR #8 AWG	A-97941-008	C&M	

MOTOR CONNECTOR AND ACCESSORIES				
ITEM #	DESCRIPTION	ID PART NUMBER	MANUFACTURER	
			NAME	PART NUMBER
#1	MOTOR PLUG	A-93613-006	POWELL	1N75-69622-22S
	CRIMP CONTACTS	A-93614-004	POWELL	10-40793
	CRIMP TOOL	N/A	BENDIX	M22520/1-01

ITEM #	DESCRIPTION	ID PART NUMBER	MANUFACTURER	
			NAME	PART NUMBER
#4	RING TERMINAL	A-79406-002	HOLLINGSWORTH	R3027BF
	CRIMP TOOL	N/A	HOLLINGSWORTH	#H6E
#3	BUTT CONN.	A-80654-004	HOLLINGSWORTH	B4047BF
#5	3/16" SHRINK TUB.	G-15265	RAYCHEM	RNF-100-1-3/16"
#6	1" SHRINK TUB.	H-15065	RAYCHEM	RNF-100-1-3/4"

* THIS CABLE ASSEMBLY TO BE LABELED "GCA-M4B-X/X-XX".

- ④ 4/5=BDS4 or 5 AMPLIFIER
- ⑤ S/D=SMART DRIVE AMPLIFIER

CABLE LENGTH
(IN METERS)

ISS.	ECN NO.	DATE	APP'D.	ISS.	ECN NO.	DATE	APP'D.	Kollmorgen Industrial Drives RADFORD, VIRGINIA	GOLDLINE ASSEMBLY GUIDE FOR MOTOR CABLES				
									DWN. BY: EWR DATE: 10-01-92	CHK. BY: DATE:	APP'D. BY: DATE:	SCALE: 1:1	DWG. NO. A-93539

(W/SOLDERED CONNECTOR)
GOLDLINE MOTOR CABLE (406C MOTOR)

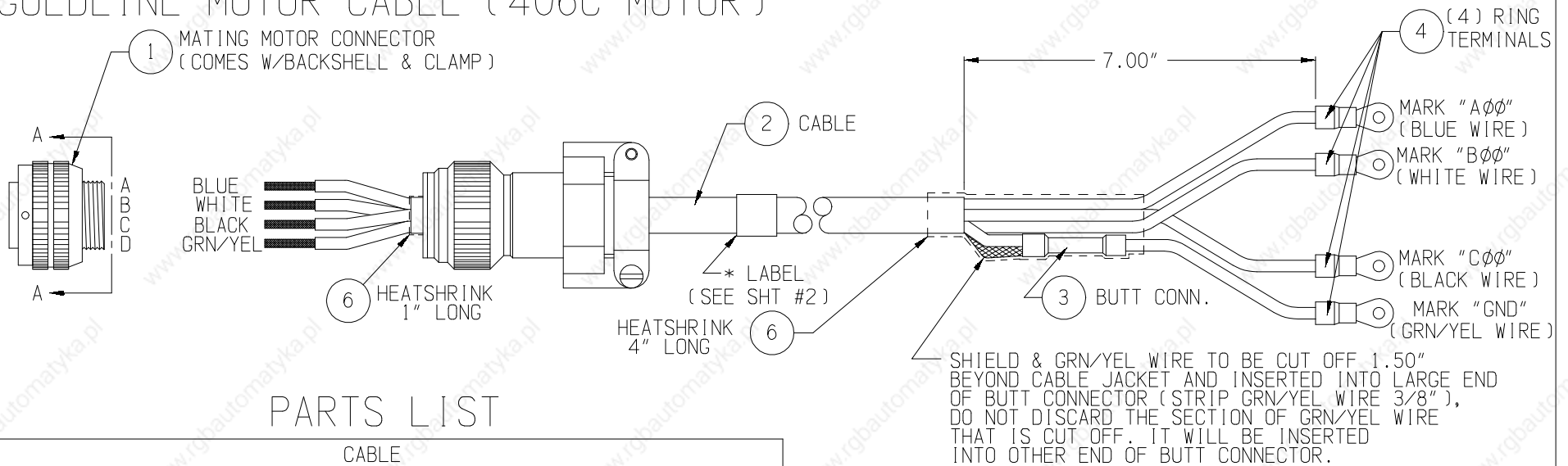

PARTS LIST

CABLE				
ITEM #	DESCRIPTION	ID PART NUMBER	MANUFACTURER	
			NAME	PART NUMBER
#2	4 CONDUCTOR #8 AWG	A-97941-008	C&M	
MOTOR CONNECTOR AND ACCESSORIES				
ITEM #	DESCRIPTION	ID PART NUMBER	MANUFACTURER	
			NAME	PART NUMBER
#1	MOTOR PLUG	A-63197	BENDIX	MS3106E-22-22S

ITEM #	DESCRIPTION	ID PART NUMBER	MANUFACTURER	
			NAME	PART NUMBER
#4	RING TERMINAL	A-79406-002	HOLLINGSWORTH	R3027BF
	CRIMP TOOL	N/A	HOLLINGSWORTH	#H6E
#3	BUTT CONN.	A-80654-004	HOLLINGSWORTH	B4047BF
#6	3/4" SHRINK TUB.	G-17634	RAYCHEM	RNF-100-1-3/4"

* THIS CABLE ASSEMBLY TO BE LABELED "GCA-M4B-X/X-XX".

- [4] 4/5=BDS4 or 5 AMPLIFIER
- [5] S/D=SMART DRIVE AMPLIFIER

CABLE LENGTH
(IN METERS)

ISS.	ECN NO.	DATE	APP'D.	ISS.	ECN NO.	DATE	APP'D.	Kollmorgen Industrial Drives RADFORD, VIRGINIA	GOLDLINE ASSEMBLY GUIDE FOR MOTOR CABLES								
									DWN. BY: EWR	DATE 10-01-92	CHK. BY:	DATE	APP'D. BY:	DATE	SCALE 1:1	DWG. NO. A-93539	SHEET 4 OF 11

(W/CRIMPED CONNECTOR)
GOLDLINE MOTOR CABLE (604B, 604C, 606B, 606C, & 606D MOTOR)

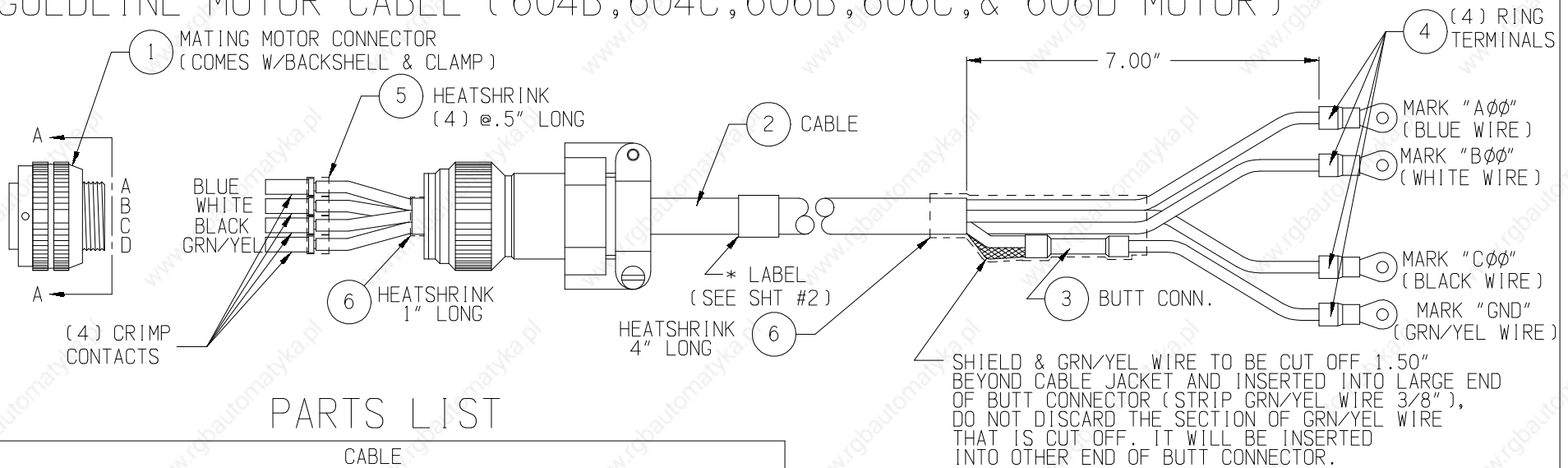

PARTS LIST

CABLE				
ITEM #	DESCRIPTION	ID PART NUMBER	MANUFACTURER	
			NAME	PART NUMBER
#2	4 CONDUCTOR #8 AWG	A-97941-008	C&M	
MOTOR CONNECTOR AND ACCESSORIES				
ITEM #	DESCRIPTION	ID PART NUMBER	MANUFACTURER	
			NAME	PART NUMBER
#1	MOTOR PLUG	A-93613-006	POWELL	1N75-69622-22S
	CRIMP CONTACTS	A-93614-004	POWELL	10-40793
	CRIMP TOOL	N/A	BENDIX	M22520/1-01

ITEM #	DESCRIPTION	ID PART NUMBER	MANUFACTURER	
			NAME	PART NUMBER
#4	RING TERMINAL	A-79406-002	HOLLINGSWORTH	R3027BF
	CRIMP TOOL	N/A	HOLLINGSWORTH	#H6E
#3	BUTT CONN.	A-80654-004	HOLLINGSWORTH	B4047BF
#5	3/16" SHRINK TUB.	G-15265	RAYCHEM	RNF-100-1-3/16"
#6	3/4" SHRINK TUB.	G-17634	RAYCHEM	RNF-100-1-3/4"

* THIS CABLE ASSEMBLY TO BE LABELED "GCA-M6B-X/X-XX".

- [4] 4/5=BDS4 or 5 AMPLIFIER
- [5] S/D=SMART DRIVE AMPLIFIER

CABLE LENGTH
(IN METERS)

ISS.	ECN NO.	DATE	APP'D.	ISS.	ECN NO.	DATE	APP'D.	Kollmorgen Industrial Drives RADFORD, VIRGINIA	GOLDLINE ASSEMBLY GUIDE FOR MOTOR CABLES								
									DWN. BY: EWR	DATE 10-01-92	CHK. BY:	DATE	APP'D. BY:	DATE	SCALE 1:1	DWG. NO. A-93539	SHEET 5 OF 11

(W/SOLDERED CONNECTOR)
GOLDLINE MOTOR CABLE (604B, 604C, 606B, 606C, & 606D MOTOR)

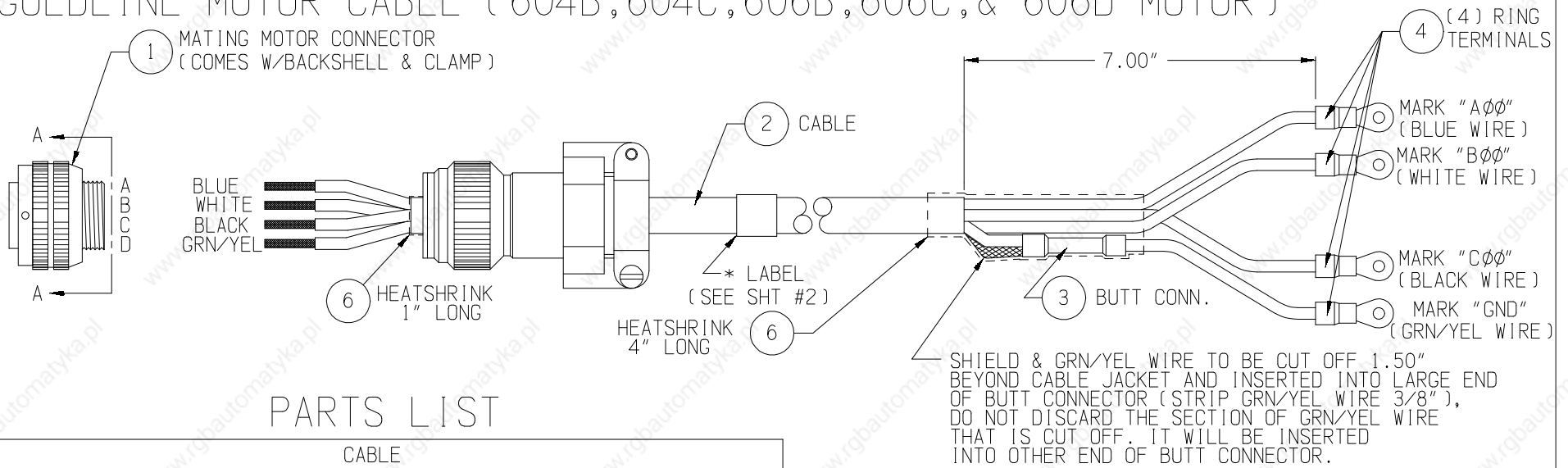

PARTS LIST

CABLE				
ITEM #	DESCRIPTION	ID PART NUMBER	MANUFACTURER	
			NAME	PART NUMBER
#2	4 CONDUCTOR #8 AWG	A-97941-008	C&M	

MOTOR CONNECTOR AND ACCESSORIES				
ITEM #	DESCRIPTION	ID PART NUMBER	MANUFACTURER	
			NAME	PART NUMBER
#1	MOTOR PLUG	A-63197	BENDIX	MS3106E-22-22S

ITEM #	DESCRIPTION	ID PART NUMBER	MANUFACTURER	
			NAME	PART NUMBER
#4	RING TERMINAL	A-79406-002	HOLLINGSWORTH	R3027BF
	CRIMP TOOL	N/A	HOLLINGSWORTH	#H6E
#3	BUTT CONN.	A-80654-004	HOLLINGSWORTH	B4047BF
#6	3/4" SHRINK TUB.	G-17634	RAYCHEM	RNF-100-1-3/4"

* THIS CABLE ASSEMBLY TO BE LABELED "GCA-M6B-X/X-XX".

- ④ 4/5=BDS4 or 5 AMPLIFIER
- ⑤ S/D=SMART DRIVE AMPLIFIER

CABLE LENGTH
(IN METERS)

ISS.	ECN NO.	DATE	APP'D.	ISS.	ECN NO.	DATE	APP'D.	Kollmorgen Industrial Drives RADFORD, VIRGINIA	GOLDLINE ASSEMBLY GUIDE FOR MOTOR CABLES								
									DWN. BY: EWR	DATE 10-01-92	CHK. BY:	DATE	APP'D. BY:	DATE	SCALE 1:1	DWG. NO. A-93539	SHEET 6 OF 11

(W/CRIMPED CONNECTOR)
GOLDLINE MOTOR CABLE (802A, 802B, 804A, 804B, & 806A MOTOR)

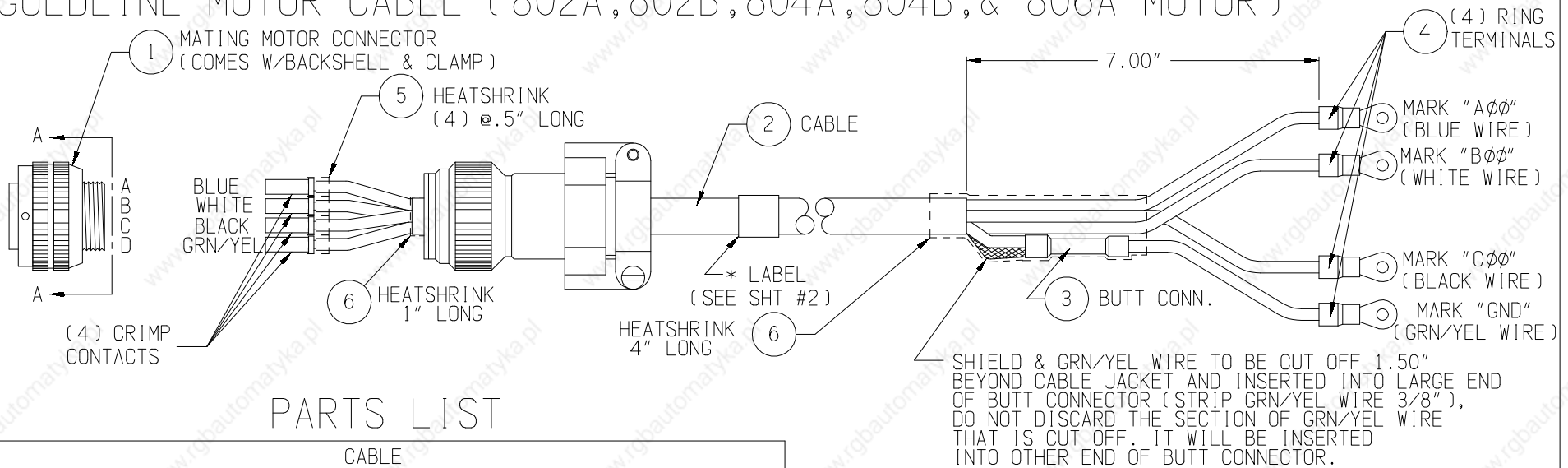

PARTS LIST

CABLE				
ITEM #	DESCRIPTION	ID PART NUMBER	MANUFACTURER	
			NAME	PART NUMBER
#2	4 CONDUCTOR #8 AWG	A-97941-008	C&M	

MOTOR CONNECTOR AND ACCESSORIES				
ITEM #	DESCRIPTION	ID PART NUMBER	MANUFACTURER	
			NAME	PART NUMBER
#1	MOTOR PLUG	A-93613-006	POWELL	1N75-69622-22S
	CRIMP CONTACTS	A-93614-004	POWELL	10-40793
	CRIMP TOOL	N/A	BENDIX	M22520/1-01

ITEM #	DESCRIPTION	ID PART NUMBER	MANUFACTURER	
			NAME	PART NUMBER
#4	RING TERMINAL	A-79406-002	HOLLINGSWORTH	R3027BF
	CRIMP TOOL	N/A	HOLLINGSWORTH	#H6E
#3	BUTT CONN.	A-80654-004	HOLLINGSWORTH	B4047BF
#5	3/16" SHRINK TUB.	G-15265	RAYCHEM	RNF-100-1-3/16"
#6	3/4" SHRINK TUB.	G-17634	RAYCHEM	RNF-100-1-3/4"

* THIS CABLE ASSEMBLY TO BE LABELED "GCA-M8A-X/X-XX".

- ④ 4/5=BDS4 or 5 AMPLIFIER
- ⑤ S/D=SMART DRIVE AMPLIFIER

CABLE LENGTH
(IN METERS)

ISS.	ECN NO.	DATE	APP'D.	ISS.	ECN NO.	DATE	APP'D.	Kollmorgen Industrial Drives RADFORD, VIRGINIA	GOLDLINE ASSEMBLY GUIDE FOR MOTOR CABLES								
									DWN. BY: EWR	DATE 10-01-92	CHK. BY:	DATE	APP'D. BY:	DATE	SCALE 1:1	DWG. NO. A-93539	SHEET 7 OF 11

(W/SOLDERED CONNECTOR)
GOLDLINE MOTOR CABLE (802A, 802B, 804A, 804B, & 806A MOTOR)

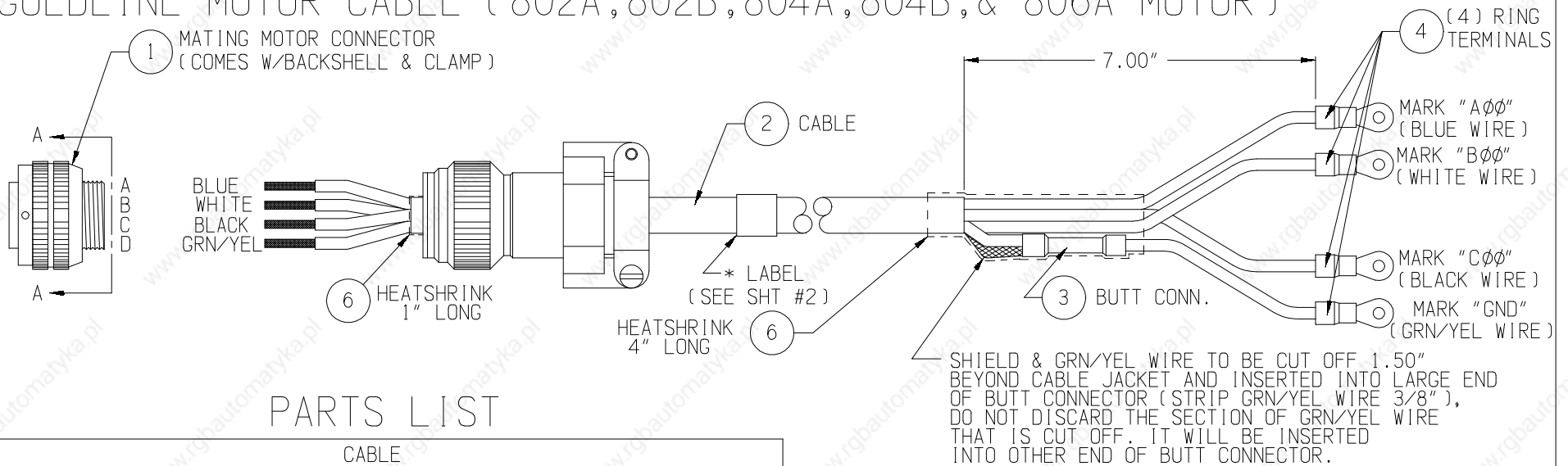

PARTS LIST

CABLE				
ITEM #	DESCRIPTION	ID PART NUMBER	MANUFACTURER	
			NAME	PART NUMBER
#2	4 CONDUCTOR #8	A-97941-008	C&M	

MOTOR CONNECTOR AND ACCESSORIES				
ITEM #	DESCRIPTION	ID PART NUMBER	MANUFACTURER	
			NAME	PART NUMBER
#1	MOTOR PLUG	A-63197	BENDIX	MS3106E-22-22S

ITEM #	DESCRIPTION	ID PART NUMBER	MANUFACTURER	
			NAME	PART NUMBER
#4	RING TERMINAL	A-79406-002	HOLLINGSWORTH	R3027BF
	CRIMP TOOL	N/A	HOLLINGSWORTH	#H6E
#3	BUTT CONN.	A-80654-004	HOLLINGSWORTH	B4047BF
#6	3/4" SHRINK TUB.	G-17634	RAYCHEM	RNF-100-1-3/4"

* THIS CABLE ASSEMBLY TO BE LABELED "GCA-M8A-X/X-XX".

- 4 4/5=BDS4 or 5 AMPLIFIER
- 5 S/D=SMART DRIVE AMPLIFIER

CABLE LENGTH
 (IN METERS)

ISS.	ECN NO.	DATE	APP'D.	ISS.	ECN NO.	DATE	APP'D.	Kollmorgen Industrial Drives RADFORD, VIRGINIA	GOLDLINE ASSEMBLY GUIDE FOR MOTOR CABLES								
									DWN. BY: EWR	DATE 10-01-92	CHK. BY:	DATE	APP'D. BY:	DATE	SCALE 1:1	DWG. NO. A-93539	SHEET 8 OF 11

(W/SOLDERED CONNECTOR)
GOLDLINE MOTOR CABLE (804C & 806B MOTOR)

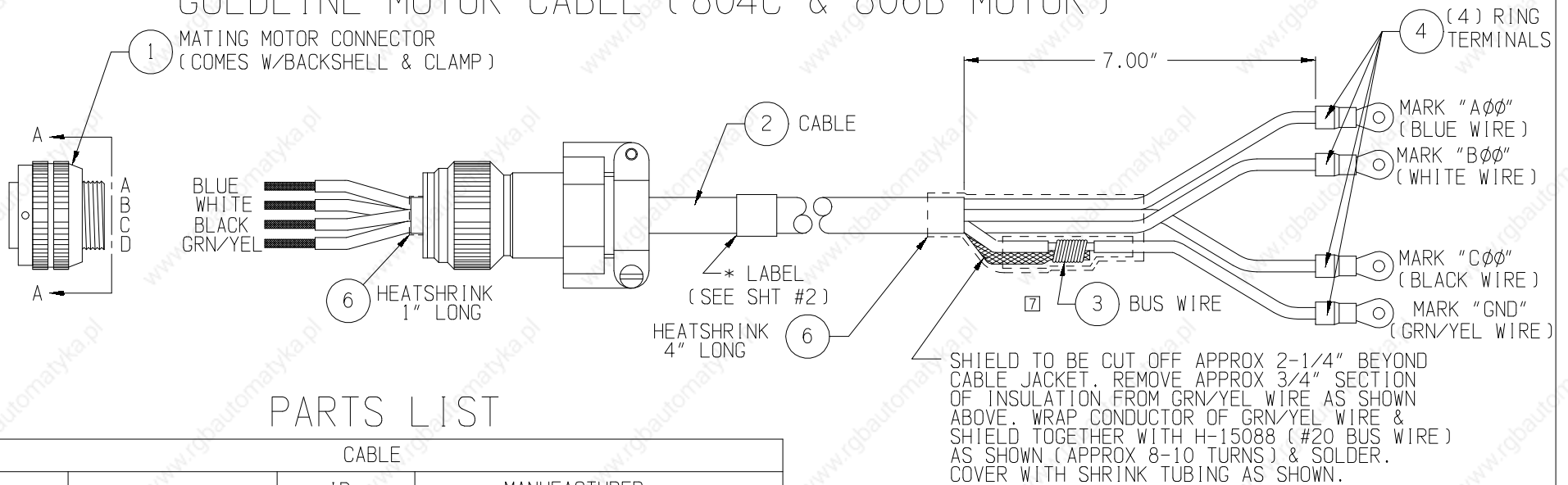

PARTS LIST

CABLE				
ITEM #	DESCRIPTION	ID PART NUMBER	MANUFACTURER	
			NAME	PART NUMBER
#2	4 CONDUCTOR #4	A-97941-004	OMNI	ID0404TBTPR-FLEX
MOTOR CONNECTOR AND ACCESSORIES				
ITEM #	DESCRIPTION	ID PART NUMBER	MANUFACTURER	
			NAME	PART NUMBER
#1	MOTOR PLUG	A-63199	BENDIX	MS3106E-32-17S

ITEM #	DESCRIPTION	ID PART NUMBER	MANUFACTURER	
			NAME	PART NUMBER
#4	RING TERMINAL	P-97793-001	HOLLINGSWORTH	R5128BF
OR	RING TERMINAL	P-97793-001	HOLLINGSWORTH	R5100BF
	CRIMP TOOL	N/A	HOLLINGSWORTH	#H6E
#3	#20 BUS WIRE	H-15088	ALPHA	297
#6	1 1/2" SHRINK TUB.	H-16653	RAYCHEM	RNF-100-1-1 1/2"
#7	5/8" SHRINK TUB.	H-15577	RAYCHEM	RNF-100-1-5/8"

* THIS CABLE ASSEMBLY TO BE LABELED "GCA-M8B-X/X-XX".

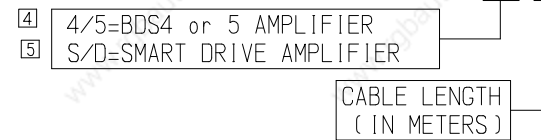

ISS.	ECN NO.	DATE	APP'D.	ISS.	ECN NO.	DATE	APP'D.	Kollmorgen Industrial Drives RADFORD, VIRGINIA	GOLDLINE ASSEMBLY GUIDE FOR MOTOR CABLES						
									DWN. BY: EWR	DATE: 10-01-92	CHK. BY: DATE	APP'D. BY: DATE	SCALE: 1:1	DWG. NO. A-93539	SHEET 9 OF 11

(W/CRIMPED CONNECTOR)
GOLDLINE MOTOR CABLE (804C & 806B MOTOR)

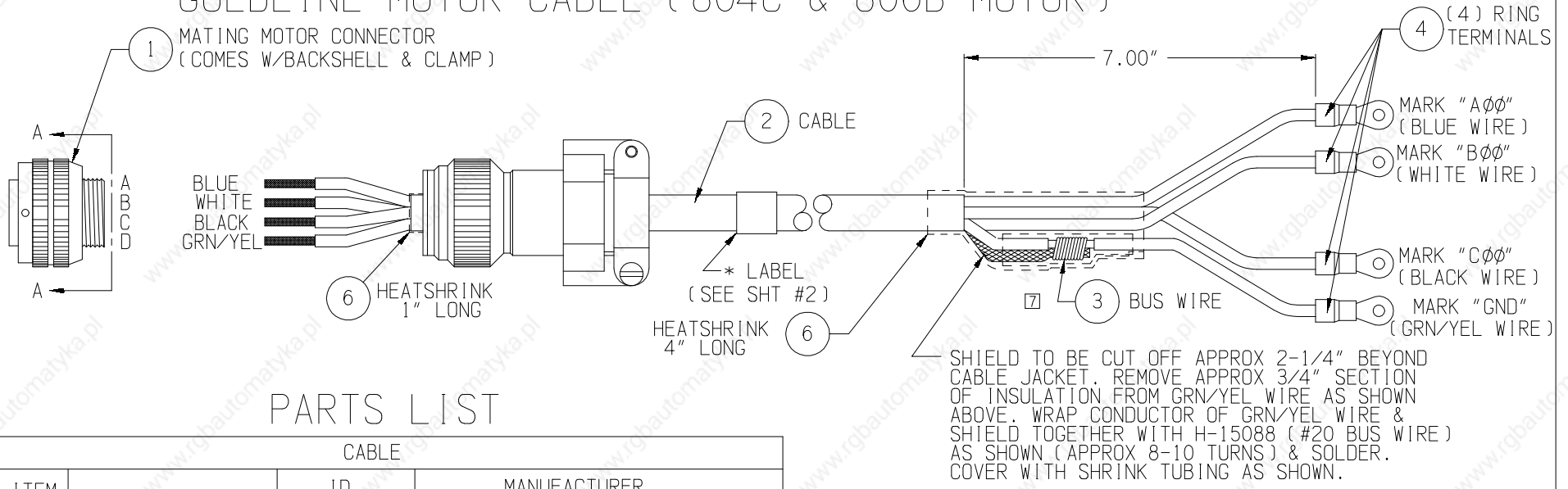

PARTS LIST

CABLE				
ITEM #	DESCRIPTION	ID PART NUMBER	MANUFACTURER	
			NAME	PART NUMBER
#2	4 CONDUCTOR #4	A-97941-004	OMNI	ID0404TBTPR-FLEX

MOTOR CONNECTOR AND ACCESSORIES				
ITEM #	DESCRIPTION	ID PART NUMBER	MANUFACTURER	
			NAME	PART NUMBER
#1	MOTOR PLUG	A-97133	VEAM	VS3016CFZ32-17S-F80-B2

ITEM #	DESCRIPTION	ID PART NUMBER	MANUFACTURER	
			NAME	PART NUMBER
#4	RING TERMINAL	P-97793-001	HOLLINGSWORTH	R5128BF
OR	RING TERMINAL	P-97793-001	HOLLINGSWORTH	R5100BF
	CRIMP TOOL	N/A	HOLLINGSWORTH	#H6E
#3	#20 BUS WIRE [7]	H-15088	ALPHA	297
#6	1 1/2" SHRINK TUB.	H-16653	RAYCHEM	RNF-100-1-1 1/2"
#7	5/8" SHRINK TUB.	H-15577	RAYCHEM	RNF-100-1-5/8"

* THIS CABLE ASSEMBLY TO BE LABELED "GCA-M8B-X/X-XX".

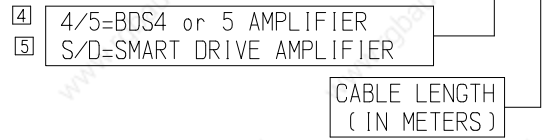

ISS.	ECN NO.	DATE	APP'D.	ISS.	ECN NO.	DATE	APP'D.	Kollmorgen Industrial Drives RADFORD, VIRGINIA	GOLDLINE ASSEMBLY GUIDE FOR MOTOR CABLES								
									DWN. BY: EWR	DATE: 10-01-92	CHK. BY:	DATE:	APP'D. BY:	DATE:	SCALE: 1:1	DWG. NO. A-93539	SHEET 10 OF 11

(W/CRIMPED CONNECTOR)
 THREADED MOTOR CABLE (85A)

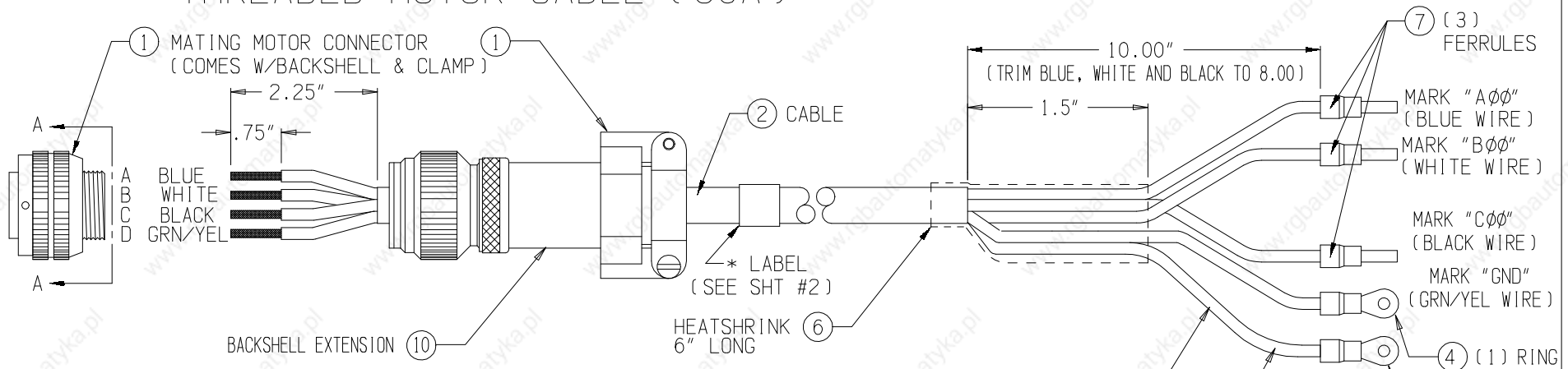

PARTS LIST

CABLE				
ITEM #	DESCRIPTION	ID PART NUMBER	MANUFACTURER	
			NAME	PART NUMBER
#2	4 CONDUCTOR #2	A-97941-002	C + M	

MOTOR CONNECTOR AND ACCESSORIES				
ITEM #	DESCRIPTION	ID PART NUMBER	MANUFACTURER	
			NAME	PART NUMBER
#1	MOTOR PLUG	A-97943	BENDIX	75-068636-5S
#10	EXTENSION	P-98036-001	GLENAIR	320BS002B27-3N

SHIELD TO BE TWISTED INTO SINGLE CONDUCTOR, COVERED WITH YELLOW/GREEN SLEEVING AND TERMINATED WITH RING TERMINAL (P-98025-001).
 HEAT SHRINK TUBING

ITEM #	DESCRIPTION	ID PART NUMBER	MANUFACTURER	
			NAME	PART NUMBER
#4	RING TERMINAL	P-97917-001	HOLLINGSWORTH	R7998BFN
	CRIMP TOOL	N/A	HOLLINGSWORTH	
#3	BUS WIRE	H-15088		
#6	1 1/2" SHRINK TUB.	H-16653	RAYCHEM	RNF-100-1-1 1/2"
#7	FERRULE	A-82570-024	WEIDMULLER	
#8	1/2" SHRINK TUBE	P-98025-001	HOLLINGSWORTH	
#9	RING TERMINAL	A-79407-001	RAYCHEM	DCPT-12/6-45

*THIS CABLE TO BE LABELED "A-93539-3XX" AND ISSUE LENGTH IN METERS—

		K	COPY CODE	ISS.	ECN NO.	DATE	APP' D.	Kollmorgen Industrial Drives RADFORD, VIRGINIA				GOLDLINE ASSEMBLY GUIDE FOR MOTOR CABLES					
ISS.	ECN NO.	DATE	APP' D.														
								DWN. BY:	DATE	CHK. BY:	DATE	APP'D. BY:	DATE	SCALE	DWG. NO.	SHEET 11 OF 11	ISSUE
								EWR	10-01-92					1:1	A-93539		14

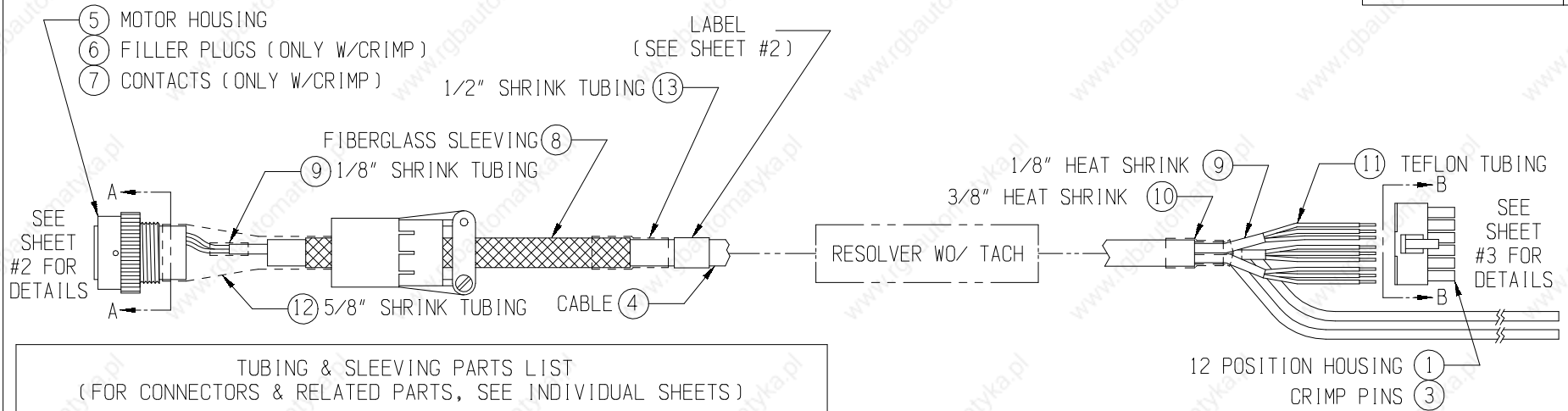

TUBING & SLEEVING PARTS LIST
 (FOR CONNECTORS & RELATED PARTS, SEE INDIVIDUAL SHEETS)

ITEM #	DESCRIPTION	ID PART NUMBER	MANUFACTURER	
			NAME	PART NUMBER
#8	FBRGLASS SLEEVING	A-84824-025	MARKEL	H455BA1000
#9	1/8" SHRINK TUB.	G-15266	RAYCHEM	RNF-100-1-1/8"
#10	3/8" SHRINK TUB.	H-15063	RAYCHEM	RNF-100-1-3/8"
#11	TEFLON TUB.	H-15079	RAYCHEM	TFL16
#12	5/8" SHRINK TUB.	H-15577	RAYCHEM	RNF-100-1-5/8"
#13	1/2" SHRINK TUB.	H-15699	RAYCHEM	RNF-100-1-1/2"

DASH NO.	CABLE LENGTH		DASH NO.	CABLE LENGTH		DASH NO.	CABLE LENGTH	
	METERS	FEET		METERS	FEET		METERS	FEET
-003	3	10	-027	27	90	-051	51	170
-006	6	20	-030	30	100	-054	54	180
-009	9	30	-033	33	110	-057	57	190
-012	12	40	-036	36	120	-060	60	200
-015	15	50	-039	39	130			
-018	18	60	-042	42	140			
-021	21	70	-045	45	150			
-024	24	80	-048	48	160			

PART NUMBER DESCRIPTION

GOLDLINE CABLE: GCA-RXX-X/X-XX

CABLE LENGTH (IN METERS)

4/5=BDS4 AMPLIFIER

R =THERMOSTAT/RESOLVER
 RT =THERMOSTAT/RESOLVER/TACH
 RB =THERMOSTAT/RESOLVER/BRAKE
 RBT =THERMOSTAT/RESOLVER/BRAKE/TACH

ISS.		ECN NO.		DATE		APP'D.		Kollmorgen Industrial Drives RADFORD, VIRGINIA				GOLDLINE AMPLIFIER ASSEMBLY GUIDE FOR RESOLVER CABLES											
K		COPY CODE		ISS.		ECN NO.										DATE		APP'D.					
ISS.		ECN NO.		DATE		APP'D.		2		85531 LLS		12-16-93		CJF		SCALE		DWG. NO.		SHEET 1 OF 13		ISSUE	
								3		85963 MAW		07-12-94		SCM		1:1		A-93540				5	
								4		86027 AWL		08-10-94		SCM		DWN. BY:		DATE		CHK. BY:		DATE	
								5		86346 MAW		12-20-94		EWR		10-07-92		FDO		10-13-92		OWENS	

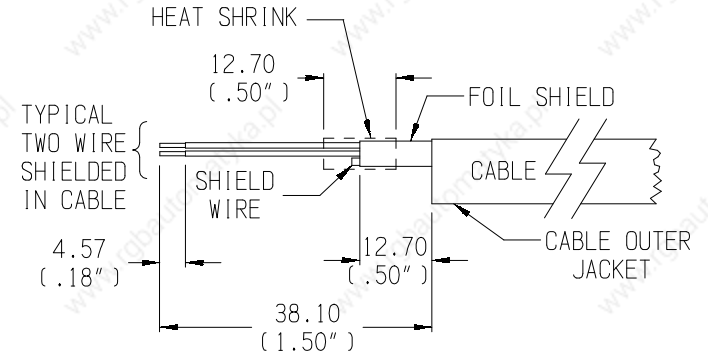
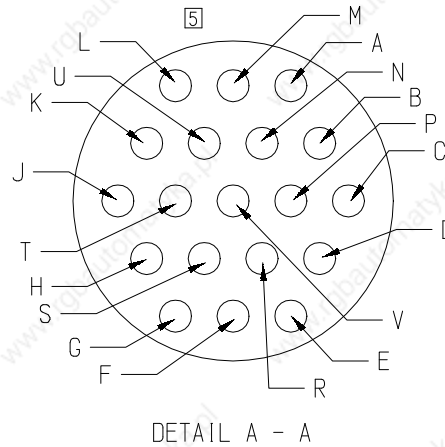
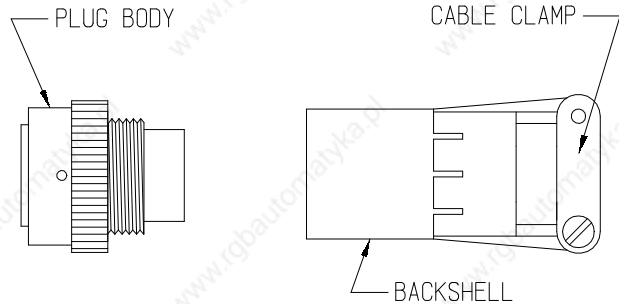

CONNECTOR ASSEMBLY PROCEDURE

- STEP 1 BEFORE ANY OUTER JACKET HAS BEEN REMOVED FROM THE CABLE, SLIDE THE FOLLOWING ITEMS ONTO THE CABLE: 12.7MM (1/2") SHRINK TUBING, FIBERGLASS SLEEVING, BACKSHELL AND 15.88 (5/8) SHRINK TUBING.
- STEP 2 STRIP THE OUTER CABLE JACKET BACK 38.1MM (1.5"). THIS WILL EXPOSE THE INDIVIDUAL FOIL SHIELDED WIRES. (THE DIAGRAM ONLY SHOWS ONE SHIELDED PAIR FOR CLARITY)
- STEP 3 A REMOVE THE FOIL SHIELD FROM THE WIRE.
 B CUT THE SHIELD WIRE FLUSH WITH THE FOIL SHIELD.
 C PLACE HEATSHRINK OVER THE END OF THE FOIL SHIELD AND SHIELD WIRE TO KEEP THE SHIELDS FROM TOUCHING.
 D USE STRIPPING PLIERS TO STRIP INSULATION 4.57MM (.18") FROM INDIVIDUAL WIRES.
- STEP 4 A FOR CRIMP CONNECTORS:
 B INSERT FILLER PLUGS IN:M,L,K,J,H,G & V UNTIL THEY ARE FLUSH WITH THE PLUG.
 C INSERT WIRES INTO THE CRIMP CONTACTS AND CRIMP. INSERT THE CRIMP CONTACTS INTO THE PLUG BODY, WITH USE OF GUIDE PINS, ACCORDING TO THE CONNECTION CHART.

- STEP 4 A FOR SOLDER CONTACTS:
 INSERT THE WIRES INTO THE SOLDER CUPS AND SOLDER.
- STEP 5 A POSITION THE 5/8" HEAT SHRINK TUBING AND FIBERGLASS SLEEVING AS PICTURED ON SHEET #1. APPLY HEAT TO SHRINK TUBING.
 B SLIDE THE BACKSHELL ALONG THE CABLE TO PLUG BODY.
 C HOLD PLUG BODY SECURE AND SCREW BACKSHELL ONTO PLUG BODY.
 D TIGHTEN CABLE CLAMP.
 E POSITION THE 1/2" SHRINK TUBING AS PICTURED ON SHEET #1. APPLY HEAT TO SHRINK TUBING.
- STEP 6 PLACE LABEL IN APPROXIMATE LOCATION AS SHOWN ON SHEET #1. REFER TO NOTE BELOW CONNECTION CHART, SAME AS USED IN STEP 4 A, FOR CORRECT LABEL MARKING.

NOTE: 1. FOR CABLE ASSEMBLY GCA-R-X/X-XXSEE SHEET #6 OR 7

3

		K	COPY CODE	ISS.	ECN NO.	DATE	APP'D.	Kollmorgen Industrial Drives RADFORD, VIRGINIA		GOLDLINE AMPLIFIER ASSEMBLY GUIDE FOR RESOLVER CABLES							
ISS.	ECN NO.	DATE	APP'D.														
								DNW. BY:	DATE	CHK. BY:	DATE	APP'D. BY:	DATE	SCALE	DWG. NO.	SHEET 2 OF 13	ISSUE
								EWR	10-07-92					1:1	A-93540		5

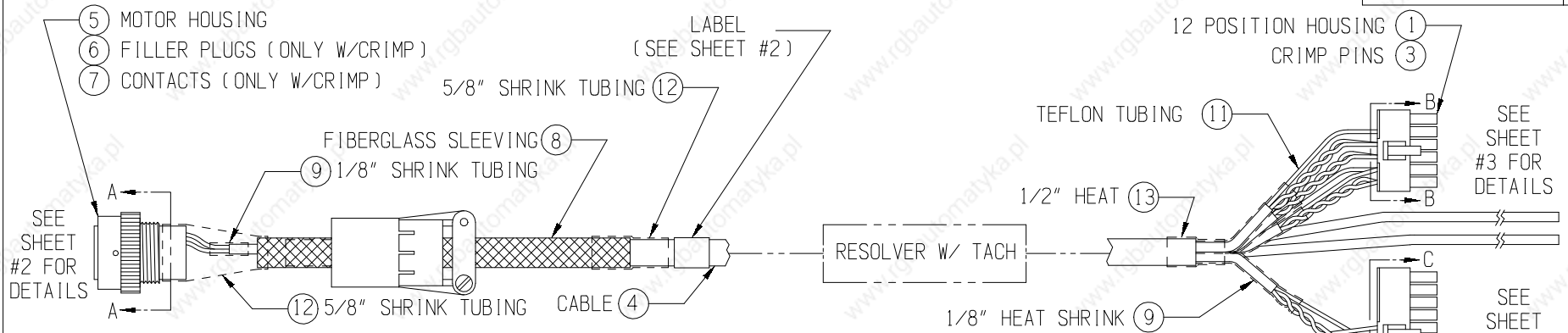

TUBING & SLEEVING PARTS LIST
 (FOR CONNECTORS & RELATED PARTS, SEE INDIVIDUAL SHEETS)

ITEM #	DESCRIPTION	ID PART NUMBER	MANUFACTURER	
			NAME	PART NUMBER
#8	FBRGLASS SLEEVING	A-84824-026	MARKEL	H457BA1000
#9	1/8" SHRINK TUB.	G-15266	RAYCHEM	RNF-100-1-1/8"
#11	TEFLON TUB.	H-15079	RAYCHEM	TFL16
#12	5/8" SHRINK TUB.	H-15577	RAYCHEM	RNF-100-1-5/8"
#13	1/2" SHRINK TUB.	H-15699	RAYCHEM	RNF-100-1-1/2"

DASH NO.	CABLE LENGTH		DASH NO.	CABLE LENGTH		DASH NO.	CABLE LENGTH	
	METERS	FEET		METERS	FEET		METERS	FEET
-003	3	10	-027	27	90	-051	51	170
-006	6	20	-030	30	100	-054	54	180
-009	9	30	-033	33	110	-057	57	190
-012	12	40	-036	36	120	-060	60	200
-015	15	50	-039	39	130			
-018	18	60	-042	42	140			
-021	21	70	-045	45	150			
-024	24	80	-048	48	160			

PART NUMBER DESCRIPTION

GOLDLINE CABLE: **GCA-RXX-X/X-XX** CABLE LENGTH (IN METERS)

4/5=BDS4 AMPLIFIER

R = THERMOSTAT/RESOLVER
 RT = THERMOSTAT/RESOLVER/TACH
 RB = THERMOSTAT/RESOLVER/BRAKE
 RBT = THERMOSTAT/RESOLVER/BRAKE/TACH

③ ④

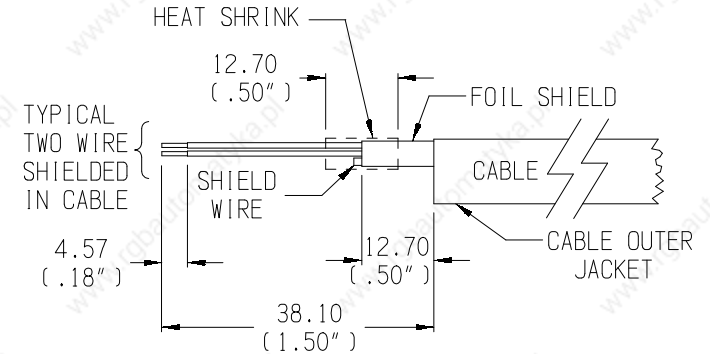
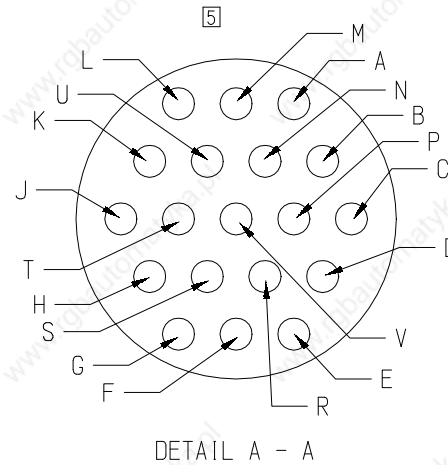
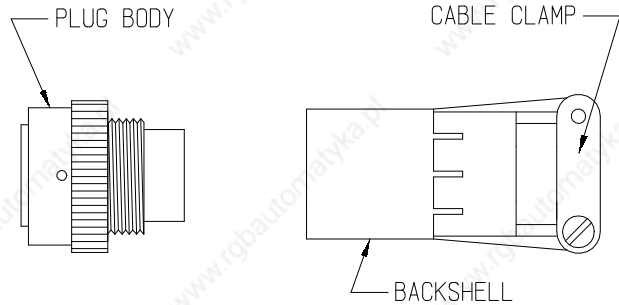

CONNECTOR ASSEMBLY PROCEDURE

- STEP 1 BEFORE ANY OUTER JACKET HAS BEEN REMOVED FROM THE CABLE, SLIDE THE FOLLOWING ITEMS ONTO THE CABLE: 15.8 (5/8") X 25.4 (1.00") LONG SHRINK TUBING, FIBERGLASS SLEEVING, BACKSHELL AND 15.88 (5/8) X 31.7 (1.25") SHRINK TUBING.
- STEP 2 STRIP THE OUTER CABLE JACKET BACK 38.1MM (1.5"). THIS WILL EXPOSE THE INDIVIDUAL FOIL SHIELDED WIRES. (THE DIAGRAM ONLY SHOWS ONE SHIELDED PAIR FOR CLARITY)
- STEP 3 A REMOVE THE FOIL SHIELD FROM THE WIRE.
 B CUT THE SHIELD WIRE FLUSH WITH THE FOIL SHIELD.
 C PLACE HEATSHRINK OVER THE END OF THE FOIL SHIELD AND SHIELD WIRE TO KEEP THE SHIELDS FROM TOUCHING.
 D USE STRIPPING PLIERS TO STRIP INSULATION 4.57MM (.18") FROM INDIVIDUAL WIRES.
- STEP 4 A FOR CRIMP CONNECTORS:
 B INSERT FILLER PLUGS IN: M, L, K, J, H, G & V UNTIL THEY ARE FLUSH WITH THE PLUG.
 C INSERT WIRES INTO THE CRIMP CONTACTS AND CRIMP. INSERT THE CRIMP CONTACTS INTO THE PLUG BODY, WITH USE OF GUIDE PINS, ACCORDING TO THE CONNECTION CHART.

- STEP 4 A FOR SOLDER CONTACTS:
 INSERT THE WIRES INTO THE SOLDER CUPS AND SOLDER.
- STEP 5 A POSITION THE 5/8" X 1.25" HEAT SHRINK TUBING AND FIBERGLASS SLEEVING AS PICTURED ON SHEET #1. APPLY HEAT TO SHRINK TUBING.
 B SLIDE THE BACKSHELL ALONG THE CABLE TO PLUG BODY.
 C HOLD PLUG BODY SECURE AND SCREW BACKSHELL ONTO PLUG BODY.
 D TIGHTEN CABLE CLAMP.
 E POSITION THE 5/8" X 1.00" SHRINK TUBING AS PICTURED ON SHEET #1. APPLY HEAT TO SHRINK TUBING.
- STEP 6 PLACE LABEL IN APPROXIMATE LOCATION AS SHOWN ON SHEET #1. REFER TO NOTE BELOW CONNECTION CHART, SAME AS USED IN STEP 4 A, FOR CORRECT LABEL MARKING.

NOTE: 1. FOR CABLE ASSEMBLY GCA-RB-X/X-XXSEE SHEET #8 OR 9
 FOR CABLE ASSEMBLY GCA-RT-X/X-XXSEE SHEET #10 OR 11
 FOR CABLE ASSEMBLY GCA-RBT-X/X-XX ...SEE SHEET #12 OR 13

3

		K	COPY CODE	ISS.	ECN NO.	DATE	APP'D.	Kollmorgen Industrial Drives RADFORD, VIRGINIA		GOLDLINE AMPLIFIER ASSEMBLY GUIDE FOR RESOLVER CABLES							
ISS.	ECN NO.	DATE	APP'D.														
								DNW. BY:	DATE	CHK. BY:	DATE	APP'D. BY:	DATE	SCALE	DWG. NO.	SHEET 4 OF 13	ISSUE
								EWR	10-07-92					1:1	A-93540		5

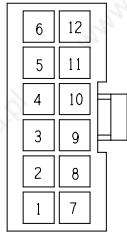

DETAIL B - B

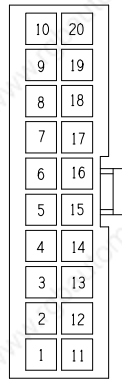

DETAIL C - C

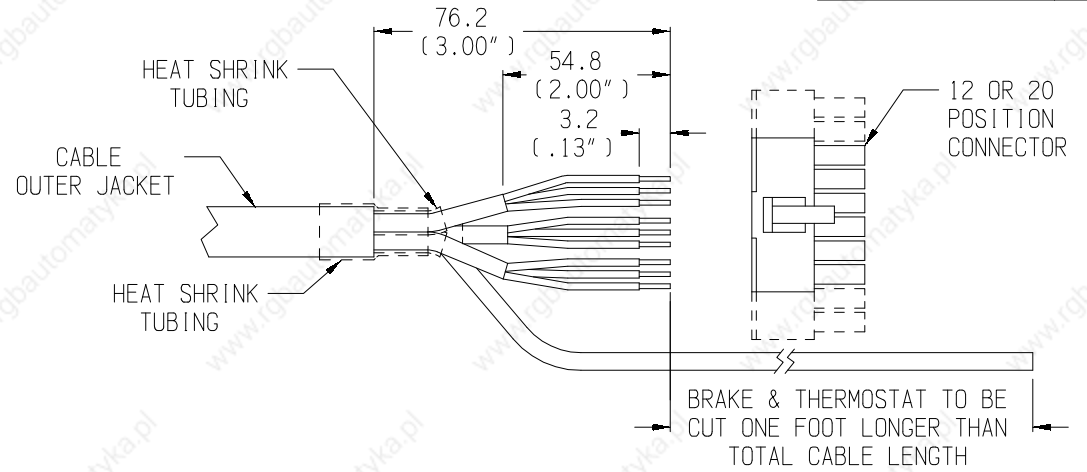

CONNECTOR ASSEMBLY PROCEDURE

- STEP 1 BEFORE ANY OUTER JACKET HAS BEEN REMOVED FROM THE CABLE, SLIDE A SECTION OF HEAT SHRINK TUBING ONTO THE CABLE.
- STEP 2 STRIP THE CABLE OUTER JACKET BACK, 381MM (15.00"). THIS WILL EXPOSE THE INDIVIDUAL FOIL SHIELDS.
- STEP 3 ACCORDING TO THE CONNECTION CHART, SELECT ONE OF THE WIRE PAIRS AND COMPLETE THE FOLLOWING OPERATIONS. SEE NOTE #1.
 - A REMOVE THE FOIL SHIELD FROM THE WIRE.
 - B COVER SHIELD WIRE WITH TUBING.
 - C COVER THE THREE LEADS WITH HEAT SHRINK.
 - D USE STRIPPING PLIERS TO STRIP INSULATION FROM INDIVIDUAL WIRES, 3.2MM (.13").
 - E CRIMP PINS TO EACH OF THE THREE WIRES.
 - F INSERT WIRES INTO 12 OR 20 POSITION CONNECTOR.

- STEP 4 PERFORM STEP 3 FOR EACH REMAINING PAIRS.
- STEP 5 SLIDE THE HEATSHRINK TUBING, FROM STEP #1, ONTO THE END OF THE CABLE AND SHRINK, AS SHOWN ABOVE.

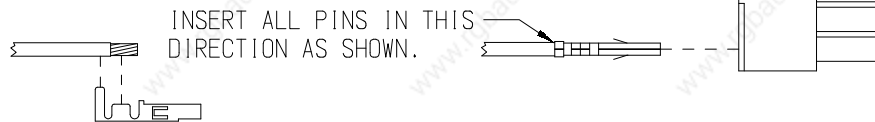

		K	COPY CODE	ISS.	ECN NO.	DATE	APP'D.	Kollmorgen Industrial Drives RADFORD, VIRGINIA		GOLDLINE AMPLIFIER ASSEMBLY GUIDE FOR RESOLVER CABLES							
ISS.	ECN NO.	DATE	APP'D.														
								DWN. BY: EWR	DATE 10-07-92	CHK. BY:	DATE	APP'D. BY:	DATE	SCALE 1:1	DWG. NO. A-93540	SHEET 5 OF 13	ISSUE 5

(W/CRIMPED MOTOR CONNECTOR)
 GOLDLINE RESOLVER CABLE WITH THERMOSTAT (GCA-R-X/X-XX)

DWG. NO. SHEET 6 OF 13 | ISSUE
A-93540 | 5

PARTS LIST

CABLE				
ITEM #	DESCRIPTION	ID PART NUMBER	MANUFACTURER	
			NAME	PART NUMBER
#4	4 PAIR	A-81948	BELDEN	8725

MOTOR CONNECTOR AND ACCESSORIES				
ITEM #	DESCRIPTION	ID PART NUMBER	MANUFACTURER	
			NAME	PART NUMBER
#5	MOTOR HOUSING	A-93613-001	POWELL	IN75-69622-14S
#7	CRIMP CONTACT	A-93614-001	POWELL	10-40556
#6	FILLER PLUG	A-93615-001	POWELL	10-405996-16
#7	REDUCER	A-93616-001	POWELL	10-74696-16
	CRIMP TOOL	N/A	BENDIX	M22520/1-01

BDS4 C2 OR BDS5 C3 AND ACCESSORIES				
ITEM #	DESCRIPTION	ID PART NUMBER	MANUFACTURER	
			NAME	PART NUMBER
#1	12 POS. HOUSING	A-83908-012	MOLEX	39-01-2125
#3	CRIMP PIN	A-83909-002	MOLEX	39-00-0039
	CRIMP TOOL	N/A	MOLEX	HTR-60622

CONNECTION CHART

MOTOR CONNECTION ITEM #5	* CABLE ITEM #4	BDS4 C2 or BDS5 C3 ITEM #1	BDS4 C1 ITEM #2
TERMINAL A	RED	TERMINAL 7	N/C
TERMINAL B	BLACK	TERMINAL 1	
N/C	SHIELD	TERMINAL 8	
TERMINAL C	WHT/YEL	TERMINAL 3	
TERMINAL D	WHT/GRN	TERMINAL 9	
N/C	SHIELD	TERMINAL 2	
TERMINAL E	WHT/RED	TERMINAL 10	
TERMINAL F	WHT/BLK	TERMINAL 4	
N/C	SHIELD	TERMINAL 5	
TERMINAL N			
TERMINAL P		N/C	
TERMINAL R			
TERMINAL S		N/C	
TERMINAL T	GREEN	CUSTOMER	
TERMINAL U	WHITE	THERMOSTAT	
N/C	SHIELD	HOOK-UP	

SEE SHEET 2 AND 3 FOR CONNECTOR DETAILS.
 * THIS CABLE ASSEMBLY TO BE LABELED "GCA-R-X/X-XX".

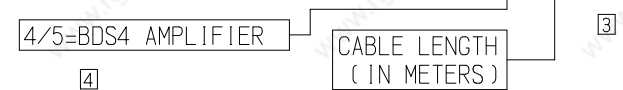

ISS.		ECN NO.		DATE		APP'D.		Kollmorgen Industrial Drives RADFORD, VIRGINIA		GOLDLINE AMPLIFIER ASSEMBLY GUIDE FOR RESOLVER CABLES									
K		COPY CODE		ISS.		ECN NO.				DATE		SCALE		DWG. NO. SHEET 6 OF 13		ISSUE			
+										1:1		A-93540		5					
								DWN. BY: EWR		DATE: 10-07-92		CHK. BY:		DATE:		APP'D. BY:		DATE:	

(W/SOLDERED MOTOR CONNECTOR)
 GOLDLINE RESOLVER CABLE WITH THERMOSTAT (GCA-R-X/X-XX)

DWG. NO. SHEET 7 OF 13 | ISSUE
A-93540 | 5

PARTS LIST

CABLE				
ITEM #	DESCRIPTION	ID PART NUMBER	MANUFACTURER	
			NAME	PART NUMBER
#4	4 PAIR	A-81948	BELDEN	8725

MOTOR CONNECTOR AND ACCESSORIES				
ITEM #	DESCRIPTION	ID PART NUMBER	MANUFACTURER	
			NAME	PART NUMBER
#5	MOTOR HOUSING	G-10158	BENDIX	MS3106E-22-14S

BDS4 C2 OR BDS5 C3 AND ACCESSORIES				
ITEM #	DESCRIPTION	ID PART NUMBER	MANUFACTURER	
			NAME	PART NUMBER
#1	12 POS. HOUSING	A-83908-012	MOLEX	39-01-2125
#3	CRIMP PIN	A-83909-002	MOLEX	39-00-0039
	CRIMP TOOL	N/A	MOLEX	HTR-60622

CONNECTION CHART

MOTOR CONNECTION ITEM #5	* CABLE ITEM #4	BDS4 C2 or BDS5 C3 ITEM #1	BDS4 C1 ITEM #2
TERMINAL A	RED	TERMINAL 7	N/C
TERMINAL B	BLACK	TERMINAL 1	
N/C	SHIELD	TERMINAL 8	
TERMINAL C	WHT/YEL	TERMINAL 3	
TERMINAL D	WHT/GRN	TERMINAL 9	
N/C	SHIELD	TERMINAL 2	
TERMINAL E	WHT/RED	TERMINAL 10	
TERMINAL F	WHT/BLK	TERMINAL 4	
N/C	SHIELD	TERMINAL 5	
TERMINAL N			
TERMINAL P		N/C	
TERMINAL R			
TERMINAL S		N/C	
TERMINAL T	GREEN	CUSTOMER	
TERMINAL U	WHITE	THERMOSTAT	
N/C	SHIELD	HOOK-UP	

SEE SHEET 2 AND 3 FOR CONNECTOR DETAILS.
 * THIS CABLE ASSEMBLY TO BE LABELED "GCA-R-X/X-XX".

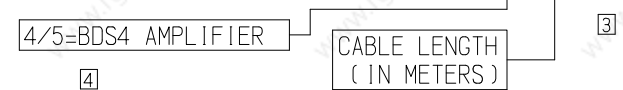

ISS.	ECN NO.	DATE	APP'D.	ISS.	ECN NO.	DATE	APP'D.	Kollmorgen Industrial Drives RADFORD, VIRGINIA	GOLDLINE AMPLIFIER ASSEMBLY GUIDE FOR RESOLVER CABLES				
									DWN. BY: EWR DATE: 10-07-92	CHK. BY: DATE:	APP'D. BY: DATE:	SCALE: 1:1	DWG. NO. A-93540 SHEET 7 OF 13

(W/CRIMPED MOTOR CONNECTOR)
 GOLDLINE RESOLVER CABLE WITH THERMOSTAT AND BRAKE (GCA-RB-X/X-XX)

PARTS LIST

CABLE				
ITEM #	DESCRIPTION	ID PART NUMBER	MANUFACTURER	
			NAME	PART NUMBER
#4	6 PAIR	A-96027-004	CAROL	S0573

MOTOR CONNECTOR AND ACCESSORIES				
ITEM #	DESCRIPTION	ID PART NUMBER	MANUFACTURER	
			NAME	PART NUMBER
#5	MOTOR HOUSING	A-93613-001	POWELL	IN75-69622-14S
#7	CRIMP CONTACT	A-93614-001	POWELL	10-40556
#6	FILLER PLUG	A-93615-001	POWELL	10-405996-16
#7	REDUCER	A-93616-001	POWELL	10-74696-16
	CRIMP TOOL	N/A	BENDIX	M22520/1-01

BDS4 C2 OR BDS5 C3 AND ACCESSORIES				
ITEM #	DESCRIPTION	ID PART NUMBER	MANUFACTURER	
			NAME	PART NUMBER
#1	12 POS. HOUSING	A-83908-012	MOLEX	39-01-2125
#3	CRIMP PIN	A-83909-002	MOLEX	39-00-0039
	CRIMP TOOL	N/A	MOLEX	HTR-60622

NOTE:
 1. RESOLVER END: CUT-OFF REMAINING PAIR 12.7MM (1/2") FROM CABLE JACKET AND FOLD BACK OVER JACKET, PLACE UNDER HEAT SHRINK.
 MOTOR END: CUT-OFF REMAINING PAIR EVEN WITH CABLE JACKET.

CONNECTION CHART

MOTOR CONNECTION ITEM #5	* CABLE ITEM #4	BDS4 C2 or BDS5 C3 ITEM #1	BDS4 C1 ITEM #2
TERMINAL A	RED 1	TERMINAL 7	N/C
TERMINAL B	BLK 1	TERMINAL 1	
N/C	SHIELD	TERMINAL 8	
TERMINAL C	RED 2	TERMINAL 3	
TERMINAL D	BLK 2	TERMINAL 9	
N/C	SHIELD	TERMINAL 2	
TERMINAL E	RED 3	TERMINAL 10	
TERMINAL F	BLK 3	TERMINAL 4	
N/C	SHIELD	TERMINAL 5	
TERMINAL N	RED 4	CUSTOMER BRAKE	
TERMINAL P	BLK 4	HOOK-UP	
N/C	SHIELD		
TERMINAL R	SEE NOTE #1	N/C	
TERMINAL S			
TERMINAL T	RED 6	CUSTOMER THERMOSTAT	
TERMINAL U	BLK 6	HOOK-UP	
N/C	SHIELD		

SEE SHEET 2 AND 3 FOR CONNECTOR DETAILS.
 * THIS CABLE ASSEMBLY TO BE LABELED "GCA-RB-X/X-XX".

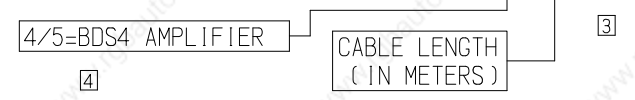

Kollmorgen Industrial Drives
 RADFORD, VIRGINIA

GOLDLINE AMPLIFIER ASSEMBLY
 GUIDE FOR RESOLVER CABLES

DWN. BY: EWR	DATE 10-07-92	CHK. BY:	DATE	APP'D. BY:	DATE	SCALE 1:1	DWG. NO. A-93540	SHEET 8 OF 13	ISSUE 5
-----------------	------------------	----------	------	------------	------	--------------	---------------------	---------------	------------

ISS.	ECN NO.	DATE	APP'D.	ISS.	ECN NO.	DATE	APP'D.

(W/SOLDERED MOTOR CONNECTOR)
 GOLDLINE RESOLVER CABLE WITH THERMOSTAT AND BRAKE (GCA-RB-X/X-XX)

PARTS LIST

CABLE				
ITEM #	DESCRIPTION	ID PART NUMBER	MANUFACTURER	
			NAME	PART NUMBER
#4	6 PAIR	A-96027-004	CAROL	S0573

MOTOR CONNECTOR AND ACCESSORIES				
ITEM #	DESCRIPTION	ID PART NUMBER	MANUFACTURER	
			NAME	PART NUMBER
#5	MOTOR HOUSING	G-10158	BENDIX	MS3106E-22-14S

BDS4 C2 OR BDS5 C3 AND ACCESSORIES				
ITEM #	DESCRIPTION	ID PART NUMBER	MANUFACTURER	
			NAME	PART NUMBER
#1	12 POS. HOUSING	A-83908-012	MOLEX	39-01-2125
#3	CRIMP PIN	A-83909-002	MOLEX	39-00-0039
	CRIMP TOOL	N/A	MOLEX	HTR-60622

NOTE:

- RESOLVER END: CUT-OFF REMAINING PAIR 12.7MM (1/2") FROM CABLE JACKET AND FOLD BACK OVER JACKET, PLACE UNDER HEAT SHRINK.
 MOTOR END: CUT-OFF REMAINING PAIR EVEN WITH CABLE JACKET.

CONNECTION CHART

MOTOR CONNECTION ITEM #5	* CABLE ITEM #4	BDS4 C2 or BDS5 C3 ITEM #1	BDS4 C1 ITEM #2
TERMINAL A	RED 1	TERMINAL 7	N/C
TERMINAL B	BLK 1	TERMINAL 1	
N/C	SHIELD	TERMINAL 8	
TERMINAL C	RED 2	TERMINAL 3	
TERMINAL D	BLK 2	TERMINAL 9	
N/C	SHIELD	TERMINAL 2	
TERMINAL E	RED 3	TERMINAL 10	
TERMINAL F	BLK 3	TERMINAL 4	
N/C	SHIELD	TERMINAL 5	
TERMINAL N	RED 4	CUSTOMER	
TERMINAL P	BLK 4	BRAKE	
N/C	SHIELD	HOOK-UP	
TERMINAL R	SEE NOTE #1		
TERMINAL S		N/C	
TERMINAL T	RED 6	CUSTOMER	
TERMINAL U	BLK 6	THERMOSTAT	
N/C	SHIELD	HOOK-UP	

SEE SHEET 2 AND 3 FOR CONNECTOR DETAILS.
 * THIS CABLE ASSEMBLY TO BE LABELED "GCA-RB-X/X-XX".

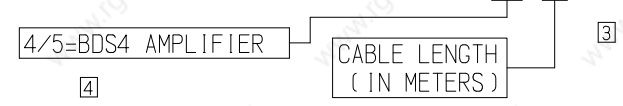

Kollmorgen Industrial Drives
 RADFORD, VIRGINIA

GOLDLINE AMPLIFIER ASSEMBLY
 GUIDE FOR RESOLVER CABLES

DWN. BY: EWR	DATE 10-07-92	CHK. BY:	DATE	APP'D. BY:	DATE	SCALE 1:1	DWG. NO. A-93540	SHEET 9 OF 13	ISSUE 5
-----------------	------------------	----------	------	------------	------	--------------	---------------------	---------------	------------

ISS.	ECN NO.	DATE	APP'D.	ISS.	ECN NO.	DATE	APP'D.

(W/CRIMPED MOTOR CONNECTOR)
 GOLDLINE RESOLVER CABLE WITH THERMOSTAT AND TACH (GCA-RT-X/X-XX)

PARTS LIST

CABLE				
ITEM #	DESCRIPTION	ID PART NUMBER	MANUFACTURER	
			NAME	PART NUMBER
#4	6 PAIR	A-96027-004	CAROL	S0573

MOTOR CONNECTOR AND ACCESSORIES				
ITEM #	DESCRIPTION	ID PART NUMBER	MANUFACTURER	
			NAME	PART NUMBER
#5	MOTOR HOUSING	A-93613-001	POWELL	IN75-69622-14S
#7	CRIMP CONTACT	A-93614-001	POWELL	10-40556
#6	FILLER PLUG	A-93615-001	POWELL	10-405996-16
#7	REDUCER	A-93616-001	POWELL	10-74696-16
	CRIMP TOOL	N/A	BENDIX	M22520/1-01

BDS4 C2 OR BDS5 C3 AND ACCESSORIES				
ITEM #	DESCRIPTION	ID PART NUMBER	MANUFACTURER	
			NAME	PART NUMBER
#1	12 POS. HOUSING	A-83908-012	MOLEX	39-01-2125
#3	CRIMP PIN	A-83909-002	MOLEX	39-00-0039
	CRIMP TOOL	N/A	MOLEX	HTR-60622

BDS4 C1 AND ACCESSORIES				
ITEM #	DESCRIPTION	ID PART NUMBER	MANUFACTURER	
			NAME	PART NUMBER
#2	20 POS. HOUSING	A-83908-020	MOLEX	39-01-2205
#3	CRIMP PIN	A-83909-002	MOLEX	39-00-0039
	CRIMP TOOL	N/A	MOLEX	HTR-60622

CONNECTION CHART

MOTOR CONNECTION ITEM #5	* CABLE ITEM #4	BDS4 C2 or BDS5 C3 ITEM #1	BDS4 C1 ITEM #2
TERMINAL A	RED 1	TERMINAL 7	N/C
TERMINAL B	BLK 1	TERMINAL 1	TACH TERM. 12 TERM. 16 TERM. 5
N/C	SHIELD	TERMINAL 8	
TERMINAL C	RED 2	TERMINAL 3	
TERMINAL D	BLK 2	TERMINAL 9	
N/C	SHIELD	TERMINAL 2	
TERMINAL E	RED 3	TERMINAL 10	
TERMINAL F	BLK 3	TERMINAL 4	
N/C	SHIELD	TERMINAL 5	
TERMINAL N	SEE NOTE #1	N/C	
TERMINAL P			
TERMINAL R	RED 5	N/C	TACH TERM. 12 TERM. 16 TERM. 5
TERMINAL S	BLK 5		
N/C	SHIELD		
TERMINAL T	RED 6	CUSTOMER THERMOSTAT HOOK-UP	N/C
TERMINAL U	BLK 6		
N/C	SHIELD		

SEE SHEET 2 AND 3 FOR CONNECTOR DETAILS.

* THIS CABLE ASSEMBLY TO BE LABELED "GCA-RT-X/X-XX".



NOTE:

- RESOLVER END: CUT-OFF REMAINING PAIR 12.7MM (1/2") FROM CABLE JACKET AND FOLD BACK OVER JACKET, PLACE UNDER HEAT SHRINK. MOTOR END: CUT-OFF REMAINING PAIR EVEN WITH CABLE JACKET.

ISS.	ECN NO.	DATE	APP'D.	ISS.	ECN NO.	DATE	APP'D.

Kollmorgen Industrial Drives
 RADFORD, VIRGINIA

GOLDLINE AMPLIFIER ASSEMBLY
 GUIDE FOR RESOLVER CABLES

DWN. BY:	DATE	CHK. BY:	DATE	APP'D. BY:	DATE	SCALE	DWG. NO.	SHEET 10 OF 13	ISSUE
EWR	10-01-92					1:1	A-93540		5

(W/SOLDERED MOTOR CONNECTOR)
GOLDLINE RESOLVER CABLE WITH THERMOSTAT AND TACH (GCA-RT-X/X-XX)

PARTS LIST

CABLE				
ITEM #	DESCRIPTION	ID PART NUMBER	MANUFACTURER	
			NAME	PART NUMBER
#4	6 PAIR	A-96027-004	CAROL	S0573

MOTOR CONNECTOR AND ACCESSORIES				
ITEM #	DESCRIPTION	ID PART NUMBER	MANUFACTURER	
			NAME	PART NUMBER
#5	MOTOR HOUSING	G-10158	BENDIX	MS3106E-22-14S

BDS4 C2 OR BDS5 C3 AND ACCESSORIES				
ITEM #	DESCRIPTION	ID PART NUMBER	MANUFACTURER	
			NAME	PART NUMBER
#1	12 POS. HOUSING	A-83908-012	MOLEX	39-01-2125
#3	CRIMP PIN	A-83909-002	MOLEX	39-00-0039
	CRIMP TOOL	N/A	MOLEX	HTR-60622

BDS4 C1 AND ACCESSORIES				
ITEM #	DESCRIPTION	ID PART NUMBER	MANUFACTURER	
			NAME	PART NUMBER
#2	20 POS. HOUSING	A-83908-020	MOLEX	39-01-2205
#3	CRIMP PIN	A-83909-002	MOLEX	39-00-0039
	CRIMP TOOL	N/A	MOLEX	HTR-60622

CONNECTION CHART

MOTOR CONNECTION ITEM #5	* CABLE ITEM #4	BDS4 C2 or BDS5 C3 ITEM #1	BDS4 C1 ITEM #2
TERMINAL A	RED 1	TERMINAL 7	N/C
TERMINAL B	BLK 1	TERMINAL 1	TACH TERM. 12 TERM. 16 TERM. 5
N/C	SHIELD	TERMINAL 8	
TERMINAL C	RED 2	TERMINAL 3	
TERMINAL D	BLK 2	TERMINAL 9	
N/C	SHIELD	TERMINAL 2	
TERMINAL E	RED 3	TERMINAL 10	
TERMINAL F	BLK 3	TERMINAL 4	
N/C	SHIELD	TERMINAL 5	
TERMINAL N	SEE NOTE #1	N/C	
TERMINAL P			
TERMINAL R	RED 5	N/C	TACH TERM. 12 TERM. 16 TERM. 5
TERMINAL S	BLK 5		
N/C	SHIELD		
TERMINAL T	RED 6	CUSTOMER THERMOSTAT HOOK-UP	N/C
TERMINAL U	BLK 6		
N/C	SHIELD		

SEE SHEET 2 AND 3 FOR CONNECTOR DETAILS.
 * THIS CABLE ASSEMBLY TO BE LABELED "GCA-RT-X/X-XX".



NOTE:
 1. RESOLVER END: CUT-OFF REMAINING PAIR 12.7MM (1/2") FROM CABLE JACKET AND FOLD BACK OVER JACKET, PLACE UNDER HEAT SHRINK.
 MOTOR END: CUT-OFF REMAINING PAIR EVEN WITH CABLE JACKET.

Kollmorgen Industrial Drives
RADFORD, VIRGINIA

GOLDLINE AMPLIFIER ASSEMBLY
 GUIDE FOR RESOLVER CABLES

ISS.	ECN NO.	DATE	APP'D.	ISS.	ECN NO.	DATE	APP'D.

DWN. BY:	DATE	CHK. BY:	DATE	APP'D. BY:	DATE	SCALE	DWG. NO.	SHEET 11 OF 13	ISSUE
EWR	10-01-92					1:1	A-93540		5

(W/CRIMPED MOTOR CONNECTOR)

GOLDLINE RESOLVER CABLE WITH THERMOSTAT, BRAKE, AND TACH (GCA-RBT-X/X-XX)

PARTS LIST

CABLE				
ITEM #	DESCRIPTION	ID PART NUMBER	MANUFACTURER	
			NAME	PART NUMBER
#4	6 PAIR	A-96027-004	CAROL	S0573

MOTOR CONNECTOR AND ACCESSORIES				
ITEM #	DESCRIPTION	ID PART NUMBER	MANUFACTURER	
			NAME	PART NUMBER
#5	MOTOR HOUSING	A-93613-001	POWELL	IN75-69622-14S
#7	CRIMP CONTACT	A-93614-001	POWELL	10-40556
#6	FILLER PLUG	A-93615-001	POWELL	10-405996-16
#7	REDUCER	A-93616-001	POWELL	10-74696-16
	CRIMP TOOL	N/A	BENDIX	M22520/1-01

BDS4 C2 OR BDS5 C3 AND ACCESSORIES				
ITEM #	DESCRIPTION	ID PART NUMBER	MANUFACTURER	
			NAME	PART NUMBER
#1	12 POS. HOUSING	A-83908-012	MOLEX	39-01-2125
#3	CRIMP PIN	A-83909-002	MOLEX	39-00-0039
	CRIMP TOOL	N/A	MOLEX	HTR-60622

BDS4 C1 AND ACCESSORIES				
ITEM #	DESCRIPTION	ID PART NUMBER	MANUFACTURER	
			NAME	PART NUMBER
#2	20 POS. HOUSING	A-83908-020	MOLEX	39-01-2205
#3	CRIMP PIN	A-83909-002	MOLEX	39-00-0039
	CRIMP TOOL	N/A	MOLEX	HTR-60622

CONNECTION CHART

MOTOR CONNECTION ITEM #5	* CABLE ITEM #4	BDS4 C2 or BDS5 C3 ITEM #1	BDS4 C1 ITEM #2
TERMINAL A	RED 1	TERMINAL 7	N/C
TERMINAL B	BLK 1	TERMINAL 1	TACH TERM. 12 TERM. 16 TERM. 5
N/C	SHIELD	TERMINAL 8	
TERMINAL C	RED 2	TERMINAL 3	
TERMINAL D	BLK 2	TERMINAL 9	
N/C	SHIELD	TERMINAL 2	
TERMINAL E	RED 3	TERMINAL 10	
TERMINAL F	BLK 3	TERMINAL 4	
N/C	SHIELD	TERMINAL 5	
TERMINAL N	RED 4	CUSTOMER	
TERMINAL P	BLK 4	BRAKE	
N/C	SHIELD	HOOK-UP	
TERMINAL R	RED 5		
TERMINAL S	BLK 5	N/C	
N/C	SHIELD		
TERMINAL T	RED 6	CUSTOMER	N/C
TERMINAL U	BLK 6	THERMOSTAT	
N/C	SHIELD	HOOK-UP	

SEE SHEET 2 AND 3 FOR CONNECTOR DETAILS.

* THIS CABLE ASSEMBLY TO BE LABELED "GCA-RBT-X/X-XX".

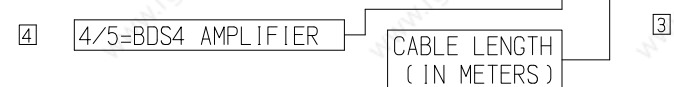

ISS.	ECN NO.	DATE	APP'D.	ISS.	ECN NO.	DATE	APP'D.

Kollmorgen Industrial Drives
RADFORD, VIRGINIA

GOLDLINE AMPLIFIER ASSEMBLY
GUIDE FOR RESOLVER CABLES

DWN. BY:	DATE	CHK. BY:	DATE	APP'D. BY:	DATE	SCALE	DWG. NO.	SHEET 12 OF 13	ISSUE
EWR	10-07-92					1:1	A-93540		5

(W/SOLDERED MOTOR CONNECTOR)

GOLDLINE RESOLVER CABLE WITH THERMOSTAT, BRAKE, AND TACH (GCA-RBT-X/X-XX)

PARTS LIST

CABLE				
ITEM #	DESCRIPTION	ID PART NUMBER	MANUFACTURER	
			NAME	PART NUMBER
#4	6 PAIR	A-96027-004	CAROL	S0573

MOTOR CONNECTOR AND ACCESSORIES				
ITEM #	DESCRIPTION	ID PART NUMBER	MANUFACTURER	
			NAME	PART NUMBER
#5	MOTOR HOUSING	G-10158	BENDIX	MS3106E-22-14S

BDS4 C2 OR BDS5 C3 AND ACCESSORIES				
ITEM #	DESCRIPTION	ID PART NUMBER	MANUFACTURER	
			NAME	PART NUMBER
#1	12 POS. HOUSING	A-83908-012	MOLEX	39-01-2125
#3	CRIMP PIN	A-83909-002	MOLEX	39-00-0039
	CRIMP TOOL	N/A	MOLEX	HTR-60622

BDS4 C1 AND ACCESSORIES				
ITEM #	DESCRIPTION	ID PART NUMBER	MANUFACTURER	
			NAME	PART NUMBER
#2	20 POS. HOUSING	A-83908-020	MOLEX	39-01-2205
#3	CRIMP PIN	A-83909-002	MOLEX	39-00-0039
	CRIMP TOOL	N/A	MOLEX	HTR-60622

CONNECTION CHART

MOTOR CONNECTION ITEM #5	* CABLE ITEM #4	BDS4 C2 or BDS5 C3 ITEM #1	BDS4 C1 ITEM #2
TERMINAL A	RED 1	TERMINAL 7	N/C
TERMINAL B	BLK 1	TERMINAL 1	TACH TERM. 12 TERM. 16 TERM. 5
N/C	SHIELD	TERMINAL 8	
TERMINAL C	RED 2	TERMINAL 3	
TERMINAL D	BLK 2	TERMINAL 9	
N/C	SHIELD	TERMINAL 2	
TERMINAL E	RED 3	TERMINAL 10	
TERMINAL F	BLK 3	TERMINAL 4	
N/C	SHIELD	TERMINAL 5	
TERMINAL N	RED 4	CUSTOMER	
TERMINAL P	BLK 4	BRAKE	
N/C	SHIELD	HOOK-UP	
TERMINAL R	RED 5		
TERMINAL S	BLK 5	N/C	
N/C	SHIELD		
TERMINAL T	RED 6	CUSTOMER	N/C
TERMINAL U	BLK 6	THERMOSTAT	
N/C	SHIELD	HOOK-UP	

SEE SHEET 2 AND 3 FOR CONNECTOR DETAILS.

* THIS CABLE ASSEMBLY TO BE LABELED "GCA-RBT-X/X-XX".

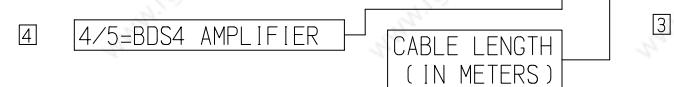

ISS.	ECN NO.	DATE	APP'D.	ISS.	ECN NO.	DATE	APP'D.

Kollmorgen Industrial Drives
RADFORD, VIRGINIA

GOLDLINE AMPLIFIER ASSEMBLY
GUIDE FOR RESOLVER CABLES

DWN. BY:	DATE	CHK. BY:	DATE	APP'D. BY:	DATE	SCALE	DWG. NO.	SHEET 13 OF 13	ISSUE
EWR	10-07-92					1:1	A-93540		5

INPUT
+/- 10V
MAX

DIFF HI
67-4
DIFF LO
67-1

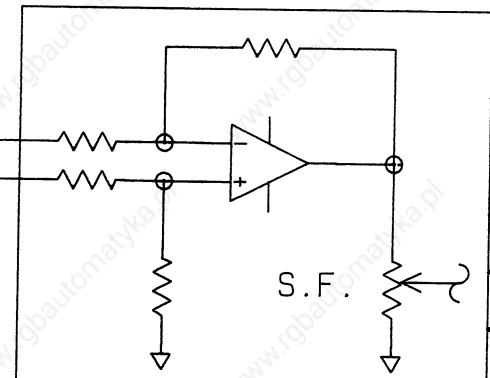

67-5
CW HI
5 TO 28VDC

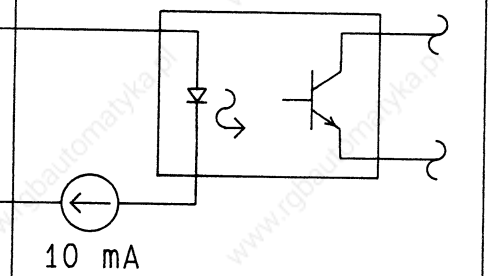

67-2
CW LO
10 mA

67-6
CCW HI
5 TO 28VDC

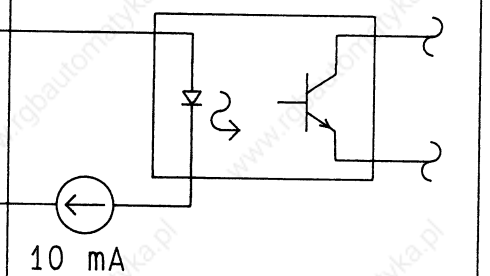

67-3
CCW LO
10 mA

DIRECTION LIMIT
OPTION BOARD

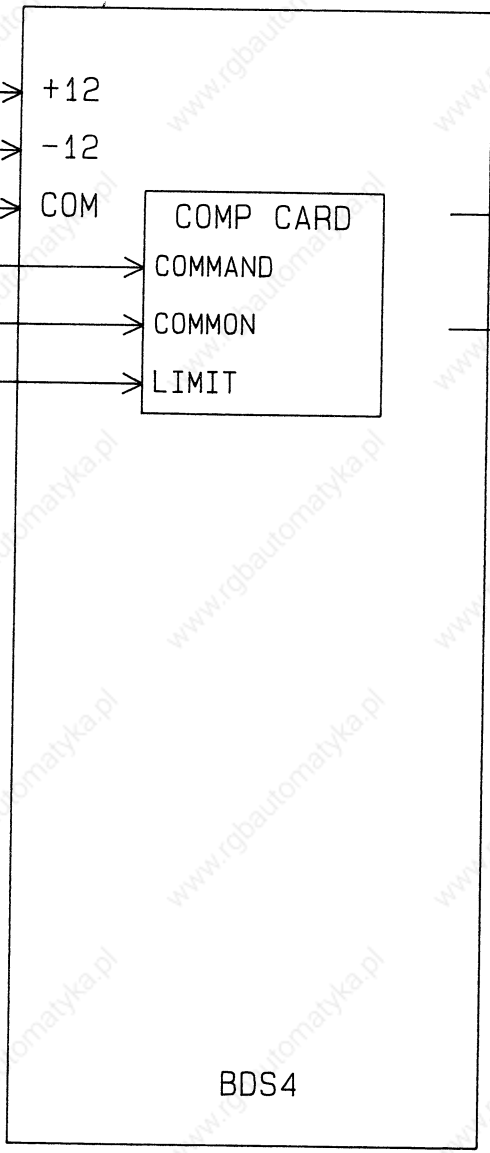

COMP CARD
COMMAND
COMMON
LIMIT

BDS4

C1 PIN 1
(DIFFERENTIAL
INPUT)
C1 PIN 11
DO NOT USE

UNLESS OTHERWISE SPECIFIED
XX DEC. PLACES ±.015
XXX DEC. PLACES ±.005
ANG. DIM. ±1 DEG.

DO NOT SCALE DWG. USE DIMENSIONS ONLY
ALL DIMENSIONS ARE INCHES
UNLESS OTHERWISE SPECIFIED

ISS.	ECN NO.	DATE	APP'D	ISS.	ECN NO.	DATE	APP'D	DW'N BY	DATE
				2	85576 LS	1/94	CJF	JMT	7-1-92
								CH'K BY	
								APP'D BY	
								CJF	7-20-92

ID INDUSTRIAL DRIVES
RADFORD, VIRGINIA
A KOLLMORGEN DIVISION

BDS4 DIRECTION LIMIT
WIRING DIAGRAM

SCALE	DWG. NO. A- 93541	ISSUE 2
-------	-----------------------------	-------------------

S COPY CODE

UNLESS OTHERWISE SPECIFIED
ANG. DIM. $\pm 1^\circ$

(METRIC)
X DEC. PLACES $\pm .4$
XX DEC. PLACES $\pm .13$

(INCHES)
XX DEC. PLACES $\pm .015$ IN.
XXX DEC. PLACES $\pm .005$ IN.

DO NOT SCALE DWG. USE DIMENSIONS ONLY.
ALL DIMENSIONS ARE MILLIMETERS WITH INCHES
IN PARENTHESES. UNLESS OTHERWISE SPECIFIED.

DWG. NO.
A-93567

ISSUE
3

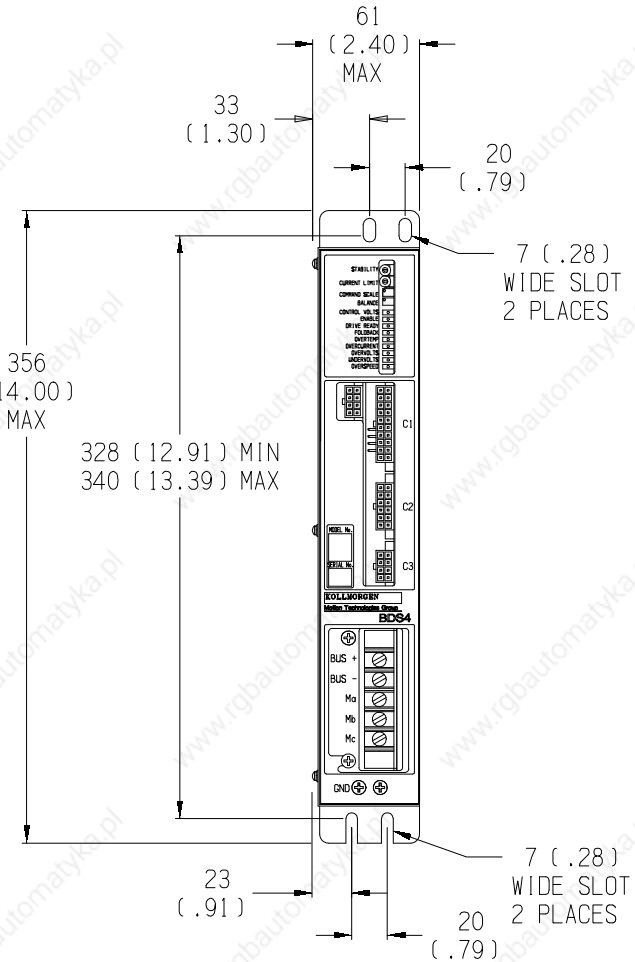
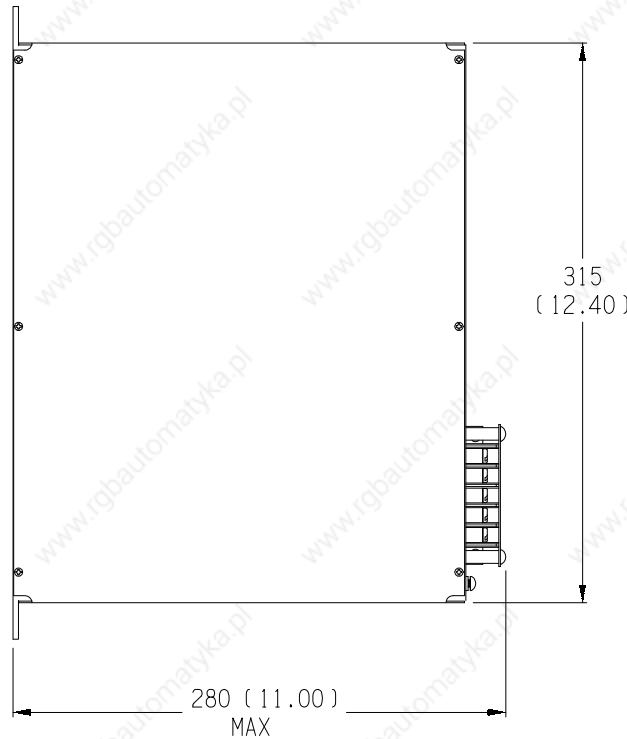
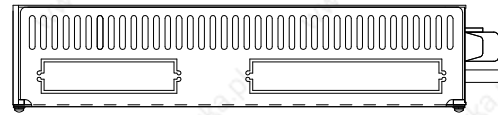

THIS UNIT CONTAINS STATIC SENSITIVE
MATERIAL, HANDLE ACCORDINGLY.

CAD DWG.

ISS.		COPY CODE		ISS.	ECN NO.	DATE	APP'D.	Kollmorgen Industrial Drives RADFORD, VIRGINIA				OUTLINE & DIMENSION				
ECN NO.		DATE	APP'D.	2	84919 TDG	1-7-93	CJF					BDS4A-3 & 6 AMP				
				3	87736 RRH	7-11-96		DWN. BY:	DATE	CHK. BY:	DATE	APP'D. BY:	DATE	PLOT SCALE	DWG. NO.	ISSUE
								EWR	8-03-92			CJF	8-03-92	1:4	A-93567	3

UNLESS OTHERWISE SPECIFIED
ANG. DIM. $\pm 1^\circ$

(METRIC)
X DEC. PLACES $\pm .4$
XX DEC. PLACES $\pm .13$

(INCHES)
XX DEC. PLACES $\pm .015$ IN.
XXX DEC. PLACES $\pm .005$ IN.

DO NOT SCALE DWG. USE DIMENSIONS ONLY.
ALL DIMENSIONS ARE MILLIMETERS WITH INCHES
IN PARENTHESES. UNLESS OTHERWISE SPECIFIED.

DWG. NO.
A-93568

ISSUE
3

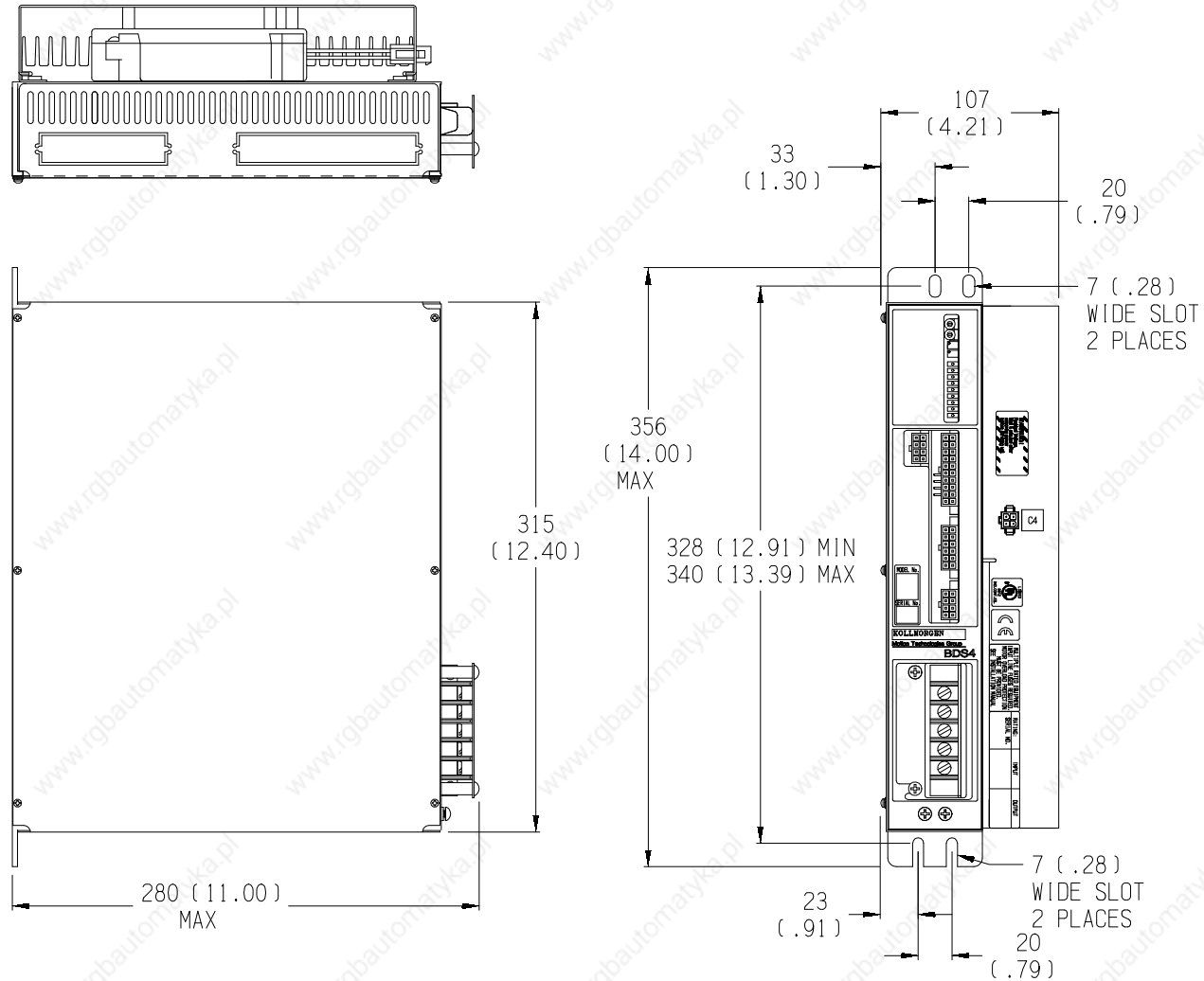

THIS UNIT CONTAINS STATIC SENSITIVE
MATERIAL, HANDLE ACCORDINGLY.

CAD DWG.

ISS.		I		COPY CODE	ISS.	ECN NO.	DATE	APP'D.	Kollmorgen Industrial Drives RADFORD, VIRGINIA						OUTLINE & DIMENSION		
ISS.		I		APP'D.											BDS4A-20AMP		
					2	84919 TDG	1-7-93	CJF							PLOT SCALE	DWG. NO.	ISSUE
					3	87736 RRH	7-11-96								DWN. BY:	DATE	CHK. BY:
									EWR	8-03-92			CJF	8-03-92			

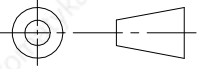

UNLESS OTHERWISE SPECIFIED
ANG. DIM. ±1 DEGREE

METRIC
X DEC. PLACES ±.4
XX DEC. PLACES ±.13

[INCHES]
XX DEC. PLACES ±.015 IN.
XXX DEC. PLACES ±.005 IN.

DO NOT SCALE DWG. USE DIMENSIONS ONLY.
ALL DIMENSIONS ARE MILLIMETERS.
UNLESS OTHERWISE SPECIFIED.

DWG. NO. SHT 1 OF 2
A-93656
ISSUE
1

THIRD ANGLE PROJECTION
METRIC

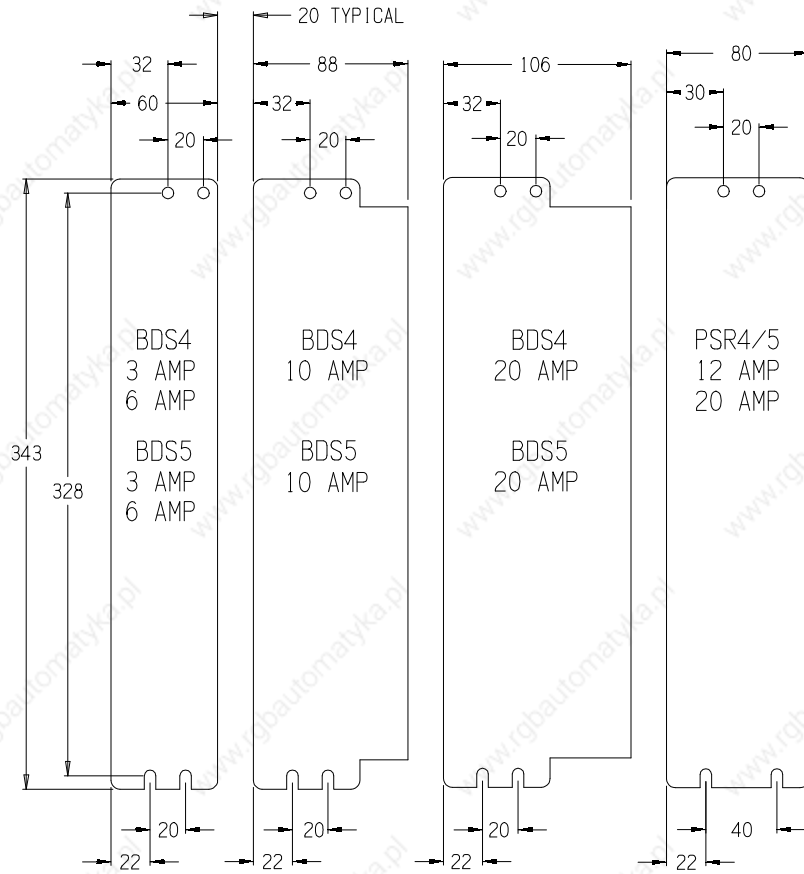

1-A 25mm MINIMUM FREE SPACE SHOULD BE MAINTAINED AROUND THE SYSTEM.
2-LOCATE THE HIGHEST CURRENT BDS4/5 AMPLIFIER NEXT TO THE PSR4/5 POWER SUPPLY AND REMAINING BDS4/5 AMPLIFIERS IN DESCENDING ORDER.

				B	COPY CODE				CAD DWG.								
ISS.	ECN NO.	DATE	APP'D.	ISS.	ECN NO.	DATE	APP'D.	Kollmorgen Industrial Drives RADFORD, VIRGINIA				MOUNTING HOLE PATTERN BDS4, BDS5, PSR4/5					
												DWN. BY:	DATE	CHK. BY:	DATE	APP'D. BY:	DATE
								TDG	11-06-92					1:4	A-93656		1

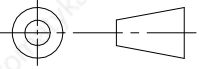

UNLESS OTHERWISE SPECIFIED
ANG. DIM. ±1 DEGREE

METRIC
X DEC. PLACES ±.4
XX DEC. PLACES ±.13

[INCHES]
XX DEC. PLACES ±.015 IN.
XXX DEC. PLACES ±.005 IN.

DO NOT SCALE DWG. USE DIMENSIONS ONLY.
ALL DIMENSIONS ARE MILLIMETERS.
UNLESS OTHERWISE SPECIFIED.

DWG. NO. SHT 2 OF 2
A-93656
1

THIRD ANGLE PROJECTION
METRIC

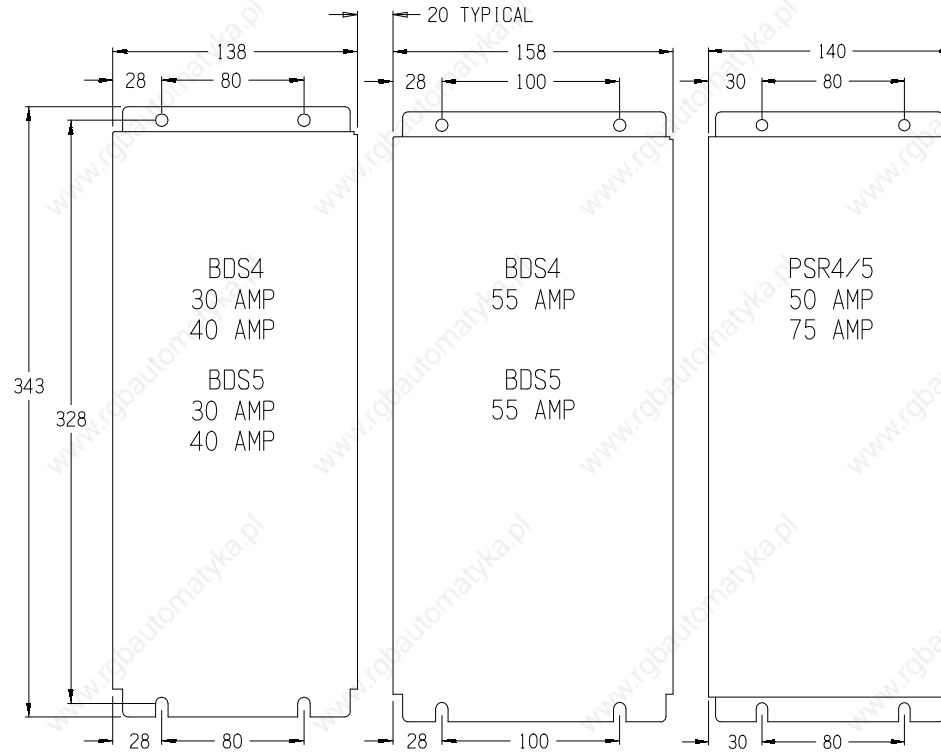

SEE NOTES ON SHEET 1.

COPY CODE				CAD DWG.													
ISS.	ECN NO.	DATE	APP'D.	ISS.	ECN NO.	DATE	APP'D.	Kollmorgen Industrial Drives RADFORD, VIRGINIA				MOUNTING HOLE PATTERN BDS4, BDS5, PSR4/5					
												DWN. BY:	DATE	CHK. BY:	DATE	APP'D. BY:	DATE
								TDG	11-06-92					1/4	A-93656		1

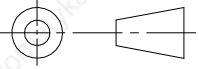

UNLESS OTHERWISE SPECIFIED
ANG. DIM. ±1 DEGREE

METRIC
X DEC. PLACES ±.4
XX DEC. PLACES ±.13

[INCHES]
XX DEC. PLACES ±.015 IN.
XXX DEC. PLACES ±.005 IN.

DO NOT SCALE DWG. USE DIMENSIONS ONLY.
ALL DIMENSIONS ARE MILLIMETERS WITH INCHES
IN BRACKETS. UNLESS OTHERWISE SPECIFIED.

DWG. NO.
A-93700

ISSUE
3

THIRD ANGLE PROJECTION
METRIC

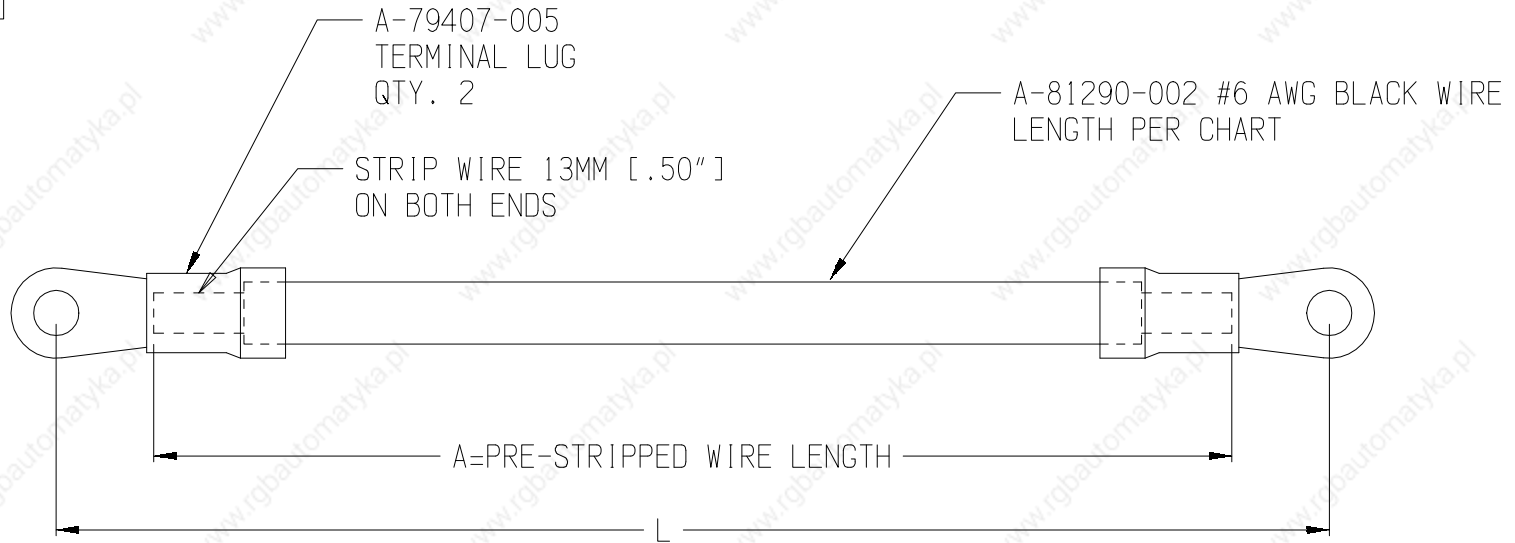

DASH NO.	A		L	
	MM	IN	MM	IN
100	72.5	2.86	100	3.94
120	94.5	3.72	122	4.80
160	132.5	5.22	160	6.30
180	152.5	6.00	180	7.09
200	174.5	6.87	202	7.95
220	192.5	7.58	220	8.66
230	202.5	7.97	230	9.06
240	212.5	8.37	240	9.45

③

CAD DWG.

ISS.	ECN NO.	DATE	APP' D.	S	COPY CODE

ISS.	ECN NO.	DATE	APP' D.
2	85246 LLS	05-17-92	CJF
3	86110 MAW	09-27-94	

Kollmorgen Industrial Drives
RADFORD, VIRGINIA

DC BUS CABLE ASSEMBLY
FOR BDS4/5 & PSR4/5

DWN. BY:	DATE	CHK. BY:	DATE	APP' D. BY:	DATE	SCALE	DWG. NO.	ISSUE
TDG	12-15-92			CJF	12-18-92	1:1	A-93700	3

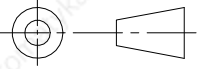

UNLESS OTHERWISE SPECIFIED
ANG. DIM. ±1 DEGREE

METRIC
X DEC. PLACES ±.4
XX DEC. PLACES ±.13

[INCHES]
XX DEC. PLACES ±.015 IN.
XXX DEC. PLACES ±.005 IN.

DO NOT SCALE DWG. USE DIMENSIONS ONLY.
ALL DIMENSIONS ARE MILLIMETERS.
UNLESS OTHERWISE SPECIFIED.

DWG. NO. SHT 1 OF 2
A-93703
ISSUE
2

THIRD ANGLE PROJECTION
METRIC

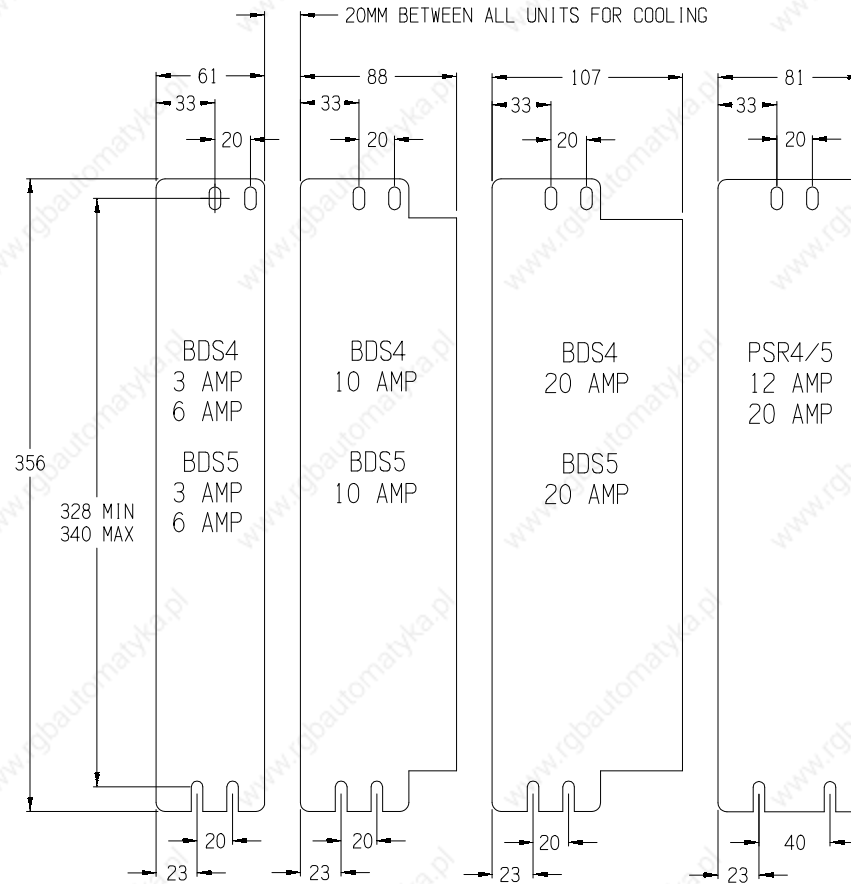

1-A 25mm MINIMUM FREE SPACE SHOULD BE MAINTAINED AROUND THE SYSTEM.
2-LOCATE THE HIGHEST CURRENT BDS4/5 AMPLIFIER NEXT TO THE PSR4/5 POWER SUPPLY AND REMAINING BDS4/5 AMPLIFIERS IN DESCENDING ORDER.

			B	COPY CODE
ISS.	ECN NO.	DATE	APP'D.	

ISS.	ECN NO.	DATE	APP'D.
2	84949 TDG	1-20-93	CJF

Kollmorgen Industrial Drives
RADFORD, VIRGINIA

DWN. BY:	DATE	CHK. BY:	DATE	APP'D. BY:	DATE
TDG	1-6-93			CJF	1-8-93

MOUNTING HOLE PATTERN
BDS4A, BDS5A, PSR4/5A

SCALE	DWG. NO.	SHT 1 OF 2	ISSUE
1:4	A-93703		2

CAD DWG.

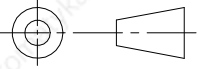

UNLESS OTHERWISE SPECIFIED
ANG. DIM. ±1 DEGREE

METRIC
X DEC. PLACES ±.4
XX DEC. PLACES ±.13

[INCHES]
XX DEC. PLACES ±.015 IN.
XXX DEC. PLACES ±.005 IN.

DO NOT SCALE DWG. USE DIMENSIONS ONLY.
ALL DIMENSIONS ARE MILLIMETERS.
UNLESS OTHERWISE SPECIFIED.

DWG. NO. SHT 2 OF 2
A-93703
ISSUE
2

THIRD ANGLE PROJECTION
METRIC

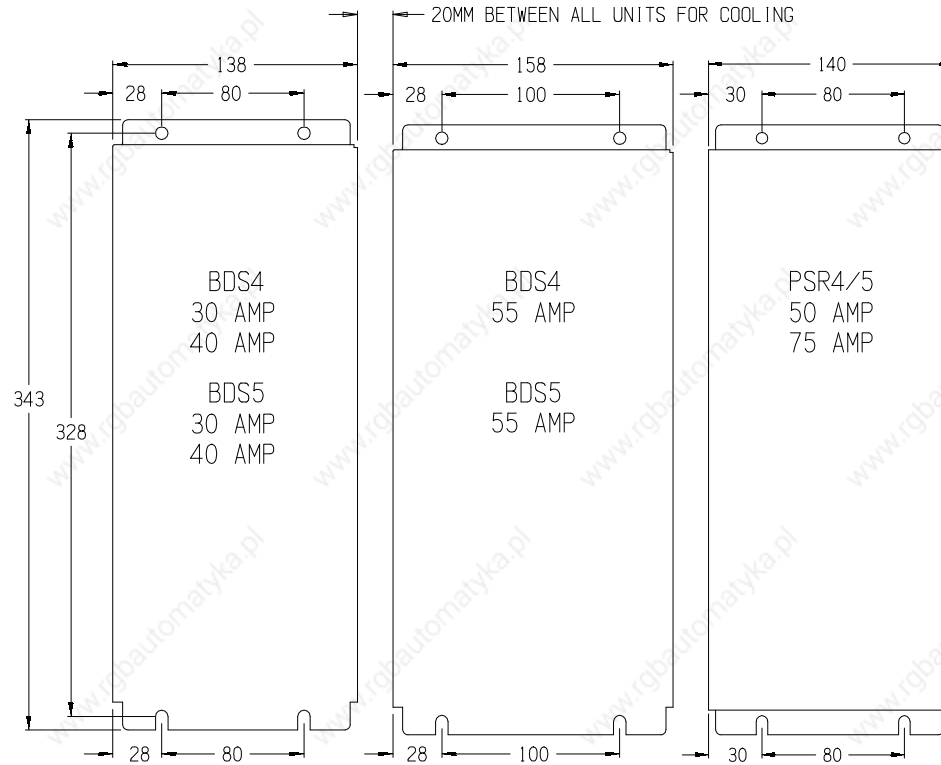

SEE NOTES ON SHEET 1.

COPY CODE

CAD DWG.

ISS.	ECN NO.	DATE	APP'D.	ISS.	ECN NO.	DATE	APP'D.

Kollmorgen Industrial Drives
RADFORD, VIRGINIA

MOUNTING HOLE PATTERN
BDS4A, BDS5A, PSR4/5A

DWN. BY:	DATE	CHK. BY:	DATE	APP'D. BY:	DATE
TDG	1-6-93				

SCALE	DWG. NO.	SHT 2 OF 2	ISSUE
1/4	A-93703		2

DO NOT SCALE DWG. USE DIMENSIONS ONLY.
 ALL DIMENSIONS ARE MILLIMETERS
 UNLESS OTHERWISE SPECIFIED.

UNLESS OTHERWISE SPECIFIED
 XX DEC. PLACES ±.015
 XXX DEC. PLACES ±.005
 ANG. DIM. ± 1°

DWG. NO. SH 1 OF 2 ISSUE
B- 84929 22

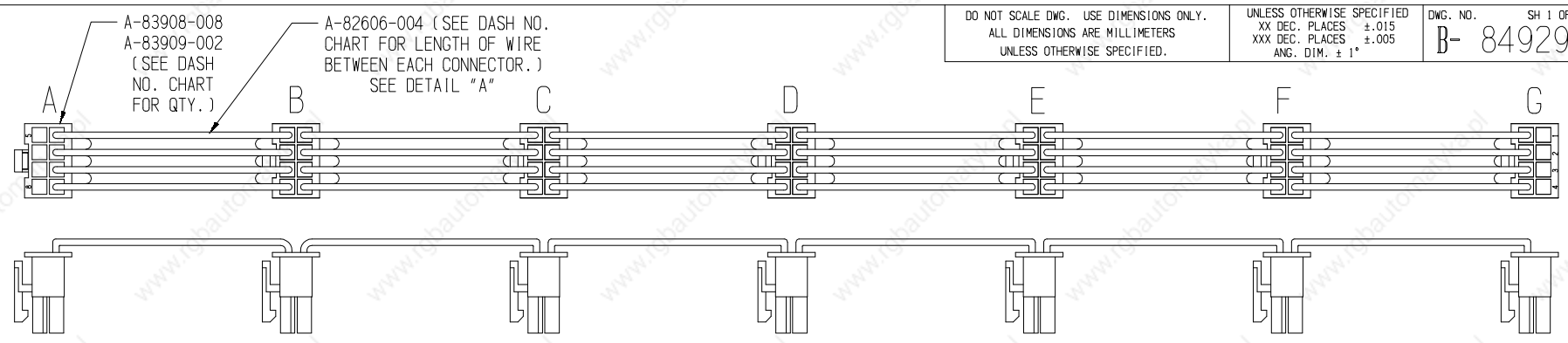

CONFIG.	CABLE LENGTH	CONFIG.	CABLE LENGTH	CONFIG.	CABLE LENGTH
-1-1-	111.75 (4.40)	-3-1-	151.75 (5.98)	-6-2-	211.75 (8.34)
-1-2-	111.75 (4.40)	-3-2-	151.75 (5.98)	-6-3-	211.75 (8.34)
-1-3-	111.75 (4.40)	-3-3-	151.75 (5.98)	-6-5-	211.75 (8.34)
-1-5-	111.75 (4.40)	-3-5-	151.75 (5.98)	-6-6-	211.75 (8.34)
-1-6-	111.75 (4.40)	-3-6-	151.75 (5.98)	-6-H-	311.75 (12.27)
-1-L-	131.75 (5.19)	-3-L-	171.75 (6.76)	-L-1-	111.75 (4.40)
-1-H-	211.75 (8.34)	-3-H-	271.75 (10.70)	-L-2-	111.75 (4.40)
-2-1-	131.75 (5.19)	-5-1-	191.75 (7.55)	-L-3-	111.75 (4.40)
-2-2-	131.75 (5.19)	-5-2-	191.75 (7.55)	-H-1-	111.75 (4.40)
-2-3-	131.75 (5.19)	-5-3-	191.75 (7.55)	-H-2-	111.75 (4.40)
-2-5-	131.75 (5.19)	-5-5-	191.75 (7.55)	-H-3-	111.75 (4.40)
-2-6-	131.75 (5.19)	-5-6-	191.75 (7.55)	-H-5-	111.75 (4.40)
-2-L-	151.75 (5.98)	-5-H-	291.75 (11.49)	-H-6-	111.75 (4.40)
-2-H-	231.75 (9.12)	-6-1-	211.75 (8.34)		

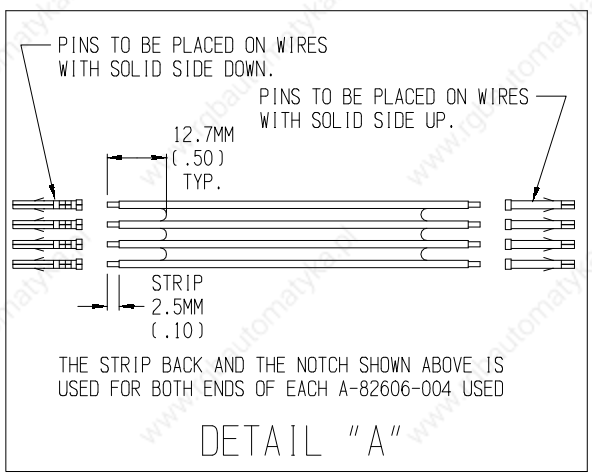

POSITION CODE CHART		
DESCRIPTION	CODE	
NO MODULE IN THIS POSITION	0	
BDS4 3 & 6 AMP	1	
BDS5 3 AMP	1	
BDS4 10 AMP	2	
BDS5 6 AMP	2	
BDS4 20 AMP	3	
BDS5 10 & 20 AMP	3	
BDS4 & 5 30 & 40 AMP	5	
BDS4 & 5 55 AMP	6	
PSR4/5 12 & 20 AMP	L	
PSR4/5 50 & 75 AMP	H	

NOTES:
 SEE DWG. A-84050 FOR SPACING BETWEEN UNITS.

NOTE:
 FOLLOWING IS THE MAX. NO. AMPLIFIERS THAT CAN BE RUN W/ A PARTICULAR POWER SUPPLY:

P.S.	BDS4 LO	BDS4 HI	BDS5 LO	BDS5 HI
12	4	0	3	0
20	4	0	3	0
50	8	6	6	6
75	8	6	6	6

22	302746	MTP	5/99						
MATERIAL:				FINISH:					
ISS.	ECN NO.	DATE	APP'D.	ISS.	ECN NO.	DATE	APP'D.	DW'N. BY:	DATE
7	84473	9/92	CJF	2	83952	4/91	CJF	VA	5/90
8	84799	10-92	CJF	3	84137	8/91	CJF	FDO	2/91
9	84903	12-92	CJF	4	84363	3/92	CJF	SCM	2-28 91
10	85255	5-93	CJF	5	84473	5/92	FDO		
11	85313	6-93	CJF	6	84546	6/92	CJF		

CAD DWG

Kollmorgen Industrial Drives
 RADFORD, VIRGINIA

BDS4 AND BDS5
 LOGIC CABLE ASSEMBLY

PLOT SCALE: 1:1 DWG. NO. **B- 84929** SH 1 OF 2 ISSUE 22

K B C COPY CODE

DASH NUMBER CHART

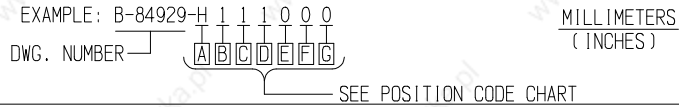

DO NOT SCALE DWG. USE DIMENSIONS ONLY. UNLESS OTHERWISE SPECIFIED. ALL DIMENSIONS ARE MILLIMETERS UNLESS OTHERWISE SPECIFIED.
 UNLESS OTHERWISE SPECIFIED XX DEC. PLACES ±.015 XXX DEC. PLACES ±.005 ANG. DIM. ± 1°
 DWG. NO. SH 2 OF 2 ISSUE B- 84929 22

DASH NO.	CONN QTY.	PIN QTY.	WIRE LENGTH FROM (CUT WIRE TO LENGTH SHOWN BELOW)						
			A TO B	B TO C	C TO D	D TO E	E TO F	F TO G	
4	12L0000	3	16	111.75 (4.40)	151.75 (5.98)	---	---	---	---
4	111L000	4	24	111.75 (4.40)	111.75 (4.40)	131.75 (5.19)	---	---	---
4	1L00000	2	8	131.75 (5.19)	---	---	---	---	---
4	23H3200	5	32	131.75 (5.19)	271.75 (10.70)	111.75 (4.40)	151.75 (5.98)	---	---
4	1111H32	7	48	111.75 (4.40)	111.75 (4.40)	111.75 (4.40)	211.75 (8.34)	111.75 (4.40)	151.75 (5.98)
5	111123H**	7	48	111.75 (4.40)	111.75 (4.40)	111.75 (4.40)	111.75 (4.40)	131.75 (5.19)	271.75 (10.70)
6	1111L00	5	32	111.75 (4.40)	111.75 (4.40)	111.75 (4.40)	131.75 (5.19)	---	---
7	H555000	4	24	111.75 (4.40)	191.75 (7.55)	191.75 (7.55)	---	---	---
7	55H6000	4	24	191.75 (7.55)	291.75 (11.49)	111.75 (4.40)	---	---	---
7	5H00000	2	8	291.75 (11.49)	---	---	---	---	---
8	555H000	4	24	191.75 (7.55)	191.75 (7.55)	291.75 (11.49)	---	---	---
8	H655000	4	24	111.75 (4.40)	211.75 (8.34)	191.75 (7.55)	---	---	---
18	H653200	5	32	111.75 (4.40)	211.75 (8.34)	191.75 (7.55)	151.75 (5.98)	---	---
19	3L00000	2	8	171.75 (6.67)	---	---	---	---	---
20	H533100	5	32	111.75 (4.40)	191.75 (7.55)	151.75 (5.98)	151.75 (5.98)	---	---

12* THIS CABLE ASSEMBLY MAY BE USED ON UNITS WITH 30MM OR LESS SPACING. 5** THIS CABLE ASSEMBLY MUST BE USED ONLY WITH BDS4 AMPLIFIERS!!

DASH NO.	CONN QTY.	PIN QTY.	WIRE LENGTH FROM (CUT WIRE TO LENGTH SHOWN BELOW)						
			A TO B	B TO C	C TO D	D TO E	E TO F	F TO G	
9	H111100	5	32	111.75 (4.40)	111.75 (4.40)	111.75 (4.40)	111.75 (4.40)	---	---
10	11L0000	3	16	111.75 (4.40)	131.75 (5.19)	---	---	---	---
11	2H00000	2	8	231.75 (9.12)	---	---	---	---	---
11	3H00000	2	8	271.75 (10.70)	---	---	---	---	---
11	6H00000	2	8	311.75 (12.27)	---	---	---	---	---
12	1L10000*	3	16	142.00 (5.59)	122.00 (4.80)	---	---	---	---
13	5H10000*	3	16	291.75 (11.49)	111.75 (4.40)	---	---	---	---
13	23H5100*	5	32	131.75 (5.19)	271.75 (10.70)	111.75 (4.40)	191.75 (7.55)	---	---
14	5H32000	4	24	291.75 (11.49)	111.75 (4.40)	151.75 (5.98)	---	---	---
16	1113L00	5	32	111.75 (4.40)	111.75 (4.40)	111.75 (4.40)	171.75 (6.76)	---	---
21	H333300	5	32	111.75 (4.40)	151.75 (5.98)	151.75 (5.98)	151.75 (5.98)	---	---
21	L220000	3	16	111.75 (4.40)	131.75 (5.19)	---	---	---	---
21	11H1111	7	48	111.75 (4.40)	211.75 (8.34)	111.75 (4.40)	111.75 (4.40)	111.75 (4.40)	111.75 (4.40)
22	22L0000	3	16	131.75 (5.19)	151.75 (5.98)	---	---	---	---

MATERIAL:				FINISH:					
ISS.	ECN NO.	DATE	APP'D.	ISS.	ECN NO.	DATE	APP'D.		
17	86729	TG	4/95	SCM	12	85401	TG	9/93	CJF
18	86900	JMM	6/95	SCM	13	85732	TG	3/94	CJF
19	87660	ESS	2/96	MB	14	86172	TG	10/94	CJF
20	88150	DEZ	7/96	FDO	15	86492	TG	02/95	CJF
21	88669	ESS	12/96	MB	16	86637	AL	03/95	CJF

Kollmorgen Industrial Drives
 RADFORD, VIRGINIA

BDS4 AND BDS5
 LOGIC CABLE ASSEMBLY

PLOT SCALE: 1:1 DWG. NO. SH 2 OF 2 ISSUE B- 84929 22

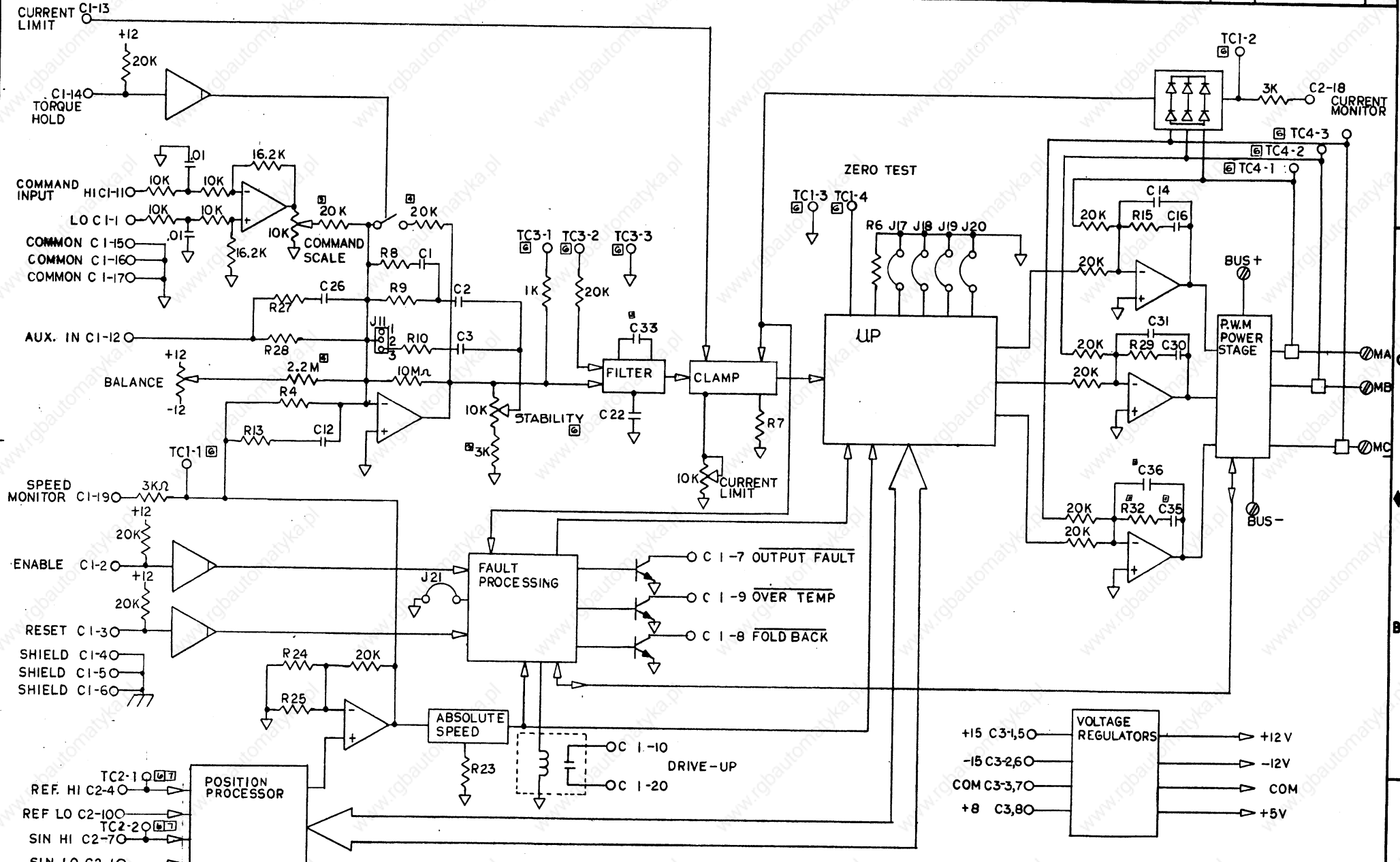

NOTES: ALL RX'S, CX'S, AND JX'S ARE COMPENSATION BOARD COMPONENTS

COMPONENT NO.

	BDS4	TC1	TC2	TC3	TC4
3-20 AMP	84	148	8	78	
30-55 AMP	103	145	119	224	

Q/N/C/B COPY CODE

MATERIAL				HEAT TREAT				FINISH			
NO.	QTY	DATE	APP'D.	NO.	QTY	DATE	APP'D.	NO.	QTY	DATE	APP'D.
7	1	84-578	OWENS	2	1	84-578	OWENS	2	1	84-578	OWENS
3	1	83-19	ALLI	3	1	83-19	ALLI	3	1	83-19	ALLI
4	1	83-46	BEARHEAVY	4	1	83-46	BEARHEAVY	4	1	83-46	BEARHEAVY
5	1	83-172	OWENS	5	1	83-172	OWENS	5	1	83-172	OWENS
6	1	84-050	LS	6	1	84-050	LS	6	1	84-050	LS

INDUSTRIAL DRIVES
 Radford, Virginia
 A HOLLANDER DIVISION

BDS4 SIMPLIFIED SCHEMATIC

SCALE: PART
 DWG. NO. 84113
 ISSUE 7

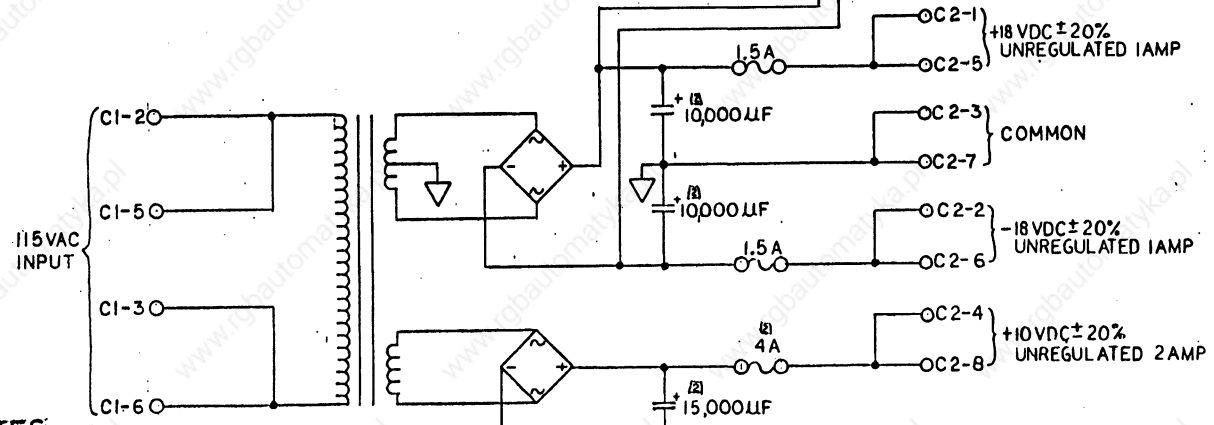
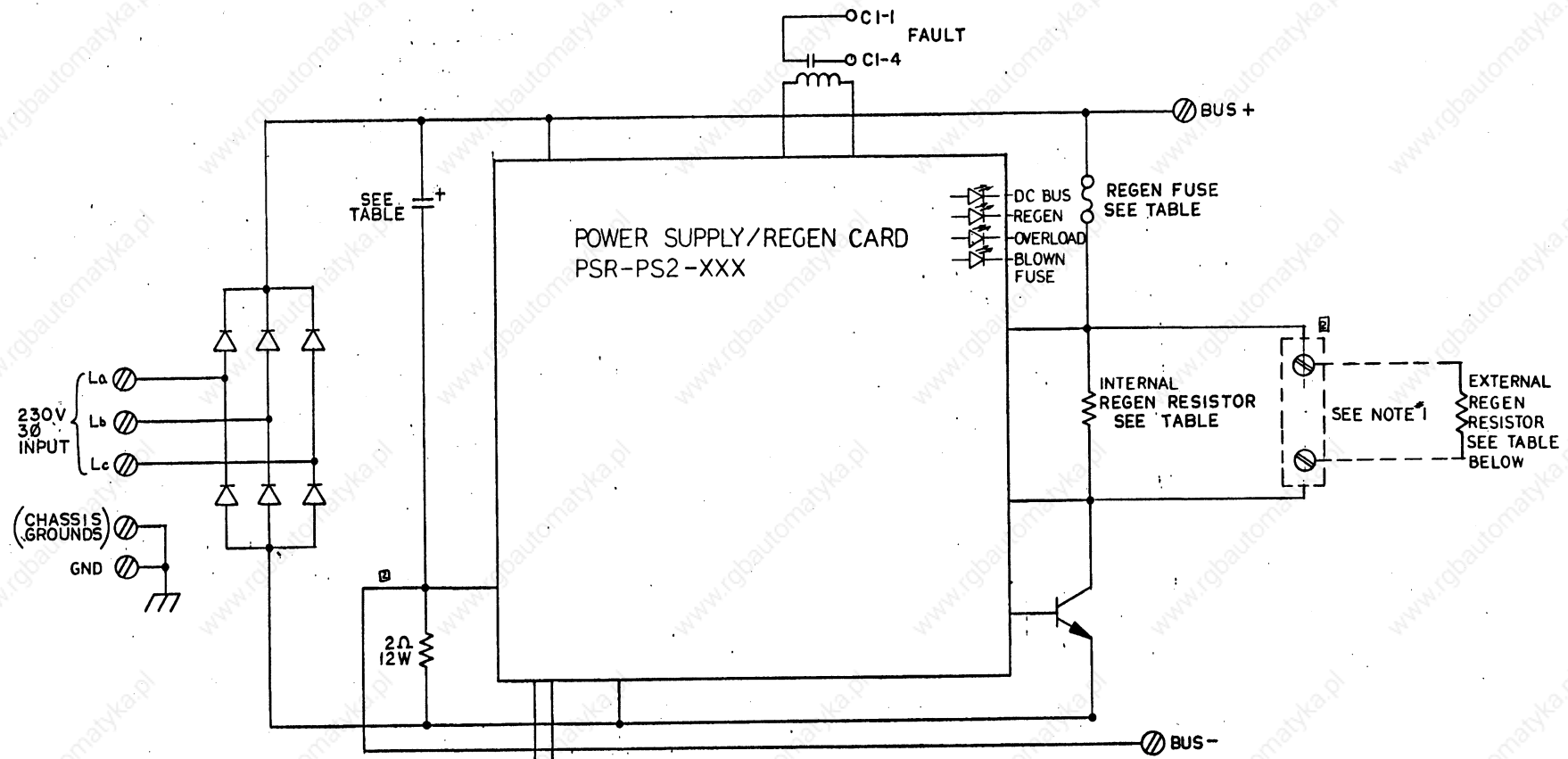

SEE NOTE 2

REGENERATION CAPABILITY	MODEL	REGEN RESISTOR	REGEN FUSE	CAP
40W	PSR4/5-212	25Ω 100W	5A	1650µF
40W	PSR4/5-220	12.5Ω 200W	8A	2970µF
40W	PSR4/5-112	15Ω 100W	5A	1650µF
40W	PSR4/5-120	7.5Ω 200W	7A	2970µF
400W	PSR4/5-212-XXX1	8.8Ω 750W	12A	1650µF
400W	PSR4/5-220-XXX1	8.8Ω 750W	12A	2970µF
200W	PSR4/5-112-XXX2	5.5Ω 500W	8A	1650µF
200W	PSR4/5-120-XXX2	5.5Ω 500W	8A	2970µF

SEE NOTE 3

- NOTES**
- 1)-TERMINAL BLOCK PROVIDED ONLY ON EXTERNAL REGEN RESISTOR MODELS. NO INTERNAL REGEN RESISTOR PROVIDED ON EXTERNAL RESISTOR MODEL.
 - 2)-THESE VALUES FOR INTERNAL REGEN ONLY.
 - 3)-THESE VALUES FOR EXTERNAL REGEN ONLY.

MATERIAL		HEAT TREAT		FINISH							
NO.	QTY	DATE	APP'D.	NO.	QTY	DATE	APP'D.	NO.	QTY	DATE	APP'D.
2	1	8/3/80	SCM	2	1	8/3/80	SCM	2	1	8/3/80	SCM
3	1	8/17/80	L.G.	3	1	8/17/80	L.G.	3	1	8/17/80	L.G.

INDUSTRIAL DRIVES
Radford, Virginia
A HOLLANDSBROS. DIVISION

PSR4/5 SIMPLIFIED SCHEMATIC

SCALE: **C** DWG. NO. **84723** LIST NO. **3**

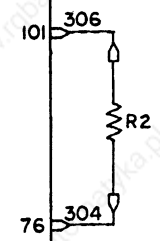
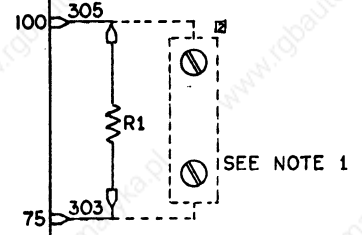
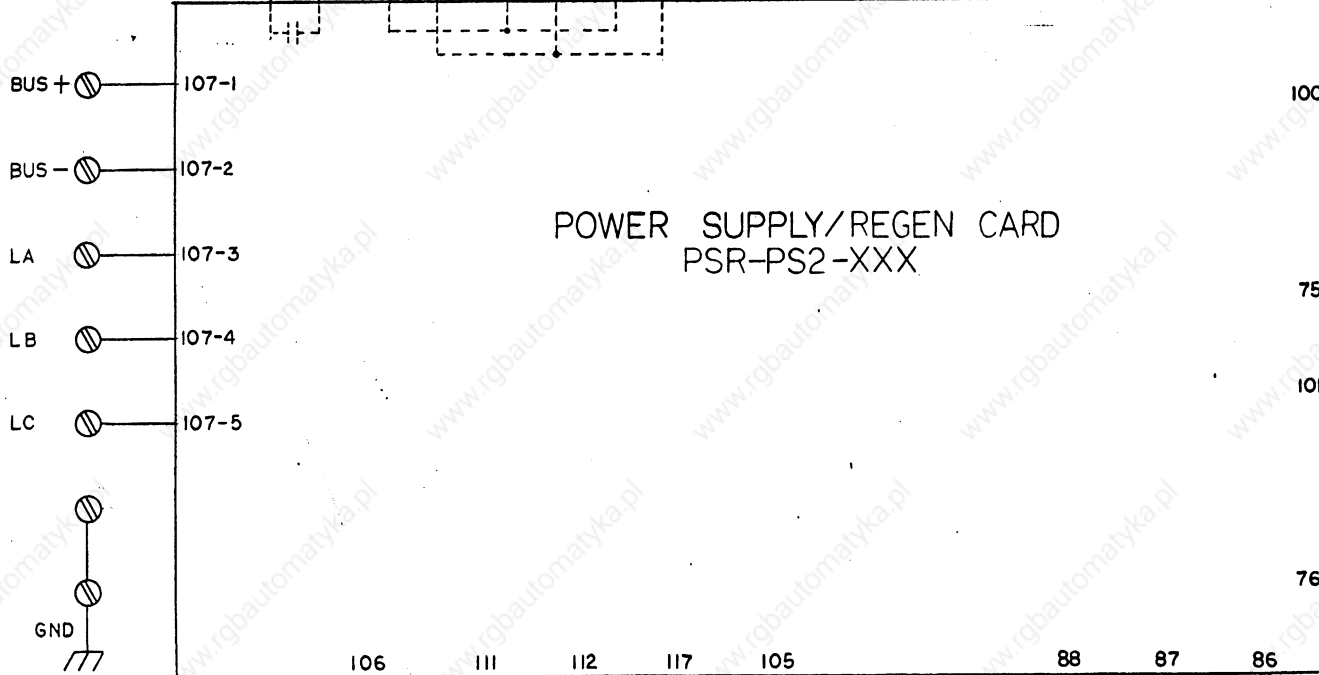
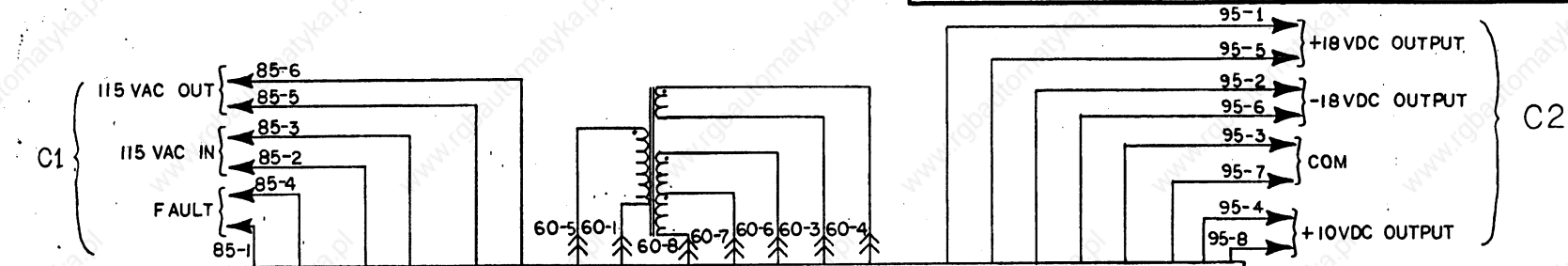

NOTES:
1. TERMINAL BLOCK ONLY ON EXTERNAL REGEN RESISTOR VERSION. THEN R1 AND R2 ARE OMITTED.

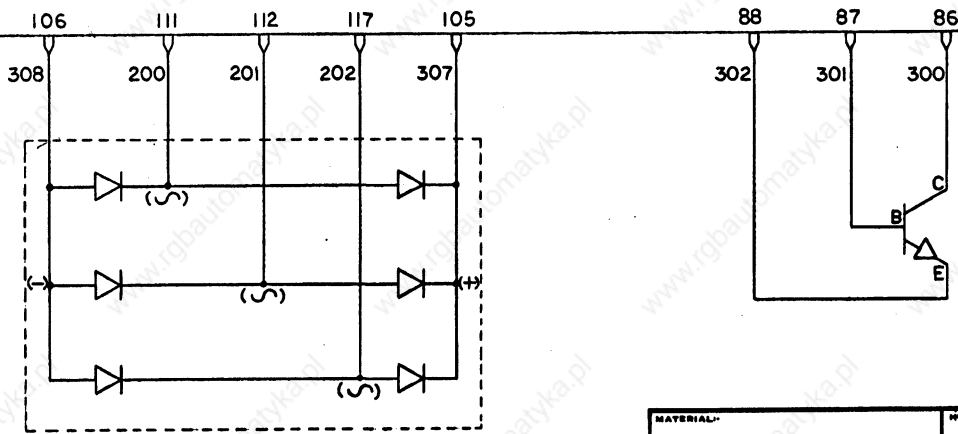

PSR	R 1	R 2
112	15Ω 100W	—
212	25Ω 100W	—
120	15Ω 100W	15Ω 100W
220	25Ω 100W	25Ω 100W

MATERIAL				HEAT TREAT				FINISH			
NO.	QTY	DATE	APP'D.	NO.	QTY	DATE	APP'D.	NO.	QTY	DATE	APP'D.
2	1	2/27/77	OWENS	3	1	2/27/77	OWENS	2	1	2/27/77	OWENS
3	1	2/27/77	OWENS								



INDUSTRIAL DRIVES
Bedford, Virginia
A BILLYGOVERN COMPANY

PSR4/5
INTERNAL SCHEMATIC

DWG. NO. 84724
REV. 3

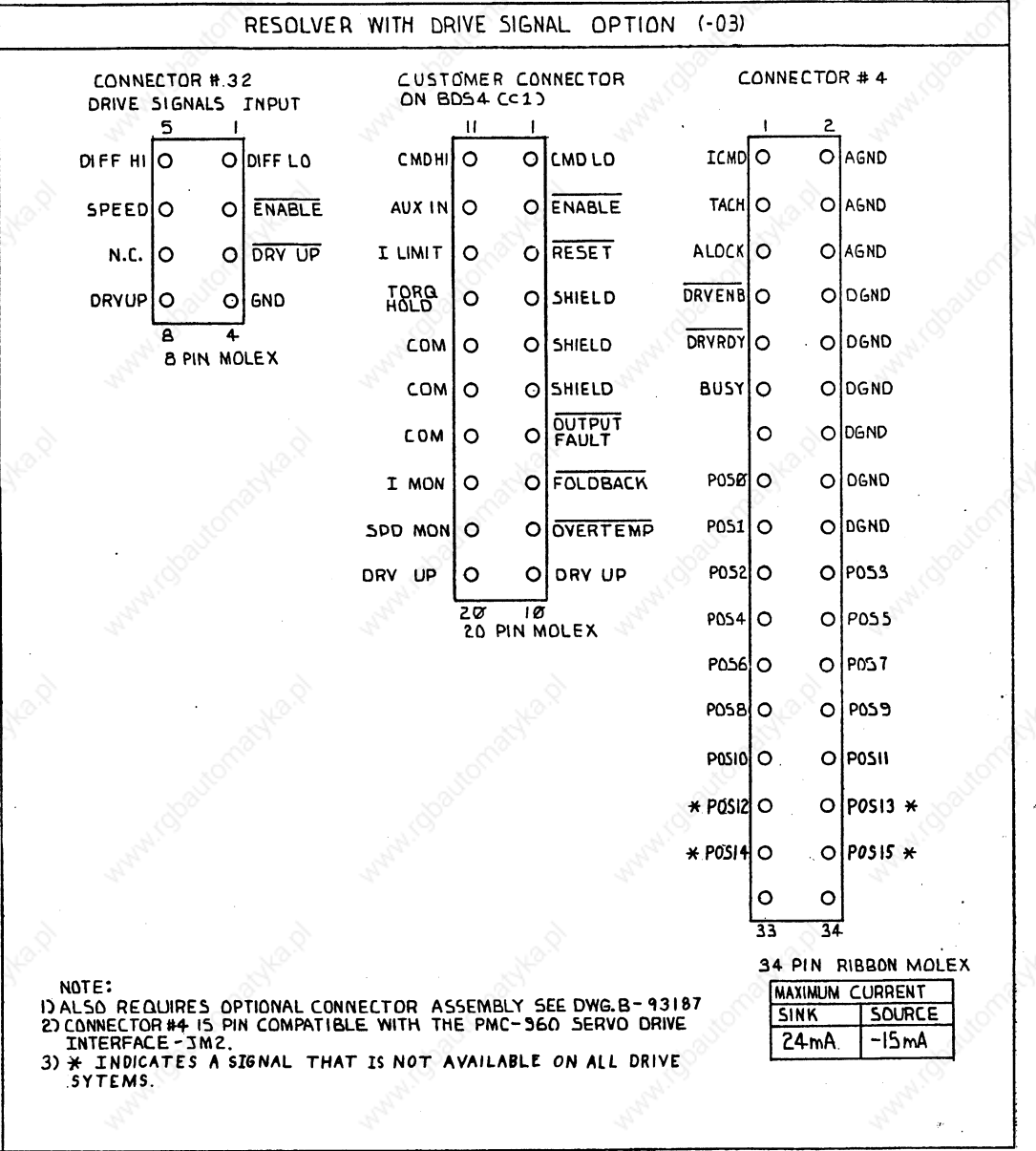
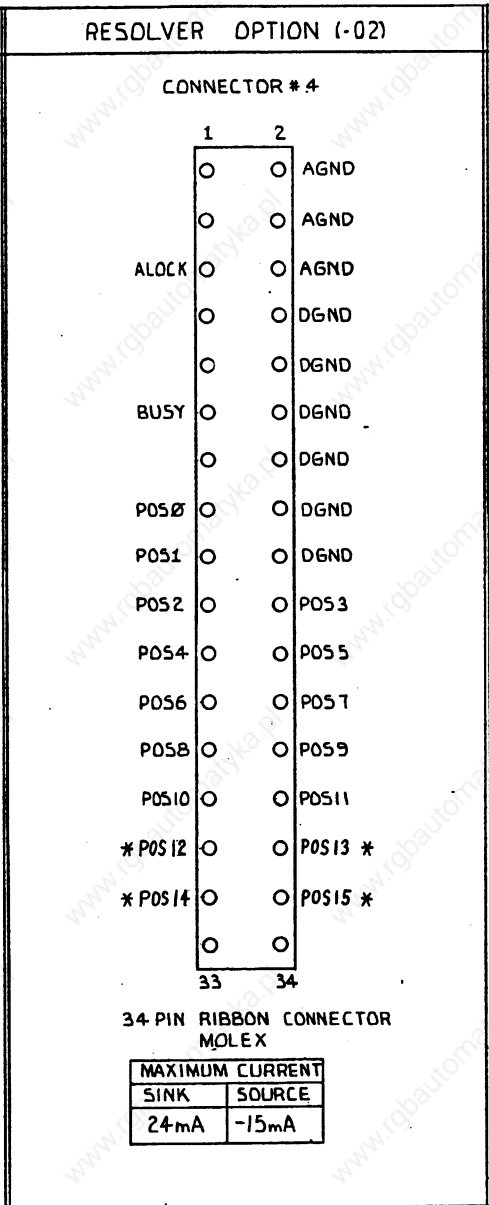
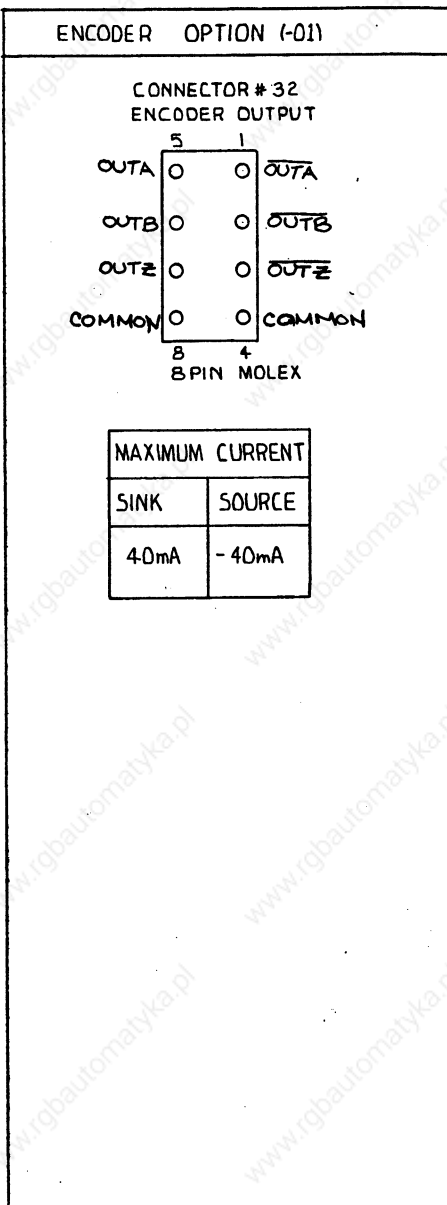

NOTE:
1) SEE D-93179 FOR PROPER JUMPER AND SWITCH SETTINGS
2) JUMPER 22,35 SELECTS ENCODER RESOLUTION
3) SWITCH 23,36 SERIES MARKER PULSE WIDTH
4) JUMPER 28 SELECTS THE ENCODER/RESOLVER MODE

MATERIAL				HEAT TREAT				FINISH							
NO.	ECN NO.	DATE	APP'D.	NO.	ECN NO.	DATE	APP'D.	NO.	ECN NO.	DATE	APP'D.	NO.	ECN NO.	DATE	APP'D.

INDUSTRIAL DRIVES
Radford, Virginia
A HOLLANDER DIVISION

BDS4-OPT2/3APINOUT
OPTIONS

SCALE: PART LIST NO.
DWG. NO. 93185. ISSUE 2.

GLOSSARY

Acceleration

The change in velocity as a function of time. Acceleration usually refers to increasing velocity and deceleration describes decreasing velocity.

Ambient Temperature

The temperature of the cooling medium, usually air, immediately surrounding the motor or another device.

Amplifier

Electronics which convert low level command signals to high power voltages and currents to operate a servo motor.

Brushless Servo Drive

A servo drive used to control a permanent magnet synchronous AC motor. May also be referred to as an AC Servo Drive.

Drive

This is the electronics portion of the system that controls power to the motor.

Drive, Analog

Usually referring to any type of motor drive in which the input is an analog signal.

Drive, Servo

A motor drive which utilizes internal feedback loops for accurate control of motor current and/or velocity.

Efficiency

The ratio of output power to input power.

Encoder, Absolute

A digital position transducer in which the output is representative of the absolute position of the input shaft within one (or more) revolutions. Output is usually a parallel digital word.

Encoder, Incremental

A position encoding device in which the output represents incremental changes in position.

Encoder, Marker

A once-per-revolution signal provided by some incremental encoders to specify a reference point within that revolution. Also known as Zero Reference signal or index pulse.

Encoder Resolution

A measure of the smallest positional change which can be detected by the encoder.

Feedback

A signal which is transferred from the output back to the input for use in a closed loop system.

Following Error

The position error during motion resulting from use of a position control loop with proportional gain only.

Friction

A resistance to motion caused by surfaces rubbing together. Friction can be constant with varying speed (coulomb friction) or proportional to speed (viscous friction) or present at rest (static friction).

Full Load Current

The armature current of a motor operated at its full load torque and speed with rated voltage applied.

Full Load Speed

The speed of a motor operated with rated voltage and full load torque.

Gain

The ratio of system output signal to system input signal. The control loop parameter that determines system performance characteristics.

HP: Horsepower

One horsepower is equal to 746 watts. Since $\text{Power} = \text{Torque} \times \text{Speed}$, horsepower is a measure of a motor's torque and speed capability (e.g. a 1 HP motor will produce 35 lb-in. at 1800 rpm).

I/O: Input/Output

The reception and transmission of information between control devices. In modern control systems, I/O has two distinct forms: switches, relays, etc., which are in either an on or off state, or analog signals that are continuous in nature such as speed, temperature, flow, etc.

Inertia

The property of an object to resist changes in velocity unless acted upon by an outside force. Higher inertia objects require larger torques to accelerate and decelerate. Inertia is dependent upon the mass and shape of the object.

Inertial Match

An inertial match between motor and load is obtained by selecting the coupling ratio such that the load moment of inertia referred to the motor shaft is equal to the motor moment of inertia.

Inrush Current

The current surge generated when a piece of equipment such as a servo amplifier is connected to an AC line. This surge is typically due to the impulse charging of a large capacitor located in the equipment.

Instability

Undesirable motion of an actuator that is different from the command motion. Instability can take the form of irregular speed or hunting of the final rest position.

Limits

Motion control systems may have sensors called limits that alert the control electronics that the physical end of travel is being approached and that motion should stop.

Logic Ground

An electrical potential to which all control signals in a particular system are referenced.

Loop, Feedback Control

A control method that compares the input from a measurement device, such as an encoder or tachometer, to a desired parameter, such as a position or velocity and causes action to correct any detected error. Several types of loops can be used in combination (i.e. velocity and position together) for high performance requirements.

Master Slave Motion Control

A type of coordinated motion control where the master axis position is used to generate one or more slave axis position commands.

Motor, AC

A device that converts electrical alternating current into mechanical energy. Requires no commutation devices such as brushes. Normally operated off commercial AC power. Can be single or multiple phase.

Oscillation

An effect that varies periodically between two values.

PLC

Programmable Logic Controller. Also known as a programmable controller, these devices are used for machine control and sequencing.

Power

The rate at which work is done. In motion control, $\text{Power} = \text{Torque} \times \text{Speed}$.

Pulse Rate

The frequency of the step pulses applied to a step-per motor driver. The pulse rate divided by the resolution of the motor/drive combination (in steps per revolution) yields the rotational speed in revolutions per second.

Ramping

The acceleration and deceleration of a motor. May also refer to the change in frequency of the applied step pulse train.

Rated Torque

The torque producing capacity of a motor at a given speed. This is the maximum continuous torque the

motor can deliver to a load and is usually specified with a torque/speed curve.

Regeneration

The action during motor braking, in which the motor acts as a generator and takes kinetic energy from the load, converts it to electrical energy, and returns it to the amplifier.

Repeatability

The degree to which the positioning accuracy for a given move performed repetitively can be duplicated.

Resolution

The smallest positioning increment that can be achieved. Frequently defined as the number of steps or feedback units required for a motor's shaft to rotate one complete revolution.

Resolver

A position transducer utilizing magnetic coupling to measure absolute shaft position over one revolution.

RMS Current

Root mean square current. In an intermittent duty cycle application, the RMS current is equal to the value of steady state current which would produce the equivalent resistive heating over a long period of time.

Rotor

The rotating part of a magnetic structure. In a motor, the rotor is connected to the motor shaft.

Servo Amplifier/Servo Drive

An electronic device which produces the winding current for a servo motor. The amplifier converts a low level control signal into high voltage and current levels to produce torque in the motor.

Servo System

An automatic feedback control system for mechanical motion in which the controlled or output quantity is position, velocity, or acceleration. Servo systems are closed loop systems.

Shunt Resistor

A device located in a servo amplifier for controlling regenerative energy generated when braking a motor. This device dissipates or "dumps" the kinetic energy as heat.

Single Point Ground

The common connection point for signal grounds in a control wiring environment.

Slew

In motion control the portion of a move made at a constant non-zero velocity.

Speed Regulation

For a speed control system, speed regulation is the variation in actual speed expressed as a percentage of set speed.

Stiffness

Ratio of an applied force torque to change in position for a mechanical system.

Stator

The non-rotating part of a magnetic structure. In a motor the stator usually contains the mounting surface, bearings, and non-rotating windings or permanent magnets.

Tachometer

An electromagnetic feedback transducer which produces an analog voltage signal proportional to rotational velocity. Tachometers can be either brush or brushless.

Torque

The rotary equivalent to force. Equal to the product of the force perpendicular to the radius of motion and distance from the center of rotation to the point where the force is applied.

Velocity

The change in position as a function of time. Velocity has both a magnitude and direction.

Underlined Text, 2-2

Unpacking, 2-2

Unregulated DC Voltages, 2-6

Ventilation, 4-2

Warning, 2-1

Warranty Information, *see* Appendix A

