

**PROJECTING NOTES  
FUNCTIONAL DESCRIPTION  
OPERATING INSTRUCTIONS**

**SVC 3000**



## 1. PROJECTING NOTES

### 1.1 General

### 1.2 Servo-amplifier

1.2.1 Power supply data

1.2.2 Technical data

1.2.3 Block schematic circuit diagram

1.2.4 Manufacturer designation

1.2.5 Mechanical data

### 1.3 Subrack

1.3.1 Types of feed input

1.3.2 Mechanical data

### 1.4 External components

1.4.1 Three-phase transformer

1.4.2 Smoothing choke

1.4.3 Generator load module (GLM)

## 2. FUNCTIONAL DESCRIPTION OF THE SERVO - AMPLIFIER

### 2.1 General

2.1.1 Design

2.1.2 Method of operating

### 2.2 Speed controller

2.2.1 Rotary speed reference value

2.2.2 Rotary speed reference value via differential input

2.2.3 Rotary speed actual value

2.2.4 Rotary speed adjustment

2.2.5 Offset adjustment

2.2.6 Servo control action

2.2.7 Hunting

- 2.3 **Curent limiters**
  - 2.3.1 Continuous current limitation
  - 2.3.2 Dynamic current limitation
  - 2.3.3 Torque reduction
  
- 2.4 **Protective devices**
  - 2.4.1 Auxiliary voltage monitor
  - 2.4.2 Over-voltage monitor
  - 2.4.3 Thermal monitoring of the power output stage
  - 2.4.4 Short-circuit, ground and earth fault monitoring
  - 2.4.5 I(2)t simulation
  - 2.4.6 Envelope regulator
  - 2.4.7 Fault message relay
  
- 2.5 **Inhibit inputs**
  - 2.5.1 Inhibit input "FS 1"
  - 2.5.2 Inhibit input "FS 3"
  - 2.5.3 Inhibit input "FS 4"
  - 2.5.4 Release
  
- 2.6 **Other connections**
  - 2.6.1 Controller test
  
- 3. **PUTTING INTO OPERATION**
  - 3.1 **Connection regulations**
  
  - 3.2 **Direction of rotation**
  
  - 3.3 **Commissioning instructions**
    - 3.3.1 Trouble shooting
  
- 4. **CONNECTION DIAGRAMS (fuses)**
  
- 5. **PLANS**

# 1. PROJECTING NOTES

## 1.1 General aspects of DC servo drives

Series SVC DC servo-amplifiers are clocked transistor speed control units developed to operate DC motors excited by permanent-magnets. Their modular construction guarantees an inexpensive, space-optimized solution for single- and for multiple-axis versions.

A rotary speed regulating device together with a DC motor, a tacho-generator and a smoothing choke (only needed with low inductivity motors) provides a unit for dynamic speed control.

Block schematic circuit diagram of DC drive with cascaded regulation

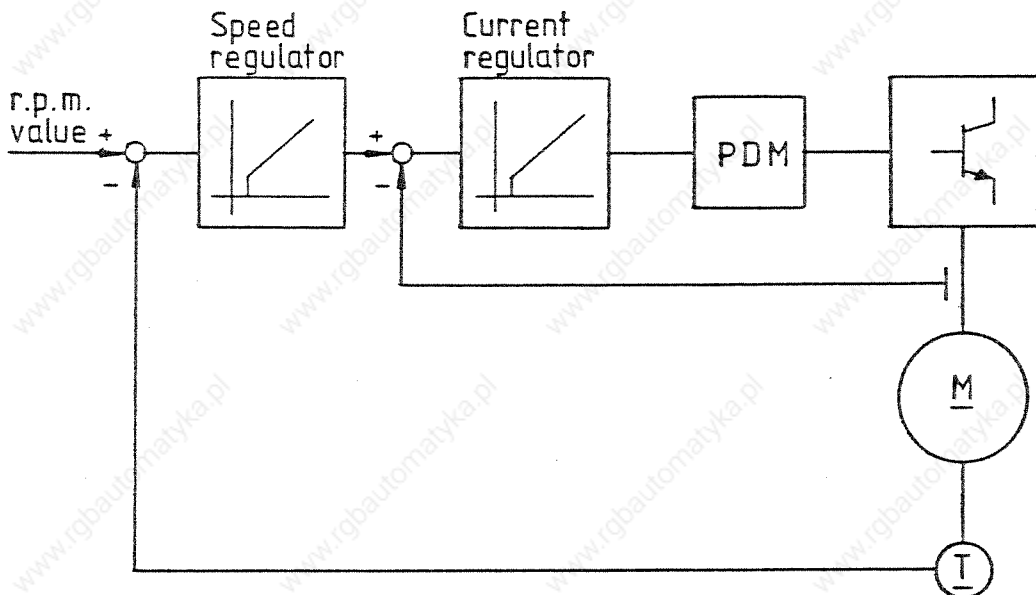

03-BSB-RGG-ABC-4856

The configuration of the amplifier output stage is H-bridge, and allows the motor to be operated in all four quadrants.

As a multiple-axis in the 19"-subrack height 7 SHU, it can accommodate maximum 7 individual amplifiers. The individual units can be plugged from the front; unoccupied plug-in positions are always covered by dummy plates or can be operated with other HAUSER amplifiers in the mixed axis composite mode.

Two versions of the equipment are available:

- Model for 19" plug-in technology with plug-and-socket connector on the rear of the carrierboard.
- Model for wall mounting width 19" and 300 mm, with terminal connections on front of the carrierboard.

The power voltage and the mains supply voltage are fed to the equipment through a common three-phase transformer with galvanic isolation and screen winding.

## 1.2 Servo - amplifier

### 1.2.1 Power supply data

SVC speed controller SVC 3000	Input data		
	Supply voltage 3 x E	Mains power supply	
		Voltage	Current
	65...85...130...178 V ①	220 V ②	0,3 A ③

- ① Standard voltages
- ② Mains voltage tolerance + 10% / - 15 %
- ③ Internal consumption excluding fan

SVC speed controller SVC 3000	Output data						
	Rated DC volts	Continuous current	Dynamic current	Rated power	Dynamic power	Max. external load	
						+15 V	-15 V
	60-200 V ①	15 A ②	30 A	3 kW	6 kW	200 mA	300 mA

- ① Output voltage adjustment range: 0 to 100 %
- ② Guaranteed range: 0 to 45 degrees Celsius  
Operating range: 0 degrees Celsius to + 60 degrees Celsius, but with current reduction of 2 %/K in ambient temperatures > 45 degrees Celsius  
Form factor under rated conditions: less than 1.01  
Continuous current greater than 8 A; connect cooling fan to terminal strip x 15 on carrierboard.

### 1.2.2 Technical data

- Output voltage 60 - 200 V self-regulating, without matching of working point
- Output current; max. adjustable stat. 15 A / dyn. 30 A (0,5 sec.)
- Working frequency 5 kHz; results in a motor clocking frequency of 10 kHz
- Control range 1 : 10.000
- Galvanically isolated output stage. Signal transmission via opto-coupler
- Desaturation monitor for output stage
- earth- (with earthed intermediate circuit voltage only) and short-circuits without additional choke
- Cascade current regulator for high control range
- Envelope regulator for speed-dependent current limiting
- I(2)t simulation with limiting value cut-out
- External torque limiter
- Separate right / left inhibit
- Differential input with separate offset matching or optionally two special inputs
- Reference voltage: - 10 V to 0 to + 10 V; input impedance approx. 13 kOhm
- Fault message contact (line-continuity fail-safe, contact loading: 48 V, 0,5 A, 10 W)
- Release; line-continuity fail-safe inhibit, signal level 2 to 15 V; or as signal input for higher-ranking position controllers able to operate a self-test routine whilst signalling
- Controller test; here a defined proportional gain specified for the speed controller to check the allocation of the feedback signals
- LED display to show the operating mode
- Output busbar connection
- 3-phase input 60 V AC to 180 V AC
- Rated current up to 8 A; operation without forced cooling
- Standard mains supply voltage 220 V (+ 10 % / - 15 %) 50 Hz, power consumption 0,26 A excluding fan
- Maximum external load of auxiliary voltage:
  - + 15 V voltage I max. ext. = 200 mA
  - 15 V voltage I max. ext. = 300 mA
- regulating range: 0 ... 100 %
- Guaranteed operating rang: 0 to 45 degrees Celsius

1.2.3 Block schematic circuit diagram

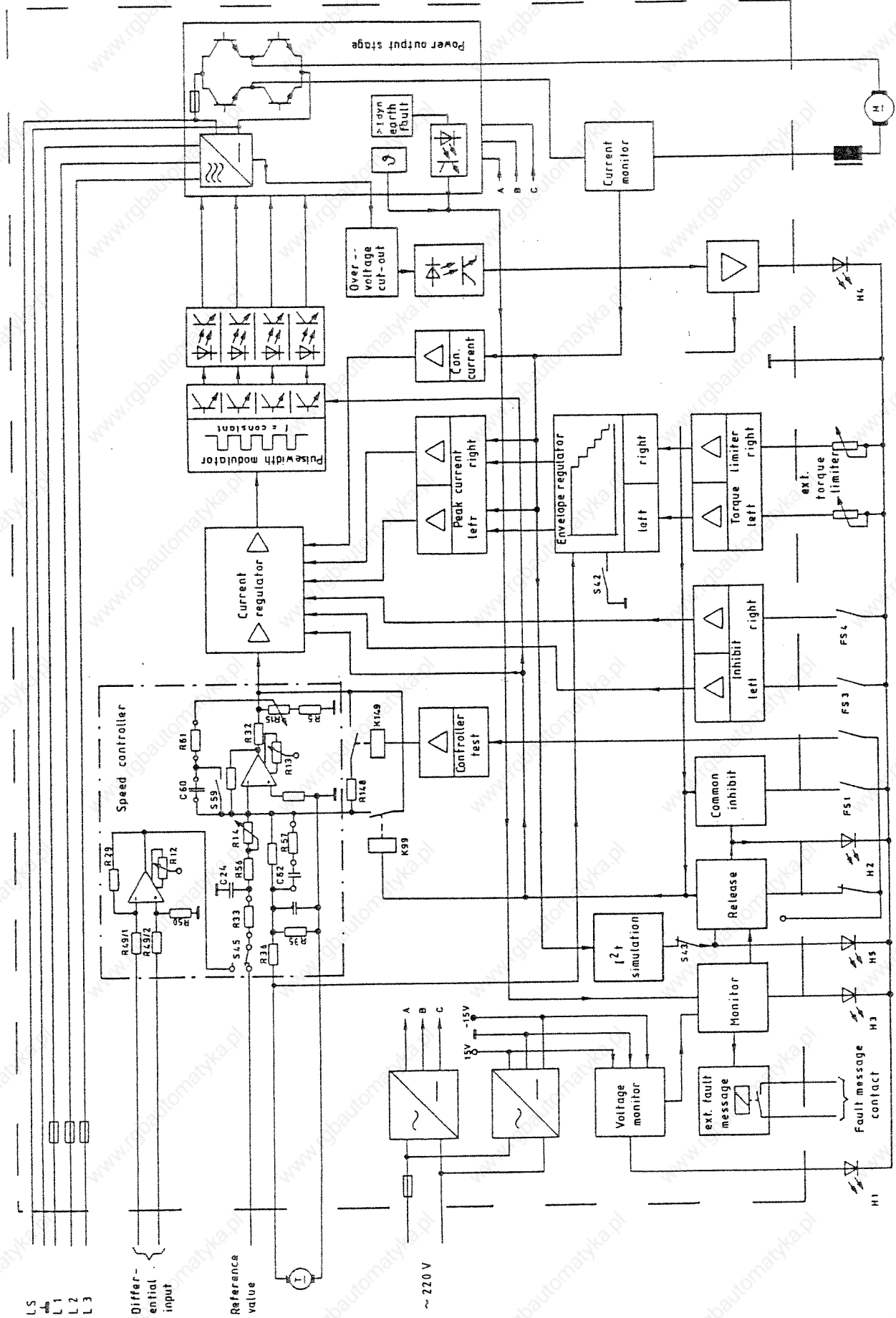

1.2.4 Manufacturer's designation

Example:

SVC 3 0 0 0 / X X V X X S X X

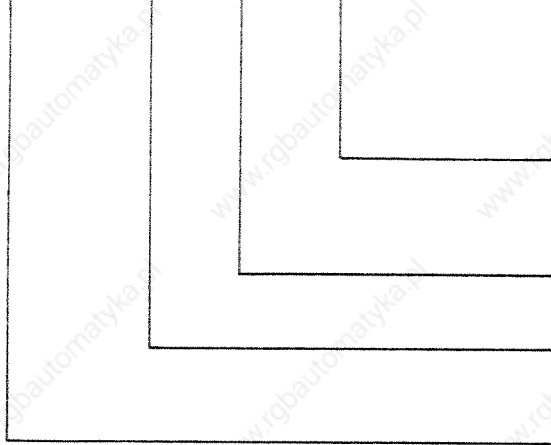

Equipment Serial No. also indicates latest technical state

Variant No. for customized equipment versions \*

Designation of constellation

Designation of the equipment-family or the output size of the standard-equipment

\* HAUSER balances known types of motor.

For instance: Standard balance V 10 for MC 23.

Supplementary documentation will be included if the model type differs from the standard designation.

1.2.5 Mechanical data

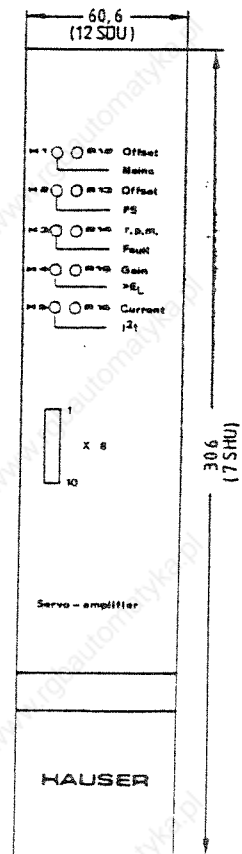
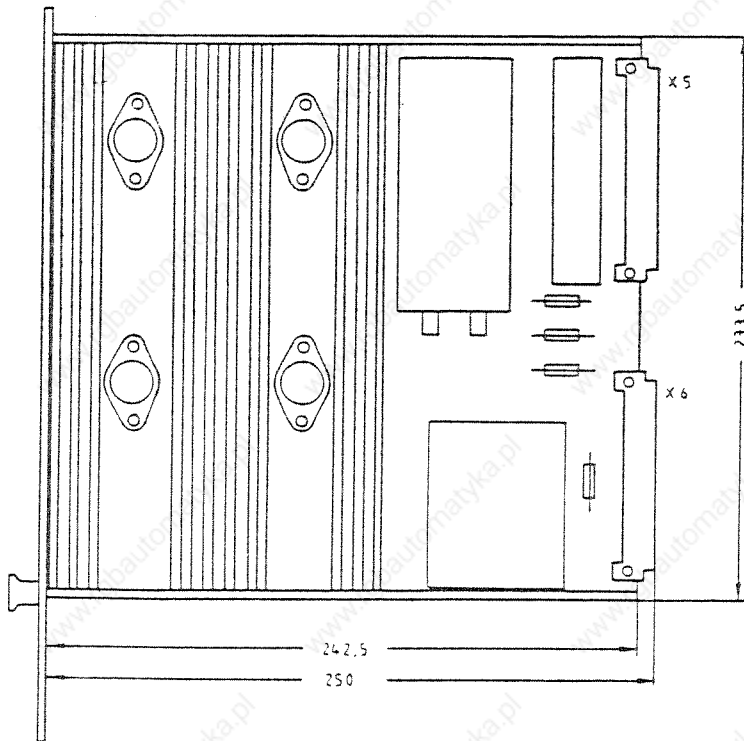

Weight approx. 3 kg, including carrierboard

03-EBM-RGG-SVC-4185 N1

03-BTA-RGG-SVC-2303 N2



### 1.3 Subrack

#### 1.3.1 Types of input

The carrierboard establishes the electrical link between the connection points and the servo-amplifier via two 32-pole VG male multipin connectors DIN 41612.

There are two types of connection:

- Terminal connection X 2 for wall mounting
- Plug-and-socket connectors X 1 and X 3 for plug-in module technology

#### Individual voltage supply:

An individual power supply source is advisable when different supply voltages are needed for the individual amplifiers. In this case each amplifier is separately served. The amplifier's intermediate circuit voltages must not be bridged.

#### Parallel voltage supply:

Parallel voltage supply via bus bars is only possible when the individual amplifiers require the same supply voltage. The intermediate circuit voltages of the amplifiers must not thereby be bridged. However, if one wishes to connect the intermediate circuit via bus bars so as to distribute the energy in the generator mode, then each amplifier must be supplied through a galvanically isolated power input.

#### Composite axis mode:

It is possible to combine different HAUSER servo-amplifiers in the subrack with the SVC 3000. The method of operation is as for individual voltage supply.

1.3.2 Mechanical data

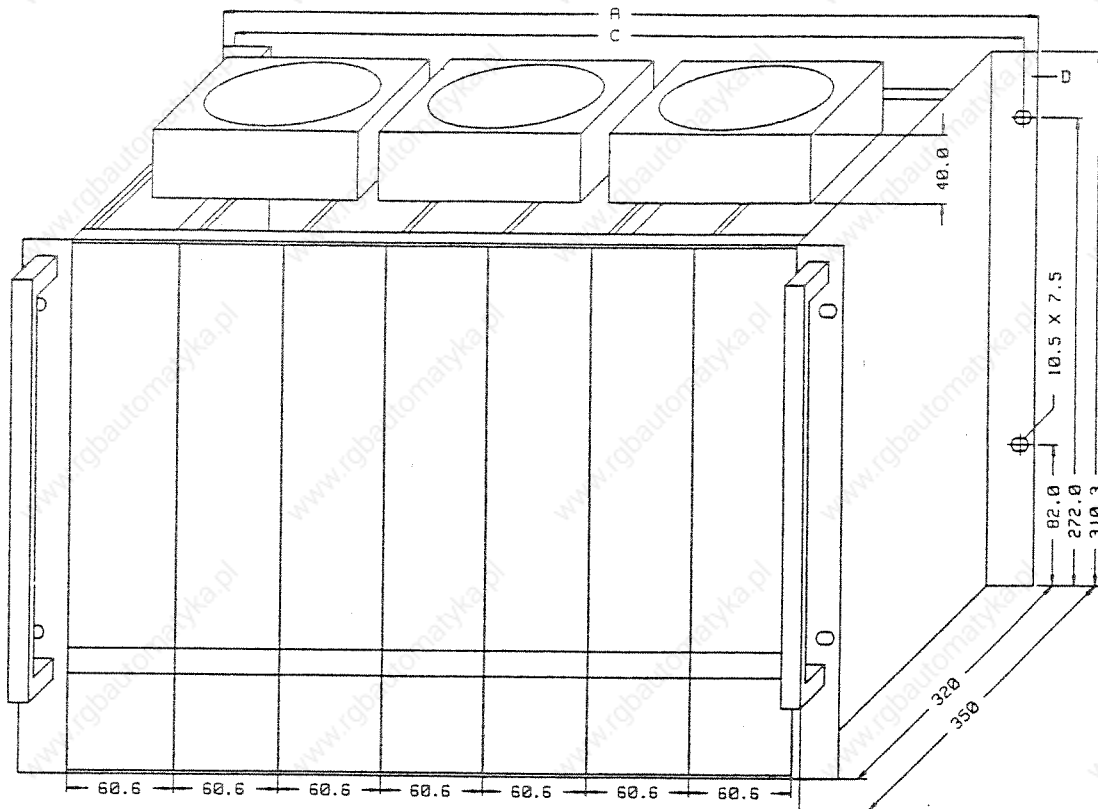

03-MBI-GEH-SVC-4006 N2

Dimension table (in mm)

Code letter and designation	up to 4 axes	19" - rack up to 7 axes
A Overall width	300	483
C	282	465
D Mounting bracket	on wall only	yes

With the plug-in module technique, the cooling fans are mounted on the underside of the subrack without increasing the dimensions.

1.4 External components

1.4.1 Three-phase transformer

Determining the parameters

Drive axis	Motor		Axis output VA	Auxiliary voltage output per Axis / VA
	Voltage V	current A		
1	83	6	498	100
2	83	14,4	1195,2	100
3	83	6	498	100
4	-	-	-	-
Total output			2191,2	300

The rated capacity of the transformer can be calculated as follows:

$p$  (transf.) = Sum of axis outputs  $\times$  1,25  $\times$  percentage duty cycle factor + sum of auxiliary voltage outputs

Example:

Assume that three motors are to be operated according to the above table.

The percentage duty cycle factor equals 0,7  $\times$  (percentage duty cycle factor according to Assoc. of German Elec. Eng. Spec. VDE 0530 Part 1)

$$2191,2 \text{ VA} \times 1,25 \times 0,7 + 300 = 2217,3 \text{ VA}$$

The choice therefore falls of Type DTS 025 with 2,5 kVA

Dimensions and weights of the three-phase transformer

as per Assoc. of Germ. Elec. Spec. VDE 0550

Triple-core transformer; Enclosure IP 00 - IP 20.

Suitable for use as isolating transformer.

Protective class I or II; insulation class T 40 / E.

Primary voltage 110 - 660 V

Secondary voltage 65 - 85 - 130 - 178 V

small base area

Type DTS S	Rated capacity in kVA	E(O2)/E(N2)	Efficiency in %
007	0,75	1,048	92
010	1,0	1,045	94
015	1,5	1,038	94
020	2,0	1,038	94
025	2,5	1,035	94
030	3,0	1,032	95
040	4,0	1,03	95
050	5,0	1,028	96
060	6,0	1,025	96
075	7,5	1,022	96
100	10,0	1,02	96
120	12,5	1,02	96

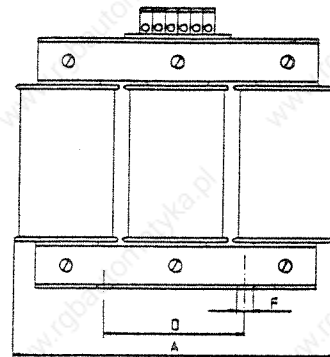
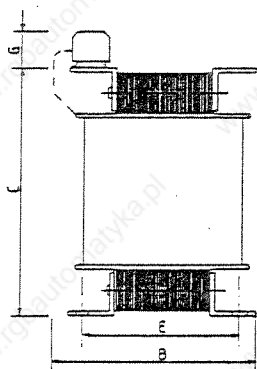

03-ABP-DTS-ABC-4858

Dimensions in mm

Type DTS S	A	B	C	D	E	F	G	Total weight in kg	Type of housing
007	204	101	176	110	81	7	50	14,5	F 91
010	240	87	206	125	67	7	50	16,0	F 126
015	240	107	206	125	87	9	50	21,0	F 126
020	240	118	206	125	98	9	50	28,0	F 126
025	300	103	256	170	79	11	50	32,0	F 126
030	300	103	256	170	79	11	50	38,0	F 126
040	300	128	256	170	104	11	50	46,0	F 126
050	335	124	286	190	96	11	50	51,0	F 140
060	335	157	286	190	129	11	50	62,0	F 140
075	360	151	306	200	123	11	50	75,0	AKL 140
100	360	167	306	200	139	11	50	85,0	AKL 140
120	420	183	356	250	143	16	50	115,0	AKL 140

low installed height

Type DTS S	Rated capacity in kVA	E(02)/E(N2)	Efficiency in %
007 L	0,75	1,048	92
010 L	1,0	1,045	94
015 L	1,5	1,038	94
020 L	2,0	1,038	94
025 L	2,5	1,035	94
030 L	3,0	1,032	95
040 L	4,0	1,03	95
050 L	5,0	1,028	96
060 L	6,0	1,025	96
075 L	7,5	1,022	96
100 L	10,0	1,02	96
120 L	12,5	1,02	96

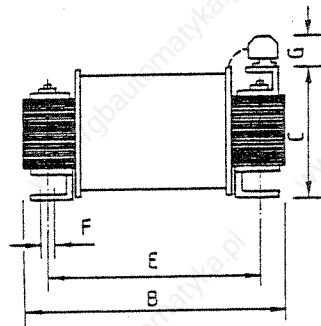
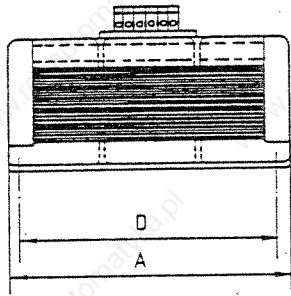

03-ABP-DTS-ABC-4857

Dimensions in mm

Type DTS S	A	B	C	D	E	F	G	Total weight in kg	Type of housing
007 L	254	176	102	228	135	7	50	14,5	G 91
010 L	290	206	90	258	160	9	50	16,0	G 91
015 L	290	206	112	258	160	9	50	21,0	G 91
020 L	290	206	122	258	160	9	50	28,0	G 91
025 L	330	256	121	298	200	9	50	32,0	G 126
030 L	330	256	121	298	200	9	50	38,0	G 126
040 L	330	256	149	298	200	9	50	46,0	G 126
050 L	360	286	134	322	225	9	50	51,0	G 140
060 L	360	286	168	322	225	9	50	62,0	G 140
075 L	394	306	158	358	245	9	50	75,0	on request
100 L	394	306	173	358	245	9	50	85,0	on request
120 L	452	356	187	408	285	11	50	115,0	on request

1.4.2 Smoothing choke

Smoothing choke ①	Rated current ②	Resistance	Inductivity	Dimensions in mm					Weight in kg
				3					
Type GDC	A	mOhm	mH	A	B	C	D	E	
100	15	60	3,4	94	92	105	65	63	2,5
200	15	70	4,7	112	105	123	84	73	4,2
400	25	15	2	112	105	123	84	73	4,0

- ① As per Assoc. of Germ. Elec. Eng. Spec. VDE 0550, Enlosure IP 00, Insulation Class T 40 / F.
- ② At ambient temperature + 25 degrees Celsius
- ③ Usable securing screw M 5

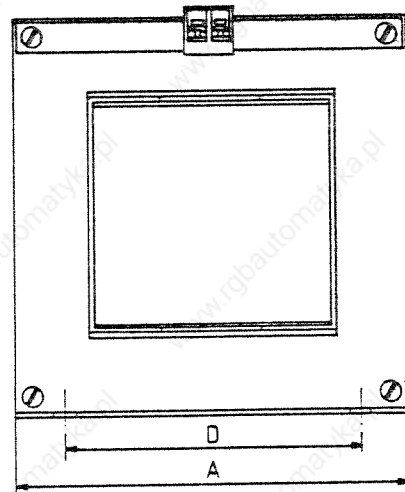
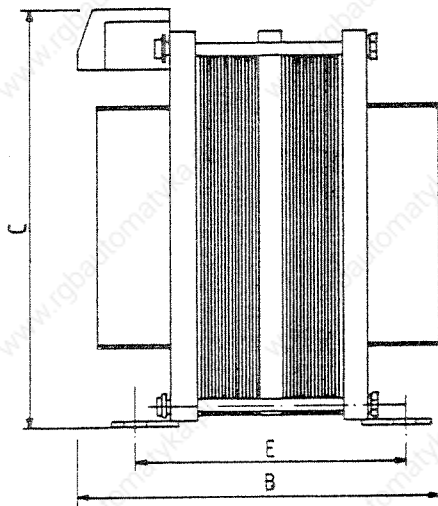

03-ABP-GDC-ABC-0080

### 1.4.3 Generator load module (GLM)

The GLM prevents the amplifier from going into fault status due to excessively high kinetic energy in the generator mode (braking). The maximum electrical energy which the individual amplifiers can accept depends upon the supply voltage applied. The following table shows this relationship:

$E_L / V$	65	85	130	178
$W_{kin} / WS$	52,3	49,5	40,7	28,9

If the kinetic energy exceeds this calculated value, the servo-amplifier will be inhibited with latching.

Connecting a generator load module to the intermediate circuit (supply voltage + LS and supply mass ) converts the excess energy into heat.

## 2. FUNCTIONAL DESCRIPTION OF THE SERVO - AMPLIFIER

### 2.1 General

#### 2.1.1 Design

The amplifier comprises a customer printed-circuit board, a galvanically isolated power output stage and a motor PC-board, which together make up one modular plug-in unit.

After removing the front panel, access can be gained to a motor board mounted on the customer board with the control and monitoring electronics; the motor board carries all the customer-specific parameters.

#### Example:

Standard motor board

PID and rotary speed balance, continuous current, pulse current and offset adjustment as well as speed (r.p.m.) controller, differential amplifier, characteristic curve of the envelope and an I(2)t simulator. The two latter can be brought on line with mini-switches.

Located on the back of the servo-amplifier module are two 32-pole VG multi-pin connectors, providing the electrical link to the carrierboard.

The front of the plug-in unit is closed by a front panel. From here one has access to the following parameters adjusters:

- Offset of the differential input
- Offset of the speed controller
- Rated r.p.m.
- Gain of the speed controller
- Continuous current

Five light-emitting diodes show the actual operating states, and simplify fault diagnosis:

- |                         |            |
|-------------------------|------------|
| - Mains                 | green LED  |
| - Inhibit               | yellow LED |
| - General fault message | red LED    |
| - Over-voltage monitor  | red LED    |
| - Fault I(2)t           | red LED    |

All important information to simplify fault isolation and commissioning is available on servicing socket X 8.

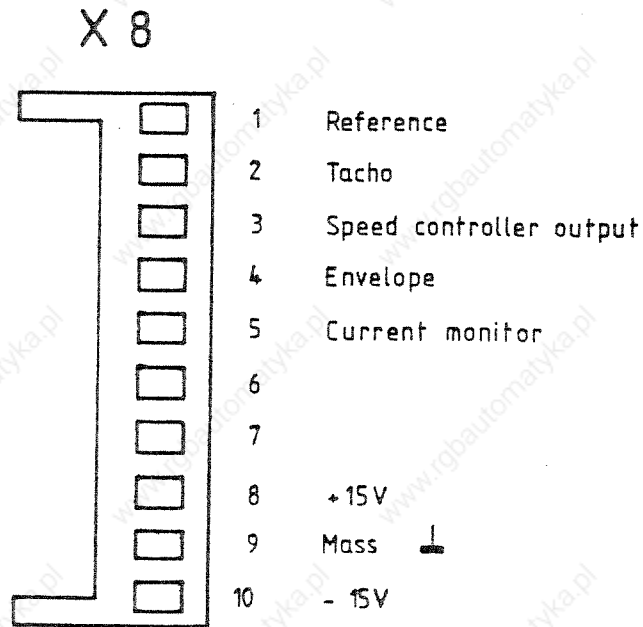

03-SBP-KDP-SVC-4187 N2



Exploded view of the equipment

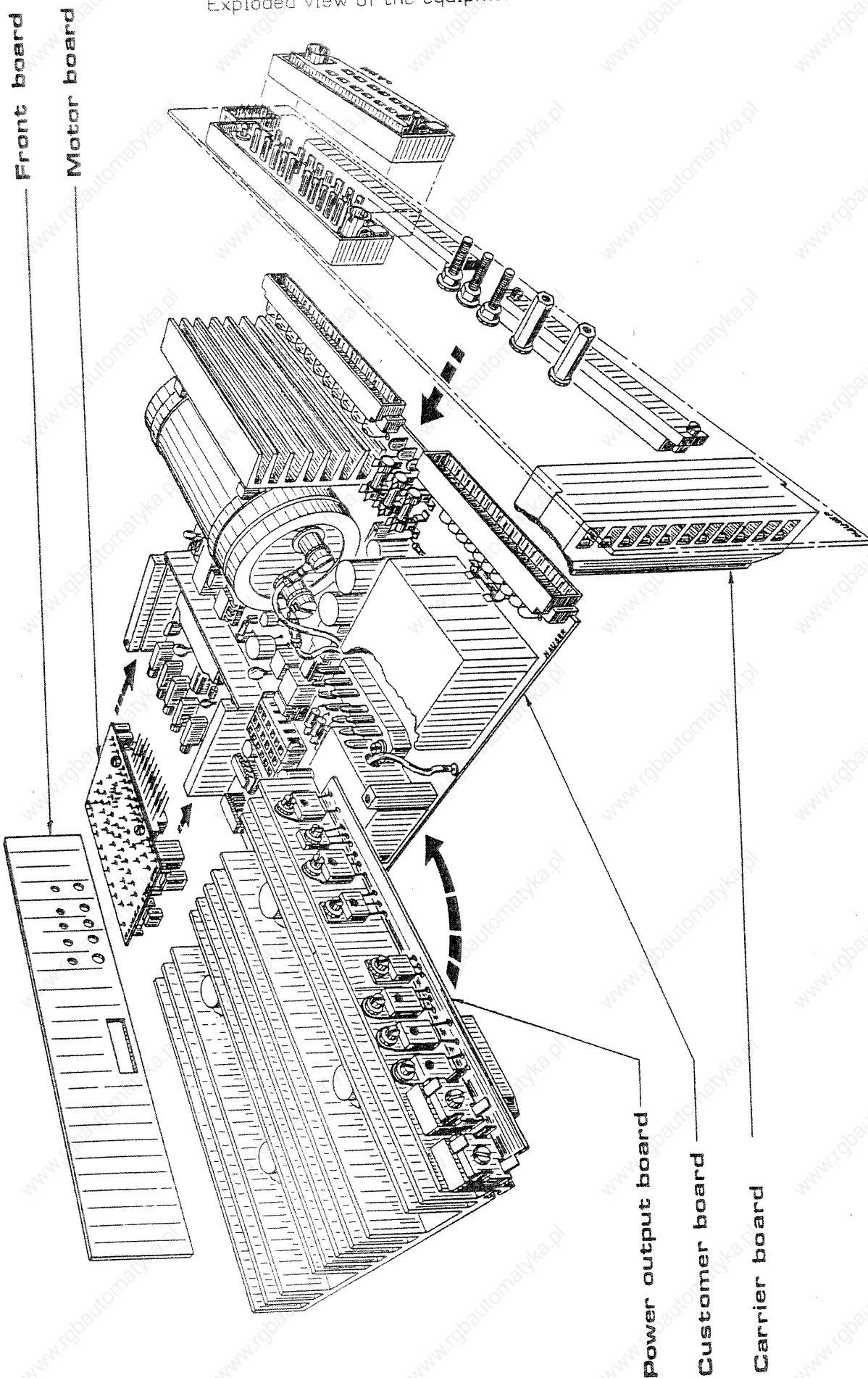

3-EXZ-RGG-SVC-4188 N1

### 2.1.2 Method of operation

The control structure can be seen from the block circuit diagram "DC drives" (page 3). The speed controller receives the desired r.p.m. reference voltage as an analogue value, which it compares with the actual value from the motor's tacho-generator and governs it so that the actual value equals the reference value. Backing the speed controller is the current regulator, which limits the system to the preset dynamic current. If the dynamic current is present for longer than 0,5 sec, the continuous current regulator will reduce the motor current to the continuous current preset for the equipment. The actual value of the motor current is detected without losses by a Hall module.

The analogue current regulator signal is converted by the pulse duration modulator (PDM) into a digital quantity. Any change in the analogue input quantity causes a change in the on and off time of the four activating signals. These activating signals pass via opto-couplers (to galvanically isolate the power output stage) to a constant-current regulating, self-monitoring drive IC, which boosts the square-wave signals and drives the high-voltage power transistors. If required, a choke in series with the motor serves to smooth the current. The motor is fed with a hybrid current made up of DC and AC components.

## 2.2 **Speed Controller**

### 2.2.1 Rotary speed reference value

The reference voltage of -10 V to 0 V to +10 V with direct mass connection can be provided

- a) via an external potentiometer
- b) as a separate-source voltage.

The input impedance depends upon the speed (r.p.m.) balance (see para. 2.2.4). In the standard circuitry the minimum input resistance is approx. 13 kOhms. The r.p.m. of the drive alters in proportion to the reference voltage, which can be measured on the "Reference value" servicing socket X 8/1. The direction of rotation is determined by the polarity: A positive reference voltage causes the motor to a righthand rotation as viewed onto the projecting end of the shaft, assuming that the motor and the tacho-generator are connected according to the connection diagram (drive side A of the motor, see para. 3.2). Offset adjustment is made with potentiometer R 13. Final trimming to rated r.p.m. is done with R 14.

### 2.2.2 Rotary speed reference value via differential input

The differential input allows the reference value to be preset using an outside voltage source without having a direct mass connection between the two systems. Offset adjustment is made with potentiometer R 12.

The speed balance stated in para 2.2.4 is maintained.

A positive reference voltage causes the motor to a lefthand rotation as viewed onto the projecting end of the shaft, when the motor and the tachogenerator are connected according to the connection diagram (drive side A of the motor).

#### Important:

The Dip-Fix-bridge S 45 must be reversed when using the differential input. This action takes reference value input 1 out of operation.

### 2.2.3 Rotary speed actual value (test point X 8/2)

As an actual value transducer we recommend a DC tachogenerator supplying a low-ripple voltage (high number of pole-pairs), e.g., Axometer tachogenerator type F 12 T. This tachogenerator is supplied by Axem Motors already mounted onto the motor shaft. The link eliminates torsional instabilities between the motor and the tachogenerator. Tachogenerators with high ripple considerably restrict the dynamic of the drive.

### 2.2.4 Rotary speed adjustment

Speed matching (i.e., the relationship between the actual value and reference value voltages and thus the coordination of the r.p.m. to the reference voltage) can be adjusted through a partial range of approx. 30 % by potentiometer R 14. Balancing for the maximum r.p.m. is done on the fixed-value resistor R 56, with potentiometer R 14 set to maximum r.p.m. (righthand stop of R 14 = maximum r.p.m.).

Calculation of R 56:

$$R_{56} = \frac{30 \text{ kOhm} \cdot E_S}{K_{emf} \cdot N} - R_{33} = \dots \text{ kOhm}$$

R 56 : Balancing resistance (kOhm)

N : Max. speed (1.000 r.p.m.)

$E_S$  : Max. reference voltage (V)

$K_{emf}$  : Tacho voltage constant

R 14 : Standard = 10 kOhm

R 33 : Standard = 3,32 kOhm

As standard, R 56 is balanced for the +/- 10 V reference voltage at the rated r.p.m. of the motor/tacho-generator combination specified at the time of ordering. Standard input impedance of the actual value input is approximately 10 kOhm.

The speed controller circuit can be seen from the circuit diagram of motor board MOP 2/00.

### 2.2.5 Offset adjustment

Offset adjustment of the speed regulator is carried out on potentiometer R 13, whereby the reference voltage should be 0 V if at all possible. The offset adjustment is no longer acceptable with residual voltages greater than approx. +/- 5 mV.

For precise setting, a measuring instrument can be used to adjust either the tacho voltage or the voltage on the motor terminals to 0 Volts. Motor and tacho must remain connected whilst the measurement is being taken.

An additional offset adjustment can be made with potentiometer R 12, if the reference value is connected through the differential input.

### 2.2.6 Servo Control action

The circuiting of operation amplifier N 30 determines the control action of the equipment. Amongst other things, the control action describes the drive run-up to an r.p.m. defined by the reference voltage. The running-up action depends on the controlled system and must be balanced to it if necessary. With a 1 to 5 factor external moment of inertia on the motor, no new adjustment is needed, or adaptation can be achieved with potentiometer R 15 "Gain", as the case may be.

Potentiometer	R 15	:	P-component (gain)
Resistor	R 61	:	P-component (gain)
Capacitor	C 60	:	I-component
Capacitor	C 62	:	D-component
Resistor	R 57	:	D-component

The positions of these components can be seen from the component diagram for the motor board MOP 2/00.

### 2.2.7 Hunting

When adjusting the regulator action, or when putting into operation for the first time there is the risk of continuous control hunting if the gain is set too high. If so, the gain must be reduced with R 15 or (and) R 61 so as to avoid thermally overloading the motor.

## 2.3 Current limiters

### 2.3.1 Continuous current

The continuous current limiter works in the event of mechanical overloading of the drive, after the peak current time has expired (dynamic current limitation), and if the motor terminals are short-circuited.

When the current limiter is in operation, the r.p.m. depends upon the overload. The current limiter is adjusted in the factory to the continuous current specified for the amplifier. If necessary, it can be reduced with potentiometer R 15 "Current".

If the type of motor is known at the time the equipment is despatched, the continuous current limiter will be set to the rated motor current.

A voltage proportional to the motor current can be measured on service socket X 8/5. Conversion factor 1 V = 10 A.

### 2.3.2 Dynamic current limiter

The dynamic current limiter allows the drive an excessive motor current of max. 30 A for approx. 0,5 sec. It is known as the peak current.

The effect is more rapid acceleration and shorter braking period. It is time-limited so as to protect the motor against thermal overloading. When the peak current period has expired, the current reduces down to the max. 15 A set as the continuous current.

After prior consultation with the maker, the peak current period may be altered.

### 2.3.3 Torque reduction

It is possible to externally adjust the peak current by connecting a voltage of between 0 to 10 V to FS 3 and FS 4 respectively, or with a 10 kOhm potentiometer to mass. Such adjustment reduces the motor torque. The torque reduction can be made independently for righthand- (on FS 4) and lefthand rotation (on FS 3).

Motor current - voltage diagram

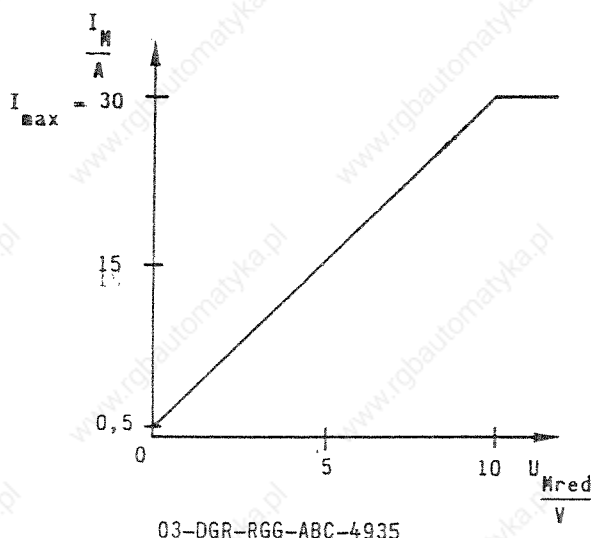

$I_M$  = Motor current

$I_{max}$  = Max. peak current

$E_{Mred}$  = Voltage on FS 3 and FS 4 respectively

03-DGR-RGG-ABC-4935

## 2.4 Protective devices

Various protective devices monitor functions vital to operation. In the event of a fault, the servo-amplifier is "inhibited", i.e., supply voltage is electrically isolated from the drive. Selection of the fault and operating status indicators allows the type of fault to be recognized, whereby a difference is made between inhibiting with or without self-latching.

Summarizing plan

Type of fault	LED Mains H1	LED FS H2	LED Fault H3	LED Fault H4	LED Fault H5	Effect of inhibiting
Supply voltage excessive $\geq 350$ V	X	X		X		with latch
Auxiliary voltage too low			X			without latch
Short in + 15 V			X			without latch
Short in - 15 V			X			without latch
Thermal overload in putput stage	X		X			with latch
Earth or short fault in output stage	X		X			with latch
I(2)t limit of motor reached	X	X			X	with latch
Motor PC-board not plugged in	X	X				

All faults listed in the summary are detected by the monitor. The "inhibiting without self-latch" function is automatically lifted when the fault is rectified, whereas in the case of "inhibiting with self-latch" it is necessary to switch the mains voltage 'off' and 'on' again once after rectification (mains reset).

A switch-on delay of approx. 0,5 - 0,8 sec. ensures a proper state of operation.

During this period the yellow "FS" LED illuminates.

#### 2.4.1 Auxiliary voltage monitor

If the auxiliary voltage falls below a lower limiting value of approx. +/- 13,5 V, the amplifier reports a fault without latch. This is shown by red fault LED "H 3", whereby the green mains supply LED "H 1" extinguishes at the same time. It is possible for the red fault LED "H 3" to illuminate in response to large external load variations or drops in the mains voltage. A 100 kHz ripple voltage can be measured on service socket X 8/8.9.10.

There will be no optical signal if a fuse blows or if both auxiliary voltages are short-circuited. An error message can nevertheless result by evaluating the fault message contact.

#### 2.4.2 Over-voltage monitor ( $> E_L$ )

The amplifier output stage will be inhibited in the event of a voltage increase attributable to feed-back energy from the generator (braking). The over-voltage shut-down function remains latched. The shut-down threshold is set in the factory to 350 V.

Indication is provided by illumination of the red LED "H 4". The latch is lifted by switching the mains voltage 'off' and 'on' again once (mains reset).

If this fault - whereby the kinetic feed-back is too great - occurs several times, it will be necessary to connect a generator load switching module (GLM) to the DC intermediate circuit at + LS (supply voltage) and supply mass. In this way the excess energy will be converted into heat over a ballast resistor (see para. 1.4.3).



#### 2.4.3 Thermal monitoring of the power output stage

In order to protect the power output stage from overheating, a thermocouple is mounted on the heat dissipator. If the temperature exceeds the maximum value of approx. 85 degrees Celsius the amplifier will be inhibited with latch.

Indication is provided by the red fault LED "H 3". The servo-amplifier can be brought back on line by switching the mains voltage "off" and "on" again once (mains reset), but not before the heat dissipator has cooled down. Adequate provision must then be made for ventilation. A cooling fan must be connected for a continuous current of 8 A and above.

#### 2.4.4 Short circuit, mass and earth fault monitoring ( $>I_{dyn}$ )

This monitoring circuit protects the power output stage against a short-circuit on the output terminals of the unit without motor choke, as well as in the event of mass and earth faults in the motor (only with earthed intermediate circuit voltage).

The monitored parameter is the output current. As soon as this exceeds the permitted dynamic current the servo-amplifier is inhibited with latch.

Indication is provided by illumination of the red LED "H 3". The latch is lifted by switching the mains voltage 'off' and 'on' again once (mains reset).

#### 2.4.5 $I(2)t$ simulation

This circuit prevents destruction of the motor due to thermal overloading. Where variable load cycles are involved, the critical parameters are the dynamic requirements of the motor, the relative percentage duty time and the magnitude of the load surge. The motor's power dissipation is limited by the max. permitted rotor temperature, which is a function of the square of the motor current. The circuit electronically simulates the thermal conditions in the motor, the time constants being adapted to the motor concerned. This takes into account the heat transfer from rotor disc to housing, and housing to ambient surroundings when the motor is at a standstill. On reaching the critical temperature (approx. 90 % of the motor's final temperature) the amplifier is inhibited with latch. Indication is provided by the red fault LED "H 5".

This circuit is primarily suitable for motors with small electrical time constants. For example: Disk rotor motors

Block schematic circuit

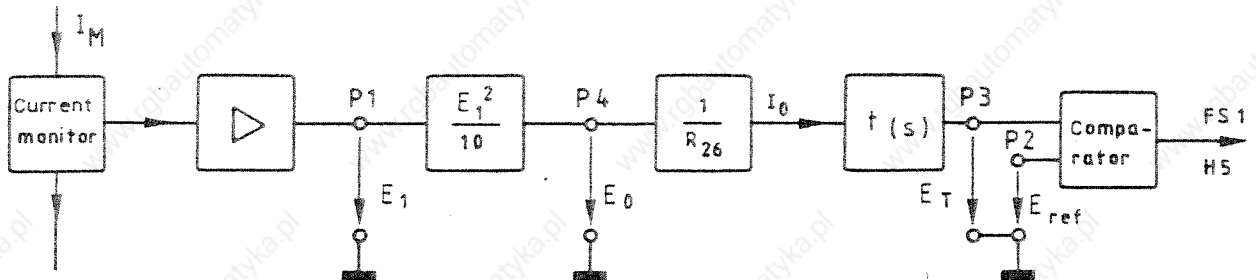

03-BSB-RGG-ABC-4936

The  $I(2)t$  simulation circuit can be rendered inoperative by changing over the mini-switch S 43 on the motor board.

#### 2.4.6 Envelope regulator

The envelope regulator limits the motor current in relation to the r.p.m., thereby protecting the motor against impermissible loading.

It is employed when using motors with speed-dependent commutator limits when exploiting the peak torque, e.g., Hytork motors.

A check can be made on the servicing socket X 8/5 = current monitor to determine whether and how the envelope regulator is in operation (1 V = 10 A).

If the envelope regulator is not to be used, mini-switch S 42 on the motor-board must be closed.

#### 2.4.7 Fault message relay

The fault message relay reacts to all faults as per para. 2.4, with the exception of  $I(2)t$  and  $> E_L$ .

Its floating-potential contact can be used for external evaluation if required. This contact is always circuited as a normally-closed device (line-continuity logic).

(Contact loading: 48 V, 0.5 A, 10 W)

## 2.5 Inhibiting inputs

Closing the external control contact electrically isolates the supply voltage from the drive. The drives slows down to a standstill without being braked. An applied torque load can no longer be held by the drive.

The connection points can be seen from the connection plan.

### 2.5.1 Inhibit input "FS 1"

Both directions of rotation are "inhibited" in common by one contact to mass.

The inhibiting function is effective for the duration of the signal only.

A yellow light-emitting diode H 2 "FS" shows this state. When the inhibit function is operative the controller is blocked; this arrangement avoids uncontrolled movement by the motor when the inhibit is lifted.

The following drive arrangements are possible when inhibiting with signal line:

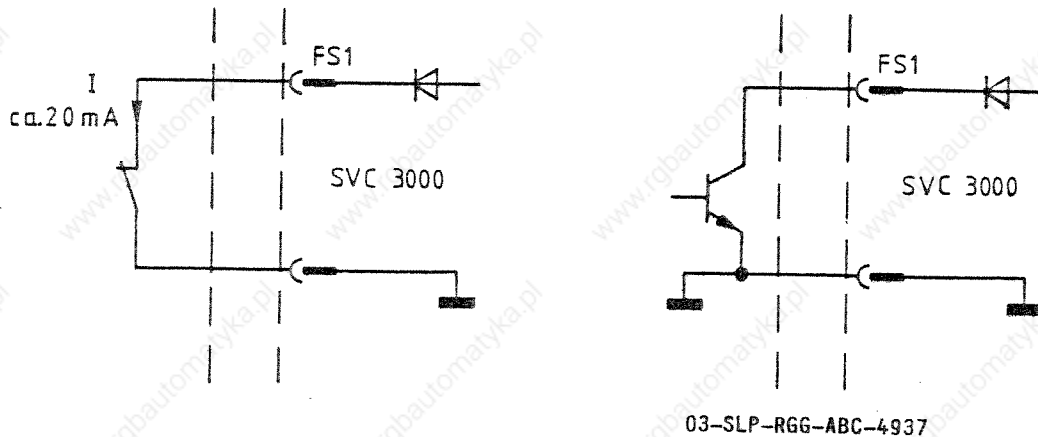

### 2.5.2 Inhibit input "FS 3"

A contact to mass inhibits only that direction of motion corresponding to a negative reference value. When a positive reference value is set, the motor rotates although without any braking action. The inhibiting action is only effective for the duration of the signal. This inhibit is not indicated by light-emitting diodes.

### 2.5.3 Inhibit input "FS 4"

A contact to mass inhibits only that direction of motion corresponding to a positive reference value. When a negative reference value is set, the motor rotates although without any braking action. The inhibiting action is only effective for the duration of the signal. This inhibit is not indicated by light-emitting diodes.

Note on paras. 2.3.3, 2.5.2 and 2.5.3:

In the actived state the motor is subject to a residual torque, which is calculated from the residual motor current and the torque constant  $K_T$  of the motor. The residual motor current  $\leq 500$  mA.

### 2.5.4 Release

The "Release" is provided via the bus connector X 4. This input can be used as a wire-breakage-safe inhibit, or as a signal input for higher order positioning controllers. An applied torque load can no longer be held by the drive.

Signal level: 2 to 15 V.

Input impedance: approx. 10 kOhm.

A yellow light-emitting diode H 2 "FS" shows this state.

Important:

If the input is not required, switch S 21 on the carrier-board must be closed.

## 2.6 Other connections

### 2.6.1 Controller test

This signal input fed via bus connector X 4 allows a proportional gain to be specified for the speed controller. The PI action of the speed controller is thereby suppressed, so allowing the drive to be controlled by the r.p.m.. For example, allocation check on the encoder and tacho signals.

There is no indication in this state. Signal level: 2 to 15 V. Input impedance: approx. 2 kOhms.

### 3. PUTTING INTO OPERATION

#### 3.1 Connection instructions

The following instructions must be observed in order to ensure faultless operation of the drive system:

1. The motor supply lead must be a three-core screened cable (2 cores for the motor voltage, 1 core for the PE conductor).

If single-core wires are used, they must be twisted. Under all circumstances the motor supply lead must be routed well separated from the tacho, reference value and incremental encoder lines. If this is not possible, an improvement can be obtained by using magnetically screened cable.

2. The tacho-, reference value- and incremental encoder-signals must be carried in the screened cable. The screen of the reference value and incremental encoder lead must be connected at the reference value encoder end (NC control), whereas the tacho lead screen must be connected at the controller end.
3. Non-fused earth conductor connection for system components (PE connections). All non-fused earth conductor connections must be led to a common star point and connected to the factory network protective earth (PE) conductor.
4. If the equipment is wall mounted, the screen on the tacho lead must be grounded to the safety earth (housing).

System grounding:

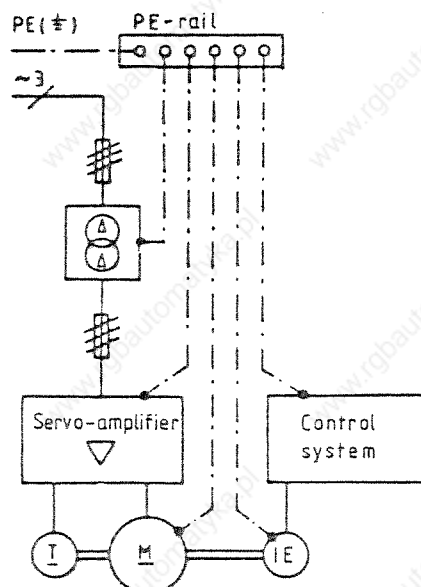

03-DGR-RGG-SVC-4862

03-BTA-RGG-SVC-2303 N2

### 3.2 Direction of rotation

In order to precisely predetermine the direction of rotation in a speed control system using a tacho-generator as the actual value encoder, proceed as follows:

1. Check the direction in which the drive motor rotates before connecting to the amplifier.

If the motor turns clockwise (as viewed onto the drive side A), a positive motor voltage must be present with the specified polarity (instrument needle deflects to the right).

2. Check the polarity of the tacho-generator before connecting to the amplifier.

If the tacho-generator turns clockwise a positive tacho voltage must be present (instrument needle deflects to the right).

3. If the requirements of paras. 1 and 2 above are met, the equipment is connected up according to the connection diagram.

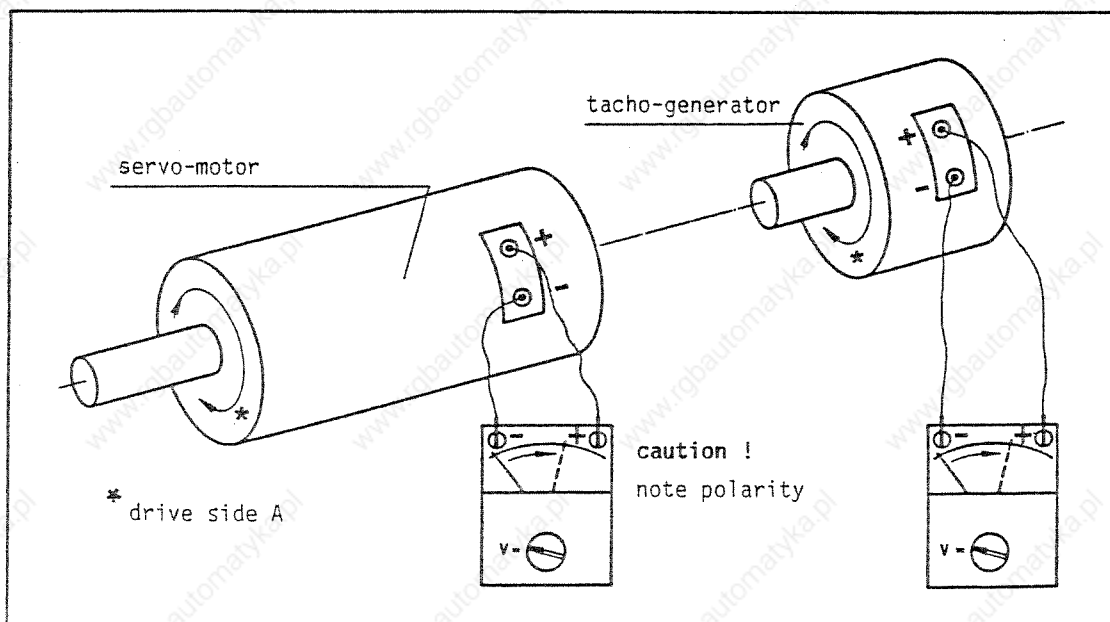

03-DGR-RGG-ABC-4863

### 3.3 Commissioning instructions

- Visually inspect the equipment for signs of damage.
- Check that plug-in PC-boards are firmly located.
- Connect primary-side of the mains transformer, and measure the secondary voltage.
- Fully wire up the equipment according to the connection diagram.

The following items must be connected:

- |                      |                                       |
|----------------------|---------------------------------------|
| a) Mains transformer | Connection data, see para. 1.4.1      |
| b) Fuses             | Connection data, see para. 4.         |
| c) Motor             | Direction of rotation, see para. 3.2. |
| d) Tacho             | Direction of rotation, see para. 3.2. |
| e) Choke             | Connection data, see para. 1.4.2.     |
| f) Reference value   | initially remains free                |

#### Notes:

The inhibit inputs must not be connected for commissioning, and must therefore remain free.

- Motor lead: Either twisted or in a 3-core cable (P, N, PE) routed for separately from the signal leads, since these carry square-wave voltages with steep pulse flanks.
- Tacho lead: Must always be screened. As shown in the connection plan, the screen must be connected at the equipment end.
- Reference value lead: Must always be screened. The screen must be connected at the reference value encoder end.
- Control leads must be laid in the same way as the tacho leads.
- Switch on the mains power supply.
- The motor must be stationary with torque applied, or may turn only very slowly.
- If the r.p.m. are high, the polarity of the motor or of the tacho connection must be changed (occurs because the tacho or motor has not been connected with the polarity given in the connection plan).
- Feed the reference value (tapped off of the potentiometer or external voltage source) to the reference value input.
- The motor should rotate according to the specified reference voltage (allocation, see paras. 2.2.1, 2.2.2).

- If the r.p.m. can be regulated by the reference value, but the polarity allocation of the reference voltage does not cause rotation in the desired direction, then the polarity of the tacho and the motor must be altered.
- If the motor fails to start after being switched on, check the following:
  - a) Is mains voltage fed to the mains transformer?
  - b) Does the fault lamp illuminate?  
If it does, refer to paras. 2.4 and 3.3.1 in the Operating Instructions.
  - c) Does the motor vibrate heavily? (see para. 2.2.7)
- The following adjustment jobs can be necessary:
  - a) Offset balance on R 13 (see para. 2.2.5)
  - b) r.p.m. adjustment on R 14 (see para. 2.2.4)
  - c) Servo-Control action on R 15 (see para. 2.2.6)
  - d) Continuous current reduction on R 16 (see para. 2.3.1)

### 3.3.1 Trouble shooting

Operating lamps illuminated	Cause of fault / Remedy
H1, H2	<ul style="list-style-type: none"> <li>- Motor board must be plugged in!</li> <li>- Inhibit contact "FS 1" not properly occupied!</li> <li>- Dip-Fix bridge S 21 on carrierboard closed <u>or</u> a voltage between 2 V and 15 V present when using bus input plug X 4/5 release</li> </ul>
H3	<ul style="list-style-type: none"> <li>- Mains voltage too low (220 V + 10 % / - 15 %)</li> <li>- +/- 15 V auxiliary voltage excessively loaded, or auxiliary voltage shorted / disconnect external loads (see para. 1.2.2)</li> </ul>
H1, H3	<ul style="list-style-type: none"> <li>- Thermal overload on output stage / ensure proper ventilation. Effective current too high / other cycle</li> <li>- Motor short-circuited, or earth fault in grounded intermediate circuit voltage / check motor</li> <li>- Cross / check the motor and choke leads</li> <li>- Check fuses F 1, F 2, F 3 (10 AM) and F 4, F 5, F 6 external) and F 165 (20 AM)</li> </ul>
H1, H2, H4	<ul style="list-style-type: none"> <li>- see under para. 2.4.2</li> </ul>
H1, H2, H5	<ul style="list-style-type: none"> <li>- see under para. 2.4.5</li> </ul>
no LED	<ul style="list-style-type: none"> <li>- Proper connection configuration / refer to connection diagram Section 4</li> <li>- Mains voltage connected / re-measure</li> <li>- Check fuses F 7 (external) and F 251 on the customer board</li> <li>- Both auxiliary voltages short-circuited / re-measure +/- 15 V on service socket X 8</li> </ul>



4. CONNECTION DIAGRAM (fuses)

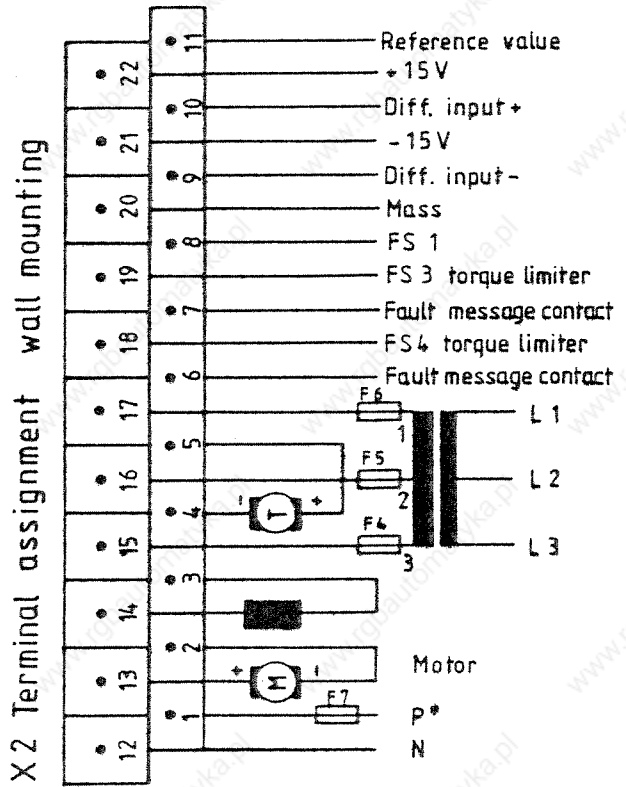
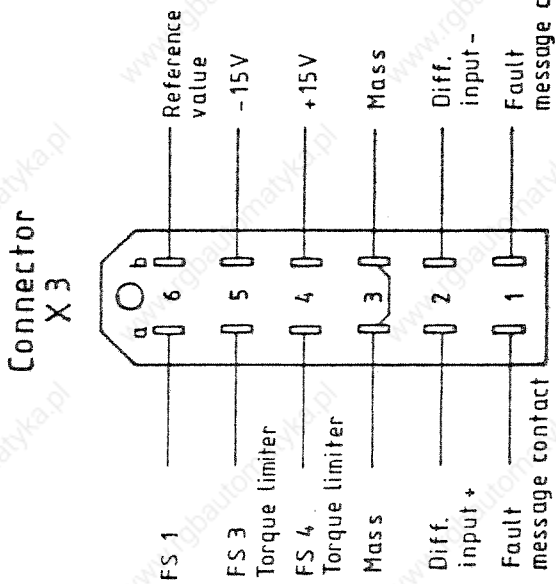
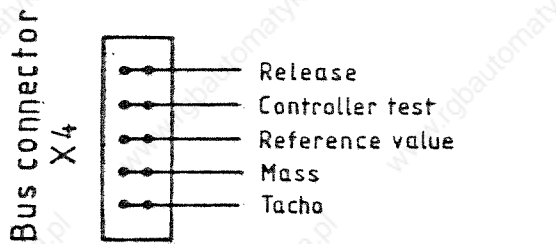
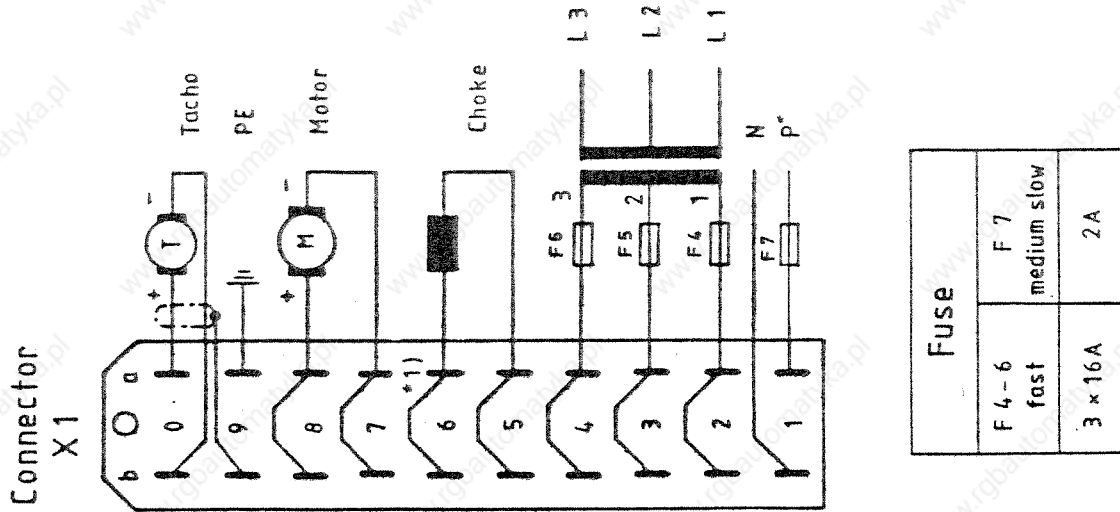

\* 1) Solder bridge to connector plug

\* Standard connection voltage 220V AC

03-ASP-RGG-SVC-4189 N4

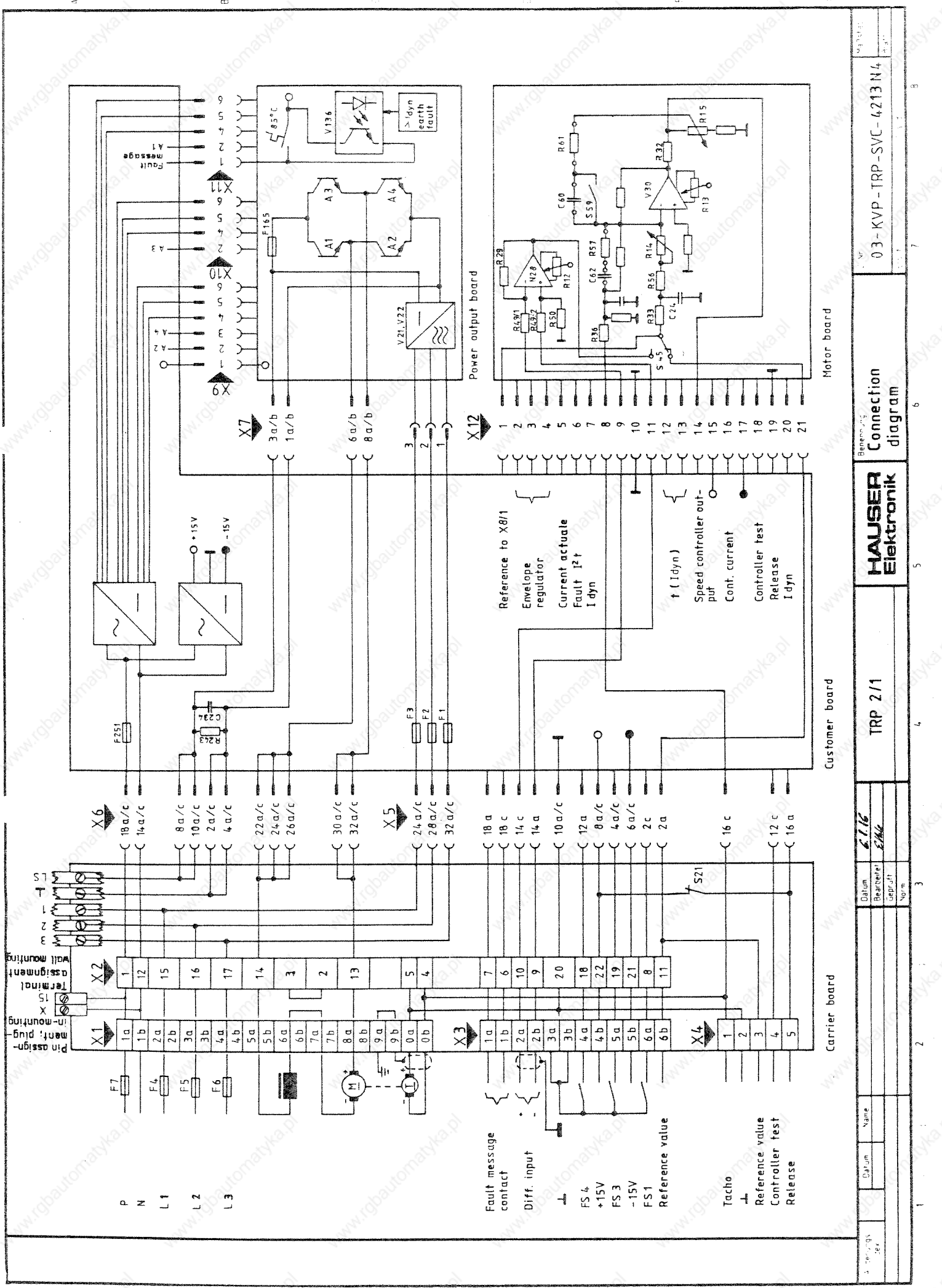

3 - drawings per		Datum		Name		TRP 2/1		HAUSER Elektronik		Reference		03-KVP-TRP-SVC-4213 N4	
1		6.1.16		E/M		4		5		6		7	
2		3		3		4		5		6		7	
3		3		3		4		5		6		7	
4		3		3		4		5		6		7	
5		3		3		4		5		6		7	
6		3		3		4		5		6		7	
7		3		3		4		5		6		7	
8		3		3		4		5		6		7	
9		3		3		4		5		6		7	
10		3		3		4		5		6		7	
11		3		3		4		5		6		7	
12		3		3		4		5		6		7	
13		3		3		4		5		6		7	
14		3		3		4		5		6		7	
15		3		3		4		5		6		7	
16		3		3		4		5		6		7	
17		3		3		4		5		6		7	
18		3		3		4		5		6		7	
19		3		3		4		5		6		7	
20		3		3		4		5		6		7	
21		3		3		4		5		6		7	
22		3		3		4		5		6		7	
23		3		3		4		5		6		7	
24		3		3		4		5		6		7	
25		3		3		4		5		6		7	
26		3		3		4		5		6		7	
27		3		3		4		5		6		7	
28		3		3		4		5		6		7	
29		3		3		4		5		6		7	
30		3		3		4		5		6		7	
31		3		3		4		5		6		7	
32		3		3		4		5		6		7	
33		3		3		4		5		6		7	
34		3		3		4		5		6		7	
35		3		3		4		5		6		7	
36		3		3		4		5		6		7	
37		3		3		4		5		6		7	
38		3		3		4		5		6		7	
39		3		3		4		5		6		7	
40		3		3		4		5		6		7	
41		3		3		4		5		6		7	
42		3		3		4		5		6		7	
43		3		3		4		5		6		7	
44		3		3		4		5		6		7	
45		3		3		4		5		6		7	
46		3		3		4		5		6		7	
47		3		3		4		5		6		7	
48		3		3		4		5		6		7	
49		3		3		4		5		6		7	
50		3		3		4		5		6		7	

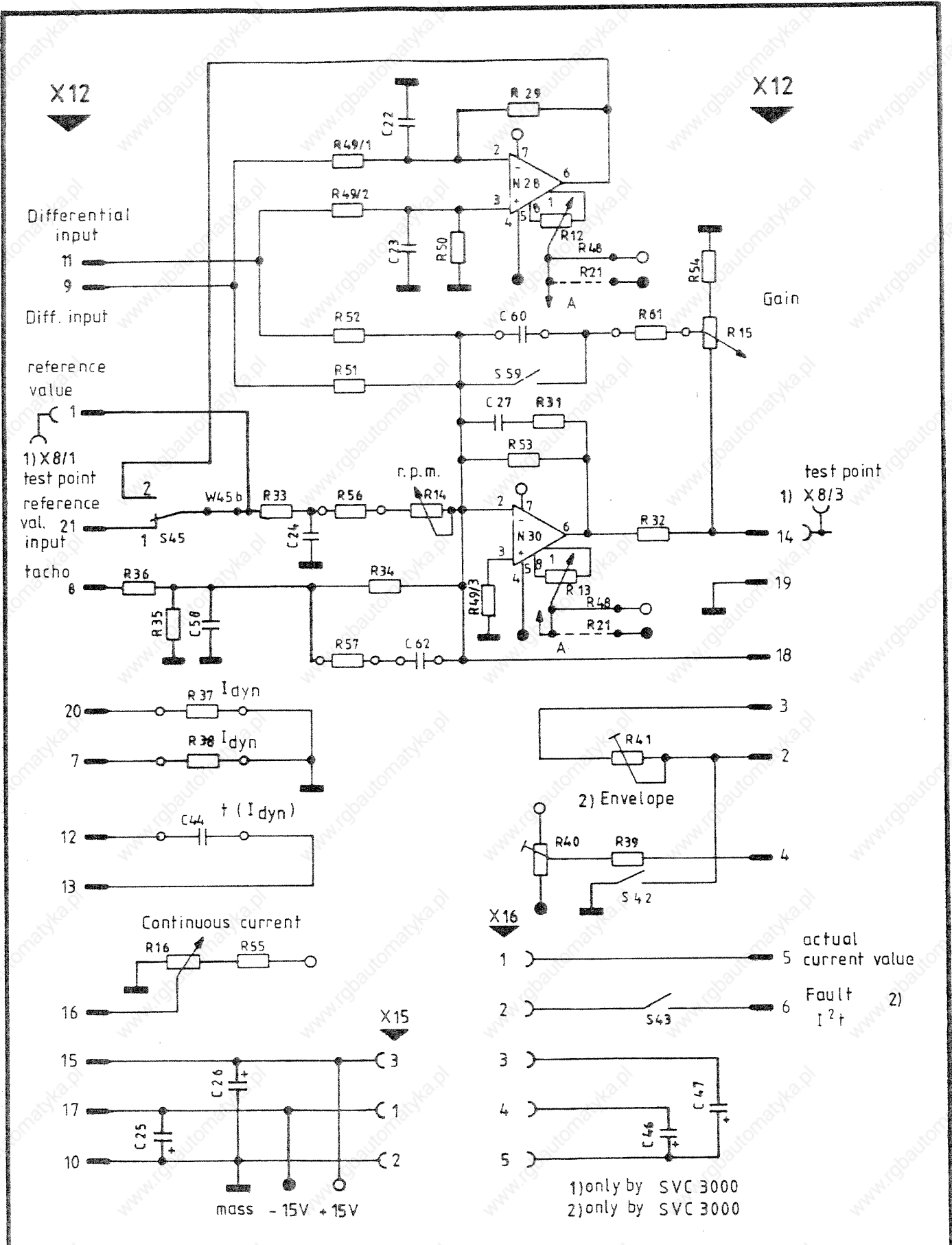

Änderungs- index	Datum	Name	Bearb.	Datum	Name	Benennung
	6.10.81	O. Hübner				
Meßpunkte eingetragen			Norm			
HAUSER Elektronik			Z Nr	03 - SLP - MOP - ABC - 4225 N4		
			Ers f	Ers d		
			Maßstab	Blatt ( )		

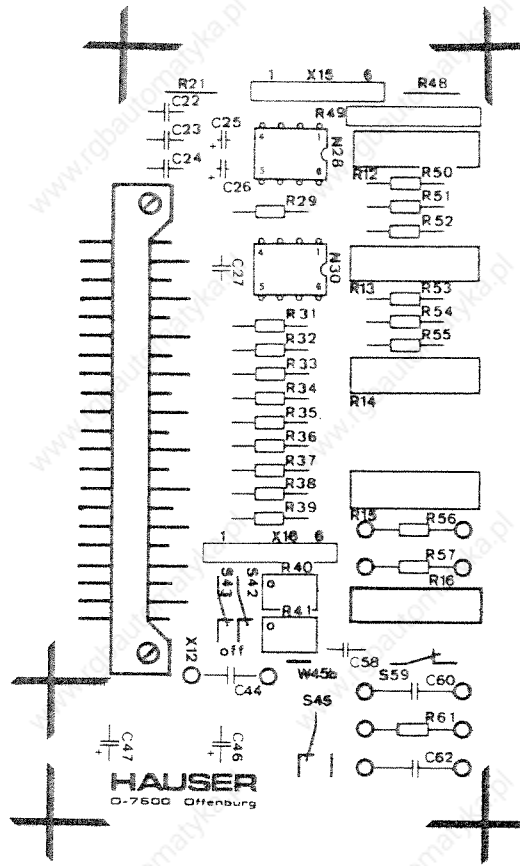

Anderungs- index	Datum	Name	Datum	Name	Benennung	
			Bearb	10.10.86 ERL	Equipment diagram Motor board	
			Gepr			
			Norm			
<b>HAUSER Elektronik</b>					Z Nr	03-BST-MOP-ABC-4226 N6
					Ers f	
					Maßstab	
					Blatt ( )	

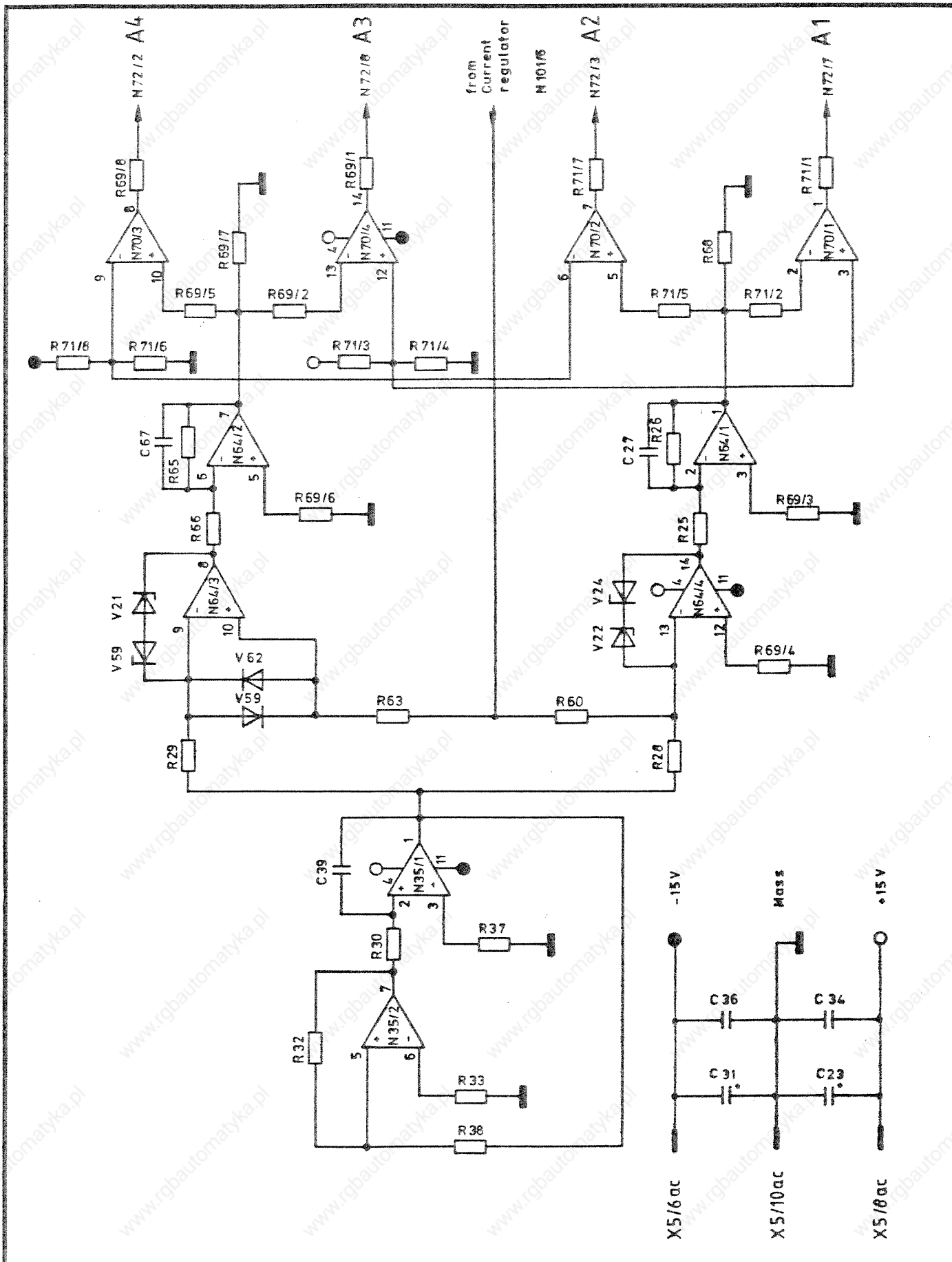

Anderungs-index	Datum	Name	Datum	Name	Benennung	
			6.8.86	CMC	Current diagram	
			Gepr		KDP 2/1	
			Norm			
<b>HAUSER</b> Elektronik					Z Nr	Maßstab
					03-SLP-KDP-SVC-4215 N2	Blatt 1/1
Ers f					Ers d	

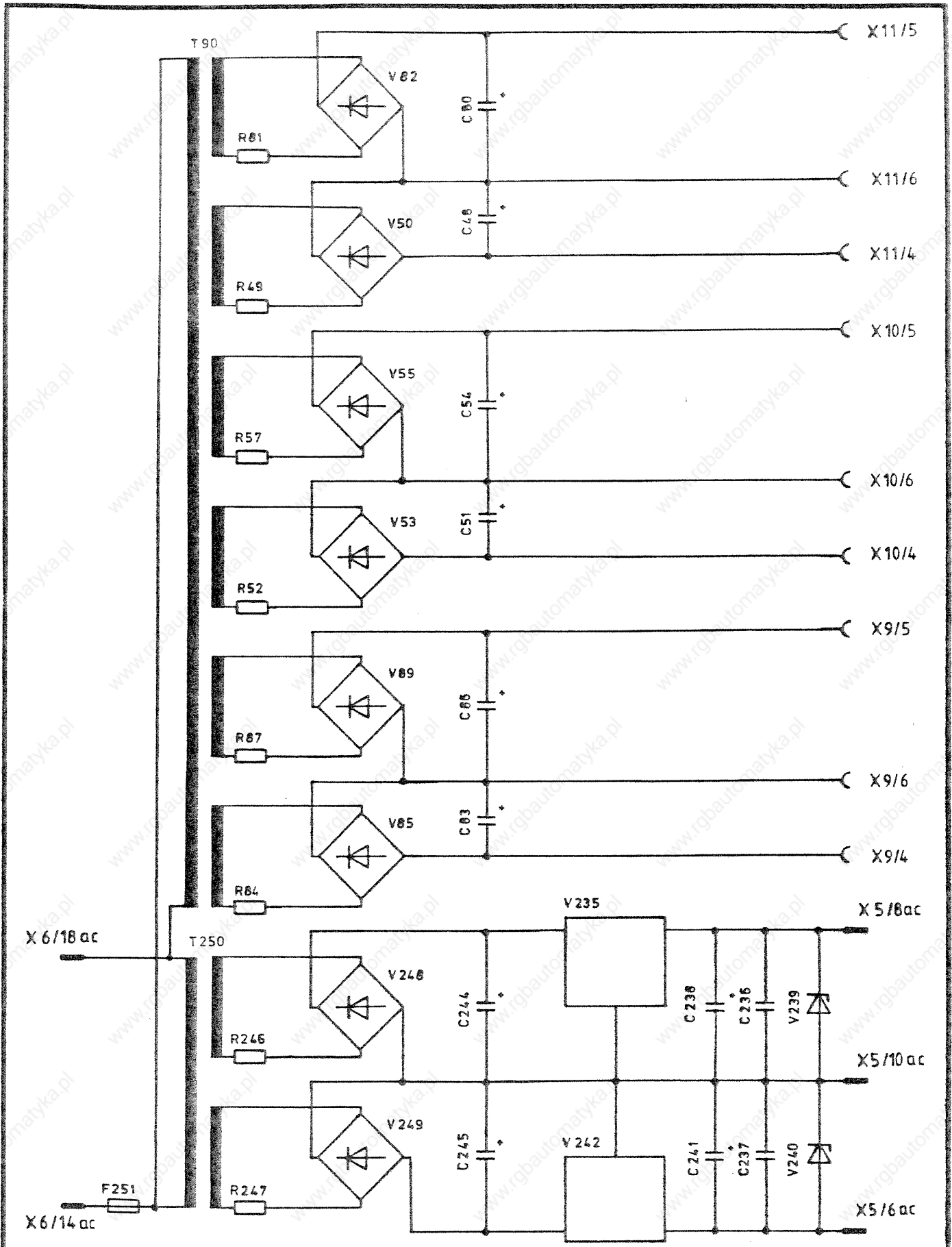

Anderungs- index	Datum	Name	Datum	Name	Benennung Current diagram KDP 2/1	
			Bearb. 23.1.84	G. Moze		
			Gepr.			
			Norm.			
<b>HAUSER Elektronik</b>					Z Nr. 03-SLP-KDP-SVC-4219 N2	Maßstab
					Ers f	Ers d

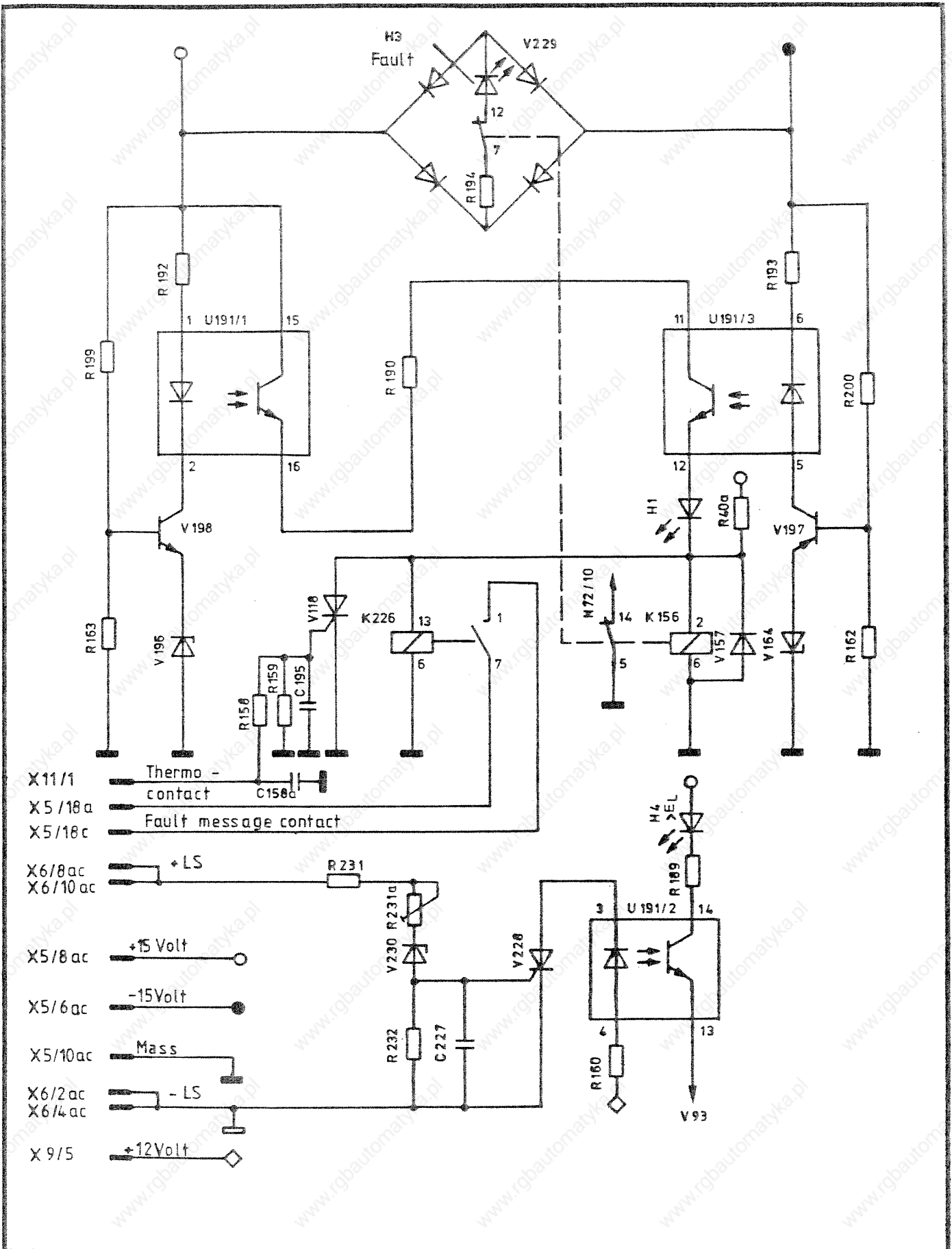

Änderungs- index	Datum	Name	Datum	Name	Benennung Current diagram KDP 2/1
			Bearb. 6.8.86	Elbe	
			Gepr.		Z Nr.: 03-SLP-KDP-SVC-421B N4
			Norm		
<b>HAUSER Elektronik</b>					Maßstab
					Blatt 1/1
Ers f					Ers d

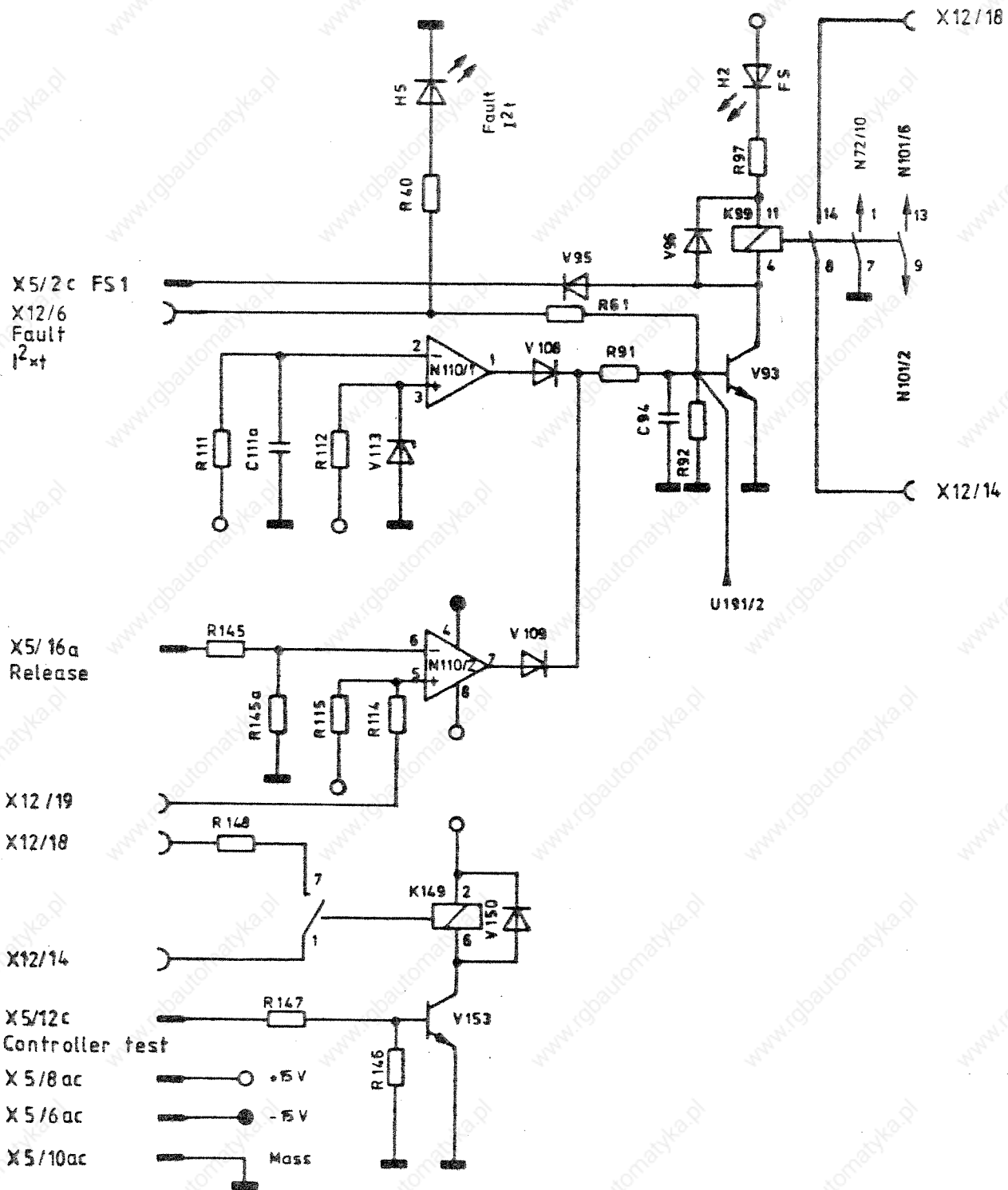

Anderungs- index	Datum	Name	Datum	Name	Benennung: <b>Current diagram</b> <b>KDP 2/1</b>	Z. Nr.: <b>03-SLP-KDP-SVC-4220 N3</b>	Maßstab
			Bearb. <b>6.8.86</b>	<b>El/ka</b>			
			Gepr.				
			Norm.				Blatt / ( / )
<b>HAUSER</b> <b>Elektronik</b>						Ers. f.:	Ers. d.:



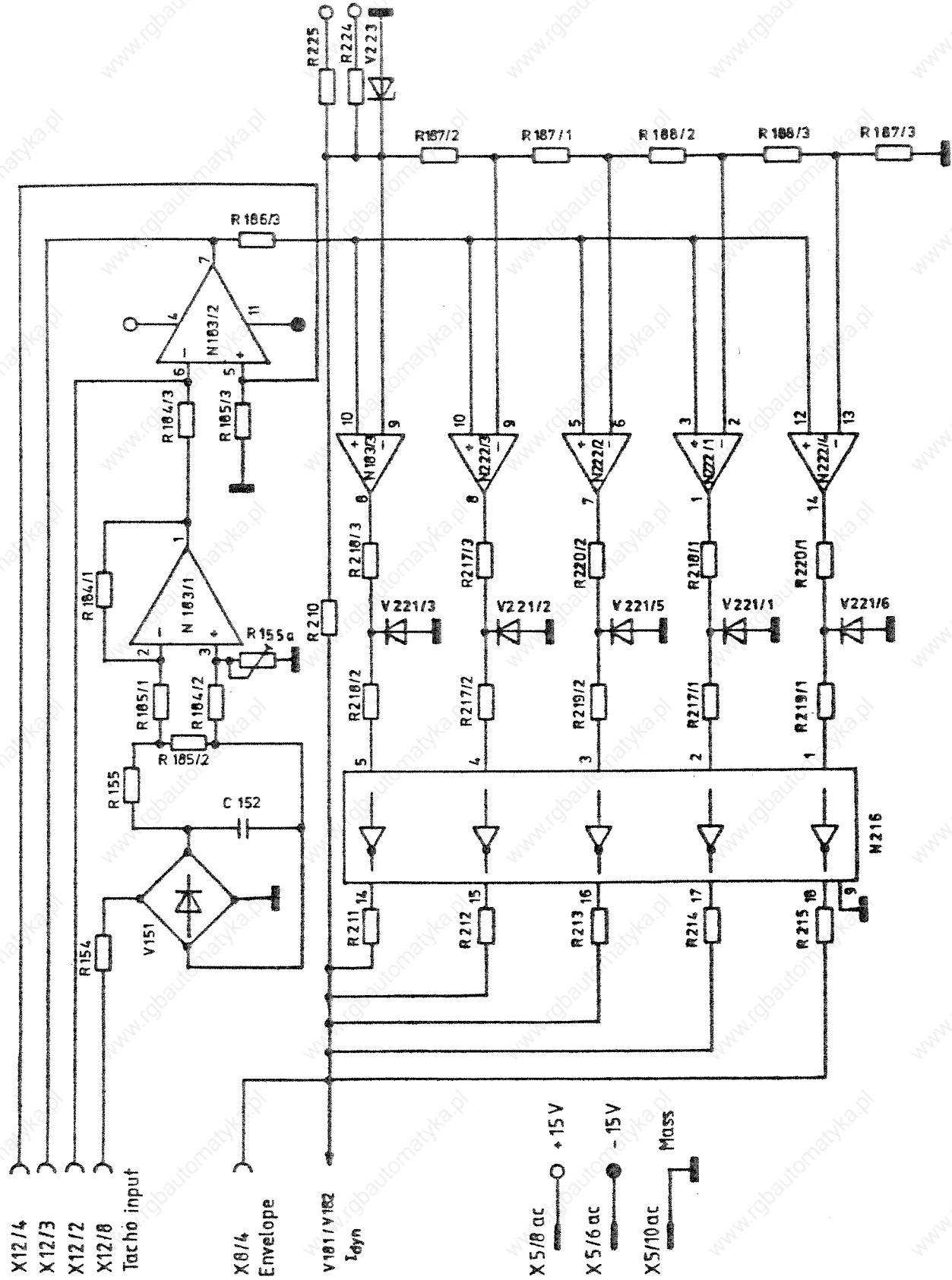

Änderungs- index	Datum	Name	Datum	Name	Benennung <b>Current diagram KDP 2/1</b>	Z. Nr. 03 - SLP - KDP - SVC - 4216 N3	Maßstab (Blatt / U)	
			Bearb.	6.1.16				slb
			Gepr.					
				Norm				
<b>HAUSER Elektronik</b>					Ers f	Ers d		

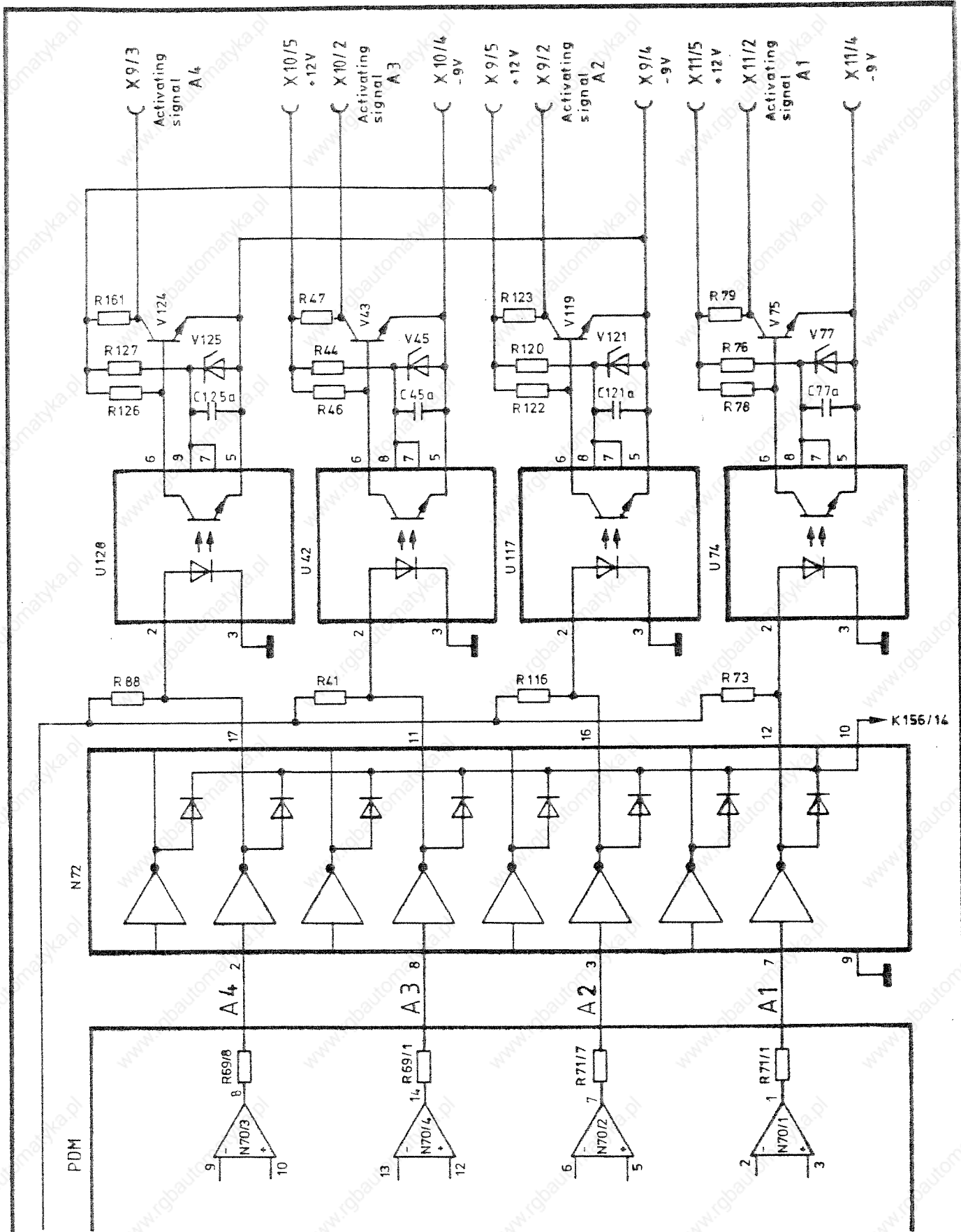

Zuerstgezeichnet (Signature)	Datum, Name (Signature)	Datum, Name Bearb. 11.9.84 <i>CLB</i> Gepr. 25.1.90 <i>Patzer</i> Name	Bezeichnung <b>Current diagram</b> <b>KDP 2/1</b>
<b>HAUSER</b> <b>Elektronik</b>			Maßstab 03 - SLP - KDP - SVC - 4217 N2 Blatt 1/1 Ers c

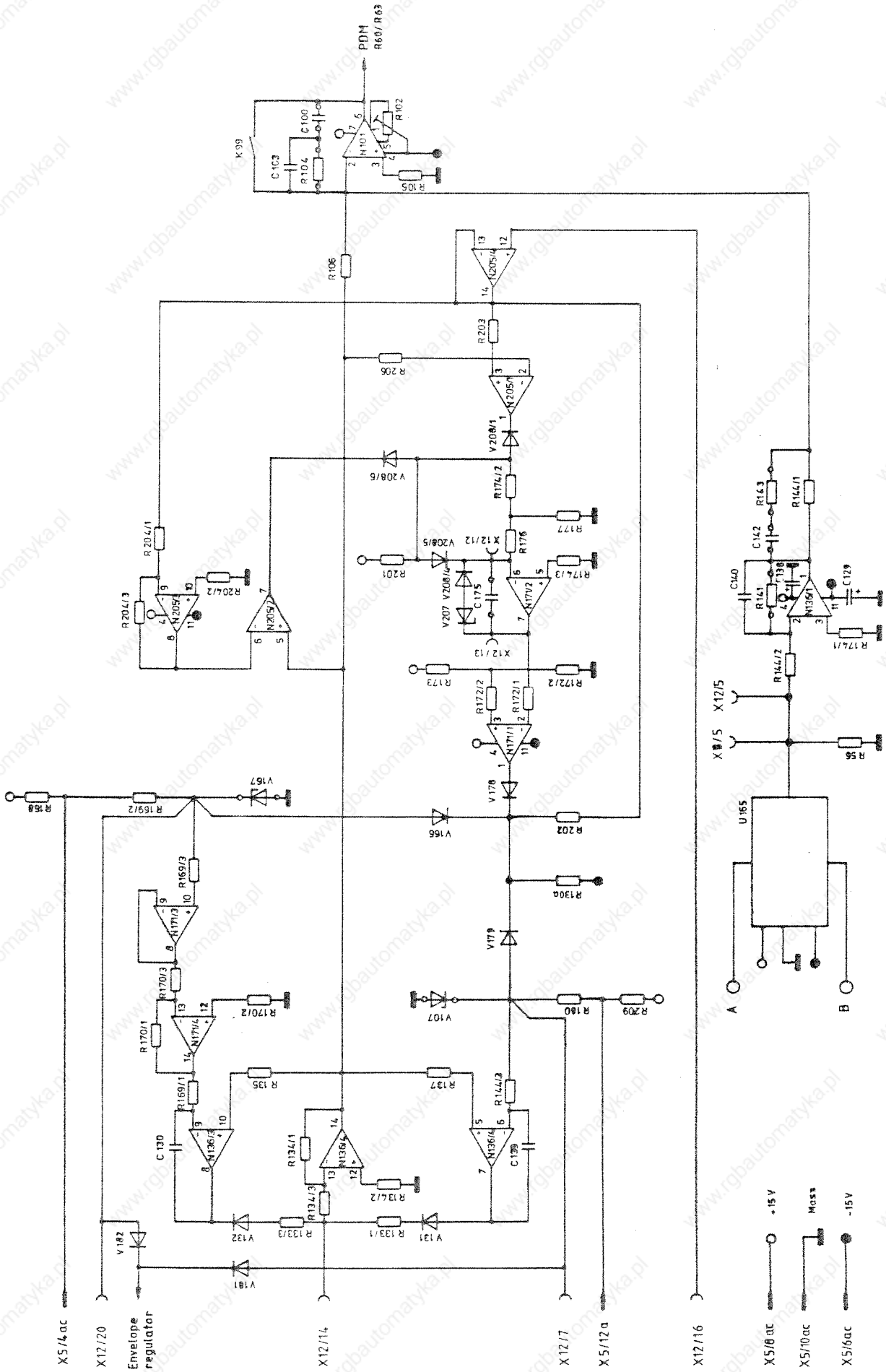

Datum		6.6.16	
Bearbeiter		EAA	
Geprüft			
Norm			
<b>KOP 2/1</b>			
Benennung		Current diagram	
Nr.		03-SLP - KDP - SVC - 4214 N3	
Blatt		1/1	

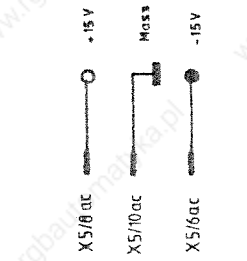

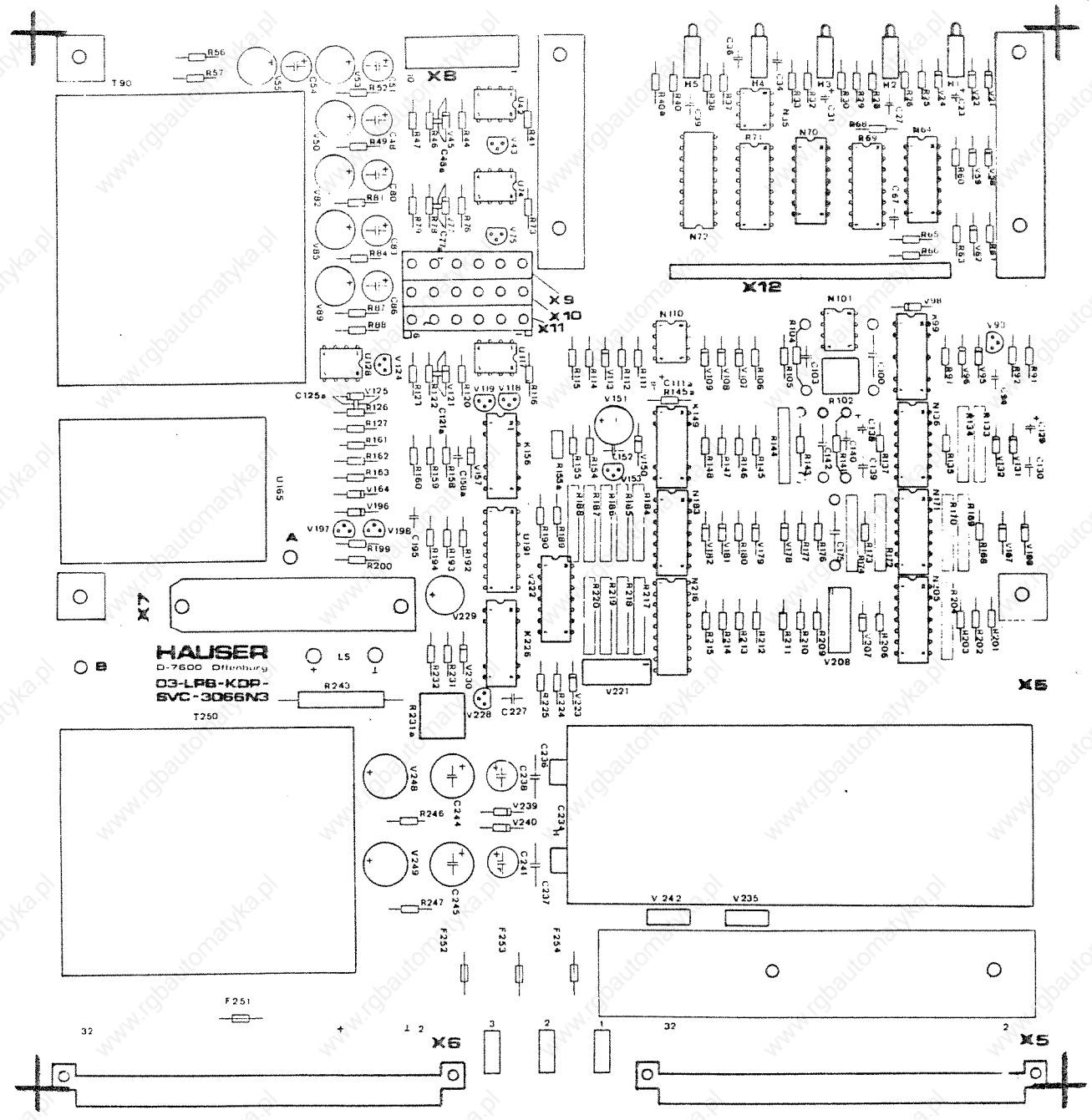

Anderungs- index	Datum	Name	84	Datum	Name	Beneennung
			Bearb.	10.6.	HL	Equipment diagramm
			Gepr.			Customer board KDP 2/1
			Norm.			
			<b>HAUSER</b> Elektronik			Z. Nr.
						03-BST-KDP-SVC-4224 N5
						Maßstab
						Dat.
						Erz. l.
						Erz. d.

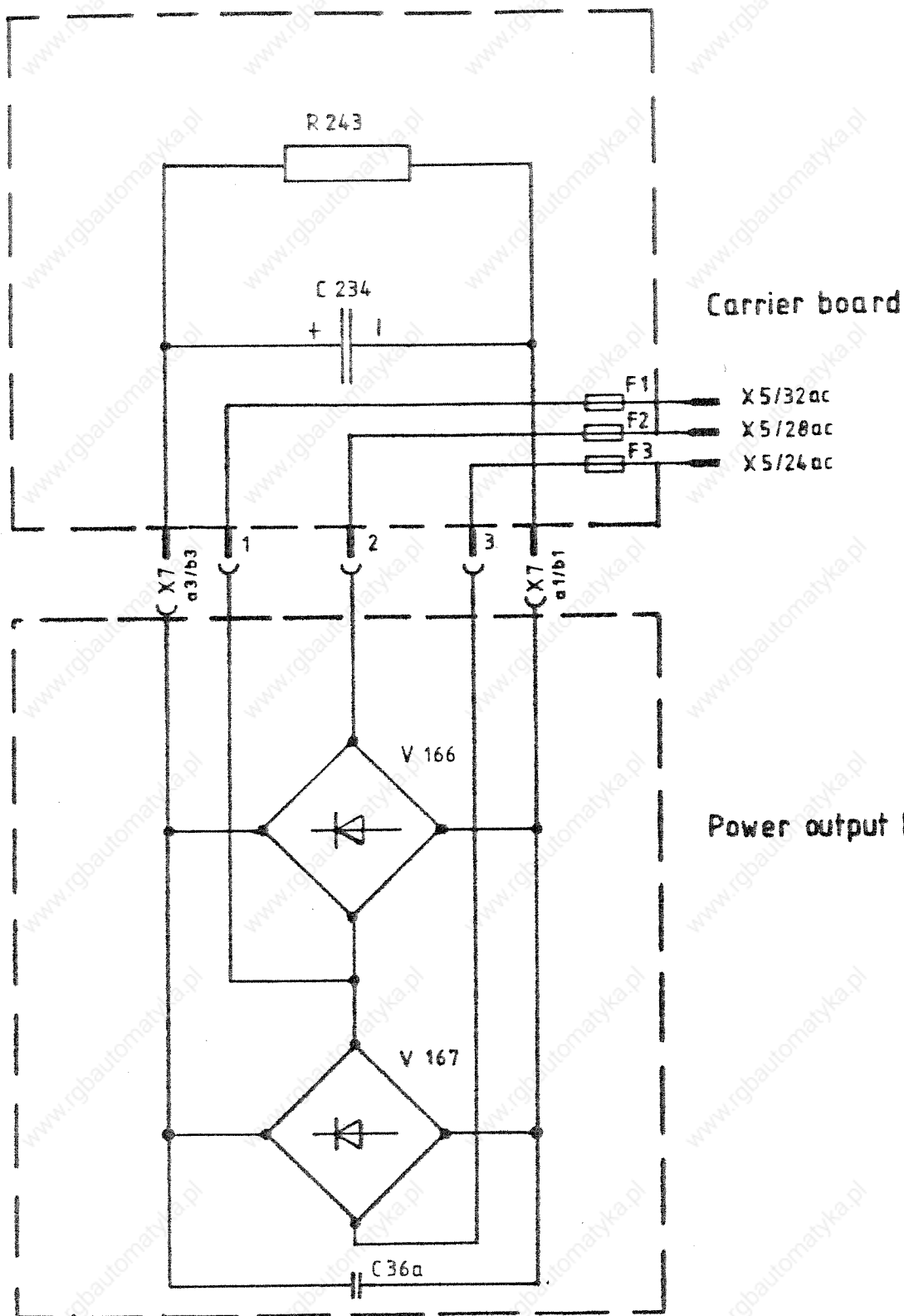

Anderungs- index	Datum	Name	Datum	Name	Benennung	
			09.11.84	Horst	Current diagram	
					LEI 6/1	
<b>HAUSER Elektronik</b>					Z. Nr.	Maßstab
					03-SLP-LEI-SVC-4221N4	
					Ers. f.	Ers. d.

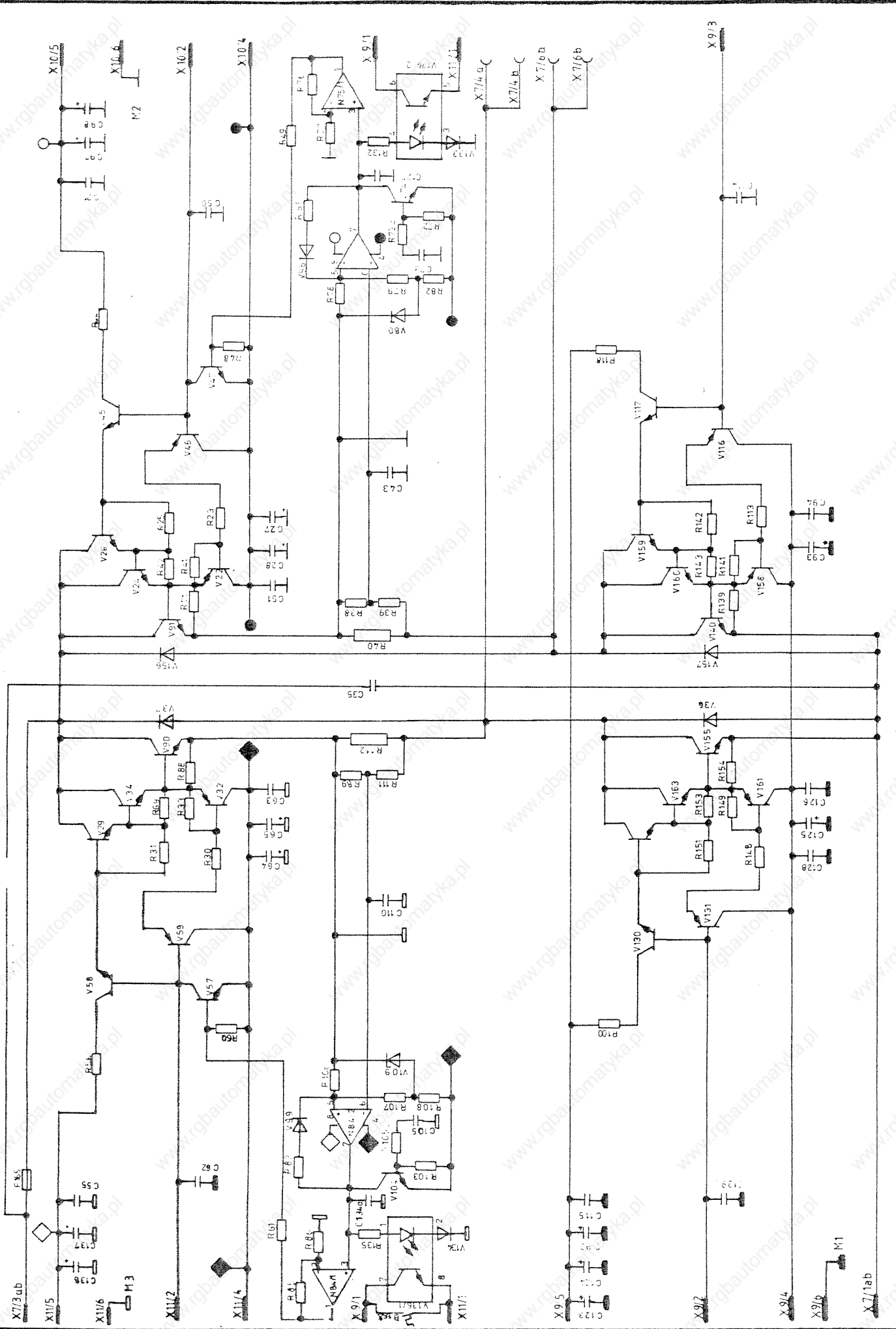

<p>Material 03-SLP-LEI-SVC-4222 N5</p>	<p>Current diagram LEI 6/1</p>	<p><b>HAUSER</b> D 7600 Offenburg</p>	<p>LEI 6/1</p>	<p>31.05.89 Patzelt Luz</p>	<p>1 2 3 4 5 6 7 8 9 10 11 12 13 14 15 16 17 18 19 20 21 22 23 24 25 26 27 28 29 30 31 32 33 34 35 36 37 38 39 40 41 42 43 44 45 46 47 48 49 50 51 52 53 54 55 56 57 58 59 60 61 62 63 64 65 66 67 68 69 70 71 72 73 74 75 76 77 78 79 80 81 82 83 84 85 86 87 88 89 90 91 92 93 94 95 96 97 98 99 100</p>
--	------------------------------------	---	----------------	-------------------------------------	--







