

LM2637 Motherboard Power Supply Solution with a 5-Bit Programmable Switching Controller and Two Linear Regulator Controllers

Check for Samples: [LM2637](#)

FEATURES

- Provides 3 Regulated Voltages
- Power Good Flag and Output Enable
- Under-Voltage Latch-Off
 - *Switching Section*
- Synchronous Rectification
- 5-bit DAC Programmable from 3.5V to 1.3V
- Typical 1% DAC Tolerance
- Switching Frequency: 50 kHz to 1 MHz
- Two Levels of Over-Voltage Protection
- Two Methods of Over-Current Protection
- Adaptive Non-Overlapping FET Gate Drives
- Soft Start Without External Capacitor
 - *Linear Section*
- N-FET and NPN Driving Capability
- Ultra Fast Response Speed
- Output Voltages Default to 1.5V and 2.5V Yet Adjustable

APPLICATIONS

- Embedded Power Supplies for PC Motherboards
- Triple DC/DC Power Supplies
- Programmable High Current DC/DC Power Supply

DESCRIPTION

The LM2637 provides a comprehensive embedded power supply solution for motherboards hosting high performance MPUs such as M II™, Pentium™ II, K6-2 and other similar high performance MPUs. The LM2637 incorporates a 5-bit programmable, synchronous buck switching controller and two high-speed linear regulator controllers in a 24-pin SO package.

Switching Section — The switching regulator controller features a 5-bit programmable DAC, over-current and over-voltage protection, under-voltage latch-off, a power good signal, and output enable. The 5-bit DAC has a typical tolerance of 1%. There are two user-selectable over-current protection methods. One provides accurate over-current protection with the use of an external sense resistor. The other saves cost by taking advantage of the r_{DS_ON} of the high-side FET. The over voltage protection provides two levels of protection. The first level keeps the high-side FET off and the low-side FET on. The second provides a gate signal that can be used to fire an external SCR.

Linear Section — The two linear regulator controllers feature wide control bandwidth, N-FET and NPN transistor driving capability, and an adjustable output voltage. The wide control bandwidth makes meeting fast load transient response requirement such as that of the GTL+ bus an easy job. In minimum configuration, the two controllers default to 1.5V and 2.5V respectively.

Both linear controllers have under voltage latch-off.



Please be aware that an important notice concerning availability, standard warranty, and use in critical applications of Texas Instruments semiconductor products and disclaimers thereto appears at the end of this data sheet.

M II is a trademark of Cyrix Corporation.

Pentium is a trademark of Intel Corporation.

All other trademarks are the property of their respective owners.

Pin Configuration

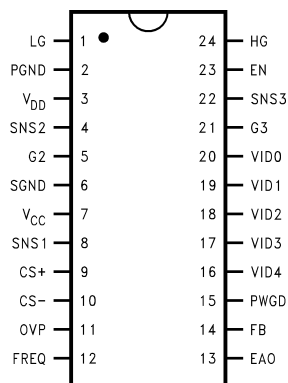

**Figure 1. 24-Lead SOIC
Top View
Package Number DW**



These devices have limited built-in ESD protection. The leads should be shorted together or the device placed in conductive foam during storage or handling to prevent electrostatic damage to the MOS gates.

Absolute Maximum Ratings⁽¹⁾⁽²⁾

V_{CC}	7V
V_{DD}	17V
Junction Temperature	150°C
Power Dissipation ⁽³⁾	1.6W
Storage Temperature	-65°C to +150°C
ESD Susceptibility	2.5 kV
Soldering Time, Temperature (10 sec.)	300°C

- (1) **Absolute Maximum Ratings** are limits beyond which damage to the device may occur. Operating ratings are conditions under which the device operates correctly. **Operating Ratings** do not imply ensured performance limits.
- (2) If Military/Aerospace specified devices are required, please contact the Texas Instruments Sales Office/Distributors for availability and specifications.
- (3) Maximum allowable power dissipation is a function of the maximum junction temperature, T_{JMAX} , the junction-to-ambient thermal resistance, θ_{JA} , and the ambient temperature, T_A . The maximum allowable power dissipation at any ambient temperature is calculated using: $P_{MAX} = (T_{JMAX} - T_A)/\theta_{JA}$. The junction-to-ambient thermal resistance, θ_{JA} , for LM2637 is 78°C/W. For a T_{JMAX} of 150°C and T_A of 25°C, the maximum allowable power dissipation is 1.6W.

Operating Ratings⁽¹⁾

V_{CC}	4.75V to 5.25V
Junction Temperature Range	0°C to +125°C

- (1) **Absolute Maximum Ratings** are limits beyond which damage to the device may occur. Operating ratings are conditions under which the device operates correctly. **Operating Ratings** do not imply ensured performance limits.

Electrical Characteristics

$V_{CC} = 5V$, $V_{DD} = 12V$ unless otherwise specified. Typical and limits appearing in plain type apply for $T_A = T_J = +25^\circ C$. Limits appearing in **boldface** type apply over the $0^\circ C$ to $+70^\circ C$ range.

Symbol	Parameter	Conditions	Min	Typ	Max	Units
I_{EN}	EN Pin internal Pull-Up Current		60	90	140	μA
I_{VID}	VID Pins internal Pull-Up Current		60	90	140	μA
I_{CC}	Operating V_{CC} Current	EN = 5V, VID = 10111		6	7.5	mA
I_{Q_VCC}	V_{CC} Shutdown Current	EN = 0V, VID Pins Floating		1.5	3	mA
SWITCHING SECTION						
V_{DACOUT}	5-Bit DAC Output Voltage	See ⁽¹⁾	<i>N</i>-1.5%	<i>N</i>	<i>N</i>+1.5%	V
I_{Q_VDD}	V_{DD} Shutdown Current	EN = 0V, VID Pins Floating		4		μA
f_{OSC}	Oscillator Frequency	RT = 100 k Ω	204	245	286	kHz
		RT = 25 k Ω		1000		
D_{MAX}	Maximum Duty Cycle			95		%
D_{MIN}	Minimum Duty Cycle			0		%
R_{SNS1}	SNS1 Pin Resistance to Ground		8.5	10	13	k Ω
R_{DS_SRC}	Gate Driver Resistance When Sourcing Current			6		Ω
R_{DS_SINK}	Gate Driver Resistance When Sinking Current			1.5		Ω
V_{CC_TH1}	Rising V_{CC} Threshold for Power-On Reset			4	4.3	V
V_{CC_TH2}	Falling V_{CC} Threshold for Power-On Reset		3.0	3.6		V
V_{DAC_IH}	DAC Input High Voltage		3.5			V
V_{DAC_IL}	DAC Input Low Voltage				1.3	V
t_{PWGD}	PWGD Response Time	SNS1 Rises from 0V to Rated Output Voltage	2	8.4	15	μs
t_{PWBAD}	PWGD Response Time	SNS1 Falls from Rated Output Voltage to 0V	2	3.4	10	μs
V_{PWGD_HI}	PWGD High Trip Point	% Above Rated Output Voltage when output Voltage \uparrow		11.5	13	%
		% Above Rated Output Voltage when output Voltage \downarrow ⁽²⁾	5	7	9	
V_{PWGD_LO}	PWGD Low Trip Point	% Below Rated Output Voltage when output Voltage \uparrow		2.6	6	%
		% Below Rated Output Voltage when output Voltage \downarrow ⁽²⁾	6	9.5	13	
V_{OVP_TRP}	OVP Pin Trip Point	% SNS1 Above Rated Output	15	18	21	%
I_{CS+}	CS+ Pin Sink Current	CS+ = 5V	126	185	244	μA
V_{OCP}	Over-Current Trip Point (CS+ and CS- Differential Voltage)	CS+ = 2V, CS- Drops from 2V	41	55	69	mV
I_{OVP}	OVP Pin Source Current	OVP = 3V	10			mA
GA	Error Amplifier DC Gain			76		dB
B_{WEA}	Error Amplifier Unity Gain Bandwidth			5		MHz
V_{RAMP_L}	Ramp Signal Valley Voltage			1.25		V
V_{RAMP_H}	Ramp Signal Peak Voltage			3.25		V
t_{SS}	Soft Start Time			4096		Clock Cycles
D_{STEP_SS}	Duty Cycle Step Change in Soft Start			12.5		%

(1) The letter **N** stands for the typical output voltages appearing in **italic boldface** type in Table 1.

(2) The output level of the PWGD pin is a logic AND of the power good function of the switching section, the 1.5V section and the 2.5V section.

Electrical Characteristics (continued)

$V_{CC} = 5V$, $V_{DD} = 12V$ unless otherwise specified. Typicals and limits appearing in plain type apply for $T_A = T_J = +25^\circ C$. Limits appearing in **boldface** type apply over the $0^\circ C$ to $+70^\circ C$ range.

Symbol	Parameter	Conditions	Min	Typ	Max	Units
1.5V LDO CONTROLLER SECTION						
V_{SNS2}	SNS2 Voltage	$V_{DD} = 12V$, $V_{CC} = 4.75V$ to $5.25V$, $I_{G2} = 0$ mA to 20 mA (Figure 2)	1.463	1.5	1.538	V
R_{OUT2}	Output Resistance			200		Ω
I_{SNS2}	SNS2 Pin Bias Current	When Regulating		21		μA
V_{PWGD_HI}	PWGD High Trip Point	See ⁽²⁾		0.63		V
V_{PWGD_LO}	PWGD Low Trip Point	See ⁽²⁾		0.44		V
2.5V LDO CONTROLLER SECTION						
V_{SNS3}	SNS3 Voltage	$V_{DD} = 12V$, $V_{CC} = 4.75V$ to $5.25V$, $I_{G3} = 0$ mA to 20 mA (Figure 2)	2.438	2.5	2.563	V
R_{OUT3}	Output Resistance			200		Ω
I_{SNS3}	SNS3 Pin Bias Current	When Regulating		21		μA
V_{PWGD_HI}	PWGD High Trip Point	See ⁽²⁾		0.63		V
V_{PWGD_LO}	PWGD Low Trip Point	See ⁽³⁾		0.44		V

- (3) The output level of the PWGD pin is a logic AND of the power good function of the switching section, the 1.5V section and the 2.5V section.

Table 1. 5-Bit DAC Output Voltage Table ($V_{CC} = 5V$, $V_{DD} = 12V \pm 5\%$, $T_A = 25^\circ C$, Test Mode)

Symbol	Parameter	Conditions	Typical	Units
V_{DACOUT}	5-Bit DAC Output Voltages for Different VID Codes	VID4:0 = 01111	1.30	V
		VID4:0 = 01110	1.35	
		VID4:0 = 01101	1.40	
		VID4:0 = 01100	1.45	
		VID4:0 = 01011	1.50	
		VID4:0 = 01010	1.55	
		VID4:0 = 01001	1.60	
		VID4:0 = 01000	1.65	
		VID4:0 = 00111	1.70	
		VID4:0 = 00110	1.75	
		VID4:0 = 00101	1.80	
		VID4:0 = 00100	1.85	
		VID4:0 = 00011	1.90	
		VID4:0 = 00010	1.95	
		VID4:0 = 00001	2.00	
		VID4:0 = 00000	2.05	
		VID4:0 = 11111	(shutdown)	
		VID4:0 = 11110	2.1	
		VID4:0 = 11101	2.2	
		VID4:0 = 11100	2.3	
		VID4:0 = 11011	2.4	
		VID4:0 = 11010	2.5	
		VID4:0 = 11001	2.6	
		VID4:0 = 11000	2.7	
		VID4:0 = 10111	2.8	
		VID4:0 = 10110	2.9	
		VID4:0 = 10101	3.0	
		VID4:0 = 10100	3.1	
VID4:0 = 10011	3.2			
VID4:0 = 10010	3.3			
VID4:0 = 10001	3.4			
VID4:0 = 10000	3.5			

BLOCK DIAGRAM

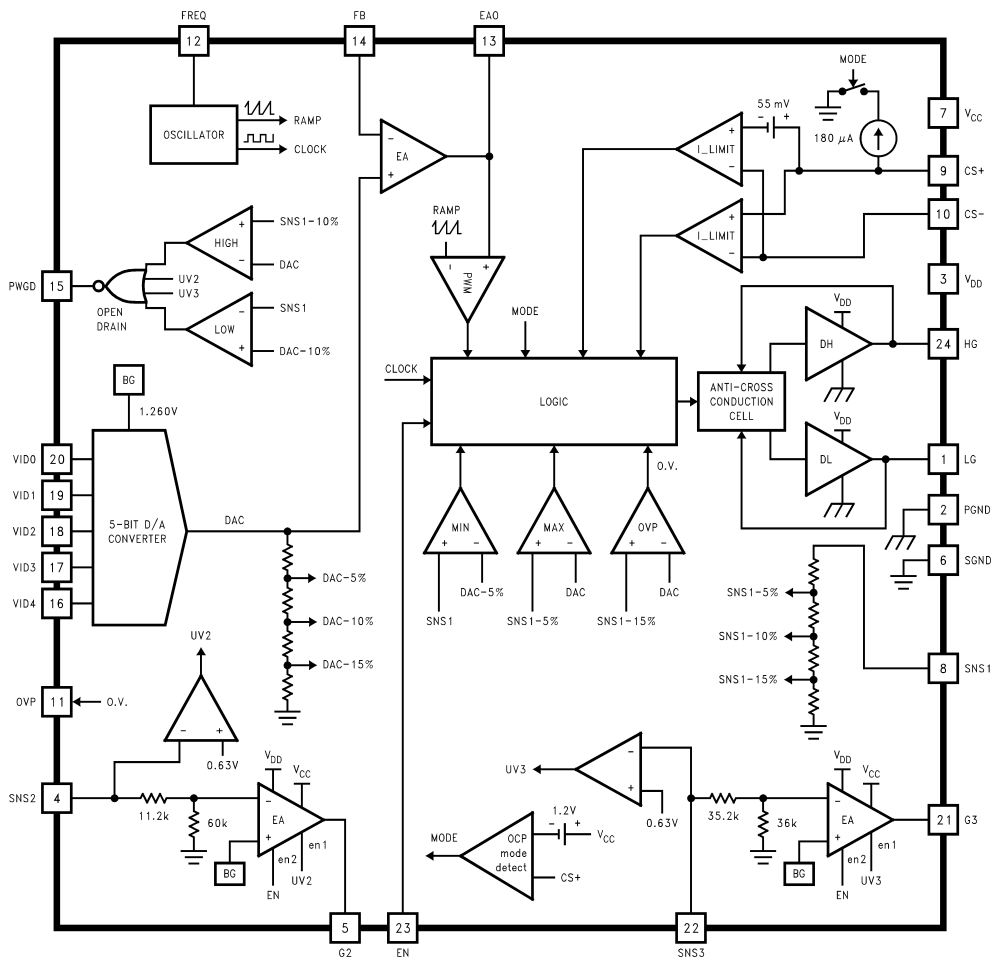

Test Circuit

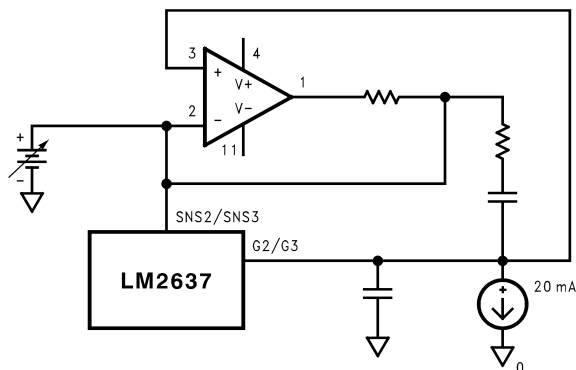
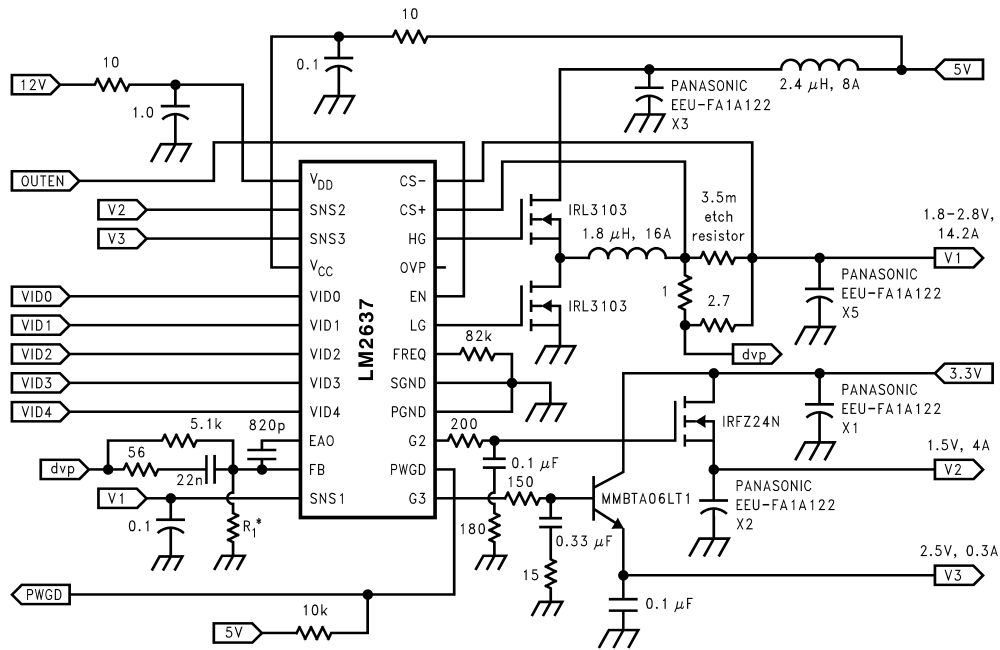

Figure 2. LDO Controller Test Circuit

Typical Applications



* R_1 is for raising the switcher output voltage slightly. Its value depends on the output voltage.

Figure 3. Motherboard Power Supply for Pentium II Processor Core (1.3V - 2.8V, 14.2A), GTL+ Bus (1.5V, 4A), and Legacy I/O (2.5V, 0.3A). External sense resistor is used to provide both over-current limit and dynamic voltage positioning.

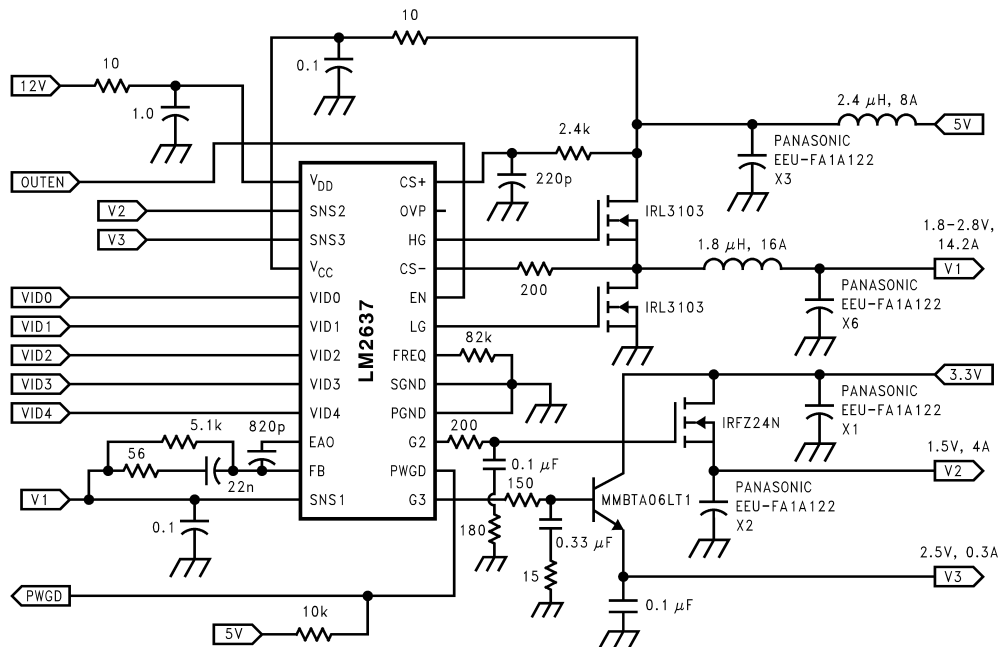
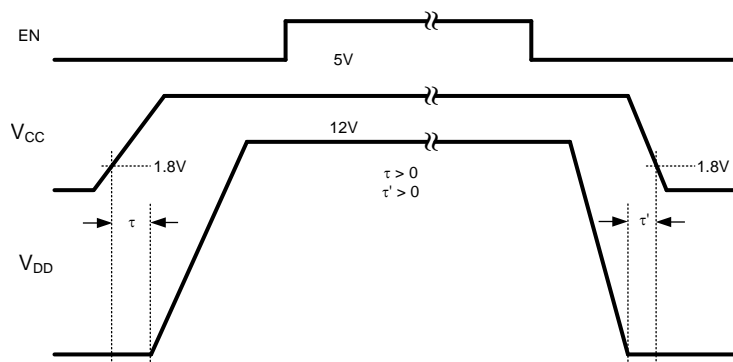

Figure 4. Motherboard Power Supply for Pentium II Processor Core (1.8V - 2.8V, 14.2A), GTL+ Bus (1.5V, 4A), and Legacy I/O (2.5V, 0.3A). High side FET is used to provide the current limit.

PIN DESCRIPTION

Pin	Pin Name	Pin Function
1	LG	Low side N-FET gate driver output.
2	PGND	Ground for the two FET drivers of the switching section.
3	V _{DD}	Supply for the FET gate drivers. Usually tied to +12V.
4	SNS2	Feedback pin for the 1.5V linear regulator.
5	G2	Gate drive output for the external N-MOS of the fast 1.5V linear regulator.
6	SGND	Ground for internal signal circuitry and system ground reference.
7	V _{CC}	Supply voltage. Usually +5V.
8	SNS1	Output voltage monitor input for the switching regulator.
9	CS+	Switching regulator current sense input, positive node.
10	CS-	Switching regulator current sense input, negative node.
11	OVP	Over-voltage protection output for the switching regulator. Can be used to fire an external SCR.
12	FREQ	Switching frequency adjustment pin. An external resistor is needed to set the desired frequency.
13	EAO	Output of the error amplifier. Used for compensating the switching regulator.
14	FB	Inverting input of the error amplifier. Used for compensating the switching regulator.
15	PWGD	Open collector Power Good signal.
16	VID4	5-Bit DAC input, MSB.
17	VID3	5-Bit DAC input.
18	VID2	5-Bit DAC input.
19	VID1	5-Bit DAC input.
20	VID0	5-Bit DAC input, LSB.
21	G3	Gate drive pin for the external N-MOS of the 2.5V linear regulator.
22	SNS3	Feedback pin for the 2.5V linear regulator.
23	EN	Output Enable. A logic low shuts the whole chip down.
24	HG	High side N-FET gate driver output.

Preferred Startup Timing



See Start Up section in Application Information.

APPLICATIONS INFORMATION

OVERVIEW

The LM2637 provides control and protection for three voltage regulators. Namely, a synchronous buck switching controller and two linear regulator controllers that drive an external N-FET or NPN transistor.

Switching Section—The switching controller features a VRM-compatible, 5-bit programmable output voltage, over-current and over-voltage protection, under-voltage latch-off, a power good signal, and an output enable. The 5-bit DAC has a typical tolerance of 1%. There are two user-selectable over-current protection methods. One provides accurate over-current protection with the use of an external sense resistor. The other saves cost by taking advantage of the r_{DS_ON} of the high-side FET. The over-voltage protection provides two levels of protection. The first turns off the high-side FET and turns on the low-side. The second provides a gate signal that can be used to fire an external SCR.

The PWM frequency is adjustable from 50 kHz to beyond 1 MHz through an external resistor.

Soft start is realized through an internal digital counter. No external soft start capacitor is necessary.

Dynamic positioning of the switcher output voltage reduces the number of output capacitors and can be easily realized using the same sense resistor as the over-current protection.

Linear Section—The two linear regulator controllers feature wide control bandwidth, N-FET and NPN transistor driving capability, an adjustable output voltage and a typical 2% tolerance. The wide control bandwidth makes meeting the GTL+ bus transient response requirement an easy job. When no external resistor divider is used, the two controllers default to 1.5V and 2.5V respectively.

Both linear sections have under-voltage latch-off. Should the output voltage drop below 0.63V, the corresponding gate drive will be disabled and PWGD pin will be pulled low.

THEORY OF OPERATION

Start Up

Switching Section—The soft start circuitry starts to work when three conditions are met, i.e., EN pin is a logic high, the VID code is valid and V_{CC} pin voltage exceeds 4.2V. The duration of the soft start is determined by an internal digital counter and the switching frequency. During soft start, the output of the error amplifier is allowed to increase gradually. When the counter has counted 4,096 clock cycles, soft start session ends and the output level of the error amplifier is released and allowed to go to a value that is determined by the feedback loop. PWRGD pin is always low during soft start and is turned over to output voltage monitoring circuitry after that. Before V_{CC} reaches 4V, all internal logic is in a power-on-reset state and the two FET drivers are disabled.

The power supply designer is cautioned to avoid the situation when V_{DD} is higher than 1V while V_{CC} is less than 1.8V. When V_{CC} is less than 1.8V, the internal circuitry of the LM2637 may not be in a controlled state. If at this time V_{DD} of greater than 1V is applied, the HG and LG may be pulled up simultaneously, causing a potential shoot-through and thus possibly preventing V_{CC} to come up properly. See Preferred Startup Timing for the recommended timing sequence.

During normal operation, if V_{CC} voltage drops below 3.6V, the internal circuitry will go into power-on-reset again. The hysteresis helps decrease the noise sensitivity on the V_{CC} pin.

After soft start ends and during normal operation, if the converter output voltage exceeds 118% of DAC output voltage, the LM2637 will lock into over-voltage protection mode. The high-side drive will be low, and the low-side drive will be high. There are two ways to clear the mode. One is to cycle V_{CC} voltage once. The other is to toggle the EN level. After the over-voltage protection mode is cleared, the LM2637 will enter the soft start session and start over.

Linear Section—The linear section does not go through a soft start. Whenever the soft start of the switching section begins, the linear section immediately applies the required gate voltages or base currents for external power transistors. There is an under-voltage latch-off for the linear section. If after soft start ends, SNS2 or SNS3 is below 0.63V, the corresponding gate drive will be disabled and PWGD pin will be pulled low.

Normal Operation

Switching Section—In the normal operation mode, the LM2637 regulates the converter output voltage by adjusting the duty ratio. The output voltage is determined by the 5-bit VID code set by the user or MPU.

The PWM frequency is set by an external resistor between FREQ pin and ground. The resistance needed for a desired PWM frequency can be determined by the following equation:

$$R = \frac{25,000}{f(\text{kHz})} \text{ k}\Omega \quad (1)$$

For example, if the desired PWM frequency is 300 kHz, the resistance should be around 84 k Ω .

The minimum allowable PWM frequency is 5 kHz.

Linear Section—Under steady state operation, the linear section supplies the appropriate gate voltage or base current to correctly bias the external pass transistor so that the voltage drop across the transistor is the right value.

Resetting the LM2637

When the LM2637 detects an abnormal condition such as switching regulator over voltage, it will latch itself off partially or completely. To reset the LM2637, either EN or V_{CC} voltage has to be toggled. Another more subtle way to recover is to float all the VID pins and reapply the correct code.

Gate Drives

Switching Section—The switching controller has two gate drives that are suitable for driving external power N-FETs in a synchronous buck topology. The voltage for the two FET drivers is supplied by the V_{DD} pin. This V_{DD} voltage should be at least one V_{GS(th)} higher than converter input voltage to be able to fully enhance the high-side FET. In a typical PC motherboard application, it is recommended that 12V be applied to V_{DD}, and 5V be used as the input voltage for the switcher. A charge pump is not recommended since the linear sections need a stable V_{DD} voltage to minimize high frequency noise.

For a V_{DD} of 12V, the peak gate charging current is typically 2A, and the peak gate discharging current is typically 6A, well suited for high speed switching.

The LM2637 gate drives are of BiCMOS design. Unlike some bipolar control ICs, the gate drive has rail-to-rail swing that ensures no spurious turn-on due to capacitive coupling.

Another feature of the FET gate drives is the adaptive non-overlapping mechanism. A gate drive is not turned on until the other is fully off. The dead time in between is typically 20 ns. This avoids the potential shoot-through problem and helps improve efficiency.

Linear Section—The gate drives of the linear section can put out a maximum continuous current of about 40 mA. The typical low gate voltage is 1.2V.

Load Transient Response

Switching Section—In a typical modern MPU application such as the M II, Pentium II and K6-2 core power supply, load transient response is a critical issue. The LM2637 utilizes the conventional voltage feedback technology as the primary feedback control method. When the load transient happens, the error in the output voltage level is fed to the error amplifier. The output of the error amplifier is then compared with an internally generated PWM ramp signal and the result of the comparison is a series of pulses with certain duty ratios. These pulses are then used to control the on and off of the FET gate drives. In this way, the error in the output voltage gets corrected by the change in the duty ratio of the FET switches. During a large load transient, depending on the compensation design, the change in duty ratio usually begins within one switching cycle. Refer to the *Design Considerations* section for more details.

Besides the voltage feedback control loop, the LM2637 also has a pair of fast comparators (the MIN and MAX comparators) to help maintain the output voltage during a large and fast load transient. The trip points of the comparators are set to $\pm 5\%$ of the DAC output voltage. When the load transient is so large that the output voltage goes outside the $\pm 5\%$ window, the MIN or MAX comparator will bypass the primary voltage control loop and immediately set the duty ratio to either 100% or 0%. This provides the fastest possible way to react to such a large load transient in a conventional buck converter.

Linear Section—The linear section has a high control bandwidth. Depending on external components selected, the typical bandwidth can be as high as 1.2 MHz. The user may choose to lower this bandwidth and have a better noise immunity by adding a small capacitor (1 nF to 10 nF) between the gate output and ground.

Power Good Signal

The power good signal is to indicate whether all three output voltages are within their corresponding range. The range for the switching regulator is set to a typical $\pm 10\%$ window of the DAC output voltage. The range for the linear regulator is 0.63V to infinity. During soft start, the power good signal is kept low. At the completion of soft start, all three output voltages are checked and the PWGD pin will be asserted if they are all within specified range. During normal operation, whenever a voltage goes out of the specified range for more than about 3 μ s, PWGD pin will be pulled low.

Over-Voltage Protection

Switching Section—When the output voltage exceeds 118% of the DAC output voltage any time beyond the soft start, the switching section will enter over-voltage protection mode and shuts itself down. The upper gate drive will be held low while the lower gate drive will be held high. PWGD will be low. There will also be a logic high signal at the OVP pin that can be used to fire an external SCR. To clear this mode, refer to the *Resetting the LM2637* section.

Linear Section—There is no over-voltage protection in the linear controllers.

Under-Voltage Latch-Off

At the completion of soft start, the controller starts to monitor all three output voltages. If any of the voltages goes below about 0.63V, the controller will latch off its corresponding section, i.e., switching or linear. The mode can be cleared by following the procedures described in the *Resetting the LM2637* section.

Current Limit

Switching Section—Current limit can be realized by two methods. One method is through sensing the V_{DS} of the high-side FET. The other is through a separate sense resistor. The first method is cheaper and more power efficient but less accurate. The second method is more accurate but dissipates additional power and is either more expensive or requires special PCB layout consideration. A side benefit of the second method is it enables implementation of a technique called dynamic voltage positioning, which helps save the number of output capacitors.

The LM2637 tells in which current limit mode it is supposed to be by detecting the CS+ pin voltage. When CS+ voltage is 1.2V below V_{CC} voltage, sense resistor method is assumed. Otherwise the V_{DS} method is chosen. The V_{DS} method is based on typical r_{DS_ON} of the high-side FET and load current levels.

Method 1—High-Side FET V_{DS} Sensing

This method detects the high-side FET drain current by sensing its drain-source voltage when it is on. See [Figure 5](#). Since the r_{DS_ON} of a FET is a known value, current through the FET can be known by measuring its V_{DS} . The relationship between the three parameters is:

$$I = \frac{V_{DS}}{r_{DS_ON}} \quad (2)$$

To implement the current limit function, an external resistor R_{IMAX} is needed. The resistor should be connected between the drain of the high-side FET and IMAX pin. A constant current of around 180 μ A is forced to flow into the IMAX pin and causes a fixed voltage drop across the R_{IMAX} resistor. This voltage drop is then compared with the V_{DS} of the high-side FET and if the latter is higher, over current is assumed. The appropriate value of R_{IMAX} for a pre-determined current limit level I_{LIM} can be determined by the following equation:

$$R_{IMAX} = \frac{r_{DS_ON} \times I_{LIM}}{I_{IMAX}} \quad (3)$$

For example, suppose that the r_{DS_ON} of the FET is 20 m Ω , and the desired current limit is 20A, then R_{IMAX} should be 2.2 k Ω .

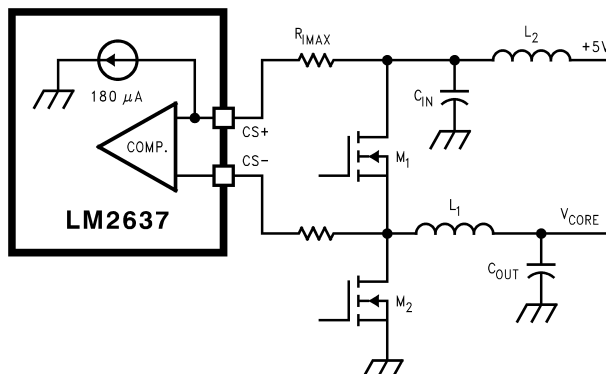

Figure 5. Current Limit via High-Side FET V_{DS} Sensing

Notice however, that the r_{DS_ON} of the FET has a positive temperature coefficient and it can increase by as much as 50% when heated up. Also the distribution of the r_{DS_ON} can be fairly wide, a 1.25 to 1.5 ratio is not uncommon. Consult the MOSFET vendor for further information on the distribution of r_{DS_ON} .

The designer should carefully choose the value of R_{1MAX} so that even under the extreme case (largest r_{DS_ON} and highest temperature) the current limit will not trigger below the preset value.

To provide the greatest protection over the high-side FET, cycle-by-cycle protection is implemented. The sampling of the V_{DS} starts as early as 250 ns after the FET is turned on. Whenever an over-current condition is detected, the high-side FET is immediately turned off and the low-side FET turned on. This status remains for the rest of the cycle. The same procedure applies to the next switching cycle. The blanking time of 250 ns is to avoid the switching noise that occurs whenever the FET is turned on.

The resistor between CS- pin and the switching node (source of the high-side FET) is important for minimizing the noise and negative voltage present at the CS- pin. A resistance of 100Ω to 300Ω is recommended.

Method 2—Current Sense Resistor

This method uses a sense resistor in series with the output inductor to detect the load current. See [Figure 6](#). The voltage across the sense resistor is proportional to load current. In the case that the sense resistor is of discrete type (i.e., not a PCB etch resistor) or the sense resistor value is optimized for dynamic voltage positioning (see the *Dynamic Positioning of Load Voltage* section), it may be necessary to use two signal level resistors, R_1 and R_2 to appropriately set the desired current limit.

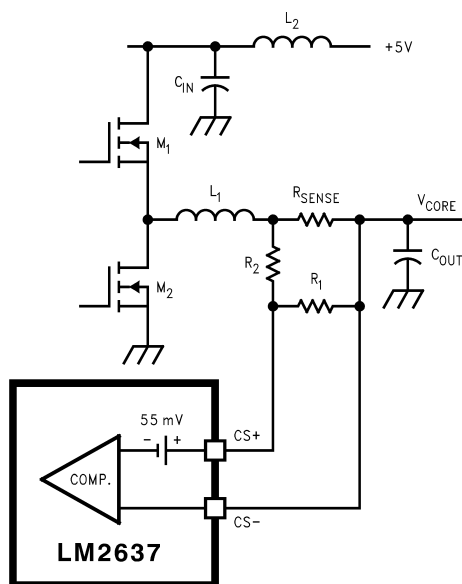

Figure 6. Current Limit via Current Sense Resistor

For a given current limit value, the minimum R_{SENSE} is determined by:

$$R_{\text{SENSE min}} = \frac{V_{\text{OCP}}}{I_{\text{LIM}}} \quad (4)$$

where V_{OCP} is the over-current trip voltage and is typically 55 mV, see the *Electrical Characteristic* table. For example, for a 20A current limit, the minimum R_{SENSE} is 2.75 mΩ. If a 3 mΩ sense resistor is used instead, use appropriate values of R_1 and R_2 to make the voltage across R_1 to be V_{OCP} when the voltage across R_{SENSE} is 60 mV.

The discrete current sense resistor usually has a very good temperature coefficient and tolerance. A temperature coefficient of ± 30 ppm/°C is typical. Tolerance is usually $\pm 1\%$ or $\pm 5\%$. Vishay Dale and IRC offer a broad range of discrete sense resistors.

A PCB etch resistor can also be used as the R_{SENSE} . The advantage of that approach is flexible resistance, which will result in minimum power loss. R_1 and R_2 may also be eliminated. The drawback is too high a temperature coefficient, typically +4000 ppm/°C, which will result in a much less accurate current limit than a discrete sense resistor. The copper thickness of a PCB is usually of 5% tolerance.

Linear Section—There is no current limit function in the linear controllers. However, if there is ever a severe overload, the output voltage may drop below 0.63V, in which case the under-voltage latch-off will provide the protection.

DESIGN CONSIDERATIONS

Control Loop Compensation

Switching Section—A switching regulator should be properly compensated to achieve a stable operation, tight regulation and good dynamic performance. For a synchronous buck regulator that needs to meet stringent load transient requirement such as that of processor core voltage supply, a 2-pole-1-zero compensation network should suffice, such as the one shown in [Figure 7](#) (C_1 , C_2 , R_1 and R_2). This is because the ESR zero of the typical output capacitors is low enough to make the control-to-output transfer function a single-pole roll-off.

As an example, let us figure out the values of the compensation network components in [Figure 7](#). Assume the following parameters: $R = 20\Omega$, $R_L = 20$ mΩ, $R_C = 9$ mΩ, $L = 2$ μH, $C = 7.5$ mF, $V_{\text{IN}} = 5$ V, $V_m = 2$ V and PWM frequency = 300 kHz. Notice R_L is the sum of the inductor DC resistance and the on resistance of the FET's.

The control-to-output transfer function is:

$$\begin{aligned} \text{TF1} &= \frac{\tilde{V}_{\text{out}}}{\tilde{V}_{\text{control}}} \\ &= \frac{R \cdot V_{\text{IN}} \cdot (\text{SCR}_C + 1)}{s^2 LC (R + R_C) + s[L + R_L C (R + R_C) + RR_C C] + R + R_L} \cdot \frac{1}{V_m} \end{aligned} \quad (5)$$

The ESR zero frequency is:

$$f_{\text{ESR}} = \frac{1}{2\pi CR_C} = 2.36 \text{ kHz} \quad (6)$$

The double pole frequency is:

$$f_{2P} = \frac{1}{2\pi} \sqrt{\frac{R + R_L}{LC(R + R_C)}} = 1.3 \text{ kHz} \quad (7)$$

The corresponding Bode plots are shown in [Figure 8](#).

Notice since the ESR zero frequency is so low that the phase doesn't even go beyond -90° . This makes the compensation easier to do.

Since the DC gain and cutoff frequency (0 dB frequency) are too low, some compensation is needed. Otherwise the low DC gain will cause a poor line regulation, and the low cutoff frequency may hurt transient response performance.

The transfer function for the 2-pole-1-zero compensation network shown in [Figure 7](#) is:

$$TF2 = \frac{SC_1(R_1 + R_2) + 1}{-SC_2R_1(SC_1R_2 + 1)} = \frac{\frac{S}{2\pi f_z} + 1}{-A \cdot S \left(\frac{S}{2\pi f_p} + 1 \right)} \quad (8)$$

where

$$f_z = \frac{1}{2\pi C_1(R_1 + R_2)}, \quad f_p = \frac{1}{2\pi C_1 R_2}, \quad A = R_1 \cdot C_2. \quad (9)$$

One of the poles is located at origin to help achieve the highest DC gain. So there are three parameters to determine, the position of the zero, the position of the second pole, and the constant A. To determine the cutoff frequency and phase margin, the loop bode plots need to be generated. The loop transfer function is:

$$TF = -TF1 \times TF2 \quad (10)$$

By choosing the zero close to the double pole position and the second pole to half of the switching frequency, the closed loop transfer function turns out to be very good.

That is, if $f_z = 1.32$ kHz, $f_p = 153$ kHz, and $A = 4.8 \times 10^{-6}$ ΩF , then the cutoff frequency will be 50 kHz, the phase margin will be 72° , and the DC gain will be that of the error amplifier. See [Figure 9](#).

The compensation network component values can be determined by [Equation 9](#), since the values of f_z , f_p and A are now known. To more conveniently calculate the values, [Equation 9](#) can be rearranged as follows:

$$C_1 R_1 = \frac{1}{2\pi} \cdot \left(\frac{1}{f_z} - \frac{1}{f_p} \right), \quad C_1 R_2 = \frac{1}{2\pi f_p}, \quad C_2 = \frac{A}{R_1} \quad (11)$$

Notice there are three equations but four variables. So one of the variables can be chosen arbitrarily. Since the current driving capability of the error amplifier is limited to around 3 mA, it is a good idea to have a high impedance path from EAO to FB. From [Equation 11](#) it can be told that a larger R_2 will result in a smaller C_1 , C_2 and a larger R_1 . Calculations show that the following combination is a good one: $R_2 = 51\Omega$, $C_1 = 0.022$ μF , $R_1 = 5.6$ k Ω , $C_2 = 820$ pF.

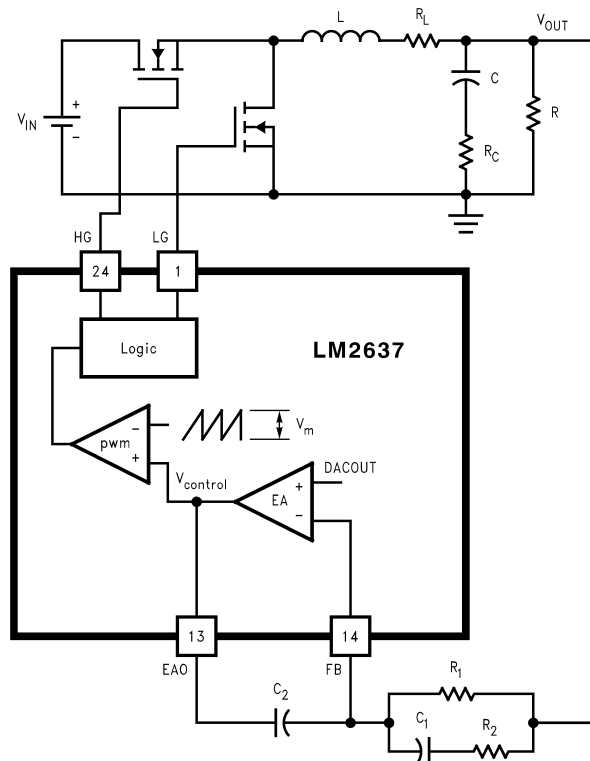

Figure 7. Buck Converter from a Control Viewpoint

For a different application or different type of output capacitors, a different compensation scheme may be necessary. The user can either follow the steps above to figure the appropriate component values or contact Texas Instruments for help.

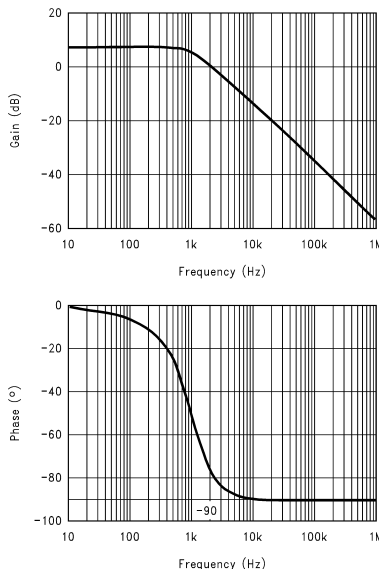

Figure 8. Control-to-Output Bode Plots

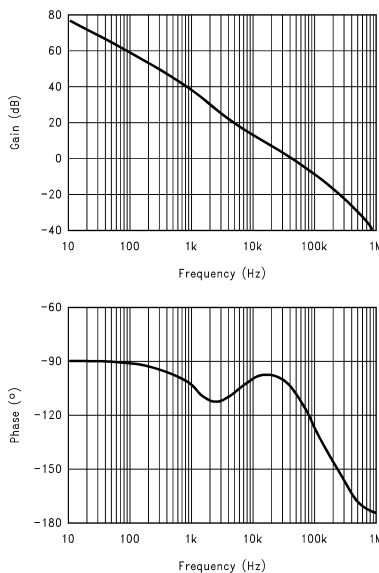

Figure 9. Loop Bode Plots

Linear Section—The linear section is designed for high control bandwidth operation. The phase margin and cutoff frequency depends on the external N-FET, output capacitors and their ESR. As a rule of thumb, the designer can choose any capacitance from 50 μF to 4000 μF , with a total ESR of 10 $\text{m}\Omega$ to 100 $\text{m}\Omega$. The larger the capacitance, the lower the bandwidth. The above capacitors usually result in a control bandwidth of 250 kHz to 1.2 MHz.

FET Selection

Switching Section—The selection of FET switches affects both the efficiency of the whole converter and the current limit setting (if V_{DS} sensing mode is selected). From efficiency standpoint it is suggested that for the high-side switch, only logic level FETs be used. Standard FETs can be used for the low-side switch when 12V is used to power the V_{DD} pin. The power loss associated with the FETs is two-fold—Ohmic loss and switching loss. The Ohmic loss is relatively easy to calculate whereas the switching loss is much more difficult to estimate. The switching loss in a synchronous buck converter usually happens only in the high-side FET. When the high-side FET starts to turn on, inductor current is flowing in the low-side body diode. Since the body diode undergoes a reverse recovery before forced off, the high-side FET will experience a pulse of drain current turn on. The simultaneous presence of high drain-source voltage and high drain current in the high-side FET causes the switching loss. Apparently the switching loss is proportional to the PWM frequency. Having a Schottky diode in parallel with the low-side body diode will to a large extent alleviate the problem. This is because a Schottky diode does not undergo a reverse recovery and it has a lower forward voltage than the body diode so it will take the majority of the inductor current after the low-side FET is turned off. The low-side FET benefits from what is called zero voltage switching (ZVS). That is because every time just before the low-side FET is turned on, inductor current is already flowing in its body diode, resulting in a low drain-source voltage. When the low-side FET is turned off, current will be shifted to its body diode temporarily, again clamping the drain-source voltage to a low value.

It is difficult to calculate the switching loss due to its complicated nature. Fortunately at a reasonable PWM frequency such as 300 kHz, the switching loss is usually much less than the Ohmic loss. So the designer may initially ignore the switching loss when trying to meet an efficiency specification.

The Ohmic loss for the high-side FET is:

$$P_{FET1} = I_o^2 \cdot r_{DS_ON_1} \cdot D \quad (12)$$

The Ohmic loss for the low-side FET is:

$$P_{FET2} = I_o^2 \cdot r_{DS_ON_2} \cdot (1-D) \quad (13)$$

Notice when determining the r_{DS_ON} , the gate-source voltages are usually different for the two FET's. For the high-side FET, V_{GS} is V_{DD} minus drain voltage. For the low-side, V_{GS} is V_{DD} . This means the low-side FET may present a lower r_{DS_ON} when the same type of FET is used for both switches.

Since the r_{DS_ON} has a positive temperature coefficient, the actual Ohmic loss may be somewhat higher than calculated. The power supply designer may target 125°C FET operating temperature under maximum load and highest ambient temperature and then use the corresponding r_{DS_ON} found in the FET datasheet.

Linear Section—Two things need to be considered, i.e., r_{DS_ON} and thermal capacity. Make sure that the maximum possible r_{DS_ON} on the N-FET is lower than the lowest input-output differential voltage divided by maximum load current. In a typical motherboard 3.3V to 1.5V or 3.3V to 2.5V application, this is not an issue because the maximum allowable r_{DS_ON} is way higher than a typical N-FET. It is the thermal capacity and cost that limits the selection. As an example, consider a 3.3V to 1.5V, 4A application. The lowest input-output differential voltage is $3.3V \times 95\% - 1.5V \times 102\% = 1.605V$, so the maximum allowable r_{DS_ON} is $1.605V \div 4A = 401 \text{ m}\Omega$. Almost all low voltage discrete N-FET's can meet this requirement. However, the maximum power dissipation on the FET is $(3.3V \times 105\% - 1.5V \times 98\%) \times 4A = 8W$. At least a TO-220 package with a beefy heat sink is necessary to handle the thermal dissipation. When there is a load transient requirement such as that of the GTL+ supply, make sure the r_{DS_ON} is much lower than the value calculated from steady state operation because headroom is important for transient performance.

Capacitor Selection

Switching Section—

Output Capacitors. The selection of capacitors is an extremely important step when designing a converter for a load such as the MPU core. Since the typical slew rate of the load current during a large load transient is around 20 A/ μ s to 30 A/ μ s, the switching converter has to rely on the output capacitors to take care of the first few microseconds. Under such a current slew rate, ESR of the output capacitors is more of a concern than the ESL in terms of voltage excursion. Depending on the kind of capacitors being used, total output capacitance value may or may not be an important factor. When the output capacitance is too low, the converter may have to have a small output inductor to quickly supply current to the output capacitors when the load suddenly kicks in and to quickly stop supplying current when the load is suddenly removed. Multilayer ceramic (MLC) capacitors can have very low ESR but also a low capacitance value compared to other kinds of capacitors. Low ESR aluminum

electrolytic capacitors tend to have large sizes and capacitance. Tantalum electrolytic capacitors can have a fairly low ESR with a much smaller size and capacitance than the aluminum capacitors. Certain OSCON capacitors present ultra low ESR and long life span. By the time the total ESR of the output capacitor bank reaches around 9 mΩ, the capacitance of the aluminum/tantalum/OSCON capacitors is usually already in the millifarad range. For those capacitors, ESR is the only factor to consider. MLCs can have the same amount of total ESR with much less capacitance, most probably under 100 μF. A very small inductor, ultra fast control loop and a high switching frequency become necessary in such a case to deal with the fast charging/discharging rate of the output capacitor bank.

From a cost savings standpoint, aluminum electrolytic capacitors are the most popular choice for output capacitors. They have reasonably long life span and they tend to have high capacitance to withstand the charging or discharging process during a load transient for a fairly long period. Sanyo MV-GX and MV-DX series' give good performance when enough of the capacitors are paralleled. The 6MV1500GX capacitor has a typical ESR of 44 mΩ and a capacitance of 1500 μF at a voltage rating of 6.3V. For a detailed procedure for determining number of output capacitors, refer to the application note *Using Dynamic Voltage Positioning Technique to Reduce the Cost of Output Capacitors in Advanced Microprocessor Power Supplies* and the associated spreadsheet for automated design.

Input Capacitors. The challenge on input capacitors is the RMS ripple current. The large ripple current drawn by the high-side switch tends to generate quite some heat due to the capacitor ESR. The RMS ripple current ratings in the capacitor catalogs are usually specified under 105°C. In the case of desktop PC applications, those ratings seem somewhat conservative. A rule-of-thumb is increase the 105°C rating by 70% for desktop PC applications. The input RMS ripple current value can be determined by the following equation:

$$I_{\text{rms_rip}} = I_o \cdot \sqrt{D(1-D)} \quad (14)$$

and the power loss in each input capacitor is:

$$P_d = \frac{I_{\text{rms_rip}}^2 \times \text{ESR}}{n^2} \quad (15)$$

In the case of 333 MHz Pentium II power supply, the maximum output current is around 14A. Under the worst case when duty cycle is 50%, the maximum input capacitor RMS ripple current is half of output current, i.e., 7A. Therefore three Sanyo 16MV820GX capacitors are necessary under room temperature (they are rated 1.45A at 105°C). The maximum ESR of those capacitors is 44 mΩ. So the maximum power loss in each of them is less than $(7A)^2 \times 44 \text{ m}\Omega / 3^2 = 0.24W$. Note that the power loss in each capacitor is inversely proportional to the square of the total number of capacitors, which means the power loss in each capacitor quickly drops when the number of capacitors increases.

Linear Section—For applications where there is a load transient requirement such as that the GTL+ supply, low ESR capacitors should be considered. Make sure that the total ESR multiplied by the maximum load current is smaller than half the output voltage regulation window. The output voltage regulation window should exclude the tolerance of LM2637. For example, for a 3.3V to 1.5V, 2A design, the initial regulation window is ±9%. Assume the tolerance of the LM2637 plus margin is ±2%, then the effective window left is ±7% or ±105 mV. Therefore the ESR should be less than $105 \text{ mV} \div 2A = 52 \text{ m}\Omega$. A Sanyo 6MV1200DX is sufficient. For applications where the load is static and for control bandwidth and stability issue, refer to the guidelines in the *control loop compensation* section.

Inductor Selection

Output Inductor. The size of the output inductor is determined by a number of parameters. Basically the larger the inductor, the smaller the output ripple voltage, but the slower the converter's response speed during a load transient. On the other hand, a smaller inductor requires higher switching frequency to maintain the same level of output ripple, and probably results in a lossier converter, but has less inertia responding to load transient. In the case of MPU core power supply, fast recovery of the load voltage from transient window back to the steady state window is important. That limits the highest inductance value that can be used. The lowest inductance value is limited by the highest switching frequency that can be practically employed. As the switching frequency increases, the switching loss in the FETs tends to increase, resulting in lower overall efficiency and larger heat sinks. A good switching frequency is probably a frequency under which the FET conduction loss is much higher than the switching loss because the cost of the FET is directly related to its $r_{\text{DS_ON}}$. The inductor size can be determined by the following equation:

$$L = \frac{\text{ESR} \times V_o \cdot V_{\text{in}} - V_o}{V_{\text{o_rip}} \cdot f \times V_{\text{in}}} \quad (16)$$

where V_{o_rip} is the peak-peak output ripple voltage, f is the switching frequency. For commonly used low r_{DS_ON} FET's, a reasonable switching frequency is 300 kHz. Assume a peak-peak output ripple voltage is 18 mV, the total output capacitor ESR is 9 mΩ, the input voltage is 5V, and output voltage is 2.8V, then the inductance value according to the above equation will be 2 μH. The highest slew rate of the inductor current when the load changes from no load to full load can be determined as follows:

$$\frac{di_L}{dt} = \frac{V_{in} \cdot D_{max} - V_o}{L} \quad (17)$$

where D_{MAX} is the maximum allowed duty cycle, which is around 0.95 for LM2637. For a load transient from 0A to 14A, the highest current slew rate of the inductor, according to the above equation, is 0.97 A/μs, and therefore the shortest possible total recovery time is $14A/(0.97 \text{ A/}\mu\text{s}) = 14.5 \mu\text{s}$. Notice that output voltage starts to recover whenever the inductor starts to supply current.

The highest slew rate of the inductor current when the load changes from full load to no load can be determined from the same equation but use D_{MIN} instead of D_{MAX} .

Since the D_{MIN} of LM2637 is at 0%, the slew rate is therefore $-1.4 \text{ A/}\mu\text{s}$. So the approximate total recovery time will be $14A/(1.4 \text{ A/}\mu\text{s}) = 10 \mu\text{s}$.

Often times the power supply designer may have to use a custom-made inductor for best performance/price ratio. Micrometals offers cost effective iron powder cores that are widely adopted by motherboard supplies and OEMs. One important rule when designing an iron power inductor is never saturate the core or else it will exhibit extremely poor dynamic performance. Useful inductor design tools can also be found on their web page, www.micrometals.com. The user of LM2637 can also contact Texas Instruments for a custom-made inductor.

Alternatively the designer may use an open core inductor, which is lower cost due to its ease of mass production. However, the open magnetic field may cause some noise problems to nearby circuitry and may cause EMI issues. However, no negative reports have been heard so far. Coilcraft (www.coilcraft.com) offers a wide range of open core inductors. Custom-made parts are also possible. Other than low cost, the advantages of open core inductors are less board space and superior dynamic performance.

Input Inductor. The input inductor is for limiting the input current slew rate during a load transient and normal operation. In the case that low ESR aluminum electrolytic capacitors are used for the input capacitor bank, input capacitor voltage change due to capacitor charging/discharging is usually negligible for the first 20 μs. ESR is by far the dominant factor in determining the amount of capacitor voltage undershoot/overshoot during a fast load transient. So the worst case is when the load changes between no load and full load. Under that condition the input inductor sees the highest voltage change across the input capacitors. Assume the input capacitor bank consists of three 16MV820GX, i.e., a total ESR of 15 mΩ. Whenever there is a sudden load change, the change in input current has to be initially supported by the input capacitor bank instead of the input inductor. So for a fast load-swing between 0A and 14A, the voltage change seen by the input inductor is a ramp from 0V to a ΔV or vice versa, whereas $\Delta V = 14A \times 15 \text{ m}\Omega = 210 \text{ mV}$. So this situation is just as bad as operating under heaviest load. Use the following equation to determine the minimum inductance value:

$$L_{in} = \frac{\Delta V}{\left(\frac{di}{dt}\right)_{max}} \quad (18)$$

where $(di/dt)_{max}$ is the maximum allowable input current slew rate, which is 0.1 A/μs in the case of Pentium II power supply and ΔV is equal to maximum load current times input capacitor ESR. So the input inductor size, according to the above equation, should be 2.1 μH.

Dynamic Positioning of Load Voltage

The following is just a quick overview of a technique called dynamic voltage positioning. For a detailed explanation and examples please refer to our application note *Using Dynamic Voltage Positioning Technique to Reduce the Cost of Output Capacitors in Advanced Microprocessor Power Supplies*. An associated spreadsheet is also available for automated design.

Since the typical MPU core voltage's steady state regulation window is fairly large, it is a good idea to dynamically position the steady state output voltage in the steady state regulation window with respect to load current level so that the output voltage has more headroom for load transient response. This needs load current information. There are at least two simple ways to implement this idea with LM2637. One is to utilize the output inductor DC resistance, see [Figure 10](#). The average voltage across the output inductor is actually that across its DC resistance, which is proportional to load current.

Since the switching node voltage V_A toggles between the input voltage and ground at the switching frequency, it is impossible to choose node A as the feedback point, otherwise the dynamic performance will suffer and the system may have noise problems. Using a low pass filter network around the inductor, such as the one shown in the figure, seems to be a good idea. The feedback point is node C.

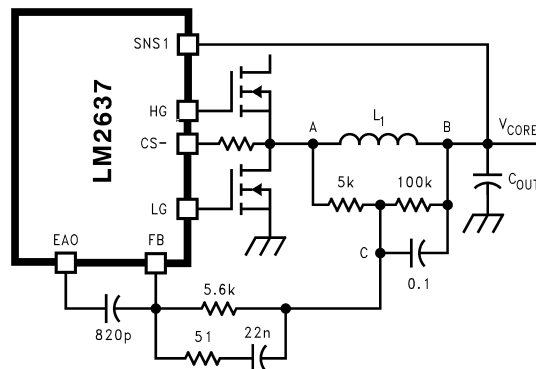

Figure 10. Dynamic Voltage Positioning by Utilizing Output Inductor DC Resistance

Since at switching frequency the impedance of the 0.1 μF is much less than 5 k Ω , so the toggling voltage at node A will mainly drop across the 5 k Ω resistor and node C will be much quieter than A. However, V_{CB} average is still the majority of V_{AB} average, because of the ratio of the resistor divider. So in steady state $V_C = I_O \times r_L + V_{CORE}$, where r_L is the inductor DC resistance. So at no load, output voltage is equal to V_C , and at full load, output voltage is $I_O \times r_L$ lower than V_C . To further utilize the steady state regulation window, a resistor can be connected between the FB pin and ground to increase the no-load output voltage to close to the upper limit of the window.

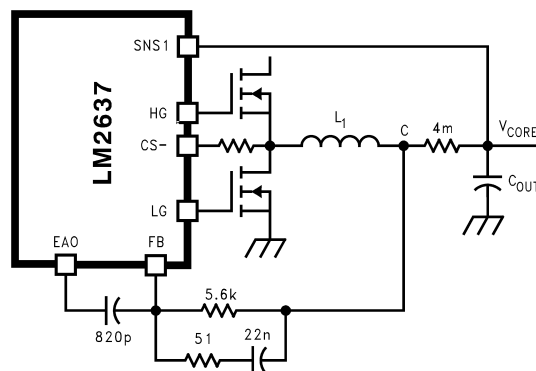

Figure 11. Dynamic Voltage Positioning by Using a Stand-Alone Resistor

A possible drawback of the scheme in Figure 10 is slow transient recovery speed. Since the 5 k Ω resistor and the 0.1 μF capacitor have a large time constant, the settling of node C to its steady state value during a load transient may take a few milliseconds. Depends on the interaction between the compensation network and the 0.1 μF capacitor, V_{CORE} may take different routes to reach its steady state value. This is undesired when the load transient happens more than 1000 times per second. Reducing the time constant will result in a more fluctuating V_C , due to a less effective low pass filter. Fine tuning the parameters may generate an acceptable design.

Another way to implement the dynamic voltage positioning is through the use of a separate resistor, such as the 4 m Ω resistor in Figure 11 above. The advantage of this implementation over the previous one is a much faster recovery speed of V_{CORE} from transient level to steady state level. A fine-tuned compensation network will give good response as shown in Figure 12. The disadvantage is additional power loss. The total power loss can be 0.78W at 14A of load current. The cost of the resistor can be minimized by using a PCB etch resistor.

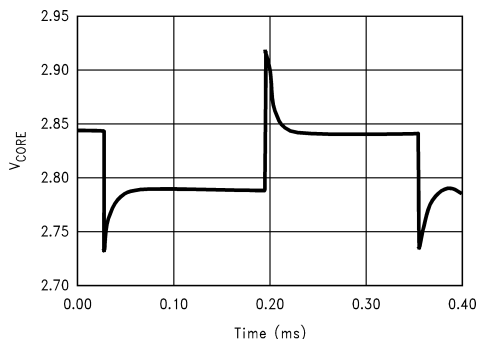

Figure 12. Load Transient Response with DVP: 0A to 14A, ESR = 9.4 m Ω , Droop Resistor = 4 m Ω

PCB Layout Considerations

There are several points to consider.

1. Try to use 2 oz. copper for the ground plane if tight load regulation is desired. In the case of dynamic voltage positioning, this may not be a concern because the loose load regulation is desired anyway. However, do not forget to take into consideration the voltage drop caused by the ground plane when calculating dynamic voltage positioning parameters.
2. Try to keep gate drive traces short. However, do not make them too short or else the LM2637 may be placed too close to the FETs and get heated up by them. For the same reason, do not use wide traces, 10 mil traces should be enough.
3. When not employing dynamic voltage positioning, place the feedback point at the VRM connector pins so as to have a tight load regulation. If it is an embedded power supply, place the feedback point at Slot I connector or wherever closest to the MPU.
4. Start component placement with the power devices such as FETs, and inductors.
5. Do not place the LM2637 directly underneath the FETs (on the other side of the PCB) when surface mount FETs are used. Also try to avoid staying too close to the output inductor, especially when using an open core inductor.
6. If possible, keep the capacitors some distance away from the inductors and FET heatsinks so that the capacitors will have a better thermal environment. Keep in mind that the input capacitors are usually much hotter than output capacitors.
7. When implementing dynamic voltage positioning through a PCB trace, keep in mind that the PCB trace is a heat source and try to avoid placing the trace directly underneath the LM2637.
8. Try to place a ceramic capacitor as close as possible to the V_{DD} pin.
9. If it is a MPU core supply, try to place the output bulk capacitors fairly close to the MPU for lower inductance.

IMPORTANT NOTICE

Texas Instruments Incorporated and its subsidiaries (TI) reserve the right to make corrections, enhancements, improvements and other changes to its semiconductor products and services per JESD46, latest issue, and to discontinue any product or service per JESD48, latest issue. Buyers should obtain the latest relevant information before placing orders and should verify that such information is current and complete. All semiconductor products (also referred to herein as "components") are sold subject to TI's terms and conditions of sale supplied at the time of order acknowledgment.

TI warrants performance of its components to the specifications applicable at the time of sale, in accordance with the warranty in TI's terms and conditions of sale of semiconductor products. Testing and other quality control techniques are used to the extent TI deems necessary to support this warranty. Except where mandated by applicable law, testing of all parameters of each component is not necessarily performed.

TI assumes no liability for applications assistance or the design of Buyers' products. Buyers are responsible for their products and applications using TI components. To minimize the risks associated with Buyers' products and applications, Buyers should provide adequate design and operating safeguards.

TI does not warrant or represent that any license, either express or implied, is granted under any patent right, copyright, mask work right, or other intellectual property right relating to any combination, machine, or process in which TI components or services are used. Information published by TI regarding third-party products or services does not constitute a license to use such products or services or a warranty or endorsement thereof. Use of such information may require a license from a third party under the patents or other intellectual property of the third party, or a license from TI under the patents or other intellectual property of TI.

Reproduction of significant portions of TI information in TI data books or data sheets is permissible only if reproduction is without alteration and is accompanied by all associated warranties, conditions, limitations, and notices. TI is not responsible or liable for such altered documentation. Information of third parties may be subject to additional restrictions.

Resale of TI components or services with statements different from or beyond the parameters stated by TI for that component or service voids all express and any implied warranties for the associated TI component or service and is an unfair and deceptive business practice. TI is not responsible or liable for any such statements.

Buyer acknowledges and agrees that it is solely responsible for compliance with all legal, regulatory and safety-related requirements concerning its products, and any use of TI components in its applications, notwithstanding any applications-related information or support that may be provided by TI. Buyer represents and agrees that it has all the necessary expertise to create and implement safeguards which anticipate dangerous consequences of failures, monitor failures and their consequences, lessen the likelihood of failures that might cause harm and take appropriate remedial actions. Buyer will fully indemnify TI and its representatives against any damages arising out of the use of any TI components in safety-critical applications.

In some cases, TI components may be promoted specifically to facilitate safety-related applications. With such components, TI's goal is to help enable customers to design and create their own end-product solutions that meet applicable functional safety standards and requirements. Nonetheless, such components are subject to these terms.

No TI components are authorized for use in FDA Class III (or similar life-critical medical equipment) unless authorized officers of the parties have executed a special agreement specifically governing such use.

Only those TI components which TI has specifically designated as military grade or "enhanced plastic" are designed and intended for use in military/aerospace applications or environments. Buyer acknowledges and agrees that any military or aerospace use of TI components which have **not** been so designated is solely at the Buyer's risk, and that Buyer is solely responsible for compliance with all legal and regulatory requirements in connection with such use.

TI has specifically designated certain components as meeting ISO/TS16949 requirements, mainly for automotive use. In any case of use of non-designated products, TI will not be responsible for any failure to meet ISO/TS16949.

Products

Audio	www.ti.com/audio
Amplifiers	amplifier.ti.com
Data Converters	dataconverter.ti.com
DLP® Products	www.dlp.com
DSP	dsp.ti.com
Clocks and Timers	www.ti.com/clocks
Interface	interface.ti.com
Logic	logic.ti.com
Power Mgmt	power.ti.com
Microcontrollers	microcontroller.ti.com
RFID	www.ti-rfid.com
OMAP Applications Processors	www.ti.com/omap
Wireless Connectivity	www.ti.com/wirelessconnectivity

Applications

Automotive and Transportation	www.ti.com/automotive
Communications and Telecom	www.ti.com/communications
Computers and Peripherals	www.ti.com/computers
Consumer Electronics	www.ti.com/consumer-apps
Energy and Lighting	www.ti.com/energy
Industrial	www.ti.com/industrial
Medical	www.ti.com/medical
Security	www.ti.com/security
Space, Avionics and Defense	www.ti.com/space-avionics-defense
Video and Imaging	www.ti.com/video

TI E2E Community

e2e.ti.com