

POWER DRIVE SERVICES

Electric Motor Control Specialists

Unit 1, Victoria St. Ind. Est. Victoria Street, LEIGH
Greater Manchester WN7 5SE U.K.
Tel +44 (0)1942 260206 Fax +44 (0)1942 260525
<http://www.inverter.co.uk> & www.softstart.co.uk

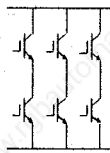

INSTRUCTION MANUAL

Converters

GYPACE

TPy3...4B

Converters for four-quadrant operation, without circulating current

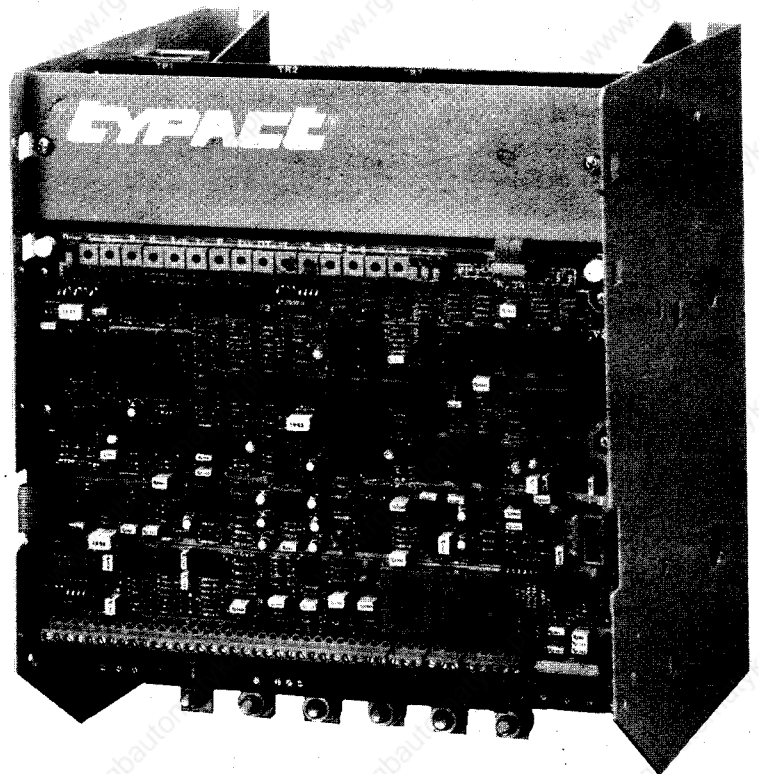
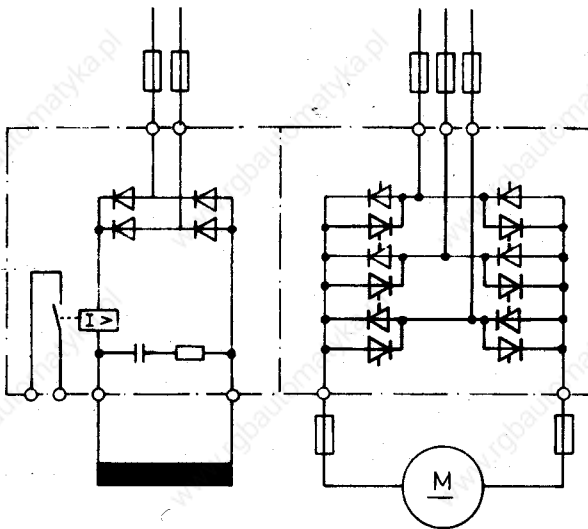

Contents

1.	General	333	6.3	Commissioning	363
2.	Technical data	333	6.3.1	Current limitation, EMF anticipatory control, R x I compensation, current indication	363
2.1	Mains connection	333	6.3.2	Rated motor speed, speed indication	364
2.2	Rated d.c. voltage	334	6.3.3	Minimum speed	364
2.3	Rated d.c. current	334	6.3.4	Ramp function generator	364
2.4	Field supply	336	6.3.5	Offset adjustment n-regulator	364
2.5	Fuses	336	6.3.6	Recognition of offset adjustment $n_{act} = 0$	364
2.5.1	Regulator supply	336	6.3.7	Recognition of offset adjustment $n_{ref} = 0$	365
2.5.2	Protective circuit	336	6.3.8	Stabilization of n-regulator	365
2.5.3	Power section	337	6.4.	Tuning	365
2.6	Ambient conditions	337	6.4.1	Current regulator	365
2.7	Regulation	338	6.4.1.1	Calibration with continuous current	366
2.7.1	Regulating range	338	6.4.1.2	Calibration with discontinuous current	367
2.7.2	Accuracy	338	6.4.1.3	Checking the overall setting	368
2.7.3	Actual value	338	6.4.2	Speed regulator	368
2.8	Dimensions	338	7.	Fault tracing	370
2.9	Weights and power losses	339	8.	Connectors	371
2.10	Cooling	340	8.1	Bus connection X for the connection of optional equipment	371
3.	Special features	340	8.2	J-Connector for interconnection with a 2Q-field controller	
4.	Fitting and electrical connections	340	9.	Test points available	372
4.1	Fitting	340	9.1	Regulator card Ry34	372
4.2	Electrical connections	341	9.2	Regulator supply Sy3	374
5.	Converter circuits	344	9.3	Modulator My34	374
5.1	Internal voltage supply	344	10.	Layout of the terminals	376
5.2	Enable	344	10.1	Regulator card Ry34	376
5.2.1	Regulator enable	344	10.2	Py34-... card	377
5.2.2	Enable ramp function generator	345	10.3	Armature circuit	377
5.2.3	Reference value enable	346	10.4	Field supply Fy...	378
5.3	Actual value circuit	346	11.	LED's	378
5.3.1	Tachometer regulation	347	11.1	Regulator card Ry34	378
5.3.2	Armature voltage regulation with high impedance decoupling	347	11.2	Modulator My34	378
5.3.3	Standstill monitoring	348	11.3	Field supply Fy30	378
5.3.4	Speed indication	348	12.	Potentiometer	379
5.4	Reference value circuit	349	12.1	Regulator card Ry34	379
5.4.1	Operation with ramp function generator	349	12.2	Card Py34-...	379
5.4.2	Operation without ramp function generator	351	13.	Micro switch	380
5.4.3	Minimum speed	351	13.1	Regulator card Ry34	380
5.4.4	External reference and correction values	351	13.2	Regulator supply Sy3	381
5.5	Current limitation	352	13.3	Modulator My34	381
5.5.1	Internal current limitation	352	13.4	Field supply Fy30	381
5.5.2	External current limitation	353	13.5	Switch positions as supplied	381
5.5.3	Current indication	353	14.	Bridges, calibration elements	382
5.6	Speed (n) - regulator	353	14.1	Regulator card Ry34	382
5.7	Current regulator	356	14.2	Py34-... card	382
5.8	Current regulation	357	14.3	Field supply Fy30	383
5.9	Changeover logic	359	15.	Schematic and circuit diagram	383
5.10	Control section	360			
5.11	Control circuits	362			
6.	Commissioning instructions	362			
6.1	Assembly test	362			
6.2	Checking the auxiliary voltage	363			

1. General

The power section of the TPY3...-4B range of d.c. converters consists of two fully-controlled three phase bridges in anti-parallel connection for four quadrant operation. This section supplies the necessary power to the armature of d.c. shunt wound motors of medium and high ratings. The E.M.F. anticipatory circuit monitors the changeover interval during which the direction of torque is reversed and no current flows. The result is a very short torquefree duration period. An uncontrolled Graetz bridge with protective circuit and field current relay is available for the field supply. The various cards of the regulator section are divided according to functions. They are connected to each other and to the power section via a ribbon-type cable.

— Ry34	ESE 1590	Regulator, actuating logic, LED displays, calibration components.
	(front card)	
— My34	ESE 1591	Modulator and synchronization.
— Sy3	ESE 1592	Regulator supply and voltage stabilization.
— PTy34	ESE 1604	Ignition circuits with pulse transformers.
— Py34-1	ESE 1603	} Clipper circuit, EMF trasducer resistors, SCR blocking sensor, } fuse monitoring for the power section.
— Py34-2	ESE 1634	
— Py34-0	ESE 1637	
— Fy...	ESE 1616	} Field rectifier with protective circuit and } field current relay.
	ESE 1638	

The two ranges, TPY3-415/440...-4B and TPY3-500/520...-4B differ in the voltage stability of their power sections. The regulator sections are identical. Converters up to a rated current of 600A are built as compact units. The power section is a separate unit, and is connected to the regulator section via plug-in connectors. Units from 110A rated current upward, are fan-cooled. See 2.8 for dimensions.

2. Technical data

2.1 Mains connection

Series TPY3...4B converters can be connected directly to the following mains systems:

Type	Mains system 50/60 Hz	
TPY3-415/440...-4B	3 × 230V —10% ... 240V +10%	→ Standard
	3 × 380V ±10%	
	3 × 415V ±10%	
TPY3-500/520... 4B	as above, additionally:	→ Standard
	3 × 440V —10% ... 460V +10%	
	3 × 480V —10% ... 500V +10%	

The converters are matched to the mains voltage via the switches SW-U, SW-V, SW-W on the Sy3 card. Only one circuit may be closed at any one time; the positions of the three switches must agree. The position of the switch SW6-2...4 on the My34 cards depends on the mains frequency.

f	SW6-1...4	
50Hz ±4%	OFF	→ Standard
60Hz ±4%	ON	

Power and regulating sections may be energised at the same time.

As supplied, the power units are connected to the controller via the bridges, CU-U, CU-V and CU-W on the Py34... card. It is however, recommended that the power and regulator sections are fed separately, so that the information provided by the LED and any possible fault indication via the relay is maintained, even if the motor is not switched on. In this case, CV-U, CV-V and CV-W on the Py34... should be removed. The regulator is then supplied via the terminals, 1U, 1V, 1W on Py34...

Common incoming supply

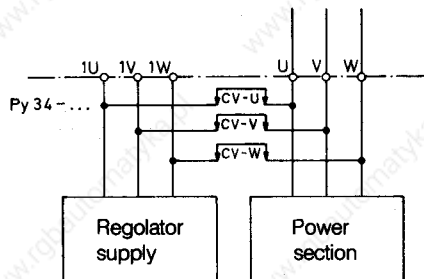

Fig. 2.1.1

Separate incoming supply

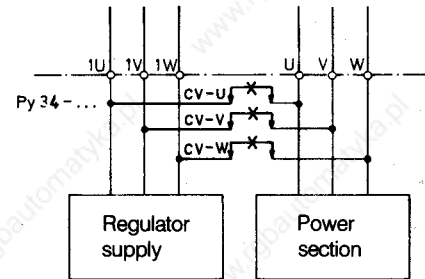

Fig. 2.1.2

The phase rotation must be the same as for the power section. The direction of the rotating field is as required. When a clockwise field is connected, the LED "UWV" on card My34 lights up.

2.2 Rated d.c. voltage

The magnitude of the rated d.c. voltage depends on the mains supply voltage.

U_{LN}	U_{dN}	Converter
3 × 220V	230V	TPy3-415/440- ... -4B
3 × 240V	250V	
3 × 380V	400V	
3 × 415V	440V	
3 × 440V	460V	TPy3-500/520- ... -4B
3 × 460V	480V	
3 × 480V	500V	
3 × 500V	520V	

2.3 Rated d.c. current

Type of converter	Rated d.c. current I_{dN}
TPy3-.../...- 20 -4B	20 A
TPy3-.../...- 40 -4B	40 A
TPy3-.../...- 70 -4B	70 A
TPy3-.../...- 110L-4B	110 A
TPy3-.../...- 140L-4B	140 A
TPy3-.../...- 185L-4B	185 A
TPy3-.../...- 280L-4B	280 A
TPy3-.../...- 350L-4B	350 A
TPy3-.../...- 420L-4B	420 A
TPy3-.../...- 600L-4B	600 A
TPy3-.../...- 800L-4B	800 A
TPy3-.../...-1000L-4B	1000 A
TPy3-.../...-1500L-4B	1500 A
TPy3-.../...-2000L-4B	2000 A

The current limiter is set ex-works to the rated d.c. current I_{dN} . The level of the maximum current can be reduced separately via the potentiometers "+ I_{dN} " and "- I_{dN} " for both the forward/reverse direction of rotation on the Ry34 card. If the maximum required armature current lies considerably below the d.c. rated current (less than the half) of the converter, we recommend adjustment in accordance with the table below. The calibration elements are located on the Py34-... card and are accessible from the front after fitting the regulator card (I_{max} = required maximum current value). Fine tuning is via potentiometers "TA" on the Py34-... card.

Converter		Standard	If required
TPy3 - ... / ... - 20 - 4B	R1	180 Ω	Remove R1 $R5 = \frac{4000 \text{ V}}{I_{max}} - 25 \text{ Ω} (\pm 25 \text{ Ω})$
	R2	not fitted	
	R3	not fitted	
	R4	not fitted	
	R5	not fitted	
TPy3 - ... / ... - 40 - 4B	R1	180 Ω	Remove R1 and R2 $R5 = \frac{4000 \text{ V}}{I_{max}} - 25 \text{ Ω} (\pm 25 \text{ Ω})$
	R2	180 Ω	
	R3	not fitted	
	R4	not fitted	
	R5	not fitted	
TPy3 - ... / ... - 70 - 4B	R1	not fitted	Remove R3 $R5 = \frac{4000 \text{ V}}{I_{max}} - 25 \text{ Ω} (\pm 25 \text{ Ω})$
	R2	not fitted	
	R3	47 Ω	
	R4	not fitted	
	R5	not fitted	
TPy3 - ... / ... - 110L - 4B	R1	180 Ω	Remove R1-R3 $R5 = \frac{4000 \text{ V}}{I_{max}} - 25 \text{ Ω} (\pm 25 \text{ Ω})$
	R2	180 Ω	
	R3	47 Ω	
	R4	not fitted	
	R5	not fitted	
TPy3 - ... / ... - 140L - 4B	R1	not fitted	Remove R3 and R4 $R5 = \frac{4000 \text{ V}}{I_{max}} - 25 \text{ Ω} (\pm 25 \text{ Ω})$
	R2	not fitted	
	R3	47 Ω	
	R4	47 Ω	
	R5	not fitted	
TPy3 - ... / ... - 185L - 4B	R1	180 Ω	Remove R1-R4 $R5 = \frac{4000 \text{ V}}{I_{max}} - 25 \text{ Ω} (\pm 25 \text{ Ω})$
	R2	180 Ω	
	R3	47 Ω	
	R4	47 Ω	
	R5	not fitted	
TPy3 - ... / ... - 280L - 4B	R1	not fitted	Remove R3, R4 $R5 = \frac{8000 \text{ V}}{I_{max}} - 5 \text{ Ω} (\pm 5 \text{ Ω})$
	R2	not fitted	
	R3	39 Ω	
	R4	39 Ω	
	R5	not fitted	
TPy3 - ... / ... - 350L - 4B	R1	not fitted	Remove R2-R4 $R5 = \frac{8000 \text{ V}}{I_{max}} - 5 \text{ Ω} (\pm 5 \text{ Ω})$
	R2	47 Ω	
	R3	39 Ω	
	R4	39 Ω	
	R5	not fitted	
TPy3 - ... / ... - 420L - 4B	R1	56 Ω	Remove R1-R3 $R5 = \frac{8000 \text{ V}}{I_{max}} - 5 \text{ Ω} (\pm 5 \text{ Ω})$
	R2	47 Ω	
	R3	39 Ω	
	R4	not fitted	
	R5	not fitted	
TPy3 - ... / ... - 500L - 4B	R1	56 Ω	Remove R1-R4 $R5 = \frac{8000 \text{ V}}{I_{max}} - 5 \text{ Ω} (\pm 5 \text{ Ω})$
	R2	47 Ω	
	R3	39 Ω	
	R4	39 Ω	
	R5	not fitted	

Converter		Standard	If required
TPy3 - ... / ... - 800L - 4B	R1	not fitted	Remove R1 + R2 $R^* = \frac{7750 \text{ V}}{I_{\text{max}}} - 5 \Omega (\pm 5 \Omega)$
	R2	not fitted	
	R3	13 Ω	
	R4	13 Ω	
TPy3 - ... / ... - 1000L - 4B	R1	not fitted	Remove R1 + R2 $R^* = \frac{7750 \text{ V}}{I_{\text{max}}} - 5 \Omega (\pm 5 \Omega)$
	R2	not fitted	
	R3	13 Ω	
	R4	13 Ω	
TPy3 - ... / ... - 1500L - 4B	R1	8,06 Ω	Remove R1 + R2 $R^* = \frac{7750 \text{ V}}{I_{\text{max}}} - 5 \Omega (\pm 5 \Omega)$
	R2	8,06 Ω	
	R3	not fitted	
	R4	not fitted	
TPy3 - ... / ... - 2000L - 4B	R1	8,06 Ω	Remove R1 + R2 $R^* = \frac{7750 \text{ V}}{I_{\text{max}}} - 5 \Omega (\pm 5 \Omega)$
	R2	8,06 Ω	
	R3	13 Ω	
	R4	not fitted	

R^* = resistor 1/2 W instead of R1 or R2 or R3 or R4.

2.4 Field supply

An uncontrolled d.c. rectifier with protective circuit is available for connection of the motor field.

- Max supply voltage : $U_{LN} = 415 \text{ V c.a.}$
- D.C. voltage output : $U_f = 0,9 U_{LN}$
- Max. field current : $I_f = 4 \text{ A}$ for TPy3-.../...- 20 ... 70 -4B
 $= 10 \text{ A}$ for TPy3-.../...- 110L... 500L-4B
 $= 25 \text{ A}$ for TPy3-.../...- 800L...2000L-4B

When the field current is flowing, the contact (250 V, 3 A, AC-11) between the terminals 53 and 54 on card Fy... is closed.

In the TPy3-.../...-800L...2000L-4B the card Fy-30 carries the field current adaptation.

I_f	Switch	Resistances
15 ... 25 A	> 15 A	R1 + R2
7,5 ... 15 A	$\leq 15 \text{ A}$	R1 + R2
< 7,5 A	$\leq 15 \text{ A}$	R2 (Remove R1)

2.5 Fuses

If a fuse blows, this is recognized and indicated. See 5.11.

2.5.1 Regulator supply

- A.C. side = F7, F8, F9 on Sy3
3 off L 1055/0.25 (6 x 32 mm; 250 mA superfast)
- D.C. side = F1, F2 on Sy3
2 off FF 19230/1,6 (5 x 20 mm; 1,6 A superfast)

2.5.2 Protective circuit

- F11, F12, F13 on Py34-...
3 off Navy/Omega (6 x 32 mm; 4 A fast, 500V)

2.5.3 Power section

Code A Armature circuit, a.c. side, external
Code B Armature circuit d.c. side, external

Code C Armature circuit, internal
Code D Field circuit, external

Converter	Code	No.	EUROPA Jean Müller	USA Gould Shawmut	USA Bussmann
TPy3 - ... / ... - 20 - 4B	A	3	gRD2/20	A70P 25	FWP 25
	B	2	gRD2/25	A70P 25	FWP 25
	D	2	gRD2/ 6	A60X5	FWP 5 (FWH 5)
TPy3 - ... / ... - 40 - 4B	A	3	gRD3/35	A70P 40	FWP 40
	B	2	gRD3/50	A70P 50	FWP 50
	D	2	gRD2/ 6	A60X5	FWP 5 (FWH 5)
TPy3 - ... / ... - 70 - 4B	A	3	gRD3/63	A70P 80	FWP 80
	B	2	S00üf1/80/80A/660V	A70P 80	FWP 80
	D	2	gRD2/ 6	A60X5	FWP 5 (FWH 5)
TPy3 - ... / ... - 110L - 4B	A	3	S00üf1/80/100A/660V	A70P 100	FWP 100
	B	2	S00üf1/80/125A/660V	A70P 150	FWP 150
	D	2	gRD2/16	A60X15	FWP 15 (FWH 15)
TPy3 - ... / ... - 140L - 4B	A	3	S00üf1/80/125A/660V	A70P 150	FWP 150
	B	2	S00üf1/80/160A/660V	A70P 175	FWP 175
	D	2	gRD2/16	A60X15	FWP 15 (FWH 15)
TPy3 - ... / ... - 185L - 4B	A	3	S00üf1/80/200A/660V	A70P 175	FWP 175
	B	2	S00üf1/80/200A/660V	A70P 200	FWP 200
	D	2	gRD2/16	A60X15	FWP 15 (FWH 15)
TPy3 - ... / ... - 280L - 4B	A	3	S1üf1/110/250A/660V	A70P 300	FWP 300
	B	2	S1üf1/110/315A/660V	A70P 350	FWP 350
	D	2	gRD2/16	A60X15	FWP 15 (FWH 15)
TPy3 - ... / ... - 350L - 4B	A	3	S1üf1/110/315A/660V	A70P 350	FWP 350
	B	2	S2üf1/110/400A/660V	A70P 400	FWP 400
	D	2	gRD2/16	A60X15	FWP 15 (FWH 15)
TPy3 - ... / ... - 420L - 4B	A	3	S2üf1/110/400A/660V	A70P 400	FWP 400
	B	2	S2üf1/110/500A/660V	A70P 500	FWP 500
	D	2	gRD2/16	A60X15	FWP 15 (FWH 15)
TPy3 - ... / ... - 500L - 4B	A	3	S2üf1/110/500A/660V	A70P 500	FWP 500
	B	2	S2üf1/110/630A/660V	A70P 600	FWP 600
	D	2	gRD2/16	A60X15	FWP 15 (FWH 15)
TPy3 - ... / ... - 800L - 4B	C	6	170L 8497 (500A)	—	—
	D	2	gRD2/30	—	—
TPy3 - ... / ... - 1000L - 4B	C	6	170L 8497 (700A)	—	—
	D	2	gRD2/30	—	—
TPy3 - ... / ... - 1500L - 4B	C	6	170L 7696 (1000A)	—	—
	D	2	gRD2/30	—	—
TPy3 - ... / ... - 2000L - 4B	C	12	170L 7074 (2 x 700A)	—	—
	D	2	gRD2/30	—	—

üf = superfast

2.6 Ambient conditions

Operating temperature : 0-40°C, or up to 55°C provided I_d is reduced by 1.25% per Kelvin temperature increase.

Storage temperature : -15°C... +65°C.

Altitude : Up to 1000 m above sea level. (Above this I_d must be reduced by 1.2% per 100 m.

Climate : In accordance with DIN 40 046 sheet 5.

2.7 Regulation

- Speed regulation with subordinate current regulation
 - a) Constant torque in the armature range
 - b) Constant output in the field range in conjunction with the field current converter
- Facility for torque regulation (current regulation)

2.7.1 Regulating range

Tachometer regulation : 1:1000 (typically)

Armature voltage regulation : 1:20 (typically)

Use of the APSy speed regulation adapter is recommended where very wide regulating ranges are involved. This can be fitted on the back of the Ry34 regulator card.

2.7.2 Accuracy

Tachometer regulation : $\pm 0,001\%$ in relation to n_{max} when changing from idling to full load
 : $\pm 0,07\%$ in relation to n_{act} with mains voltage fluctuations of $\pm 10\%$
 : $\pm 0,2\%$ in relation to n_{act} with temperature fluctuations of $\pm 10^\circ K$

Armature voltage regulation : The above data are still valid, but then relate to the armature voltage and not the speed. Experience has shown the speed error to be approximately $\pm 2\% n_{max}$ and is largely dependent on the technical data of the motor.

2.7.3 Actual value

- Speed : — Voltage from d.c. voltage tachometer
 — Armature voltage with high-impedance decoupling of power and regulator section via internal differential amplifiers with $R_x I$ compensation.
- Current : — Internal via converters on the a.c. side.

2.8 Dimensions

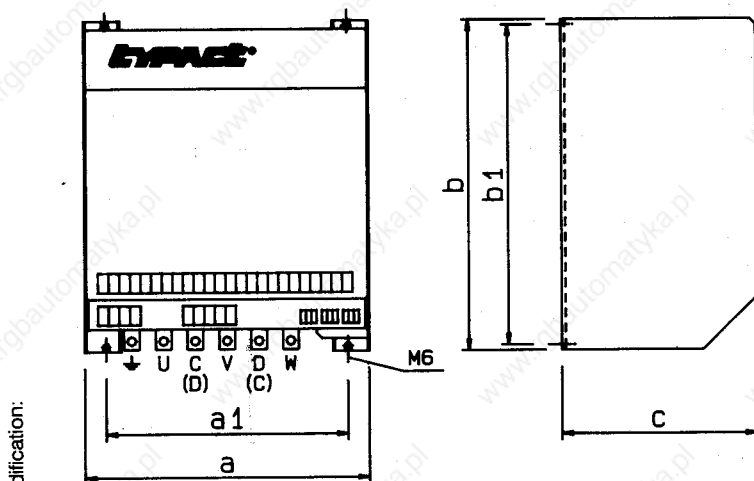

Modification:

Device rated current $I_{dN}(A)$	External dimensions (mm)			Fixing dimensions (mm)	
	Width a	Height x b	Depth x c	a1	b1
20	268	312	156	225	300
40	268	312	192	225	300
70	268	312	260	225	300
110	268	312	260	225	300
140	268	312	260	225	300
185	268	312	260	225	300
280	308	340	293	275	325
350	308	340	293	275	325
420	308	340	293	275	325
500	308	340	293	275	325

Fig. 2.8.1

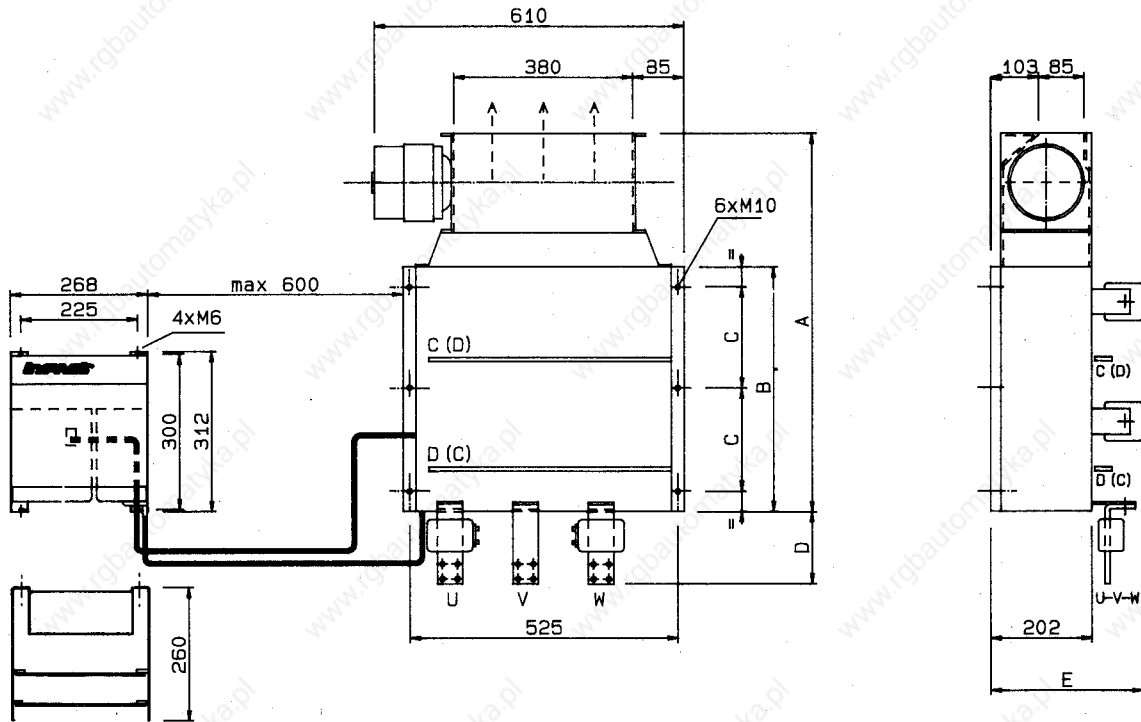

Rated current of the device I_{dN} (A)	A (mm)	B (mm)	C (mm)	D (mm)	E (mm)
800	740	480	200	125	310
1000	740	480	200	125	310
1500	965	700	300	145	333
2000	965	700	300	145	333

2.9 Weights and power losses

Rated current of the device I_{dN} (A)	Weight (kg)	Max. power losses (W) at $U_{LN} =$		
		230V (220/240)	415V (380)	500V (440/460/480)
20	10,7	94	122	113
40	11,0	153	186	177
70	11,8	210	238	229
110	13,5	390	419	427
140	13,5	463	492	500
185	13,5	549	578	586
280	27,0	886	915	923
350	27,0	1100	1129	1137
420	29,5	1149	1178	1186
500	29,5	1249	1278	1286
800	76/10,8	2841/68	2886/68	2915/68
1000	76/10,8	3668/68	3713/68	3742/68
1500	125/11,0	5216/68	5287/68	5334/68
2000	125/11,0	5582/68	5653/68	5700/68

Details for devices ≥ 800 A: power section/regulator section + field supply.

2.10 Cooling

Rated current of the device I_{dN} (A)	Fan data		
	Throughput (m ³ /h)	Mains voltage single phase (V)	Rated current (A)
20 ... 70	—	—	—
110 ... 185	160	220/240V, 50/60 Hz	0,12
280 ... 500	320	220/240V, 50/60 Hz	0,24
800 ... 2000	1590	220V, 50 Hz*	2,3

* 230/240V and/or 60 Hz, please enquire.

3. Special features

- LED indication for supply voltage, enable, current limitation and faults
- Collective fault indication via potential-free contacts and static signal 0 V or +24 V
- Micro switches for easy matching and commissioning (see 13)
- Regulator can be enabled from PLC without coupling section (+15 V... +24 V)
- Internal, high impedance decoupling of power and regulator section during armature voltage regulation
- Mounting facility for up to four supplementary cards on the back of the Ry34 regulator card
- Internal connections via ribbon-type cables and plugs (see 8)
- n = 0 indication via potential-free contact and static signal 0 V/+24 V
- Voltage supply is not dependent on direction of field current
- Speed regulator with PID characteristics
- EMF anticipator control = short changeover time during torque changes

4. Fitting and electrical connections

4.1 Fitting

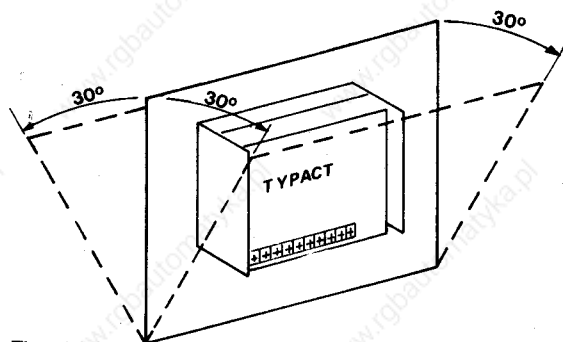
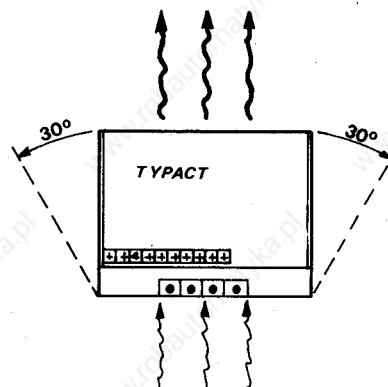

Fig. 4.1.1



Devices with high heat losses should not be mounted below the converter. After a few days operation the screws of the terminal strips should be tightened. Maximum angle of inclination $\pm 30^\circ$

4.2 Electrical connections

The converter is connected as shown in fig. 4.2.2. Fuses as detailed in Section 2.5.3 should be provided for the protection of the thyristors and the field d.c. rectifier. If the power and regulating sections are fed separately, the bridges CV-U, CV-V and CV-W should be removed from the Py34-... card.

The overload relay is fitted on the mains supply side and should be set to $0.82 \times I_{dN} \times F$.

I_{dN} = motor rated current (arithmetic mean)

F = form factor permitted by the motor manufacturer.

All the wires connected to the regulator section (with the exception of the potential-free contacts) should be screened, one end being connected to the regulator reference point, the other being isolated by means of a sleeve. Where multi-core screened cables are used, one cable should not carry more than one function (for example reference value or actual value or enable). The wiring in lengthy connections should be twisted.

If the wiring to the regulator section is laid in the same channel as the power and control section wiring, it is recommended that an RC link be provided in parallel with the individual contactor coils.

The terminals are suitable for cables without ferrules. In order to minimise reactive effects in the mains, and mutual interference between converters, VDE 0160, part 2 recommends the use of mains chokes with a relative short-circuit voltage $U_k = 4\%$ (L1 in Fig. 4.2.2).

In most cases, the armature circuit does not require a smoothing choke, but this should always be checked, bearing in mind the maximum permissible form factor of the motor and the armature inductance.

Note: During electrical braking, power is fed back into the mains system. The braking action must not be interrupted by the opening of the K1M mains contactor, since the thyristor commutation is then no longer controlled by the mains, and fuses may blow. There are only two occasions on which K1M may be de-energized:

1. When $n = 0$ (indication via relay contact between terminals 33 and 34 or static signal on terminal 32 = 0 V)
2. After prior regulator blocking (No voltage at terminal 21).

Modification:

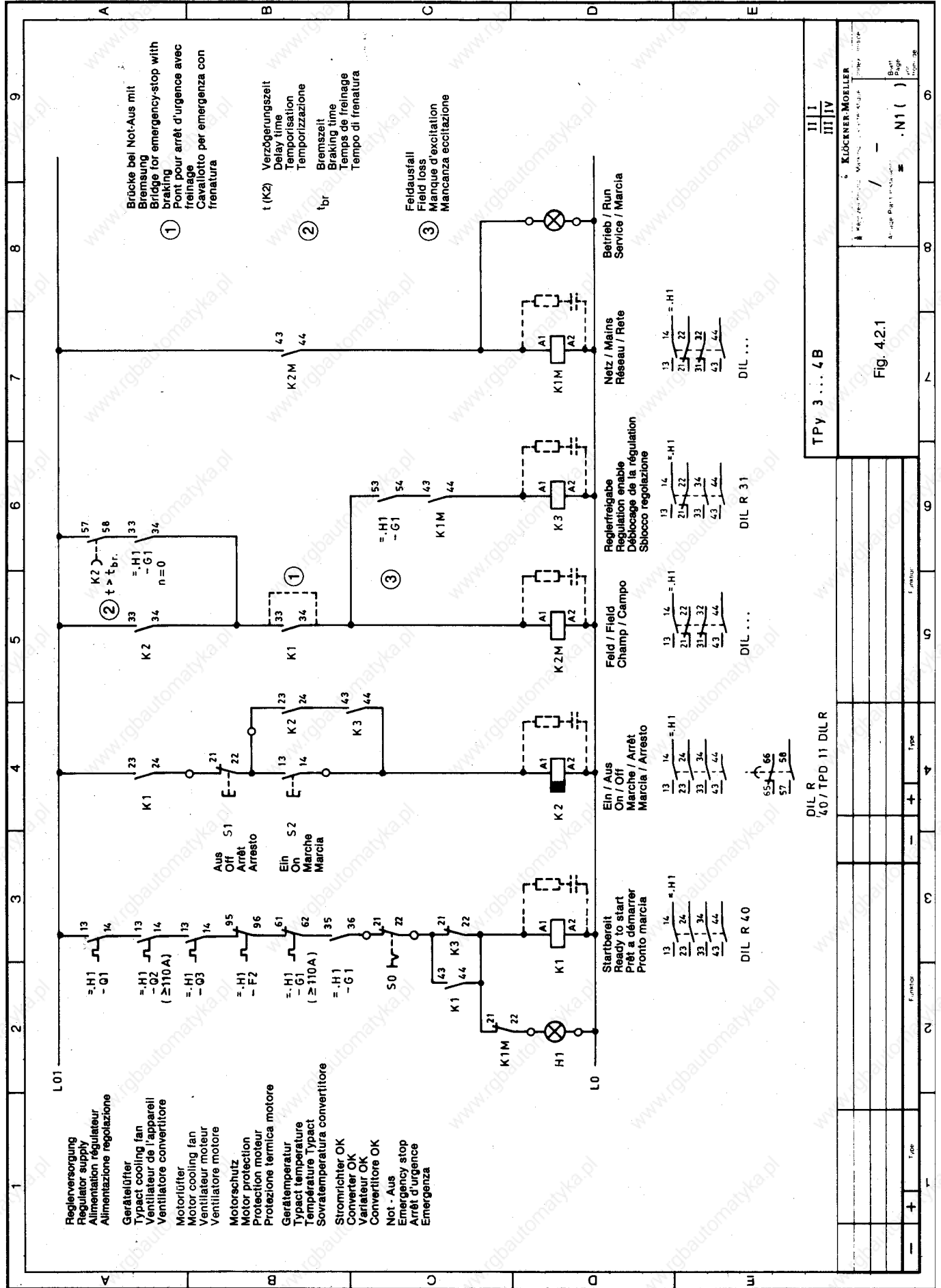

5. Converter circuits

5.1. Internal voltage supply

The voltage supply is on the Sy3 card. The mains supply unit consists of three single-phase transformers of 14 VA each. The primary windings are delta-connected, and are matched to mains voltage by means of switches SW-U, SW-V and SW-W (see 2.1). One of the three secondary windings at a time supplies the synchronisation voltage for the modulator (55 V a.c.), the other two supplying two three-phase bridges for generation of the regulator supply voltages. For fusing, see 2.5.1.

Voltage available

- $\pm 10V \pm 5\%$ Highly stabilized, short-circuit proof
maximum residual ripple: 3 mVpp
Thermal stability: ≤ 100 ppm/°C
Symmetry tolerance: $\leq 10\%$
In the event of a short-circuit, LED "RSH" lights up
- $\pm 15V \pm 4\%$ Stabilized, short-circuit proof
maximum residual ripple: 5 mVpp
In the event of an overload, LED "AR" lights up
- +24V Unstabilized
Tolerance +19...+28 V, depending on mains voltage and load
maximum residual ripple: 50 mVpp

Voltage	Termination	Add. load capacity
0V = Reference potential	terminals 2, 8, 0V Bus X 8, 10	
+10V	terminals 3, 31*	50 mA
-10V	terminals 4, 22**	50 mA
+15V	terminals +15 Bus X 16	200 mA - I ₊₁₀
-15V	terminals -15 Bus X 9	200 mA - I ₋₁₀
+24V	terminals 19, +24 Bus X 1	200 mA - I ₊₁₅ - I ₊₁₀

* With R217 = bridge ** With R218 = bridge

The load capacity as stated in the table relates to unloaded output terminals of the converter, and a mains undervoltage of 10% in relation to the rated value of the converter supply voltage.

5.2 Enable

Enablement is through application of a voltage of +15 ... +24 V to the appropriate terminals. The inputs are protected against polarity reversal. Negative voltage, 0 V and missing signal are interpreted as "blocking".

5.2.1 Regulator enable

Connection: Terminal 21 (\overline{BLG})

If the regulator is blocked, the LED "BLG" lights up.

There are several enable possibilities:

1. Bridge between +24 V (terminal 19) and terminal 21 (see fig. 5.2.1.2). This is possible only if voltage is applied simultaneously to the power and regulator section. The regulator is enabled approximately 200 ms after switching on, thus allowing the supply voltages to build up.

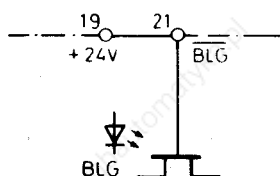

Fig. 5.2.1.1

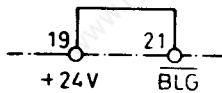

Fig. 5.2.1.2

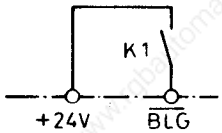

Fig. 5.2.1.3

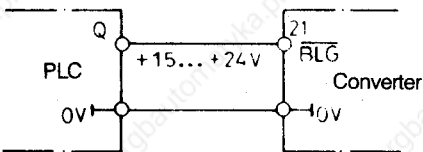
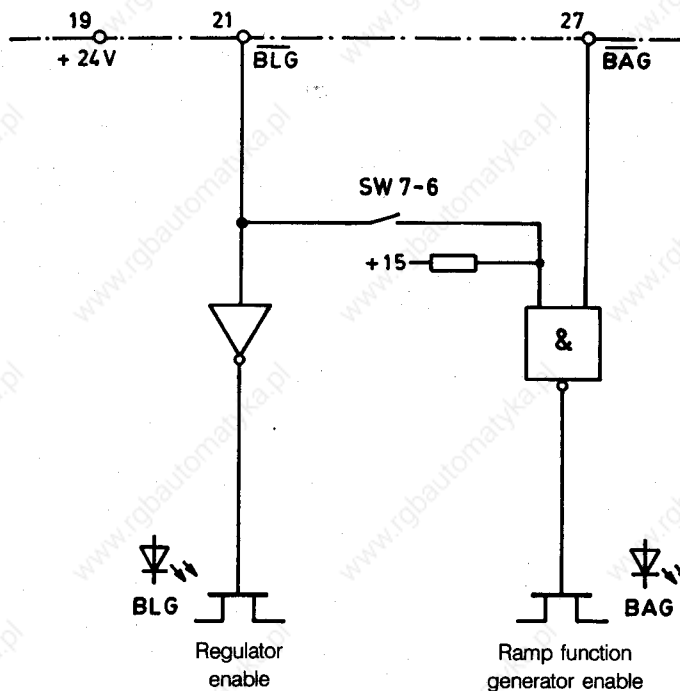

Fig. 5.2.1.4

2. Enable via contact.
 (See Fig. 5.2.1.3) Regulator enable without delay by closing the contact of K1. The contacts must not be closed before voltage is applied to the power section (Terminals U, V and W). The regulator is blocked when the contacts are opened.

3. Enable with programmable controller.
 (See Fig. 5.2.1.4) A voltage of +15 V... +24 V applied to terminal 21 enables the regulator. 0 V of PC and the converter are interconnected. Enable conditions are the same as in 2.

5.2.2 Enable ramp function generator



If the internal reference value generator is used, it must be enabled via terminal 27 (BAG). When the r.f. generator is blocked, the LED "BAG" lights up.

As supplied, the r.f. generator enable is coupled to the regulator enable (SW7-6 = ON), i.e., generator enable only with voltage at terminal 21 and 27 (see Fig. 5.2.2.1). If an independent generator enable is required, the SW7-6 should be switched to the OFF position.

Enable facilities as under 5.2.1).

L = block
 H = enable

Fig. 5.2.2.1

5.3.1 Tachometer regulation

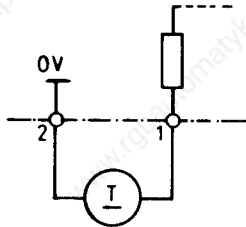

Fig. 5.3.1.1

- Connection as in Fig. 5.3.1.1
- Matching to the tachometer voltage as in table 13.1
- A d.c. tachometer should be used, which will change the polarity of the voltage output when the direction of rotation is changed.

5.3.2 Armature voltage regulation with high-impedance decoupling

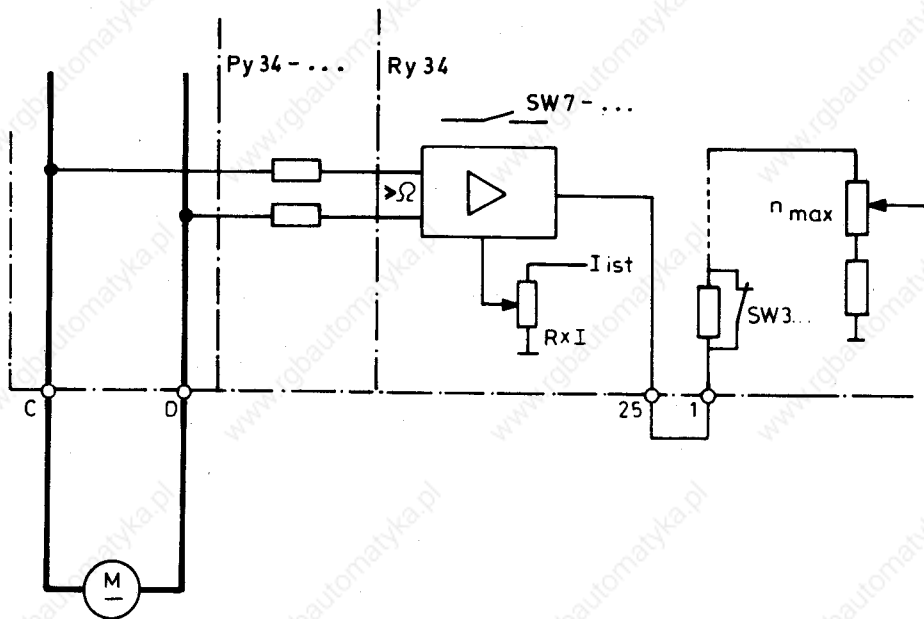

Fig. 5.3.2.1.

- Connection as in Fig. 5.3.2.1
- SW3-1...8 in the ON position
- Matching to the mains voltage with SW7 in accordance with the table overleaf.

The armature voltage is fed back to the actual value input via high-impedance resistors and a differential amplifier. By this means, the regulator sections can be decoupled without the need for d.c./d.c. transformers or multi-couplers.

After the signal has been filtered and decoupled, the actual value signal is available as a voltage between 0 and 10 V (Terminal 25). This signal and the actual value input are connected via an external bridge between terminal 25 and 1.

During armature voltage regulation, the motor speed at a constant armature voltage decreases as the load increases. This load-dependent decrease of the speed is reduced by means of the built-in RxI compensation (potentiometer RxI). This compensation calibration is described in item 6.3.1.

Matching of the decoupling amplifier:

U_{LN}			$Q_{EN} = 10 \text{ V at } U_{dN} = *$	
230/240 V	AC	SW7-1	267 V	DC
380 V	AC	SW7-2	429 V	DC
415 V	AC	SW7-3	467 V	DC
440/460 V	AC	SW7-4	508 V	DC
480/500 V	AC	SW7-5	553 V	DC

* R_{X1} compensation not taken into account.

The position of the SW7 depends on the mains voltage U_{LN} . Only one circuit of SW7 may be closed. The amplifier may also be matched to other mains voltage (for example from an ancillary transformer). In this case SW7-1...5 should be switched to the OFF position, and R90 fitted.

Rating:

$$R90 = 10 \text{ k}\Omega \left(\frac{490 \text{ V}}{U_{LN}} - 1 \right)$$

U_{LN} = Voltage at terminals U, V, W.

5.3.3 Standstill monitoring

When the motor is rotating (= actual value existing) the potential-free make-contact of the relay between terminals 33 and 34 is closed (220 V a.c., 3 A) and a signal of +24 V (load capacity 10 mA) is present at terminal 3

When the motor is stationary:

- RL1 drops out
- OV at terminal 32
- LED "n = 0" lights up

The switching point can be set between 0.5 and 3.5% using potentiometer "n = 0" on card Ry34.

The standstill indication is delayed, the delay-time τ being determined by the resistor R180:

$$\tau = 1,35 \cdot R180 \text{ (ms)} \quad R180 \text{ (kohm)} \quad (\text{standard } R180 = 47 \text{ kohm} = 65 \text{ ms})$$

5.3.4 Speed indication

A signal, directly proportional to the actual value, available at terminal 14 of the converter for connection of a speed indicator. The polarity of terminal 14 corresponds to that of terminal 1

SW5-1 ON: Voltage signal 0 ... approx. $\pm 10 \text{ V}$ ma on terminal 14, load capacity: 4 mA

SW5-1 OFF: Connection of an mA meter with 1 mA full-scale deflection.

The deflection of the pointer at n_{\max} can be calibrated using potentiometer DT_N .
Scale in rpm, m/s. %...

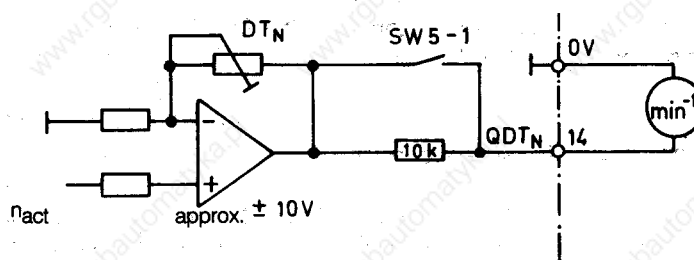

Fig. 5.3.4.1

5.4 Reference value circuit

The magnitude of the reference value voltage determines the speed of the motor under control.

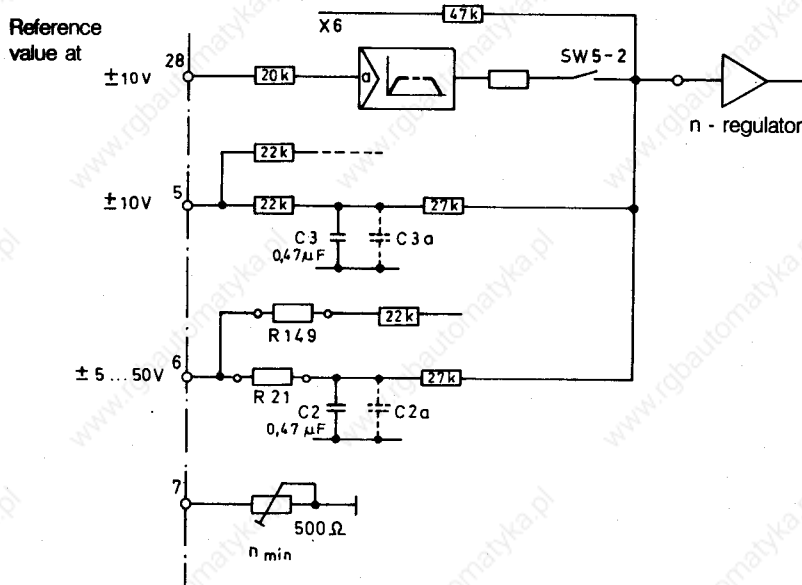

Fig. 5.4.1

If the circuit is connected as in Fig. 4.2.2, the result is as follows:
 Reference value + = clockwise rotation
 Reference value - = anti-clockwise rotation

5.4.1 Operation with ramp function generator

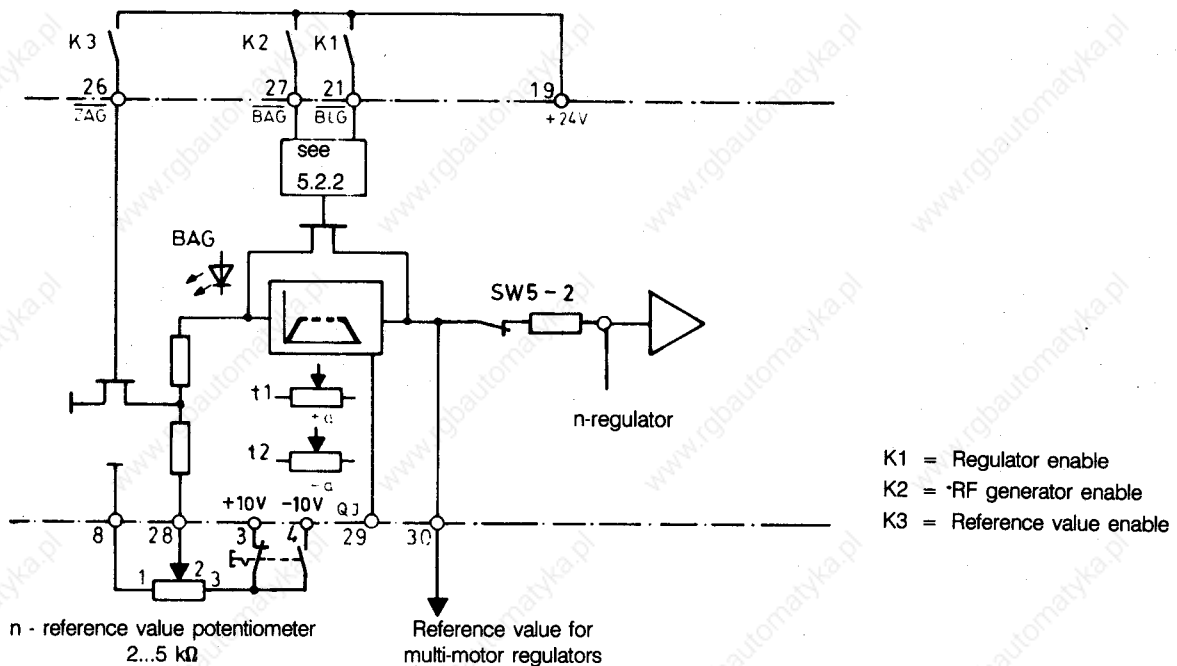

Fig. 5.4.1.1.

The ramp function generator is used to delay changes in the reference value voltage and thus to achieve run-up and run-down processes of predetermined duration. Wiring is in accordance with Fig. 5.4.1.1.

Input : Terminal 28 ± 10 V max, 0,5 mA max

Output : Terminal 30 ± 10 V max, 3 mA max (+ internal reference value input via SW5-2).

On the converter as supplied, the ramp function generator output is connected to the input of the speed regula via SW5-2.

The ramp function generator has two ramps, which can be adjusted separately.

Potentiometer "+a" (t_1) → run-up time during clockwise rotation, braking time during anti-clockwise rotation

Resistors R141 A, B, C

Potentiometer "-a" (t_2) → run-up time during anti-clockwise rotation, braking time during clockwise rotation

Resistors R142 A, B, C

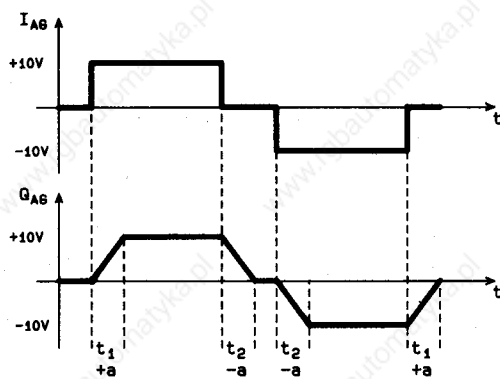

	STANDARD		NO STANDARD	
	t_1 0,5...5s	t_2 5s	t_1 3...30s	t_2 15...150s
R141a = 4.7M Ω R142a = 4.7M Ω	<input type="checkbox"/>	<input type="checkbox"/>	<input type="checkbox"/>	<input type="checkbox"/>
R141b = 1.2M Ω R142b = 1.2M Ω	<input type="checkbox"/>	<input type="checkbox"/>	<input checked="" type="checkbox"/>	<input checked="" type="checkbox"/>
R141c = 220K Ω R142c = 220K Ω	<input type="checkbox"/>	<input type="checkbox"/>	<input checked="" type="checkbox"/>	<input checked="" type="checkbox"/>

Fig. 5.4.1.2

The integration time is determined by the resistors R141 A, B, C, R142 A, B, C and the position of the potentiometers "+a" and "-a".

The various time ranges are achieved by removing resistors which are fitted as standard. If an external setting facility for the run-up time is required, use the AGy supplementary card. This can be fitted internally on the back of the Ry34 regulator card.

Mode of operation	Enable voltage on terminals	Function
Run-up operation	21, 26, 27	Motor runs up to set speed at pre-set rate of acceleration, speed changes are time-controlled.
Controlled run-down	21, 27	Motor runs down to "0" speed at pre-set rate.
Braking with max torque	21 possibly 26	Motor brakes to "0" speed at maximum torque.
Uncontrolled run-down	—	The motor decelerates naturally, the time being determined by rotating mass, friction and the speed at the moment of switching off.

For enable facilities, see 5.2.

During transition processes (speed changes) a voltage signal for the actuation of inertia compensation for shunt wound motors is available at terminal 29.

Clockwise acceleration or anti-clockwise braking
 Anti-clockwise acceleration or clockwise braking

- approx. -10 V , 3 mA max.
- approx. $+10\text{ V}$, 3 mA max.

5.4.2 Operation without ramp function generator

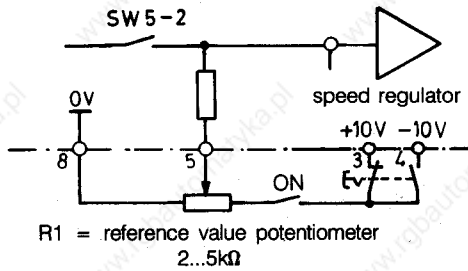

Fig. 5.4.2.1

- Connection as in Fig. 5.4.2.1.
- SW5-2 in the OFF position.
- Reference value input: $\pm 10\text{ V}$ max, 0,65 mA max. (terminal 5)

The motor speed follows the setting on the potentiometer.

Transition times from one speed to another during reference value changes are determined by the set current-limitation and the motor load. Terminal 6 is available for reference and correction values from external source (see 5.4.4).

5.4.3 Minimum speed

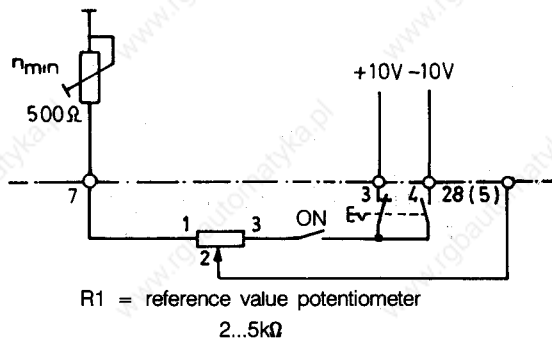

Fig. 5.4.3.1

- Connect circuit as in Fig. 5.4.3.1.
- Turn reference potentiometer R1 fully anti-clockwise
- Minimum speed is set by potentiometer "n_{min}" on card Ry34.

$$R1 = 2k\Omega : n_{\min} \leq 20\% n_{\max}$$

$$R1 = 5k\Omega : n_{\min} \leq 9\% n_{\max}$$

5.4.4 External reference and correction values

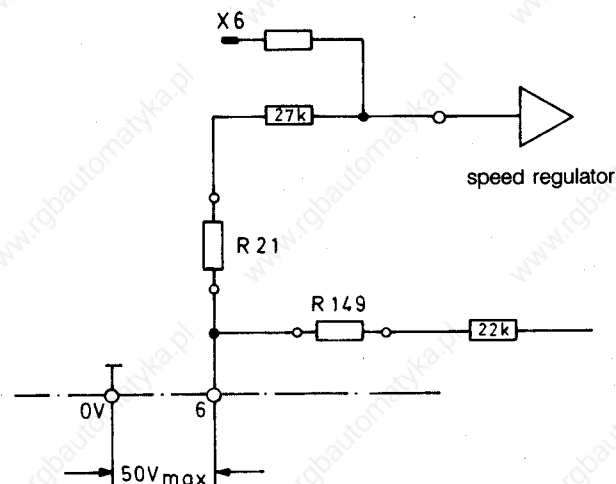

Fig. 5.4.4.1

The influence of the voltage on terminal 6 is determined by R21, which is located on solder terminals and, supplied, has a resistance of 22 kΩ, which corresponds to a maximum external input reference value of 10 V. On any other applications R21 has to be exchanged and rated in accordance with the formulae below.

Please note: When using terminal 6 and the required speed regulator matching, R149 must be rated accordingly (see 5.6).

Max. load of the external voltage source: 0.65 mA.

1. External reference values

Input matching is via R21

Rating:

$$R21 = \frac{U_{6max}}{0,2 \text{ mA}} - 27 \text{ k}\Omega \quad (1/4 \text{ Watt})$$

2. Correction values

Rating depends on the degree to which the correction value is to influence the reference value. The correction figure, as a percentage of the speed, is to be inserted in the following formula:

$$R21 = \frac{U_{6max} \cdot 100}{0,2 \text{ mA} \cdot \dots\%} - 27 \text{ k}\Omega \quad (1/4 \text{ Watt})$$

3. If the reference or correction value comes from an internal supplementary card, it is switched to the speed regulator input via bus X 6. No external connection is necessary to terminal 6.

5.5 Current limitation

The current limitation is set ex-works to the rated current of the device (I_{dN}). This value may be reduced (see also 2.3). Settings can be made separately for the two directions of current-flow. When the current as set on the current limitation potentiometers is reached, the LED "I_{dN}" lights up.

Setting on the potentiometer "+I_{dN}" : current torque anti-clockwise driving or clockwise braking
 "-I_{dN}" : current torque clockwise driving or anti-clockwise braking.

5.5.1 Internal current limitation

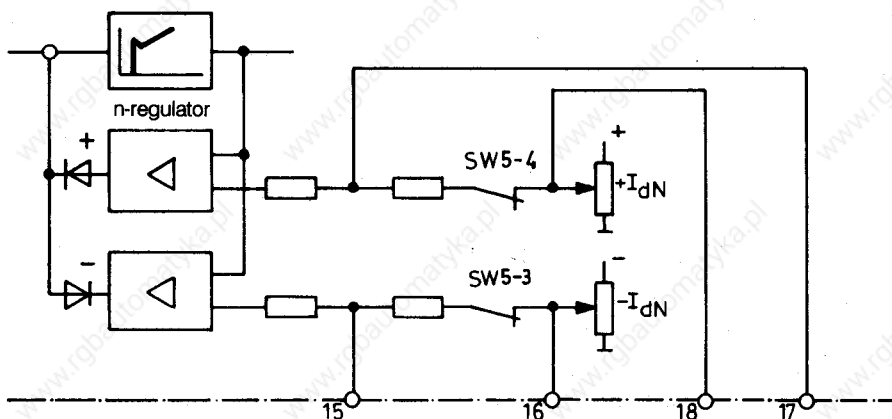

Fig. 5.5.1.1

- SW5-3 and SW5-4 ON = standard
- Current limitation is set with the potentiometers "+I_{dN}" and "-I_{dN}" on card Ry34 (see 6.3.1).

Modification:

1. PI-characteristic = Standard version
 - SW4-1 OFF, SW4-2 OFF
 - CV3 = bridge
 - Calibration of P amplification with potentiometer "p_n" on card Ry34
 - Calibration of I amplification with potentiometer "i_n" on card Ry34.
2. PID-characteristic
 - As under 1, but SW4-2 ON
 - Calibration of the D-component with potentiometer "d_n" on card Ry34

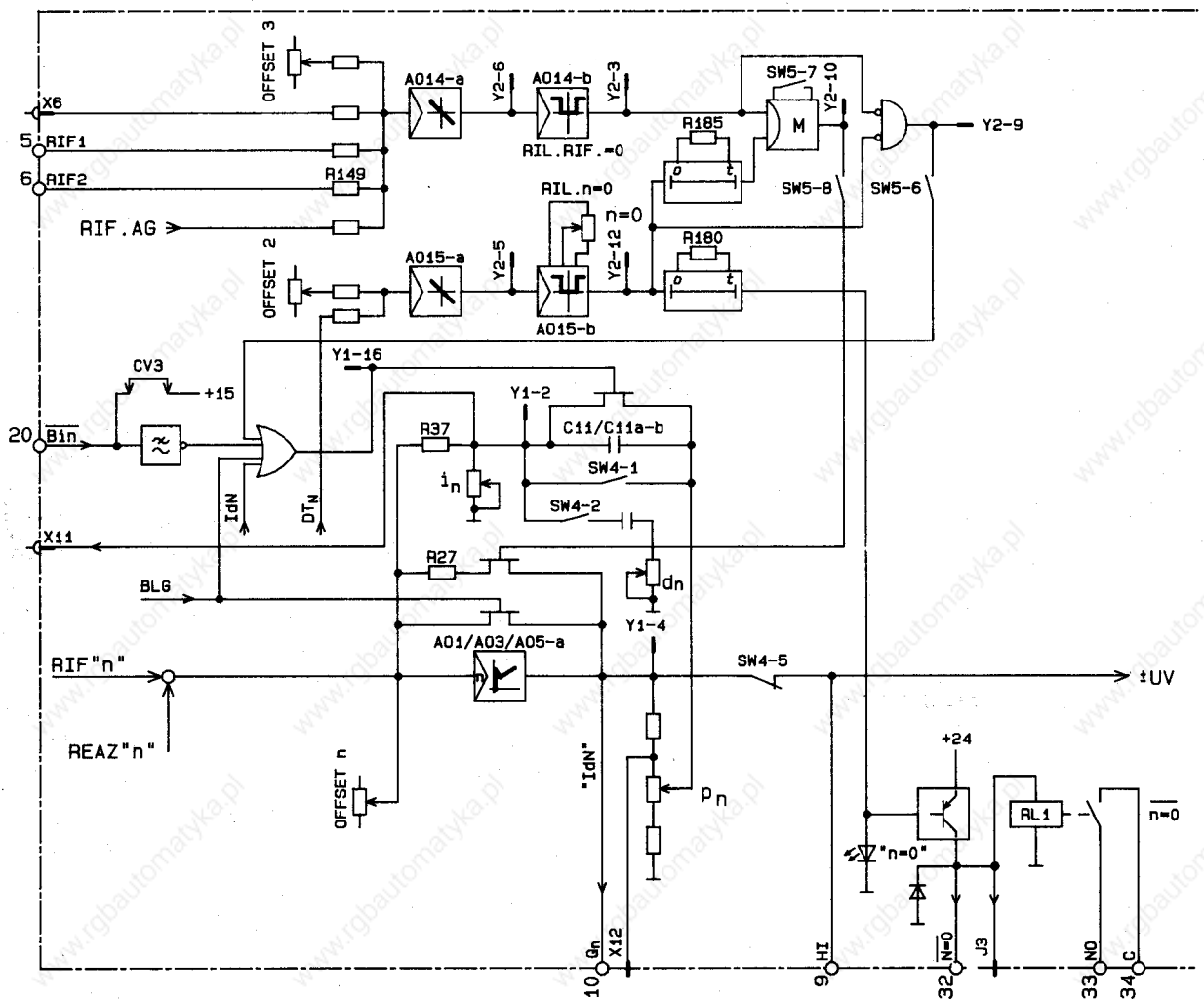

Fig. 5.6.1

3. P-characteristic
 - SW4-1 ON, SW4-2 OFF
 - Potentiometer "i_n" on card Ry34 fully clockwise
 - Calibration of the amplifier with potentiometer "p_n" on card Ry34
4. PI and P-Characteristic
 - SW4-1 OFF, SW4-2 OFF
 - Remove CV3
 - No voltage at terminal 20 → P-characteristic
 - +15...+24 V at terminal 20 → PI-characteristic

Please note: If the current as set on the current flows, the I component of the speed regulator is by-passe

P-, I- and D-components can be calibrated separately.

P-component : The minimum amplification K_{pmin} is 1.4 as standard, and is determined by R37. K_p can be set between 1 and 9.3 K_{pmin} via the potentiometer "p_n". If required, R37 can be exchanged.

$$K_{pmin} = \frac{R37}{50 \text{ k}\Omega}$$

Standard: R37 = 120 k Ω

I-component : The minimum time constant T_{min} is 10 ms and is determined by C11. T_I can be set between 1...50 T_{Imin} with the potentiometer "i_n". The supplementary capacitors C11a and C11b can be fitted in order to increase T_I .

D-component : The minimum time constant T_{dmin} is 8 ms. T_D can be set between 8 and 13 ms via the potentiometer "d_n".

Note: The output signal of the speed regulator is available on terminal 10. It should not be transmitted beyond short distances within the control panel. Wiring should be screened. If lengthy connections are unavoidable, we recommend the use of an Ay-type P-amplifier for decoupling in order to avoid external influences on the reference current value.

Speed regulator matching is provided as standard, but as supplied, is switched off. The following speed regulator behaviour is achieved by switching in the individual matching components.

SW5-8 ON → R27 is switched in parallel to the speed regulator feedback when $n_{ref} = 0$ and $n_{actual} = 0$. The parallel switching of the resistor is time-delayed (under the influence of R180 and R185), switching off is undelayed. This reduces the amplification factor of the n-regulator, and helps protect it from excessive voltages arising at its output, should a high P component in the feedback circuit result in an offset drift occurring when the n-regulator is enabled. (Parallel switching when SW5-8 ON and 0 V at Y2-10).

SW5-7 OFF → The parallel switching of R27 is cancelled, if the speed reference value and/or actual value $\neq 0$.

SW5-7 ON → The parallel switching of R27 is cancelled only if the speed reference value $\neq 0$.

SW5-6 ON → I-component of the speed regulator feedback is blocked when $n_{ref} = 0$ and $n_{actual} = 0$. In this case the capacitors of the n-regulator feedback are shorted out.

This prevents

- The motor accelerating briefly in the reverse direction when it is stopped.
- The offset drift of the n-regulator leading to restarting of the motor from stand-still if the regulator is enabled.

(Blocking of the I-component when SW5-6 ON and 0 V at Y2-9).

Note: The response threshold for the $n_{actual} = 0$ -recognition is dependent on the setting of the potentiometer "n = 0" (see 5.3.3).

When using terminal 6 as input for the preset value or correction value the resistor R149 has to be appropriately rated.

Terminal 6 preset value input

$$R149 = \frac{U_6}{0,5 \text{ mA}} - 22 \text{ k}\Omega$$

Terminal 6 correction input

$$R149 = \frac{U_6 \cdot 100\%}{0,5 \text{ mA} \cdot \dots\%} - 22 \text{ k}\Omega$$

Please note: If the motor to be regulated has to produce a torque when it is at a standstill, SW5-6 and SW5-7 are to be switched to the OFF position. Where very wide speed regulation ranges are involved, we recommend the use of a supplementary card (APSy), through which the speed regulator amplification is related to the speed.

Standard: R27 = Bridge
R149 = Bridge

5.7 Current regulator

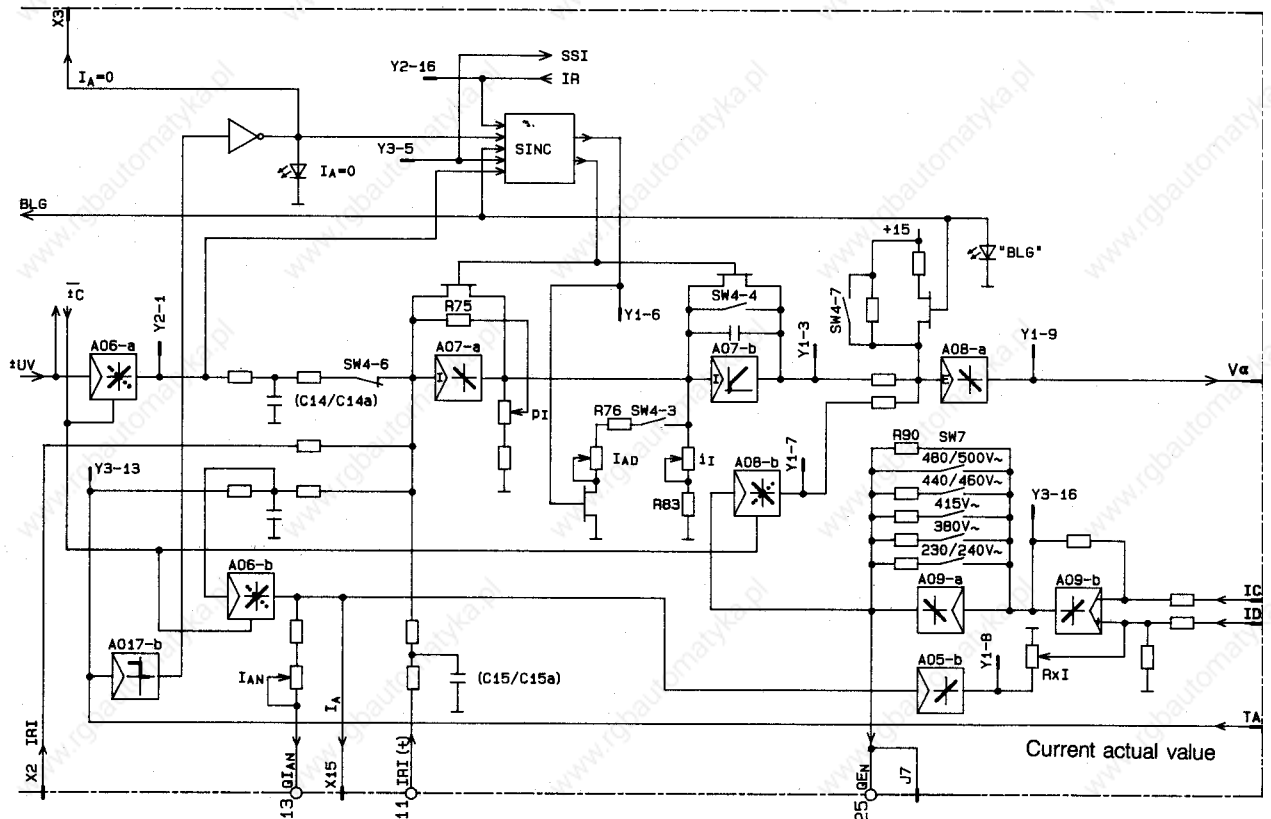

Fig. 5.7.1 Current regulator

The current regulator is a PI regulator with power-dip matching. P- and I-components can be calibrated separately.

P-component : The minimum amplification K_{pmin} is 0.1 as standard and is determined by R75. K_p can be set between 1 and 11. K_{pmin} with the potentiometer "p1". If required, R75 can be exchanged.

$$K_{pmin} = \frac{R75}{112 \text{ k}\Omega}$$

Standard: R75 = 12 kΩ

I-component : SW4-4 ON = I-component switched off
 SW4-4 OFF = I-component activated = standard
 The minimum time constant T_{Imin} is determined by R83. Potentiometer "ij" provides infinite adjustment of T_I .
 The following applies:

Rating	$T_{Imin} = 0,47 \cdot R83$	T [ms]
	$T_{Imax} = 0,47 \cdot (R83 + 50 \text{ k}\Omega)$	$R83$ [k Ω]

Standard: $R83 = 10 \text{ k}\Omega$ Pot. "ij" = $50 \text{ k}\Omega \rightarrow T_I = 4,7...28 \text{ ms}$

If required, the value of R83 can be changed.

Power-dip matching: SW4-3 ON = power-dip matching activated = standard
 SW4-3 OFF = power-dip matching switched off
 The effect of +15...+24 V at terminal 21 enables the regulator. When the regulator is blocked the LED "BLG" lights up. In the majority of cases the reference current value from the output of the speed regulator comes via an absolute value stage. Allocation to the required bridge is via the internal logic. See 5.8 for all other reference values.

5.8 Current regulation

Positive current (torque) direction \rightarrow LED "MP" lights up
 Negative current (torque) direction. \rightarrow LED "MN" lights up

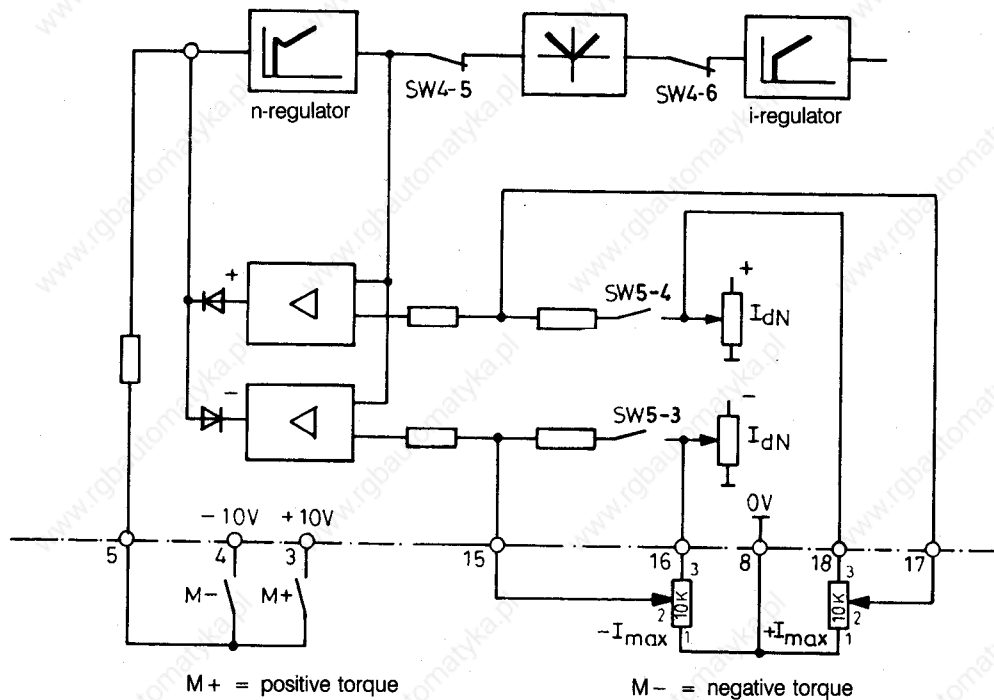

Fig. 5.8.1

Connect circuit as in fig. 5.8.1 SW5-3 and SW5-4 are to be switched to OFF. The LED "IdN" lights up in this mode of operation.

Positive torque direction (current direction) : + 10 V on terminal 5. The current reference value can be set on potentiometer " -I_{max}". The maximum value is determined by the maximum setting of the internal potentiometer " -I_{dN}".

The LED "MP" lights up

Negative torque direction (current direction) : - 10 V on terminal 5. The current reference value can be set on potentiometer " +I_{max}". The maximum value is determined by the setting of the internal potentiometer " +I_{dN}".

The LED "MN" lights up

Other current regulation facilities:

Please note: The internal current limitation is ineffective in this case. The rated current I_{dN} of the unit must not be exceeded.

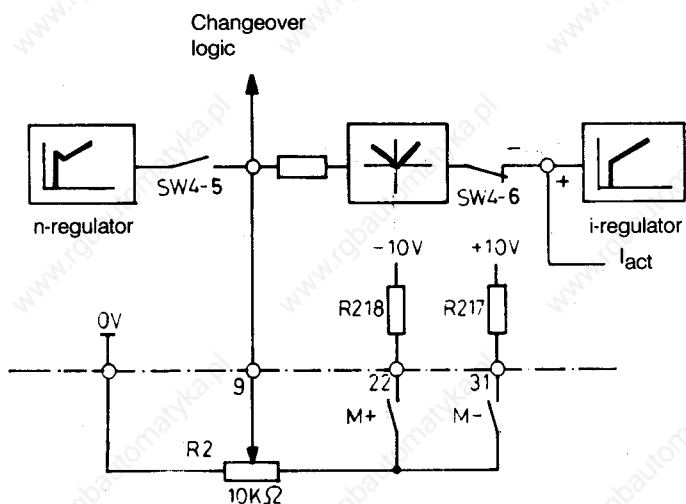

Fig. 5.82

Current reference value inserted via terminal 9 with ± 10 V maximum, 0.2 mA maximum. In this case SW4-5 is to be switched to the OFF position.

Positive current (torque) direction : Contact "M +" closed R218 determines the current when R₂ is turned fully clockwise.

Negative current (torque) direction : Contact "M -" closed R217 determines the current when R₂ is turned fully clockwise.

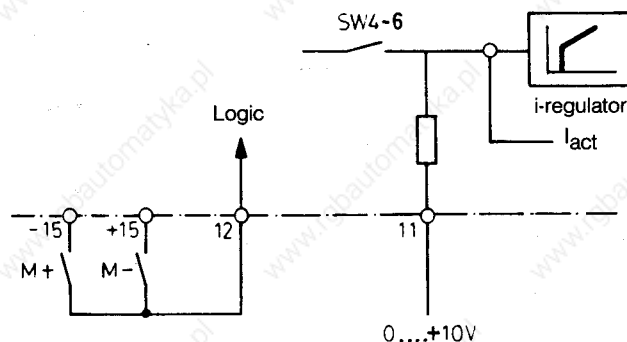

Fig. 5.83

Setting of the current reference value inserted via terminal 11, with 0... + 10 v. SW4-6 to be switched to the OFF position. The current (torque) direction is determined by the voltage at terminal 12.

- 15 V → positive direction (LED "MP" lights up)

+ 15 V → negative direction (LED "MN" lights up)

5.9 Changeover logic

See fig. 5.9.1 for mode of operation.

The purpose of the changeover logic is to allocate the appropriate bridge in accordance with the required direction of torque, to which end the polarity of the speed regulator output signal has to be evaluated. Upon recognition of a change in the direction of rotation at the time t_1 , the second ignition pulses are suppressed at t_2 , and the current regulator is blocked. The current decays and at t_3 , equals 0 (Recognition by means of voltage measurement via the thyristors). Subsequently: ignition pulses are blocked (LED "SI" lights up) and the previously active bridge is switched off. When the torque-free time of approximately 0.5 ms has elapsed, the other bridge is switched in, and the pulse enabled.

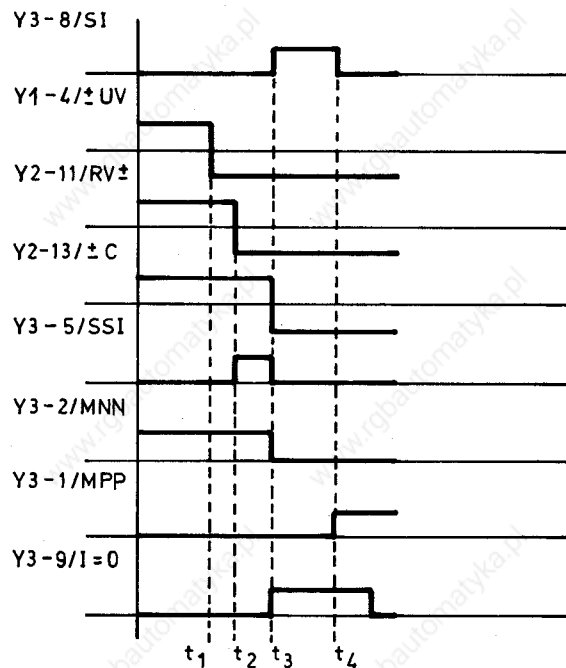

Fig. 5.9.1

Measuring points of the changeover logic

- | | |
|-------|---|
| Y2-11 | Recognition of the direction of torque required |
| +15 V | Negative direction of torque = bridge "MN" |
| -15 V | Positive direction of torque = bridge "MP" |
| Y2-13 | +15 V Bridge for negative direction of torque is actuated |
| | -15 V Bridge for positive direction of torque is actuated |
| | This signal corresponds to that on Y2-11, but is not accepted during changeover until $I = 0$. |
| Y3-1 | +15 V Bridge for positive direction of torque is enabled |
| | LED "MP" lights up |
| | 0 V Bridge MP is blocked |
| Y3-2 | +15 V Bridge for negative direction of torque is enabled |
| | LED "MP" lights up |
| | 0 V Bridge MP is blocked |
| Y1-4 | Output signal of the speed regulator |
| | Positive : negative torque required (MN) |
| | Negative : positive torque required (MP) |
| Y3-5 | +15 V The second pulses are suppressed |
| | 0 V The second pulses are not suppressed |

Y3-8 Pulse limitation
 +15 V Pulse limitation
 0 V No pulse limitation

Y3-9 I = 0 recognition
 +15 V I_A = 0
 0 V I_A ≠ 0

5.10 Control section

The control section is on the card My34, on the back of the hinged regulator card Ry34. My34 controls the sinusoidal firing angle of the thyristor, and produces a d.c. voltage which is, proportional to the mean value of the armature voltage. Mains voltage fluctuations are automatically compensated. The ignition angle limitation is works calibrated.

Matching to the mains frequency is via SW6.

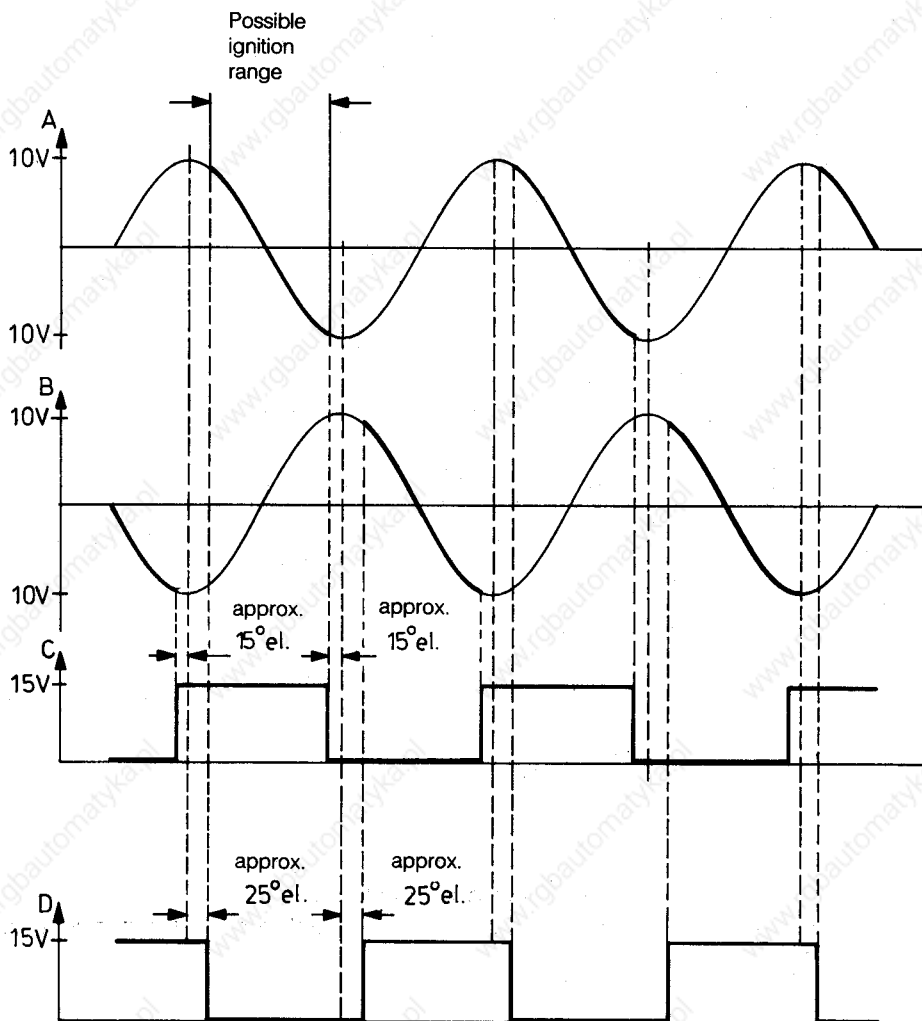

Fig. 5.10.1 Ignition angle limitation

- Signal A Synchronization of positive half-wave
- Signal B Synchronization of negative half-wave
- Signal C Limitation of maximum ignition angle
- Signal D Limitation of minimum ignition angle

Phase	Measuring points for			
	A	B	C	D
U	Y4-6	Y4-4	Y4-7	Y4-14
V	Y2-2	Y4-1	Y4-9	Y4-13
W	Y4-16	Y4-20	Y4-12	Y4-15

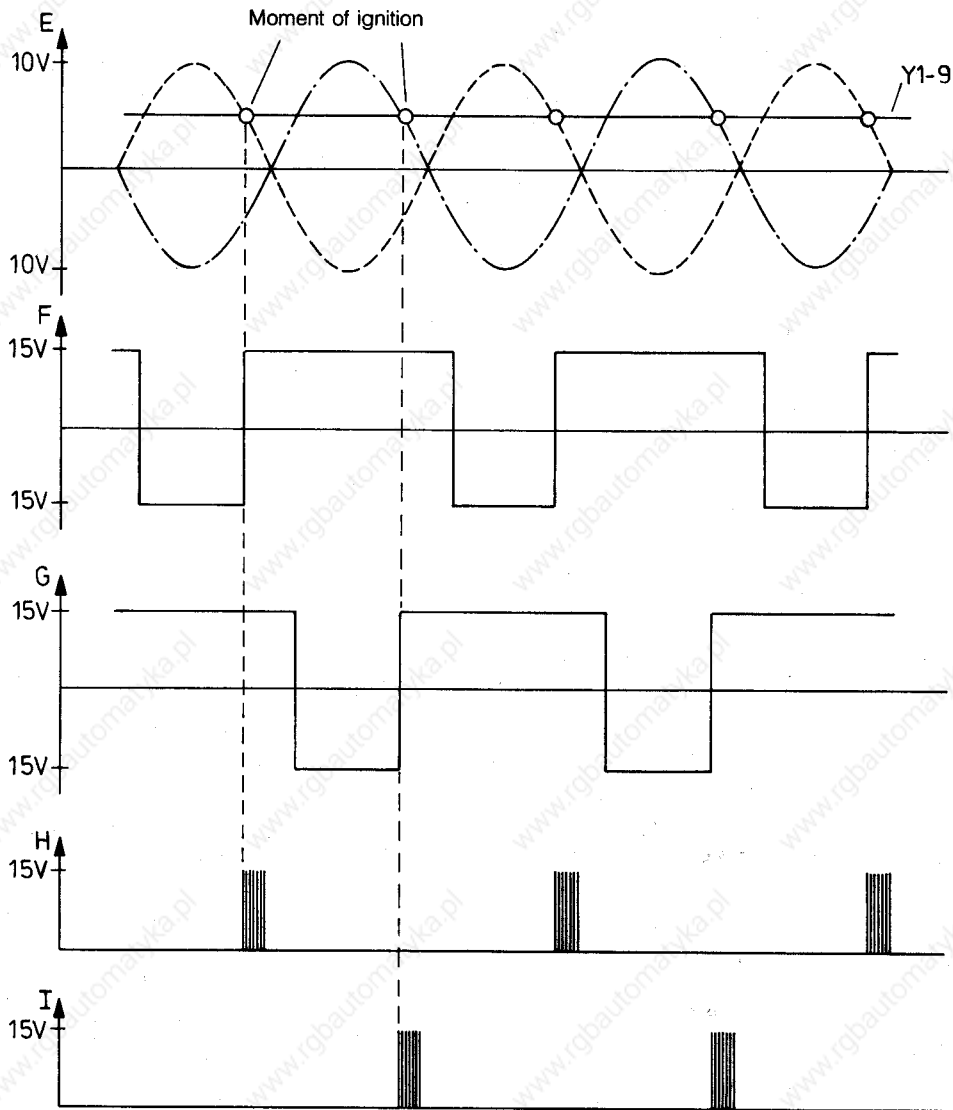

Fig. 5.10.2 Pulse generation

- Signal E Synchronization voltage
- Signal F Preset value ignition position halfwave
- Signal G Preset value ignition negative halfwave
- Signal H Pulse chain position halfwave
- Signal I Pulse chain negative halfwave

Phase	Measuring points for				
	E	F	G	H	I
U	Y4-6/Y4-4	Y4-5	Y4-17	Y5-6	Y5-12
V	Y4-2/Y4-1	Y4-10	Y4-3	Y5-13	Y5-3
W	Y4-16/Y4-20	Y4-19	Y4-18	Y5-14	Y5-2

5.11 Control circuits

There are three control circuits within the TPy3...4B converters:

- AF LED "AF" lights up to indicate a blown fuse or fuses, on the a.c. side of the power section and in the protective circuit. The function of AF is switched off when SW5-5 is ON.
- RSH LED "RSH" indicates the short-circuit of the preset values or overload.
- AR LED "AR" lights up to indicate:
 - Blown fuse in the regulator supply (on the a.c. and d.c. side)
 - Mains undervoltage
 - Overload on the supply voltages

Converters OK*:

- Contact between the terminals 35 and 36 (250 V a.c., 3 A, AC-11) closed
- Static signal on terminal 37 = +24 V (load capacity: 10 mA)
- LED "AL" does not light up
(* supply voltage present on terminals 1U, 1V, 1W).

If one or more of the above mentioned faults should occur:

- Contact between terminals 35 and 36 opens
- The static signal on terminal 37 = 0
- The LED "AL" lights up
- Regulators are blocked and ignition pulses are suppressed.

This status is stored. To reset: switch off the regulator supply at 1U, 1V, 1W and switch on again.

The converters TPy3- ... / ... -800L ... 2000L-4B have internal fuses in the mains circuit and are self-monitoring. If all the fuses are in order the contact between terminal 83 and 84 (250 V a.c., 2 A) is closed. If one or more fuses blows, it opens. The "AF" control circuit monitors the protective circuit. The converters from 110 A rated current upwards have a device to monitor the temperature of the heat sink. If the temperature becomes excessive, the potential-free contact between terminals 61 and 62 opens.

6. Commissioning instructions

The circuit must be connected as shown in fig. 4.2.1. and 4.2.2. The bridge from terminal 33 to 34 of the K1 contactor is not inserted unless electrical "emergency stop" braking is required, and then only after commissioning has been completed.

6.1 Assembly test

Before switching on the following are to be checked:

- Correct connection of all wiring
- It power and regulator sections are supplied separately
 - CV-U, CV-V and CV-W should be removed (2.1)
 - Phase position (2.1)
- Fuse type (2.5.3)
- Setting of the overload relay (4.2)
- Mains voltage (2.1.)
- Matching to the mains frequency using SW6-2...4 (2.1)
- Position of the micro switches (13)
- Rating of the n-actual value input (Table under 13.1)
- Matching to the field current for units ≥ 800 A (2.4.)

6.2 Checking the auxiliary voltage

- Regulator blocked (disconnect connection on terminal 21)
- Switch on system
- Check the voltages supplied by the converter, in accordance with table under 5.1
- Potentiometer "n_{min}" on card Ry34 fully anti-clockwise
- 0-voltage must be present on terminal 1 of the preset value potentiometer
- If clockwise rotation is selected, +10 V must be present at the terminal of the reference value potentiometer, and if anti-clockwise rotation, this must be -10 V.
- If the preset value potentiometer is turned fully anti-clockwise, 0 V must be present at terminal 5 or 28 of the converter (without or with ramp function generator). If it is turned fully clockwise this voltage must be +10 V or -10 V
- When the motor is at operating temperature, calibrate the field using any available field resistor
- Switch off motor, reconnect wires to terminal 21.

6.3 Commissioning

- Set reference value potentiometer R1 to approximately 20% of the preset value, select direction of rotation as required
- Switch on motor
- If the motor accelerates out of control, switch off main switch and check actual value connection (matching with SW3, Actual value voltage available at terminal 1; the polarity of the actual value terminal must be opposite to that of the reference value terminal).
- Switch off motor.

6.3.1 Current limitation, EMF anticipatory control, Rxl compensation, current indication

During this setting the current is measured via an ammeter in the armature circuit (possibly with shunt), since the output for current indication (terminal 13) is not calibrated until the commissioning stage. The converter rated current I_{dN} is set ex-works. Under no circumstances must the set figure be exceeded. If a reduction or resetting should be necessary, proceed as follows:

- Switch off motor
- Turn potentiometers "+ I_{dN} " and "- I_{dN} " fully anti-clockwise
- If current is externally limited, turn external potentiometer fully anti-clockwise
- Disconnect motor field. Motor must not rotate during this setting, block if necessary
- Bridge out control terminals S3 and S4 of the field current relay
- Turn n-preset value potentiometer fully clockwise
- Select clockwise rotation (preset value +)
- Switch on motor
- Set the required current on the potentiometer "- I_{dN} " on card Ry34
- Connect voltmeter between terminal 25 and 0 V
- Set SW7 in accordance with table under 13.1
- Set the voltage at terminal 25 to 0 V, using potentiometer "Rxl" = calibration of anticipatory control and Rxl compensation
- Disconnect voltmeter
- An ammeter connected to terminal 13 is now calibrated, using potentiometer " I_{AN} " (see 5.5.3)
- Select anti-clockwise rotation (reference value -)
- Set desired current using potentiometer "+ I_{dN} " on card Ry34
- Switch off motor
- Remove bridge between terminals S3 and S4 of the converter
- Connect field

6.3.2 Rated motor speed, speed indication

See also 5.3.

- Check position of switch SW3... in accordance with table under 1.1
- Turn potentiometer " n_{max} " on card Ry34 fully anti-clockwise
- Switch on motor
- Slowly turn preset value potentiometer to the right-hand stop
- Set the required speed by turning the trimmer " n_{max} " clockwise
- A speed indicator connected to terminal 14 is now calibrated using potentiometer "DTN" (see also 5.4.3).

6.3.3 Minimum speed

- Turn preset value potentiometer R1 fully anti-clockwise
- Switch on motor
- If circuit is connected as in fig. 5.4.3.1 the minimum speed can be set using the potentiometer " n_{min} " on card Ry34.

6.3.4 Ramp function generator

The run-up and run-down times are determined by means of resistors R141A, B, C and R142A, B, C (see 5.4.1). Timers can be set in the ratio 1:12, using potentiometer "+a" and "-a".

6.3.5 Offset adjustment n-regulator

If the motor rotates while the preset value potentiometer is turned fully anti-clockwise and n_{min} function is not in use, this is because speed n-regulator is offset. Adjust as follows:

- Disconnect all preset and correction value wires
- Connect reference value input (terminals 5 or 28) with 0 V
- SW4-1 ON, SW4-2 OFF
- Connect voltmeter between terminal 10 (output speed-regulator) and 0 V
- Switch on converter
- Set 0 V on card Ry34 using trimmer "OFFSET"
- Switch off converter
- SW4-1 OFF, SW-2 in position required
- Remove 0 V bridge
- Reconnect reference and correction value cables.

If the motor should still rotate although the reference value potentiometer is fully anticlockwise, this is because of the residual resistance of the wiring between terminal 1 of the reference value potentiometer and 0 V. In this case R27 on card Ry34 must be bridged and SW5-8 must be switched to ON. In this case, the motor cannot generate any torque if $n_{ref} = 0$ and $n_{act} = 0$ (see 5.6).

6.3.6 Recognition of offset adjustment $n_{act} = 0$

The adjustment is made ex-works. If a subsequent adjustment should become necessary, proceed as follows

- Connect voltmeter between measuring point Y2-5 and 0 V
- With regulator energized and motor stationary, set 0 V on Y2-5 using trimmer "OFFSET 2".

6.3.7 Recognition of offset adjustment $n_{ref} = 0$

The adjustment is made ex-works. If a subsequent adjustment should become necessary, proceed as follows:

- Disconnect all preset and correction value cables
- Connect preset value input (terminal 5 or 28) to 0 V
- Connect voltmeter between metering point Y2-6 and 0 V
- Set 0 V on Y2-6 using trimmer "OFFSET 3"
- Set 0 V on Y2-6 using trimmer "OFFSET 3"
- Switch off motor
- Remove 0 V bridge
- Reconnect preset and correction value wires.

6.3.8 Stabilization of n-regulator

If the speed should oscillate, this can be eliminated in most cases by adjusting the potentiometers " p_n ", " i_n " and " d_n " on card Ry34, in which case, the relevant component will increase. If this is not enough, the converter must be tuned (see 6.4).

6.4 Tuning

In tuning the converter, the time constant of the regulators is matched to the motor parameters.

The regulators should react as quickly as possible to a change in the regulator circuit (reference value change or interference) without overshooting. The regulator amplification can be regulated via the potentiometers " p_n ", " i_n ", " d_n ", " p_l " and " i_l ". Tuning starts with the current regulator.

6.4.1 Current regulator

- Disconnect motor field, motor must not rotate, block if necessary
- Bridge control terminals 53 and 54 of the converter (field current relay)
- SW4-1 ON = I-amplification of speed-regulator switched off
- SW4-2 OFF = D-amplification of speed-regulator switched off
- Potentiometer " i_n " turned fully clockwise
- Potentiometer " p_n " turned fully clockwise
- Potentiometer " p_l " turned fully anti-clockwise
- Potentiometer " i_l " turned fully clockwise
- Potentiometer " I_{AD} " turned fully anti-clockwise
- SW4-3 ON = matching switched in
- The ramp function generator is to be blocked and the slide of the preset value potentiometer is to be connected to terminal 5
- Disconnect other reference or correction value terminals
- Store oscilloscope or chart recorder to be connected at metering point Y3-13
- External switches S1 and S2 are to be connected as in Fig. 6.4.1.1.

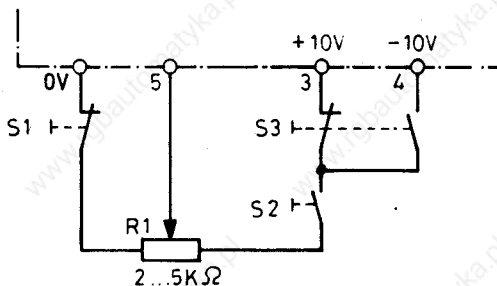

Fig. 6.4.1.1

6.4.1.1 Calibration with continuous current

- Turn external potentiometer R1 fully anti-clockwise
- Switches S1 and S2 closed, S3 optional
- Switches on motor
- Set current dip limit via R1 (setting is maintained during tuning)
- Actuate S1 and record actual current value
- Check whether the current gain is as fast as possible, but without overshoot (Fig. 6.4.1.1.1)
- If current gain is too slow (Fig. 6.4.1.1.2) turn potentiometer "p1" anti-clockwise and check **new setting**
- If overshoot occurs (Fig. 6.4.1.1.3) turn potentiometer "p1" anti-clockwise and check **new setting**
- If the setting of the potentiometer "p1" does not lead to an optimum result, the setting range can be **modified** by changing the value of R75. In this case the regulator gradient increases as the R75 values **increase**, and vice versa.
- Follow this by turning potentiometer "ij" slowly anti-clockwise until current fluctuations occur, **then turn back slightly**
- If the setting of the potentiometer "ij" does not lead to an optimum result, the setting range can be **modified** by changing the value of R75. In this case the regulator gradient increase as the R83 values increase, **and vice versa**
- Check setting at differing preset value polarities
- Switch off motor.

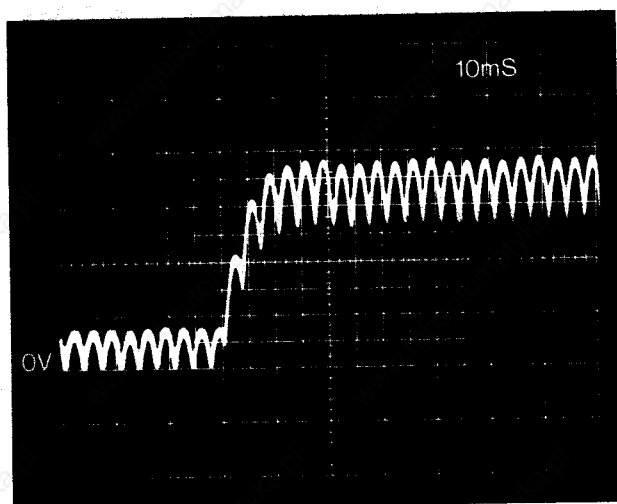

Fig. 6.4.1.1.1

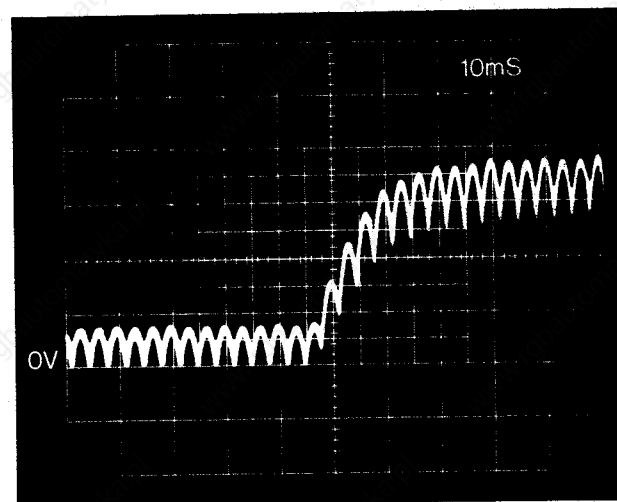

Fig. 6.4.1.1.2

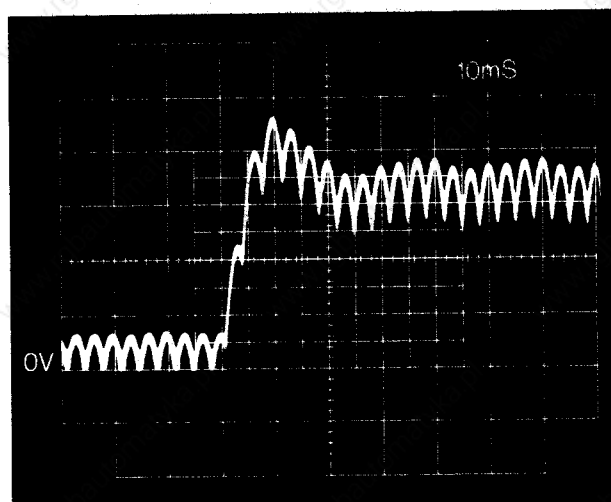

Fig. 6.4.1.1.3

6.4.1.2 Calibration with discontinuous current

- Turn potentiometer "I_{AD}" fully anti-clockwise
- External switch S1 closed, S2 not actuated
- R1 same setting as before (gap limit)
- Switch on motor
- Using switch S2, switch reference voltage on and off, and record actual current value
- Check whether the current gain is as fast as possible, but without overshoot (Fig. 6.4.1.2.1)
- When the gain is too slow (Fig. 6.4.1.2.2) turn potentiometer "I_{AD}" anti-clockwise and check new setting
- If overshoot occurs (Fig. 6.4.1.2.3), turn potentiometer "I_{AD}" anti-clockwise and check new setting
- If adjustment of the potentiometer "I_{AD}" does not lead to an optimum result, the setting range can be modified by changing the value of R76. The rate of gain increases as the value of R76 is reduced
- Check setting at differing preset value polarities
- Switch off motor.

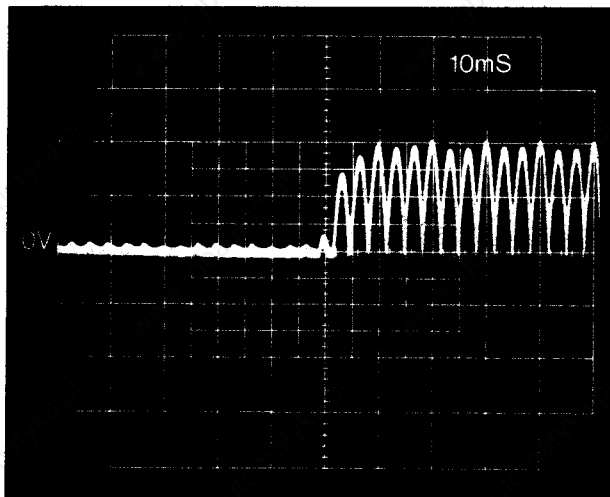

Fig. 6.4.1.2.1

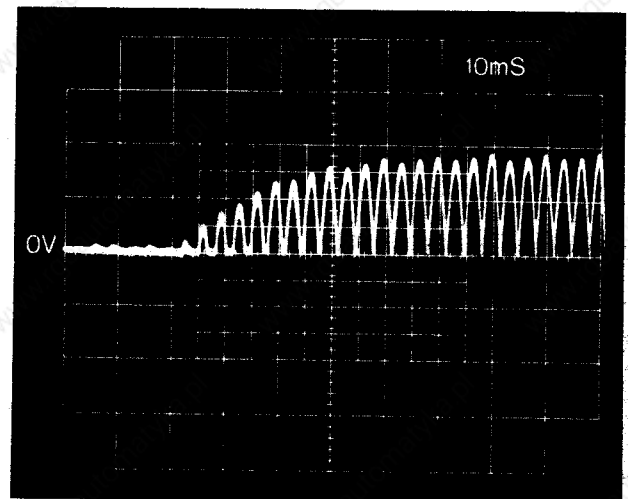

Fig. 6.4.1.2.2

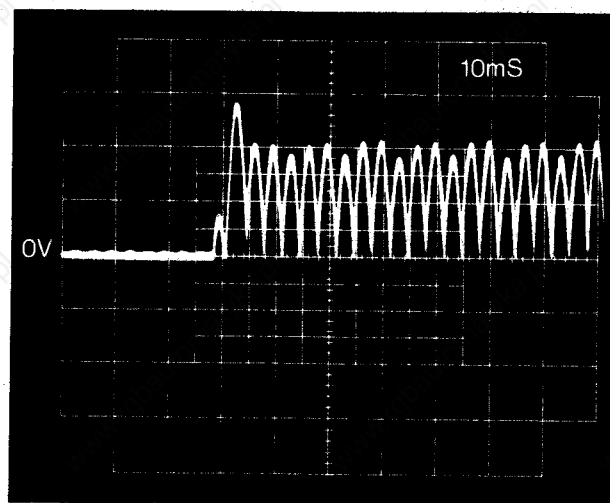

Fig. 6.4.1.2.3

6.4.1.3 Checking the overall setting

- S1 open
- Switch on motor
- Using switch S2, switch reference voltage on and off, and record actual current value
- No overshooting must occur (see Fig. 6.4.1.3.1)
- ~~If overshooting should nevertheless occur, turn potentiometer "I_D" anti-clockwise~~
- Check setting at differing preset value polarities
- Switch off motor
- Disconnect oscilloscope or chart recorder
- Remove bridge between control terminals 53 and 54
- Connect motor field

(The following is omitted if speed regulator is to be calibrated)

- SW4-1 OFF
- Disconnect external switches
- When using the ramp function generator: connect reference value and generator enable
- Connect other preset or correction values

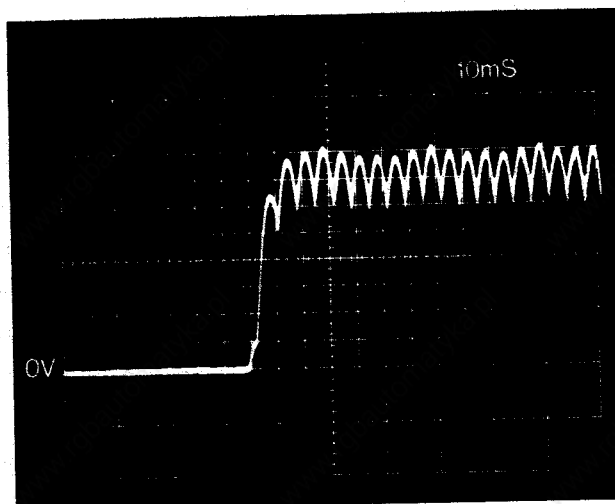

Fig. 6.4.1.3.1

6.4.2 Speed regulator

- SW4-1 ON = I-component switched off
- SW4-2 OFF = D-component switched off
- Block ramp function generator if fitted, connect slide of reference value potentiometer to terminal 5
- Disconnect all other reference or correction values
- Potentiometer "p_n" turned fully anti-clockwise
- Potentiometer "i_n" turned fully clockwise
- Potentiometer "d_n" turned fully anti-clockwise
- Connect reference value potentiometer as shown in Fig. 6.4.1.1
- S1 closed
- S2 open
- S3 as required
- Turn external potentiometer R1 fully clockwise
- Oscilloscope or chart recorder: Channel 1 at measuring point Y1-15 (n-actual value)
Channel 2 at measuring point Y1-4 (output n-regulator)
Reference point: 0 V
- Switch on motor
- Close S2, taking note of signals
- Using potentiometer "p_n" set the amplification so that the speed (Y1-15) does not overshoot and the s to Y1-4 does not undershoot
- Check calibration for differing preset value polarity

- If the adjustment of the potentiometer " p_n " does not lead to an optimum result, the setting range can be modified by changing the value of R37. The rate of regulator gain will increase as the value of R37 increase, and vice versa
- SW4-2 ON = D-component switched on
- The rate of acceleration will not be as rapid as before
- Set potentiometer " d_n " so that the fastest possible acceleration is achieved
- If rapid changes (oscillation) occur at a stationary reference value (Fig. 6.4.2.3), the motor is not suitable for a D-component and SW4-2 has to be switched to the OFF position. In this case, potentiometer " d_n " should be turned fully anti-clockwise
- If the D-component is maintained, the P-component, as described above, should be re-calibrated by turning the potentiometer " p_n " clockwise
- Switch off motor
- SW4-1 OFF
- Switch on motor
- Turn potentiometer " i_n " slowly anti-clockwise until motor starts to oscillate, then ease back slightly
- The two capacitors C11a and C11b can be fitted to increase the I-component. In this case, both spaces have to be occupied
- Switch off motor
- Disconnect oscilloscope or chart recorder and external switches
- Connect reference and correction values and ramp function generator enable wires to their original terminals.

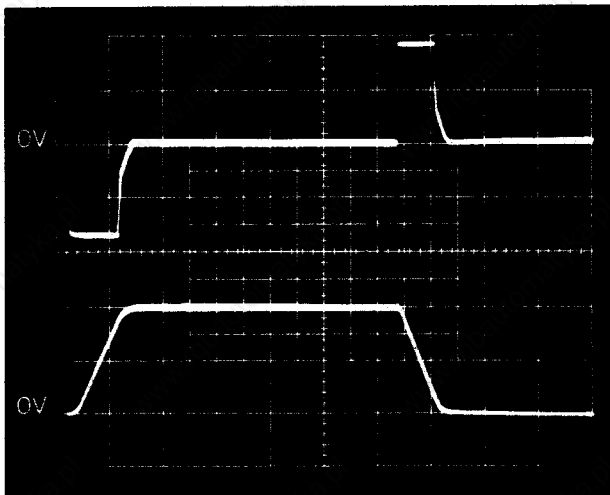

Fig. 6.4.2.1 Ideal

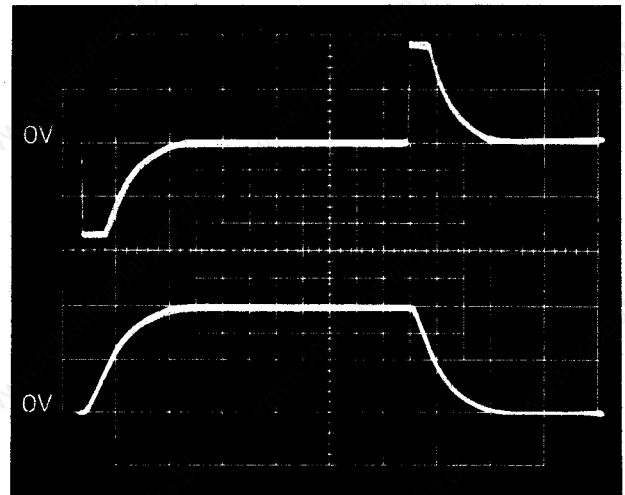

Fig. 6.4.2.2 Only P P too small

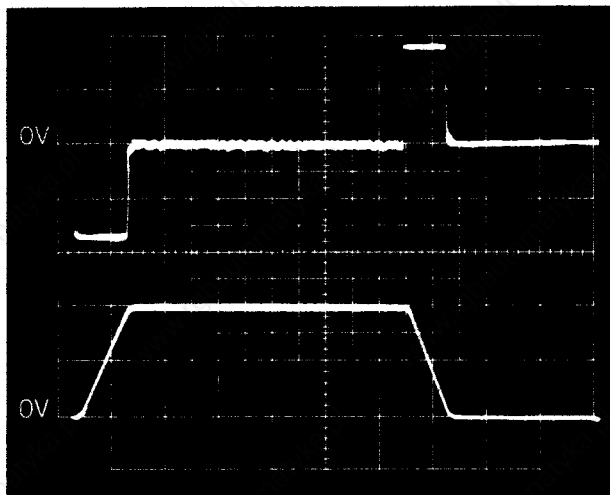

Fig. 6.4.2.3 PD D too large

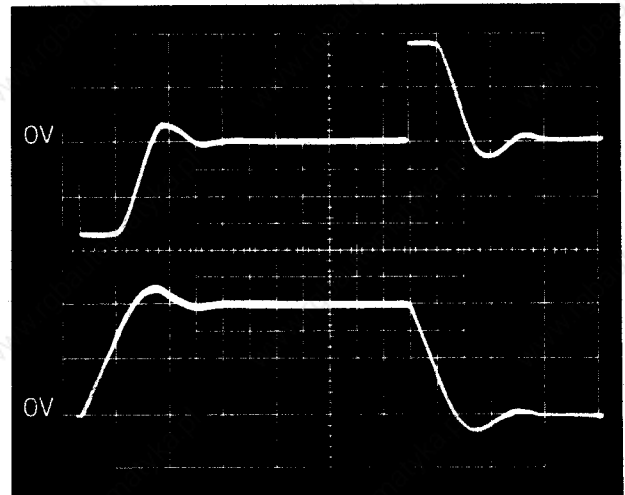

Fig. 6.4.2.4 PI I too large

Note: above Y1-4 = n-regulator output
 below Y1-15 = n-actual value

7. Fault tracing

The following list shows a number of possible faults. These can be attributed in part to user errors, **which can** be eliminated with the aid of the measures described in the foregoing.

a) Motor does not rotate

a1) External fuse on the a.c. side has blown (LED "AF" lights up)

- Current regulator gain too steep → turn potentiometer "p₁" anti-clockwise
- Thyristor faulty. There must be a resistance of several MΩ between the anode and the cathode. To check, switch off system and disconnect motor or remove d.c. fuses
- Earth fault in the armature circuit
- When power and regulator sections are fed separately, regulator was enabled before voltage was applied to U, V and W
- Check visually whether the LED "MP" lights up with positive reference value and the LED "MN" with negative reference value. When switching over the reference value, the LED's "MP" and "MN" have to be extinguished briefly, while the LED "S1" lights up

a2) External fuse on the d.c. side has blown

- Main contactor K1M or main switch has been opened during braking mode
- Earth fault in the armature circuit
- Current regulator gain too steep → Turn potentiometer "p₁" anti-clockwise

a3) Main contactor open

- Check energization criteria (motor protection, control circuits, etc.)

a4) Main contactor closed, external fuses o.k.

- Is motor connected properly?
- LED "± 15V" does not light up → no supply voltage, regulator fuse blown
- LED "I_{dN}" lights up → interruption in the armature circuit, no field, motor mechanically braked, current limitation too low
- Is regulator enabled? LED "BLG" must not light up
- Are SW4-5 and SW4-6 ON?
- During operation without ramp function generator: is reference value present at terminal 5?
- During operation with ramp function generator: is reference value present at the generator inp (terminal 28) and is SW5-2 ON?
Are ramp function generator and reference value enabled, and input voltage present?

b) Motor does not reach rated speed

- Potentiometer "n_{max}" is set incorrectly and/or SW3-... is coded incorrectly
- LED "I_{dN}" lights up → Motor drawing maximum current, relieve load on motor or increase current limitation (max. I_{dN}) check field current
- Are all six thyristors of a bridge actuated? Six pulses must occur per mains cycle (20 ms at 50 Hz, 16,7 ms at 60 Hz)

c) Motor runs up too slowly

- LED "I_{dN}" lights during acceleration → Motor draws maximum current while accelerating. Relieve load on motor or increase current limitation (maximum I_{dN}), check field current
- LED "I_{dN}" does not light up → ramping time too long. Try using the direct input of the speed-regulator (terminal 5) for the preset value

d) Motor can be regulated only in the upper speed range

- No 0 V connection to the preset value potentiometer

- e) Motor runs in the right direction, but cannot be regulated
 - Actual value wiring either missing or of incorrect polarity (terminal 1)
 - Phase position between power and regulator sections incorrect (see 2.1)
 - No 0 V connection to the reference value potentiometer
- f) Motor rotates in the wrong direction, but can be regulated
 - Check reference value polarity, otherwise:
 - Reverse polarity of field and tachometer connections
- g) Motor rotates in the wrong direction, and cannot be regulated
 - Reverse polarity of motor field.

8. Bus connection X for the connection of optional equipment

When supplementary internal cards are fitted, the signal exchange between card and converter and the supply is via bus X (connection via 16-pole ribbon-type cable).

I = Input Q = Output

Designation	I/Q	Function	ESE 1590		ESE 1593	
			sheet	pos.	sheet	pos.
X 1	Q	+24V Voltage supply	5	B9	2	E6
X 2	I	IRI Input current regulator, $\pm 10V$ max Internal current limitation not effective Input resistance 66 k Ω	2	A3	2	E1
X 3	Q	I _A =0 Logic signal, load capacity 3 mA 0V → Armature voltage flowing +15V → No armature voltage	3	A3	2	A1
X 4	Q	I _{dN} Logic signal, load capacity 3mA 0V → Current limitation level reached +15V → Current limitation level not reached	1	B9	1	C1
X 5	Q	DT _N Standardized actual value voltage, 10 V max. 4 mA Negative or positive, as terminal 1	1	A5	1	E5
X 6	I	RIFx Supplementary speed-regulator for reference and actual values, input resistance 47 k Ω	1	A1	1	C1
X 7	—	Not occupied				
X 8, X 10	—	0V Regulator reference point	5	A9	2	E7
X 9	Q	-15V Voltage supply	/	b%	+	e)
X 11, X 12	Q	Points of speed-regulator feedback for switching on the APSy adapter for high regulating ranges	1 1	C9 A4	1 1	C1 E6
X 13	Q	\overline{BL} Logic signal to enable the cards, 3 mA max 0V → Blocking +15V → Enable The signal is coupled with the command at terminal 21 of the converter and the on-delay when the voltage is applied to the regulator section	3	E5	2	A4
X 14	I	\overline{BLA} Input for blocking the regulator with an external signal 0V → Blocking +15V → Enable, 0.3 mA	3	D1	2	A4

Designation	I/Q	Function	ESE 1590		ESE 1593	
			sheet	pos.	sheet	pos.
X 15	Q	I_A Actual current value Load capacity 4 mA max. dependent on connection to terminal 13 Voltage supply	2	E4	2	E2
X 16	Q	+15V Voltage supply	5	A9	2	E6

8.1 J-connector for interconnection with a 2Q-field controller

The connector is on the Ry34 regulation card.

Designation	I/Q	Function	ESE 1590		ESE 1593	
			sheet	pos.	sheet	pos.
J 1	Q	+15V Supply voltage	5	A9	2	E7
J 2	Q	Q_n Speed regulator output $\pm 10V$ max. included term. 10	1	E5	1	E6
J 3	Q	$n=0$ Zero speed output; L=enable 0.../+24V, 10 mA max included term. 32	6	D9	1	E9
J 4, J 5	—	0V Regulator reference point	5	A9	2	E7
J 6	Q	-15V Supply voltage	5	B9	2	E8
J 7	Q	QE_N E - trasducer output normalized approx $\pm 10V$, 3 mA max. included term. 25	2	E9	2	E6
J 8	I	\overline{BLA} Disable command from field controller, 0,3 mA; 0V \rightarrow blocking; +15V \rightarrow enable	3	D1	2	A4
J 9	Q	DT_N Normalized tachometer feedback $\pm 10V$ 4 mA max. included pin X 5	1	A5	1	E5
J 10	Q	+24V Supply voltage	5	B9	2	E6

9 Test points available

9.1 Regulator card Ry34

Designation	Function	ESE 1590		ESE 1593	
		sheet	pos.	sheet	pos.
Y1-1	Output I_{max} -amplifier (+) Motor not in current limitation approx $\rightarrow -15V$ Motor in current limitation $> 0V$	1	D4	1	D6
Y1-2	Internal signal of the D-component of the regulator	1	C7	1	B6
Y1-3	Output I-regulator, approx $-15V$ max.	2	B6	2	C5
Y1-4	Output n-regulator, $\pm 10V$ max	1	B9	1	C6
Y1-5	Not occupied	—	—	—	—
Y1-6	Actuation signal for the dip matching of the current regulator 0V $\rightarrow I_A \neq 0$ +15V $\rightarrow I_A = 0$	2	A4	2	C4
Y1-7	EMF signal for the anticipatory control of the modulator, -8...10V max	2	D3	2	D5
Y1-8	Armature current, smoothed, $\pm 4V$ max	2	D9	2	E6

Designation	Function	ESE 1590		ESE 1593	
		sheet	pos.	sheet	pos.
Y1-9	Pulse - control signal	2	B7	2	C6
Y1-10...13	Not occupied	—		—	
Y1-14	Output I _{max} -amplifier (—) Motor not in current limitation → approx. +15V Motor in current limitation → < 0V	1	D4	1	D5
Y1-15	n-actual value signal, approx. ±2V max.	1	A2	1	D4
Y1-16	Blocking I-component n-regulator 0V → Enable +15V → Blocking	1	B8	1	B5
Y2-1	Reference current value +10V max	2	B2	2	C1
Y2-2	Synchronization for the application of dip matching	5	D4	—	
Y2-3	n _{ref} = 0-recognition of the n-regulator matching +15V → n _{ref} ≠ 0 -15V → n _{ref} = 0	6	B4	1	A6
Y2-4	Fault indication "AR" 0V → Fault +15V → No fault	5	D4	2	B8
Y2-5	Output of the input amplifier of n _{ref} = 0-recognition of the n-regulator matching approx. ±10V max.	6	B3	1	B6
Y2-6	Output summation amplifier n-reference values for n _{ref} = 0-recognition The polarity is opposed to the of the reference value n _{ref} ≠ 0 → approx. ±10V max.	6	B3	1	A6
Y2-7	Synchronising pulse for use of dip matching Pulse strength: approx. +10...12V, frequency: 6 × mains frequency	5	D8	—	
Y2-8	Input amplification for fault indication "AR" ok = approx. -10V at Y2-8	5	D1	—	
Y2-9	Actuation n-regulator matching 0V → n-reference value and n-actual value = 0 With SW5-6 = ON the I-component of the n-regulator is blocked +15V → n-reference value and/or n-actual value ≠ 0	6	B5	1	A8
Y2-10	Actuation n-regulator matching 0V n-reference value and n-actual value = 0 With SW5-8 = ON, R27 is switched in parallel with the n-regulator feedback +15V → n-reference value and/or n-actual value ≠ 0	6	B7	1	A7
Y2-11	Recognition of the torque direction required +15V → Negative torque = bridge MN -15V → Positive torque = bridge MP	3	C3	2	B2
Y2-12	n-actual value = 0-recognition of the n-regulator matching +15V → n-actual value ≠ 0 -15V → n-actual value = 0 Switching threshold can be set between 0.5 and 3.5% n _{max} with potentiometer "n=0"	6	D5	1	B6
Y2-13	Output circuit for torque reversal Y2-13 reverses polarity after recognized torque reversal and I = 0. +15V → Actuation of bridge MN -15V → Actuation of bridge MP	3	C5	2	B2
Y2-14	Output of the first ramp function generator amplifier +15V → Delay clockwise rotation or accelerate anti-clockwise -15V → Delay anti-clockwise rotation or accelerate clockwise	4	B6	1	A2

Designation	Function	ESE 1590		ESE 1591	
		sheet	pos.	sheet	pos.
Y2-15	Not occupied	—	—	—	—
Y2-16	Synchronization pulse dip matching Pulse strength +10...12V, frequency: 6 × mains frequency	5	E9	2	B
Y3-1	Actuation signal for positive torque +15V → Bridge MP actuated (LED "MP" lights up) 0V → Bridge MP not actuated	3	A9	2	B
Y3-2	Actuation signal for negative torque +15V → Bridge MN actuated (LED "MN" lights up) 0V → Bridge MN not actuated	3	C9	2	A
Y3-3.4	Not occupied	—	—	—	—
Y3-5	Logic signal to suppress second pulses +15V → 2. pulses suppressed 0V → 2. pulses not suppressed	3	D6	2	E
Y3-6	Fault indication "RSH" +15V → No fault 0V → Fault	4	D1	1	F
Y3-8	Reset signal for the ignition pulse chain +15V → No reset 0V → Reset	3	D9	2	I
Y3-9	I _A = 0 → Recognition +15V → I _A = 0 0V → I _A ≠ 0	3	A1	2	
Y3-10	Delay pulse-enable +15V → Pulses not enabled 0V → Pulses enabled	3	B5	—	
Y3-11	Fault indication "AF" +15V → Fault 0V → No fault	5	A3	2	
Y3-12	Logic signal of the bridge actuation +15V → Bridge MN 0V → Bridge MP	3	C5	2	
Y3-13	Current actual value, unsmoothed (always negative polarity)	2	D1	2	
Y3-14	General lock +15V → unblocked 0V → blocked	3	D7	2	
Y3-15	Not occupied	—	—	—	—
Y3-16	Output of the decoupling amplifier for the armature voltage Motor rotating anti-clockwise Motor rotating clockwise	2	D7	2	

9.2 Regulator supply Sy3

Designation	Function	ESE 1592	
		pos.	sheet
SIN U	Synchronization voltage, approx. 55 V AC, same phase position as voltage U/V on the power section	A3	3
SIN V	As SIN U, but phase position as the voltage V/W on the power section	C3	3
SIN W	As SIN U, but phase position as the voltage W/U on the power section	D3	3
0V	0V Regulator reference point	C8	3
+15	+15V Voltage supply	A8	3
-15	-15V Voltage supply	D8	3
+24	+24V Voltage supply	A8	3
-24	-24V Voltage supply	D6	3

9.3 Modulator My34

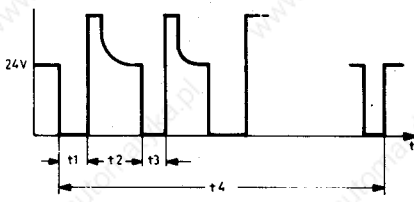
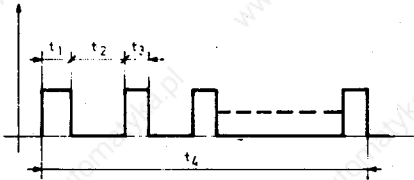
Designation	Function	ESE 1591		ESE 1593	
		sheet	pos.	sheet	pos.
Y4-1	Sinusoidal voltage approx. 20 V pp. 90° leading against voltage U/V (see fig. 5.10.1)	1	C5	3	C5
Y4-2	Sinusoidal voltage approx. 20 V pp. 90° lagging against voltage U/W (see fig. 5.10.1)	1	C4	3	C5
Y4-3	Reference voltage 2 nd Sinus modulator V (see fig. 5.10.2)	1	B5	3	C6
Y4-4	Sinusoidal voltage approx. 20 V pp. 90° leading against voltage U/V (see fig. 5.10.1)	1	C2	3	B5
Y4-5	Reference value 1 st Sinus modulator U (see fig. 5.10.2)	1	B1	3	B6
Y4-6	Sinusoidal voltage approx. 20 V pp. 90° lagging against voltage U/V (see fig. 5.10.1)	1	C1	3	B5
Y4-7	Max. ignition angle U (see fig. 5.10.1)	2	E1	—	—
Y4-8	Sum of all the pulses	2	D4	—	—
Y4-9	Max. ignition angle V (see fig. 5.10.1)	2	E4	—	—
Y4-10	Reference value 1 st Sinus modulator V (see fig. 5.10.2)	1	B4	3	C6
Y4-11	Reset signal for the ignition pulse chain: no reset: +15V reset : 0V	2	Dx	—	—
Y4-12	Max. ignition angle W (see fig. 5.10.1)	2	E6	—	—
Y4-13	Min. ignition angle V (see fig. 5.10.1)	2	E5	—	—
Y4-14	Min. ignition angle U (see fig. 5.10.1)	2	E1	—	—
Y4-15	Min. ignition angle W (see fig. 5.10.1)	2	E7	—	—
Y4-16	Sinusoidal voltage approx. 20 V pp. 90° leading against voltage W/U (see fig. 5.10.1)	1	C6	3	C5
Y4-17	Reference value 2 nd Sinus modulator U (see fig. 5.10.2)	1	B2	3	B6
Y4-18	Reference value 2 nd Sinus modulator W (see fig. 5.10.2)	1	B8	3	D6
Y4-19	Reference value 1 st Sinus modulator W (see fig. 5.10.2)	1	B7	3	C6
Y4-20	Sinusoidal voltage approx. 20 V pp. 90° leading against voltage W/U (see fig. 5.10.1)	1	C8	3	D5
Y5-1	Ignition pulse signal, frequency approx. 10 kHz 	3	D1	3	B8
Y5-2	Pulse generated by the logic 	2	B7	3	D7
Y5-3	As Y5-2	2	B5	3	C7
Y5-4	All ignition pulses	2	B2	3	E7

Designation	Function	ESE 1591		ESE 1593	
		sheet	pos.	sheet	pos.
Y5-5	Logic signal Suppression of 2nd pulses, 2nd pulse not suppressed: +15V 2nd pulse suppressed: 0V	2	C2	3	E7
Y5-6	As Y5-2	2	B1	3	B7
Y5-7	As Y5-1	3	D7	3	C8
Y5-8	+24 V - Supply voltage of the pulse transformers for the bridge MN	3	A1	3	D8
Y5-9	+24 V - Supply voltage of the pulse transformers for the bridge MP	3	A3	3	B8
Y5-10	As Y5-1	3	D5	3	C8
Y5-11	As Y5-1	3	D8	3	D8
Y5-12	As Y5-2	2	B1	3	C7
Y5-13	As Y5-2	2	B5	3	C7
Y5-14	As Y5-2	2	B7	3	D7
Y5-15	As Y5-1	3	D4	3	C8
Y5-16	As Y5-1	3	D2	3	B8

10 Layout of the terminals

The terminals can be simultaneously used as measuring points (2 mm test plugs)

I = Input Q = Output

10.1 Regulator card Ry34

Terminal marking	Function	I/Q	Max. voltage	Max. current	ESE 1590		ESE 1593	
					sheet	pos.	sheet	pos.
1	Actual value input	I	300V	approx. 3 mA	1	E1	1	E3
2	0V	—	—	—	1	E1	1	E3
3	+10V, short-circuit proof	Q	+10V	50 mA Incl. ter. 31	4	E5	1	C1
4	-10V, short-circuit proof	Q	-10V	50 mA Incl. ter. 22	4	E5	1	B1
5	n-reference value input	I	±10V	0,65 mA	1	B1	1	C1
6	Additional input n-regulator	I	±50V	0,65 mA	1	B1	1	C1
7	n _{min}	Q	—	—	1	C1	1	D1
8	0V	—	—	—	1	B1	1	D1
9	Input reference current value	I	±10V	0,2 mA	2	A1	2	E1
10	Output n-regulator (See note under 5.6)	Q	±10V	1 mA	1	E5	1	E6
11	Input current regulator	I	+10V	0,5 mA	2	A3	2	E2
12	Logic input for blocking	I	±15V	0,7 mA	3	C1	2	A1
13	Terminal for ammeter	Q	—	2 mA	2	E5	2	E2
14	Terminal for tachometer	Q	±10V	3 mA	1	E3	1	E5
15	External current limitation (-)	I	-10V	—	1	E5	1	E7
16	External current limitation (-)	Q	-10V	—	1	E6	1	E7
17	External current limitation (+)	I	+10V	—	1	E6	1	E8

Terminal marking	Function	I/Q	Max. voltage	Max. current	ESE 1590 sheet pos.		ESE 1593 sheet pos.	
18	External current limitation (+)	Q	+10V	—	1	E7	1	E7
19	+24V	Q	+24V	See 5.1	3	B1	1	B1
20	I-component n-regulator blocked Voltage = Enable	I	+15...24V	1,5...3,5 mA	1	A9	1	B1
21	Regulator enable Voltage = Enable	I	+15...24V	1,5...3,5 mA	3	D1	2	A5
22	-10V via R218	Q	-10V	50 mA Incl. cl. 4	1	E8	1	E6
25	Output decoupling amplifier for the armature voltage	Q	±10V	3 mA	2	E5	2	E5
26	Reference value enable Voltage = Enable	I	+15...24V	1,5...3,5 mA	4	A4	1	A1
27	Ramp function generator enable Voltage = Enable	I	+15...24V	1,5...3,5 mA	4	A7	1	A1
28	Input ramp function generator	I	±+10V	0,5 mA	4	A3	1	A1
29	Actuation delay compensation	Q	±10V	4 mA	4	D9	1	A1
30	Output ramp function generator	Q	±10V	4 mA	4	B9	1	B1
31	+10V via R217	Q	+10V	50 mA Incl. cl. 3	1	E7	1	E6
32	Speed indication with static signal 0V → n = 0 +24V → n ≠ 0	Q	+24V	10 mA	6	D9	1	E8
33/34	Speed indication with potential-free contact Opened n = 0 Closed n ≠ 0	Q	250V ~	3A	6	D9	1	E9
35/36	Monitoring of the control circuits potential-free contact Closed = OK	Q	250V ~	3A	5	A6	2	A9
37	Monitoring of the control circuits +24V = OK	Q	+24V	10 mA	5	A5	2	A99
+24	Supply voltage for external cards	Q	+24V	See 5.1	5	B9	2	E6
-15	Supply voltage for external cards	Q	-15V	See 5.1	5	B9	2	E7
+15	Supply voltage for external cards	Q	+15V	See 5.1	5	A9	2	E6
0V	Regulator reference point	—	—	—	1	E7	1	D1
					5	A9	2	E7

10.2 Py34-... Cards

Terminal marking	Function	I/Q	Max. voltage	Max. current (power)	ESE 1603 ESE 1635 ESE 1637 sheet pos.	
1U, 1V, 1W	Regulator supply (remove only if power and regulator sections are fed separately)	I	500V + 10%	40 VA	E4	3 A5
3U, 3V	Fan supply at 110A ≥ I _{dN} ≥ 500A	I	220/240V 50/60 Hz	0,12 A* 0,24 A**	E7	4 A6
61, 62	Thermal monitoring of the heat sinks Potential-free break contact at 110A ≥ I _{dN} ≥ 500A	Q	250V ~	2A	E8	4 A6

* At 110A ≤ I_{dN} ≤ 185A

** At 280A ≤ I_{dN} ≤ 500A

10.3 Armature circuit

Terminal marking	Function	I/Q	Max. voltage	Max. current	ESE 1593 sheet pos.
U, V, W	Incoming supply, armature circuit A.C. side (U_{LN})	I	$3 \times 415V + 10\%$ $3 \times 500V + 10\%$	$I_{dN} \cdot 0,82 \cdot F$	4 A5
C, D	Armature circuit, d.c. side (U_{dN}) Clockwise rotation: C → +, D → - Anti-clockwise rotation: C → - D → +	Q	440V* 520V**	I_{dN}	4 E4 4 E6
3U, 3V	Fan supply***	I	220V, 50Hz	2,3A	4. 3 A7
31U	Fan supply*** (at $U_{LN} = 230/240V$ and 60Hz instead of terminal 3U)	I	240V 50/60Hz	2,3A	4. 3 A6
61/62	Thermal monitoring of the heat sinks*** Potential-free break contact	Q	250V ~	2A	4. 3 A6
83/84	Fuse monitoring*** Potential-free break contact open Open = faulty	Q	250V ~	2A	4. 3 A6

* at TPY3-415/... ** at TPY3-500/... *** at $I_{dN} \geq 800A$

10.4 Field supply Fy...

Terminal marking	Function	I/Q	Max. voltage	Max. current	ESE 1616 ESE 1638	ESE 1593 sheet pos.
2U, 2V	Incoming field supply a.c.	I	415V + 10%	4A...25A	C1, C3, C7, A2	4 A7
2C, 2D	Field supply d.c. side 2C → +, 2D → -	Q	375V + 10%	4A...25A	C3, C6, C9 D1, D2	4 E7
53, 54	Contact field current relay	Q	250V	3A	D3, D6, D9 C8	4 E9

11. LED's

11.1 Regulator card Ry34

Designation	Colour	LED lights up if:	ESE 1590 sheet pos.	ESE 1593 sheet pos.
RSH	Red	Short-circuit or overloading of the reference value	4 C1	2 A7
AL	Red	RSH and/or AR and/or AF indicate a fault = Collective fault indication	5 B3	2 A8
AR	Red	Fuse blown on regulator supply Mains under-voltage - Supply voltage overloaded	5 C4	2 B8
AF	Red	Fuse blown on a.c. side power section at I_{dN} up to 500A and/or protective circuit	5 A3	2 B8
SI	Red	Pulse block	3 A9	2 B6
± 15	Green	±15V regulator supply available	5 A8	2 E7
I_{dN}	Yellow	Motor working on current limitation	1 D8	1 D6
$I_A = 0$	Yellow	Armature voltage = 0	3 A5	2 C2
$n = 0$	Yellow	Speed = 0 (Switching threshold potentiometer "n = 0")	6 D6	1 E8
BAG	Yellow	Generator blocked	4 A9	1 A4
BLG	Yellow	Regulator blocked	3 E5	2 C6
MN	Yellow	Bridge for negative current (torque) direction in operation	3 C9	2 A6
MP	Yellow	Bridge for positive current (torque) direction in operation	3 B9	2 B6

11.2 Modulator My34

Designation	Colour	LED lights up if:	ESE 1591	ESE 1593 sheet pos.
UVW	Yellow	Clockwise field at terminals 1U, 1V, 1W	2 B8	3 D7

11.3 Field supply Fy30

Note: Only if $I_{dN} \geq 800A$

Designation	Colour	LED lights up if:	ESE 1638	ESE 1593 sheet pos.
FL	Yellow	No field current	D6	4.3 D9

12 Potentiometers

12.1 Regulator card Ry34

Designation	Function	ESE 1590 sheet pos.	ESE 1593 sheet pos.
n_{max}	Set maximum speed	1 C1	1 D3
i_n	I-amplification n-regulator I-component increases with clockwise rotation	1 C9	1 B5
n_{min}	Setting of a minimum speed	1 C1	1 D1
p_n	P-amplification n-regulator P-component increases with clockwise rotation	1 C5	1 D6
d_n	D-amplification n-regulator D-component increases with clockwise rotation	1 C6	1 C6
I_{AD}	Calibration of the power dip matching	2 B4	2 D4
i_l	I-amplification I-regulator I-component increases with clockwise rotation	2 A5	2 D4
p_l	P-amplification I-regulator P-component increases with clockwise rotation	2 C4	2 D3
I_{AN}	Calibration of an external armature current ammeter	2 E4	2 E2
DT_N	Calibration of an external tachometer	1 D2	1 D4
$-I_{dN}$	Setting of the internal current limitation for the positive torque direction	1 E6	1 E6
$+I_{dN}$	Setting of the internal current limitation for the negative torque direction	1 E7	1 E7
Rxl	Calibration Rxl-compensation and EMF anticipatory control	2 E8	2 E6
$n = 0$	Setting of the switching threshold for the standstill control	6 C3	1 B6
-a	Integration time for clockwise driving and anti-clockwise braking. Range dependent on R142 A, B, C	4 C7	1 B3
+a	Integration time for clockwise braking and anti-clockwise driving. Range dependent on R141 A, B, C	4 C6	1 B2
OFFSET n	Offset adjustment n-regulator	1 C4	1 D5
OFFSET 2	Offset adjustment $N_{act} = 0$ -recognition	6 C1	1 B5
OFFSET 3	Offset adjustment $N_{ref} = 0$ -recognition	6 A3	1 A5

12.2 Card Py34-...

Designation	Function	ESE 1603 ESE 1635 ESE 1637	ESE 1593 sheet pos.
TA	Calibration of the rated armature current (see 2.3)	A9	4 C1



13 **Micro switch**
13.1 **Regulator card Ry34**

Designation	Function	ESE 1590		ESE 1593																	
		sheet	pos.	sheet	pos.																
SW3-1...8	Matching of the actual value input to the maximum actual value voltage (see 5.3) <table border="1" style="margin-left: 20px;"> <thead> <tr> <th>Actual value</th> <th>SW3</th> </tr> </thead> <tbody> <tr> <td>5... 10V</td> <td>1...8 ON</td> </tr> <tr> <td>10... 18V</td> <td>1...7 ON, 8 OFF</td> </tr> <tr> <td>18... 35V</td> <td>1...6 ON, 7...8 OFF</td> </tr> <tr> <td>35... 65V</td> <td>1...5 ON, 6...8 OFF</td> </tr> <tr> <td>65...110V</td> <td>1...4 ON, 5...8 OFF</td> </tr> <tr> <td>110...180V</td> <td>1...2 ON, 3...8 OFF</td> </tr> <tr> <td>180...300V</td> <td>1...8 OFF</td> </tr> </tbody> </table> Armature voltage regulation: SW3-1...8 ON	Actual value	SW3	5... 10V	1...8 ON	10... 18V	1...7 ON, 8 OFF	18... 35V	1...6 ON, 7...8 OFF	35... 65V	1...5 ON, 6...8 OFF	65...110V	1...4 ON, 5...8 OFF	110...180V	1...2 ON, 3...8 OFF	180...300V	1...8 OFF	1	D1	1	D3
		Actual value	SW3																		
5... 10V	1...8 ON																				
10... 18V	1...7 ON, 8 OFF																				
18... 35V	1...6 ON, 7...8 OFF																				
35... 65V	1...5 ON, 6...8 OFF																				
65...110V	1...4 ON, 5...8 OFF																				
110...180V	1...2 ON, 3...8 OFF																				
180...300V	1...8 OFF																				
SW4-1	Bridging the I-component of the speed regulator (see 5.6) ON : I-component bridged OFF: I-component not bridged	1	C8	1	B6																
SW4-2	D-component of the speed regulator (see 5.6) ON : D-component switched in OFF: D-component switched out	1	C6	1	B6																
SW4-3	Power dip compensation (see 5.7) ON : Compensation switched in OFF: Compensation switched out	2	A4	2	D4																
SW4-4	Bridging the I-component of the current regulator (see 5.7) ON: I-component bridged (P-behaviour) OFF: I-component not bridged	2	B5	2	C4																
SW4-5	Connection n-regulator/rectifier stage (see 5.8)	1	B9	1	C7																
SW4-6	Connection rectifier stage/I-regulator (see 5.8)	2	B3	2	C3																
SW4-7	Forced control of the modulator ON: All pulses at α_{max}	2	B6	2	C5																
SW4-8	To be used with SW4-2 SW4-2 OFF → SW4-8 ON SW4-2 ON → SW4-8 OFF	1	C4																		
SW5-1	ON : External speed indication as voltmeter (see 5.6) OFF: External speed indication as ammeter	1	E2	1	E5																
SW5-2	Connection reference value generator/n-regulator	4	B9	1	A4																
SW5-3	Current limitation for the positive current (torque) direction (see 5.5) ON: Internal OFF: External	1	E6	1	E7																
SW5-4	Current limitation for the positive current (torque) direction (see 5.5) ON: Internal OFF: External	1	E7	1	E8																
SW5-5	Monitoring of a.c. fuses in the power section for devices from 800A and the protective circuit "AF" (see 5.11) ON: Inactive OFF: Active	5	A1	2	B9																
SW5-6	n-regulator adaptation (see 5.6) ON : When n-reference value = 0 and n-actual value = 0 the I-component of the speed regulator is blocked OFF: The above mentioned function becomes superfluous	6	A5	1	A8																
SW5-7	n-regulator adaptation (see 5.6) ON : The function described under SW5-8 is cancelled only if the n-reference value \neq 0 OFF: Behaviour as described for SW5-8	6	B7	1	A7																
SW5-8	n-regulator adaptation (see 5.6) ON : When the n-reference value = 0 and the n-actual value = 0, R27 is switched in parallel with the regulator feedback OFF: The above mentioned function becomes superfluous	6	A7	1	A7																

Modification:

Designation	Function	ESE 1590		ESE 1593																																												
		sheet	pos.	sheet	pos.																																											
SW7-1...5	Matching of the decoupling amplifier (see 5.3.2)	2	C6	2	D6																																											
						<table border="1"> <thead> <tr> <th rowspan="2">U_{LN}</th> <th colspan="5">SW7</th> </tr> <tr> <th>1</th> <th>2</th> <th>3</th> <th>4</th> <th>5</th> </tr> </thead> <tbody> <tr> <td>230/240V</td> <td>x</td> <td>-</td> <td>-</td> <td>-</td> <td>-</td> </tr> <tr> <td>380V</td> <td>-</td> <td>x</td> <td>-</td> <td>-</td> <td>-</td> </tr> <tr> <td>415V</td> <td>-</td> <td>-</td> <td>x</td> <td>-</td> <td>-</td> </tr> <tr> <td>440/460V</td> <td>-</td> <td>-</td> <td>-</td> <td>x</td> <td>-</td> </tr> <tr> <td>480/500V</td> <td>-</td> <td>-</td> <td>-</td> <td>-</td> <td>x</td> </tr> <tr> <td>Others*</td> <td>-</td> <td>-</td> <td>-</td> <td>-</td> <td>-</td> </tr> </tbody> </table>		U _{LN}	SW7					1	2	3	4	5	230/240V	x	-	-	-	-	380V	-	x	-	-	-	415V	-	-	x	-	-	440/460V	-	-	-	x	-	480/500V	-	-	-	-	x
U _{LN}	SW7																																															
	1	2	3	4	5																																											
230/240V	x	-	-	-	-																																											
380V	-	x	-	-	-																																											
415V	-	-	x	-	-																																											
440/460V	-	-	-	x	-																																											
480/500V	-	-	-	-	x																																											
Others*	-	-	-	-	-																																											
*Note maximum mains voltage, fit R90																																																
SW7-6	RFG enable ON : Enable with voltage at terminals 21 and 27 OFF: Enable with voltage at terminal 27	4	A8	1	A4																																											

13.2 Regulator supply Sy3

Note: The three switches must have the same respective positions.

Designation	Function	ESE 1592		ESE 1593									
		sheet	pos.	sheet	pos.								
SW-U SW-V SW-W	Matching of the regulator supply to the mains voltage	B2 C2 D2	3 3 3	B1 B2 B3									
						<table border="1"> <thead> <tr> <th>U_{LN}</th> <th>Switch position</th> </tr> </thead> <tbody> <tr> <td>230V -10% ... 240V +10%</td> <td>230/240</td> </tr> <tr> <td>380V ±10%</td> <td>380</td> </tr> <tr> <td>415V ±10%</td> <td>415</td> </tr> <tr> <td>440V -10% ... 460V +10%</td> <td>440/460</td> </tr> <tr> <td>480V -10% ... 500V +10%</td> <td>480/500</td> </tr> </tbody> </table>		U _{LN}	Switch position	230V -10% ... 240V +10%	230/240	380V ±10%	380
U _{LN}	Switch position												
230V -10% ... 240V +10%	230/240												
380V ±10%	380												
415V ±10%	415												
440V -10% ... 460V +10%	440/460												
480V -10% ... 500V +10%	480/500												

13.3 Modulator My34

Designation	Function	ESE 1591		ESE 1593	
		sheet	pos.	sheet	pos.
SW6-2...4	Matching to the mains frequency 50 Hz : SW6-2 / 3 / 4 OFF 60 Hz : SW6-2 / 3 / 4 ON (see 2.1)	1	E3	3	C4
		1	E1	3	B4
		1	E7	3	D4

13.4 Field supply Fy30

Note: Only with devices from 800A

Designation	Function	ESE 1638		ESE 1593	
		sheet	pos.	sheet	pos.
SW10	Matching to the field current (see 2.4)	A3	4.3	D8	

13.5 Switch positions as supplied

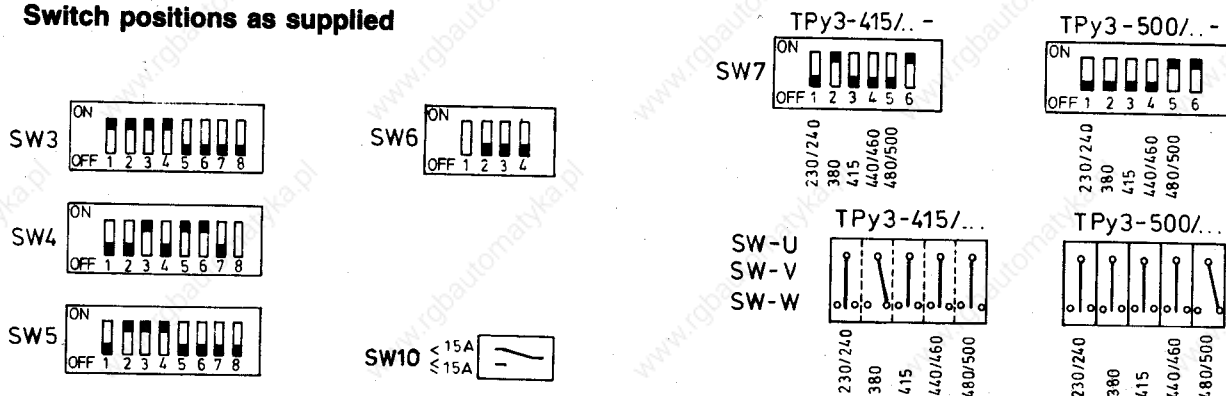

14 Bridges, calibration elements

14.1 Regulator card Ry34

Designation	Function	Standard	ESE 1590		ESE 1593	
			sheet	pos.	sheet	pos.
CV3	Enable I-component n-regulator (see 5.6)	Fitted	1	A9	1	B2
C2a	Input filter term. 6 n-reference value (see 5.4)	Not fitted	1	B2	1	D3
C3a	Input filter term. 5 n-reference value (see 5.4)	Not fitted	1	B1	1	C3
C4a	Input filter term. 1 n-actual value (see 5.3)	Not fitted	1	C2	1	D4
C11a, C11b	I-component of the n-regulator (see 5.6)	Not fitted	1	C8	1	B6
C14a	Input filter current regulator (see 5.7)	Not fitted	2	C2	2	D2
C15a	Input filter term. 11, I-reference value (see 5.7)	Not fitted	2	B3	2	E3
C67	D-component n-actual value (see 5.3)	Not fitted	1	C2	1	D4
R21	Input resistance n-reference value, i.e., n-regulator feedback (see 5.4.4)	22 k Ω	1	B2	1	C3
R27	R27 is switched in parallel with SW5-8 = ON when n-reference value = 0 and n-actual value of the n-regulator feedback = 0 (see 5.6)	Bridge	1	B5	1	C5
R37	P-component of the n-regulator (see 5.6)	68 k Ω	1	B5	1	B5
R75	P-component of the I-regulator (see 5.7+6.4.1.1)	12 k Ω	2	B4	2	C3
R76	Power dip compensator (see 5.7+6.4.1.1)	470 k Ω	2	A4	2	D4
R83	I-component of the I-regulator (see 5.7+6.4.1.1)	10 k Ω	2	A5	2	D4
R90	Matching of the decoupling amplifier (see 5.3.2)	Not fitted	2	C6	2	D5
R141A R141B R141C	Time-determining resistors of the ramp function generator for clockwise driving and anti-clockwise braking (see 5.4.1)	4,7 M Ω 1,2 M Ω 220 k Ω	4	B7	1	B3
R142A R142B R142C	Time-determining resistors of the ramp function generator for clockwise driving and anti-clockwise braking (see 5.4.1)	4,7 M Ω 1,2 M Ω 220 k Ω	4	C7	1	A3
R149	Input resistor for the n-reference value = 0-recognition when using term. 6 (see 5.6)	Bridge	6	B1	1	A5
R180	Time-determining resistor for the n = 0-indication and time delay when switching R27 in parallel with the n-regulator feedback (see 5.6+5.3.3)	47 k Ω	6	C5	1	B7
R185	Time-determining resistor when switching R27 in parallel with the n-regulator feedback (see 5.6)	47 k Ω	6	D7	1	A7
R217	Economy resistor from term. 31 to +10V	4,7 k Ω	1	E7	1	E6
R218	Economy resistor from term. 22 to -10V	4,7 k Ω	1	E8	1	E6
R220	D-component n-actual value (see 5.3)	Not fitted	1	C2	1	D4

14.2 Py34... Cards

Designation	Function	Standard	ESE 1603		ESE 1593	
			ESE 1635	ESE 1637	sheet	pos.
CV-U CV-V CV-W	Internal connection of the incoming supplies of power and regulator section (see 2.1)	Bridge Bridge Bridge		E4	4	B3
R5	Calibration of the current range (see 2.3)	Not fitted		A9	4	D1

14.3 Field supply Fy30

Note: Only with devices from 800A

Designation	Function	Standard	ESE 1638	ESE 1593 sheet pos.
R1	Determination of the switching point of the field current relay	27 Ω	D3	4. 3 D9
R2		27 Ω		
R3		Not fitted	D4	
R4		Not fitted		

15 Schematic and circuit diagram

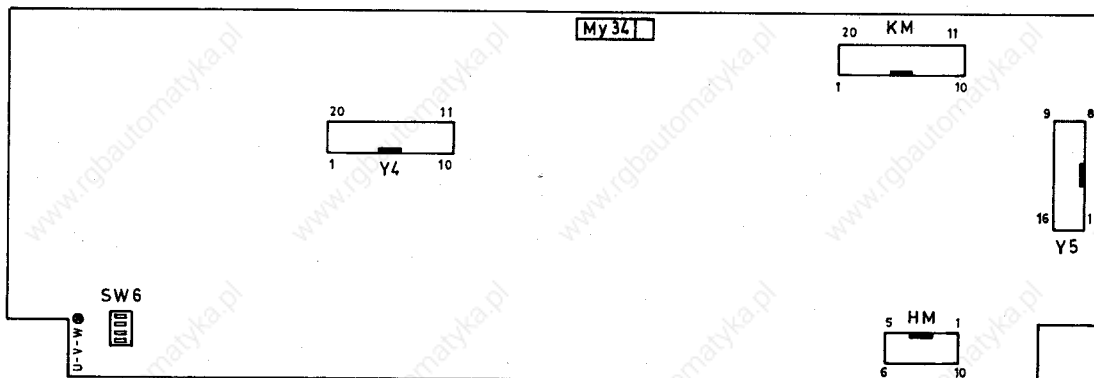
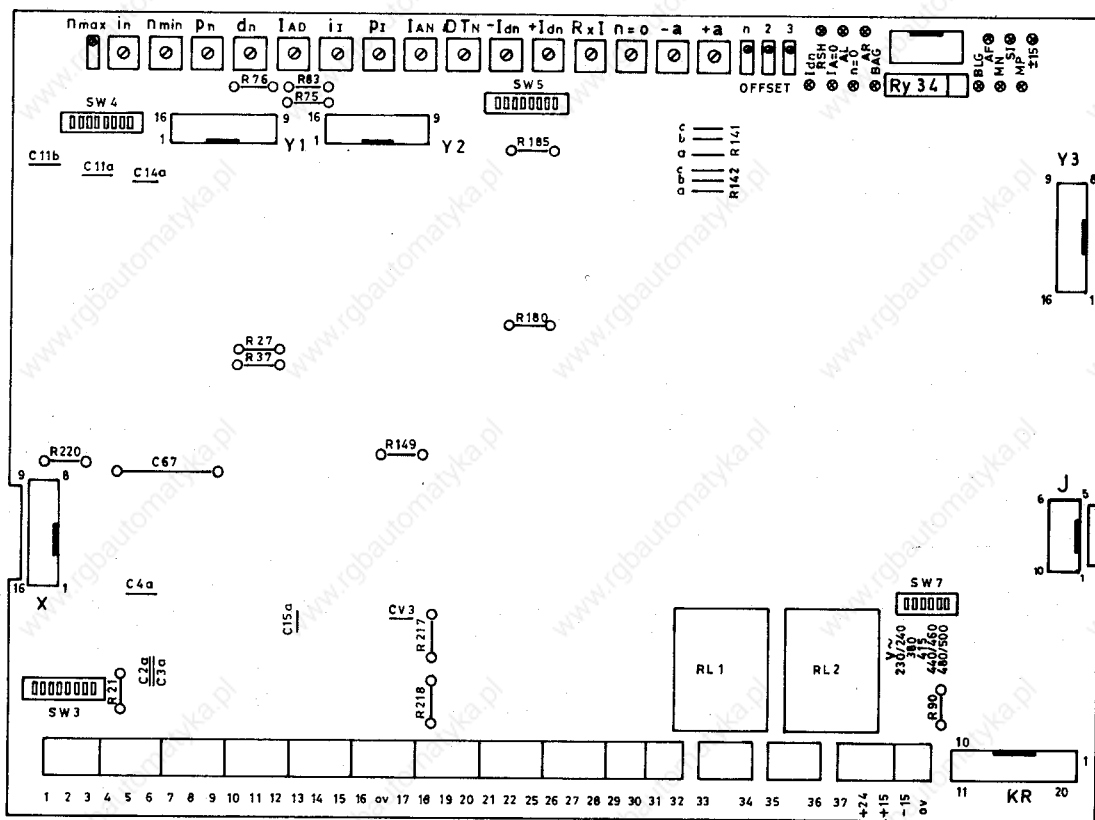

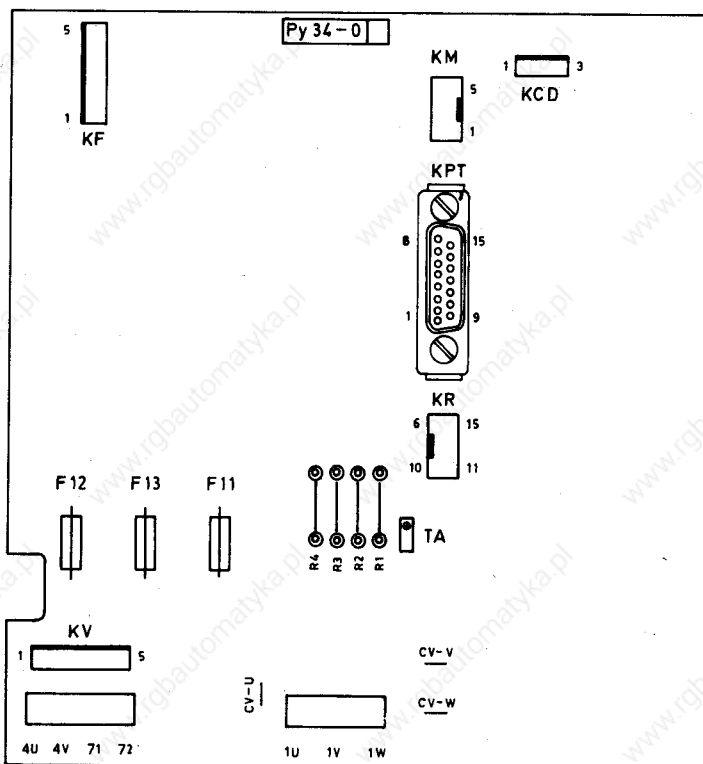
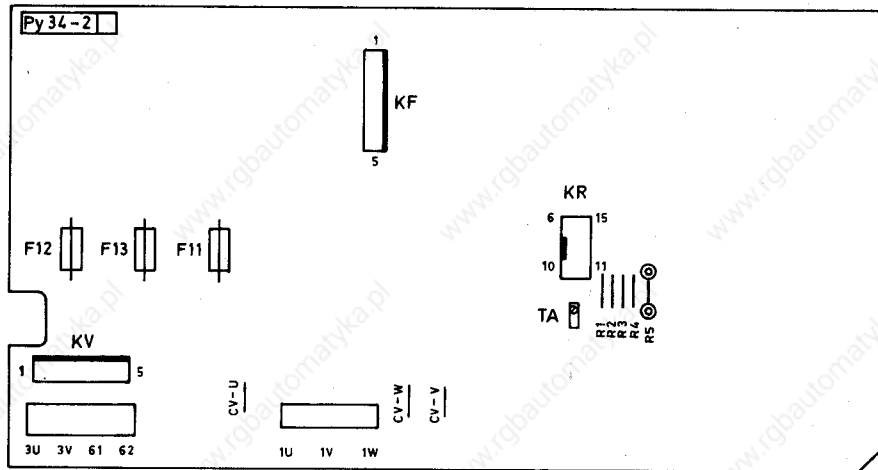
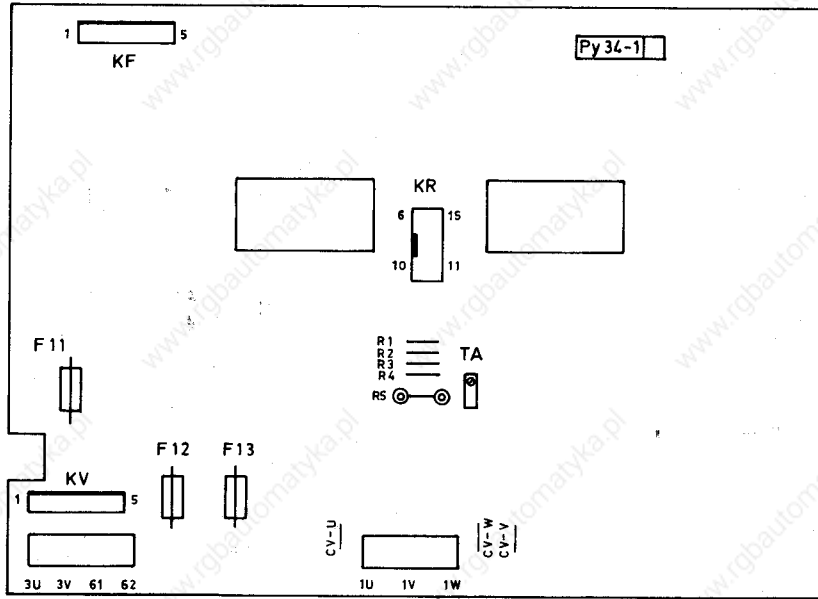

Modification:

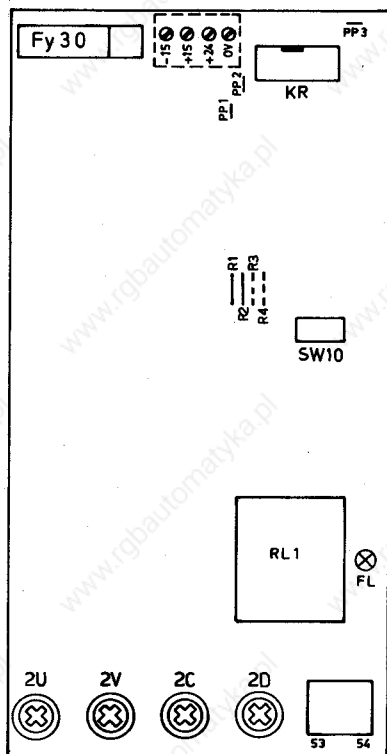
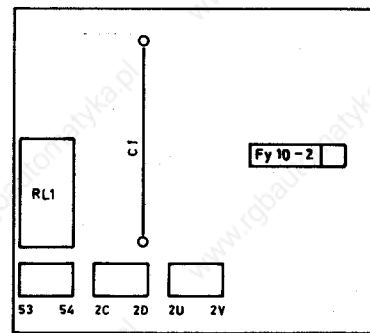
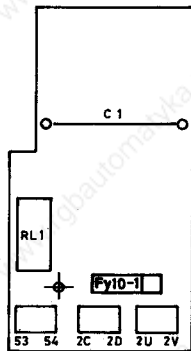
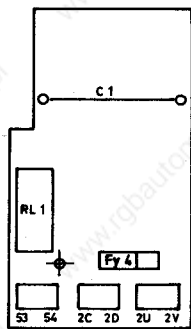
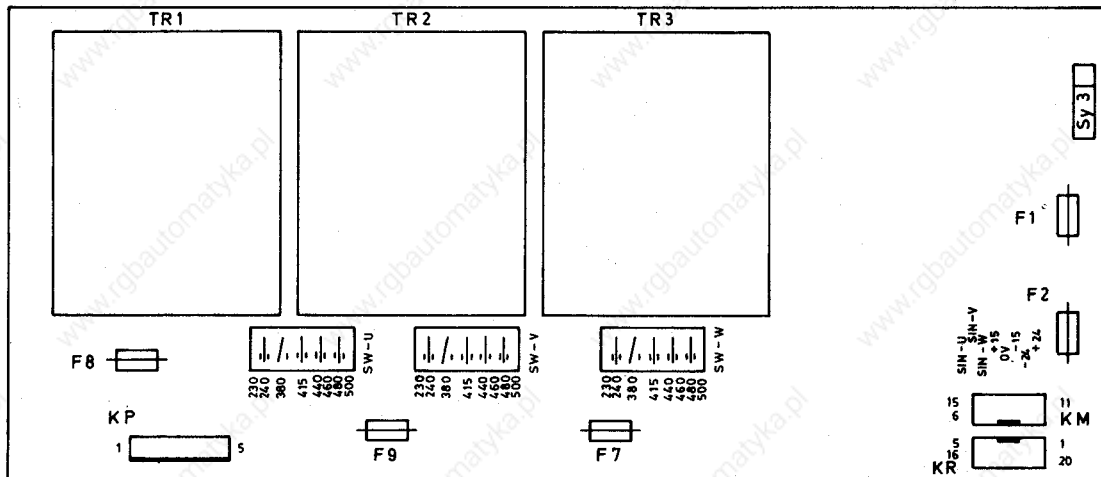

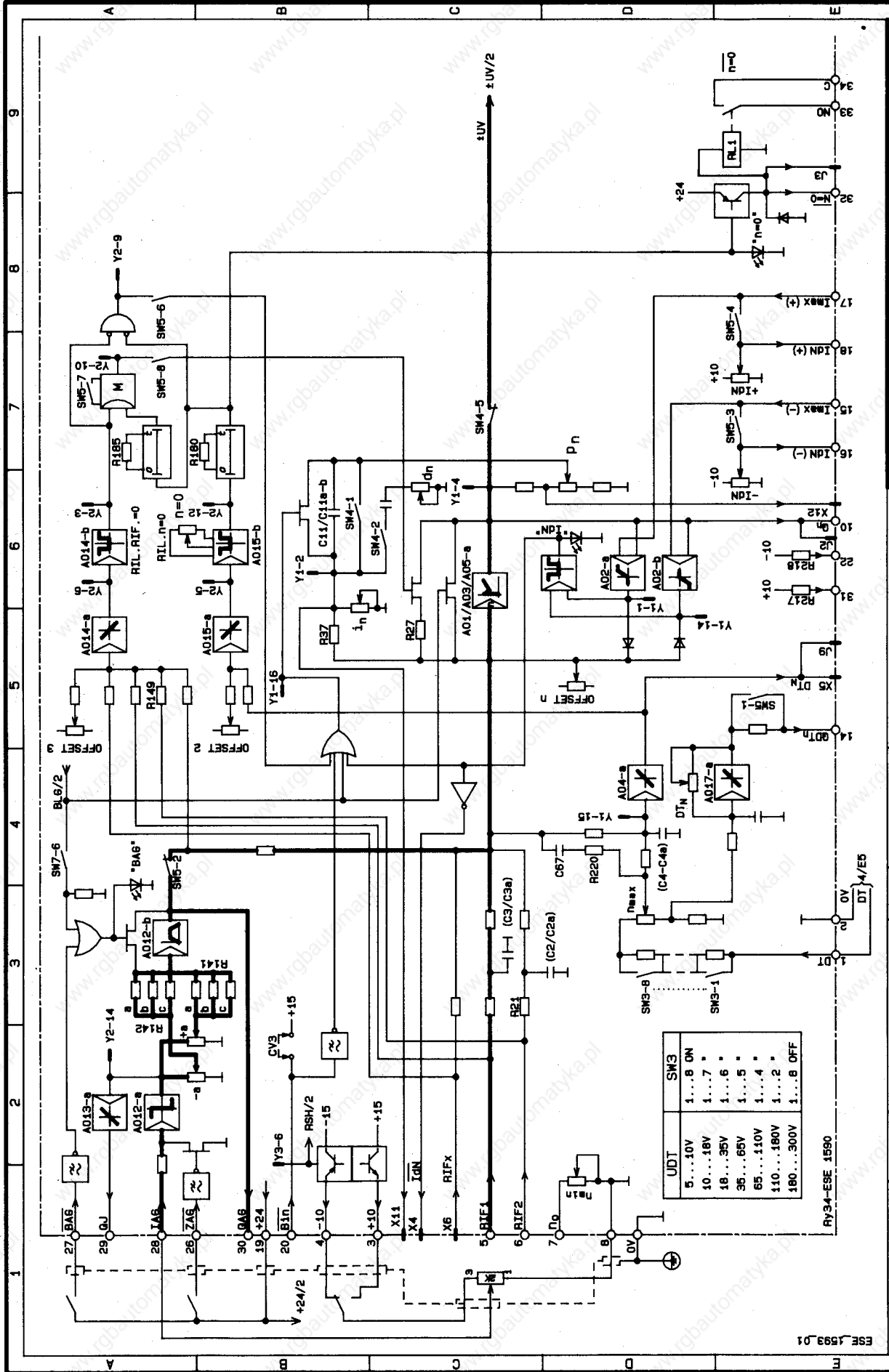

ESF 1593 01

RY34-ESE 1590

TPy3-415/440-20...2000L-4B
TPy3-500/520-20...2000L-4B

MOD.	DATA	MOD.	DATA	DESCRIZIONE

MOD.	DATA	DESCRIZIONE

MOD.	DATA	DESCRIZIONE

TPy3-415/440-20...2000L-4B
TPy3-500/520-20...2000L-4B
Date 20-9-84
KLÖCKNER-MOELLER
ESF 1593

