

Ordering information

Example: 56 series plug-in relay, 2 CO (DPDT), 12 V DC coil, lockable test button and mechanical indicator.

5 6 . 3	2 . 9 .	0 1 2 .	0	0	4	0
<p>Series _____</p> <p>Type _____</p> <p>3 = Plug-in</p> <p>4 = PCB</p> <p>No. of poles _____</p> <p>2 = 2 pole, 12 A</p> <p>4 = 4 pole, 12 A</p> <p>Coil version _____</p> <p>8 = AC (50/60 Hz)</p> <p>9 = DC</p> <p>Coil voltage _____</p> <p>See coil specifications</p>		<p>A: Contact material</p> <p>0 = Standard AgNi</p> <p>2 = AgCdO</p> <p>4 = AgSnO₂</p> <p>B: Contact circuit</p> <p>0 = CO (nPDT)</p> <p>3 = NO (nPST), ≥ 1.5 mm contact gap</p>		<p>D: Special versions</p> <p>0 = Standard</p> <p>1 = Wash tight (RT III) for 56.42 and 56.44 only</p> <p>6 = Rear flange mount (4 pole only)</p> <p>8 = Rear 35 mm rail mount (4 pole only)</p> <p>For other mounting options see page 6</p> <p>C: Options</p> <p>0 = None</p> <p>2 = Mechanical indicator</p> <p>3* = LED (AC)</p> <p>4 = Lockable test button+mechanical indicator</p> <p>5* = Lockable test button + LED (AC)</p> <p>54* = Lockable test button + LED (AC) + mechanical indicator</p> <p>6* = Double LED (DC non-polarized)</p> <p>7* = Lockable test button + double LED (DC non-polarized)</p> <p>74* = Lockable test button + double LED (DC non-polarized) + mechanical indicator</p> <p>8* = LED + diode (DC, polarity positive to pin 7) for 56.32 only</p> <p>9* = Lockable test button + LED + diode (DC, polarity positive to pin 7) for 56.32 only</p> <p>94* = Lockable test button + LED + diode (DC, polarity positive to pin 7) + mechanical indicator for 56.32 only</p> <p>* Options not available for 220 V DC and 400 V AC versions.</p>		

Selecting features and options: only combinations in the same row are possible.
Preferred selections for best availability are shown in **bold**.

Type	Coil version	A	B	C	D
56.32	AC	0 - 2 - 4	0	0 - 2 - 3 - 4 - 5	0
	AC	0 - 2 - 4	0	54	/
	AC	0 - 2 - 4	3	0 - 3 - 5	0
	DC	0 - 2 - 4	0	0 - 2 - 4 - 6 - 7 - 8 - 9	0
	DC	0 - 2 - 4	0	74 - 94	/
56.34	AC	0 - 2 - 4	0	0 - 2 - 3 - 4 - 5	0 - 6 - 8
	AC	0 - 2 - 4	0	54	/
	DC	0 - 2 - 4	0	0 - 2 - 4 - 6 - 7	0 - 6 - 8
	DC	0 - 2 - 4	0	74	/
56.42	DC	0 - 2 - 4	0	0	0 - 1
	AC	0 - 2 - 4	0 - 3	0	0 - 1
56.44	AC-DC	0 - 2 - 4	0	0	0 - 1

Special versions for Rail Applications on request

Descriptions: options and special versions

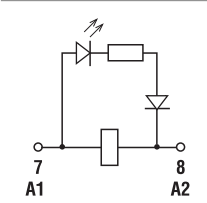
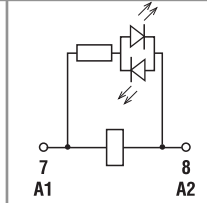
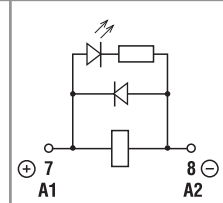
		
<p>C: Option 3, 5, 54 LED (AC)</p>	<p>C: Option 6, 7, 74 Double LED (DC non-polarized)</p>	<p>C: Option 8, 9, 94 LED + diode (DC, polarity positive to pin 7) - (56.32 only)</p>

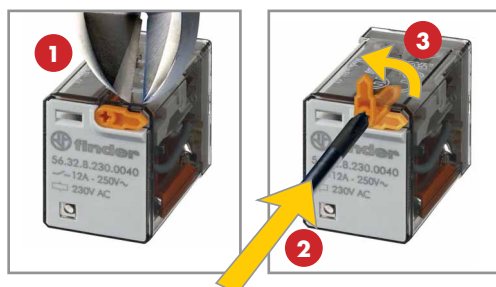

Lockable test button and mechanical flag indicator (0040, 0050, 0054, 0070, 0074, 0090, 0094)

The dual-purpose Finder test button can be used in two ways:
Case 1) The plastic pip (located directly above the test button) remains intact. In this case, when the test button is pushed, the contacts operate. When the test button is released the contacts return to their former state.

Case 2) The plastic pip is broken-off (using an appropriate cutting tool). In this case, (in addition to the above function), when the test button is pushed and rotated, the contacts are latched in the operating state, and remain so until the test button is rotated back to its former position.

In both cases ensure that the test button actuation is swift and decisive.

Technical data

*Only in applications where over voltage category II is permitted. In applications of over voltage category III: Micro-disconnection.

A

Insulation according to EN 61810-1		2 CO - 4 CO		2 NO	
Nominal voltage of supply system	V AC	230/400		230/400	
Rated insulation voltage	V AC	250	400	250	400
Pollution degree		3	2	3	2
Insulation between coil and contact set					
Type of insulation		Basic		Basic	
Overvoltage category		III		III	
Rated impulse voltage	kV (1.2/50 µs)	4		4	
Dielectric strength	V AC	2,500		2,500	
Insulation between adjacent contacts					
Type of insulation		Basic		Basic	
Overvoltage category		III		III	
Rated impulse voltage	kV (1.2/50 µs)	4		4	
Dielectric strength	V AC	2,500		2,500	
Insulation between open contacts					
Type of disconnection		Micro-disconnection		Full-disconnection*	
Overvoltage category		—		II	
Rated impulse voltage	kV (1.2/50 µs)	—		2.5	
Dielectric strength	V AC/(1.2/50 µs)	1,000/1.5		2,000/3	
Conducted disturbance immunity					
Burst (5...50) ns, 5 kHz, on A1 - A2		EN 61000-4-4		level 4 (4 kV)	
Surge (1.2/50 µs) on A1 - A2 (differential mode)		EN 61000-4-5		level 4 (4 kV)	
Other data					
Bounce time: NO/NC	ms	1/4 (changeover)		3/— (normally open)	
Vibration resistance (10...150 Hz): NO/NC	g	17/14			
Shock resistance NO/NC	g	20/14			
Power lost to the environment	without contact current	W	1 (56.32, 56.42)		1.3 (56.34, 56.44)
	with rated current	W	3.8 (56.32, 56.42)		6.9 (56.34, 56.44)
Recommended distance between relays mounted on PCB	mm	≥ 5			

Contact specification

F 56 - Electrical life (AC) v contact current

2 - 4 pole relays

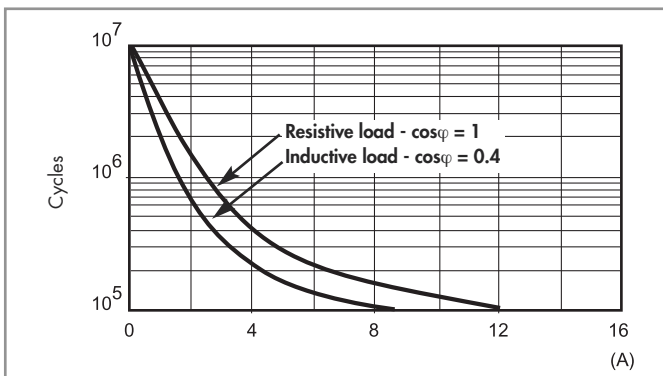

H 56 - Maximum DC1 breaking capacity

Changeover version

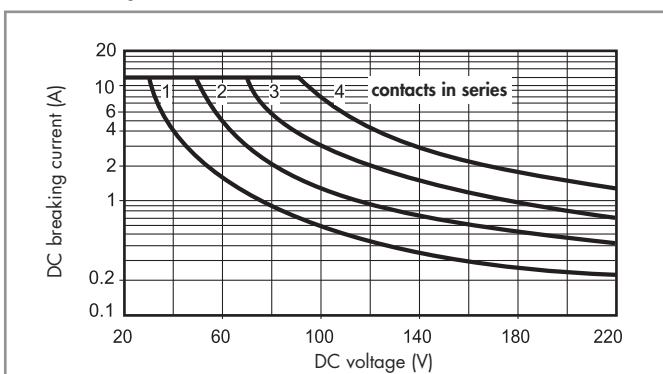

H 56 - Maximum DC1 breaking capacity

Normally open version

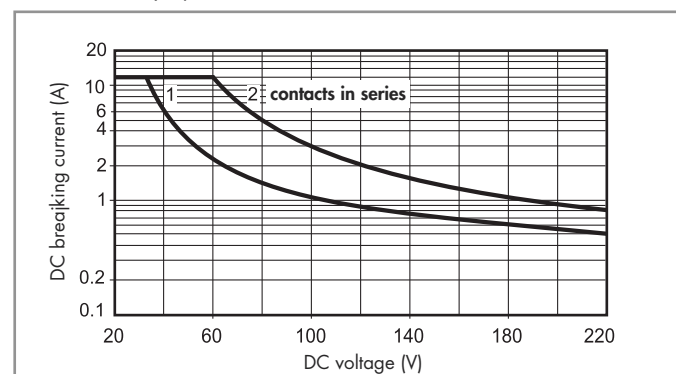

- When switching a resistive load (DC1) having voltage and current values under the curve, an electrical life of $\geq 100 \cdot 10^3$ can be expected.
 - In the case of DC13 loads, the connection of a diode in parallel with the load will permit a similar electrical life as for a DC1 load.
- Note: the release time of the load will be increased.