

DESIGN CONSIDERATIONS & APPLICATIONS

Warm-Up Time

The Warm-Up Time for the INIR sensor is 45 seconds after each power “ON” or every time when we are changing from Configuration to Normal/Engineering Mode. During this time data are not valid. Please read Fault codes in Application Note 1, “Integrated IR Protocol & Calibration”

The Warm-Up time is not including the period that the sensor needs to reach the ambient temperature. The sensor though is capable of producing readings during the Warm-Up but with a much higher error than specifications.

Calibration

For calibration process please read the appropriate Application Note 1, “Integrated IR Protocol & Calibration”. For optimum performance please use following cylinders:

INIR-RF-R32
100% Nitrogen for Zero calibration
7%v.v R32 balanced Nitrogen for High Span Cal.

Always do Zero Calibration first followed by High Span.

Gas Flow Rate

For valid evaluation and to keep tests consistent it is recommended to use 450 – 500 cc/min. flow rate to minimize any effects due to pressure variations in the INIR.

Digital Interface/Communication

In terms of the Software implementation, we will need a way to read the Digital Output by using a Microcontroller (MCU) or a Personal Computer (PC) is required. The Software with the Evaluation Kit is compatible with Windows Operating System only and at the moment is not possible to read the Analogue output by using the Evaluation Software.

Faults Monitoring/Error States

The Error monitoring and Fault generation happens every second transmitted by the UART. Regularly check all the Faults generated from the INIR to ensure errorless communication and rise appropriate alarms depending on the Fault code. For further information on the different Faults and how to translate them, please read the Application Note 1, “Integrated IR Protocol & Calibration”.

Analogue Output

The Analogue Output is updated every one second. Analogue voltage is directly related with the Concentration.

Condensation, Dust & Extreme Conditions

Using the INIR in extreme environmental conditions may affect its performance. Typically, the module has a high corrosion resistance and temperature compensated linearized output. The INIR implements an Condensation Compensation Algorithm to minimize the effect especially after power “ON”, eliminating the problem with false alarm. The Sensor can withstand multiple thermal shocks that don't exceed 1.3°C/min temperature slopes. In applications like mining where dust or other particles are present is recommended to use a dust filter firmly attached to the inlet of the INIR Gas Sensor. The filter tends to increase response times T90, T10 and T50 therefore ensure correct installation and evaluation to comply with regulations in your country. If your device is intended to be used in a hazardous environment, please seek advice from a certification body.

Pressure Compensation

The INIR will definitely need pressure compensation irrelevant if the pressure is within the operating pressure. Re-Zero the INIR Gas Sensor under operating conditions is recommended; this will minimize the pressure effects, temperature differential effects but will not eliminate the weather effects like extreme wind velocity, rain or lightning.

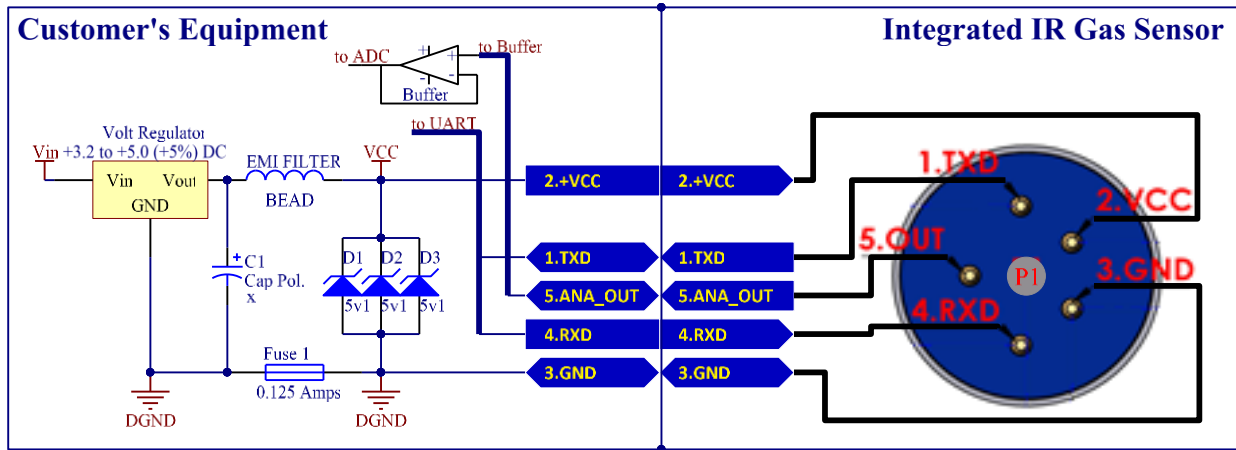

Fig. 1 -Example schematic for Interfacing Integrated IR (INIR)

TYPICAL PERFORMANCE CHARACTERISTICS

(All Characteristics are related to a calibrated sensor and conditions, Temperature 20°C, Relative Humidity 10%RH, Pressure 101kPa, 500 to 1000 ml/min Gas Flow, Averaging of 20 values, unless otherwise stated.)

Test	INIR-RF-R32
Stabilisation or Warm-up Time (EN) *1	0%v.v ±0.1%Vol in 60 seconds
Calibration Curve (EN) or Basic Error (AQ)	0 to 14%v.v of -> 0.06%v.v or ±6% of Reading whichever is greater.
Short Term Stability (EN) of the Displayed Value(AQ)	0%v.v = ±0.02%v.v 7%v.v = ±0.3%v.v
Minimum Resolution (AQ)	From 0 to 14%v.v -> ±0.002%v.v
Long Term Stability (EN) or Working Stability (AQ)	0%v.v = ±0.03%v.v / Month 7%v.v = ±0.2%v.v / Month
Temperature Error (with Compensation) (-40°C to +75°C, relative to 20°C)	0%v.v to 7%v.v = ±0.3%v.v 7%v.v to 14%v.v = ±0.5%v.v
Humidity Error (10%RH to 90%RH, relative to 45%RH)	0%v.v = ±0.05%v.v 7%v.v = ±0.3%v.v
Response Time *2 (without dust filter)	T ₉₀ ≤ 30 sec
Power Supply Variations (at ±5% of Nominal Voltage)	<i>The Performance of the INIR is not affected by power supply variations as long as the power supply provides DC Regulated voltage according to specifications.</i>
Power Supply Rejection Ration (PSRR) (at ±5% of Nominal Voltage)	at 1 MHz -> 50 dB , at 100 kHz -> 68 dB , at 10 kHz -> 88 dB
Temperature Cycling or Ramping Drift (Maximum at 1.3°C/min.)	0%v.v = ±0.05%v.v 7%v.v = ±0.2%v.v
Thermal Shock Drift	0%v.v = ±0.05%v.v (max)
Uncertainty Error of Calibration	±0.5% Error of the Actual Reading

*1 Wait for 45 mins for the Sensor to warm up and reach the Ambient Temperature after power on.

*2 NOTE: All data and tests are relating to EN 60079-29-1 and AQ 6211, European and Chinese standards. For more information about Average please read the Application Note 1, "Integrated IR Protocol & Calibration".