

Up to PL e of EN ISO 13849-1 PNOZ s5



Safety relay for monitoring E-STOP pushbuttons, safety gates and light beam devices

Approvals

	PNOZ s5
	◆
	◆
	◆

Unit features

- ▶ Positive-guided relay outputs:
 - 2 safety contacts (N/O), instantaneous
 - 2 safety contacts (N/O), delay-on de-energisation
- ▶ 1 semiconductor output
- ▶ Connection options for:
 - E-STOP pushbutton
 - Safety gate limit switch
 - Reset button
 - Light barriers
 - PSEN
- ▶ A connector can be used to connect 1 PNOZsigma contact expander module
- ▶ Delay-on de-energisation selectable
- ▶ Operating modes and delay times can be selected via rotary switches
- ▶ LED indicator for:
 - Supply voltage
 - Input status, channel 1
 - Input status, channel 2
 - Switch status channel 1/2
 - Reset circuit
 - Error
- ▶ Plug-in connection terminals (either spring-loaded terminal or screw terminal)

▶ See order reference for unit types

Unit description

The safety relay meets the requirements of EN 60947-5-1, EN 60204-1 and VDE 0113-1 and may be used in applications with

- ▶ E-STOP pushbuttons
- ▶ Safety gates
- ▶ Light beam devices

Safety features

The relay meets the following safety requirements:

- ▶ The circuit is redundant with built-in self-monitoring.
- ▶ The safety function remains effective in the case of a component failure.
- ▶ The correct opening and closing of the safety function relays is tested automatically in each on-off cycle.
- ▶ The unit has an electronic fuse.

Block diagram

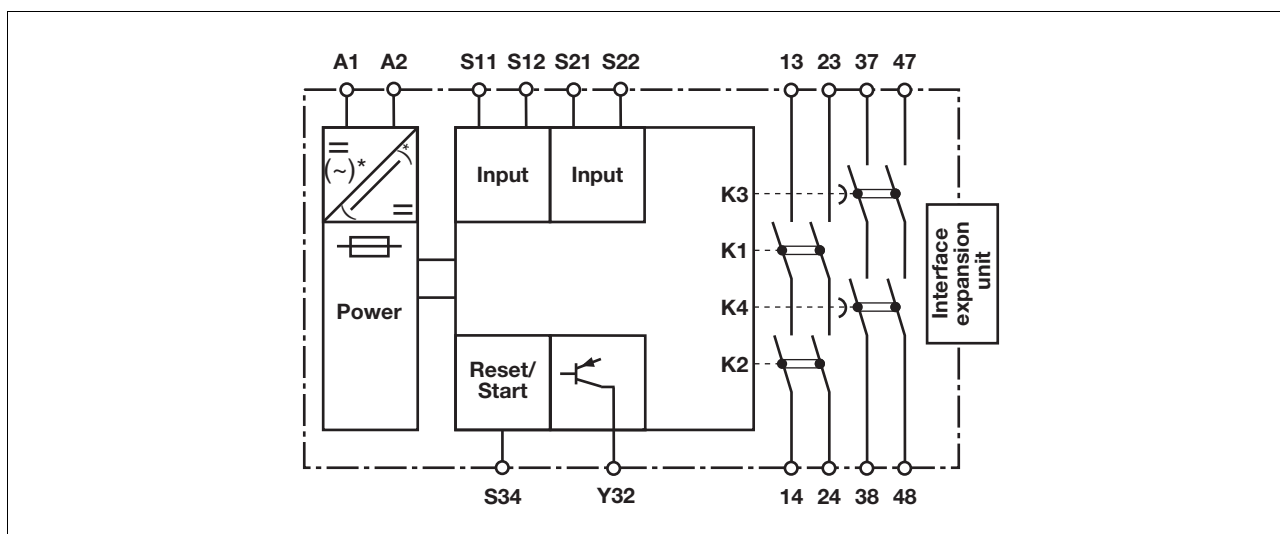

*only with $U_B = 48 - 240 \text{ V AC/DC}$

Up to PL e of EN ISO 13849-1 PNOZ s5

Function description

- ▶ Single-channel operation: no redundancy in the input circuit, earth faults in the reset and input circuit are detected.
- ▶ Dual-channel operation without detection of shorts across contacts: redundant input circuit, detects
 - earth faults in the reset and input circuit,
 - short circuits in the input circuit and, with a monitored reset, in the reset circuit too.
- ▶ Dual-channel operation with detection of shorts across contacts: redundant input circuit, detects
 - earth faults in the reset and input circuit,
 - short circuits in the input circuit and, with a monitored reset, in the reset circuit too,
 - shorts between contacts in the input circuit.
- ▶ Automatic start: Unit is active once the input circuit has been closed.
- ▶ Manual reset: Unit is active once the input circuit is closed and then the reset circuit is closed.
- ▶ Monitored reset with falling edge: Unit is active once
 - the input circuit is closed and then the reset circuit is closed and opened again.
 - the reset circuit is closed and then opened again once the input circuit is closed.
- ▶ Monitored reset with rising edge: Unit is active once the input circuit is closed and once the reset circuit is closed after the waiting period has elapsed (see technical details).
- ▶ Reset with start-up test: The unit checks whether safety gates that are closed are opened and then closed again when supply voltage is applied.
- ▶ Ability to increase the number of contacts available on the
 - instantaneous safety contacts by using connectors to link to a PNOZsigma contact expansion module
 - delayed/instantaneous safety contacts by connecting contact expansion modules or external contactors