

2. Specifications

Characteristic	Item		Specifications	
Contact	Arrangement		1 Form A	1 Form C
	Contact resistance (Initial)		Max. 100 mΩ (By voltage drop 6 V DC 1A)	
	Contact material		AgNi type, AgNi type/Au-plated	
Rating	Nominal switching capacity (resistive load)		6 A 250 V AC	
	Max. switching power (resistive load)		1,500 VA	
	Max. switching voltage		250V AC	
	Max. switching current		6 A (AC)	
	Nominal operating power		170 mW (5 to 24 V DC), 217 mW (48 V DC), 175 mW (60 V DC)	
	Min. switching capacity (Reference value)*1		100 mA 5 V DC (without Au-plated), 1 mA 1 V DC (with Au-plated)	
Electrical characteristics	Insulation resistance (Initial)		Min. 1,000MΩ (at 500V DC) Measurement at same location as "Breakdown voltage" section.	
	Breakdown voltage (Initial)	Between open contacts	1,000 Vrms for 1 min. (Detection current: 10 mA)	
		Between contact and coil	4,000 Vrms for 1 min. (Detection current: 10 mA)	
	Surge breakdown voltage*2 (Between contact and coil) (Initial)		6,000 V	
	Temperature rise (coil) (at 20°C 68°F)		Max. 45°C 113°F (By resistive method, nominal coil voltage applied to the coil; contact carrying current: 6A.)	
	Operate time (at 20°C 68°F)		Max. 8 ms (Nominal coil voltage applied to the coil, excluding contact bounce time.)	
	Release time (at 20°C 68°F)		Max. 4 ms (Nominal coil voltage applied to the coil, excluding contact bounce time.) (without diode)	
Mechanical characteristics	Shock resistance	Functional	Min. 98 m/s ² (Half-wave pulse of sine wave: 11 ms; detection time: 10μs)	Min. 49 m/s ² (Half-wave pulse of sine wave: 11 ms; detection time: 10μs)
		Destructive	Min. 980 m/s ² (Half-wave pulse of sine wave: 11 ms.)	
	Vibration resistance	Functional	10 to 55 Hz at double amplitude of 1 mm (Detection time: 10μs.)	
		Destructive	10 to 55 Hz at double amplitude of 1.5 mm	
Expected life	Mechanical		Min. 5×10 ⁶ (at 180 times/min.)	
	Electrical*4		N.O.: Min. 5×10 ⁴ (at resistive load, 6 times/min. and nominal switching capacity)	N.O.: Min. 5×10 ⁴ , N.C.: Min. 3×10 ⁴ (at resistive load, 6 times/min. and nominal switching capacity)
Conditions	Conditions for operation, transport and storage*3		Ambient temperature: -40°C to +85°C -40°F to +185°F; Humidity: 5 to 85% R.H. (Not freezing and condensing at low temperature)	
Unit weight			Approx. 5 g .18 oz	

Notes: *1. This value can change due to the switching frequency, environmental conditions, and desired reliability level, therefore it is recommended to check this with the actual load.

*2. Wave is standard shock voltage of ±1.2×50μs according to JEC-212-1981

*3. The upper operation ambient temperature limit is the maximum temperature that can satisfy the coil temperature rise value. Refer to "Usage, transport and storage conditions" in NOTES.

*4. For cycle lifetime, refer to "Cautions for use 4)" in NOTES.

REFERENCE DATA

1. Electrical life

Tested sample: APF30224

Load type		Voltage	Current	Ambient temperature	No. of ops.
Resistive load		250V AC	6 A	85°C 185°F	30,000
Inductive load	AC15	250V AC	3 A	25°C 77°F	20,000
	DC13	24V DC	2 A	25°C 77°F	6,000

Notes: 1. Switch contacts are all on N.O. side.

2. AC15 and DC13 comply with IEC-60947-5-1 testing conditions.

2. Max. switching capacity

Tested sample: APF30224

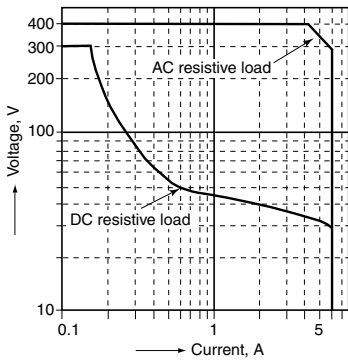

3. Coil temperature rise

Tested sample: APF30224

Measured portion: Inside the coil

Ambient temperature: 28°C 82°F

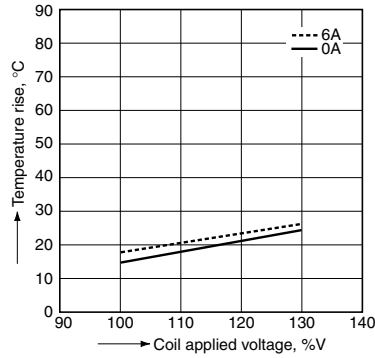

4. Ambient temperature characteristics

Tested sample: APF30224, 6 pcs.

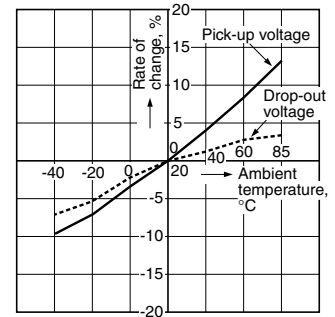

DIMENSIONS (mm inch)

The CAD data of the products with a **CAD Data** mark can be downloaded from: <http://industrial.panasonic.com/ac/e/>

1. 1 Form A type

CAD Data



External dimensions

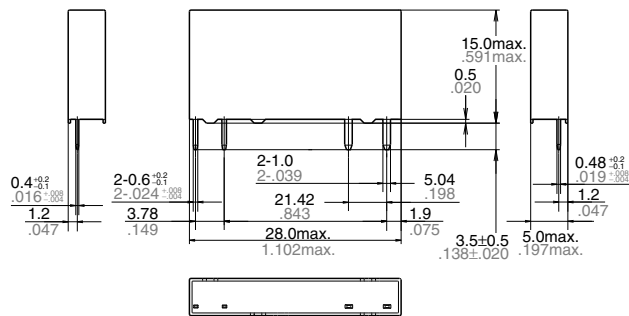

General tolerance: $\pm 0.3 \pm 0.012$

PC board pattern (Bottom view)

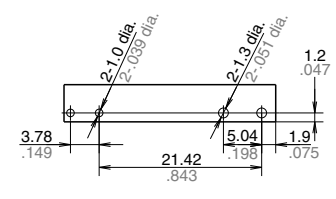

Tolerance: $\pm 0.1 \pm 0.004$

Schematic (Bottom view)

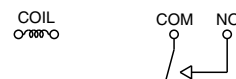

2. 1 Form C type

CAD Data



External dimensions

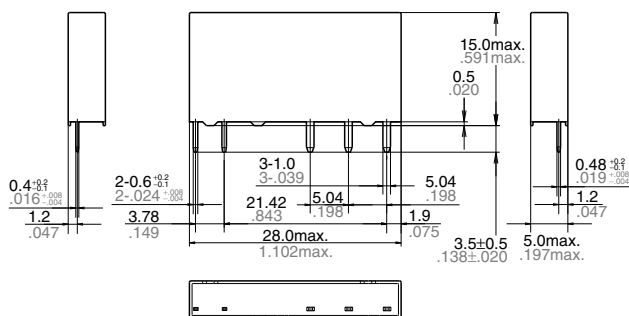

General tolerance: $\pm 0.3 \pm 0.012$

PC board pattern (Bottom view)

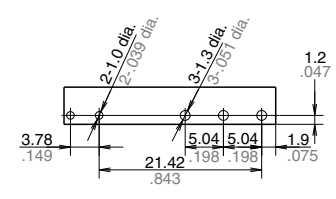

Tolerance: $\pm 0.1 \pm 0.004$

Schematic (Bottom view)

