

Microphotonic Devices (Light Convergent Reflective Sensor) B5W-LA01 STD

■ Dimensions

Note: All units are in millimeters unless otherwise indicated.

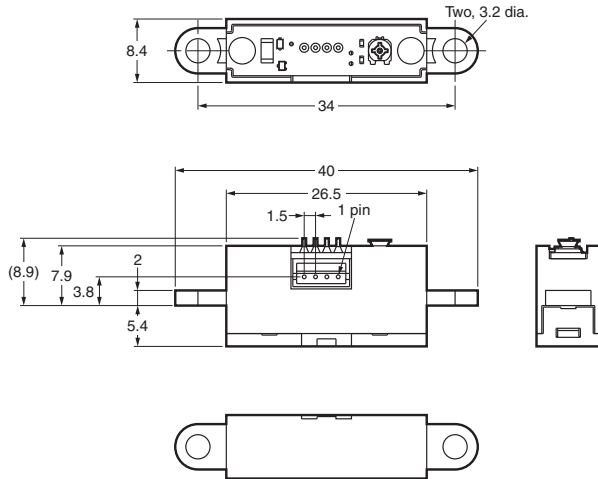

Circuit diagram

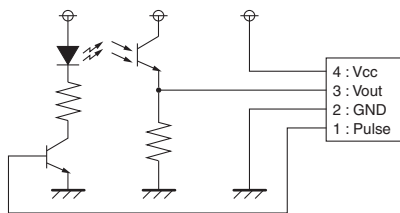

PIN number	Terminal name	Remarks
1	Pulse	Pulse input pin
2	GND	Ground pin
3	Vout	Output voltage pin
4	Vcc	Input voltage pin

Unless otherwise specified, the tolerances are ± 0.3 mm.

Connector type
: JST S4B-ZR
Number of pins
: 4 pin

■ Features

- Robust performance with little influence from sensing object color or material.
- Detects objects with mirror reflective surfaces and transparent objects.
- Analog voltage output.
- Maximum sensing distance of 70 mm.

■ Absolute Maximum Ratings (Ta = 25°C)

Parameter	Symbol	Ratings	Unit
Supply voltage	V _{CC}	5.5	V
Operating temperature	T _{opr}	-10 to +60	°C
Storage temperature	T _{stg}	-25 to +80	°C

■ Electrical and Optical Characteristics (Ta = 25°C)

Item	Symbol	Characteristics			Unit	Condition
		MIN.	TYP.	MAX.		
Operating supply voltage	V _{CC}	4.5	5.0	5.5	V	---
Maximum Output voltage	V _{omax}	---	3.3	---	V	---
Output voltage (Far)	V _{ofar}	---	---	30	mV	At L = 70 mm by White paper *
Output voltage (Near)	V _{onear}	70	---	---	mV	At L = 22.8 mm by Black paper *

* Input frequency; 500 Hz duty 40%, Input voltage; 5 V
 Output voltage at no reflective object is defined as 0 mV.
 The reference surface and mounting surface are shown in the following figure.

Measurement method of distance to reflective object

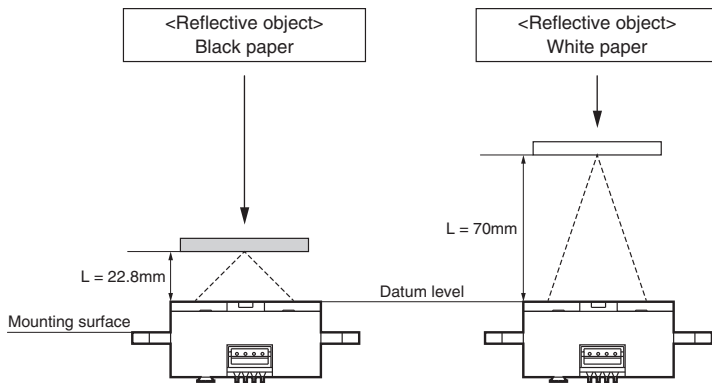

Engineering Data

Measurement data of distance characteristics for reference

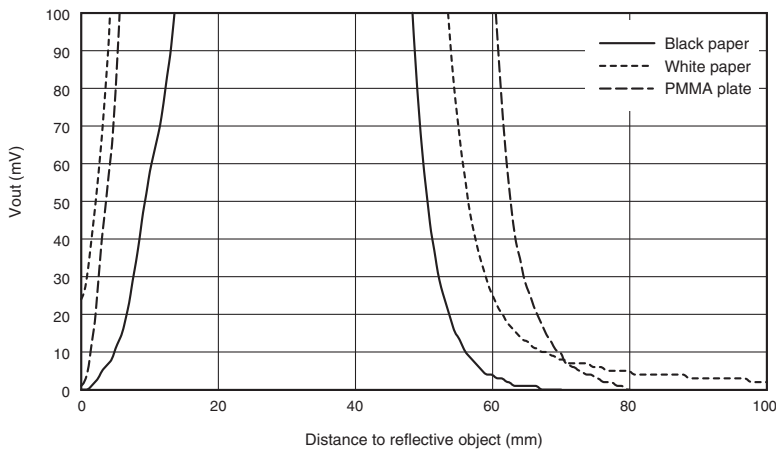

Recommend sampling timing

I/O Timing

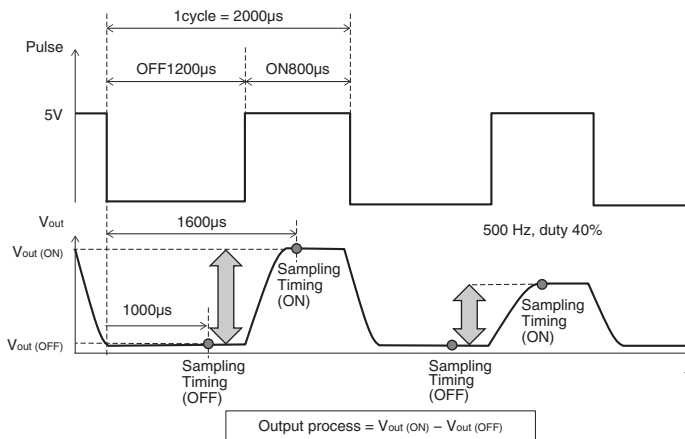

• Application examples provided in this document are for reference only. In actual applications, confirm equipment functions and safety before using the product.
 • Consult your OMRON representative before using the product under conditions which are not described in the manual or applying the product to nuclear control systems, railroad systems, aviation systems, vehicles, combustion systems, medical equipment, amusement machines, safety equipment, and other systems or equipment that may have a serious influence on lives and property if used improperly. Make sure that the ratings and performance characteristics of the product provide a margin of safety for the system or equipment, and be sure to provide the system or equipment with double safety mechanisms.

Note: Do not use this document to operate the Unit.