

Engineering Data (Reference value)

Dust concentration - Number of Detected Particles Correlation Graph

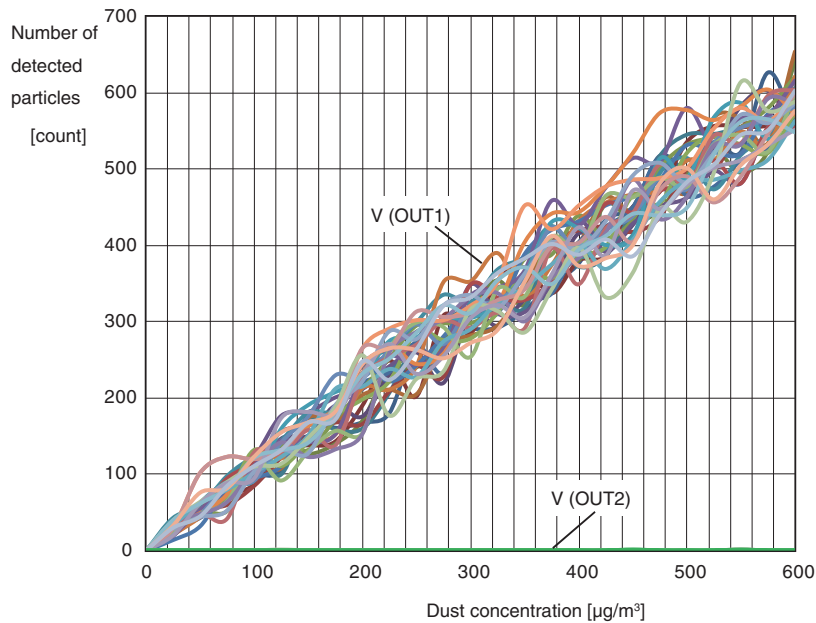

Measurement environment

Dust monitor Model: TSI DUSTTRAK II MODEL8530
 Impactor: 1.0 µm, Calibration factor=1
 Air Quality Sensor Threshold voltage: 0.5 V
 Measurement time: 20 sec

Detection object: Smoke of incense
 Conditions: Ta=25°C, Vcc=5 V, 0 Lx

Note: The above figure shows reference information from 30 pcs measurement.

Output Signals

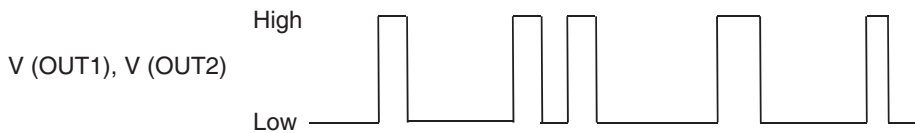

- A positive pulse of 0 V is output when particles are not detected and 5 V when particles are detected
- Count the number of pulses within the measurement time and take this number to be the sensor count.
- The minimum pulse width is 0.5 msec.
- Use a sampling frequency of 4 kHz or more.

Internal Block Diagram

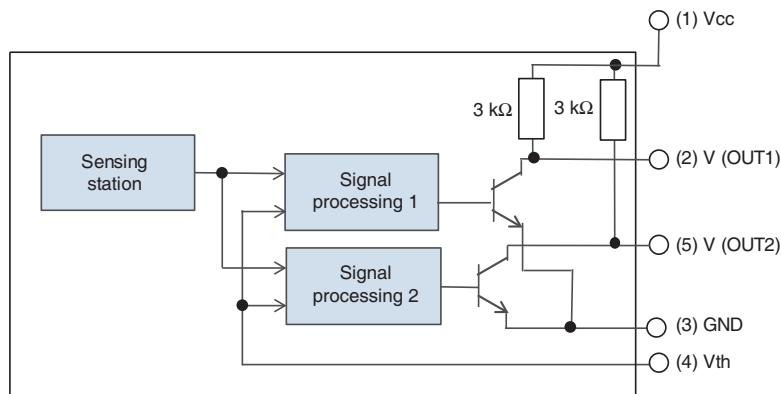

Safety Precautions

To ensure safe operation, be sure to read and follow the Instruction Manual provided with the Sensor.

CAUTION

This product is not designed or rated for ensuring safety of persons either directly or indirectly. Do not use it for such purposes.



Precautions for Safe Use

Do not use the product with a voltage or current that exceeds the rated range.

Applying a voltage or current that is higher than the rated range may result in explosion or fire.

Do not miswire such as the polarity of the power supply voltage.

Otherwise the product may be damaged or it may burn.

This product does not resist water. Do not use the product in places where water or oil may be sprayed onto the product.

When installing, arrange so that the heater portion cannot be accessed by the end user.

Precautions for Correct Use

Do not use the product in atmospheres or environments that exceed product ratings.

Treat this product as industrial waste when disposing.

Mounting posture: Use this product standing vertically (within $\pm 3^\circ$).

Install with the suction inlet facing downwards and the exhaust outlet facing upwards. Ensure that a space that is the same as that specified on the following page is secured in order to prevent the suction inlet and exhaust outlet from becoming clogged with dust.

So that the detection area will be completely dark, place a cap over the lens cleaning window.

Stable measurements can be performed approximately 1 minute after the power supply is turned on.

Remove any debris adhered to the lens using a dry cotton swab.

When installing, arrange so that the heater portion cannot be accessed by the end user.

Do not use organic solvents as they may alter lens properties.

Elements of this product may be damaged or its reliability may decrease due to surges in voltage caused by static electricity, etc. When handling, take measures to prevent static electricity, such as using wristbands or static electricity preventing gloves.

Never insert or remove connectors while the power supply is on.

Do not touch the pre-set resistors for adjusting sensor sensitivity.

Do not apply mechanical stress to this product. Doing so could result in damage to the product or defective sensor properties. Also, sufficiently confirm that no such defects have occurred when using while mounted to your products.

Be aware that injuries may occur if sharp portions such as the lead of the soldered surface or the edge of the circuit board are touched when handling this product.

When handling this product, take care to prevent the lens surface from being scratched or becoming dirty. Failure to do so may result in changes to sensor properties. Also, ensure that there is no freezing or condensation.

When inserting or removing connectors, do so in a level and perpendicular manner. Never insert or remove connectors by twisting vertically, horizontally, or in a slanted manner. When inserting connectors, ensure that they are fully inserted.

Do not use products that have been dropped. Doing so could result in damage to the product or defective sensor properties.

Only use after determining that usage is possible by sufficiently evaluating for the following changes in properties.

- (a) Temperature properties (if there are changes in ambient temperature when using this product, changes in output from that sensor)
- (b) Response properties (sensor output changes due to sampling timing when using this product)
- (c) Freezing/condensation conditions (if freezing or condensation occur when using this product, changes in output from that sensor)

Defects and damage caused by these changes in properties shall not be covered by warranty.