

# MP Motion Sensor (AMN1)

## 2) Analog output

Items		Symbol	Specified value	Measured conditions
Reted operating voltage	Minimum	Vdd	4.5 V DC	
	Maximum		5.5 V DC	
Reted consumption current	Typical	Iw	0.17 mA	Iout = 0
	Maximum		0.3 mA	
Output current	Maximum	Iout	50 $\mu$ A	
Output voltage	Minimum	Vout	0 V	
	Typical		2.5 V	
	Maximum		Vdd	
Output offset average voltage	Minimum	Voff	2.3 V	Steady-state output voltage when not detecting
	Typical		2.5 V	
	Maximum		2.7 V	
Steady-state noise	Typical	Vn	130 m Vp-p	
	Maximum		300 m Vp-p	
Circuit stability time	Typical	Twu	7 s	
	Maximum		45 s	

Note: To set to the same detection performance as the digital type, set the output voltage to the offset voltage (2.5V)  $\pm$ 0.45V (i.e. 2.95V or more and 2.05V or less).

### [Timing chart]

#### 1) Digital output

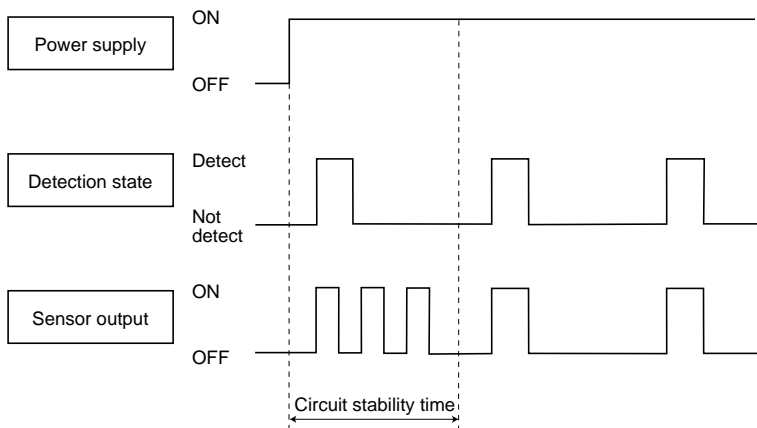

Remark: Circuit stability time: 45s max. (45s max. for the 10m detection type)

While the circuitry is stabilizing after the power is turned on, the sensor output is not fixed in the "on" state or "off" state. This is true regardless of whether or not the sensor has detected anything.

#### 2) Analog output

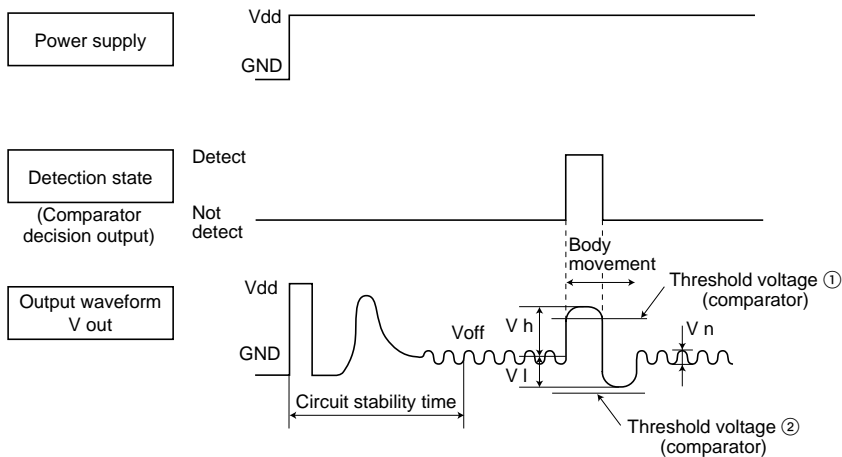

Remark: Circuit stability time: 30s max.

While the circuitry is stabilizing after the power is turned on, the sensor output is not fixed in the "on" state or "off" state. This is true regardless of whether or not the sensor has detected anything.

**DETECTION PERFORMANCE**

1. Standard detection type

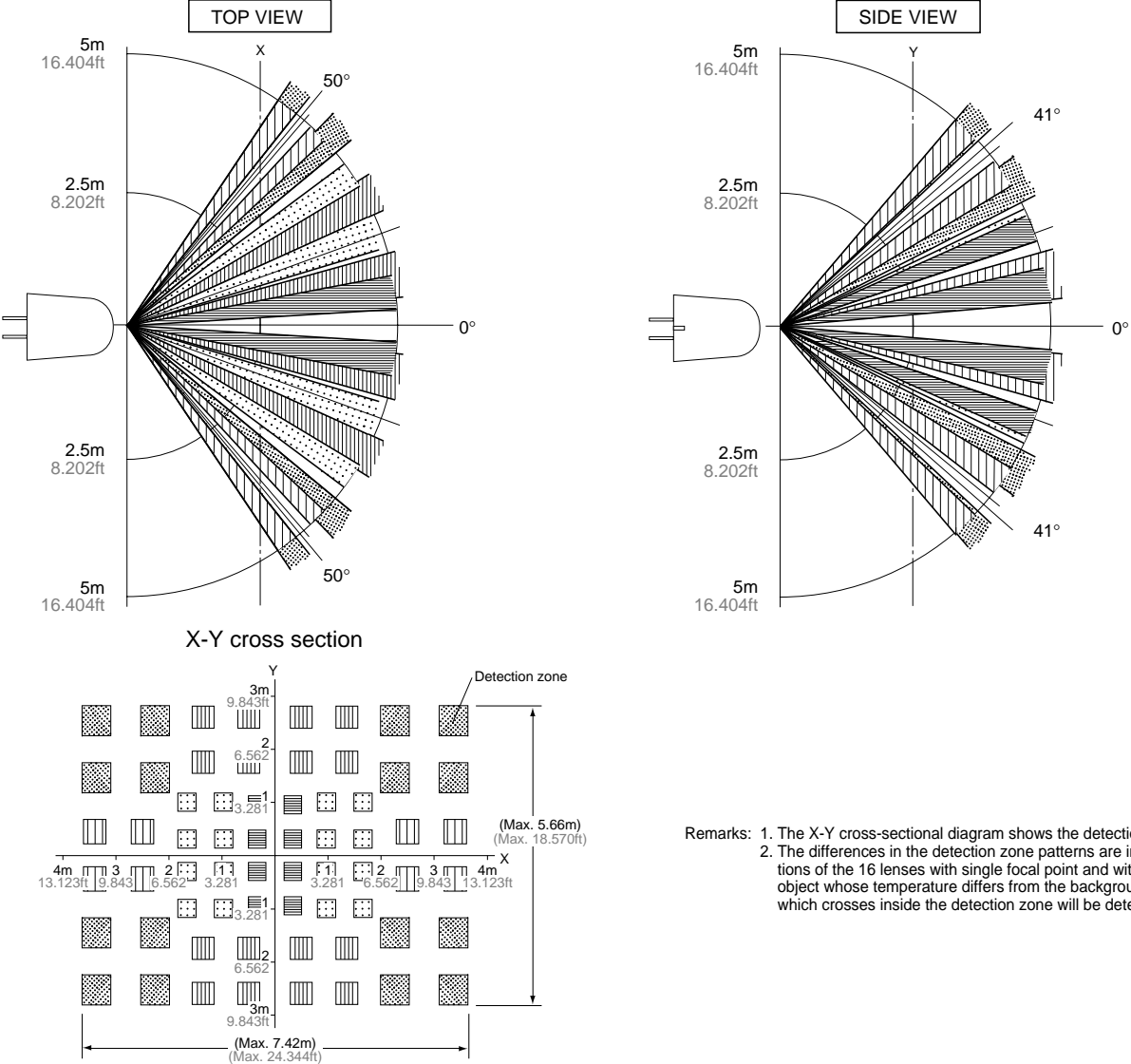

Remarks: 1. The X-Y cross-sectional diagram shows the detection area.  
 2. The differences in the detection zone patterns are indicative of the projections of the 16 lenses with single focal point and with five optical axes. An object whose temperature differs from the background temperature and which crosses inside the detection zone will be detected.

2. Slight motion detection type

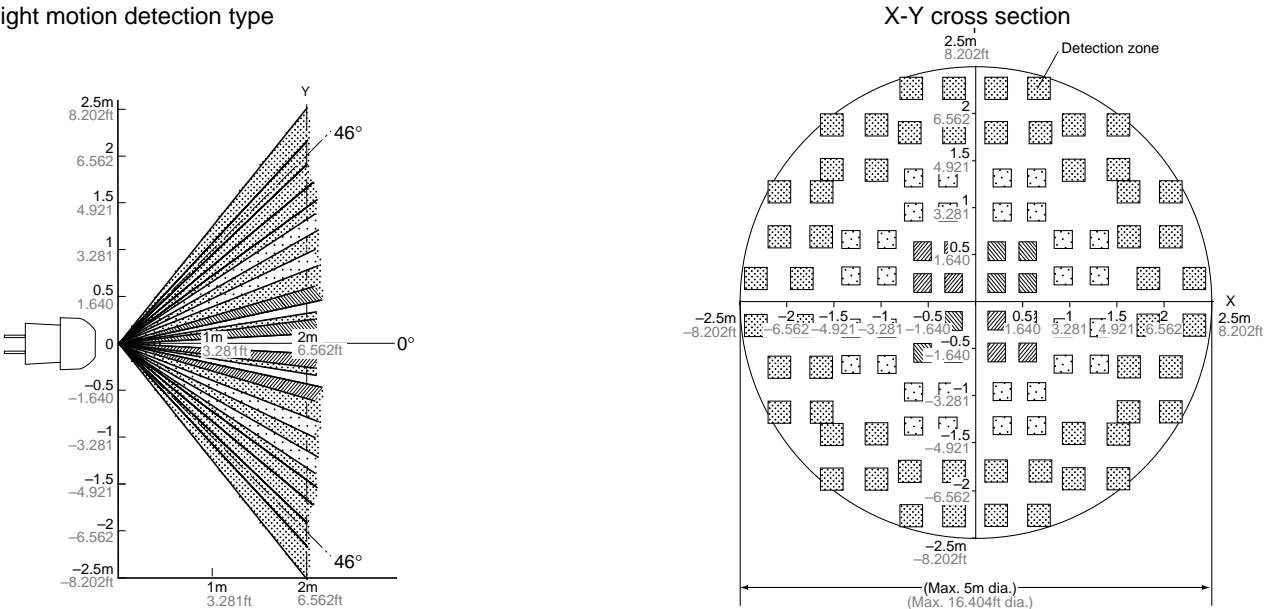

Remarks: 1. The X-Y cross-sectional diagram shows the detection area.  
 2. The differences in the detection zone patterns are indicative of the projections of the 26 lenses with single focal point and with three optical axes. An object whose temperature differs from the background temperature and which crosses inside the detection zone will be detected.