

### Terminal Block Relays



### Contents

#### Description

#### Terminal Block Relays

Standard Terminal Block Relays .....	<b>V7-T3-4</b>
OptoCoupler Terminal Block Relays .....	<b>V7-T3-12</b>
High Current Terminal Block Relays .....	<b>V7-T3-15</b>
<b>XR Series Accessories</b> .....	<b>V7-T3-18</b>

### Catalog Number Selection

#### XR Series—Overview

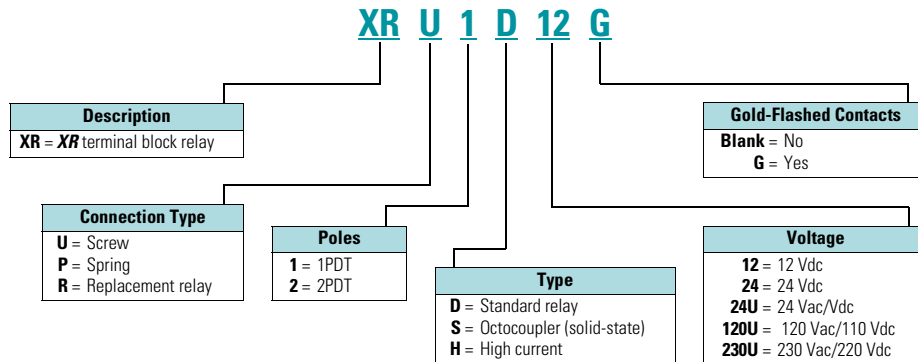

Standard Terminal Block Relay



### Contents

<i>Description</i>	<i>Page</i>
Standard Terminal Block Relays	
Product Selection . . . . .	<b>V7-T3-5</b>
Technical Data and Specifications . . . . .	<b>V7-T3-6</b>
Electrical Schematics . . . . .	<b>V7-T3-11</b>
Dimensions . . . . .	<b>V7-T3-11</b>
OptoCoupler Terminal Block Relays . . . . .	<b>V7-T3-12</b>
High Current Terminal Block Relays . . . . .	<b>V7-T3-15</b>
<b>XR</b> Series Accessories . . . . .	<b>V7-T3-18</b>

### Standard Terminal Block Relays

#### Product Description

The **XR** Series Terminal Block Relays are ideal for applications that require a high switching capacity and long electrical service life. The relays are plug-in interfaces that connect to basic terminal blocks. The **XR** Series uses screw or spring-cage technology, as well as offers quick system wiring, superior safety features, clear labeling and a high level of modularity.

#### Application Description

Used in automation systems, electromechanical relays guarantee a safe connection between process I/O and electronic controls. The following functions are covered by relay coupling elements:

- Electrical isolation between the input and output circuits
- Independence of the type of switching current (AC and DC)
- High short-term overload resistance in the event of short circuits or voltage peaks
- Low switching losses
- Ease of operation

#### Features

- Pluggable relay allows for field replacement
- Functional plug-in bridges
- Choice of screw connections or spring-cage connection
- LED status indication
- DIN rail mount
- Only 6.2 mm wide for single-pole versions, 14 mm wide for double-pole
- All common input voltages between 12 Vdc to 120 Vac

- Gold-plated contacts available
- Equipped with a robust, miniature relay:
  - IP67 protection
  - Environmentally friendly, cadmium-free contact material
  - Easy, cost-effective installation and replacement using the engagement lever

#### Standards and Certifications

- cULus listed
- CE

