



FEATURES

- Small
- Low Noise
- Robust: High Over-Range
- High Reliability
- mV Output: 20mV/V Nominal
- Low Deflection
- Fast
- Essentially Unlimited Cycle Life

APPLICATIONS

- Assembly Forces
- Physical Therapy Devices
- Patient Weight
- Hand Tool Forces
- Chiropractic and Exercise Equipment
- Consumables Monitoring: Copy Equipment and Vending systems
- Appliance Payload Monitoring: Washers, Dryers, Water Weight, Extraction Efficiency
- Appliance Unbalance Monitoring

FX1901

Compression Load Cell

SPECIFICATIONS

- **High Reliability Design for OEM, Appliance and Medical Applications**
- **10 – 200 lbf Ranges**
- **Compact Coin Cell Package**
- **Anti-Rotation Mounting Features**
- **CE Compliance**

The **FX1901** units are intended for OEM use in laboratory, hospital or consumer product applications, establishing a breakthrough price/performance value for compression load cells. The FX1901 is a 1% load cell device with full scale ranges of 10, 25, 50 or 100 and 200lbf compression. This new, low-cost technology enables force sensing in a whole new class of "smart" consumer and medical products.

MEAS' proprietary Microfused™ technology, derived from demanding aerospace applications, employs micro-machined piezoresistive strain gages fused with high temperature glass to a high performance stainless steel force measuring flexure. Microfused™ technology eliminates age-sensitive organic epoxies used in traditional load cell designs, providing excellent long term span and zero stability. Operating at very low strains, Microfused™ technology provides an essentially unlimited cycle life expectancy, superior resolution, high over-range capabilities and a ratiometric span of 20mV/V. The combination of stamped flexures and micro miniaturized MEMS strain gages permits low costs to be achieved in high volume OEM applications ranging from disposable medical devices to durable appliances and exercise equipment.

STANDARD RANGES

Range	lbf
0 to 0010	•
0 to 0025	•
0 to 0050	•
0 to 0100	•
0 to 0200	•

PERFORMANCE SPECIFICATIONS

Supply Voltage: 5.0V, Ambient Temperature: 25°C (unless otherwise specified)

PARAMETERS	MIN	TYP	MAX	UNITS	NOTES
Recommended Excitation		5		V	
Full Scale Output Span	16	20	24	mV/V	
Full Scale Output Span (200lbf)	34.2	36	37.8		
Zero Offset	-15		15	mV/V	
Non-Linearity	-1		1	%FSO	
Hysteresis	-0.80		0.80	%Span	
Thermal Zero Shift	-0.05		0.05	%FSO / °C	
Thermal Sensitivity Shift	-0.05		0.05	%FSO / °C	
Insulation Resistance	50			MΩ	@500Vdc
Maximum Overload		250		%FSO	
Maximum Overload (200lbf)		150		%FSO	
Operating Temperature	0		50	°C	
Storage Temperature	-40		+85	°C	
Creeping			0.5	%FSO	F.S. Span in 3min
Zero Drift			0.5	%FSO	Load F.S. 3min
Zero Return	-0.8		0.8	%FSO	
Span Repeat	-0.8		0.8	%FSO	
Humidity	0	5	90	%R.H.	
Deflection		0.05		mm	At Rated Load
Span Compensation Resistor (10, 25, 50 100lbf)		464		Ω	
Input Resistance	2.4	3	3.6	KΩ	
Output Resistance	1.76	2.2	2.64	KΩ	

For custom configurations, consult factory.

CE Compliance

IEC61000-4-2 [4 kV/ 4 kV (Air/Contact)]

IEC61000-4-3 (3 V/m)

IEC55022 Class A

FX1901

Compression Load Cell

DIMENSIONS

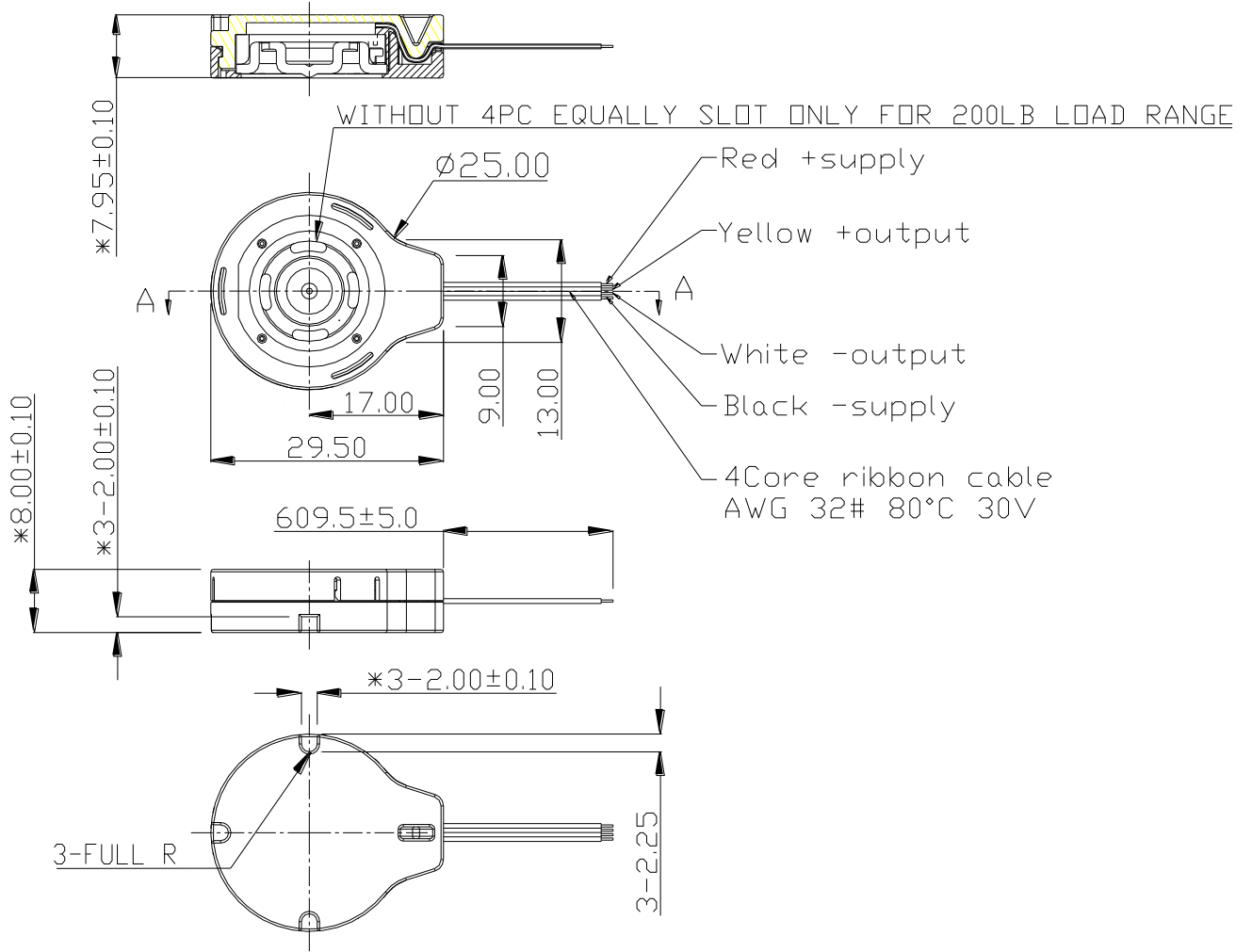

WIRING INFORMATION

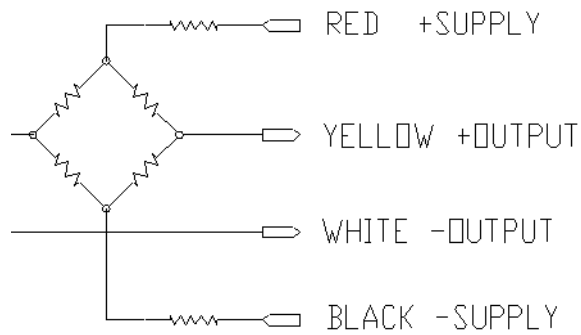

ORDERING INFORMATION

FX19	0	1	-	0001	-	0250	L
Model	Output	Connection	-	Specials	-	Force Range	Units
FX19	0 = 20mV	1 = 2ft Cable	-	0001	-	0010 0025 0050 0100 0200	L = lbf

NORTH AMERICA

Measurement Specialties, Inc.,
a TE Connectivity company
45738 Northport Loop West
Fremont, CA 94538
Tel: +1 800 767 1888
Fax: +1 510 498 1578
customercare.frmt@te.com

EUROPE

MEAS France SAS,
a TE Connectivity company
26 Rue des Dames
78340 Les Clayes-sous-Bois, France
Tel: +33 (0) 130 79 33 00
Fax: +33 (0) 134 81 03 59
customercare.lcsb@te.com

ASIA

Measurement Specialties (China) Ltd.,
a TE Connectivity company
No. 26 Langshan Road
Shenzhen High-Tech Park (North) Nanshan District,
Shenzhen, 518057
China
Tel: +86 755 3330 5088
Fax: +86 755 3330 5099
customercare.shzn@te.com

TE.com/sensorsolutions

Measurement Specialties, Inc., a TE Connectivity company.

Measurement Specialties, TE Connectivity, TE Connectivity (logo) and EVERY CONNECTION COUNTS are trademarks. All other logos, products and/or company names referred to herein might be trademarks of their respective owners.

The information given herein, including drawings, illustrations and schematics which are intended for illustration purposes only, is believed to be reliable. However, TE Connectivity makes no warranties as to its accuracy or completeness and disclaims any liability in connection with its use. TE Connectivity's obligations shall only be as set forth in TE Connectivity's Standard Terms and Conditions of Sale for this product and in no case will TE Connectivity be liable for any incidental, indirect or consequential damages arising out of the sale, resale, use or misuse of the product. Users of TE Connectivity products should make their own evaluation to determine the suitability of each such product for the specific application.

© 2015 TE Connectivity Ltd. family of companies All Rights Reserved.