

Electrical Specification

Conforming to Standards BS/EN60947

DC CURRENT:	S10 25A nominal current flows through L1, L2, M1 & M2 Smooth-BRAKE 60 Amp or 90 Amp high current connections directly to thyristor diode module.
FREQUENCY:	The unit is for rated 50 Hz.
DWELL TIME:	From operating main contactor to closing DC contactor: S10 0.5 seconds Smooth-BRAKE 1 second
TIME RANGE:	S10 braking time range is 0.1 to 12.7 seconds (270° rotation linear potentiometer) Smooth-BRAKE 0.2 to 50 seconds (270° rotation linear potentiometer)
DC VOLTAGE:	The voltage range is up to approx. 160 volts, with the minimum voltage dependent on thyristor latching current.
DUTY CYCLE:	S10 Limited by software to 10%. For every second of braking 10 is added to a register. For every second not braking 1 is subtracted. Restart is inhibited if the register is above a value of 250. Note: if the unit will not start it will be waiting for this register to count down below 250. The maximum delay is approx. 2 minutes. Smooth-BRAKE No software limitation of duty cycle. Heat sink rated for 10 off equally spaced 35 second stops per hour maximum at stated current.
DIMENSIONS:	S10 81H x 45W x 121D (mm) - DIN Rail mounting Smooth-BRAKE 100H x 160W x 125D (mm)
TERMINALS:	S10 2 times 2.5mm ² max Smooth-BRAKE main terminals M5 screw control terminals 2 times 2.5mm ² max
WEIGHT:	S10 200g Smooth-BRAKE 1.0kg
HUMIDITY:	85% non condensing
AMBIENT TEMP:	Operating -10 to +40C Storage -20 to +70C
PROTECTION:	IP code IP20
RELAYS: RL1	Internal 8A rated contacts, 440Vac max breaking voltage.
RL2	The relay terminals 17 18 28 are volt free and can be wired in a control circuit at lower voltage. The relay contacts can be protected with a 4 Amp Control fuse.
BRAKE FUSE:	Semiconductor fuse S10 30A (10mm x 38mm) FL078 740 A ² sec Ferraz 660gRB10-30 A070gRB30T13 ref M330015 or equivalent. Diode 40EPS12 800 A ² sec Thyristor 40TPS12 1250 A ² sec Smooth-BRAKE 60 Amp SKNH56 or IRKN56 8000 A ² sec FE100 semiconductor fuse 1800A ² sec NSD 32 3000 A ² sec approx 60A 100 sec trip point NSD 40 6000 A ² sec approx 100A 100 sec trip point 90 Amp SKNH91 or IRKN91 15000 A ² sec FE120 semiconductor fuse 1900A ² sec ESD 50 8700 A ² sec approx 120A 100 sec trip point ESD 63 13300 A ² sec approx 150A 100 sec trip point

S10 Module Terminals Identification and marking

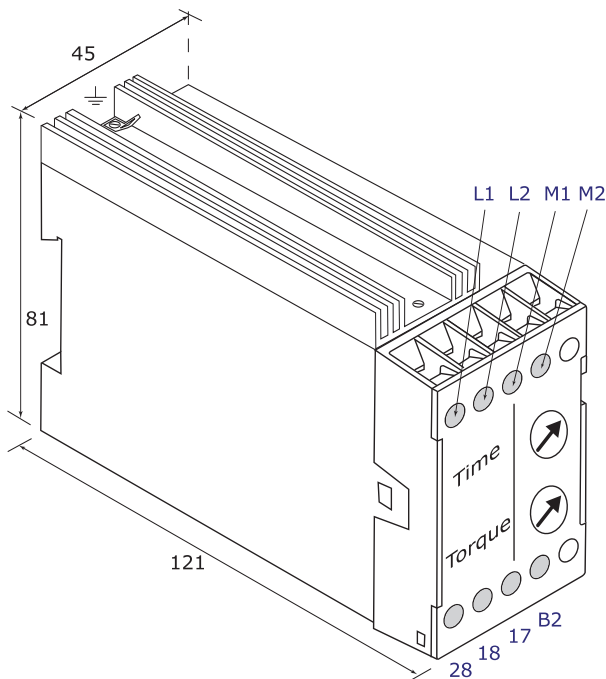

Part Numbers

BR011 400v

BR016 240v

BR021 110v

- L1** Common phase connection
- L2** Phase connection - connected to **M2**
- M1** Motor connection
- M2** Motor connection - connected directly to **L2**
- B2** Voltage sense input
- 17** Relay input - common to RL1 and RL2
- 18** RL1 Relay output - motor contactor via stop start circuit
- 28** RL2 Relay output connects to brake contactor

The **B2** terminal to signal the unit to brake requires the full operating voltage of the module applied.

L1 is common internally so a normally open auxiliary contact on the main contactor is used to provide a signal on **B2** from **L2**.