

SPECIFICATION	CONNECTION	DELTA
NO. OF POL./PHASE		8/3
VOLTAGE RATED (VDC)		48
CURRENT NO LOAD/RATED/PEAK (AMP)		0.4/4.63/13.89
RESISTANCE/PHASE TO PHASE (Ohms) @25°C		0.58±15%
INDUCTANCE/PHASE TO PHASE (mH) @1KHz		1.21±20%
TORQUE RATED/PEAK (Nm) [lb-in]		0.25/0.75 [2.213/6.638]
TORQUE/VOLTAGE CONSTANT (Nm/A)/(Vrms/KRPM)		0.054/4.4=BACK EMF
POWER RATED/PEAK (W)		160/650
SPEED RATED/NO LOAD (U/min)		6000/8500
ROTOR INERTIA (Kg-m <sup>2</sup> ) [lb-in <sup>2</sup> ]		9.6x10 <sup>-6</sup> [3.28x10 <sup>-2</sup> ]
WEIGHT (Kg) [lb]		0.75 [1.654]
TEMPERATURE RISE: MAX.80°C		
AMBIENT TEMPERATURE -10°~ 50°C [14°F ~ 122°F]		
INSULATION RESISTANCE 100 MOhm (UNDER NORMAL TEMPERATURE AND HUMIDITY)		
INSULATION CLASS B 130° [266°F]		
DIELECTRIC STRENGTH 500VAC FOR 1 MIN. (BETWEEN THE MOTOR COILS AND THE MOTOR CASE)		
AMBIENT HUMIDITY MAX. 85% (NO CONDENSATION)		

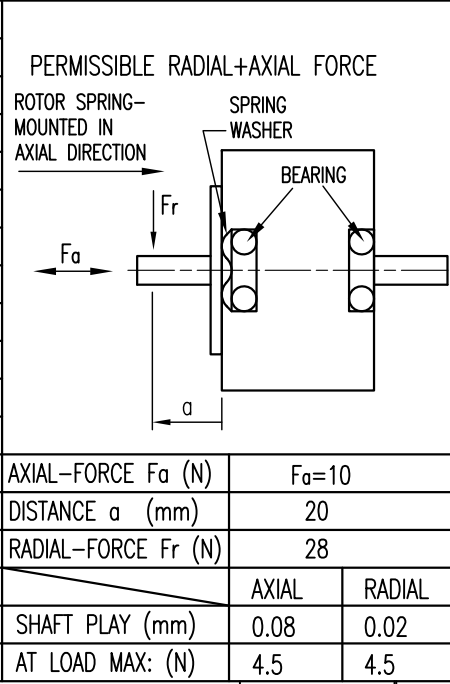

TWINTUS CONNECTOR M12 12 POLE	
PIN NO.	ENC./HALL
1	GND
2	5 V
3	GND
4	A
5	A\
6	B
7	B\
8	I
9	I\
10	H1
11	H2
12	H3

TWINTUS CONNECTOR M16 3 POLE	
PIN NO.	FUNCTION
1	U
2	V
3	W

WIRING DIAGRAMM						
FUNCTION	Dir. ← →					
U	X	HI	HI	X	LOW	LOW
V	HI	X	LOW	LOW	X	HI
W	LOW	LOW	X	HI	HI	X
+5V						
H1	0	0	0	1	1	1
H2	0	1	1	1	0	0
H3	1	1	0	0	0	1
GND						

3	LENGTH CHANGED	07.03.12	J.W.
2	PIN NO. 3 SUPPLEMENTED	02.01.12	J.W.
1	PIN ASSIGNMENT CHANGED	08.12.11	J.W.
REV	DESCRIPTION	DATE	APVD

**Nanotec**  
PLUG & DRIVE

ASB42C048060-ENM

SCALE FREE	APVD	S.H.	28.07.11
X ±0.5	CHKD		
1PL ±0.2	DRN	J.W.	28.07.11
2PL ±0.1	SIGNATURE	DATE	
ANGLE ±30°			

**DC MOTOR IN PROTECTION**

DWG.NO ASB42C048060-ENM