

## **VPR100 VRX100 VRX150**

## **User Manual**

57-77-25-15

Rev. 4

12/00

---

# Copyright, Notices, and Trademarks

Printed in U.S.A. – © Copyright 2000 by Honeywell

Revision 4 – 12/00

## WARRANTY/REMEDY

Honeywell warrants goods of its manufacture as being free of defective materials and faulty workmanship. Contact your local sales office for warranty information. If warranted goods are returned to Honeywell during the period of coverage, Honeywell will repair or replace without charge those items it finds defective. The foregoing is Buyer's sole remedy and is in lieu of all other warranties, expressed or implied, including those of merchantability and fitness for a particular purpose. Specifications may change without notice. The information we supply is believed to be accurate and reliable as of this printing. However, we assume no responsibility for its use.

While we provide application assistance personally, through our literature and the Honeywell web site, it is up to the customer to determine the suitability of the product in the application.

**Sensing and Control**  
Honeywell  
11 West Spring Street  
Freeport, Illinois 61032

---

# About This Document

## Abstract

This manual describes the installation, configuration, operation, and maintenance of the VPR100 Video Programmer Recorder, the VRX100 Video Recorder, and the VRX150 Video Recorder.

## Contacts

### World Wide Web

The following lists Honeywell's World Wide Web sites that will be of interest to our customers.

Honeywell Organization	WWW Address (URL)
Corporate	<a href="http://www.honeywell.com">http://www.honeywell.com</a>
Sensing and Control	<a href="http://www.honeywell.com/sensing">http://www.honeywell.com/sensing</a>
International	<a href="http://www.honeywell.com/Business/global.asp">http://www.honeywell.com/Business/global.asp</a>













### Telephone

Contact us by telephone at the numbers listed below.

	Organization	Phone Number
United States and Canada	Honeywell	1-800-423-9883 Tech. Support
		1-888-423-9883 Q&A Faxback (TACFACS)
		1-800-525-7439 Service
Asia Pacific	Honeywell Asia Pacific Hong Kong	(852) 2829-8298
Europe	Honeywell PACE, Brussels, Belgium	[32-2] 728-2111
Latin America	Honeywell, Sunrise, Florida U.S.A.	(854) 845-2600

## Symbol Definitions

The following table lists those symbols that may be used in this document to denote certain conditions.

Symbol	Definition
	This <b>DANGER</b> symbol indicates an imminently hazardous situation, which, if not avoided, <b>will result in death or serious injury</b> .
	This <b>WARNING</b> symbol indicates a potentially hazardous situation, which, if not avoided, <b>could result in death or serious injury</b> .
	This <b>CAUTION</b> symbol may be present on Control Product instrumentation and literature. If present on a product, the user must consult the appropriate part of the accompanying product literature for more information.
	This <b>CAUTION</b> symbol indicates a potentially hazardous situation, which, if not avoided, <b>may result in property damage</b> .
	<b>WARNING</b> <b>PERSONAL INJURY:</b> Risk of electrical shock. This symbol warns the user of a potential shock hazard where HAZARDOUS LIVE voltages greater than 30 Vrms, 42.4 Vpeak, or 60 Vdc may be accessible. <b>Failure to comply with these instructions could result in death or serious injury.</b>
	ATTENTION, Electrostatic Discharge (ESD) hazards. Observe precautions for handling electrostatic sensitive devices
	Protective Earth (PE) terminal. Provided for connection of the protective earth (green or green/yellow) supply system conductor.
	Functional earth terminal. Used for non-safety purposes such as noise immunity improvement. NOTE: This connection shall be bonded to protective earth at the source of supply in accordance with national local electrical code requirements.
	Earth Ground. Functional earth connection. NOTE: This connection shall be bonded to Protective earth at the source of supply in accordance with national and local electrical code requirements.
	Chassis Ground. Identifies a connection to the chassis or frame of the equipment shall be bonded to Protective Earth at the source of supply in accordance with national and local electrical code requirements.
	Earth Ground. Functional earth connection. NOTE: This connection shall be bonded to Protective earth at the source of supply in accordance with national and local electrical code requirements.
	Chassis Ground. Identifies a connection to the chassis or frame of the equipment shall be bonded to Protective Earth at the source of supply in accordance with national and local electrical code requirements.

---

### **CE conformity**

This product conforms with the protection requirements of the following European Council Directives: 89/336/EEC, the EMC directive, and 73/23/EEC, the low voltage directive. Do not assume this product conforms with any other “CE Mark” Directive(s).

### **Attention**

The emission limits of EN 50081-2 are designed to provide reasonable protection against harmful interference when this equipment is operated in an industrial environment. Operation of this equipment in a residential area may cause harmful interference. This equipment generates, uses, and can radiate radio frequency energy and may cause interference to radio and television reception when the equipment is used closer than 30 meters to the antenna(e). In special cases, when highly susceptible apparatus is used in close proximity, the user may have to employ additional mitigating measures to further reduce the electromagnetic emissions of this equipment.

---

# Contents

<b>1. INTRODUCTION .....</b>	<b>1</b>
1.1 Three manuals in one.....	1
1.2 VPR100 Overview.....	1
1.3 VRX100 Overview.....	2
1.4 VRX150 Overview.....	3
1.5 Unpacking.....	4
1.6 Specifications .....	5
1.7 Model Number.....	13
<b>2. INSTALLATION.....</b>	<b>15</b>
2.1 Installing optional DSU software .....	15
2.2 Site Preparation .....	15
2.3 Location.....	16
2.4 Mounting .....	16
2.5 Wiring.....	20
<b>3. PROGRAMMING AND OPERATING CONCEPTS AND PROCEDURES .....</b>	<b>31</b>
3.1 Overview .....	31
3.2 Quick Start Programming .....	31
3.3 Modes of Operation.....	31
3.4 Menu Navigation .....	32
3.5 Button functions .....	39
3.6 Text Entry From External Sources .....	44
3.7 Access to Floppy Drive, Keyboard/Barcode Reader Connection .....	46
3.8 Definition of Function Blocks .....	48
3.9 Components of function blocks.....	50
3.10 How to program input parameters .....	54
3.11 How to program function block parameters .....	57
3.12 How to program a simple configuration.....	57
3.13 How to program common configurations.....	59
3.14 Data Storage .....	73
<b>4. HOW TO PROGRAM FUNCTION BLOCKS AND FEATURES .....</b>	<b>77</b>
4.1 Overview .....	77
4.2 Programming tips.....	78
4.3 The Program mode menu.....	79
4.4 Frequently used programming prompts.....	80
4.5 Set Mode.....	81

---

4.6	Enter Labels .....	82
4.7	Program Analog Inputs .....	85
4.8	Program Control Loops.....	89
4.9	Program Analog Outputs.....	100
4.10	Program Discrete Inputs.....	104
4.11	Program Discrete Outputs.....	105
4.12	Program Calculated Values.....	106
4.13	Program Alarms .....	144
4.14	Program Totalizers.....	146
4.15	Program Profiles .....	148
4.16	Program Constants .....	149
4.17	Copy Block.....	151
4.18	Program Displays.....	152
4.19	Enable Features .....	163
4.20	Program Security.....	164
4.21	Serial Communications .....	165
4.22	Set Clock.....	166
4.23	Load/Store Config.....	167
4.24	Scan Rate.....	168
4.25	Select Language .....	169
4.26	Data Storage.....	170
<b>5.</b>	<b>SETPOINT PROFILER .....</b>	<b>183</b>
5.1	Overview of the Setpoint Profiler.....	183
5.2	Components of a profile.....	186
5.3	Parameters that control a profile's execution .....	194
5.4	How to set up a profiler .....	200
5.5	How to load and run a profiler.....	208
<b>6.</b>	<b>ONLINE OPERATIONS USING PRIMARY DISPLAYS.....</b>	<b>219</b>
6.1	Overview.....	219
6.2	Interacting With Primary Displays .....	221
6.3	Display Messages and Symbols.....	229
<b>7.</b>	<b>ONLINE OPERATION USING MENUS .....</b>	<b>233</b>
7.1	Overview.....	233
7.2	Set Mode .....	234
7.3	Data Storage.....	234
7.4	Access Summaries .....	240
7.5	Data Entry .....	244
7.6	Setpoint Profiles.....	246
7.7	Tune Loop.....	247
7.8	Review Programming.....	254

---

<b>8.</b>	<b>MAINTENANCE.....</b>	<b>255</b>
8.1	Overview .....	255
8.2	Routine Maintenance.....	257
8.3	Set Mode.....	257
8.4	Calibrate Analog Inputs.....	257
8.5	Calibrate Analog Outputs .....	258
8.6	Off-line Diagnostics .....	259
8.7	Database Services.....	260
8.8	Reset Unit .....	260
8.9	Product Information.....	260
8.10	Mains Frequency .....	260
8.11	Warm Start Time .....	261
8.12	Demo .....	262
<b>9.</b>	<b>ON-SITE ADJUSTMENTS .....</b>	<b>263</b>
9.1	Removing the Circuit Card Assembly.....	263
9.2	Changing Analog Input Ranges.....	266
9.3	Changing the CAT/VAT Setting.....	267
9.4	Changing number of DIs/DOs .....	268
9.5	Setting The Communications Link Termination Jumper .....	270
9.6	Diagnostic Messages .....	271
9.7	Loop Error Indicators .....	275
<b>10.</b>	<b>ERROR MESSAGES.....</b>	<b>277</b>
<b>11.</b>	<b>PARTS.....</b>	<b>281</b>
<b>APPENDIX A.....</b>		<b>291</b>
A.1	Security Bypass Procedure .....	291
<b>APPENDIX B HOW TO APPLY DIGITAL INSTRUMENTATION IN SEVERE ELECTRICAL NOISE ENVIRONMENTS.....</b>		<b>293</b>
B.1	Overview .....	293
B.2	Potential Noise Sources.....	294
B.3	Prevention Methods.....	295
B.4	Recommended Wiring Practices .....	296
B.5	Power Source Considerations.....	298
B.6	Noise Suppression at the Source .....	299
B.7	Ferrite Clamp Installation Procedure.....	303

**MULTILANGUAGE SAFETY INSTRUCTIONS**



# Tables

Table 1-1	Specifications .....	5
Table 1-2	Analog Input Accuracy--Linear types.....	10
Table 1-3	Analog Input Accuracy--Non-linear types.....	11
Table 1-4	Standards .....	12
Table 2-1	Panel Mounting Procedure .....	16
Table 2-2	Screw Lengths for Panel Thicknesses.....	16
Table 2-3	Terminal Designators And Their Associated Applications .....	20
Table 2-4	Optional Cards for Terminal Board TB3.....	21
Table 2-5	Optional Cards for Terminal Boards TB3A & TB3B .....	22
Table 2-6	Optional 12 PT AI Card Terminal Boards TB3A & TB3B.....	23
Table 2-7	Recommended Minimum Wire Size.....	24
Table 2-8	Communications Connections .....	29
Table 2-9	Communications Wiring Procedure.....	29
Table 3-1	Button Functions .....	39
Table 3-2	QWERTY Key Equivalents.....	44
Table 3-3	Front Bezel Open/Close Procedure .....	46
Table 3-4	Function Block Types.....	49
Table 3-5	Function Block Parameter Designators .....	52
Table 3-6	Output Code Connection Procedure .....	54
Table 3-7	Example Number Selection Procedure Using Front Panel Buttons .....	56
Table 3-8	Example Programming Discrete Input Parameter with a Number.....	56
Table 3-9	Example Function Block Parameter Selection Procedure .....	57
Table 3-10	Function Block Configuration Procedure .....	57
Table 3-11	Example Configuration Procedure .....	58
Table 3-12	Data Storage File Extensions.....	74
Table 3-13	Configuration and Calibration Filename Extensions .....	76
Table 4-1	Program Mode Menu.....	79
Table 4-2	Frequently Used Programming Prompts.....	80
Table 4-3	Labels for Function Blocks.....	83
Table 4-4	Other Labels .....	84
Table 4-5	Analog Input Algorithm Selection.....	85
Table 4-6	Standard Algorithm Prompts .....	85
Table 4-7	Custom Algorithm Prompts .....	88
Table 4-8	Loop Characteristics.....	89
Table 4-9	Control Loop Type Menu Selections.....	91
Table 4-10	Loop Prompts .....	93
Table 4-11	Analog Output Types.....	100
Table 4-12	Prompts For Analog Output Types.....	100
Table 4-13	Analog Output Prompts .....	101
Table 4-14	Discrete Input Prompts.....	104
Table 4-15	Discrete Output Prompts .....	105
Table 4-16	CV Types.....	106
Table 4-17	Peak Picking Prompts.....	107
Table 4-18	Signal Select Prompts.....	108
Table 4-19	Compare Prompts .....	109
Table 4-20	Compare's Condition Type and Condition Time Prompts .....	111
Table 4-21	Counter Prompts.....	113
Table 4-22	Math Prompts .....	114
Table 4-23	Free Form Math Prompts.....	115
Table 4-24	Free Form Math Functions .....	116
Table 4-25	Logic Prompts .....	117
Table 4-26	Logic Operators.....	118

---

Table 4-27	Free Form Logic Prompts .....	119
Table 4-28	(A OR B) AND C .....	120
Table 4-29	Results of Logic Equation Using Iteration .....	120
Table 4-30	Inverter Prompts .....	121
Table 4-31	BCD Prompts.....	122
Table 4-32	How Profiles Are Saved In Memory (VPR only) .....	123
Table 4-33	Function Generator Prompts.....	124
Table 4-34	Interval Timer Prompts.....	126
Table 4-35	Periodic Timer Prompts.....	128
Table 4-36	Set Up Timer Prompts .....	128
Table 4-37	Mass Flow Prompts .....	129
Table 4-38	Carbon Prompts .....	130
Table 4-39	Relative Humidity Prompts.....	132
Table 4-40	F <sub>0</sub> Sterilization Prompts .....	133
Table 4-41	Advanced Splitter Prompts .....	135
Table 4-42	Standard Splitter Prompts .....	136
Table 4-43	Scaling Prompts.....	137
Table 4-44	Signal Clamp Prompts .....	138
Table 4-45	1 Point Block Average Prompts .....	139
Table 4-46	Rolling Average Prompts.....	140
Table 4-47	Multiple Average Prompts.....	141
Table 4-48	CEMS Block Average Prompts .....	142
Table 4-49	CEMS Rolling Average Prompts.....	143
Table 4-50	Alarm Prompts.....	144
Table 4-51	Totalizer Prompts .....	147
Table 4-52	Constant Prompts.....	149
Table 4-53	Copy Block Prompts.....	151
Table 4-54	Display Setup Procedure .....	155
Table 4-55	Set Up Trend 1 Prompts .....	155
Table 4-56	Paper Chart Speed Equivalents to Time Base Selections .....	157
Table 4-57	VRX 100 Live Trend Buffer Size.....	157
Table 4-58	VRX 150 Live Trend Buffer Size.....	158
Table 4-59	Set Up Bar Graph 1 Prompts .....	159
Table 4-60	Set Up Panel Display Prompts.....	159
Table 4-61	Set Up Unit Data Display Prompts .....	159
Table 4-62	Set Up Profile Display Prompts.....	160
Table 4-63	Assign Displays To Keys Prompts.....	161
Table 4-64	Enable Features Prompts .....	163
Table 4-65	Security Prompts.....	164
Table 4-66	Serial Communications Prompts.....	165
Table 4-67	Set Clock Prompts .....	166
Table 4-68	Access Config Files Prompts.....	167
Table 4-69	Suggested Scan Rates .....	168
Table 4-70	Data Storage Setup Procedure .....	170
Table 4-71	Prompts For Storage Setup Of Trends, Alarms, Events, Diagnostics .....	172
Table 4-72	Stored Events.....	174
Table 4-73	Unit Data Prompts .....	175
Table 4-74	Storage Allocation Prompts.....	177
Table 4-75	Capacity of 1.44 Megabyte Floppy Disk .....	178
Table 4-76	Capacity of 120 Megabyte Disk .....	179
Table 4-77	120MB/Zip Preinitialization Procedure.....	180
Table 4-78	Filename Extensions Of Data Storage Types.....	181
Table 5-1	Example of Segment Events .....	192
Table 5-2	Parameters That Control Profiler Execution.....	195

Table 5-3	Program Profiler Prompts.....	201
Table 5-4	Setpoint Profiles Prompts.....	202
Table 5-5	Edit Profile Prompts.....	204
Table 5-6	Edit Segments Prompts.....	207
Table 5-7	How Profiles Are Stored In Memory (VPR100/VRX150 only).....	209
Table 5-8	Procedure To Load A Program From Memory Using Online Menu (VPR100/VRX150 only).....	210
Table 5-9	Procedure To Load A Program From Memory Using Any Profiler Display (VPR100/VRX150).....	210
Table 5-10	How Profiles Are Stored On Disk.....	211
Table 5-11	Disk Program Capacity.....	211
Table 5-12	Procedure To Load A Program From Disk.....	212
Table 5-13	Profiler Starting Procedure.....	213
Table 5-14	Profiler Hold Procedure.....	214
Table 5-15	Profiler Reset Procedure.....	214
Table 5-16	Profiler Advance Procedure.....	215
Table 5-17	Profiler Shutdown Procedure.....	215
Table 5-18	Event Viewing Procedure.....	216
Table 5-19	Details Viewing Procedure.....	216
Table 5-20	Summary Viewing Procedure.....	217
Table 5-21	Segment Editing Procedure.....	218
Table 6-1	Displays Accessed With Display Button.....	219
Table 6-2	Point/Detail Menu Prompts.....	223
Table 6-3	Stop Panel Display Rotation Procedure.....	225
Table 6-4	Resume Panel Display Rotation Procedure.....	225
Table 6-5	Stop 4-Panel Display Rotation Procedure.....	226
Table 6-6	Resume 4-Panel Display Rotation Procedure.....	226
Table 6-7	Interacting With Loop Displays.....	227
Table 6-8	Messages and Symbols at Bottom of Display.....	230
Table 6-9	Messages and Symbols Elsewhere on Display.....	231
Table 7-1	Online Mode Menu.....	233
Table 7-2	Floppy Disk Insertion/Removal Procedure.....	234
Table 7-3	Disk Status.....	235
Table 7-4	Storage Start/Stop Controls.....	237
Table 7-5	Data Storage Replay Procedure.....	239
Table 7-6	Alarm Acknowledgment Procedure.....	241
Table 7-7	Diagnostic Acknowledgment Procedure.....	242
Table 7-8	Delete All Diagnostics Procedure.....	243
Table 7-9	Tune Loop Prompts.....	247
Table 7-10	Stages Of Pretune.....	250
Table 7-11	Pretune STOPPED Prompts.....	250
Table 7-12	Pretune IDENTIFYING & CALCULATING Prompts.....	251
Table 7-13	Pretune COMPLETE Prompts.....	252
Table 7-14	Pretune Abort Messages.....	253
Table 8-1	Maintenance Mode Menu.....	255
Table 8-2	Calibrate EMF Input Procedure.....	257
Table 8-3	Calibrate RTD Input Procedure.....	258
Table 8-4	Calibrate Analog Output Procedure.....	259
Table 8-5	Offline Diagnostic Prompts.....	259
Table 8-6	Database Services Prompts.....	260
Table 9-1	Circuit Card Removal Procedure (VPR100 & VRX100).....	263
Table 9-2	Circuit Card Replacement Procedure (VPR100 & VRX100).....	264
Table 9-3	Circuit Card Removal Procedure (VRX150).....	265
Table 9-4	Circuit Card Replacement Procedure (VRX150).....	265
Table 9-5	Settings for expanded AI ranges.....	266
Table 9-6	S1 DIP Switch Default Settings.....	267
Table 9-7	DIP Switch Settings For DI/DO Combinations.....	269

---

Table 9-8 Diagnostic Error Messages .....	271
Table 9-9 Internal Error Messages .....	273
Table 9-10 Abnormal Loop Conditions And Indicators.....	275
Table 10-1 Error Messages .....	277
Table 11-1 Parts.....	281
Table Appendix A-1 Security Bypass Procedure.....	291
Table Appendix B-1 External Wiring .....	297
Table Appendix B-2 MOV Devices.....	299
Table Appendix B-3 Coil Voltage vs. Resistor Voltage Rating .....	300

---

# Figures

Figure 1-1	VPR100.....	1
Figure 1-2	VRX100 with Control .....	2
Figure 1-3	VRX100 without Control .....	2
Figure 1-4	VRX 150 Video Recorder .....	3
Figure 1-5	VPR Model Number.....	13
Figure 1-6	VRX100/VRX150 Model Number .....	14
Figure 2-1	VPR100 & VRX100 Mounting.....	18
Figure 2-2	VRX150 Mounting.....	19
Figure 2-3	Terminal Connections (TB3).....	21
Figure 2-4	Terminal Connections (TB3A & TB3B).....	22
Figure 2-5	Terminal Connections (TB3A & TB3B).....	23
Figure 2-6	Analog Input Wiring Connections.....	25
Figure 2-7	CAT or VAT Wiring Connection.....	26
Figure 2-8	Discrete Input Connections on TB3 .....	26
Figure 2-9	Discrete Input Connections on TB3A & TB3B.....	26
Figure 2-10	Discrete Output Connections.....	27
Figure 2-11	Position Proportional Typical Wiring .....	28
Figure 2-12	DIAT Typical Wiring.....	28
Figure 2-13	Network Data Cable Connections .....	30
Figure 3-1	VPR100's Front Bezel Buttons .....	32
Figure 3-2	VRX100's Front Bezel Buttons (With Control).....	32
Figure 3-3	VRX100's Front Bezel Buttons (Without Control).....	32
Figure 3-4	VRX150 Front Bezel Buttons .....	33
Figure 3-5	Menu Navigation Guide Through ON LINE, PROGRAM, and MAINTENANCE mode MAIN MENUs.....	35
Figure 3-6	ON LINE mode MAIN MENU.....	36
Figure 3-7	PROGRAM mode MAIN MENU .....	37
Figure 3-8	MAINTENANCE mode MAIN MENU.....	38
Figure 3-9	Access to Connector and Floppy Drive (VPR100 & VRX100) .....	46
Figure 3-10	Access To Connector and Floppy Drive (VRX150).....	47
Figure 3-11	Alarm 1 Function Block Components .....	50
Figure 3-12	Example Input Parameter Connection.....	54
Figure 3-13	Function Block Connection Format .....	55
Figure 3-14	Example Configuration .....	58
Figure 3-15	Control Of Furnace Zone Temperature With 4-20 mA (CAT) Control Signal.....	59
Figure 3-16	Basic Function Blocks Required For Control Configuration Of Figure 3-15.....	60
Figure 3-17	Labeling Each Function Block's Name And Major Inputs And Outputs .....	61
Figure 3-18	Labels For Internal Function Block Parameters .....	62
Figure 3-19	Interconnections Between Function Blocks .....	62
Figure 3-20	Complete Function Block Diagram Of Figure 3-15 .....	63
Figure 3-21	Control Of Wastewater pH Using A Time Proportioning (DAT) Control Signal .....	64
Figure 3-22	Function Block Diagram Of Figure 3-21.....	64
Figure 3-23	Temperature Control Of Water Using Split Output Or Duplex Control.....	65
Figure 3-24	Function Block Diagram Of Figure 3-23.....	66
Figure 3-25	Temperature Control Of An Oil Heated Chemical Reaction Chamber .....	67
Figure 3-26	Function Block Diagram Of The Cascade Control Strategy.....	68
Figure 3-27	Example Set Point Profile .....	69
Figure 3-28	Function Block Diagram Of Set Point Profile Control Of Figure 3-20 .....	70
Figure 3-29	Discrete Inputs Controlling Execution Of Set Point Profiler Function Block .....	70
Figure 3-30	Up To 16 Discrete Events May Be Programmed Per Step Of A Set Point Profile.....	71
Figure 3-31	Tying A Profile Function Block's Discrete Events With Discrete Output Hardware.....	72
Figure 3-32	Categories of Stored Data .....	73

Figure 4-1	Function Block Configuration of a Typical Ratio Control Loop.....	99
Figure 4-2	Function Block Configuration of a Position Proportional Function Block for One Position Proportional Control Loop.....	103
Figure 4-3	Compare Signal Flow.....	109
Figure 4-4	Compare's Greater Than Result, With Hysteresis.....	110
Figure 4-5	Math CV Feedback Programming.....	114
Figure 4-6	Logic Signal Flow.....	117
Figure 4-7	Free Form Logic Signal Flow.....	119
Figure 4-8	Function Generator Curve.....	124
Figure 4-9	Function Generator Configuration For Valve Characterization.....	125
Figure 4-10	Function Generator Configuration For Input Signal Characterization.....	125
Figure 4-11	Interval Timer.....	126
Figure 4-12	Periodic Timer.....	127
Figure 4-13	Typical Carbon Potential Control Configuration.....	131
Figure 4-14	Advanced Splitter (Default Outputs).....	134
Figure 4-15	Heat/Cool Configuration.....	134
Figure 4-16	Standard Split Output Function.....	136
Figure 4-17	CEMS Rolling Average.....	143
Figure 4-18	Example of Constant Destination.....	150
Figure 4-19	Displays Accessible by the Display Buttons.....	152
Figure 4-20	VRX150 Displays Accessible By The Display Button.....	154
Figure 5-1	Setpoint Profiler Schematic.....	184
Figure 5-2	Single and Multi-Phase Profiles.....	185
Figure 5-3	Value/Duration Ramp Type.....	187
Figure 5-4	Time Ramp Type.....	188
Figure 5-5	Rate Ramp Type.....	189
Figure 5-6	External Ramp Type.....	190
Figure 5-7	Guaranteed Soak and Hysteresis.....	191
Figure 5-8	Activating Events In Mid-Segment.....	192
Figure 5-9	Example Of A Segment Loop.....	193
Figure 5-10	Holding multiple profilers simultaneously.....	194
Figure 5-11	Hot Start.....	197
Figure 5-12	Fast Forward.....	198
Figure 5-13	Shutdown.....	199
Figure 5-14	Allowable and Non-Allowable Program Storage.....	203
Figure 5-15	VPR Buttons.....	208
Figure 6-1	Setpoint Profile Summary Displays.....	221
Figure 6-2	Setpoint Trend Display With Menu.....	221
Figure 6-3	Horizontal and Vertical Trend Displays.....	222
Figure 6-4	Vertical Trend at 2X Zoom.....	224
Figure 6-5	Panel Display.....	225
Figure 6-6	Four-Panel Display.....	226
Figure 6-7	Loop Displays.....	227
Figure 6-8	Alarm Summary Display.....	228
Figure 6-9	Example of Primary Display.....	229
Figure 7-1	Data Storage Status Display.....	238
Figure 7-2	Control Loop Tuning Display.....	249
Figure 8-1	RTD Calibration Connection.....	258
Figure 9-1	Circuit Card Removal (VPR100 & VRX100).....	264
Figure 9-2	Circuit Card Removal (VRX150).....	265
Figure 9-3	Locations Of AO DIP Switch S1.....	267
Figure 9-4	Location Of DIP Switch S1 On Discrete I/O Card.....	268
Figure 9-5	Instrument's Rear Terminals.....	268
Figure 9-6	Location of Jumpers W2 and W3.....	270

---

Figure 11-1	Panel Mounting Hardware Of Instrument .....	283
Figure 11-2	Card cage removed from case along with sub-bezel (3) and seal gasket (5) .....	283
Figure 11-3	Components of portable case .....	284
Figure 11-4	Exploded view of VPR/VRX100 display .....	285
Figure 11-5	Exploded View of VRX150 Display .....	286
Figure 11-6	Exploded view of instrument card cage.....	287
Figure 11-7	Components of case rear in units with 3 DI/4 DO or 6 DO point capability .....	288
Figure 11-8	Components of case rear in units with 12 AI or 16/32 DI/DO point capability .....	288
Figure 11-9	Module for Two Additional Analog Inputs .....	289
Figure Appendix B-1	Transformer for Digital Equipment.....	298
Figure Appendix B-2	Transient Suppression in Inductive Coils.....	300
Figure Appendix B-3	Contact Noise Suppression .....	301
Figure Appendix B-4	DC Load Noise Suppression .....	302
Figure Appendix B-5	Ferrite Clamp Installation .....	303

---



# 1. Introduction

## 1.1 Three manuals in one

This manual describes the VPR100 Video Programmer Recorder, the VRX100 Video Recorder, and the VRX150 Video Recorder. All instruments are alike with a few exceptions. These exceptions are noted throughout the manual. *Unless indicated otherwise, any feature described herein applies to all three instruments.*

## 1.2 VPR100 Overview

The Honeywell VPR100 Video Programmer Recorder (Figure 1-1) is part of the family of multi-point, multi-function video products. The instrument can process, display, and record analog and discrete data that is controlled by one or more control loops, each of which can each run its own setpoint profile.

The instrument features a high resolution LCD 139.7 mm (5.5") display capable of displaying up to 16 different colors simultaneously. The front panel is hinged to allow access to a 1.44MB or optional 120MB or Zip disk drive and a connector for a QWERTY keyboard or barcode reader for easy labeling of parameters.

Twelve panel keys control all functions of the instrument, including configuration.

The instrument will accept thermocouple, RTD, pyrometer, milliamp, millivolt and volt inputs. Up to eight analog outputs are available for retransmission or control, of which up to **four** are current adjusting or voltage adjusting. Data can be directed to various display formats, stored on disk, or read from an optional serial communications link. Analog and discrete data can be displayed in trend or tabular format. Viewed data can be either "live" (real time inputs) or historical (retrieved from disk).

Flexible modular design and several options makes this instrument adaptable to nearly any industrial application.

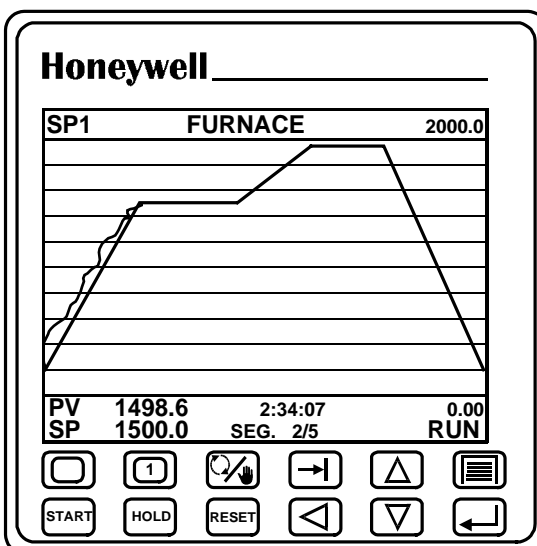


Figure 1-1 VPR100

### 1.3 VRX100 Overview

The Honeywell VRX100 Video Recorder (Figure 1-2 and Figure 1-3) is a multipoint video recorder that does more than just process data recording. It offers display versatility, flexible data storage, dual loop control and advanced math functions. This integration of several functions within the same instrument eliminates the need for multiple devices and reduces installation costs.

The instrument features a high resolution LCD 139.7 mm (5.5") display capable of displaying up to 16 different colors simultaneously. The front panel is hinged to allow access to a 1.44MB or optional 120MB or Zip disk drive and a connector for a QWERTY keyboard or barcode reader for easy labeling of parameters.

Twelve panel keys control all functions of the instrument, including configuration.

The instrument will accept thermocouple, RTD, pyrometer, milliamp, millivolt and volt inputs. Up to eight analog outputs are available for retransmission or control, of which up to **four** are current adjusting or voltage adjusting. Data can be directed to various display formats, stored on disk, or read from an optional serial communications link. Analog and discrete data can be displayed in trend or tabular format. Viewed data can be either "live" (real time inputs) or historical (retrieved from disk).

Flexible modular design and several options makes this instrument adaptable to nearly any industrial application.

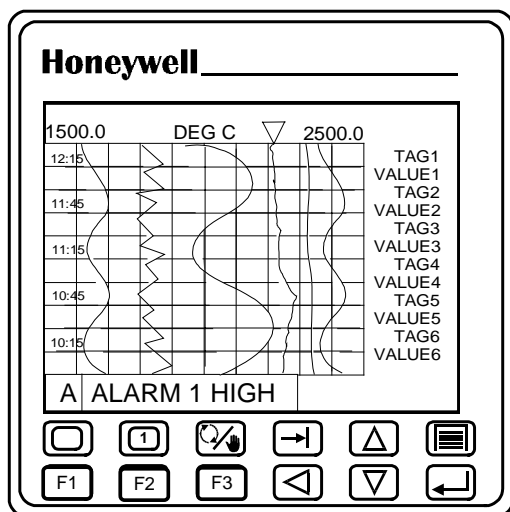


Figure 1-2 VRX100 with Control

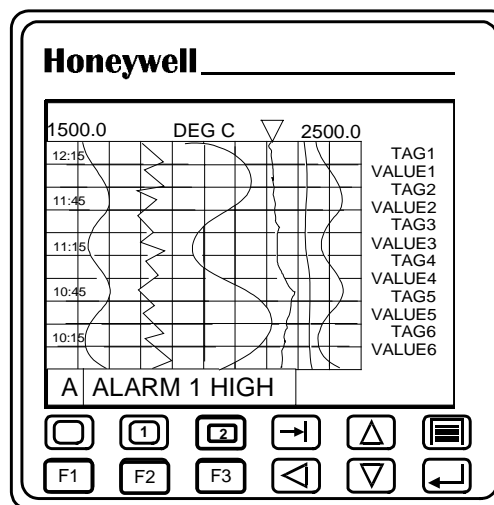


Figure 1-3 VRX100 without Control

## 1.4 VRX150 Overview

The Honeywell VRX150 Video Recorder is a multipoint video recorder that does more than just data recording. It offers display versatility, flexible data storage, multiloop control and advanced math functions. This integration of several functions within the same instrument eliminates the need for multiple devices and reduces installation costs.

The instrument features a large 10.4" (26.4 cm) diagonal high resolution LCD display which is capable of displaying up to 16 different colors simultaneously. A front door allows access to a 1.44MB or optional 120MB or Zip disk drive. A sliding front door allows access to a connector for a QWERTY keyboard or barcode reader for easy labeling of parameters.

Twelve panel keys control all functions of the instrument, including configuration.

The instrument will accept thermocouple, RTD, pyrometer, milliamp, millivolt and volt inputs. Up to eight analog outputs are available for retransmission or control, of which up to **four** are current adjusting or voltage adjusting. Data can be directed to various display formats, stored on disk, or read from an optional serial communications link. Analog and discrete data can be displayed in trend or tabular format. Viewed data can be either "live" (real time inputs) or historical (retrieved from disk).

Flexible modular design and several options make this instrument adaptable to nearly any industrial application.

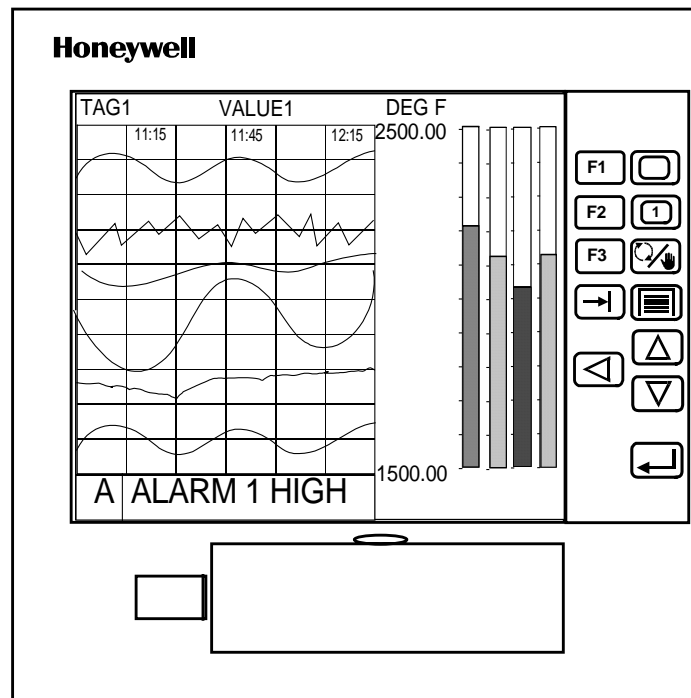


Figure 1-4 VRX 150 Video Recorder

## 1.5 Unpacking

Examine the shipping container carefully. If there are visible signs of damage, notify the carrier and Honeywell immediately.

If there is no visible damage, compare the contents with the packing list. Notify Honeywell if there is equipment shortage.

To obtain proper credit and to avoid delays, return goods only after contacting Honeywell in advance.

Carefully remove the instrument and remove any shipping ties or packing material. Follow the instructions on any attached tags or labels and then remove such tags or labels.

### **DSU floppy disk**

If you ordered the optional 120MB or Zip disk drive look for the floppy disk labeled “DSU – DATA STORAGE UTILITY”. See Section 2 for installation instructions.

## 1.6 Specifications

Specifications are the same for the VPR100, VRX100, and VRX150 unless noted otherwise.

**Table 1-1 Specifications**

Physical	
Enclosure	<p><u>VPR100 &amp; VRX100</u>            Drawn aluminum case with high impact resistant polycarbonate plastic bezel and abrasion/scratch resistant lens. With the proper panel mounting with the required gasketing and with the front bezel firmly close, the VPR100 and VRX100 meet the criteria for NEMA Type 3 Enclosure for protection from rain and sleet as described in NEMA Standard 250-1991 Sec. 6.4.2.2.</p> <p><u>VRX150</u>            Drawn aluminum case with high impact resistant polycarbonate plastic bezel.</p>
Mounting (Panel)	1.52 mm to 19.05 mm (0.06" to 0.75") thickness
Dimensions	<p><u>VPR100 &amp; VRX100</u>  <i>Bezel:</i> 144 mm (H) x 144 mm (W) x 43 mm (D)                      5.67" (H) x 5.67" (W) x 1.69" (D)  <i>Case:</i> 137 mm (H) x 137 mm (W) x 295 mm (D)                   5.39" (H) x 5.39" (W) x 11.61" (D)</p> <p><u>VRX150</u>  <i>Bezel:</i> 295 mm (W) x 279 mm (H) x 44.45 mm (D)                      11.61" (W) x 10.98" (H) x 1.75" (D)  <i>Case:</i> 137 mm (H) x 137 (W) x 295 mm (D)                   5.39" (H) x 5.39" (W) x 11.61" (D)</p>
Weight	<p><u>VPR100 &amp; VRX100</u>            3.6 kg (8 lbs).</p> <p><u>VRX150</u>            5.4 kg (12 lbs).</p>
I/O Ports Standard	QWERTY Keyboard Connector (5 pin DIN type) – on front panel behind bezel. May be used to connect to QWERTY keyboard or to ASCII Barcode Reader.
Environmental	
Temperature	<p><i>Operating:</i> 0 °C to 50 °C (32 °F to 122 °F).  <i>Storage:</i> –20 °C to 70 °C (–4 °F to 158 °F).  <i>Relative Humidity:</i> 10 % to 90 %, non-condensing at 40 °C.</p>
Altitude	< 2000 meters
Installation Category	II
Pollution Degree	2
Power	Universal supply, 85 to 265 Vac, 50/60 Hz, 45 VA. Optional 24 Vdc supply, 21.6 to 26.4 Vdc, 1.4 A
Fuse Rating	2.0 amp/250 Vac slow blow type. Not replaceable by operator.

continued

Table 1-1 Specifications (continued)

Attributes	
Display	<p>Type: Color LCD active matrix.  Update Rate: 1 second.  Trend Timebase: <b>5 min., 15 min., 30 min., 1 hr., 2 hr., 4 hr., 8 hr., 24 hr., 7 day, 31 day.</b></p> <p><u>VPR100 &amp; VRX100</u>  Screen Size: 139.7 mm (5.5" diagonal)  Resolution: 320 x 240 pixels.</p> <p><u>VRX150</u>  Screen Size: 264.2 mm (10.4") diagonal  Resolution: 640 x 480 pixels.</p>
Keys	12 membrane keys.
Data Storage	<p>Media: 1.44 or 120 Mbyte disk.  Data Types: Analog points, calculations, discrete status, alarms, diagnostics.  Trends: VRX100/VPR100: 3 max (6 points max. each)  VRX150: <b>4 trends max (12 points max. each)</b>  Unit Data: 1 (up to 12 points, 10,000 records).  Trend &amp; Unit Data combined point capacity: 30 (VPR/VRX100) 48 (VRX150)  Alarm History: Up to 1600 records  Event History: Up to 1600 records  Diagnostic History: Up to 1600 records  Setpoint Programs: 224 maximum on 3.5" floppy disk. Programs must be stored on a separate disk from Data Trend Storage information.  Storage Rate Range: 0.25 to 3600 sec.  Capacity: Automatically calculates storage time based on storage rate.</p>
Control Loops	<p>Number: Up to 4.  Type: PID, On/Off, Cascade, Split Output, Ratio, DIAT</p>
Auto Tune	Each loop can be pre-tuned automatically to establish acceptable tuning parameters. On-line fuzzy overshoot suppression.
Setpoint Program Capability	
Number of Programs	Memory can store 96 programs for a single channel programmer, 48 programs for a dual channel programmer, 32 programs for a three channel programmer, and 24 for a four channel programmer. Programs can also be stored to floppy disk. Programmer has ability to start a program at a predetermined time.
Number of Segments	63 segments per profile
Ramping Capability	Ramp X - Ramp rate is set by specifying x degrees per second, per minute, or per hour.
	Ramp T - Ramp rate is set by selecting the time to go from previous setpoint to next setpoint in t time.
	Ramp E - Ramp rate is set to increment by $\Delta SP$ for every pulse of a digital input.
	Value Duration Ramp - Ramp rate is based on the start value of the ramp and the time specified to reach the next soak start value.
Ramp Time Range	0-9,999,999 hours, minutes, or seconds.

Table 1-1 Specifications (continued)

Setpoint Program Capability (continued)	
Soak	Guaranteed or non-guaranteed. Can be applied to ramp or soak segment or across entire profile/program.
Soak time range	0-9,999,999 hours, minutes, or seconds.
Program Cycling	Entire programs or portions of a program can be cycled up to 99 times. Loops can be nested up to 4 deep.
Startup/Shutdown	Can be set up to use a predefined startup profile separate from the normal processing programs. Shutdown profile can be attached to the end of a profile and can be jumped to for emergency shutdown.
PV Hot Start	Can start the profile at the point where the present PV value first intersects the profile.
Batch Programming	1 to 255 Batch numbers. Batch number is assigned by the programmer and is incremented automatically when batch is started.  Using a keyboard or bar code reader and the front keyboard connector, a batch can be labeled with a name of up to 8 characters.
Profile Events	Up to 16 events can be defined in each segment of a profile. Each event's state is activated at the beginning of the segment and is held throughout the segment.
Analog Inputs	
Number	Up to 6 universal, up to 12 TC/EMF and Pyrometer only.
Input Types	Universal types are EMF (mV, V, mA via shunt), Thermocouple, RTD and Pyrometer.
All Types	<i>Resolution:</i> 15 bits (14 bits plus sign). <i>Scan Rate:</i> 250 msec for 2 inputs, and 2 control loops and 2 Profilers and 12 Calc. Values 500 msec for 8 inputs and 4 control loops and 4 Profilers and 32 Calc. Values 1 sec for 12 inputs and 4 control loops and 4 Profilers and 32 Calc. Values <i>Isolation:</i> Fully isolated <i>Normal Mode Rejection:</i> 60 dB (1,000:1). <i>Common Mode Rejection:</i> 120 dB (1,000,000:1) (@ 100 ohm source). <i>Normal Mode Voltage Limit:</i> RMS equal to high span limit (@ mains/line frequency). <i>Input Impedance:</i> >20 megaohms. <b>1 megaohms when using the following ranges: 0-10V, +/-10V, 0-20V, +/-20V.</b> <i>Accuracy:</i> See Table 1-2 and Table 1-3. <i>Temperature Effects:</i> See Table 1-3. <i>Ranges:</i> Assigned per point based on range table. See Table 1-2 and Table 1-3.
TC/EMF	<i>Source Resistance Error:</i> 0.3 microvolts per 100 ohms. <i>Reference Junction Error (TC only):</i> 0.3 °C (0.5 °F). <i>Open Input Check:</i> Bleeder type (upscale, downscale, off).
RTD	<i>Excitation Current:</i> 0.15 mA. <i>Switching:</i> Common "B" lead. <i>Maximum Lead Resistance:</i> 5 ohms.

Table 1-1 Specifications (continued)

Analog Outputs	
Number	Up to <b>4</b> current outputs. Additional time prop. Outputs (DAT) available. Total maximum of 8 analog outputs.
Type	Current output (CAT), Voltage output (VAT) (customer selectable with internal switch), Time Proportion output (DAT), Position Proportional (PP), Direction Impulse Adjusting Type (DIAT).
CAT (Current Adjusting Type)	<i>Current:</i> Selectable from 0 to 20 mA. <i>Maximum Load:</i> 800 ohms maximum per CAT output. <i>Isolation:</i> Isolated, 30 Vdc peak (input to ground) <i>Resolution:</i> 12 bits, 0.025 %.
VAT (Voltage Adjusting Type)	<i>Voltage:</i> Selectable between 0 and 5 Volts. <i>Minimum Load:</i> 1000 ohms. <i>Isolation:</i> Isolated, 30 Vdc peak (input to ground) <i>Resolution:</i> 12 bits, 0.025 %.
DAT (Duration Adjusting Type)	Uses any discrete output relay or open collector output. <i>Impulse Time:</i> $\geq 1$ <i>Resolution:</i> 4.0 msec. <i>Minimum Off Time:</i> Off, $\geq 0$ <i>Minimum On Time:</i> Off, $\geq 0$
Pos Prop (Position Proportional Type)	Up to 4 available. 4 Position Proportional outputs requires use of open collector outputs; each output requires use of dedicated analog input Slidewire resistance: 100 ohms to 1000 ohms Drive unit speeds: 10 seconds to 220 seconds
DIAT (Direction Impulse Adjusting Type)	3 maximum using instrument's discrete output hardware. 4 DIAT outputs requires use of external relays. Drive unit speeds 10 seconds to 220 seconds.
Transmitter Power Supply (Standard Output)	
	24 Vdc, 90 mA max.
Discrete Inputs/Outputs	
Combinations available	3 DIs/4 DOs (Relay Outputs) 6 DOs (Relay Outputs) 8 DIs/8 DOs (Open Collector Outputs) 16 DIs/16 DOs (Open Collector Outputs) 8 DIs/24 DOs (Open Collector Outputs)
Inputs	<i>Type:</i> Dry contact actuation. <i>Input Level:</i> 24 Vdc, 15 mA (internally supplied). <i>Isolation:</i> 30 volts point-to-ground.
Relay Outputs	<i>Type:</i> Form C. <i>Max Switch Current:</i> 14/5 (NO/NC) Amps, 120 Vac resistive <i>Max Switch Voltage:</i> 265 Vac <i>Max Switch Power:</i> 200W, dc; 2000 VA, ac <i>Max Carrying Current:</i> 2 Amps @ 250 Vac; 5 Amps @ 120 Vac, 2 Amps @ 24 Vdc.



Table 1-1 Specifications (continued)

Discrete Inputs/Outputs (continued)	
Solid State AC Outputs	<p><i>Type:</i> Form A contacts.</p> <p><i>Max Output Current:</i> 2 Amps.</p> <p><i>Voltage Range:</i> 12-280 Vac.</p> <p><i>Minimum Current:</i> 20 mA.</p> <p><i>Switchbase:</i> Zero-crossing.</p>
Solid State DC Outputs	<p><i>Type:</i> Form A contacts.</p> <p><i>Max Output Current:</i> 2 Amps.</p> <p><i>Voltage Range:</i> 5-60 Vdc.</p> <p><i>Minimum Current:</i> 20 mA.</p>
Open Collector Outputs	Open transistor collector output rated at 30 Vdc max, 100 mA max. User must provide a relay for each output along with external 24 Vdc power supply for the relays.
Digital Input Capability	<p>3, 8, or 16 Digital Inputs</p> <p>Digital Inputs capable of Run, Hold, Reset, Jump, Segment Advance, Guaranteed Soak, Switch to Second input (PV Channel Select), Auto/Manual Select, Batch Start/Stop, Event mark of data, Fast Forward, PV Hot Start, Remote Program Selection. Can be used in logic operators.</p>
Digital Output Capability	<p>4 or 6 Relay Outputs; 8, 16 or 24 Open Collector Outputs</p> <p>Digital Outputs can be triggered by Alarms, Program Status, Diagnostics, Math Result, Logic Result, or DAT Control Outputs.</p>
Performance/Capacities	
Math Calculations	<p><i>Standard Math includes:</i> 8 Calculated Values along with the following Math functions: Free Form Math, Math Operators (+, -, x, ÷, Absolute Value, Square Root, Std. Deviation), Free Form Logic, Logic Operators (AND, OR, XOR, Inverter, Flip Flop, One-Shot), Periodic Timer. Logic gates can accept up to 8 inputs.</p> <p><i>VPR100 only Math Level 1 includes:</i> 16 Calculated Values with the functions from Standard Math along with the following types of pre-packaged algorithms: Signal Select, Compare, Signal Clamp, Interval Timer, Counter, Relative Humidity, Standard Splitter, Scaling.</p> <p><i>Math Level 2 includes:</i> 32 Calculated Values with the functions and algorithms from Standard Math and Math Level 1, along with the following types of pre-packaged algorithms: Peak Picking, Function Generator, Rolling Average, Carbon Potential, Mass Flow, F0 Calculation, Multiple Input Average, Single Point Average, Advanced Splitter, Continuous Emissions Block Average and Rolling Average.</p>
Constants	Up to 16
Alarms	Up to 16
Totalizers	Up to 3 optional (VPR100), up to 12 optional (VRX100 & VRX150).
Control Loops	<p><i>Number:</i> Up to 4.</p> <p><i>Type:</i> PID, On/Off, Cascade, Split Output, Ratio, DIAT</p>

**Table 1-1 Specifications** (continued)

Performance/Capacities (continued)	
Primary Displays	<p>Up to 10 displays may be assigned from the following formats: Vertical Trend, Vertical Trend Digital, Horizontal Trend, Horizontal Trend Digital, Horizontal Trend Bar, 3pt Vertical Bar Graph, 6pt. Vertical Bar Graph, Panel Display, Unit Data, Panel Meter, Alarm Summary, Storage Status, Totalizer, Loop w/Bar Graph, Loop w/2 Bar Graphs, Loop w/3 Bar Graphs, Loop w/4 Bar Graphs, Setpoint Profiler w/2 Bar Graphs, Setpoint Profiler w/3 Bar Graphs, Setpoint Profiler Trend.</p> <p><i>The VRX150 has these additional formats:</i></p> <p>Panel Display w/4 Large Fonts (instead of Panel Display), Setpoint Profiler w/4 Bar Graphs, Vertical Trend Digital, 4 pt. Vertical Bar Graph (instead of 3 pt.), Vertical Trend Bar, 4 pt. Horizontal Bar Graph (instead of 3 pt.), 6 pt. Horizontal Bar Graph, Process Summary</p>
Support Displays	13 (menu access).
Communications (optional)	<p><i>Type:</i> RS-422/485, Honeywell Binary Modbus™ RTU protocol</p> <p><i>Connection:</i> 2 twisted pairs with shield (5 wires).</p> <p><i>Distance:</i> 600 meters, (2000 feet).</p> <p><i>Number of links:</i> Up to 30</p> <p><i>Baud Rate:</i> 1200, 2400, 4800, 9600, 19.2K, 38.4K, 76.8K.</p> <p><i>Parity:</i> Selectable; odd, even, none.</p>
Optional Software Accessories	
SDA	Data Analysis Software
SCF	Configuration Software

**Table 1-2 Analog Input Accuracy--Linear types**

Input Range	Accuracy at Calibration Temperature		
	+/- Accuracy		+/- Temperature Effects
	% Range	mV	
-25 to 25 mV	0.02	0.01	0.003 mV per °C
-75 to 75 mV	0.02	0.03	0.009 mV per °C
-200 to 1000 mV	0.02	0.24	0.037 mV per °C
-200 to 5000 mV	0.03	1.56	0.150 mV per °C
0 to 10 V	0.5	50	1.86 mV per °C
-10 to 10 V	0.5	100	0.045 mV per °C
0 to 20 V	0.5	100	1.86 mV per °C
-20 to 20 V	0.5	200	0.255 mV per °C

Table 1-3 Analog Input Accuracy--Non-linear types

Type	Accuracy at Calibration Temperature							
	Operating Span <sup>1</sup>		+/- Accuracy			+/- Temperature Effects		
	°F	°C	% Range	°F	°C	mV per °F	mV per °C	
<b>Thermocouples - ITS-90 except where noted</b>								
J	<i>0</i> to <i>2190</i>	<i>-18</i> to <i>1199</i>	0.1	2.2	1.2	0.005	0.009	
K	<i>0</i> to <i>2500</i>	<i>-18</i> to <i>1371</i>	0.1	2.5	1.4	0.005	0.009	
E	<i>-450</i> to <i>-241</i> <i>-240</i> to <i>1830</i>	<i>-268</i> to <i>-152</i> <i>-151</i> to <i>999</i>	0.6 0.1	13.7 2.3	7.6 1.3	0.005	0.009	
T	<i>-300</i> to <i>-1</i> <i>0</i> to <i>700</i>	<i>-184</i> to <i>-19</i> <i>-18</i> to <i>371</i>	0.3 0.1	3.0 1.0	1.7 0.6	0.002	0.003	
N	<i>0</i> to <i>2372</i>	<i>-18</i> to <i>1300</i>	0.1	2.4	1.3	0.005	0.009	
B	<i>110</i> to <i>949</i> <i>950</i> to <i>3300</i>	<i>43</i> to <i>509</i> <i>510</i> to <i>1816</i>	1.2 0.1	38.3 3.2	21.3 1.8	0.002	0.003	
R	<i>0</i> to <i>3210</i>	<i>-18</i> to <i>1766</i>	0.1	3.2	1.8	0.002	0.003	
S	<i>0</i> to <i>3210</i>	<i>-18</i> to <i>1766</i>	0.1	3.2	1.8	0.002	0.003	
W5/W26 <sup>2</sup>	<i>0</i> to <i>4200</i>	<i>-18</i> to <i>2316</i>	0.1	4.2	2.3	0.005	0.009	
PLAT II <sup>2</sup>	<i>-100</i> to <i>2500</i>	<i>-73</i> to <i>1371</i>	0.1	2.6	1.4	0.005	0.009	
NI-NIMO	<i>32</i> to <i>2502</i>	<i>0</i> to <i>1372</i>	0.1	2.5	1.4	0.005	0.009	
<b>RTD</b>								
CU10 <sup>3</sup>	<i>-100</i> to <i>155</i> <i>156</i> to <i>310</i>	<i>-73</i> to <i>68</i> <i>69</i> to <i>154</i>	0.1 0.2	0.4 0.8	0.2 0.4	0.005	0.009	
PT100 <sup>2</sup>	<i>-300</i> to <i>1570</i>	<i>-184</i> to <i>854</i>	0.1	1.9	1.1	0.005	0.009	
<b>Pyrometry (Rayotube &amp; Spectray) Types</b>								
18890-3302	<i>750</i> to <i>1600</i>	<i>399</i> to <i>871</i>	0.1 typical	0.8	0.4	0.002	0.003	
18890-0073	<i>800</i> to <i>1800</i>	<i>427</i> to <i>982</i>	0.1 typical	1.0	0.5	0.002	0.003	
18890-0074	<i>1100</i> to <i>2300</i>	<i>594</i> to <i>1260</i>	0.1 typical	1.2	0.6	0.002	0.003	
18890-0035	<i>1200</i> to <i>2600</i>	<i>649</i> to <i>1426</i>	0.1 typical	1.4	0.7	0.002	0.003	
18890-0412	<i>1375</i> to <i>3000</i>	<i>747</i> to <i>1648</i>	0.1 typical	1.6	0.9	0.002	0.003	
18890-0075	<i>1500</i> to <i>3300</i>	<i>816</i> to <i>1815</i>	0.1 typical	1.8	1.0	0.002	0.003	
18890-1729	<i>1650</i> to <i>3600</i>	<i>899</i> to <i>1982</i>	0.1 typical	0.9	1.0	0.002	0.003	
18890-00643	<i>1850</i> to <i>4000</i>	<i>1010</i> to <i>2204</i>	0.1 typical	2.2	1.2	0.002	0.003	
18890-0216	<i>2110</i> to <i>4600</i>	<i>1155</i> to <i>2537</i>	0.1 typical	3.5	1.4	0.002	0.003	
18890-5423	<i>2210</i> to <i>5000</i>	<i>1210</i> to <i>2760</i>	0.1 typical	3.8	1.5	0.002	0.003	
18890-0163	<i>200</i> to <i>1000</i>	<i>94</i> to <i>537</i>	0.1 typical	0.8	.4	0.002	0.003	
18899-8814	<i>340</i> to <i>1800</i>	<i>172</i> to <i>982</i>	0.1 typical	1.4	.81	0.002	0.003	
18894-9014	<i>752</i> to <i>2552</i>	<i>400</i> to <i>1400</i>	0.1 typical	1.7	1.0	0.002	0.003	
18894-0579	<i>752</i> to <i>2552</i>	<i>400</i> to <i>1400</i>	0.1 typical	1.7	1.0	0.002	0.003	
Spectray 18885	<i>1832</i> to <i>3452</i>	<i>1000</i> to <i>1900</i>	0.1 typical	1.6	0.9	0.005	0.009	
Spectray 18885-1	<i>1292</i> to <i>2912</i>	<i>700</i> to <i>1600</i>	0.1 typical	1.6	0.9	0.005	0.009	
Spectray 18885-2	<i>806</i> to <i>1400</i>	<i>430</i> to <i>760</i>	0.1 typical	0.6	0.3	0.005	0.009	
Spectray 18886	<i>1833</i> to <i>3452</i>	<i>1001</i> to <i>1900</i>	0.1 typical	1.6	0.9	0.005	0.009	
Spectray 18886-1	<i>1292</i> to <i>2912</i>	<i>700</i> to <i>1600</i>	0.1 typical	1.6	0.9	0.021	0.037	
18874-0578	<i>752</i> to <i>2552</i>	<i>400</i> to <i>1400</i>	0.1 typical	1.7	1.0	0.083	0.150	
18875-0579	<i>752</i> to <i>2552</i>	<i>400</i> to <i>1400</i>	0.1 typical	1.7	1.0	0.083	0.150	
<p><sup>1</sup> <i>Italicized values indicate overall input range.</i></p> <p><sup>2</sup> <i>IPTS-68</i></p> <p><sup>3</sup> <i>Accuracy for the calibrated channel. The factory calibrates channel #1. If calibrated on channel #1 channel #6 may be as much as 5.0 Degrees F higher. If using all 6 inputs for CU10 it is recommended to field calibrate on channel #3 or channel #4 to minimize the correction needed. Use Analog Input Value Adjust screen to compensate the other channels.</i></p>								

**Table 1-4 Standards**

This product is designed and manufactured to be in conformity with applicable U.S., Canadian, and International (IEC/CENELEC/CE) standards for intended instrument locations. The following Standards and Specifications are met or exceeded.

Case Protection (VPR100 & VRX100 only)	With the proper panel mounting with the required gasketing and with the front bezel firmly closed, the instrument meets the criteria for NEMA Type 3 Enclosure for protection from rain and sleet as described in NEMA Standard 250-1991 Sec. 6.4.2.2.
Rear of Panel	IEC 529, IP 20; EN 60529, IP 20
Flammability Rating	UL 94 - V2
Vibration Level	5 to 15 Hz, 1mm displacement; 15 to 150 Hz, 0.5g acceleration
Electromagnetic Compatibility	CE EMC Directive 89/336/EEC
Safety	CE Low Voltage Directive 73/23/EEC ( EN 61010-1). For US, ANSI/ISA S82-1994. For Canada, CAN/CSA - C22.2 No. 1010.1-92
Intended Instrument Locations	Rack or panel mounting in control room or industrial environments (operator accessibility front of panel only)  Installation Category II with grounded mains supply from isolation transformer or GFI (ground fault interrupter)  Pollution Degree 2 with rear of panel enclosed, in industrial environment

## 1.7 Model Number

In the nameplate on the outside of the case, the Model Number identifies the content and configuration of your instrument. Refer to the Model Selection Guide for product restrictions and ordering an instrument.

### VPR Model Number

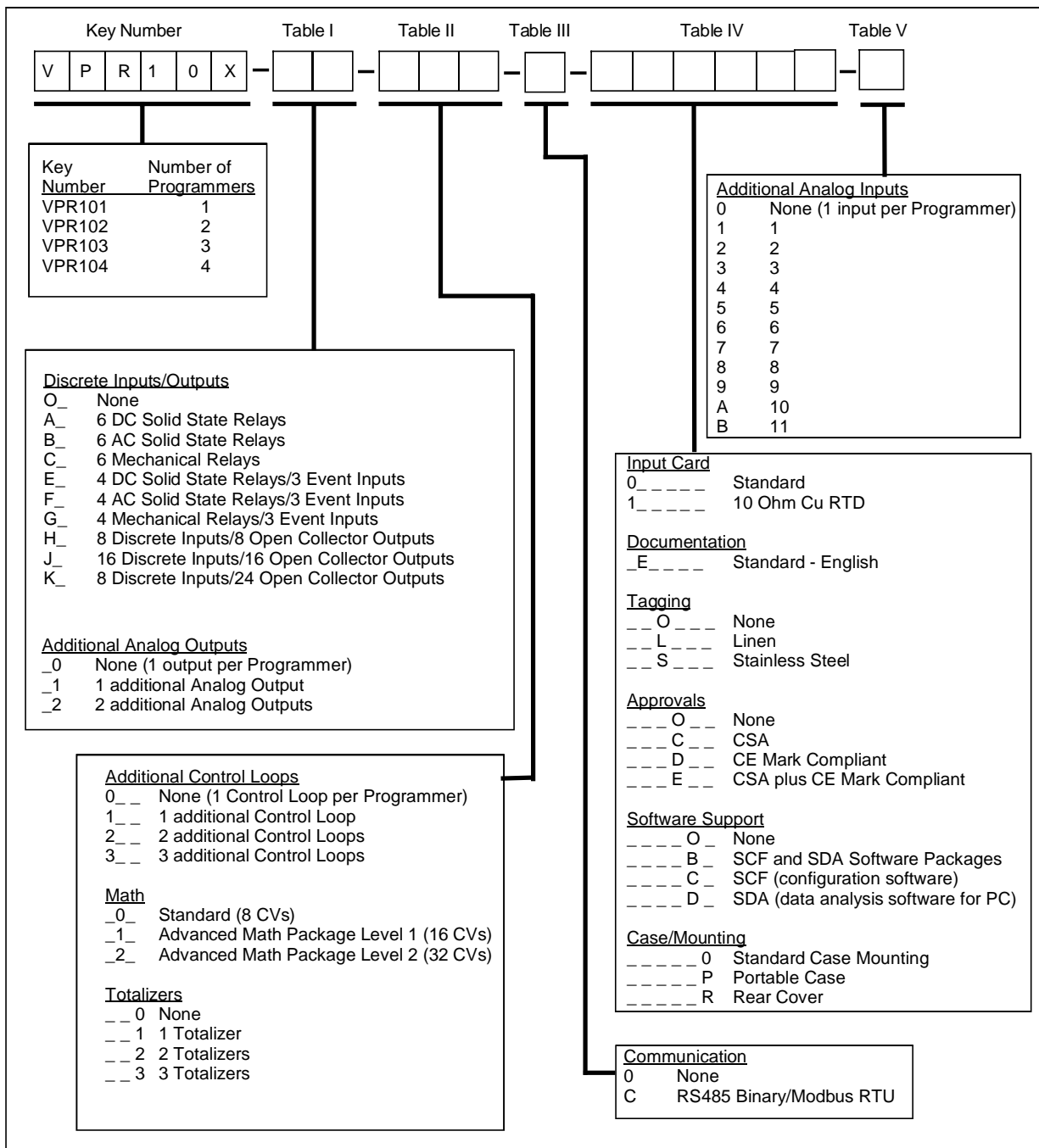


Figure 1-5 VPR Model Number

VRX100/150 Model Number

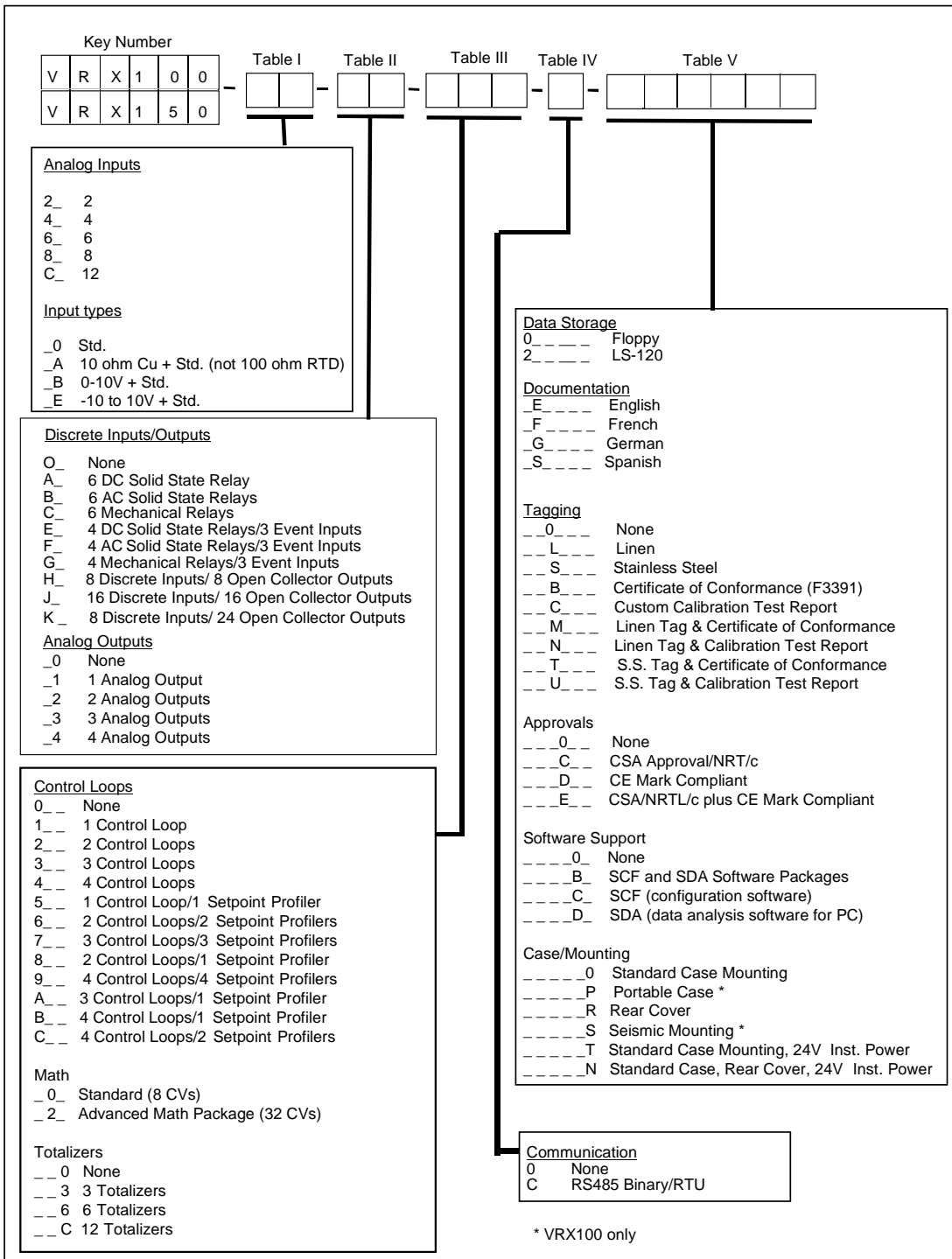


Figure 1-6 VRX100/VRX150 Model Number

## 2. Installation

### What's in this section?

The following topics are covered in this section.

Topic	Page
Installing optional DSU software	15
Site preparation	15
Location	16
Mounting	16
Wiring	20

### ATTENTION

If the instrument is used in a manner not specified by Honeywell, the protection provided by the instrument may be impaired.

### 2.1 Installing optional DSU software

If your instrument is equipped with the optional 120MB or Zip disk drive, you should have received a floppy disk containing DSU.EXE, the Data Storage Utility. This software lets you use your PC to initialize 120MB or Zip disks for data storage in a fraction of the time it would take on the instrument.

To install the DSU.EXE onto your PC, simply copy the program onto your hard drive. You can create a folder called "DSU" if you want.

### 2.2 Site Preparation

The instrument is a complex electronic device measuring low level electrical signals. Proper site preparation and installation practices are important in achieving a trouble-free system. Our experience indicates that many problems are the result of improper installation. Follow the procedures and recommendations in this section to ensure a successful installation.

Consider the following items for each installation:

- Physical mounting and location
- Power line (mains) conditioning
- Grounding for personal safety
- Grounding for noise immunity
- Suppression of noise from electrically connected loads
- Suppression of noise from nearby (not connected) sources
- Proper connections and terminations of communications links

## 2.3 Location

Install the instrument in a control panel located in a control room or in a relatively clean factory environment. It should not be installed in offices or residential locations.

The front of the instrument is gasketed and will provide reasonable protection from dust and moisture when properly installed in a panel.



The instrument must be panel mounted and terminals must be enclosed within panel to maintain safety compliance.

## 2.4 Mounting

Figure 2-1 illustrates how the instrument is attached to a panel. Make the panel cutout as shown in Figure 2-1. Note that the panel may be up to 19.05 mm (0.75") thick.

To mount the instrument to the panel, follow the procedure in Table 2-1. Note: For instruments with the seismic mounting option, refer to the separate mounting instructions.

**Table 2-1 Panel Mounting Procedure**

Step	Action
1	Place the instrument in the panel cutout as shown in Figure 2-1 or Figure 2-2.
2	Remove the screw from the top and bottom rear center of the instrument.
3	Engage the rounded projection on the mounting T-bar in the slot on the top of the instrument's case. Note the end with the notch. For thin panels (up to 7.92 mm (5/16")), place the notched end toward the panel. For thick panels (up to 12.7 mm (1/2")), place the notched end away from the panel. For thicker panels, up to 6.35 mm (1/4") can be cut off the unnotched end.
4	Slide the bar up against the panel and insert the screw at the end of the case as shown. Check the fit and alignment of the instrument and tighten the screws on the top and bottom to 3 LB-IN (.35 N-M) of torque maximum. See Table 2-2 for proper screw length.
5	Install the second T-bar and screw in the slot on the bottom of the case in the same way.
6	Check the fit and alignment of the instrument and tighten the screws on the top and bottom to 3LB-IN (.35 N-m) maximum torque.



### **WARNING**

Use proper screw length to prevent Electric Shock.

**Table 2-2 Screw Lengths for Panel Thicknesses**

For Panel thickness:	Use screw length:
1.52 mm (.06") to 4.8 mm (3/16")	12 mm (15/32")
4.8 mm (3/16") to 8 mm (5/16")	8 mm (5/16")
8 mm (5/16") to 12.7 mm (1/2")	8 mm (5/16")
12.7 mm (1/2") and thicker	8 mm (5/16") and cut t-bar as noted in Step 3 of Table 2-1.



---

### Mounting adjacent instruments (VPR100 & VRX100)

•**Horizontal** – For closest spacing horizontally, spacing of 7 mm (0.28”) will provide zero clearance between bezels of adjacent instruments. For applications where instruments will be opened frequently for access to floppy disk, increase this spacing slightly to avoid the possibility of adjacent instruments touching when opening or closing.

•**Vertical** – Space must be allowed for opening an instrument’s bezel. Recommended vertical spacing is 60 mm (2.37”) between cutouts.

### Seismic Mounting (VRX100)

1. Determine the thickness of the panel (3.18mm/.125” min. - 6.36mm/.250” max.) that the unit will be mounted into.
2. Measure the mounting holes on the angle brackets - Holes that are 13.34mm/.525” from the face of the angle bracket are used for mounting units on panels that are 3.18mm/.125” thick. Holes that are 10.16mm/.400” from the face of angle bracket are used for mounting units on panels that are 6.18mm/.250” thick.
3. Remove the protective backing from one of the gaskets and apply to the face of the angle bracket that will contact the rear of the panel. Repeat the process for the second angle bracket.
4. See Figure 2-1. Place the recorder in the panel cutout. While holding the unit from the front of the panel, attach the top & bottom angle bracket to the aluminum case using (4) M4 Hex Head screws & lockwashers. Torque M4 screws to 7 in-lb.
5. After unit is installed, check to see that unit is held firmly in place. If not, place a 0.80mm/.031” thick shim between the gasket & panel. For panels thickness’ that are between 3.18mm/.125” & 6.18 mm/.250”, shim as required.

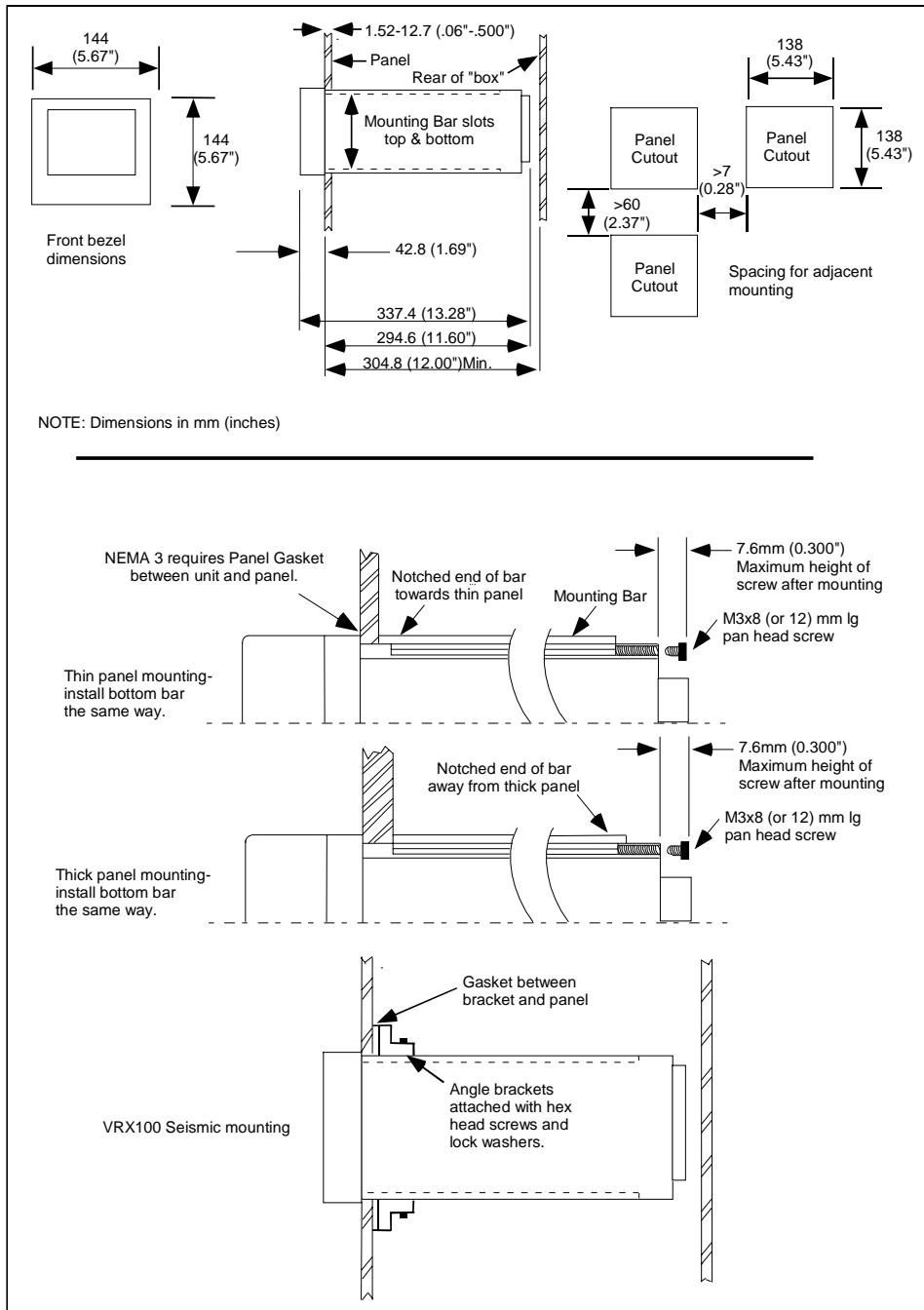


Figure 2-1 VPR100 & VRX100 Mounting

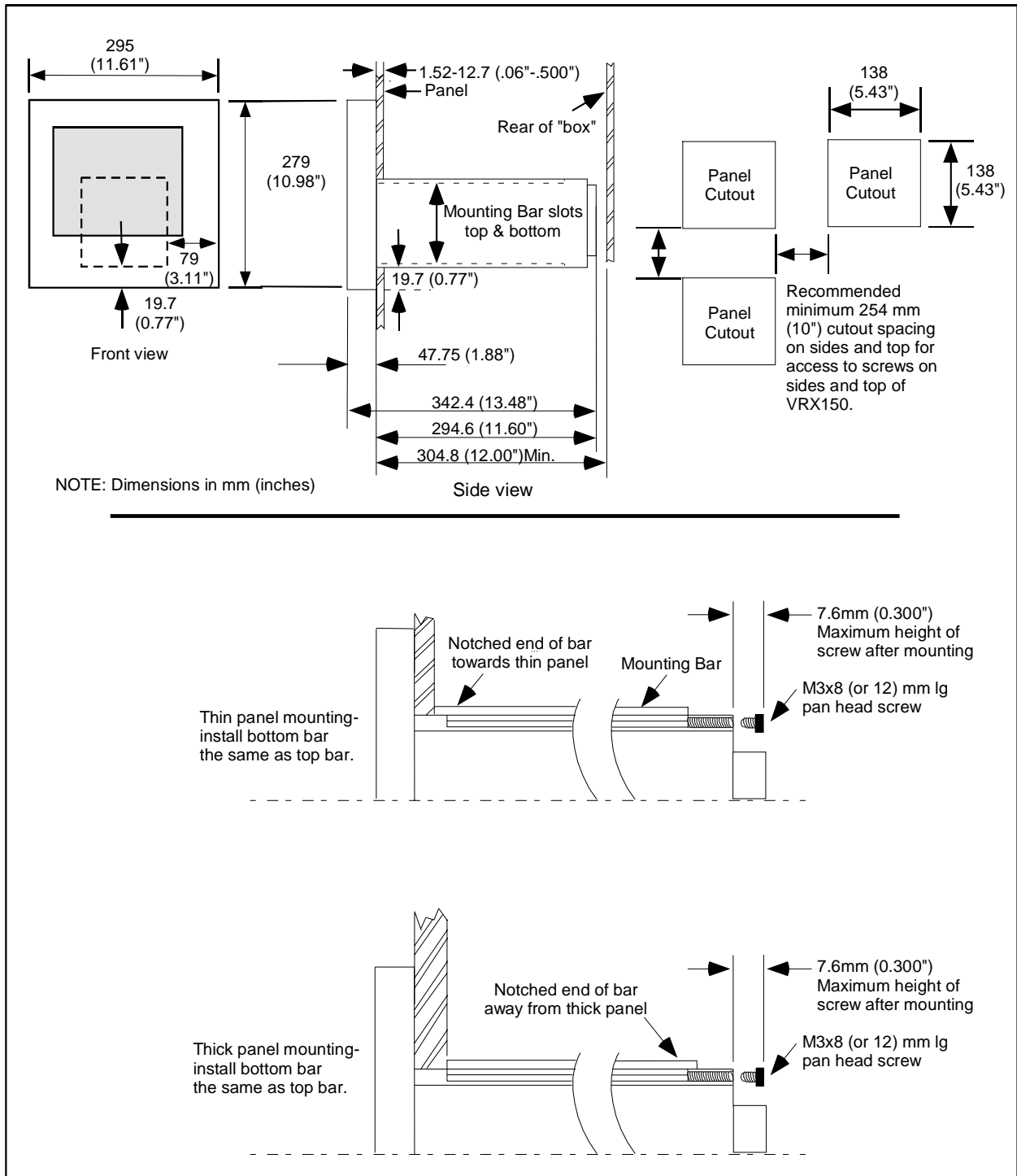


Figure 2-2 VRX150 Mounting

**ATTENTION**

To cover cutouts left by previous instruments, order panel mounting adapter plates (see Table 11-1).

## 2.5 Wiring

This section describes all wiring requirements and procedures.



### CAUTION

All wiring must be done by qualified technicians and must conform to national or local electrical codes.

Do not exceed maximum voltage limits given in Table 1-1.

### Which terminals to connect to?

There are 4 main input/output hardware types: Analog Input (AI1 through AI12), Analog Outputs (AO1 through AO4), Discrete Input (DI1 through DI16), and Discrete Outputs (DO1 through DO 24) (your instrument may have fewer, depending on options ordered). Table 2-3 gives typical applications for each type. Before wiring your process, you must decide which terminals to connect to your process. The terminals you connect to correspond with the software in the instrument. For example, the device you connect to AI1 will be seen by the instrument's software as AI1. If you connect your PV to AI1, then you must remember that AI1 is your PV; the instrument's software has a labeling feature that lets you identify each component by a name of your choice.

Your instrument has the terminals shown in either Figure 2-3, Figure 2-4 or Figure 2-5.

Table 2-3 shows typical applications for the various devices that you connect to the terminals.

**Table 2-3 Terminal Designators And Their Associated Applications**

Terminal designator	Typical application
24V	<ul style="list-style-type: none"> <li>• Power a transmitter</li> <li>• Power relay(s)</li> </ul>
AO	<ul style="list-style-type: none"> <li>• Drive control element(s)</li> <li>• Retransmit to another instrument</li> </ul>
AI	<ul style="list-style-type: none"> <li>• PV(s)</li> <li>• Remote setpoint(s).</li> <li>• Auxiliary input(s) to be recorded.</li> </ul>
DI	<ul style="list-style-type: none"> <li>• Trigger events, like remote operation</li> <li>• Remote selection of parameters</li> </ul>
DO	<ul style="list-style-type: none"> <li>• Alarm outputs</li> <li>• Event outputs</li> <li>• Control outputs</li> </ul>

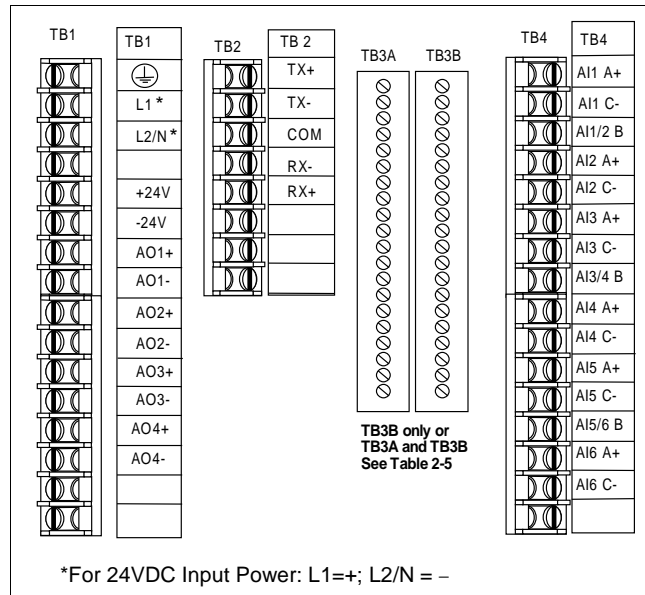
### ATTENTION

Refer to Section B.4 for more details and recommended wiring practices.

**ATTENTION**

For CE Instruments:

The connection between protective earth ground (TB1 Pin1) and Earth Ground for the Communications connection (TB2 Pin 6) is essential for CE compliance with Communications. This wire is installed at the factory, be sure not to remove it.



**Figure 2-3 Terminal Connections (TB3)**

**Table 2-4 Optional Cards for Terminal Board TB3**

Contents of cards					
TB3					
6 AC Solid State Relays	6 Mechanical Relays (Form C)	6 DC Solid State Relays	4 Mechanical Relays/ 3 Event Input Relays	4 AC Solid State Relays/ 3 Event Input Relays	4 DC Solid State Relays/ 3 Event Input Relays
			DI1	DI1	DI1
	DO6 NC		DI1/2 C	DI1/2 C	DI1/2 C
DO6 NO	DO6 NO	DO6 NO (-)	DI2	DI2	DI2
DO5/6 C	DO5/6 C	DO5/6 C (+)	DI3 C	DI3 C	DI3 C
	DO5 NC		DI3	DI3	DI3
DO5 NO	DO5 NO	DO5 NO (-)			
	DO4 NC		DO4 NC		
DO4 NO	DO4 NO	DO4 NO (-)	DO4 NO	DO4 NO	DO4 NO (-)
DO3/4 C	DO3/4 C	DO3/4 C (+)	DO3/4 C	DO3/4 C	DO3/4 C (+)
	DO3 NC		DO3 NC		
DO3 NO	DO3 NO	DO3 NO (-)	DO3 NO	DO3 NO	DO3 NO (-)
	DO2 NC		DO2 NC		
DO2 NO	DO2 NO	DO2 NO (-)	DO2 NO	DO2 NO	DO2 NO (-)
DO1/2 C	DO1/2 C	DO1/2 C (+)	DO1/2 C	DO1/2 C	DO1/2 C (+)
	DO1 NC		DO1 NC		
DO1 NO	DO1 NO	DO1 NO (-)	DO1 NO	DO1 NO	DO1 NO (-)

Note: Terminal label may contain options not installed on your instrument.

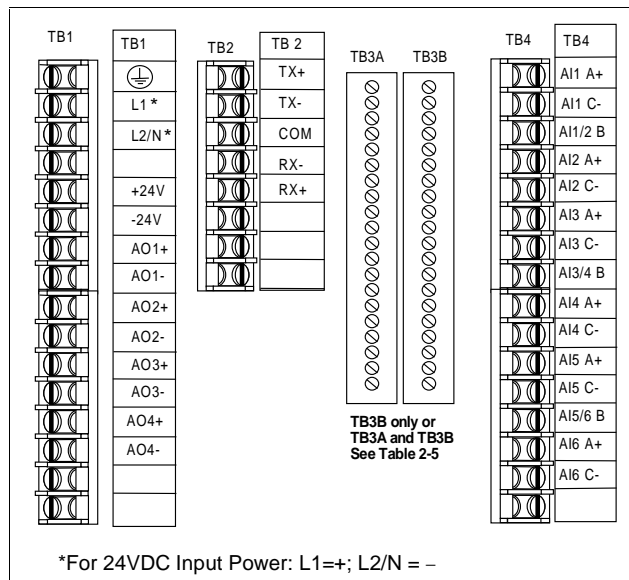
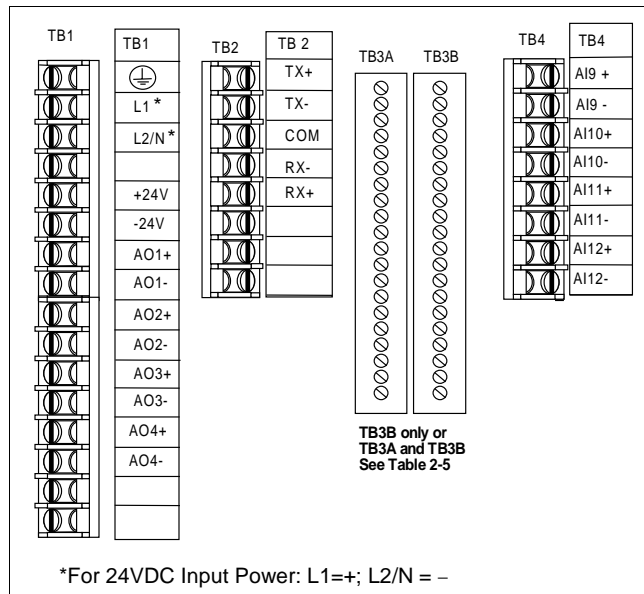


Figure 2-4 Terminal Connections (TB3A & TB3B)

Table 2-5 Optional Cards for Terminal Boards TB3A & TB3B

Contents of cards				
8 DI/8 Open Collector Outputs	16 DI/16 Open Collector Outputs		8 DI/24 Open Collector Outputs	
TB3B	TB3A	TB3B	TB3A	TB3B
DI1	DI9	DI1	DO9	DI1
DI2	DI10	DI2	DO10	DI2
DI3	DI11	DI3	DO11	DI3
DI4	DI12	DI4	DO12	DI4
DI5	DI13	DI5	DO13	DI5
DI6	DI14	DI6	DO14	DI6
DI7	DI15	DI7	DO15	DI7
DI8	DI16	DI8	DO16	DI8
COM	COM	COM	COM	COM
COM	COM	COM	COM	COM
COM	COM	COM	COM	COM
COM	COM	COM	COM	COM
DO1	DO17	DO1	DO17	DO1
DO2	DO18	DO2	DO18	DO2
DO3	DO19	DO3	DO19	DO3
DO4	DO20	DO4	DO20	DO4
DO5	DO21	DO5	DO21	DO5
DO6	DO22	DO6	DO22	DO6
DO7	DO23	DO7	DO23	DO7
DO8	DO24	DO8	DO24	DO8

Note: terminal label may contain options not installed on your instrument.



**Figure 2-5 Terminal Connections (TB3A & TB3B)**

**Table 2-6 Optional 12 PT AI Card Terminal Boards TB3A & TB3B**

Contents of 12 pt AI Card	
TB3A	TB3B
DI1	AI1+
DI2	AI1-
DI3	AI2+
DI4	AI2-
DI5	AI3+
DI6	AI3-
DI7	AI4+
DI8	AI4-
COM	RJ C
COM	RJ O
COM	RJ I
COM	RJ I
DO1	AI5+
DO2	AI5-
DO3	AI6+
DO4	AI6-
DO5	AI7+
DO6	AI7-
DO7	AI8+
DO8	AI8-

### General Wiring Recommendations

In general, use stranded copper wire for non-thermocouple electrical connections. Keep in mind that the maximum load resistance for many process instruments includes the interconnecting wire. Separation of low level and high level wiring is recommended.

Twisted signal pairs and shielded cable will improve noise immunity if wire routing is suspect.

Observe all national and local electrical codes when making power connections. Unless local electrical codes dictate otherwise, the recommended minimum wire size for connections is given in Table 2-7.

**Table 2-7 Recommended Minimum Wire Size**

Gage No.	Description
14	Earth ground wire to common power supply. Earth ground wire to single instrument, AC line leads, +24V and common leads, 24VDC power supply
20	DC current and voltage field wiring
22	DC current and voltage wiring in control room

Make all connections at the terminals outside the case as shown in Figure 2-3 through Figure 2-5 and Table 2-4 through Table 2-6. Do not run low level signal leads close to or parallel with line voltage leads or other power leads, in order to avoid electrical interference with signals.



A mains disconnect switch must be installed that breaks all current carrying conductors.



An external switch should be used for all other hazardous voltage connections.



Disconnect all power before making any wiring connections. More than one switch may be required to de-energize the instrument.

### Power Connections

The instrument can be connected to a power mains source of from 85 Vac to 265 Vac (50 Hz or 60 Hz) with no conversion or special installation requirements.



### Safety Grounding

The protective ground terminal is to be connected to the mains supply ground.

### Noise Suppression

To protect the instrument from noise and to comply with CE, see Appendix B.



### Analog Input Connections

See Table 1-1 Specifications for acceptable voltage and current signal inputs. Connect current and voltage inputs to the appropriately labeled terminals as in Figure 2-5.



#### CAUTION

Safety isolation exceeding the safe working level of 30 V RMS (42.4 V peak) is not provided between analog inputs. If the working voltage of *any* analog input exceeds this level, use suitable wire gauge and insulation on *all* analog inputs, and use proper safety precautions when handling all analog input wiring.

#### ATTENTION

1. For current inputs, shunt resistors are **not** provided.
2. When required, current shunts are mounted on these terminals, see Figure 2-5. Use Part No. 311285 for 4-20 mA input conversion to 1-5 V.
3. Thermocouples may be grounded or ungrounded, since each point is isolated using solid state relays.
4. Connect RTD input leads to the proper terminals for the RTD input card. Note that an RTD has three leads. The A, B, and C leads must be equal length and gage, i.e., the same resistance.
5. In the same instrument, avoid the following input ground connections.
  - Both a thermocouple input tied to ground and an RTD input tied to ground. The thermocouple measurement would be incorrect.
  - A thermocouple at a common mode voltage and an RTD tied to ground. The common mode voltage would be connected to the ground.
  - A thermocouple at a common mode voltage and an RTD which is ungrounded. The common mode voltage would be placed on the RTD.

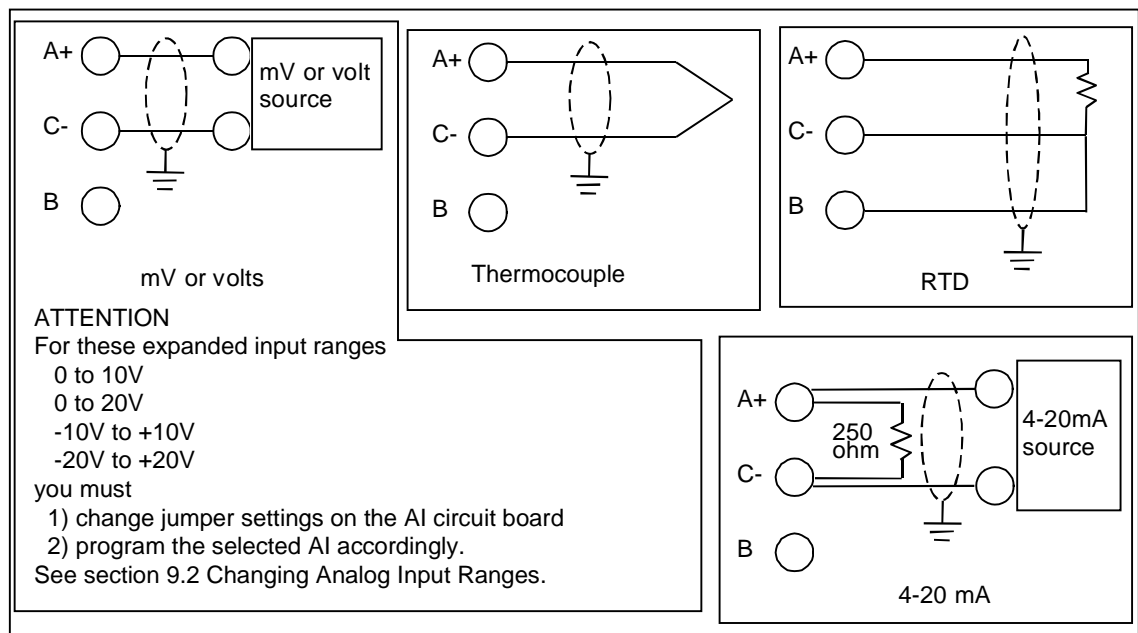
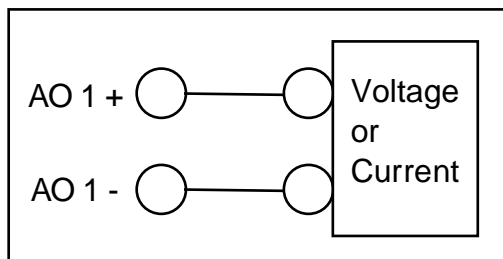


Figure 2-6 Analog Input Wiring Connections

### Analog Output Connections

Analog outputs may be Current Output (CAT), Voltage Output (VAT), Time Proportion Output (DAT) or Position Proportional Type (PP). For CAT or VAT wiring, see Figure 2-7. For DAT wiring, use general purpose output relays or open collector outputs. For Position Proportional wiring, see Figure 2-10. See Discrete Output Connections.

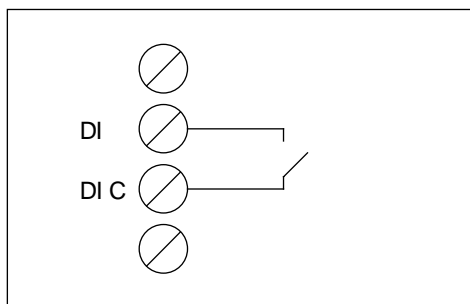
See Table 1-1 Specifications for output signal specifications for output circuit card modules.



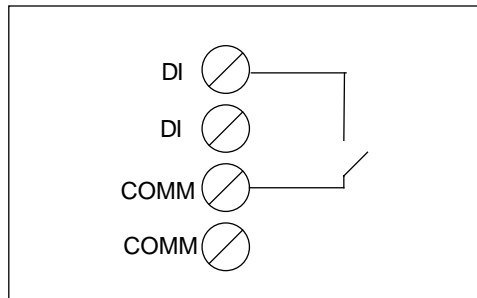
**Figure 2-7 CAT or VAT Wiring Connection**

### Discrete Input Connections

See the Specifications section for input specifications for circuit card modules. Connect the wires according to Figure 2-8 if your instrument has TB3, or Figure 2-9 if it has TB3A or TB3B. For TB3A and TB3B, you can connect to any COMM terminal on the terminal board.



**Figure 2-8 Discrete Input Connections on TB3**



**Figure 2-9 Discrete Input Connections on TB3A & TB3B**

### Discrete Output Connections

The instrument has the following discrete output types.

- Mechanical relay
- Solid state AC/DC
- Open collector

Make connections according to Figure 2-10.

See Table 1-1 Specifications for output signal specifications (switch characteristics) for output circuit card modules.

The solid state relay switches are each optically isolated and also fully isolated from all other outputs. For common power, interconnect all module commons (see Figure 2-10C). Power to all modules is supplied by the user.

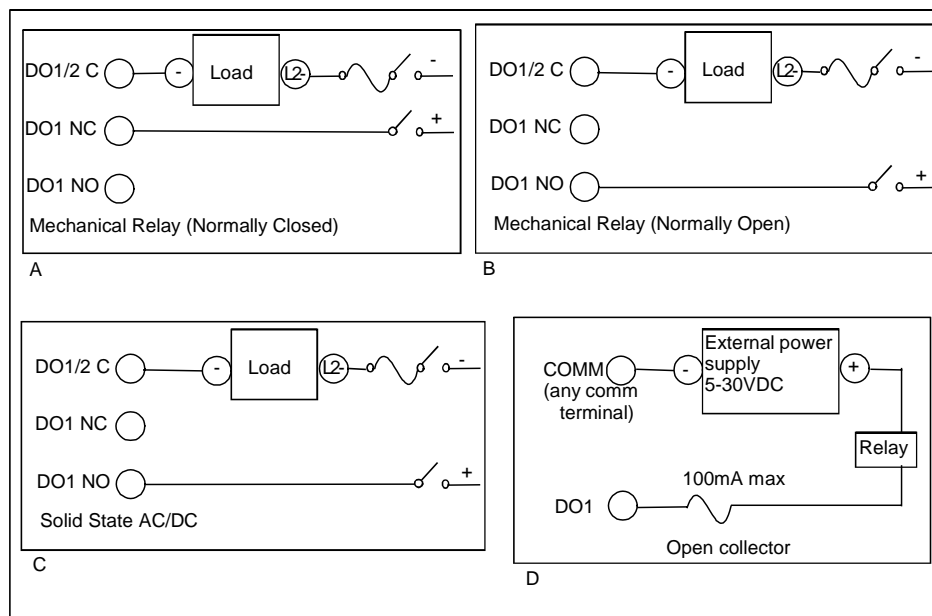
The relay will provide protection by removing power to the outputs whenever system power is lost.

#### ATTENTION

In exceptional cases where the device connected to a relay contact requires a very low nominal energizing current, it is possible that the current through the snubber network capacitor(s) (located on the circuit card and used to protect relay contacts from arcing (when the relay contacts are open)) will be sufficient to continue to energize the relay. To prevent this unwanted energizing, install a load resistor in parallel with the device.

#### ATTENTION

The solid state relays have minimum output current requirements. See solid state relay specifications in Table 1-1. **If these requirements are not met, the discrete output may not turn on.**

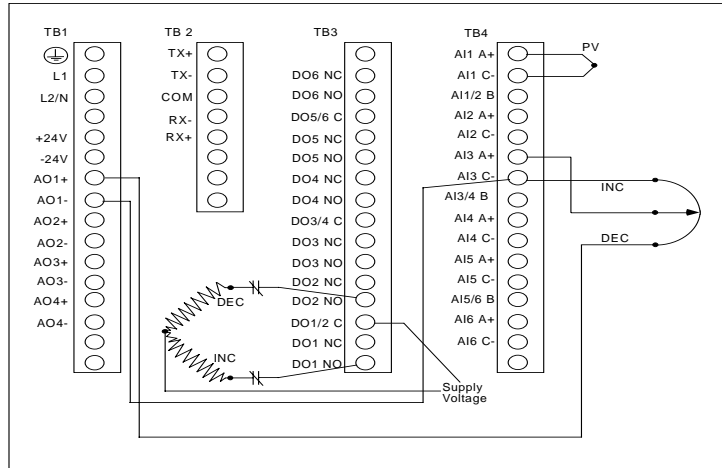


**Figure 2-10 Discrete Output Connections**

Note: Figure 2-10 shows example wiring for DO1 and should be used for any Discrete Output.

**Position Proportional output connections**

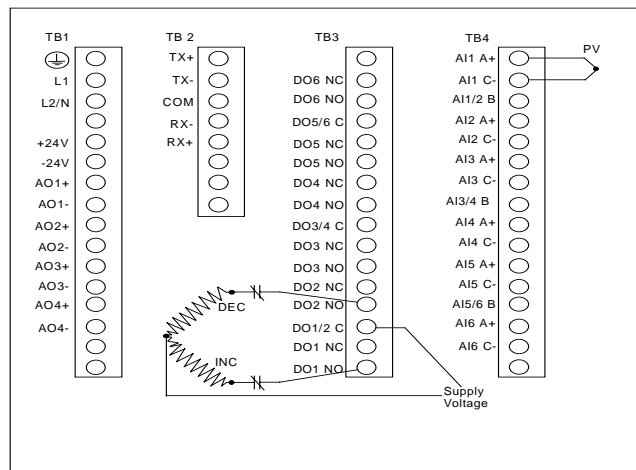
Position Proportional type controls require two analog inputs (PV, Slidewire), two discrete outputs (INC, DEC) and one analog output (Slidewire Power). The analog output must be a voltage type (VAT) programmed to provide a constant 1 V to power the slidewire feedback. See Section 3.13 for sample PP feedback configuration.



**Figure 2-11 Position Proportional Typical Wiring**

**DIAT output connections**

DIAT type control requires 1 analog input (PV) and 2 discrete outputs (INC, DEC). This type of control doesn't require a slidewire.



**Figure 2-12 DIAT Typical Wiring**

## Communications

The communications network is based on Honeywell protocols with a Master/Slave relationship. These are the two protocols available; Binary and Modbus RTU. This network is configured around the IEEE RS-422/485 multi-drop standard. The Master is a PC host running any software compatible with these Honeywell protocols. A slave can be any instrument equipped with serial communications capability. Refer to the product communications manual for additional details on the protocol. Binary: 51-52-25-54 and Modbus RTU: 51-52-25-66.

All communication equipment supporting the 422/485 (differential drive) must be correctly installed and properly terminated to ensure a reliable network.

Table 2-8 shows the five connections per device.

**Table 2-8 Communications Connections**

Connection	Meaning
TX+	The positive signal of the transmitter
TX-	The negative signal of the transmitter
COM	The shield of the communications cable
RX+	The positive signal of the receiver
RX-	The negative signal of the receiver

We recommend using a conduit for each cable, or at least separating them from high voltage lines or magnetic fields.

Table 2-9 shows the communications wiring procedure. See Figure 2-12.

**Table 2-9 Communications Wiring Procedure**

Step	Action
1	Connect the Master's TX signals to each of the RX signals of the Slaves, and all the Slave's TX signals to the Master's RX terminals, plus-to-plus and minus-to-minus.
2	Connect instrument to instrument in a serial or daisy chain fashion with the Master instrument at one end and the last instrument at the other as shown in Figure 2-12.
3	Set only the last instrument's termination ON. All other slave instruments must be unterminated. To change a termination setting, see "Setting The Communications Link Termination Jumper" in Section 9.4 for instructions.

### ATTENTION

For CE compliance, a triple shielded cable (a shield around each of the twisted pairs, (which are tied together and connected to the com. Terminal, TB2 Pin 3) plus an overall shield (the insulated outer shield is connected to TB2 Pin 6, which is then connected to TB1 Pin 1 (earth ground))). The recommended cable of this type is Belden 8728, 80C. **DO NOT** connect the outer shield to the internal shield ground. This will not provide adequate immunity protection.

Required for CE application, but recommended for general use.

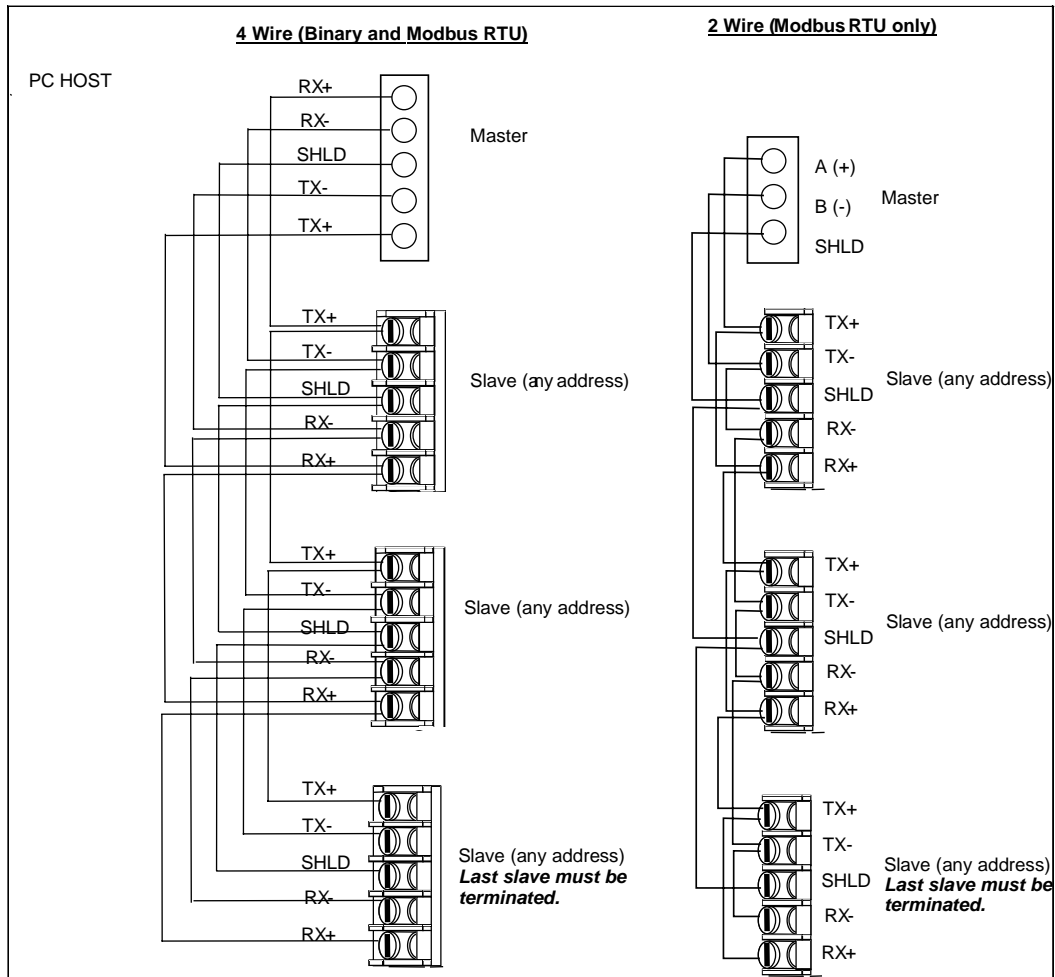


Figure 2-13 Network Data Cable Connections

## 3. Programming and Operating Concepts and Procedures

### 3.1 Overview

This section explains the instrument's programming and operating concepts and procedures. Read and understand this section before attempting to program and operate your instrument.

### 3.2 Quick Start Programming

If you need to get your instrument up and running quickly, you can skip reading the entire manual and instead use the following table as a guide. Keep in mind Section 3 contains basic concepts you should know; consider reading it first.

Step	Action	See
1	To program analog inputs	Section 4.7 Program Analog Inputs
2	To program control (if your application has control)	Section 3.13 How to program common configurations Section 4.8 Program Control Loops Section 5 Setpoint Profiler (if your instrument has a setpoint profiler) Section 4.9 Program Analog Outputs
3	To configure displays	Section 4.18 Program Displays
4	To configure data storage	Section 4.26 Data Storage Setup
5	To program other functions	Remaining sections in Section 4 How To Program Function Blocks and Features

### 3.3 Modes of Operation

The instrument has three modes of operation: Program, Online, and Maintenance. Each mode has its own menus. Most menu items provide access to sub-level menus. The SET MODE item switches the instrument from one mode to another. Your instrument may have reduced menus if options are not present.

#### Program mode

Program mode is an off-line mode for programming (configuring) the instrument. In this mode, all inputs and outputs are frozen.

#### Online mode

Online Mode enables full use of the instrument with its inputs, outputs and internal programming. In this mode, it is fully interactive with all externally connected elements.

#### Maintenance mode

Maintenance Mode is an off-line mode for maintaining proper and complete functioning of the instrument. Functions include calibration, off-line diagnostic testing, and various setups for operation. In Maintenance Mode, all inputs and outputs are frozen.

### 3.4 Menu Navigation

Moving between the Program, Online, and Maintenance modes of the instrument is done with the Menu, Up Arrow, Down Arrow, and Enter keys located on the front bezel. Refer to Figure 3-1.

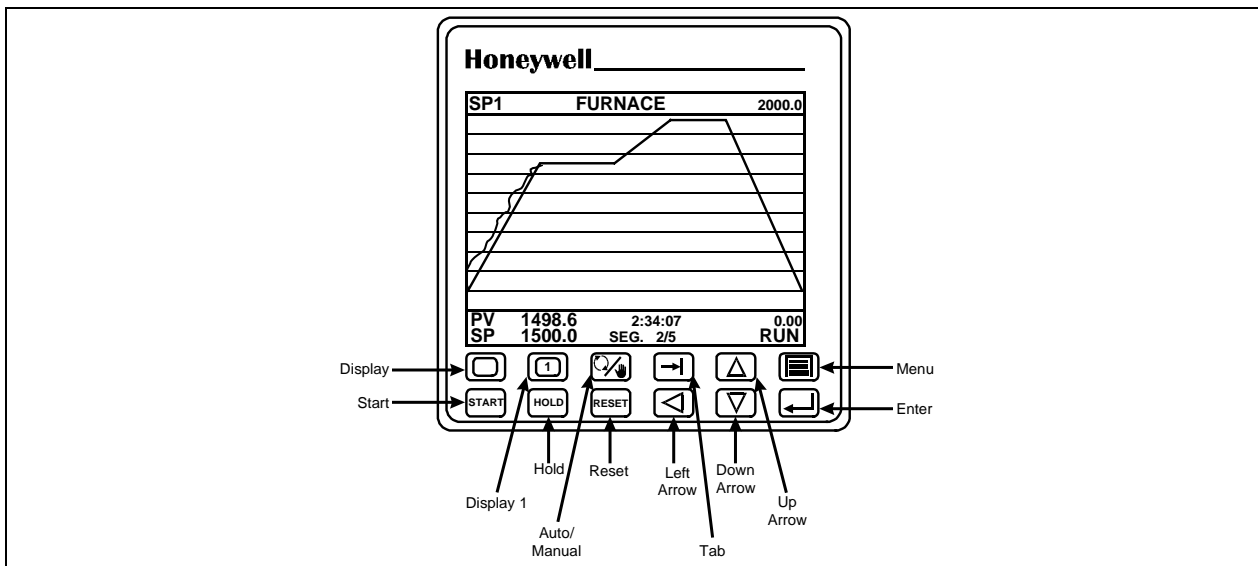


Figure 3-1 VPR100's Front Bezel Buttons

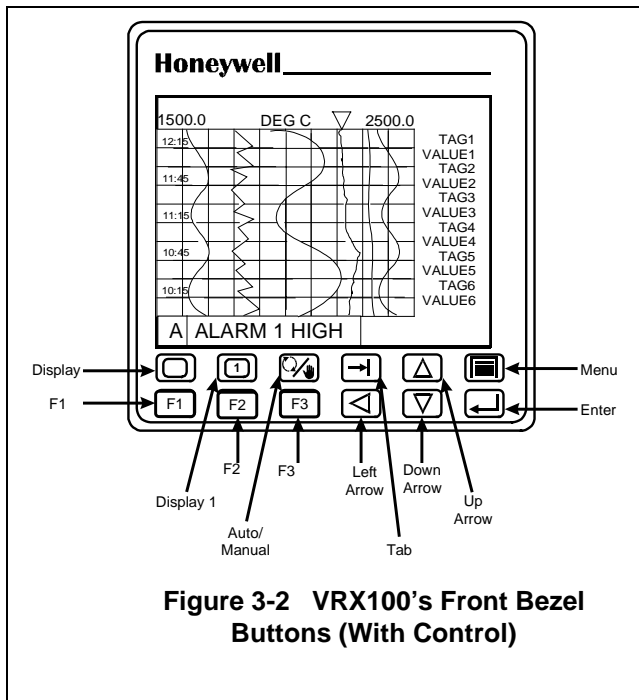


Figure 3-2 VRX100's Front Bezel Buttons (With Control)

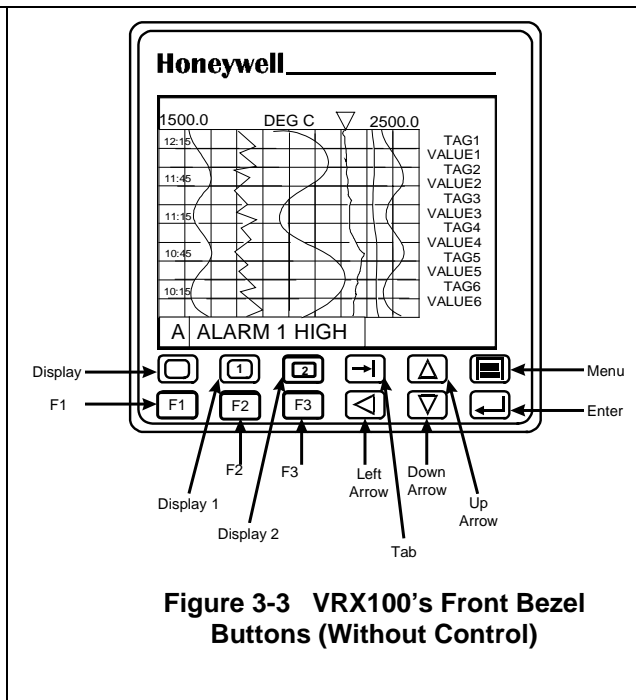


Figure 3-3 VRX100's Front Bezel Buttons (Without Control)



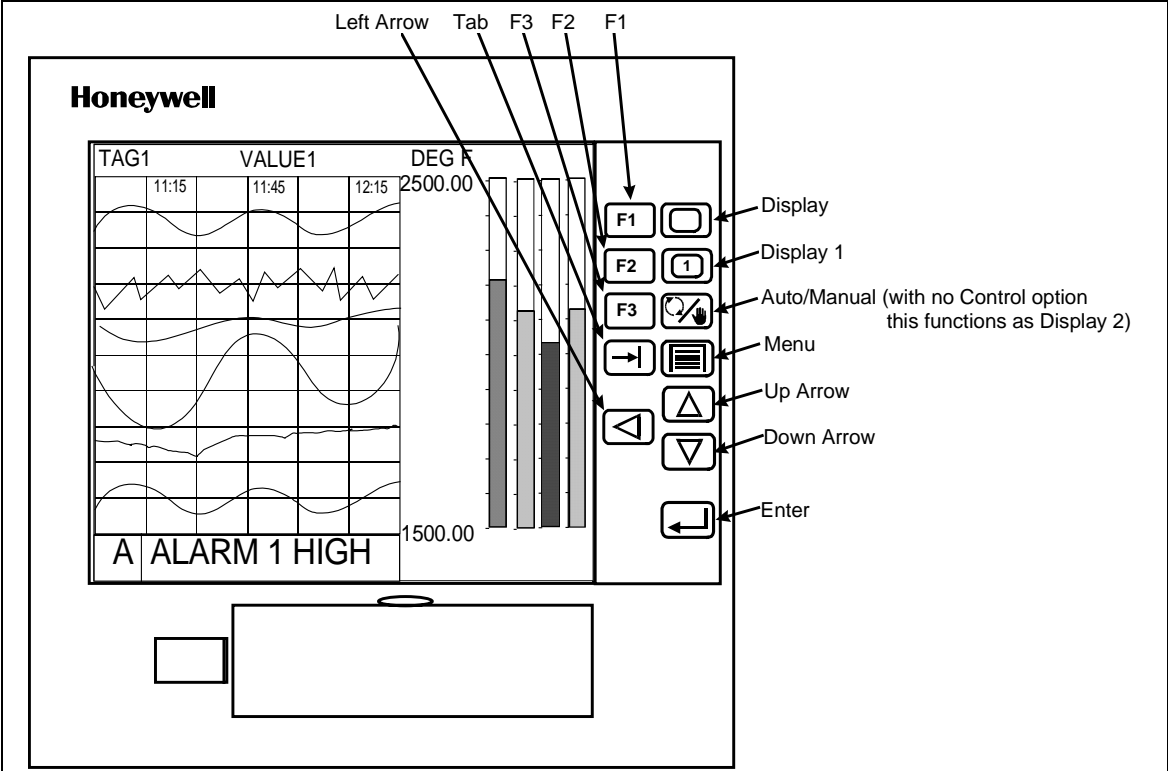


Figure 3-4 VRX150 Front Bezel Buttons

A more detailed explanation of the function of each button appears in Section 3.5.

### Getting familiar with the operating modes

To develop a feel for navigating between modes, power up the instrument and perform steps 1-7 below.

1. When powering up the instrument for the very first time, the logo display will initially appear. Press the Menu button several times until the ON LINE, PROGRAM, or MAINTENANCE mode MAIN MENU is displayed. Refer to Figure 3-5. Note: Menus are shown with all possible options; your menu may not have all options.
2. Once you have established which MAIN MENU you are on, use the Up Arrow and Down Arrow buttons to verify each MAIN MENU choice as indicated in Figure 3-5.
3. Use the Up Arrow and Down Arrow buttons to find and highlight the menu's SET MODE prompt.
4. When the SET MODE prompt is highlighted, press the Enter button.
5. Use the Up Arrow or Down Arrow buttons to switch the instrument to one of the other two instrument modes and press the Enter button.
6. Once within the mode selected in Step 5, scroll through the mode's MAIN MENU using the Up Arrow and Down Arrow buttons. Verify each menu choice as indicated in Figure 3-5.
7. Repeat Steps 3 through 6 for the last of the three mode selections possible.

Having completed the preceding exercise, changing the instrument's mode should now be a simple task. Furthermore, a fundamental understanding of how the Menu, Up Arrow, Down Arrow, and Enter buttons work should now be at your fingertips.

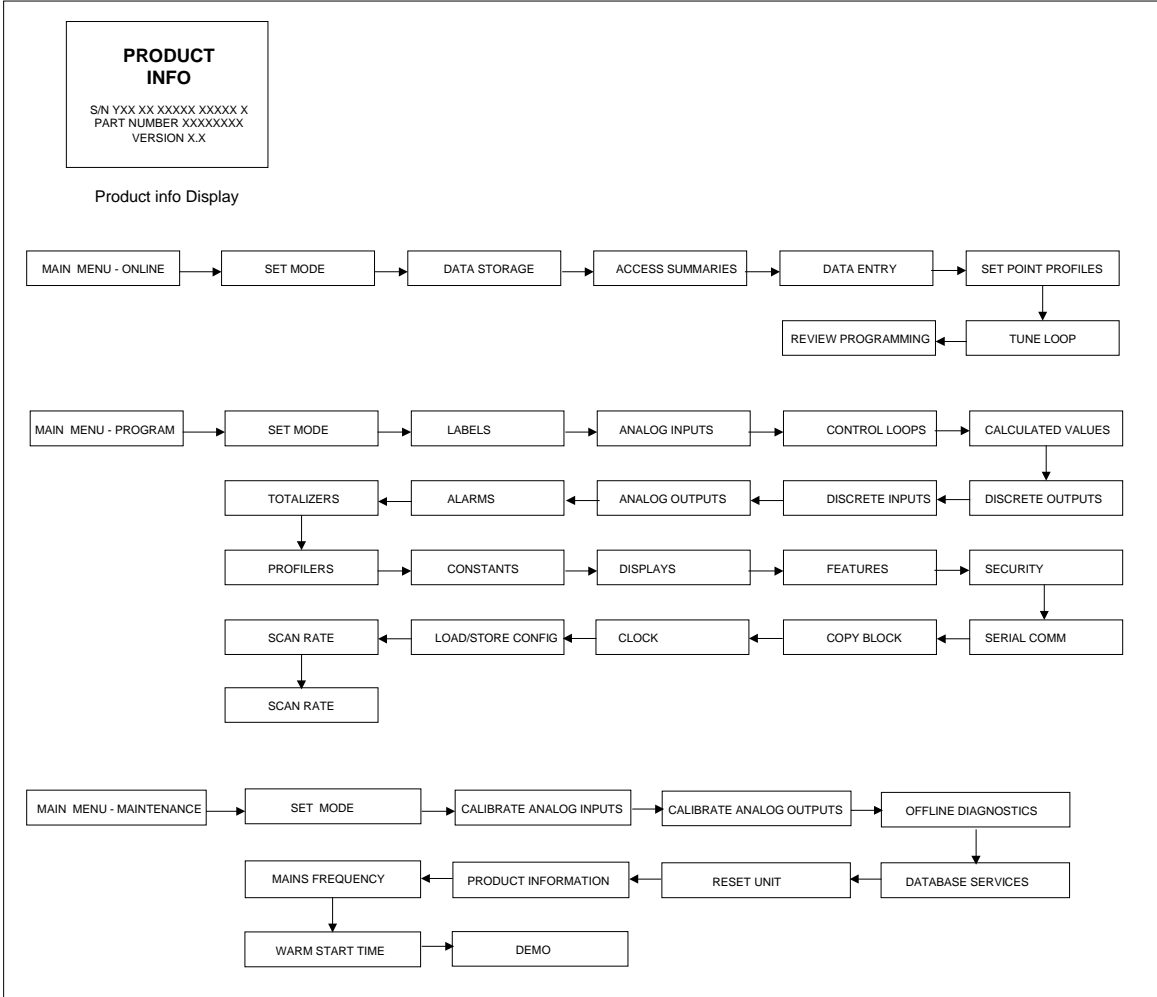


Figure 3-5 Menu Navigation Guide Through ON LINE, PROGRAM, and MAINTENANCE mode MAIN MENUS

### Getting familiar with the menus

Now use the Menu, Up Arrow, Down Arrow, and Enter buttons to verify the ON LINE, PROGRAM, and MAINTENANCE mode sub-level menus detailed in Figure 3-6, Figure 3-7, and Figure 3-8. The sub-level menus shown represent only the first sub-level below each mode's MAIN MENU. There are several sub-level menus, not indicated here, that run further below each first sub-level. Note that once inside of a sub-level menu, regardless of how "deep" the level is, a press of the Menu button will return you to the next highest menu level. In case you get lost within a mode's sub-level menu, keep pressing the Menu button until the ON LINE, PROGRAM, or MAINTENANCE mode MAIN MENU appears on screen.

Be advised that Figure 3-5 through Figure 3-8 comprise a basic "road map" for navigating the menus within the programmer's three modes. Sections 4 through 8 of this manual will provide detailed descriptions of each menu choice and complete guides through all the sub-level menus that run below the levels indicated in these figures.

### ATTENTION

The following menus contain all possible options. Your instrument may not include some items shown here.

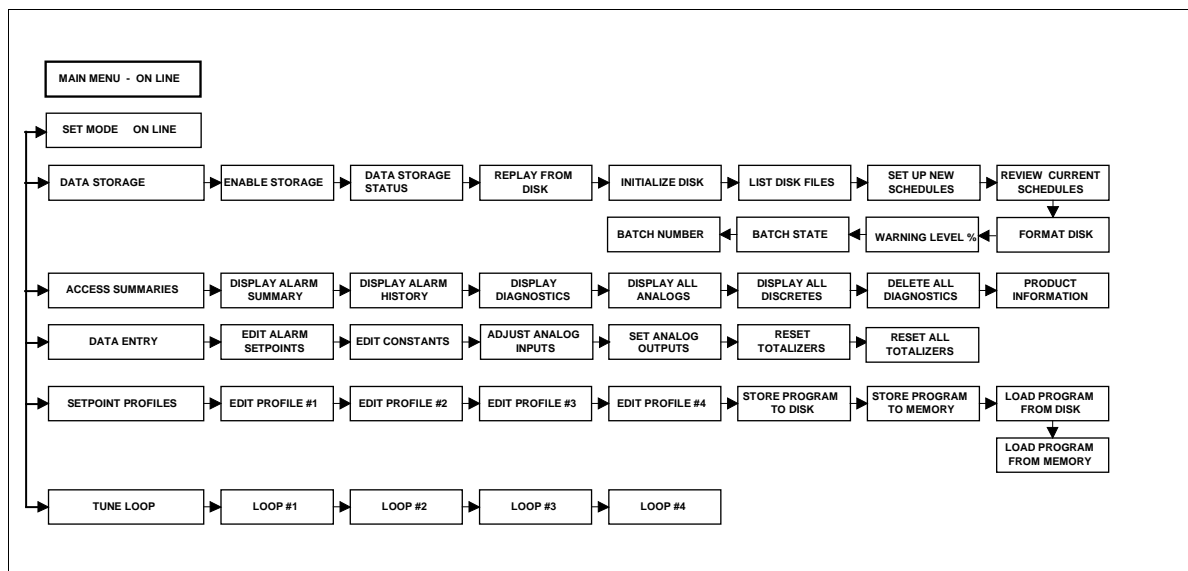


Figure 3-6 ON LINE mode MAIN MENU

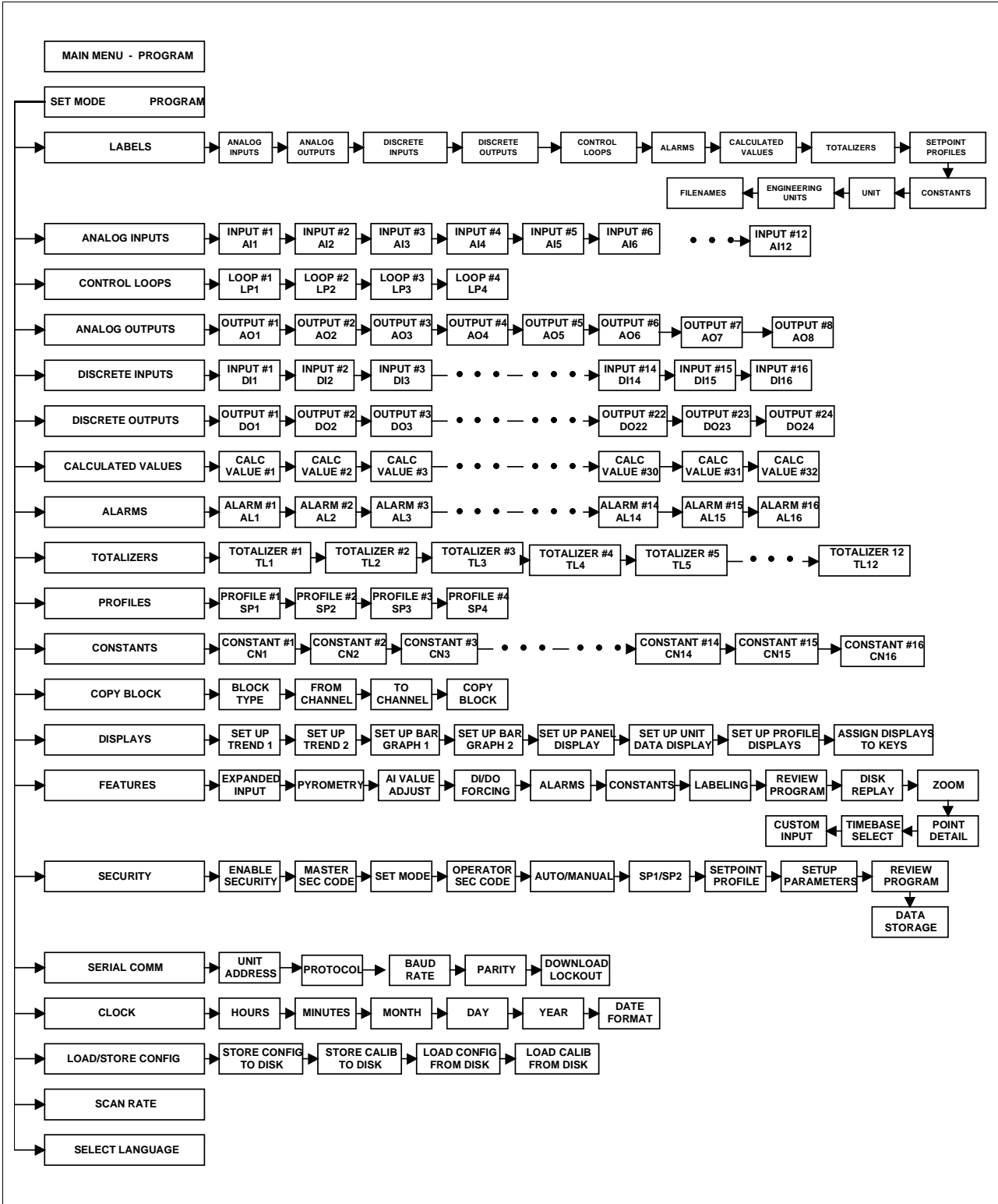


Figure 3-7 PROGRAM mode MAIN MENU

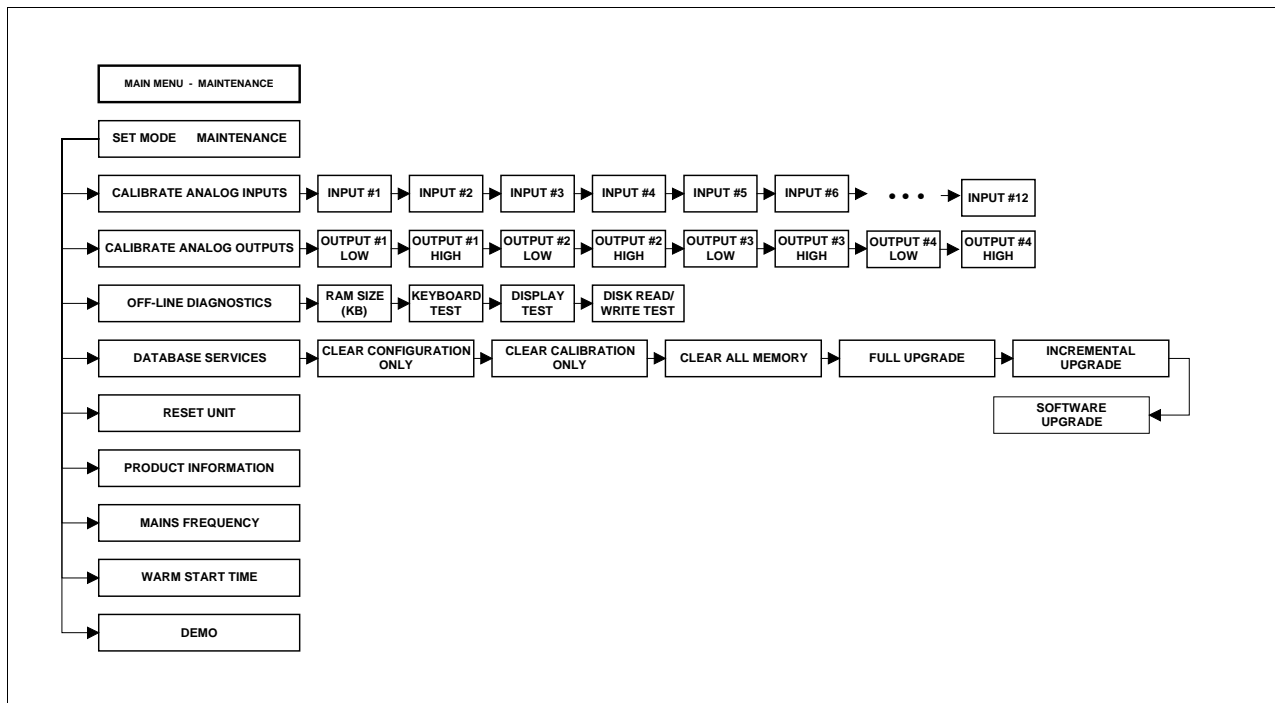




Figure 3-8 MAINTENANCE mode MAIN MENU


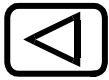
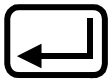
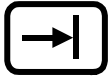
### 3.5 Button functions

In all modes, use the front panel buttons to view and select items from menus and displays. Table 3-1 describes each panel button and its functions.

**Table 3-1 Button Functions**




Symbol	Name	Function	Operating mode in which function applies		
			Program	Online	Maint
	Menu	<ul style="list-style-type: none"> <li>• Accesses Online Mode Menu from online primary display.</li> <li>• Backs cursor out of a menu to next higher menu level. Use when finished looking at or changing menu items.</li> <li>• If changes were made and you are prompted to PRESS ENTER TO SAVE, press to exit menu without saving changes.</li> </ul>		✓	
	Up Arrow/ Previous	<ul style="list-style-type: none"> <li>• Moves cursor up a menu or list of choices.</li> <li>• Immediately after selecting a menu item to change, repeatedly scrolls through NONE or OFF, PARM(parameters), 0-9 (of most significant digit of a number), minus sign (-). Once you move the cursor off a number's most significant digit, then only 0-9 are choices. You can change a number to a parameter, NONE, or OFF only while the cursor is initially on the most significant digit.</li> <li>• When selecting most significant digit of a number, scrolls through 0-9, minus sign, and OFF or NONE (if available). For other digits, scrolls through 0-9.</li> <li>• When entering a label such as a DESCRIPTOR or TAG, scrolls through A-Z, 0-9, period (.), hyphen (-), slash (/), plus (+), asterisk (*), blank ( ).</li> <li>• In loop display, increases loop's setpoint value (loop must be in Auto mode).</li> <li>• In loop display, increases loop's output (loop must be in Manual mode).</li> <li>• Scrolls a trend forward in time.</li> </ul>	✓	✓	✓

**Table 3-1 Button functions (continued)**





Symbol	Name	Function	Operating mode in which function applies		
			Program	Online	Maint
	Down Arrow/ Next	<ul style="list-style-type: none"> <li>Moves cursor down a list/menu.</li> <li>When selecting a number, letter, or decimal point position, moves cursor one character to the right, then wraps around to leftmost character.</li> <li>In loop display, decreases loop's setpoint value.</li> <li>In loop display, decreases loop's output (loop must be in Manual mode).</li> <li>Scrolls a trend backward in time.</li> </ul>	<p>✓</p> <p>✓</p>	<p>✓</p> <p>✓</p> <p>✓</p>	<p>✓</p> <p>✓</p>
	Left Arrow	<ul style="list-style-type: none"> <li>Numeric entry: moves one digit to left.</li> <li>Text entry: moves one character to right.</li> </ul>	<p>✓</p>	<p>✓</p>	<p>✓</p>
	Enter	<ul style="list-style-type: none"> <li>Selects displayed menu item and either displays its submenu or moves cursor to the right for data entry.</li> <li>Enters a changed value or parameter.</li> <li>If prompted to SAVE CHANGES?, saves changes made and returns to higher menu.</li> </ul>	<p>✓</p> <p>✓</p> <p>✓</p>	<p>✓</p> <p>✓</p> <p>✓</p>	<p>✓</p> <p>✓</p>
	Tab	<ul style="list-style-type: none"> <li>When trend or panel display is on, accesses Trend menu or panel display menu to adjust the appearance of the display.</li> <li>When either above menu is shown, advances display to next live point.</li> <li>When Setpoint Profile Trend display is shown, accesses a menu for viewing and controlling operation of the profile.</li> <li>On Loop displays, tabs cursor to next loop data field for adjustment.</li> </ul>		<p>✓</p> <p>✓</p> <p>✓</p> <p>✓</p>	



**Table 3-1 Button functions** (continued)

Symbol	Name	Function	Operating mode in which function applies		
			Program	Online	Maint
	Display	<p><i>For instruments with the control option:</i></p> <p>From any display or menu, pressing this button changes the instrument to online mode* and accesses the display programmed as Display #2. Repeated presses accesses displays #3 through #10, then wraps around to display #2 again.</p> <p><i>For instruments without the control option:</i></p> <p>From any display or menu, pressing this button changes the instrument to online mode* and accesses the display programmed as Display #3. Repeated presses accesses displays #4 through #10, then wraps around to display #3 again.</p> <p>See Table 4-63 on page 161 for more information on the Displays.</p>	✓  ✓	✓  ✓	✓  ✓
	Display 1	<p>From any display or menu, pressing this button changes the instrument to online mode* and accesses the display programmed as Display #1.</p> <p>See Table 4-63 on page 161 for more information on Displays.</p>	✓	✓	✓
	Display 2	<p>This button is only available on non-control instruments.</p> <p>From any display or menu, pressing this button changes the instrument to online mode* and accesses the display programmed as Display #2.</p> <p>See Table 4-63 on page 161 for more information on Displays.</p>	✓	✓	✓
<p>* Note: Changing to ONLINE mode by pressing any of the Display buttons can cause incorrect values to be displayed. The values will correct themselves in a few seconds. To avoid this potential annoyance, first change to online mode by selecting SET MODE from the PROGRAM or MAINTENANCE menus, then press a Display button to access the displays.</p>					

**Table 3-1 Button functions** (continued)

Symbol	Name	Function	Operating mode in which function applies		
			Program	Online	Maint
	Auto/Manual	<ul style="list-style-type: none"> <li>This key is available only on instruments with control.</li> <li>On VRX150 without control, this key functions as the Display 2 key.</li> <li>In a loop display, toggles loop between Auto and Manual modes (loop's Force Remote Manual discrete must be OFF).</li> <li>In a loop display, toggles loop between Remote Manual and Manual modes (loop's Remote Manual discrete must be ON).</li> <li>Does not function if loop's Discrete vs. Key discrete is ON. In this case, the button's functioning has been transferred to the loop's Auto/Manual Select discrete.</li> </ul>		<p>✓</p> <p>✓</p> <p>✓</p>	
<b>ATTENTION</b>					
The following keys are like Digital Inputs on the keypad of the instrument. They must be configured as part of the instrument's function blocks in order to be active.					
	START	<p>This key is on the VPR100 only.</p> <ul style="list-style-type: none"> <li>When pressed this key raises the SY1 F1 signal for 1 machine scan cycle.</li> <li>User typically programs it to Profiler Start input.</li> </ul>		✓	
	HOLD	<p>This key is on the VPR100 only.</p> <ul style="list-style-type: none"> <li>When pressed this key raises the SY1 F2 signal for 1 machine scan cycle.</li> <li>User typically programs it to Profiler Hold input (Use Edge/Level input selection).</li> </ul>		✓	
	RESET	<p>This key is on the VPR100 only.</p> <ul style="list-style-type: none"> <li>When pressed this key raises the SY1 F3 signal for 1 machine scan cycle.</li> <li>User typically programs it to Profiler Reset input.</li> </ul>		✓	

**Table 3-1 Button functions** (continued)

Symbol	Name	Function	Operating mode in which function applies		
			Program	Online	Maint
<b>F1</b>	F1	<p>This key is on the VRX100/150 only.</p> <ul style="list-style-type: none"> <li>When pressed this key raises the SY1 F1 signal for 1 machine scan cycle.</li> <li>For instruments with the Setpoint Profiler, user typically programs it to Profiler Start input or Totalizer Reset.</li> </ul>		✓	
<b>F2</b>	F2	<p>This key is on the VRX100/150 only.</p> <ul style="list-style-type: none"> <li>When pressed this key raises the SY1 F2 signal for 1 machine scan cycle.</li> <li>For instruments with the Setpoint Profiler option, user typically programs it to Profiler Hold input (Use Edge/Level input selection) or to Totalizer Reset.</li> </ul>		✓	
<b>F3</b>	F3	<p>This key is on the VRX100/150 only.</p> <ul style="list-style-type: none"> <li>When pressed this key raises the SY1 F3 signal for 1 machine scan cycle.</li> <li>For instruments with the Setpoint Profiler option, user typically programs it to Profiler Reset input or Totalizer Reset.</li> </ul>		✓	










### 3.6 Text Entry From External Sources

#### QWERTY keyboard

To use a keyboard to enter text such as labels, numbers, and equations, connect an AT Qwerty keyboard to the mini DIN connector with an adapter (part No. 104286). See section 3.7 on how to open the front bezel to access the mini DIN connector. See Table 3-2 for key functions.




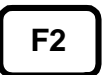

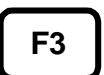
The instrument’s cursor must on the text to be changed (on the right side of the display) before you type in the new text. Press Enter to accept the changes or press Menu to reject the changes.

**Table 3-2 QWERTY Key Equivalents**

Button	Name	QWERTY key	Function
	Menu	ESC	<ul style="list-style-type: none"> <li>Exits prompt or menu without saving changes.</li> <li>Changes from online display to online menu.</li> </ul>
	Up Arrow/Previous	↑	<ul style="list-style-type: none"> <li>Scrolls up a menu or list</li> </ul>
	Down Arrow/Next	↓	<ul style="list-style-type: none"> <li>Scrolls down a menu or list</li> </ul>
	Left Arrow	←	<ul style="list-style-type: none"> <li>Increments the value of the selected field.</li> </ul>
	Enter	Enter ↵	<ul style="list-style-type: none"> <li>Selects menu item to change it.</li> <li>Saves changes made.</li> </ul>
	Display	F4	<ul style="list-style-type: none"> <li>Changes to online mode and shows online displays.</li> <li>Exits Point/Details menu.</li> </ul>
	Display 1	F3	Accesses Display #1.
	Auto/Manual	F2	<ul style="list-style-type: none"> <li>Toggles Loop between Automatic and Manual.</li> <li>On VRX150 without control, accesses Display #2.</li> </ul>
	Tab	F1	<ul style="list-style-type: none"> <li>Moves cursor around displays.</li> <li>Accesses Point/Details menu.</li> </ul>

*Continued*

**Table 3-2 QWERTY Key Equivalents (continued)**

Button	Name	QWERTY key	Function
  or	Start or F1	F5	Initiates a discrete action programmed to this key, such as Starting a Setpoint Profile or resetting a totalizer.
  or	Hold or F2	F6	Initiates a discrete action programmed to this key, such as Holding a Setpoint Profile or resetting a totalizer.
  or	Reset or F3	F7	Initiates a discrete action programmed to this key, such as Resetting a Setpoint Profile or resetting a totalizer.

**ASCII barcode reader**

To enter text such as labels, numbers, and equations with a barcode reader, connect the barcode reader to the min DIN connector with an adapter (part No. 104286). The instrument buttons remain functional. See section 3.7 on how to open the front bezel to access the mini DIN connector.

To enter labels, the instrument’s cursor must be on the text to be changed (on the right side of the display) before you scan in the new text from the barcode. Press Enter to accept the changes, or press Menu to reject the changes.

The barcode reader may also be used on the instrument trend screens to enter text data that will be stored as a time stamped event. The ASCII data is split up into three fields:

- Description            16 characters
- Tag                      7 characters
- State                    6 characters

The first 16 characters will go into the description field. The next 7 into the tag field and so on.

This data will be time stamped and stored in the event file (.LNE) on the disk.

***Barcode Reader Recommendation***

- The barcode reader should output ASCII keyboard data.
- The reader should be capable of Code 39 barcode input
- The connector should be able to connect to the Keyboard connector located under the bezel.

**CAUTION**

While the barcode reader is installed, data storage is to a buffer, **NOT** disk.

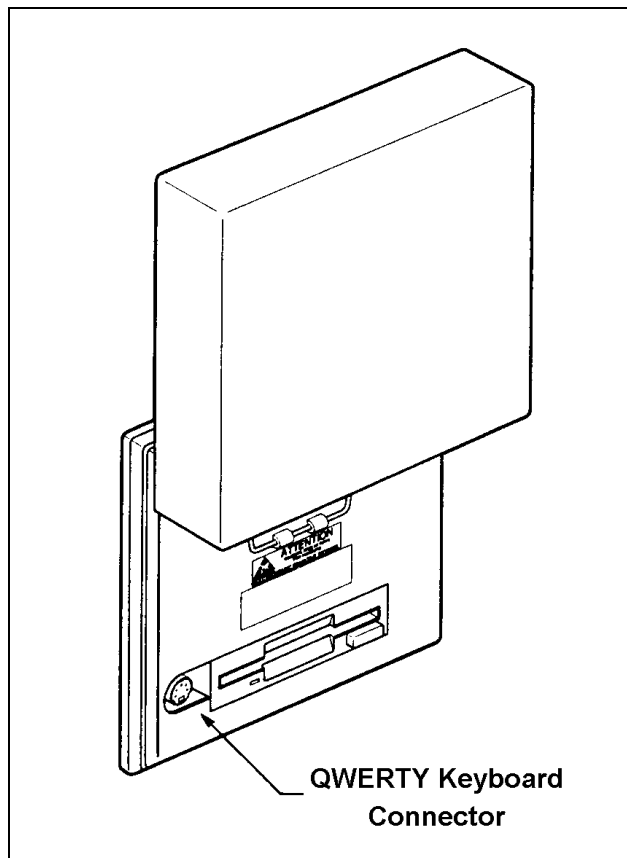
### 3.7 Access to Floppy Drive, Keyboard/Barcode Reader Connection

#### VPR100 & VRX100 Access

To connect a QWERTY keyboard or barcode reader, to remove or install a floppy disk, or to access the inside of the instrument, open the front bezel as described in Table 3-3.

**Table 3-3 Front Bezel Open/Close Procedure**

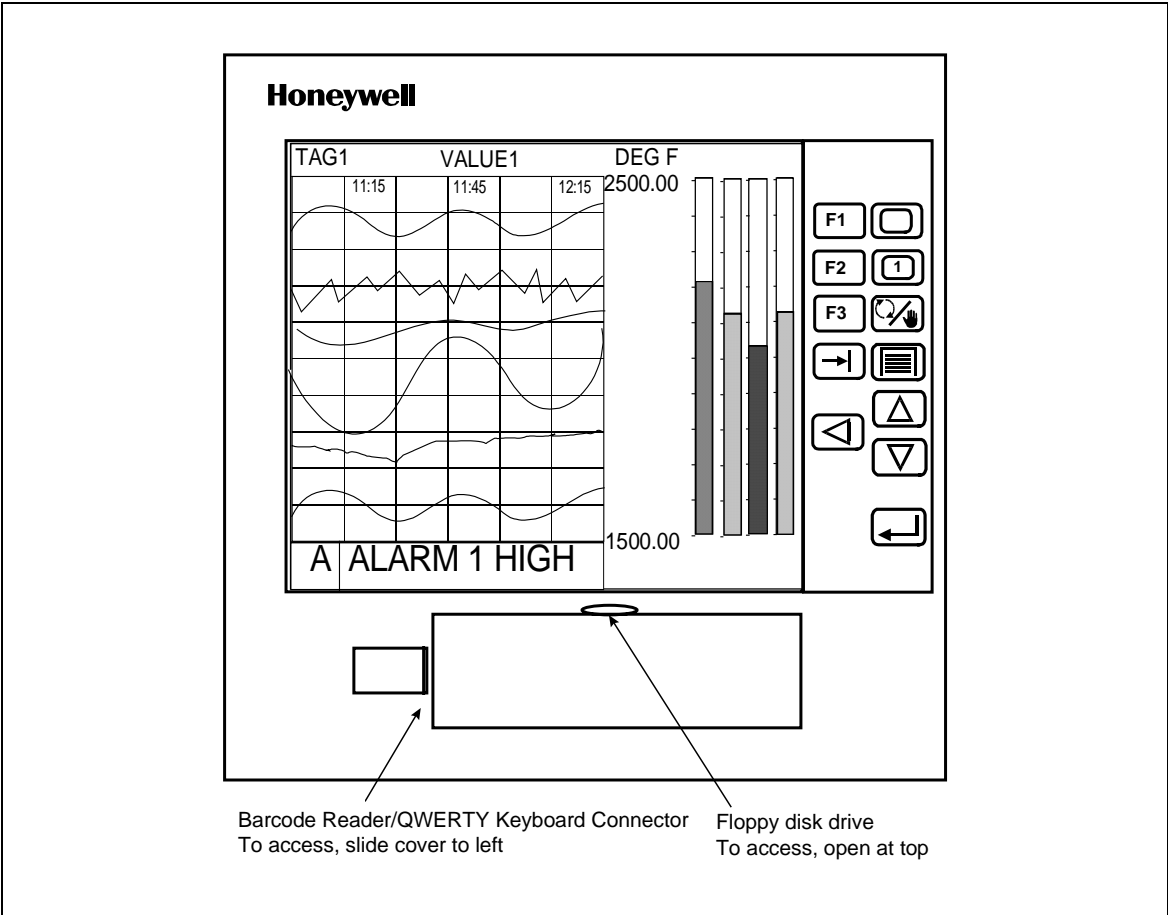
Step	Action
1	While pressing the bottom of the bezel inward, press the button on the underside of the bezel to release the latch.
2	Pull the bottom of the bezel outwards slightly away from the panel and then lift it gently to fully open it as shown in Figure 3-9.
3	Close the bezel by releasing the bezel release lever and lowering the bezel with the bottom held slightly out. Engage the top edge of the bezel first and then swing the bottom inward toward the panel. Press the bottom in firmly until the latch clicks into place. Close the bezel securely or storage to disk will not operate properly.



**Figure 3-9 Access to Connector and Floppy Drive (VPR100 & VRX100)**

**VRX150 Access**

To access the floppy disk drive or the keyboard connector on the VRX150, see Figure 3-10.



**Figure 3-10 Access To Connector and Floppy Drive (VRX150)**

## 3.8 Definition of Function Blocks

### Definition

A *function block* is a unit of software that performs a set of operations on its *input parameters* and *function block parameters* and produces *output parameters*. These output parameters can be programmed as inputs to other function blocks, whose output parameters can be programmed as inputs to other function blocks, and so on. By programming all desired function blocks' input parameters and function block parameters, you configure the instrument to measure and control your process.

### Types of function blocks

Each function block performs a set of operations which fulfills a unique purpose. For example, the Analog Input function blocks processes the analog input data, the alarm function block processes alarms, and so on.

Table 3-4 describes each function block.

Some function blocks—namely, Analog Input, Analog Output, Discrete Input, and Discrete Output—interface with the hardware; that is, they are the link between the instrument and the input or output hardware. The Analog Input and Discrete Input function blocks convert the incoming process data (like the process variable or any discrete on/off signals from a switch) into information usable by the instrument. This incoming information is processed according to the entire function block configuration in the instrument, and it is ultimately passed on to the output function blocks. The Analog Output and Discrete Output function blocks convert this output information into a voltage or current which is fed to the corresponding output hardware (like a current output or relay).

Other function blocks are not directly “seen” by the hardware; they are purely software. They can be thought of as the middle of the process described in the previous paragraph. For example, a Standard Splitter Calculated Value can split a control loop's output into 2 values: one for heating and one for cooling. These 2 values can be passed on to the Analog Output function block which ultimately controls the amount of output current or voltage.

### Flow of information

The “flow” of information— from the input hardware to the input function blocks to the function block configuration to the output function blocks to the output hardware—can be likened to a river flowing from upstream to downstream. In some cases, like with a control loop's feedback, this analogy is not true because the information is flowing in a circle, but it is a helpful way to view how function blocks are generally interconnected. For example, the Analog Input function block is typically upstream of the Control Loop function, which is typically upstream of the Analog Output function block. Of course, if two function blocks are not directly or indirectly connected, there is no flow between the two. Just remember that every function block has input, does a set of operations, and produces an output. When several function blocks are linked together, there is a flow of information.



**Table 3-4 Function Block Types**

Function block name	Type	VRX100 Maximum available	VRX150 Maximum available*	VPR100 Maximum available*	Purpose
Alarm	AL	16	16	16	Causes alarms under specified conditions.
Analog Input	AI	12	12	12	Interfaces with measuring input hardware (thermocouple, RTD, mA, volts).
Analog Output	AO	8	8	8	Interfaces with analog output hardware (current output (CAT) or voltage output (VAT)) or with output relay hardware (time proportion (DAT), Position Proportion (POS PROP)). Up to 3 current/voltage outputs.
Calculated Value	CV	32	32	32	Performs various calculations on specified parameters.
Constant	CN	16	16	16	Outputs a number or an analog parameter value.
Discrete Input	DI	16	16	16	Interfaces with discrete input hardware (dry contact closure).
Discrete Output	DO	16	24	24	Interfaces with output relay hardware (AC relay, DC relay, mechanical relay, open collector output).
Loop	LP	2	4	4	PID or ON/OFF control with various outputs.
Setpoint Profiler	SP	1	4	4	Generates a time-varying setpoint for a loop's <b>Setpoint #2</b> .
System	SY	1	1	1	Outputs discrete status of alarms, data storage, and diagnostics; outputs analog value of reference junction temperature. This function block is not programmable; its outputs are produced automatically.
Totalizer	TL	12	12	3	Outputs accumulated total over time.

\* Depends on options ordered.

**Why use function blocks?**

Function blocks give you configuration flexibility. For instance, the instrument does not have a dedicated relay that is activated during an alarm; instead, you can program any of several Alarm function blocks to control any relay. Also, there is not a specific input for your process variable; any of several Analog Input function blocks can be programmed to be your process variable. In general, function blocks let you connect the output parameter of any function block to the input parameter of any function block.

### 3.9 Components of function blocks

The three components of a function block are:

- Input parameter(s)
- Function block parameter(s)
- Output parameter(s).

Figure 3-11 shows the function block Alarm #1's components.

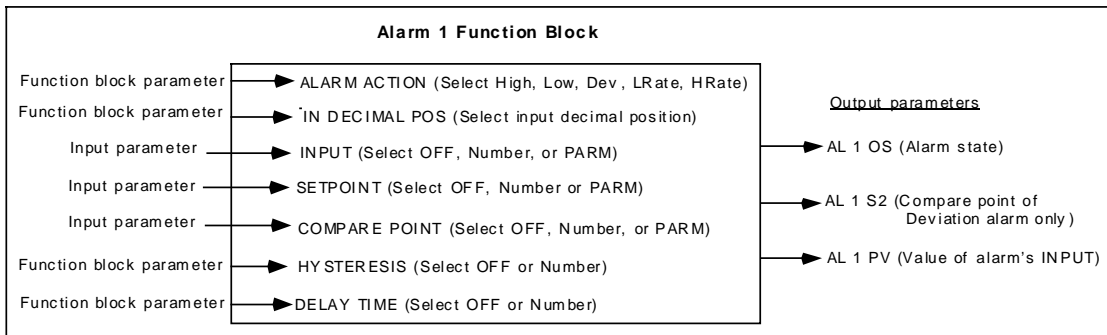


Figure 3-11 Alarm 1 Function Block Components

#### Input parameter

A function block's input parameter can be configured to be OFF, a number, or it can receive its data from outside the block from another block's output codes. These output codes are shown in Table 3-5. That is, an input parameter is any menu item that can be programmed as (connected to) one of these output codes. These output codes are grouped under the menu choice PARM. When you are programming a function block and one of your choices is PARM, you know you are programming an input parameter. See Figure 3-11.

For example, suppose you are programming an alarm function block. One of the alarm's menu items is INPUT, which specifies which point will be monitored for an alarm condition. One of the choices for the INPUT is PARM, which lets you connect the INPUT to one of the output codes in Table 3-5. Therefore, the INPUT is an input parameter because it receives its data from another function block.

Some function blocks can have multiple input parameters. For example, an Alarm function block has an INPUT and a SETPOINT, both of which can be connected to other function blocks.

Discrete Input function blocks have no input parameters; that is, they have no inputs that can be connected to another block's output codes.

### Function block parameter

A function block parameter's data is contained within the block. When you are programming a function block and are not given a choice of PARM, you are programming a function block parameter. Typical choices when programming a function block parameter are NONE, OFF, any numerical value, or a list of options for the parameter, but not PARM. See Figure 3-11.

For example, to program an Alarm function block's ALARM ACTION, you select from a list of choices: NONE, LOW, HIGH, DEV, LRATE, HRATE.

Other function block parameters are an Analog Input's RANGE LOW and RANGE HIGH, where you specify the voltage range or temperature range.

### Output code

An output code is the result of the function block's operations on the input parameters and function block parameters. It is designated by one of the two-character output codes shown in Table 3-5. An output code can be programmed to be the input to one or several other function blocks. See Figure 3-11.

Output codes are either discrete (can be on or off) or analog (numerical value). For example, DI1 OS is the output status of Discrete Input #1: on or off. AI1 OV is the output value of Analog Input #1: a voltage or temperature. Therefore, a discrete input parameter must be programmed with only a discrete output code, and an analog input parameter must be programmed with only an analog output code.

---

### ATTENTION

The function block SYSTEM PARAMETER, abbreviated SY, does not have input parameters or function block parameters like the other function blocks; SY produces output codes only. These output codes, shown in Table 3-5, are mostly values or states that indicate the status of system-wide parameters. For example, if any Alarm function block's output status is ON, the SY function block's AG (alarm global) output code is also ON.

Another example is the SY F1 output code, which produces a quick ON-to-OFF discrete signal when the F1 or START key is pressed. This SY F1 can be used as a trigger to another action. **For example, to allow an operator to start the Profile or reset the Totalizer by pressing the START key or F1 key, you can program a Setpoint Profile's Start parameter or a Totalizer's Reset parameter with SY F1.**

---

**Table 3-5 Function Block Parameter Designators**

Function Block Type	Function Block Name	Output code	Parameter Name	Parameter Type
AI	Analog Input	OV	Output Value	Analog
SY	System Parameter	RT	Reference Junction Temp.	Analog
		BN	Batch number of data storage	Analog
		PN	Currently running program number	Analog
		AG	Alarm Global	Discrete
		AH	Alarm High	Discrete
		AL	Alarm Low	Discrete
		DF	Diagnostic failure	Discrete
		DG	Diagnostic General	Discrete
		SF	Storage Full	Discrete
		SW	Storage Warning	Discrete
		AX	Analog Safe Parameter	Analog
		DX	Discrete Safe Parameter	Discrete
		F1	F1 or Start Key on keyboard	Discrete
		F2	F2 or Hold Key on keyboard	Discrete
F3	F3 or Reset Key on keyboard	Discrete		
AO	Analog Output	OV	Output Value	Analog
		BC	Back Calculation Value (Feedback)	Analog
		S2	Process Variable (AO's input)	Analog
DI	Discrete Input	OS	Output State	Discrete
DO	Discrete Output	OS	Output State	Discrete
LP	Control Loop	OV	Output Value	Analog
		PV	Process Variable	Analog
		DV	Deviation Value	Analog
		WS	Working Setpoint	Analog
		S1	Setpoint #1 Value	Analog
		S2	Setpoint #2 Value	Analog
		BC	Back Calculation Value (Cascade feedback)	Analog
		AM	Auto/Manual Status	Discrete
		SS	Setpoint #1/Setpoint #2 Status	Discrete
		ON/OFF Loop only	OS	Output Status

**Table 3-5 Function Block Parameter Designators (continued)**

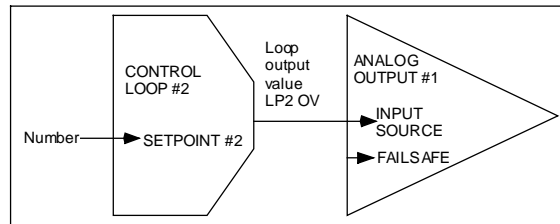
Function Block Type	Function Block Name	Output code	Parameter Name	Parameter Type
SP	Setpoint Profiler	OV	Output Value	Analog
		A1	Auxiliary Output Value	Analog
		PV	Process Variable (Guaranteed Soak PV #1)	Analog
		SN	Segment Number	Analog
		SH	Hold Status	Discrete
		SE	End Status	Discrete
		SA	Active Status	Discrete
		SI	Active or Hold Status	Discrete
		SR	Ready Status	Discrete
		E1	Event#1 Output	Discrete
		thru	thru	
		E9	Event#9 Output	
		EA	Event#10 Output	↓
		EB	Event#11 Output	
thru	thru			
EG	Event#16 Output	Discrete		
AL	Alarm	PV	Process Variable (alarm's input)	Analog
		S2	Compare Point (of Deviation alarm)	Analog
		OS	Output Status	Discrete
CN	Constant	OV	Output Value	Analog
		PV	Process Variable (Constant's input)	Analog
CV	Calculated Value*	OV	Output Value	Analog
		PV**	Process Variable	Analog
		A(n)	Analog Output #n	Analog
		BC	Back Calculation	Analog
		S2	Auxiliary input (link to totalizer preset)	Analog
		D(n)	Discrete Output	Discrete
OS	Output Status	Discrete		
<p>*CV output codes are available for programming only if the CV has been programmed. For example, you cannot program an input parameter with CV1 OV unless CV1 has been programmed.</p> <p>**Input to the following CV types: Peak Pick, 1 Point Block Avg., 1 Point Rolling Avg., Scaling, Signal Select</p>				
TL	Totalizer	OV	Output Value	Analog
		PV	Process Variable (Totalizer's input)	Analog
		OS	Output Status	Discrete
		S2	Preset Value	Analog

### 3.10 How to program input parameters

A function block has two types of programmable parameters: input parameters and function block parameters. When in a function block's Program menu, if a menu item has choices OFF, a number, or PARM, then the menu item is an input parameter to that function block. That is, if you choose PARM you can connect the input parameter to another function block's output code.

#### How to connect an input parameter to another function block

One way to program an input parameter is to connect it to an output parameter from another function block. We will show you this procedure using a specific function block's input parameter, but the keystrokes used in the procedure will apply when you are making any input parameter connection.

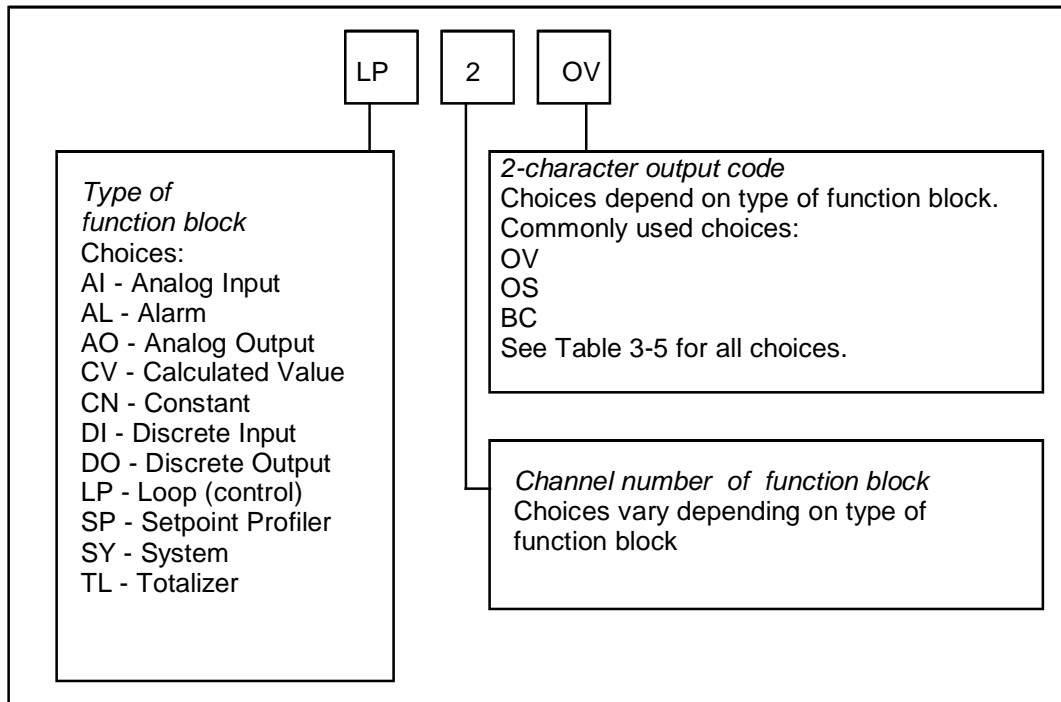


**Figure 3-12 Example Input Parameter Connection**

Assume we want to make the connections shown in Figure 3-12. We want Analog Output#1, a current output, to get its input from Control Loop#2's output value. Therefore, we must program Analog Output#1's Input Source parameter with the output code that represents Control Loop#2's output value. The following procedure shows how.

**Table 3-6 Output Code Connection Procedure**

Step	Action
1	In the Program Analog Output menu, select ANALOG OUTPUT#1.
2	Consult the Program Analog Output section of this manual to learn about the menu item you wish to change, namely, INPUT SOURCE.
3	Press Down Arrow button to move the cursor to the menu choice INPUT SOURCE.
4	Press Enter to move the cursor to the right side of the display where the choices for INPUT SOURCE are.
5	Press Up Arrow until PARM is displayed. If you press too many times and a number is displayed, continue pressing Up Arrow until PARM is displayed again. If you press Down Arrow while the number is displayed, the instrument assumes you want to enter a number, not a parameter. If you pressed Down Arrow, you must press Menu, then press Enter, then Up Arrow until PARM is displayed.
6	Press Enter to select PARM, which gives you choices for output codes to connect to. Figure 3-13 shows the format for all output codes.
7	Press Up Arrow or Down Arrow until LP is displayed. From Table 3-5, we know LP is the designator for the Control Loop function block type.
8	Press Enter to select LP.
9	Press Up Arrow or Down Arrow until 2, the Control Loop number we want, is displayed.
10	Press Enter to select 2.
11	Press Up Arrow or Down Arrow until OV is displayed. From Table 3-5 we know OV is the output code for the Control Loop's output value.
12	Press Enter to select OV. The cursor moves to the left and the connection from LP2 OV to Analog Output#1's INPUT SOURCE has been made.



**Figure 3-13 Function Block Connection Format**

Before programming a function block's input parameter with a CV's (Calculated Value) output code, you must program the CV first. Otherwise, the CV's output parameter will not be available for programming.

The function block SY (System Parameter) operates internally and cannot be programmed. It automatically produces outputs which reflect the status of alarms, data storage, diagnostics, and reference junction temperature. These outputs can be used as inputs to function blocks.

**How to program an input parameter with a number**

Besides connecting an input parameter to another function block, you can program an input parameter with a number. The instrument will accept -999,999 to 9,999,999.

Continuing with the previous example, assume we want Loop #2's Setpoint #2 to be a number. Therefore, we must program Loop #2's Setpoint #2 parameter with a number, say 95. The following procedure shows how.

**Table 3-7 Example Number Selection Procedure Using Front Panel Buttons**

Step	Action
1	In the Control Loops menu, select LOOP #2.
2	Consult the Program Control Loops section of this manual to learn about the menu item you wish to change, namely, SETPOINT #2.
3	Press Down Arrow button to move the cursor to the menu choice SETPOINT #2.
4	Press Enter to move the cursor to the right side of the display where the choices for SETPOINT #2 are.
5	Press Up Arrow until NUMBER is displayed. Press Enter.
6	The rightmost digit will slowly flash on and off, indicating the cursor position. Since we want to change the number to 95.00, press the Left Arrow until the ones digit flashes. The Left Arrow moves the cursor to the left.
7	Press Up Arrow to change the 0 to a 5.
8	To change the tens digit, press Left Arrow to move the cursor one place to the left.
9	To change the 0 to a 9, press Up Arrow nine times.
10	At this point, 95.00 should be displayed with the 9 flashing. Since 95.00 is the value we want, press Enter to select it. The cursor moves left to the SETPOINT #2 prompt and the value is selected.

**ATTENTION**

To enter a number with a connected keyboard, instead of steps 5-10 simply type in the number 95 and press Enter.

**How to program a discrete input parameter with a number**

Table 3-7 shows how to connect Setpoint #2, an analog parameter, to a number. You can also connect a discrete parameter to a number. A discrete parameter, such as an alarm’s input source, can be connected to any discrete parameter type in Table 3-5, or it can be programmed with a 0 to signify the off state or with a 1 to signify the on state. Enter a value of 1 or 0. For example, if you program an alarm’s input source (Figure 3-11) with a value of 1, the alarm’s output (AL1 OS) will always be on.

To program a discrete parameter with a 1 or 0, perform the following procedure. The procedure uses Alarm1’s Input source as the parameter being programmed.

**Table 3-8 Example Programming Discrete Input Parameter with a Number**

Step	Action
1	In the Program Alarms menu, select ALARM #1.
2	Consult the Program Alarm section of this manual to learn about the menu item you wish to change, namely, INPUT SOURCE.
3	Press Down Arrow to move the cursor to INPUT SOURCE.
4	Press ENTER to move the cursor to the right side of the display where the choices for INPUT SOURCE are.
5	Press Up Arrow until 1 or 0 is displayed.
6	Press ENTER to select. The cursor moves to the left and the display indicates your choice of 1 or 0 has been made.



**ATTENTION**

Note the difference between programming a discrete parameter with OFF and programming it with a 0. “OFF” means “not connected”; 0 means “off state”.

### 3.11 How to program function block parameters

The second type of programmable parameter is a function block parameter. A function block parameter’s data is contained within a function block and cannot be connected to another function block. When you are programming a function block and are not given a choice of PARM, you are programming a function block parameter. Typical choices when programming a function block parameter are NONE, OFF, any numerical value, or a list of options—but not PARM.

**Programming procedure**

Here is the procedure for programming a function block parameter. It is an example using a specific function block parameter, but the keystrokes used will apply when you are programming any function block parameter.

Continuing with the example from Figure 3-12, assume we want Analog Output#1 to default to its lowest value if the input source, LP2 OV, fails. Therefore, we must program Analog Output#1’s failsafe parameter with the appropriate selection. The following procedure shows how.

**Table 3-9 Example Function Block Parameter Selection Procedure**

Step	Action
1	In the Program Analog Output menu, select ANALOG OUTPUT#1.
2	Consult the Program Analog Output section of this manual to learn about the menu item you wish to change, namely, FAILSAFE.
3	Press the Down Arrow button to move the cursor down to FAILSAFE.
4	Press Enter to move the cursor to the right side of the display where the choices for FAILSAFE are.
5	Press Up Arrow or Down Arrow until DOWN is displayed.
6	Press Enter to select DOWN. The cursor moves to the left and DOWN is selected.

### 3.12 How to program a simple configuration

This section describes how to program your instrument. You should practice doing these procedures until you are familiar with the buttons and menus.

**Table 3-10 Function Block Configuration Procedure**

Step	Action
1	Select the desired function block from the Program menu.
2	Program each of the function block’s input parameters with OFF, a number, or an output code from another function block. See section 3.10 for this procedure.
3	Program each function block parameter with a number, selection, NONE, or OFF. See section 3.10 for this procedure.

*Continued*

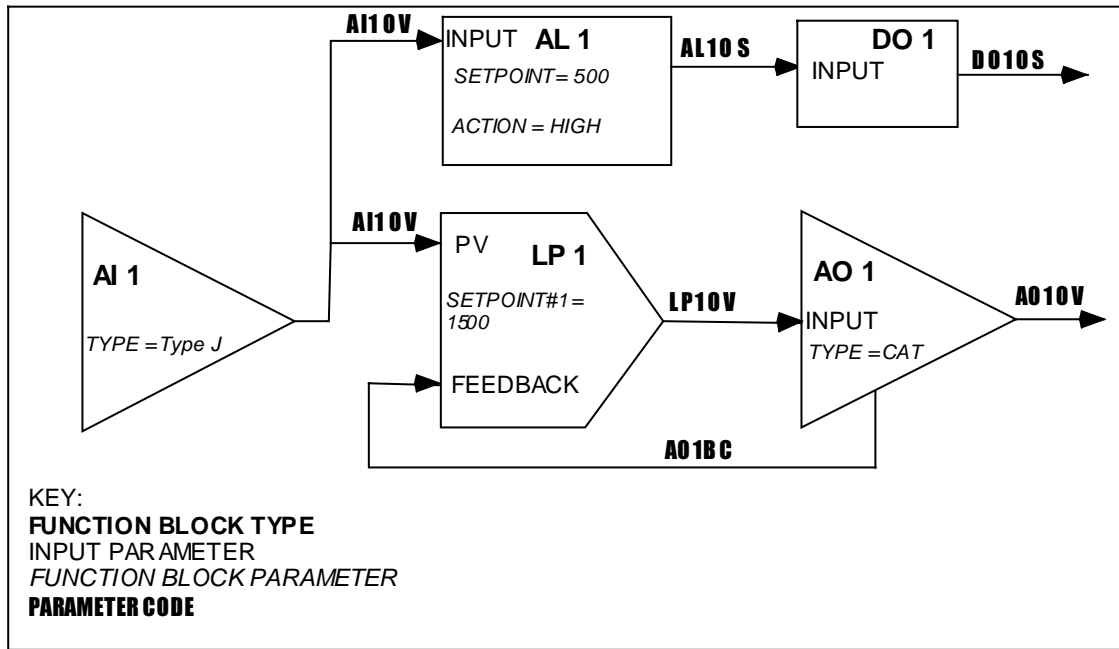
**Table 3-10 Function Block Configuration Procedure (continued)**

Step	Action
4	Program the function block's other items as desired. Other items include decimal point positions, descriptor, tag, and various labels for identifying the function block.
5	Repeat steps 1-4 for all desired function blocks until the instrument is configured.

**Example configuration**

Figure 3-14 shows a simplified configuration using typical function block connections. Note that several parameters are left out to simplify the drawing and procedure.

Table 3-11 describes how to program these connections.



**Figure 3-14 Example Configuration**

**Table 3-11 Example Configuration Procedure**

Function block type (Full name as displayed in the Program menu)	2. Select this input parameter from the function block's menu...	...and program it with this output code. See Section 3.10 for details.	3. Select this Function block parameter from the function block's menu...	...and program it with this choice. See Section 3.11 for details.
AI 1 (ANALOG INPUT #1)	--	--	TYPE	TYPE J
LP 1 (LOOP #1)	PV	AI1 OV	SETPOINT#1	1500
	FEEDBACK	AO1 BC		
AL 1 (ALARM #1)	INPUT	AI1 OV	SETPOINT	500
			ACTION	HIGH
DO 1 (DISCRETE OUTPUT #1)	INPUT	AL1 OS	--	--
AO 1 (ANALOG OUTPUT #1)	INPUT	LP1 OV	TYPE	CAT

### 3.13 How to program common configurations

Being able to diagram a control configuration in terms of function blocks makes it easier to program and configure your instrument for its intended process control application. This function block diagram you create can be used as a “construction blue print” to program the instrument. Each block in the diagram relates to a dedicated instrument programming menu in the instrument’s PROGRAM mode.

What follows are examples where common control configurations are presented along with their function block diagrams. The first example is a simple control arrangement in great detail to help you understand function block diagram basics, followed by more sophisticated examples. Once you understand how to diagram function blocks, you will be able to draw a diagram for virtually any control strategy regardless of complexity. Understanding the relationship between such diagrams and the instrument’s programming menus is key to successfully mastering the instrument’s many capabilities and features.

#### Programming a Current Driven Heat Treat Element

An example of one of the most common and simple control strategies is in Figure 3-15 below.

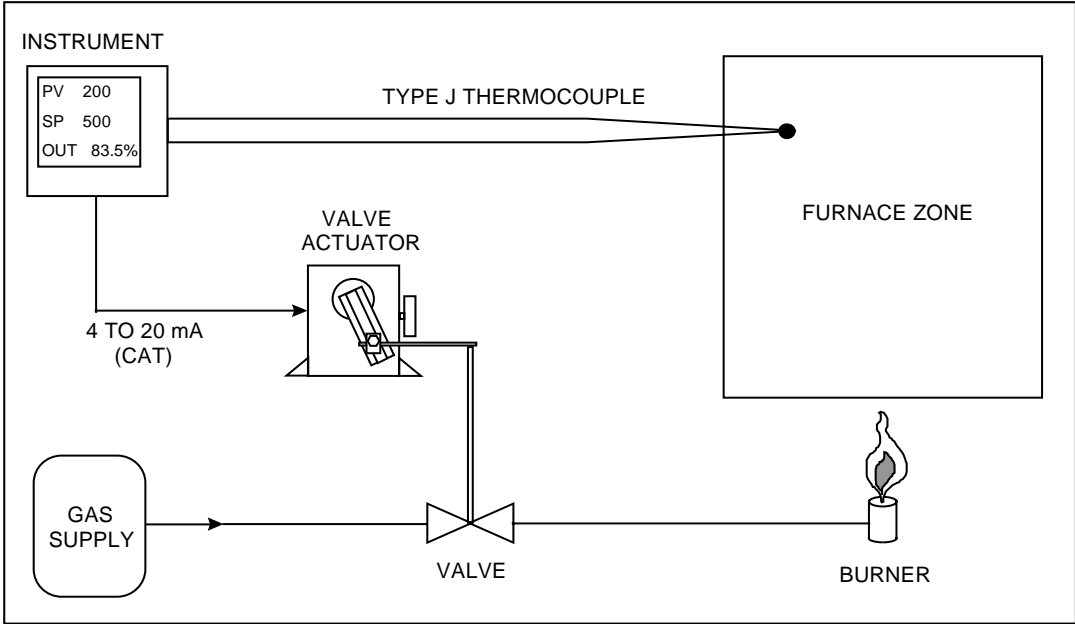


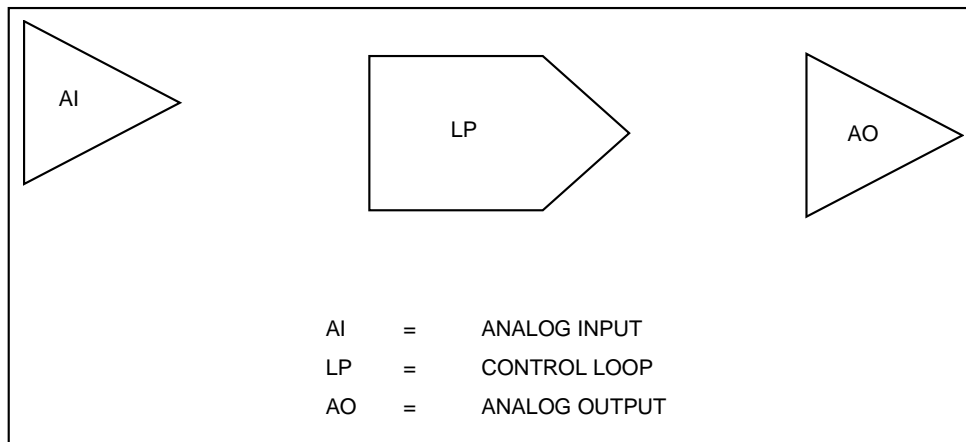
Figure 3-15 Control Of Furnace Zone Temperature With 4-20 mA (CAT) Control Signal

### 1. Diagram the function blocks

To configure this application using the instrument, your task is to build up a simple current control loop. Note that this control loop must monitor and control the temperature of the furnace zone to a local set point of 500 °F. Using a 4 to 20 mA signal applied to a gas valve actuator, the furnace zone’s temperature will be controlled by regulating the flow of gas to the zone’s burner. The instrument will measure temperature, in a range between 0 and 1000 °F, by means of a Type J thermocouple.

To support this application, a 4 to 20 mA control loop with a thermocouple process variable must be configured. Three function blocks—one for specifying a thermocouple analog input, a second for a standard PID control loop, and a third defining a 4 to 20 mA analog output—are needed to produce this control strategy’s function block diagram.

Each function block should first be arranged as in Figure 3-16. Analog input and output function blocks are represented by right-pointed triangles. Control loop function blocks are represented by right-pointed parallelograms.



**Figure 3-16 Basic Function Blocks Required For Control Configuration Of Figure 3-15**

### 2. Label input parameters

Properly label each function block. First, assign to each function block a name that identifies it within the hardware and feature capacities of the instrument being worked with. You may assign any of the analog inputs, control loops, and analog outputs that your instrument has to the blocks comprising the function block diagram drawn. For simplicity, AI1, LP1, and AO1 will be used in this example. Refer to Figure 3-17. Note that AI5, LP2, and AO2 could just as easily have been used.

### 3. Label output parameters

The second part in labeling each function block is to denote the blocks' major input and output parameters. Each of these parameters will correspond to actual menu settings that you program on the instrument. As shown in Figure 3-17, the AI1 function block's input parameter will be the actual Type J thermocouple run from the furnace to the instrument's AI1 input terminals. The AI1 block will process the thermocouple's millivolt signal to generate a temperature measurement. AI1's output value, denoted "AI1 OV", will essentially be the furnace zone temperature. The LP1 function block is shown, for now, with one input denoted by "PV". Here, the control loop block will expect to find the data comprising its process variable. The LP1 block's single output is the loop's main control output. Denoted "LP1 OV (Loop 1's Output Value)", it will range between 0 and 100 %. The value of LP1 OV at any given instant will be determined by the control loop function block's PID algorithm.

The last block in the diagram is the analog output function block, AO1. Drawn at this point with just a single input and output, its primary purpose will be to generate a 4 to 20 mA signal that linearly corresponds to whatever value is applied at its input. For example, if AO1's input is defined as some value that ranges from 0 to 100%, an input value of 0 % will cause AO1 to generate a 4 mA signal at the instrument's AO1 output terminals. A 12 mA signal will be generated in response to an input of 50%, while 20 mA will result when a 100% input value is applied. AO1's input parameter is denoted "IN", with its output parameter labeled to identify it as the physical 4 to 20 mA signal detectable at the pair of instrument rear terminals dedicated to AO1.

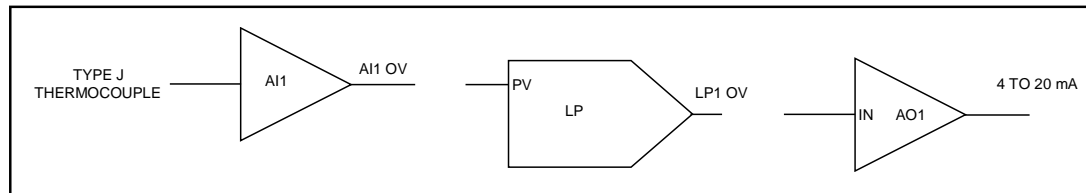
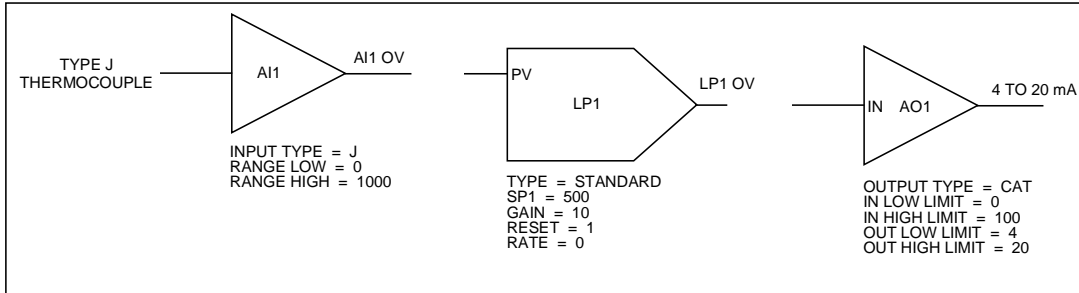


Figure 3-17 Labeling Each Function Block's Name And Major Inputs And Outputs

### 4. Label function block parameters

Finally, label each block's internal parameters. "Internal parameters" may also be referred to as "function block parameters." As in the case of input and output parameters, internal parameters associated with each block correspond to actual menu settings you program in the instrument. While input and output parameters constitute either data exchanged between function blocks or physical signals exchanged between the instrument and the outside world, internal parameters are settings that uniquely define the operation of the function block they are associated with. Use of a function block's internal parameters is for the most part limited to within the operations of the function block itself.

It is not always possible, or even practical, to draw every internal parameter that a function block has or might need. Therefore, as a rule-of-thumb for starting out, you should first think of internal parameters as simple labels that further define and clarify the internal operation of the function block. With this rule-of-thumb in mind, internal parameters become items that are hopefully intuitively obvious. At this point, what may or may not be an "intuitively obvious" internal parameter will depend on your level of process control expertise. For the function block diagram built up so far, internal parameters that can be presumed from the control strategy of Figure 3-15 are indicated in Figure 3-18. Here, the AI1 function block has been labeled to show that its "INPUT TYPE" will be a Type J thermocouple with a measurement range between 0 (RANGE LOW) and 1000 °F (RANGE HIGH). The label "STANDARD" has been used to indicate the type of control loop LP1 will be, along with the notation "SP = 500" to show that the loop's set point will be 500 °F. The loop tuning constants of GAIN, RESET, and RATE have been initially indicated as 10, 1 repeat/minute, and 0 minutes, respectively. As far as the AO1 function block is concerned, its input range has been defined between 0 (IN LOW LIMIT) and 100 (IN HIGH LIMIT) in anticipation of using LP1's output to drive the 4 to 20 mA signal it will generate. Note how AO1's output range has been defined through use of the notation "OUT LOW LIMIT = 4" and "OUT HIGH LIMIT = 20."

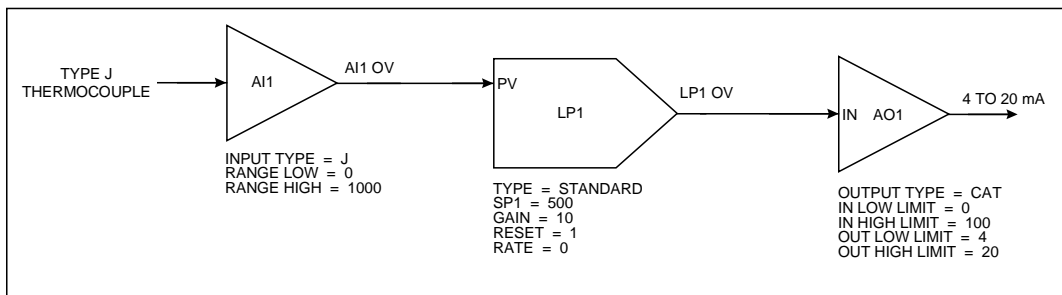


**Figure 3-18 Labels For Internal Function Block Parameters**

Note that the internal parameters that we have specified in the function block diagram built up so far are based largely on what can be inferred from the elements of the control configuration depicted in Figure 3-15. These internal parameters will relate directly to settings found in instrument programming menus that exist for each particular function block. As your experience and familiarity with programming the instrument increases, you will become more familiar with some of the less intuitive parameters and you will include these in your diagrams.

**5. Connect the blocks**

The next step is to connect the function blocks in the diagram. Refer to Figure 3-19. The interconnection lines drawn depict the flow of information between function blocks and represent how the blocks work together to support the complete control strategy. As shown, the furnace zone temperature measurement that AI1 generates will essentially be used as the process variable of the LP1 control loop. Based on the values of the loop’s tuning constants and on how far AI1 OV deviates from the 500 °F set point, the control loop function block’s PID algorithm will accordingly adjust LP1 OV to whatever value will be necessary to maintain the process’ set point. LP1 OV, which ranges from 0 to 100 %, will in turn be applied to AO1’s input to drive the 4 to 20 mA control signal applied to the valve actuator. By modulating the valve actuator’s position, this 4 to 20 mA signal will regulate the gas flow to the furnace zone burner and thereby allow the instrument to control the heat levels measured in the zone.



**Figure 3-19 Interconnections Between Function Blocks**

6. Draw the Feedback connection

To fully complete the function block diagram, one final and very important interconnection must be drawn. In setting up control loops in this instrument, a feedback path must be specified between the loop function block itself and the hardware element that externalizes the loop’s output to the real world. That is, the control loop block needs confirmation from the analog output block connected to it that the percent output levels it calls for have been correctly translated into accurate output signals. The feedback path that provides LP1 with this confirmation is established by means of program settings depicted in Figure 3-20.

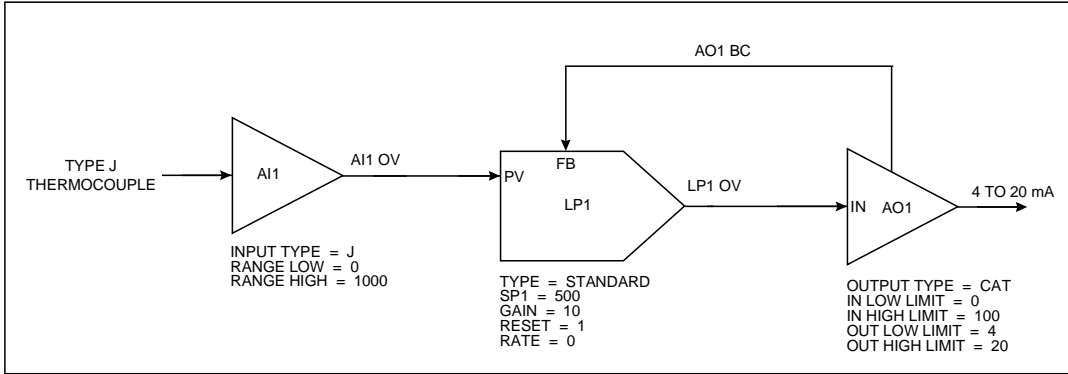
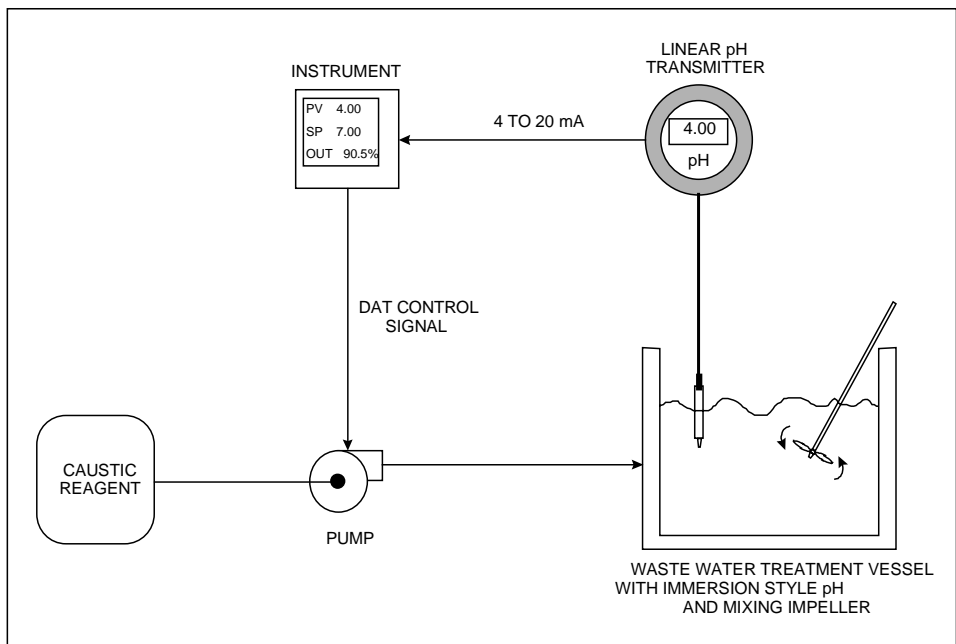


Figure 3-20 Complete Function Block Diagram Of Figure 3-15

Here, the function block diagram is drawn to include the key components of a typical loop feedback path. The AO1 function block has been changed to feature a second output denoted “AO1 BC.” This output has been connected to a feedback input at LP1 identified by the notation “FB.” The “AO1 BC” designator stands for “Analog Output 1’s Back Calculation.” When the control loop is brought on-line, AO1 BC will essentially represent the value of AO1’s 4 to 20 mA output at any particular instant. The term “Back Calculation” is used to reinforce the idea that this information is being sent “upstream” against the flow of all other information within the function block diagram.

### Time Proportioning Relay Driven Pump

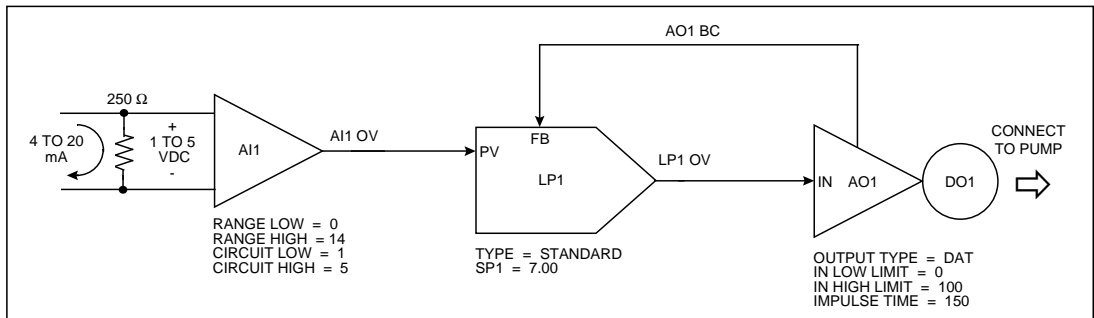
A second control scheme is to use a relay to produce a time proportioning or Duration Adjusting Type (DAT) control signal. Such an application is depicted in Figure 3-21.



**Figure 3-21 Control Of Wastewater pH Using A Time Proportioning (DAT) Control Signal**

This application requires a basic time proportioning control loop to monitor and control the pH of the wastewater to a local set point of 7 pH units. That is, the loop will “neutralize” the wastewater so that it can be safely released to the environment. The wastewater pH, which is assumed to be primarily acidic, will be controlled by introducing a caustic reagent to the contents of the treatment vessel. This will be done through use of a time proportioning relay signal that will pulse a pump connected to a caustic reagent source.

A function block diagram representing the control scheme of Figure 3-21 has been drawn in Figure 3-22. The same diagram method was used to produce Figure 3-20.



**Figure 3-22 Function Block Diagram Of Figure 3-21**

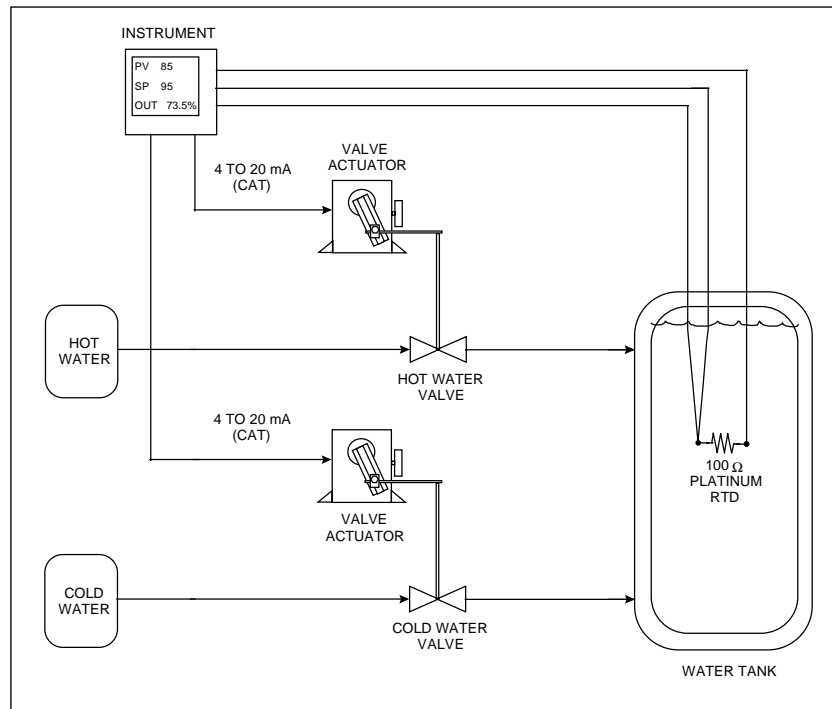
This drawing is similar to the temperature control application. The analog input, control loop, and analog output function blocks (AI1, LP1, and AO1) have been used similarly. The discrete output function block was added, drawn as a circle at AO1’s apex and named “DO1.” Recall that any analog input, control loop, analog output, or discrete output available may be used. Up to 24 discrete outputs (DO1 through DO24) are potentially available depending on the instrument’s model number.



From Figure 3-22, the instrument's AI1 function block will essentially process the 4 to 20 mA transmitter signal to generate a pH measurement. This measurement will be "AI1 OV" which, in turn, will be applied to LP1's process variable input, "PV." Before the 4 to 20 mA signal is applied to AI1, it will be converted to a 1 to 5 VDC signal with a 250 Ω shunt resistor. AI1 will be configured to generate a pH measurement in a range from 0 (RANGE LOW = 0) to 14 (RANGE HIGH = 14) in response to a voltage input between 1 (CKT LOW = 1) and 5 (CKT HIGH = 5) VDC. The PID algorithm of the control loop function block will adjust the value assumed by LP1 OV between 0 and 100%. This 0 to 100 % signal will be applied to AO1, which will be configured as a DAT type analog output. The internal parameter of "IMPULSE TIME" in AO1 is the DAT analog output's cycle time or period. With a specified impulse time of 150 seconds (an arbitrarily picked value), the DAT output will be ON for 75 seconds and OFF for 75 seconds when the input from LP1 is set to 50%. The ON and OFF times will be determined completely by the % output levels called for by LP1. Finally, to externalize the ON and OFF output states of AO1 to the outside world, the DO1 output relay, represented by the DO1 function block, will be programmed for AO1's exclusive use. Hence, as AO1 switches between ON and OFF states in response to LP1 OV's % output levels, so too will the DO1 output relay to generate the pulses required to drive the caustic reagent pump.

### Split Output or Duplex Control

Split output or duplex control loops are typically used in heat/cool applications. Temperature is controlled through simultaneous use of both heating and cooling elements. If the instrument was to support a heat/cool control configuration, an example of the control scheme that might be dealt with is illustrated in Figure 3-23.



**Figure 3-23 Temperature Control Of Water Using Split Output Or Duplex Control**

The instrument must be set up to produce two 4 to 20 mA control signals. By applying them to current-controlled valve actuators coupled to hot and cold water valves, these signals will regulate the amount of hot and cold water introduced to the vessel to maintain the water temperature at whatever set point will be programmed. The temperature of the water will be measured by means of a three-wire 100 Ω Platinum RTD. This process may be likened to manipulating hot and cold faucets regulate water temperature.

In Figure 3-24, the analog input function block AI1 is depicted processing the resistance values produced by the RTD. The resulting water temperature measurements (AI1 OV) are then fed to the process variable input (PV) of the LP1 control loop block. Note how LP1 has been defined as a split output control loop using the notation “TYPE = SPLIT.” Unique to this control loop is the defined range of its output value, LP1 OV. Where the standard control loops mentioned thus far have had outputs ranging exclusively between 0 and 100%, the % values of the split output control loop vary between -100 and 100. 0% is considered the midpoint for this control loop’s output range. When brought on-line, a 0 to 100% output value will be generated by LP1 when hot water is needed to maintain the temperature at set point. When the addition of cold water is necessary, the loop’s output will assume a value between 0 and -100%. Note that to externalize the control signals generated by LP1, two analog output blocks, AO1 and AO2, will be used. AO1’s 4 to 20 mA signal will be tied to the hot water valve actuator, while the actuator that adjusts the position of the cold water valve will receive its mA control signal from AO2. To provide AO1 and AO2 with usable input driving signals, LP1’s output will be applied to a function called a “standard splitter (STD SPLITTER).” Made from one of the instrument’s calculated value function blocks (“CV’s”), the standard splitter will essentially be a mechanism that translates the % values of the split output control loop into two distinct 0 to 100% signals. They will be applied to the inputs of AO1 and AO2 and, as such, will drive and linearly correspond with AO1 and AO2’s 4 to 20 mA outputs.

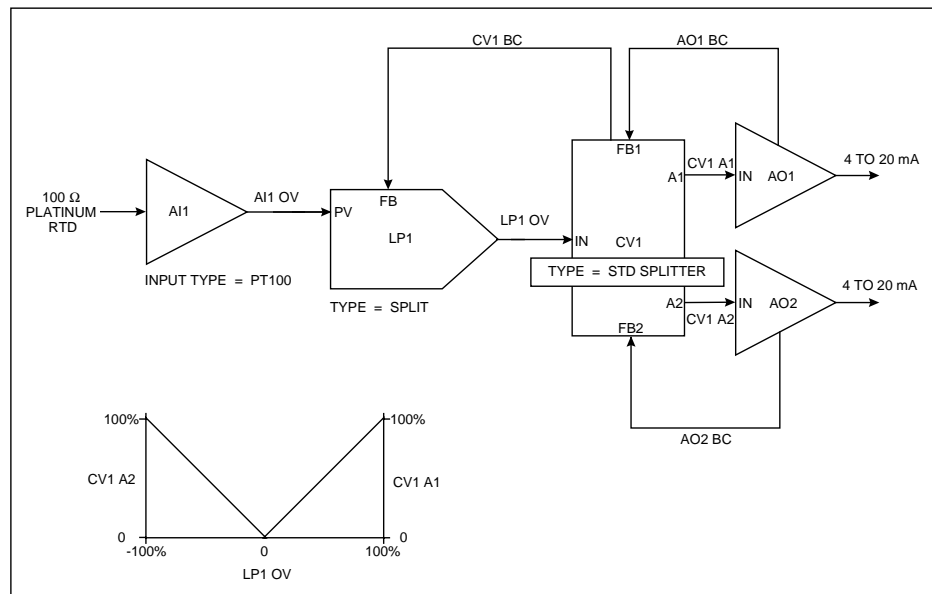


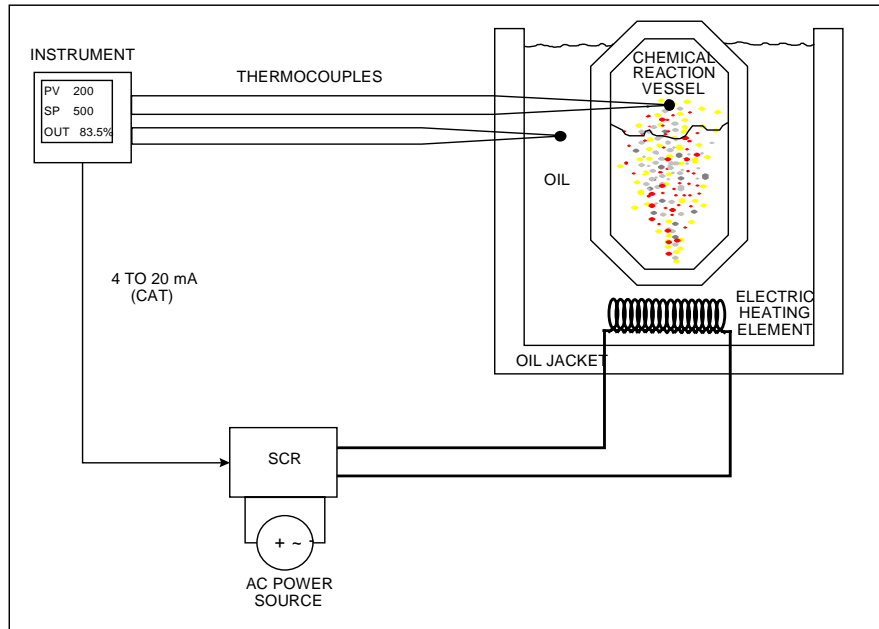
Figure 3-24 Function Block Diagram Of Figure 3-23

The two outputs on CV1 that will drive AO1 and AO2 are respectively labeled “CV1 A1” and “CV1 A2.” CV1’s basic operation is described by a plot of these outputs versus LP1 OV. Shown in the lower left of Figure 3-24, the plot demonstrates that CV1 will produce a 0 to 100% value at its CV1 A1 output when LP1 calls for an output level between 0 and 100%. CV1 A2 will remain at 0%. When applied to AO1, the CV1 A1 value will activate the 4 to 20 mA signal needed at the hot water valve actuator to make the water temperature in the vessel rise. Similarly, when LP1 calls for an output level between 0 and -100%, CV1 will produce a corresponding 0 to 100% value at CV1 A2. This time, CV1 A1 will remain at 0% and the CV1 A2 value generated will induce the introduction of cold water into the vessel to cool its contents down.

Note the function block diagram’s use of three back calculated feedback paths. Two such paths are labeled AO1 BC and AO2 BC. They are connected to CV1 from the analog output function blocks at inputs denoted “FB1” and “FB2.” CV1 BC, the third feedback path, runs from CV1 to the FB input of LP1. All three feedback paths work together to acknowledge to LP1 that the appropriate output signals have been generated in response to the % output levels the loop has called for.

## Cascade Control

An example of a cascade control application is featured in Figure 3-25. Cascade control is typically used when two process values must be simultaneously controlled, with one process value directly influencing the behavior of the other. In this control strategy, each process value is supported by its own dedicated control loop. The term “cascade” is used because it describes how this control approach literally attaches both control loops together. This act of linking control loops allows for the regulation of both process values using one and only one % output control signal.

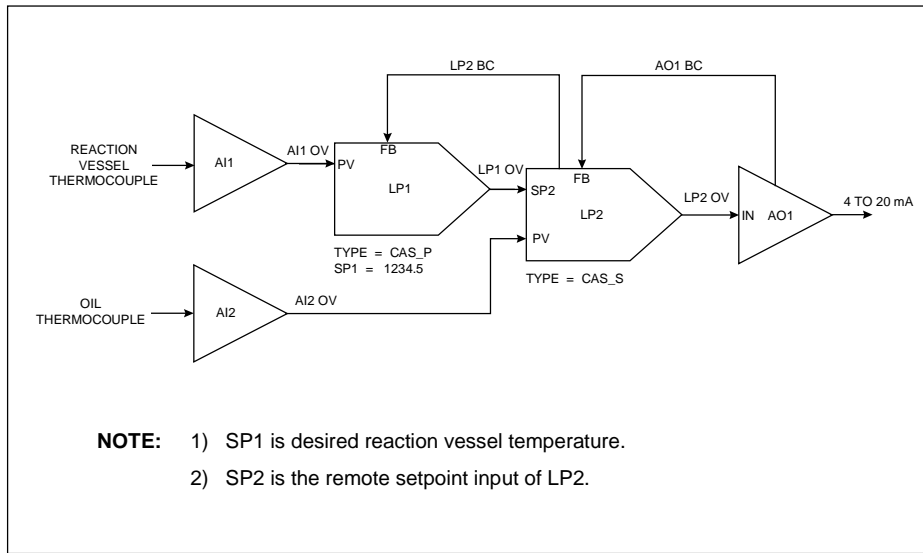


**Figure 3-25 Temperature Control Of An Oil Heated Chemical Reaction Chamber**

In Figure 3-25, the temperature in a chemical reaction chamber is determined by the temperature of the heated oil surrounding it. Heating the oil is done by an electric heating element driven by a 4 to 20 mA controlled SCR and external power source. In this application the instrument controls the temperature of the chemical reaction chamber through control of the heat emitted by the jacket tank oil. The instrument must provide a single 4 to 20 mA control output to govern the voltage switched by the SCR and, hence, the heat applied to the entire system. Temperature is monitored with thermocouples.

The function block diagram of the required instrument configuration is featured in Figure 3-26.

Note that this diagram illustrates the classic cascade arrangement of two control loops that defines the cascade control strategy. The first control loop, LP1, is designated as the primary cascade loop by the notation “CAS\_P.” The notation “CAS\_S” indicates LP2’s designation as the secondary cascade loop. Note how both control loops are joined together. In addition to the back-calculated feedback path set up between the two (LP2 BC), LP1’s output is connected to an input on LP2 that at this time must be introduced. Denoted as SP2, this input is LP2’s remote set point input.



**Figure 3-26 Function Block Diagram Of The Cascade Control Strategy**

Recall that based on the instrument’s model number, up to four control loops (LP1 through LP4) are potentially available for use within the instrument. *All control loops in this product may be programmed to operate using up to two user defined set point parameters, designated by SP1 and SP2.* Should you implement a control loop using one or both setpoints? That depends on what is necessary to meet the requirements of the specific application being dealt with. When in the on line mode and viewing a control loop’s dedicated on line display, the working set point of the live control loop can be switched between SP1 or SP2 by simply pushing the “SP” key on the instrument’s front bezel. Note that while both set point parameters may be programmed to have straight numeric values, only SP2 may be defined as a remote set point. That is, SP2 may be set up so that its value is determined by the output value of another function block, such as a setpoint profile. In the cascade control strategy demonstrated in Figure 3-26, SP2’s remote set point functionality is exploited by the LP2 secondary cascade loop. When this control configuration is made operational, LP2’s working set point, SP2, will have a value determined by LP1 OV.

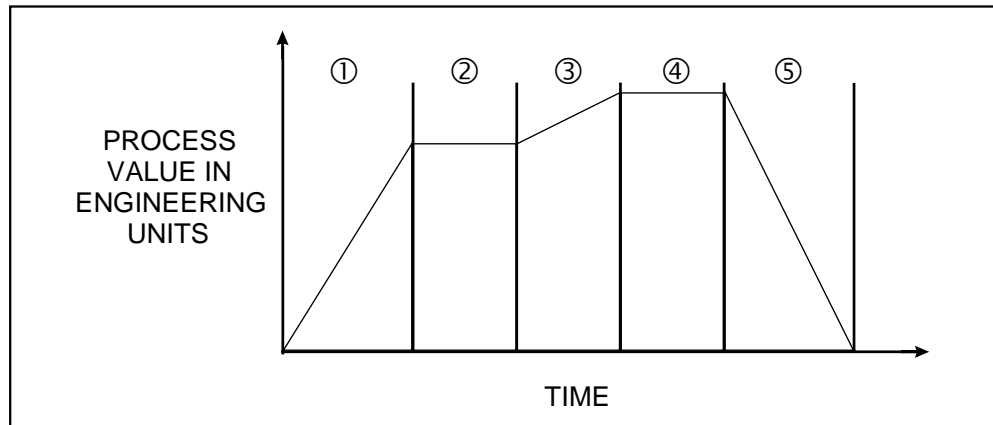
In Figure 3-26, the process values of each loop are the output values of the AI1 and AI2 analog input function blocks. AI1 will produce temperature measurements of the reaction chamber and provide them to the process variable input of LP1, while measurements of the oil temperature in the jacket tank will be furnished to LP2’s PV input by AI2. Because LP1 OV will provide LP2 with its operating set point, LP1’s output range will be defined in engineering units of temperature instead of the usual 0 to 100 %. LP2’s output range is 0 to 100%, in anticipation of using it to drive the AO1 function block’s 4 to 20 mA signal. Note that the range covered by LP1 OV will have to be consistent with the operating temperature range of the oil. For example, if it is determined that the oil temperature will be manipulated between 75 and 500 °F, the low and high limits assumed by LP1 OV (and, for that matter, SP2) will equal 75 and 500, respectively. Finally, LP2 BC and AO1 BC are the two back-calculated feedback paths shown. As is true for the operation of all back-calculated feedback paths, both LP2 BC and AO1 BC work together to acknowledge the cascaded control loops that the appropriate actions have taken place in response to both loops’ output values.

The method used to coordinate the tuning of the cascaded loops is particularly interesting. Using the diagram of Figure 3-26, the first priority is to tune the secondary cascade loop of LP2. With LP1 kept in manual mode, tuning may begin by first placing LP2 in manual mode and then manipulating LP1’s output. This will allow the generation an LP2 set point that will induce a process upset when the secondary loop is placed back in automatic mode. Only after LP2 has been tuned can LP1 be tuned. When tuning LP1, LP2 will be kept in automatic mode throughout the entire time LP1 is exercised. Since the tuning of LP2 will have already been established, tuning LP1 may be approached by first mentally “blocking out” the secondary control loop’s existence and visualizing LP1’s output as connected to a sort of virtual analog

output function block. In this light, tuning the overall cascade control configuration becomes the considerably simpler matter of tuning a single control loop.

### Set Point Profile Implementation

By definition, set point profiles are essentially user-specified plots of process values against time. These plots are characterized by “segments” which are a series of intervals of varying time lengths that divide the plots into several segments. Within each segment, process values are typically drawn as straight lines that ramp up or down or stay constant at predetermined levels. An example of a simple five-segment set point profile is shown in Figure 3-27. Set point profiles with up to 63 segments can be specified using the instrument. Note that when a segment depicts the process value as sloping up or down, it is referred to as a “ramp.” The term “soak” is used to describe a segment when the process value is made to stay constant. In Figure 3-27, segments 1, 3, and 5 are ramps while segments 2 and 4 are soaks.



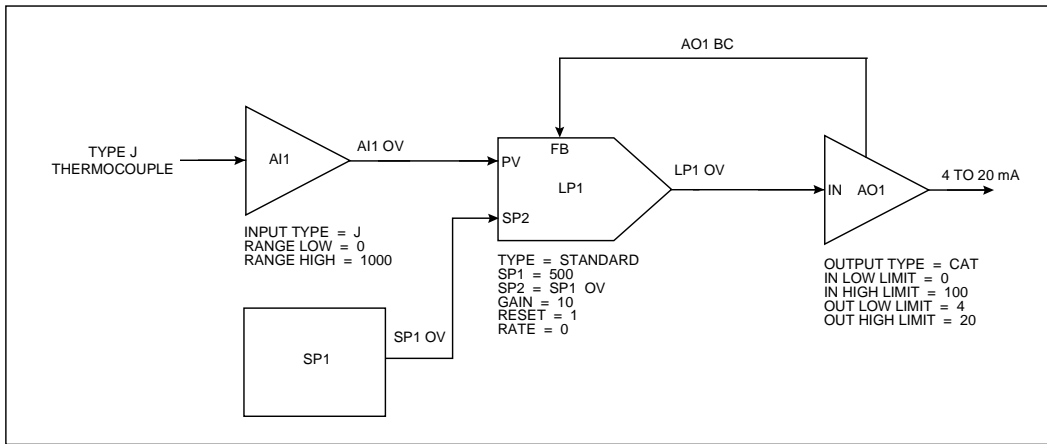
**Figure 3-27 Example Set Point Profile**

To force a process value to vary linearly with time at various rates within successive time intervals is the job of a set point profiler, another class of function blocks available within the instrument. Be advised that use of set point profilers is typically observed in thermal or heat treat applications. For example, being able to vary temperature in accordance with a set point profile is vital in the tempering of metal or ceramic parts.

Refer to the application of Figure 3-15 discussed at the beginning of this section. This application dealt with controlling a furnace zone’s temperature by means of a 4 to 20 mA gas valve actuator. If the furnace zone temperature were to be manipulated so that it followed the ramps and soaks of a set point profile, the first step would be to implement the function block diagram established in Figure 3-20. In general, the control configuration that holds a process value to a local set point, must be programmed and on line before allowing the process value to be characterized by a profile. With regard to the application at hand, a set point profiler function block programmed with a user defined set point profile may be brought into the configuration once the furnace zone’s basic temperature control loop is operational. Note that the output of the profiler function block will essentially be the set point profile.

From the cascade control strategy’s explanation, recall that all control loop function blocks within the instrument have a Setpoint #2 parameter that may be used as a remote set point input for connecting to the profiler’s output.

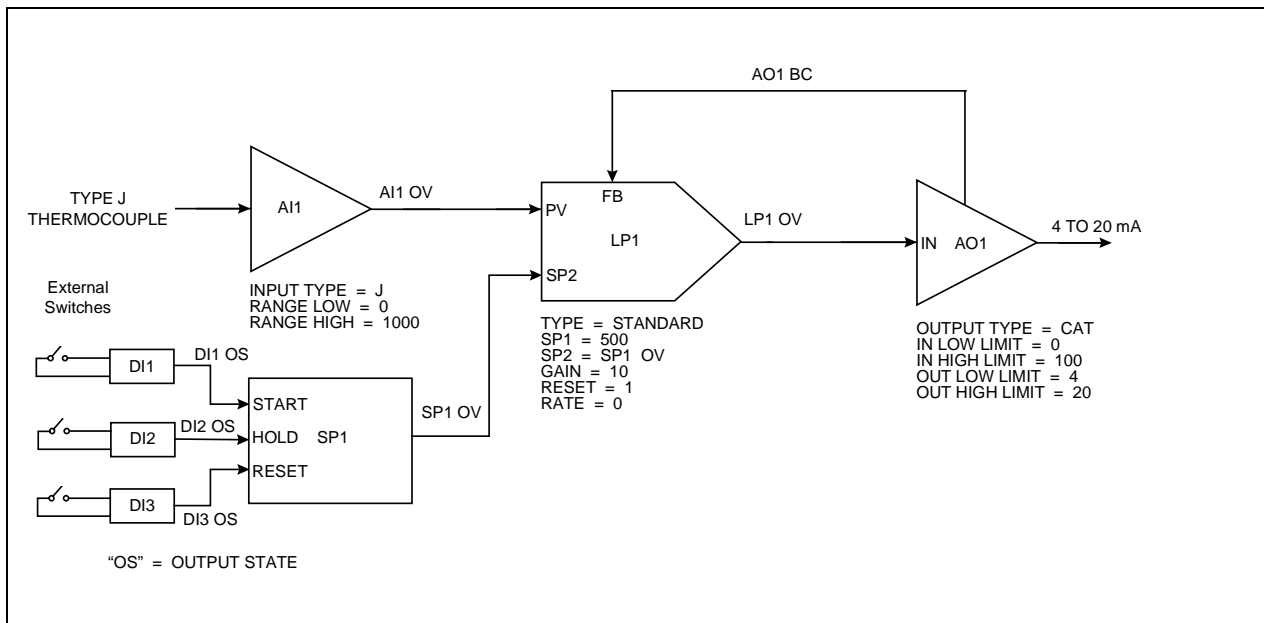
LP1 in the function block diagram of Figure 3-20 will make use of SP2’s remote set point functionality so that a set point profiler’s time varying set point may be applied to it. Refer to Figure 3-28.



**Figure 3-28 Function Block Diagram Of Set Point Profile Control Of Figure 3-20**

Figure 3-28 basically depicts all the components of the Figure 3-20's control configuration with a set point profiler function block denoted by SP1. The profiler's output (SP1 OV) is connected to the remote set point input of LP1. Depending on the model number of the instrument, up to four set point profiler function blocks (SP1 through SP4) may be included within the instrument's feature capacities. Note that while the profiler of SP1 was specified in Figure 3-28's diagram, any of the profilers within the instrument could have been used.

When a set point profile is executed, discrete inputs are typically used in conjunction with external switches to control the set point profiler function block. For example, the set point profiler function block can be programmed to start, hold, or reset based on discrete input statuses. See Figure 3-29.



**Figure 3-29 Discrete Inputs Controlling Execution Of Set Point Profiler Function Block**

Also typical in the execution of a set point profile is the generation of discrete events during each profile step. Discrete events are simply status indicators that are programmed to assume either an ON or OFF state during a step of a profile. As simple discrete status indicators, these events may, for example, be used to initiate a logic control scheme on the process being controlled upon the occurrence of a particular profile segment. In this product, note that up to 16 discrete events may be programmed per segment. See Figure 3-30.

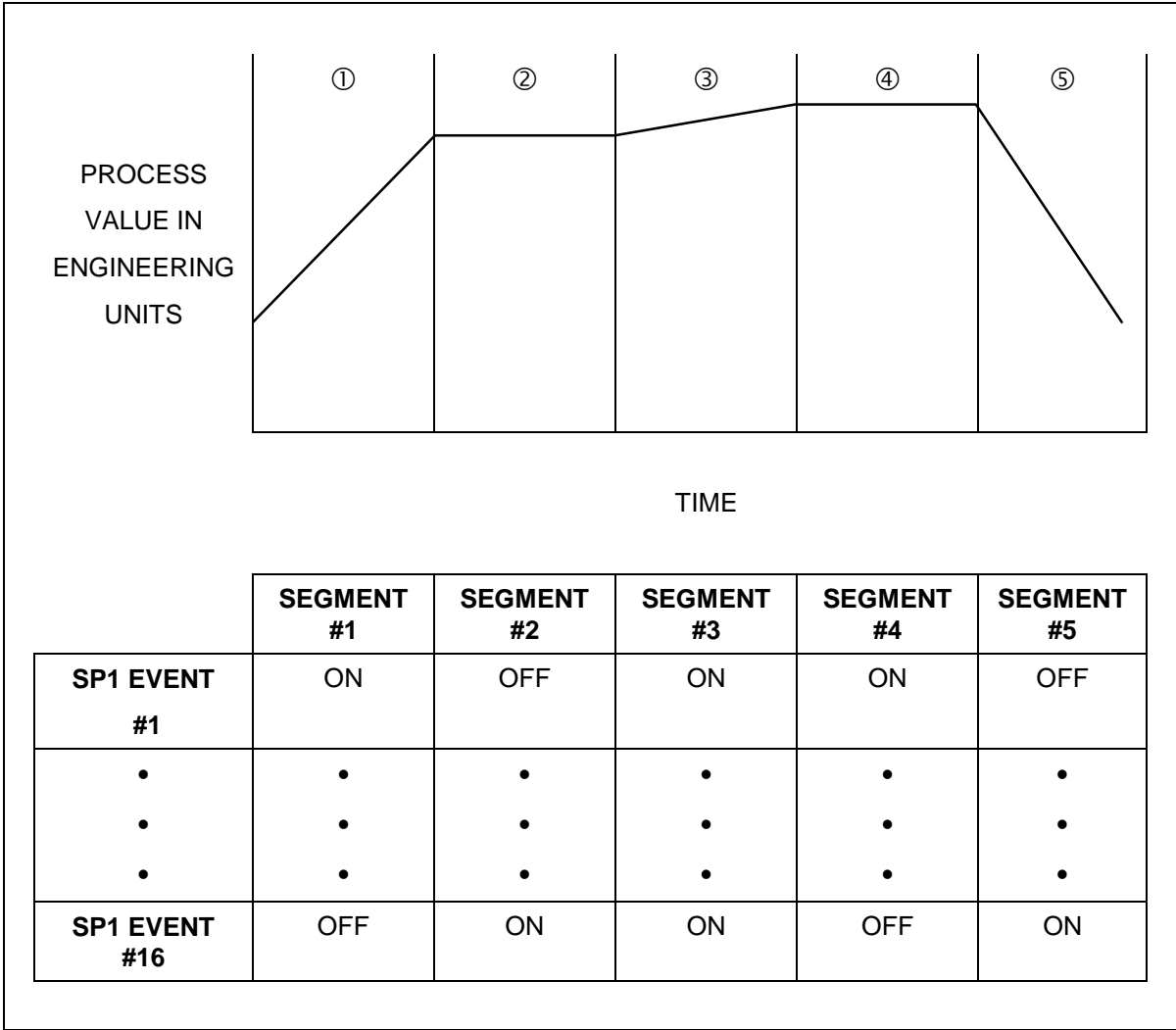
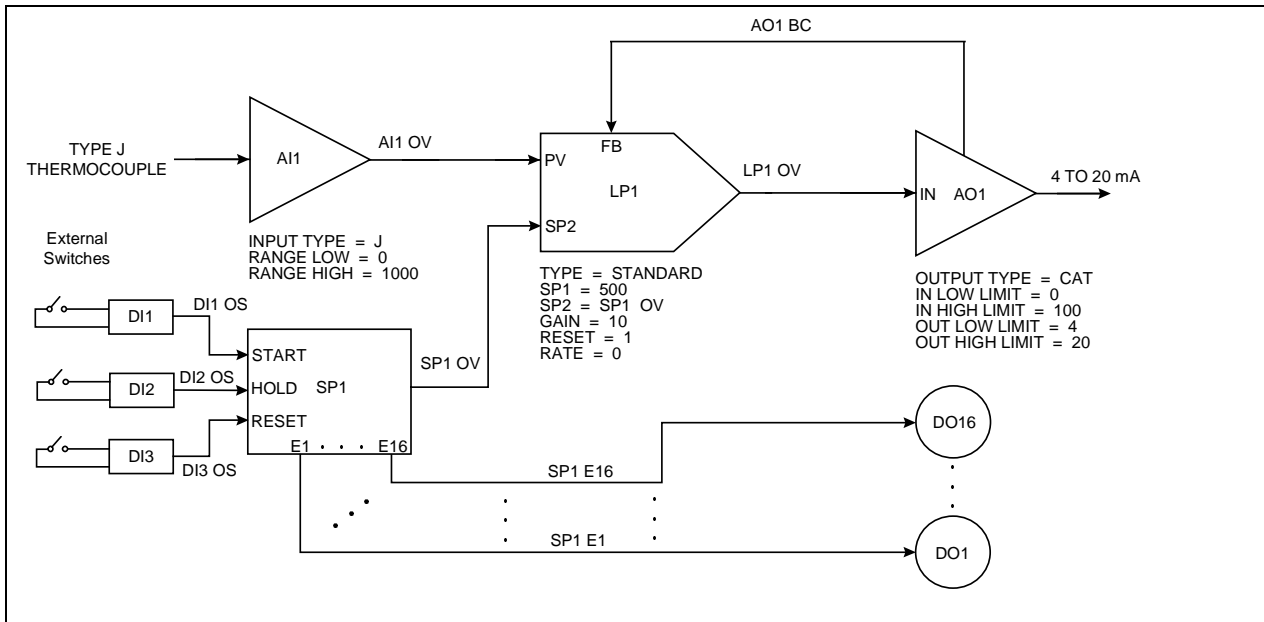


Figure 3-30 Up To 16 Discrete Events May Be Programmed Per Step Of A Set Point Profile

Discrete events, whose ON or OFF states depend on the step number of the profile they are associated with, may be externalized using the discrete output hardware available in the instrument. Figure 3-31 features the function block diagram elements that represent how to program the instrument’s discrete outputs so that their states coincide with those assumed by a profile’s discrete events.



**Figure 3-31 Tying A Profile Function Block’s Discrete Events With Discrete Output Hardware**

Refer to your instrument’s model number to verify its complement of discrete input and output hardware. The available combinations of discrete inputs and outputs are featured in the Specifications section.



### 3.14 Data Storage

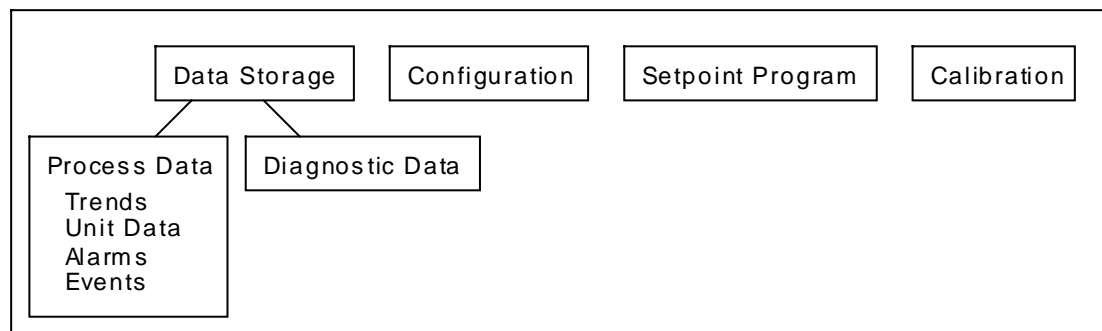
A unique feature of the instrument is its handling of data storage to 1.44 MB or 120 MB disks. The unit's front bezel must be closed for any disk drive operations to take place. 1.44 MB disks may be formatted in the instrument or on a PC.

Read this overview thoroughly to understand the fundamentals behind the instrument's data storage capabilities.

#### Categories of Stored Data

There are four categories of disk storable data. Each category of data is stored in its own unique file. The categories are:

1. Data Storage
2. Configuration Storage
3. Setpoint Program Storage
4. Calibration Storage.



**Figure 3-32 Categories of Stored Data**

The first category of stored data, Data Storage, is comprised of two types of data: process data and diagnostic data. When the instrument stores these data types it is essentially functioning as a recorder.

Process data is comprised of up to six files containing historical information on the process that the instrument is monitoring and/or controlling, such as the temperature trend or a log of a furnace over time. Process data also includes any alarm or discrete event information.

Diagnostic data is the result of the instrument's execution of diagnostic routines during instrument start-up and maintenance procedures (such as calibration). Online operation is also monitored to detect both process faults and internal electronic errors. If a diagnostic error occurs, a record of it can be stored to a single diagnostic file.

The second category of stored data is configuration storage, which is a single file comprised of the instrument's programming and configuration. Configuration storage includes the programming of the instrument's analog input characteristics, the configuration of its control loops, or, perhaps, the programming of any math or logic functions.

The third category of stored data is Setpoint Program storage, which is a single file—a setpoint program—containing one to four setpoint profiles, depending on the instrument. Recall that set point profiles are user specified plots of process values against time that are divided into ramp and soak segments of varying time lengths. Setpoint programs may be stored to disk or to the instrument's memory.

The fourth category of stored data is calibration storage, which is a file containing the instrument's analog input and output calibration. This file may be used to restore calibration in the event that a full calibration, using a calibration source and/or meter, cannot be performed.

1.44MB disks are restricted to having files of the first category, Data Storage, stored on a disk dedicated to that category and not stored on disk with the other categories of storage. Files of the other three categories –configuration, set point program, and calibration– may occupy the same disk. 120MB disks can have multiple types of data stored on them.

### Performing Data Storage

Configuring the instrument to store the first category, Data Storage (process and diagnostic data) is done through an Online menu entitled DATA STORAGE. All aspects of preparing a DOS formatted disk to accept process and diagnostic data information are managed through this menu’s selections. Process and diagnostic data may be stored on the same disk, but not along with other storage types (i.e., configuration, setpoint programs, or calibration).

The four types of process data are:

1. Trends - Data comprising the classic horizontal or vertically oriented time-varying traces that represent process parameters.
2. Unit Data - Process parameter information collected and displayed in tabular or datalog format.
3. Alarms - A record of any alarms that activated while the instrument was monitoring and/or controlling your process.
4. Events - A record of any discrete events that might have occurred while the instrument was monitoring and/or controlling your process. Discrete events may occur, for example, in the instrument’s execution of a set point profile.

When the instrument is On line and performing Data Storage, a separate and distinct disk file will be established for each process data type along with a file for diagnostic errors. Each file will be distinguished by a file extension as indicated in Table 3-12.

**Table 3-12 Data Storage File Extensions**

Data Type	File extension
Trends	.LNT
Unit Data	.LNU
Alarm History	.LNA
Discrete Event	.LNE
Diagnostics	.LND

You can specify which process data types are written to disk and whether or not diagnostic errors are stored by setting up data storage schedules, accessible under a prompt entitled SET UP NEW SCHEDULES under the DATA STORAGE menu. Up to seven files may be written to disk while the instrument performs Data Storage – three trend files, one unit data file, one alarm file, one event file, and one diagnostics file.

SET UP NEW SCHEDULES lets you designate several other parameters, such as the data storage rate (i.e., the distance in time between adjacent samples of a recorded process data parameter), the eight-character file names used to identify each process and diagnostic data file, and whether or not the Data Storage takes place in continuous or batch modes. Data Storage files may be configured to “rollover” after they have become full. That is, after the space on the disk for each file type has run out, all of the oldest data on the disk is overwritten with the most recent data.

## Initializing a disk

To activate the new data storage schedules that have been configured in the SET UP NEW SCHEDULES menu requires you to “initialize” the DOS formatted floppy disk to which process and diagnostic data will be stored. This is done by executing a routine entitled INITIALIZE DISK, also found in the DATA STORAGE menu. The task of initializing a disk and activating data storage schedules are one and the same.

### ATTENTION

Initializing a disk is only necessary for performing Data Storage. You do not have to initialize a disk to perform Configuration, Set Point Program, or Calibration Storage

When executing the INITIALIZE DISK menu prompt, you will observe two selections: USE NEW SCHEDULES and USE CURRENT SCHEDULES. The “SCHEDULES” in both selections refer to the data storage schedules prepared in the SET UP NEW SCHEDULES menu described earlier. USE NEW SCHEDULES to initialize the disk to activate a newly configured data storage schedule for the very first time. The only time you will USE NEW SCHEDULES again is after you have made any changes to the way the data storage schedules have been configured. You must USE NEW SCHEDULES to initialize the disk in order for these changes to take effect. USE CURRENT SCHEDULES to initialize a disk if the disk will replace one that has become full. This will ensure that data being recorded continues uninterrupted over the space of both the full and replacement disks. During the time when the full disk is being replaced with a new disk, recorded data will be stored to the instrument’s memory buffer. Upon completing initialization via the USE CURRENT SCHEDULES prompt, all buffered data will be written to the new disk and data storage will resume, with no lapses of storage between disks.

During initialization, the disk’s surface is scanned for bad clusters to ensure its integrity. If any cluster is determined to be bad, the disk will be rejected and the initialization will fail. Disk initialization also allocates sections of the disk to each of the files you have elected to store per the SET UP NEW SCHEDULES menu. Once the instrument completes initializing the disk, process and diagnostic data recording begins immediately, indicated by a yellow-colored letter “S” in the lower right hand corner of the instrument screen.

## Data Storage Status

The prompt DATA STORAGE STATUS, accessed from the Online DATA STORAGE menu, displays a calculation of how long a particular floppy disk will last based on the configured data storage schedule. Disk capacity is indicated in days, hours, and minutes remaining on the disk.

After the instrument has been Online and actively performing Data Storage to floppy, a warning message will appear when the disk reaches the default 90% capacity, or a user-specified capacity. Once a disk has reached its programmed capacity, a DISK FULL message will be displayed.

## Process and Diagnostic Data Integrity

The instrument is equipped with several features to ensure data integrity. The instrument will not store data to disk if its front bezel is open. A BEZEL OPEN message will appear on all displays and process and diagnostic data meant for disk storage will be kept in the instrument’s memory buffer. Data corruption and loss are, therefore, not issues if someone walks up to the instrument and simply removes the Data Storage disk. Note that when performing Data Storage, the instrument writes to the disk only once a minute. This ensures that the latest data is always on disk. In the event of a power failure, at most one minute of data would be lost.

### Performing Configuration and Calibration Storage

Configuration and calibration storage is performed through a Program mode MAIN MENU prompt LOAD/STORE CONFIG. Here, a file containing the instrument's programming and configuration is created by executing a routine called STORE CONFIG TO DISK. Similarly, creation of an instrument calibration file is performed via a STORE CALIB TO DISK menu choice. Configuration and calibration files will be distinguished by eight-character names that you will specify. The applicable file extensions for both file types are shown in Table 3-13.

**Table 3-13 Configuration and Calibration Filename Extensions**

Storage Type	Filename extension
Configuration	.LNC
Calibration	.LNL

Note that an instrument configuration file may also be created and stored to disk using optionally purchased SCF Configuration Software. You do not need a live instrument to create a configuration file using SCF.

Once stored to disk, the instrument configuration file may be downloaded into other instruments that have an identical model number. This helps to greatly reduce the amount of time required to program and configure multiple units sharing the same application. Having the instrument configuration on disk can also drastically minimize down time in the event of an instrument failure. The file can be used to program and configure a replacement unit within seconds. As far as the calibration file of the instrument is concerned, it can be used to restore analog input and output calibration if use of a calibration source and/or meter is not possible or an inconvenience.

### Performing Set Point Program Storage

Refer to Section 5 of the manual for a detailed explanation of how Set Point Program Storage is accomplished.

## 4. How To Program Function Blocks and Features

### 4.1 Overview

This section describes all the programming procedures to get your instrument up and running, except Profiles which are discussed in Section 5. It describes the entire Program Mode menu and some items from the Online Mode menu.

#### What's in this section?

The following topics are covered in this section.

Topic	Page
Programming Tips	78
The Program Mode Menu	79
Frequently used programming parameters	80
Set Mode	81
Enter Labels	82
Program Analog Inputs	85
Program Control Loops	89
Program Analog Outputs	100
Program Discrete Inputs	104
Program Discrete Outputs	105
Program Calculated Values	106
Program Alarms	144
Program Totalizers	146
Program Profiles	148
Program Constants	149
Copy Block	151
Program Displays	152
Enable Features	163
Program Security	164
Program Serial Communications	165
Set Clock	166
Configuration/Calibration Store & Load	167
Scan Rate	168
Select Language	169
Data Storage	170

## 4.2 Programming tips

- See Section 3 for general programming procedures.
- Before programming a function block's input parameter with a CV's (Calculated Value) output parameter, you must program the CV first; otherwise, the CV's output parameter will not be available for programming.
- The function block SY (System Parameter) operates internally and has no menu. It automatically produces outputs which reflect the status of alarms, data storage, diagnostics, and reference junction temperature. These outputs can be programmed as inputs to function blocks. See Table 3-5 in Section 3.
- Each function block can be labeled with custom descriptors and tags to identify the function on displays. You can enter these labels under the menu item ENTER LABELS or within each function block's menu item. See Section 4.4 Frequently used programming prompts.
- All Program mode menu items and settings can be reviewed but not changed in the Online mode by selecting "REVIEW PROGRAMMING" on the main Online menu. See Enable Features, Section 4.19.
- We recommend you save the instrument configuration to a disk after you have completed programming the instrument. See 4.23 Load/Store Config.
- Prior to programming and configuring the instrument for its intended application, it is highly recommended that a copy of the instrument's factory calibration be stored to floppy disk. To do this, place a formatted, high density, 1.44 MB, 3½" disk into the unit's disk drive and access the **PROGRAM** main menu. Choose **LOAD/STORE CONFIG** and then select **STORE CALIB TO DISK**. Keep this disk in a safe place and use it to restore the instrument's calibration to factory settings if the need arises.

### 4.3 The Program mode menu

Program mode is an off-line mode for programming (configuring) the instrument. In this mode, all outputs are frozen.

Table 4-1 shows the top level of the Program Mode menu with all available options. Your instrument may have a reduced menu if options are not present or if features have been disabled.

**Table 4-1 Program Mode Menu**

Prompt	Function
SET MODE	Change operating mode of programmer
LABELS	Enter descriptive labels for parameters using instrument's buttons or a QWERTY keyboard or barcode reader.
ANALOG INPUTS	Program Analog Inputs.
CONTROL LOOPS	Program Control Loops.
ANALOG OUTPUTS	Program Analog Outputs.
DISCRETE INPUTS	Program Discrete Inputs.
DISCRETE OUTPUTS	Program Discrete Outputs.
CALCULATED VALUES	Program Calculated Values.
ALARMS	Program Alarms.
TOTALIZERS	Program Totalizers.
PROFILERS	Program Setpoint Profiles.
CONSTANTS	Program Constants.
DISPLAYS	Assign primary Online displays to the Display button.
FEATURES	Enable/disable certain menu items.
SECURITY	Enable/disable security on certain items.
SERIAL COMM	Program Serial Communication.
COPY BLOCK	Copy any function block to another channel.
CLOCK	Set time and date.
LOAD/STORE CONFIG	Store and load configurations/calibrations.
SCAN RATE	Set scan rate of instrument.
LANGUAGE	Select language of instrument.

## 4.4 Frequently used programming prompts

When programming the instrument you will see certain prompts repeatedly in different menus. These are described in Table 4-2, rather than in each menu in which they appear.

**Table 4-2 Frequently Used Programming Prompts**

Prompt	Range/Selections	Definition
IN DECIMAL POS	X.XXXXX      XXXX.XX XX.XXXX      XXXXX.X XXX.XXX      XXXXXX. X.XXEXX	Select the decimal point position to be used for all inputs to the function. Select X.XXEXX to display the function's values in exponential notation. Example: 1.23E4 means $1.23 \times 10^4$ .
OUT DECIMAL POS	Same as IN DECIMAL POS selections	Select the decimal point position that will be used for all outputs of the function.
ON LABEL*	OFF   ON      FILL   DRAIN UP    DOWN    EMPTY FULL START STOP    IN    OUT LOW   HIGH    OPEN   CLOSED RESET RUN     HOLD   ACTIVE TRUE   FALSE   READY   ABORT LEFT   RIGHT   ALARM   NORMAL DECRS INCRS   AUTO   MANUAL LOAD   UNLOAD   SP1   SP2 COOL   HEAT    NO    YES PAUSE	Select the discrete function's ON(1) state label.
OFF LABEL*	Same as ON LABEL selections	Select the discrete function's OFF state label.
DESCR*	Enter up to 16 characters.	Usually appears as a header or title on some displays and reports. For alarms, this is the actual alarm message.
TAG*	Enter 7 characters maximum.	Identifies the point or function on most displays and reports. <i>Each tag must be unique.</i>
UNITS*	Default choices: PSI    DEGR    GAL    MA BAR    K          LPH    % MW    MV          LPM    PH GPH    V          LPS    KG GPM    OHM        LITR   GRAM GPS    HZ          DEGC   LB DEGF	Shows units of measure for analog values on most displays and reports. These 25 choices can be changed. See Table 4-4.

\* Prompt does not appear if labeling is disabled under ENABLE FEATURES.



## 4.5 Set Mode

Select this item to change the operating mode of the instrument to Online, Program or Maintenance. The top of the display will show which mode you have changed to.

### Program mode

Program mode is an off-line mode for programming (configuring) the instrument. In this mode, all outputs are frozen.

### Online mode

Online Mode enables full use of the instrument with its inputs, outputs and internal programming. In this mode, it is fully interactive with all externally connected elements.

### Maintenance mode

Maintenance Mode is an off-line mode for maintaining proper and complete functioning of the instrument. Functions include calibration, off-line diagnostic testing, and various setups for operation. In Maintenance Mode, all outputs are frozen.

---

### ATTENTION

---

Note: Changing to ONLINE mode by pressing any of the Display buttons can cause incorrect values to be displayed. The values will correct themselves in a few seconds. To avoid this potential annoyance, change to online mode through SET MODE instead of through the Display buttons.

---

## 4.6 Enter Labels

### Overview

Labeling lets you use the front panel buttons, a QWERTY keyboard, or barcode reader to assign custom text identifiers to most data and functions to make them easily recognized on displays. Labeling items makes programming and operation easier but is not required. You can assign all labels here or at each individual programming menu (that is, at Program Analog Inputs, Program Alarms, etc.). For the latter, you must enable labeling under ENABLE FEATURES in the main Program menu.

### Entering labels with the front panel buttons

Use the Up Arrow and Down Arrow keys to move the cursor and select a character. See Table 3-1 for these buttons' functions. If you are entering several labels, this method can be tedious because you must scroll through A-Z and 0-9 to pick each character. Consider using a keyboard or barcode reader instead.

### Entering labels with a QWERTY keyboard

Using a QWERTY keyboard is easier and faster if you are entering many labels. See Section 3.7 for keyboard connection procedure.

To enter label with the keyboard:

1. Select Enter Labels.
2. Select the function block whose label you want to change.
3. Select the label you want to change (Table 4-3).
4. Press Enter to move cursor to the right side of the display.
5. Type in the new label with the keyboard. The instrument accepts A...Z, a...z, 0...9, (, ), -, +, /, \*, ^, (.), =.
6. Press Enter to accept the new label.

### Entering labels with a barcode reader

Using a barcode reader is easier and faster if you are entering many labels. See Section 3.6 for barcode reader connection procedure.

To enter label with the barcode reader:

1. Select Enter Labels.
2. Select the function block whose label you want to change.
3. Select the label you want to change (Table 4-3).
4. Press Enter to move cursor to the right side of the display.
5. Scan in the new label with the barcode reader. Allowable characters are: 0...9, A...Z, -, +, /.
6. Press Enter to accept the new label.

After selecting ENTER LABELS, choose an item (such as Analog Inputs) to label. Use the prompts in Table 4-3. All text and numeric keys may be used for labels; no characters are prohibited. To cancel an entry, press the ESC key on the QWERTY keyboard or press the Menu button on the front panel.





## 4.7 Program Analog Inputs

To program Analog Inputs, select PROGRAM ANALOG INPUTS on the Main Program Menu. Select an AI to program.

**Table 4-5 Analog Input Algorithm Selection**

Prompt	Range/Selections	Definition
INPUT ALGORITHM	Standard or Custom	<p>This prompt appears only if “CUSTOM INPUT” is enabled under Enable Features in the Program Mode Menu (Section 4.19). If “CUSTOM INPUT” is disabled you will see the Standard prompts (Table 4-6).</p> <p>Standard lets you choose a thermocouple, RTD, EMF, or pyrometer type. The Standard prompts are shown in Table 4-6.</p> <p>Custom lets you convert the input from a thermocouple or EMF to engineering units using a custom curve containing up to 20 points.</p>

### Standard algorithm prompts

Table 4-6 describes all the prompts associated with the standard algorithm. These are the default prompts for analog input programming. See Table 4-2 for additional prompts.

**Table 4-6 Standard Algorithm Prompts**

Prompt	Range/Selections	Definition
INPUT TYPE	See Table 1-3 for selections. The default type is OFF.	Input type (thermocouple, RTD, pyrometer)
RANGE LOW	The value must be within the limits specified for the input type (see Table 1-3). Be sure to use the correct value for the temperature units used (°F, °C, K, °R). To enter the full range for the temperature units selected (see TEMPERATURE UNITS), select TYPE again and press Enter without changing the range type.	Low end of the input range.

**Table 4-6 Standard Algorithm Prompts (continued)**

Prompt	Range/Selections	Definition
RANGE HIGH	The value must be within the limits specified for the input type (see Table 1-3). Be sure to use the correct value for the temperature units used (°F, °C, K, °R). To enter the full range for the temperature units selected (see TEMPERATURE UNITS), select TYPE again and press Enter without changing the range type.	High end of the input range.
TEMPERATURE UNIT	Select C for Degrees Celsius, F for Degrees Fahrenheit, K for Kelvin, R for Rankine, or NONE.	Specifies the temperature units used for thermocouple, pyrometer, and RTD input types. The default setting is F. If you change the default, be sure to change the analog input's RANGE LOW and RANGE HIGH values accordingly. The instrument will not adjust these values by itself. Ignore the TEMPERATURE UNIT prompt or set it to NONE, if the analog input being programmed will not be used for temperature measurements.
DIRECT/INDIRECT	Select DIRECT for thermocouple, pyrometer, or RTD inputs. Select INDIR (Indirect) for volt or millivolt signal inputs from linear or non-linear transmitters. Select SQRT (Square Root) for extracting flow measurements from a voltage input representing differential pressure measurements. If SQRT is chosen, the RANGE LOW and RANGE HIGH must be adjusted to specify the upper and lower limits of the flow units span.	Note that the term "direct" generally applies to input types where the sensors in direct physical contact with the monitored process are also in direct physical contact with the instrument terminal board. The term "indirect" applies to inputs from transmitters since the sensors in direct physical contact with the monitored process are indirectly connected to the instrument through the transmitter circuitry and wiring.
CIRCUIT LOW	OFF or number	Appears only if "INDIR" or "SQRT" was previously selected. Is the actual low end value of voltage to be used for Indirect measurements.
CIRCUIT HIGH	OFF or number	Appears only if "INDIR" or "SQRT" was previously selected. Is the actual high end value of voltage to be used for Indirect measurements.
ELECTRICAL UNITS	Select whether the CIRCUIT LOW or CIRCUIT HIGH values specified are in units of VOLTS, MV (millivolts), or OHMS.	Circuit low and circuit high units.
LAG	≥ 0 seconds or OFF	"LAG" is a time constant applied to the input measurement value. This provides digital filtering (LAG) to the measurement.  Lag appears on menu only if EXPANDED INPUT is enabled under Enable Features in the Program menu.

**Table 4-6 Standard Algorithm Prompts (continued)**

Prompt	Range/Selections	Definition
SAMPLE HOLD	OFF, discrete parameter, 0, 1	Holds Input. The input value is measured normally when this discrete is OFF and holds its last value when the discrete is ON (1).  Hold appears on menu only if EXPANDED INPUT is enabled under Enable Features in the Program menu.
FAILSAFE	For thermocouples only, Upscale (UP), Downscale (DOWN) or None.	Determines whether or not failsafe is active and, if so, which direction
CLAMPING	LO RANGE clamps input at the RANGE LOW value. HI RANGE clamps the input at the RANGE HIGH value. RANGE clamps input over both the low and high range values. NONE gives no clamping.	Clamps input at specified value.  <b>ATTENTION:</b> Clamping is not recommended for process variable inputs to control loops.

Custom algorithm prompts

Table 4-7 describes the custom algorithm prompts. See Table 4-2 for additional prompts. These prompts appear only if CUSTOM INPUT is enabled under FEATURES. See Section 4.19.

**Table 4-7 Custom Algorithm Prompts**

Prompt	Range/Selections	Definition
INPUT SIGNAL	EMF, TC, or RTD.	Selects the input hardware
RJ ENABLE	Select Yes for reference junction compensation, NO for no compensation.	Reference junction compensation
EMISSIVITY ENABLE	Select Yes for emissivity compensation for emf input.	Emissivity compensation for emf input.
X <sub>n</sub>	<p>You must input at least 2 coordinates. X must increase by at least 0.00001. Y values are not limited except in the following 2 cases.</p> <p>1. If the incoming signal is from a thermocouple and reference junction compensation is on, make sure that a, b, and c are all true.</p> <p>a) All Y's are increasing or all are decreasing.</p> <p>b) Y range includes 0-65 °C.</p> <p>c) Temperature units are F, C, K, or R.</p> <p>2. If Online adjustment of the value is desired, make sure that all Y's are increasing or all are decreasing.</p>	<p>Use these prompts to plot a curve of up to 20 points, where X<sub>n</sub> is the incoming signal in the electrical units selected and Y<sub>n</sub> is its corresponding value in the temperature units selected. Interpolation is straight-line.</p>
Y <sub>n</sub>		
ELECTRICAL UNITS	MV, OHMS, VOLTS	Units of the electrical signal.
LAG	• 0 seconds or OFF	<p>LAG is a time constant applied to the input measurement value. This provides digital filtering (LAG) to the measurement.</p> <p>Lag appears on menu only if EXPANDED INPUT is enabled under Enable Features in the Program menu.</p>
SAMPLE HOLD	OFF, discrete parameter, 0, 1	<p>Holds Input. The input value is measured normally when this discrete is OFF (0) and holds its last value when the discrete is ON (1).</p> <p>Hold appears on menu only if EXPANDED INPUT is enabled under Enable Features in the Program menu.</p>

Press Menu when entries are complete. At the prompt "PRESS ENTER TO SAVE", press Enter to save your changes, or press Menu again to exit the session without saving the changes.



## 4.8 Program Control Loops

### Control Loop Programming Structure

Programming a control loop requires configuring at least 3 function blocks: an Analog Input (AI), a loop algorithm and an Analog Output (AO). The term AO is applied to any type of control output; current (CAT), voltage (VAT), or time proportioning (DAT). The structure of the instrument permits many variations on this concept by allowing Calculated Values (CVs), both digital and analog, to be used as inputs to the different parameters within the control algorithms. It also allows a single parameter to be read by any number of function blocks in the unit.

### Loop Characteristics

Table 4-8 lists loop characteristics to be aware of when configuring your instrument.

**Table 4-8 Loop Characteristics**

Characteristic	What to be aware of
Choice of algorithm type	Two PID algorithm types, interactive and noninteractive. Noninteractive is the default type; however, this may be changed.
Gain or proportional band	PB is the default; however this may be changed.
7 loop types available	If the loop type is changed after a configuration is completed, all previously programmed entries will be deleted.
Diagnostic routines	You will be prompted to save your entries when leaving the loop program sequence. Diagnostic routines are executed at this time to verify all entries are complete and compatible. A FAIL message at this time may indicate incomplete entries or incompatible selections.
Split output tuning	When programming Split Output control loops, tuning parameter set #1 is automatically applied to output values between 0 and +100. Tuning parameter set #2 is automatically applied to output values between 0 and -100.
Programming loop parameters	Control loop programming may require entry of numerical values, analog parameters or discrete parameters as determined by the specific loop feature. In some cases the choices may be a numeral, an analog parameter or OFF. For parameter choices, refer to Table 3-5 for definitions of the discrete and analog parameter types available. OFF or NONE are listed as menu choices where applicable. Scroll to locate.
Minimum programming requirements	Many of the prompted entry fields for control loops are optional. As a general rule, the minimum entry information for control loops includes the Process Variable (PV) with range limits, setpoint value, some combination of gain, reset and rate, and a source for the feedback. In most cases, the feedback source will be the back-calculation output (BC) value of the analog output (AO) function block.

**Table 4-8 Loop Characteristics (continued)**

Characteristic	What to be aware of
Split output programming requirements	<p>A splitter output type (Standard or Advanced) calculated value is used to send the Split loop output to 2 or 3 different analog output (AO) functions. In this case, program the control loop to receive a feedback from the back calculation output of the splitter calculated value. In other words, loop Feedback = CVn BC (where CVn is a Splitter type calculated value and BC is its output).</p> <p>Program the splitter calculated value to accept the back-calculation values (BC) of each analog output function block (AO) as its feedback source. In other words, CVn FB = AOn BC.</p>
Cascade primary loop	<p>Be sure to scale the cascade primary loop's output limits to match the process variable range of the secondary control loop. (Note: Output scaling is only available on the cascade primary type of control loop.) The primary loop feedback should be connected to the back calculation value of the secondary control loop.</p>
Miscellaneous loop characteristics	<p>Other parameters affecting loops are latching and reset limit. These are described in the loop prompt table.</p>

**Programming Procedure**

To program Control Loops, select "PROGRAM CONTROL LOOPS" in the Main Program Menu. Select a loop to program.

Table 4-9 illustrates the menu selections for the various loop types. See Table 4-10 for an alphabetical listing of these parameters' descriptions. Enter all desired choices, then repeat the procedure, if desired, for the other Loops.

**Table 4-9 Control Loop Type Menu Selections**

STD	ADV	SPLIT	ON OFF	CAS P	CAS S	RATIO	DIAT
IN DECIMAL POS	IN DECIMAL POS	IN DECIMAL POS	IN DECIMAL POS	IN DECIMAL POS	IN DECIMAL POS	IN DECIMAL POS	IN DECIMAL POS
OUT DECIMAL POS	OUT DECIMAL POS	OUT DECIMAL POS	OUT DECIMAL POS	OUT DECIMAL POS	OUT DECIMAL POS	OUT DECIMAL POS	OUT DECIMAL POS
PV	PV	PV	PV	OUT UNITS	PV	PV	PV
PV HIGH LIMIT	PV HIGH LIMIT	PV HIGH LIMIT	PV HIGH LIMIT	PV	PV HIGH LIMIT	PV HIGH LIMIT	PV HIGH LIMIT
PV LOW LIMIT	PV LOW LIMIT	PV LOW LIMIT	PV LOW LIMIT	PV HIGH LIMIT	PV LOW LIMIT	PV LOW LIMIT	PV LOW LIMIT
CONTROL ACTION	CONTROL ACTION	CONTROL ACTION	CONTROL ACTION	PV LOW LIMIT	CONTROL ACTION	CONTROL ACTION	CONTROL ACTION
GAIN/PROP BAND	GAIN/PROP BAND	GAIN/PROP BAND	SP1 TRACKING	CONTROL ACTION	GAIN/PROP BAND	GAIN/PROP BAND	GAIN/PROP BAND
PROP BAND#1/GAIN#1	PROP BAND#1/GAIN#1	PROP BAND#1/GAIN#1	SETPOINT#1	GAIN/PROP BAND	PROP BAND#1/GAIN#1	PROP BAND#1/GAIN#1	PROP BAND#1/GAIN#1
RESET#1	RESET#1	RESET#1	SETPOINT#2	PROP BAND#1/GAIN#1	RESET#1	RESET#1	RESET#1
RATE#1	RATE#1	RATE#1	SP INC SLEW LIMIT	RESET#1	RATE#1	RATE#1	RATE#1
PROP BAND#2/GAIN#2	PROP BAND#2/GAIN#2	PROP BAND#2/GAIN#2	SP DEC SLEW LIMIT	RATE#1	PROP BAND#2/GAIN#2	PROP BAND#2/GAIN#2	PROP BAND#2/GAIN#2
RESET#2	RESET#2	RESET#2	SP HIGH LIMIT	PROP BAND#2/GAIN#2	RESET#2	RESET#2	RESET#2
RATE#2	RATE#2	RATE#2	SP LOW LIMIT	RESET#2	RATE#2	RATE#2	RATE#2
MANUAL RESET	MANUAL RESET	MANUAL RESET	PV TRACKING	RATE#2	MANUAL RESET	MANUAL RESET	MANUAL RESET
SP1 TRACKING	APPROACH HIGH	APPROACH HIGH	HYSTERESIS	MANUAL RESET	SETPOINT#1	APPROACH HIGH	APPROACH HIGH
SETPOINT#1	APPROACH LOW	APPROACH LOW	MANUAL OFF	SP1 TRACKING	SETPOINT#2	APPROACH LOW	APPROACH LOW
SETPOINT#2	SP1 TRACKING	SP1 TRACKING	INTERACTIVE	SETPOINT#1	SP INC SLEW LIMIT	SP1 TRACKING	SP1 TRACKING
SP HIGH LIMIT	SETPOINT#1	SETPOINT #1	RESET LIMIT	SETPOINT#2	SP DEC SLEW LIMIT	SETPOINT #1	SETPOINT#1
SP LOW LIMIT	SETPOINT#2	SETPOINT #2	LATCHING	SP INC SLEW LIMIT	SP HIGH LIMIT	SP INC SLEW LIMIT	SETPOINT#2
SUPPRESS OVERTHOOT	SP INC SLEW LIMIT	SP INC SLEW LIMIT		SP DEC SLEW LIMIT	SP LOW LIMIT	SP DEC SLEW LIMIT	SP INC SLEW LIMIT
PV TRACKING	SP DEC SLEW LIMIT	SP DEC SLEW LIMIT		SP HIGH LIMIT	SOFT PID	SP HIGH LIMIT	SP DEC SLEW LIMIT
FEEDBACK	SP HIGH LIMIT	SP HIGH LIMIT		SP LOW LIMIT	FEEDBACK	SP LOW LIMIT	SP HIGH LIMIT
INTERACTIVE	SP LOW LIMIT	SP LOW LIMIT		SUPPRESS OVERTHOOT	FEEDFORWARD	RATIO SETPOINT	SP LOW LIMIT
RESET LIMIT	SUPPRESS OVERTHOOT	SUPPRESS OVERTHOOT		SOFT PID	FEEDFORWARD GAIN	RATIO BIAS	SUPPRESS OVERTHOOT
LATCHING	PV TRACKING	PV TRACKING		FEEDBACK	OUTPUT TRACKING	WILD VARIABLE	PV TRACKING
	SOFT PID	SOFT PID		FEEDFORWARD	FORCE REMOTE MAN	PV TRACKING	SOFT PID
	FEEDBACK	FEEDBACK					FEEDBACK

(continued)

**Table 4-9 Control Loop Type Menu Selections (continued)**

STD	ADV	SPLIT	ON OFF	CAS P	CAS S	RATIO	DIAT
	FEEDFORWARD	FEEDFORWARD		FEEDFORWARD GAIN	CHG ACTION INPUT	SOFT PID	FEEDFORWARD
	FEEDFORWARD GAIN	FEEDFORWARD GAIN		CHG ACTION INPUT	DUAL TUNING SEL	FEEDBACK	FEEDFORWARD GAIN
	OUTPUT TRACKING	OUTPUT TRACKING		DUAL TUNING SEL	DISCR VS KEY SEL	FEEDFORWARD	OUTPUT TRACKING
	FORCE REMOTE MAN	FORCE REMOTE MAN		DISCR VS KEY SEL	SETPOINT SELECT	FEEDFORWARD GAIN	FORCE REMOTE MAN
	CHG ACTION INPUT	CHG ACTION INPUT		SETPOINT SELECT	AUTO/MAN SELECT	OUTPUT TRACKING	CHG ACTION INPUT
	DUAL TUNING SEL	DUAL TUNING SEL		AUTO/MAN SELECT	INTERACTIVE	FORCE REMOTE MAN	DUAL TUNING SEL
	DISCR VS KEY SEL	DISCR VS KEY SEL		OUTPUT LOW LIMIT	RESET LIMIT	CHG ACTION INPUT	DISCR VS KEY SEL
	SETPOINT SELECT	SETPOINT SELECT		OUTPUT HIGH LIMIT	LATCHING	DUAL TUNING SEL	SETPOINT SELECT
	AUTO/MAN SELECT	AUTO/MAN SELECT		INTERACTIVE		DISCR VS KEY SEL	AUTO/MAN SELECT
	INTERACTIVE	INTERACTIVE		RESET LIMIT		SETPOINT SELECT	INTERACTIVE
	RESET LIMIT	RESET LIMIT		LATCHING		AUTO/MAN SELECT	RESET LIMIT
	LATCHING	LATCHING				INTERACTIVE	LATCHING
						RESET LIMIT	
						LATCHING	

**Loop Menu Items**

Table 4-10 alphabetically describes every loop menu item. See Table 4-2 for additional prompts.

**Table 4-10 Loop Prompts**

Prompt	Range/Selections	Definition
APPROACH HIGH	Enter a value 0.1 to 100 or OFF.	This function affects the process variable approach to setpoint when the process variable value is less than the setpoint value. The value entered is the percent of span deviation from setpoint at which a recalculation of the loop integral value will occur. Enter a starting value equal to the proportional band value (1/gain value) x 100 if Gain is used, or OFF at initial configuration. The value may be altered Online for final loop tuning. This function is useful for batch startup from a "cold" condition to control excessive overshoot when setpoint is reached.
APPROACH LOW	Enter a value 0.1 to 100 or OFF.	Affects the process variable approach to setpoint when the process variable value is greater than the setpoint value.
AUTO/MAN SELECT	OFF, discrete parameter, 0, 1	This parameter takes the place of the Auto/Man button when the DISCR VS KEY SEL discrete is ON (1).  AUTO/MAN SELECT = ON(1) = Manual mode  AUTO/MAN SELECT = OFF (0) = Automatic mode  When DISCR VS KEY SEL is OFF(0), AUTO/MAN SEL has no effect.
CHG ACTION INPUT	OFF, discrete parameter, 0, 1	Change Action Input. Selects the opposite control action from that selected for the control action (see CONTROL ACTION). Control action is opposite when the discrete value is ON or "1".
CONTROL ACTION	Reverse (REV) or Direct (DIR) Acting Control.	When Reverse Acting Control is selected, the loop output will increase as the process variable becomes less than setpoint, and will decrease as it becomes greater than the setpoint. When Direct Acting Control is selected, the output action is opposite.
DISCR VS KEY SEL	OFF, discrete parameter, 0, 1	Discrete vs. Keyboard select. When this discrete is ON (1), the Auto/Man and Setpoint buttons are disabled; their functioning is transferred to the AUTO/MAN SELECT and SETPOINT SELECT discrettes. See AUTO/MAN SELECT and SETPOINT SELECT. Status changes made by AUTO/MAN SELECT and SETPOINT SELECT will remain when DISCR VS KEY SEL is OFF (0).
DUAL TUNING SEL	OFF, discrete parameter, 0, 1	When ON(1), selects the second set of tuning constants (#2). A bumpless transfer (integral term adjusted) calculation will be made on transition.

**Table 4-10 Loop Prompts (continued)**

Prompt	Range/Selections	Definition
ENGINEERING UNITS	Select letter	Units of measure for values of process variable or setpoint which will appear on Online loop displays.
FEEDBACK	OFF, analog parameter, number	Provides verification to the loop that the loop output request (LP OV) was achieved by the analog output module (AO). Feedback sources are typically pointed to the associated Back Calculation Value (BC) of an analog output module. Feedback inputs must have a span equal to the loop output span when they are not pointed directly to analog output modules.
FEEDFORWARD	OFF, analog parameter, number	Modifies the control loop output independent of the PID calculation. The range of the value should not exceed 0 to 100 units. Feedforward is typically used to provide an output change in anticipation of a change to the loop process variable.
FEEDFORWARD GAIN	-10.00 to 10.00	Applies gain to the feedforward input value.
FORCE REMOTE MAN	OFF, discrete parameter, 0, 1	When discrete is ON (1), forces loop from automatic mode to remote manual mode. In remote manual, loop output is determined by the OUTPUT TRACKING value and the local Down Arrow and Up Arrow buttons for manual output adjustment are disabled. In remote manual the automatic indicator (AUTO) of the display will flash. Selecting Manual mode from the Auto/Manual button will override remote manual operation.  When the loop's Setpoint #2 is programmed as the Setpoint Profiler (SPn OV), Force Remote manual should be programmed as OFF.
GAIN/PROP BAND	PB or GAIN	Select whether gain or proportional band will be used for tuning the control loop.
GAIN#1 OR GAIN#2	Enter a value of 0.1 to 200 for Gain, or 0.5 to 1000.0 for Proportional Band. Enter OFF to allow integral only control. (Variable Gain1 or PB1 is available by programming a constant's Destination with GN or PB. See Program Constants, Section 4.16.)	Gain is the proportional gain entry for the control loop (The value entered here is the gain applied to the error signal to determine the loop output. For example, a 10 % change in process variable (with respect to the input range) from a balanced condition will result in a 10% change in output, when a gain of 1.0 is used. Enter a starting value at initial configuration. The value may be altered Online for final loop tuning. If an indirect source is specified as in an adaptive gain configuration, the value can only be altered at the source.  Gain and Proportional Band are interchangeable values (Proportional Band = 100/Gain). For loops with dual tuning, Gain 1 is the gain for the first set of tuning parameters. Gain 2 is for the second set.
HYSTERESIS	Enter 0-100 % of PV span	Deadband value prevents excessive output oscillation when using ON/OFF control.

**Table 4-10 Loop Prompts (continued)**

Prompt	Range/Selections	Definition
IN DECIMAL POSITION	Select decimal position	Used for all input parameters of the loop
INTERACTIVE	YES, NO	Select interactive (YES) or non-interactive (NO) for the control algorithm operation. Interactive causes the Gain, Rate, and Reset terms to interact to make up the proportional term of the algorithm (similar to analog controllers). In non-interactive the proportional term is simply related to Gain.
LATCHING	YES, NO	Select the desired action required after a failure to the failsafe status.  When the loop's PV or Setpoint #2 fails, the downstream function block activates its failsafe (See Table 9-10, Default condition column). If latching = YES, when the failure is corrected the operator must take specific action to cancel these failsafe measures and return the loop to normal operation. (See Table 9-10 for action needed.) If latching = NO, when the failure is corrected the loop will automatically return to normal operation with no action needed by the operator.
MANUAL OFF	OFF, discrete parameter, 0, 1	When this discrete input goes ON (1) it causes the control output to go off.
MANUAL RESET	-100 to +100	This feature functions only when OFF is entered for RESET. Enter a value equal to the desired loop output when the process variable is at setpoint. This allows correction of output to account for load changes to bring the process variable up to setpoint.
OUTPUT LOW LIM & OUTPUT HIGH LIM	OFF or number	For cascade primary loop, set to PV LOW LIMIT and PV HIGH LIMIT of the cascade secondary loop, respectively.
OUTPUT TRACKING	0-100%, Analog parameter, OFF	This will be the loop's output value when the FORCE REMOTE MAN input to the loop is high (1). See Force Remote Man.
PROCESS VARIABLE	OFF, analog parameter, number	Process variable for the loop.
PROP BAND#1 & PROP BAND#2		See GAIN#1 OR GAIN#2
PV LOW LIMIT & PV HIGH LIMIT	OFF or number	Enter the high and low limits for the process variable being controlled. Loop tuning parameters are based on the span selected by the high and low limit values.
PV TRACKING	PV, OFF	A selection of Process Variable (PV) will cause Setpoint #1 of the control loop to track the process variable when the loop is in Manual mode. A transfer to Automatic mode will maintain the tracked setpoint value as the working setpoint of the loop unless the loop was operating from Setpoint 2 prior to the transfer to Manual.

**Table 4-10 Loop Prompts (continued)**

Prompt	Range/Selections	Definition
RATE#1 & RATE#2	0.02-10.00 minutes	<p>Modifies the loop output based on the rate of change of the process variable. The output is modified by a value that assumes the rate of change of the process variable will continue for the time period specified. Enter a starting value or OFF at the time of configuration. The value may be altered Online for final loop tuning. For loops with dual tuning, Rate 1 is the rate for the first set of tuning parameters. Rate 2 is for the second set. (Variable Rate1 is available by programming a constant's Destination with RT. Program Constants, Section 4.16.)</p>
RESET#1 & RESET#2	0.005-99.99 repeats/minute	<p>Determines the period of time for a repeat of the proportional gain output. Enter a starting value at initial configuration. The value may be altered Online for final loop tuning. For loops with dual tuning, Reset 1 is the time for the first set of tuning parameters. Reset 2 is for the second set. (Variable Reset1 is available by programming a constant's Destination with RS. See Program Constants, Section 4.16.)</p> <p>A value of OFF may be entered to allow proportional-only control. When turned off, the manual reset value determines the loop output at setpoint. Bumpless manual to automatic transfer is canceled when proportional only control is selected.</p>
RESET LIMIT	OFF or 100 to 200 %.	<p>This value restricts the calculated integral value of the loop during Cold Start or on a manual-to-automatic transfer.</p>
RATIO BIAS		<p>Enter a bias value to be used in calculating the working set point of the ratio control loop. This is essentially a value that will be added to the product that results when RATIO SETPOINT is multiplied by the ratio loop's wild variable input value. For example, in the fuel-air ratio control scenario introduced in the RATIO SETPOINT section, suppose fuel flow is the wild variable that measured to be 60. With the RATIO SETPOINT prompt set to 0.5, the result will be 30 when the RATIO SETPOINT is multiplied by the fuel flow. If the RATIO BIAS prompt is then set to 10, the actual set point that the ratio loop will use to control air flow will be <math>30 + 10 = 40</math>.</p> <p>To make a ratio control loop's working set point equal to:</p> $(\text{RATIO SETPOINT} \times \text{Wild Variable value}) + \text{RATIO BIAS}$ <p>the loop's working set point must be toggled to SP2 using the "SP (Set Point select)" key while viewing the loop's ON LINE display. Refer to Figure 4-1.</p>



Table 4-10 Loop Prompts (continued)

Prompt	Range/Selections	Definition
RATIO SETPOINT		<p>Enter a number will equal the ratio that the ratio control loop will maintain between its process variable and a "wild variable." The wild variable may be the Output Value of any analog input or calculated value function block over which the ration loop will have no control</p> <p>The RATIO SETPOINT menu choice is essentially a multiplier applied to the wild variable's value. This multiplication's result will be a working set point for the loop that will ensure the desired "process variable-to-wild variable" ratio. For example, suppose you intend to use the ratio control loop to maintain a 50 % fuel-air ratio in the operation of a furnace. If the loop will be directly controlling air flow (i.e. - air flow will be the loop's process variable) and fuel flow will be used as a wild variable to generate the ratio loop's working set point, the RATIO SETPOINT menu choice will have to be set to 0.50. Hence, if fuel flow is measured to be 60, the working set point that will be used in the ratio loop's control of air flow will be <math>(60) \times (0.50) = 30</math>.</p> <p>To make a ratio control loop's working set point equal to the product of RATIO SETPOINT and a specific wild variable value, the loop's working set point must be toggled to SP2 using the "SP (Set Point Select)" key while viewing the loop's ON LINE display. Refer to Figure 4-1.</p>
SETPOINT SELECT	OFF, discrete parameter, 0, 1	<p>When the DISCR VS KEY SEL discrete is ON (1) this parameter takes the place of the On-Line Tune Loop menu's Toggle Setpoint Source prompt.</p> <p style="text-align: center;">SETPOINT SELECT = ON (1) = Setpoint2</p> <p style="text-align: center;">SETPOINT SELECT = OFF (0) = Setpoint1</p> <p>When DISCR VS KEY SEL is OFF (0), SETPOINT SELECT has no effect.</p>
SETPOINT#1 & SETPOINT#2	Setpoint #1 can be a number only. Setpoint #2 can be a number, an analog parameter, or OFF.	<p>Setpoint #1 and #2 are independent setpoints. Either may be the active setpoint for the loop. When viewing a live ON LINE mode control loop display, a loop may be switched between SETPOINT #1 and SETPOINT #2 by accessing the Tune Loop menu and selecting TOGGLE SETPOINT SOURCE. Operation of the loop using SETPOINT #1 will be indicated by the presence of an "SP1" symbol on the loop's display. "SP2" will be the symbol observed when the loop is operating using SETPOINT #2.</p> <p>While SETPOINT #2 may be programmed as a numerical value, it may also be used as a remote set point input to the loop. You may link SETPOINT #2 to any of several analog parameters that include the Output Values of analog input or calculated value function blocks. If used as a remote set point input, SETPOINT #2's value may not be manually changed from within any live ON LINE mode control loop displays.</p>

**Table 4-10 Loop Prompts (continued)**

Prompt	Range/Selections	Definition
SOFT PID	YES, NO	Soft PID action (YES) causes the control algorithm to not calculate proportional output corresponding to errors resulting from changes to setpoint. The algorithm will adjust its Reset (Integral) term to a value required to maintain the present output when the setpoint is changed. Normal proportional action should occur for all changes and variations to the controlled variable.
SP INC SLEW LIMIT & SP DEC SLEW LIMIT	Enter a number	Working setpoint slew limits for increasing and decreasing slew rates. (Variable slew limits are available by programming a constant's Destination with IS or DS. See Program Constants, Section 4.16.)
SP LOW LIMIT & SP HIGH LIMIT	OFF or number	Limits will be imposed on the working setpoint value, regardless of source. A setpoint value above or below the limits will be entered into the loop at the limit value. OFF entry will assume process variable limits. (Variable limits are available by programming a constant's Destination with HS or LS. See Program Constants, Section 4.16.)
SP1 TRACKING	SP2, NONE	A selection of Setpoint #2 will cause the Setpoint #1 value to be set to the Setpoint #2 value on a transfer from Setpoint #2 to Setpoint #1. Setpoint #1 adjustment may be made after the transfer.
SUPPRESS OVERTHOOT	YES, NO	This parameter set to YES limits overshoot of the Setpoint (SP) by the Process Variable (PV) after a disturbance in the process such as a load or SP change. Through fuzzy logic, the working SP of the control loop is dynamically modified by the control algorithm to reduce or eliminate overshoot.
<b>ATTENTION</b>		
Regardless of the setting of this SUPPRESS OVERTHOOT selection, overshoot is not suppressed when the process disturbance causes an initial deviation (PV-SP) value between -0.7 and +0.7 engineering units. Consequently, overshoot may not be suppressed in applications which require numerically small control loop PV ranges such as carbon potential where this range is typically 0.0 to 2.0 engineering units.		
WILD VARIABLE		Enter an analog input (AI <sub>n</sub> OV) or calculated value (CV <sub>n</sub> OV) parameter that represents a second input signal applied to the ratio control loop whose value will be multiplied by the RATIO SETPOINT multiplier. The product of this multiplication may be specified as the ratio control loop's working set point and can be biased by specifying a RATIO BIAS value. This input parameter is referred to as the "WILD VARIABLE" since the ratio loop has no control over its value whatsoever. In the fuel-air ratio control examples used in RATIO SETPOINT AND RATIO BIAS, fuel flow was for all intents and purposes the WILD VARIABLE.  Note that the typical function block diagram one will use to represent a ratio control loop is illustrated in Figure 4-1.

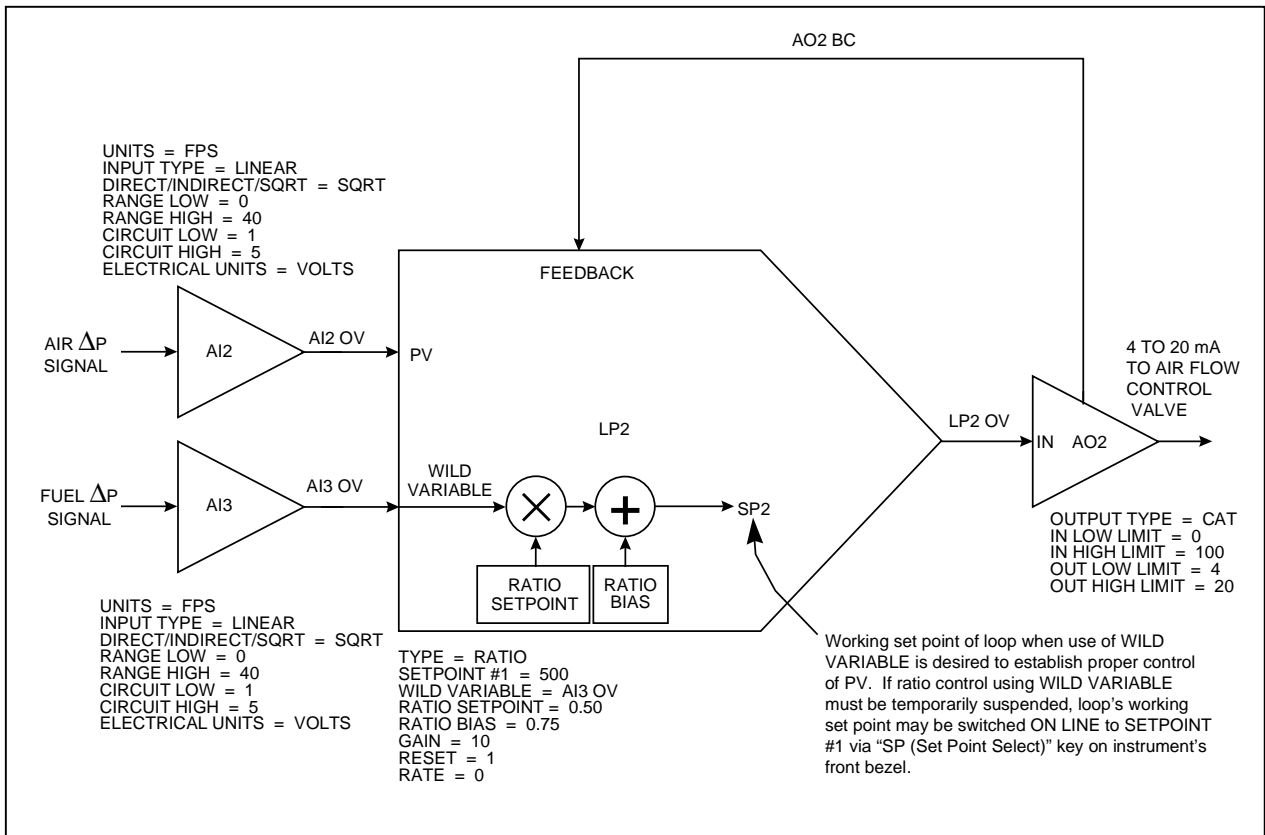


Figure 4-1 Function Block Configuration of a Typical Ratio Control Loop

When the ratio control loop in Figure 4-1 is brought ON LINE, its ON LINE display must be accessed to allow the instrument’s SP (Set Point Select) key to be operational. To make the working set point of the ratio control loop equal the equation

$$(WILD\ VARIABLE \times RATIO\ SETPOINT) + RATIO\ BIAS$$

you must select the TUNE LOOP menu item TOGGLE SETPOINT SOURCE so that an “SP2” is seen in the loop’s ON LINE display. Note that within the ratio control loop’s programming menu (accessed under PROGRAM CONTROL LOOPS), you will not find a SETPOINT #2 menu choice. The ratio control loop function block operates with the formula

$$(WILD\ VARIABLE \times RATIO\ SETPOINT) + RATIO\ BIAS$$

assuming all the functionality of the ratio loop’s second set point. Switching the working set point of a live ratio control loop from SP2 to SP1 will essentially suspend any ratio control and cause the loop to behave like a standard PID controller. This standard PID loop will have a local set point equal to the value programmed for SETPOINT #1. To control the process variable using a fixed set point that is independent of the loop’s WILD VARIABLE input, toggle the ratio control loop’s working set point to SP1.

## 4.9 Program Analog Outputs

Outputs 1– 3 are CAT or VAT types used for control and/or retransmission. Remaining outputs are DAT types used for control only. The relay outputs must be present to use these DAT outputs.

If the instrument will be used for control, program the loops first. See Program Control Loops in Section 4.8.

Select an analog output to program.

To change an analog output’s hardware from CAT to VAT, see Section 9.3.

### Analog output type

Select the output type from Table 4-11.

**Table 4-11 Analog Output Types**

ype as displayed	Full name of output type
CAT	Current Adjusting Type (Current output)
VAT	Voltage Adjusting Type (Voltage output)
DAT	Duration Adjusting Type (Time proportioning output)
POS_PROP	Position Proportion Type

Table 4-12 shows the prompts for each type of Analog Output.

**Table 4-12 Prompts For Analog Output Types**

CAT/VAT	DAT	POS_PROP
IN DECIMAL POS	IN DECIMAL POS	IN DECIMAL POS
OUT DECIMAL POS	INPUT SOURCE	INPUT SOURCE
INPUT SOURCE	INC SLEW LIMIT	SENSITIVITY
IN LOW LIMIT	DEC SLEW LIMIT	DRIVE UNIT SPEED
IN HIGH LIMIT	IMPULSE TIME	SLIDEWIRE INPUT
OUT LOW LIMIT	MIN ON TIME	POS ALGORITHM
OUT HIGH LIMIT	MIN OFF TIME	INC OUTPUT RELAY
INC SLEW LIMIT	FAILSAFE	DEC OUTPUT RELAY
DEC SLEW LIMIT	FAILSAFE VALUE	
FAILSAFE	OUTPUT RELAY	
FAILSAFE VALUE		

Table 4-13 describes each prompt.

**Table 4-13 Analog Output Prompts**

Prompt	Range/Selections	Definition
INPUT SOURCE	Enter OFF, analog parameter, number as the analog output source.	For a control loop, this is typically set to a control output (LP# OV). However, it may be directed to any analog value, such as a calculated value, to retransmit the value to an external device.
INPUT LOW LIMIT  INPUT HIGH LIMIT	If the AO's input source is a PID control loop, specify a high value of 100 and a low value of 0. For other input sources, specify limits using the same units as the AO's input source	Input limits. (Variable input limits are available by programming a constant's Destination with HS or LS. See Program Constants, Section 4.16.)
OUTPUT LOW LIMIT  OUTPUT HIGH LIMIT	For CAT, enter any output range within 0-20 mA. For VAT, enter any output range within 0-5V	These limits scale the output to the input limits.  CAT: A low limit of 4 and high limit of 20 will provide a 4-20 mA output range.  VAT: A low limit of 1 and a high limit of 5 will provide a 1-5 Vdc output range.
INC SLEW LIMIT  DEC SLEW LIMIT	Enter OFF or 0.1 to 999.9 units/minute (units of the AO's input source).	Limits the rate of increase or decrease of the analog output. Value entered is in terms of the AO's input source, not in terms of the output as defined by OUTPUT LOW LIMIT & OUTPUT HIGH LIMIT. (Variable slew limits are available by programming a constant's Destination with IS or DS. See Program Constants, Section 4.16.)
FAILSAFE	NONE UP (Upscale) DOWN (Downscale) VALUE	Select failure action to occur on input signal loss. If VALUE is selected, enter the value desired in FAILSAFE VALUE
FAILSAFE VALUE	Enter a value between Input Low Limit and Input High Limit or analog parameter or OFF	The value at which the output will be held for failsafe. This value is also the initial output of the loop on "cold start". If the value is set to OFF, the output will go to 0. Value entered is in terms of the AO's input source, not in terms of the output as defined by OUTPUT LOW LIMIT & OUTPUT HIGH LIMIT.
IMPULSE TIME	OFF or $\geq 1$	The cycle time (in seconds) for On and Off time of the output. For example, a time of 150 seconds will cause the output to be on for 75 seconds and off for 75 seconds when the input source is at 50 %. (Variable impulse time is available by programming a constant's Destination with IT. Program Constants, Section 4.16.)

**Table 4-13 Analog Output Prompts (continued)**

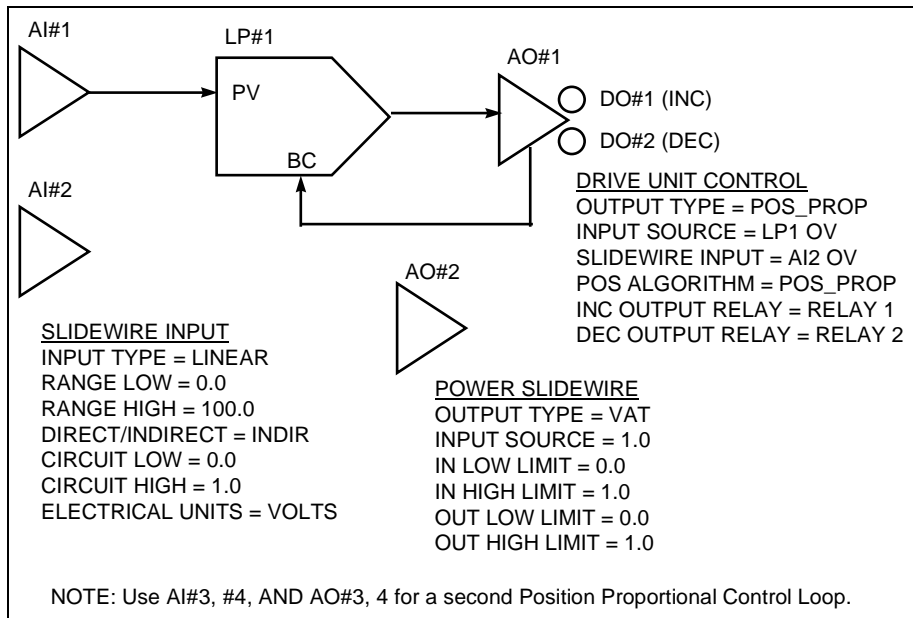
Prompt	Range/Selections	Definition
MIN ON TIME	OFF or $\geq 0$	<p>The minimum on time (in seconds) for the output. If the input source calls for the output to be on for less than this time, the output will not turn on at all.</p> <p><u>Example 1</u></p> <p>Impulse Time = 100. Min On Time = 5 seconds. The output will not come on unless the input source is <math>\geq 5\%</math>. For instance, if input source = 3%, output would be on for 3% of impulse time, or 3 seconds, but since 3 seconds is less than the Min On Time, output will not turn on.</p> <p><u>Example 2</u></p> <p>Impulse Time = 150. Min On Time = 3 seconds. The output will not come on unless the input source is <math>\geq 2\%</math>. For instance, if input source = 1%, output would be on for 1% of impulse time, or 1.5 seconds, but since 1.5 seconds is less than the Min On Time, output will not turn on.</p>
MIN OFF TIME	OFF or number	<p>The minimum off time (in seconds) for the output. If the input source calls for the output to be off for less than this time, the output will not turn off at all.</p> <p><u>Example 1</u></p> <p>Impulse Time = 100. Min Off Time = 5 seconds. The output will not turn off unless the input source is <math>\leq 95\%</math>. For instance, if input source = 98%, output would be off for 2% of impulse time, or 2 seconds, but since 2 seconds is less than Min Off Time, output will not turn off.</p> <p><u>Example 2</u></p> <p>Impulse Time = 150. Min Off Time = 3 seconds. The output will not turn off unless the input source is <math>\leq 98\%</math>. For instance, if input source = 99%, output would be off for 1% of impulse time, or 1.5 seconds, but since 1.5 seconds is less than the Min Off Time, output will not turn off.</p>
OUTPUT RELAY	Select discrete output channel.	This is the discrete output channel if using DAT output algorithm. This discrete output will be unprogrammable under the PROGRAM DISCRETE OUTPUTS programming menu.
SENSITIVITY	NUMBER, OFF	Enter the largest value that does not cause drive motor oscillation.
DRIVE UNIT SPEED	NUMBER, OFF	The full scale travel time for the motor.
SLIDEWIRE INPUT	OFF, NUMBER, PARM	<p>The AI block associated with the hardware input connected to the slidewire (typically AI2).</p> <p>The range of the feedback analog input must be programmed for engineering units of 0 to 100 units, indirect range, with a circuit span of 0 to 1 Vdc.</p>

**Table 4-13 Analog Output Prompts (continued)**

Prompt	Range/Selections	Definition
POS ALGORITHM	POS_PROP, DIAT, AUTO	<p><b>Positioning Algorithm</b> – Specify the appropriate algorithm. The rules are:</p> <ul style="list-style-type: none"> <li>• AUTO and DIAT algorithm can be used only with DIAT loop type.</li> <li>• PP algorithm can be used only with loop types <u>other than DIAT</u>.</li> <li>• PP and AUTO algorithms require a feedback analog input.</li> </ul> <p>AUTO permits normal feedback positioning of the drive motor when the feedback input is good, and defaults to DIAT operation if the slidewire feedback input fails.</p>
INC OUTPUT RELAY	OFF, RELAY 1... RELAY 24	This is the increasing discrete output channel for the POS_PROP or DIAT positioning algorithms.
DEC OUTPUT RELAY	OFF, RELAY 1... RELAY 24	This is the decreasing discrete output channel for the POS_PROP or DIAT positioning algorithms.

**ATTENTION**

ON/OFF loop types provides direct output without the use of an analog output. To complete an ON/OFF loop configuration, assign the ON/OFF loop's output (LPn OS) to a Discrete Output Relay (see Program Discrete Outputs, section 4.11).



**Figure 4-2 Function Block Configuration of a Position Proportional Function Block for One Position Proportional Control Loop**

## 4.10 Program Discrete Inputs

Discrete Input function blocks are controlled by the on/off status of the input hardware. The output of the function block, DIn OS, reflects the status of the associated input hardware. This output DIn OS can be connected to other function blocks' input parameters to trigger actions such as starting a profile or selecting a control loop's Setpoint #1 or Setpoint #2, among many other possibilities.

The Program Discrete Input menu item will appear if an optional DI/DO card is installed.

Select a discrete input to program, then program the prompts in Table 4-14. See Table 4-2 for additional prompts.

**Table 4-14 Discrete Input Prompts**

Prompt	Range/Selections	Definition
ACTION STATE	NORMAL, INVERT	Determines whether the input will be normally closed or normally open when ON(1). To select closed when ON (1), enter NORMAL (not inverted). To select closed when OFF(0), enter INVERT (inverted).
DELAY TIME	Number of seconds	When the DI is placed in its ON(1) state, the DI function will wait for the specified delay time before indicating the ON(1) condition as an output. If the DI "ON" state changes before the delay time expires, no ON output will be indicated.
EVENT ENABLE	NONE, RISING, FALLING, BOTH	Determines whether changes in DI's status can be recorded as events in data storage.  NONE - status changes are not stored RISING - OFF(0)-to-ON(1) changes can be stored FALLING - ON(1)-to-OFF(0) changes can be stored BOTH - Both changes can be stored

### ATTENTION

To change to 16 DI's and 16 DO's or to 8 DI's and 24 DO's, see Section 9.4.



## 4.11 Program Discrete Outputs

Discrete Output function blocks control the relay or open collector output hardware. The Program Discrete Outputs menu item will appear if the optional Discrete Outputs are installed.

### ATTENTION

If a discrete output has been assigned to a time proportioning output (DAT), it will not be programmable here. See "OUTPUT RELAY" in Table 4-13.

Select a DO to program, then program the prompts in Table 4-15. See Table 4-2 for additional prompts.

**Table 4-15 Discrete Output Prompts**

Prompt	Range/Selections	Definition
ACTION STATE	NORMAL, INVERT	Determines whether the relay will normally be energized or de-energized when the DO's Input is ON(1). To select <i>energized when ON</i> , enter NORMAL (not inverted). To select <i>energized when OFF</i> , enter INVERT (inverted).
INPUT	OFF, discrete parameter, 0, 1	Source of the Discrete Output.
EVENT ENABLE	NONE, RISING, FALLING, BOTH	Determines whether changes in DO's status can be recorded as events in data storage. For storage to occur, Data Storage must also be programmed to store Events.  NONE - status changes are not stored RISING - OFF(0)-to-ON(1) changes can be stored FALLING - ON(1)-to-OFF(0) changes can be stored BOTH - Rising and falling changes can be stored

### ATTENTION

To change to 16 DI's and 16 DO's or to 8 DI's and 24 DO's, see Section 9.4.

## 4.12 Program Calculated Values

A Calculated Value (CV) is a data point whose value is derived from calculations involving other data points. The CV Output can be analog or discrete. A CV can include other CVs in its calculations. Once a CV is created, it can be used by any function block as many times as desired.

Select "CALCULATED VALUES" on the Main Program Menu. Select a CV to program, then choose from the types shown in Table 4-16.

### ATTENTION

- If you plan to program another function block using a Calculated Value as a parameter, you must program the Calculated Value first.
- Once you change the type and press Enter, the previous type's settings are deleted and cannot be recovered.

Table 4-16 CV Types

Type	Math Package	Description	Page
NONE		No CV Programmed	--
PEAK PICKING	2	Picks maximum input value	107
SIGNAL SELECT	1	Selects signal per your criteria	108
COMPARE	1	Compares input and outputs result	109
COUNTER	1	Counts transitions of input status	113
MATH	S	Calculates math on 8 inputs using one operator	114
FREE FORM MATH	S	Calculates math on 8 inputs using several operators	115
LOGIC	S	Outputs logic of inputs	117
FREE FORM LOGIC	S	Outputs logic of inputs using custom equation	119
INVERTER	S	Inverts status of input	121
BCD	S	Binary Coded Decimal conversion	122
FUNCTION GENERATOR	2	Generates custom $y = f(x)$ curve	124
INTERVAL TIMER	1	Counts time in minutes	126
PERIODIC TIMER	1	Generates periodic pulse	127
MASS FLOW	2	Calculates mass flow with square root	129
CARBON POTENTIAL	2	Generates a %C value	130
RELATIVE HUMIDITY	1	Calculates relative humidity	131
STERILIZATION	2	Calculates $F_0$ Sterilization	133
ADV SPLITTER	2	Splits input into 3 outputs	134
STD SPLITTER	1	Splits input into 2 outputs	136
SCALING	1	Scales input to output	137
SIGNAL CLAMP	1	Clamps input to specified values	138
1 PT BLOCK AVG	2	Averages one input	139
ROLLING AVG	2	Computes rolling average of one input	140
MULTIPLE AVG	2	Averages multiple inputs	141
CEM BLOCK AVG	2	Averages one input over specified intervals	142
CEM ROLLING AVG	2	Computes rolling average of one input over specified intervals	143
S: Standard Math package 1: VPR: Math Level 1 package (includes Standard Math package) 2: VPR: Math Level 2 package (includes Standard Math and Math Level 1 packages) VRX100/150: Advanced Math package			

Refer to the page shown for the desired CV programming procedures. Press Enter when the "PRESS ENTER TO SAVE" prompt appears to save your entries made during the session.

**Peak Picking**

This type monitors the input and determines a “peak” value reached during the specified time interval (in minutes). The peak can be chosen to be a maximum, minimum, average, or standard deviation. At the end of the time interval, the output CVn OV steps to the value of the peak and holds this value until the end of the next time interval. If the Reset Input turns ON(1), the output is held and the time interval restarts.

Table 4-17 describes the Peak Picking prompts. See Table 4-2 for additional prompts.

**Table 4-17 Peak Picking Prompts**

Prompt	Range/Selections	Definition
RANGE LOW	OFF or number	Enter the output's display limits. Output is not clamped or flashed when it exceeds these limits.
RANGE HIGH		
INPUT	OFF, analog parameter, number	Input source whose peak is picked
RESET	OFF, discrete parameter, 0, 1	Holds output and restarts time interval
ACTION	NONE, MIN, MAX, AVG, STDDEV	Type of peak pick. MIN selects the minimum, MAX selects the maximum, AVG selects the mean average, STDDEV selects the standard deviation over the time interval.
PERIOD MINUTES	0-999,999.9	Number of minutes in time interval

**Signal Select**

Selects one of eight inputs based on the action and outputs it as CVn OV.

Table 4-18 describes the Signal Select prompts. See Table 4-2 for additional prompts.

**Table 4-18 Signal Select Prompts**

Prompt	Range/Selections	Definition
OUTPUT LOW LIMIT	OFF or number	Displayed output value will be clamped and will flash when these limits are exceeded.
OUTPUT HIGH LIMIT		
INPUT #1 - INPUT #8	OFF, analog parameter, number	Up to 8 input sources to be selected from according to the ACTION.
ACTION	HIGH	Selects the highest valued input.
	LOW	Selects the lowest value input.
	AVG	Averages the input values.
	MIDDLE	Selects the middle (median) input value. If the number of inputs is even, selects the sum of the middle two input values divided by 2.
	F-GOOD	(First Good) If inputs fail, selects the first good input to the function block. For example, if inputs 1 and 2 fail, then input 3 is selected.
	ANA-SW	(Analog Switch) Selects an input equal to the value of the ANALOG SELECT parameter.
	DIS-SW	(Discrete Switch) Selects Input #1 or #2 according to state of DISCRETE SELECT.
ANALOG SELECT	OFF, analog parameter, number	Example: if ASEL=3, then Input #3 is selected. If ANALOG SELECT < 1, Input #1 is selected. The value of ANALOG SELECT is truncated to a whole number. For example, if ANALOG SELECT is 3.55, the value is truncated to 3 and Input #3 is selected.
DISCRETE SELECT	OFF, discrete parameter, 0, 1	Selects Input #1 when DISCRETE SELECT is off (0); selects Input #2 when DISCRETE SELECT is ON (1). Inputs 3-8 are unused.

## Compare

Compare can be used instead of an Alarm's output to control a relay. It can also provide on/off control with hysteresis.

Compares 2 inputs. Call the result of this comparison "Result". Result is a pulse that goes ON(1) when comparison is true, and OFF(0) when comparison is not true. If hysteresis is given a value, then Result will not go OFF(0) until hysteresis value is exceeded. Result is then processed according to the specified condition type and condition time. The final output is a discrete pulse CVn OS.

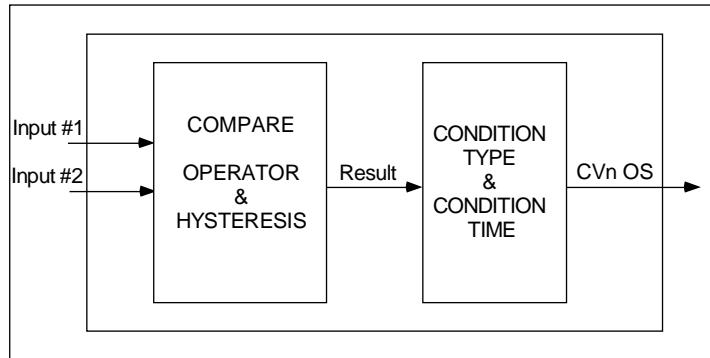


Figure 4-3 Compare Signal Flow

Table 4-19 and Table 4-20 describe the Compare prompts. See Table 4-2 for additional prompts.

Table 4-19 Compare Prompts

Prompt	Range/Selections	Definition
INPUT #1	OFF, analog parameter, number	Input sources to be compared.
INPUT #2		
OPERATOR	EQ, GT, LT, GTE, LTE, NEQ	The Result will be set to ON(1) when the comparison is true: Input #1 OPERATOR Input #2 where OPERATOR is: EQ(=), GT(>), LT(<), GTE (≥), LTE (≤), NEQ(≠) The Result will be set to OFF(0) when the comparison is false.
HYSTERESIS	Number, OFF	Applies to all operators except EQ and NEQ. If given a value, hysteresis determines when Result goes OFF(0) after the comparison becomes false. <u>Operator</u> <u>Hysteresis Function</u> GT:            Result goes OFF when Input #2 - Input #1 ≥ Hyst GTE:          Result goes OFF when Input #2 - Input #1 > Hyst LT:            Result goes OFF when Input #1 - Input #2 ≥ Hyst LTE:          Result goes OFF when Input #1 - Input #2 > Hyst See Figure 4-4.
CONDITION TYPE	NONE, DELAY, EXTEND, PULSE, RT PULSE	See Table 4-20.
CONDITION TIME	OFF or number	Enter number of seconds of condition time. See Table 4-20.

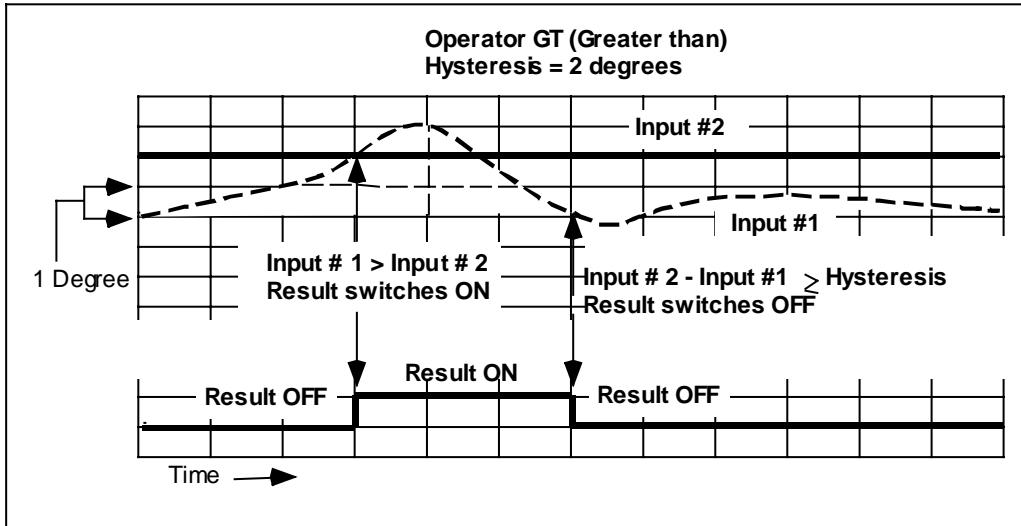
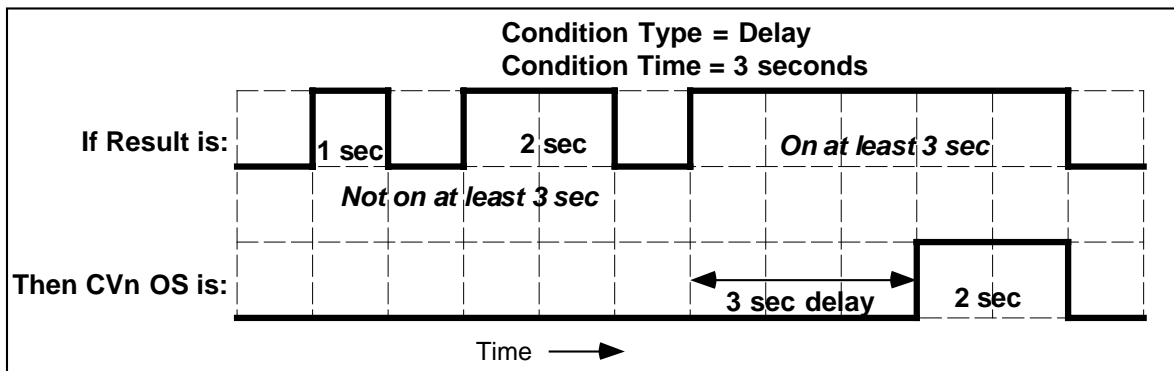


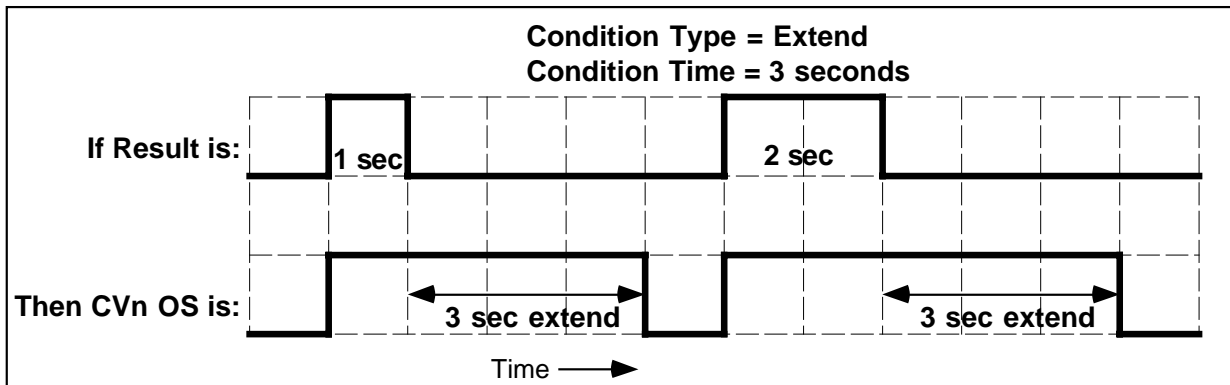
Figure 4-4 Compare's Greater Than Result, With Hysteresis

**Table 4-20 Compare's Condition Type and Condition Time Prompts**

Condition type	Application	If this is true	then CVn OS is
NONE	--	Result	Result
Condition type	Application	If this is true	then CVn OS is
DELAY	Filters short pulses Delays rising edge of Result for CONDITION TIME	Result switches ON(1) for n seconds $\geq$ CONDITION TIME.	ON n seconds minus CONDITION TIME
		Result switches OFF(0)	OFF(0)

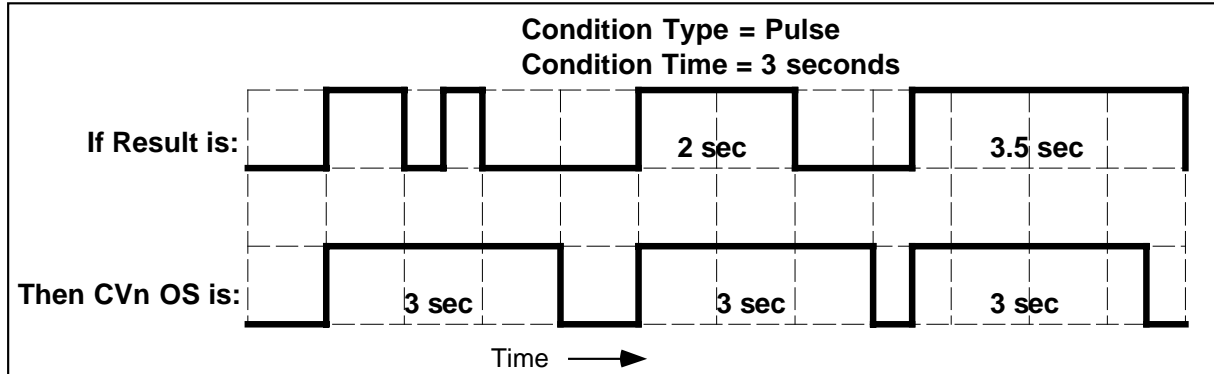


Condition type	Application	If this is true	then CVn OS is
EXTEND	Used for interfacing with slower circuits.	Result switches ON(1) for n seconds, then OFF(0)	ON(1) for n seconds plus CONDITION TIME, then OFF(0)
	Extends falling edge of Result for CONDITION TIME.	Result switches ON(1)	ON with no delay

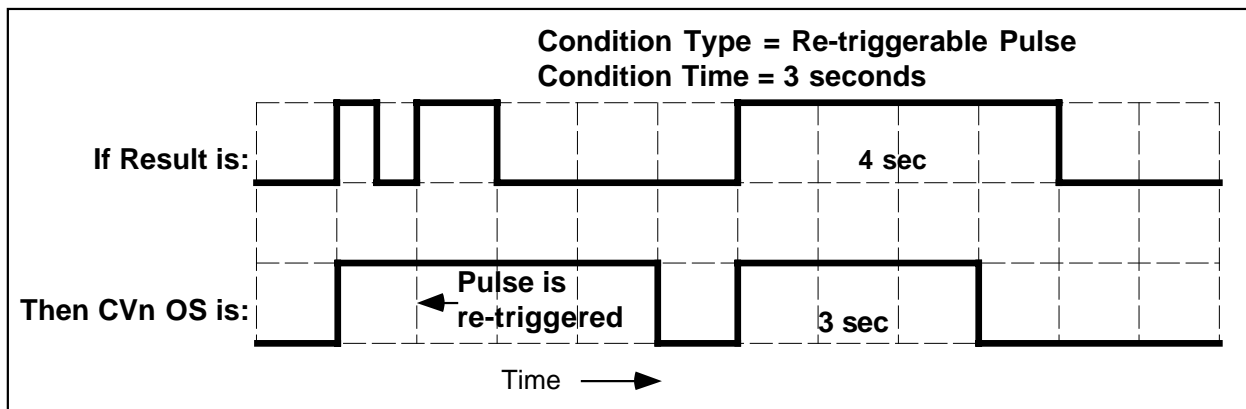


**Table 4-20 Compare's Condition Type and Condition Time Prompts (continued)**

Condition type	Application	If this is true	then CVn OS is
PULSE	Used for interfacing with slower circuits. On rising edge of Result, creates pulse length CONDITION TIME and ignores additional rising edges of Result within that CONDITION TIME.	Result switches ON(1) for $\leq$ CONDITION TIME, then OFF(0).	ON(1) for CONDITION TIME, then OFF(0). During CONDITION TIME, any additional OFF(0)-to-ONs of Result are ignored.



Condition type	Application	If this is true	then CVn OS is
RT PULSE (Re-triggerable pulse)	Used for slower circuits.  Guarantees that CVn OS will be ON for CONDITION TIME after most recent rising edge of Result.	Result switches ON(1) for $\leq$ CONDITION TIME, then OFF(0)	ON(1) for CONDITION TIME, then OFF(0).
		Result switches ON(1) multiple times before CONDITION TIME expires	ON(1) when Result first switches ON(1) and remains ON(1) until Result has not switched ON(1) for CONDITION TIME.
		Result switches ON(1) for $\geq$ CONDITION TIME, then OFF(0)	ON(1) for CONDITION TIME then OFF(0).





**Counter**

Counts the number of OFF(0)-to-ON(1) transitions of the input. This number is output as CVn OV. When this number reaches the Preset value, a discrete output parameter CVn OS goes ON(1) until Reset occurs.

Table 4-21 describes the Counter prompts. See Table 4-2 for additional prompts.

**Table 4-21 Counter Prompts**

Prompt	Range/Selections	Definition
RANGE LOW	OFF or number	Enter the output's trend display limits. Output is not clamped or flashed when it exceeds these limits.
RANGE HIGH		
INPUT	OFF, discrete parameter, 0, 1	Input source.
RESET	OFF, discrete parameter, 0, 1	When Reset is level high, output state (OS) is ON and the counter resets to zero if counting up or to the Preset value if counting down from it. When Reset is level low, counter resumes counting.
PRESET	OFF, analog parameter, number	The number of input transitions after which the CVn OS output will go ON(1). To count forever, set to OFF. If OFF, CVn OS will not be triggered.
COUNT DOWN	YES or NO	Select NO to count up from zero to the Preset value; YES to count down from the Preset value to zero. If Preset is OFF, Count Down must be NO.

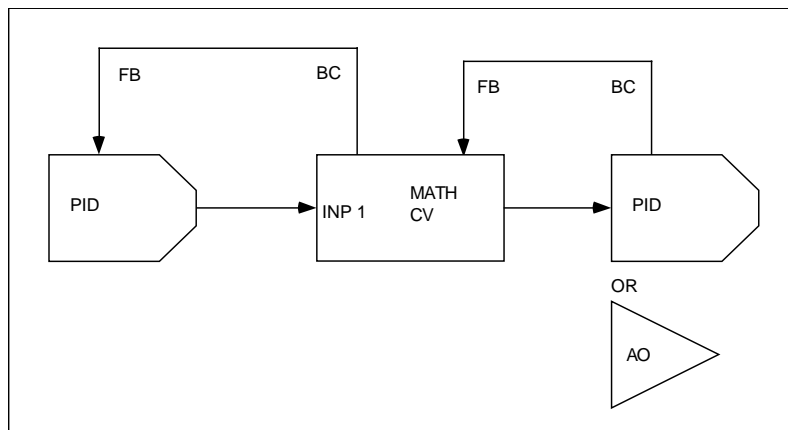
**Math**

Performs math on up to 8 inputs using a single operator. Output is CVn OV. Division by 0 is indicated by CVn OV's displayed value flashing 0.

Table 4-22 describes the Math prompts. See Table 4-2 for additional prompts.

**Table 4-22 Math Prompts**

Prompt	Range/Selections	Definition
INPUT A - INPUT H	OFF, analog parameter, number. If connecting to an upstream loop, that loop output (LP# OV) MUST be INPUT A (see Feedback).	Enter up to 8 input sources.
OUTPUT LOW LIMIT	Enter limits	Displayed output value will be clamped and will flash when these limits are exceeded.
OUTPUT HIGH LIMIT		
OPERATOR	ADD, SUBT, MULT, DIV, ABSVAL, SQRT and STDDEV.	1. Input1 OPERATOR Input2 OPERATOR...Input8 where OPERATOR is one of these: add, subtract, multiply, or standard deviation (Standard Deviation uses all inputs.) Example: Input1 minus Input2 minus ...Input8. 2. OPERATOR Input1 where OPERATOR is absolute value or square root. 3. Input1 OPERATOR Input2 where OPERATOR is divide. Note: Inputs 3-8 are not used in division.
FEEDBACK	OFF, analog parameter, number	Select LP# BC or AO# BC to propagate the back calculation (BC) value from a downstream loop or AO. Also, program the upstream loop's feedback with this Math CV's back calculation value (CV# BC). You MUST program this CV's feedback to NONE if this CV is not used as part of a control loop output configuration (Figure 4-5). If it is part of a loop configuration, the math operator cannot be ABSVAL, SQRT, or STDDEV.



**Figure 4-5 Math CV Feedback Programming**

**Free Form Math**

The output CVn OV is the result of a user-specified equation. QWERTY keyboard may be used for easier equation entry.

Table 4-23 describes the Free Form Math prompts. See Table 4-2 for additional prompts.

**Table 4-23 Free Form Math Prompts**

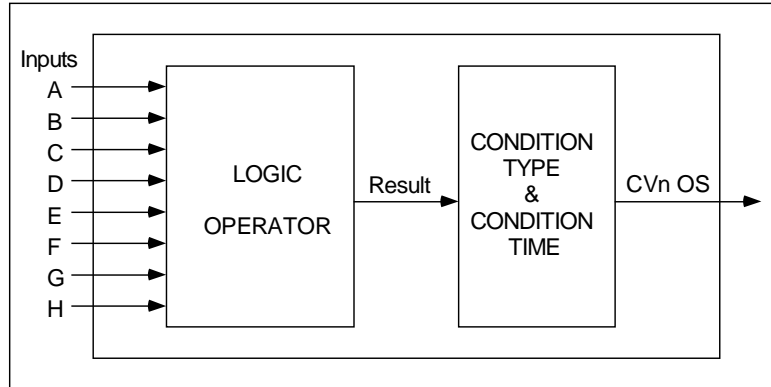
Prompt	Range/Selections	Definition
OUT LOW LIMIT	OFF or number	Displayed output value will be clamped and will flash when these limits are exceeded.
OUT HIGH LIMIT		
EQ	See Table 4-24.	<ul style="list-style-type: none"> <li>• Enter the equation using the QWERTY keyboard.</li> <li>• See Table 4-24 for allowable characters and functions.</li> <li>• Enter up to 64 characters (upper or lower case)</li> <li>• Spaces are permitted.</li> <li>• Enclose a function's argument with parentheses ().</li> <li>• Square root argument must be absolute value to prevent square root of a negative value.</li> <li>• Only whole numbers may be used as exponents.</li> </ul> <p>Example: To input this equation</p> $CN\ 5\ OV \times 12 \sqrt{\frac{AI\ 1\ OV}{AI\ 2\ OV}} + 5$ <p>enter these settings:</p> <p>INPUT A: CN5OV            INPUT B: 12.0            INPUT C: AI1OV            INPUT D: AI2OV            EQ: A*B*SQRT (ABS(C/D))+5</p> <p>Note how constants can be entered through the Constant function block (as in example's Input A), assigned to an input (as in example's Input B), or entered directly in the equation (as in example with 5).</p>
INPUT A - INPUT H	OFF, analog parameter, number	Enter the parameters or numbers to be used in the equation.
RESET	OFF, discrete parameter, 0, 1	Resets the function block. Use only when the equation result is the input to itself (integrating); that is, when the equation contains the letter O.

**Table 4-24 Free Form Math Functions**

For this function or value	Type this in the equation
$n$ (constant)	$n$
Negation ( $-n$ )	NEG( $n$ )
Value of Input A	A
Value of Input B	B
Value of Input C	C
Value of Input D	D
Value of Input E	E
Value of Input F	F
Value of Input G	G
Value of Input H	H
Add	+
Subtract	-
Multiply	*
Divide	/
Constant number	$n$ (for example, 123.45)
Absolute value of $n$	ABS( $n$ )
Square root of $n$	SQRT( $n$ )
$y^n$	$y^n$
$e^x$ where $x=n$	EX( $n$ )
Log base 10 of $n$	LOG( $n$ )
Natural log of $n$	LN( $n$ )
Integration: Result of equation as of last machine cycle	O (Letter 'O', not zero '0'.)

**Logic**

The input or inputs are processed by a logic operator. Call the result of this logic operation “Result”. Result is a pulse that goes ON(1) when the logic is true, and OFF(0) when the logic is not true. Result is then processed according to the specified condition type and condition time. The final output is a discrete pulse CVn OS. See Figure 4-6.



**Figure 4-6 Logic Signal Flow**

Table 4-25 describes the Logic prompts. See Table 4-2 for additional prompts.

**Table 4-25 Logic Prompts**

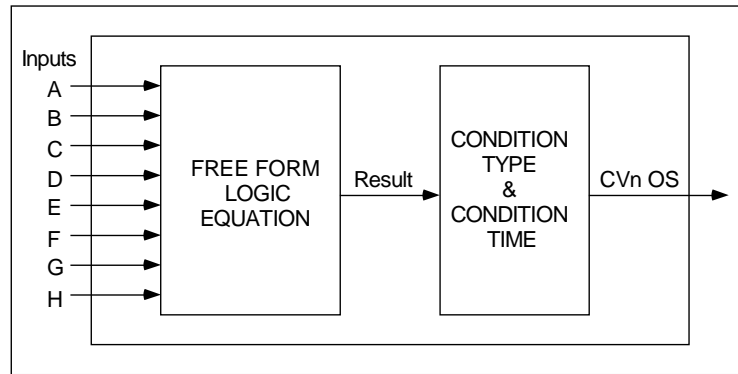
Prompt	Range/Selections	Definition
OPERATOR	AND, OR, XOR, RESET/SET FF, TOGGLE/FF, ONE SHOT, PASS	See Table 4-26.
INPUT A	OFF, discrete parameter, 0, 1.	Program at least 2 inputs. Only inputs programmed with parameter, 1, or 0 are processed with the operator.
INPUT B		
INPUT C		
INPUT D		
INPUT E		
INPUT F		
INPUT G		
INPUT H		
CONDITION TYPE	NONE, DELAY, EXTEND, PULSE, RT PULSE	See Table 4-20 on page 111.
CONDITION TIME	OFF or number	Enter number of seconds of condition time. See Table 4-20 on page 111.

**Table 4-26 Logic Operators**

For this operator	Definition	if this is true	then Result is
AND	If all programmed inputs are ON, Result is ON.	All programmed inputs are ON(1)	ON(1)
OR	If at least 1 programmed input is ON, Result is ON.	At least 1 programmed input is ON(1)	ON(1)
XOR	Uses Inputs A and B only.	Input A is ON(1) and Input B is OFF(0).	ON(1)
	If one and only one input is ON, Result is ON.	Input A is OFF(0) and Input B is ON (1).	ON(1)
RESET/SET FF (Reset/Set Flip-Flop)	Rising edge of Input A turns Result ON.	Input A is ON(1).	ON(1)
	Rising edge of Input B resets Result.	Input A is OFF(0) and Input B is ON (1).	OFF(0)
TOGGLE/FF	Toggle Flip-Flop. Rising edge of Input A inverts Result	Input A changes from OFF(0) to ON(1) (rising edge)	ON(1) if it was OFF(0), or OFF(0) if it was ON(1).
		Input A changes from ON(1) to OFF(0) (falling edge)	unchanged
ONE SHOT	Rising edge of Input A turns Result ON for one machine scan cycle.	Input A is ON(1) for any length of time	ON(1) for 1 scan cycle of the instrument, then OFF(0)
PASS	Passes Input A's state unchanged to CONDITION TYPE.	Input A changes state	same as Input A

**Free Form Logic**

Lets you enter up to 64 characters as a custom logic equation (EQ) containing inputs and logical operators. The result of this equation is called “Result”. Result is then processed according to the specified condition type and condition time. The final output is CVn OS. See Figure 4-7.



**Figure 4-7 Free Form Logic Signal Flow**

Table 4-27 describes the Free Form Logic prompts. See Table 4-2 for additional prompts.

**Table 4-27 Free Form Logic Prompts**

Prompt	Range/Selections	Definition
EQ	*	Symbol for AND operator
	+	Symbol for OR operator
	^	Symbol for XOR operator
	NEG	Symbol for NOT operator
	A, B, C, D, E, F, G, H	Symbols for Input A through Input H
	O	Letter O is the symbol for output CVn OS from the previous logic calculation. Use for iterative calculations.
	1	One = ON
	0	Zero = OFF
	( )	Expressions enclosed by parentheses are evaluated first.
INPUT A - INPUT H	OFF, discrete parameter, 0, 1.	Up to 8 input sources.
RESET	OFF, discrete parameter, 0, 1	Resets the output to OFF (0). Use when using the letter O in equations.
CONDITION TYPE	NONE, DELAY, EXTEND, PULSE, RT PULSE	See Table 4-20 on page 111.
CONDITION TIME	OFF or number	Enter number of seconds of condition time. See Table 4-20 on page 111.

**Order of evaluation**

1. Parentheses ()
2. NOT
3. AND
4. OR, XOR

**Example equation using operators and inputs**

$(A+B)*C$  computes the result of (A OR B) AND C.

**Table 4-28 (A OR B) AND C**

A	B	C	Result
0	0	0	0
0	0	1	0
0	1	0	0
0	1	1	1
1	0	0	0
1	0	1	1
1	1	0	0
1	1	1	1

**Example equation using iteration**

The equation  $A+B*O$  computes the result of:

(Input A OR Input B from current machine cycle) AND (Input A OR Input B from previous machine cycle).

Table 4-29 shows some possible results of this equation.

**Table 4-29 Results of Logic Equation Using Iteration**

[Input A (current) OR	Input B (current)] AND	[Input A (previous) OR	Input B (previous)]	= Result
1	1	1	1	1
1	0	1	0	1
0	0	1	0	0
1	0	0	0	0



**Inverter**

The output CVn OS is the logical inverse of the input parameter.

Table 4-30 describes the Inverter prompts. See Table 4-2 for additional prompts.

**Table 4-30 Inverter Prompts**

Prompt	Range/Selections	Definition
INPUT	OFF, discrete parameter, 0, 1	Input source to be inverted.

**BCD**

Converts up to 8 discrete inputs' binary coded decimal into an unsigned integer and output the integer as CVn OV. For example, 00000100 = 4.

On the VPR, when the enable is triggered, the setpoint program specified by the value of CVn OV is copied from internal storage to the Profile function block(s) where the profile(s) can be programmed or executed.

Table 4-31 describes the BCD prompts. See Table 4-2 for additional prompts.

**Table 4-31 BCD Prompts**

Prompt	Range/Selections	Definition
OUT LOW LIMIT	OFF or number	Displayed output value will be clamped and will flash when these limits are exceeded.
OUT HIGH LIMIT		
BIT 0 through BIT 7	OFF, discrete parameter, 0, 1	The binary coded decimal represented by the states of these discretes will be converted into an unsigned integer. BIT 7 is the most significant bit and BIT 0 is the least significant bit.
ENABLE	OFF, discrete parameter, 0, 1	On the VPR, when this discrete transitions from off(0) to on(1), the specified program's profile(s) will be loaded from internal memory to the Profile function block(s). See Table 4-32.

**VPR Example #1, loading a 2-profile program**

You are programming a 2-programmer instrument. According to Table 4-32, a 2-programmer instrument can run 2 profiles at a time and can store in its internal memory up to 6 programs, each containing 2 profiles.

Suppose the BCD bits are programmed as follows: Bit 2 = 1, Bit 1 = 1, Bit 0 = 0. This sequence of bits equals the number 6 and is the value of CVn OV. When the Enable discrete is triggered ON(1), the profiles in Program #6 will be loaded from internal memory into the function blocks for Profile #1 and Profile #2, where they can be edited or run.

**VPR Example #2, loading a 4-profile program**

You are programming a 4-programmer instrument. According to Table 4-32, a 4-programmer instrument can run 4 profiles at a time and can store in its internal memory up to 3 programs, each containing 4 profiles.

Suppose the BCD bits are programmed as follows: Bit 2 = 0, Bit 1 = 1, Bit 0 = 0. This sequence of bits equals the number 2 and is the value of CVn OV. When the Enable discrete is triggered ON(1), the profiles in Program #2 will be loaded from internal memory into the function blocks for Profiles #1 through #4, where they can be edited or run.

Table 4-32 How Profiles Are Saved In Memory (VPR only)

1-programmer instrument 1 Profile per Program		2-programmer instrument 2 Profiles per Program		3-programmer instrument 3 Profiles per Program		4-programmer instrument 4 Profiles per Program	
This Program...	...contains this Profile	This Program...	...contains these Profiles	This Program...	...contains these Profiles	This Program...	...contains these Profiles
1	1	1	1	1	1	1	1
2	1		2				
3	1	2	1	2	3	1	3
4	1		2				
5	1	3	1	3	2	2	1
6	1		2				
7	1	4	1	3	1	3	3
8	1		2				
9	1	5	1	4	3	3	1
10	1		2				
11	1	6	1	4	2	3	3
12	1		2				
•		•		•		•	
•		•		•		•	
•		•		•		•	
93	1	47	1	32	1	24	1
94	1		2				
95	1	48	1	32	2	24	3
96	1		2				

### Function Generator

This CV type can be used to characterize a valve (Figure 4-9) or an input signal (Figure 4-10). You enter a custom curve of up to 19 segments (20 X,Y coordinates). The input is compared with the X values and its corresponding Y value becomes the output CVn OV. Interpolation between coordinates is straight line. See Figure 4-8.

If the input value is outside the range of X values, the nearest X value is used, the output will be clamped to the corresponding Y value and the displayed output value will flash.

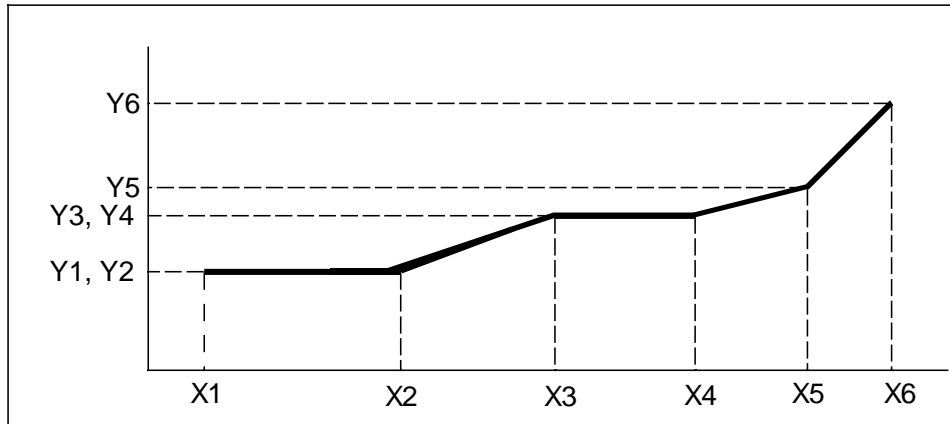


Figure 4-8 Function Generator Curve

Table 4-33 describes the Function Generator prompts. See Table 4-2 for additional prompts.

Table 4-33 Function Generator Prompts

Prompt	Range/Selections	Definition
RANGE LOW	OFF or number	Enter the output's lower display limit. Output is not clamped or flashed when it exceeds this limit. Default value is Y1 value.
RANGE HIGH	OFF or number	Enter the output's lower display limit. Output is not clamped or flashed when it exceeds this limit. Default value is Y1 value.
INPUT	OFF, analog parameter, number	This value will be compared with the X values of the curve. The corresponding Y value will be the CV output.
X1, Y1, X2, Y2...X20, Y20	OFF or number	Use these prompts to plot a curve using 2 to 20 X,Y coordinates. X values must increase as Xn increases.
FEEDBACK	OFF, analog parameter, number	For valve characterization, select AO# BC to propagate the back calculation (BC) value from a downstream Analog Output. Also, program the upstream loop's feedback with this CV's back calculation value (CV# BC). See Figure 4-9.  <b>Attention:</b> If feedback is programmed to an analog parameter or a number, the X and Y values must define a curve that is not bell shaped or complex. That is, all Y values must be increasing or decreasing.

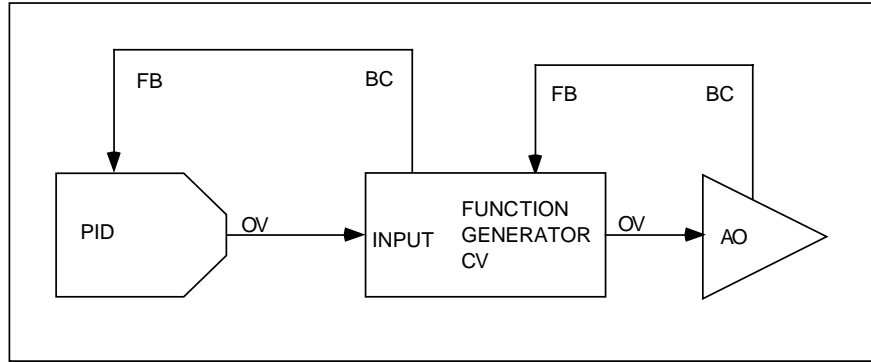


Figure 4-9 Function Generator Configuration For Valve Characterization

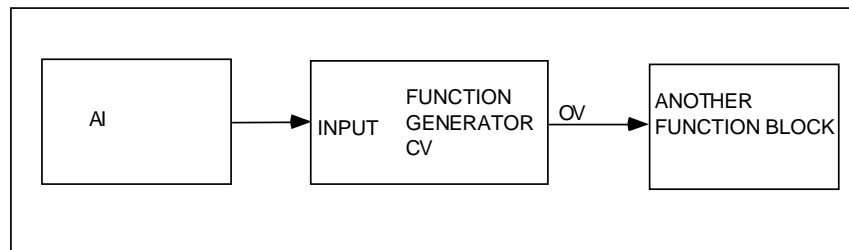


Figure 4-10 Function Generator Configuration For Input Signal Characterization

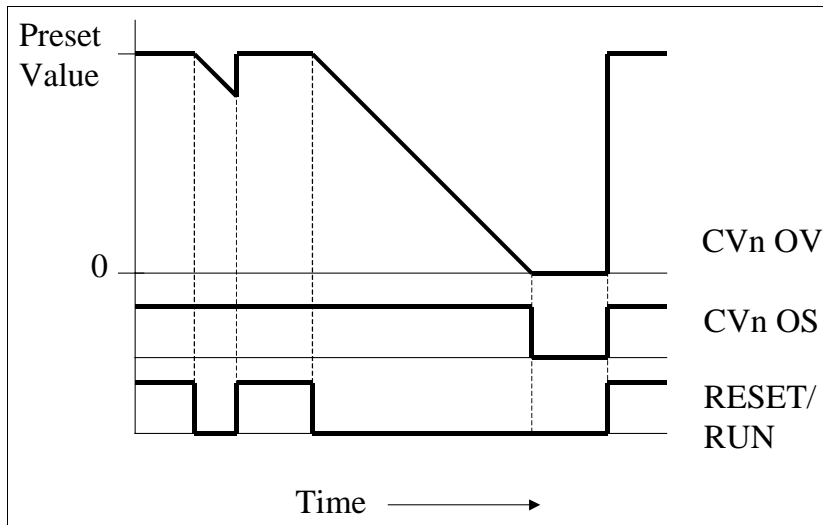
**Interval Timer**

This timer counts down from the preset value in minutes. This time remaining is CVn OV. The timer has a single discrete output CVn OS which is ON(1) when the timer is actively counting or when RESET/RUN is ON(1). CVn OS is OFF(0) when the timer has timed out to zero. An OFF-to-ON transition of RESET/RUN resets the timer to the preset value and turns CVn OS on; an ON-to-OFF transition starts the timer.

Table 4-34 describes the Interval Timer prompts. See Table 4-2 for additional prompts.

**Table 4-34 Interval Timer Prompts**

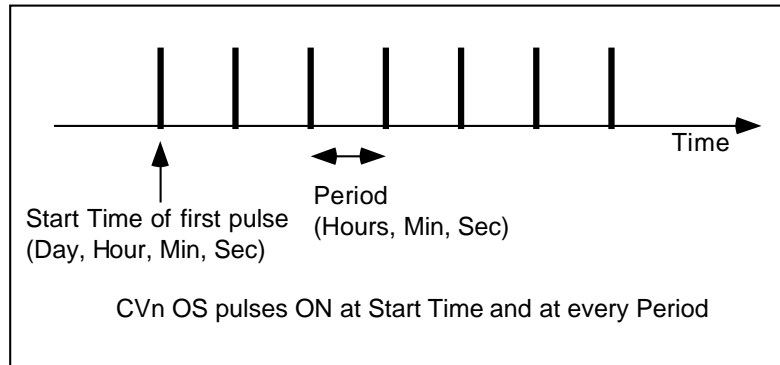
Prompt	Range/Selections	Definition
PRESET	OFF, analog parameter, number	Timer counts to zero from this number of minutes.
RESET/RUN	OFF, discrete parameter, 0, 1	Controls the operation of the timer. See description above.
RANGE LOW	OFF or number	Enter the output's display limits. Output is not clamped or flashed when it exceeds these limits.
RANGE HIGH		



**Figure 4-11 Interval Timer**

**Periodic Timer**

Generates a discrete output pulse CVn OS which is ON(1) for 1 machine cycle (250ms, 500ms, 1 sec) at specified Start time and repeated at a specified Period thereafter. Use this to activate a discrete parameter at a particular time and at regular intervals.



**Figure 4-12 Periodic Timer**

Table 4-35 describes the Periodic Timer prompts. See Table 4-2 for additional prompts.

**Table 4-35 Periodic Timer Prompts**

Prompt	Range/Selections	Definition
SET UP TIMER	See Table 4-36 for prompts	Selects the timer format.

**Table 4-36 Set Up Timer Prompts**

Prompt	Range/Selections	Definition
PHASE	NONE, DAILY, WEEKLY, MONTHLY	Select the timer format. Remaining prompts will vary per phase selected.
PERIOD HOURS	0-23	Number of hours in the period
PERIOD MINUTES	0-59	Number of minutes in the period
PERIOD SECONDS	0-59	Number of seconds in the period
RESET	OFF, discrete parameter, 0, 1	Phase NONE only. When this discrete is ON(1), timer stops and resets to beginning of period. When discrete is OFF(0), timer begins again.
START DAY	MONDAY, TUESDAY...SUNDAY	For Phase WEEKLY, select the day of the week to start the timer.
	1-31	For Phase MONTHLY, select the day of the month to start the timer. If this number exceeds the number of days in any given month, then the discrete switches ON(1) the last day of that month.
START HOURS	0-23	Hours of the Start time.
START MINUTES	0-59	Minutes of the Start time.
START SECONDS	0-59	Seconds of the Start time.

**ATTENTION**

The Start Time's value cannot exceed the Period. An error message is displayed if you enter a Start Time of 8:00:00 and a Period of 4:00:00, for example.

---



**Mass Flow**

By compensating for variations in fluid temperature and pressure, Mass Flow is used to obtain a more precise fluid flow measurement from an orifice plate developing a differential pressure. The output CVn OV is mass flow and is calculated from the following formula for U.S. Units Of Measurement:

$$MF = \text{FACTOR 1} \times \text{SQRT} [DP \text{ INPUT} \times (\text{PRESSURE INPUT} + 14.7) / (\text{TEMPERATURE INPUT} + 459)]$$

where

FACTOR 1 is calculated by user

DP INPUT is differential pressure in inches of water

PRESSURE INPUT is in PSIG

TEMPERATURE INPUT is in °F

Or, Mass flow is calculated from the following formula for International Units Of Measurement:

$$MF = \text{FACTOR 1} \times .569 \times \text{SQRT} [DP \text{ INPUT} \times (\text{PRESSURE INPUT} + 101.4) / (\text{TEMPERATURE INPUT} + 273)]$$

where

FACTOR 1 is calculated by user

DP INPUT is differential pressure in KPASCALS

PRESSURE INPUT is in KPASCALS

TEMPERATURE INPUT is in °C

Table 4-37 describes the Mass Flow prompts. See Table 4-2 for additional prompts.

**Table 4-37 Mass Flow Prompts**

Prompt	Range/Selections	Definition
OUT LOW LIMIT	OFF or number	Displayed output value will be clamped and will flash when these limits are exceeded.
OUT HIGH LIMIT		
DP INPUT	OFF, analog parameter, number	Differential pressure input
PRESSURE INPUT	OFF, analog parameter, number	Pressure input in PSIG or KPASCALS
TEMP INPUT	OFF, analog parameter, number	Temperature in C or F.
UNITS OF MEASURE	US or International	Units of measure
FACTOR 1	OFF, analog parameter, number	Flow factor for the particular installation

**Carbon Potential**

The Carbon Potential Control Function Block provides for weight percent (wt%) control of carbon in carburizing, hardening, and atmosphere generating applications.

**Table 4-38 Carbon Prompts**

Prompt	Range/Selections	Definition
PROBE TYPE	NONE, AACP, SUPER SYS, MARATHON, FCC	Selection which represents the manufacturer of the oxygen probe being used. This determines which linearization equations are used for %C and dewpoint calculations.
CARBON PROBE IN	NUMBER, PARM, OFF	Analog input that is connected to the oxygen probe mV output.
PROBE TEMP INPUT	NUMBER, PARM, OFF	Analog input that is connected to the oxygen probe temperature output.
TEMPERATURE UNIT	NONE, F, C, K, R	Temperature scale for this block. This selection must match the temperature scale of the analog input that is connected to the oxygen probe temperature output.
TEMP LOW LIMIT	NUMBER, OFF	Probe temperature value below which this block's low temperature discrete output (OS) is turned ON. This limit and subsequent discrete output may be used to force the control loop's output to a known value when the probe temperature is too low for carbon potential control.
CO COMPENSATION	NUMBER, PARM, OFF	Number used in the %C calculation which represents the %CO present in the endothermic gas.
FURNACE FACTOR	NUMBER, PARM, OFF	Correction factor used to account for environmental variation within the furnace chamber. In units of %C, this factor is added directly to the %C value calculated from probe output linearization.
SOOTING FACTOR	ON, OFF	Boolean value that determines whether the anti-sooting factor output (A1) will be based linearly on probe temperature (SOOTING FACTOR=ON) or a constant value of 2.0 (SOOTING FACTOR=OFF). If SOOTING FACTOR is ON, a probe temperature of 1408 °F or below limits %C output to 0.75% and 2086 °F or above limits %C output to 2.0%.
PERCENTAGE HYDROGEN	NUMBER, OFF	Number representing %H <sub>2</sub> that is used in the dewpoint calculation.

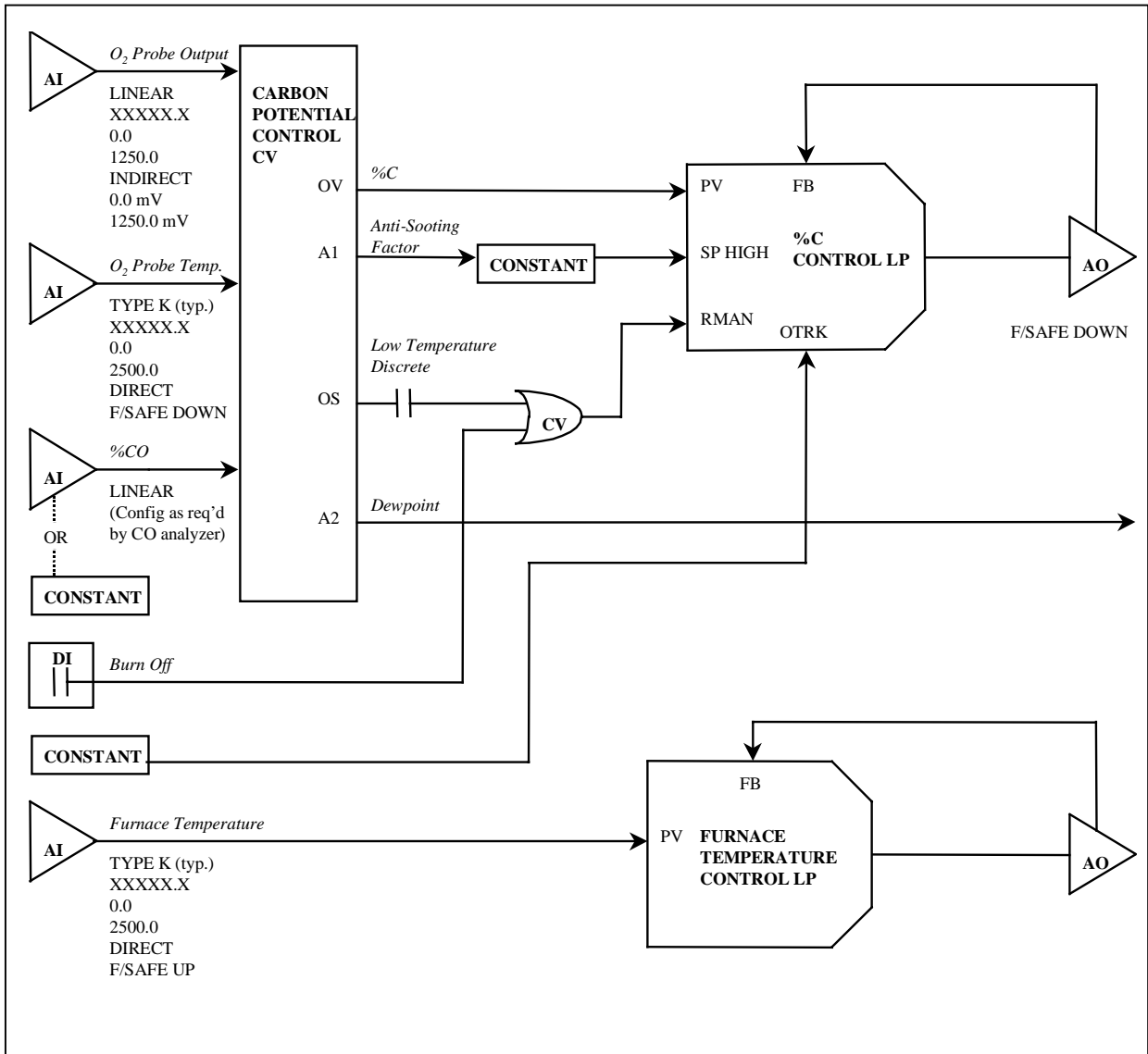


Figure 4-13 Typical Carbon Potential Control Configuration

**Relative Humidity**

Outputs CVn OV relative humidity as a function of dry-bulb temperature, wet-bulb temperature, and atmospheric pressure.

Table 4-39 describes the Relative Humidity prompts. See Table 4-2 for additional prompts.

**Table 4-39 Relative Humidity Prompts**

Prompt	Range/Selections	Definition
RANGE LOW	OFF or number	Enter the output's display limits. Output is not clamped or flashed when it exceeds these limits.
RANGE HIGH		
DRY BULB TEMP	OFF, analog parameter, number	Dry bulb temperature in temperature units selected.
WET BULB TEMP	OFF, analog parameter, number	Wet bulb temperature in temperature units selected.
ATM PRESS (PA)	OFF, analog parameter, number	Enter atmospheric pressure in Pascals. 101325 Pa. Is one standard atmosphere
TEMPERATURE UNITS	F, C, K, R	Select the temperature units for the calculation. Units are for wet bulb and dry bulb.

### Sterilization

The output CVn OV is a “kill time”,  $F_0$ , which quantifies the destruction of microorganisms during a sterilization process.  $F_0$  represents the number of minutes after which the microorganism population is decreased by one decimal or log unit. The  $F_0$  formula is:

$$F_0 = \sum [dt \times (10^{(T-T_{ref})/Z})]$$

where:

$dt$  = time between  $F_0$  measurements, in minutes.  $Dt$  is equal to the scan cycle of the instrument in minutes.

$T$  = measured temperature input, in °C

$T_{ref}$  = reference temperature (121 °C typical)

$Z$  = product-dependent temperature constant

This function also compares the calculated  $F_0$  value to the desired  $F_0$  value,  $F_d$  (Preset). When  $F_0$  equals or exceeds  $F_d$ , the function activates its discrete output CVn OS; this output remains ON (1) until the  $F_0$  calculation is reset via the Reset Input.

The output CVn A2 is the Time Remaining ( $Tr$ ) at the current temperature to achieve  $F_d$  and is calculated as follows:

$$Tr = \frac{(F_d - F_0)}{10^{(T-T_{ref})/Z}}$$

The  $F_0$  calculation will be reset and the  $F_0$  value will remain at zero while the Reset Input is ON (1). The calculation will resume when the Reset Input goes OFF (0) again.

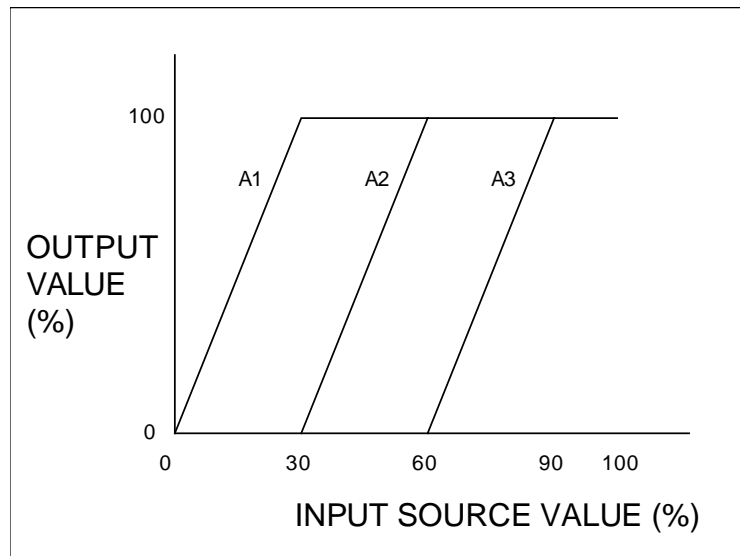
Table 4-40 describes the Sterilization prompts. See Table 4-2 for additional prompts.

**Table 4-40  $F_0$  Sterilization Prompts**

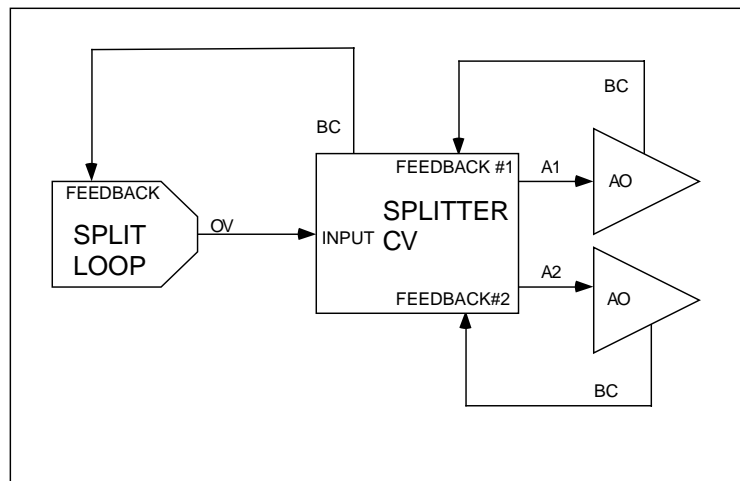
Prompt	Range/Selections	Definition
OUT LOW LIMIT	OFF or number	Displayed output value will be clamped and will flash when these limits are exceeded.
OUT HIGH LIMIT		
RESET	OFF, discrete parameter, 0, 1	Reset input
TEMP INPUT	OFF, analog parameter, number	Measured temperature in degrees C
REFERENCE TEMP	OFF, analog parameter, number	Reference temperature
TEMP CONSTANT	OFF, analog parameter, number	Temperature constant Z
DESIRED F0	OFF, analog parameter, number	Desired $F_0$ ( $F_d$ )

**Advanced Splitter Output (ADV SPLITTER)**

This function can be used for heat/cool applications. It splits an input into 3 independently scaled outputs: CV<sub>n</sub>\_A1, CV<sub>n</sub>\_A2 and CV<sub>n</sub>\_A3 (Figure 4-14). For each output, when the input is between IN LO LIM and IN HI LIM, the output is scaled between the OUT LO LIM and OUT HI LIM. Each output holds its OUT LO LIM value when the input < the IN LO LIM value for that output. Each output holds its OUT HI LIM value when the input > the IN HI LIM value for that output. Output limits (OUT LO LIM & OUT HI LIM) cannot exceed 100% but can be negatively sloped (OUT HI LIM < OUT LO LIM).



**Figure 4-14 Advanced Splitter (Default Outputs)**



**Figure 4-15 Heat/Cool Configuration**

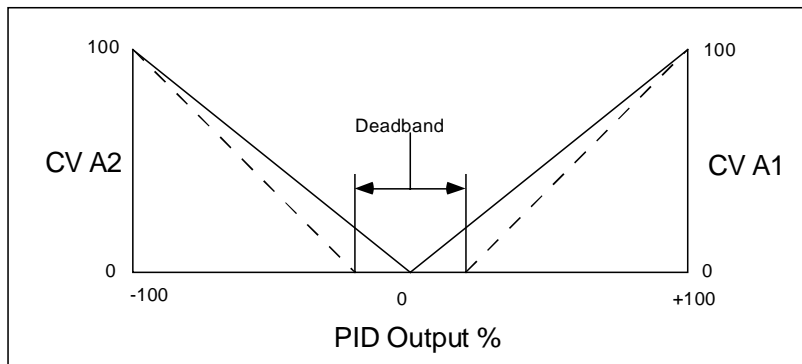
Table 4-41 describes the Advanced Splitter prompts. See Table 4-2 for additional prompts.

**Table 4-41 Advanced Splitter Prompts**

Prompt	Range/Selections	Definition
RANGE LOW	OFF or number	Enter the output's display limits. Output is not clamped or flashed when it exceeds these limits.
RANGE HIGH		
INPUT	OFF, analog parameter, number	Input source. Typically, this is the output value (OV) of a Split Output type of loop.
FEEDBACK #1	OFF, Aon BC, LPn BC	Select the back calculation value (BC) of the analog output assigned to the A1, A2, and A3 outputs, respectively.
FEEDBACK #2		
FEEDBACK #3		
OUT#1 IN LO LIM	OFF or number	Enter a range for A1's input. Defaults are 0 for low limit & 30 for high limit. When input is between these values, A1 output is scaled between OUT#1 OUT LO LIM & OUT#1 OUT HI LIM.
OUT#1 IN HI LIM		
OUT#1 OUT LO LIM	OFF or number	Enter OFF or a range for A1's output. Defaults are 0 for low limit & 100 for high limit. Scales A1 output.
OUT#1 OUT HI LIM		
OUT#2 IN LO LIM	OFF or number	Enter a range for A2's input. Defaults are 30 for low limit & 60 for high limit. When input is between these values, A2 output is scaled between OUT#2 OUT LO LIM & OUT#2 OUT HI LIM.
OUT#2 IN HI LIM		
OUT#2 OUT LO LIM	OFF or number	Enter OFF or a range for A2's output. Defaults are 0 for low limit & 100 for high limit. Scales A2 output.
OUT#2 OUT HI LIM		
OUT#3 IN LO LIM	OFF or number	Enter a range for A3's input. Defaults are 60 for low limit & 90 for high limit. When input is between these values, A3 output is scaled between OUT#3 OUT LO LIM & OUT#3 OUT HI LIM.
OUT#3 IN HI LIM		
OUT#3 OUT LO LIM	OFF or number	Enter OFF or a range for A3's output. Defaults are 0 for low limit & 100 for high limit. Scales A3 output.
OUT#3 OUT HI LIM		

**Standard Splitter Output (STD SPLITTER)**

This function can be used for heat/cool applications. It is a deadband-based splitter that divides a Split loop's output (-100% to +100%) into two outputs CVn A1 and CVn A2, both of which are zero when the loop output is zero (Figure 4-16). A deadband provides a range of loop output within which both split outputs remain at zero. For overlapped outputs, use Advanced Splitter. Note: A third output CVnA3 is displayed Online and should be ignored.



**Figure 4-16 Standard Split Output Function**

Table 4-42 describes the Standard Splitter prompts. See Table 4-2 for additional prompts.

**Table 4-42 Standard Splitter Prompts**

Prompt	Range/Selections	Definition
RANGE LOW	OFF or number	Enter the output's display limits. Output is not clamped or flashed when it exceeds these limits.
RANGE HIGH		
INPUT	OFF, analog parameter, number	Input source. Typically, this is the output value (OV) of a Split Output type of loop.
FEEDBACK #1	Aon BC, LPn BC, CVn BC	Enter an AO, LP or CV for the back calculation value (BC) of the analog output assigned to the A1 output.
FEEDBACK #2	Aon BC, LPn BC, CVn BC	Enter an AO, LP or CV for the back calculation value (BC) of the analog output assigned to the A2 output.
OUTPUT DEADBAND	OFF or number	Deadband up to 10% of the input span. In this range, both split outputs will remain at zero.



**Scaling**

The output CVn OV is a linear scaling of the input using the specified limits.

Table 4-43 describes the Scaling prompts. See Table 4-2 for additional prompts.

**Table 4-43 Scaling Prompts**

Prompt	Range/Selections	Definition
IN LOW LIMIT	OFF or number	Enter limits of input to be scaled
IN HIGH LIMIT		
RANGE LOW	OFF or number	Enter the output's scaling values and display limits. Output is not clamped or flashed when it exceeds these limits.
RANGE HIGH		
INPUT	OFF, analog parameter, number	Input to be scaled according to the limits

### Signal Clamp

If input is between Low Select and High Select, the output CVn OV equals the input. If the input exceeds these two limits, the output equals the preset value.

Table 4-44 describes the Signal Clamp prompts. See Table 4-2 for additional prompts.

**Table 4-44 Signal Clamp Prompts**

Prompt	Range/Selections	Definition
OUT LOW LIMIT	OFF or number	Displayed output value will be clamped and will flash when these limits are exceeded.
OUT HIGH LIMIT		
LOW SELECT	OFF, analog parameter, number	If input goes below this number, the output will equal the preset value. Otherwise, the output equals the input.
HIGH SELECT	OFF, analog parameter, number.	If input goes above this number, the output will equal the preset value. Otherwise, the output equals the input
INPUT	OFF, analog parameter, number	Input to be clamped
PRESET	OFF, analog parameter, number.	Output will go to this value when the input exceeds the low or high select values.

**1 Point Block Average (1 Pt Block Avg)**

Outputs a block mean average CVn OV of the input over the specified Average Period. A new sample of the input will be taken on every instrument scan cycle. The block average is only updated at the end of the Average Period.

When the Reset Input is ON(1) all accumulated samples are discarded and the output is held until the Reset Input is OFF(0), then the averaging period resets.

Table 4-45 describes the 1 Point Block Average prompts. See Table 4-2 for additional prompts.

**Table 4-45 1 Point Block Average Prompts**

Prompt	Range/Selections	Definition
RANGE LOW	OFF or number	Enter the output's display limits. Output is not clamped or flashed when it exceeds these limits.
RANGE HIGH		
INPUT	OFF, analog parameter, number	This parameter will be averaged
RESET	OFF, discrete parameter, 0, 1	When the Reset is ON(1) all accumulated samples are discarded and the output is held until the Reset is OFF(0), then the averaging period resets.
AVERAGE PERIOD	0.1 to 1440	Length of averaging period in minutes

### Rolling Average

Outputs a rolling mean average CVn OV of the input over the specified Average Period. As new input samples are collected, old samples are discarded. The function will calculate a new average at equally spaced sample intervals.

$$\text{Sample interval} = \frac{\text{averaging period}}{\# \text{ of samples}}$$

$$\text{Rolling Average} = \frac{\text{sum of samples}}{\# \text{ of samples}}$$

Example

# of samples = 10

Average Period = 30 minutes

The first average will appear after 30 minutes, then will be updated every 30/10 or 3 minutes after.

When the Reset Input is ON(1) all accumulated samples are discarded and the output is held until the Reset Input is OFF(0), then the averaging period resets.

Table 4-46 describes the Rolling Average prompts. See Table 4-2 for additional prompts.

**Table 4-46 Rolling Average Prompts**

Prompt	Range/Selections	Definition
RANGE LOW	OFF or number	Enter the output's display limits. Output is not clamped or flashed when it exceeds these limits.
RANGE HIGH		
INPUT	OFF, analog parameter, number	This parameter will be averaged
RESET	OFF, discrete parameter, 0, 1	Resets average
# OF SAMPLES	1-60	Number of samples taken during average period
AVG PERIOD MINS	OFF or number	Number of minutes in average period

**Multiple Input Average (Multiple Avg)**

The output CVn A1 is the instantaneous average of the assigned input points. The average is calculated every scan cycle.

Table 4-47 describes the Multiple Average prompts. See Table 4-2 for additional prompts.

**Table 4-47 Multiple Average Prompts**

Prompt	Range/Selections	Definition
OUT LOW LIMIT	OFF or number	Displayed output value will be clamped and will flash when these limits are exceeded.
OUT HIGH LIMIT		
INPUT #1- INPUT #8	OFF, analog parameter, number	Enter up to 8 inputs to be averaged

### CEMS Block Average

Outputs a block mean average CVn OV over the specified Average Period. The average is calculated from input samples taken at equally spaced Sample Periods. All samples are discarded at the end of the Average Period and the Average Period begins again.

Samples are ignored when Calibrate Hold is ON(1). After the Average Period the new average is calculated using only the samples taken before and after the Hold. If no valid samples are taken, the output maintains its previous value.

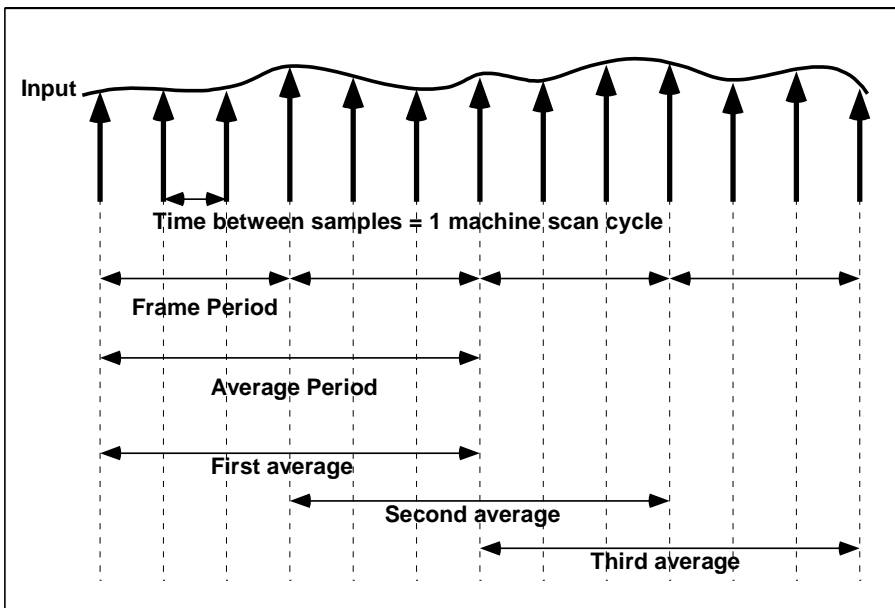
Table 4-48 describes the CEMS Block Average prompts. See Table 4-2 for additional prompts.

**Table 4-48 CEMS Block Average Prompts**

Prompt	Range/Selections	Definition
RANGE LOW	OFF or number	Enter the output's display limits. Output is not clamped or flashed when it exceeds these limits.
RANGE HIGH		
INPUT	OFF, analog parameter, number	Input to be averaged
RESET	OFF, discrete parameter, 0, 1	When discrete is ON(1), average is reset to zero; when ON(1)-to-OFF(0), average restarts.
TIME UNITS	SECONDS, MINUTES, HOURS, or DAYS.	Time units of the averaging period
AVERAGE PERIOD	OFF or number	Number of time units per average period.
SAMPLE PERIOD	OFF or number	Number of time units between samples. Must divide evenly into Average Period.
CALIBRATE HOLD	OFF, discrete parameter, 0, 1	When ON(1), no samples are taken and the output is held.

**CEMS Rolling Average (CEM Rolling Avg)**

Outputs a rolling mean average CVn OV over the specified Average Period. Average is updated every Frame Period thereafter. Samples are taken at every scan cycle of the instrument, except when Calibrate Hold is ON(1).



**Figure 4-17 CEMS Rolling Average**

Table 4-49 describes the CEMS Rolling Average prompts. See Table 4-2 for additional prompts.

**Table 4-49 CEMS Rolling Average Prompts**

Prompt	Range/Selections	Definition
RANGE LOW	OFF or number	Enter the output's display limits. Output is not clamped or flashed when it exceeds these limits.
RANGE HIGH		
INPUT	OFF, analog parameter, number	Input to be averaged
RESET	OFF, discrete parameter, 0, 1	When discrete is ON(1), average is reset to zero; when ON(1)-to-OFF(0), average restarts.
TIME UNITS	Seconds, minutes, hours, or days.	Time units of the averaging period
AVERAGE PERIOD	OFF or number	Number of time units per average period.
FRAME PERIOD	OFF or number	Number of time units per Frame Period. Must divide evenly into Average Period.
CALIBRATE HOLD	OFF, discrete parameter, 0, 1	When ON(1), no samples are taken and the output is held.

## 4.13 Program Alarms

You can program an alarm to be triggered by any extreme input value. To program alarms, select “PROGRAM ALARMS” on the Main Program Menu. Select an alarm to program.

### REFERENCE

When an alarm occurs, it produces an output pulse which can be configured to trigger a discrete output (such as a relay). Refer to Section 4.11 for instructions.

Table 4-50 describes the Alarm prompts. See Table 4-2 for additional prompts.

**Table 4-50 Alarm Prompts**

Prompt	Range/Selections	Definition
ON STATE	See Table 4-3 for choices.	Enter labels for on and off states of alarm
OFF STATE		
ALARM ACTION	HIGH	Alarm when input value $\geq$ setpoint value.
	LOW	Alarm when input value $\leq$ setpoint value.
	DEV	Deviation. Alarm when input value deviates above or below compare point value by an amount $\geq$ setpoint value.
	LDEV	Low Deviation. Alarm when input value deviates below compare point value by an amount $\geq$ setpoint value.
	HDEV	High Deviation. Alarm when input value deviates above compare point value by an amount $\geq$ setpoint value.
	HRATE	High Rate. Alarm when input value increases at rate $\geq$ setpoint value, in units per minute. Negative rate setpoints are processed as positive values. May take up to 30 seconds to activate.
	LRATE	Low Rate. Alarm when input value decreases at rate $\geq$ setpoint value, in units per minute. Negative rate setpoints are processed as positive values. May take up to 30 seconds to activate.
	NONE	No alarm action.
INPUT	OFF, analog parameter, number	Input source monitored by alarm
SETPOINT	OFF, analog parameter, number	Point at which alarm occurs
COMPARE POINT	OFF, analog parameter, number	DEV type only. It is the point against which the input point is compared. The difference between the input point and the compare point is the value which is measured against the alarm set point.



**Table 4-50 Alarm Prompts**

Prompt	Range/Selections	Definition
HYSTERESIS	OFF or number	Hysteresis affects only the point at which an alarm clears. A high alarm will clear when the input is less than the setpoint minus the hysteresis value. A low alarm will clear when the input is greater than the setpoint plus the hysteresis value. A deviation alarm will clear when the input is less than the setpoint minus the hysteresis value.
DELAY TIME	OFF or number	If the alarm condition clears before the delay time (in seconds) expires, no alarm will be indicated.
SAMPLE HOLD	OFF, discrete parameter, 0, 1	When this parameter level = 1(ON), the alarm processing is disabled and the output is held.

## 4.14 Program Totalizers

The optional totalizer integrates an analog value over time. With the input being viewed as a flow rate, the function outputs a running total TLn OV over time.

---

### ATTENTION

Totalizers which exceed the value 999,999 may only be displayed on the dedicated "Totalizer Display". If the value is programmed on other displays or stored to disk, when it exceeds the programmed limits the value may be truncated and the value will flash.

---

Select a Totalizer to program. Table 4-51 describes the Totalizer prompts. See Table 4-2 for additional prompts.

**Table 4-51 Totalizer Prompts**

Prompt	Range/Selections	Definition
INPUT SOURCE	OFF, analog parameter, number.	Input source to be totalized.
OUTPUT LOW LIMIT	OFF or number	The range outside which the displayed output will flash unclamped. Useful for warning operator of unusual condition.
OUTPUT HIGH LIMIT		
ACTION	UP	At each machine scan cycle, an integration of the input is added to the running total. When this total reaches or exceeds the preset value (assumed to be in eng. Units), the discrete output of the totalizer goes high and remains high for 1 scan cycle. The totalizer then resets and starts again. The value resets to either zero or the residual total (final total minus preset) if one exists.
	DOWN	At each machine scan cycle, an integration of the input is subtracted from the preset value. When this result reaches or goes below zero, the discrete output of the totalizer goes high and remains high for 1 scan cycle. The totalizer then resets and starts again. The value resets to either the preset or the residual total (preset plus final total [since final total is either zero or negative]) if one exists.
	DEMAND	On Demand. Same as UP, except executes only while the ON DEMAND INPUT discrete is ON(1). Input is ignored while ON DEMAND INPUT is OFF(0).
	CONTIN	Continuous. Same as UP except the total ignores the PRESET value and integrates "forever" (continuously).
TIME UNITS	SEC, MIN, HOUR, DAY	Time units of the totalizer
ON DEMAND INPUT	OFF, discrete parameter, 0, 1	Appears for Functions as the On Demand input for the DEMAND action. Activates totalizer when ON(1).
PRESET	OFF, analog parameter, number	Up totalizer counts up to this value. Down totalizer counts down from this value.
ZERO CUTOFF	OFF or number	Represents the least value to be accumulated in the totalizer. Input values below this value will be input as zero.
RESETTABLE	YES, NO	If NO, the Totalizer is non-resettable and cannot be reset via the operator keypad. This setting does not affect the action of the reset discrete parameter.
RESET	OFF, discrete parameter, 0, 1.	When the RESET goes high (1) an UP action totalizer will reset to zero, or a DOWN action totalizer will reset to the preset value. Use SY1 F3 to reset with the RESET or F3 key.

## 4.15 Program Profiles

Profile programming is explained in Section 5.

## 4.16 Program Constants

Constants can be programmed here and their values edited Online. Select a constant to program.

Table 4-52 describes the Constant prompts. See Table 4-2 for additional prompts.

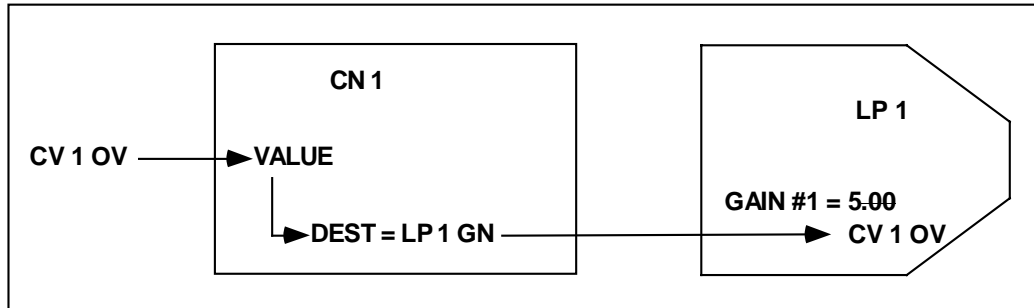
**Table 4-52 Constant Prompts**

Prompt	Range/Selections	Definition
VALUE	OFF, analog parameter, number	If a number, the Constant may be altered Online from the Data Entry menu. If a parameter, this parameter can be directed by DESTINATION to override certain programmed values.
INPUT LOW LIMIT	OFF or number	Display limits (for when viewing Constant on trend display or on bar displays).
INPUT HIGH LIMIT		
DESTINATION		See <b>Destination defined</b> on next page.
	NONE	No destination
	LP <sub>n</sub> GN	LOOP <sub>n</sub> GAIN1
	LP <sub>n</sub> PB	LOOP <sub>n</sub> PROP. BAND #1
	LP <sub>n</sub> RS	LOOP <sub>n</sub> RESET #1
	LP <sub>n</sub> RA	LOOP <sub>n</sub> RATE #1
	LP <sub>n</sub> RB	LOOP <sub>n</sub> RATIO BIAS
	LP <sub>n</sub> IS	LOOP <sub>n</sub> SP INC SLEW LIMIT
	LP <sub>n</sub> DS	LOOP <sub>n</sub> SP DEC SLEW LIMIT
	LP <sub>n</sub> HS	LOOP <sub>n</sub> SP HIGH LIMIT
	LP <sub>n</sub> LS	LOOP <sub>n</sub> SP LOW LIMIT
	AO <sub>n</sub> IS	AO <sub>n</sub> INC SLEW LIMIT
	AO <sub>n</sub> DS	AO <sub>n</sub> DEC SLEW LIMIT
	AO <sub>n</sub> HS	AO <sub>n</sub> IN HIGH LIMIT
	AO <sub>n</sub> LS	AO <sub>n</sub> IN LOW LIMIT
AO <sub>n</sub> IT	AO <sub>n</sub> IMPULSE TIME (type DAT)	
COMM CONSTANT	YES or NO	<p>A constant can receive its value from a remote host. The remote value can then be plotted (via the constant) on a trend for display or to data storage.</p> <p>YES: The constant, when written to remotely via serial communications (with Binary and Modbus Protocols), is written only to the RAM copy of the instrument configuration but not to the nonvolatile flash copy. When the instrument cold starts, the constant reverts back to any value that was manually set with the instrument's displays. That is, after a cold start or power cycle, the constant's value is the last value as set by the instrument and not as set by the remote host.</p> <p>NO: The constant, when written to remotely via serial communications (Binary and Modbus), will be written to the RAM copy of the instrument configuration and also to the nonvolatile flash copy. After a cold start, the constant's value is the last value as set by the Local User Interface or the remote host.</p>

**Destination defined**

To program Loops and Analog Outputs, you select the Program Control Loops or Program Analog Outputs from the Program Mode Menu, then program each menu item. Some of these menu items, such as proportional band or slew limits, are function block parameters; that is, they can be programmed with numerical values only. A Constant's DESTINATION overrides that numerical value with a live value (variable) provided by the Constant's VALUE.

For example, suppose Loop1's Gain #1 is programmed as the number 5.00, and Constant 1's Value is CV 1 OV, the output of Calculated Value #2. By programming Constant1's Destination as LP1GN, Loop1's Gain #1 will no longer be 5.00 but will be continuously updated by the live value provided by CV 1 OV.



**Figure 4-18 Example of Constant Destination**

**IMPORTANT**

Always be certain that the destination is compatible with its associated loop or analog output. A mismatched destination can affect your output and can be difficult to diagnose. Examples: If destination is AO1 IT (impulse time), be sure that AO1 is programmed as a DAT. If destination is LP2 IS, be sure that Loop #2 is a type that has increasing slew limit on its menu.

**ATTENTION**

- If the destination is used, the parameter being overridden by the destination cannot be accessed or changed. For example, Loop Gain cannot be tuned Online in the TUNE LOOP menu.
- If you reprogram destination to another parameter or NONE, the original destination parameter maintains its last live value as determined by the constant's value. If you want the destination's last live value to be zero or NONE:
  - 1 change the constant value to zero or NONE,
  - 2 change to Online mode for 5 seconds to override the previous live value with zero or NONE,
  - 3 change back to program mode,
  - 4 re-program constant's destination to NONE.
- If you program multiple constants with the same destination, only the highest numbered constant's destination takes effect. For example, if Constant #1 and Constant #5 both have destination = AO2 IT, then only Constant #5's value is used by AO2 IT.

## 4.17 Copy Block

Use Copy Block to copy the setup of any function block to another channel of the same function block. For example, if you have programmed AI1 and want AI2 to have the same settings, use Copy Block. If desired, you can make program changes to AI2 after the copy is complete.

If your instrument can run multiple profiles at the same time, Copy Block is useful for copying the parameters of one profile to another. For example, if your instrument can run 2 profiles, it may be useful to have both profiles use the same switches for starting, holding, and resetting. After you program the first profile's parameters, use Copy Block to copy Profile #1 to Profile #2.

### ATTENTION

When copying Analog Output (AO) function blocks the calibration of that channel will also be copied. You will have to recalibrate the destination AO channel(s) after the copy is complete. See section 8.5.

Table 4-53 describes the Copy Block prompts.

**Table 4-53 Copy Block Prompts**

Prompt	Range/Selections	Definition
BLOCK TYPE	AI, AO, AL, CN, CV, DI, DO, LP, TL, SP	Select the function block type to be copied. AI: Analog Input AO: Analog Output AL: Alarm CN: Constant CV: Calculated Value DI: Discrete Input DO: Discrete Output LP: Control Loop SP: Setpoint Profile TL: Totalizer
FROM CHANNEL	NUMBER	Enter the channel number to be copied.
TO CHANNEL	NUMBER, ALL	Enter a channel to copy to. Select ALL to copy from FROM CHANNEL to each channel greater than FROM CHANNEL.
COPY BLOCK		Select this to do the copy. A verification prompt lets you continue or abort the copy.

## 4.18 Program Displays

You can configure up to 10 primary displays using one or more display formats shown in Figure 4-19. The VRX150 also has the displays shown in Figure 4-20 and assign them to appear in specified order when the Display button is pressed. For VRX150 without control, the Auto/Manual key functions as a Display 2 key; that is, it accesses the second of the 10 displays.

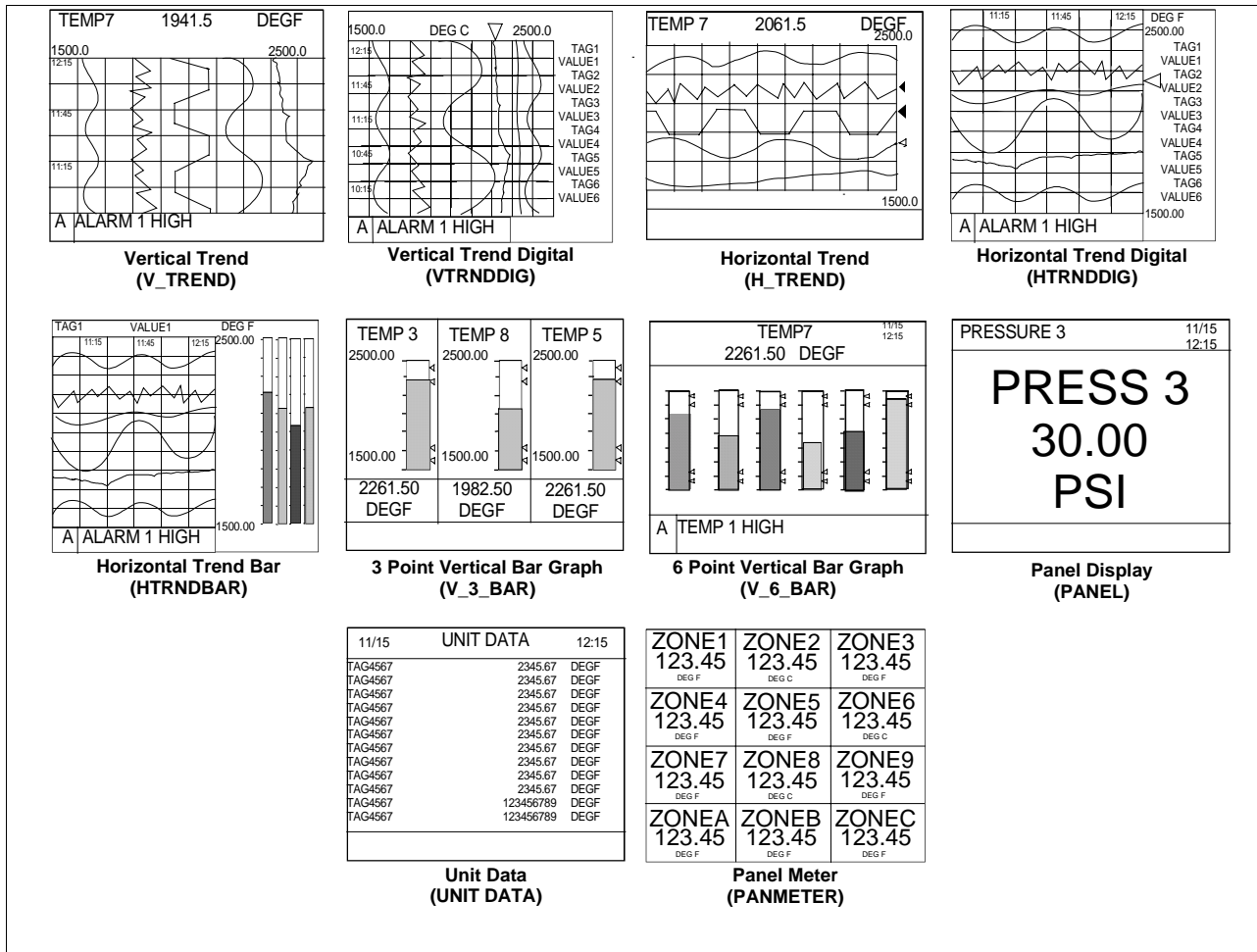


Figure 4-19 Displays Accessible by the Display Buttons

(continued)



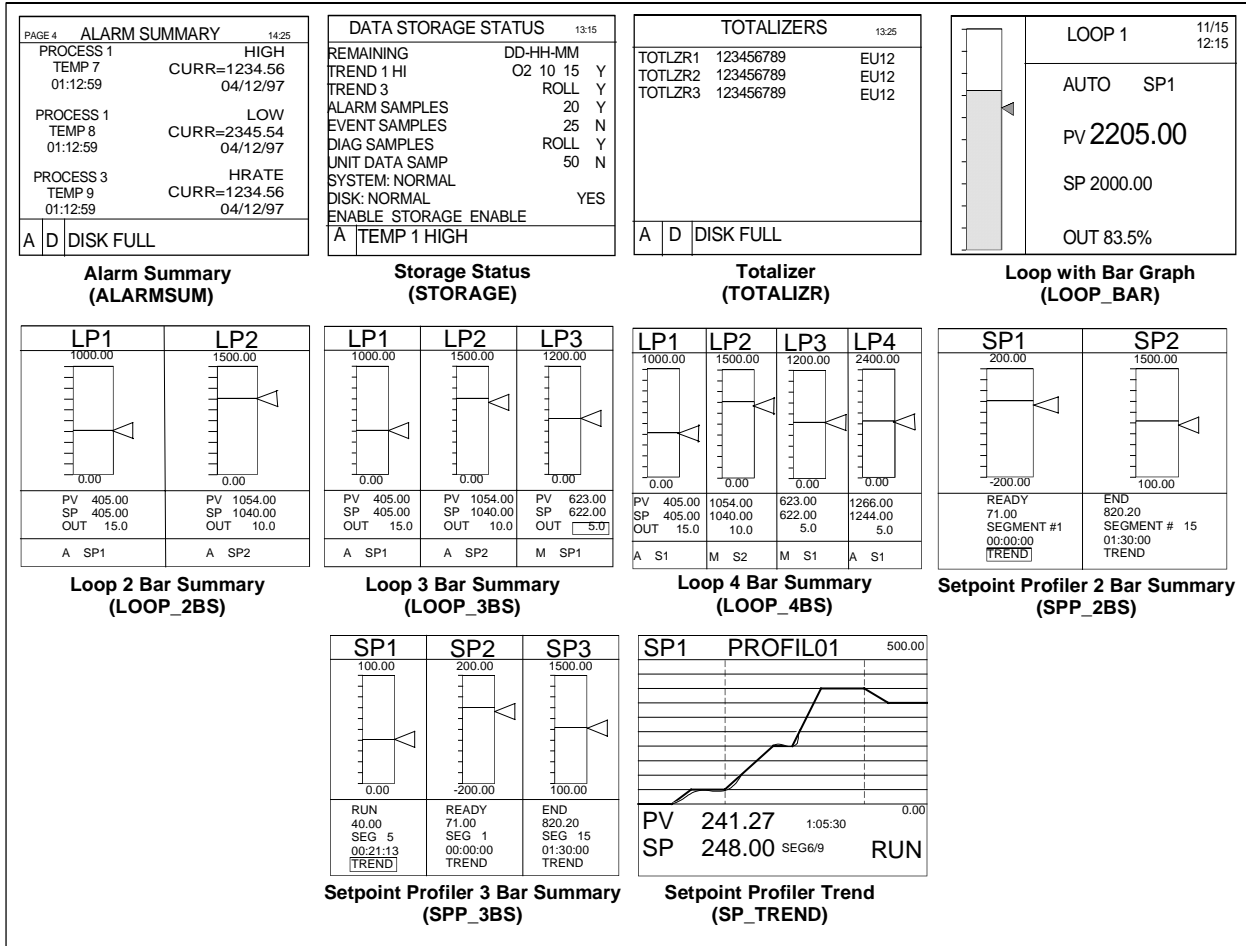


Figure 4-19 Displays Accessible by the Display Buttons (continued)

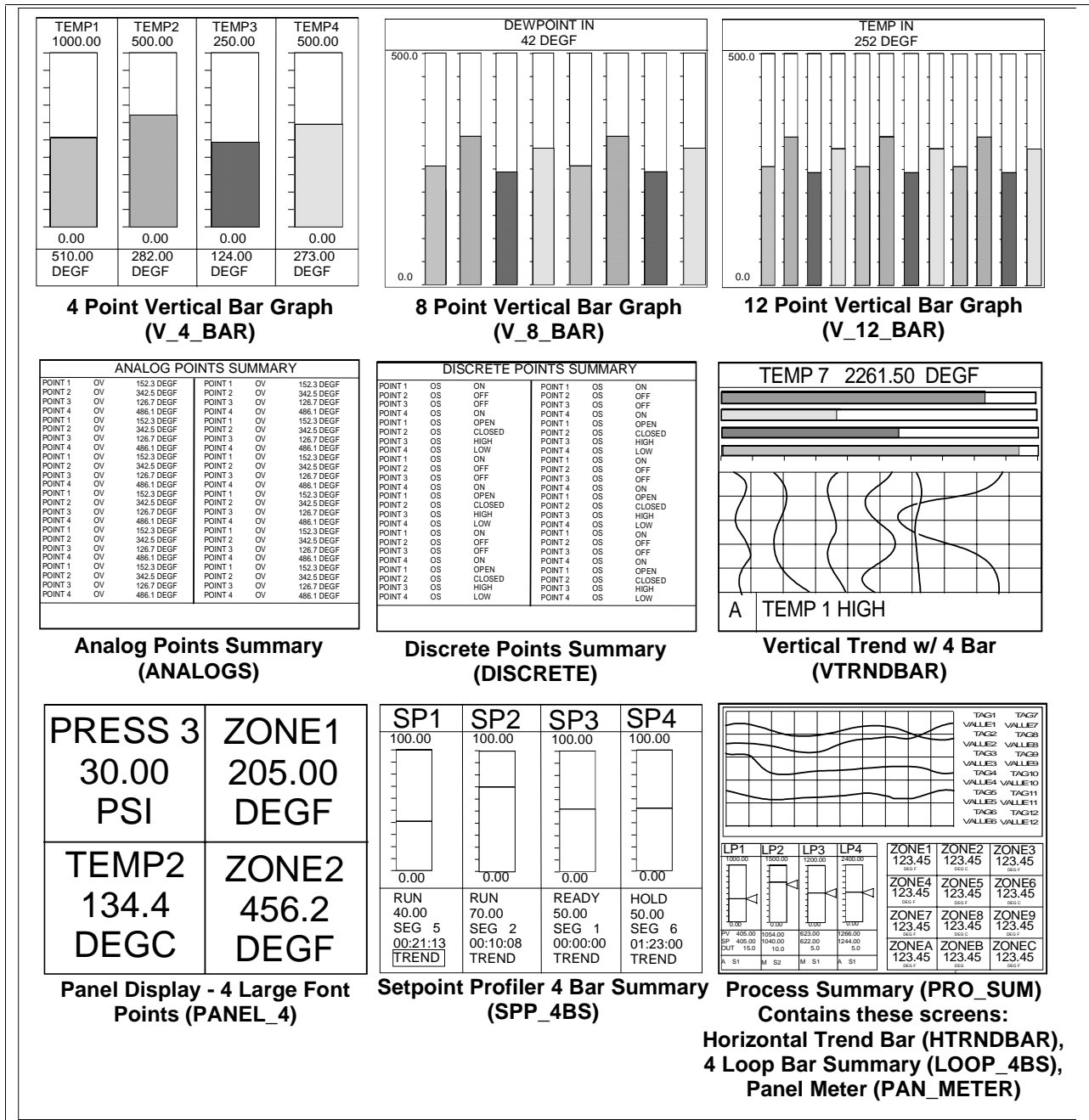


Figure 4-20 VRX150 Displays Accessible By The Display Button

**Display Setup Procedure**

Table 4-54 describes the display setup procedure.

**Table 4-54 Display Setup Procedure**

Step	Action
1	Select Program Displays from the Program mode menu.
2	For each display format desired (trend, bar graph, panel display, unit data), specify points to be displayed.
3	Assign up to 10 displays to the Display button.

**Set Up Trend 1**

Table 4-55 describes the trend display setup procedure.

**Table 4-55 Set Up Trend 1 Prompts**

Prompt	Range/Selections	Definition
ENABLE	YES, NO	Select YES to enable storage of this group of points. Enabled trends are stored in a temporary buffer and can be scrolled back in time.  Select NO to disable storage (and scrolling) of this group of points.
POINT #1 POINT #6 (VPR100/VRX100)  POINT #1 - POINT #12 (VRX150)	Analog or discrete parameters	Select up to 6 (12) analog or discrete points to be displayed as a vertical or horizontal trend. Trends of discrete points will show a value of 1 when ON and 0 when OFF.
NORMAL TIME BASE	5, 15, 30 minutes, or 1, 2, 4, 8, 24 hours, 7, 31 days. Equivalent paper chart speeds are listed in Table 4-56.	Enter the trend display time base for Normal (typically slow speed). The time base is the time period shown for one full screen.
ALT TIME BASE	5, 15, 30 minutes, or 1, 2, 4, 8, 24 hours, 7, 31 days. Equivalent paper chart speeds are listed in Table 4-56.	Enter the trend display time base for Alternate (typically fast speed). The time base is the time period shown for one full screen.

**Table 4-55 Set Up Trend 1 Prompts**

Prompt	Range/Selections	Definition
SET DISPLAY LIMITS	OFF or number	<p>Set the high and low full-scale display limits for each point. If you select OFF for a limit on this display, the limits programmed for the analog point (either RANGE LOW and RANGE HIGH or OUT LOW LIMIT and OUT HIGH LIMIT) will be used as the trend limits for that point.</p> <p>The accuracy of a trended point is determined only by the original output limits of the point, not by setting wider or narrower limits here. Setting excessively narrower limits here will result in a viewable trend with a high degree of inaccuracy when viewed as a % of the screen. To increase accuracy over a narrower range, decrease the programmed output range (limits) of the point itself.</p>
TIMEBASE SELECTOR	OFF, discrete parameter, 0, 1	Enter a discrete parameter which will cause trend to display alternate timebase when ON and normal timebase when OFF.

**Displaying trend points logarithmically**

To display any trend point logarithmically, follow this procedure.

Step	Action
1	Under the Program menu, select the desired point to be displayed logarithmically. For example, for Analog Input #1, select Program Analog Inputs, then select Analog Input #1.
2	Change the point's decimal position to X.XXEXX. Save your changes.
3	Repeat steps 1 and 2 for all points you want to display logarithmically.
4	Under Program Displays, Set Up Trend, specify the trend points you want displayed.
5	Under Set Up Trend, Set Display Limits, change the decimal point position to X.XXEXX. Save your changes. This causes all trend points with the X.XXEXX output decimal position (from steps 1-3) to be displayed logarithmically. Any trend display containing these points will display them logarithmically, with the number of log divisions derived automatically from the low and high limits of the first trend point found with the X.XXEXX decimal position. Trend points without the X.XXEXX decimal position are displayed normally (linearly).

**Table 4-56 Paper Chart Speed Equivalents to Time Base Selections**

Instrument Time/Screen	Paper Chart Vertical Trend cm/hour ( <i>inches/hour</i> )	Paper Chart Horizontal Trend cm/hour ( <i>inches/hour</i> )
	VPR100/VRX100 VRX150	VPR100/VRX100 VRX150
5 minutes	<b>72 (28)</b> <u>154 (60.6)</u>	<b>120 (47.2)</b> <u>246 (96.8)</u>
15 minutes	<b>24 (9.4)</b> <u>51.3 (20.2)</u>	<b>40 (15.7)</b> <u>82 (32.2)</u>
30 minutes	<b>12 (4.7)</b> <u>25.6 (10.1)</u>	<b>20 (7.8)</b> <u>41 (16.2)</u>
1 hour	<b>6 (2.8)</b> <u>12.8 (5.1)</u>	<b>10 (3.9)</b> <u>20.5 (8.1)</u>
2 hours	<b>3 (1.1)</b> <u>6.9 (2.6)</u>	<b>5 (1.9)</b> <u>2.5 (4.1)</u>
4 hours	<b>1.5 (0.6)</b> <u>0.5 (0.2)</u>	<b>2.5 (0.9)</b> <u>0.8 (0.3)</u>

**Table 4-57 VRX 100 Live Trend Buffer Size**

1 Trend Group Enabled									
Points per trend group	# of screen widths	Time base (time width per screen)							
		5 min.	15 min.	30 min.	1 hr.	2 hrs.	4 hrs.	8 hrs.	24 hrs.
<b>1</b>	<b>238</b>	19 hrs	2d 11h	4d 23h	9d 22h	19d 20h	39d 16h	79d 8 h	263 days
<b>2</b>	<b>158</b>	13 hrs	1d 15h	3d 6h	6d 14h	13d 5h	26d 10h	52d 21h	158d 16h
<b>3</b>	<b>119</b>	9 hrs	1d 5h	2d 11h	4d 23h	9d 22h	19d 20h	39d 16h	119 days
<b>4</b>	<b>95</b>	7 hrs	23 hrs	1d 23h	3d 23h	7d 22h	15d 20h	31d 17h	95d 4h
<b>5</b>	<b>79</b>	6 hrs	19 hrs	1d 15h	3d 6h	6d 14h	13d 5h	26d 10h	79d 8h
<b>6</b>	<b>68</b>	5 hrs	17 hrs	1d 10h	2d 20h	5d 16h	11d 8h	22d 16h	68 days
2 Trend Groups Enabled									
Points per trend group	# of screen widths	Time base (time width per screen)							
		5 min.	15 min.	30 min.	1 hr.	2 hrs.	4 hrs.	8 hrs.	24 hrs.
<b>1</b>	<b>119</b>	9 hrs	1d 5h	2d 11h	4d 23h	9d 22 h	19d 20h	39d 16h	119 days
<b>2</b>	<b>79</b>	6 hrs	19 hrs	1d 15h	3d 6h	6d 14h	13d 5h	26d 10h	79d 8h
<b>3</b>	<b>59</b>	5 hrs	14 hrs	1d 5h	2d 11h	4d 23h	9d 22h	19d 20h	59d 12h
<b>4</b>	<b>47</b>	4 hrs	11 hrs	23 hrs	1d 23h	3d 23h	7d 22h	15d 20h	22d 14h
<b>5</b>	<b>39</b>	3 hrs	9 hrs	19 hrs	1d 15h	3d 6h	6d 14h	13d 5h	39d 16h
<b>6</b>	<b>34</b>	2 hrs	8 hrs	17 hrs	1d 10h	2d 20h	5d 16h	11d 8h	34 days

**Table 4-58 VRX 150 Live Trend Buffer Size**

1 Trend Group Enabled									
Points	# of screen widths	Time base (time width per screen)							
		5 min.	15 min.	30 min.	1 hr.	2 hrs.	4 hrs.	8 hrs.	24 hrs.
1	241	20 hrs	2d 12h	5 days	10 days	20d 1h	40d 2h	80d 4h	240d 17h
2	160	13.4 hrs	1d 16h	3d 8h	6d 16h	13d 8h	26d 17h	53d 10h	160d 8h
3	120	10 hrs	1d 6h	2d 12h	5 days	10 days	20d 1h	40d 2h	120d 6h
4	96	8 hrs	24 hrs	2 days	4 days	8 days	16 days	32d 1h	96d 4h
5	80	6.7 hrs	20 hrs	1d 16h	3d 8h	6d 16h	13d 8h	26d 17h	80d 4h
6	69	5.7 hrs	17 hrs	1d 10h	2d 20h	5d 16h	11d 10h	22d 21h	68d 17h
7	60	5 hrs	15 hrs	1d 6h	2d 12h	5 days	10 days	20d 1h	60d 3h
8	53	4.5 hrs	13 hrs	1d 2h	2d 3h	4d 10h	8d 21h	17d 19h	53d 10h
9	48	4 hrs	12 hrs	24 hrs	2 days	4d	8 days	16 days	48d 2h
10	44	3.6 hrs	10 hrs	20 hrs	1d 20h	3d 15h	7d 6h	14d 13h	43d 17h
11	40	3.3 hrs	10 hrs	20 hrs	1d 16h	3d 8h	6d 16h	13d 8h	40d 2h
12	37	3.1 hrs	9 hrs	18 hrs	1d 13h	3d 2h	6d 4h	12d 8h	37 days
2 Trend Groups Enabled									
Points	# of screen widths	Time base (time width per screen)							
		5 min.	15 min.	30 min.	1 hr.	2 hrs.	4 hrs.	8 hrs.	24 hrs.
1	120	10 hrs	1d 6h	2d 12h	5 days	10 days	20d 1h	40d 2h	120d 6h
2	80	6.7 hrs	20 hrs	1d 16h	3d 8h	6d 16h	13d 8h	26d 17h	80d 4h
3	60	5 hrs	15 hrs	1d 6 h	2d 12h	5 days	10 days	20d 1h	60d 3h
4	48	4 hrs	12 hrs	24 hrs	2 days	4 days	8 days	16 days	48d 2h
5	40	3.3 hrs	10 hrs	20 hrs	1d 16h	3d 8h	6d 16h	13d 8h	40d 2h
6	34	2.9 hrs	8.6 hrs	17 hrs	1d 10h	2d 20h	5d 17h	11d 10h	34d 8h
7	30	2.5 hrs	7.5 hrs	15 hrs	1d 6h	2d 12h	5 days	10 days	30d 1h
8	27	2.2 hrs	6.7 hrs	13 hrs	1d 2h	2d 5h	4d 10h	8d 21h	26d 17h
9	24	2 hrs	6 hrs	12 hrs	24 hrs	2 days	4 days	8 days	24d 1h
10	22	1.8 hrs	5.5 hrs	10 hrs	21 hrs	1d 18h	3d 15h	7d 6h	21d 20h
11	20	1.7 hrs	5 hrs	10 hrs	20 hrs	1d 16h	3d 8h	6d 16h	20d 1h
12	19	1.5 hrs	4.6 hrs	9 hrs	18 hrs	1d 13h	3d 2h	6d 4h	18d 12h
3 Trend Groups Enabled									
Points	# of screen widths	Time base (time width per screen)							
		5 min.	15 min.	30 min.	1 hr.	2 hrs.	4 hrs.	8 hrs.	24 hrs.
1	80	6.7 hrs	20 hrs	1d 16h	3d 8h	6d 16h	13d 8h	26d 17h	80d 4h
2	53	4.5 hrs	13.4 hrs	1d 2h	2d 5h	4d 10h	8d 21h	17d 19h	53d 10h
3	40	3.3 hrs	10 hrs	20 hrs	1d 16h	3d 8h	6d 16h	13d 8h	40d 2h
4	32	2.7 hrs	8 hrs	16 hrs	1d 8h	2d 16h	5d 8h	10d 16h	21d 8h
5	27	2.2 hrs	6.7 hrs	13.4 hrs	1d 2h	2d 5h	4d 10h	8d 21h	26d 17h
6	23	1.9 hrs	5.7 hrs	11.5 hrs	22 hrs	1d 21h	3d 19h	7d 15h	22d 21h
7	20	1.7 hrs	5 hrs	10 hrs	20 hrs	1d 16h	3d 8h	6d 16h	20d 1h
8	18	1.5 hrs	4.5 hrs	8.9 hrs	17.8 hrs	1d 11h	2d 23h	5d 22h	17d 19h
9	16	1.3 hrs	4 hrs	8 hrs	16 hrs	1d 8h	2d 16h	5d 8h	10d 16h
10	15	1.2 hrs	3.6 hrs	7.3 hrs	14 hrs	1d 5h	2d 10h	4d 20h	14d 13h
11	13	1.1 hrs	3.3 hrs	6.7 hrs	13 hrs	1d 2h	2d 5h	4d 10h	13d 8h
12	12	1 hr	3 hrs	6 hrs	12 hrs	24 hrs	2d 1h	4d 2h	12d 6h

**Set Up Trend 2**

Set up a second group of up to 6 or 12 points that will be displayed as a horizontal or vertical trend. See Table 4-55 for prompts.

**Set Up Trend 3 (VRX 150 only)**

Set up a third group of up to 6 or 12 points that will be displayed as a horizontal or vertical trend. See Table 4-55 for prompts.

**Set Up Bar Graph 1**

Table 4-59 describes the prompts for setting up Bar Graph 1.

**Table 4-59 Set Up Bar Graph 1 Prompts**

Prompt	Range/Selections	Definition
POINT #1 -POINT #6	OFF, analog parameter, numbers	Select up to 6 analog points, each to be displayed as a vertical or horizontal bar graph. Point #1 - Point #3 are used for 3 point bar graphs.

**Set Up Bar Graph 2**

See Table 4-59 for prompts. For Point #1 - Point #6, enter a second group of up to 6 points that will be displayed as horizontal or vertical bar graphs.

**Set Up Panels**

Table 4-60 describes the prompts for setting up a Panel Display and Panel Meter Display.

**Table 4-60 Set Up Panel Display Prompts**

Prompt	Range/Selections	Definition
POINT #1-POINT #12	Analog or discrete parameters	Select up to 12 analog or discrete points. On the Panel Display, these points will be displayed one at a time at a specified rotation rate and can be seen from 15 feet (4.6 meters); on the VRX150 they are displayed 4 at a time and are visible from the same distance. On a Panel Meter Display, these points will be displayed all at once.

**Set Up Unit Data**

Table 4-61 describes the prompts for setting up a Unit Data Display.

**Table 4-61 Set Up Unit Data Display Prompts**

Prompt	Range/Selections	Definition
POINT #1-POINT #12	Analog or discrete parameters	Select up to 12 analog or discrete points. These points will be displayed as a list.

### Set Up Profile 1

Table 4-62 describes the prompt for setting up a Profile display. Affects the Setpoint Profiler Trend displays only.

**Table 4-62 Set Up Profile Display Prompts**

Prompt	Range/Selections	Definition
DISPLAY TIME	Number	Enter the time width of the profile trend display, in the time units of the profile. The higher this number, the more of a profile will fit on the screen at a time. A value of zero means the entire profile will be displayed, if the profile has no infinite segment loops, no infinite auto cycling, and no external ramp type.

### Set Up Profile 2

### Set Up Profile 3

### Set Up Profile 4

See Table 4-62 for prompt description for setting up displays for Profiles 2-4.



**Assign Displays to Keys**

All instruments have a Display key  and a Display 1 key . The VRX 100 can have an optional Display 2 key . You can assign a total of 10 displays to these keys. Pressing the Display 1 key accesses the format you assign to Display 1 (see table below). The optional Display 2 key accesses Display 2. The Display key accesses Displays 3-10, or if your instrument does not have a Display 2 key, the Display key accesses Displays 2-10.

On the VRX150 with no control option, the Auto/Manual key functions as the Display 2 key.

Table 4-63 describes the prompts for assigning displays to keys.

**Table 4-63 Assign Displays To Keys Prompts**

Prompt	Range/Selections	Definition
BLANKING TIME	OFF, 1 HOUR, 30 MIN, 15 MIN, 5 MIN, 1MIN	This is a screen-saver type function. If enabled, the screen will blank after time selected. Screen will unblank if a key is pressed or an alarm/diagnostic occurs
DISPLAY KEY	0, 1, OFF, PARM	By selecting PARM, you can connect a discrete input parameter which will function as the Display key. Each off-to-on transition of this discrete will behave as if the Display key were pressed. Select 0, 1, or OFF to disable this function.
BACKGROUND COLOR	WHITE, BLACK	This sets the background color of displays to black or white. Affects all Trend (live and replay), Bar Graph, and Panel displays. Does not affect Loop, Unit Data, Summary, or menus.
SELECT PEN COLOR	PEN #1 PEN #2 . . PEN #12	Assign a color to each of up to 12 points. Affects points displayed on all Trend (live and replay), Bar Graph, Loop, and Panel displays. Pen #1 corresponds to Point #1, Pen #2 corresponds to Point #2, etc.  Choices: Green, Cyan, Yellow, Purple, Blue, Brown, Red, Black, White.  Attention: A Yellow pen appears yellow on a black background and orange on a white background.  Caution: Do not select a white pen color for a white background or a black pen color on a black background; these will render your points invisible.

(continued)

**Table 4-63 Assign Displays To Keys Prompts (continued)**

Prompt	Range/Selections	Definition
DISPLAY 1 DISPLAY 2 . . . DISPLAY 10	FORMAT	Select one of the following display formats (Figure 4-19 and Figure 4-20). The corresponding format will be shown when the Display keys are pressed. NONE V_TREND (Vertical Trend) VTRNDDIG (Vertical Trend Digital) VTRNDBAR (Vertical Trend w/ 4 Bars) (VRX 150) H_TREND (Horizontal Trend) HTRNDDIG (Horizontal Trend Digital) HTRNDBAR (Horizontal Trend Bar) V_3_BAR (3 point Vertical Bar Graph) (VPR 100/VRX 100) V_4_BAR (4 point Vertical Bar Graph) (VRX 150) V_6_BAR (6 Point Vertical Bar Graph) V_8_BAR (8 point Vertical Bar Graph) (VRX 150) V_12_BAR (12 point Vertical Bar Graph) (VRX 150) H_4_BAR (4 point Horizontal Bar Graph) (VRX 150) H_6_BAR (6 point Horizontal Bar Graph) (VRX 150) PANEL_4 (4 point Panel Display) (VRX 150) PANEL (Panel Display) (VPR 100/VRX 100) UNIT DATA (Unit Data Display) PANMETER (Panel Meter) ALARMSUM (Alarm Summary) STORAGE (Storage Status) TOTALIZR (Totalizer) LOOP_BAR (Loop with Bar Graph) LOOP_2BS (Loop 2 Bar Summary) LOOP_3BS (Loop 3 Bar Summary) LOOP_4BS (Loop 4 Bar Summary) SPP_2BS (Setpoint Profiles 2 Bar Summary) SPP_3BS (Setpoint Profiles 3 Bar Summary) SPP_4BS (Setpoint Profiles 4 Bar Summary) (VRX 150) SP_TREND (Setpoint Profile Trend) PRO_SUM (Process Summary) (VRX 150) ANALOGS (Analog Summary) (VRX 150) DISCRETE (Discrete Summary) (VRX 150)
	NUMBER	Appears if a trend, bar graph, loop, or setpoint profile trend format is selected. Select which data group to be displayed. Example: if the format is LOOP_BAR, enter 2 to display Loop 2 data. Example: if the format is V_TREND, enter 1 to display Trend 1 data.
	ROTATION RATE	Appears if panel, trend, or bargraph display format is selected. Select number of seconds each point will be shown on the panel display or at the top of the trend or bargraph displays: 1, 2, 3, 4, 5, 10, 15, 20, 30, 40, 50, 60

## 4.19 Enable Features

Features can be restored to or removed from menus and displays simply by turning them On (ENABLE) or Off (DISABLE) here. Disabled functions and their data are not destroyed or erased—they just cannot be viewed on the display. For example, a programmed constant retains its value and continues to function in calculations whether it is disabled or enabled.

**Table 4-64 Enable Features Prompts**

Prompt	Range/Selections	Definition
EXPANDED INPUT	ENABLE, DISABLE	DISABLE removes the LAG and SAMPLE/HOLD functions from the Analog Input Programming menu.
PYROMETRY	ENABLE, DISABLE	DISABLE removes all the Rayotube and Spectray ranges from the list of types on the Program Analog Input menu.
AI VALUE ADJUST	ENABLE, DISABLE	DISABLE removes the ANALOG INPUT ADJUST from the Online Data Entry menu, which disables the ability to apply adjust or emissivity corrections.
DI/DO FORCING	ENABLE, DISABLE	DISABLE removes the FORCE DI/DO POINTS from the Online Data Entry menu, which removes the ability to force any DI/DO on or off.
ALARMS	ENABLE, DISABLE	DISABLE removes access to the entire alarm system. Any alarms already programmed will still operate, giving message stripes and operating relays. There will be no alarm summary or related displays.
CONSTANTS	ENABLE, DISABLE	DISABLE removes the Constant entry display, thus removing the ability to set or adjust CN values. CNs previously programmed will continue to exist.
LABELING	ENABLE, DISABLE	DISABLE removes the labeling prompts from the individual parameter programming submenus. Labeling can still be entered from the "ENTER LABELS" item on the main Program menu.
REVIEW PROGRAM	ENABLE, DISABLE	DISABLE removes the REVIEW PROGRAMMING function from the main Online menu.
DISK REPLAY	ENABLE, DISABLE	DISABLE removes the menu items which allow access to the Online retrieval of stored data.
ZOOM	ENABLE, DISABLE	DISABLE removes the menu items which allow access to the Online trend Zoom feature.
POINT DETAIL	ENABLE, DISABLE	DISABLE removes the menu items which allow access to the Online trend Point Detail feature.
TIMEBASE SELECT	ENABLE, DISABLE	DISABLE removes the menu items which allow access to the manual Trend Timebase Select capability.
CUSTOM INPUT	ENABLE, DISABLE	DISABLE removes INPUT ALGORITHM prompt from the Program Analog Input menu.

## 4.20 Program Security

Security lets you protect certain menu items and functions from unwanted or accidental access. Access to a secured item requires entry of a 3-digit master or operator code.

Select “PROGRAM SECURITY” to display the Security menu (if security is active, you will be prompted to enter the master code before continuing).

### REFERENCE

If the master or operator’s security code is lost or forgotten, a security bypass procedure is available. See Appendix A.

Table 4-65 describes the Security prompts.

**Table 4-65 Security Prompts**

Prompt	Range/Selections	Definition
ENABLE SECURITY	YES, NO	Set to Yes to activate security on all enabled security items having a non-zero master or operator’s code. <i>If set to No, no items will be secure!</i>
MASTER SEC CODE	3 digit number	Set to a non-zero value; a value of zero offers no security. Secures the following items:  MEMORY CLEAR SERVICES in Maintenance mode.  PROGRAM SECURITY in Program mode  Changing out of Online Mode. (See SET MODE.)
	SET MODE	Set to Yes to secure changing from Online mode to Program or Maintenance modes.
OPERATOR SEC CODE	3 digit number	Enter a non-zero operator security code value; a value of zero offers no security. Secures the following items (if set to Yes).
	AUTO/MANUAL	Set to Yes to secure Online changes between a loop’s Auto and Manual modes.
	SP1/SP2	Set to Yes to secure Online changes between a loop’s SP1 and SP2.
	SETUP PARAMETERS	Set to Yes to secure changes to: <ul style="list-style-type: none"> <li>• Online Data Entry menu items: <ul style="list-style-type: none"> <li>Alarm Setpoints</li> <li>Analog Input Adjust</li> </ul> </li> <li>• Online Tune Loop menu</li> </ul>
	REVIEW PROGRAM	Set to Yes to secure Online access to Review Programming (via REVIEW PROGRAMMING menu).
	DATA STORAGE	Set to Yes to secure access to any part of data storage (via Online DATA STORAGE menu). Does not affect access to Online DATA STORAGE STATUS display.
	PROFILER	Set to Yes to secure access to all Setpoint Profiler menus and displays.

## 4.21 Serial Communications

Serial Communications is an optional feature that lets the instrument exchange data with a host device (a PC running Honeywell or other compatible software) on an RS422/485 data link. Using Honeywell protocols, Binary or Modbus RTU, this link can be used to transfer configurations and data. Set up the link as follows.

Table 4-66 describes the Serial Communications prompts.

**Table 4-66 Serial Communications Prompts**

Prompt	Range/Selections	Definition																				
UNIT ADDRESS	1-254	Enter the unit's address. Use a number once only so that each address on the link is unique.																				
PROTOCOL	Binary, Modbus RTU	Select the correct protocol.																				
BAUD RATE	1200, 2400, 4800, 9600, 19200, 38400, 76800.	Enter the speed of data transfer. All equipment on the link must be set to match the host setting.																				
PARITY	EVEN, ODD, NONE	Appears for binary protocol only. All equipment on the link must be set to match the host setting.																				
BYTE ORDER		<p>Appears for Modbus protocol only.</p> <p><u>Example</u>                      Decimal number 25.38                        Floating point number                          Register 1   Register 2  </p> <table border="1"> <thead> <tr> <th>Choice</th> <th>Meaning</th> <th>Byte Order</th> <th>Result for 25.38</th> </tr> </thead> <tbody> <tr> <td>FP B</td> <td>Big Endian</td> <td>0123</td> <td>41 CB 0A 3D</td> </tr> <tr> <td>FP BB</td> <td>Big Endian Byte Swap</td> <td>1032</td> <td>CB 41 3D 0A</td> </tr> <tr> <td>FP L</td> <td>Little endian</td> <td>3210</td> <td>3D 0A CB 41</td> </tr> <tr> <td>FP LB</td> <td>Little endian Byte swap</td> <td>2301</td> <td>0A 3D 41 CB</td> </tr> </tbody> </table>	Choice	Meaning	Byte Order	Result for 25.38	FP B	Big Endian	0123	41 CB 0A 3D	FP BB	Big Endian Byte Swap	1032	CB 41 3D 0A	FP L	Little endian	3210	3D 0A CB 41	FP LB	Little endian Byte swap	2301	0A 3D 41 CB
Choice	Meaning	Byte Order	Result for 25.38																			
FP B	Big Endian	0123	41 CB 0A 3D																			
FP BB	Big Endian Byte Swap	1032	CB 41 3D 0A																			
FP L	Little endian	3210	3D 0A CB 41																			
FP LB	Little endian Byte swap	2301	0A 3D 41 CB																			
DOWNLOAD LOCKOUT	YES, NO	Set to YES to prevent configurations from being downloaded from a PC with SCF software.																				

## 4.22 Set Clock

To assure data, alarms, and events are properly time stamped, the clock must be properly set. The clock uses military time.

Select "SET CLOCK" from the main Program menu. Enter the date and time with the following prompts.

Table 4-67 describes the Set Clock prompts.

**Table 4-67 Set Clock Prompts**

Prompt	Range/Selections	Definition
MONTH	JAN - DEC	Enter the date and time
DAY	1-31	
YEAR	Enter year	
HOURS	0-23	
MINUTE	0-59	
FORMAT	USA = MMDDYY INTL = DDMMYY	Select clock format

### IMPORTANT

Resetting the clock can affect the storage schedule of a unit in service.

If the clock is set back more than 5 minutes, the following actions will take place:

Data in storage buffers will be copied to the floppy disk and the buffers will then be cleared.

Data collection for storage will stop until the operator reinitializes the schedule.

If the clock is set back less than 5 minutes, collection of data storage and trends will stop until the setback time elapses and the clock "catches up" with the original collection schedule. A warning prompt will appear on the display before these actions occur. You can then cancel the clock change if desired.

## 4.23 Load/Store Config

Instrument configurations and calibrations can be stored to and loaded from floppy disk. The front bezel must be closed. Configurations have filename extension .LNC. Calibrations have filename extension .LNL.

### ATTENTION

File types on a disk cannot be mixed. The disk must contain only setpoint programs, configuration and calibration files, not data storage files.

Table 4-68 describes the Access Config Files prompts.

**Table 4-68 Access Config Files Prompts**

Prompt	Range/Selections	Definition
STORE CONFIG TO DISK	FILE01 CYCLE01 DRYER01 PROD01 RECORD01 TANK01 UNIT01 LOOP01 REACTR01 CONFIG01 KILN01 VESSEL01 CALIB01 WCHEM01 PRESS01 FURNCE01 DEMIN01 CONTRL01 BATCH01 FERMTR01 LEHR01 LINE01 STRLZR01 OVEN01 ZONE01	Specify a filename and number (01-99) for the configuration. Press Enter to store the configuration.
STORE CALIB TO DISK	Same choices as STORE CONFIG TO DISK	Specify a filename and number (01-99) for the calibration. Press Enter to store the calibration.
LOAD CONFIG FROM DISK	Select a configuration filename.	First you must clear the instrument's configuration memory. Press Enter to clear, or Menu to abort and exit the menu. Once the memory is clear, select a filename from the floppy disk. Press Enter to load the configuration into the instrument.
LOAD CALIB FROM DISK	Select a calibration file.	Select a calibration file and press Enter to load.

### ATTENTION

Only function blocks that have been programmed are loaded to the instrument. Function blocks in the receiving instrument are not replaced unless the incoming function blocks are programmed differently. For example, if the instrument has AI1 and AI2 programmed, and the configuration being loaded from the floppy contains AI3 only, then AI1 and AI2 are undisturbed on the instrument and AI3 is added. If the configuration being loaded contains a different AI2 and a new AI3, then AI1 is undisturbed, AI2 is replaced by the different AI2, and AI3 is added.

## 4.24 Scan Rate

Scan rate is the time required to measure inputs, execute function blocks (AI, Loops, AO, DI, DO, CV, etc.) and update outputs. It is also known as the machine cycle, scan cycle, and update rate.

The Scan Rate prompt lets you set the scan rate of the instrument to a value slower than the maximum rate allowed by the hardware. The hardware will determine the default scan rate. Allowable entries are 250 milliseconds, 500 milliseconds, or 1 second. 250 ms rate is only available on 2 input units.

We recommend the following scan rates for the following configurations.

**Table 4-69 Suggested Scan Rates**

250 ms	500 ms	1 second
≤ 2 inputs	≤ 8 inputs	≥ 12 inputs
2 control loop	≤ 4 control loops	≥ 4 control loops
2 profiler	≤ 4 profilers	≥ 4 profilers
≤ 12 CVs	≤ 24 CVs	≥ 32 CVs

### NOTE

These are suggested scan rates. In general, if your instrument responds too slowly, use a slower (higher) scan rate. You can use a faster (lower) scan rate than suggested here, but be aware of possible sluggish display and button response time.

---



## 4.25 Select Language

SELECT LANGUAGE on the Main Program Menu changes the instrument's language to:

- English
- Spanish
- German
- French
- Italian

## 4.26 Data Storage

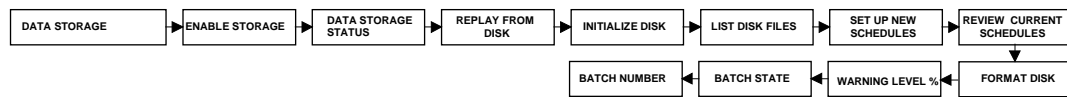
### Overview

Data Storage lets you store trends, unit data, alarms, events, and diagnostics in separate files on a floppy disk for later analysis and review (replay). Data can be reviewed onscreen or on a PC with SDA data analysis software. Setpoint Programs, instrument configurations and calibrations are not part of the Data Storage feature.

Setup and configuration of Data Storage is described in this section; Online operation is described in Section 7.4.

### Data Storage menu

The Data Storage menu items appear in the following order.



### Setup procedure

Data Storage setup is performed Online to avoid interruption of current storage. The steps are described briefly Table 4-70.

**Table 4-70 Data Storage Setup Procedure**

Step	Action
1	Access DATA STORAGE Online. Insert a formatted 1.44MB or 120MB disk into the disk drive. If necessary, format disk using FORMAT DISK (see page 179). See Opening/Closing the Front Bezel in Section 3.6. Only 1.44MB floppy disks can be formatted on the instrument; 120MB disks must be formatted on a PC.
2	Select ENABLE STORAGE. See Enable Storage below.
3	Select SET UP NEW SCHEDULES to specify storage data, mode, and other settings. See page 171.
4	Select STORAGE ALLOCATION to specify storage rates. See page 177.
5	Select WARNING LEVEL % to specify the capacity warning level. See page 179.
6	If using a 120MB/Zip disk, preinitialize the disk using DSU software. This will reduce initialization time (step 7) dramatically from hours to minutes.
7	Select INITIALIZE DISK, then select USE NEW SCHEDULES to initialize the disk with the settings you created in steps 3 and 4. See page 181.

### Enable storage

Set to Enable to turn on storage. **If Disabled, no storage will occur, regardless of any other settings.**

## Set Up New Schedules

This item contains setup menus for all data sets. Select it to specify what data to store and how to store it. If a type of data storage is not scheduled, no disk file will be created for it.

---

### ATTENTION

If you make **any** changes to any item under SET UP NEW SCHEDULES, you must initialize using new schedules to activate those changes.

---

The following items appear under SET UP NEW SCHEDULES and are described under the following headings.

- ***Trend Data 1***
- ***Trend Data 2***
- ***Trend Data 3***
- ***Alarms***
- ***Events***
- ***Diagnostics***
- ***Unit Data***
- ***Storage Allocation***
- ***Batch Control***

### ***Trend Data 1***

At the top of the display the message “SETUP IS CURRENT” indicates that current setup for storage of TREND 1 is exactly as shown. If the message is “SETUP IS NOT CURRENT”, then the TREND 1 setup has been changed since a disk was last initialized. To make a NOT CURRENT setup CURRENT, you must initialize the disk using new schedules.

Set up Trend Data 1 as described in Table 4-71.

**Table 4-71 Prompts For Storage Setup Of Trends, Alarms, Events, Diagnostics**

Prompt	Range/Selections	Definition
STORAGE MODE	CONTIN, BATCH, or NONE	Continuous storage becomes active immediately upon initialization. Batch storage is controlled by a discrete parameter (see BATCH CONTROL) or by start/stop batch menu item. Batch data may be started and stopped several times in a single file until the file is full. Batch start increments a batch number that is stored along with the data. The batch number may be used for data retrieval and analysis using SDA data analysis software.
COPY DISPLAY SETUP		Select this to copy the following Trend 1 or 2 Display data to Trend 1 or 2 Storage data: Point #1–#6, set display limits, timebase (high rate) selector. Once setup is copied, it can be altered.
POINT #1 - POINT #6 (VPR100 & VRX100)  POINT #1 - POINT #12 (VRX150)	Analog or discrete parameter	Select the data points for the trend.
LOW RATE	Seconds: .5, 1, 2, 3, 4, 5, 6, 7, 8, 9, 10, 20, 30, 40, 50  Minutes: 1, 2, 3, 4, 5, 10, 15, 20, 30, 40, 50  Hours: 1	Enter data collection rate. This is how often the data points are sampled. The .5 sec rate cannot exceed 6 points total in Trends 1-3.
HIGH RATE	Seconds: .5, 1, 2, 3, 4, 5, 6, 7, 8, 9, 10, 20, 30, 40, 50  Minutes: 1, 2, 3, 4, 5, 10, 15, 20, 30, 40, 50  Hours: 1	Enter data collection rate. This is how often the data points are sampled. The .5 sec rate cannot exceed 6 points total in Trends 1-3.
ROLLOVER	ON, OFF	Select ON to continue gathering and storing data after the file becomes full. The new data will replace the oldest data on the disk as it is collected. No warning will be given.  Select OFF to stop storage of this data type when the disk space for it becomes full. A "DISK FULL" message will then appear. Data is buffered until a new disk is inserted and initialized.
SET DISPLAY LIMITS	OFF or number	Enter upper and lower limit values for the trend display for each point. If NONE then the trend will use the programmed limits for each point.

**Table 4-71 Prompts For Storage Setup Of Trends, Alarms, Events, Diagnostics (continued)**

Prompt	Range/Selections	Definition
HIGH RATE SELECTORS	SELECTOR	This discrete triggers the high storage rate when ON(1) and the low storage rate when OFF.
	CHANGE WITH KEY	This option enables/disables storage rate changes from the Trend display Point/Trend menu. If YES, storage Trend's high rate will be used when display Trend's alternate timebase is selected from the Online Point/Trend menu; Storage Trend's low rate will be used when display Trend's normal timebase is selected. See Table 6-2, Point/Detail Menu Prompts, Timebase.
EXTERNAL ENABLE	OFF, discrete parameter, 0, 1	When ON(1), this discrete parameter will allow storage of the data type; when off storage for the data type will stop. This enable is independent of the storage mode; it does not control batch start/stop.
SELECT FILENAME	FILE      CYCLE      DRYER PROD      RECORD      TANK UNIT      LOOP      REACTR CONFIG      KILN      VESSEL CALIB      WCHEM      PRESS FURNCE      DEMIN      CONTRL BATCH      FERMTTR      LEHR LINE      STRLZR      OVEN ZONE	Select a file name to identify the type of data to be stored.

**Trend Data 2 & 3**

Trend Data 2 and Trend Data 3 use the same prompts as in Table 4-71. TREND DATA 3 does not have COPY DISPLAY SETUP or CHANGE WITH KEY prompts because there is no corresponding Display Trend 3 to be copied.

**ATTENTION**

A maximum of 12 data points per second can be stored in Trends 1, 2, 3, and Unit Data combined.

**Alarms**

Alarm data storage consists of a complete log of alarms, including time of occurrence, time of clearing, value of the alarm parameter, the alarm sense (high, low, etc.) and the batch identification number, if present. The alarm prompts are: STORAGE MODE, ROLLOVER, EXTERNAL ENABLE, SELECT FILENAME, ALARM SAMPLES. See Table 4-71 and Table 4-74 for descriptions.

Depending on your selections, data collection will begin when the first alarm occurs, or when the first alarm occurs after a batch start.

**Events**

Event storage consists of a complete log of events including the event title, time of occurrence, the status or value after the change, and the batch identification number, if present. When event storage is running, loop and instrument mode events are always stored; discrete input and output events are stored only if first enabled under those items' program menus (see Sections 4.10 and 4.11).

**Table 4-72 Stored Events**

Event title	Event status/value
Setpoint choice	SP1, SP2
Control action	Forward, Reverse
Tuning Set	Set 1, Set 2
Instrument Mode	Online, Program, Maint
Control Mode	Auto, Manual, RMan
Setpoint 1	SP1's value
Setpoint 2	SP2's value
Control Output	Loop's output value
Discrete Input	On, Off
Discrete Output	On, Off

Event storage setup is done with the following parameters: STORAGE MODE, ROLLOVER, EXTERNAL ENABLE, SELECT FILENAME, EVENT SAMPLES. See Table 4-71 and Table 4-74 for parameter descriptions.

Depending on your selections, data collection will begin when the first event occurs, or when the first event occurs after a batch start.

Barcode data is also stored in the event file.

**Diagnostics**

Data storage for Diagnostics is a complete log of all diagnostic messages. It includes the diagnostic code or identifier message and its time and date of occurrence.

Setup is done with the following parameters: STORAGE MODE, ROLLOVER, EXTERNAL ENABLE, SELECT FILENAME, DIAG SAMPLES. See Table 4-71 and Table 4-74 for descriptions.

Depending on your selections, data collection will begin when the first diagnostic occurs, or when the first diagnostic occurs after a batch start occurs.

When calibration is executed, the record is time stamped and stored to the diagnostic file.

**Unit Data**

Values for up to 12 points (analog input, calculated value, discrete input, discrete output, totalizer, etc.) can be sampled at user-definable intervals and stored on disk. The sample interval must be set by a schedule or triggered by a discrete event. Prompts are described in Table 4-73.

**Table 4-73 Unit Data Prompts**

Prompt	Range/Selections	Definition
STORAGE MODE	OFF, CONTIN, BATCH, or ON COMMAND	Continuous storage becomes active immediately upon initialization. Batch storage is controlled by a discrete parameter (see BATCH CONTROL, page 179) or by start/stop batch menu item. Batch data may be started and stopped several times in a single file until the file is full. Batch start increments a batch number that is stored along with the data. The batch number may be used for data retrieval and analysis using SDA data analysis software. ON COMMAND storage collects a single sample of data whenever the EXTERNAL ENABLE discrete makes an off-to-on transition. If this mode is used, then SET UP SCHEDULE is ignored.
COPY DISPLAY SETUP		Copies the data point list already set up for a currently active Unit Data display.
ASSIGN POINTS	OFF or analog parameter or discrete parameter	Enter up to 12 points.
ROLLOVER	ON, OFF	Select ON to continue gathering and storing trend data after the Unit data file becomes full. The new data will replace the oldest data on the disk as it is collected. No warning will be given.  Select OFF to stop trend storage when trend space becomes full. A "DISK FULL" message will then appear. Data is buffered until a new disk is inserted and initialized.
EXTERNAL ENABLE	OFF, discrete parameter, 0, 1	This discrete parameter will allow Unit data storage when ON(1) and will stop Unit data storage when OFF(0). This enable is independent of the storage mode; it does not control batch start/stop.

**Table 4-73 Unit Data Prompts (continued)**

Prompt	Range/Selections	Definition
SET UP SCHEDULE	START HOUR START MINUTE START MONTH START DAY START YEAR INTERVAL DAYS INTERVAL HOURS INTERVAL MINS	If no external enable is specified, select a starting date and time and an interval for periodic storage. Set Interval Days to 31 if you want the timed schedule to repeat on the same day each month.  This timer schedule will run in any Data Storage mode. In CONTINUOUS mode, it will start as scheduled and collect samples until stopped by manual command (the ENABLE STORAGE in the Online Data Storage menu).  In BATCH mode, the timer schedule will be started and stopped by an Online menu selection (BATCH STATE) by the operator, or by an optional discrete input designated as the BATCH CONTROL.
SELECT FILENAME	FILE CYCLE DRYER PROD RECORD TANK UNIT LOOP REACTR CONFIG KILN VESSEL CALIB WCHEM PRESS FURNCE DEMIN CONTRL BATCH FERMTTR LEHR LINE STRLZR OVEN ZONE	Select a file name to identify the type of Unit data to be stored.

**ATTENTION**

A maximum of 12 data points per second can be stored in Trends 1, 2, 3, and Unit Data combined.



**Storage Allocation**

Choose STORAGE ALLOCATION under SET UP NEW SCHEDULES menu to see the disk capacity and to allocate storage of each data type. See Table 4-74.

**Table 4-74 Storage Allocation Prompts**

Prompt	Range/Selections	Definition
DISK CAPACITY		Displays total time available for non-rollover trend storage based on the low storage rates programmed. See Table 4-75 and Table 4-76. . The disk capacity will display zeros if the storage mode is set to OFF for all 3 trends.
TREND#1 LO RATE	Seconds: .25, .5, 1, 2, 3, 4, 5, 6, 7, 8, 9, 10, 20, 30, 40, 50 Minutes: 1, 2, 3, 4, 5, 10, 20, 30, 40, 50 Hours: 1	This rate can be altered here or in the trend data setup (see Table 4-71). If the low storage rates are changed, the disk capacity will reflect the new trend capacity. Enter data collection rate. This is how often the data points are sampled. The .25 ms selection is only available for 2-input instruments with no more than 3 points total in Trends 1-3. The .5 sec rate cannot exceed 6 points total in Trends 1-3.
TREND#1 HI RATE	Seconds: .25, .5, 1, 2, 3, 4, 5, 6, 7, 8, 9, 10, 20, 30, 40, 50 Minutes: 1, 2, 3, 4, 5, 10, 20, 30, 40, 50 Hours: 1	This rate can be altered here or in the trend data setup (see Table 4-71). If the hi storage rates are changed, the disk capacity will reflect the new trend capacity. Enter data collection rate. This is how often the data points are sampled. The .25 ms selection is only available for 2-input instruments with no more than 3 points total in Trends 1-3. The .5 sec rate cannot exceed 6 points total in Trends 1-3.
TREND#2 LO RATE	See TREND#1 LO RATE	
TREND#2 HI RATE	See TREND#1 HI RATE	
TREND#3 LO RATE	See TREND#1 LO RATE	
TREND#3 HI RATE	See TREND#1 HI RATE	
UNIT DATA SAMPLES	0-10000	Select maximum number of samples of unit data to be stored. Default capacity is 1000. Shown only if unit data was set up as part of the schedule.
ALARM SAMPLES	0-1600	Select maximum number of samples of alarm transitions (off-to-on and on-to-off) to be stored. Default capacity is 100. Shown only if alarms were set up as part of the schedule.
EVENT SAMPLES	0-1600	Select maximum number of samples of events to be stored. Default capacity is 100. Shown only if events were set up as part of the schedule.
DIAG SAMPLES	0-1600	Select maximum number of samples of diagnostics to be stored. Default capacity is 100. Shown only if diagnostics were set up as part of the schedule.

**ATTENTION**

Alarm, Events, Diagnostics and Unit Data storage mode is defaulted to OFF. Each storage mode must be enabled for storage.

**Table 4-75 Capacity of 1.44 Megabyte Floppy Disk**

Disk Storage Capacity										
Number of Trend Files on Disk	Total Number Of Points	Rate Of Storage To All Trend Files Estimated Disk Capacity								
		1 sec.	5 sec.	10 sec.	30 sec.	1 min.	5 min.	10 min.	30 min.	1 hour
1	2	19.6 hrs.	4 days	8.1 days	24.5 days	1.6 mos.	8.1 mos.	1.3 yrs.	4.0 yrs.	8.0 yrs.
	4	11.7 hrs.	2.4 days	4.9 days	14.7 days	29.4 days	4.9 mos.	9.8 mos.	2.4 yrs.	4.8 yrs.
	6	8.6 hrs.	1.8 days	3.6 days	10.8 days	21.6 days	3.6 mos.	7.2 mos.	1.7 yrs.	3.5 yrs.
2	2	14.1 hrs.	2.9 days	5.8 days	17.6 days	35.3 days	5.8 mos.	11.7 mos.	2.9 yrs.	5.8 yrs.
	6	7.3 hrs.	1.5 days	3.0 days	9.2 days	18.4 days	3.0 mos.	6.1 mos.	1.5 yrs.	3.0 yrs.
	10	5.1 hrs.	1.0 day	2.1 days	6.3 days	12.7 days	2.1 mos.	4.2 mos.	1.0 year	2.1 yrs.
3	6	6.5 hrs.	1.3 days	2.7 days	8.1 days	16.3 days	2.7 mos.	5.4 mos.	1.3 yrs.	2.6 yrs.
	9	4.9 hrs.	1.0 day	2.0 days	6.2 days	12.4 days	2.0 mos.	4.1 mos.	1.0 year	2.0 yrs.
	12	3.9 hrs.	19.6 hrs.	1.6 days	4.9 days	9.8 days	1.6 mos.	3.2 mos.	9.8 mos.	1.6 yrs.
	18	2.8 hrs.	14.4 hrs.	1.2 days	3.6 days	7.2 days	1.2 mos.	2.4 mos.	7.2 mos.	1.1 yrs.

For combinations not shown above, use the formula on the left for an estimate of storage disk capacity. Use the formula on the right to estimate the amount of time trend data will be stored to the buffer (while the floppy disk is removed).

$$\text{Estimated Trend Disk Capacity (Hours)} = \frac{396 R_1}{F_1 + \left( F_2 \frac{R_1}{R_2} + F_3 \frac{R_1}{R_3} \right)}$$

$$\text{Estimated Trend Buffer Capacity (Hours)} = \frac{26 R_1}{F_1 + \left( F_2 \frac{R_1}{R_2} + F_3 \frac{R_1}{R_3} \right)}$$

R<sub>1</sub> = Storage Rate for Trend 1 in seconds.      F<sub>1</sub> = Capacity Factor for Trend 1, based on number of points  
 R<sub>2</sub> = Storage Rate for Trend 2 in seconds.      F<sub>2</sub> = Capacity Factor for Trend 2, based on number of points  
 R<sub>3</sub> = Storage Rate for Trend 3 in seconds.      F<sub>3</sub> = Capacity Factor for Trend 3, based on number of points

Capacity Factors	
Number Of Points	Factor F <sub>1</sub> , F <sub>2</sub> , or F <sub>3</sub>
0	0.00
1	14.00
2	20.16
3	26.52
4	33.60
5	38.76
6	45.81
7	50.4
8	56.0
9	63.0
10	72.0
11	84.0
12	84.0

**Table 4-76 Capacity of 120 Megabyte Disk**

<i>Points per trend file</i>	<i>Rate Of Storage To All Trend Files</i>							
	<i>Estimated Disk Capacity</i>							
	<b>1 sec.</b>	<b>5 sec.</b>	<b>10 sec.</b>	<b>30 sec.</b>	<b>1 min.</b>	<b>10 min.</b>	<b>30 min.</b>	<b>1 hour</b>
<b>2</b>	13.5 days	2.2 mos.	4.5 mos.	1.1 yrs.	2.2 yrs.	22.2 yrs.	66.8 yrs.	133.7 yrs.
<b>4</b>	8.1 days	1.3 mos.	2.7 mos.	8.1 mos.	1.3 yrs.	13.3 yrs.	40.1 yrs.	80.2 yrs.
<b>6</b>	5.9 days	29.8 days	1.9 mos.	5.9 mos.	11.9 mos.	9.8 yrs.	29.4 yrs.	58.8 yrs.
<b>8</b>	4.8 days	24.4 days	1.6 mos.	4.8 mos.	9.7 mos.	8.0 yrs.	24.0 yrs.	48.1 yrs.
<b>10</b>	3.7 days	18.9 days	1.2 mos.	3.7 mos.	7.5 mos.	6.2 yrs.	18.7 yrs.	37.4 yrs.
<b>12</b>	3.2 days	16.2 days	1.0 mo.	3.2 mos.	6.5 mos.	5.3 yrs.	16.0 yrs.	32.1 yrs.

**Batch Control**

Specify a discrete parameter as the START/STOP switch for all data types whose storage mode is set to "BATCH".

**ATTENTION**

If no BATCH CONTROL parameter is defined here, batch storage is started/stopped instead through the menu item BATCH STATE. If a parameter is defined here, BATCH STATE menu item is disabled.

**Format Disk**

Place a 1.44 megabyte floppy disk in the drive, select this line and press Enter. The message PRESS ENTER TO FORMAT will appear. Press Enter to format or press Menu to cancel formatting. The message FORMATTING DISK will appear until formatting is complete. Press any button to cancel formatting. When formatting is complete, the message FORMAT COMPLETE will appear.

120 megabyte disks can not be formatted with this prompt.

**Warning Level %**

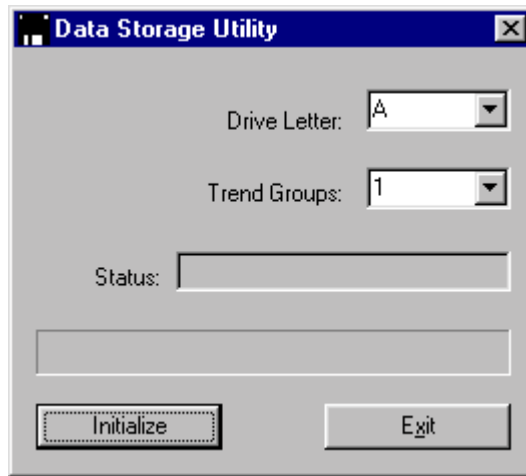
Select 0-99%. When any data set reaches this % of full capacity, the instrument will display the "DISK WARNING" message.

**Preinitialize 120MB/Zip disk with DSU**

On instruments with a 120MB and Zip drives, preinitialize the disk using DSU software (shipped on a separate disk). Using DSU will save you hours of waiting when you Initialize Disk. 1.44MB disk users skip to Initializing Disk.

**ATTENTION**

LS120 Superdrive or Zip drive must be installed on your PC to run DSU.



**Table 4-77 120MB/Zip Preinitialization Procedure**

Step	Action
1	Insert the 120MB/Zip disk into your PC drive.
2	Run DSU. The dialog box above appears.
3	Click on Drive Letter to specify the drive on your PC (A, B, etc.).
4	Click on Status to see amount of free disk space. Each trend group requires 24MB, so 2 trend groups require 48MB, 3 groups require 72MB. If your disk does not have enough free space, delete some files before continuing.
5	When your disk has enough free space, click on Trend Groups to specify the number of Trend Groups the instrument will store data to (1, 2, or 3).
6	Click on Initialize to prepare the disk for storage. Each trend group takes about two minutes.
7	Exit DSU.
8	Remove disk, insert it into the instrument, and initialize it. See Initializing Disk below.

### Initializing Disk

Initialization activates storage and creates a file for each data set (Trends 1-3, alarms, events, unit data, diagnostics). Filename extensions are as follows.

**Table 4-78 Filename Extensions Of Data Storage Types**

Data set	Extension
Trend 1 data	.LNT
Trend 2 data	.LNT
Trend 3 data	.LNT
Alarms	.LNA
Events	.LNE
Unit Data	.LNU
Diagnostics	.LND

Insert the disk. If you are using a 120MB/Zip disk, it is recommended you first preinitialize the disk with DSU. Select INITIALIZE DISK from DATA STORAGE.

Select USE NEW SCHEDULES to store the new storage schedules. If you choose USE CURRENT SCHEDULES, the disk is initialized using the current setup (the setup from the previous initialization), not the new setup. Typically the operator will choose USE CURRENT SCHEDULES to continue storing the same setup onto a new disk.

### IMPORTANT

Initialization deletes any data already on the disk, therefore, you are prompted to press Enter to proceed or to press Menu to abort.

When the INITIALIZING DISK message disappears, initialization has completed. If initialization fails, see Table 6-8 for message descriptions.



## 5. Setpoint Profiler

### What's in this section?

Section 5 explains the functions, configuration, and operation of the Setpoint Profiler. Terminology is defined and all prompts are explained.

Section	Page
Overview of the Setpoint Profiler	183
Components of a profile	186
Parameters that control a profile's execution	194
How to set up a profiler	200
How to load and run a profiler	208

### 5.1 Overview of the Setpoint Profiler

#### Definitions

A *profiler* is a Setpoint Profiler function block. This function block is what you interact with when you program and run a profile. The profiler is analogous to a compact disk player on a stereo, in that the profiler “plays” a profile. Your instrument contains 1, 2, 3, or 4 profilers, depending on the option ordered.

A *profile* is a series of ramp and soak segments, along with any parameters associated with those segments, such as segment loops, events, and guaranteed soak enables. The setpoint produced by the profile is used by a control loop's Setpoint #2. A profile is also known as a curve or recipe. A profile is analogous to a compact disc, in that the profile is “played” by the profiler. Your instrument contains 1, 2, 3, or 4 profiles, depending on the option ordered.

A *program* is a set of one to four profiles, depending on the instrument. Programs in a single profile instrument contain 1 profile, programs in a two-profile instrument contain 2 profiles, programs in a three-profile instrument contain 3 profiles, and programs in a four-profile instrument contain 4 profiles.

*Guaranteed soak* is a set of parameters that hold the profiler when the deviation between the generated setpoint and either PV is larger than a configured limit.

*Event outputs* are discrete output parameters of the Setpoint Profiler function block. They may be tied to other function blocks such as Discrete Outputs.

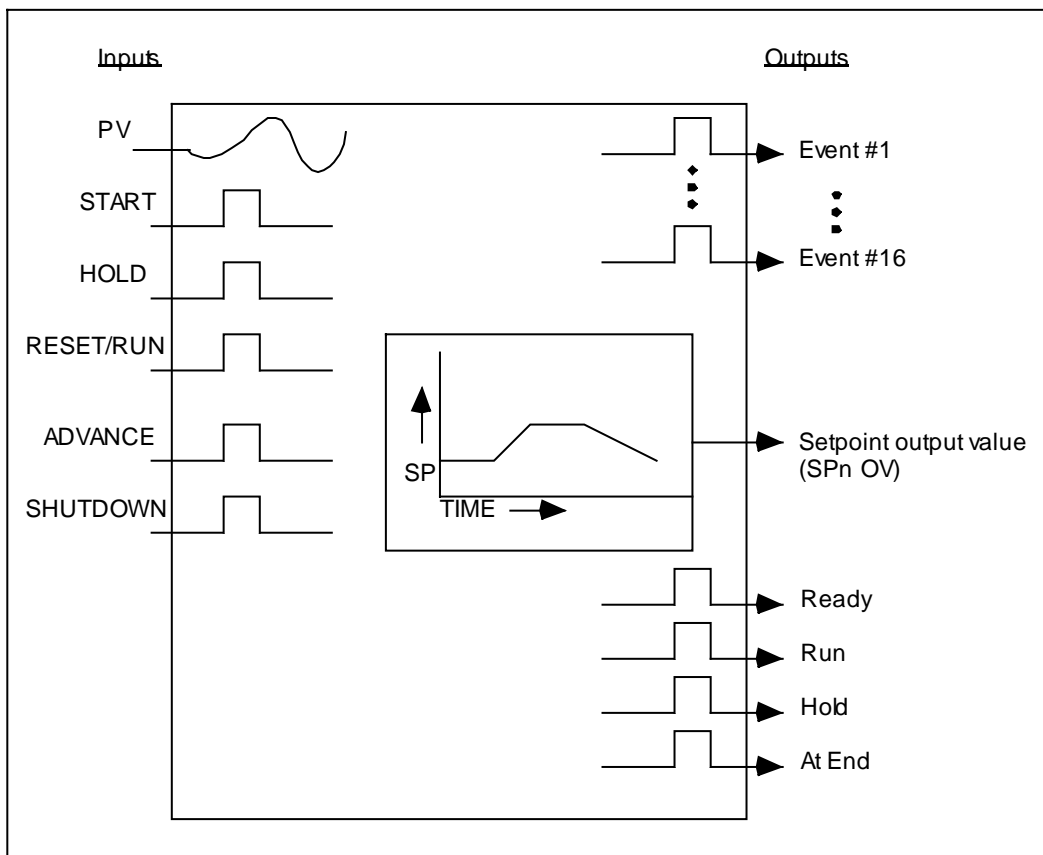
#### Profile features

Each profile has the following features.

- A second PV is available. Each PV is monitored for excessive deviation from the profile value, in which case the profiler can be automatically put on Hold.
- Menu or discrete control of profile resetting, starting, holding, advancing, shutting down, or fast forwarding through the profile.

- Discrete input for starting the profiler at the current value of the process variable. Known as “hot start.”
- Discrete input for enabling/disabling guaranteed soak over the entire profile.
- Guaranteed soak configurable per segment.
- Discrete outputs to indicate profile state, including Ready, Run, Hold, In Progress, and At End.
- Up to 16 Discrete outputs (Events) programmable per segment.
- Four user-selectable methods for ramping.
- Automatic recycling of the profile.
- Up to four levels of looping within profile.
- Jumping to another segment.
- Batch operation, including shutdown profiling, activated through a discrete input or online menu.

**Schematic of the Setpoint Profiler function block**



**Figure 5-1 Setpoint Profiler Schematic**



## Two types of profiles

A *single phase* profile is the simpler of the two profile types. It does not contain startup and shutdown segments. It runs from Segment 1 to the last segment.

A *multi phase* profile divides the profile into three phases: the *startup phase*, the *batch phase*, and the *shutdown phase*. With a multi phase profile you can rerun the batch phase multiple times (known as AUTO CYCLING), or skip to the shutdown phase. The batch phase of a multi phase profile is specified by the BATCH FIRST SEGMENT and BATCH LAST SEGMENT prompts. See Figure 5-2.

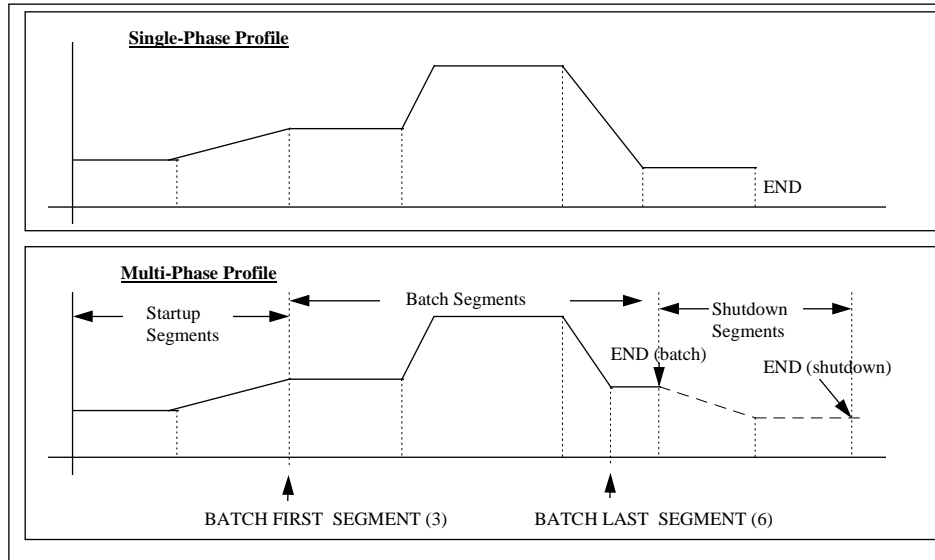


Figure 5-2 Single and Multi-Phase Profiles

## 5.2 Components of a profile

### Two PVs available

Each profile can monitor up to 2 process variables. The second PV is for monitoring a second variable related to your process. The value of each PV is compared with the value of the profile. If the difference between either PV and the profile value exceeds specified amounts, the profiler will Hold (soak), if enabled to do so.

### Number of segments

Up to 63 segments may be in a profile.

### Time Units

All segments use the same time base (seconds, minutes, or hours).

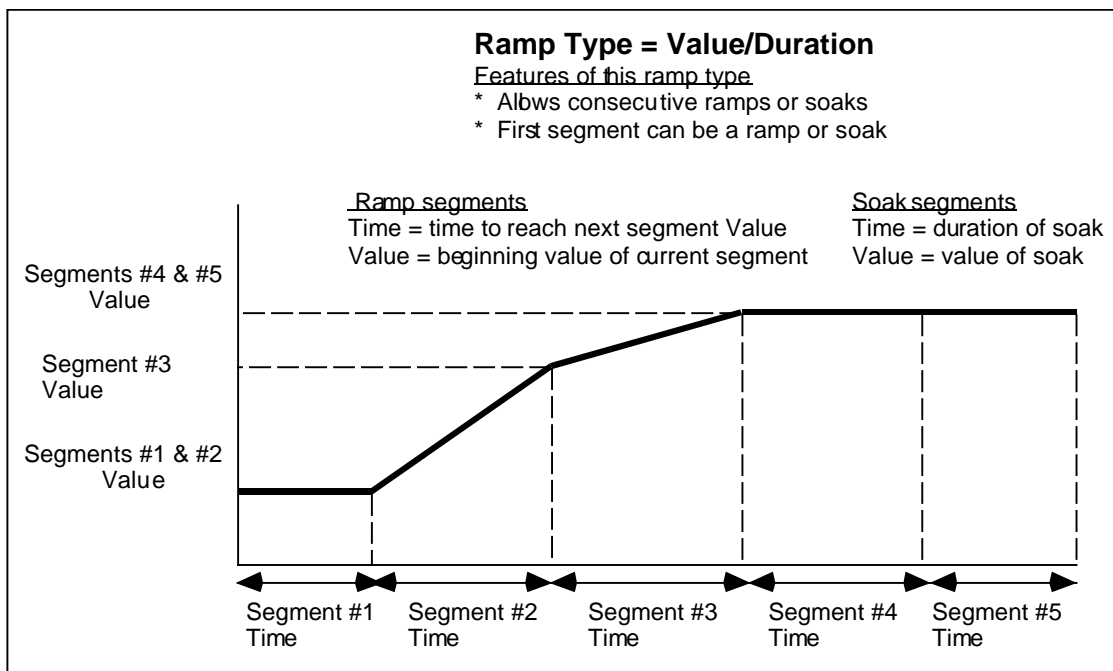
### 4 types of ramp segments

There are four ramp types selectable at the RAMP TYPE prompt.

1. Value/Duration
2. Time
3. Rate
4. External

*Value/Duration (Val/Dur) Ramp Type*

This is the only ramp type that allows consecutive ramps or soaks. VALUE is the beginning value of the segment; TIME is the time needed to reach the VALUE of the next segment.



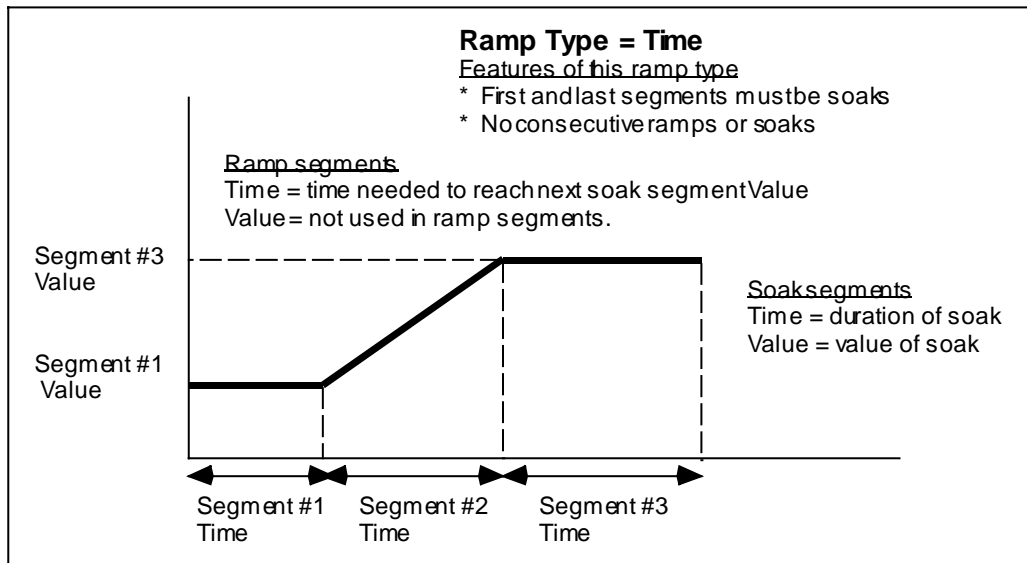
**Figure 5-3 Value/Duration Ramp Type**

To properly terminate a Val/Dur profile you must program the segment *beyond* the last segment with the following:

1. The value you want the program to “end” with. Looking at Figure 5-3, the last segment is a soak, thus the Value of segment #6 should be set to the same value used in segment #5. Any other value will cause segment #5 to be a “ramp” since the value will ramp up (or down) from segment #5’s value to segment #6’s value.
2. Set the TIME to “OFF”.

*Time Ramp Type*

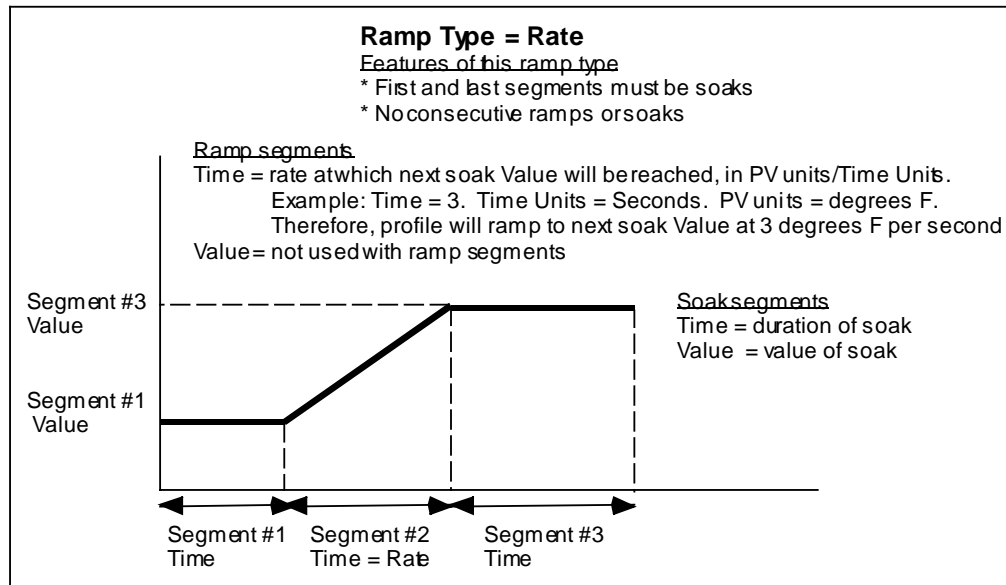
Each ramp segment's TIME is the time allotted for the profiler output to reach the next soak segment's VALUE. The ramp segment's VALUE prompt is not used.



**Figure 5-4 Time Ramp Type**

*Rate Ramp Type*

Each ramp segment's TIME specifies the rate at which the profiler output will reach the next soak segment, where the rate is specified by the prompts TIME/TIME UNITS. The ramp segment's VALUE prompt is not used.



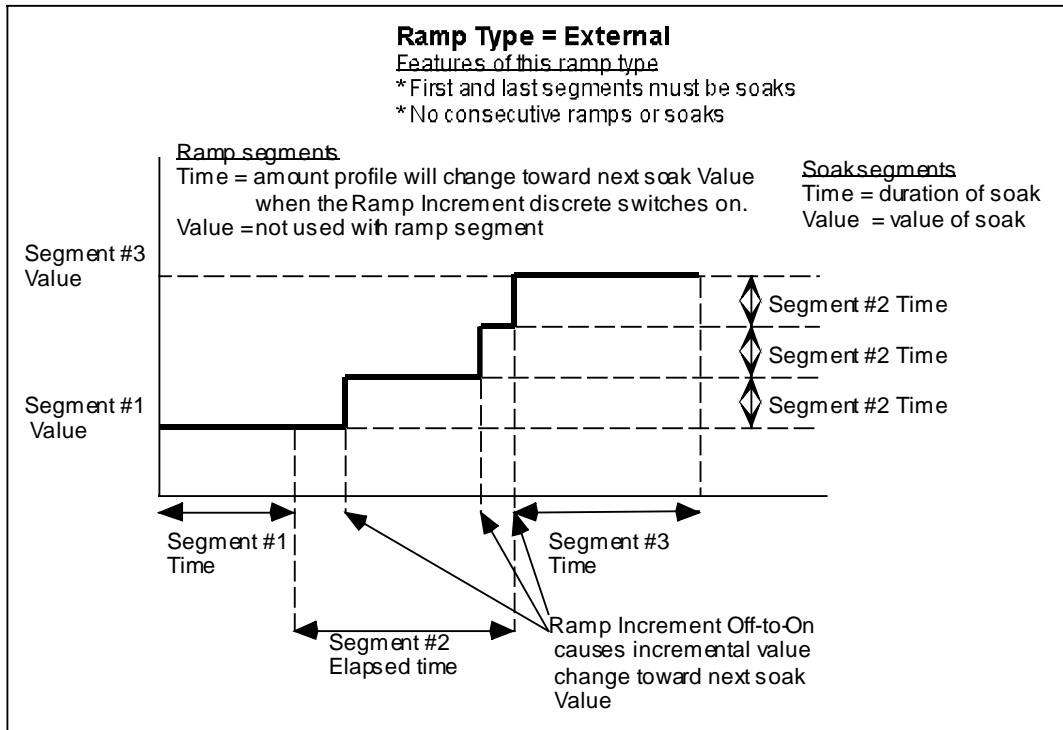
**Figure 5-5 Rate Ramp Type**

**ATTENTION**

Rate ramp type's TIME prompt is in engineering units of the PV, not in time units (seconds, minutes, or hours).

*External Ramp Type*

This ramp type works with the RAMP INCREMENT discrete input. During a ramp segment, each time RAMP INCREMENT changes from OFF to ON, the profiler output incrementally changes by the amount specified in the ramp segment's TIME (in units of the PV). When RAMP INCREMENT changes from ON to OFF, the profiler output soaks at its present value. This increment-soak repeats until the profiler output reaches the VALUE of the next soak segment. The ramp segment's VALUE prompt is not used.



**Figure 5-6 External Ramp Type**

**ATTENTION**

- External ramp type's TIME prompt is in engineering units of the PV, not in time units (seconds, minutes, or hours).
- To increment toward a lower soak value, enter a positive TIME amount. The Setpoint Profiler "knows" to increment or decrement this amount toward the next soak value.

## Soak segment

All soak segments have a beginning VALUE and a TIME during which that value is maintained. This is true regardless of the ramp type used.

## Guaranteed Soak

Guaranteed soak will Hold the profile value if either PV to the profile (typically a Control Loop's PV) deviates specified amounts above or below the profiler output. See Figure 5-7. For a guaranteed soak to occur, the following conditions must be met.

1. The GUAR SOAK #1 and GUAR SOAK #2 prompts for the segment (ramps *and* soaks) must be enabled (set to ON).

and

2. The GUARANTEED SOAK discrete input to the profile must be enabled (level high).

If either of these are disabled, a guaranteed soak cannot occur, even with excessive deviation between profile and PV.

## Hysteresis

This parameter specifies the amount the deviation between profile and PV must be reduced before the profile resumes running after a guaranteed soak. See Figure 5-7.

After a guaranteed soak the profile will resume running when the deviation has decreased by this amount.

The following examples assume GUARANTEED SOAK is ON(1), and the example segment's GUAR SOAK #1 is ON(1).

### Example #1

Assume PV #1 is 20 units above the profile output, GUAR SOAK HI LIM is 15, HYSTERESIS is 5. The profile will Hold because the deviation high limit is exceeded. The profile will resume running when the PV #1 is 10 (15-5) units or less above the profile output.

### Example #2

Assume PV #1 is 20 units below the profile output, GUAR SOAK LO LIM is 15, HYSTERESIS is 5. The profile will Hold because the deviation low limit is exceeded. The profile will resume running when the PV #1 is 10 (15-5) units or less below the profile output.

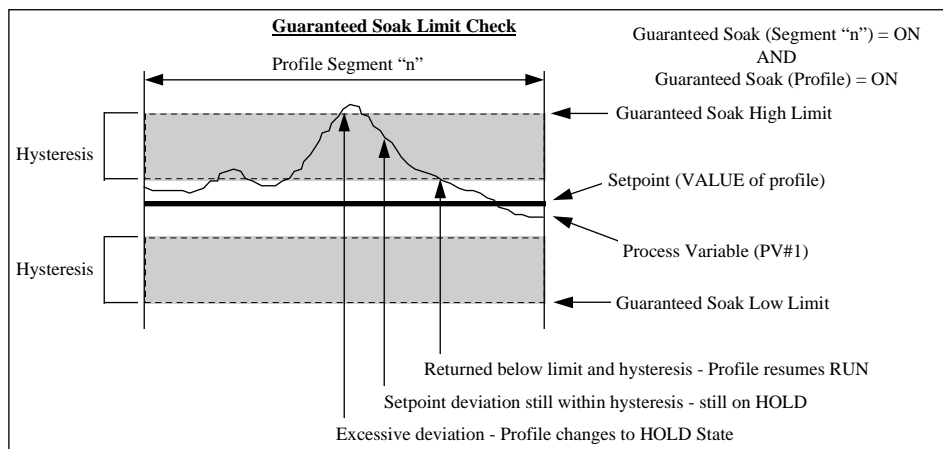


Figure 5-7 Guaranteed Soak and Hysteresis

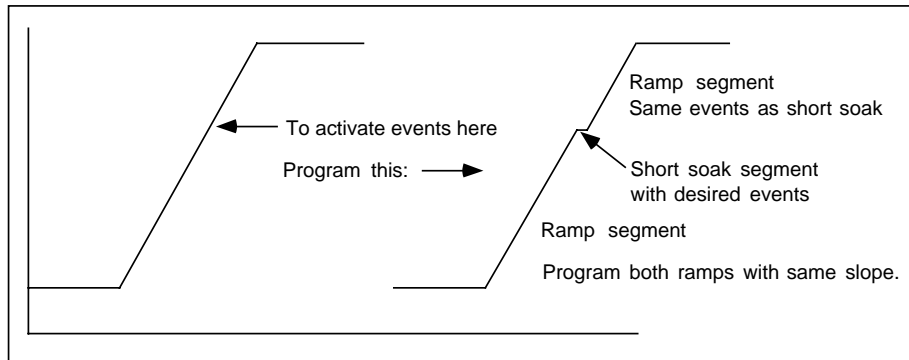
**Segment Events**

Each segment contains 16 programmable discrete event outputs whose ON/OFF states- specified by you - can be used to trigger other discrete functions. The segment’s event states are activated at the beginning of the segment and are maintained unless changed by the next segment in the profile. See Table 5-1. The last segment’s event states are maintained after the profiler is ended.

**Table 5-1 Example of Segment Events**

	Segment #1	Segment #2	Segment #3
<b>Event 1 State</b>	1 (ON)	0 (OFF)	0 (OFF)
<b>Event 2 State</b>	0 (OFF)	1 (ON)	0 (OFF)
<b>Event 3 State</b>	1 (ON)	0 (OFF)	1 (ON)

To activate events in the middle of a ramp segment, replace the desired segment with 3 segments: a ramp, a very short soak, and another ramp. Program the second and third segment events as if they were the middle of the segment.



**Figure 5-8 Activating Events In Mid-Segment**



## Segment Loops

You can program up to four segment loops within a profile. A segment loop is one or more consecutive segments which must repeat a selected number of times before proceeding to the next segment outside of the loop.

Segment loops are specified by the parameters REPEAT COUNT, FROM SEGMENT #, and TO SEGMENT #. Loops are reset when Auto Cycle is reset and when the profile is reset. Loops can contain other loops but cannot overlap.

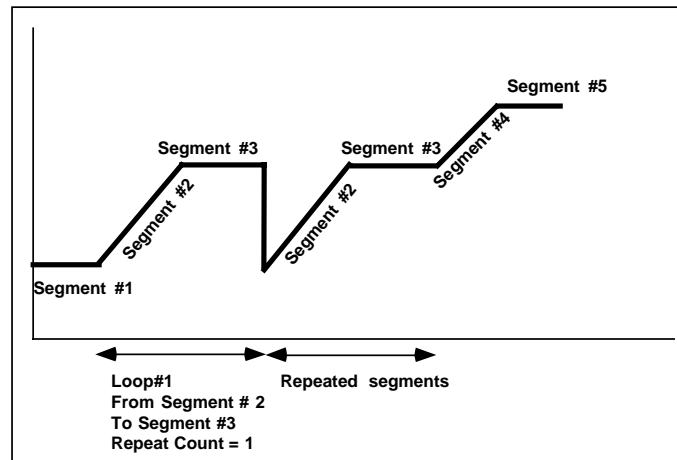


Figure 5-9 Example Of A Segment Loop

### Examples of valid loops

Loop #1: LOOP FROM SEGMENT = 1  
LOOP TO SEGMENT = 10

Loop #2: LOOP FROM SEGMENT = 1  
LOOP TO SEGMENT = 9

Loop #1: LOOP FROM SEGMENT = 1  
LOOP TO SEGMENT = 10

Loop #2: LOOP FROM SEGMENT = 2  
LOOP TO SEGMENT = 10

Loop #1: LOOP FROM SEGMENT = 1  
LOOP TO SEGMENT = 10

Loop #2: LOOP FROM SEGMENT = 2  
LOOP TO SEGMENT = 9

### Example of invalid (overlapping) loops

Loop #1: LOOP FROM SEGMENT = 1  
LOOP TO SEGMENT = 9

Loop #2: LOOP FROM SEGMENT = 2  
LOOP TO SEGMENT = 10

### 5.3 Parameters that control a profile's execution

#### Coordinating operation of multiple profilers

In a multi-profiler instrument the profiles in a program can be totally unrelated to each other, that is, you can give them different times and settings. *If you want the profilers to be coordinated, you must configure each profiler that way.* For example, if you want all your profilers to be started by the same signal, you must configure each profiler with the same START parameter. The Copy Block function in the Program menu lets you copy parameters from one profiler to another.

#### Holding multiple profilers simultaneously

The figure below shows how to configure your instrument to hold all profilers when one or more profilers enters the Hold state because of a guaranteed soak. Also shown is how to configure it to hold or start all profilers by pressing the F2/HOLD key. Note that any profiler can still be put in Hold through the popup profile menu (Table 5-14, page 214 ); doing so will not Hold the other profilers.

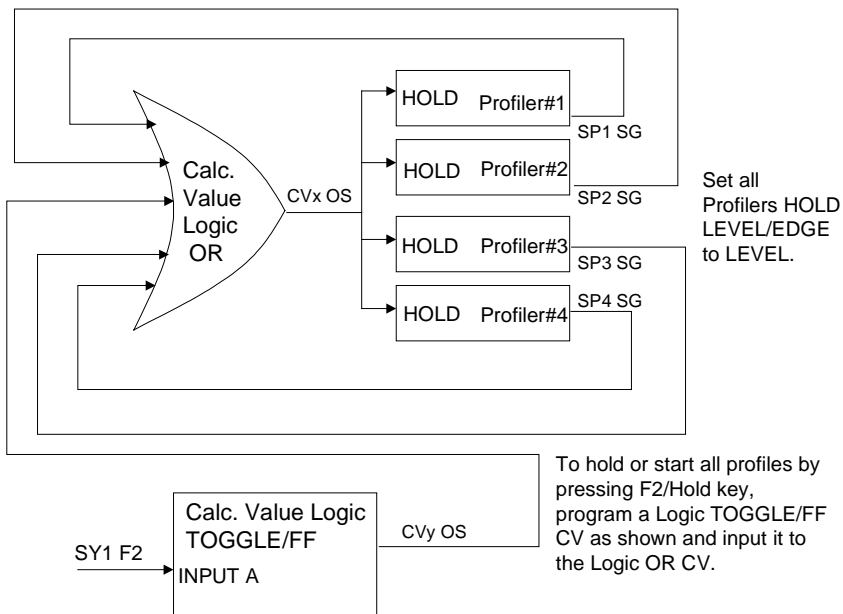


Figure 5-10 Holding multiple profilers simultaneously

## Discrete inputs

You can program a profiler with discrete inputs that enable you to reset, start, hold, advance, shut down, or fast forward through the profiler, hot start the profiler from a live process variable, increment a ramp segment, or enable/disable guaranteed soak. See Table 5-2.

Note that some discretets are *edge-sensitive* and some are *level-sensitive*. Edge-sensitive means that the action is triggered by the discrete's transition from OFF to ON (rising edge) or from ON to OFF (falling edge). The changing status is what triggers the action, not the status itself. Some discretets, such as START, are rising edge-sensitive only and are not affected by a falling edge. When START's discrete goes ON, the profiler starts to run; when the discrete goes OFF, the profiler continues running.

Level-sensitive means that one action occurs while the discrete is ON and another action occurs while the discrete is OFF. The status is what causes the action, not the changing status. Fast forward's discrete is level-sensitive; that is, the profiler will run in fast forward while the discrete is ON but not while it is OFF.

**Table 5-2 Parameters That Control Profiler Execution**

Parameter name	Definition	Triggered by	Conditions present	Result
START	Starts Profiler from Ready, Hold, or End state. Activated by operator menu or by discrete input. May be connected to the START/F1 key (SY1F1).	Rising edge	Profiler in Ready or End state	Profiler starts to Run.
RESET/RUN	The behavior of this parameter depends on START. If the START discrete input is programmed with a discrete, then switching RESET/RUN from OFF to ON resets an Ended, Hold, or Ready profiler to the starting value of segment 1.	Rising edge	Start is programmed with a discrete parameter & profiler is in Ready or Hold or End	Profiler changes to Ready and goes to Segment #1.
	If the START discrete input parameter is <i>not</i> programmed with a discrete, then switching RESET/RUN from OFF to ON resets an Ended, Hold, or Ready program to the starting value of segment 1 and to the profiler's Ready state. On a transition from ON to OFF, starts an Ended profiler.	Rising edge	START is not programmed with a discrete parameter & profiler is in Ready or Hold or End	Profiler changes to Ready and goes to Segment #1.
	RESET/RUN does not affect a running program. May be connected to the RESET/F3 key (SY1F3).	Falling edge	START is not programmed with a discrete parameter & profiler is at End	Profiler goes to Segment #1 and starts to Run.

Table 5-2 Parameters That Control Profiler Execution (continued)

Parameter name	Definition	Triggered by	Conditions present	Result
HOLD	<p>Holds a profiler at its current position. Profiler's Elapsed Time continues but Segment Time stops until Profiler is started again.</p> <p>Hold is activated by online operator menu or by a discrete input's level ON or rising edge. To hold profile by pressing HOLD/F2 key:</p> <ol style="list-style-type: none"> <li>1. Set HOLD to SY1F2.</li> <li>2. Set HOLD LEVEL/EDGE to EDGE.</li> </ol> <p>To hold or start multiple profiles simultaneously, see "Holding multiple profilers simultaneously".</p>	Level ON or Rising Edge (depends on setting of profile's HOLD LEVEL/EDGE prompt)	Profiler is in Run or Hold	Profiler is put in Hold.
HOLD	<p>Holds a profiler at its current position. Profiler's Elapsed Time continues but Segment Time stops until Profiler is started again.</p> <p>Hold is activated by online operator menu or by a discrete input. May be connected to HOLD/F2 key (SY1F2).</p>	Level ON	Profiler is in Run or Hold	Profiler is put in Hold.
ADVANCE	<p>Advances a profiler on Hold to the starting value of the next segment. If the profile is on the last segment, it advances to the ending value of the last segment. If the profile is on the ending value of the last segment of the batch, then it advances around to the starting value of segment 1, or to the first segment of the batch phase as defined by BATCH SEGMENT FIRST. If within a loop, advances to next segment in the loop.</p> <p>Advance is activated by online operator menu or by a discrete input.</p>	Rising edge	Profiler is in Hold	Profiler advances.
HOT START	<p>When HOT START is ON and the profiler is started, the profiler begins to run at the point in the profile where the current value of PV #1 first occurs. Hot Start makes the profiler skip over unneeded segments.</p> <p>Hot Start is activated by a discrete input.</p> <p><u>Example</u></p> <p>If PV #1 is 100 and the profile contains the value 100 in Segment 4 and Segment 6, HOT START forces the profiler to start running at Segment 4 at 100, not at Segment 1 or Segment 6.</p> <p>See Figure 5-11.</p>	Level ON	Profiler is in Ready.	When profiler changes from Ready to Run, profiler jumps to the same value as PV #1.

**Table 5-2 Parameters That Control Profiler Execution (continued)**

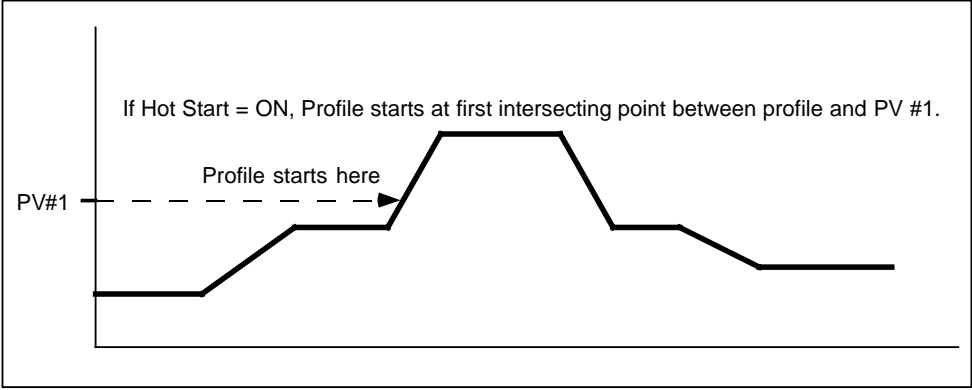
Parameter name	Definition	Triggered by	Conditions present	Result
 <p data-bbox="721 730 997 758"><b>Figure 5-11 Hot Start</b></p>				
<p><b>FAST FORWARD</b></p>	<p>FAST FORWARD is a way to test for proper functioning of the profiler's events and outputs, without having to wait for the profiler to execute at its normal speed.</p> <p>When FAST FORWARD is ON, the profiler will run at a speed determined by the TIME MULTIPLIER parameter. The higher the time multiplier, the faster the profiler will run.</p> <p>Fast Forward is activated by a discrete input.</p> <p><u>Example</u></p> <p>The Programmer is running at a 500 msec scan rate. The TIME MULTIPLIER is set to 60. Therefore the profiler will run 60 times faster than normal. The profiler will increment in (500msec x 60) or 30 second increments. Put another way, every half-second the profiler will advance 30 seconds.</p> <p>See Figure 5-12.</p>	<p>Level ON</p>		<p>When in Run mode, profiler runs at Fast Forward speed.</p>

Table 5-2 Parameters That Control Profiler Execution (continued)

Parameter name	Definition	Triggered by	Conditions present	Result
<p>Values sampled at each scan during fast forward</p> <p>Sample interval 60 x 500 msec = 30 seconds</p> <p>Normal time of segment: 110 seconds    130 seconds    120 seconds Fast forward time: &lt; 2 seconds    &gt; 2 seconds    2 seconds</p> <p>↑ = profile is sampled    ← — = sampled value</p> <p>Time Multiplier = 60 Scan Rate of machine = 500 msec Therefore, every half second the profile is incremented 30 seconds Segment #2 begins between samples. Segment #2's events not recognized until next scan cycle.</p>				
<p><b>Figure 5-12 Fast Forward</b></p>				
<p>SHUTDOWN</p>	<p>When Shutdown is activated by a discrete input or by the operator menu, the profiler jumps from the batch phase to the shutdown phase of a multiphase profile. The shutdown phase begins at the segment defined by the parameter BATCH LAST SEGMENT+1. Shutdown is useful when you need to shut down your process without waiting for the profiler to finish a batch.</p> <p><u>Example</u></p> <p>BATCH FIRST SEGMENT, which specifies the start of the batch phase of the profile, is set at Segment 3. The last segment of the batch phase, BATCH LAST SEGMENT, is set at Segment 7. The last segment of the profile is Segment 9. When SHUTDOWN changes from OFF to ON, the profiler will jump to Segment 8, the first segment of the shutdown phase of the profile.</p> <p>See Figure 5-13</p>	<p>Rising edge</p>	<p>Profiler is in Run, Hold, or End</p>	<p>Profiler jumps to BATCH LAST SEGMENT + 1.</p>

**Table 5-2 Parameters That Control Profiler Execution (continued)**

Parameter name	Definition	Triggered by	Conditions present	Result
<p>The graph illustrates a process profile over time. It is divided into three main sections: Startup Segments, Batch Segments, and Shutdown Segments. The Startup Segments show a ramp up to a steady state. The Batch Segments consist of a ramp up to a higher steady state, followed by a ramp down to a lower steady state. The Shutdown Segments show a ramp down to a final steady state. Key points are marked: BATCH FIRST SEGMENT at the start of the batch ramp up, BATCH LAST SEGMENT at the end of the batch ramp down, END (batch) at the end of the batch steady state, and END (shutdown) at the end of the final steady state.</p>				
<b>Figure 5-13 Shutdown</b>				
RAMP INCREMENT	See External Ramp Type on page 190.	Rising edge	Profiler is in Run mode & RAMP TYPE of profiler is External	Profiler increments by amount specified by the segment's TIME.
GUARANTEED SOAK	See Guaranteed Soak on page 191.	Level ON	Excessive deviation between profiler and PV #1 or PV #2 & the segment's GUAR SOAK #1 or GUAR SOAK #2 is enabled.	Profiler is put on Hold
HOLD LEVEL/EDGE				

## 5.4 How to set up a profiler

Up to 4 profilers can be programmed, depending on the options on your instrument. There are two menus for programming a profiler: PROGRAM PROFILERS in the Program menu, and SETPOINT PROFILES in the Online menu. Both must be accessed to program a profiler. Both menus are described in this section.

### Program Profilers menu (in Program mode)

This menu lets you define various parameters for controlling the profiler's execution. To access the Program Profilers menu:

1. Press the Menu button until a main menu is displayed.
2. Select Set Mode and change the mode to Program.
3. Select Program Profilers.
4. Select a profiler (#1 through #4) to program. Only profilers that are not actively running are selectable.

Table 5-3 briefly describes the prompts for all profilers. For detailed descriptions, refer to Sections 5.2 and 5.3. See Table 4-2 for additional prompts.



Table 5-3 Program Profiler Prompts

Prompt	Range/Selections	Definition
DISPLAY LO LIM	OFF or number	Enter the lower limit for the SP Trend display. Allow for the maximum and minimum Profiler and PV values.
DISPLAY HI LIM	OFF or number	Enter the upper limit for the SP Trend display, allowing for the maximum and minimum Profiler and PV values.
PV #1	OFF, analog parameter, number	Program the profiler to monitor a process variable. PV #1 is trended on the SP Trend display. PV #1 is compared to the profiler's value to determine deviation. Excessive deviation between PV #1 and profiler value can cause a Hold (guaranteed soak).
PV #2	OFF, analog parameter, number	This is an optional PV that can also be monitored and can be used to determine deviation from profiler value. PV #2 is shown on SP Trend display's Point/Detail menu. PV #2 is also trended on SP Trend display.
START	Discrete parameter, 1, 0, or OFF	See Start on page 195.
RESET/RUN	Discrete parameter, 1, 0, or OFF	See Reset/Run on page 195.
HOLD	Discrete parameter, 1, 0, or OFF	See Hold on page 196.
ADVANCE	Discrete parameter, 1, 0, or OFF	See Advance on page 196.
HOT START	Discrete parameter, 1, 0, or OFF	See Hot Start on page 196.
FAST FORWARD	Discrete parameter, 1, 0, or OFF	See Fast Forward on page 197.
SHUTDOWN	Discrete parameter, 1, 0, or OFF	See Shutdown on page 198.
RAMP INCREMENT	Discrete parameter, 1, 0, or OFF	See External Ramp Type on page 190.
GUARANTEED SOAK	Discrete parameter, 1, 0, or OFF	See Guaranteed Soak on page 191.
HOLD LEVEL/EDGE	LEVEL or EDGE	Select LEVEL to Hold the profiler while the Hold discrete is Level ON, and resume Run when the Hold discrete is Level OFF.  Select EDGE to Hold the profiler after the Hold discrete changes from OFF to ON, and resume Run after the Start discrete changes from OFF to ON.

**Setpoint Profiles Menu (in Online mode)**

This menu lets you define profile ramp and soak segments and associated parameters, and store and load programs to and from floppy disk or memory. See

Figure 5-14 for allowable and non-allowable storage.

To access the Setpoint Profiles menu:

1. Press the Menu button until a main menu is displayed.
2. Select Set Mode and change the mode to Online.
3. Select Setpoint Profiles.
4. Select a profile (#1 through #4) to program.

Table 5-4, Table 5-5, and Table 5-6 describe the Setpoint Profile prompts.

**Table 5-4 Setpoint Profiles Prompts**

Prompt	Range/Selections	Definition
EDIT PROFILE #1 EDIT PROFILE #2 EDIT PROFILE #3 EDIT PROFILE #4		Select a profile to edit. See Table 5-5 for prompts.
STORE PROGRAM TO DISK	STARTING PROFILE #	Select 1-4.  Select the lowest numbered profile to be stored; that is, Profile 1, 2, 3, or 4. See <i>How programs are stored on a disk</i> on page 211 for details.
	NUMBER OF PROFILES	Select 1-4.  Number of profiles (1, 2, 3, or 4) determines how many profiles will be stored, starting with the Starting Profile #. For example, if Starting Profile # is 1 and Number of profiles is 3, then Profiles 1, 2, and 3 are stored. See <i>How programs are stored on a disk</i> on page 211 for details.
	FILE	Select the filename and number. Filename extension is .LNS. After you select the number and press Enter, the profile(s) are stored to disk.
	FILES ON DISK	Lists all files on the disk.
STORE PROGRAM TO MEMORY	PROGRAM NUMBER	Select 1-12.  On the VPR, there are up to 96 "slots" allotted for profile memory storage. Depending on how many profiles your instrument has, each program will contain a certain number of profiles. See <i>How programs are stored to memory</i> on page 209 for details.
	STORE PROGRAM TO MEMORY	Select this to store program to memory.

Table 5-4 Setpoint Profiles Prompts (continued)

Prompt	Range/Selections	Definition
LOAD PROGRAM FROM DISK	Files with .LNS extension.	Select a program to load into the Setpoint Profiler function block. Press Enter to load. Existing profiles in the instrument will be replaced by the profiles in the program being loaded.  <u>Example</u>  You are loading Program1.LNS which contains Profiles #1, #2, and #3. These profiles will replace the profiles currently set up in the instrument. Profile #4 will not be replaced.
LOAD PROGRAM FROM MEMORY	PROGRAM NUMBER	Select a program 1-96 to load into the Setpoint Profiler function block.  There are up to 96 "slots" allotted for program memory storage. Depending on how many profiles your instrument has, each program will contain a certain number of profiles.  <i>See How programs are stored in memory on page 209 for details.</i>

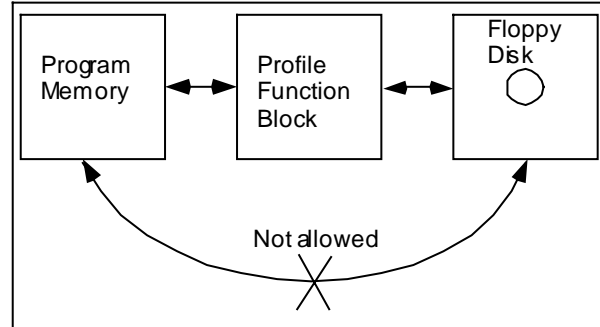


Figure 5-14 Allowable and Non-Allowable Program Storage

Table 5-5 Edit Profile Prompts

Prompt	Range/Selections	Definition
RAMP TYPE	VAL/DUR, TIME, RATE, EXTERNAL	See <i>4 types of ramp segments</i> on page 186.
TIME UNITS	SECS, MINS, HOURS	Select the time units to be used by all segments of the profile.
EDIT SEGMENTS		See Table 5-6.
GUAR SOAK LO LIM	OFF or number	The profiler will Hold if PV #1 or PV #2 deviates more than this much below the profiler output. See <i>Guaranteed Soak</i> on page 191 for details.
GUAR SOAK HI LIM	OFF or number	The profiler will Hold if PV #1 or PV #2 deviates more than this much above the profiler output. See <i>Guaranteed Soak</i> on page 191 for details.
HYSTERESIS	OFF or number	See <i>Hysteresis</i> on page 191 for details.
BATCH FIRST SEGMENT	0-63	Specify the first segment of the batch phase. Prior segments are the start-up phase. A value of 0 indicates a single phase profile. See <i>Two types of profiles</i> on page 185 for details.
BATCH LAST SEGMENT	0-63	Specify the last segment of the batch phase. Segments after this segment are the shutdown phase. A value of 0 indicates a single phase profile. See <i>Two types of profiles</i> on page 185 for details.

(continued)

Table 5-5 Edit Profile Prompts (continued)

Prompt	Range/Selections	Definition
AUTO CYCLE	OFF, ON	<p>Select ON to have the profile (or batch phase if defined) repeat AUTO CYCLE COUNT times.</p> <p>Automatically re-runs the profile when ON. The parameter AUTO CYCLE COUNT controls the number of additional cycles through the profile. When AUTO CYCLE is ON and AUTO CYCLE COUNT is zero (0), the profile will cycle forever.</p> <p>For a single phase profile, the profiler must progress to the END state before cycling back to segment 1. Once the profiler is ENDED, the automatic cycling function will change the profiler to the READY state for one machine cycle (clearing the profiler's discrete outputs) before proceeding to the RUN state. The elapsed time of the profiler will continue due to re-cycling.</p> <p>For a multi-phase profile, the profiler must progress to the END state following segment BATCH LAST SEGMENT before cycling back to the BATCH FIRST SEGMENT. Once the profiler is ENDED, the automatic cycling function will change the profiler to the RUN state. The elapsed time of the profiler will continue running during recycling.</p>
AUTO CYCLE COUNT	0-254	<p>0: the profile (or batch) will repeat forever.</p> <p>1-254: the profile (or batch) will repeat this many times.</p>
EDIT PROFILE LOOPS	LOOP #1-4 FROM SEGMENT # 1-63 TO SEGMENT # 1-63 REPEAT COUNT 1-999	<p>Define up to 4 loops per profile. Note that the repeat count is the number of loop repetitions, not the number of loop executions. See <i>Loop Segments</i> on page 193 for details.</p>
JUMP FROM SEGMENT	0-63	<p>The profile can be forced to jump from any segment to any other segment. A jump within a loop will continue that loop. A jump outside a loop will exhaust that loop. A jump outside the batch phase will exhaust any auto cycling in effect.</p> <p>At the completion of this segment, the profiler will jump to the beginning of JUMP TO SEGMENT.</p>
JUMP TO SEGMENT	0-63	<p>At the completion of JUMP FROM SEGMENT, the profiler will jump to the beginning of this segment.</p>

**Table 5-5 Edit Profile Prompts** (continued)

Prompt	Range/Selections	Definition
TIME MULTIPLIER	Number	<p>Time Multiplier determines the speed at which the profiler will run when in Fast Forward mode. It is used for testing the profiler's execution. See Fast Forward.</p> <p>When FAST FORWARD is ON(1), the profiler will run at a speed determined by the TIME MULTIPLIER parameter.</p> <p><u>Example</u></p> <p>The instrument is running at a 500msec scan rate. The TIME MULTIPLIER is set to 60. Therefore the profiler will run in (500msec x 60) or 30 second increments.</p> <p>Running a profiler in FAST FORWARD is a way to check for proper functioning of the profiler's events and outputs, without having to wait for the profiler to execute at its normal speed.</p> <p>See Figure 5-12.</p>

## Editing Segments

Use the following prompts to map out each segment's value, time, and events. Up to 63 segments are programmable per profile.

**Table 5-6 Edit Segments Prompts**

Prompt	Range/Selections	Definition
NEXT SEGMENT		Select this to edit the next segment.
PREVIOUS SEGMENT		Select this to edit the previous segment
VALUE	OFF or number	This prompt is active for soak segments and value/duration ramp types. Enter the value of the segment.
AUX VALUE	OFF or number	This value is an auxiliary soak output of the profile. The output is identified as SPn A1 and remains constant for the duration of the segment.
TIME	OFF or Positive number	The purpose of the number entered here depends on the ramp type of the profile. See <i>4 types of ramp segments</i> on page 186 for details.
GUAR SOAK #1	ON or OFF	ON means the profiler will Hold during this segment if deviation between PV #1 and the profiler output exceeds the guaranteed soak limits in Table 5-5. OFF means the profiler will not Hold during this segment due to deviation. See <i>Guaranteed Soak</i> on page 191 for details.
GUAR SOAK #2	ON or OFF	ON means the profiler will Hold during this segment if deviation between PV #2 and the profiler output exceeds the guaranteed soak limits in Table 5-5. OFF means the profiler will not Hold during this segment due to deviation. See <i>Guaranteed Soak</i> on page 191 for details.
EDIT EVENTS	EVENT #1 . . . EVENT #16	Enter the state of up to 16 discrete outputs of this segment. These outputs can be used to trigger any action requiring a discrete signal, such as a relay or another function block.  An event stays on or off for the entire segment.  To trigger events in the middle of a segment, you must divide the segment into 3 segments. See <i>Segment Events</i> on page 192 for details.

## 5.5 How to load and run a profiler

### Overview

From the Setpoint Profile Trend's menu you can:

- load a profiler from memory (VPR and VRX 150 only)
- load a profiler from floppy disk
- start a profiler
- hold a profiler
- reset a profiler
- advance a profiler
- shut down a profiler
- view profiler events
- view profiler details (profiler elapsed time, segment time remaining, profiler length in seconds, PV #2 value)
- edit profile segments,
- view various profiler displays.

All these tasks can be done using the front panel buttons shown in Figure 5-15. The procedures are explained in the next several pages.

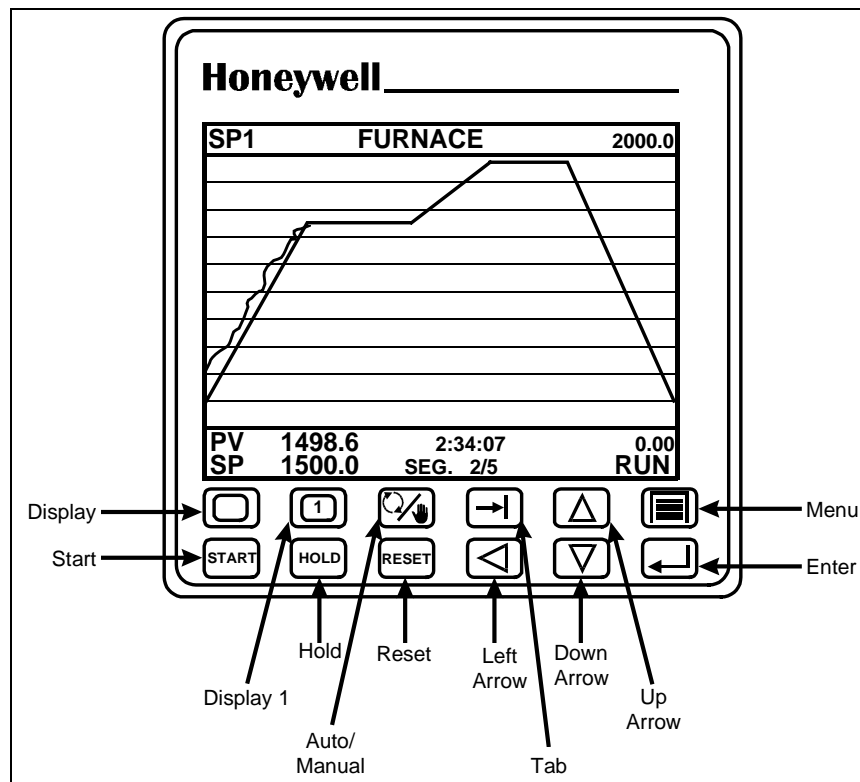


Figure 5-15 VPR Buttons



**ATTENTION**

The following procedures assume the instrument has been programmed to display the Setpoint Profiler as a trend. To program displays, see section 4.18 Program Displays.

**How to load programs from memory using Online menu**

In the VPR100 and VRX150 only, programs can be saved to internal memory and can be retrieved. Programs stored in memory are identified by number (1-96) depending on instrument model number. Each program stored in memory contains one to four profiles, depending on your instrument. See Table 5-7.

For example, on an instrument with 3 profiles, you can stored Program #1 which contains Profiles #1, #2, and #3.

**Table 5-7 How Profiles Are Stored In Memory (VPR100/VRX150 only)**

1-programmer instrument 1 Profile per Program		2-programmer instrument 2 Profiles per Program		3-programmer instrument 3 Profiles per Program		4-programmer instrument 4 Profiles per Program	
This Program...	...contains this Profile	This Program...	...contains these Profiles	This Program...	...contains these Profiles	This Program...	...contains these Profiles
1	1	1	1	1	1	1	1
2	1		2		2		2
3	1	2	1		3		3
4	1		2	2	4		
5	1	3	1	2	1	2	1
6	1		2		2		2
7	1	4	1		3		1
8	1		2	2			4
9	1	5	1	4		1	3
10	1		2		2	2	
11	1		6	1	3	2	
12	1	2		3		4	
•		•		•			•
•		•		•		•	
•		•		•		•	
93	1	47	1	32	1	24	1
94	1		2		2		2
95	1	48	1		3		3
96	1		2	3	4		

**Table 5-8 Procedure To Load A Program From Memory Using Online Menu (VPR100/VRX150 only)**

Step	Action	Result/Notes
1	If instrument is not in online mode, press the Display button to change to online mode.	An online display is shown.
2	Press the Menu button to display the online menu.	Online menu is displayed.
3	Press Down Arrow button to highlight Setpoint Profiles.	Cursor moves down.
4	Press Enter.	Setpoint Profiles menu is displayed.
5	Press Down Arrow button to highlight Load Program From Memory.	Prompt is highlighted.
6	Press Enter.	Load Program sub-menu is displayed.
7	Press Enter to select Program Number prompt.	Cursor moves to the right.
8	Press Up Arrow or Down Arrow to select the desired program number to be loaded.	Program number is displayed.
9	Press Enter to select	Program number is selected.
10	Press Enter again to load.	Program is loaded from memory to the instrument.

**Table 5-9 Procedure To Load A Program From Memory Using Any Profiler Display (VPR100/VRX150)**

Step	Action	Result/Notes
1	If instrument is not in online mode, press the Display button to change to online mode.	An online display is shown.
2	Access the Setpoint Profile Trend display: Press the Display button until the Setpoint Profile Trend display is shown.  Or Press the Display button until a Setpoint Bar Graph display is shown. Press the Tab button to move the cursor to the TREND text under the desired profile at the bottom of the display. Press Enter to display the Setpoint Profile Trend display for that profile.	Setpoint Profile Trend display is shown.
3	Press the Tab button to display the profiler menu.	Profiler menu is shown.
4	Press Down Arrow button to highlight LOAD.	Cursor moves down to LOAD menu item.
5	Press Enter.	LOAD menu is displayed.
6	Press Enter to select Program Number prompt.	Cursor moves to the right.
7	Press Up Arrow or Down Arrow to select the desired program number to be loaded.	Program number is displayed.
8	Press Enter.	Program number is selected.
9	Press Down Arrow to highlight LOAD PROGRAM FROM MEMORY.	Cursor is on LOAD PROGRAM FROM MEMORY.
10	Press Enter to select it.	Specified Program is loaded from the internal memory to the specified Profiler.

## How programs are stored on a disk

Programs are saved to disk as a file name, number, and .LNS extension. Unlike memory storage, you can specify which profiles you want stored as a program. Disk capacity depends on the number of profiles in the program. See Table 5-11.

For example, on a 4 Programmer instrument, if you want to store Profiles #2, #3, and #4 as a program, you enter 2 at the prompt STARTING PROFILE #, to indicate that the lowest numbered profile to be stored will be Profile #2. At the prompt NUMBER OF PROFILES, you enter 3 to indicate that 3 profiles will be stored. Table 5-10 shows all possible combinations of profiles that can be stored to disk.

**Table 5-10 How Profiles Are Stored On Disk**

1 Programmer Instrument 1 Profile per Program			2 Programmer Instrument Up to 2 Profiles per Program			3 Programmer Instrument Up to 3 Profiles per Program			4 Programmer Instrument Up to 4 Profiles per Program		
Starting Profile #	Number of Profiles	Program contains this profile	Starting Profile #	Number of Profiles	Program contains these profiles	Starting Profile #	Number of Profiles	Program contains these profiles	Starting Profile #	Number of Profiles	Program contains these profiles
1	1	1	1	1	1	1	1	1	1	1	1
			2	1	2	2	1	2	2	1	2
			1	2	1, 2	3	1	3	3	1	3
						1	2	1, 2	4	1	4
						2	2	2, 3	1	2	1, 2
						1	3	1, 2, 3	2	2	2, 3
									3	2	3, 4
									1	3	1, 2, 3
									2	3	2, 3, 4
									1	4	1, 2, 3, 4

**Table 5-11 Disk Program Capacity**

Number of Profiles in Program	Maximum Disk Capacity
1	224 programs
2	199 programs
3	138 programs
4	100 programs

## How to load a program from disk

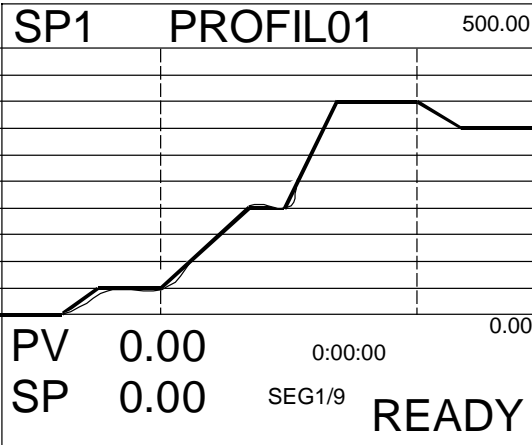
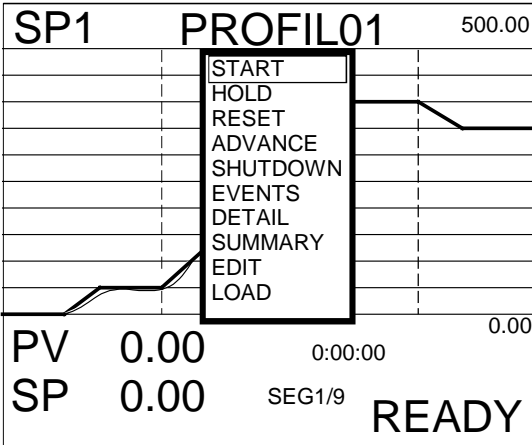
Table 5-12 Procedure To Load A Program From Disk

Step	Action	Result/Notes
1	Press the Display button to change to online mode.	An online display is shown.
2	Press the Menu button to display the online menu.	Online menu is displayed.
3	Press Down Arrow button to highlight Setpoint Profiles.	Cursor moves down.
4	Press Enter.	Setpoint Profiles menu is displayed.
5	Press Down Arrow button to highlight Load Program From Disk.	Prompt is highlighted.
6	Press Enter.	Load Program sub-menu is displayed.
7	Press Up Arrow or Down Arrow to highlight desired program file.	Program is highlighted.
8	Press Enter to select. Press Enter again to load.	Program is loaded from the disk to the instrument.

### How to start a profiler

A profiler can be started from the Ready, Hold or End state.

**Table 5-13 Profiler Starting Procedure**

Step	Action	Result/Notes
1	<p>Press Display button until the Setpoint Trend is displayed.</p> <p>Or</p> <p>Press the Display button until a Setpoint Bar Graph display is shown. Press the Tab button to move the cursor to the TREND text under the desired profile at the bottom of the display. Press Enter to display the Setpoint Profile Trend display for that profile.</p>	
2	<p>Press Tab button to display the profile menu.</p>	
3	<p>Cursor is on Start. Press Enter.</p>	<p>Profiler starts running at segment #1 if in Ready or End or resumes running from its Hold state. If in Ready state and Hot Start has been activated, profiler will start at the first point in the profile where the present value of PV #1 occurs. Event outputs assume their states as of the beginning of the running segment. Profiler status on lower right of display indicates RUN after you start the profiler</p>

### ATTENTION

A profile can also be started by pressing the START or F1 button, but only if that profile's START parameter was configured as SY1 F1. See Section 5.3.

## How to hold a profiler

**Table 5-14 Profiler Hold Procedure**

Step	Action	Result/Notes
1	Perform steps 1 and 2 from Start procedure (Table 5-13).	Profile menu is displayed.
2	Press Down Arrow button to move cursor to Hold. Press Enter.	The profiler is held at its present value and the segment's events are frozen. Elapsed time continues. Run time stops. Events are held at their current states.

### ATTENTION

A profile can also be put on HOLD by pressing the HOLD or F2 button, but only if that profile's HOLD parameter was configured as SY1 F2 and if that profile's HOLD LEVEL/EDGE is set to EDGE. See Section 5.3.

## How to reset a profiler

**Table 5-15 Profiler Reset Procedure**

Step	Action	Result/Notes
1	Place profiler in Hold.	See Profiler Hold procedure in Table 5-14.
1	Perform steps 1 and 2 from Start procedure (Table 5-13).	Profile menu is displayed.
2	Press Down Arrow button to move cursor to Reset. Press Enter.	Profiler is reset to segment #1. All profiler timers are reset. All events go OFF. Profiler output goes to starting value of segment #1.

### ATTENTION

A profile can also be RESET by pressing the RESET or F3 button, but only if that profile's RESET/RUN parameter was configured as SY1 F3. See Section 5.3.

**How to advance a profiler to the next segment****Table 5-16 Profiler Advance Procedure**

<b>Step</b>	<b>Action</b>	<b>Result/Notes</b>
1	Place profiler in Hold.	See Profiler Hold procedure in Table 5-14.
2	Press Down Arrow button to move cursor to Advance. Press Enter.	Profiler advances to next segment. Each press of Enter advances the profiler one segment. If at the last segment, the profiler advances to the first segment. If it is a multiphase profile, the profiler advances within the batch phase only. Events assume their segment states.
3	To resume running the profiler, select Start.	Profile resumes running from the new segment.

**How to shut down a profiler****Table 5-17 Profiler Shutdown Procedure**

<b>Step</b>	<b>Action</b>	<b>Result/Notes</b>
1	Place profiler in Hold by performing Profiler holding procedure (Table 5-14).	See Profiler Hold procedure in Table 5-14.
2	Press Down Arrow button to move cursor to Shutdown. Press Enter.	Profiler advances to the shutdown phase.
3	To resume running the profiler, select Start.	Profile resumes running from the beginning of the shutdown phase.

How to view event status

**Table 5-18 Event Viewing Procedure**

Step	Action	Result/Notes																		
1	Perform steps 1 and 2 from Start procedure (Table 5-13).	Profile menu is displayed.																		
2	Press Down Arrow button to move cursor to Events. Press Enter.	<p>Live On/off status of all 16 events are displayed. If Events change status, they do so at the beginning of the segment and Hold the status during the entire segment.</p> <table border="1" style="margin-left: auto; margin-right: auto;"> <thead> <tr> <th colspan="2">EVENTS</th> </tr> </thead> <tbody> <tr> <td>1-ON</td> <td>9-OFF</td> </tr> <tr> <td>2-ON</td> <td>10-OFF</td> </tr> <tr> <td>3-OFF</td> <td>11-OFF</td> </tr> <tr> <td>4-OFF</td> <td>12-OFF</td> </tr> <tr> <td>5-OFF</td> <td>13-OFF</td> </tr> <tr> <td>6-OFF</td> <td>14-OFF</td> </tr> <tr> <td>7-OFF</td> <td>15-OFF</td> </tr> <tr> <td>8-OFF</td> <td>16-OFF</td> </tr> </tbody> </table>	EVENTS		1-ON	9-OFF	2-ON	10-OFF	3-OFF	11-OFF	4-OFF	12-OFF	5-OFF	13-OFF	6-OFF	14-OFF	7-OFF	15-OFF	8-OFF	16-OFF
EVENTS																				
1-ON	9-OFF																			
2-ON	10-OFF																			
3-OFF	11-OFF																			
4-OFF	12-OFF																			
5-OFF	13-OFF																			
6-OFF	14-OFF																			
7-OFF	15-OFF																			
8-OFF	16-OFF																			

How to view profiler details

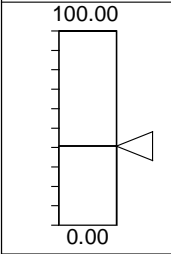
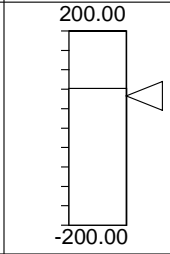
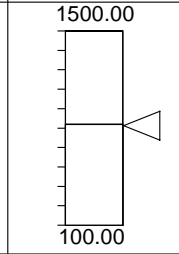
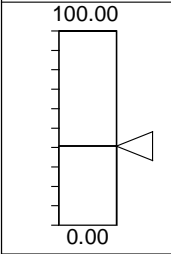
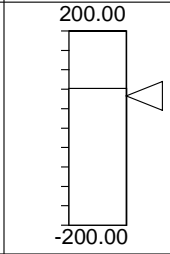
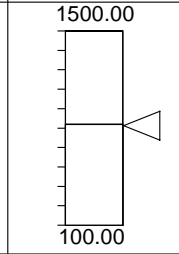
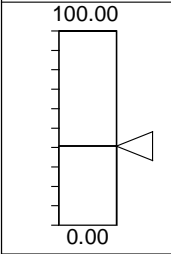
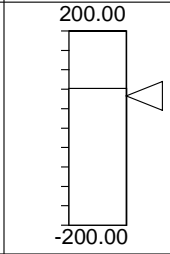
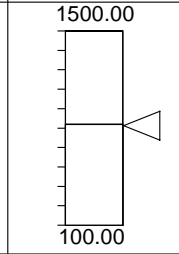
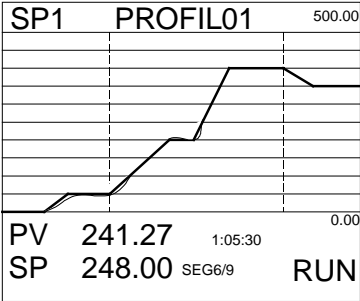
**Table 5-19 Details Viewing Procedure**

Step	Action	Result/Notes								
1	Perform steps 1 and 2 from Start procedure (Table 5-13).	Profiler menu is displayed.								
2	Press Down Arrow button to move cursor to Detail. Press Enter.	<p>Shows:</p> <ul style="list-style-type: none"> <li>Elapsed time since profile was started, including time spent in Hold.</li> <li>Segment time remaining.</li> <li>Profile length in seconds.</li> <li>PV #2 value.</li> </ul> <table border="1" style="margin-left: auto; margin-right: auto;"> <tbody> <tr> <td><b>PV #2</b></td> <td><b>538.67</b></td> </tr> <tr> <td><b>ELAPSED TIME</b></td> <td><b>1:10:56</b></td> </tr> <tr> <td><b>STIME REMAIN</b></td> <td><b>0:09:10</b></td> </tr> <tr> <td><b>LENGTH (SECS)</b></td> <td><b>3900</b></td> </tr> </tbody> </table>	<b>PV #2</b>	<b>538.67</b>	<b>ELAPSED TIME</b>	<b>1:10:56</b>	<b>STIME REMAIN</b>	<b>0:09:10</b>	<b>LENGTH (SECS)</b>	<b>3900</b>
<b>PV #2</b>	<b>538.67</b>									
<b>ELAPSED TIME</b>	<b>1:10:56</b>									
<b>STIME REMAIN</b>	<b>0:09:10</b>									
<b>LENGTH (SECS)</b>	<b>3900</b>									



How to view profiler summary display

Table 5-20 Summary Viewing Procedure

Step	Action	Result/Notes									
1	Perform steps 1 and 2 from Start procedure (Table 5-13).	Profiler menu is displayed.									
2	Press Down Arrow button to move cursor to Summary. Press Enter.	<p>Three profilers will be displayed as bar graphs. Data for your profile(s) will be displayed.</p> <table border="1" data-bbox="932 495 1446 926"> <thead> <tr> <th data-bbox="932 495 1101 537">SP1</th> <th data-bbox="1101 495 1269 537">SP2</th> <th data-bbox="1269 495 1446 537">SP3</th> </tr> </thead> <tbody> <tr> <td data-bbox="932 537 1101 789"> <p>100.00</p>  <p>0.00</p> </td> <td data-bbox="1101 537 1269 789"> <p>200.00</p>  <p>-200.00</p> </td> <td data-bbox="1269 537 1446 789"> <p>1500.00</p>  <p>100.00</p> </td> </tr> <tr> <td data-bbox="932 789 1101 926"> <p>RUN 40.00 SEG 5 00:21:13 TREND</p> </td> <td data-bbox="1101 789 1269 926"> <p>READY 71.00 SEG 1 00:00:00 TREND</p> </td> <td data-bbox="1269 789 1446 926"> <p>END 820.20 SEG 15 01:30:00 TREND</p> </td> </tr> </tbody> </table> <p><b>Setpoint Profiler 3 Bar Summary (SPP_3BS)</b></p>	SP1	SP2	SP3	<p>100.00</p>  <p>0.00</p>	<p>200.00</p>  <p>-200.00</p>	<p>1500.00</p>  <p>100.00</p>	<p>RUN 40.00 SEG 5 00:21:13 TREND</p>	<p>READY 71.00 SEG 1 00:00:00 TREND</p>	<p>END 820.20 SEG 15 01:30:00 TREND</p>
SP1	SP2	SP3									
<p>100.00</p>  <p>0.00</p>	<p>200.00</p>  <p>-200.00</p>	<p>1500.00</p>  <p>100.00</p>									
<p>RUN 40.00 SEG 5 00:21:13 TREND</p>	<p>READY 71.00 SEG 1 00:00:00 TREND</p>	<p>END 820.20 SEG 15 01:30:00 TREND</p>									
3	Press the Tab button to move the cursor to the TREND of the desired profiler, then press Enter.	<p>The profiler trend of the selected profile is displayed.</p>  <p>SP1 PROFIL01 500.00</p> <p>PV 241.27 1:05:30 0.00</p> <p>SP 248.00 SEG6/9 RUN</p>									

## How to edit a profile's segments

Profile may be in Ready, End, or Hold to edit segments.

### CAUTION




For value duration ramp type, it is recommended you do not edit the currently running segment or the next segment. Doing so may prematurely terminate the segment, that is, the profiler may jump to the next segment.

**Table 5-21 Segment Editing Procedure**

Step	Action	Result/Notes
1	Perform steps 1 and 2 from Start procedure (Table 5-13).	Profiler menu is displayed.
2	Press Down Arrow button to move cursor to Edit. Press Enter.	The Edit Profile menu is displayed: <b>EDIT PROFILE #n</b> <b>SEGMENT #n</b> <hr/> <b>NEXT SEGMENT</b> <b>PREVIOUS SEGMENT</b> <b>VALUE            100.00</b> <b>AUX VALUE      50.00</b> <b>TIME             20.000</b>  The profile and segment numbers whose value and time you are editing are shown.
3	Use Up Arrow and Down Arrow buttons to move cursor to value or time. Press Enter to access the numbers shown. Change the numbers with the Up Arrow and Down Arrow buttons.	Numbers are changed to their new values.
4	Press Menu button when finished editing segments.	The Profile Trend is displayed with the new segments.

## 6. Online Operations Using Primary Displays

### 6.1 Overview

Online operation using primary displays consists of using the buttons to view and interact with the displays that were assigned to the buttons Display  and Display 1 . The VRX 100 can have an optional Display 2 button . (To assign displays to these buttons, see section 4.18 Program Displays.) On the VRX150 with no control, the Auto/Manual key functions as the Display 2 key.

Press these buttons to change to online mode and access the displays assigned to this key. Available displays are shown in Figure 4-19 and Figure 4-20 and are described in Table 6-1. In the following table, *interactive* means the Tab button can be pressed to access various functions on the display.

**Table 6-1 Displays Accessed With Display Button**

Display	Function	Interactive or view only?	Page
Setpoint Profiles w/2 Bar Graphs	Displays 2 Profiles' data as bar graphs.	Interactive	221
Setpoint Profiles w/3 Bar Graphs	Displays 3 Profiles' data as bar graphs.	Interactive	221
Setpoint Profiles w/4 Bar Graphs*	Displays 4 Profiles' data as bar graphs.	Interactive	221
Setpoint Profile Trend	Displays a Profile as a Trend.	Interactive	221
Vertical Trend	Displays up to 6 or 12 points trended vertically.	Interactive	222
Vertical Trend Digital	Displays up to 6 or 12 points as trend and digitally.	Interactive	222
Vertical Trend Bar	Display vertical trend with up to 4 bars.	Interactive	222
Horizontal Trend	Displays up to 6 or 12 points trended horizontally.	Interactive	222
Horizontal Trend Digital	Displays up to 6 or 12 points trended horizontally.	Interactive	222
Horizontal Trend Bar	Displays up to 6 or 12 points trended horizontally with 3 or 4 * vertical bar graphs to the right. BAR GRAPH1 = Trend Point 1 BAR GRAPH2 = Trend Point 2 BAR GRAPH3 = Trend Point 3 BAR GRAPH4 = Trend Point 4*	Interactive	222
Panel Display	Rotates through up to 12 points one at a time. Readable from 15 feet (4.6 meters).	Interactive	225
4-Panel Display*	Rotates through up to 12 points four at a time. Readable from 15 feet (4.6 meters).	Interactive	226
Loop w/Bar Graph	Displays a loop's data as numbers and bar graphs.	Interactive	227

*continued*

**Table 6-1 Displays Accessed With Display Button(continued)**

Display	Function	Interactive or view only?	Page
Loop w/2 Bar Graphs	Displays 2 Loops' data as bar graphs.	Interactive	227
Loop w/3 Bar Graphs	Displays 3 Loops' data as bar graphs.	Interactive	227
Loop w/4 Bar Graphs	Displays 4 Loops' data as bar graphs.	Interactive	227
Alarm Summary	Displays current alarms.	Interactive	228
3-point Vertical Bar Graph**	Displays 3 points vertically.	View only	--
4-point Vertical Bar Graph*	Displays 4 points vertically.	View only	--
6-point Vertical Bar Graph*	Displays 6 points vertically.	View only	--
8-point Vertical Bar Graph*	Display 8 points vertically.	View only	--
12-point Vertical Bar Graph*	Displays 12 points vertically.	View only	--
4-point Horizontal Bar Graph*	Displays 4 points horizontally.	View only	--
6-point Horizontal Bar Graph*	Displays 6 points horizontally.	View only	--
Unit Data	Displays up to 12 point values at a time.	View only	--
Panel Meter	Displays up to 12 different panel displays at a time.	View only	--
Storage Status	Displays data storage status.	View only	--
Totalizer	Displays all totalizer values.	View only	--
Process Summary*	Displays simultaneously the following formats: Horizontal Trend Digital Loop w/4 Bar Graphs Panel Meter	View only	--
*VRX150 only			
**VPR100/VRX100 only			

## 6.2 Interacting With Primary Displays

### Interacting with Setpoint Profile Summary Displays

When any Setpoint Profile Summary display is shown (Figure 6-1) press Tab to move cursor to the TREND text below each bar graph, then press Enter to go to the Setpoint Trend display for that profile. See Interacting with Setpoint Trend Display below.

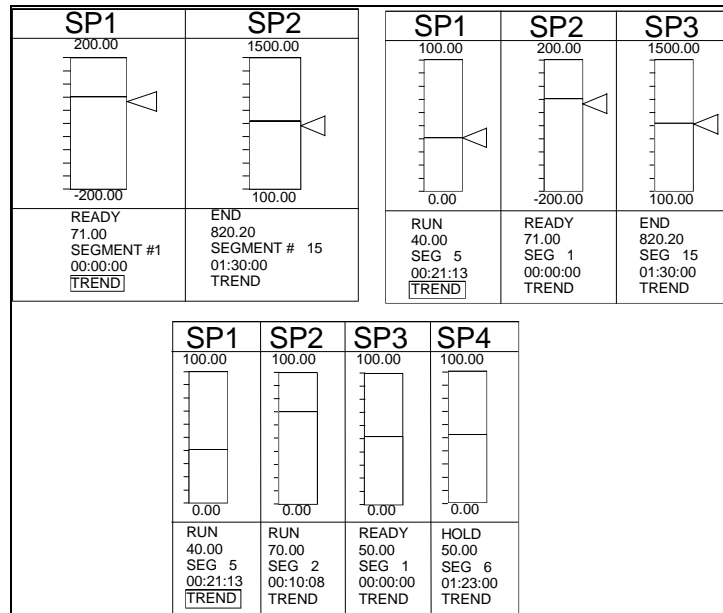


Figure 6-1 Setpoint Profile Summary Displays

### Interacting with Setpoint Trend Display

When a Setpoint Trend display is shown (Figure 6-2), press the Tab key to display options for controlling the profilers execution. See Section 5.5 for details on these options.

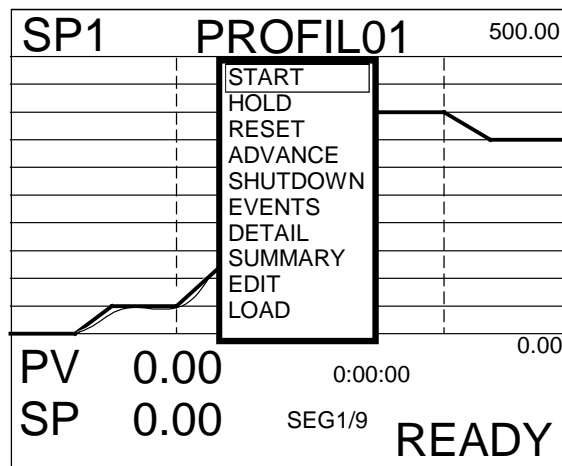
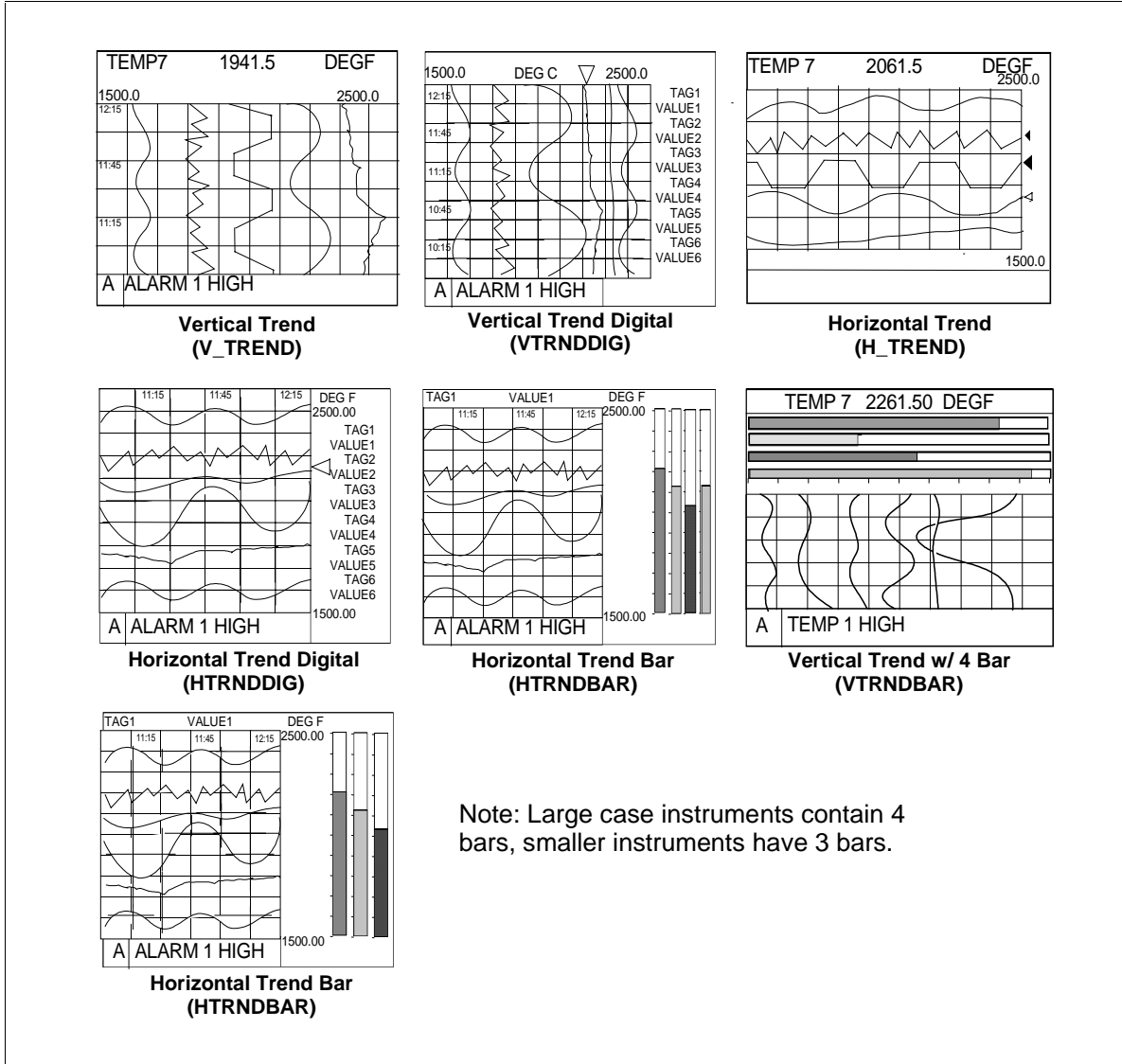


Figure 6-2 Setpoint Trend Display With Menu

Interacting with Live or Replay Trends

With a live vertical or horizontal trend is displayed (Figure 6-3), press Tab key to access the Point/Detail menu. When replaying (stored) trends this menu is always displayed. From this menu you can press the Tab key again to advance the scoreboard at the top of the display to the next point in the trend. Also, you can press the Up Arrow or Down Arrow buttons to scroll the trend forward or backward in time.



Note: Large case instruments contain 4 bars, smaller instruments have 3 bars.

Figure 6-3 Horizontal and Vertical Trend Displays

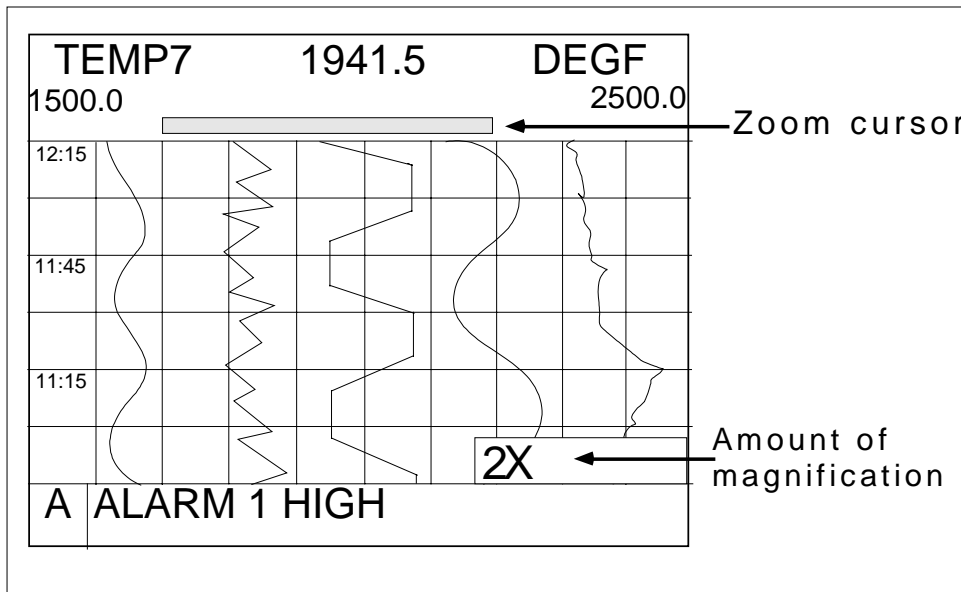
**Table 6-2 Point/Detail Menu Prompts**

Prompt	Definition
SCROLL	<p>Press the Up Arrow or Down Arrow buttons to scroll the trend forward or backward in time. Press Tab key to change to the next point on a multi-point trend.</p> <p>Press the Menu button to restore the Point/Detail menu. The trend display will remain at the time determined by the SCROLL.</p> <p>Press the Display button to restore the original primary display and cancel the SCROLL.</p>
SET HOLD, REL HOLD	<p>Causes one point to remain displayed in the scoreboard. Available for live trend only.</p> <p>Before selecting SET HOLD, press Point/Detail to change the scoreboard to the desired point. Select SET HOLD and press Enter. An "H" appears in the lower right display. The HOLD will remain in effect until deliberately removed with REL HOLD.</p> <p>To HOLD a different point, press the Tab key until the desired point is shown, then press the Display button.</p> <p>To release the HOLD, select REL HOLD.</p>
DETAIL	<p>Use the Up Arrow and Down Arrow buttons to move the line cursor forward or backward in time. The value of the displayed point will change to its value at the new time.</p> <p>If desired, press Tab to change to the next point on a multi-point trend.</p> <p>Press the Menu button to restore the Point/Detail menu. The trend display will remain at the chosen point.</p> <p>Press the Display button to restore the primary display and cancel DETAIL feature.</p>
FIND	<p>Lets you display the trend from a certain time. A list of times will appear on the display, as shown. FIRST is the oldest time available in the trend. LAST is the most recent time available.</p> <pre data-bbox="428 1087 873 1192">FIRST: JAN    1    1999  12:00 LAST:  JAN    5    1999  13:00 FIND:  JAN    1    1999  12:00</pre> <p>Select month, day, year, hour and minute. To cancel the search, press Display, Menu, Display1 or Display2 buttons.</p> <p>When the data has been found, the selected time/date will appear in the center of the trend area. The Point/Detail menu will also appear.</p>
ZOOM	<p>Lets you magnify (zoom) the displayed scale</p> <p>Press the Up Arrow and Down Arrow buttons to select the amount of magnification, shown in the lower right corner of the display. Note that the size of the Zoom cursor changes accordingly. See Figure 6-4.</p> <p>OFF – uses point's trend display limits (turns Zoom off)</p> <p>2X – uses half of point's trend display limits</p> <p>4X – uses one fourth of point's trend display limits</p> <p>FULL – uses point's programmed limits (not its trend display limits)</p> <p>Press the Tab key to select the point/trace to be zoomed (magnified).</p> <p>Press Enter to display the magnified trend. The Point/Detail menu is displayed to allow further analysis.</p> <p>Press the Display button to restore the primary display with the ZOOM limits. A "Z" appears in the lower right of the display.</p>

continued

**Table 6-2 Point/Detail Menu Prompts (continued)**

Prompt	Definition
TIMEBASE	<p>Lets you change the timebase of the trend. Choices are:</p> <p>NORMAL – use the trend’s normal timebase.</p> <p>ALTERN (Alternate) – use the trend’s alternate timebase.</p> <p>Move the cursor box to the desired timebase and press Enter. The trend will be redisplayed in the new timebase. An arrow points to the current timebase. Timebases are specified in the program mode. Available for live trends only.</p> <p>If a storage trend’s CHANGE WITH KEY is set to YES, then changing the timebase will also change the storage rate of the storage trend. That is, if the live Trend1 is displayed in NORMAL timebase, then the storage Trend1 will be stored at the LOW rate. If the live Trend1 is displayed in the ALTERN timebase, then the storage Trend1 will be stored at the HIGH rate. Trend2 behaves the same way.</p>
NEW FILE	<p>Select to see the Replay From Disk menu, from which you may select another stored file for replay. Available for replay trends only.</p>

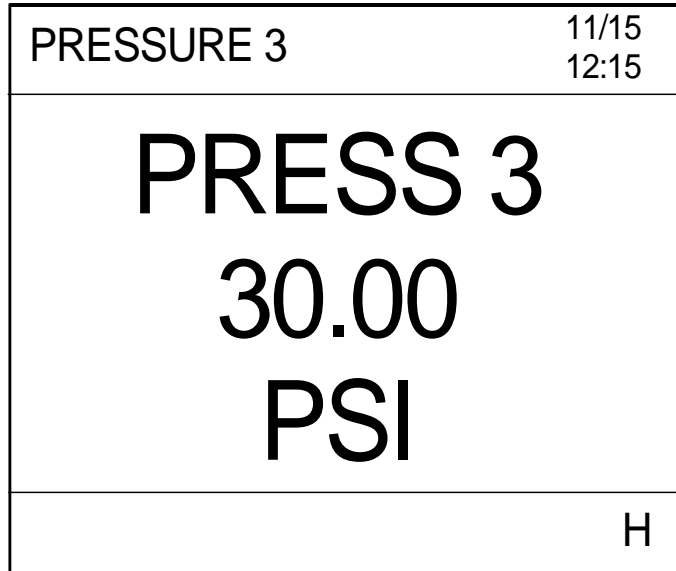


**Figure 6-4 Vertical Trend at 2X Zoom**



**Interacting with Panel Display (VPR 100/VRX100)**

To stop the rotation of the panel display on a single point, follow the procedure in Table 6-3.



**Figure 6-5 Panel Display**

**Table 6-3 Stop Panel Display Rotation Procedure**

Step	Action	Result
1	Press Tab key	Displays menu item SET HOLD at the lower right hand corner of the display.
2	Press Tab key	Displays the desired point.
3	Press Enter	Holds display on desired point. An "H" appears in the lower right of the display.

To resumes rotation through all points, follow the procedure in Table 6-4.

**Table 6-4 Resume Panel Display Rotation Procedure**

Step	Action	Result
1	Press Tab key	Displays menu item REL HOLD at the lower right hand corner of the display.
2	Press Enter	The "H" disappears and rotation resumes.

**Interacting with 4-Panel Display (VRX150)**

To stop the rotation of the 4-panel display on any 4 consecutive points, follow the procedure in Table 6-5.

PRESS 3 30.00 PSI	ZONE1 205.00 DEGF
TEMP2 134.4 DEGC	ZONE2 456.2 DEGF

**Figure 6-6 Four-Panel Display**

**Table 6-5 Stop 4-Panel Display Rotation Procedure**

Step	Action	Result
1	Press Tab key	Displays menu item SET HOLD at the lower right hand corner of the display.
2	Press Tab key	Each press advances through the points one at a time. After one press: Displays points 2-5. After two presses: Displays points 3-6. Etc.
3	Press Enter	Holds display on desired points. An "H" appears in the lower right of the display.

To resumes rotation through all points, follow the procedure in.

**Table 6-6 Resume 4-Panel Display Rotation Procedure**

Step	Action	Result
1	Press Tab key	Displays menu item REL HOLD at the lower right hand corner of the display.
2	Press Enter	The "H" disappears and rotation resumes.

Interacting with Loop Displays

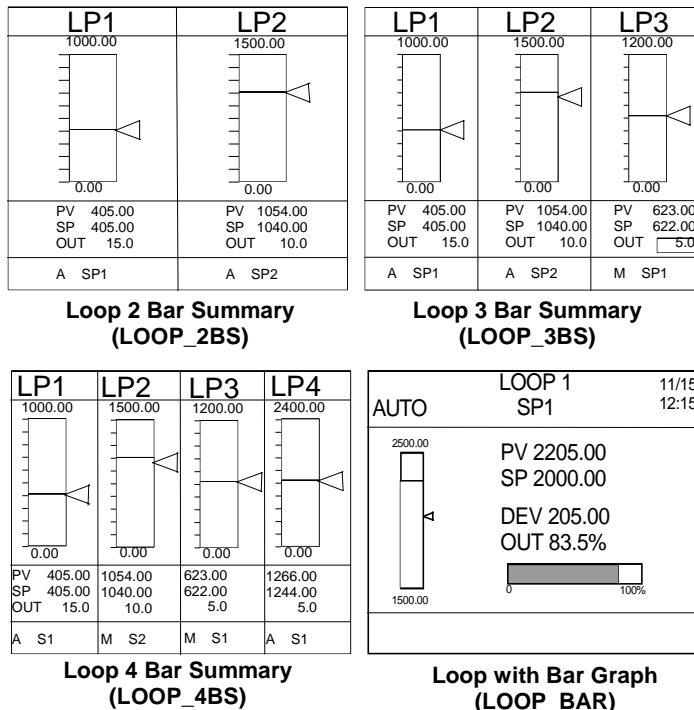


Figure 6-7 Loop Displays

When the Loop w/Bar Graph, Loop 2 Bar, Loop 3 Bar, or Loop 4 Bar display is shown you can:

- select Auto or Manual control mode for the loop,
- change loop output,
- change the setpoint value,
- switch to the Loop Tuning display for Setpoint 1/.Setpoint 2 toggle (for tuning parameters and pretuning).

Detailed instructions for performing these interactions are described in. Table 6-7.

Table 6-7 Interacting With Loop Displays

To perform this action	Do these steps
Move the cursor box to another area of the display	Press the Tab key to move the cursor to the Loop Tag at the top of the display, then to the setpoint value, then to the loop output value (if loop is in Manual mode).
Toggle the loop between Auto and Manual modes	Press Auto/Manual button. To use the Auto/Manual button all of the following conditions must be met. 1. Loop must be in Local mode, which means FORCE REMOTE MAN discrete parameter must be OFF. 2. DISCR VS KEY SEL discrete parameter must be OFF. 3. If security is active for AUTO/MAN changes, the security code must be entered first. For a description of the loop parameters FORCE REMOTE MAN and DISCR VS KEY SEL, see Table 4-10.

continued

**Table 6-7 Interacting With Loop Displays (continued)**

To perform this action	Do these steps
Lower or raise the loop output (displayed as %).	Press Tab key to move cursor to loop output. To change the output, the loop must be in manual mode (initiated by front panel key or by external discrete signal)— <b>not</b> in Remote Manual mode.
Increase or decrease Setpoint value	<p>Press Tab key until cursor is on the setpoint value. Press Up Arrow and Down Arrow to adjust value. Only numerically assigned setpoint values can be changed online; Setpoint #2 cannot be changed if it is acting as a remote setpoint (e.g. running a profile).</p> <p>You can also change the setpoint value by accessing the Tune Loop menu as described in the next row.</p>
Access the loop tuning parameters	Press Tab key until the cursor is on the loop tag at the top of the display. Press Enter to access the Tune Loop menu for that loop. Adjust desired parameters. To return to the loop display, press Menu. See Section 7.7 Tune Loop.

**Interacting with Alarm Summary**

PAGE 4	<b>ALARM SUMMARY</b>		14:25
PROCESS 1	TEMP 7	CURR=1234.56	HIGH 04/12/97
PROCESS 1	TEMP 8	CURR=2345.54	LOW 04/12/97
PROCESS 3	TEMP 9	CURR=1234.56	HRATE 04/12/97
A	D	DISK FULL	

**Figure 6-8 Alarm Summary Display**

Refer to section 7.4 Access Summaries for details.

## 6.3 Display Messages and Symbols

### Overview

Messages and symbols will appear in different areas of the display to inform the operator of a variety of conditions. The area across the bottom of the display (Figure 6-9) is reserved for messages that require the operator to take action. They include Active Alarm Symbols, Diagnostic Messages, and Data Storage Messages.

### Location

The Alarm and Diagnostic messages consist of a symbol on the left side of the display and a text message next to it on the right. The Data Storage message has no symbol and includes only the text portion.

### Multiple messages

If multiple messages are present simultaneously, they will be arranged in a “cascaded” or “shingled” arrangement, so that underlying symbols will be visible (data storage on top, diagnostics in the middle, alarms on bottom).

### Example of primary display

Figure 6-9 shows an example of a primary display.

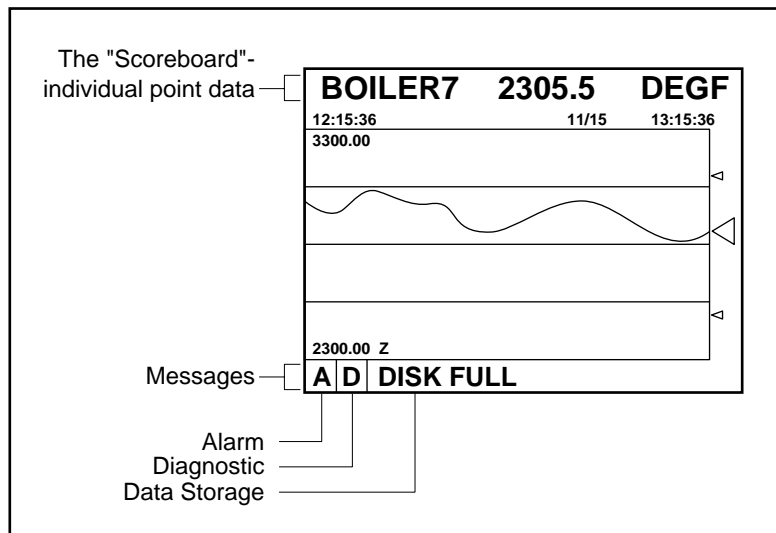


Figure 6-9 Example of Primary Display

Description of Messages and Symbols




Table 6-8 Messages and Symbols at Bottom of Display

Message/Symbol	Color	Description
<b>A</b> followed by text description of alarm	Red	An active alarm exists. Flashes while unacknowledged. When the operator acknowledges the alarm, the flashing will stop. The symbol and text will remain until the alarm has cleared.
<b>D</b> followed by text description of diagnostic	Blue	A diagnostic error has been detected. Flashes while unacknowledged. The symbol and text will remain until the operator acknowledges or deletes the diagnostic in the online Access Summaries menu.
<b>Data Storage Messages</b>	<b>Color</b>	<b>Description (shown low to high priority)</b>
UPDATING DISK	Yellow	Instrument is flushing all buffered data to the disk.
CHECKING DISK	Yellow	Whenever the front panel has been opened and closed, the instrument checks that a properly formatted disk is installed and ready to receive data.
INITIALIZING	Yellow	Initialization is in progress.
DS INIT FAILED	Yellow	Initialization failed. Possible reasons: disk has not been formatted, is write-protected, or is defective.
STORAGE FULL	Yellow	Less than 5 minutes of space remains in the internal buffer. Data is accumulating in the internal buffer (temporary storage) because it is unable to store the data on the floppy disk. Possible reasons include: <ul style="list-style-type: none"> <li>• Disk is full and storage is programmed as non-rollover</li> <li>• There is no disk in the drive</li> <li>• The disk is write-protected.</li> <li>• The operator is in the process of retrieving stored data from the disk</li> <li>• The disk is “not current” (see DSK NOT CURRENT below)</li> <li>• The front bezel is open.</li> </ul> The message will disappear when the condition is corrected, or if data storage is disabled (turned off).
DISK FULL	Yellow	No more space is available on one or more of the files on the floppy disk for storage of data as programmed. This message will appear only if at least one partition on the disk is programmed for non-rollover operation. The message will disappear when a new disk is initialized, or if data storage is disabled (turned off).
DISK WARNING	Yellow	Floppy disk is not full but available space on one or more disk files has reached the programmed warning limit. The message will disappear when a new disk is initialized, or if data storage is disabled (turned off).
BEZEL OPEN	Yellow	Instrument front panel is open or is not closed securely.
DISK ERROR	Yellow	The instrument is attempting to store data but the disk is either not properly formatted or is faulty. The message disappears when the disk is formatted or replaced, or if data storage is disabled (turned off).
DSK NOT CURRENT	Yellow	When a disk is initialized the instrument marks it as the “current” disk. The instrument will only store data to the “current” disk. If any other disk is placed in the drive this message will appear. The message will disappear when the “current” disk is inserted or a new disk is initialized.
WRITE-PROTECTED	Yellow	The disk in the drive has its write-protected tab set to the protect position.
DISK MISSING	Yellow	Data storage is enabled, but no disk is installed in the disk drive.

**Table 6-8 Messages and Symbols at Bottom of Display** (continued)

Message/Symbol	Color	Description
GENERAL ERROR	Yellow	This message will appear if the instrument encounters any error not mentioned above.
<b>S</b>	Yellow	Located in bottom right of display. Indicates storage is active data is being collected on disk or in the instrument's internal buffer.
<b>Z</b>	White	Located in bottom right of display. The display's upper and lower limits are zoomed on a smaller range. Disappears when Zoom is turned off.
<b>H</b>	White	Located in bottom right of display. Indicates the display is held on a single data point and is not rotating through all data points. Disappears when Point Hold is removed.

**Table 6-9 Messages and Symbols Elsewhere on Display**

Message/Symbol	Color	Description
REVIEW or REPLAY	White	Trend Replay/Review. Adjacent to detailed point information (scoreboard) on the screen. Indicates that the trend on the display is from historical data and does not represent the current state of the process. REVIEW means that the data for the trend are from current memory (RAM). REPLAY means that the data are retrieved from floppy disk (data storage).
<b>*</b>	White	Analog Input Value Adjust. Located to the right of the data point value. This message appears only on the AI Value Adjust display. It indicates that a bias has been manually applied to the value of the particular data point. The symbol will disappear when the value is set to OFF.
	Red	Low Alarm Setpoint. Located above vertical trends, right of horizontal trends, along side of bar graph. These symbols appear automatically if a displayed point is the input to one or more Alarm function blocks. The first 4 low type alarm blocks using the displayed points are represented by these symbols.
 or 	Red	High Alarm Setpoint. Located above vertical trends, right of horizontal trends, or along side of bar graph. These symbols appear automatically if a displayed point is the input to one or more Alarm function blocks. The first 4 high type alarm blocks using the displayed points are represented by these symbols.
Flashing between ***** and value	Same as data point	Bad Input Values. Appears in place of the value on all displays. Value is outside the programmed limits. Caused by an upstream AI failure (AI is open circuit and failsafe or is type linear and outside its programmed range by 10% or more).
Flashing between value and blank	Same as data point	Questionable Input Values. Appears in place of the value on all displays. Value is clamped at its limit.
Flashing between value and blank	Same as data point	Output Limits of Totalizer or Interval Timer Exceeded. Appears in place of the value on all displays. Interval Timer's or Totalizer's value is outside its output limits. Value is not clamped.





## 7. Online Operation Using Menus

### 7.1 Overview

Online operation involves interacting with displays and with menus. This section describes how to interact with the online menus.

The Online Menu is accessed by pressing the Display button, then the Menu button. Or, you can choose SET MODE from any menu to change the mode.

#### ATTENTION

When switching to Online mode from Program or Maintenance modes by pressing the Display button, sometimes incorrect data is displayed for a few seconds before the correct online display is shown. You can avoid this distraction by selecting ONLINE from the SET MODE menu instead.

The top level of the menu structure is shown in Table 7-1. Your unit may have a reduced menu if options are not present or if features have been disabled through programming selections.

**Table 7-1 Online Mode Menu**

Menu as displayed	Function
SET MODE	Change instrument's operating mode
DATA STORAGE	Set up and operate data storage
ACCESS SUMMARIES	Display status summaries
DATA ENTRY	Adjust function values and states
SETPOINT PROFILES	Edit profile parameters. Store and load programs.
TUNE LOOP	Enter loop tuning values. Pretune loop.
REVIEW PROGRAMMING	View all programming (read only)

## 7.2 Set Mode

Select this item to change the operating mode of the instrument to Program or Maintenance. These operating modes are discussed in Sections 4, 7, and 8.

## 7.3 Data Storage

### Overview

Data Storage lets you store trend data, unit data, alarms, events, and diagnostics for later review onscreen or on a PC with SDA software. Setup and configuration of Data Storage is described in Section 4.26; online operation is described here.

### Typical online data storage tasks

1. Removing, installing, and labeling disks.
2. Initializing new disk using the current Data Storage setup schedules.
3. Checking current storage setup.
4. Starting and stopping storage (3 methods):
  - a) Start/stop all storage via ENABLE STORAGE menu.
  - b) Start/stop a particular storage file's storage via its external enable discrete.
  - c) Start/stop all storage batches via BATCH STATE menu item or via BATCH CONTROL discrete.
5. Checking storage status with DATA STORAGE STATUS display.
6. Replaying data stored on disk.
7. Reading data storage messages.

### Installing a disk

The disk must be DOS-formatted. Formatting may be done at a PC or in the instrument with DATA STORAGE menu item FORMAT DISK (1.44MB disk only). Maintaining a stock of several formatted disks is recommended to minimize maintenance time on the instrument. For 120MB or Zip disks it is recommended you preinitialize them using DSU. See Data Storage in section 4.26 for more information.

Disks are inserted and removed from the front panel as described in Table 7-2.

**Table 7-2 Floppy Disk Insertion/Removal Procedure**

Step	Action
1	Press the button on the underside of the bezel to release the latch. The latch will release easily if you press the bottom of the bezel back towards the panel to compress its gasket as you press the button.
2	Pull the bottom of the bezel outwards slightly away from the panel and then lift it gently up to fully open it.
3	Insert the disk into the slot until it catches in place.
4	To remove the disk, press the rectangular button next to the slot. Be sure to label the contents of each disk.
5	To close the bezel, lower it until it is almost closed. Engage the top edge of the bezel first and then swing the bottom inward. Press the bottom in firmly until the latch clicks into place. Be careful to fully close the bezel, or the unit will not function normally.

### How data is stored

To provide continuity of storage when the disk is removed, the data storage feature buffers data internally for a period of time based on the storage rate and amount of storage data. Since storage files and configuration files may not be stored on the same disk, you can swap the storage disk with a configuration disk for up to the buffered data time period while loading configurations without losing storage data. See Data Storage in section 4.26 for more information on buffered data. When the storage disk is re-installed, or when another disk is initialized using the current schedules, the buffered data will be transferred to the disk.

### Initializing a disk

Initialization creates separate areas on the disk for each type of data to be stored. Data types that can be stored are up to 3 Trends, Alarms, Events, Diagnostics, and Unit Data. You can initialize a disk using the current storage schedule or using a new storage schedule.

When data storage is active, the instrument determines the status of the disk. Status can be one of the following possibilities.

**Table 7-3 Disk Status**

Disk status	Result
The "current" disk was inserted back into the drive.	The instrument will resume storage to this disk automatically.
Some other disk was inserted. That is, disk is blank, contains old data files or contains configuration files.	In this case, a DISK NOT CURRENT message is displayed and data is stored in a buffer, not on the disk.

### Initializing a disk using the same storage setup

For 120MB or Zip disks it is recommended you preinitialize the disk using DSU. See Data Storage in section 4.26 for more information.

To continue storing the same data storage schedule on this disk, select the online DATA STORAGE menu, select INITIALIZE DISK, then select USE CURRENT SCHEDULES. The instrument will display a prompt asking for a yes or no response to initialize the disk. **Initializing will destroy all existing information on a 1.44MB disk.** With this prompt you can remove a disk inserted by mistake, or deliberately re-use an old disk containing useless information. If you answer YES, the current schedule will be established on the new disk, buffered data will be stored to the disk, and if any storage files are in batch mode, the batch counter will be reset to zero (0).

### Initializing a disk using a new storage setup

For 120MB or Zip disks it is recommended to preinitialize the disk using DSU. See Data Storage in section 4.26 for more information.

If you change any part of data storage schedule (as described in Section 4.26) and you want the changed (new) schedule's data to be stored, select the online DATA STORAGE menu, select INITIALIZE DISK, then select USE NEW SCHEDULES. All data that was buffered since the previous disk was removed is lost. See Data Storage in Section 4.26. If you change the schedule but initialize using the current schedule, the changed (new) schedule is not stored.

### Initialization errors

If an initialization error occurs, one of the following messages may appear.

Error message	Meaning
BEZEL OPEN	Disk use is not permitted while the front panel bezel is open. The bezel must be closed and latched.
WRITE-PROTECTED	The write protect tab is set (open) on the floppy disk. The tab must be closed to permit data storage.
DISK ERRORS	The disk installed in the drive is faulty or is not a DOS formatted 1.44 Mb disk. It must be formatted before it can be initialized. Formatting can be performed on an IBM compatible PC or with the FORMAT DISK command in the Maintenance menu.
DISK IS MISSING	No disk is installed in the drive.

### Checking current storage setup

To see what is being stored and when, select DATA STORAGE, then select REVIEW CURRENT SCHEDULES. See Section 4.26 for description of schedules.

**Starting and stopping storage**

Data Storage can be started and stopped three ways. At the highest level, the ENABLE STORAGE menu item enables or disables all data storage. At the next highest level, EXTERNAL ENABLE enables or disables storage for each file type (Trends #1-3, Alarms, Events, Diagnostics, Unit Data). At the lowest level, storage for each file type is started and stopped with one of two controls: a menu item BATCH STATE or a discrete parameter BATCH CONTROL.

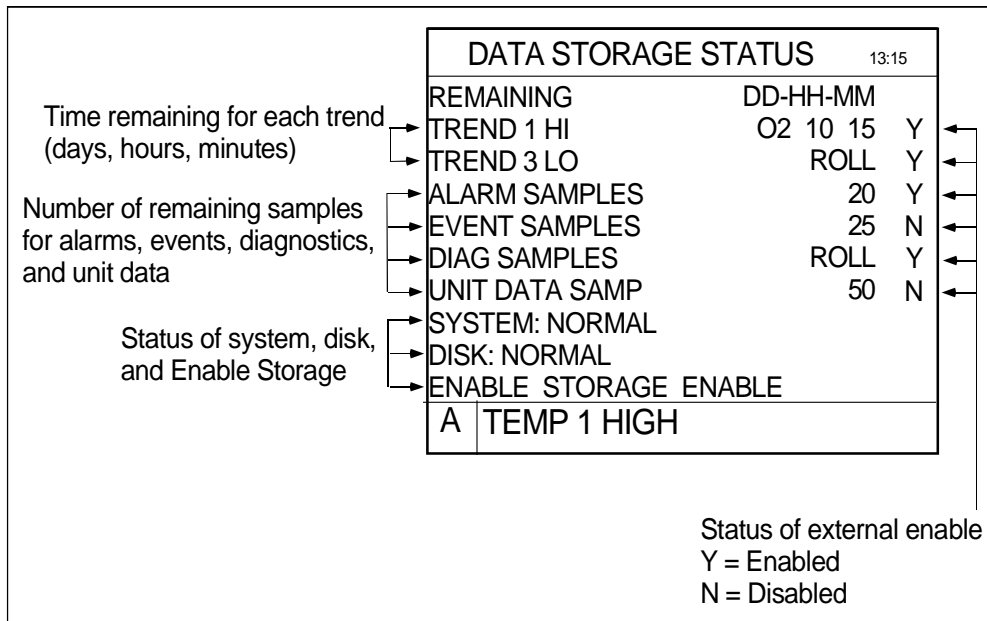
Table 7-4 describes each method of starting and stopping storage.

**Table 7-4 Storage Start/Stop Controls**

Prompt	Comments
ENABLE STORAGE	Acts as a master enable/disable switch for all data storage. Select this item from the DATA STORAGE menu. Set to ENABLE to allow storage of the current schedule. <b>If this is set to DISABLE, online data storage cannot take place, even if storage for individual files is enabled with EXTERNAL ENABLE.</b>
EXTERNAL ENABLE	Acts as a enable (high)/disable (low) switch for each storage file type (trends, alarms, events, diagnostics, unit data). Any storage file whose external enable is configured with a discrete will start and stop according to the state of that discrete. This works independently of batch storage.
BATCH STATE	Acts as a start/stop switch for each storage file type. The ENABLE STORAGE and EXTERNAL ENABLE both must be enabled for BATCH STATE to function.  Accessed under DATA STORAGE menu. If batch storage mode is configured for any storage file and if BATCH CONTROL has not been configured with a discrete, then you can manually start/stop the batches using this selection. The instrument will automatically assign a number internally to identify the batch for storage. For example, data stored between the first start and stop is marked as Batch #1. When the next batch starts, the instrument will increment the batch number. These numbers identify the batches for later retrieval.
BATCH CONTROL	Accessed under SET UP NEW SCHEDULES. If this item is configured with a discrete, it will start and stop storage for all storage files configured with batch storage mode. The ENABLE STORAGE and EXTERNAL ENABLE both must be enabled for BATCH CONTROL to function. The instrument will automatically assign a number internally to identify the batch for storage. For example, data stored between the first start and stop is marked as Batch #1. When the next batch starts, the instrument will increment the batch number. These numbers identify the batches for later retrieval.
BATCH NUMBER	Accessed under DATA STORAGE. Shows the number (1-255) of the active batch. The batch number is assigned automatically by the instrument when the batch is started by either method (BATCH CONTROL or BATCH STATE).

**Checking Data Storage Status**

The Data Storage Status display is accessed under Data Storage on the main online menu. It is also accessed by pressing any display button, if the button has this display assigned to it. See Figure 7-1.



**Figure 7-1 Data Storage Status Display**

## Replaying stored data

Data stored on floppy disks can be retrieved and displayed online at any time, whether data storage is active or not. All data is stored as individual files and is retrieved by filename. To retrieve a file from disk, follow the procedure in Table 7-5.

**Table 7-5 Data Storage Replay Procedure**

Step	Action
1	Insert the disk containing the desired file into the instrument.
2	Select DATA STORAGE and then REPLAY FROM DISK. A list of filenames of all the files on the disk will appear. The filename extension identifies the type of data in the file. Note: Events can only be replayed with SDA data analysis software.  .LNT Trend  .LNA Alarms  .LNE Events  .LND Diagnostics  .LNU Unit Data
3	Select a start time within the first and last times. Data replay will begin at this time. For trends, select horizontal or vertical replay format and screen size (timebase).
4	Select Replay to view the data.

### ATTENTION

If you are replaying data from a “non-current disk,” keep in mind that the instrument will continue acquiring data and holding it temporarily in its active memory (RAM) until you insert a proper disk for storage. If you spend too much time replaying data, the instrument could run out of active memory space. If this occurs, a storage full warning message will be displayed. See Table 6-8 for an explanation of the various warning messages.

## Examining replay data

For details on examining replay trend data, see Section 6.2, Interacting With Primary Displays. To examine replayed alarms, events, and diagnostics, use the Up Arrow or Down Arrow keys.

## Reading Data Storage Messages

See Data Storage Messages in Table 6-8 for message descriptions.

## 7.4 Access Summaries

Summaries are available for all points, alarms and diagnostics in the instrument.

### Display alarm summary

Alarms are set up as part of the instrument configuration procedure (Section 4.13). Up to 16 alarms can be configured.

An alarm can be assigned to any analog data point (Analog Input, Analog Output, or Calculated Value) and can be one of these types.

Alarm type	Function
HIGH	Alarm when input value $\geq$ setpoint value.
LOW	Alarm when input value $\leq$ setpoint value.
DEV (Deviation)	Alarm when input value deviates above or below compare point value by an amount $\geq$ setpoint value.
LDEV	Low Deviation. Alarm when input value deviates below compare point value by an amount $\geq$ setpoint value.
HDEV	High Deviation. Alarm when input value deviates above compare point value by an amount $\geq$ setpoint value.
HRATE (High Rate)	Alarm when input value increases at rate $\geq$ setpoint value, in units per minute. Negative rate setpoints are processed as positive values. May take up to 30 seconds to activate.
LRATE (Low Rate)	Alarm when input value decreases at rate $\geq$ setpoint value, in units per minute. Negative rate setpoints are processed as positive values. May take up to 30 seconds to activate.

An alarm programmed with delay will not activate before its delay time. An alarm programmed with hysteresis will clear after its hysteresis delay.

The alarm will remain active as long as the conditions causing it remain. When the conditions no longer exist, the alarm will be “cleared” automatically. “Clear” means that the indicators for the particular alarm on all displays will be removed and the alarm will be removed from the Alarm Summary list.



### What happens during an alarm

- A flashing red alarm indicator appears on the bottom of all screens. (The alarm must be acknowledged to stop the flashing.) On displays where the alarm point appears, the value is red and a red indicator appears.
- The alarm is entered into the active alarm summary which can be viewed at any time. The alarm summary contains the point identification, a description of the alarm, the sense (high, low rate, etc.), the time of occurrence and the current value of the point.
- When the alarm clears, the time of occurrence and the time of clearing will both be entered into the Alarm History, which is an ongoing record of the occurrence and clearing of all alarms.
- If so configured, the alarm occurrence will also be logged on a summary list stored on floppy disk (see Data Storage, section 4.26).
- If so configured, the alarm triggers a discrete output relay. The relay returns to normal state only when the alarm is cleared.

### Acknowledging alarms

When an alarm occurs, it must be acknowledged by the operator to stop its indicator from flashing. Acknowledging an alarm **does not** clear the alarm. See Table 7-6 for procedure.

**Table 7-6 Alarm Acknowledgment Procedure**

Step	Action
1	Select ACCESS SUMMARIES from online menu.
2	Select DISPLAY ALARM SUMMARY to display a list of active alarms. Up to 4 pages (12 alarms) can be listed. Unacknowledged alarms will be flashing.  Display Alarm Summary can also be accessed by pressing the Display button, if the Alarm Summary display was assigned to that button. See Section 4.18.
3	Press the Up Arrow or Down Arrow button and a cursor will appear on the display. Use the Up Arrow or Down Arrow button to position the cursor on a flashing alarm and press Enter to acknowledge the alarm. The flashing will stop and the cursor will disappear.  If you do not press any button for a period of 5 seconds, the cursor will disappear. This is a safety feature, because while the cursor is visible on the display, the display is temporarily disabled and a new alarm will not be shown.
4	If there are more flashing alarms, press the Up Arrow and Down Arrow buttons to restore the cursor.

### Display Alarm History

The Alarm History display is a multi-page display which lists information on cleared alarms. The most recent 25 cleared alarms will be shown, with the oldest being dropped from the list when a new alarm clears and is logged in.

The Alarm History includes the descriptor and tag identifiers of the alarm, the type (high, low, high rate, etc.), the setpoint value at the time the alarm occurred and the date and times of the occurrence and clearing of the alarm (designated as IN and OUT times, respectively).

Use the Up Arrow and Down Arrow buttons to view the various pages of the display, as desired.

## Display Diagnostics

A Diagnostic is a displayed error message that indicates a serious error or failure has occurred. See Section 9.5 for diagnostic descriptions and possible causes.

### What happens during a diagnostic

- A flashing blue diagnostic indicator will appear on the bottom of the screen.
- The diagnostic message will be entered into the diagnostic summary which can be viewed at any time. The summary contains each message and the date and time of occurrence.
- If Data Storage is set up accordingly, the diagnostic occurrence will also be logged on a summary list stored on floppy disk.
- The diagnostic summary can contain a maximum of 50 messages with the newest shown at the top of the list. As new diagnostics occur beyond 50, the oldest will be dropped from the list. Diagnostic messages are not automatically removed from the summary if the error condition is corrected. The list must be deleted from the screen periodically by the operator as described under Delete All Diagnostics.

### Acknowledging Diagnostic Messages

When a diagnostic occurs, it must be acknowledged by the operator to stop its indicator from flashing. See Table 7-7.

Acknowledging a diagnostic only stops its indicator from flashing; it does not correct the cause of the diagnostic. You are not required to acknowledge a diagnostic. The flashing can also be stopped if all diagnostics are erased, using the DELETE ALL DIAGNOSTICS menu selection.

**Table 7-7 Diagnostic Acknowledgment Procedure**

Step	Action
1	Select ACCESS SUMMARIES from the main online menu.
2	Select DISPLAY DIAGNOSTICS to display a list of diagnostics. Unacknowledged diagnostics will be flashing.
3	Press the Up Arrow or Down Arrow button and a cursor will appear on the display. Use the Up Arrow or Down Arrow button to position the cursor on a flashing diagnostic and press Enter to acknowledge the diagnostic. The flashing will stop and the cursor will disappear.  If you do not press any button for a period of 5 seconds, the cursor will disappear. This is a safety feature, because while the cursor is visible on the display, the display is temporarily disabled and a new diagnostic will not be shown.
4	If there are more flashing diagnostics, press the Up Arrow and Down Arrow buttons to restore the cursor.

### Display All Analogs

Displays current value of all analog points in the instrument. These include all analog I/O, loops, calculated values, totalizers and system parameters. Only those points that have been programmed will be displayed.

### Display All Discretets

Displays current status of all discrete points in the instrument. These include all discrete I/O, alarms, loops, calculated values, totalizers and system parameters. Only those points that have been programmed will be displayed.

**Delete All Diagnostics**

A diagnostic is not automatically cleared from the summary when the error has been found and corrected. Table 7-8 gives the procedure for deleting the diagnostics.

**Table 7-8 Delete All Diagnostics Procedure**

<b>Step</b>	<b>Action</b>
1	Select ACCESS SUMMARIES from the Main On-Line Menu.
2	Select DELETE ALL DIAGNOSTICS to delete all diagnostics from the summary.
3	Press Menu or Display buttons to exit the menu.

**Product Information**

Select this item to display the logo screen, which includes the product identification, software version number, part number of the PROM, and serial number.

## 7.5 Data Entry

Data Entry lets you enter or revise data online. Choices available depend on installed options and enabled features (see “Enable Features” in Section 4.19).

### Edit Alarm Setpoints

Select this item to display a list of alarms and their setpoints. If the setpoint is a numeric value, it can be changed on this display using the Up Arrow and Down Arrow buttons. If it is programmed as a parameter, it cannot be changed here.

### Edit Constants

Select this item to display or change a list of all constants in the instrument. To change a value, use the Up Arrow and Down Arrow buttons.

### Force Discrete Inputs/Outputs

Select either of these items to display or force the status of any discrete.

The STATE indicates ON or OFF. FORCE/RELEASE indicates if the discrete is forced or released (unforced). To force a discrete, select FORCE ON or FORCE OFF. To release a forced discrete, select RELEASE. Adjust with Up Arrow and Down Arrow. Press Enter to enter the changes. Press Menu to leave the menu.

### Adjust Analog Inputs

Select this item to display a list of all the analog inputs presently configured. Analog Input Adjust may be applied or removed from any AI on the list. If the AI point has been configured with a pyrometer range, the Input Adjust is applied as a multiplier (equal to the newly entered value divided by the actual measured value at the time that the adjustment is entered). In this case, the Value Adjust is referred to as an “emissivity” adjustment. If the AI point has been configured with any other range, the value adjust is applied as a bias (equal to the newly entered value minus the actual measured value at the time that the adjustment is entered).

All points on the display which are currently adjusted will have a Value Adjust Indicator (\*) beside the value.

To adjust a value, select the desired AI and press Enter. Use the Up Arrow, Down Arrow and Enter buttons to change the value on the display. The value can be changed to any value within the programmed limits of the AI.

To remove the value adjustment, set the value to OFF. The AI will display its current value and the indicator (\*) will be removed.

### Set Analog Outputs

This menu item will appear if the optional analog outputs are installed. It lets you adjust various analog output parameters.

Four output types are available: current output (CAT), voltage output (VAT), time proportion/duration adjusting (DAT) and Position Proportion (PP). Outputs 1 through 3 may be dedicated to CAT or VAT types. Outputs 4 and 5 may only be DAT types.

Prompt	Definition
FAILSAFE VALUE	Enter a value of 0 to 100% or an analog parameter for the initial output. This is the initial output on “cold start”. If the failsafe value is set to off, the output will go to 0.
IMPULSE TIME	For DAT outputs, use the Up Arrow, Down Arrow and Enter buttons to adjust the impulse time. Impulse time must be $\geq 1$ second. Impulse time is the cycle time for on and off cycling of the output. For example, an impulse time of 150 seconds will cause the output to be on for 75 seconds and off for 75 seconds when the input source is at 50.
SENSITIVITY	Applies to PP type AO only. This is a percentage value. This value should be set to the highest number which does not cause drive motor oscillation.
POS ALGORITHM	Applies to PP type AO only. The PP and Auto algorithms require a feedback analog input. The selection of Auto allows normal PP feedback positioning of a drive motor when the feedback input is good, and defaults to DIAT operation if the slidewire feedback input fails. Use of Auto requires that the loop type be DIAT. The PP algorithm can be used with all other PID loop types.

### Reset Totalizers

Select this item to display a list of all resettable Totalizers and their current values. If the Totalizer is non-resettable it will not appear. You may use this display to reset one Totalizer, or all at once. Note that some or all Totalizers may be configured to be non-resettable. Use the Up Arrow, Down Arrow and Enter buttons to select an item from the list. At the prompt “RESET”, press Enter to reset the Totalizer.

To reset all Totalizers, select the menu line “RESET ALL TOTALIZERS” and press Enter at the prompt. All resettable Totalizers will be reset. Only resettable totalizers are shown here.

## 7.6 Setpoint Profiles

For instructions on this menu, see Section 5.4 How to set up a profiler, Tables 5-4 and 5-5.

For instructions on common operator tasks with the Setpoint Profiler, see Section 5.5.

## 7.7 Tune Loop

This option lets you tune (change) various loop parameters online. These tunable parameters depend on the loop type in use and are described in Section 4.8, Program Control Loops. Also, the following menu choices are available.

**Table 7-9 Tune Loop Prompts**

Prompt	Range/Selections	Definition
<b>LOOP TYPE</b>	STD, ADV, SPLIT, ON OFF, CAS P, CAS S, RATIO, DIAT	STD: Standard ADV: Advanced SPLIT: Split Output ON OFF: On/Off CAS P: Cascade Primary CAS S: Cascade Secondary RATIO: Ratio DIAT: DIAT
<b>PV</b>	Number	Value of PV
<b>OUTPUT</b>	-100 to +100	Loop output %.
<b>SETPOINT SOURCE</b>	SP1 or SP2	Indicates which setpoint is being used by the loop. SP1 must be a number; SP2 may be a number or a value from a function block (remote setpoint).
<b>Bold items are read-only</b>		
<b>TOGGLE SETPOINT SOURCE</b>	SP1, SP2	Press Enter to change the Setpoint Source from SP1 to SP2 or vice versa.
<b>SETPOINT #1</b>	Number	Enter the new value of SP1.
<b>SETPOINT #2</b>	Number or parameter	Enter the new value of SP2. If SP2 is a remote setpoint you cannot change the value here.
<b>PROP. BAND #1</b>		See Gain #1.
<b>GAIN #1</b>	Enter a value of 0.1 to 200 for Gain, or 0.5 to 1000.0 for Proportional Band. Enter OFF to allow integral only control.  (Variable Gain1 or PB1 is available by programming a constant's Destination with GN or PB. See Program Constants, Section 4.16.)	Gain is the proportional gain entry for the control loop (The value entered here is the gain applied to the error signal to determine the loop output. For example, a 10% change in process variable (with respect to the input range) from a balanced condition will result in a 10% change in output, when a gain of 1.0 is used. Enter a starting value at initial configuration. The value may be altered Online for final loop tuning. If an indirect source is specified as in an adaptive gain configuration, the value can only be altered at the source.  Gain and Proportional Band are interchangeable values (Proportional Band = 100/Gain). For loops with dual tuning, Gain 1 is the gain for the first set of tuning parameters. Gain 2 is for the second set.

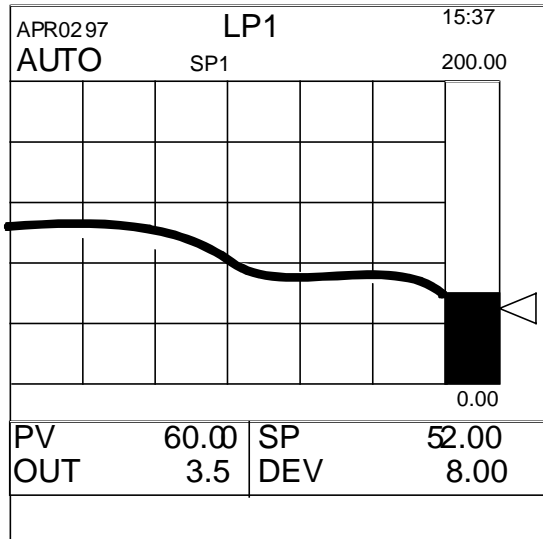
**Table 7-9 Tune Loop Prompts (continued)**

Prompt	Range/Selections	Definition
RESET #1	0.005-99.99 repeats/minute	<p>Determines the period of time for a repeat of the proportional gain output. Enter a starting value at initial configuration. The value may be altered Online for final loop tuning. For loops with dual tuning, Reset 1 is the time for the first set of tuning parameters. Reset 2 is for the second set. (Variable Reset1 is available by programming a constant's Destination with RS. See Program Constants, Section 4.16.)</p> <p>A value of OFF may be entered to allow proportional-only control. When turned off, the manual reset value determines the loop output at setpoint. Bumpless manual to automatic transfer is canceled when proportional only control is selected.</p>
RATE #1	0.02-10.00 minutes	<p>Modifies the loop output based on the rate of change of the process variable. The output is modified by a value that assumes the rate of change of the process variable will continue for the time period specified. Enter a starting value or OFF at the time of configuration. The value may be altered Online for final loop tuning. For loops with dual tuning, Rate 1 is the rate for the first set of tuning parameters. Rate 2 is for the second set. (Variable Rate1 is available by programming a constant's Destination with RT. Program Constants, Section 4.16.)</p>
PROP. BAND #2		See GAIN #1
RESET #2		See RESET #1
RATE #2		See RATE #1
MANUAL RESET	-100 to +100	<p>This feature functions only when OFF is configured for the loop's RESET parameter. Enter a value equal to the desired loop output when the process variable is at setpoint. This allows correction of output to account for load changes to bring the process variable up to setpoint.</p>
SUPPRESS OVERSHOOT	YES, NO	<p>This parameter set to YES limits overshoot of the Setpoint (SP) by the Process Variable (PV) after a disturbance in the process such as a load or SP change. Through fuzzy logic, the working SP of the control loop is dynamically modified by the control algorithm to reduce or eliminate overshoot.</p>
PRETUNE		<p>Pretune calculates optimum values for a loop's Proportional Band/Gain, Reset and Rate by analyzing the reaction of the loop to a "step change" in setpoint or output. After these new tuning values have been calculated you have the option of applying (installing) or not applying them to a preselected tune set of the loop. You can pretune a loop while another loop is pretuning.</p> <p>See Pretune Loop on page250.</p>
SET TIMEBASE	5 MIN, 15 MIN, 30 MIN, 1 HR, 2 HR, 4 HR	Enter the timebase for the time axis of the tuning trend display.



**Table 7-9 Tune Loop Prompts (continued)**

Prompt	Range/Selections	Definition
DISPLAY TUNING TREND		<p>Select this to display the actual tuning trend with PV and setpoint (Figure 7-2). Data collection for this trend display will continue as long as the display shows either the trend or the Loop Tuning Menu. Use this display to help find the optimal tuning parameters.</p> <p>Note: If you access this display through a loop display (by Tabbing to and selecting the loop tag name at the top of any loop display), the trend data is not buffered when you leave and return to this tuning trend display. Therefore, if you wish to adjust tuning parameters and then look at the trend to see the effects, it is recommended you select Tune Loop through the Online menu, not through a loop display.</p>



**Figure 7-2 Control Loop Tuning Display**

### Pretune Loop

Pretune calculates optimum values for a loop's Proportional Band/Gain, Reset and Rate by analyzing the reaction of the loop to a "step change" in setpoint or output. After these new tuning values have been calculated you have the option of applying (installing) or not applying them to a preselected tune set of the loop. You can pretune a loop while another loop is pretuning.

To use pretune, your process time constant must be at least 60 seconds. The *process time constant* is defined as the time needed for the PV to change by 63% of a step change in the setpoint. For example, if the setpoint changes instantaneously by 100 degrees, the time constant is the amount of time needed for the PV to change 63 degrees.

To pretune a loop, select PRETUNE from the TUNE LOOP online menu. Select a loop to tune. Pretune occurs in 4 stages as indicated by the status. Each status has its own menu. Table 7-10 shows the stages of pretune.

**Table 7-10 Stages Of Pretune**

Order	Status	Meaning
1	STOPPED	Pretuning not operating, waiting to be started by operator. See STOPPED menu.
2	IDENTIFYING	Pretune is identifying process dynamics as a result of a setpoint or output change. This process may take up to 4 to 6 process time constants. See Table 7-12.
3	CALCULATING	Identification is complete and calculation of new tuning parameters is in process. See Table 7-12.
4	COMPLETE	Calculations are complete and new parameters are ready to replace the loop's tuning parameters, if desired. See Table 7-13.

**NOTE:** While using Pretune, it is recommended that Overshoot Suppression is turned off. With overshoot suppression on, Pretune may not work or may give inaccurate tunings.

### Pretune STOPPED menu

Table 7-11 describes the Pretune STOPPED prompts.

**Table 7-11 Pretune STOPPED Prompts**

Prompt	Range/Selections	Definition
STATUS	This is a read-only prompt.	Status stopped.
PV	This is a read-only prompt.	Current process variable value of the loop being tuned.
OUTPUT	This is a read-only prompt.	Current output value of the loop being tuned.
SETPOINT	This is a read-only prompt.	Current working set point value of the loop being tuned
TUNE SET	Select which set of tuning parameters (#1 or #2) will be pretuned and installed.	If tuning a split loop, set#1 applies to loop output between 0 and +100; set#2 applies to loop output between 0 and -100.
OPTIMIZE	Select SET PT or LOAD	This optimizes the new tuning parameters according to their intended use (that is, controlling changes in setpoint or process load).
OVERSHOOT	Select YES or NO.	This determines whether or not some overshoot is acceptable in the pretune specified tuning.

*continued*

**Table 7-11 Pretune STOPPED Prompts (continued)**

Prompt	Range/Selections	Definition
OUTPUT SIZE	-100 to +100	Appears if loop is in Manual. Enter the largest change in output (+ or -), in engineering units, that the process will tolerate. The pretune will initiate and analyze this output change.
SP STEP SIZE	-100 to +100	Appears if loop is in Auto. Enter the largest change in setpoint (+ or -), in engineering units, that the process will tolerate. The pretune will initiate and analyze this setpoint change.
START		Select to start the pretune function. See <b>Before Starting Pretune</b> below.

**Before Starting Pretune**

Before starting Pretune, configure/adjust the loop as follows:

**Auto/Manual:** Either mode is acceptable. Changing the loop mode after starting pretune will abort the pretune, causing an error message to appear.

**Process Variable:** Adjust setpoint or output to bring the process variable to normal operation range. Adjusting or switching setpoints or output after starting pretune will abort the pretune, causing an error message to appear.

**Gain/Proportional Band, Reset:** Use known good settings. Or, set Gain = 1.0 (PB = 100), Reset = 1.0 and place loop in Manual mode.

**Rate:** Optional. If OFF, pretune will not calculate a Rate.

**Suppress Overshoot:** Set to OFF. Pretune may detect changes to the working setpoint and abort. Turn this setting back on after pretune is complete.

**After Starting Pretune**

After starting the pretune, do not change/adjust the loop mode, loop output, loop setpoint, or operating mode. If you do, the pretune will abort. See Pretune Abort Messages later in this section.

**Pretune IDENTIFYING & CALCULATING menus**

During IDENTIFYING and CALCULATING status, a TUNE indicator appears on all primary displays (not on menus) for the loop being pretuned.

**Table 7-12 Pretune IDENTIFYING & CALCULATING Prompts**

Prompt	Definition
STATUS	Status Identifying or Calculating. This is a read-only prompt.
PV	Current process variable value of the loop being tuned. This is a read-only prompt.
OUTPUT	Current output value of the loop being tuned. This is a read-only prompt.

**Table 7-12 Pretune IDENTIFYING & CALCULATING Prompts (continued)**

Prompt	Definition
SETPOINT	Current working set point value of the loop being tuned. This is a read-only prompt.
RUN TIME	Elapsed time since pretune was started. This is a read-only prompt.
ABORT	Select to cancel identifying and calculating and return to the stopped status.

**Pretune COMPLETE menu**

Table 7-13 describes the Pretune COMPLETE prompts.

**Table 7-13 Pretune COMPLETE Prompts**

Prompt	Definition
STATUS	Status Completed. This is a read-only prompt.
PB/GAIN	New Prop. Band or gain determined by pretune. This is a read-only prompt.
RESET	New Reset determined by pretune. This is a read-only prompt.
RATE	New Rate determined by pretune. This is a read-only prompt.
INSTALL	Select to install the new pretune values into loop's tuning parameters (specified by TUNE SET in Table 7-11.)
ABORT	Select to delete the new pretune values if you do not wish to install them.

**Pretune Abort messages**

One of the following messages is displayed when an unusual event has aborted the pretune. “PTA” means “Pretune Abort.”

**Table 7-14 Pretune Abort Messages**

Message	Meaning/User action required
PTA-WARM START	A warm start occurred during pretune. Repeat pretune.
PTA-WENT OFFLINE	Instrument went out of Online mode during pretune. Repeat pretune.
PTA-LOOP STATUS	Loop has PV that is bad (i.e. failed sensor) OR PV is a constant value such as from an upstream block in manual OR Loop has back calculation value from a downstream block that is bad or is the result of the downstream block being in manual. Repeat pretune.
PTA-AM SEL CHNGE	Loop switched between automatic and manual modes. Repeat pretune.
PTA-SP SEL CHNGE	Loop was in automatic mode and an attempt was made to switch between Setpoint #1 and Setpoint #2. Repeat pretune.
PTA-OUT MOVED	Loop was in manual mode and loop's output value changed. Repeat pretune.
PTA-SP MOVED	Loop was in automatic mode and the setpoint value changed. Repeat pretune.
PTA-LOOP OS	Loop is out of service. Fix loop before repeating pretune.
PTA-LOOP NOT CFG	Loop is not configured. Configure loop before repeating pretune.
PTA-BAD STEP SIZ	Step size is turned off. Set step size to a value before repeating pretune. See Table 7-11.
PTA-ONOFF LOOP	Cannot pretune an on/off type loop.
PTA-BAD SN RATIO	Increase step size. See Table 7-11.
PTA-BAD OSC	Repeat pretune with smaller gain or proportional band in loop.
PTA-BAD ID VALUE	Increase step size. See Table 7-11.
PTA-DB ACCESS	Unknown hardware problem. Consult service.
PTA-TASK FAIL	Unknown hardware problem. Consult service.

## 7.8 Review Programming

This item is visible only if enabled under Enable Features in the Program mode.

Select this item to see how the instrument is configured. You can view all Program mode menus as if you were in Program mode, but you cannot change anything.

## 8. Maintenance

### 8.1 Overview

This section includes information on maintenance through the Maintenance Mode menu using some off-line utility programs and diagnostics procedures.

To avoid voiding the warranty, contact your service provider before attempting any service or repair of this instrument.

Maintenance Mode is an off-line mode for maintaining proper operation of the instrument and setting defaults.

Enter Maintenance Mode by selecting "MAINTENANCE" on the "SET MODE" line of any main menu. Remember that this mode is an off-line mode.

**Table 8-1 Maintenance Mode Menu**

Menu as displayed	Function
SET MODE	Changes operating mode of instrument
CALIBRATE ANALOG INPUTS	Calibrates Analog Inputs
CALIBRATE ANALOG OUTPUTS	Calibrates Analog Outputs
OFF-LINE DIAGNOSTICS	Runs diagnostic tests to check various instrument functions
DATABASE SERVICES	Clears the configuration and/or calibration from the instrument memory. Upgrades software features.
RESET UNIT	Resets instrument to recognize changes to Main Frequency or Scan Frequency
PRODUCT INFORMATION	Displays product information
MAINS FREQUENCY	Sets the power supply frequency (50 or 60 Hz)
WARM START TIME	Sets warm start time.
DEMO	Enables simulated input values. For demonstration purposes only.

**What's in this section**

The following topics are explained in this section.

<b>Topic</b>	<b>Page</b>
Routine Maintenance	257
Set Mode	257
Calibrate Analog Inputs	257
Calibrate Analog Outputs	258
Off-line Diagnostics	259
Database Services	260
Reset Unit	260
Product Information	260
Mains Frequency	260
Warm Start Time	261
Demo	262



## 8.2 Routine Maintenance



Calibrate the instrument routinely to ensure conformity to specifications. Calibration is to be performed by qualified service personnel only.

Clean the front panel with a damp cloth. If needed, use a detergent containing no abrasives. Always clean the front panel with the bezel closed. ***Do not use solvent cleaners.***

## 8.3 Set Mode

Select this to change the operating mode to Online or Program.

### ATTENTION

Changing to ONLINE mode by pressing any of the Display buttons can cause incorrect values to be displayed. The values will correct themselves in a few seconds. To avoid this potential annoyance, change to online mode through SET MODE instead of through the Display buttons.

## 8.4 Calibrate Analog Inputs

Select an AI for calibration. Only one Analog Input is needed for calibration, regardless of the number of inputs present.



### WARNING

Disconnect power to all terminals before connecting or disconnecting calibration leads. Hazardous voltage is present on the mains terminals and may be present on other terminals. More than one switch may be required to de-energize the unit before servicing.

### ATTENTION

Time-stamp and description of successful calibrations are stored to disk in the Event File.

### Calibrating EMF Inputs

**Table 8-2 Calibrate EMF Input Procedure**

Step	Action
1	Connect an adjustable precision 25 mV - 5 V voltage source to the terminals of the selected TC or EMF input.
2	Adjust the source to 25 mV. Select the calibration voltage 25 mV and press Enter to calibrate the selected range. A message CALIBRATING will appear until calibration is complete. If it fails, a failure message is displayed.
3	Repeat for 75 mV, 1.0V and 5.0V
4	Press Menu to restore the Main Maintenance Menu when finished.

Calibrating RTD Inputs

Table 8-3 Calibrate RTD Input Procedure

Step	Action
1	Perform the appropriate EMF calibration as described above.
2	Using the same input, connect a precision variable resistor to the RTD input (Figure 8-1). The A and B leads must be of equal resistance (length).
3	For standard inputs, set the resistor to 100 ohms. Select RTD CALIBRATE 100 OHMS and press Enter. The message CALIBRATING will appear until the RTD low range calibration is complete. Repeat this step using 500 ohm resistor and RTD CALIBRATE 500 OHMS.
4	For 10 ohm copper inputs, set the resistor to 10 ohms. Select RTD CALIBRATE 10 OHMS and press Enter. The message CALIBRATING will appear until the RTD low range calibration is complete. Repeat this step using 25-ohm resistor and RTD CALIBRATE 25 OHMS.
5	Press Menu when AI calibration is complete to return to the main Maintenance menu.



Figure 8-1 RTD Calibration Connection

8.5 Calibrate Analog Outputs

For VAT calibration, a precision voltmeter is required. For CAT calibration, a precision milliammeter or a precision resistor and voltmeter is required.



**WARNING**

Disconnect power to all terminals before connecting or disconnecting calibration leads. Hazardous voltage is present on the mains terminals and may be present on other terminals. More than one switch may be required to de-energize the unit before servicing.

**ATTENTION**

Time-stamp and description of successful calibrations are stored to disk in the Event File.

**ATTENTION**

If you are calibrating an analog output that was changed from a CAT to a VAT or vice versa, make sure you put the instrument online for several seconds before calibrating.

**Table 8-4 Calibrate Analog Output Procedure**

Step	Action
1	Connect the meter to the output #1 terminals.
2	Select CALIBRATE ANALOG OUTPUTS.
3	Select OUTPUT #1 LOW. The menu will disappear and the meter will read approximately 4 mA (CAT) or 1 volt (VAT).
4	Use the Increment and Decrement buttons to adjust the meter reading to the exact low value of 1 volt or 4 mA. Press Enter when done.
5	Select OUTPUT #1 HIGH. The menu will disappear and the meter will read approximately 20 mA (CAT) or 5 Volts (VAT).
6	Use the Increment or Decrement buttons to adjust the meter reading to the exact high value. Press Enter when done.
7	Repeat steps 1-6 to calibrate other CAT or VAT outputs.
8	Press Menu to restore the main Maintenance menu.

## 8.6 Off-line Diagnostics

The following table describes the prompts.

**Table 8-5 Offline Diagnostic Prompts**

Prompt	Function
RAM SIZE (KB)	Shows amount of RAM found during power-up self-test. If less than 1024KB, replace the CPU.
KEYBOARD TEST	Select this to verify operation of each key. When each key is pressed, its name should appear onscreen. An AT keyboard can also be tested if connected.
DISPLAY TEST	Select this then press Enter to test each display color: red, green, blue, white, black. Any failed display pixels should be apparent.
DISK READ/WRITE TEST	Select this to verify read/write disk function. You must use a formatted disk. Disk data is unaffected by this test.

## 8.7 Database Services

The following table describes the prompts.

**Table 8-6 Database Services Prompts**

Prompt	Function
CLEAR CONFIGURATION ONLY	Clears all setup and configuration data entered by the user. Does not clear calibration.
CLEAR CALIBRATION ONLY	Clears all analog data calibration values. Does not clear configuration.
CLEAR ALL MEMORY	Clears the Instrument memory of all programming, tuning data, setups, etc. and restores the original factory-set default values for all parameters and functions and calibration.
FULL UPGRADE	Upgrades all function blocks of the instrument from a disk file with .LNF extension. Overwrites all function blocks. Executes Clear All Memory after this service.
INCREMENTAL UPGRADE	Upgrades the instrument with the desired options from a disk file with .LNI extension. Does not affect existing function blocks or configuration.
SOFTWARE UPGRADE	Upgrades product software from disk.

## 8.8 Reset Unit

Select this item to reboot the unit after making changes to Mains Frequency. This function does **not** clear memory.

## 8.9 Product Information

Select this item to display the product identification, software version number, PROM part number, and serial number.

## 8.10 Mains Frequency

Select either 50 Hz or 60 Hz. Afterward you must select RESET UNIT to activate this change.

## 8.11 Warm Start Time

The instrument will start up in one of three modes based on the length of time power is off.

### First Time Start

First time start occurs when the unit is being powered up for the first time or when the memory clear services maintenance routine is executed. All configuration and calibration is cleared and all parameters are set to factory defaults. See "DATABASE SERVICES" Section 8.7.

### Cold Start

Cold start occurs when the unit is without power for a period longer than 90 minutes or if the reset unit maintenance routine is executed. See Section 8.8 Reset Unit. In cold start operation, all RAM buffers (storage and display) are cleared and accumulated values of some function blocks (Calculated Value timers, totalizers, and control loop integral) are reset to initial values. The cold start operation retains the loop operating status of auto or manual and setpoint 1 or setpoint 2. The loop output will be set to zero (0) unless configured to use a Failsafe value for the analog output.

*No Data collected and stored to floppy disk before the onset of cold Start is lost.*

Data storage is automatically resumed after a Cold Start; a maximum of 1 minute of buffered data will be lost due to a Cold Start. If a new disk was inserted into the floppy drive while power was off, you must initialize the new disk to resume data storage.

### Warm Start

If power is off for less than 90 minutes, a warm start will be used during power-up. All buffered data prior to power loss is retained and accumulated values in Calculated Value timers and totalizers are retained. Control loop output values are also retained. Setpoint Profilers resume where they left off. If power is off for more than the warm up start time, a cold start operation will occur.

Warm start times available (in minutes): 1, 2, 3, 4, 5, 10, 15, 20, 30, 60, 90, None

Note that all data storage schedules that have been initialized or started via the ON LINE mode DATA STORAGE SETUP menu will automatically resume their execution upon the occurrence of a Warm Start.

## 8.12 Demo

This item is intended primarily for sales demonstrations. It causes the instrument to display a series of simulated values.

---

### ATTENTION

**Never** turn the demo on in an instrument that has already been configured to support its true application without first saving the instrument's configuration to floppy disk. Selecting DEMO will reconfigure Analog Inputs 1 through 4 and Discrete Input 1. When DEMO is turned off, the demo's function block configurations are still used but their inputs are tied to the hardware and are no longer simulated.

---

## 9. On-Site Adjustments

### 9.1 Removing the Circuit Card Assembly

Remove the circuit card assembly only when doing the following procedures.

1. Changing an analog output from CAT to VAT type, or from VAT to CAT.
2. Terminating or unterminating an instrument in a serial communications link.
3. Changing numbers of Discrete Inputs/Discrete Output combinations on the open collector output cards.

Avoid opening the instrument unless absolutely necessary. Damage to the instrument can result unless proper procedures are followed.



#### ATTENTION

- Contact your service representative before attempting service. Unauthorized repairs of an instrument may void the warranty.
- Before removing the chassis assembly, be sure to take proper safeguards against electrostatic discharge, such as wearing an approved grounding strap.

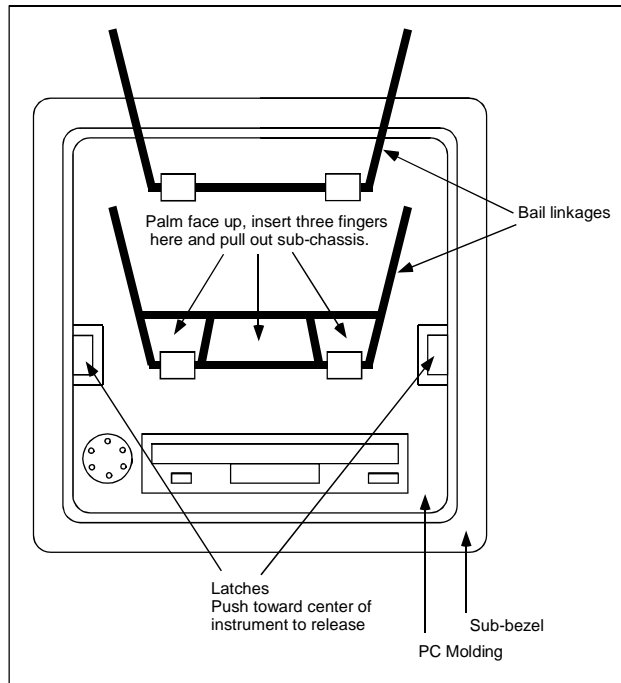
#### ATTENTION

Time-stamp and description of successful calibrations are stored to disk in the Event File.

### Circuit Card Removal and Replacment Procedures (VPR100 & VRX100)

Table 9-1 Circuit Card Removal Procedure (VPR100 & VRX100)

Step	Action
1	Open the front display assembly by pressing the button underneath the bezel to release the latch and then pulling the bezel forward and up. Press the bottom edge of the bezel as you press the button and the latch will release easily.
2	Lift the front bezel up and out until it locks in the open position.
3	With your palm face up, insert 2 fingers into the 2 loops of the bottom bail linkage. (Some instruments have a single loop.) See Figure 9-1.
4	With your free hand, one at a time push each latch toward the center of the instrument while gently pulling with the other hand on the bail linkage. You may have to gently jiggle and pull on the bail linkage to help release the latches.
5	Once the latches are free of the sub-bezel, pull on the bail linkage to slide the circuit card assembly out of the instrument.
6	The sub-chassis will strike a stop when it is almost all the way out. Lift the back end of the card cage to clear the stop and the entire assembly can be removed. There are no cables which need to be disconnected.



**Figure 9-1 Circuit Card Removal (VPR100 & VRX100)**

**Table 9-2 Circuit Card Replacement Procedure (VPR100 & VRX100)**

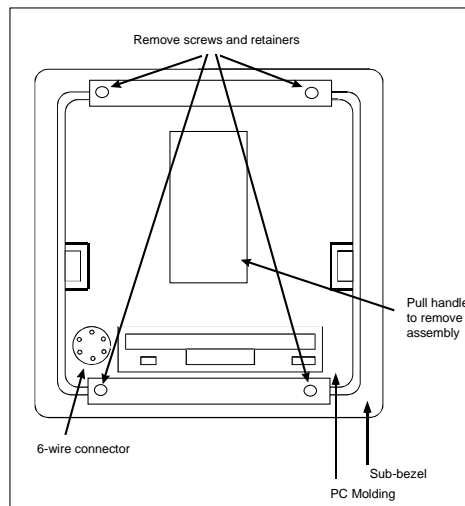
Step	Action
1	Place the rear of the card cage assembly into the opening. Lift it up and over the limit stop, then push it all the way back into the housing.
2	Press the unit back to fully engage the rear card edge connectors and until both front latches snap into place and the PC molding is flush with the sub-bezel. See Figure 9-1.
3	Pull on the lower bail linkage to verify that the unit is fully seated and firmly latched, then close the front display assembly. Engage the top edge of the bezel first, then swing in the bottom and press it in until the button latch snaps into place.



**Circuit Card Removal and Replacement Procedures (VRX150)**

**Table 9-3 Circuit Card Removal Procedure (VRX150)**

Step	Action
1	Remove the 4 screws from the top and sides of the display front. Do not drop the display front.
2	Disconnect the 2 ribbon cables at the display.
3	Disconnect the 6-wire connector at the front of the assembly next to the floppy disk drive.
4	With one hand, pull the handle to remove the circuit card assembly out of the instrument.
5	The assembly sub-chassis will strike a stop when it is almost all the way out. Lift the back end of the card cage to clear the stop and the entire assembly can be removed. There are no cables that need to be disconnected.



**Figure 9-2 Circuit Card Removal (VRX150)**

**Table 9-4 Circuit Card Replacement Procedure (VRX150)**

Step	Action
1	Place the rear of the card cage assembly into the opening. Lift it up and over the limit stop, then push it all the way back into the housing.
2	Press the unit back to fully engage the rear card edge connectors and until both front latches snap into place and the PC molding is flush with the sub-bezel. See Figure 9-2.
3	Re-connect the cables and wires by reversing steps 1-3 of Table 9-3.

## 9.2 Changing Analog Input Ranges

Expanded input ranges are available by changing jumper settings on the AI card in Slot #4 (leftmost card as you face the front of the instrument) and programming the AI prompts as shown in Table 9-5.

**Table 9-5 Settings for expanded AI ranges**

Input Range	Make these jumper settings		Under Program menu, program the selected AI as follows
	A*	B*	
Standard	Closed	Open	Standard range
0-10V	Open	1-2	Range low: 0 Range high: 10 Indirect Circuit low: 0 Circuit high: 2.5 Electrical Units: Volts
0-20V	Open	1-2	Range low: 0 Range high: 20 Indirect Circuit low: 0 Circuit high: 5 Electrical Units: Volts
±10V	Open	2-3	Range low: -10 Range high: 10 Indirect Circuit low: -75 Circuit high: 75 Electrical Units: mV
±20V	Open	2-3	Range low: -20 Range high: 20 Indirect Circuit low: -150 Circuit high: 150 Electrical Units: mV
<p>*To identify jumpers for each AI, locate jumper labels (at rear of AI card nearest terminals) and cross-reference to the corresponding AI below.</p> <p><u>For this AI      Use these jumpers</u></p> <p>AI1              A=W3, B=W4                      AI2              A=W5, B=W6                      AI3              A=W7, B=W8                      AI4              A=W9, B=W10                      AI5              A=W11, B=W12                      AI6              A=W13, B=W14</p>			

### 9.3 Changing the CAT/VAT Setting

S1 DIP switch settings determine whether an analog output is CAT type or VAT type (Table 9-6).

**Table 9-6 S1 DIP Switch Default Settings**

	S1-1	S1-2	S1-3	S1-4
CAT	OFF	OFF	ON	ON
VAT	ON	ON	OFF	OFF

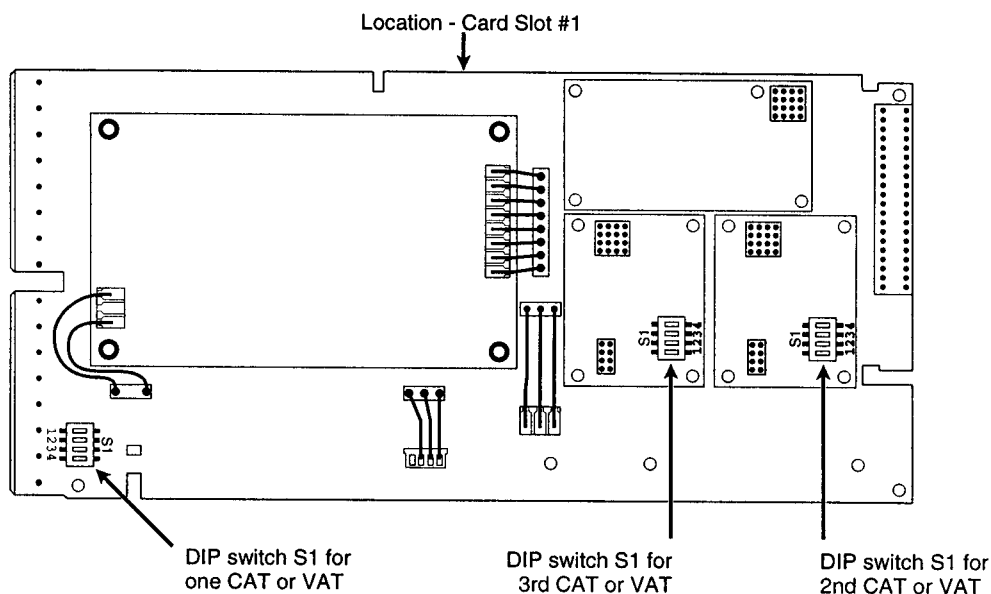
Circuit card slot#1 contains the S1 DIP switch for each analog output. See

Figure 9-3 for switch locations.

To gain access to the circuit cards, see Section 9.1.

#### ATTENTION

After changing an S1 DIP switch's settings, you must recalibrate the analog outputs. Also, make sure you put the instrument in online mode for at least several seconds before you calibrate the analog output.



**Figure 9-3 Locations Of AO DIP Switch S1**

## 9.4 Changing number of DIs/DOs

To change the number of Discrete Inputs and Discrete Outputs, remove the circuit card as explained in Section 9.1. Refer to Figure 9-4 and Table 9-7 for DIP switch location and settings.

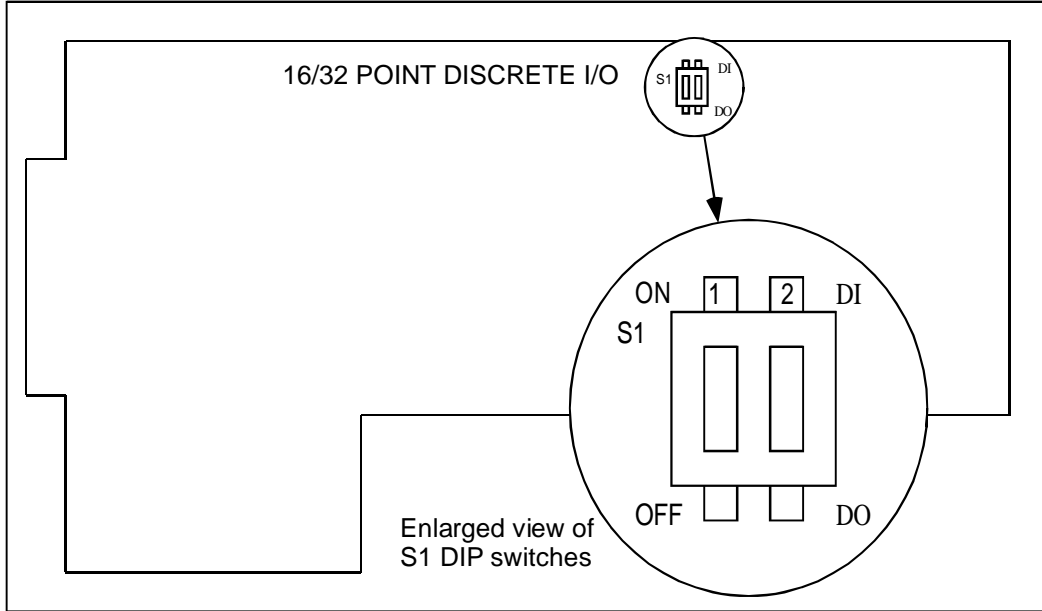


Figure 9-4 Location Of DIP Switch S1 On Discrete I/O Card

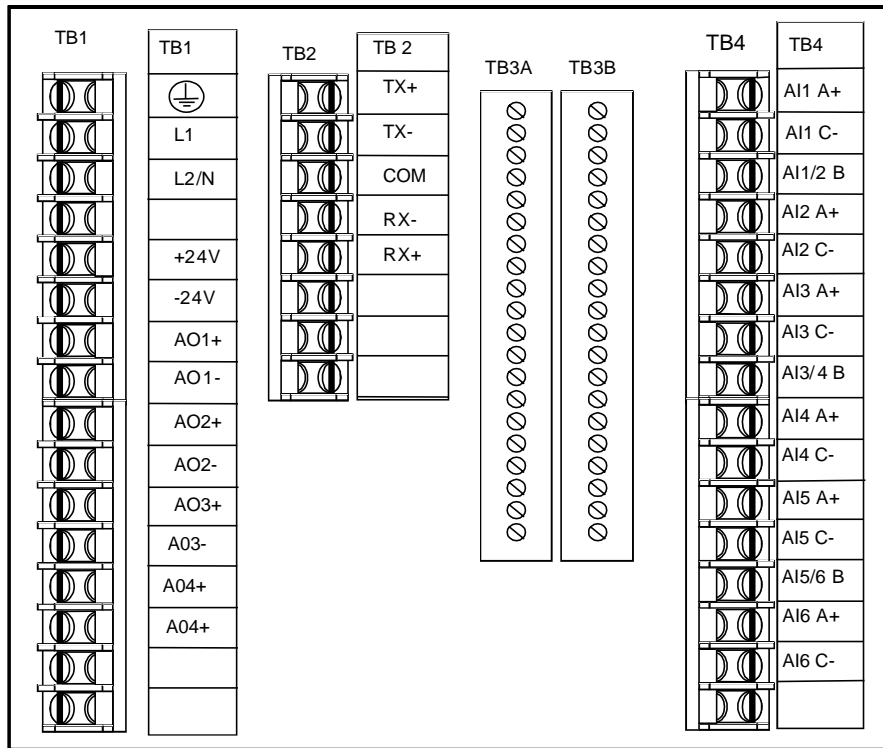


Figure 9-5 Instrument's Rear Terminals

**Table 9-7 DIP Switch Settings For DI/DO Combinations**

Use these S1 DIP switch settings...							
S1-1: ON		S1-1:OFF		S1-1: OFF		S1-1: ON	
S1-2: OFF		S1-2:ON		S1-2: OFF		S1-2: ON	
For these DI/DO combinations on TB3A and TB3B							
16 DI/16 Open Collector Outputs		16 DI/16 Open Collector Outputs		8 DI/24 Open Collector Outputs		24 DI/8 Open Collector Outputs	
TB3A	TB3B	TB3A	TB3B	TB3A	TB3B	TB3A	TB3B
DI9	DI1	DO9	DI1	DO9	DI1	DI9	DI1
DI10	DI2	DO10	DI2	DO10	DI2	DI10	DI2
DI11	DI3	DO11	DI3	DO11	DI3	DI11	DI3
DI12	DI4	DO12	DI4	DO12	DI4	DI12	DI4
DI13	DI5	DO13	DI5	DO13	DI5	DI13	DI5
DI14	DI6	DO14	DI6	DO14	DI6	DI14	DI6
DI15	DI7	DO15	DI7	DO15	DI7	DI15	DI7
DI16	DI8	DO16	DI8	DO16	DI8	DI16	DI8
COM	COM	COM	COM	COM	COM	COM	COM
COM	COM	COM	COM	COM	COM	COM	COM
COM	COM	COM	COM	COM	COM	COM	COM
COM	COM	COM	COM	COM	COM	COM	COM
DO17	DO1	DI17	DO1	DO17	DO1	DI17	DO1
DO18	DO2	DI18	DO2	DO18	DO2	DI18	DO2
DO19	DO3	DI19	DO3	DO19	DO3	DI19	DO3
DO20	DO4	DI20	DO4	DO20	DO4	DI20	DO4
DO21	DO5	DI21	DO5	DO21	DO5	DI21	DO5
DO22	DO6	DI22	DO6	DO22	DO6	DI22	DO6
DO23	DO7	DI23	DO7	DO23	DO7	DI23	DO7
DO24	DO8	DI24	DO8	DO24	DO8	DI24	DO8

## 9.5 Setting The Communications Link Termination Jumper

The last unit in the communications link must be terminated and all other slave units in the link must be unterminated, or data transfer will not function properly.

Units are shipped from the factory with terminations set for unterminated operation.

To terminate an instrument, jumpers W2 and W3 on card #046925 in Slot 1 must be both set in the 1-2 position. To remain unterminated, jumper W2 and W3 must be in the 2-3 position. See Figure 9-6.

To gain access to the circuit card, follow instructions in Section 9.1.

For serial communication wiring, see Communications Wiring in Section 2.5.

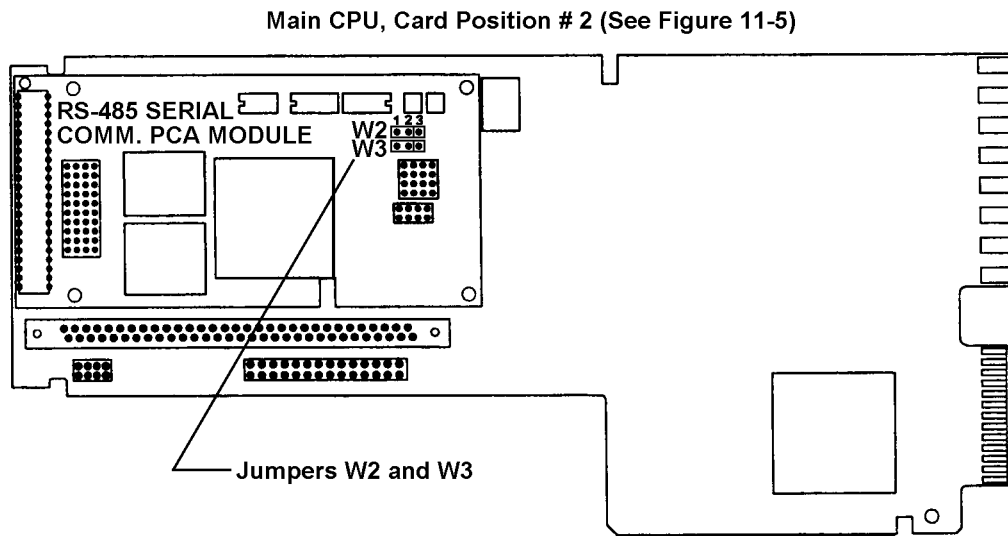


Figure 9-6 Location of Jumpers W2 and W3

## 9.6 Diagnostic Messages

The instrument executes diagnostic routines during instrument start-up and during maintenance procedures such as calibration. It also monitors online operation for both process faults and instrument errors.

### Error messages

Table 9-8 shows messages that may appear on the instrument displays if a diagnostic condition is detected, along with the action you should take.

**Table 9-8 Diagnostic Error Messages**

Message	Description	User action														
INPUT FAIL	The analog input is either open/shorted	Check input devices for open or short.														
	The analog input has been exposed to electromagnetic noise.	See Section 2 for proper wiring techniques.														
	The analog input is out of range	<p>Each AI type uses one of four gain settings. The maximum voltage normally supplied by the AI source determines which gain setting is used, and therefore its measurable range.</p> <table border="1"> <thead> <tr> <th>Gain</th> <th>Low signal</th> <th>High signal</th> </tr> </thead> <tbody> <tr> <td>25mV</td> <td>-30mV</td> <td>30mV</td> </tr> <tr> <td>75mV</td> <td>-90mV</td> <td>90mV</td> </tr> <tr> <td>1V</td> <td>-200mV</td> <td>1200mV</td> </tr> <tr> <td>5V</td> <td>-300mV</td> <td>5200mV</td> </tr> </tbody> </table> <p>Example: AI1 is 1 to 5V range, therefore gain is 5V, therefore input failure if <math>-300\text{mV} &gt; \text{signal} &gt; 5200\text{mV}</math>.</p>	Gain	Low signal	High signal	25mV	-30mV	30mV	75mV	-90mV	90mV	1V	-200mV	1200mV	5V	-300mV
Gain	Low signal	High signal														
25mV	-30mV	30mV														
75mV	-90mV	90mV														
1V	-200mV	1200mV														
5V	-300mV	5200mV														
FLOAT PT ERROR	A floating point calculation error has occurred. (divide by zero, underflow, overflow).	Check Free Form Math and Math CV inputs for division by 0. Also check for input values producing a underflow or overflow error (that is, calculation is not between $-1 \times 10^{-38}$ and $-3 \times 10^{-38}$ or is not between $1 \times 10^{-38}$ and $3 \times 10^{-38}$ ).														
CHECKSUM ERROR	An error was detected in the database of one or more function blocks. The affected function blocks are reset to their defaults.	Inspect entire instrument configuration and reconfigure as needed.														

## ATTENTION

Be advised that the **INPUT FAIL** diagnostic will continue to be displayed even after its cause has disappeared. After verifying that this diagnostic's cause has been corrected, you may clear the **INPUT FAIL** message from all **ON LINE** screens by performing one of the following sequences of steps.

1) Acknowledge the INPUT FAIL diagnostic.

From the **ON LINE** main menu, select **ACCESS SUMMARIES**. Select **DISPLAY DIAGNOSTICS**. Use the **<Up>** and **<Down>** buttons to highlight the **INPUT FAIL** diagnostic(s) that you wish to acknowledge and then press **<Enter>**. Once the diagnostic has been acknowledged, it will still be listed in the **DISPLAY DIAGNOSTICS** screen but will no longer be displayed on any **ON LINE** screen.

2) Delete the INPUT FAILURE diagnostic.

From the **ON LINE** main menu, select **ACCESS SUMMARIES**. Select **DELETE ALL DIAGNOSTICS**. Once this menu choice has been executed, all diagnostic messages will be deleted from the **DISPLAY DIAGNOSTICS** screen and will no longer be displayed on any **ON LINE** screen.

---

During power-up, if an analog input is open or is out of range, the setpoint and process variable values will display OFF and the loop's AUTO mode is disabled. Check connections to determine problem. During calibration if the input reference voltages supplied by the technician are outside acceptable limits a "CALIB FAIL" message will be generated.



## Internal error messages

In addition to diagnostic messages, error messages are presented to indicate an internal fault. To correct the problem, Table 9-9 lists suggested actions you should take, in the order you should take them. To acknowledge or clear the error message, see Section 7.4 Access Summaries.

**Table 9-9 Internal Error Messages**

Error message	Suggested Action
NONV RAM ERROR	<ol style="list-style-type: none"> <li>1. Reduce the configuration by eliminating function.</li> <li>2. Call service provider.</li> </ol>
PROCESSOR EXCEPTION	<ol style="list-style-type: none"> <li>1. Reset unit.</li> <li>2. Clear configuration and reload.</li> <li>3. If message recurs, replace CPU.</li> </ol>
PROCESSOR RESET	<ol style="list-style-type: none"> <li>1. Reset unit.</li> <li>2. Clear configuration and reload.</li> <li>3. If message recurs, replace CPU.</li> </ol>
TASK INIT FAILURE	<ol style="list-style-type: none"> <li>1. Reset unit.</li> <li>2. Clear configuration and reload.</li> <li>3. If message recurs, replace CPU.</li> </ol>
QUEUE READ FAILURE	<ol style="list-style-type: none"> <li>1. Reset unit.</li> <li>2. Clear configuration and reload.</li> <li>3. If message recurs, replace CPU.</li> </ol>
RESPONSE FAILURE	<ol style="list-style-type: none"> <li>1. Reset unit.</li> <li>2. Clear configuration and reload.</li> <li>3. If message recurs, replace CPU.</li> </ol>
REQUEST FAILURE	<ol style="list-style-type: none"> <li>1. Reset unit.</li> <li>2. Increase scan rate to higher time; for example, from 500 msec to 1 second.</li> <li>3. Clear configuration and reload it.</li> <li>4. If message recurs, replace the CPU.</li> </ol>
AED REPORT FAILURE	<ol style="list-style-type: none"> <li>1. Reset unit.</li> <li>2. Increase scan rate to higher time; for example, from 500 msec to 1 second.</li> <li>3. Clear configuration and reload it.</li> <li>4. If message recurs, replace the CPU.</li> </ol>
AED HANDSHAKE FAILURE	<ol style="list-style-type: none"> <li>1. Reset unit.</li> <li>2. Increase scan rate to higher time; for example, from 500 msec to 1 second.</li> <li>3. Clear configuration and reload it.</li> <li>4. If message recurs, replace the CPU.</li> </ol>
FB TASK OVERRUN	Increase scan rate to higher time; for example, from 500 msec to 1 second.
AI TASK OVERRUN	<ol style="list-style-type: none"> <li>1. Check for noise. See Appendix B for noise suppression.</li> <li>2. Increase scan rate to higher time; for example, from 500 msec to 1 second.</li> </ol>

*continued*

**Table 9-9 Internal Error Messages** (continued)

Error message	Suggested Action
SLOT CARD FAILURE	<ol style="list-style-type: none"> <li>1. Check for noise. See Appendix B for noise suppression.</li> <li>2. Check AI card connection.</li> <li>3. Replace AI card.</li> </ol>
STORAGE FAILURE	<ol style="list-style-type: none"> <li>1. Check for bad floppy disk.</li> <li>2. Run disk diagnostic on the disk drive.</li> <li>3. Check seating of floppy cables.</li> <li>4. Replace CPU.</li> </ol>
DATA STORAGE STATUS LOST	<ol style="list-style-type: none"> <li>1. Check for bad floppy disk.</li> <li>2. Run disk diagnostic on the disk drive.</li> <li>3. Check seating of floppy cables.</li> <li>4. Replace CPU.</li> </ol>
RJ FAILURE	<ol style="list-style-type: none"> <li>1. Check reference junction sensor connection.</li> <li>2. Check AI card.</li> <li>3. Replace CPU.</li> </ol>
CLOCK FAILURE	<ol style="list-style-type: none"> <li>1. Reprogram clock.</li> <li>2. Reset unit.</li> <li>3. Change lithium battery on CPU card.</li> <li>4. Replace CPU.</li> </ol>
CLOCK RESET	<ol style="list-style-type: none"> <li>1. Reprogram clock.</li> <li>2. Reset unit.</li> <li>3. Change lithium battery on CPU card.</li> <li>4. Replace CPU.</li> </ol>
TIMING ERROR	<ol style="list-style-type: none"> <li>1. Reprogram clock.</li> <li>2. Reset unit.</li> <li>3. Change lithium battery on CPU card.</li> <li>4. Replace CPU.</li> </ol>
TASK ERROR	<ol style="list-style-type: none"> <li>1. Reset unit.</li> <li>2. Clear configuration and reload.</li> <li>3. If message recurs, replace CPU.</li> </ol>
RAM ERROR	<ol style="list-style-type: none"> <li>1. Run RAM diagnostic.</li> <li>2. Replace CPU.</li> </ol>
COMM PORT ERROR	<ol style="list-style-type: none"> <li>1. Check communications card seating.</li> <li>2. Replace communications card.</li> <li>3. Replace CPU.</li> </ol>

## 9.7 Loop Error Indicators

When a loop's PV, SP2, or other parameter fails, the loop switches to its default/failsafe condition, indicated by certain display symbols flashing. To return the loop to its desired condition, correct the failure. Then, if the loop's LATCHING is NO, the loop will return to normal automatically. If LATCHING is YES, also perform the action needed to return the loop to normal.

**Table 9-10 Abnormal Loop Conditions And Indicators**

Desired Condition	Abnormal Condition	Default condition (Failsafe)	Flashing symbols	Action needed (if LATCHING = YES)
Auto & SP2	SP2 Failure	Working SP=SP1	SP2	Select SP1 then SP2
Manual & SP2	SP2 Failure	Working SP=SP1	SP2	Select SP1 then SP2
Auto & SP2	SP2 & PV Failure	Working SP=SP1 Mode = Suspend Auto* Output = Failsafe	SP2 AUTO MAN** PV	Select SP1 then SP2 Select Manual then Auto
Manual & SP2	SP2 & PV Failure	Working SP = SP1 Mode = Manual Output = Last value	SP2 PV	Select SP1 then SP2
Auto & SP1/SP2	PV Failure or Force Remote Manual Failure or Output Tracking Failure or Feedforward Failure	Mode = Suspend Auto* Output = Failsafe	AUTO MAN** PV	Select Manual then Auto
Manual & SP1/SP2	PV Failure	Mode = Manual Output = Last Value	PV	None required
Auto & SP1/SP2	see below***	Mode = Suspend Auto* Output = Back Calc. Value	AUTO MAN	None required
Auto & SP1/SP2	Force Remote Manual	Mode = Suspend Auto* Output = Tracking value	AUTO	None required
<p>*Due to the abnormal condition the loop cannot be in Auto and therefore is in a temporary mode which forces the output as indicated.</p> <p>**If loop feedback is not connected to an AO, or if loop type is ON/OFF, then MAN will be steady, not flashing.</p> <p>***Status from a downstream function block indicates that there is no path to final output element. For example, the secondary control loop of cascade configuration was changed to manual mode.</p>				



## 10. Error Messages

### Overview

Sometimes errors occur while you are programming or loading a configuration into your instrument. In most cases the instrument displays a descriptive error message. For example, if you try to program a function block incorrectly, the instrument tells you the problem.

Table 10-1 lists these error message along with a description of each one and what action to take.

**Table 10-1 Error Messages**

Error	Description	User Action
Block Phase Greater Than Block Period	In Periodic Timer CV, the phase (start time) is greater than the period. For example, the start time is 8:00 and the period is 4:00.	Change Period to greater than phase (Start Time) or change Start Time to less than Period.
Channel Does Not Exist	A channel was loaded that does not exist. For example, you loaded a dual loop configuration into a single loop instrument.	Verify programming of affected function block.
Circuit Limits Equal	Indirect circuit low/circuit high limits must be unequal.	Change to unequal limits.
Condition Type Out of Range	Condition Type (Compare, Logic, Free form Logic) is out of range. Probably caused by someone incorrectly editing the configuration file or by a corrupt .LNC file.	Verify programming of affected function block.
Desired F <sub>0</sub> Value Not Programmed or Less Than Zero	In the F <sub>0</sub> Sterilization CV, desired F <sub>0</sub> is not programmed or is less than zero.	Change F <sub>0</sub> value to greater than zero.
High Limit Outside of circuit.	AI circuit high limit is > voltage limit of 5200 mV.	Change limit to within specified limits for that type
High Output Limit Greater than 20	A current output (CAT) high output limit cannot be greater than 20	Decrease high limit
High Output Limit Greater Than 5	A voltage output (VAT) high output limit must not be greater than 5	Decrease high limit
Hysteresis Less Than Zero	Alarm Hysteresis parameter should be greater than or equal to zero.	Increase Hysteresis.
Impulse Time less than or Equal to 0	Impulse time on a time proportioning/duration adjusting output (DAT) output cannot be less than or equal to zero.	Increase impulse time
Incompatible Curve Type	AI is custom type, thermocouple class, reference junction enabled but Y values are not always increasing or not always decreasing.	Reprogram curve so that for all n: $Y_n > Y_{n+1}$ or $Y_n < Y_{n+1}$

**Table 10-1 Error Messages** (continued)

Error	Description	User Action
Incorrect Input coordinates	The Advanced Splitter CV was programmed with input limits for Output#2 (A2) only, or for Output#1 & #3 (A1 & A3) only, or for Output#3 (A3) only.	Re-program input limits for Output#1 only, Outputs #1 & #2, or Outputs #1, #2, & #3.
Incorrect Number of Parameters for function	The function was not programmed with the minimum number of parameters. for example, the Math CV requires at least 2 inputs to function properly.	Program function with at least the minimum number of parameters.
Incorrect Output Coordinates	The Advanced Splitter CV was programmed with output limits for Output#2 (A2) only, or for Output#1 & #3 (A1 & A3) only, or for Output#3 (A3) only.	Re-program output limits for Output#1 only, Outputs #1 & #2, or Outputs #1, #2, & #3.
Invalid Algorithm Code	Bad algorithm code has been given, bad algorithm choice. Probably caused by someone incorrectly editing the configuration file or by a corrupt .LNC file.	Verify programming of affected function block.
Invalid Block Number	Probably caused by someone incorrectly editing the configuration file or by a corrupt .LNC file.	Verify programming of affected function block.
Invalid Block Type	Probably caused by someone incorrectly editing the configuration file or by a corrupt .LNC file.	Verify programming of affected function block.
Invalid Channel in Point spec	Invalid channel has been found	Verify programming of affected function block.
Invalid Equation	Free form math equation is invalid.	Check equation.
Invalid Function Block Request	Probably caused by someone incorrectly editing the configuration file or by a corrupt .LNC file.	Verify programming of affected function block.
Invalid Index code	Probably caused by someone incorrectly editing the configuration file or by a corrupt .LNC file.	Verify programming of affected function block.
Invalid Input Connection	Function block is programmed with wrong input type. Probably caused by someone incorrectly editing the configuration file or by a corrupt .LNC file.	Verify programming of affected function block.
Invalid Machine Update Rate	Bad machine scan rate	Re-enter machine scan rate.
Invalid Parameter Code	Bad parameter code has been found. Generally caused by transferring configurations between instruments with different software versions.	Verify programming of affected function block.
Invalid Parameter for Data Type	Probably caused by someone incorrectly editing the configuration file or by a corrupt .LNC file.	Verify programming of affected function block.
Invalid Tag	Probably caused by someone incorrectly editing the configuration file or by a corrupt .LNC file.	Verify programming of affected function block.

Table 10-1 Error Messages (continued)

Error	Description	User Action
Invalid Tag Request	Probably caused by someone incorrectly editing the configuration file or by a corrupt .LNC file.	Verify programming of affected function block.
Invalid Type in Point Spec	A class of block was detected that is invalid for the product.	Verify programming of affected function block.
Lag or Delay Less than Zero	AI lag or delay is less than zero	Change lag or delay to greater than or equal to zero.
Low Limit Outside of Circuit	AI circuit low limit is < voltage limit of -500 mV.	Change circuit low limit to > -500 mV.
Low limit Outside of Table	For thermocouple or RTD, Range Low limit is < the low limit for that type.	Change limit to within specified limits for that type. (Table 4-6)
Low Output Limit less than Zero	A current output (CAT) or voltage output (VAT) low limit is less than zero.	Change current output (CAT) or voltage output (VAT) low limit to greater than or equal to zero.
Monthly Periods Must Be Phased	Periodic Timer CV period is monthly but no phase is defined	Change Periodic Timer phase.
No Room for Function Block	System has used all allocated function blocks.	Verify programming of affected function block.
Number of Frames Out of Range	Rolling Average CV # of Samples is less than 1 or greater than 60.	Change # of Samples to 1-60.
Out of EEPROM Memory	No more static memory or EEPROM memory	Verify programming of affected function block.
Out of RAM Memory	No more RAM available	Verify programming of affected function block.
Output Limits Equal	Output (range) limits (low and high) must be unequal.	Change to unequal limits
Pairs Inconsistent	Applies to custom AI or Function Generator CV. Curve has Xn but no Yn or vice versa. Curve does not have at least 2 X,Y pairs.	Program a Y for each X or vice versa. Program at least 2 X's and 2 Y's.
Request Made with Invalid Tag	Probably caused by someone incorrectly editing the configuration file or by a corrupt .LNC file.	Verify programming of affected function block.
Requires a Deviation Parameter	Deviation alarm does not contain deviation.	Program alarm with deviation.
Requires Input Parameter	Alarm does not contain an input.	Program alarm with input.
Requires Setpoint Parameter	Alarm does not contain a setpoint.	Program alarm with a setpoint.
RJ Not in Curve	AI is custom type, class thermocouple, RJ enabled but curve does not contain 0-65 degrees C (32-149 degrees F).	Y values must contain 0-65 degrees C (32-149 degrees F).

**Table 10-1 Error Messages** (continued)

Error	Description	User Action
Temperature Constant Not Programmed or Less Than Zero	F0 Sterilization CV Temperature constant is not programmed or is less than zero.	Program Temperature constant with value greater than or equal to zero.
Temperature Input Not Programmed or Less Than Zero	F0 Sterilization CV Temperature Input is not programmed or is less than zero.	Program Temperature input with value greater than or equal to zero.
Temperature Reference Not Programmed or Less Than Zero	F0 Sterilization CV Reference Temperature is not programmed or is less than zero.	Program Reference Temperature with value greater than or equal to zero.
Trend Has Too Many Points For Rate Selected	Data Storage cannot store more than 3 points at 1/4 second scan rate.	Change number of points to be compatible with scan rate.
Type Does Not Exist	A function block type was loaded that does not exist. For example, you loaded a Profile but the unit does not have the Profile option.	Re-program or re-load correctly.
Type Incompatible With Hardware	Analog output type is different from hardware setting. For example, analog output is programmed as current output (CAT) but hardware is set to voltage output (VAT).	Change programming to be compatible the with hardware or vice versa, then reload configuration or reconfigure the block.
Type Requires Hardware	Hardware is missing for the programmed analog output or discrete output relay.	Either ignore the message knowing that those particular points did not get loaded or verify configuration and make sure that the points that are in the configuration match the hardware components.
Undefined Function Block Request	Internal Error	No user action
Value Written to Indirected Point	An input has been connected and user has tried to write a value to that input. For example, if a control loop setpoint is connected to AI1 OV, you will receive this message if you try to change the loop setpoint online.	Avoid changing connected values.
X Axis Must Increase	Appears if AI is custom type or CV is Function Generator and if $X_n \geq X_{n+1}$ .	Re-program $X_n < X_{n+1}$ .
X Axis Not Increased Enough	Appears if AI is custom type or CV is Function Generator and if X does not increase by at least 0.00001.	Re-program X.
Y Axis Not Increased Enough	Appears if AI is custom type or CV is Function Generator and if Y does not change by at least 0.00001.	Re-program Y.



## 11. Parts

All replacement parts for the instrument are consolidated into the replacement parts kits shown in the list that follows. The parts comprising each kit are pictured in the referenced figures. To obtain a particular replacement part, order the appropriate Kit Part Number. Parts apply to all products unless otherwise noted.

**Table 11-1 Parts**

<b>Kit Part Number</b>	<b>Kit Description</b>	<b>See</b>
51197787-501	Case Assembly Replacement Kit	"Kit #1" in Figures 11-2, 11-7, 11-8
51404685-501	Portable Case Replacement Parts	"Kit #2" in Figure 11-3
51197973-501	Rear Terminal Block Kit	"Kit #3" in Figures 11-2, 11-7, 11-8
51404680-501	VRX/VPR100 Video Display Replacement Kit	"Kit #4" in Figure 11-2
51404909-501	VRX150 Video Display Replacement Kit	Figure 11-5
51404790-501	VPR100/VRX100 CPU Board Replacement kit	"Kit #7" in Figure 11-6
51404790-502	VRX150 CPU Board Replacement kit	"Kit #7" in Figure 11-6
51197804-501	2 Point Analog Input Module	"Kit #8" in Figure 11-9
51404568-501	6 Point Analog Input Board Replacement Kit	"Position #4" in Figure 11-6
51404537-501	12 Point Analog Input Board Replacement Kit	"Position #4" in Figure 11-6
51404605-501	Analog Output Base Board Replacement Kit (1 output)	"Kit #10" in Figure 11-6
51404605-502	Analog Output Base Board Replacement Kit (2 outputs)	"Kit #10" in Figure 11-6
51404605-503	Analog Output Base Board Replacement Kit (3 outputs)	"Kit #10" in Figure 11-6
51404605-504	Analog Output Base Board Replacement Kit (4 outputs)	"Kit #10" in Figure 11-6
51197801-501	DI/DO Motherboard Printed Circuit Assembly Replacement Kit	"Kit #11" in Figure 11-6
51197803-501	Main Power Supply Replacement Kit	"Kit #12" in Figure 11-6
51404568-501	24 Vdc Power Supply Replacement Kit	"Kit #33" in Figure 11-6
51197805-501	Dual Mechanical Relay Output Module Replacement Kit	"Kit #13" in Figure 11-6
51197808-501	Dual Solid State AC Discrete Output Module Replacement Kit	"Kit #14" in Figure 11-6
51197809-501	Dual Solid State DC Discrete Output Module Replacement Kit	"Kit #15" in Figure 11-6
51197810-501	Three Discrete Inputs PCA Module Replacement Kit	"Kit #16" in Figure 11-6

Kit Part Number	Kit Description	See
51197811-501	Current/Voltage Analog Output PCA Module Replacement Kit	"Kit #17" in Figure 11-6
51197812-501	RS-485 Serial Communications PCA Module Replacement Kit	"Kit #18" in Figure 11-6
51197813-501	Isolated Analog Output Power Supply Module Replacement Kit	"Kit #19" in Figure 11-6
51404680-502	VRX/VPR100 Miscellaneous Display Hardware Kit and keyboards	"Kit #23" in Figure 11-4, 11-6
51404909-502	VRX150 Miscellaneous Display Hardware Kit	Figure 11-5
51197816-501	Front Plane Replacement Kit	"Kit #24" in Figure 11-6
51197818-501	Floppy Disk Drive Replacement Kit	"Kit #26" in Figure 11-6
51197819-501	Miscellaneous Hardware Kit	"Kit #27" in Figures 11-6, 11-7, 11-8
51197820-501	Instrument Panel Mounting Hardware Kit	"Kit #28" in Figure 11-1
51309456-501	16 Point DI/DO Printed Circuit Assembly Replacement Kit	"Kit #29" in Figure 11-6
51404540-501	12 Point AI/16 Point DI/DO Back Plane Replacement Kit	"Kit #30" in Figure 11-8
51309456-502	32 Point DI/DO Printed Circuit Assembly Replacement Kit	"Kit #31" in Figure 11-6
51404684-501	32 Point DI/DO Back Plane Replacement Kit	"Kit #32" in Figure 11-8
51404897-501	Rear terminal cover Covers all rear terminals of all instruments.	n/a
51404893-501	Mounting Adapter Plate Dimensions: mm (in) Outside 360.68 (14.2) W x 318.26 (12.53) H Covers: 322.58 (12.7) W x 280.16 (11.03) H Used to cover existing instrument cutouts for: <u>Honeywell</u> : Class 111, SpeedoMax 165/1650, SpeedoMax H, DPR180, DPR250 <u>Yokogawa</u> : Micro R 180/1800, HR 2400/2500 <u>Chessell</u> : 4180, 4250	n/a
51404893-502	Mounting Adapter Plate Dimensions: mm (in) Outside 440.69 (17.35) W x 318.26 (12.53) H Covers: 402.59 (15.85) W x 280.16 (11.03) H Used to cover existing instrument cutouts for: Honeywell: Class 112, SpeedoMax 250/2500, SpeedoMax W/L	n/a

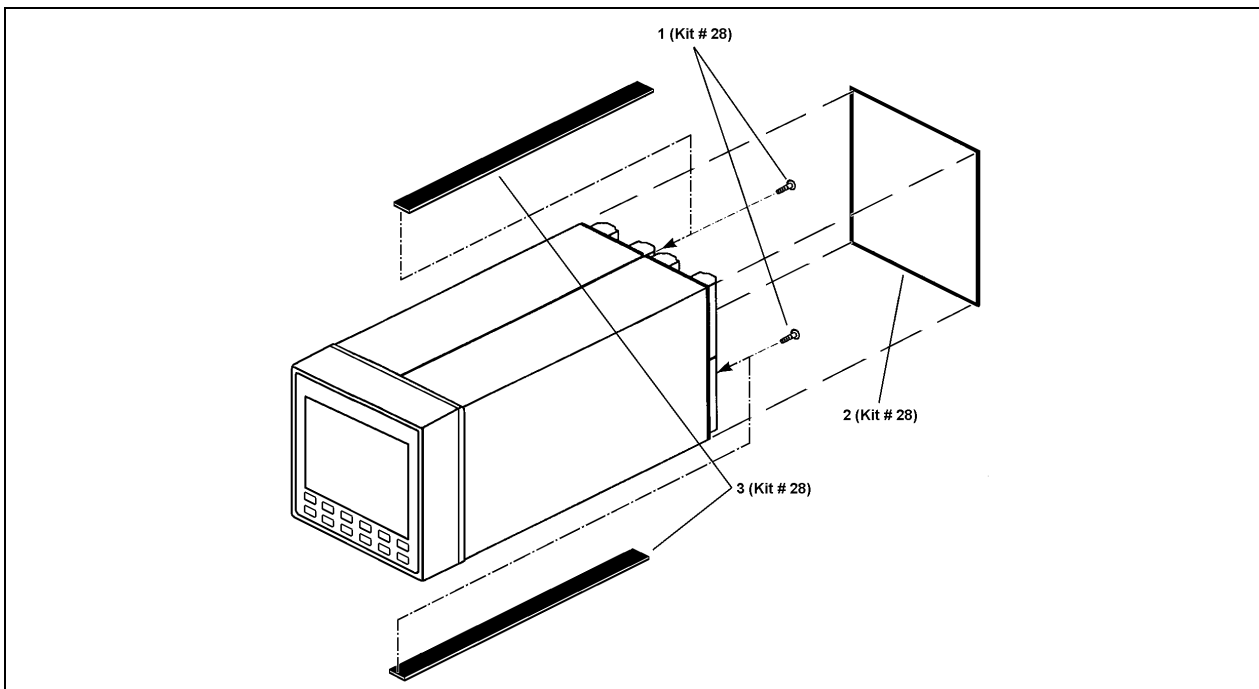


Figure 11-1 Panel Mounting Hardware Of Instrument

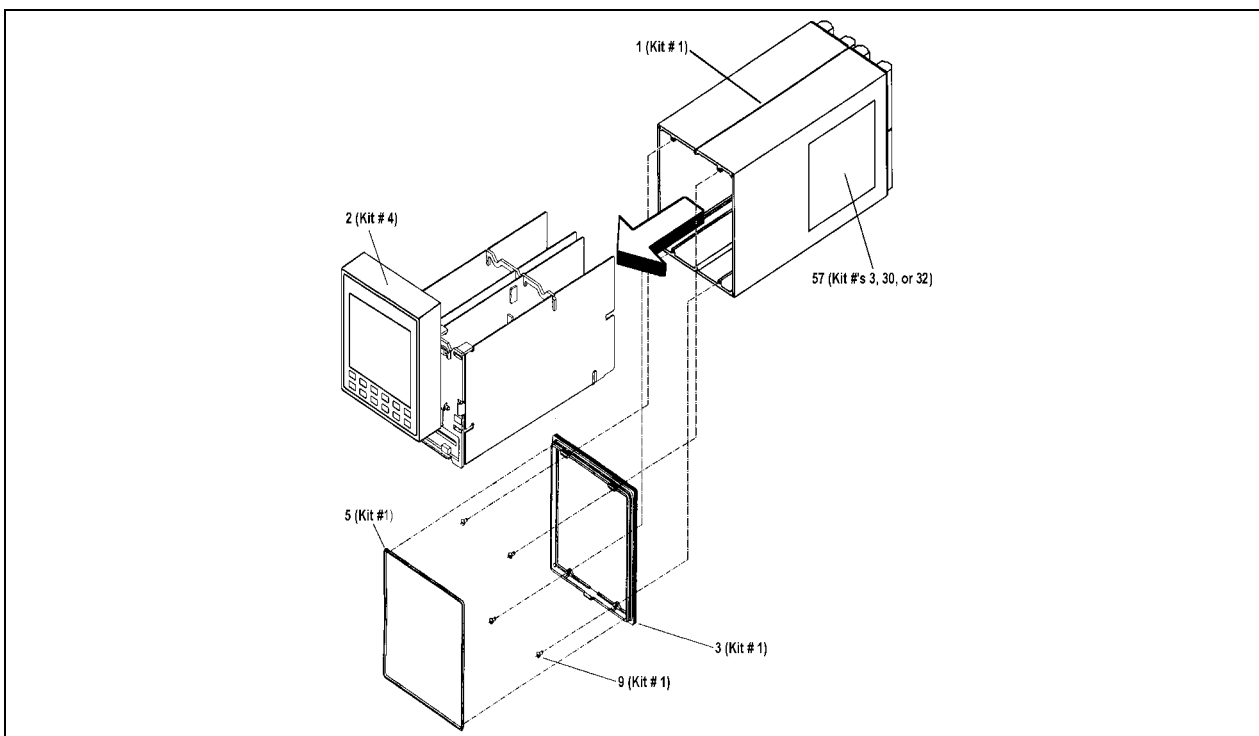


Figure 11-2 Card cage removed from case along with sub-bezel (3) and seal gasket (5)

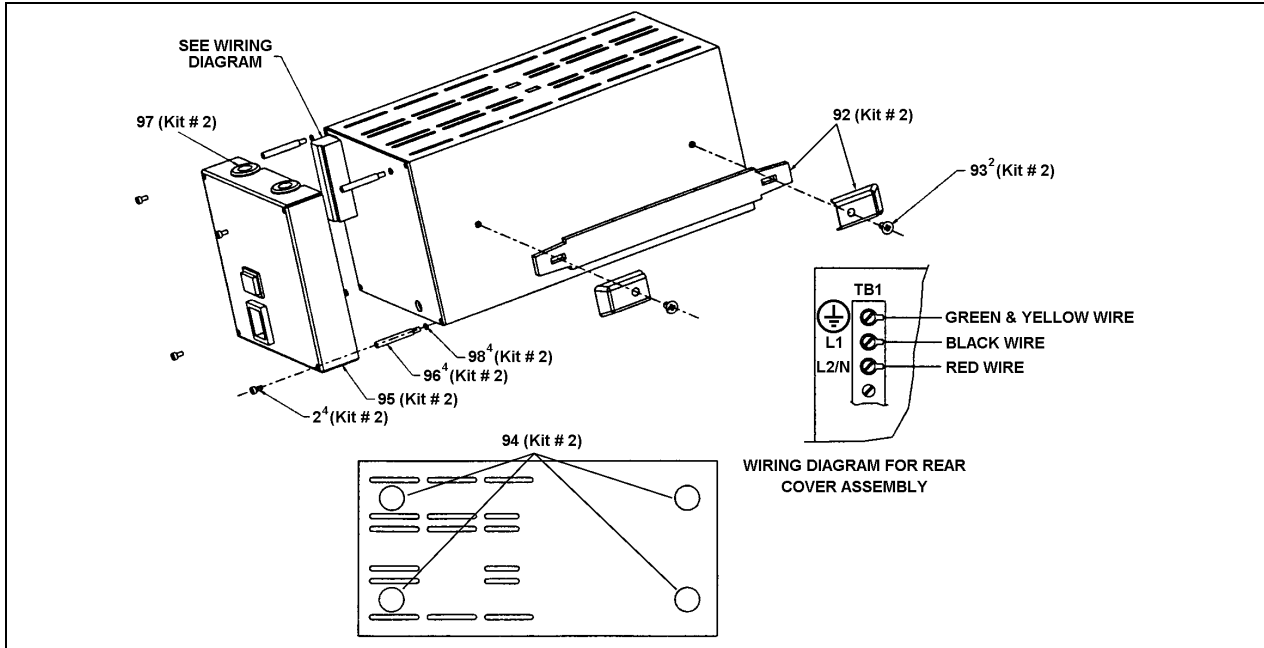


Figure 11-3 Components of portable case

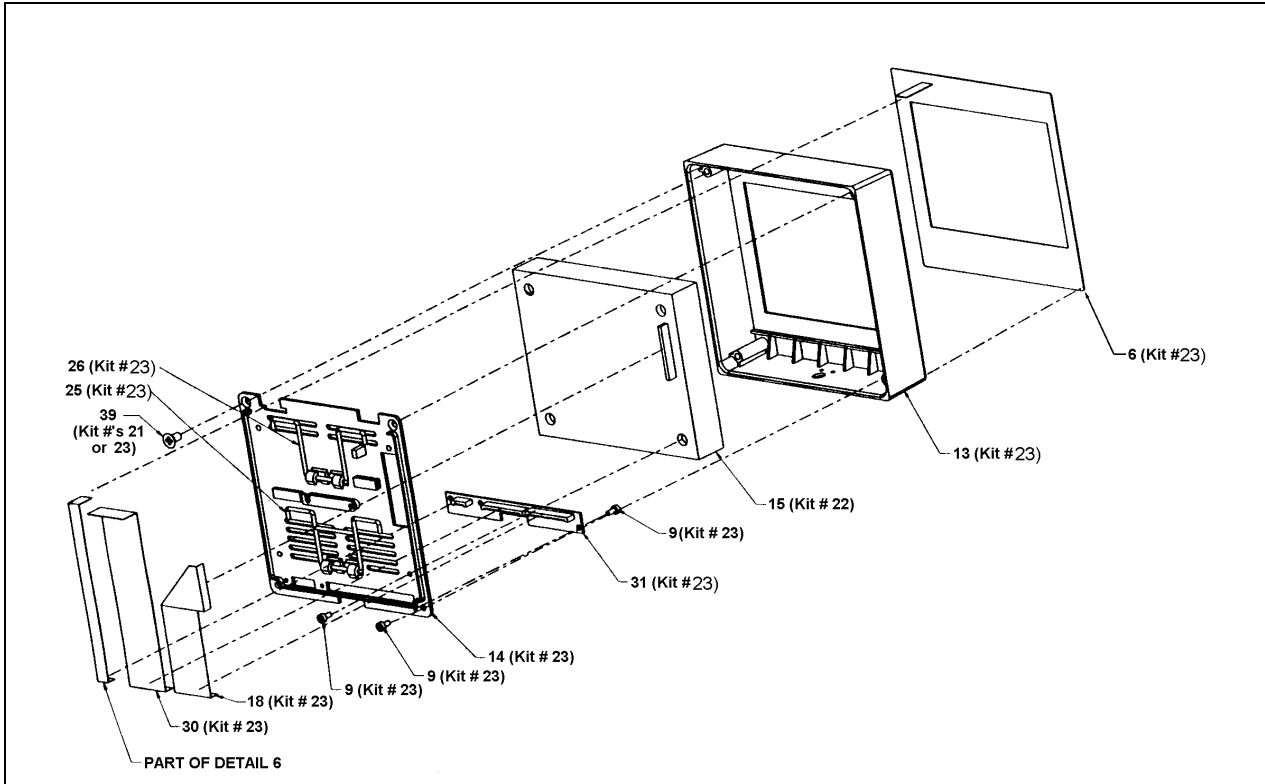


Figure 11-4 Exploded view of VPR/VRX100 display

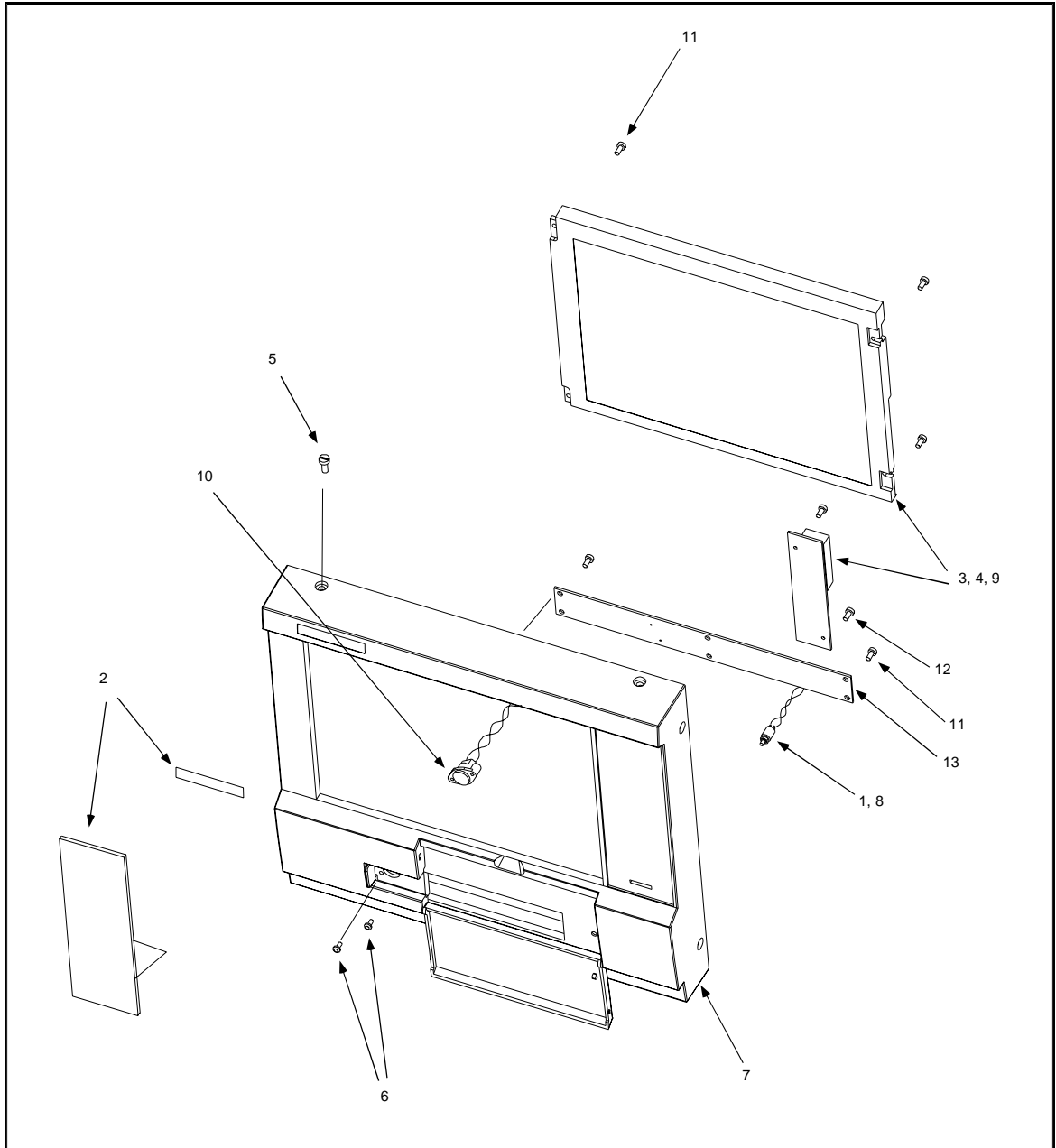


Figure 11-5 Exploded View of VRX150 Display

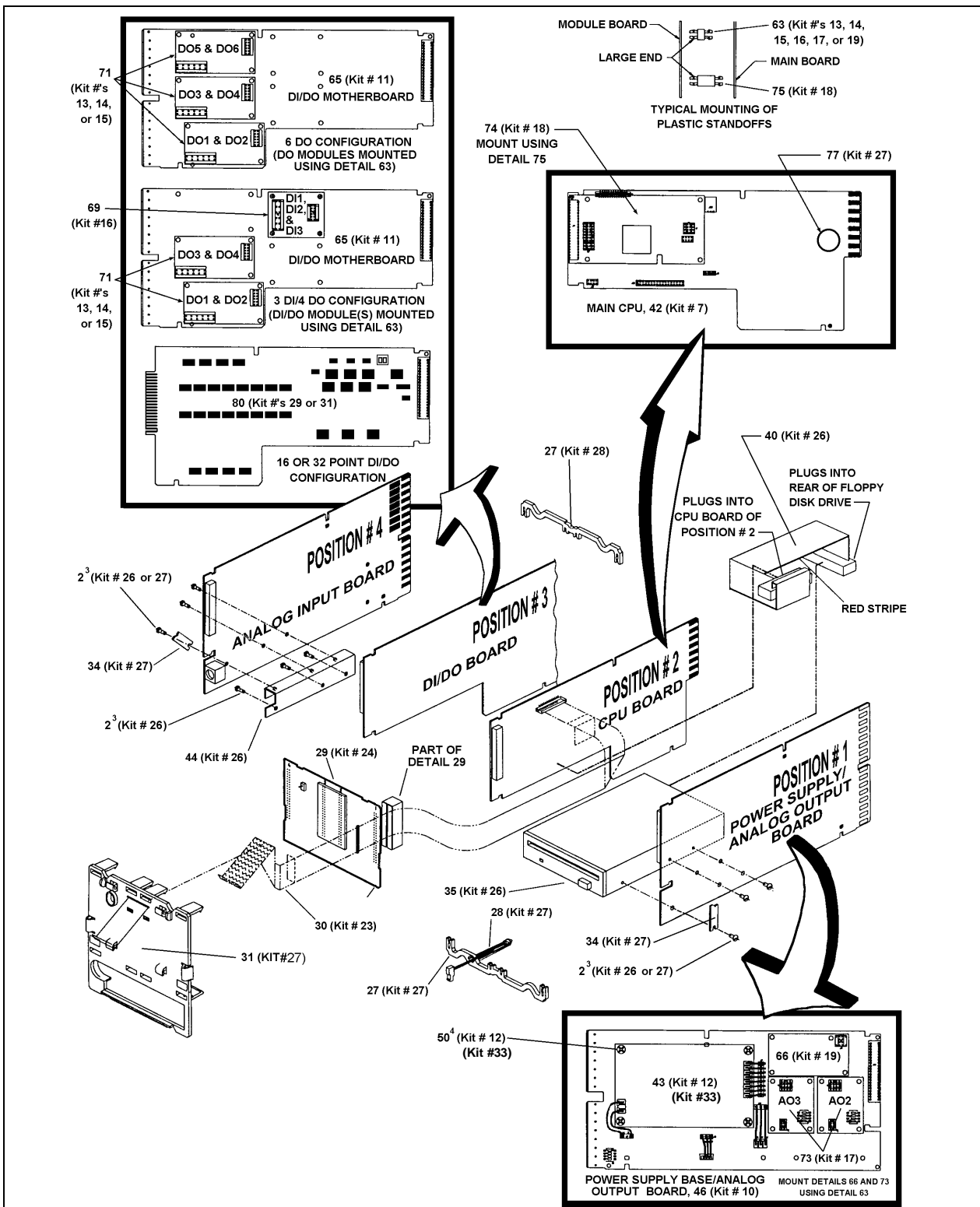


Figure 11-6 Exploded view of instrument card cage

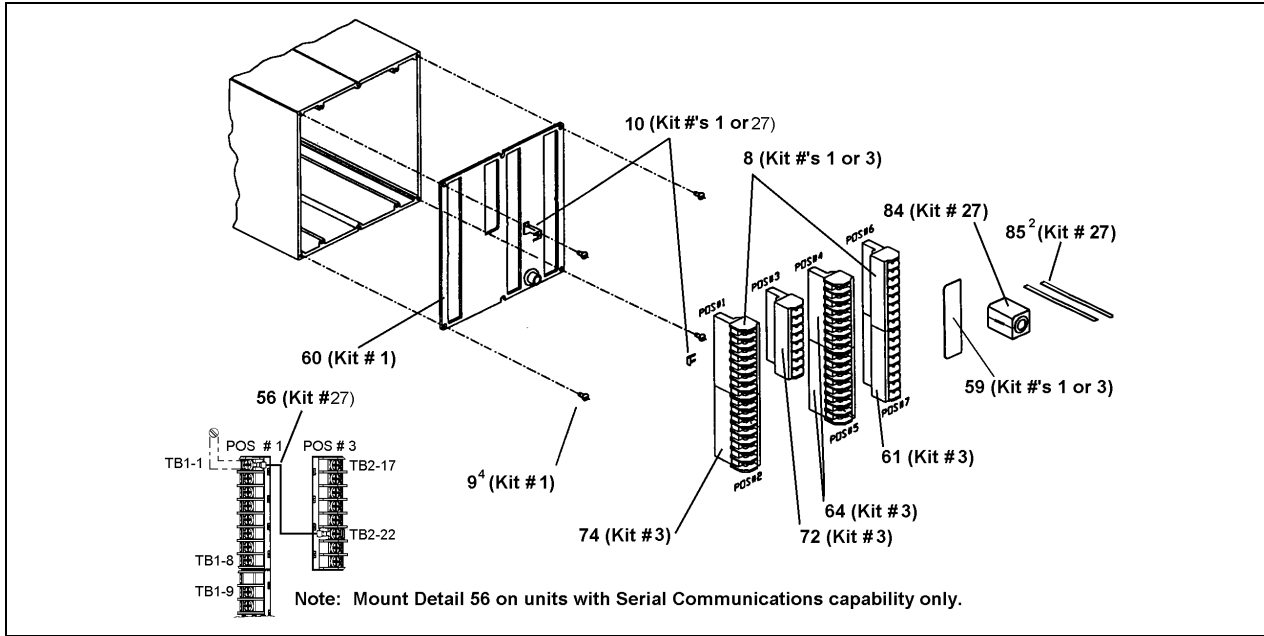


Figure 11-7 Components of case rear in units with 3 DI/4 DO or 6 DO point capability

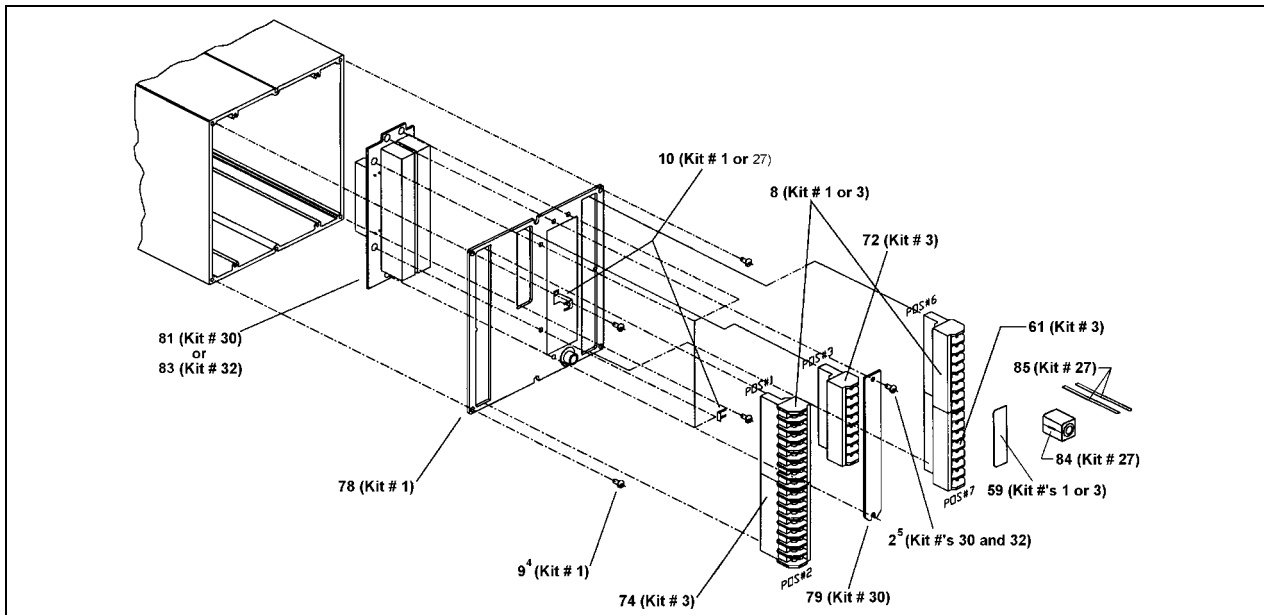


Figure 11-8 Components of case rear in units with 12 AI or 16/32 DI/DO point capability



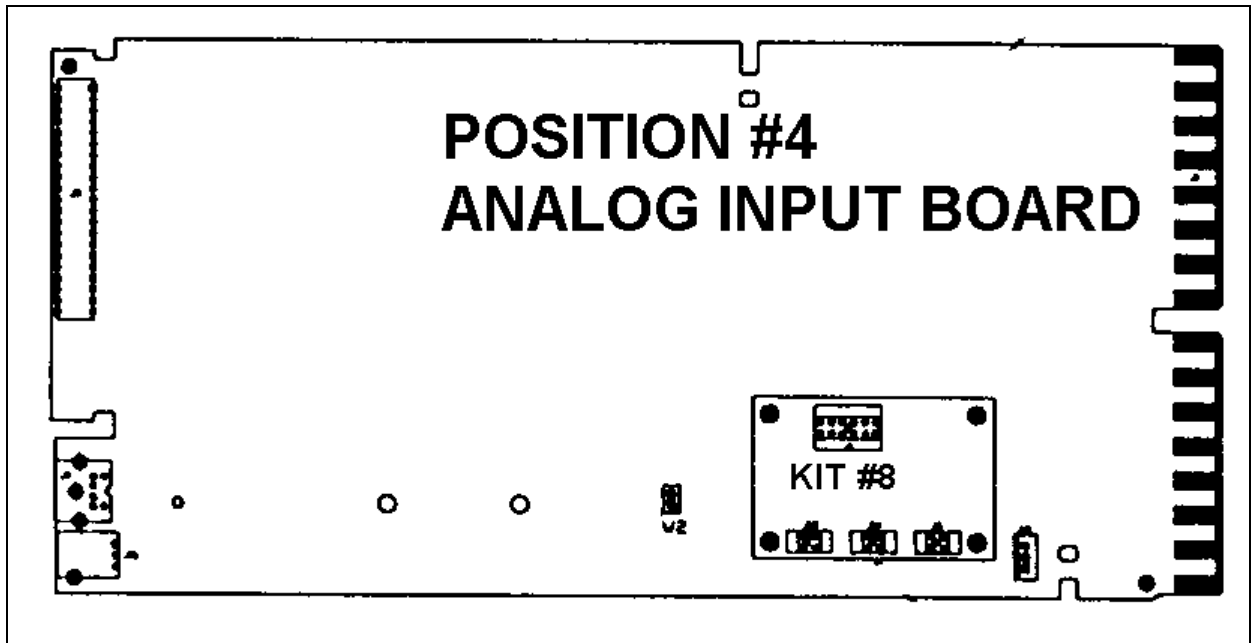


Figure 11-9 Module for Two Additional Analog Inputs



## Appendix A

### A.1 Security Bypass Procedure

#### Overview

Your instrument has a security bypass code that allows you to enter secured areas of the product. Use this bypass code if you have forgotten or lost the master and/or operator security code.

#### Bypass procedure

**Table Appendix A-1 Security Bypass Procedure**

Step	Action
1	When you are prompted for the master or operator security code, use the Increment and Decrement buttons to select the bypass code 783.
2	Press the Display button to display the forgotten master or operator code.
3	To return to the previous menu without entering the secured area, press the Menu button. To enter the secured area, press Enter.

#### ATTENTION

Remove this page for security.



## Appendix B How to Apply Digital Instrumentation in Severe Electrical Noise Environments

### B.1 Overview

#### Guideline overview

Products that incorporate digital technology provide recognized performance advantages over conventional analog instrumentation used for process control. These advantages can result in better product uniformity and greater overall efficiency when used correctly.

There are, however, certain guidelines regarding installation and wiring which must be carefully followed in order to achieve this performance. In addition to the traditional precaution of the separation of signal and power wiring in separate conduits, other measures must be taken to minimize the effects of e (EMI) and r (RFI) on the operation of the equipment. Otherwise, if high level, short duration, noise spikes are permitted to enter the digital equipment, the noise can be transferred into the system's logic networks and can be misinterpreted as signal data, resulting in erroneous system operation and other unpredictable responses.

#### What's in this appendix?

This appendix contains the following information:

Topic	See Page
Overview	293
Potential Noise Sources	294
Prevention Methods	295
Recommended Wiring Practices	296
Power Source Considerations	298
Noise Suppression at the Source	299
Ferrite Clamp Installation (CE)	303

## B.2 Potential Noise Sources

### Overview

Noise can enter electronic equipment via three methods of coupling, namely:

- Capacitive (or electrostatic)
- Inductive (or magnetic)
- Impedance.

### Capacitive and inductive coupling

Capacitive and inductive coupling have the same essential effect — they couple current or voltage, without any actual connection of the two circuits. Impedance coupling requires a connection between the two circuits. Typical noise-generating sources that could affect electronic equipment through capacitive and inductive coupling include:

- Relay coils
- Solenoids
- AC power wires — particularly at or above 100 Vac
- Current carrying cables
- Thyristor field exciters
- Radio frequency transmissions.

### Impedance-coupled noise

Impedance-coupled noise may enter by way of the lines used to power the digital equipment or by way of improper grounding. Most power lines, at typical industrial locations, are far from noise-free. The noise on them can be generated in many ways, but are nearly always associated with switching circuits of some nature.

These include:

- Large relays
- Contactors
- Motor starters
- Business and industrial machines
- Power tools
- HID (high intensity discharge) lights
- Silicon controlled rectifiers (SCRs) that are phase-angled fired.

---

## B.3 Prevention Methods

### Introduction

There are three ways to prevent electrical noise from interfering with the operation of the electronic digital equipment.

- Built-in noise rejection
- Separation of signal and power lines
- Noise suppression at source

### Built-in noise rejection

The first method is to design the digital equipment with a high degree of noise rejection built in. This includes housing the equipment in a case that will provide shielding, liberal use of noise rejection filters and opto-isolators, and the use of noise suppressors on potential noise sources within the equipment itself. This, of course, is the responsibility of the manufacturer who usually performs extensive laboratory and field testing of newly designed digital equipment to insure the adequacy of its immunity to noise. As a minimum requirement, the equipment should be able to pass the tests outlined in the IEEE Standard 472-1974 (*Surge Withstand Capacity Tests*).

### Signal and power line separation

The second method is to prevent noise from getting on the signal and power lines that are connected to the equipment. This is achieved by proper separation and shielding of those lines. In some cases, separate power lines or special power line regulation or filtering may be required for satisfactory electronic digital equipment operation. It is the responsibility of the installer to follow good wiring practices.

### Suppression at the source

The third prevention method is to suppress the noise at its source. This is the most effective but also the most difficult because it is not easy to identify all of the potential noise sources in a typical industrial installation. Therefore, "suppression" is usually a last resort for those extreme situations where the other methods are insufficient by themselves. See *Noise Suppression at Source* which follows.

## B.4 Recommended Wiring Practices

### General rules

- All wiring must conform to local codes and practices.
- Wires carrying similar types of signals (Table Appendix B-1) may be bundled together, but bundles with different types of signals must be kept separate to prevent inductive or capacitive coupling.

### CE compliance

Shielded wires are required on all Analog I/O, low-level Discrete I/O and Communications connections to meet CE compliance for emissions and immunity. Shields must be connected to the Local Earth Ground such as the ground bus bar or a grounded panel.

#### General Wiring Recommendations

All input signal wires, including thermocouples and extension lead wire, must be shielded, and the shields connected to Earth Ground. DO NOT connect shield to any other unit ground; this will not provide adequate immunity protection.

#### Noise Grounding

The shields for all cables must be connected to Earth Ground. DO NOT connect shield to any other unit ground; this will not provide adequate immunity protection.

#### Communications Wiring and Grounding

All communication wires must have a triple shield (a shield around each pair for TX and RX and an isolated overall shield). The shields for each twisted pair are to be tied together and connected to COM on the communication terminal block. The outer shield must be connected to Earth Ground. DO NOT connect shield to any other unit ground; this will not provide adequate immunity protection.

### Wire bundling

Table Appendix B-1 shows what wiring should be bundled together to prevent inductive or capacitive coupling.



Table Appendix B-1 External Wiring

Wire Function		Bundle No.	Are Shielded Twisted Wires Recommended?
No.	Type		
1 2 3	HIGH VOLTAGE Line Power Earth Ground Line Voltage Digital I/O	1	NO
4 5	ANALOG I/O Process Variable RTD Thermocouple dc Millivolts Low Level (<100V) 4-20 mA dc 1-5 Vdc	2	YES
6 7	DIGITAL I/O Low Voltage (<100V) Computer Interface	3	YES

#### Additional rules

Please observe these additional rules for wire bundling:

- For distances over five (5) feet, and when shielding is recommended, use a separate metal tray or conduit for each bundle. Where conduits or trays are not practical, use twisted wires with a metal overbraid and provide physical separation of at least one foot.
- Tray covers must be in continuous contact with the side rails of the trays.
- When unlike signal levels must cross, either in trays or conduits, they should cross at a 90-degree angle and at a maximum spacing. Where it is not possible to provide spacing, a grounded steel barrier or grid should be placed between the unlike levels at the crossover points.
- Trays containing low level wiring should have solid bottoms and sides. Tray covers must be used for complete shielding. Tray cover contact with side rails must be positive and continuous to avoid high reluctance air gaps, which impair shielding. Trays for low level cables should be metal and solidly grounded.
- Wires containing low level signals should not be routed near any of the following:
  - Contactors,
  - Motors,
  - Generators,
  - Radio transmitters, and
  - Wires carrying high current that is being switched on and off.
- Use a 12-gage (or heavier) insulated stranded wire for the ground connection. Attach it firmly to a proven good earth ground such as a metal stake driven into the ground.
- All shields should be grounded at one end only — preferably the instrument end.

## B.5 Power Source Considerations

### Operate within limits

The AC power for the digital electronic equipment must be within the voltage and frequency limits specified for that equipment. Attempts to operate outside the specified limits will result in no performance. For those installations where the supply voltage will not stay within the specified limits, a ferroresonant transformer, for voltage resolution, should be used.

### Independent AC source

For protection against noise, the AC source for the digital electronic equipment should be independent of all other loads especially when switching loads are involved. For example, it should not provide power for air-conditioning, convenience outlets, lighting, motors, or similar noise-generating devices. To obtain e(see Figure Appendix B-1) a separate transformer is required to supply power to the digital equipment. For additional noise and transient rejection, shielded primary and secondary windings may be required. And, if necessary, power line filters may be added to attenuate noise signals that have a higher frequency than the power line frequency.

### Transformer for digital equipment

Figure Appendix B-1 is an illustration of a separate transformer required to supply power to digital equipment.

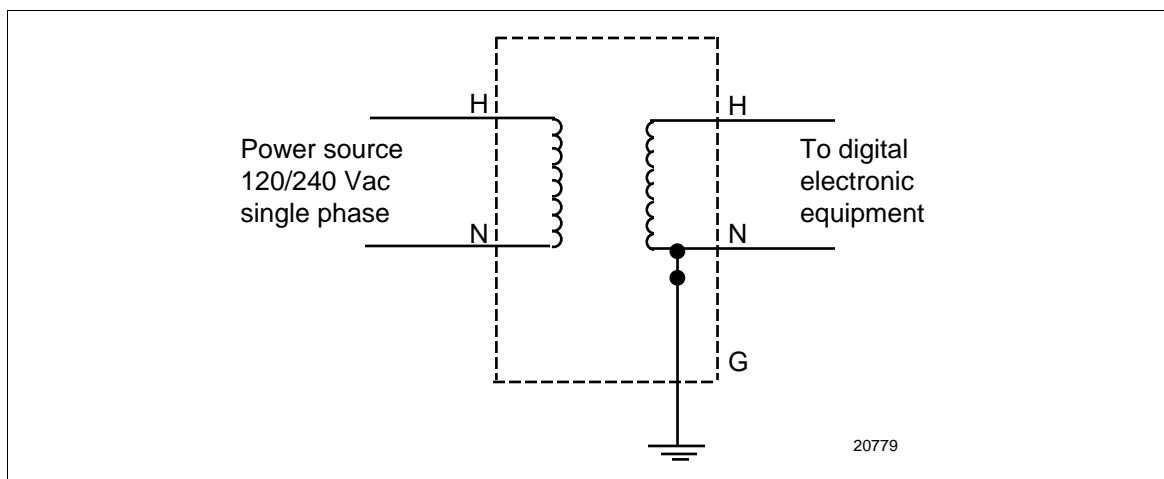


Figure Appendix B-1 Transformer for Digital Equipment

## B.6 Noise Suppression at the Source

### Introduction

Generally speaking, when good wiring practices are used with well- designed digital electronic equipment, no further noise protection is necessary. However, in some severe electrical environments, the magnitude of the electrical noise is so great that it must be suppressed at the source. In most control cabinets, the main sources of noise are motor starters, contactors, relays, and switching gear. For this reason, many manufacturers of these devices supply "surge suppressors" which mount directly on the noise source (for example, on the coil of a control relay or motor starter).

For those devices that do not have accessory "surge suppressors," resistance-capacitance (RC) circuits and/or voltage limiters such as metal varistors may be added when and where needed. This can be broken down into two categories, namely inductive loads (for example, a relay switch in series with a relay coil) and contacts.

### Inductive coils

Metal Oxide Varistors (MOVs) are recommended for transient suppression in inductive coils. An MOV is connected in parallel with the coil and is as close as physically possible to the coil (see Figure Appendix B-2). MOV devices (listed in Table Appendix B-2) are recommended for general purpose applications.

Table Appendix B-2 lists part numbers for recommended MOV devices.

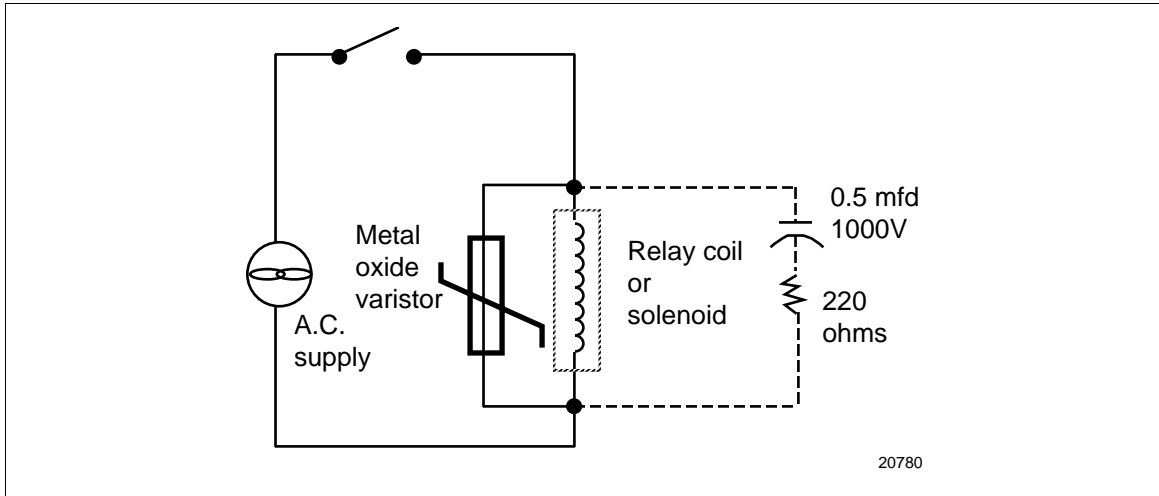
**Table Appendix B-2 MOV Devices**

Part Number	30732481-501	30732481-502
Maximum AC	130V	275V
Energy Pulse Rating	10 Joules	15 Joules
Supplier (General Electric)	V130LA10A	V275LA15A

*Continued on next page*

**Inductive coils, continued**

Figure Appendix B-2 is an illustration of transient suppression in inductive coils.



**Figure Appendix B-2 Transient Suppression in Inductive Coils**

Additional protection may be provided by adding an RC circuit in parallel with the MOV. This consists of a 220-ohm resistor in series with a 0.5 microfarad, 1000V capacitor. The power rating of the resistor will depend on the voltage rating of the coil (see Table Appendix B-3).

**Table Appendix B-3 Coil Voltage vs. Resistor Voltage Rating**

Coil Voltage	Resistor Voltage Rating
115V	1/4 Watt
230V	1 Watt
460V	3 Watt
550V	5 Watt

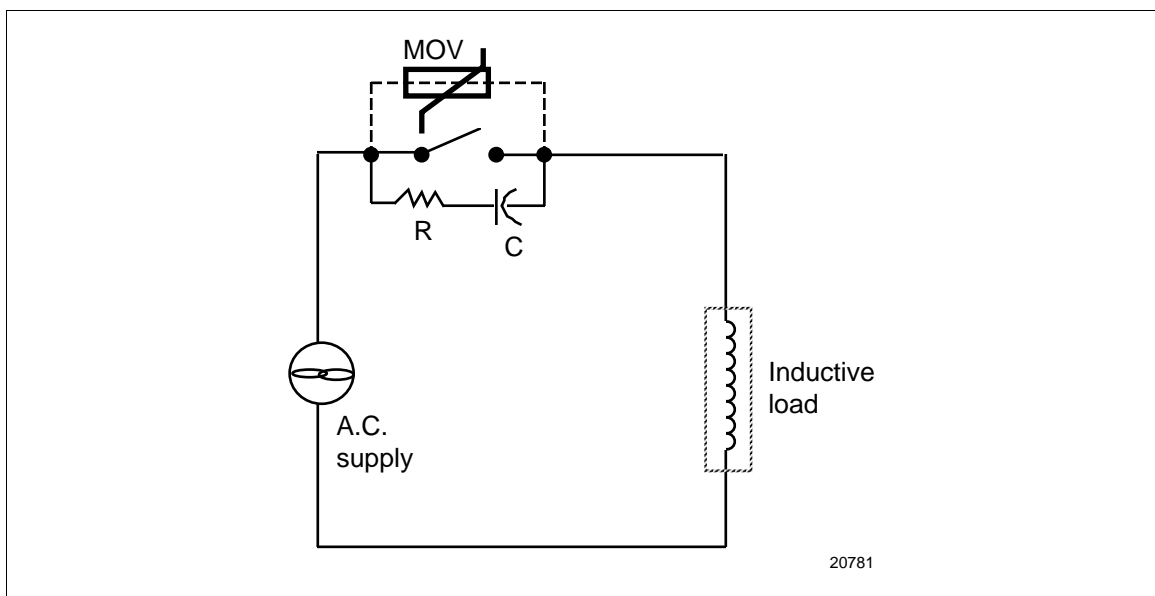
*Continued on next page*

## Contacts

When a contact interrupts an inductive load, a certain amount of energy is stored in the load. An MOV or RC circuit in parallel with the load provides a place where this energy may be dissipated. However, if there is no MOV or RC circuit, the energy may create a visible electrical arc across the open contacts. This, in turn, results in electrical noise as well as damage to the contacts.

One way to eliminate this arc is to connect a resistor and capacitor across the contacts (see Figure Appendix B-3). A combination of 47 ohms and 0.1 microfarads (1000 Vdc) is recommended for circuits up to 3 amps and 300 Vac. For voltages above 2000 Vac, an MOV across the contact may be added for extra protection.

Figure Appendix B-3 is an illustration of a resistor and capacitor connected across a contact to eliminate electrical noise.



**Figure Appendix B-3 Contact Noise Suppression**

For large load currents, a rule of thumb is to size the capacitor so that the number of microfarads equals the number of amperes in the load current, and the resistor has the same resistance value as the load. The objective is to eliminate the visible arc.

Either discrete resistors and capacitors or packaged RC networks may be used. An RC network (47 ohms and 0.1 microfarad) is available from Honeywell as part number 30371852-001. Similar RC networks are available from Electrocube Inc. (part number RG1782-3) and from Industrial Condenser Corporation.

*Continued on next page*

In DC circuits, the power dissipation under steady state condition can be eliminated by placing a diode (in series with a resistor) in parallel with the load (see Figure Appendix B-4). The value of R should be less than or equal to the DC resistance of the inductive load.

Figure Appendix B-4 is an illustration of DC load noise suppression.

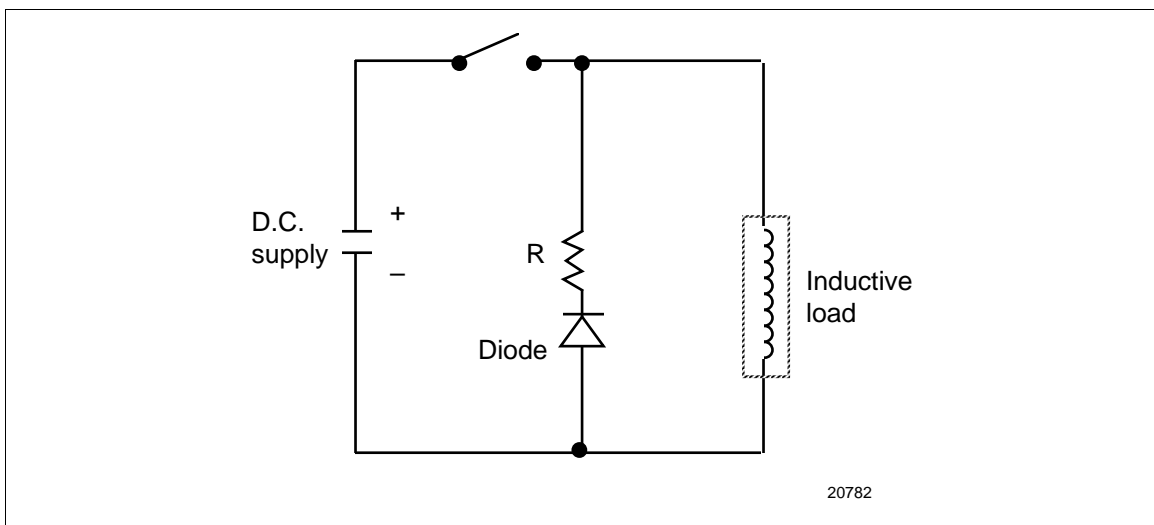


Figure Appendix B-4 DC Load Noise Suppression

## B.7 Ferrite Clamp Installation Procedure

### Purpose

This procedure ensures that unwanted radio frequency noise is filtered, which is required for CE compliance.

### Parts needed

Part #	Quantity	Description
047260	2	Ferrite cable clamps
089037	4	Nylon cable ties

### Procedure

Step	Action
1	Disconnect all power to the instrument.
2	Allow 3" to 4" of extra slack in the wires.
3	Group all analog input wires together.
4	Open the ferrite cable clamp by gently prying up on the clasp located on the side of the clamp.
5	With the clamp approximately 3/4" to 1" from the instrument's terminals, lay the analog input wires in the groove of the clamp.
6	Snap the clamp closed, making sure to not pinch the wires.
7	Secure the wires by affixing a cable tie around the wires near each end of the clamp.
8	Trim the cable tie but leave a "tail" of approximately 1".
9	Repeat steps 1-8 for the analog output wires.

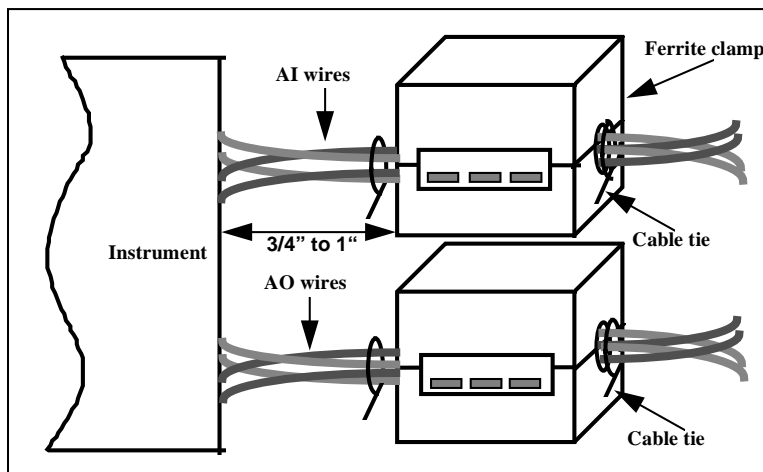


Figure Appendix B-5 Ferrite Clamp Installation





**A**

Action State, 104, 105  
 advancing profile, 215  
 Alarm  
   acknowledging, 241  
   Action, 144  
   Compare Point (deviation), 144  
   Deviation, 144  
   edit setpoints, 244  
   High, 144  
   High Rate, 144  
   history, 241  
   Hysteresis, 145  
   Low, 144  
   Low Rate, 144  
   program, 144  
   summary, 240  
   what happens during, 241  
 Alarm History, 241  
 Analog Input Adjust, 244  
 Analog Input Connections, 25  
 analog inputs  
   changing to expanded range, 266  
   program, 85  
 Analog output  
   adjusting, 245  
 Analog Output Connections, 26  
 analog outputs  
   program, 100  
 analog point values  
   displaying, 242  
 Analog Switch, 108  
 Approach High and Low, 93  
 Assign Displays to Keys, 161  
 Auto-Manual Select, 93

**B**

Back Calculation, 136  
 Back Calculation Value, 94  
 Back-Calculation, 89  
 Batch Control, 179  
 buffer capacity, 178  
 Bumpless Transfer, 93  
 Button functions, 39  
 Byte order, 165

**C**

Calculated Value  
   Advanced Splitter Output, 134  
   BCD, 122  
   CEMS Block Average, 142  
   CEMS Rolling Average, 143  
   Compare, 109  
   Counter, 113

Free Form Logic, 119  
 Free Form Math, 115  
 Function Generator, 124  
 Interval Timer, 126  
 Inverter, 121  
 Logic, 117  
 Mass Flow with Square Root, 129  
 Math, 114  
 Multiple Average, 141  
 Peak Picking, 107  
 Periodic Timer, 127  
 Relative Humidity, 132  
 Scaling, 137  
 Signal Clamp, 138  
 Signal Select, 108  
 Single Point Block Average, 139  
 Single Point Rolling Average, 140  
 Standard Splitter Output, 136  
 Sterilization, 133  
 calculated values  
   program, 106  
 Calculated Values, 89  
 Calibrate  
   Analog Outputs, 258  
   EMF Inputs, 257  
 Calibrating RTD Inputs, 258  
 CAT, 89, 100, 101  
 CAT Calibration, 258  
 CAT/VAT  
   changing switch settings, 267  
 circuit card  
   replacement, 265  
 clock  
   set, 166  
 Cold Start, 261  
 comm link  
   setting termination jumper, 270  
 Communications, 29  
   Byte order, 165  
   Update value from remote host, 149  
 communications, serial  
   program, 165  
 Constant  
   Destination, 150  
   edit, 244  
   Program, 149  
 Control loop  
   errors, 275  
   pretune, 250  
   tuning, 247  
 Control Loop Programming Structure, 89  
 control loops  
   program, 89  
 Copy Block, 151  
 Custom algorithm prompts, 88

**D**

DAT, 89, 100  
 Data Entry, 244  
 Data Entry From External Sources, 44  
 Data Storage, 234  
   Allocate Storage, 177  
   Batch Control, 179  
   current storage setup, 236  
   Enable storage, 170  
   examine replaying data. *See* Trend, interacting  
   Initialization errors, 236  
   Initializing Disk, 181, 235  
   installing DSU, 15  
   messages. *See* Messages  
   overview, 73  
   preinitialize 120MB/Zip disk with DSU, 180  
   replaying, 239  
   *Set Up Alarms*, 174  
   *Set Up Diagnostics*, 175  
   Set Up Disk Capacity, 177  
   *Set Up Events*, 174  
   Set Up New Schedules, 171  
   Set Up Trend Capacity, 177  
   *Set Up Trend Data 1*, 171  
   *Set Up Trend Data 2 & 3*, 174  
   *Set Up Unit Data*, 175  
   Setup, 170  
   starting and stopping, 237  
   status, 238  
   typical tasks, 234  
   Warning level %, 179  
 Database Services, 260  
 Deadband, 136  
 Delete All Diagnostics, 243  
 Demo, 262  
 Diagnostic  
   acknowledging, 242  
   deleting all, 243  
   what happens during, 242  
 Diagnostic messages, 271  
 DIAT, 103  
 DIAT output  
   programming, 103  
 discrete  
   forcing, 244  
 Discrete Input Connections, 26  
 discrete inputs  
   program, 104  
 Discrete Output Connections, 27  
 discrete outputs  
   program, 105  
 discrete point status  
   displaying, 242  
 Disk  
   Formatting, 179  
   intialize for data storage, 235  
 Disk capacity for data storage, 177  
 Display alarm summary, 240  
 Display All Analogs, 242  
 Display All Discretes, 242

Display button  
   displays accessed by, 219  
 Display Messages and Symbols, 229  
 Displays  
   Program, 152  
 DSU, 15  
   installing, 15  
   unpacking, 4  
   using, 180

**E**

Edit Alarm Setpoints, 244  
 Edit Constants, 244  
 editing profile segments, 218  
 Electrical Units, 86, 88  
 Enable Features, 163  
 Enter Labels, 82  
 error messages, 271  
 Error Messages, 277  
 Events  
   middle of ramp segment, 192  
 exponential notation  
   how to display, 80

**F**

Feedback, 136  
 First Good, 108  
 First Time Start, 261  
 floppy disk  
   initializing, 235  
   installing, 234  
   remove or install, 46  
 Floppy drive  
   VRX150 access, 47  
 Force DI/DO Points, 244  
 Format Disk, 179  
 Frequency, 260  
 Frequently used programming parameters, 80  
 Front access, 46  
 function block  
   interconnecting, 54  
   parameter code format, 55  
   programming a function block parameter, 57  
   programming input parameters, 54  
 Function block  
   components, 50  
   defined, 48  
   Function block parameter, 51  
   Input parameter, 50  
   Parameter code, 51  
   Parameter code designators, 52

**G**

General Wiring Recommendations, 24

**H**

Hold, 87, 88  
 holding profile, 214  
 How data is stored, 235  
 How To Program Function Blocks and Features, 77

**I**

Impulse Time, 101  
 Initialization errors, 236  
 Initializing Disk, 181  
 Initializing disk for data storage, 235  
 Installation, 15  
 Interacting With Primary Displays, 221

**K**

keyboard  
   how to connect, 46  
 Keyboard connector  
   VRX150 access, 47

**L**

labels, 82  
 Lag Time Constant, 88  
 language  
   select, 169  
 load program, 212  
 Location, 16  
 logarithmic display, 156  
 loop  
   changing between Auto & Manual modes, 227  
   changing output, 228  
   changing setpoint value, 228  
   changing tuning parameters, 228  
 Loop Characteristics, 89  
 Loop displays  
   interacting with, 227  
 Loop error indicators, 275  
 Loop Menu Items, 93

**M**

Mains Frequency, 260  
 Maintenance, 255  
 Maintenance mode  
   defined, 31  
 Math  
   Operator, 114  
 messages, 229  
 Messages  
   location, 229  
 Messages and Symbols, description, 230  
 Minimum On and Off Time, 102  
 Modes of operation, 31  
 mounting  
   seismic, 17  
 Mounting, 16

Mounting adjacent instruments, 17

**N**

Network, 29  
 Noise Suppression, 24  
 Number  
   how to enter, 55

**O**

Off-line Diagnostics, 259  
 Online mode  
   defined, 31  
 Online Operation Using Menus, 233  
 Online Operations Using Primary Displays, 219  
 Online summaries  
   accessing, 240  
 On-Site Adjustments, 263  
 operating mode  
   setting, 234

**P**

Panel display  
   interacting with, 225, 226  
 Parts, 281  
 Power Connections, 24  
 PP type output, 103  
 Preset Output Value, 147  
 Pretune  
   Abort messages, 253  
   COMPLETE menu, 252  
   IDENTIFYING & CALCULATING menus, 251  
   STOPPED menu, 250  
 Pretune Loop, 250  
 primary display, example, 229  
 Process Variable, 89  
 Product Information, 243  
 Product Information, 260  
 profile  
   advance, 196  
   auto cycle, 205  
   defined, 183  
   event, 192  
   fast forward, 197  
   guaranteed soak, 191  
   Hold, 196  
   hold multiple profilers simultaneously, 194  
   hot start, 196  
   jump, 205  
   loop, 193  
   multi phase, defined, 185  
   process variables, 186  
   ramp types, 186  
   reset/run, 195  
   shutdown, 198  
   single phase, defined, 185  
   start, 195  
   synchronize multiple profilers, 194

- time multiplier, 206
- Profile
  - running 2 or more at once, 151
  - start by pressing a key, 51
- program
  - defined, 183
- Program Analog Inputs, 85
- Program Analog Outputs, 100
- Program Calculated Values, 106
- Program Control Loops, 89
- Program Discrete Inputs, 104
- Program Discrete Outputs, 105
- Program mode
  - defined, 31
- Program mode menu, 79
- Program Security, 164
- Programming and Operating Concepts and Procedures, 31
- Programming Procedure, 90
- Programming tips, 78
- Proportional Band, 95

## **R**

- Removing the Circuit Card Assembly, 263
- Replaying stored data, 239
- RESET, 126
- Reset Input, 107
- Reset Unit, 260
- resetting profile, 214
- review programming, 254
- Routine Maintenance, 257

## **S**

- Safety Grounding, 24
- Scan Rate, 168
- security
  - program, 164
- Select Language, 169
- Serial Communications, 165
- Set Clock, 166
- Set Mode, 81
- Set Up Bar Graph 1, 159
- Set Up Bar Graph 2, 159
- Set Up Panel Display, 159
- Set Up Unit Data Display, 159
- setpoint
  - adjust, 247
  - toggle, 247
- Setpoint Trend Display
  - interacting with, 221
- shutting down profile, 215

- Site Preparation, 15
- Software Version Number, 260
- Split Output Loop, 89, 90
- Standard algorithm prompts, 85
- starting profile, 213

## **T**

- totalizer
  - reset by pressing a key, 51
- Totalizer
  - program, 146
- Totalizer Reset, 245
- trend
  - display logarithmically, 156
- Trend
  - changing timebase, 224
  - detail, 223
  - find, 223
  - hold, 223
  - new file, 224
  - scroll, 223
  - Selecting Profiles to be displayed, 160
  - Set Up Trend 1, 155
  - Set Up Trend 2, 159
  - zoom, 223
- Trend, interacting with, 222

## **U**

- unpacking
  - DSU, 4
- Unpacking, 4
- Update value from remote host, 149
- upgrade, 260

## **V**

- VAT, 89, 100
- VAT Calibration, 258
- viewing profile details, 216
- viewing profile events, 216
- viewing profile summary, 217

## **W**

- Warm Start, 261
- Warm Start Time, 261
- Warning level %
  - data storage, 179
- Wiring, 20



For at undgå elektrisk stød med mulighed for personskade, skal alle sikkerhedsbestemmelser i denne manual følges nøje.



Dette symbol advarer brugeren om en potentiel berøringsfare, såfremt der kan være adgang til den livsfarlige netspænding.



Beskyttende jordterminal. Terminalen er forberedt for og skal forbindes til beskyttelsesjordledning i henhold til stærkstrømsberkendtgørelsen (DK).

- Hvis udstyret ikke bruges som specificeret i manualen, kan den beskyttelse udstyret yder blive nedsat eller forsvinde.
- Eerstat kun komponenter som udtrykkeligt er specificeret som udskiftelige i manualen.
- Alle ledningsforbindelser skal følge stærkstrømsberkendtgørelsen (DK) og udføres af autoriseret erfarent personel.
- Den beskyttende jordterminal skal forbindes først af alle forbindelser (og fjernes som den sidste).
- Det anbefales jvf. stærkstrømsberkendtgørelsen, at der installeres en afbryder til frosyningsspændingen nær udstyret.

### **UDSTYRS SPECIFIKATIONER**

Strømforsyning	85 til 265 V AC/DC
Frekvens	50 – 60 Hz
Nominel effekt	45 VA
Sikringsværdi	2 A / 250 V AC/DC

### **OMGIVELSE SPECIFIKATIONER**

Placer ikke udstyret i nærheden af brandbare væsker eller dampe.

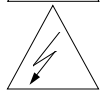
Temperatur	Rumtemperatur : 0 til 50°C Opbevaring : -20 til 70°C
Fugtighed	10 til 90% RH ikke kondenserende / 40°C
Vibration	5 til 15 Hz, amplitude 1 mm 15 to 150 Hz, acceleration 0.5 g

### **UDSTYRS INSTALLATION**

Skriveren skal monteres i en tavle for at forhindre adgang til bagterminaler.



Ter vermindering van het gevaar van elektrische schokken die lichamelijk letsel kunnen veroorzaken, dient u alle veiligheidsaanwijzingen in dit dokument te volgen.



Dit symbool waarschuwt de gebruiker voor een potentieel schokgevaar wanneer toegang bestaat tot onderdelen die onder gevaarlijke spanning staan.



Beschermende aarde-aansluiting. Bestemd voor aansluiting van de aardingsdraad van de voeding.

- Indien de apparatuur wordt gebruikt anders dan door de fabrikant gespecificeerd, kan de bescherming, die de apparatuur biedt ongedaan worden gemaakt.
- Alleen die onderdelen mogen worden vervangen die door de fabrikant als uitwisselbaar zijn aangemerkt.
- Alle bedrading moet in overeenstemming zijn met de lokale elektriciteiseisen en moet aangelegd worden door geautoriseerd, ervaren personeel.
- De aardingsdraad moet worden aangesloten vóórdat alle andere bedrading wordt aangesloten (en als laatste worden verbroken).
- Het verdient aanbeveling een netschakelaar aan te brengen vlakbij het instrument.

### **APPARATUUR VOORWAARDEN**

Voedingsspanning	85 tot 265 V AC/DC
Frequentie	50 – 60 Hz
Vermogen of stroomvermogen	45 VA
Zekering	2.0 A / 250 V AC/DC

### **OMGEVINGSCONDITIONS**

Gebruik het instrument niet in de aanwezigheid van ontvlambare vloeistoffen of dampen. Het gebruik van elk elektrisch instrument in een dergelijke omgeving vormt een gevaar voor uw veiligheid.

Temperatuur	In bedrijf : 0 tot 50°C Opslag : -20 tot 70°C
Vochtigheid	10 tot 90% RH niet condenserend / 40°C
Trilling	5 tot 15 Hz, amplitude 1 mm 15 tot 150 Hz, versnelling 0,5 g

### **MONTAGE VAN DE APPARATUUR**

De recorder moet worden gemonteerd in een paneel om de toegankelijkheid tot de achterste aansluitpunten te beperken.



Noudata tämän ohjeen kaikkia turvaohjeita välttääksesi sähkötapaturman vaaraa.



Tämä merkki varoittaa käyttäjää sähköiskun vaarasta paikassa, missä voi koskettaa vaarallisia jännitteitä.



Suojamaaliitin. Kytke maadoitsjohdin tähän liittimeen.

- Jos laitetta käytetään olosuhteissa, joihin sitä ei ole suunniteltu, käyttöturvallisuus voi heikentyä.
- Älä vaihda mitään komponenttia tai osaa, jota valmistaja ei ole määritellyt käyttäjän vaihdettavaksi.
- Asennus ja johdotus on tehtävä paikallisten varmuusmääräysten mukaisesti valtuutetun sähköasentajan toimesta.
- Ensimmäiseksi on kytkettävä suojamaa-liitin (ja viimeiseksi irroittettava).
- Laitteen läheisyyteen suositellaan asennettavaksi verkkokytkin.

### **LAITTEEN VAATIMUKSET**

Syöttöjännite	85 - 265 V AC/DC
Taajuus	50 – 60 Hz
Teho	45 VA
Sulakearvo	2 A / 250 V AC/DC

### **KÄYTTÖOLOSUHTEET**

Älä käytä laitetta paikassa jossa on syttyviä nesteitä tai kaasuja, koska laitteen käyttö aiheuttaa räjähdysvaaran.

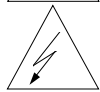
Lämpötila	ympäröivä : 0 ... 50°C Varastossa : -20 ... 70°C
Kosteus	10 ... 90% RH non condensing / 40°C
Tärinä	5 ... 15 Hz, amplitude 1 mm 15 ... 150 Hz, Kiihtyvyyys 0,5 g

### **LAITTEEN ASENNUS**

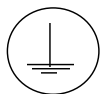
Piirturi on asennettava paneeliin siten, että peräliitimille jää riittävästi tilaa.



Pour réduire tout risque de décharge électrique qui pourrait provoquer une lésion corporelle, respectez toutes les consignes de sécurité de cette documentation.



Ce symbole avertit l'utilisateur d'un risque électrique potentiel lorsqu'il peut avoir accès à des éléments sous tension.



Borne de mise à la terre. Destinée au raccordement du conducteur de mise à la terre de l'alimentation.

- Si l'équipement est utilisé dans un but non spécifié par le constructeur, la protection fournie avec cet équipement peut être affectée.
- Aucun composant (ou pièce) ne doit être remplacé s'il n'est pas explicitement spécifié comme tel par le constructeur.
- Tous les câblages doivent être conformes aux normes locales et doivent être réalisés par un personnel autorisé et expérimenté.
- La borne de masse doit être raccordée avant tout autre câblage (et débranchée en dernier).
- Il est obligatoire de connecter cet appareil sur une ligne possédant un moyen de coupure près de l'appareil.

### **CARACTERISTIQUES DE L'EQUIPEMENT**

Tension d'alimentation	85 à 265 Vca/cc
Fréquence	50 – 60 Hz
Puissance ou courant	45 VA
Fusible	2 A / 250 Vca/cc

### **CONDITIONS AMBIANTES**

Ne jamais utiliser cet équipement en présence de liquides ou vapeurs inflammables.

L'utilisation de tout instrument électrique dans un tel environnement pourrait présenter un risque pour la sécurité.

Température	Ambiante : 0 à 50°C
	Stockage : -20 à 70°C
Humidité	10 à 90 % HR non-condensé à 40°C
Vibration	5 à 15 Hz, amplitude 1 mm
	15 à 150 Hz, accélération 0,5 g

### **INSTALLATION DE L'EQUIPEMENT**

Cet appareil doit être monté dans un panneau pour limiter l'accès aux bornes arrières par l'opérateur.





Befolgen Sie alle Sicherheitshinweise in diesen Unterlagen, um das Risiko eines Stromschlags zu verringern, der zu Körperverletzung führen kann.



Dieses Symbol warnt den Benutzer vor eventueller Berühungsgefahr, wo lebensgefährliche Spannungen zugänglich sein können.



Schützende Erdung. Für den Anschluß der schützenden Erdung der Versorgungssystemleitung.

- Bei Benutzung der Ausrüstungen auf nicht vom Hersteller angegebene Art und Weise kann der von der Ausrüstung gewährleistete Schutz beeinträchtigt werden.
- Ersetzen Sie keine Komponente (oder Teil), die/das nicht ausdrücklich vom Lieferanten als ersetzbar angegeben ist.
- Die gesamte Verkabelung muß den örtlichen Normen entsprechen und von zugelassenem, erfahrenem Personal durchgeführt werden.
- Die Erde muß vor allen anderen Kabeln angeschlossen (und zuletzt abgeklemmt) werden.
- In der Nähe der Ausrüstung muß ein Schalter in der Hauptstromversorgung vorhanden sein.

### **AUSRÜSTUNGSDATEN**

Netzspannung	85 bis 265 VAC
Frequenz	50 – 60 Hz
Nennleistung	45 VA
Sicherungswert	2 A / 250 VAC

### **UMGEBUNGSBEDINGUNGEN**

Betreiben Sie das Gerät nicht in Gegenwart entflammbarer Flüssigkeiten oder Dämpfe. Der Betrieb elektrischer Geräte in solchen Umgebungen stellt ein Sicherheitsrisiko dar.

Temperatur	Umgebung : 0 bis 50°C Lager : -20 bis 70°C
Feuchtigkeit	10 bis 90% RH ohne Kondensation / 40°C
Vibration	5 bis 15 Hz, Amplitude 1 mm 15 bis 150 Hz, Beschleunigung 0,5g

### **ANBRINGUNG DER AUSRÜSTUNGEN**

Der Regler muß in ein Pult eingebaut sein, damit der Bediener nicht zu oft auf die hinteren Anschlüsse zugreifen muß.



Για την αποφυγή του κινδύνου ηλεκτροπληξίας που θα μπορούσε να προκαλέσει προσωπικό τραυματισμό, ακολουθείστε όλες τις υποδείξεις ασφαλείας αυτών των οδηγιών.



Το σύμβολο αυτό προειδοποιεί το χρήστη για πιθανό ηλεκτρικό κίνδυνο σε περίπτωση επαφής με επικίνδυνα μέρη της συσκευής.



Προστατευτικό τερματικό γείωσης. Παρέχεται για σύνδεση με τον αγωγό προστατευτικής γείωσης του συστήματος τροφοδοσίας.

- Εάν ο εξοπλισμός χρησιμοποιηθεί κατά τρόπο που δεν προβλέπεται από τον κατασκευαστή, διακινδυνεύεται η παρεχόμενη από τον εξοπλισμό προστασία.
- Μην αντικαταστήσετε κανένα μέρος (ή εξάρτημα) του οποίου η αντικατάσταση δεν προβλέπεται από τον κατασκευαστή.
- Όλες οι ηλεκτρικές εγκαταστάσεις πρέπει να είναι σύμφωνες με τα τοπικά πρότυπα και να πραγματοποιούνται από έμπειρους τεχνικούς.
- Το τερματικό εδάφους πρέπει να συνδέεται πριν από κάθε άλλη σύνδεση (και να αποσυνδέεται τελευταίο).
- Απαιτείται ένας διακόπτης στην κύρια ηλεκτρική εγκατάσταση τροφοδοσίας ηλεκτρικού κοντά στη συσκευή.

#### ΧΑΡΑΚΤΗΡΙΣΤΙΚΑ ΕΞΟΠΛΙΣΜΟΥ

Τροφοδοσία ισχύος	85 ως 265 V ac/dc
Συχνότητα	50 – 60 Hz
Ισχύς ρεύματος	45 VA
Ηλεκτρική ασφάλεια	2.0 A / 250 V ac/dc

#### ΣΥΝΘΗΚΕΣ ΠΕΡΙΒΑΛΛΟΝΤΟΣ

Αποφεύγετε τη λειτουργία του κοντά σε εύφλεκτα υγρά ή αέρια. Η λειτουργία οποιασδήποτε ηλεκτρικής συσκευής σε τέτοιο περιβάλλον εκθέτει σε κίνδυνο για την ασφάλεια.

Θερμοκρασία	Περιβάλλοντος : 0 ως 50°C
	Αποθήκευσης : -20 ως 70°C
Υγρασία	10 ως 90 % RH μη συμπυκνώσιμη / 40°C
Δόνηση	5 – 15 Hz, ΜΕΓΕΘΟΣ 1 DD
	15 – 150 Hz Επιτάχυνση 0.5 γ

#### ΕΓΚΑΤΑΣΤΑΣΗ ΕΞΟΠΛΙΣΜΟΥ

Η μονάδα αυτή πρέπει να μπει μέσα σε πλαίσιο για να περιορίζεται η πρόσβαση του χρήστη στα πίσω τερματικά.



Per ridurre i rischi di scariche elettriche che potrebbero causare alle persone, seguire tutte le precauzioni circa la sicurezza indicate in questa documentazione.



Questo simbolo avverte del pericolo di scossa elettrica nelle aree in cui sono accessibili conduttori sotto tensione.



Terminale di protezione verso terra. Previsto per il collegamento del conduttore di protezione verso terra del sistema di alimentazione.

- Se lo strumento viene utilizzato in modo diverso dalla specifica del costruttore, la protezione fornita dallo strumento può essere diversa.
- Non sostituire alcun componente (o parte) non specificato esplicitamente come ricambio dal vostro fornitore.
- Tutti i cablaggi devono essere in accordo con i regolamenti locali e devono essere eseguiti da personale esperto ed autorizzato.
- Il terminale di massa deve essere collegato prima di ogni altro filo (e scollegato per ultimo).
- E' necessario che sia presente un interruttore nell'alimentazione principale accanto all'apparecchio.

### **ALIMENTAZIONE APPARECCHIATURA**

Tensione di alimentazione	Da 85 a 265 Vca/cc
Frequenza	50 – 60 Hz
Potenza o corrente	45 VA
Fusibile	2 A / 250 Vca/cc

### **CONDIZIONI AMBIENTALI**

Non far funzionare l'apparecchio in presenza di liquidi o gas infiammabili, in quanto questo potrebbe essere estremamente pericoloso.

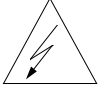
Temperatura	Ambiente : da 0 a 50°C Stoccaggio : da -20 a 70°C
Umidità relativa	Da 10 a 90% UR non condensata a 40°C
Vibrazioni	Da 5 a 15 Hz, ampiezza 1 mm Da 15 a 150 Hz, accelerazione 0,5 g

### **INSTALLAZIONE DELL'APPARECCHIO**

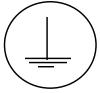
Il apparecchio deve essere montato su un pannello per limitare l'accesso ai terminali posteriori.



Følg alle retningslinjene i dette dokumentet, slik at du reduserer risikoen for elektrisk støt og mulige personskader.



Dette symbolet advarer brukeren om tilgjengelige terminaler med farlige spenninger og en potensiell fare for elektrisk støt.



Jordingsterminal. kablen for jording av systemet skal tilknyttes til denne terminalen.

- Dersom utstyret benyttes på en måte annerledes enn spesifisert av produsent, kan utstyrets beskyttelsesgrad forringes.
- Ingen komponenter eller deler skal skiftes ut dersom de ikke er uttrykkelig spesifisert som utskiftbare av din forhandler.
- Det er påkrevet med en hovedstrømsbryter i nærheten av utstyret.
- All kabling må utføres i henhold til gjeldende forskrifter og installeres av autoriser og erfaren installatør.
- Jord må tilknyttes før all annen kabling (og frakobles sist).

### **UTSTYRSPESIFIKASJONER**

Strømtilførsel	85 til 265 V AC/DC
Nettfrekvens	50 – 60 Hz
Kraftforbruk	45 VA
Sikringstørrelse	2 A / 250 V AC/DC

### **OMGIVELSER**

Instrumentet må ikke opereres i nærheten av lettantennelige væsker eller gasser. Bruk av elektriske instrumenter i slike omgivelser utgjør en sikkerhetsrisiko.

Temperatur	omgivelse : 0 til 50°C lagring : -20 til 70°C
Fuktighet	10 til 90% HR ingen kondensering / 40°C
Vibrasjon	5 til 15 Hz, amplitude 1 mm 15 til 150 Hz, akselerasjon 0,5 g

### **UTSTYRSINSTALLASJON**

Pass på å montere panelene på regulatoren, slik at berøring av terminalene på baksiden forhindres.



Para reduzir o risco de choque eléctrico que pode causar danos corporais, seguir todas as normas de segurança contidas nesta documentação.



Este símbolo avisa o utilizador sobre um eventual perigo de choque quando são acessíveis voltagens sob tensão perigosas.



Terminal de protecção de terra. Fornecido para ligação do condutor do sistema da protecção de terra.

- Se este equipamento for usado de modo não especificado pelo fabricante, a protecção fornecida pelo equipamento pode não ser adequada.
- Não se deve substituir qualquer componente (ou peça) que não seja explicitamente especificado como substituível pelo nosso revendedor.
- Toda a cablagem deve estar de acordo com os códigos eléctricos locais e deve ser realizada por pessoal experiente devidamente autorizado.
- O terminal de terra deve ser ligado antes de ser feita qualquer outra cablagem (e desligado em último lugar).
- Recomenda-se um comutador na fonte de alimentação principal próximo do equipamento.

### **ESPECIFICAÇÕES DO EQUIPAMENTO**

Voltagem	85 a 265 Vca/cc
Frequência	50 – 60 Hz
Potência ou consumo de corrente	45 VA
Fusíveis	2 A / 250 Vca/cc

### **CONDIÇÕES AMBIENTAIS**

Não operar o instrumento na presença de líquidos ou vapores inflamáveis. A operação de qualquer instrumento eléctrico em tal ambiente constitui um perigo para a segurança.

Temperatura	Ambiente : 0 a 50°C Armazenamento : -20 a 70°C
Humidade	10 a 90% RH não condensado a 40°C
Vibração	5 a 15 Hz, amplitude 1 mm 15 a 150 Hz, aceleração 0,5 g

### **INSTALAÇÃO DO EQUIPAMENTO**

O Registrador deve ser montado num painel para limitar o acesso do operador aos terminais traseiros.



Para reducir el riesgo de choque eléctrico el cual podría causar lesiones personales, seguir todas las indicaciones de este documento.



Este símbolo previene al usuario de un riesgo potencial de descarga cuando se puede acceder a corrientes de tensión peligrosas.



Terminal de tierra de protección. Proporcionado para la conexión de la tierra de protección del conductor del sistema de alimentación.

- Si el equipo es utilizado de forma no especificada por el fabricante, la protección suministrada con el mismo podría resultar dañada.
- No reemplazar ningún componente (o parte) no explícitamente especificado por el suministrador.
- Todo el cableado debe realizarse de acuerdo con las normas eléctricas locales y debe ser realizado por personal experimentado.
- El terminal de tierra debe ser conectado antes que cualquier otro cable y desconectado el último.
- Se recomienda la instalación de un interruptor de la alimentación principal, cerca del equipo.

### **DATOS ELECTRICOS DEL EQUIPO**

Tensión de alimentación	85 a 265 V AC/DC
Frecuencia	50 – 60 Hz
Potencia o corriente	45 VA
Fusible	2 A / 250 V AC/DC

### **CONDICIONES AMBIENTALES**

No operar con el instrumento en presencia de líquidos o gases inflamables. La operación de cualquier equipo eléctrico en tal ambiente constituye un riesgo contra la seguridad.

Temperatura	Ambiente : 0 a 50°C Almacenamiento : -20 a 70°C
Humedad	10 a 90% RH sin condensados a 40°C
Vibración	5 a 15 Hz, amplitud 1 mm 15 a 150 Hz, aceleración 0,5 g

### **INSTALACION DEL EQUIPO**

Este equipo debe ser montado en un panel para limitar al operador el acceso a los terminales traseros.



För att reducera riskerna av elektriska chocker som kan orsaka personskador, följ alla säkerhetsföreskrifter i denna dokumentation.



Denna symbol varnar användaren för risk för elchock vid tillfällig åtkomst av spänningsförande del.



Anslutning av skyddsjord. Avsedd för anslutning av elsystemets skyddsjordsledare.

- Om utrustningen används på ett sådant sätt, att det inte innefattas av tillverkarens specifikation, kan de inbyggda säkerhetsfunktionerna äventyras.
- Ersätt aldrig någon komponent (eller del) som inte är specificerad som ersättningsbar av tillverkaren.
- All ledningsdragnings måste utföras i enlighet med lokala bestämmelser och skall utföras av behörig personal med erfarenhet av sådant arbete.
- Skyddsjordsanslutningen skall anslutas före alla andra anslutningar (och losskopplas sist).
- En strömbrytare för näströmmen rekommenderas.

### **STRÖMFÖRSÖRJNING**

Spänning	85 a 265 V AC/DC
Frekvens	50 – 60 Hz
Effekt eller märkström	45 VA
Säkringsvärde	2 A / 250 V AC/DC

### **OMGIVNINGSVILLKOR**

Använd ej instrumentet i närhet av brännbara vätskor eller gaser. Användandet av instrumentet i sådant miljö är en direkt säkerhetsrisk.

Temperatur	Omgivande : 0 till 50°C Förvaring : -20 till 70°C
Fuktighet	10 till 90% RH ej kondenserande / 40°C
Vibration	5 till 15 Hz, amplitud 1 mm 15 till 150 Hz, acceleration 0,5 g

### **INSTALLATION**

Instrumentet skall monteras i en panel eller i en låda för att undvika att personalen kommer i beröring med bakre inkopplingsplintar.





# HONEYWELL SERVICE CENTERS

## ARGENTINA

HONEYWELL S.A.I.C.  
BELGRANO 1156  
BUENOS AIRES  
ARGENTINA  
Tel. : 54 1 383 9290

## BULGARIA

HONEYWELL EOOD  
14, Iskarsko Chausse  
POB 79  
BG- 1592 Sofia  
BULGARIA  
Tel : 359-791512/ 794027/ 792198

## GERMANY

HONEYWELL AG  
Kaiserleistrasse 39  
D-63067 OFFENBACH  
GERMANY  
Tel. : 49 69 80 640

## ASIA PACIFIC

HONEYWELL ASIA PACIFIC Inc.  
Room 3213-3225  
Sun Kung Kai Centre  
N° 30 Harbour Road  
WANCHAI  
HONG KONG  
Tel. : 852 829 82 98

## CANADA

HONEYWELL LIMITED  
THE HONEYWELL CENTRE  
529 Mc Nicoll Avenue  
M2H 2C9 NORTH YORK,  
ONTARIO  
CANADA  
Tel. : 416 502 5200

## HUNGARY

HONEYWELL Kft  
Gogol u 13  
H-1133 BUDAPEST  
HUNGARY  
Tel. : 36 1 451 43 00

## AUSTRALIA

HONEYWELL LIMITED  
5 Thomas Holt Drive  
North Ryde Sydney  
NSW AUSTRALIA 2113  
Tel. : 61 2 353 7000

## CZECH REPUBLIC

HONEYWELL, Spol.s.r.o.  
Budejovicka 1  
140 21 Prague 4  
Czech Republic  
Tel. : 42 2 6112 3434

## ICELAND

HONEYWELL  
Hataekni .hf  
Armuli 26  
PO Box 8336  
128 reykjavik  
Iceland  
Tel : 354 588 5000

## AUSTRIA

HONEYWELL AUSTRIA G.m.b.H.  
Handelskai 388  
A1020 VIENNA  
AUSTRIA  
Tel. : 43 1 727 800

## DENMARK

HONEYWELL A/S  
Automatikvej 1  
DK 2860 Soeborg  
DENMARK  
Tel. : 45 39 55 56 58

## ITALY

HONEYWELL S.p.A.  
Via P. Gobetti, 2/b  
20063 Cernusco Sul Naviglio  
ITALY  
Tel. : 39 02 92146 1

## BELGIUM

HONEYWELL S.A.  
3 Avenue de Bourget  
B-1140 BRUSSELS  
BELGIUM  
Tel. : 32 2 728 27 11

## FINLAND

HONEYWELL OY  
Ruukintie 8  
FIN-02320 ESPOO 32  
FINLAND  
Tel. : 358 0 3480101

## MEXICO

HONEYWELL S.A. DE CV  
AV. CONSTITUYENTES 900  
COL. LOMAS ALTAS  
11950 MEXICO CITY  
MEXICO  
Tel : 52 5 259 1966

## BRAZIL

HONEYWELL DO BRAZIL AND CIA  
Rua Jose Alves Da Chunha  
Lima 172  
BUTANTA  
05360.050 SAO PAULO SP  
BRAZIL  
Tel. : 55 11 819 3755

## FRANCE

HONEYWELL S.A.  
Bâtiment « le Mercury »  
Parc Technologique de St Aubin  
Route de l'Orme (CD 128)  
91190 SAINT-AUBIN  
FRANCE  
Tel. from France: 01 60 19 80 00  
From other countries: 33 1 60 19 80 00

## THE NETHERLANDS

HONEYWELL BV  
Laaderhoogtweg 18  
1101 EA AMSTERDAM ZO  
THE NETHERLANDS  
Tel : 31 20 56 56 911

# HONEYWELL SERVICE CENTERS

## NORWAY

HONEYWELL A/S  
Askerveien 61  
PO Box 263  
N-1371 ASKER  
NORWAY  
Tel. : 47 66 76 20 00

## POLAND

HONEYWELL Sp.z.o.o  
UI Domainewksa 41  
02-672 WARSAW  
POLAND  
Tel. : 48 22 606 09 00

## PORTUGAL

HONEYWELL PORTUGAL LDA  
Edificio Suecia II  
Av. do Forte nr 3 - Piso 3  
2795 CARNAXIDE  
PORTUGAL  
Tel. : 351 1 424 50 00

## REPUBLIC OF IRELAND

HONEYWELL  
Unit 1  
Robinhood Business Park  
Robinhood Road  
DUBLIN 22  
Republic of Ireland  
Tel. : 353 1 4565944

## REP. OF SINGAPORE

HONEYWELL PTE LTD  
BLOCK 750E CHAI CHEE ROAD  
06-01 CHAI CHEE IND. PARK  
1646 SINGAPORE  
REP. OF SINGAPORE  
Tel. : 65 2490 100

## REPUBLIC OF SOUTH AFRICA

HONEYWELL  
Southern Africa  
PO BOX 138  
Milnerton 7435  
REPUBLIC OF SOUTH AFRICA  
Tel. : 27 11 805 12 01

## ROMANIA

HONEYWELL Office  
Bucharest  
147 Aurel Vlaicu Str., Sc.Z.,  
Apt 61/62  
R-72921 Bucharest  
ROMANIA  
Tel : 40-1 211 00 76/ 211 79 43

## RUSSIA

HONEYWELL INC  
4<sup>th</sup> Floor Administrative  
Building of AO "Luzhniki"  
Management  
24 Luzhniki  
119048 Moscow  
RUSSIA  
Tel : 7 095 796 98 00/01

## SLOVAKIA

HONEYWELL Ltd  
Mlynske nivy 73  
PO Box 75  
820 07 BRATISLAVA 27  
SLOVAKIA  
Tel. : 421 7 52 47 400/425

## SPAIN

HONEYWELL S.A  
Factory  
Josefa Valcarcel, 24  
28027 MADRID  
SPAIN  
Tel. : 34 91 31 3 61 00

## SWEDEN

HONEYWELL A.B.  
S-127 86 Skarholmen  
STOCKHOLM  
SWEDEN  
Tel. : 46 8 775 55 00

## SWITZERLAND

HONEYWELL A.G.  
Hertistrasse 2  
8304 WALLISELLEN  
SWITZERLAND  
Tel. : 41 1 831 02 71

## TURKEY

HONEYWELL Otomasyon ve  
Kontrol  
Sistemlen San ve Tic A.S.  
(Honeywell Turkey A.S.)  
Emirhan Cad No 144  
Barbaros Plaza C. Blok Kat 18  
Dikilitas 80700 Istanbul  
TURKEY  
Tel : 90-212 258 18 30

## UNITED KINGDOM

HONEYWELL  
Unit 1,2 &4 Zodiac House  
Calleva Park  
Aldermaston  
Berkshire RG7 8HW  
UNITED KINGDOM  
Tel : 44 11 89 81 95 11

## U.S.A.

HONEYWELL INC.  
INDUSTRIAL CONTROLS DIV.  
1100 VIRGINIA DRIVE  
PA 19034-3260 FT. WASHINGTON  
U.S.A.  
Tel. : 215 641 3000

## VENEZUELA

HONEYWELL CA  
APARTADO 61314  
1060 CARACAS  
VENEZUELA  
Tel. : 58 2 239 0211



**Honeywell**

---

**Sensing and Control**  
Honeywell  
11 West Spring Street  
Freeport, IL 61032