

DIMENSIONS

FX1900-0000

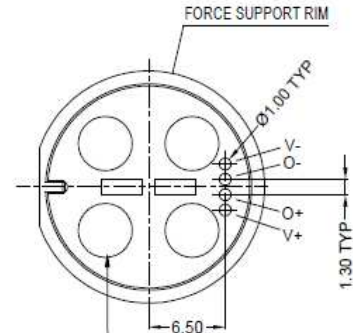
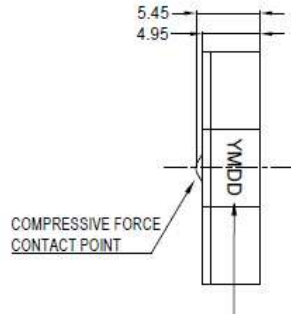
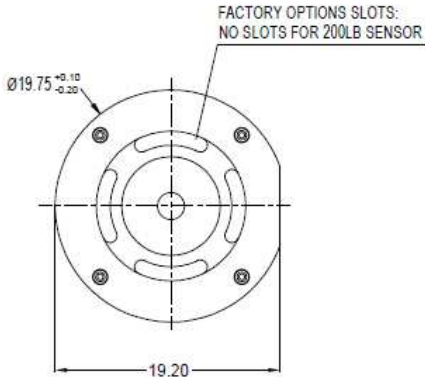

Y-YEAR(1-2011,2-2012,3-2013.....);
M-MONTH(1-Jan,2-Feb.....A-Oct,B-Nov,C-Dec);
DD-DATE.
NOTED WITH OILINESS PEN.

DELICATE SENSOR ELEMENTS INSIDE THE 4 BUMPS
PROTRUDING 1.0MM MAX ABOVE RIM, DO NOT APPLY
ANY FORCE.

FX1900-XXX1

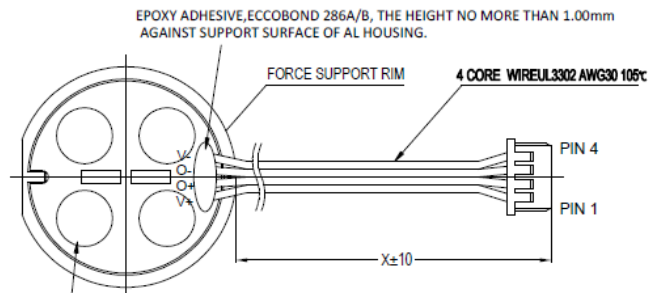
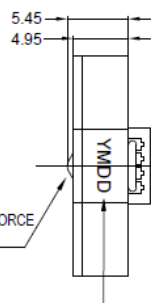
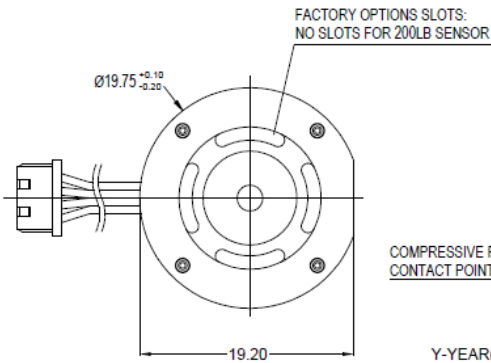

Y-YEAR(1-2011,2-2012,3-2013.....);
M-MONTH(1-Jan,2-Feb.....A-Oct,B-Nov,C-Dec);
DD-DATE.
NOTED WITH OILINESS PEN.

THE PUMP OF RUBBER SHOULD BE FREE FROM PRESS & SCRATCH.
THE HIGHNESS NO MORE THAN 1.0mm AGAINST SUPPORT SURFACE
OF AL HOUSING.

FX1901-0001

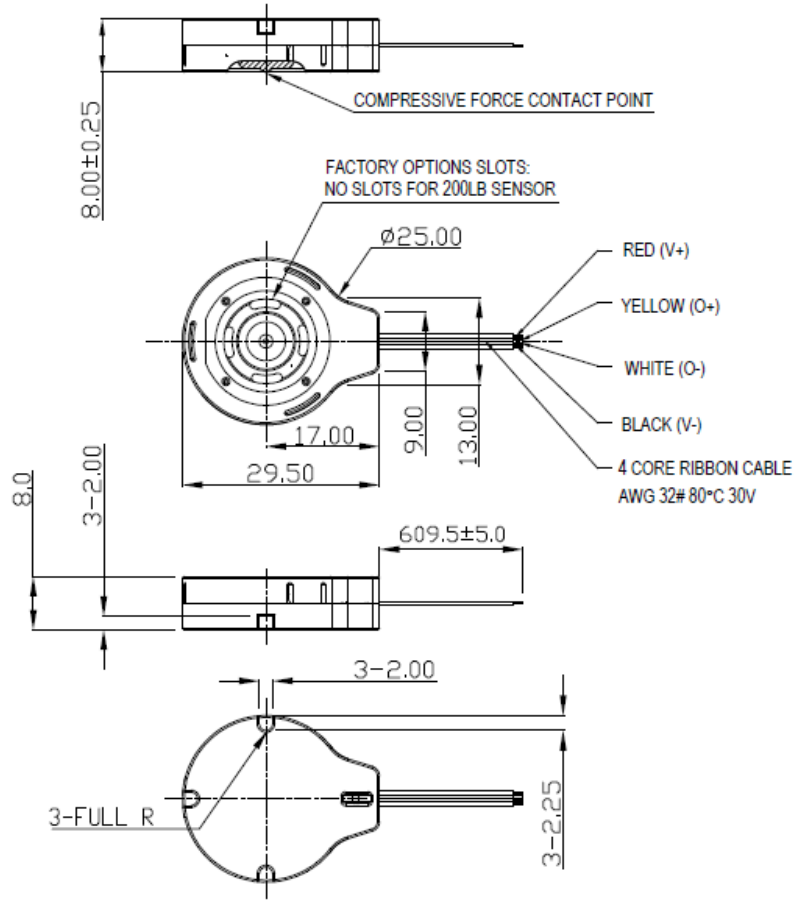

WIRING INFORMATION

FX1900-0000

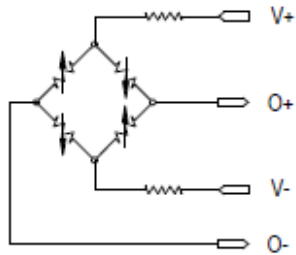

FX1900-XXX1 FX1901-0001

