

# SM-UART-04L

## Laser Dust Sensor



SM-UART-04L Laser Dust Sensor is designed to operate in a moderate environment and provides excellent performance. It's embedded optical design leverages the strength from laser technology, which allows customers to achieve excellent performance with balanced reliability. SM-UART-04L is an ideal solution for industrial and consumer applications.

SM-UART-04L laser dust sensor detects dust particle concentration in air by using an optical sensing method. A laser light emitting diode (laser LED) and a photo sensor are optically arranged in the device. The photo sensor detects the reflected laser LED light by dust particles in air. The dust sensor can detect small particles such as, cigarette smoke and distinguish small particles, such as smoke from large house dust, by the pulse pattern of the signal output.

### Features

- Laser Optical Dust
  - High Accuracy
  - Fast Response
- UART Output
- Compact in Size
- Flexible Mounting Style

### Applications

- Indoor Air Quality Monitoring
- Air Cleaners and Purifiers
- Air Conditioners and HVAC
- Outdoor Dust Monitoring

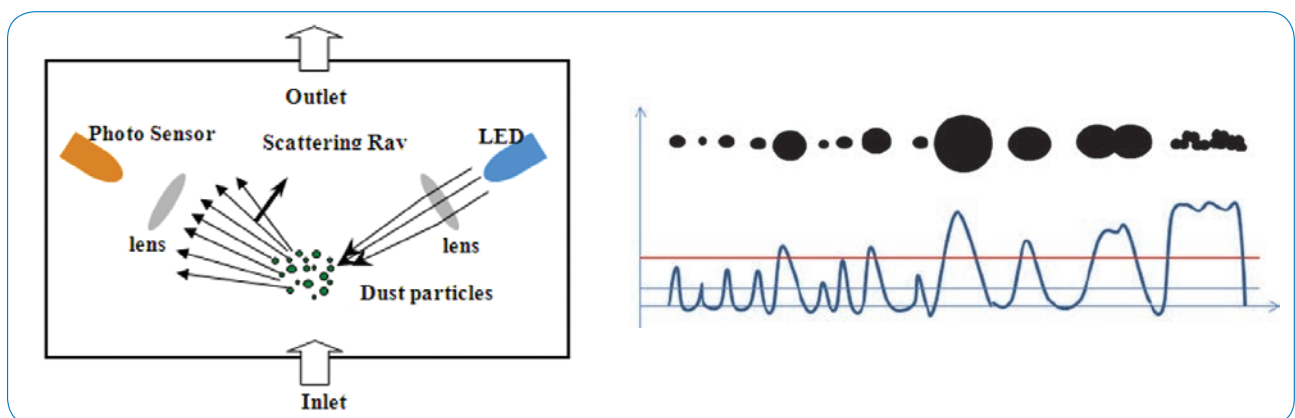

**Amphenol**  
Advanced Sensors

Figure 1 : Detection Principle

# SM-UART-04L Laser Dust Sensor

## Block Diagram

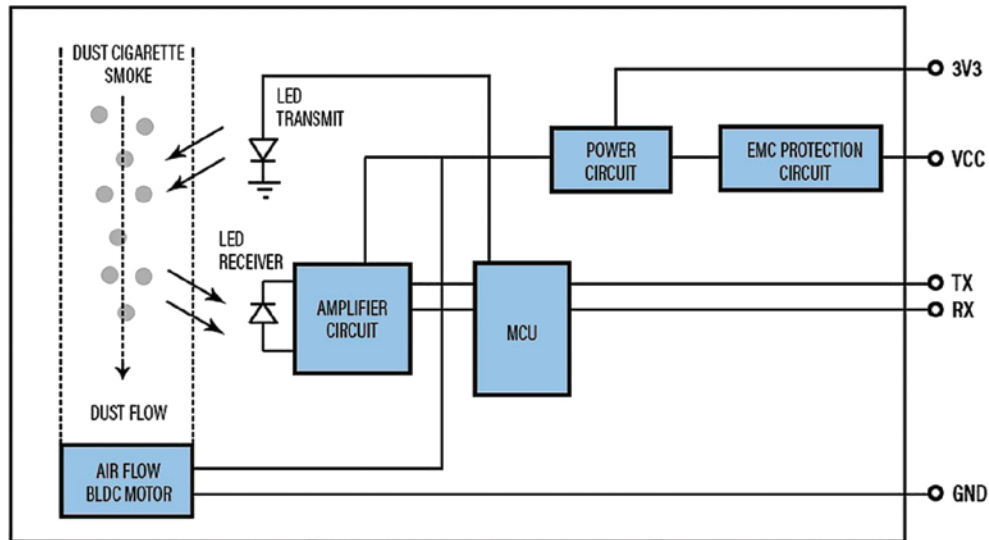

## Calibration

Calibration carried out with cigarette smoke per GB/T1880

## Absolute Maximum Ratings

Absolute Maximum Ratings			
Parameter	Symbol	Rating	Unit
Supply Voltage	Vcc	0 to + 5.5	V
Operating Temperature	Topr	-10 to 50	°C
Storage Temperature	Tstg	-30 to 70	°C
Operating Humidity <sup>(1)</sup>	RHopr	0 to 95	%
Storage Humidity <sup>(1)</sup>	RHstg	0 to 95	%

1) Non-condensing

## Electrical Characteristics

Parameter	Symbol	Min.	Typ.	Max.	Unit	
Particle Size	D	0.3	2.5	10	um	
Detection Range	D <sub>reg</sub>	1	—	999	µg/m <sup>3</sup>	
Resolution	R	—	1	—	µg /m <sup>3</sup>	
Indication Error <sup>(2)</sup>	1 ~100 ug/m <sup>3</sup>	D <sub>err</sub>	—	—	+/-10	µg /m <sup>3</sup>
	100~999 ug/m <sup>3</sup>		—	—	+/-10	%
Warm-Up Time	t <sub>wup</sub> <sup>(2)</sup>	—	5	—	s	
Response Time	t <sub>rsp</sub> <sup>(2)</sup>	—	1	—	s	
Average Trouble-free Working Time	T	—	40000	—	hour	
Supply Voltage	V <sub>cc</sub>	4.8	5	5.2	V	
Supply Voltage Ripple	V <sub>cc</sub> Ripple	—	—	30	mV	
Current Consumption	I <sub>cc</sub> <sup>(2)</sup>	—	60	100	mA	
Output (UART)			3.3V			

1) Non-condensing

2) Testing at T=25°C, RH=40-60%