

RECTIVAR[®] 4 series 541-641

Analog speed controllers
for DC motors

User's manual

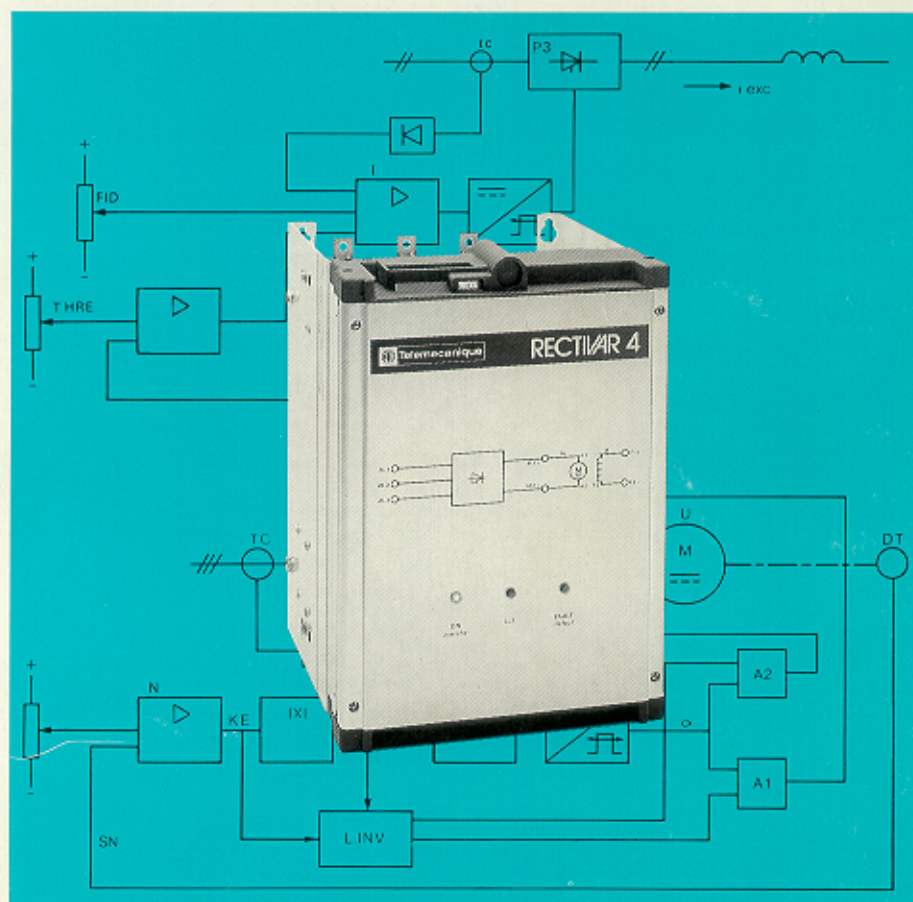

From 16 to 3000A
220V to 660V three-phase power supply

Contents

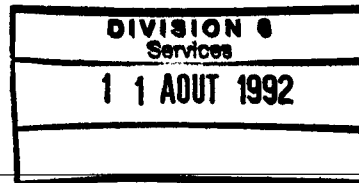

	Page
Presentation - General	4 to 7
Definition of Rectivar	
- Selection guide	8 to 11
- Characteristics	12
- Connection terminals	
• Power bridge	13
• Power interface boards	14-15
• Control board	16
• Specific uses	17 to 19
Installation of Rectivar	
- Precautions	20-21
- Dimensions and weights	22 to 25
- Power connections	26-27
- Component layout	
• RTV-541 - power bridge	28 to 31
• RTV-641 - power bridge	32 to 35
- Power interface board	
• RTV-641 16A	36
• RTV 32 to 650A	37
• RTV 800 to 3000A	38
and rating connector J4	38
• Controlled field board	39
• Control board	40
• Adjustment board	41
Utilisations of Rectivar	
- Simplified sequence diagrams	42 to 45
Connections	
- Rectivar control board	46 to 52
- Controlled field board	53
Operational extension	
- Use of the galvanic insulation board	54 to 56
Commissioning	
- Preliminary checks	57 to 59
- Static adjustments	60-61
- Dynamic adjustments	62 to 64
- Specific uses	65 to 67
Accessories and spare parts	68-69
Block diagram	70-71

DIVISION 8
SECTION 28
1 AUG 1993



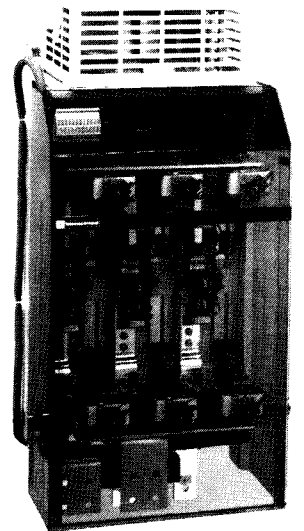
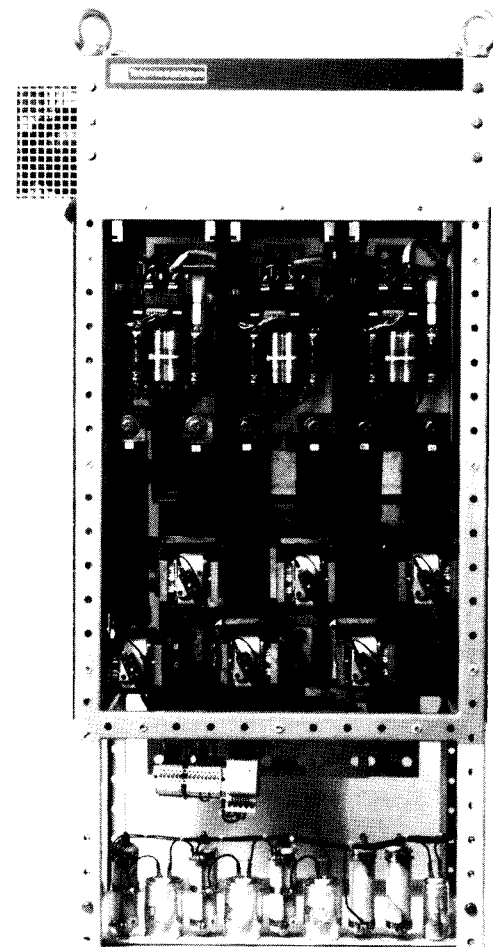
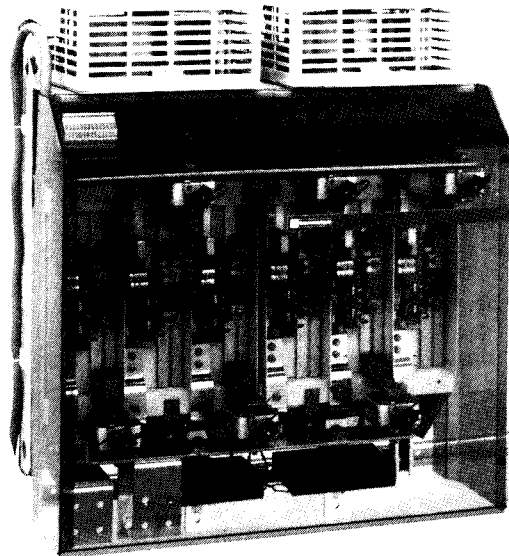
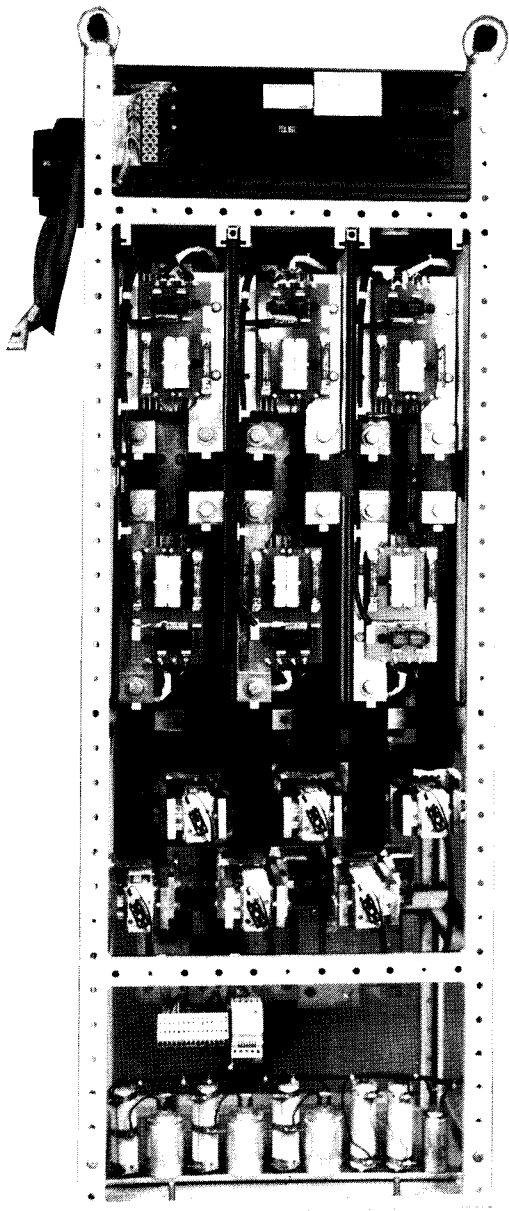

Presentation - General

RTV-541 unidirectional 2 quadrants
RTV-641 static reversing 4 quadrants

The RECTIVAR RTV-541 single bridge 32 to 3000A three-phase speed controllers are designed for speed regulation of DC motors from 6 to 1690 kW with separate field supply. The RECTIVAR RTV-641 double bridge 16 to 3000A three-phase speed controllers are designed for speed regulation of DC motors from 2.7 to 1530 kW with separate field supply. The two series are supplied from the three-phase AC network.

Ratings: I (A)	16, 32, 48, 72, 180, 270, 400, 650, 800, 1250, 1750, 3000
Mains voltage (V)	up to 440, 500 or 660 Volts depending on ratings - 50/60Hz
Speed range	1 to 300 - control by tachogenerator 1 to 20 by voltage feedback, but with accuracy depending on motor

Characteristics

The RTV-541 speed controllers will operate in quadrants 1 and 4 or 2 and 3 of the torque-speed plan. The RTV-641 speed controllers will operate in the 4 quadrants of the torque-speed plan. From the 800A rating up, both series feature a field current regulator.

Composition

The RECTIVAR 541/641 range includes, for each of the series:

- 7 ratings from 32 to 650A using compact technology. The 16A rating is only available for RTV-641,
- 4 ratings from 800 to 3000A using modular technology.

- Compact technology features in the same metal case:

- the power section with a bridge with 6 or 12 thyristors and their protections, the control transformer, a power interface board and its daughter board for a 12-thyristor bridge, current transformers and ventilation when needed,
- the control rack on the front panel of the speed controller, for all 8 ratings, includes the control board and the plug-in "adjustment" board.

- The modular technology features a power chassis and a control module connected by a set of cables, 2 meters long, sleeved wires.

- The power chassis includes:
a bridge with 6 or 12 thyristors and their protections, the firing circuits, the current transformers, the protection fuses of the thyristors and the ventilation with its safety devices.

- The "control" module:
identical for the 4 ratings and including:

- the thyristorized field supply bridge,
- the current transformer,
- the controlled field board,
- the control transformers,
- a power interface board,
- the control rack, identical to that described above and located on the front panel.

In both technologies, the control rack is mounted on hinges and swings to provide access to the rear.

Control is totally isolated from the power section, and the maximum voltage is 24V DC.

Presentation - General

Power interface boards
Control rack

Power interface boards

• Type VX5-RLD101 for 16A rating

This board contains: (see details on page 36)

- the regulated supply sources,
- the thyristor firing and protection circuits,
- the complete double bridge with 12 thyristors,
- the link adapting the control transformer voltage (CAV4),
- the two assignable function output relays, K1 and K2,
- the current transformers.

• Type VZ5-RZD109 for ratings from 32 to 650A

This board includes: (see details on page 37)

- the regulated supply sources,
- the thyristor firing and protection circuits,
- the speed controller rating customizing unit (RT),
- the link adapting the control transformer voltage (CAV4),
- the 3 power/control separation links (CAL) providing separate power and control supplies when in position 1,
- the 2 assignable function output relays: K1 and K2,
- the "6 firing gate" daughter board for a 12-thyristor bridge.

• Type VX5-RZD202 for ratings from 800 to 3000A

This board includes: (see details on page 38)

- the regulated supply sources,
- the pulse transformer control circuits for the power bridge,
- the rating connector (J4),
- the field bridge thyristor firing and protection circuit,
- the link adapting the control transformer voltage,
- the link adapting the field transformer voltage,
- the two field power/control separation links,
- the two assignable function output relays: K1 and K2,

Controlled field board (Ratings 800 to 3000A)

This board groups together the following functions: (see page 39)

- the field current regulation,
- the pulsetrain firing gate circuit,
- the energizing and de-energizing safety device,
- the field presence safety device,
- the "reduced flux" function,
- the voltage regulation and safety circuits.

Analog control rack

The rack contains an analog control board.

It is common to the entire RTV541/641 range and features the following characteristics:

- 4-point attachment,
- plug-in terminals for external connections to the lower part of the board,
- adjustments by links and potentiometers grouped together on a plug-in "adjustment" board including only passive components and indication LED's,
- possibility of mounting options (see page 59).

This board can be changed without tools: the adjustment memory is preserved by the "adjustment" board.

It groups together the following functions:

- the effective reversing logic for RTV641,
- the dual loop cascaded current regulation,
- the proportional, integral and derived action speed servo control,
- the armature current limitation function,
- the pulsetrain firing gate circuit,
- the energizing and de-energizing safety device,
- the field current presence safety device,
- the ramp,
- the control logic,
- the 8 LED's, of which 3 are visible with the cover fitted.

Presentation-General

Dialogue

Dialogue by LED's and relays

- 8 LED's and 2 relays for all ratings
 - 4 red LED's, 3 green LED's and 1 yellow LED,
 - 2 relays assignable by wiring.

Data supplied by externally visible LED's:

- ON : the speed controller has received the validation data --> green LED lit,
- IA > : speed controller in current limitation --> yellow LED lit,
- FAULT : fault --> red LED lit.

- 3 complementary LED's for ratings \geq C80 in the lower section:

- ON : field regulator energized,
- IF < : field current fault,
- UA > : armature overvoltage fault.

- Information supplied by the relays in the standard version:

- validated speed controller: K1 mounted, contact closed,
- speed controller out of current limitation: K2 mounted, contact closed.

It is possible to attribute other functions to the relays (see page 18).

Choice of motor

The motor must be designed and rated for a pulsed current supply with speed variation and torque corresponding to the service to be provided.

Form factor: 1.05.

Separate excitation or permanent magnet excitation will be designed. Do not use a series or compound excitation motor.

In the case of controlled excitation, the maximum field voltage will be 0.8 times the network voltage.

In the case of de-energizing, the maximum field voltage will be 0.5 times the network voltage. However, for machines with slow acceleration and deceleration (ramps > 5s), up to 0.8 times the network voltage is possible.

E.g.: 190V for a 380V AC network voltage.

Recommended armature voltage: \leq network voltage x 1.16 for RTV-541
 \leq network voltage x 1.05 for RTV-641

Presentation-General

Functional diagrams

• Compact technology

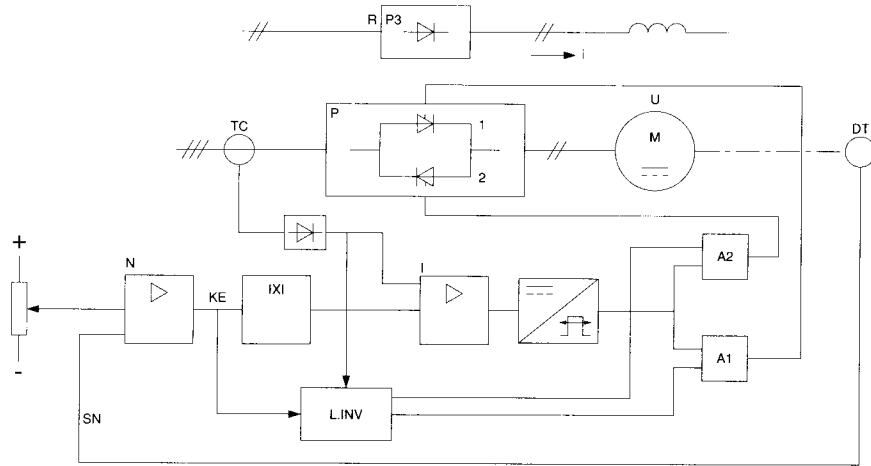

• Modular technology

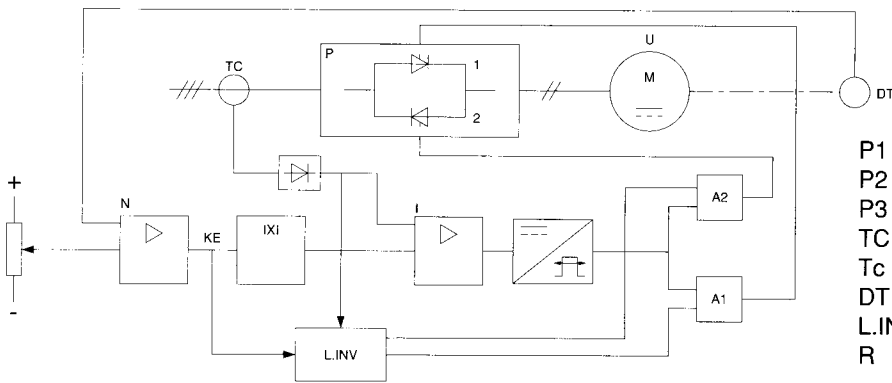

- P1 : 3 phase Graetz bridge
- P2 : 3 phase Graetz bridge (for RTV-641)
- P3 : 2 phase Graetz bridge
- TC : motor current measurement
- Tc : field current measurement
- DT : motor speed measurement
- L.INV : bridge control logic according to sign of KE
- R : field power supply

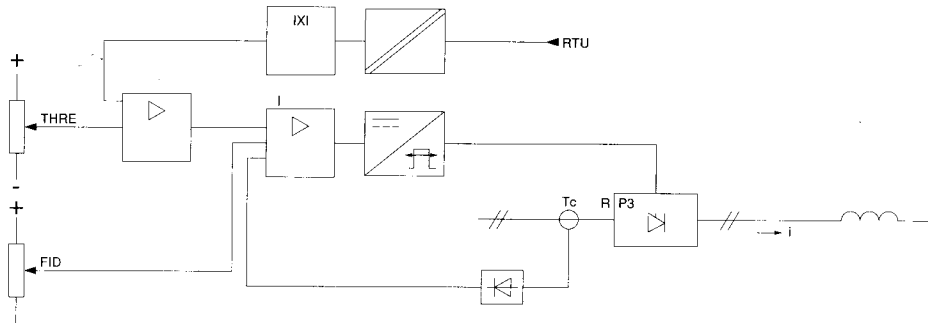

Definition of RECTIVAR 4

Selection guide

Speed controller - motor combination

The speed controller reference appearing on the delivery note and on the nameplate on the left hand side of the equipment must be specified for all communications with our departments. Check the NETWORK-SPEED CONTROLLER-MOTOR compatibility from the following tables. The indicated values correspond to an ambient temperature of 40°C. Beyond and up to 60°C, apply a current derating of 1.2% for each additional °C.

Three-phase power supply $U_n \pm 10\%$
Network 50/60Hz ± 2 Hz

Speed controller RTV-541 Max. permanent current A	AC line Irms A	Motor Max. power with $T_d/T_n = 1.2$								Field A	Rectivar Reference (1)	Weight kg
		220V kW	380V kW	415V kW	440V kW	480V kW	500V kW	660V kW				
32	24	6	10	10.5	12	11.5	13	-	15	RTV-541D32•	6.500	
48	36	9	15	16	18	17	19.5	-	15	RTV-541D48•	10.000	
72	54	13.5	23	24	27	26	30	-	15	RTV-541D72•	10.000	
180	135	33.5	57.5	60	67.5	65	75	-	15	RTV-541C18•	11.000	
270	203	51	86	90	101	97	112	-	15	RTV-541C27•	13.000	
400	300	78	132	138	166	150	171	-	15	RTV-541C40•	47.000	
650	488	127	214	224	253	243	278	-	15	RTV-541C65•	47.000	
800	600	156	264	275	312	300	342	450	30 (2)	RTV-541C80•	54.000	
1250	938	244	413	432	487	469	535	704	30 (2)	RTV-541M12•	54.000	
1750	1313	342	578	604	683	657	749	985	30 (2)	RTV-541M17•	60.000	
3000	2250	585	990	1035	1170	1125	1285	1690	30 (2)	RTV-541M30•	220.000	
Armature voltage		260V	440V	460V	520V	500V	570V	750V				
(1) basic reference to be completed with voltage letter												
Voltage		220V	380V	415V	440V	480V	500V	660V				
Voltage letter		Q	Q	Q	Q	S	S	Y				

(2) For ratings C80• to M30•, the Rectivar includes 2 subassemblies (see page 10), with field regulation integrated in the control module and 3 current ratings 10A - 20A - 30A with selection by link.

Definition of RECTIVAR 4

Selection guide

Three-phase power supply $U_n \pm 10\%$
Network 50/60Hz ± 2 Hz

Speed controller RTV-641	AC line current I _{rms}	Motor Max. power with T _d /T _n = 1.2								Field	Rectivar Reference (1)	Weight
		220V kW	380V kW	415V kW	440V kW	480V kW	500V kW	660V kW	A			
16	12	2.7	4.7	5	5.3	-	-	-	-	2	RTV-641D16Q	6.000
32	24	5.5	9.5	10	10.5	11.5	12	-	-	15	RTV-641D32•	6.500
48	36	8	14	15.5	16	17.5	18	-	-	15	RTV-641D48•	10.000
72	54	12	21	23	24	26	27	-	-	15	RTV-641D72•	10.000
180	135	30.5	54	59.5	63	67	70	-	-	15	RTV-641C18•	11.000
270	203	46	81	89	93	101	105	-	-	15	RTV-641C27•	13.000
400	300	69	120	132	138	150	156	-	-	15	RTV-641C40•	47.000
650	488	112	195	214	224	243	253	-	-	15	RTV-641C65•	47.000
800	600	138	240	264	275	300	312	408	-	30 (2)	RTV-641C80•	108.000
1250	938	215	375	413	432	469	487	637	-	30 (2)	RTV-641M12•	108.000
1750	1313	302	525	578	604	657	683	893	-	30 (2)	RTV-641M17•	120.000
3000	2250	518	900	990	1035	1125	1170	1530	-	30 (2)	RTV-641M30•	298.000
Armature voltage		230V	400V	440V	460V	500V	520V	680V				
(1) basic reference to be completed with voltage letter												
Voltage		220V	380V	415V	440V	480V	500V	660V				
Voltage letter		Q	Q	Q	Q	S	S	Y				

(2) For ratings C80• to M30•, the Rectivar includes 2 subassemblies (see page 10), with field regulation integrated in the control module and 3 current ratings 10A - 20A - 30A with selection by link.

Definition of RECTIVAR 4

Selection guide

Composition of modular speed controller

The Rectivar speed controllers types RTV-541 and RTV-641 from C80• to M30• are modular, with separate power and control. Each of the two parts has its own reference.

Rectivar 541	Power part		+Control module	
Reference	Reference	Weight (kg)	Reference	Weight (kg)
RTV-541C80Q	VZ8-DH1C80Q	54	VW3-RZD1021	12
RTV-541C80S	VZ8-DH1C80S	54	VW3-RZD1021	12
RTV-541C80Y	VZ8-DH1C80Y	54	VW3-RZD1021	12
RTV-541M12Q	VZ8-DH1M12Q	54	VW3-RZD1021	12
RTV-541M12S	VZ8-DH1M12S	54	VW3-RZD1021	12
RTV-541M12Y	VZ8-DH1M12Y	54	VW3-RZD1021	12
RTV-541M17Q	VZ8-DH1M17Q	60	VW3-RZD1021	12
RTV-541M17S	VZ8-DH1M17S	60	VW3-RZD1021	12
RTV-541M17Y	VZ8-DH1M17Y	60	VW3-RZD1021	12
RTV-541M30Q	VZ8-DH1M30Q	220	VW3-RZD1021	12
RTV-541M30S	VZ8-DH1M30S	220	VW3-RZD1021	12
RTV-541M30Y	VZ8-DH1M30Y	220	VW3-RZD1021	12

Rectivar 641	Power part		+ Control module	
Reference	Reference	Weight (kg)	Reference	Weight (kg)
RTV-641C80Q	VZ8-DL1C80Q	108	VW3-RZD1021	12
RTV-641C80S	VZ8-DL1C80S	108	VW3-RZD1021	12
RTV-641C80Y	VZ8-DL1C80Y	108	VW3-RZD1021	12
RTV-641M12Q	VZ8-DL1M12Q	108	VW3-RZD1021	12
RTV-641M12S	VZ8-DL1M12S	108	VW3-RZD1021	12
RTV-641M12Y	VZ8-DL1M12Y	108	VW3-RZD1021	12
RTV-641M17Q	VZ8-DL1M17Q	120	VW3-RZD1021	12
RTV-641M17S	VZ8-DL1M17S	120	VW3-RZD1021	12
RTV-641M17Y	VZ8-DL1M17Y	120	VW3-RZD1021	12
RTV-641M30Q	VZ8-DL1M30Q	298	VW3-RZD1021	12
RTV-641M30S	VZ8-DL1M30S	298	VW3-RZD1021	12
RTV-641M30Y	VZ8-DL1M30Y	298	VW3-RZD1021	12

Power supply voltages

- Power according to tables.
- Field: U network 440V max. Choice of field voltage:
 - 0.9U network with fixed field supply,
 - 0.8U network with regulated field supply,
 - 0.5 or 0.8U network with field weakening (see page 6 for choice of motor).
 For the references S and Y (network 480 or 500V or 660V), supply the field and its control by means of a single-phase transformer with a 380V or 440V secondary.
 Transformer power: $P = I_{\text{field}} \times 1.10 \text{ secondary U}$ (for fixed field supply, consider I field at cold).
- Control: 440V max. network voltage.
 Control can be supplied separately from power (links CAL). It MUST be, when reference S or Y. Use a three-phase auto-transformer with a 220/240V or 380/415V or 440V secondary. Consumption of the control circuits: 70VA for all ratings except for ratings C18 and C27 with fan power supply: 250VA.
- Fans (see connections page 13).
 - ratings D16 to D72 : no fan
 - ratings C18 to C27 : fan supply with control: for 220V/240V, shunt the fan resistance on terminals 5-10 of connector J11 on the power interface board
 - ratings C40 and C65 : 1 fan 220V-50/60Hz - 185W - 0.85A
 - ratings C80 to M17 : 2 fans 220V-50/60Hz - 370W - 1.7A in total. Only 1 fan for RTV-541
 - rating M30 : 2 fans 380V-50/60Hz - 1100W - 2.4A at 50Hz in total
1580W - 2.9A at 60Hz in total

Definition of RECTIVAR 4

Selection guide

Selecting the speed controller rating

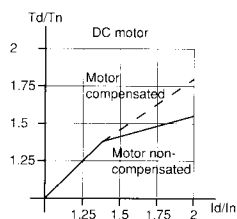

The table of pages 8 and 9 is used for determining the speed controller for:

- continuous duty operation,
- starting torque equal to 1.2 times the nominal motor torque.

For a cyclic operation, see below.

If the necessary starting torque is greater than 1.2 T_n, consider maximum current I_d absorbed by the motor to determine the speed controller:

- I_d must be ≤ the maximum permanent current of the speed controller.

To determine the maximum current I_d of the motor according to the starting torque, consult the curves of the machine or, if these are not available, the curves on the left.

E.g.: T_d/T_n = 1.6 motor non-compensated. The curves give I_d/I_n = 2.

I max. speed controller ≥ 2 I_n motor.

Operating modes

Permanent duty

The speed controller is characterized by maximum permanent current (I max.) which cannot be exceeded.

Standard cyclic operation

Operation can be defined by 2 currents I_o and I_p:

I_p = peak current,

I_o = steady state current = I_p/2

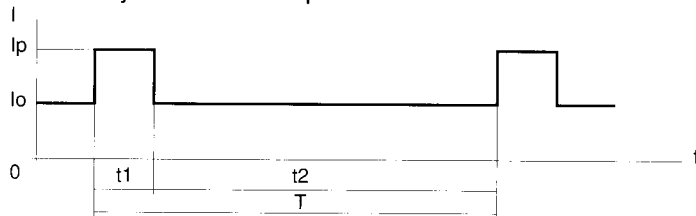

Observe the following time limits:

- t₂ ≥ 7 t₁,
- t₁ ≤ 15s for ratings from 16 to 650A,
- t₁ ≤ 10s for ratings from 800 to 3000A.

For I_o and I_p, the maximum values according to the ratings are as follows (in A):

Max. permanent current	16	32	48	72	180	270	400	650	800	1250	1750	3000	
I _o		11	22	34	50	125	175	260	425	520	750	1050	1800
I _p		22	44	68	100	250	350	520	850	1040	1500	2100	3600

Particular cyclic operation

For a particular and known operating cycle, calculate the average thermally equivalent current:

$$\text{Thermal current} = \sqrt{\frac{I_1^2 t_1 + I_2^2 t_2 + I_3^2 t_3 + \dots + I_n^2 t_n}{T}} \quad \text{with } T = t_1 + t_2 + t_3 + \dots + t_n$$

E.g.:

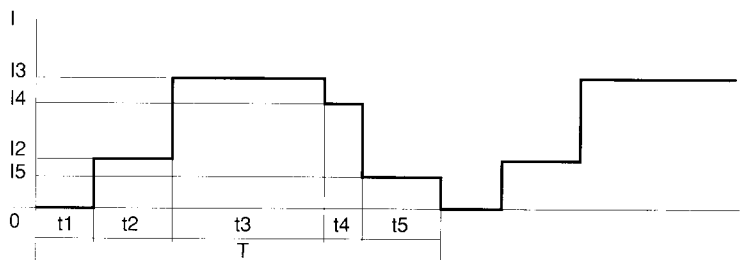

$$\text{Thermal current} = \sqrt{\frac{I_2^2 t_2 + I_3^2 t_3 + I_4^2 t_4 + I_5^2 t_5}{T}}$$

This thermal current must be ≤ 0.8 I max.

Check that the peak current due to the load is ≤ I_p.

Definition of **RECTIMAR 4**

Characteristics

Voltage, frequency of three-phase supply network	Maximum, 440V \pm 10% for D16, 500V \pm 10% for D32 to C65, 660V \pm 10% for C80 to M30, 50/60Hz \pm 2Hz.
Recommended armature voltage according to network voltage	U armature \leq U network x 1.05 for RTV-641. U armature \leq U network x 1.16 for RTV-541.
Field network voltage	Maximum voltage 440 V network - U field (see page 10).
Maximum field current	2A to 30A depending on speed controller rating (see pages 8-9).
Minimum field current detectable by safety devices	D16: 0.1A D32 to C65: 0.5A C80 to M30: 1A
Limitation of armature current	Adjustment on speed controller from Ip/3 to Ip. (Ip = peak current. See characteristics page 11).
Speed range	1 to 300 with tachogenerator. 1 to 20 with U feedback but accuracy depends upon motor.
Accuracy with variations: - of resistive torque 0.2 Cn to Cn - of the network voltage \pm 10% - for ambient temperature 20°C \pm 20°C	with tachogenerator: - 0.24% of the set speed - 0.066% of the maximum speed \pm 0.2% of the set speed \pm 1% of the set speed \pm 0.1% of the maximum speed
Speed reference: - by potentiometer - by analog signal - by signal current	Two voltage inputs \pm 10V 1 to 10k Ω connected to internal source 0 + 10V or 0 - 10V 0 to \pm 10V supplied by an external source (32k Ω input impedance) 0-20mA with 205 Ω input impedance 4-20mA with 254 Ω input impedance The \pm 10V inputs and the 0-20mA input are summed and isolated from the network.
Speed return by sensor or tachogenerator	5 setting positions: 10 - 22 - 45 - 90 - 180. For a U feedback, use with galvanic insulation board and link in position 10.
Acceleration and deceleration ramp	Separately adjustable acceleration and deceleration times from 0.5 to 60s in 2 ranges. Possibility of increasing the time (see page 48).
Reversing (RTV-641 only)	By external orders on logic inputs or by speed reference inversion. Reversing: 10ms dead band Operation in the four torque/speed quadrants.
Voltages and currents available on the speed controller (cumulative currents)	+ 15V (P15) or - 15V (N15), maximum current 30mA for all inputs (control, validation, display, regulation), option boards, all external functions. + 24V (PL), maximum current 50mA or 80mA if there is no current on the + 15V.
Logic inputs	RUN, LS, FW, RV: consumption 10mA, tripping threshold 12V minimum.
Contact maximum electric characteristics of output relays	250V AC on auxiliary contactor: inrush 300VA, sealed 30VA - 30 V DC: 0.5A max. Minimum switching capability: 24V/20mA, AC or DC. Number of manoeuvres: 10 ⁶ .
Degree of protection	IP00
Ambient temperature: - for operation - for storage	- 0°C to 40°C (operation possible up to 60°C by derating the current by 1.2% per additional °C) - -25°C to + 70°C
Derating according to altitude	Current derating by 0.7% per 100 m above 1000m.
Qualification standards	See three-phase RECTIMAR 4 catalogue, article 42081.

Definition of RECTIVAR 4

Connection terminals

Power bridge Ratings 32 to 3000A	AL1]	three-phase network supply - 50/60Hz
	AL2		
	AL3		
			earth
	M1 +]	motor armature
	M2 -		

The layout of the power terminals differs according to the ratings (see pages 26-27). In particular, the fans are supplied at the terminals mentioned below. Reminder: for ratings C18 and C27, the fans are supplied with the RECTIVAR control part.

- Ratings 400 and 650A (C40 and C65)
 - 0-220 separate fan supply
voltage 220V single-phase - 50/60Hz
power 185W - current: 0.85A
 - Ratings 800 to 1750A (C80 to M17)
 - 0-220 (RTV-541) fan supply
 - 0A-220A separate supply
 - 0B-220B for the two fans (RTV-641)
- | | | |
|--|---|--|
| |] | voltage 220V single-phase 50/60Hz
power per unit 185W
current: 0.85A |
| | | |
- 9-91 fuse contacts
 - 10-101 thermocontact
 - 207-208 contact GV1... line clipping fault (NO contact)
 - 205-206 contact GV1... line clipping fault (NC contact)
- Rating 3000A (M30, RTV-541 and RTV-641)
 - 0-380 ventilation presence module supply
- | | |
|------------|---|
| U1, V1, W1 | separate supply for 2 fans - 380V AC
power per unit: 550W in 50Hz, 790W in 60Hz
current per unit: 1.2A in 50Hz, 1.45A in 60Hz
i.e. for the 2 fans:
power: 1100W in 50Hz - 1580W in 60Hz
current: 2.4A in 50Hz - 2.9A in 60Hz |
| U2, V2, W2 | |
- | | |
|---------|----------------------|
| 9-91 | fuse contacts |
| 10-101 | ventilation presence |
| 203-204 | casing presence |

Separate module power terminals (ratings 800 to 3000A)	FL1]	single-phase supply of field supply bridge
	FL2		
			
	F1 +		positive output of field supply bridge
	F2 -		negative output of field supply bridge

Definition of RECTIVAR 4

Connection terminals

Power interface boards

There are three types of boards for the full range:

- rating 16A: board VX5-RLD101
- range 800 to 3000A: board VX5-RZD202
- range 32 to 650A: board VX5-RZD109

• Rating 16A

Name	P.J1	Function
CL1	1	control supply (***) absorbed current: 70mA
CL2	2	
CL3	3	
RNA	4	tachogenerator input
RNB	5	
K1A*	6	K1 relay voltage free contact with configurable function
K1B	7	
K2A*	8	K2 relay voltage free contact with configurable function
K2B	9	
FL1		single-phase supply of field supply bridge
FL2		
F1+		positive output of field supply bridge
F2-		negative output of field supply bridge
AL1		power bridge supply, 50/60Hz three-phase network
AL2		
AL3		
M1+		motor armature
M2-		

• Ratings 800 to 3000A

Name	P.J1	Function
CL1	1	control supply (***) - absorbed current: 70mA.
CL2	3	
CL3	5	
RNA	7	tachogenerator input
RNB	8	
FTA	9	+ 24V
FTB	10	sensor presence fault
PTE	11	+ 24V power supply (10mA max.)
NTE	12	- 24V power supply (10mA max.)
K2A*	13	K2 relay voltage free contact with configurable function
K2B	14	
K1A*	15	K1 relay voltage free contact with configurable function
K1B	16	
FC1	18	field control supply if the power and control supplies are dissociated - absorbed current: 70mA
FC2	20	

Definition of RECTIVAR 4

Connection terminals

Power interface boards

• Ratings 32 to 650A

Name	P.J1	Function	
CL1	1	control supply (***) - used if the control and power supplies are dissociated (U > 440V) - absorbed current: 70mA for 32, 48, 72, 400, 650A and 300mA for 180 and 270A (fan)]
CL2	2		
CL3	3		
RU	4	armature voltage output	
RNA	5	tachogenerator input]
RNB	6		
M1 +	7	armature voltage output	
FL1	8	single-phase supply of field supply bridge]
FL2	9		
F1 +	10	positive output of field supply bridge] screw terminals
F2 -	11	negative output of field supply bridge	
K1A*	12	K1 relay voltage free contact with configurable function]
K1B	13		
K2A*	14	K2 relay voltage free contact with configurable function]
K2B	15		
TTA**	16	(thermal trip contact), normally closed contact, voltage free, of the heat sink temperature probe (not connected to 32 and 72A ratings)]
TTB	17		
PTE	18	+ 24V power supply	
NTE	19	- 24V power supply	
NC	20	not connected	

* Contact maximum characteristics: see page 12.

** Probe contact maximum characteristics (from 180A on).

- Use: AC 250V inductive, inrush 300VA max., sealed 30VA max.
=DC inductive 30V, 0.5A max.

*** In the case of separate control supply, certain precautions need to be taken. See page 60.

Definition of RECTIVAR 4

Connection terminals

Control board	Name	C-J1	Function
	E1	1	speed reference input $0 \pm 10V$ ($32k\Omega$)
	0E1	2	0V of input E1
	E2	3	speed reference input $0 \pm 10V$ ($32k\Omega$)
	0E2	4	0V of input E2
	EC1	5	speed reference input 0-20mA (205Ω)
	0EC	6	0V of inputs EC1 and EC2
	EC2	7	speed reference input 4-20mA (254Ω)
	P10	8	reference potentiometer supply $+ 10V \pm 0.6V$ (10mA)
	N10	9	reference potentiometer supply $- 10V \pm 0.6V$ (10mA)
	ECL	10	(external current limit) input for 0-10V current limitation $R = 32k\Omega$ (see page 49)
	P15	11	supply $+ 15V \pm 0.6V$ maximum output 30mA without options
	N15	12	supply $- 15V \pm 0.6V$ maximum output 30mA without options
	0V	13	0V
	SAO	14	(speed amplifier output) max. current $\leq 5mA$
	CAI	15	current amplifier input ($100k\Omega$)
	PL	16	positive logic input supply (+24V)
	RUN	17	speed controller validation (gate circuits, loops, ramp) by PL
	SAD	18	auxiliary speed amplifier input for speed loop ($30k\Omega$)
	RO	19	ramp output (5mA)
	PL	20	positive logic input supply (+24V)
	ISI	21	(inhibition speed integration) suppression of speed amplifier integration by 0V
	DCC	22	current signal [0 to 10V for peak current (5mA)]
	SP	23	speed signal [0 to $\pm 8V$ for maximum adjusted speed (5mA)]
	IRT	24	increase ramp time by external voltage (see page 49)
	RZR	25	fast zero reset of ramp by 0V
	FW	26	forward
	RV	27	reverse] running direction, validation by PL
	PL	28	+24V
	0V	29	0V
	LS	30	(low speed) devalidation of internal low speed by PL
	AT	31	assignable terminal connected to + 24V by factory wiring (see terminal block J5 on the next page)
	FF	32	field fault
	SF	33	network fault

Use of terminals: see pages 46 to 52.

Definition of RECTIMAR 4

Connection terminals

Specific uses

Terminal block option J5

The data on terminal block J5 is reserved for use with option boards

Name	J5	Function
SMA	01	speed reference presence detector input
SM	02	reference summing output
SRC	03	"speed reference generation" circuit output
RIN	04	speed ramp input
RO	05	speed ramp output
SAI	06	speed amplifier input
SAO	07	speed amplifier output
CAI	08	current amplifier input
CAO	09	current amplifier output
IGI	10	0-10V analogue signal gate circuit control input
FS	11	"fault" information output
CRA	12	relay K1 control
VA	13	gate circuit validation (output)
IHL	14	gate circuit validation logic input by control logic (or by brake logic with option)
ODM	15] control logic output
ODM	16	
CRB	17	relay K2 control
DLIM	18	current limitation operating detection
SNO	19	zero speed information (zero speed = 1)
ISI	20	integration validation (shunt by 0V)
SNO	21	19's complement (zero speed = 0)
VLI	22	reversal logic validation; reversal not possible if VLI = 0
PL	23	positive logic: + 24V
AT	24	assignable terminal connected to terminal AT of customer terminal block (C.J1-31)
ODM	1] control logic output
ODM	2	
SI	3	
SAD	4	
RZR	5	
RTU	6	
VNF	31	- 24V
N15	32	- 15V
0	33	0V
P15	34	+ 15V
DVA1	35	state of bridge 1
DVA2	36	state of bridge 2
VSI	37	current loop validation input
SP	38	speed signal; analogue signal $\pm 8V$ for N max.
DSE	39	speed error sign detector output
CA1	40] locking by 0V
CA2	41	
CSI	42	reversal logic output for validation of current loop
ODM	43	control logic output
RTU	44	voltage feedback if galvanic insulation is fitted to power interface board
SRIE	45	field current reference signal
SIE	46	field current signal
	47] do not use
	48	

Terminals 1 to 24 are used for personalise the product (see page 19)

Controlled field and control board links, ratings $\geq C80$

field board (VX4-RZD104)

J51-1
J51-2
J51-3
J51-4
J51-5
J51-6

control board (VX4-RZD303)

0V J5-33
SP J5-38
ODM J5-43
RTU J5-44
SRIE J5-45
SIE J5-46

Definition of RECTIVAR 4

Connection terminals

Specific uses

The table of the next page gives examples of different speed controller configurations corresponding to the application:

1 - The table represents the wiring of the product as it leaves the factory. Relay K1 is controlled when the gate circuits are validated (motor energized).

Relay K2 is operated when the speed controller is in speed control mode (current limitation is not affected).

2 - Relay K1 is operated when the speed controller is not in "fault" condition.

Relay K2 is operated when the speed controller is in speed control mode.

3 - Relay K1 is operated when the speed controller is not in "fault" condition.

Relay K2 is operated when the motor speed is between 2 and 100 % of the maximum speed (detection of non-zero speed).

4 - Relay K1 is operated when the gate circuits are validated.

Relay K2 is operated when the motor speed is between 2 and 100 % of the maximum speed.

5 - The movement order is supplied by the presence of the reference with configuration of the relays identical to those of column 1.

6 - For RTV-641 only.

Operation in 2 quadrants only. Bridge reversal takes place when the speed is zero. The relay configuration is identical to that of column 1.

7 - Integration by pass at zero speed.

Avoids speed drift near the stopping point.

Relay K1 is operated when the gate circuits are validated (the motor is energized).

Relay K2 is operated when the speed controller is in speed control mode (current limitation is not affected).

8 - For RTV-641 only.

Servo control of a brake control for exclusively horizontal movements.

Relay K1 is operated when the gate circuits are validated.

Relay K2 is operated when an operating order is given and the motor speed is between 2 % and 100 % of the maximum speed.

Note: for vertical movements, use the option board VW2-RLD310.

Definition of RECTIVAR 4

Connection terminals
Specific uses

Examples
of applications

Name	J5	1	2	3	4	5	6	7	8	9
AT	24									
PL	23									
VLI	22									
$\overline{\text{SNO}}$	21									
ISI	20									
SNO	19									
DLIM	18									
CRB	17									
ODM	16									
ODM	15									
IHL	14									
VA	13									
CRA	12									
FS	11									
IGI	10									
CAO	09									
CAI	08									
SAO	07									
SAI	06									
RO	05									
RIN	04									
SRC	03									
SM	02									
SMA	01									

The speed controller is supplied with the option terminal block in configuration 1. Other uses are available (see page 18). To make the adaptations, the product is supplied with one 12 pin connector and 15 straps.

— direct link between end terminals

For all different wiring of 1, memorize the configuration by filling in the customization label included with the Rectivar.

Installation of RECTIVAR 4

Precautions

Reception of speed controller

When unpacking the speed controller, check it has not been damaged during transport. Make sure that the speed controller reference on the label, affixed on the left side, conforms to the delivery note corresponding to the purchase order and to the correspondence table (page 10) for ratings C80 • to M30 •.

It is recommended to carry the speed controller in a horizontal position or by using the lifting rings (ratings 400 to 3000A). However, they can be stood vertically on the floor except for 800 to 1750A ratings.



If the speed controller has been stored or switched for several months, turn the rotor of any fans fitted over by hand.

Climatic environment

For temperature and ambient humidity, altitude, vibrations and shocks, degree of protection, see the characteristics in the three-phase Rectivar catalog No. 42081.

Protect the speed controller against dust, in particular conductive dust, corrosive gases and splashing liquids.



In the event of danger of condensation:

if the equipment is switched for periods of more than one hour, provide for a heating system (0.2 to 0.5W per square decimeter of casing), connected automatically as soon as the equipment stops. This device will maintain the inside of the casing at a temperature slightly higher than the outside temperature thus avoiding any risks of condensation and dripping water. The natural heating of energized equipment is sufficient to initiate this temperature difference.

Mounting precautions

Mount the unit vertically so that the air circulates from bottom to top in the heat sink fins. Keep away from heating elements.

If the equipment is to be mounted in a rack, provide louvers for cooling air flow and when forced ventilation is used, an opening in the top should be provided, with a protective cover and, if necessary, inlet filters.

Mounting in a metal enclosure

Degree of protection IP23.

To insure good air circulation through the product:

- leave sufficient space around the speed controller:
 - $d \geq 50\text{mm}$,
 - $D \geq 100\text{mm}$,
- provide ventilation louvers.

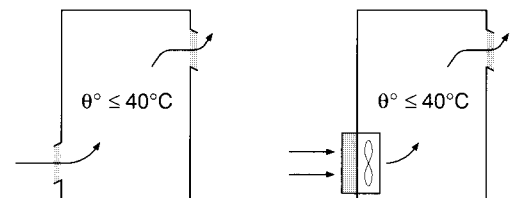
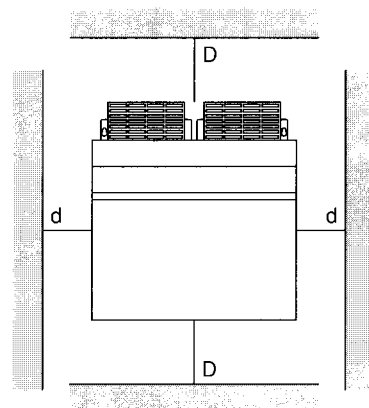

- fan flows:

- 180 and 270A bridges : 360m³/h
- 400 and 650A bridges : 1300m³/h
- 800 to 1750A bridges : 2600m³/h for RTV-641
1300m³/h for RTV-541
- 3000A bridge: 3600m³/h

Installation of RECTIVAR 4

Precautions

Mounting in a metal enclosure

- power to be evacuated:

Type of bridge	Power	Type of bridge	Power
A	W	A	W
16	110	400	1200
32	150	650	2000
48	200	800	2400
72	270	1250	3710
180	600	1750	5250
270	850	3000	9000

Mounting in dust and damp protected enclosure

Degree of protection IP54.

Fit a heat exchange device to dissipate the power dispersed in the enclosure.

See the dissipated power table.

Wiring

• Insulation

Except for the terminals marked \perp reserved for earth, do not connect any of the conductors connected to the terminal blocks to earth or to the installation earth.

• External circuits for speed reference and feedback (for tachogenerator) must be wiring using twisted wires (pitch ≥ 5 cm).

Separate the power cable and control wires as much as possible.

The information across the following terminals must be wired as described below.

Control board terminal block J1

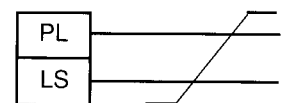
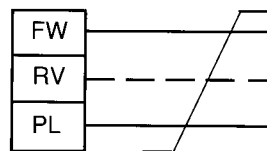
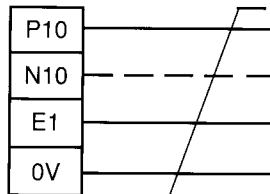

Power interface board terminal block J1

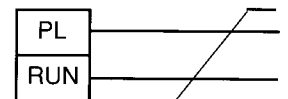

The other signals accessible on the customer terminal block must be wired by twisted wires (pitch ≤ 5 cm) and screened (screening connected to product earth). The maximum length of the interconnection will be 5m. Beyond this, provide for an interface circuit.

Installation of RECTIVAR 4

Dimensions and weights

RECTIVAR 16 to 180A

Fixings: 4 x Ø 6.5

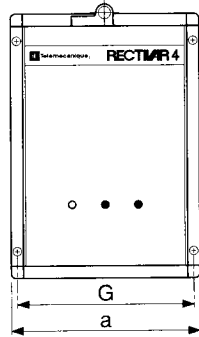
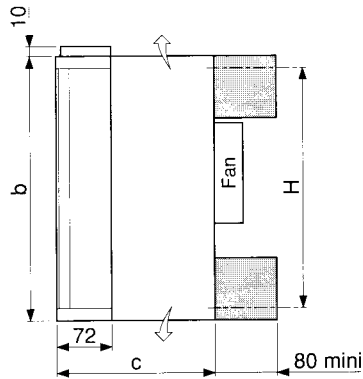

RECTIVAR 270A

Fixings: 4 x Ø 6.5

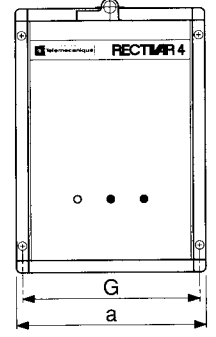
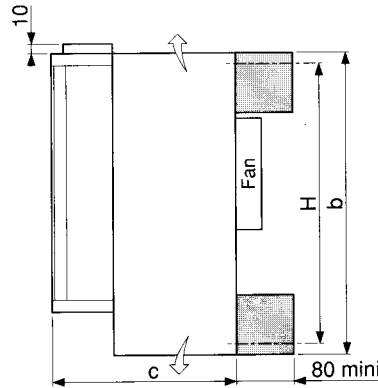

 Cooling spacers for assembly on a flat surface (ratings C18 and C27).
Assembly ref. VY1-RZD102 to be ordered separately.

Rectivar	Dimensions			Fixings			Weight kg
	a	b	c	H	G	Ø	
RTV-641D16Q	231	323	168	290	200	6.5	5.5
RTV-541/641D32	231	323	220	290	200	6.5	6.5
RTV-541/641D48	231	323	260	290	200	6.5	10
RTV-541/641D72	231	323	260	290	200	6.5	10
RTV-541/641C18	231	323	260 + (80)*	290	200	6.5	11
RTV-541/641C27	231	403	260 + (80)*	370	200	6.5	13

RECTIVAR 400 and 650A

RTV - 541/641 C40• and C65•

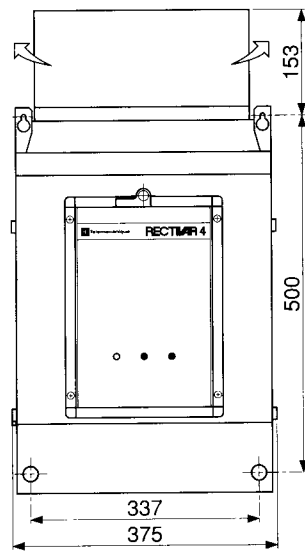
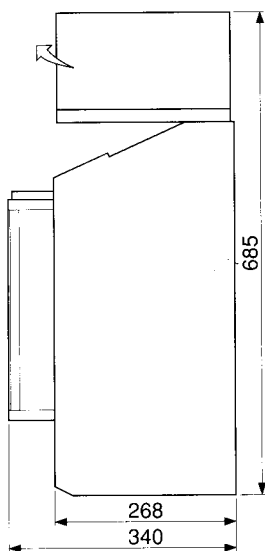

Weight: 47 kg

Fixings: 4 x Ø8.5

Control module VW3-RZD1021

RTV - 541/641 C80• to M30•

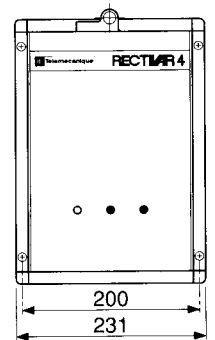
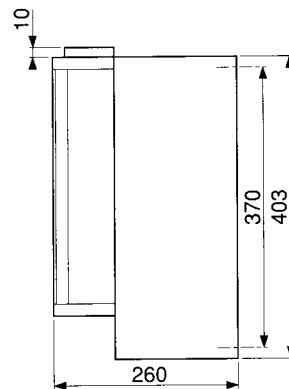

Weight: 12 kg

Fixings: 4 x Ø 6.5

Installation of RECTIVAR 4

Dimensions and weights

RECTIVAR 800 to 1750A, power bridge: RTV-641C80• to M17•

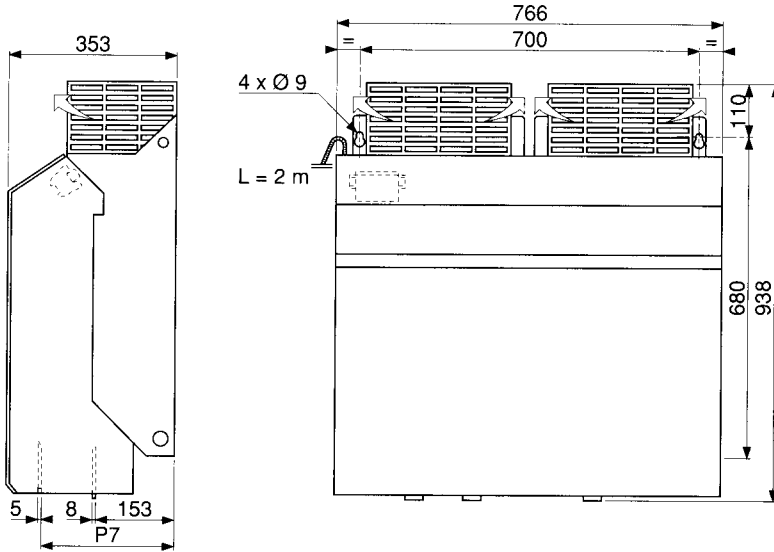

Rectivar	P7	Weight (kg)
RTV-641C80• to M12•	270	108
RTV-641M17•	278	120

power bridge: RTV-541C80• to M17•

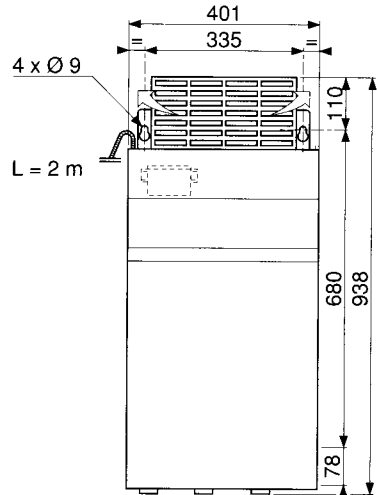

Rectivar	P7	Weight (kg)
RTV-541C80• to M12•	270	54
RTV-541M17•	278	60

RECTIVAR 3000A, power bridge: RTV-541M30•
RTV-641M30•

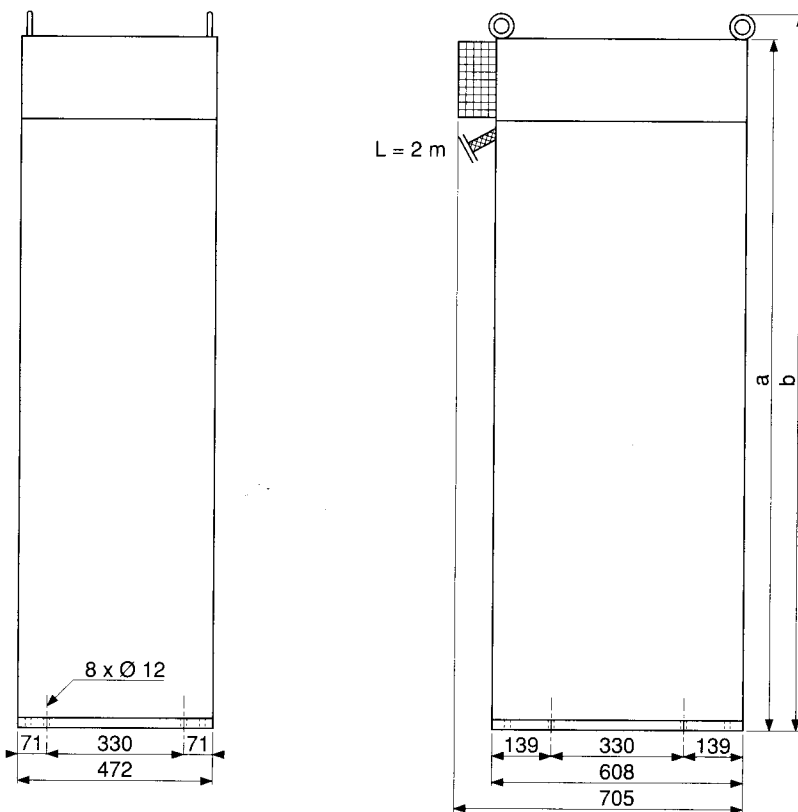

floor mounting
viewed from A

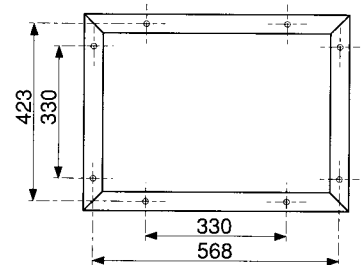

	a	b	Weight (kg)
RTV-541	1330	1400	220
RTV-641	1670	1740	298

A
↑

Installation of RECTIVAR 4

Dimensions and weights

Three-phase line inductances

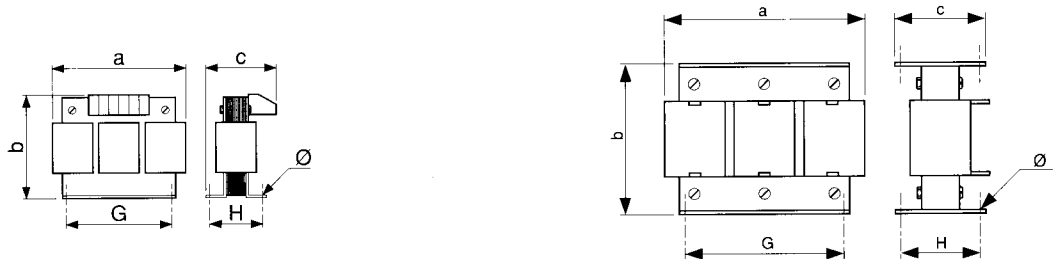

Reference	a	b	c	G	H	Ø	Weight (kg)
VZ1-L015UM17T	155	145	100	94	52	5.5	2.700
VZ1-L030U800T	190	180	120	136	71	5.5	4.700
VZ1-L040U600T	190	180	145	136	83	5.5	5.900
VZ1-L070U350T	230	215	150	166	95	5.5	10.00

VZ1-L150U170T	300	240	170	226	100	6.5	16
VZ1-L250U100T	300	240	210	226	126	8.5	22
VZ1-L325U075T	300	240	250	226	156	10.5	32
VZ1-L530U045T	420	410	230	310	95	8.5	40
VZ1-L650U038T	420	410	280	310	105	8.5	50
VZ1-LM10U024T	420	410	320	310	135	8.5	72
VZ1-LM14U016T	420	490	350	310	135	8.5	86
VZ1-LM24U010T	420	550	395	310	165	8.5	128

Association with speed controller: see page 69.

Power terminal protection cover

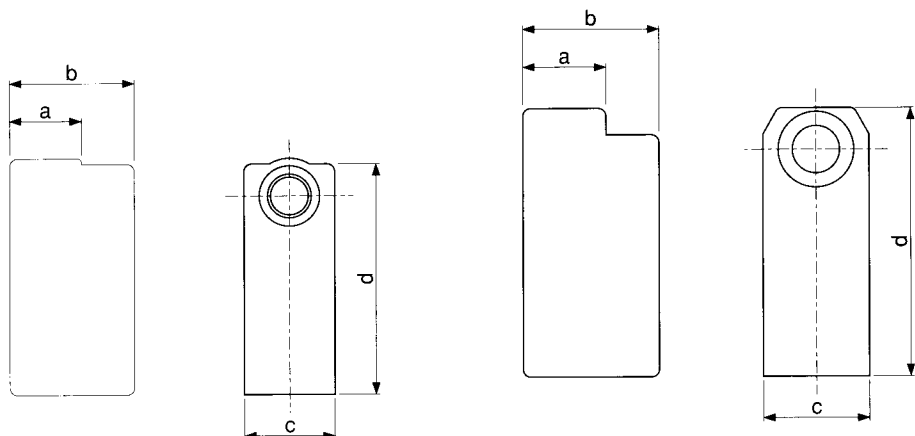

LA9-F701

LA9-F702/703/704

Reference	a	b	c	d	Speed controller
LA9-F701	26	43	26	72	RTV-541/641 32 to 180A, VW3-RZD1021
LA9-F702	27	48	34	90	RTV-541/641 270A (~)
LA9-F703	35	58	45	112	RTV-541/641 270A (=), 400A, 650A (~)
LA9-F704	40	72	64	120	RTV-541/641 650A (=)

Installation of RECTIVAR 4

Dimensions and weights

Fuses

Association with speed controller
(page 69)

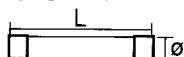

Reference	L	Ø
DF3-EF04001	51	14
DF3-FF05002	58	22
DF3-FF10001	58	22

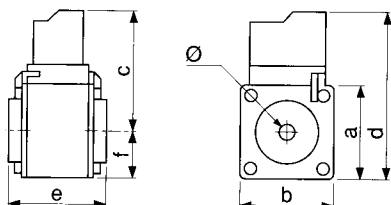

Reference	a	b	c	d	e	f	Ø
DF3-NF25002	51	51	67	92	51	25.5	8
DF3-NF40002	51	51	67	92	51	25.5	8
DF3-NF50002	51	51	67	92	51	25.5	8
DF3-QF80002	75	75	79	116	51	37.5	12

For DF3-NF25002 to DF3-QF80002 fuses use:
- one fuse contact VZ1-P001

Fuse carriers

Fuses size 14-51, 22-58:
carriers DF5-EA and FA.

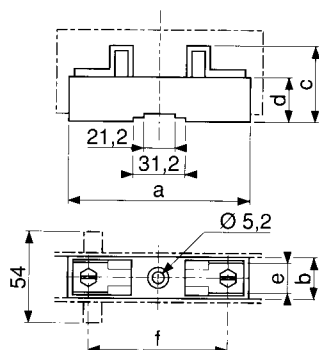

Reference	Size	a	b	c	d	e	f
DF5-EA61	14-51	105	22	48	24	17	85
DF5-FA61	22-58	115	30	55	24	23	90

- Carriers for fuses type DF3-NF to QF, to be used when wiring is not made by coppers bars.
(If not, fuses can be fixed to bars).

WARNING

respect the creepage distances between fuses.

E.g.: NFC 20.040

Reference	Fuse	a	b	Ø
DF5-NZ01	DF3-NF25002	157	90	8
DF5-NZ01	DF3-NF40002	157	90	8
DF5-NZ01	DF3-NF50002	157	90	8
DF5-QZ01	DF3-QF80002	181	102	12

Width of plate: 47.

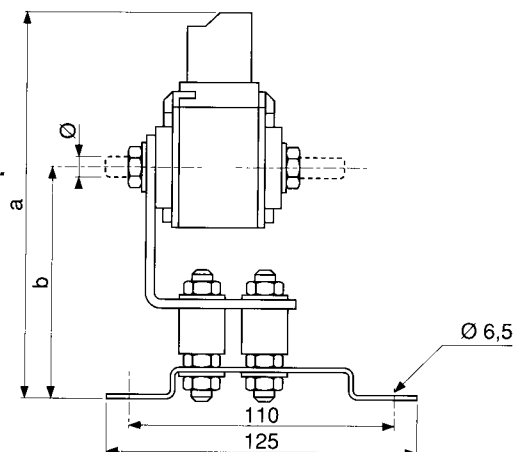

Installation of RECTIVAR 4

Power connections

RECTIVAR 16A

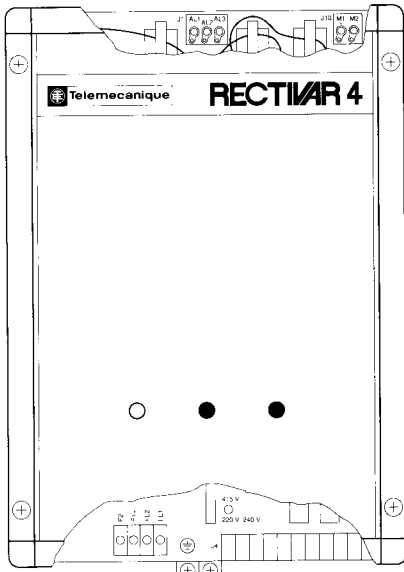

RECTIVAR 32 to 180A

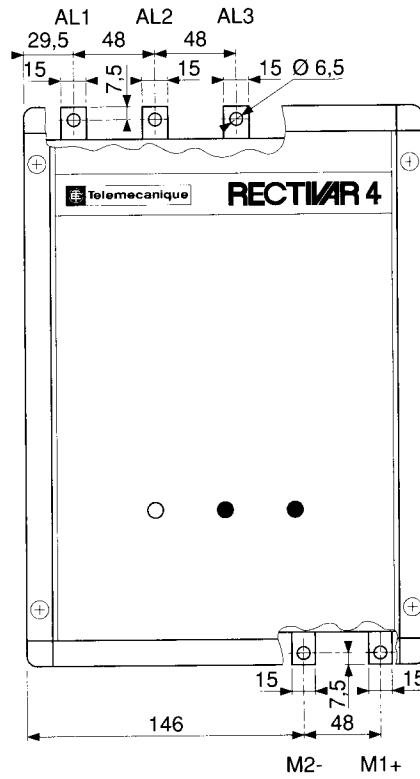

RECTIVAR 270A

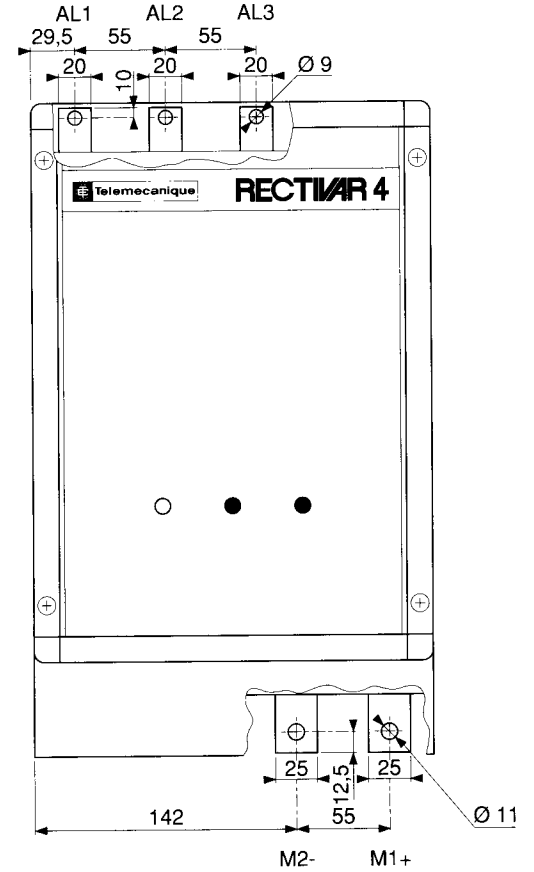

Ratings 180 and 270A: for 220V, shunt resistance RH on pins 5 and 10 of connector J11 on the power interface board.

RECTIVAR 400 to 650A

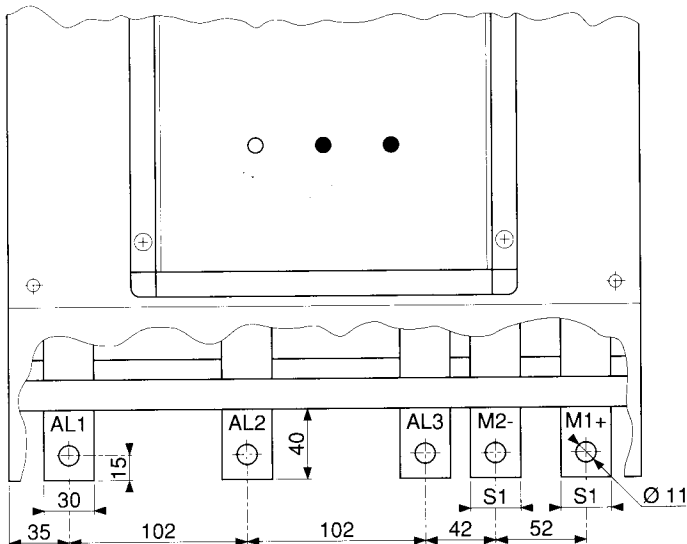

	RTV-541/641C40	RTV-541/641C65
S1	30	40

Ratings 400 and 650A: fans connected to terminals 0-220.

Installation of RECTIVAR 4

Power connections

Control module
VW3-RZD1021

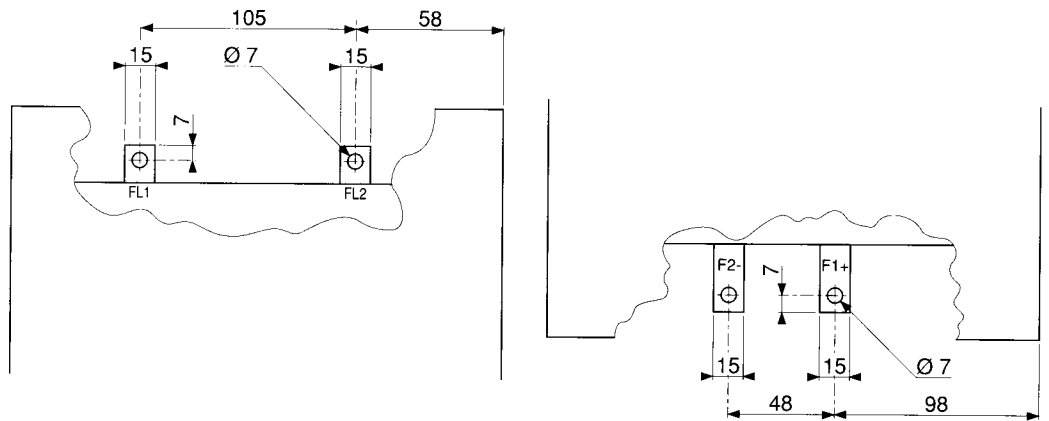

RECTIVAR 800 to
1750A

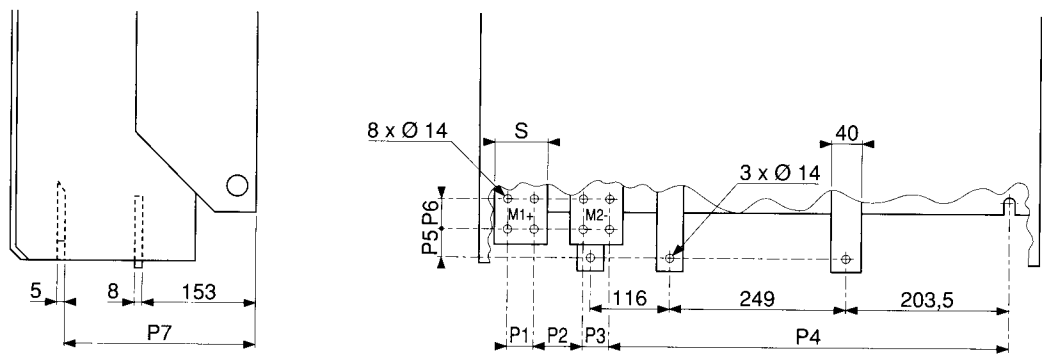

RECTIVAR	P1	P2	P3	P4		P5	P6	P7	S
				RTV-641	RTV-541				
RTV-541/641C80• to M12•	26	94	26	516	151	86.5	26	270	63
RTV-541/641M17•	40	80	40	529	164	89.5	40	278	80

RECTIVAR 3000A

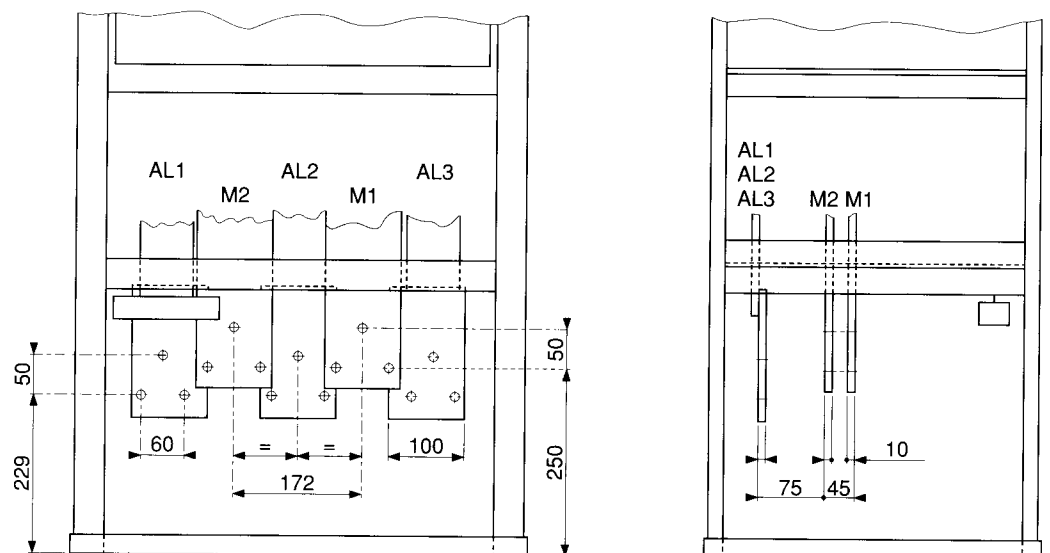

Installation of RECTIVAR 4

Component layout RECTIVAR RTV-541

Power bridge 32 to 180A

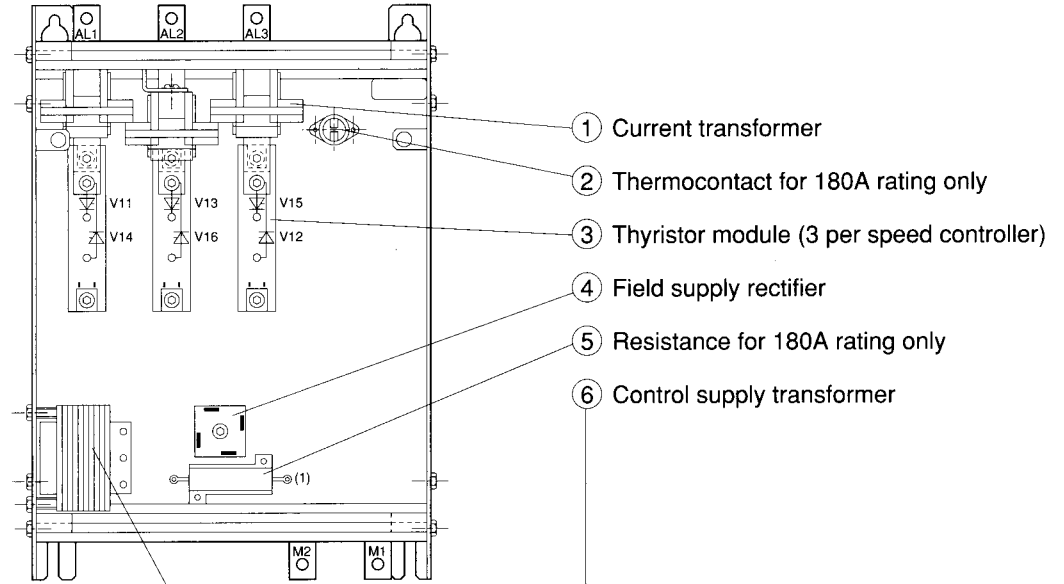

Internal wiring

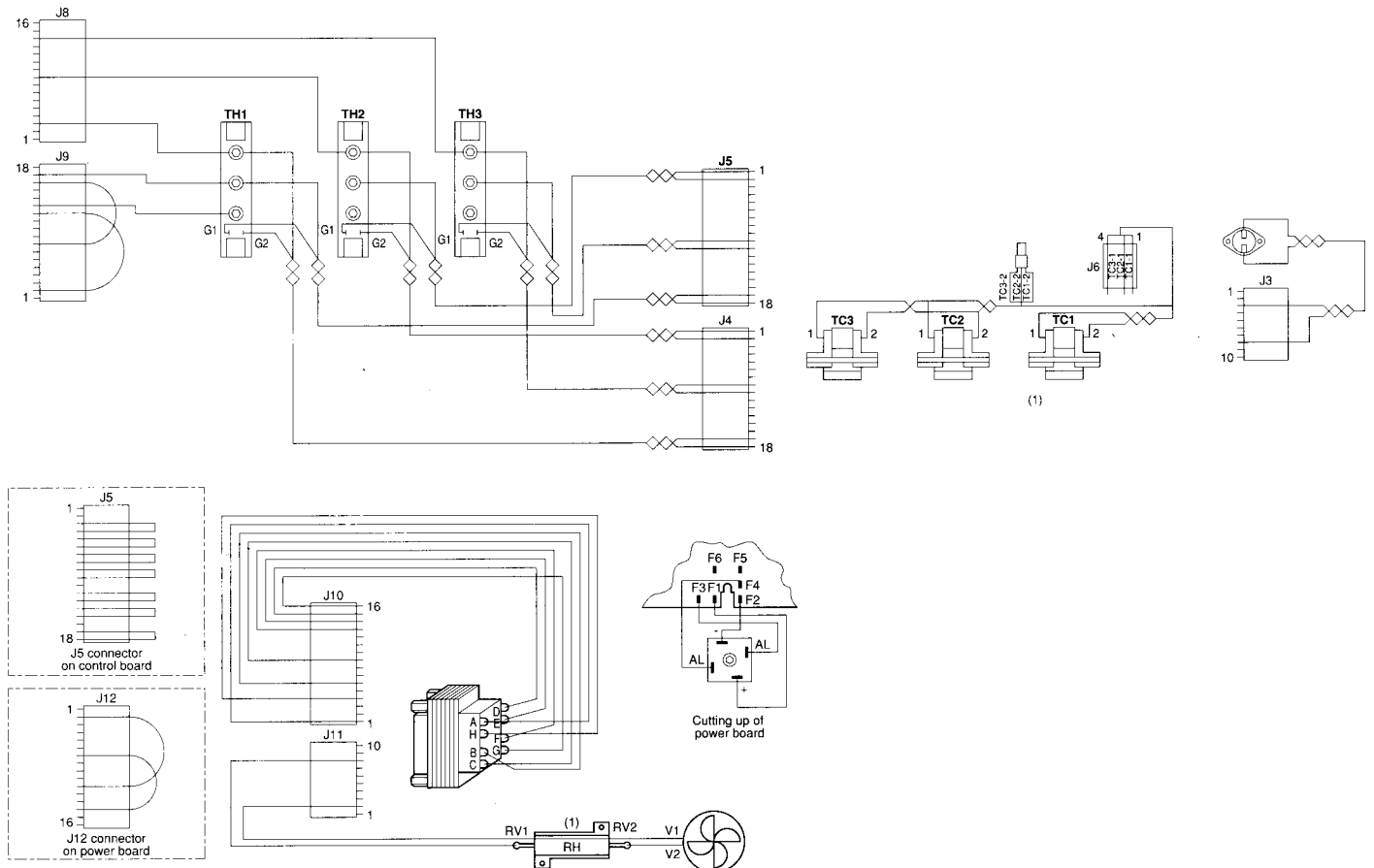

(1) Rating 180A: for 220V, shunt resistance RH on pins 5 and 10 of connector J11 on the power interface board.

Installation of RECTIVAR 4

Component layout RECTIVAR RTV-541

Power bridge 270 to 650A

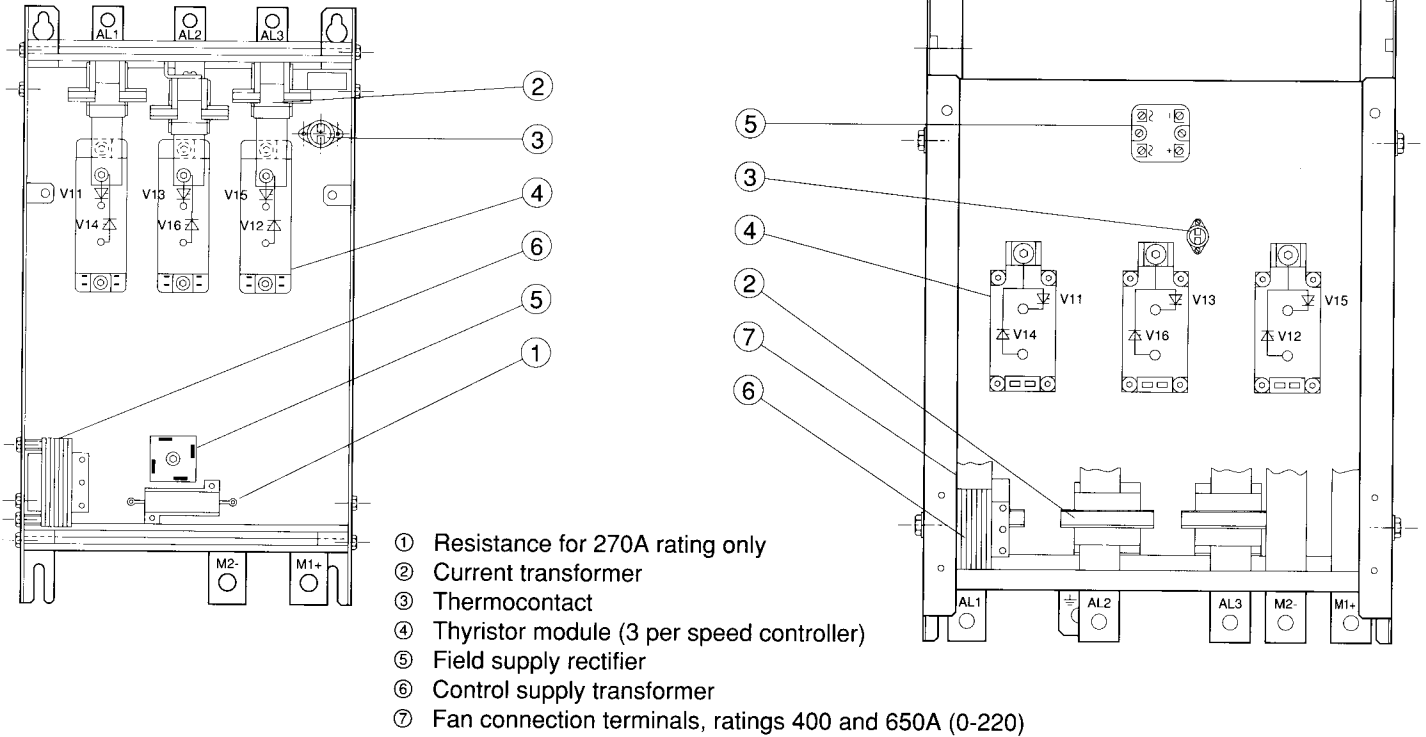

Internal wiring

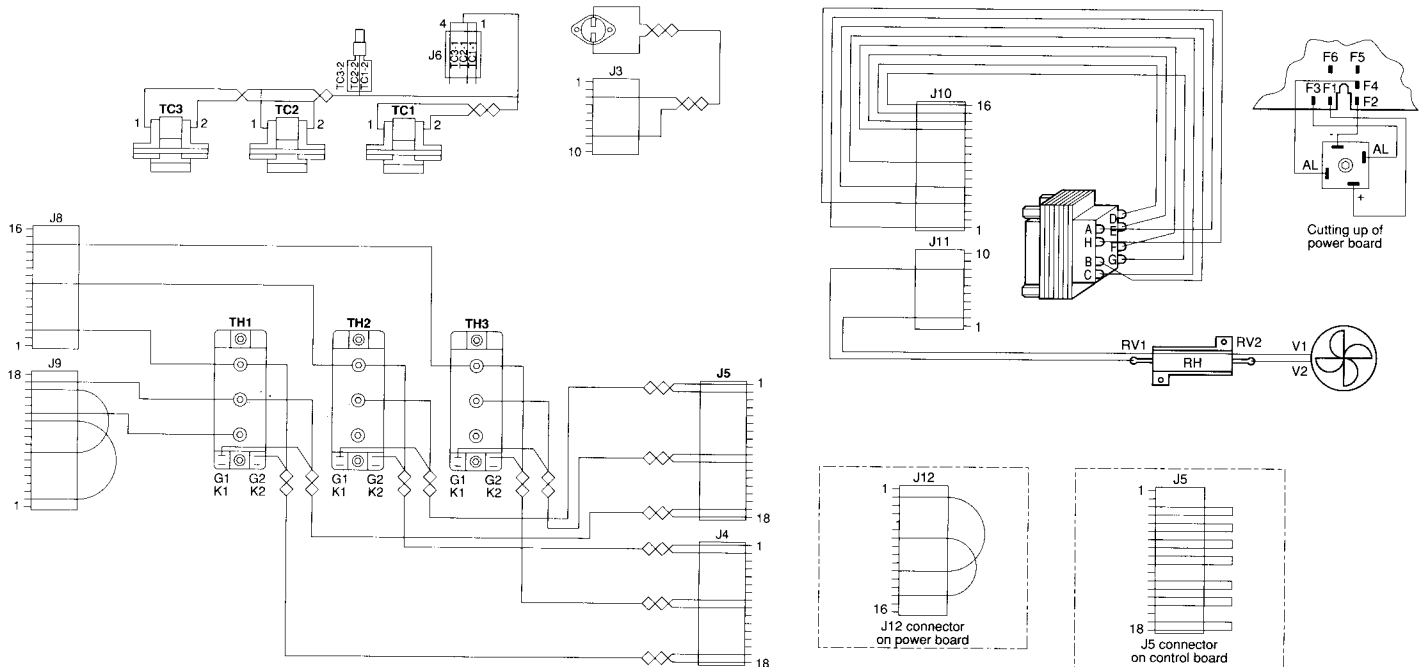

Ratings 400 and 650A: fans connected to terminals 0-220.

Rating 270A: for 220V, shunt resistance RH on pins 5 and 10 of connector J11 on the power interface board.

Installation of RECTIVAR 4

Component layout RECTIVAR RTV-541

Power bridge
800 to 1750A

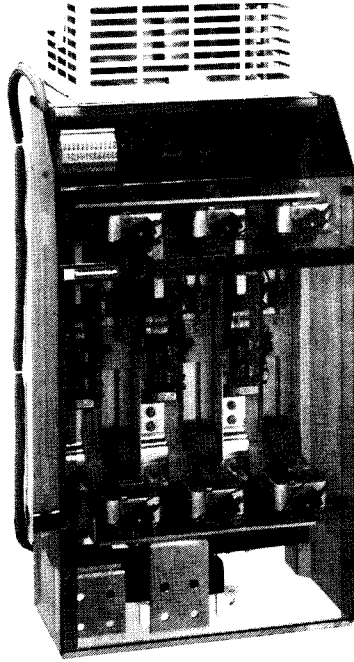

Internal wiring

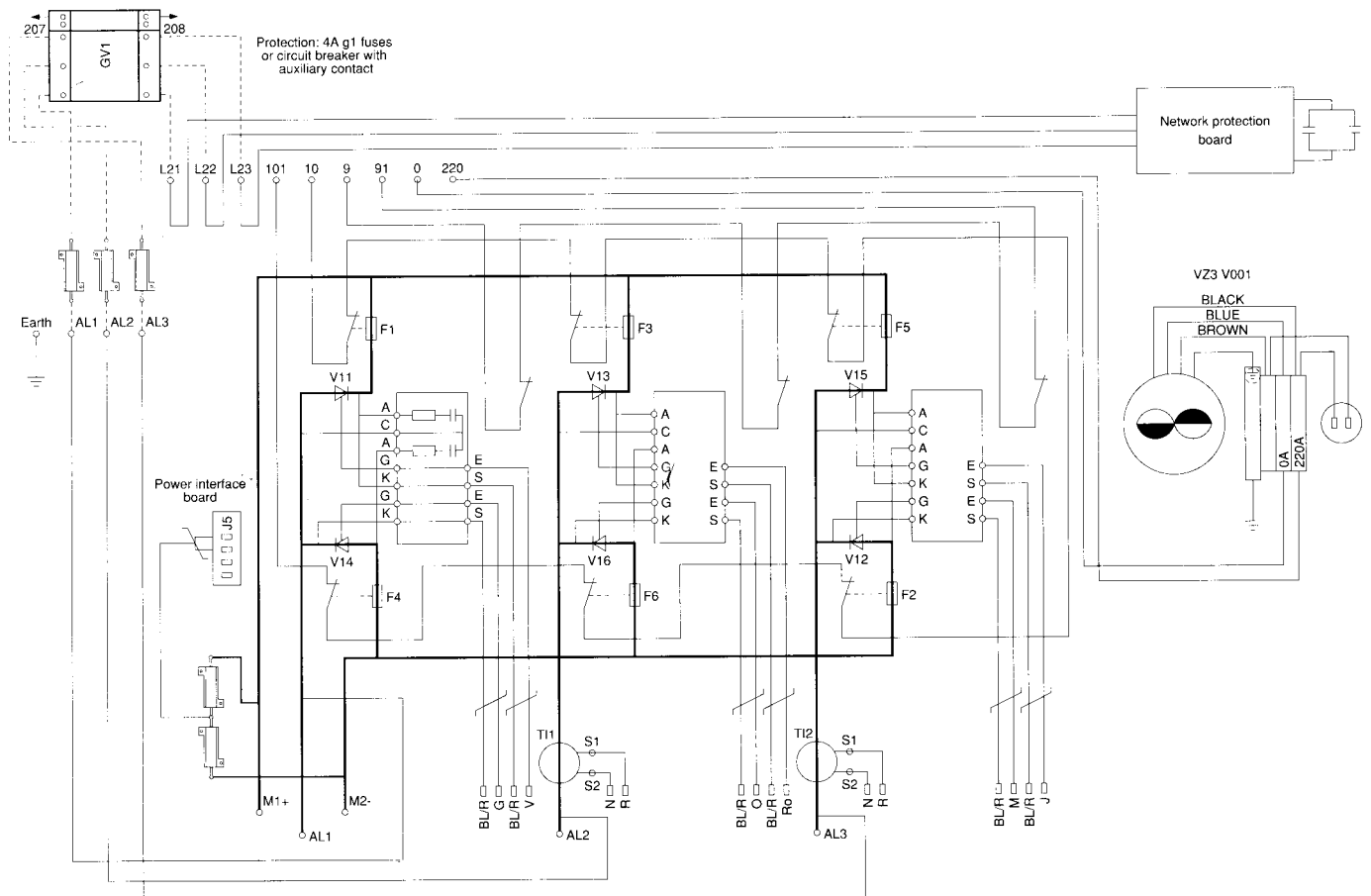

Installation of RECTIVAR 4

Component layout
RECTIVAR RTV-541

Power bridge 3000A

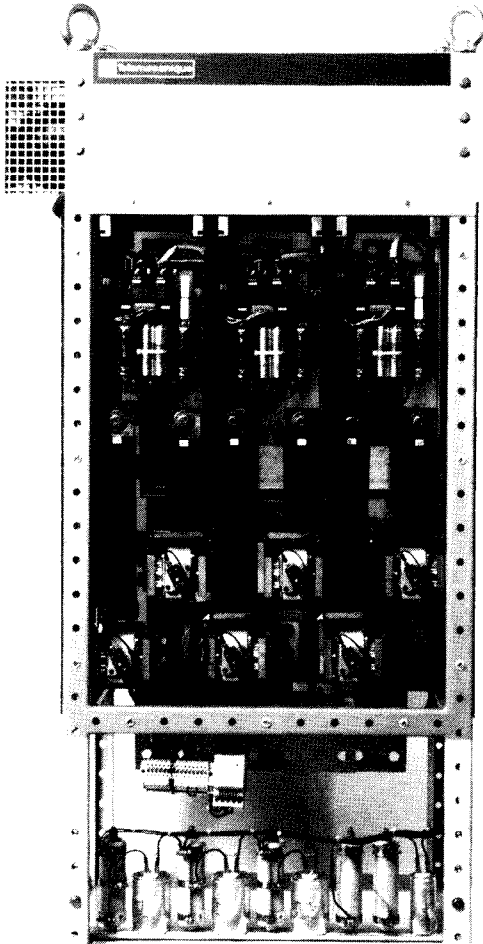

Internal wiring

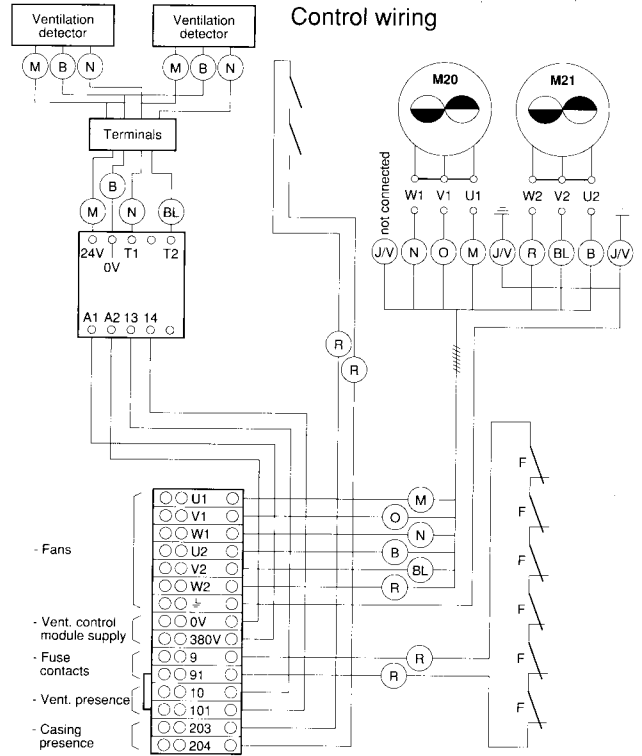

Firing gate wiring

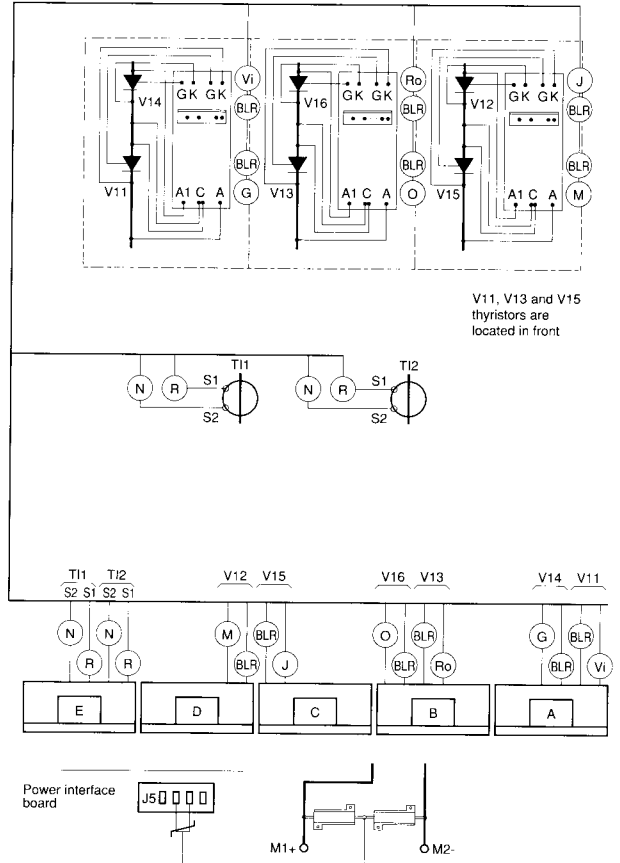

Installation of RECTIVAR 4

Component layout RECTIVAR RTV-641

Power bridge 32 to 180A

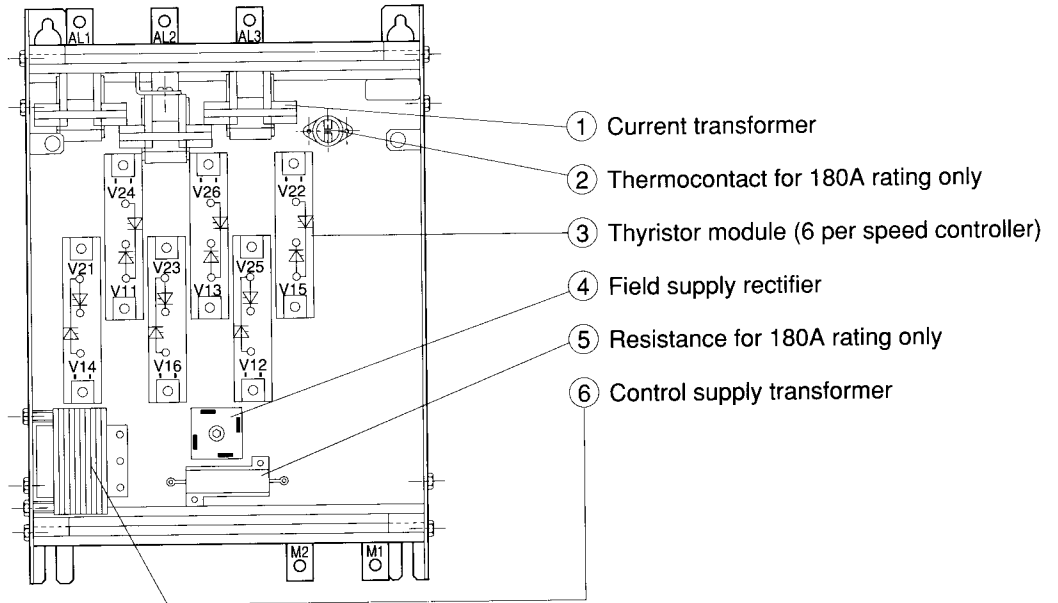

Internal wiring

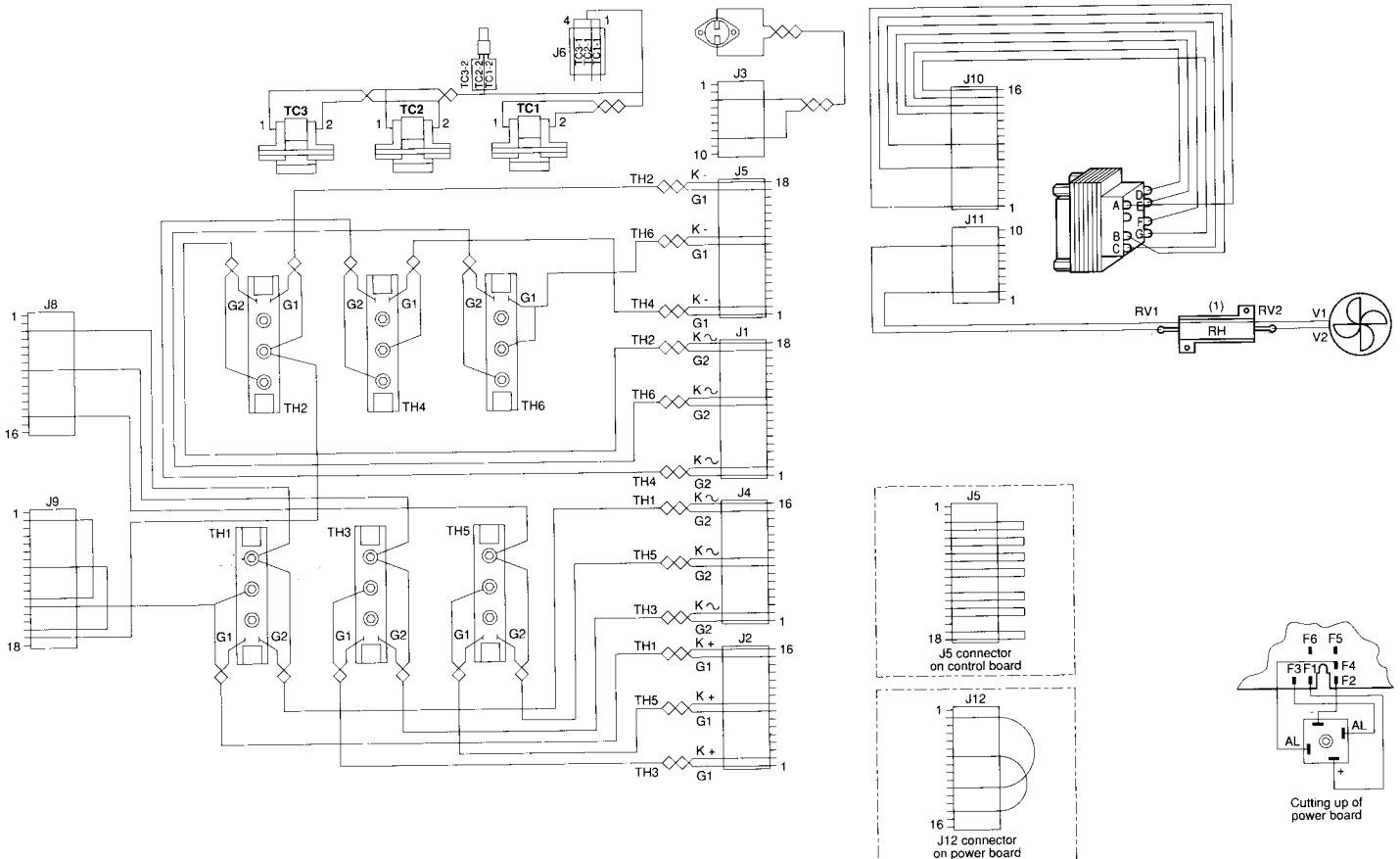

(1) Rating 180A: for 220V, shunt resistance RH on pins 5 and 10 of connector J11 on the power interface board.

Installation of RECTIVAR 4

Component layout RECTIVAR RTV-641

Power bridge 270 to 650A

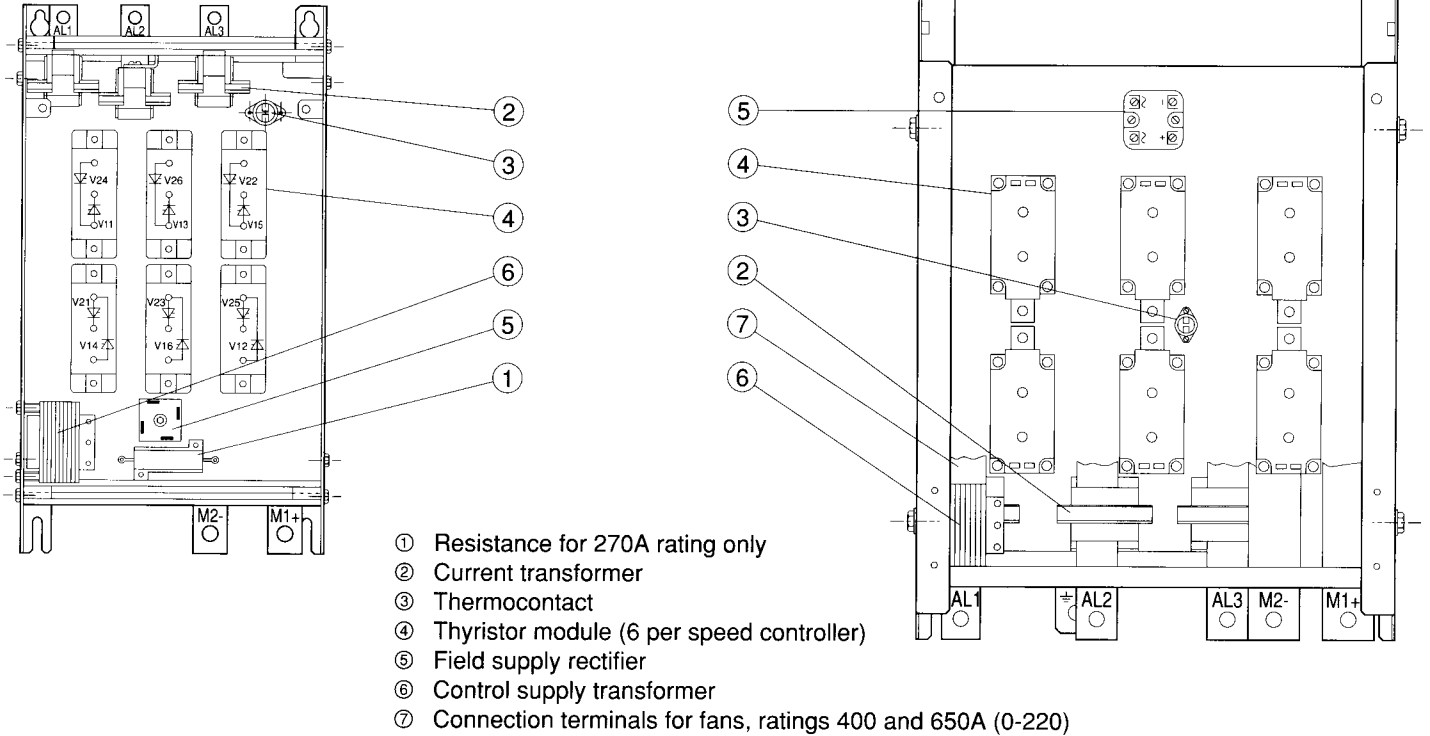

Internal wiring

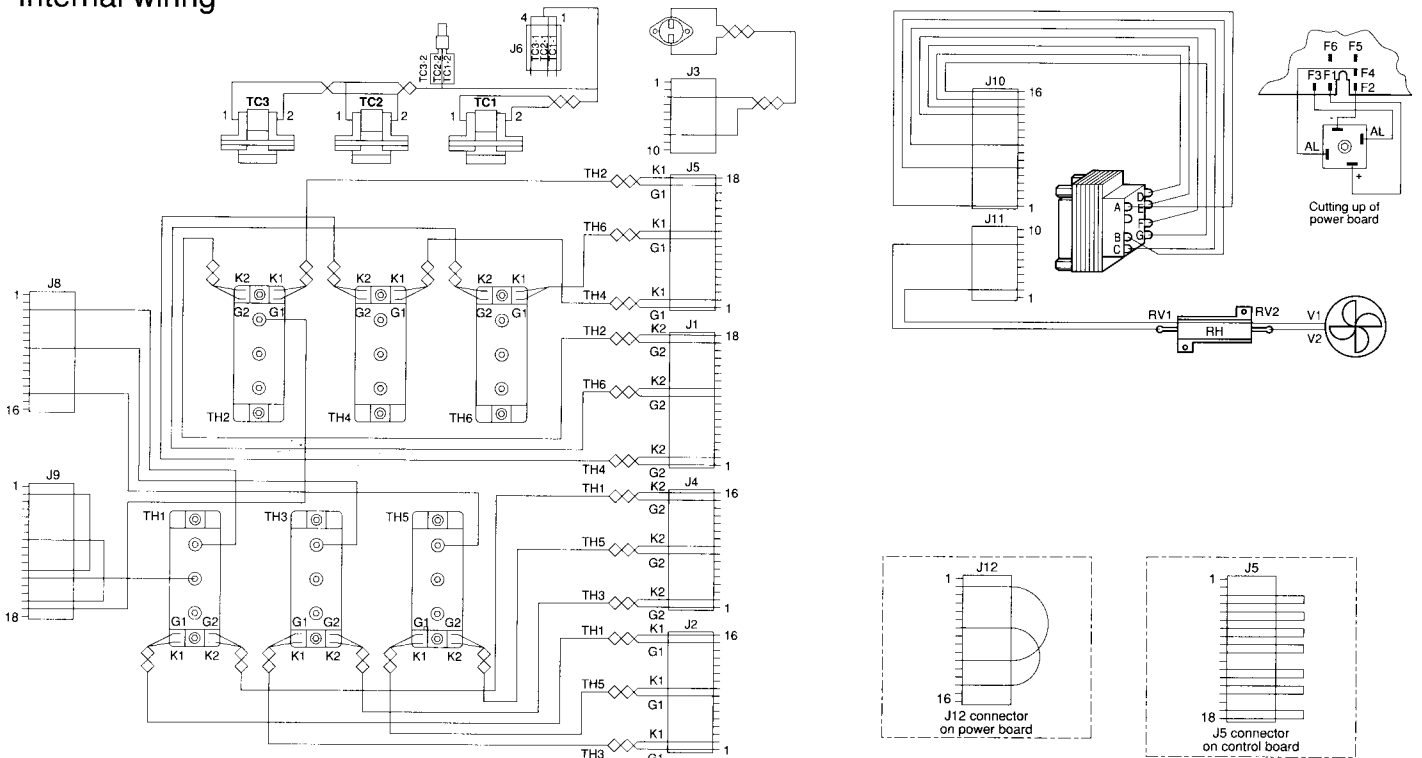

Ratings 400 and 650A: fans connected to terminals 0-220.

Rating 270A: for 220V, shunt resistance RH on pins 5 and 10 of connector J11 on the power interface board.

Installation of RECTIVAR 4

Component layout
RECTIVAR RTV-641

Power bridge
800 to 1750A

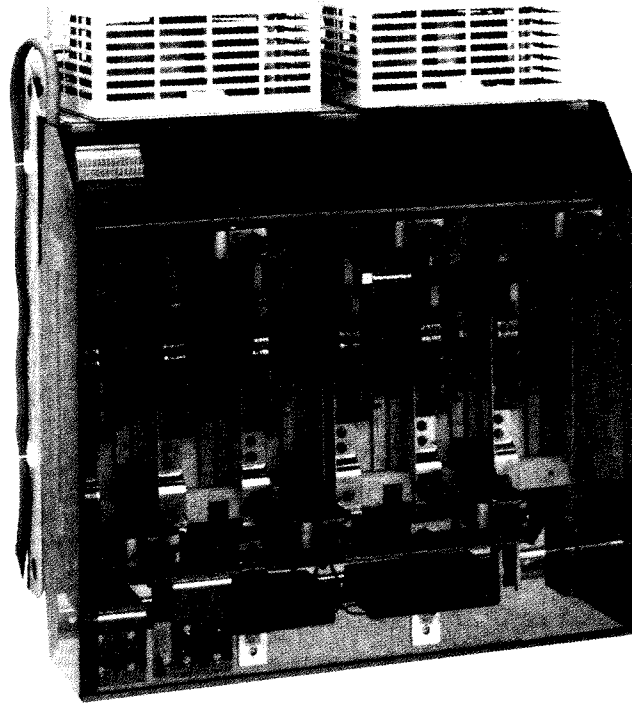

Internal wiring

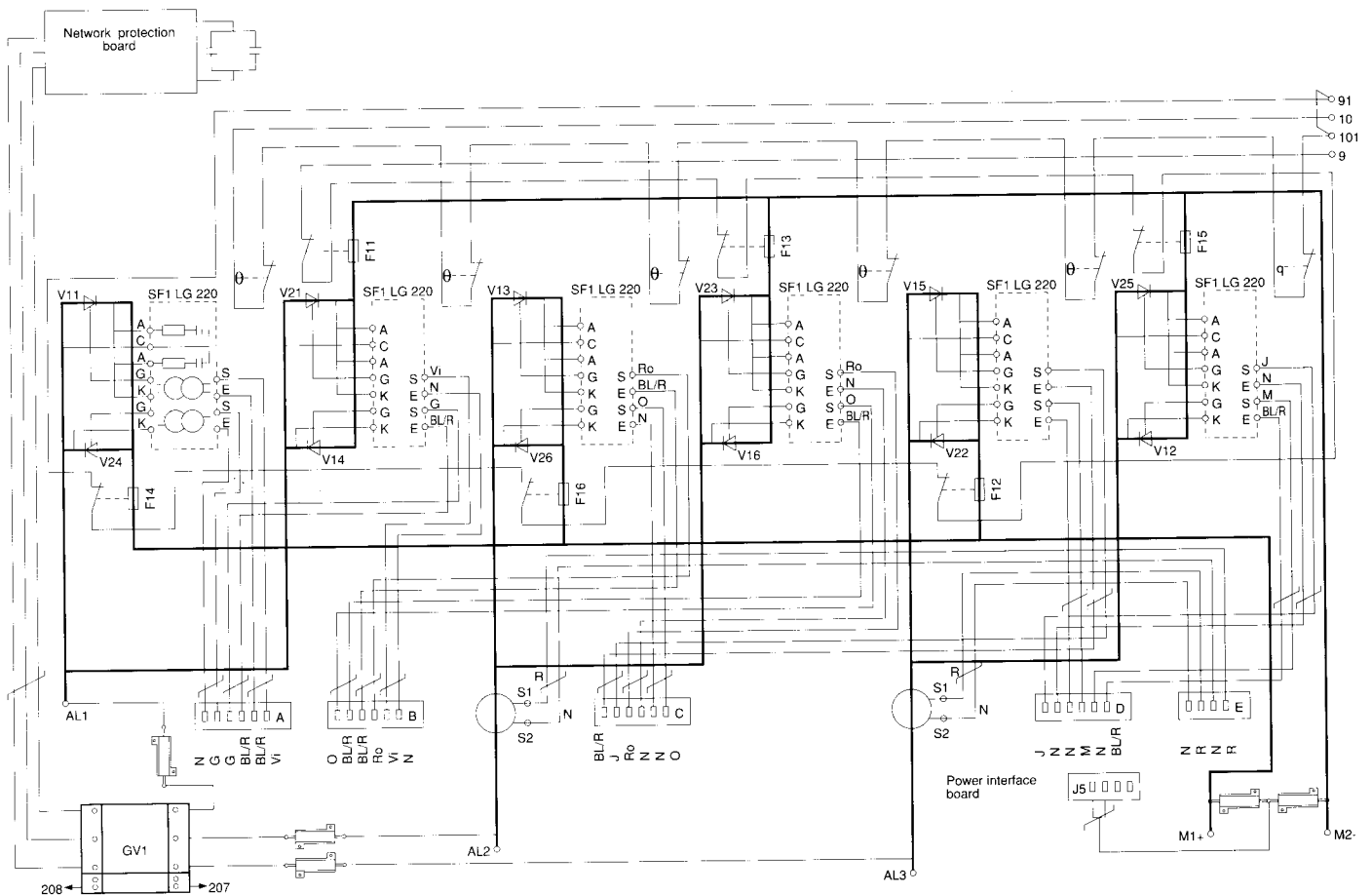

Installation of RECTIVAR 4

Component layout RECTIVAR RTV-641

Power bridge 3000A

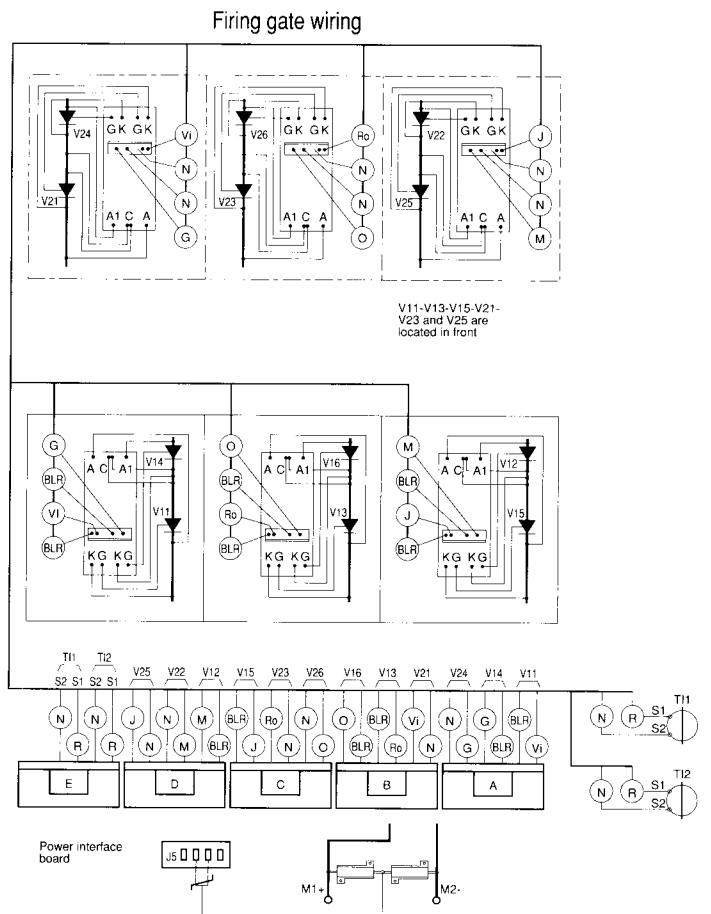
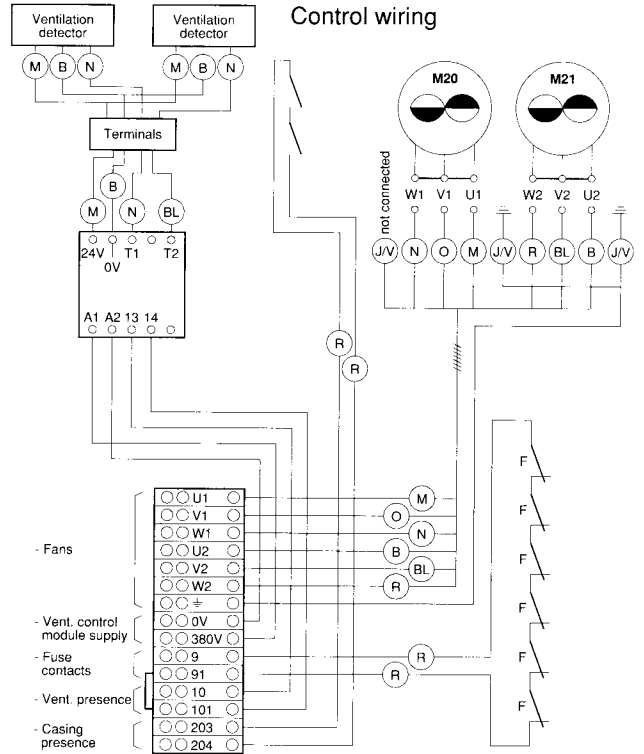
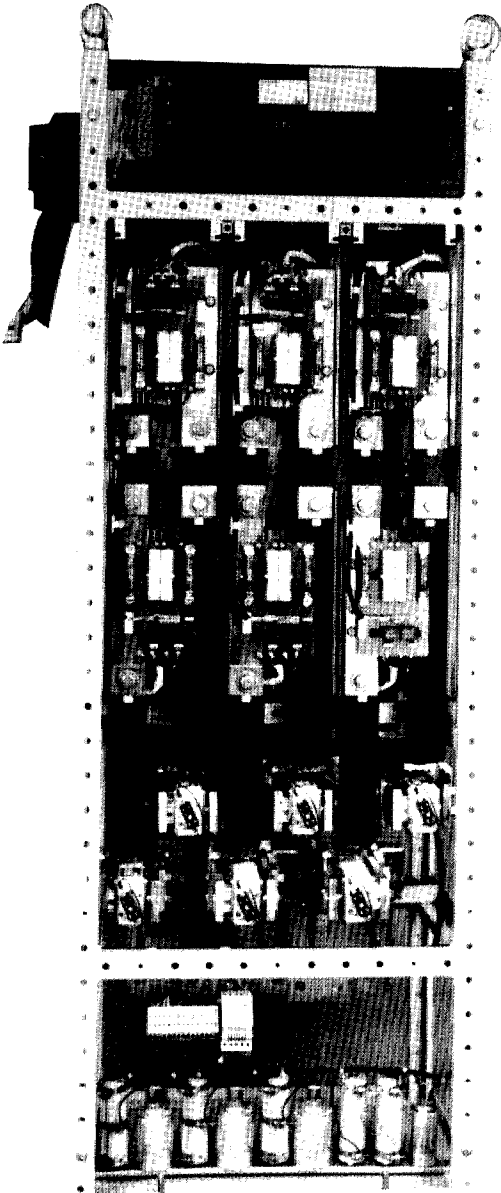

Installation of **RECTIVAR 4**

Component layout

Power interface
board 16A
VX5-RLD101

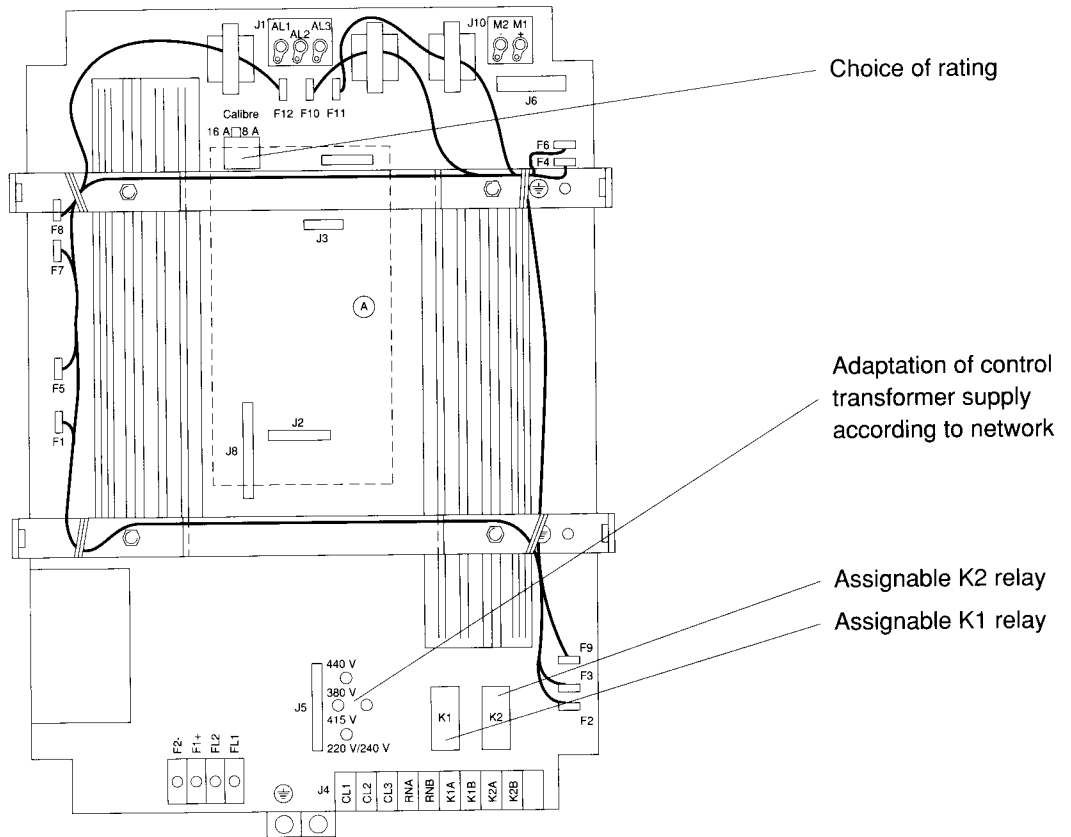

- J1: 50/60Hz three-phase network supply
- J2: control board connections
- J3: control board connections
- J4: external connections
- J5: control transformer connections
- J8: galvanic insulation board connections
- J10: motor armature connections
- A: galvanic insulation board (optional)

Installation of RECTIVAR 4

Component layout

Power interface board 32 to 650A
VX5-RZD109

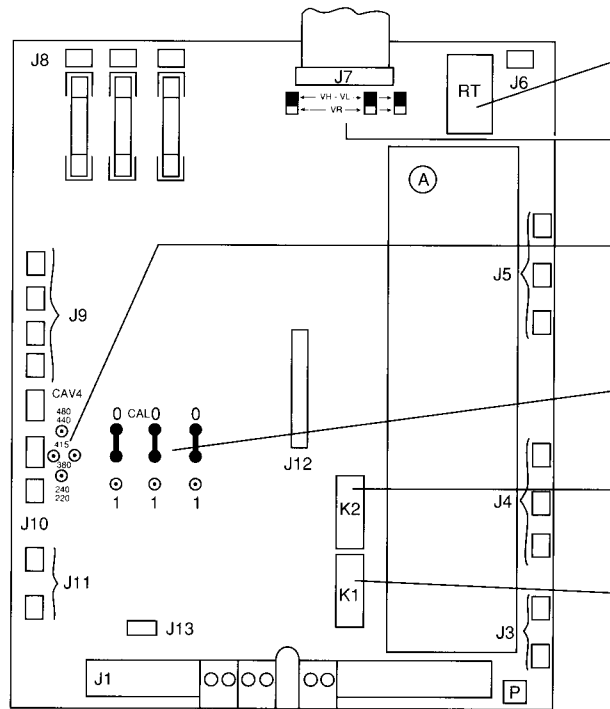

Current reading adaptation according to rating
Current module page 68

Choice of product type
Set to VL for RTV-641 or VH for RTV-541

Adaptation of control transformer supply according to network

Dissociates control supply from power supply in position 1

Relay K2 is operated when speed controller is beyond limitation or speed = 0 or brake control

Relay K1 is operated when speed controller is validated

For the 220/240V network on ratings C18 and C27, add a strap to J11 (see pages 28-29 and 32-33)

- J3 : thermocontact
- J4-J5 : output to thyristor cathode/gate
- J6 : current transformer reading connections
- J8 : power voltage take off
- J9 : RC connection to thyristor terminals
- J10 : supply and output to control transformer
- J11 : fan supply
- J12 : speed feedback - Adaptation galvanic insulation board
- A : firing gate board (only for RTV-641)

Firing gate board
VX2-DB303L
for RTV-641

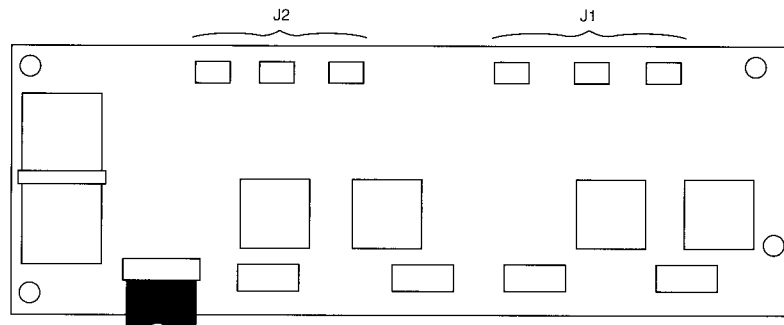

- J1 : output to thyristor gate/cathode: V22, V24 and V26
- J2 : output to thyristor gate/cathode: V21, V23 and V25

Installation of RECTIVAR 4

Component layout

Power interface board
800 to 3000A
VX5-RZD202

Field current feedback adaptation link

Control transformer supply adaptation according to network

Customization connector to be fitted before initial setting up

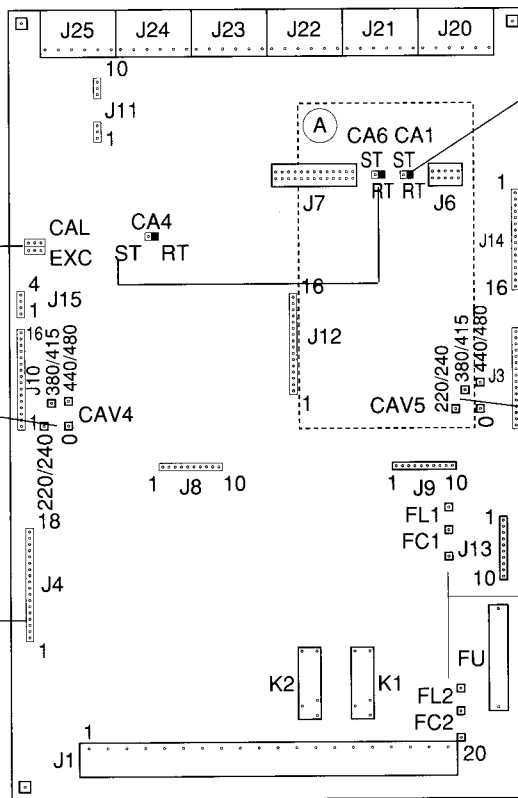

Choice of product type
Set to RT (RTV-541or RTV-641)

Control transformer supply adaptation for field according to network

Dissociates control supply and field supply

A : galvanic insulation board

J3 : supply and output to field control transformer

J5 : field current transformer reading connections

J8, J9 : field control board connections

J10 : supply and output to control transformer

J11, J12 : speed feedback and galvanic insulation board adaptation

J13 : field power voltage recovery

J14 : output to field thyristors gate/cathode

J20 to J23 : outputs to power bridge impulse transformers

J24 : power bridge current transformer reading connections

J25 : armature voltage reading connection

Customization connector J4

RTV-54 1

RTV-64 1

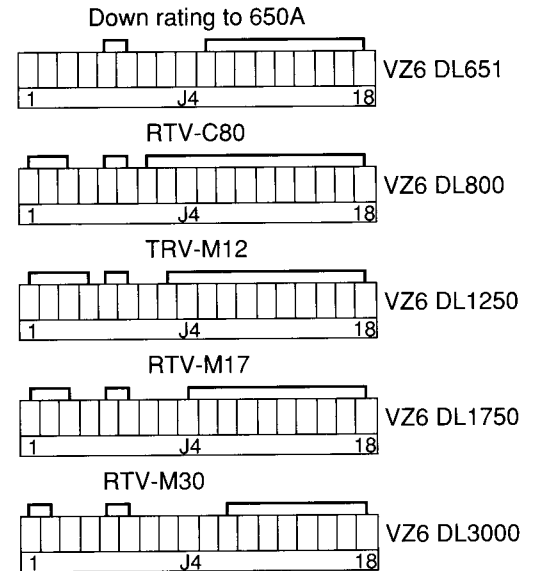
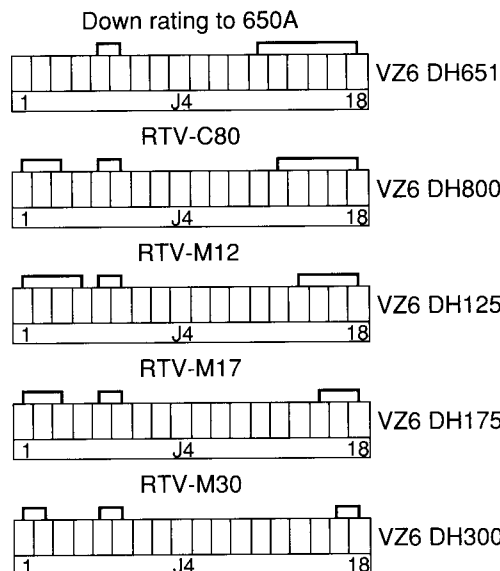

Installation of RECTIVAR 4

Component layout

Controlled field
board 800 to 3000A
VX4-RZD104

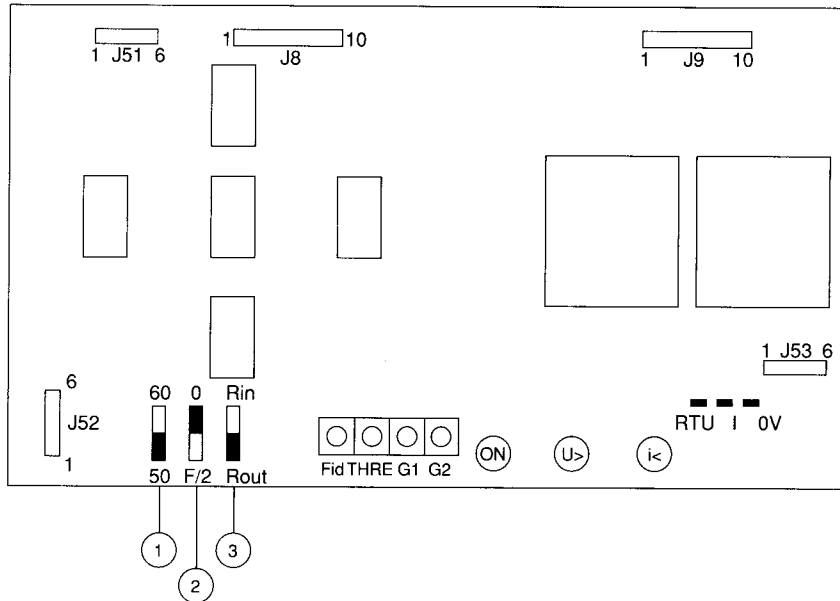

Light-emitting diodes:

ON : field supply on
U > : armature overvoltage
I < : field supply fault

Links:

- ① Network frequency selection.
- ② Normal operating (position 0) or at reduced flux (position 1), internal reference.
- ③ Set to R. OUT for field current reference from adjustment board.

Potentiometers:

Fid: adjustment of field current (only for independent controlled field),
THRE: adjustment of armature voltage threshold for field weakening function,
G1 and G2: adjustment of voltage loop gain (for field weakening only).

Installation of RECTIVAR 4

Component layout

Control board
VX4-RZD303

Selector switch CM1 for choosing the product type. Set as shown below.

RTV-541

RTV-641

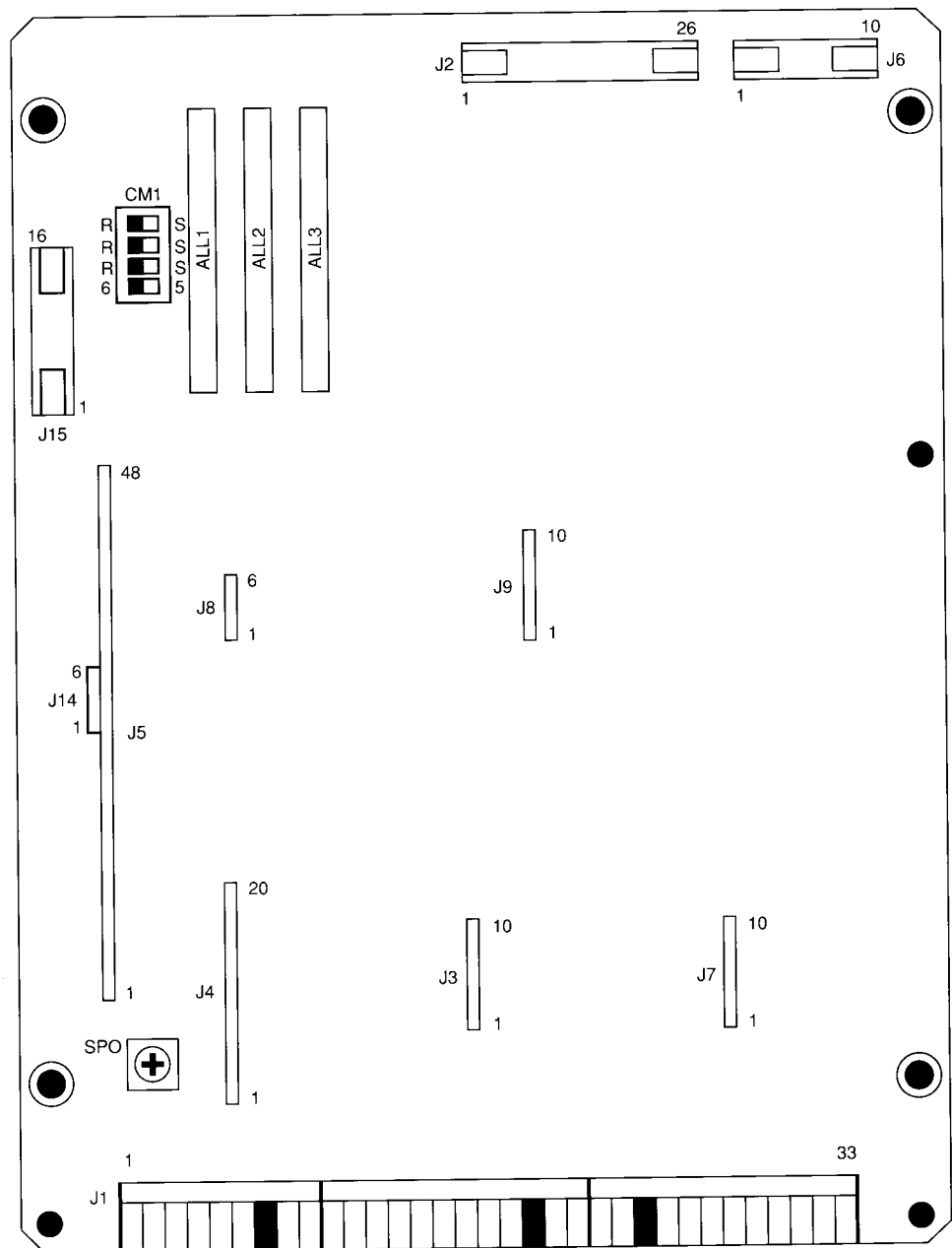
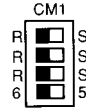
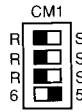

SPO: adjustment of the amplifier offset (factory preset).

Installation of RECTIVAR 4

Component layout

Adjustment board VW2-RZD303

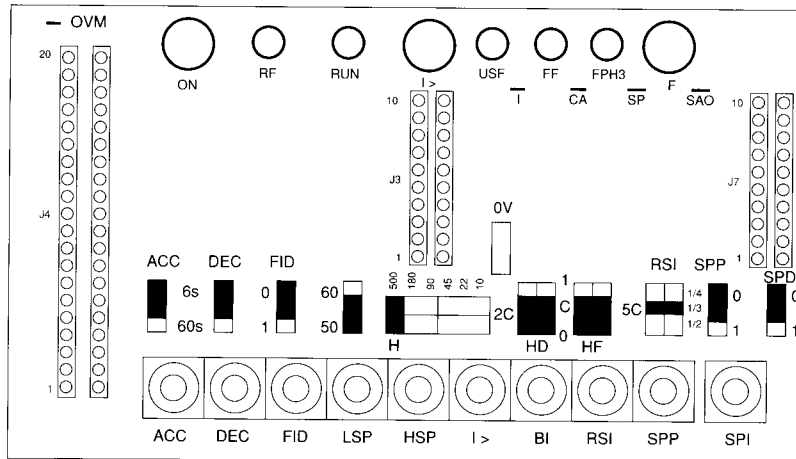

■ Initial position of links

• Links

- 0V : interchangeability link (install only for RTV-54 or 64 when the board is used as a spare part and not new RTV-541/641)
- ACC : acceleration time adjustment range
- DEC : deceleration time adjustment range
- FID : cancellation of "field current presence" function (position 0)
- 50/60: selection of network frequency (50 or 60Hz)
- H : selection according to voltage feedback level
- HD : speed feedback derivative (selection of time constant) (page 57)
- HF : filter on speed or voltage feedback (selection of cut off frequency) (page 57)
- RSI : current loop adaptation (page 57)
- SPP : speed loop static gain adjustment range
- SPD : speed loop derivative action

• Potentiometers

- ACC : acceleration time adjustment
- DEC : deceleration time adjustment
- FID : adjustment of "field current presence" comparator threshold (active if link FID on 1)
- LSP : low speed adjustment (page 64)
- HSP : high speed adjustment (page 63)
- I > : limitation current value adjustment (page 62)
- BI : braking current adjustment (page 63)
- RSI : current loop response time adjustment
- SPP : speed loop proportional gain adjustment
- SPI : speed loop integral gain adjustment

Note : after testing in factory, the potentiometers RSI, SPP and SPI are preset to 1/3 of the travel. FID and BI are turned fully clockwise, and ACC, DEC, LSP, HSP and I > turned fully anticlockwise.

• Test points

- 0VM : 0V
- I : current signal (+ 5V average for I > adjustment with ECL not activated)
- CA : current loop output (0 + 10V)
- SP : speed or voltage signal (± 8 V for maximum speed set by HSP)
- SAO : speed loop output (± 10 V)

• Light-emitting diodes (see page 57).

Utilisations of RECTIVAR 4

Simplified sequence diagrams
Supply: 380/415V or 440V, 50/60Hz
16 to 72A speed controllers

Recommended circuit diagram

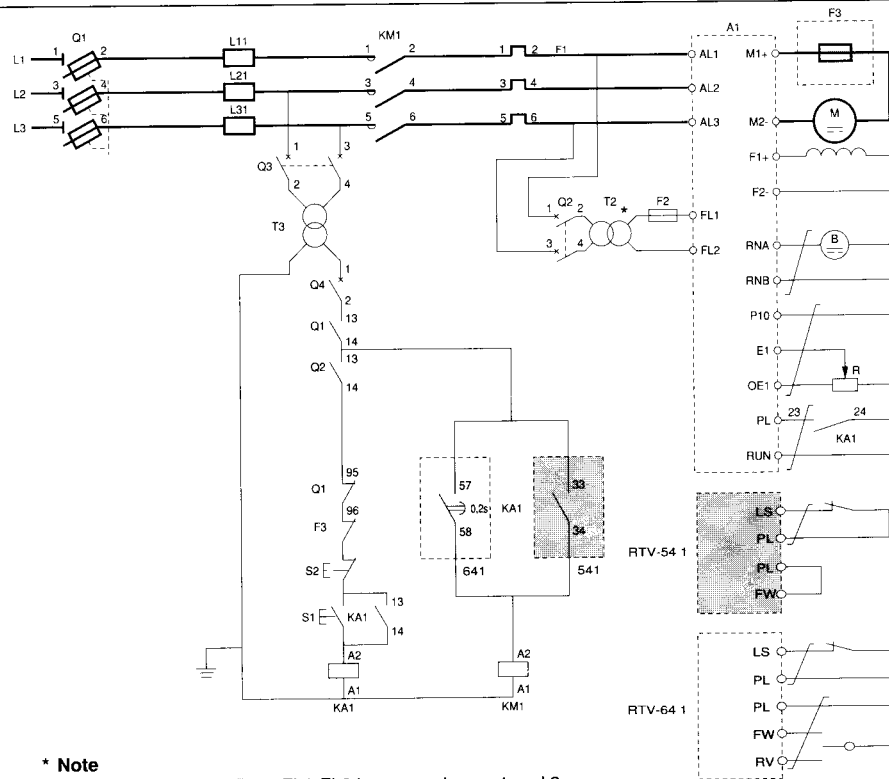

Nomenclature of the required equipment

* Note
Connect transformer T2 or FL1-FL2 between phases 1 and 3,
F2, T2 if necessary, depending upon network and field voltages.

Item	Designation	Reference	Reference	Reference	Reference
Max. power with Td/Tn = 1.2 and armature voltage 440V/400V (541/641)					
M	Motor	4.7kW/4.3kW	10kW/9.1kW	15.5kW/14kW	23kW/21kW
A1	Speed controller	RTV-641D16Q	RTV-541/641D32Q	RTV-541/641D48Q	RTV-541/641D72Q
F1 (4)	Thermal relay	LR1-D...A65	LR1-D...A65	LR1-D...	LR1-D...
F2	Fuse + carrier	Calibrated to field current when cold + DF6-AB10			
F3 (3)	Fuse	DF3-EF04001(2)	DF3-FF05002 (2)	DF3-FF05002(2)	DF3-FF10001(2)
KA1	Control relay	CA2-DN140MA65	CA2-DN140MA65	CA2-DN140MA65	CA2-DN140MA65
	Time delay block (3)	LA3-D20A65	LA3-D20A65	LA3-D20A65	LA3-D20A65
KM1	Line contactor	LC1-D163MA65	LC1-D253MA65	LC1-D403M	LC1-D503M
L11-L21-L31	Line inductances	VZ1-L015 UM17T	VZ1-L030 U800T	VZ1-L040 U600T	VZ1-L070 U350T
Q1 (1)	Isolator	GK1-EV	DK1-FB28	DK1FB28	DK1-GB28
	+ 3 fuses	DF3-EF04001	DF3-FF05002	DF3FF05002	DF3-FF10001
Q2	Circuit breaker	GV1-M...calibrated to twice the primary current of T2 when cold + GV1-A01			
Q3	Circuit breaker	GV1-M04	GV1-M04	GV1-M04	GV1-M04
Q4	Circuit breaker	GB2-CB06	GB2-CB06	GB2-CB06	GB2-CB06
R	Potentiometer	SZ1-RV1202	SZ1-RV1202	SZ1-RV1202	SZ1-RV1202
S1-S2	Control	XB2-M or XB2-B			
T2	Transformer	Network ≥ 440V, secondary 220V, P (VA) = 1.5P field (W) motor hot			
T3	Transformer	Primary: 380V, 415V, 440V or 500V - Secondary: 220V - Power 100VA			

(1) UR fuses incorporated in the isolator.

(2) Fuse to be mounted on carrier (see page 25). In the case of RTV-641D...S products, mount 2 fuses in the armature loop.

(3) For RTV-641 only, not needed with RTV-541.

(4) Thermal relay calibrated according to motor rated current. Rating = 0.82 motor rated current.

Note: if network different from 380/415V or 440V AC, supply the control (CL1/2/3) via a three-phase auto-transformer P ≥ 40VA, sec. 380V 50/60Hz.

Utilisations of RECTIMAR 4

Simplified sequence diagrams
Supply: 380/415V or 440V, 50/60Hz
180 to 650A speed controllers

Recommended circuit diagram

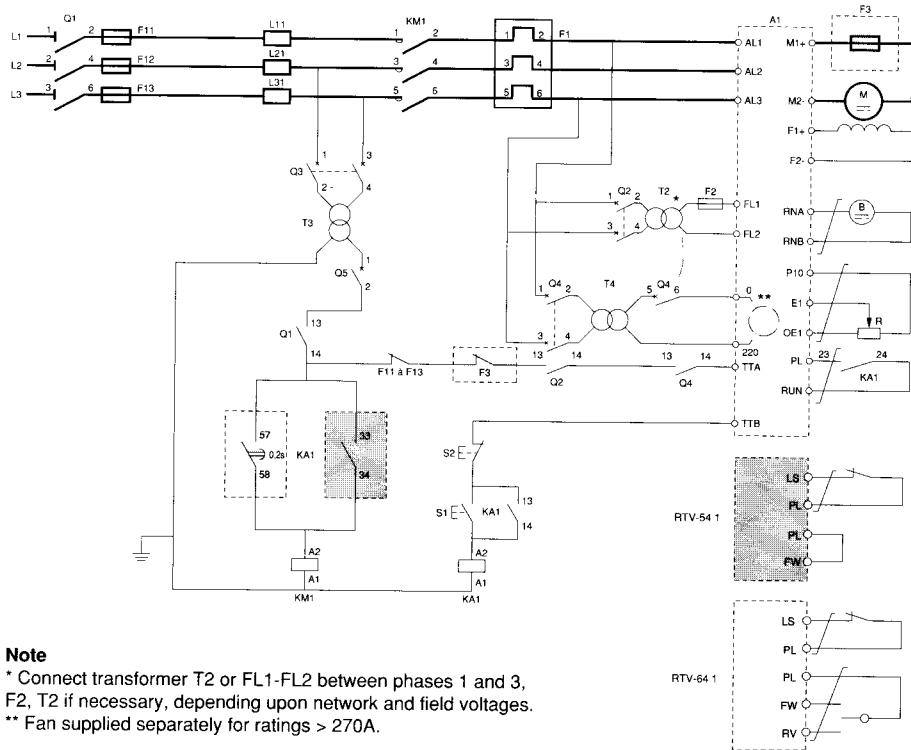

Note

- * Connect transformer T2 or FL1-FL2 between phases 1 and 3, F2, T2 if necessary, depending upon network and field voltages.
- ** Fan supplied separately for ratings > 270A.

Nomenclature of the required equipment

Item	Designation	Reference	Reference	Reference	Reference
Max power with Td/Tn = 1.2 and armature voltage 440V/400V (541/641)					
M	Motor	59.5kW/54kW	89.5kW/81.5kW	132kW/120kW	214kW/195kW
A1	Speed controller	RTV-541/641C18Q	RTV-541/641C27Q	RTV-541/641C40Q	RTV-541/641C65Q
F1 (3)	Thermal relay	LR1-F	LR1-F	LR1-F	LR1-F
F2	Fuse	Calibrated to field current when cold			
	+ support	DF6-AB10	DF6-AB10	DF6-AB10	DF6-AB10
F3 (2)	Fuse (1)	DF3-NF25002	DF3-NF40002	DF3-NF50002	DF3-QF80002
KA1	Control relay	CA2-DN140MA65	CA2-DN140MA65	CA2-DN140MA65	CA2-DN140MA65
	Time delay block (2)	LA3-D20A65	LA3-D20A65	LA3-D20A65	LA3-D20A65
KM1	Line contactor	LC1-FF43	LC1-FG43	LC1-FJ43	LC1-FK43
	+ coil	LX1-FF220	LX1-FG220	LX1-FJ220	LX1-FK220
L11-21-31	Line inductances	VZ1-L150 U170T	VZ1-L250 U100T	VZ1-L325 U075T	VZ1-L530 U045T
F11-12-13	Fuses (1)	DF3-NF25002	DF3-NF40002	DF3-NF50002	DF3-QF80002
Q1	Isolator	DK1-HC2312	DK1-HC2312	DK1-KC2312	DK1-KC2312
Q2	Circuit breaker	GV1-M.. calibrated to twice the primary current of T2 when cold + GV1-A01			
Q3	Circuit breaker	GV1-M06	GV1-M07	GV1-M08	GV1-M08
Q4	Circuit breaker	-	-	GV1-M06 + GV1-A01	GV1-M06 + GV1-A01
Q5	Circuit breaker	GB2-CB06	GB2-CB10	GB2-CB10	GB2-CB10
R	Potentiometer	SZ1-RV1202	SZ1-RV1202	SZ1-RV1202	SZ1-RV1202
S1-S2	Control	XB2-M or XB2-B			
T2	Transformer	Network ≥ 440V, secondary 220V, P (VA) = 1.5P field (W) motor hot			
T3	Transformer	250VA	400VA	630VA	630VA
T4	Transformer	-	-	630VA	630VA
Secondary: 220V-P = 250VA					

(1) UR fuses to be mounted on bus bar or on carriers (see page 25).

(2) For RTV-641 only, not needed with RTV-541.

(3) Thermal relay calibrated according to motor rated current. Rating = 0.82 motor rated current.

Note: if network is different from 380/415V or 440V AC, include a three-phase auto-transformer, secondary 380V 50/60Hz, P ≥ 40VA for ratings 400 and 650A and 250VA for ratings 180 and 270A, in order to supply the control (CL1-CL2-CL3).

** RTV-641C40 and C65: fan supplied separately at 220V single-phase, power 250VA.

Utilisations of RECTIVAR 4

Simplified sequence diagrams
 Supply: 380/415V or 440V, 50/60Hz
 800 to 1750A speed controllers

Recommended circuit diagram

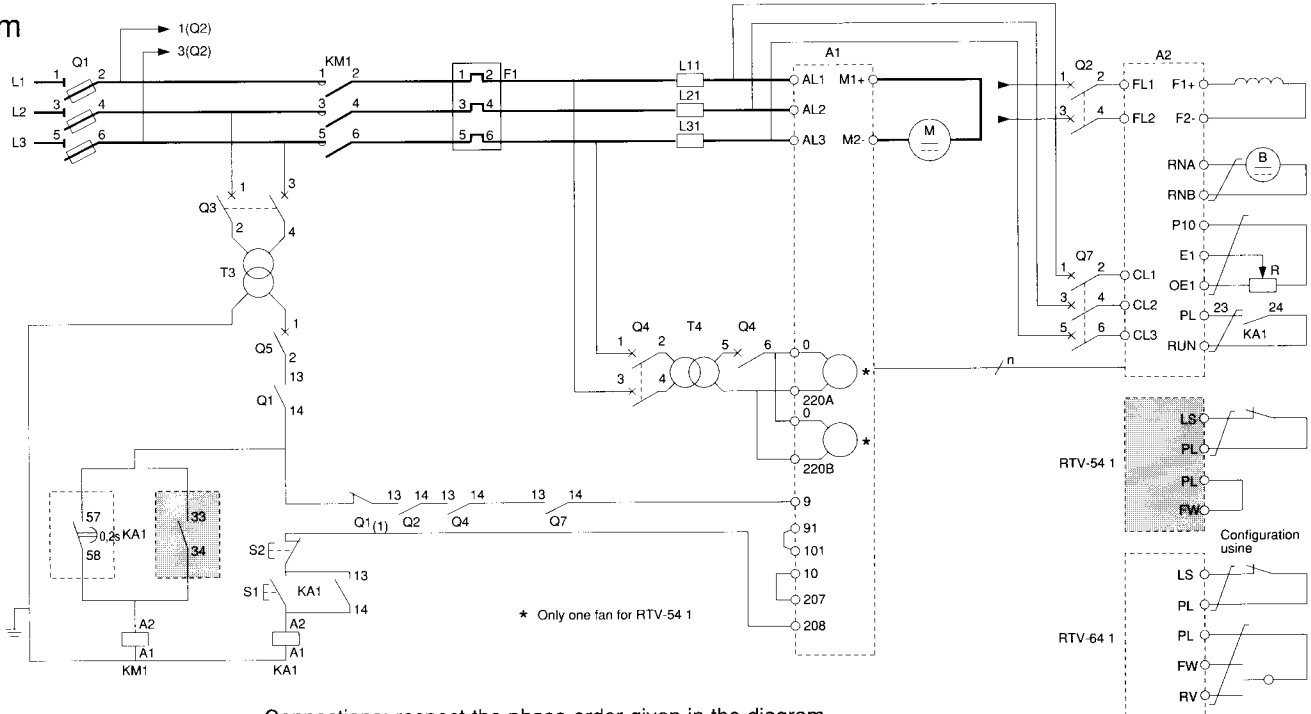

Connections: respect the phase order given in the diagram.
 (1) Circuit breaker contact, if necessary depending on protection type.

Nomenclature of the required equipment

Item	Designation	Reference
F1	Motor protection	thermal dimensioning according to motor power
KA1	Control relay	CA2-DN140MA65
	Time delay block (2)	LA3-D20A65
KM1	Line contactor	to be calibrated according to motor power - See paragraph (1)
L11-L21-L31	Line inductances	VZ1-L650 U038T (RTV..C80*) VZ1-LM10 U024T (RTV..M12*) VZ1-LM14 U016T (RTV..M17*)
Q4	Circuit breaker	GV1-M07 + GV1-A01
Q7	Circuit breaker	GV1-M05 + GV1-A01
S1-S2	Control	XB2-M or XB2-B
T4	Transformer	Secondary: 220V-P = 450VA

The components F1 - Q1 - Q2 - Q3 - Q5 - T3 will be determined according to the operating sequence of the speed controller and the power of the motor associated with them.

Note: in the case of a network different from 220V - 380/415V or 440V AC, provide for:
 - a three-phase auto-transformer $P \geq 40VA$, secondary 380V 50/60Hz to supply the control (CL1 - CL2 - CL3),
 - a single-phase transformer $P (VA) = I \text{ field (motor hot)} \times U \text{ transformer secondary}$, 380V secondary to supply the field (FL1-FL2).

- (1) The line contactor normally operates at zero current and only opens when the machine is switched off. These stipulations usually result in a thermal size. Size the contactor in AC1 operating category according to standard IEC 158-1, for the line rms current, calculated according to the type of continuous or cyclical duty. Take into account the ambient air temperature and the possibility of wiring according to the choice of connections (cables or bars), and the device's connection range.
- (2) For RTV-641 only, not necessary with RTV-541.

Utilisations of RECTIVAR 4

Simplified sequence diagrams
Supply: 380/415V or 440V, 50/60 Hz
3000A speed controller

Recommended circuit diagram

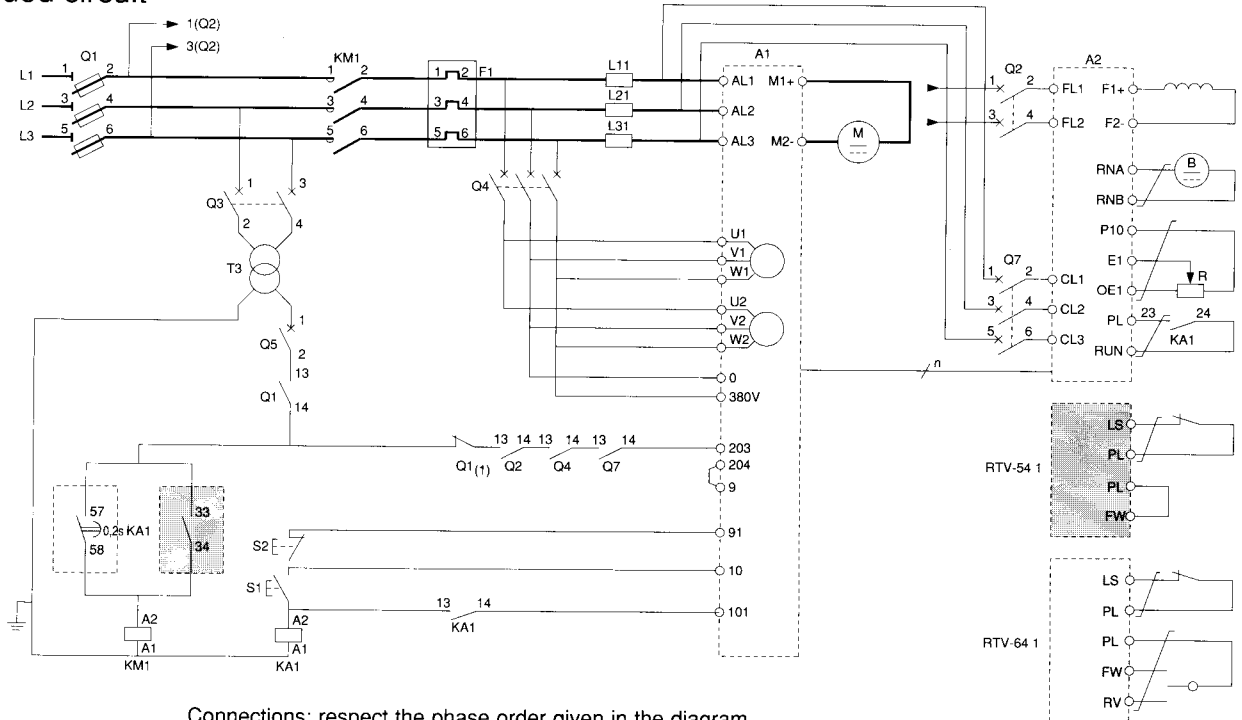

Connections: respect the phase order given in the diagram.
(1) Circuit breaker contact, if necessary depending on protection type.

Nomenclature of the required equipment

Item	Designation	Reference
F1	Motor protection	thermal dimensioning according to motor power
KA1	Control relay	CA2-DN140MA65
	Time delay block (2)	LA3-D20A65
KM1	Line contactor	to be calibrated according to motor power - see paragraph (1)
L11-L21-L31	Line inductances	VZ1-LM24 U010T
Q4	Circuit breaker	GV1-M08 + GV1-A01
Q7	Circuit breaker	GV1-M05 + GV1-A01
S1-S2	Control	XB2-M or XB2-B

The components F1 - Q1 - Q2 - Q3 - Q5 - T3 will be determined according to the operating sequence of the speed controller and the power of the motor associated with them.

Note: in the case of a network different from 220V - 380/415V or 440V AC, provide for:
- a three-phase auto-transformer $P \geq 40VA$, secondary 380V 50/60Hz to supply the control (CL1 - CL2 - CL3),
- a single-phase transformer $P (VA) = I \text{ field (motor hot)} \times U \text{ transformer secondary}$, 380V secondary to supply the field (FL1-FL2).

Fans supply: provide for a three-phase transformer $P \geq 1100VA$ for a network different than 380V.

(1) The line contactor normally operates at zero current and only opens when the machine is switched off. These stipulations usually result in a thermal size. Size the contactor in AC1 operating category according to standard IEC 158-1, for the line rms current, calculated according to the type of continuous or cyclical duty. Take into account the ambient air temperature and the possibility of wiring according to the choice of connections (cables or bars), and the device's connection range.

(2) For RTV-641 only, not necessary with RTV-541.

Connections

Rectivar control board

Use of controls

Control of running direction by FW and RV for RTV-641.



For RTV-541, control by FORWARD-FW is sufficient.

Speed reference input functions

The circuit will take account of the 2 voltage references and/or current references at 0-20mA, 4-20mA.

It is possible to enter the voltage references and current references simultaneously by complying with the conditions given on the next page.

A peak limiting circuit limits the sum of these different references to approximately 10V.

The circuit also ensures the low speed function, a modification of the peak limiting voltage. At the output (SCR), we obtain the algebraic sum of E1, E2 and EC1 up to 10V, or less if the low speed function is active (LS input floating).

Speed reference input use

Control of operating direction by the voltage polarity on E1 or E2 (RTV-641 only). In this case, never use the RV input.

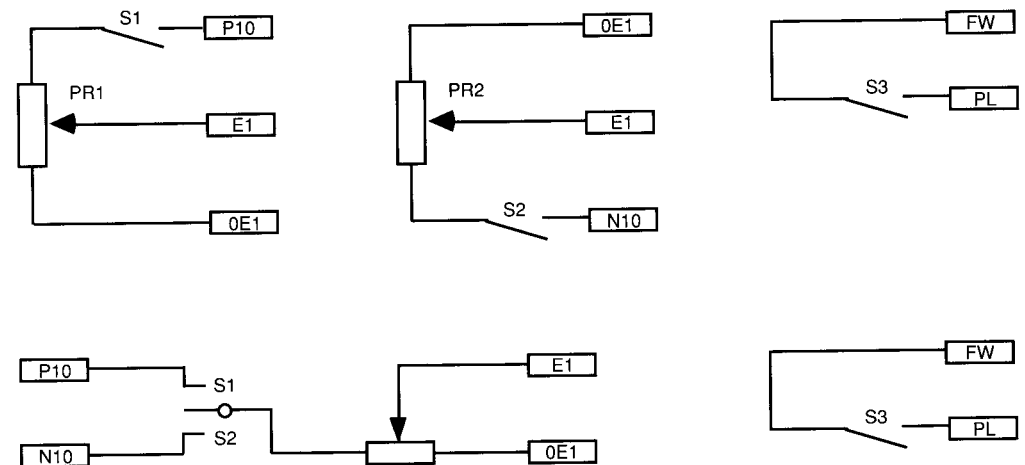

In both cases, the running direction is reversed by S1 and S2 if S3 is closed. For RTV-541, control by terminal P10 is sufficient as above.

Connections

Rectivar control board

• 0-20mA current control

The input impedance is 205Ω. 20mA gives near from 10V (10.2V) at J5.3 (SRC).

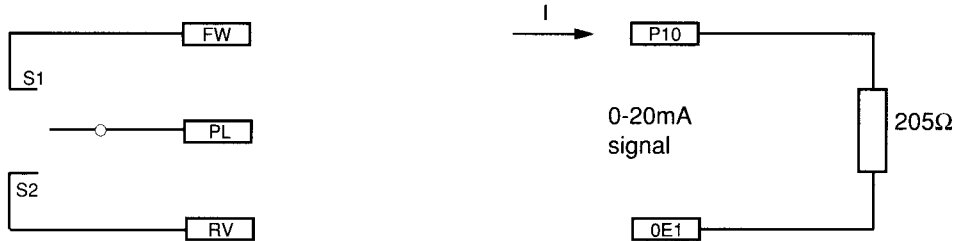

At the same time, a voltage control can be produced on inputs E1 and E2. The running direction is given by action of S1 (or S2 for RTV641).

• 4-20mA current control

In this case, connect the terminals E1, E2 and OE1.

Input impedance: 254Ω. We obtain 10V for 20mA and 0V for 4mA at J5.3 (SRC).

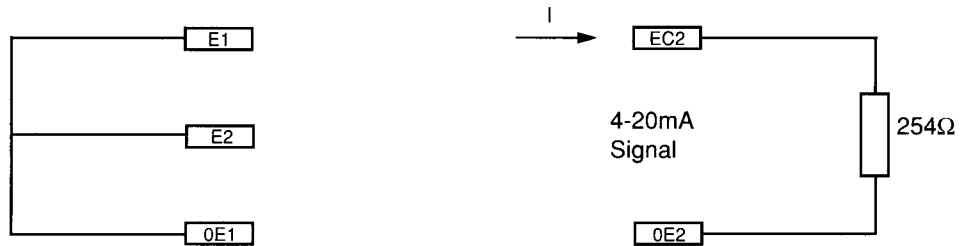

The 4-20mA signal can be used with another type of control if potentiometers from 1 to 5kΩ max., connected between 0V and P10, are used on inputs E1 and E2.

• Reference value peak limiting circuit

When the PL-LS link is removed, the circuit clips the references at the value imposed by the LSP potentiometer so that a low speed can be obtained. By means of this circuit, it will be possible to obtain 2 operating speeds: HSP (high speed) and LSP (low speed). The adjustment limits of the low speed are from 10 % to 100 % of the rated speed.

Adjustment by LSP

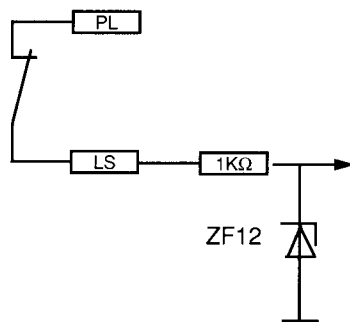

Remote adjustment (LSP at minimum)

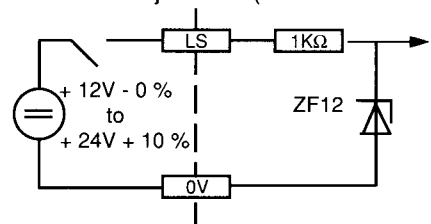

Connections

Rectivar control board

Example of logic input use

If 2 operating speeds are desired (HS - LS), it is possible to use the FW information (or RV information) and LS information, without any external reference potentiometer.

By closing S1 or S2, the running direction can be selected (RTV-641).

The maximum speed is adjusted by the HSP potentiometer.

The low speed, obtained by opening S3, can be adjusted by the LSP potentiometer.

In this way, a handling cycle can be accomplished.

The speed controller is locked when speed zero is reached (speed close to 2 % of N max.).

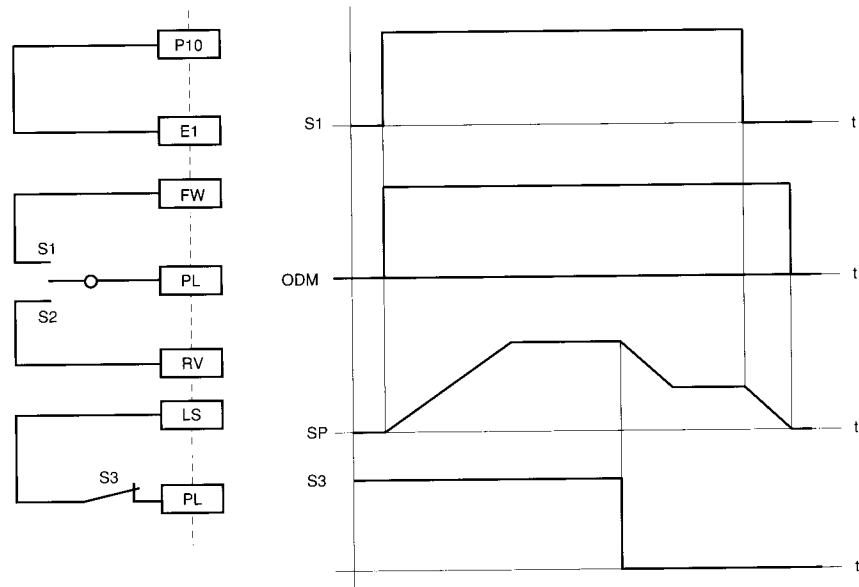

Connections

Rectivar control board

• Ramp

The acceleration (ACC) and deceleration (DEC) times can be adjusted separately. They are adjustable in two ways:

- by a 2-position link which selects 2 ranges: 0.5 to 6s and 6 to 60s,
- by a potentiometer which adjusts the time within each range.

The ramp time can be modified by means of the IRT input (J.124) by wiring a 2.2 kΩ potentiometer as shown in the diagram on the left, or using an analogue output of programmable controller.

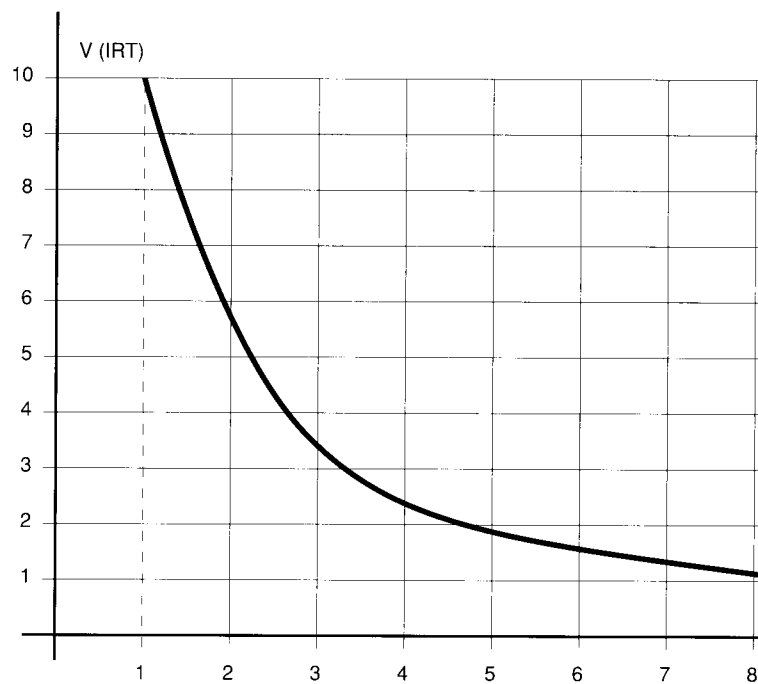
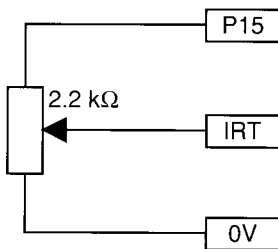

The operating range is from 1 to 10V. Reducing this voltage will increase the overall times adjusted by potentiometers ACC and DEC in a factor varying from 1 to 8.

When the RZR input is not connected, the speed ramp is validated. To reset the ramp to zero, a 0V will have to be set on this input or it must be connected to the 0V terminal of the control board.

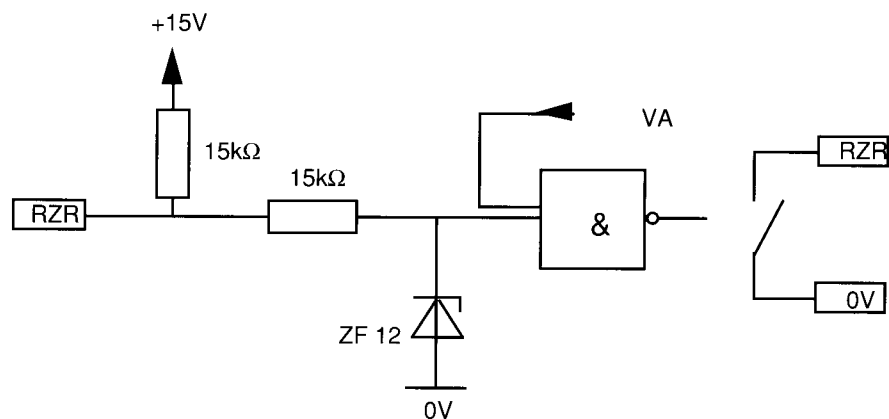

Connections

Rectivar control board

• External current limitation

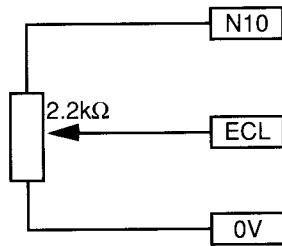

I = approximately 0 with $ECL = -10V$
adjustment 0 to 100 % of the limitation current

• Integration short-circuiting

This input is validated internally by a $15k\Omega$ resistance connected to the +15V. When the ISI terminal is not connected, speed loop integration is validated.

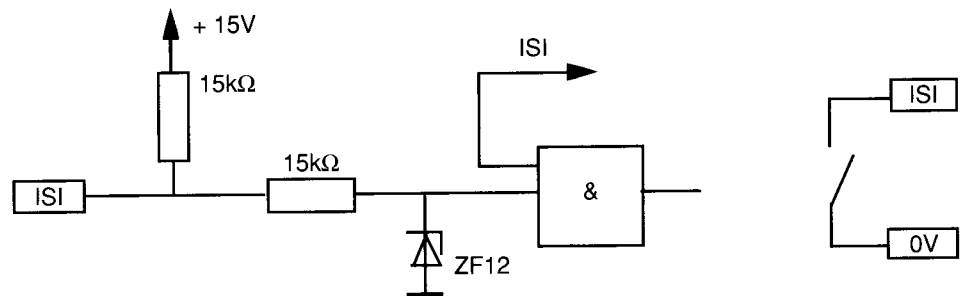

To cancel the integration effect, 0V must be set at the input while an ISI terminal and 0V terminal link is made on the control board.

• Field and network fault outputs

- Field fault (FF)

Open collector transistor output. In the event of a fault, the transistor is turned off and relay K opens.

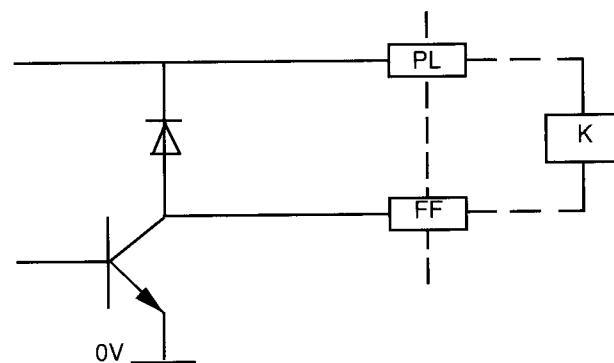

$I_{max} = 20mA$ with 24V voltage.

E.g.: CA2-EN411

- Network fault (SF)

Open collector transistor output. In the event of a fault, relay K opens.

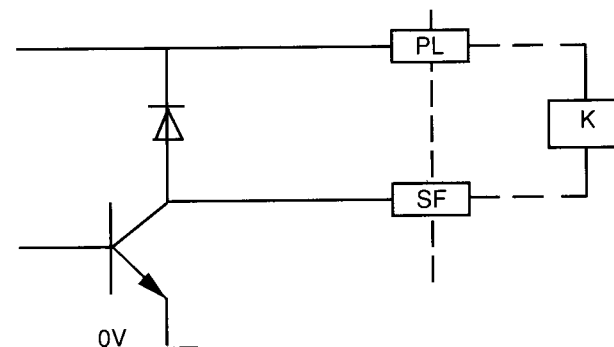

$I_{max} = 20mA$ with 24V voltage.

E.g.: CA2-EN411

Connections

Rectivar control board

Validation logic

The RUN, FW, RV and LS logic inputs are validated by PL or by an external voltage source included between + 12V - 0 % and + 24V + 10 %.

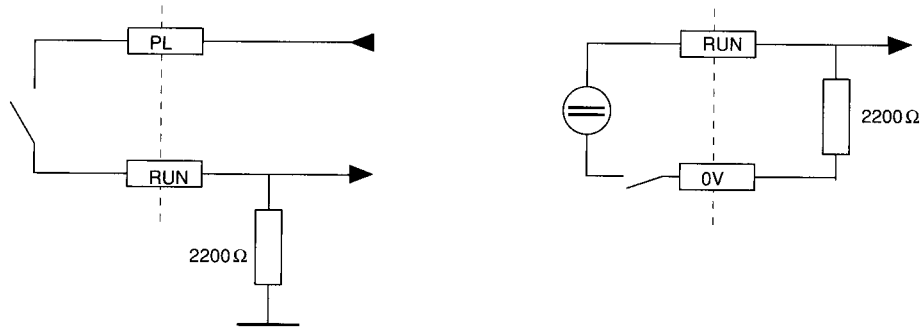

Function of the RUN terminal:

- Validation of the firing gates, ramp, current amplifier and reversing logic for RTV-641.

Precautions to be taken for use of the RUN terminal:

Case 1: common control and power supply - links CAL set of 0.
The RUN order may precede or follow the energizing of the speed controller but must be cut off before its de-energizing (time delay 0.2s).

Case 2: separate control and power supply - links CAL set to 1.
Control is energized upstream of the line contactor.

Comply with the following timing diagram.

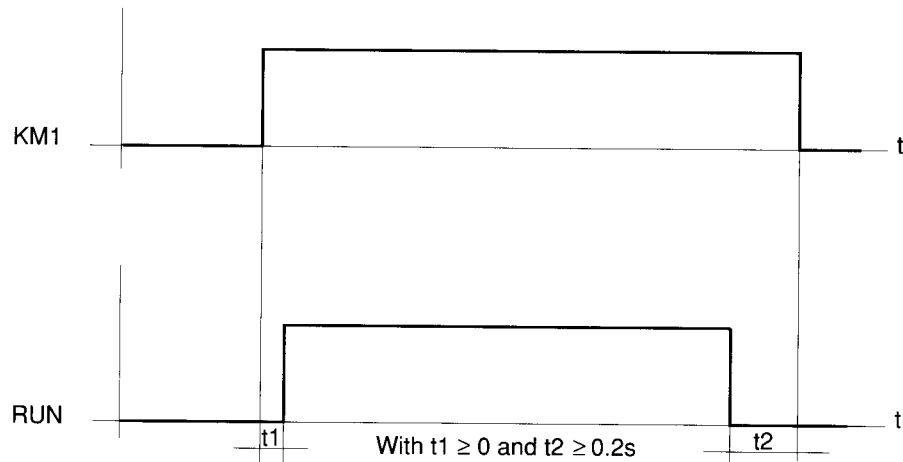

In this case, the RUN order must not precede the energizing of the speed controller and it must be suppressed at least 0.2s before power cut off.

Notes:

1 - The speed controller is validated by simultaneous presence of the RUN and IHL informations. If any of these 2 informations items is set to zero, the speed controller is locked. If a standard sequence is used, the IHL - ODM link will be made in order to control the various validations by means of the control logic.

2 - For RTV-541, time delay t2 can be cancelled: $t2 \geq 0$.

Connections

Rectivar control board

Validation logic

The running order is stored:

- either by the FW-RV information,
- or by the reference detector which, connected to SM (SM-SMA link on terminal block J5, see page 17) applies an operating order through the presence of the speed reference.

The presence of an operating order is indicated by the green LED (RF).

The memory is reset to zero when the 2 following conditions are satisfied:

- no operating order through cancellation of the FW or RV or speed reference detector at 0 information,
- speed zero, i.e. approximately less than 2% of the maximum speed.

The operation of the sequence is illustrated in the figure below.

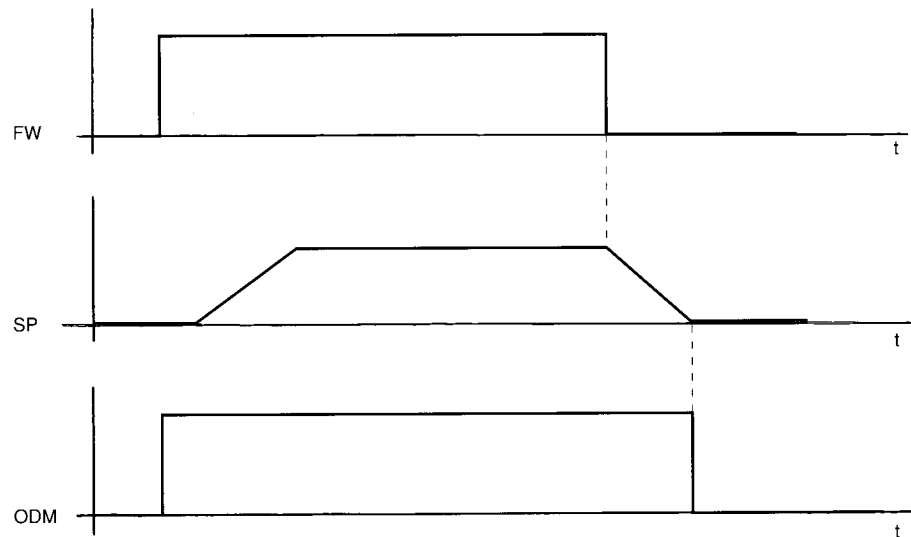

Connections

Controlled field board for ratings \geq C80

This board is fitted on the power interface board. It groups together the following functions:

- field current regulation,
- pulse train firing gate circuit,
- safety on energizing and de-energizing,
- field current presence safety,
- sensor feedback presence safety if the galvanic insulation board is fitted,
- "reduced flux" which cuts down the field current once the running order (FW or RV) has been eliminated and when a speed zero is reached (link F/2 in position 1).
- voltage regulation to maintain the armature voltage constant in the event of field weakening. A safety device checks the stability of the armature voltage.
- to weaken the field, use a galvanic insulation board VW2-RZD207. This board is fitted on the power interface board VX5-RZD202. In this case, the voltage feedback appears on the interface board and a safety function checks that the speed sensor feedback is present.

All this fault informations work on the control board at the "FF" fault level.

The speed sensor feedback presence safety device is available on the power interface board connector.

• Sensor return fault output:

on an open collector transistor, in the event of a fault, the transistor blocks and the relay drops out.

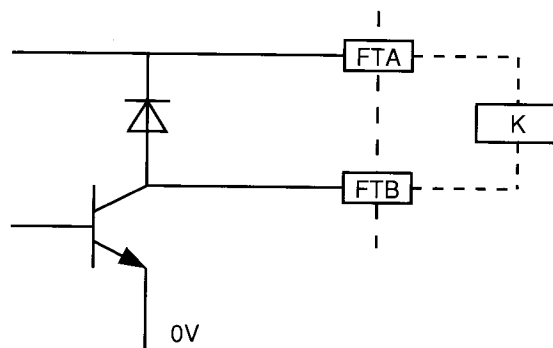

$I_{max} = 20\text{mA}$ at a voltage of 24V.

E.g.: CA2-EN411

CAUTION:

Store the fault in the sequence and provide for a resetting pushbutton

Operation with 1/2 flux standstill

To obtain this mode of operation set the F/2 link of the controlled field board to position 1.

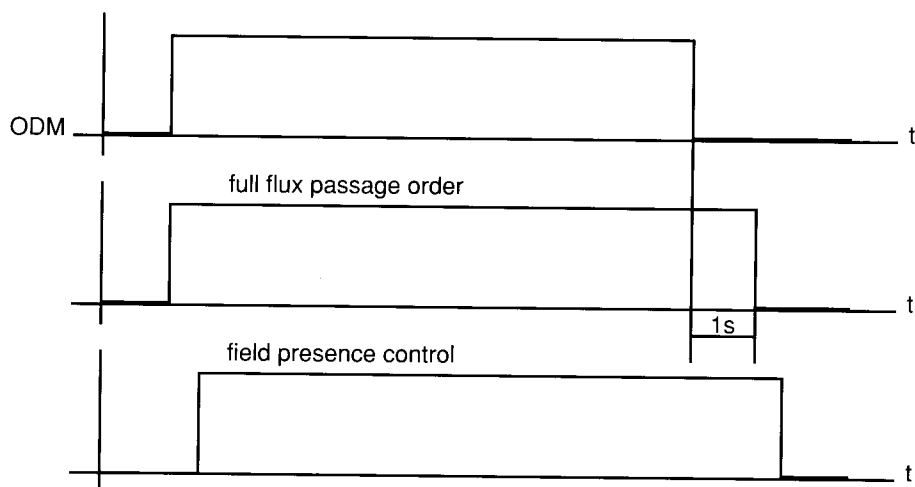

These functions are also found with optional module VW3-RZD1041 for ratings \leq C65.

Operational extension

Use of the galvanic insulation board
ratings \leq C65

Speed servo control
by U feedback without
galvanic insulation
board

For RTV-541 only. This solution is not allowed for RTV-641.

Make the following connections of the power interface board:



Speed servo control
by U feedback with
galvanic insulation
board

Install the galvanic insulation board on the power interface board and connect it with strips 1 and 3 supplied with the board.

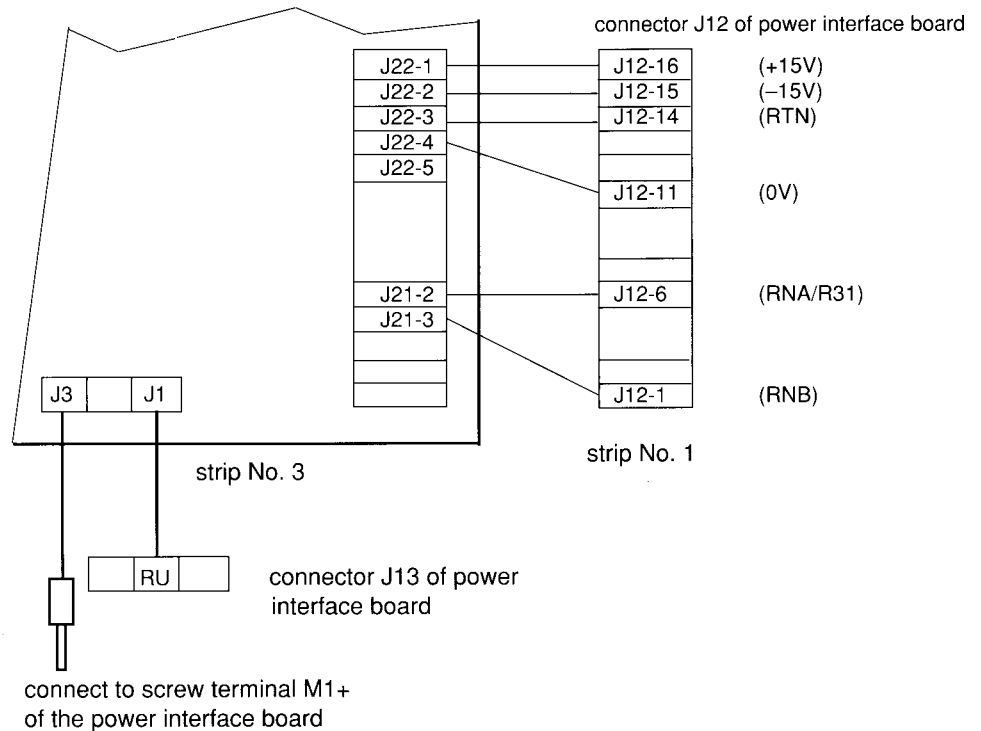

Operational extension

Use of the galvanic insulation board ratings \geq C80

The product is supplied for controlled field operation: using a galvanic insulation board VW2-RZD207 (see specific document), it is possible to obtain the following operating modes.

Speed servo control by U feedback

Set the link H on adjustment board to position 10.
Install the galvanic insulation board on the power interface board and connect it with strips 1 and 4 supplied with the board.

In this case, it will be impossible to operate by field weakening.

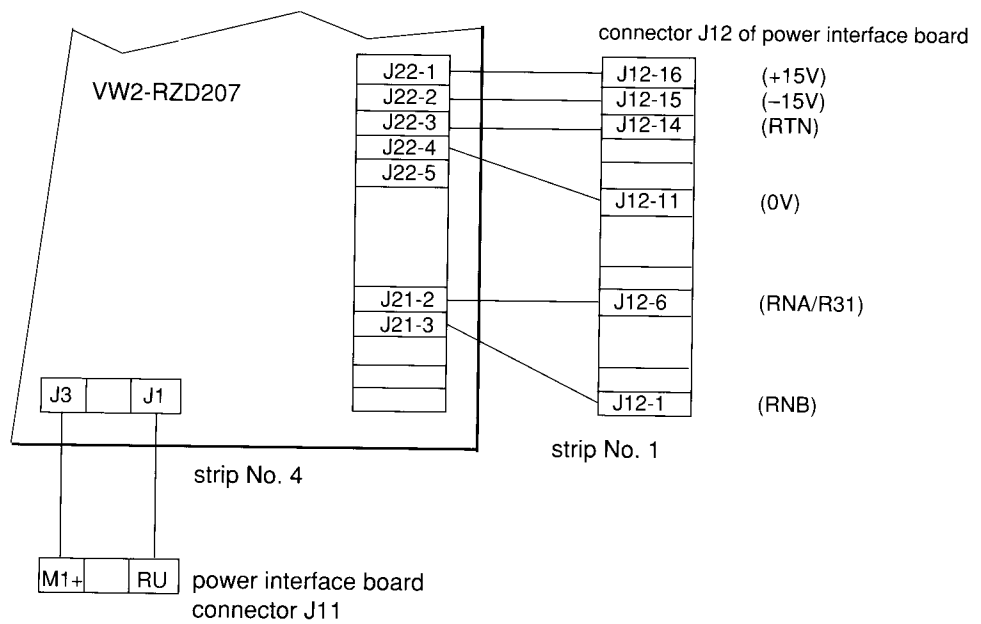

Tachogenerator feedback monitoring

Install the galvanic insulation board on the power interface board and connect it with strips 2 and 4 supplied with the board.

In this case, it is possible to operate by field weakening.

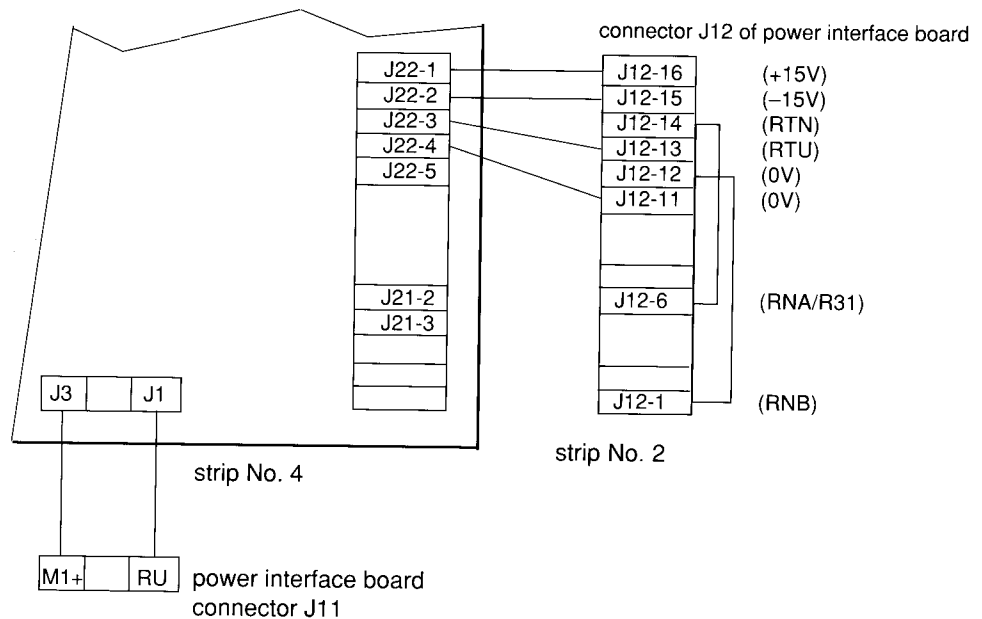

Operational extension

Use of the galvanic insulation board
ratings \geq C80

Field weakening operation

This operating mode is obtained by adding galvanic insulation board and strips 2 and 4. Field weakening is obtained automatically.

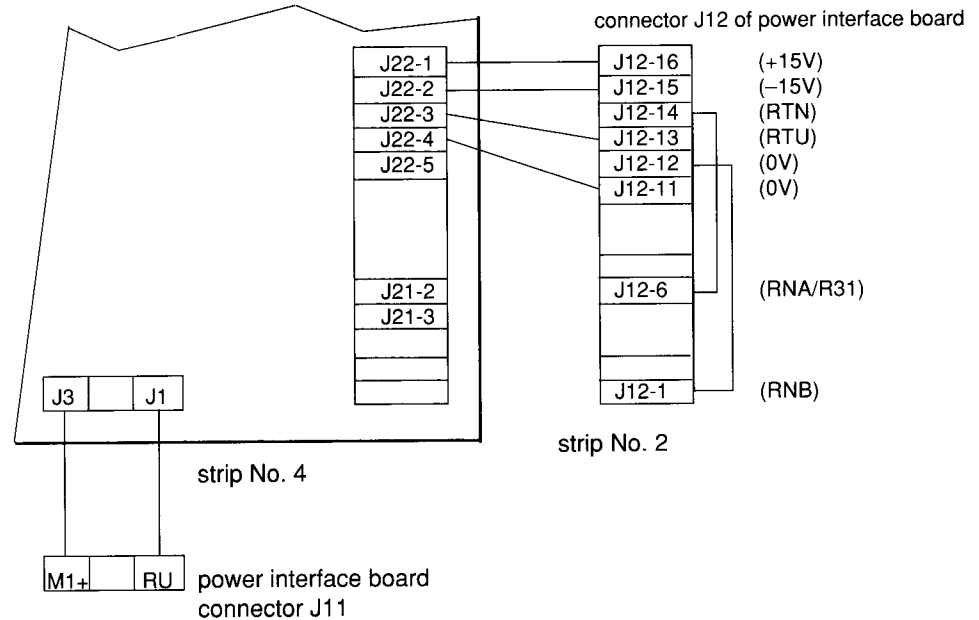

Example: 1500 rpm full flux motor with 60V - 1000rpm tachogenerator.

1st case: no field weakening

Set the link H on adjustment board in position 90.
Adjust HSP on the board to obtain 1500rpm with a 10V speed reference.

2nd case: field weakening up to 3000rpm

Set the link H on adjustment board in position 180.
The speed variation up to 1500rpm is obtained by reducing the field current and regulating the armature voltage (to avoid overvoltages).

High speed adjustment using the HSP potentiometer on the adjustment board.

Note: the various connection strips are supplied with board VW2-RZD207.

Precautions to be taken

Make sure that the machine allows to this type of operation and check compatibility with mechanism to be driven.

E.g.: for hoisting, use a weighing device which will lock the speed reference from a certain load.

In other cases, for switching problems related to the characteristics of the machine, it is better to reduce the current limitation according to the speed by adding the "current reduction" option board VW2-DF308L.

Install a speed controller overspeed detection device to ensure the safety of the installation.

Commissioning

Preliminary checks

Links on the adjustment board

- HD links: speed feedback derivative (see page 41)



0



C



2C



3C

- HF links: speed feedback filter (to be used when the feedback return is perturbed)



0



C



5C



6C

- RSI links: current loop adaptation



Low inductance motor



Standard motor



High inductance motor

Light-emitting diodes

Adjustment board

- 4 red LEDs

- USF : network energized
- FF : field fault
- FPH3 : phase 3 fault (no phase)
- F : denotes that one of the 3 above faults is present

- 3 green LEDs

- RUN : lit when terminal is activated
- RF : lit when running direction has been selected
- ON : lit when speed controller has received the RUN and RF signal

- 1 yellow LED

- IA > : lit when the speed controller is in current limitation

Note: the light-emitting diodes F, ON and I > are visible with the speed controller cover fitted.

Controlled field board: ratings \geq C 80

- 3 diodes visible on the cover in the bottom part

- ON : lit when field is correct
- U > : lit if overvoltage on armature
- IF < : lit in the event of field fault

Commissioning

Preliminary checks

Switched off

The speed controller is factory preset for the most general utilisation conditions, and terminal block J5 is wired according to configuration 1 (see page 19). Check that the settings are compatible with the utilisation.

By examining the name plates and labels on the installed equipment, check the compatibility between the network, the speed controller and the motor. Check the conformity of the wiring according to the sequence diagram.

Check the tightness of the connections on the terminals and the insertion and locking of the connectors on the speed controller.

Check the position of the links. Make sure they are positioned as shown on pages 36 to 41. The checking of the links on the power interface board requires the opening of the control rack (and disassembly of the controlled field board for ratings \geq C80).

- Power interface board

- *Controlled field power supply (ratings \geq C80):*

Remove the controlled field board.

Install connector J4 supplied with the power bridge (see page 38).

If the network is different from 220/240V, 380/415V or 440V, position the two CAL links at FC1 and FC2 and insert an auto-transformer between the network and terminals FC1 and FC2 in order to supply the control at 380V. Set the link CAV5 in the 380/415V position (page 38). Set the field current caliber link (CAL10 - 20 - 30) according to the motor.

If there is no galvanic insulation board, check that connector J12 is present on the power interface board.

Install the controlled field board and connectors J51 and J9.

- *RECTIVAR control supply (ratings \geq C80 and rating D16):*

Supply power to CL1-CL2-CL3, making attention to the synchronisation of phases (page 60) and set the link CAV4 according to the supply voltage.

If the power interface board is replaced, install connector J4 or the RT module adapted to each rating (pages 36, 38 and 68).

- Power interface board ratings D32 to C65

If the network is different than 220/240V, 380/415V or 440V, set the 3 CAL links to 1 and insert an auto-transformer between the network and terminals CL1, CL2, CL3 in order to supply the control at 380V. Set the CAV4 link in position 380/415V (page 37).

On ratings C18 and C27, in the event of a 220/240V power supply, install a shunt (supplied with the product) on pins 5 and 10 of connector J11 of the power interface board (see pages 32, 33 and 37).

If there is no galvanic insulation board, check that connector J12 is present on the power interface board. If the power interface board is replaced, install the RT unit adapted to each rating (pages 37 and 68).

- Adjustment and field board potentiometers: preadjustments to be made as indicated on pages 41 and 63.

Caution: for adjustments, make sure that the LSP potentiometer is inactive. To do this, shunt terminals PL and LS on the terminal block of the control board.

Commissioning

Preliminary checks
Static adjustments

Option assembly

- Consult the specific documents.
- *Galvanic insulation board: reference VW2-RZD207*
The product is supplied without this board. If required, mount the board on the power interface board taking care to remove connector J12 (board supplied in kit form). Make sure that the strip choice suits the use to which the system is to be put (pages 54 to 56).
- *Current reduction board: reference VW2-DF308L*
The product is supplied without this board. Mount it on connectors J8 and J9 of the control board without any other wiring.
- *Variable gain board: reference VW2-RZD309*
This board includes the current reduction function.
The product is supplied without the board. Mount it on connectors J8 and J9 of the control board without any other wiring.
- *Vertical movement board: reference VW2-RDL310 (RTV-641 only)*
This board includes the current reduction function.
The product is supplied without the board. Mount it on connectors J8, J9 and J5 of the control board (board supplied in kit form including connectors and board).
- *Field regulator: reference VW3-RZD1041.* The product is supplied without the option. Mount it on the left of the speed controller and connect it.

Static adjustments

Required equipment

- Two multimeters, preferably 20.000 Ω /V.
- If necessary, a two channel oscilloscope.
Exclusively use equipment isolated from the network. Do not connect the oscilloscope earth to another installation earth.
- If necessary, a moving scale ammeter with a shunt in case of need.

Cautions

Check that the LS link (C J1.30)-PL (C J1.28) is set up.
Do not request any direction of movement (RV or FW).
If the current reduction function is used, be sure to first commission and adjust on (see the manual of the option board).
If the field regulator VW3-RZD1041 is used, carry out its prior commissioning with its manual.

Commissioning

Static adjustments

Synchronization checking

- Switch on the equipment.
- The red LEDs FF and F should light up, as well as the ON LED of the controlled field board.
- For a separate power supply of the control (or field), check the phase agreement.

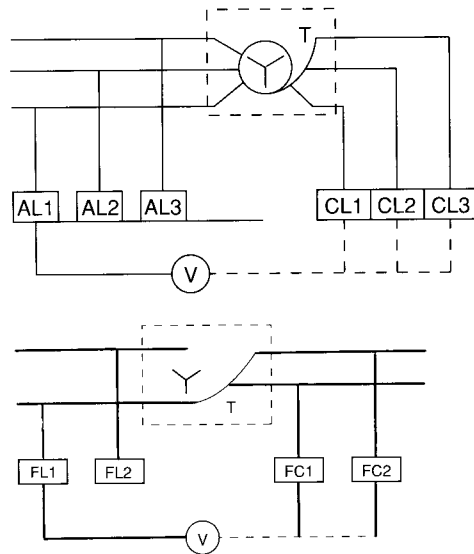

RECTIVAR control

Measure AL1 - CL1, CL2, CL3

For the lowest voltage measured, connect the corresponding wire to CL1.

Measure AL2 - CL2, CL3.

For the lowest voltage measured, connect the corresponding wire to CL2.

Connect the remaining wire to CL3.

Controlled field (ratings \geq C80)

If there is a separate control-power supply:

Measure FL1 - FC1 and FL1 - FC2:

For the lowest voltage measured, connect the corresponding wire to FC1.

Connect the second wire to FC2.

Switch off the equipment.

Reference potentiometer

- Check the value and its connection (check the measure with terminals P10, E1, 0E1 disconnected).
- Recommended value: $2.2\text{k}\Omega$, advisable between $1\text{k}\Omega$ and $10\text{k}\Omega$, power $\geq 3\text{W}$.

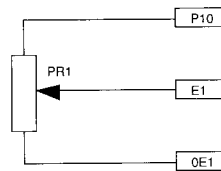

Potentiometer at zero: 0V between 0E1 and E1.

Potentiometer at maximum: $\pm 10\text{V}$ between 0E1 and E1.

Bring the reference potentiometer back to zero.

Adjustment of field current threshold (D16 to C65)

The red LEDs FF and F are always on.
Adjust the field presence safety device using the FID potentiometer on the adjustment board (readjust when the motor is hot).

Check the field supply voltage is correct.

Turn FID anticlockwise until the FF LED goes out. The F LED should also go out (otherwise check the field circuit).

Adjustment limit: 0.5A.

Switch off the equipment.

Adjustment of field current (C80 to M30)

Set the link F/2 on the controlled field board to position 0.

Make sure that the FID link on the adjustment board is in position 1 and that the FID potentiometer is turned fully anticlockwise.

Insert a measurement instrument or a shunt in the field circuit.

Switch on (the ON LED of the controlled field board should light up).

The red LEDs FF and F should light up.

Adjust the current by FID on the adjustment board turning clockwise until the desired value is obtained for the full flux current.

Check that the field supply voltage is correct.

Switch off the equipment.

Operation at reduced flux (ratings \geq C80)

To operate in this mode, set the link F/2 of the controlled field board to position 1, following adjustment of the full flux current.

Commissioning

Static adjustments

Running direction checking

A) Speed servo control by tachogenerator

Set link H on the adjustment board to position 500.

Connect the voltmeter between the RNA and RNB terminals of the power interface board (zero on RNB).

Shunt the integration on the ISI terminal of the control board to 0V.

Caution: the motor may run away if the tachogenerator is reversed or not connected (provide for a sequence stoppage: normal stoppage, emergency stoppage, etc.).

By precaution, the ECL input (C J1.10) can be used to limit the current and to avoid excessive speed (see diagram page 50). For -10V on ECL, the current is limited to a value which is near zero.

Switch on the equipment.

Give the FW movement order. The green LED RF lights up together with the ON LED if a RUN order has been given.

Select a low speed reference (approximately 1/4). The motor begins to rotate.

Check the feedback voltage sign on the voltmeter.

1) If the voltage sign is negative, the motor will not run away.

Check the motor runs in the desired direction for the FW order. If it does not, suppress the FW order and switch off the main power supply of the equipment, and cross the connections of the dynamo to RNA and RNB as well as the field supply on the DC side (F1 and F2).

Remove the FW movement order.

Switch off the equipment.

Position the H link on the adjustment board according to the characteristics of the tachogenerator and the maximum speed of the motor.

2) If the voltage sign is positive, the motor will run away.

Stop the sequence. Remove the FW direction order. Reverse the tachogenerator sign by crossing the connections between RNA and RNB on the power interface board. Resume the running direction checking.

3) If the voltage is zero, stop the sequence and check the continuity of the tachogenerator circuit. Remove the FW direction order and resume the movement test.

Note: the voltage sign of the tachogenerator is valid, within this test, for a given positive reference and for a movement direction FW.

Switch off the equipment. **Eliminate the shunt between 0V and ISI.**

B) Speed servo control by voltage feedback (U)

Set link H to position 10.

Installing the galvanic insulation board VW2-RZD207 and the associated strips insure that the connections are right (see pages 54 to 56).

If the running direction is incorrect, switch off the mains supply and reverse the field connections on the DC side (F1 and F2).

Adjustments: see board manual.

Commissioning

Dynamic adjustments

Standard adjustments

The speed controller is supplied with the response time adjustments given below.

The static gain is defined in terms of adjustment ranges by the SPP link:

- position 0: 4 to 20; position 1: 20 to 100 (link preset in position 0).
- adjustment within each range by potentiometer SPP (preset to 1/3 of its clockwise travel).

Adjustment of the integration constant by potentiometer SPI:

- range adjustable from 20 to 900ms (preset to 1/3 of its clockwise travel).

Potentiometer RSI preset to 1/3 of its clockwise travel.

Limitation current adjustments

Caution

- Do not keep the current limitation on too long because there is a risk of the motor and commutator segments overheating.
- Never exceed the I maximum indicated on the speed controller. For a cyclic speed, see page 11.
- Be sure to derate the speed controller current of 1.2% per °C for ambient temperatures included between 40 and 60°C.

Example:

For an RTV-641C80Q operating at an ambient temperature of 55°C, the derating equals $1.2 \times (55 - 40) = 18\%$, i.e. a derating current of:

$$800 \times \frac{(100 - 18)}{100} = 656\text{A}$$

For a motor used with $T_d/T_n = 1.2$ and efficiency $n = 0.90$, the maximum power available on the motor shaft becomes:

$$\frac{I_{\text{max.}} \times U_{\text{armature}} \times n}{T_d/T_n} = \frac{656 \times 400 \times 0.90}{1.2} = 283\text{kW}$$

Switch off the equipment power supply.

Open the field circuit by disconnecting FL1 and FL2 (or open the sequence fuse).

Cancel the field current presence function: FID link (adjustment board) in position 0.

If possible, lock the motor shaft mechanically. Connect the multimeter between the 0V and DCC terminals of the control board.

Switch on the equipment.

Select the maximum speed (on the reference potentiometer).

Give an FW movement order. The green RF LED should light up as well as the ON LED.

The motor does not run. The I > LED should light up.

Turn I > (adjustment board) clockwise to obtain the desired limitation value while taking T_d/T_n into account. The adjustment limits are $I_p/3$ to I_p .

With the voltmeter connected between 0V and DCC, the indication for the speed controller peak current should be +10V.

E.g.: for RTV-641C80Q, +10V will correspond to 1040A.

- Switch off the equipment.
- Connect terminals FL1 and FL2 again.
- Bring the speed reference potentiometer back to 0.
- Release the motor. Put the FID link into position 1.

- Notes:**
- 1/ For the motors which cannot be set mechanically, the limitation will be "set on the fly" during dynamic adjustments.
 - 2/ For applications requiring faster current loop response times, see pages 65, 66 and 67.

Commissioning

Dynamic adjustments

Braking current

Adjustment by the potentiometer BI on adjustment board. The maximum braking current is equal to the limitation current if BI is turned fully clockwise. It is possible to decrease the setting by bringing BI back anticlockwise to the desired current (BI is a percentage 10 to 100 of the limitation current set by I >).

Adjustment of thermal relay

The thermal relay is dimensioned according to the motor rated current. Rating: 0.82 I_n motor.

Adjustment of maximum speed

a) Without field weakening.

Connect the voltmeter between power terminals M1 and M2 (motor armature voltage).
Turn HSP 4 turns anticlockwise.

Switch on the equipment.

Select RUN, then FW or RV.

Select a reference, the motor should run.

Select the 10V reference.

Adjust the maximum speed of the motor using the HSP potentiometer on the adjustment board and measuring the armature voltage of the machine between M1+ and M2- of the power bridge. Do not exceed the maximum voltage indicated on the name plate. Check that this voltage corresponds to the maximum speed of the machine by measuring the voltage between the RNA and RNB terminals of the power interface board while using a tachometer if the speed control is by voltage feedback.

E.g.: with a tachogenerator

For a motor running at 3000 rpm, 400V armature and a 60V 1000 rpm tachogenerator, check that 180V between RNA and RNB corresponds to approximately 400V between M1+ and M2-.
If this is not the case adjust the field current.

b) Controlled field and galvanic insulation for sensor presence.

In this case, mount the galvanic insulation board. Set the link to the right voltage (see the technical manual of the board).

Make sure that the THRE potentiometer of the controlled field board is turned fully anticlockwise.

c) Field weakening.

In this case, mount the galvanic insulation board VW2-RZD207, and position the link according to the armature voltage (U). See the technical manual of the board.

If necessary, mount the current reduction board VW2-DF308L and start it up using the technical manual.

Connect a voltmeter to the tachymetric voltage and another to the armature voltage.

Turn the HSP potentiometer of the adjustment board to about anticlockwise.

On the controlled field board, turn the potentiometers G1 - G2 fully anticlockwise and the potentiometer THRE fully clockwise.

Switch on the equipment.

Select RUN, then FW or RV.

Select a reference, the motor should run.

Increase the speed until the value corresponds to the full flux nominal speed is reached.

Commissioning

Dynamic adjustments

Example:

For a field weakening speed ratio of 2, the reference will be $10 : 2 = 5V$, motor 1500 rpm, U armature: 400V, tachogenerator 60V/1000 rpm and a possibility of field weaken up to 3000 rpm.

Adjust HSP to obtain 400V armature voltage. Check the speed, if there is a difference, adjust the field current by means of the FID potentiometer of the adjustment board to obtain 400V armature = 1500 rpm.

Adjust THRE to obtain the field weakening threshold by measuring the armature voltage (the threshold corresponding to the beginning of armature voltage decrease).

Check that the armature voltage remains stable while varying the speed reference slightly.

If there is any instability in the armature voltage, adjust the potentiometer G1 on the controlled field board.

Set the speed reference to 10V and check that the safety and mechanical conditions make it possible to field weaken (e.g.: mechanism uncoupled).

Check the speed obtained (e.g.: 180V for 3000 rpm) on the tachogenerator. Otherwise readjust the HSP potentiometer on adjustment board.

If the armature voltage is unstable at high speed, adjust potentiometer G2 on the controlled field board.

Adjustment checking

At zero reference, check that the voltage is around zero between the RNA and RNB terminals of the power interface board.

If this is not the case, adjust the SPO potentiometer on the control board.

If necessary, readjust the maximum speed.

Low speed adjustment

If low speed adjustment is necessary, activate the potentiometer LSP by eliminating the LS and PL link on the terminal block of the control board.

Adjust LSP to obtain the desired value. The adjustment range is 10 to 100 % of the maximum speed.

Ramp times

The ramp times are defined in 2 adjustment ranges. Adjustment is by the ACC and DEC potentiometers on the adjustment board.

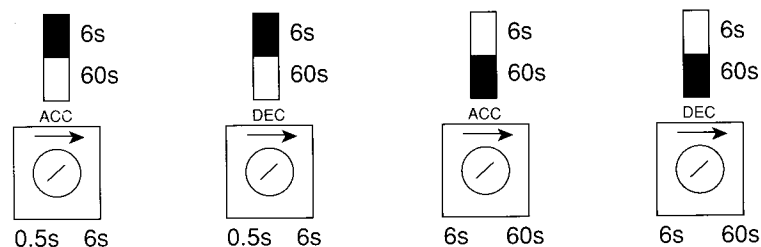

Commissioning

Dynamic adjustments Specific uses

Improved performance

Performance can be improved by means of the potentiometers on the adjustment board:

- RSI : adjustment of the current loop response time (page 66),
 - SPP : speed loop proportional gain adjustment,
 - SPI : integral gain adjustment.
-] see pages 66-67

Set the ramp times to minimum by turning ACC and DEC fully anticlockwise.

The product is supplied adjusted with a current rise time corresponding to applications not requiring high performance.

For applications requiring faster response times, it will be necessary to adjust potentiometer RSI on the adjustment board with the link RSI positioned as per page 57.

Caution: make sure that the di/dt which will be applied can be tolerated by the motor. In general, the di/dt depends on the following parameters:

- maximum motor speed,
- maximum motor current,
- coefficient Ko,

$$\text{giving } \frac{di}{dt} \leq K_o \frac{I_n}{I_{\max.}} \times \frac{N_n}{N_{\max.}}$$

Ko depends on the motor:

- Ko approximately 60 for a solid frame motor,
- Ko approximately 200 for a laminated frame motor.

I_n : rated current
 N_n : nominal speed] manufacturer's catalog indication

$I_{\max.}$: maximum starting or braking current,
 $N_{\max.}$: maximum running speed of the motor,
di/dt : expressed in In/s.

Example:

$I_{\max.} = 1.5 I_n$; $N_{\max.} = N_n$ and laminated frame motor.

$$\frac{di}{dt} = 200 \times \frac{1}{1.5} = 133 I_n / s \text{ giving } 1.5 I_n \rightarrow 11.5 \text{ms}$$

Adjustment: adjustment will be made once the current limitation has been adjusted.

- Connect an oscilloscope, preferably of the memory type, between the 0V and I test points of the adjustment board.
- Open the field circuit on the AC side with FID set to 0.
- Run a test on the stalled motor or test during current limitation at speeding up (in this case, do not disconnect the field).
- Shunt the speed loop integration (terminals ISI and 0V connected together).
- Turn the ACC and DEC potentiometers fully anticlockwise.
- Turn the SPP potentiometer fully clockwise.
- Select the full reference voltage which is equivalent to applying a current reference echelon to the input of the current amplifier.
- Validate the product by FW and RUN.
- Adjust the RSI potentiometer on the adjustment board in order to obtain the fastest possible current rise time without dropping below the calculated value, for instance 12ms, with an acceptable overrun of around 10%.
- **Switch off the equipment.**

AFTER ADJUSTMENT, RETURN THE POTENTIOMETERS AND LINKS TO THEIR INITIAL SETTINGS.

- **Connect the field again.**

Commissioning

Dynamic adjustments
Specific uses

Current rise adjustment • Standard adjustment

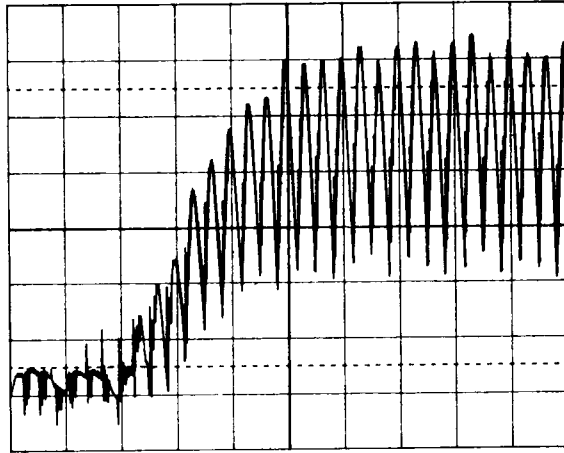

Turn the SPI and SPP potentiometers fully clockwise.
RSI potentiometer set to 1/3 of its clockwise travel.

• Adjustment by means of RSI potentiometer

Adjust the current loop to obtain $1.5I_n$ after 12ms.

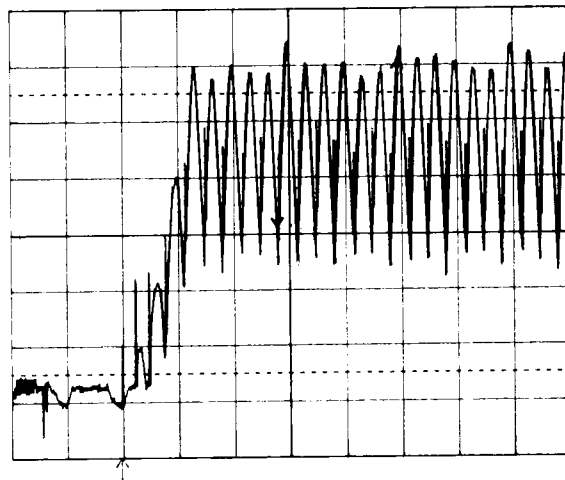

SPI and SPP potentiometers set fully clockwise.

Commissioning

Dynamic adjustments Specific uses

Action on adjustment parameters

- Adjustment of the speed loop:
- select a low speed reference (e.g.: 20 %).
 - validate the product by FW and RUN
 - start by adjusting SPI to the stability limit, see the figure below, then adjust SPP to its stability limit.

Connect an oscilloscope between the 0V and SP test points on the adjustment board. The following curves represent the speed signal as a function of the settings of SPI and SPP.

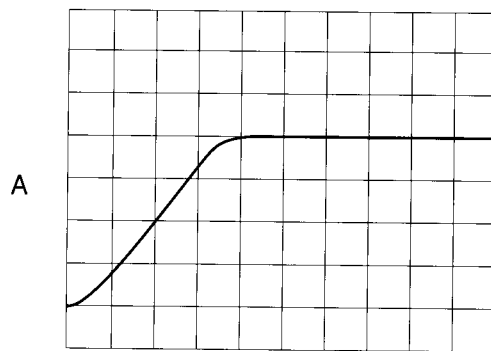

Minimum SPI
Minimum SPP
SPD in position 0

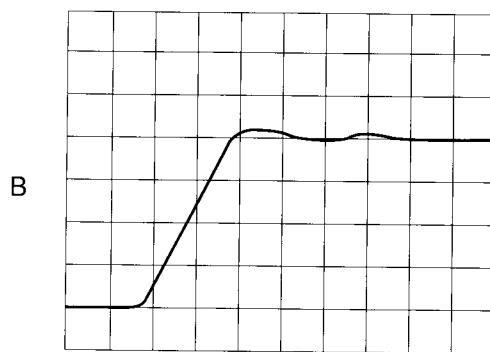

SPI adjusted
Minimum SPP
SPD in position 0

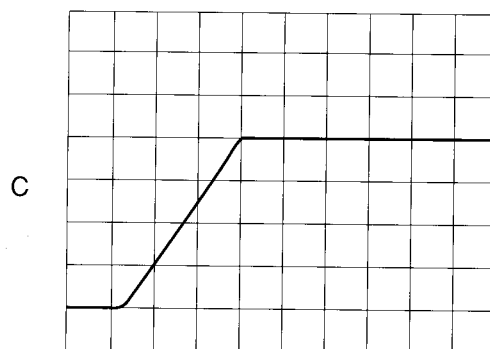

SPI adjusted
SPP adjusted
SPD in position 0

If, after adjusting SPP and SPI, a type B curve is still obtained, put the SPD link in position 1 and move the HD link (page 58) to the point of stability. If necessary, readjust SPI and SPP and the ramp times.

Accessories and spare parts

Boards

Designation	For Rectivar	Characteristics	Unit reference
Control	All ratings		VX4-RZD303
Power interface	D16Q	Current reading adaptation by link 8/16A	VX5-RLD101
	D32 to C65	Without VW2-RHD*** or RLD***	VX5-RZD109
	C80 to M30	Without VZ6-DH*** or VZ6-DL***	VX5-RZD202
Adjustments	All ratings		VW2-RZD303
Firing gates	RTV-641D32 to C65		VX2-DB303L
Galvanic insulation	All ratings	Optional	VW2-RZD207
Vertical movement	RTV-641	Optional	VW2-RLD310
Variable gain	All ratings	Optional	VW2-RZD309
Current reduction	All ratings	Optional	VW2-DF308L
Network protection	C80Q/S to M17Q/S		VX5-RZD108
	C80Y to M17Y		VX5-RZD106
Protection + firing gates	M30Q/S		VX5-RZD101
	M30Y		VX5-RZD103
Protection + firing gates	C80Q/S to M17Q/S		SF1-LG220
	C80Y to M17Y		VX5-RZD107
Controlled field	C80• to M30•		VX4-RZD104
Current module	RTV-541 ≤ C65		VW2-RHD...(1)
	RTV-641 ≤ C65		VW2-RLD...(1)
Customization connector	RTV-541 ≥ C80		VZ6-DH...(1)
	RTV-641 ≥ C80		VZ6-DL...(1)
Starting box	Checks and tests outside external sequence	Connectable and mobile on terminal CJ1	VW3-RZD105
Test box	Analogue signal measurement	Connectable and mobile on connector	SD2-MT21

Adaptations without addition of hardware.

The following functions can be obtained on all rating speed controllers by adaptation to the internal terminal block:

- Assignment of 2 output relays.
- Zero speed integration shunting.

(1) To be mounted on power interface board. Reference to be completed with the rating of speed controller associated for VW2-R.D, and with the max. permanent current for VZ6-D.

E.g.: VW2-RHDD32, VW2-RLDC65, VZ6-DH1750. H signifies 541, L signifies 641.

There are two connectors VZ6-DL651 and VZ6-DH651 adaptable to the VX5-RZD202 to limit to 650A.

There are two connectors VW2-RHDD16 and RLDD16 adaptable to the VX5-RZD109 to limit to 16A.

Fan unit

Fan	C18 and C27		SZ1-XH07
	C40 to M17		VZ3-V001
	M30		SZ1-XH09
Ventilation detector	M30		LH9-ZD001
Detector control module	M30		VW3-RZD101

Field

Rectifier bridge	D16		(2)
	D32 to C27		VZ3-DM4025M1201
	C40 and C65		SZ1-DP170
2-thyristor module	C80 to M30	26A 1200V	VZ3-TM2026M12

Power components

2-thyristor modules or racks		Item Q	Item S	Item Y
For Rectivar	Thyristor current	Thyristor 1200V Unit reference	Thyristor 1600V Unit reference	Thyristor 1800V Unit reference
D16		(2)	-	-
D32 and D48	26A	VZ3-TM2026M12	VZ3-TM2026M16	-
D72	55A	VZ3-TM2055M12	VZ3-TM2055M16	-
C18	90A	VZ3-TM2090M12	VZ3-TM2090M16	-
C27	130A	VZ3-TM2130M12	VZ3-TM2130M16	-
C40	160A	VZ3-TM2160M12	VZ3-TM2160M16	-
C65	250A	VZ3-TM2250M12	VZ3-TM2250M16	-
C80	540A Q/S, 785A Y	VZ3-TP2540M12	VZ3-TP2540M16	VZ3-TP2785M18
M12	900A	VZ3-TP2900M12	VZ3-TP2900M16	VZ3-TP2900M18
M17	1200A	VZ3-TP2M12M12	VZ3-TP2M12M16	VZ3-TP2M12M18
M30	1800A	VZ3-TP2M18M12	VZ3-TP2M18M16	VZ3-TP2M18M18

(2) for the D16 rating, replace the power board VX5-RLD101.

Accessories and spare parts

Fuses

Designation	For Rectivar	Characteristics by unit	Unit reference
Power interface board	All ratings		DF2-DF0040 (1)
Ultra-fast type power fuses	D16Q	6.621CPURGB145140	DF3-EF04001 (1)
	D32Q/S	BUSSMANN 170L2114	DF3-FF05002 (1)
	D48Q/S	BUSSMANN 170L2114	DF3-FF05002 (1)
	D72Q/S	6.621CPURGB2258100	DF3-FF10001 (1)
	C18Q/S	6.6URD31TTF250	DF3-NF25002
	C27Q/S	6.6URD31TTF400	DF3-NF40002
	C40Q/S	6.6URD31TTF500	DF3-NF50002
	C65Q/S	6.6URD33TTF800	DF3-QF80002
	C80Q/S	6.6URD33TTF630	DF3-QF63002
	M12Q/S	6.6URD33TTF900	DF3-QF90002
	M17Q/S	6.6URD33TTF1250	DF3-QFM1202
	M30Q/S	6.6URD2x33TDSF2200	DF3-QQFM2202
	C80Y	12.5BODKC3URE73TTC550	DF3-RF55001
	M12Y	10BODKC4URB73TTC900	DF3-RF90001
	M17Y	10BODKC6URG73TTC1100	DF3-RRFM1101
	M30Y	10BODKC6URK2x73PLA1800M	DF3-RRFM1801
Single pole fuse carriers	D16Q	SI14 + MC1.5	DF5-EA61
	D32• to D72•	SI22 + MC1.5	DF5-FA61
	C18• to C40•		DF5-NZ01 (2)
	C65•		DF5-QZ01 (2)
Fuse contacts	C18 to M30Q/S		VZ1-P001
	C80 to M30Y		VZ1-P002

(1) Sale by individual quantities of 10.

(2) These fuse carriers are not necessary if the fuses can be mounted on connection bars.

Note: the fuse type indicated under "characteristics" is only one of the models which can be delivered under the same reference.

Three-phase line inductances

One per speed controller

Designation	For Rectivar	Characteristics by unit	Unit reference	Weight kg
Inductance	D16Q	15A - 1700 μ H	VZ1-L015 UM17T	2.700
	D32•	30A - 800 μ H	VZ1-L030 U800T	4.700
	D48•	40A - 600 μ H	VZ1-L040 U600T	5.900
	D72•	70A - 350 μ H	VZ1-L070 U350T	10.000
	C18•	150A - 170 μ H	VZ1-L150 U170T	16.000
	C27•	250A - 100 μ H	VZ1-L250 U100T	22.000
	C40•	325A - 75 μ H	VZ1-L325 U075T	32.000
	C65•	530A - 45 μ H	VZ1-L530 U045T	40.000
	C80•	650A - 38 μ H	VZ1-L650 U038T	50.000
	M12•	1025A - 24 μ H	VZ1-LM10 U024T	72.000
	M17•	1435A - 16 μ H	VZ1-LM14 U016T	86.000
	M30•	2460A - 10 μ H	VZ1-LM24 U010T	128.000

If the network power supply is by a specific transformer or auto-transformer, or if the inductance of the three-phase line wiring value is equal to or greater than the indicated value, the line inductance is not necessary.

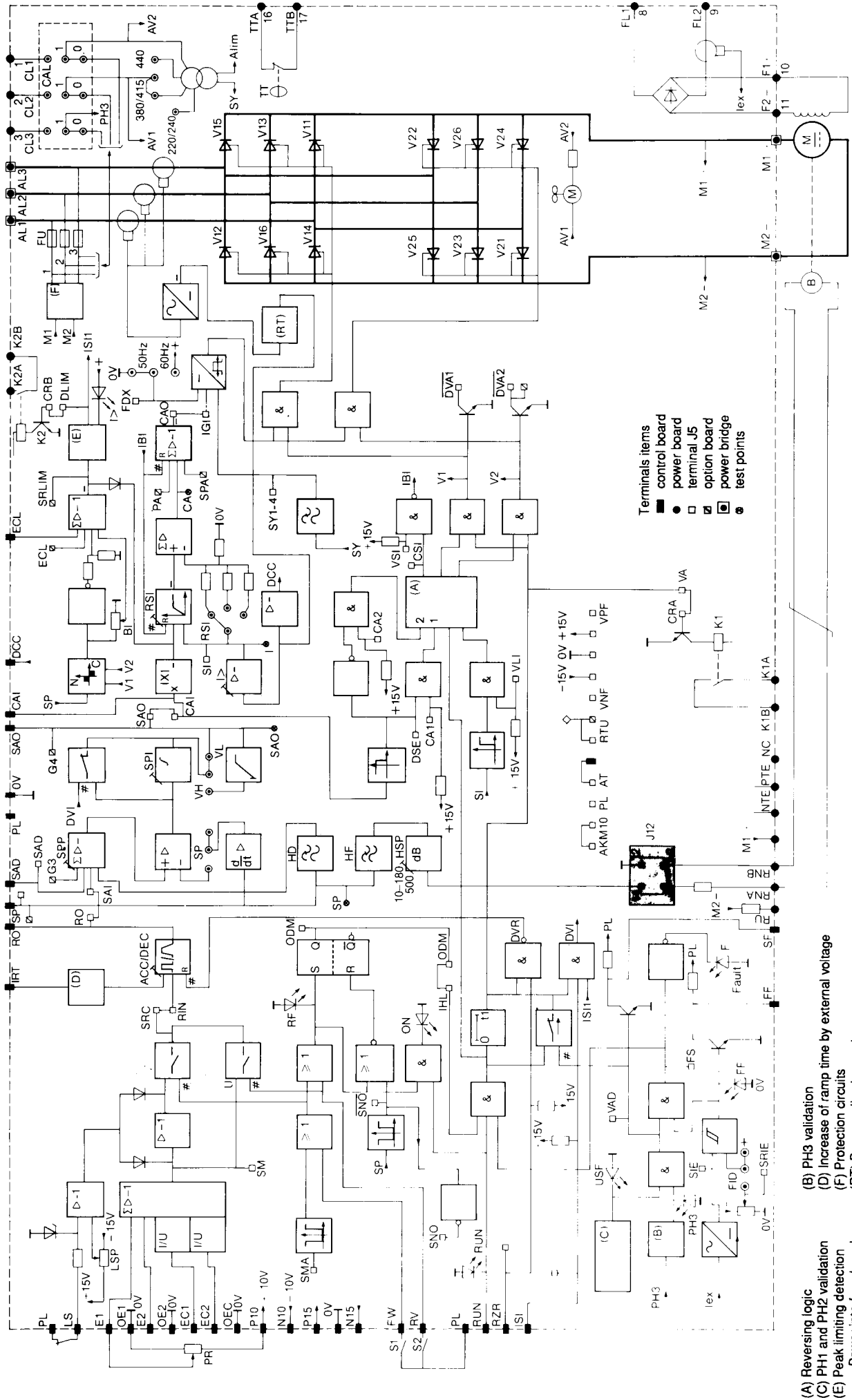

Terminals items
 ■ control board
 ● power board
 □ terminal J5
 ▣ option board
 ▤ power bridge
 ○ test points

- (A) Reversing logic
- (B) PH3 validation
- (C) PH1 and PH2 validation
- (D) Increase of ramp time by external voltage
- (E) Peak limiting detection
- (F) Protection circuits
- (RT) Personalisation package
- Power interface board

NOTE: for the power and ventilation part, the diagram shown is that of RTV-641C15 and C25.

Block diagram of controlled field part for ratings $\geq 800A$

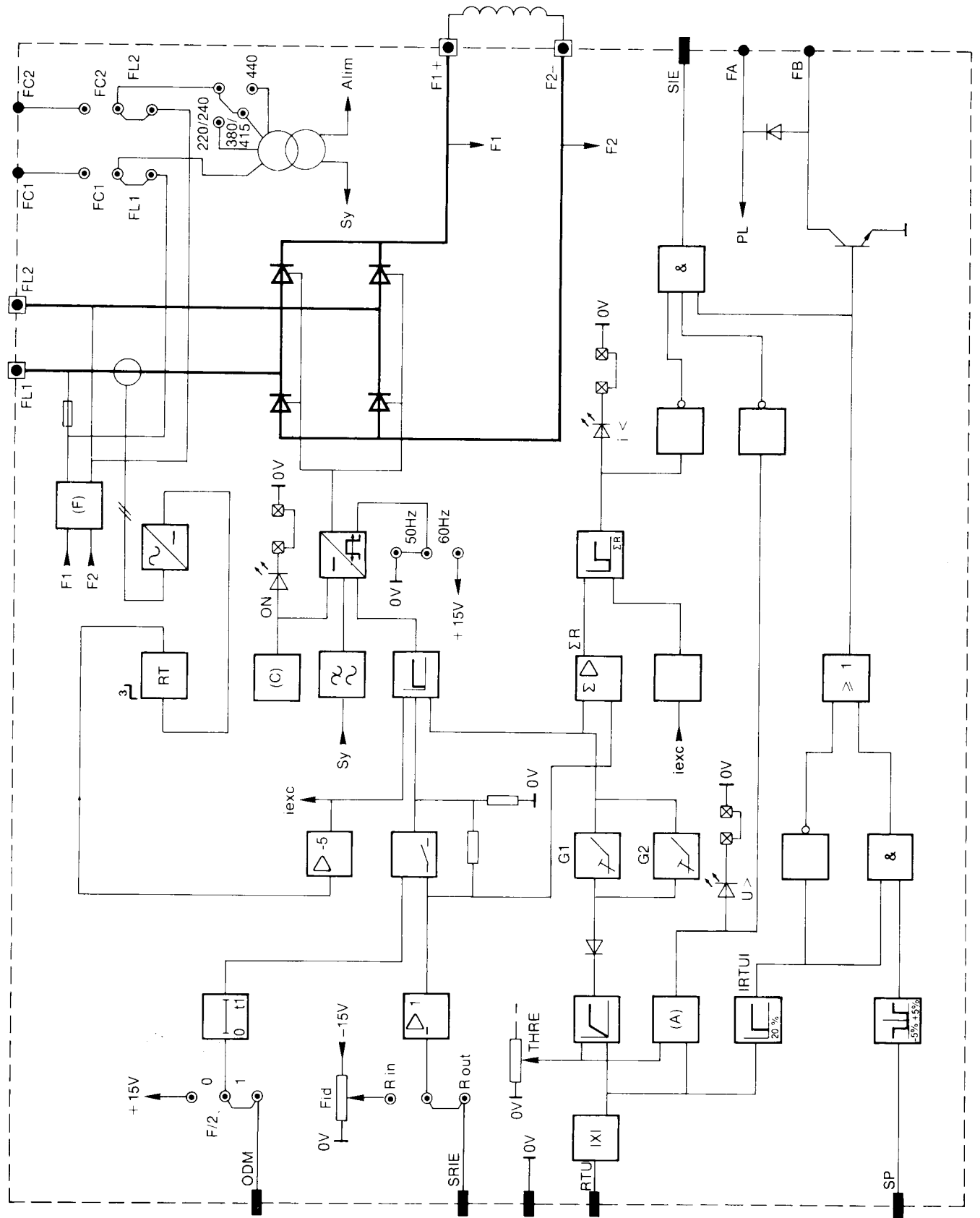

Terminals:

- Power bridge
- Power interface board
- Links with the RTV control board