

KOBOLD Model DF Flow Sensor

User Instructions

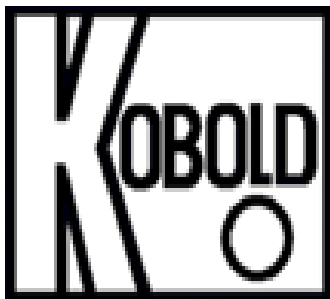

Kobold Instruments Inc. • 1801 Parkway View Drive • Pittsburgh PA 15205

Phone 1-800-998-1020 • Fax (412) 788-4890 • www.kobold.com

DF-SEN_manual_12/13

Table of Contents

1.0	General	1
2.0	Specifications.	2
3.0	Installation Instructions.	5
4.0	Operation.	6
5.0	Arrival of Damaged Equipment	7
6.0	Maintenance.	7
7.0	Need Help with your DF Flow Sensor?	7

List of Diagrams

Diagram 2.4:	Sensor Dimensions	4
Diagram 3.1:	Wiring	5

List of Tables

Table 2.1:	Material Combinations and Maximum Limits.	2
Table 2.2:	Electrical Data	3
Table 2.3:	Flow Ranges and Fitting Sizes	3

KOBOLD Model DF Flow Sensor User Instructions

CAUTION: For safety reasons, please read the cautionary information located at the end of the manual, before attempting installation.

1.0 General

The KOBOLD DF flow sensor is intended for use in applications where flow measurement is desired and the flow rate data needs to be transmitted as a pulse rate output. The DF sensor contains a flow transducer which transmits a 0-100 Hz (nominal) signal. This output frequency is linearly proportional to the flow measured by the instrument and is transmitted by a bipolar transistor operating in an open collector configuration.

The DF uses a paddle wheel to determine flow. The principle of operation is quite simple; the paddle wheel rotation speed is calibrated for the maximum flow rate. This rotation-flow relationship is linear in theory. In practice, theory is nearly borne out, leading to a very precise measuring device. Any non-linearity is within the stated measurement error of the device.

The paddle wheel approach to flow measurement has the advantage that the instrument may be installed in both vertical and horizontal orientations (the axle, however, must remain in a horizontal plane). Further, this measurement technique is relatively insensitive to dirt in the medium (large quantities of ferritic contaminants, however, must be avoided).

2.0 Specifications

Table 2.1: Material Composition & Operational Limits

Material Combination	I	II/IIB *	III	IV *	VI *	VII *
Fittings	NPT	NPT	NPT	NPT or FLANGE	NPT	NPT or FLANGE
Housing	Trogamid®	Polysulfone/PP	NP-Brass	SS	NP-Brass	SS
Window	Trogamid®	Polysulfone/PP	Polysulfone	Polysulfone	NP-Brass	SS
Fittings	NP-Brass	SS/PP	NP-Brass	SS	NP-Brass	SS
Locking Pins	Brass	Brass	Brass	-	-	-
O-Rings	Buna-N	FKM	Buna-N	FKM	Buna-N	FKM
Paddle Wheel	POM	PTFE	POM	PTFE	POM	PTFE
Axle	SS	SS/ Ceramic	SS	SS	SS	SS
Axle Bearing	PTFE	PTFE	PTFE	PTFE	PTFE	PTFE
Orifice	PTFE ²	PTFE ²	PTFE ²	PTFE ²	PTFE ²	PTFE ²
STANDARD VERSION					HIGH PRESSURE VERSION	
Maximum Pressure	145 PSIG	145/85 PSIG	230 PSIG	230 PSIG	1450 PSIG	1450 PSIG or 580 PSIG with flange
Maximum Media Temperature	145°F	180°F	180°F	180°F	180°F	180°F

* Fittings not Rotatable

² SS on Model DF-XX01

Abbreviations:

PP - Polypropylene

NP - Nickel Plated

Table 2.2: Electrical Data

Power Supply:	+5 to +24 VDC
Open Collector Output:	+5 to +24 VDC @ 10 mA max.
Operating Temperature Range:	-10° F to 180° F (+145° F for DF-01..)
Environmental Protection:	NEMA 4

Table 2.3: Flow Ranges & Fitting Sizes

Sensor Model Number	Range Water GPM	Standard Fittings NPT	Special Fitting Suffix "B"	Orifice Diameter Inches	Pressure Drop PSI
DF-XX01	0.02 - 0.14	1/8"	1/4"	0.04	10.2
DF-XX02	0.05 - 0.30	1/4"	3/8"	0.08	4.2
DF-XX03	0.05 - 0.60	1/4"	3/8"	0.08	10.4
DF-XX04	0.1 - 0.7	1/4"	3/8"	0.11	9.6
DF-XX05	0.2 - 2.5	3/8"	1/2"	0.11	12.1
DF-XX06	0.4 - 5.0	1/2"	3/4"	0.32	2.9
DF-XX07	0.5 - 6.0	3/4"	1"	0.32	4.4
DF-XX08	0.5 - 12	3/4"	1"	0.49	4.4
DF-XX09	1.0 - 25	1-1/4"	1-1/2"	0.49	15.9
DF-XX10	1.5 - 36	1-1/4"	1-1/2"	0.73	13.5

Diagram 2.4: Sensor Dimensions

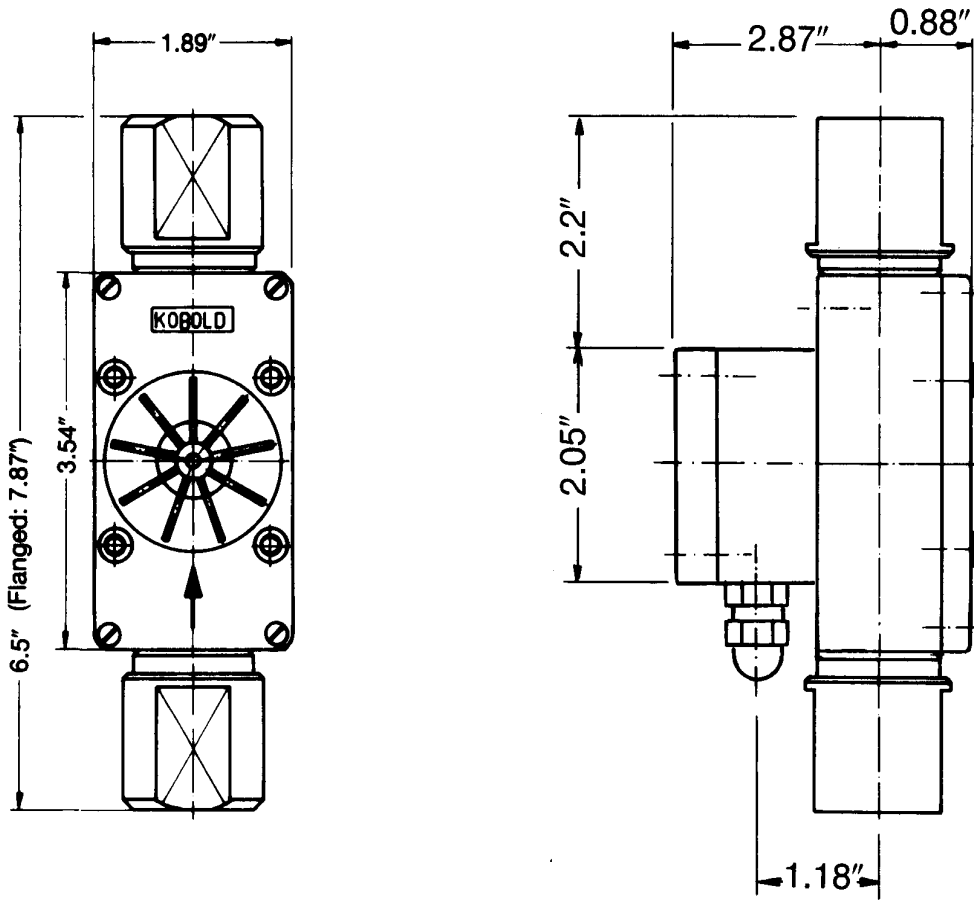

3.0 Installation Instructions

CAUTION: For safety reasons, please read the cautionary information located at the end of the manual, before attempting installation.

To install, proceed as follows:

1. Make sure that the actual flow rate in your system lies within the flow range of the instrument. The flow range can be read off the identification tag. Flow rates in excess of 120% of the range maximum will, in continuous use, lead to bearing and/or paddle wheel damage.
2. Ensure that the power supply voltage is in accordance with that specified on the identification tag. Electrical connections are made with a 3-pin terminal block as specified by the wiring diagram (Diagram 3.1).
3. If the sensor is to be used to provide a voltage pulse output, a sourcing output pull-up resistor **MUST** be connected between the supply voltage terminal and the open collector output terminal (pins 1 and 3). This resistor should be sized such that the collector to emitter current is nominally limited to 5 mA or less during the transistor "on" state. Under no circumstances should the collector to emitter current be allowed to exceed 10 mA.

Diagram 3.1: Wiring

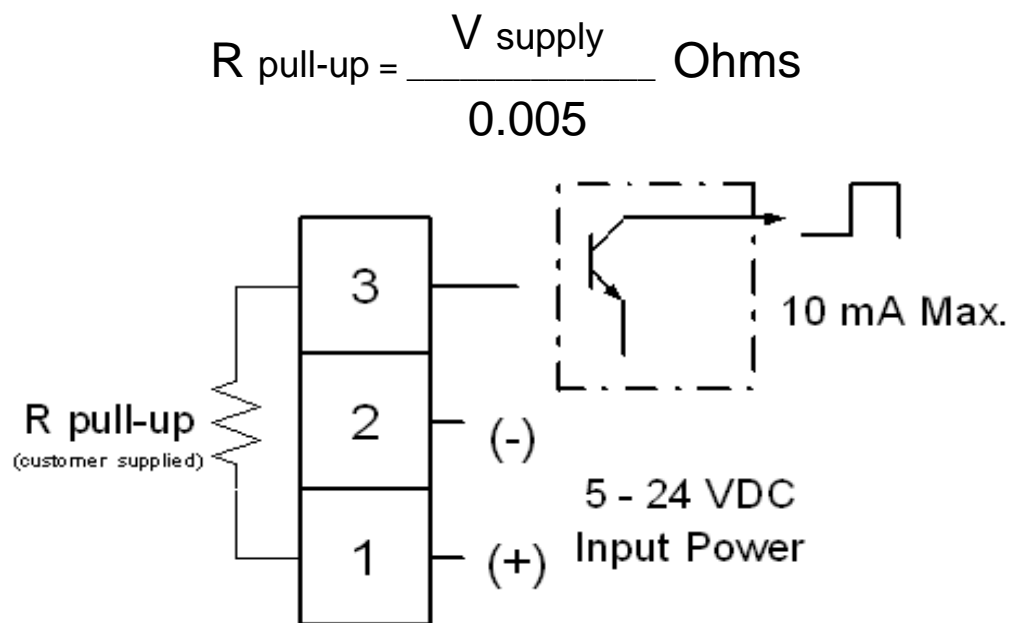

If you have an OEM version (supplied without terminal box), a connector with three wires will be visible. Depending on the color combination of wires your sensor has, attach these as follows:

Blue	- (-) Ground	or	Blue	- (+) VDC
Yellow	- Open Collector		Yellow	- Open Collector
Red	- (+) VDC		Green	- (-) Ground

You are now ready to mechanically connect the unit.

1. The flow direction is indicated by an arrow on the housing. Install the instrument with the arrows aligned with the flow direction in your pipes. To achieve the operational design accuracy, output consistency over the entire measuring range and longest service life, orient the unit so that the axle always remains in a horizontal plane.
2. Connect with appropriately sized fittings. Take care not to place stresses on the housing - use a wrench to hold the instrument fittings static while you tighten the fittings on your pipe. As with any flowmeter, this device must not be used as a structural member of the piping system to avoid damage.
3. Should there be small amounts of ferrite contaminants in the medium, we recommend the installation of our magnetic filter (type MFR or equivalent).
4. Medium should always be introduced to the system slowly to avoid pressure surges which could damage the instrument.

4.0 Operation

The device is delivered with a calibration diagram describing its frequency versus flow rate behavior. You must use this to calculate rate of flow in your system. Modification of the sensor (by physically modifying or replacing sensor components) requires recalibration of the unit.

4.1 - Turning the Unit On

The sensor is operational as soon as it is wired into a power supply.

4.2 - Flow Measurement

A frequency counting device must be used to read the sensor output and convert that measurement to rate of flow (output frequency is directly proportional to flow rate). The nature of this relationship is described by the sensor's "k-factor" which is the number of pulses the sensor generates per gallon of water flow through the sensor. The device's nominal k-factor can be easily calculated with the use of the provided output frequency (in Hz) and knowing the maximum flow rate of the particular sensor.

5.0 Arrival of Damaged Equipment

Your instrument was inspected prior to shipment and found to be defect-free. If damage is visible on the unit, we advise that you carefully inspect the packing in which it was delivered. If damage is visible, notify your local carrier at once, since the carrier is liable for a replacement under these circumstances. If your claim is refused, please contact Kobold Instruments for further advisement.

6.0 Maintenance

The KOBOLD DF sensor requires little maintenance provided the measured medium is kept free of contaminants. In particular, ferritic pollutants can cause problems for this device due to the incorporation of magnets into the paddle wheel. To avoid this, we recommend the installation of a magnetic filter, such as KOBOLD's model MFR or equivalent.

DO NOT tamper with the electronics as this voids your warranty.

7.0 Need help with your DF Flow Sensor?

Call one of our friendly engineers at 412-788-2830.

Caution

PLEASE READ THE FOLLOWING GENERAL FLOW METER/ MONITOR WARNINGS BEFORE ATTEMPTING INSTALLATION OF YOUR NEW DEVICE. FAILURE TO HEED THE INFORMATION HEREIN MAY RESULT IN EQUIPMENT FAILURE AND POSSIBLE SUBSEQUENT PERSONAL INJURY.

- Inspect instrument for damage upon arrival. Cracked, fractured, bent or otherwise damaged instruments must not be put into use, since the device is weakened to an unknown extent. (The operations and installation guide will explain how to make a claim on damaged instruments.)
- Under NO circumstances must the maximum tolerances (temperature and pressure) be exceeded.
- The maximum tolerances of the device have been determined using water, air and/or oil. If using other media, especially corrosive ones, it is critically important that the user determine chemical compatibility with our instruments. A list, detailing material composition of our instruments, is available from KOBOLD Instruments Inc. upon request. KOBOLD Instruments Inc. cannot accept responsibility for failure and consequences resulting from use of media other than water, mineral oil, air, and nitrogen.
- Install the device in a fully supported position within your flow system. This avoids excessive stresses which may damage the instrument. In particular:
 - a. Ensure that the plumbing leading to and from the instrument is fully supported and that the instrument does not perform the physical function of a joint.
 - b. When calculating stress on the device caused by plumbing, the weight of the medium in the pipes must be considered as well.
 - c. Misaligned runs of rigid piping can cause large stresses when connected to the instrument. Do not connect in such a fashion.
- During installation, avoid stresses on the instrument by following guidelines given below:
 - a. When connecting fittings, hold the instrument fittings rigid with a correctly sized wrench. Do not install by twisting the instrument into the pipe fittings.
 - b. Do NOT install by holding the device housing to provide counter-torque to the pipe fitting.
 - c. Use an appropriate amount of PTFE tape on male threads of fitting. This reduces the twisting stresses produced by tightening the fittings into each other.
 - d. Do not use pliers or wrenches on the housing, as this may damage it.
 - e. Do not overtighten, as this may fracture the fittings.

- During operation, there are a number of situations to avoid:
 - a. The sudden cessation of fluid flow causes what is typically referred to as "water hammer". Most people are familiar with this phenomenon from their home experience - it is the cause behind the loud clank of water pipes which occurs when faucets are turned off too suddenly. The cause behind this "water hammer" is quite easy to visualize. Water is fairly massive. The amount of water in long runs of pipe is quite substantial. When the faucets are turned off suddenly, especially from a full on condition, the water has considerable momentum and does not want to stop flowing. The situation is similar to stopping a car by running into a wall, rather than by applying brakes. Both are sudden rather than gradual. The damage to the wall can be substantial (not to mention the car).

The "water hammer" causes surges in fluid pressure which could cause the measurement instrument's pressure limit to be exceeded, resulting in failure and possible personal injury.

- b. Fluid surges, as well as the water hammer, can be particularly damaging to empty flowmeters since there is no back pressure in the device. The damage is caused, once again, by momentary excess pressure. To avoid these surges, fluid lines should remain full (if possible) and water flow should be introduced to the device slowly.
- c. If the instrument is isolated with inlet and outlet valves, the instrument must be completely drained when said valves are both closed. Failure to do so could result in damage to the device caused by thermal expansion of fluid.
- d. Freezing of water in the instrument **MUST** be avoided since the resultant expansion will damage the instrument and make it unsafe for use.