

Power Drive

# WS5-9

Doc. no. 211.367/DGB 03.96

Ident. no.: 00441109330

Edition: b023 March 96

**SIG Positec BERGERLAHR GmbH&Co.KG**

Breslauer Str. 7  
Postfach 1180

D-77901 Lahr

**Suggestions  
Corrections**

**WS5-9  
Power Drive**

Issue: b023 March 96  
Doc. no. 211.367/DGB 03.96

**Sender**

Name:

Company / Dept.:

Address:

Phone:

If you have found any faults within this documentati-  
on, or have any suggestions, we cordially invite you  
to inform us on this form.

**Suggestions and/or Corrections**

## Safety requirements

Please read the following safety requirements prior to installation, operation, maintenance and repair of the device.

- The intended use of the device is described in this manual in chapter "Purpose" and must be observed.
- Installation, maintenance and repair of the device shall be performed by a qualified electrician. National regulations concerning
  - accident prevention
  - installation of electrical and mechanical systems
  - radio interference suppressionshall be observed.
- The technical data of the device, particularly the ambient conditions, shall be observed.
- The device shall only be operated by trained personnel. BERGER LAHR offers training courses.
- The warranty is invalidated in case of unauthorized modification or opening of the device.
- Please ask your BERGER LAHR technical consultant prior to installing accessories not listed in the chapter "Description of accessories". The address is to be found on the rear cover.
- The safety symbols and notes on the device and in the manual shall be observed.

## Explanation of symbols



### **ATTENTION**

*Reference to a danger for the device or components, possibly resulting in the endangering of human life.*

### **DANGER**

*Reference to a direct endangering of human life.*



### **DANGER**

*High voltage at component, do not touch.*



### **DANGER**

*High temperature at component, do not touch.*



### **ATTENTION**

*Warning against electrostatic discharge (ESD).*

*Only touch the PC-board or component in an electrostatically-protected environment.*



### **NOTE**

*Important or additional information concerning the device or the manual.*



	Page
<b>1 General Description</b>	<b>1-1</b>
1.1 Construction and Characteristics	1-1
1.2 Application/System Integration	1-2
1.3 Function	1-3
1.4 Technical Data	1-4
1.4.1 Electrical Data	1-4
1.4.1.1 Mains Connection	1-4
1.4.1.2 Motor Connection	1-4
1.4.1.3 Signal Connection	1-4
1.4.1.5 Equipment Protection	1-5
1.4.2 Mechanical Data	1-6
1.4.3 Ambient Conditions	1-7
<b>2 Installation</b>	<b>2-1</b>
2.1 Parts Specification	2-1
2.2 Accessories	2-2
2.3 Mounting	2-2
2.4 Cabling	2-3
2.4.1 General Instructions	2-3
2.4.2 Connection of the Motor	2-4
2.4.3 Adjustment of the Equipment to Mains Voltage	2-6
2.4.4 Connecting of the Mains Cable	2-6
2.4.5 Connecting the Signal Cables	2-7
2.5 Initial Operation	2-10
2.5.1 Checklist for Initial Operation	2-10
2.5.2 Basic Settings	2-10

# Table of Contents

---

<b>3</b>	<b>Operation</b>	<b>Page</b> <b>3-1</b>
3.1	Signal Description	3-1
3.1.1	Input Signals	3-1
3.1.2	Output Signals	3-5
3.2	Switching On	3-6
3.3	Operating Facilities	3-6
3.4	Switching Off	3-6
<b>4</b>	<b>Errors / Faults</b>	<b>4-1</b>
4.1	Status Indicator	4-1
4.2	Troubleshooting Table	4-2
4.3	Storage and Shipping	4-3
<b>5</b>	<b>Maintenance</b>	<b>5-1</b>
<b>6</b>	<b>Appendix</b>	<b>6-1</b>
6.1	Equipment Variants	6-1
6.2	Description of Accessories	6-1
6.2.1	Motor Cable	6-2
6.2.2	Mains Filter	6-3
6.2.3	Signal Cable	6-3
6.3	Glossary of Technical Terms	6-5
<b>7</b>	<b>Index</b>	<b>7-1</b>

# 1 General Description

## 1.1 Construction and Characteristics

### Construction

The power drive WS5-9 has the following components (Figure 1-1):

- *Current selection switch* for selecting the motor phase current;
- *Parameter switch* for selecting the functions: current zero-setting, boosting, current reduction, rotation direction, step angle;
- *Voltage switch* between 115 V AC and 230 V AC;
- *LED display* for signalling of faults;
- *Signal connection* for driving of the power unit;
- *Motor connection* for a 5-phase stepping motor;
- *Mains connection* for the power supply (115 / 230 V AC);
- *Fasteners* at the back of the equipment for fixing to mounting rails.

### Characteristics

The power drive WS5-9 has been designed to be fixed to a mounting rail, i.e.:

- the equipment can be fixed to a mounting rail (TS 35 x 15) by means of the fasteners.
- all the operating controls, indicators and connections are located on the front panel of the equipment.



### NOTE

Because the WS5-9 is designed for an IP 20 degree of protection, the equipment must be incorporated in a switch cabinet or in another enclosed housing.

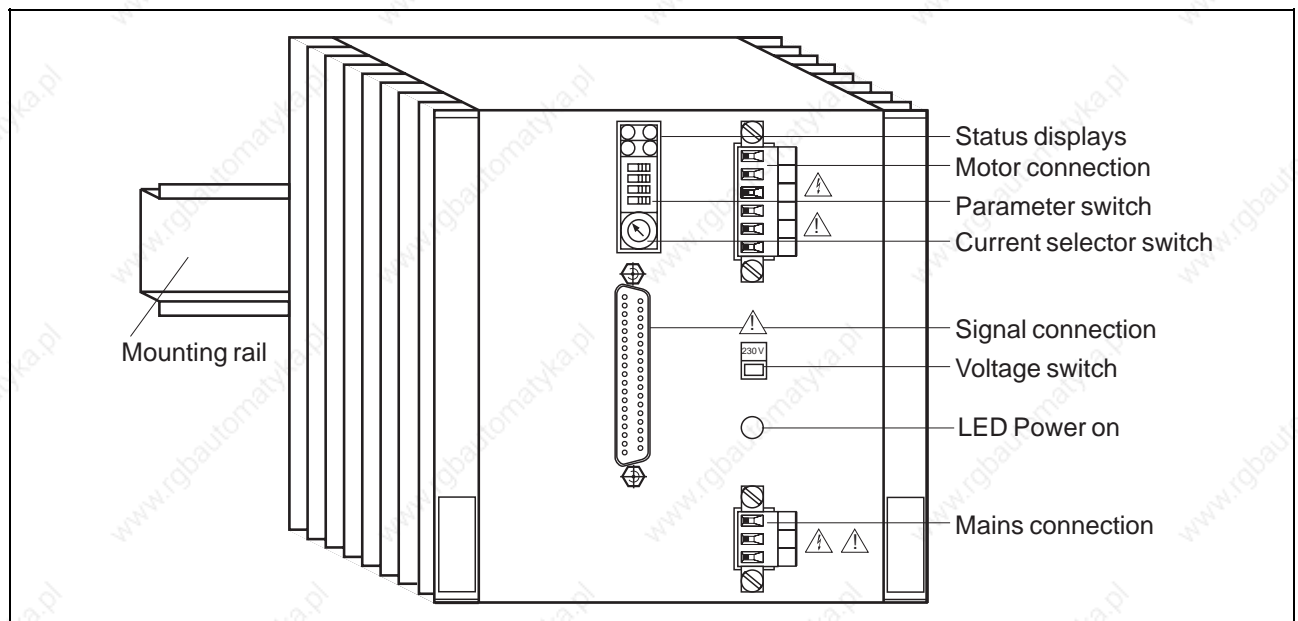

Figure 1-1 Power Drive WS5-9

## General Description

### Other characteristics include:

- Operation with mains power supply;
- Short-circuit protection of the power stage when there is shorting between motor phases or between motor phase and earth;
- Undervoltage, excessive temperature and phase monitoring of the power stage.

## 1.2 Application/System Integration

The purpose of the WS5-9 drive is to drive a 5-phase stepping motor up to a current of 2.8 A (70 V DC). It is the link between a positioning controller (e.g. WP-311) or an SPC unit with indexer and the stepping motor (Figure 1-2).

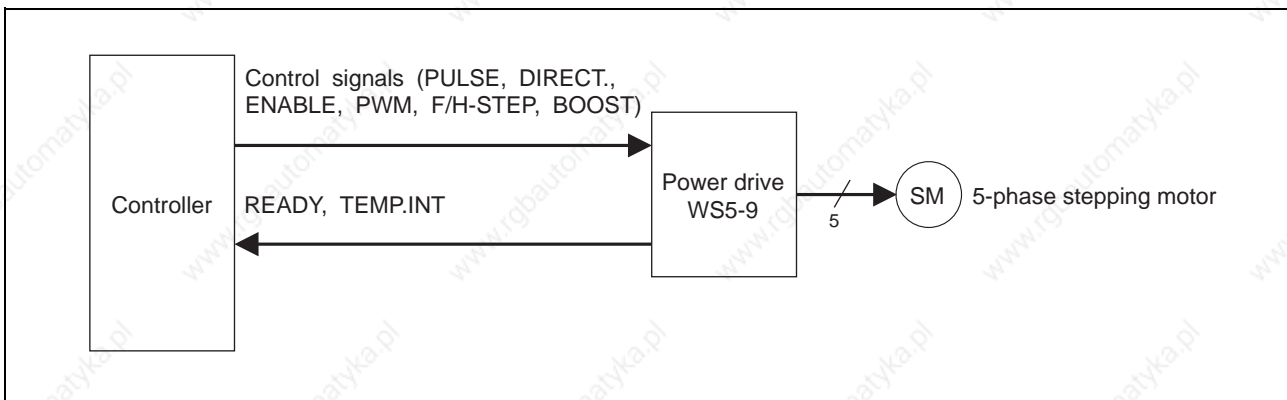

Figure 1-2 System integration

### Motor types

The power drives of the WS5 series are designed for 5-phase stepping motors up to a maximum rated current of 2.8 A per winding.



#### NOTE

The 5-phase stepping motors are operated in five-point connection (see page 2-4).



### 1.3 Function

Figure 1-3 shows the most important function blocks of the unit:

- From the mains voltage of 230 V AC or 115 V AC the *intermediate circuit voltage* of 70 V DC is generated in the power unit.
- The *chopper-type power supply unit* provides the supply voltages for the internal modules.
- The *parameter switches* are used to make the basic settings for phase current, direction rotation and step angle (see section 2.5).
- The "*control electronics - power stage - current controller*" closed-loop circuit converts the PULSE and DIRECT. input signals into the output signals for driving the stepping motor. The *control electronics* block contains the *ring counter logic* which defines the current pattern. The current controller keeps the phase current constant at the preset value.
- The status of the equipment is recorded in the *Monitoring and Protection* block. Any possible errors are signalled externally via the fault indicator and via the READY signal output (see sections 3.1.2 and 4.1).

For more details about the meaning and function of the various control signals, see section 3.1

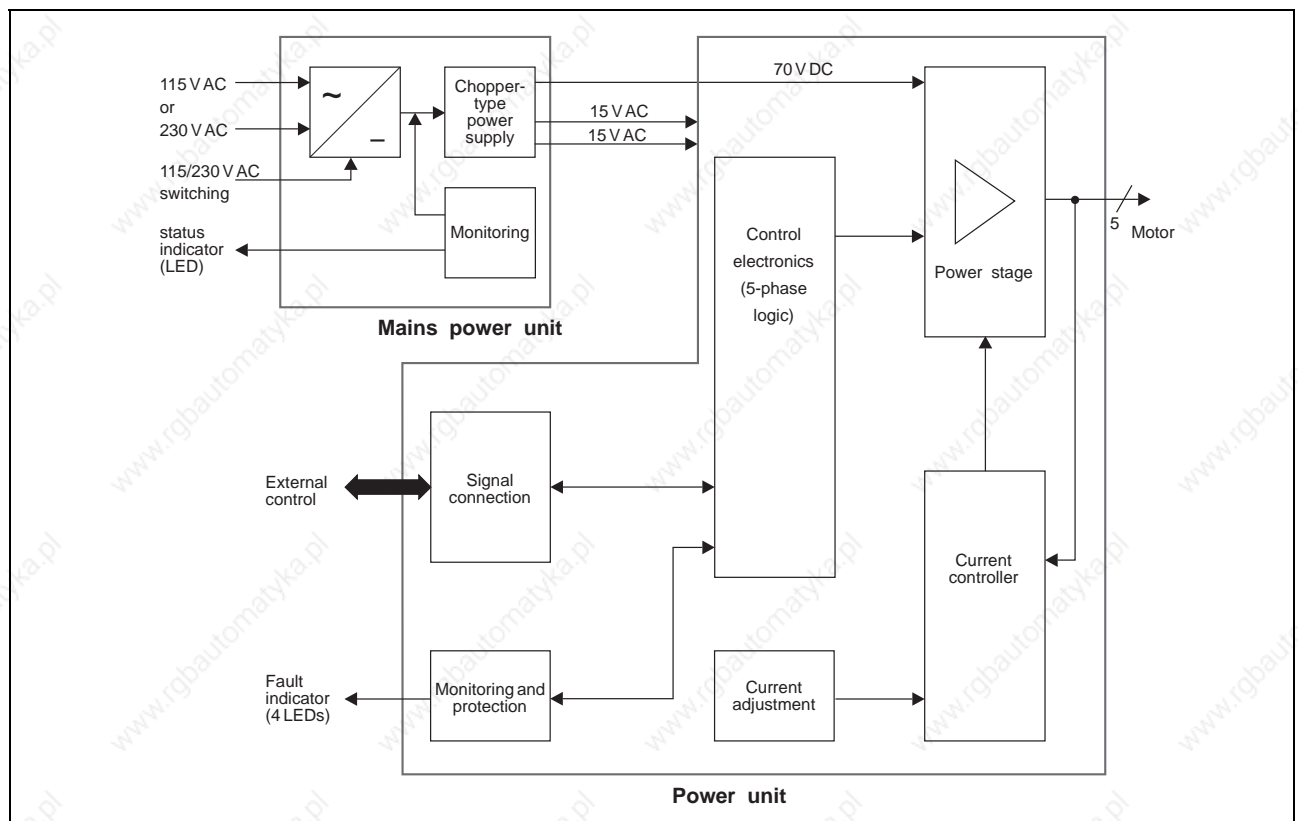

Figure 1-3 Function connection diagram of WS5-9

# General Description

---

## 1.4 Technical Data

### 1.4.1 Electrical Data

#### 1.4.1.1 Mains Connection

Mains connection voltage, switchable to:	115 V AC, -20% +15% 230 V AC, -20% +15%
Current at make	30 A
Fuse	6.3 A slow-blow
Frequency	50-60 Hz
Power consumption	max. 600 VA
Power dissipation	max. 80 W

#### 1.4.1.2 Motor Connection

Protected in case of short-circuit between motor phases	
Max. cable length	50 m
Cable diameter	0.75 mm <sup>2</sup> for cable length ≤30 m 1.5 mm for cable length >30 m
Screen connection	both sides
Motor voltage	70 V DC
Phase current	in 16 stages from 0.55 to 2.8 A
Connection system	five-point

#### 1.4.1.3 Signal Connection

This connection must be safely isolated from the mains.	
Max. voltage (power resistance) to earth	60 V DC
Cable diameter	0.25 mm <sup>2</sup>
Screen connection	the control side only

### Electrical Characteristics of the Inputs PULSE, DIRECT, ENABLE, PWM, F/H-STEP, BOOST

Optocoupled and protected against reverse polarity.  
The signal voltage level is typespecific (see Equipment Variants)

	TTL	or	24 V
Max. input voltage	5.25 V		30 V
Switch on point U <sub>E</sub>	2.5 V		20 V
Switch off point U <sub>A</sub>	0.4 V		3 V
Typical input current at nominal current			10 mA

### Electrical characteristics of the output TEMP.INT

Optoencoupled, protected against reverse polarity, inductive resilient, short circuit protected.

Max. voltage drop $U_R$	28 V
Max. switch current $I_L$	10 mA
Voltage drop at 10 mA	max. 2 V

### Electrical characteristics of the output READY

Relay double-throw contact.

Max. voltage	30 V AC, 36 V DC
Max. current	0,2 A
Min. current	10 mA
Max. active power	5 W
Max. apparent power	6 VA

#### 1.4.1.5 Equipment Protection

Type of protection	IP 20 as per DIN 40050 / IEC 140
Protection class	1
Power unit	shortcircuit- and overvoltage-proof as per VDE 0160 Cl.2
Power stage protection circuits:	Short-circuit monitoring; Excessive temperature recognition; Monitoring of over/undervoltage and motor phase interruption

# General Description

## 1.4.2 Mechanical Data

Dimensions (L x W x H)

135 x 135 x 157 mm

Weight

2.8 kg

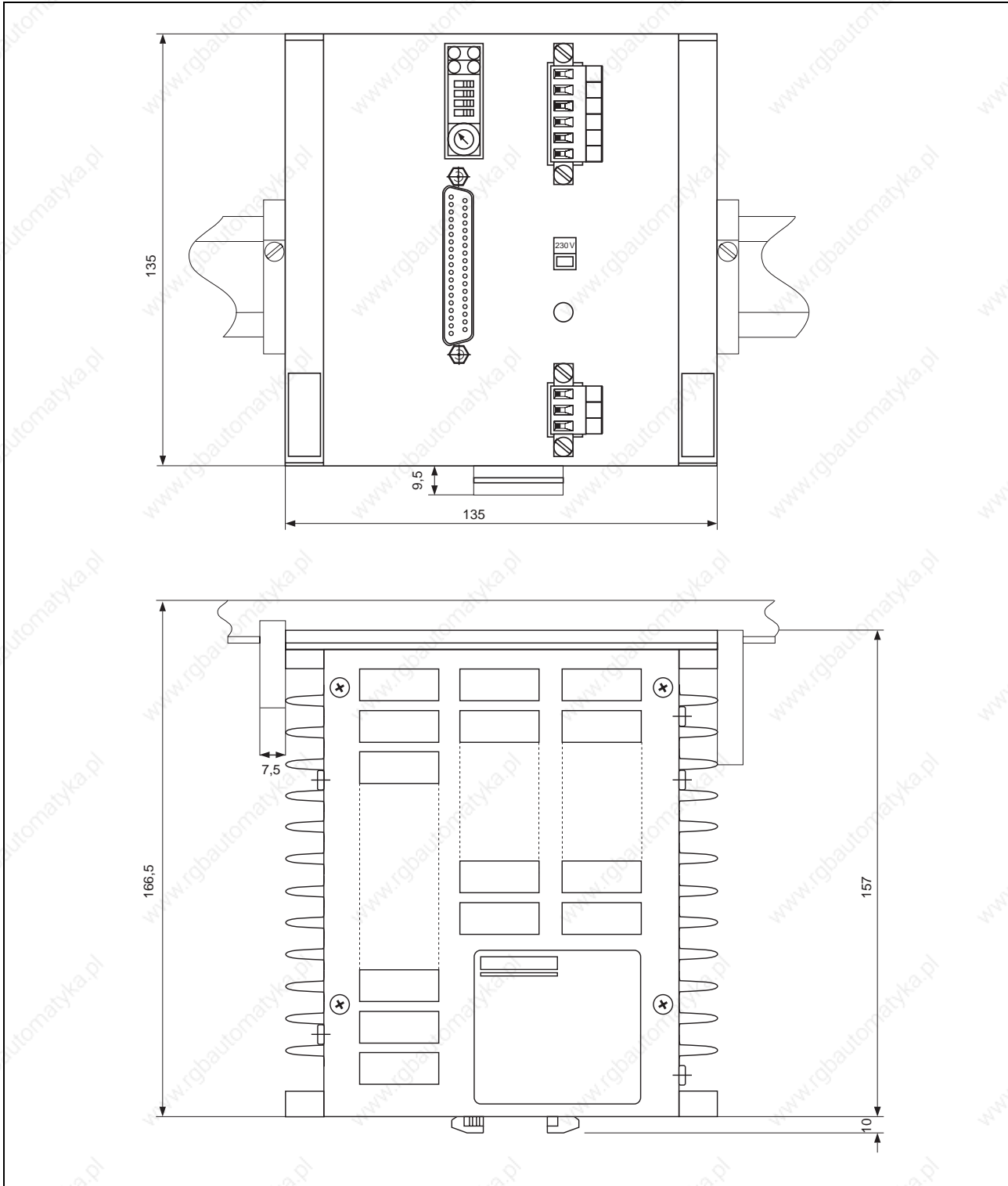

Figure 1-4 Dimensions of the equipment

### 1.4.3 Ambient Conditions

Ambient temperature:	
Working	0°C to 50°C
Storage/transportation	-25°C to 70°C
Change in ambient temperature:	
Working	max. 10 K/h
Storage/transportation	max. 20 K/h
Humidity class - components	F as per DIN 40040
Humidity class tested according to IEC 68 part 2-3 at:	
• air temperature	+40°C, +2°C
• relative air humidity	93%; +2%-3%
Radio shielding	with external filter (type Timonta FF 390) as per VDE 0871-A
Overvoltage stability	as per VDE 0160-2
Resistance to interference	as per VDE 0843 / IEC 801
Dew formation not permitted	



#### NOTE

*When the WS5-9 is mounted in a switch cabinet, it must be remembered that the power loss which can be removed depends on the design of the cabinet, its ambient temperature and the arrangement of the equipment. See section 2.3.*

## **General Description**

---

## 2 Installation

### 2.1 Parts Specification

The specification must be checked for completeness.

The specification includes (Figure 2-1):

Q'ty	Description	Order number
1	WS5-9.081-00 (24 V) or WS5-9.181-00 (3.5...5 V)	64690810006 or 64691810006
1	Plug shell Mains connection	98050060642
1	Plug shell Motor connection	98050060600
1	Sub-D socket (37 pole) for signal connection	N4-673-203
1	Housing for Sub-D socket (37 pole) for signal connection	N4-673-239
1	WS5-9 Technical documentation	Doc. no. 211.367/DGB

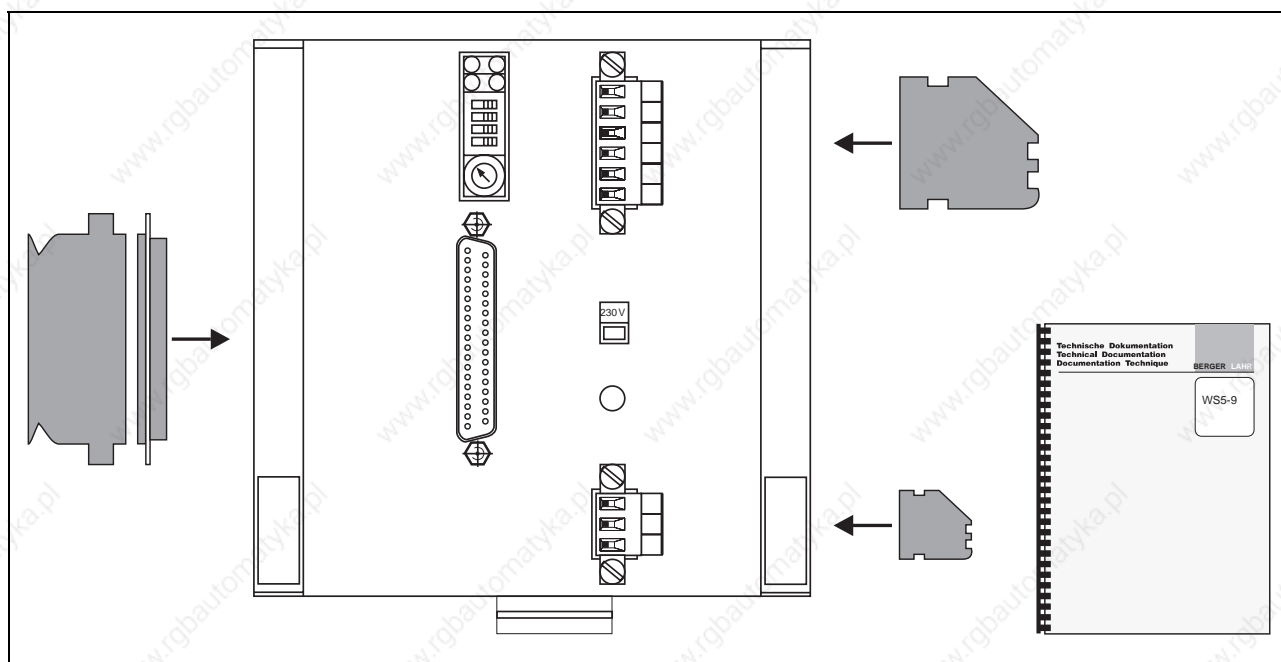

Figure 2-1 Parts specification

# Installation

## 2.2 Accessories

The following accessories can be supplied by special order:

Description	Order number
Signal cable	see Appendix
Motor cable	see Appendix
Stepping motor	see catalogue Doc. no. 350
End bracket EW 35	038356 from Fa. Weidmüller



### NOTE

For a description of the accessories, see Appendix 6.2

## 2.3 Mounting



### CAUTION

**The WS5-9 must be housed in a switch cabinet so as to ensure resistance to interference and prevent the equipment from being contaminated. Make sure that there are adequate provisions for the dissipation of heat!**

The equipment is fitted to a supporting rail on the mounting wall by means of the fasteners at the back of the equipment and is secured at the sides by the end brackets. The minimum clearance between several WS5 units or from other pieces of equipment must be 10 cm. The outer surfaces of the equipment act as a heat sink to remove the heat. The maximum power dissipation of the equipment is 80 W.

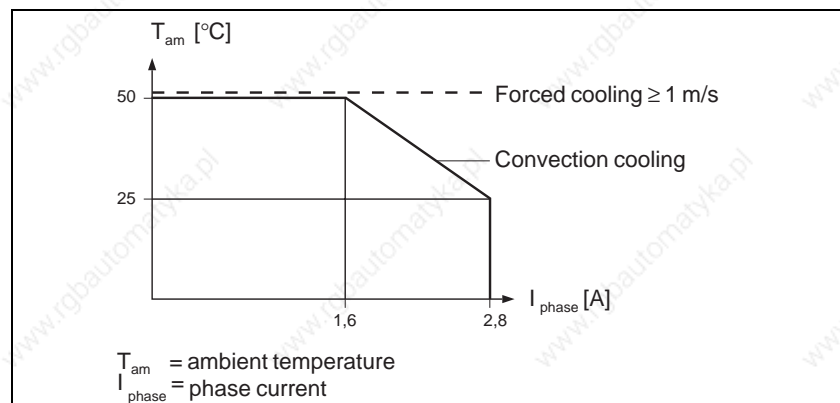

Figure 2-2 Cooling



## 2.4 Cabling

### 2.4.1 General Instructions

All the electrical connections will be made by multi-pole plug connections on the front panel of the equipment (Figure 2-3). Ready-made cables are available as accessories (see section 2.2).



#### **DANGER**

- **Switch off mains voltage before connecting cables!**
- **The power connections (motor, mains) should be carried out only by qualified electrical engineers in accordance with VDE 0105!**



#### **CAUTION**

- **Make sure that the cables are screened and fitted with strain-relief clamps!**
- **Twist every pair of signalling cables before connecting them!**
- **Lay mains, motor and signal cables so that there is a space between them!**

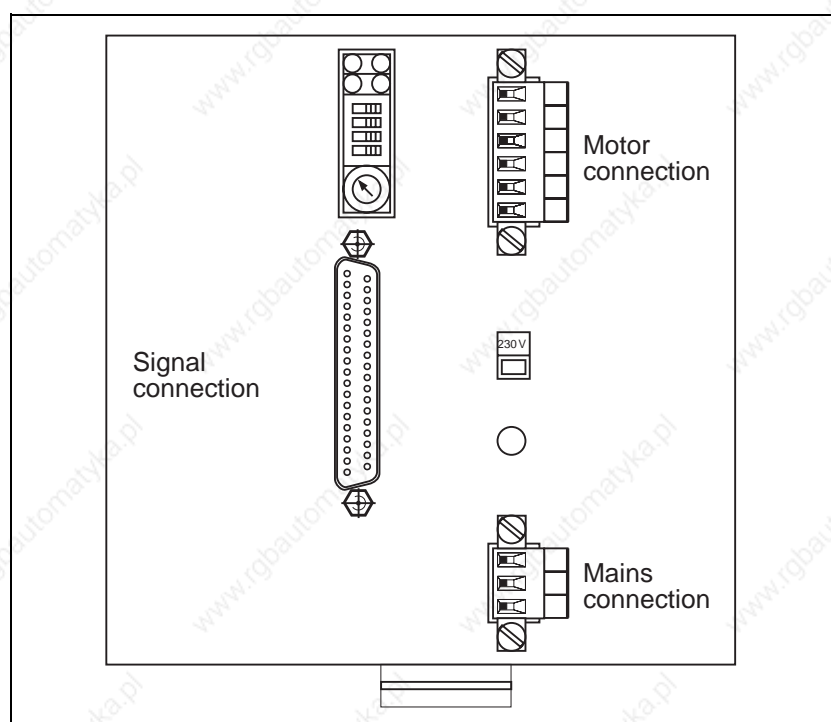

Figure 2-3 Overview of connections

## Installation

### 2.4.2 Connection of the Motor

1. Prepare the 5 wires of the motor cable and the screen which are to be connected to the plug end with boot lace ferrules.
2. Insert the 6 wires into cap of the mating plug as shown in Figure 2-4 and tighten the screws.
3. Join the two plug shell halves together.
4. Set the plug to connection 09 and tighten screws.



#### CAUTION

*To minimise the losses in the cable and the power drive, it is advisable to have as short a cable route as possible. The maximum length of the motor cable is 50 m. For cable diameter, see technical data.*



#### DANGER

*The locking mechanism of the motor plug may only be opened when the mains voltage has been disconnected.*

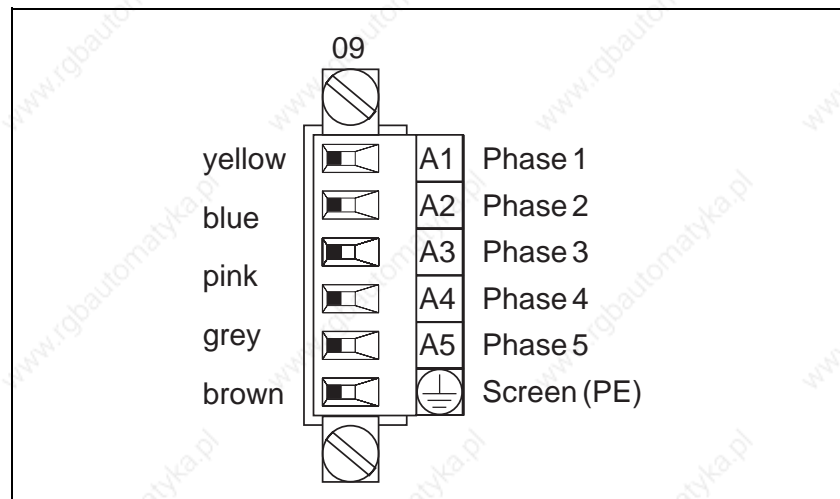

Figure 2-4 Motor connection

## Circuitry of the motor

The circuitry of the motor uses a five-point connection, see Figure 2-5.



### NOTE

*In the five-point circuit twice the phase current flows in the motor connecting wires.*

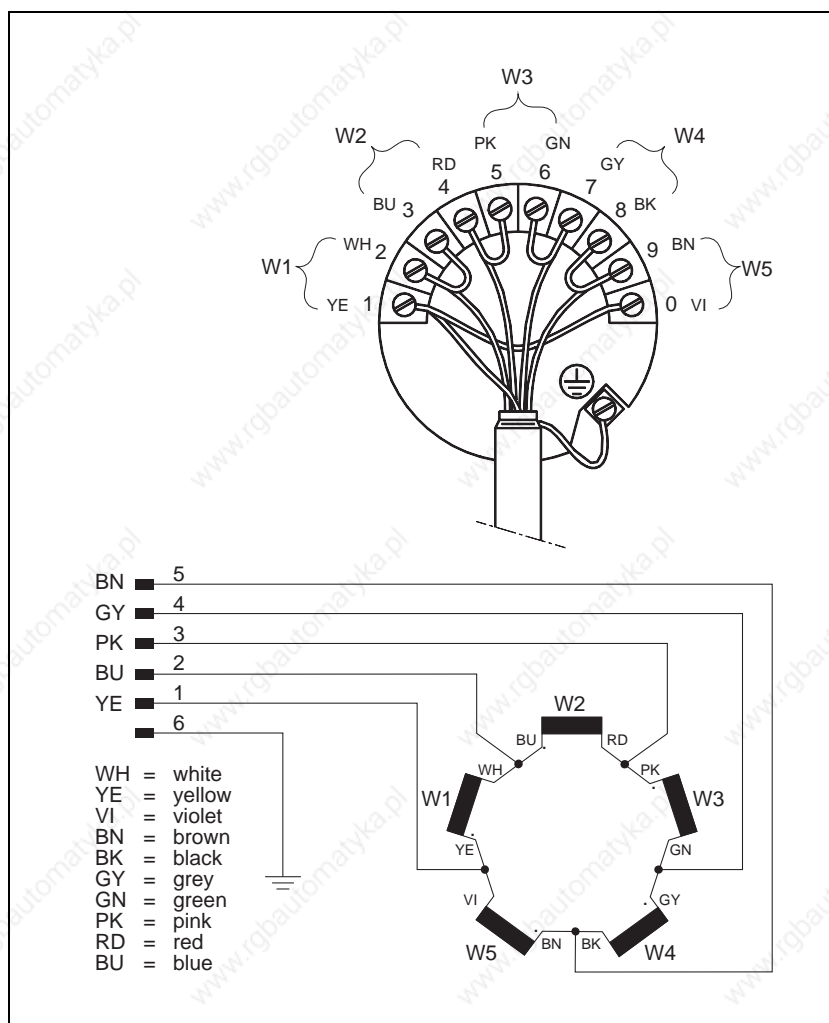

# Installation

## 2.4.3 Adjustment of the Equipment to Mains Voltage



### CAUTION

*The equipment must be set to the normal national mains voltage of 115 V AC or 230 V AC.*

1. Disconnect mains voltage to the WS5-9.
2. Using a screw driver, for example, turn voltage switch 10 into the desired position:  
switch at top: 115 V AC  
switch at bottom: 230 V AC.

The position which has been set is indicated on the switch.



### CAUTION

*The mains voltage must always be turned off before any alteration is made to the position of the voltage switch.*

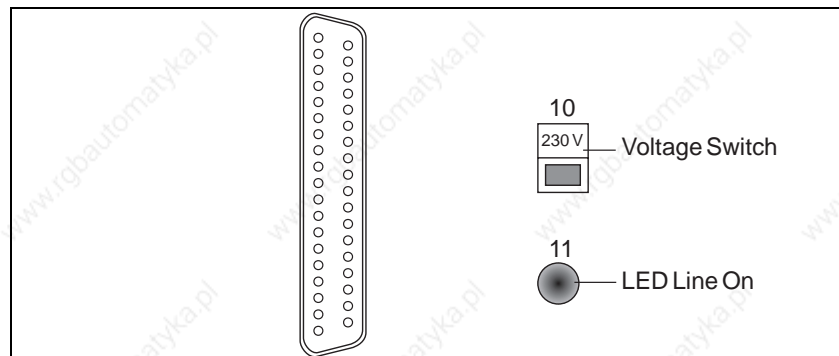

Figure 2-6 Adjustment of the mains voltage

## 2.4.4 Connecting of the Mains Cable

1. Prepare the wires of the mains by fitting boot lace ferrules at the plug end.
2. Insert the 3 wires into mating plug terminal block as shown in Figure 2-7 and tighten screws.
3. Join the plug shell halves together.
4. Set the plug to connection 12 and tighten screws.



### DANGER

*Make sure that the mains voltage is disconnected before loosening the mains cable!*

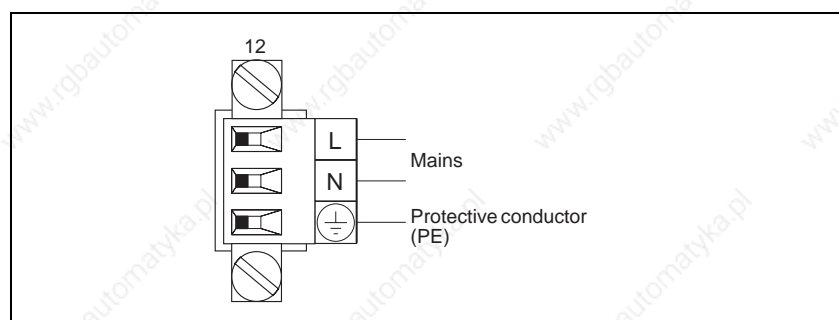

Figure 2-7 Mains connection

## 2.4.5 Connecting the Signal Cables

1. Twist the wires of the signal cables in pairs and solder them onto the 37 pins Sub-D-socket, according to figure 2-8.
2. Insert cable into the cable entry clamp (strain relief) and clamp it. Connect the screen on the side of the control with earth (GND).



### NOTE

When using a push-pull drive, it may be useful to connect the screen to the plug shell on both ends of the cable.

3. Put on socket shell.
4. Plug socket to socket connection panel 04 and tighten screws.



### ATTENTION

- Maximum length of the signal cable: 50 m.
- All signal connections shall be safely isolated from the mains (maximum voltage to earth: 60 V DC).

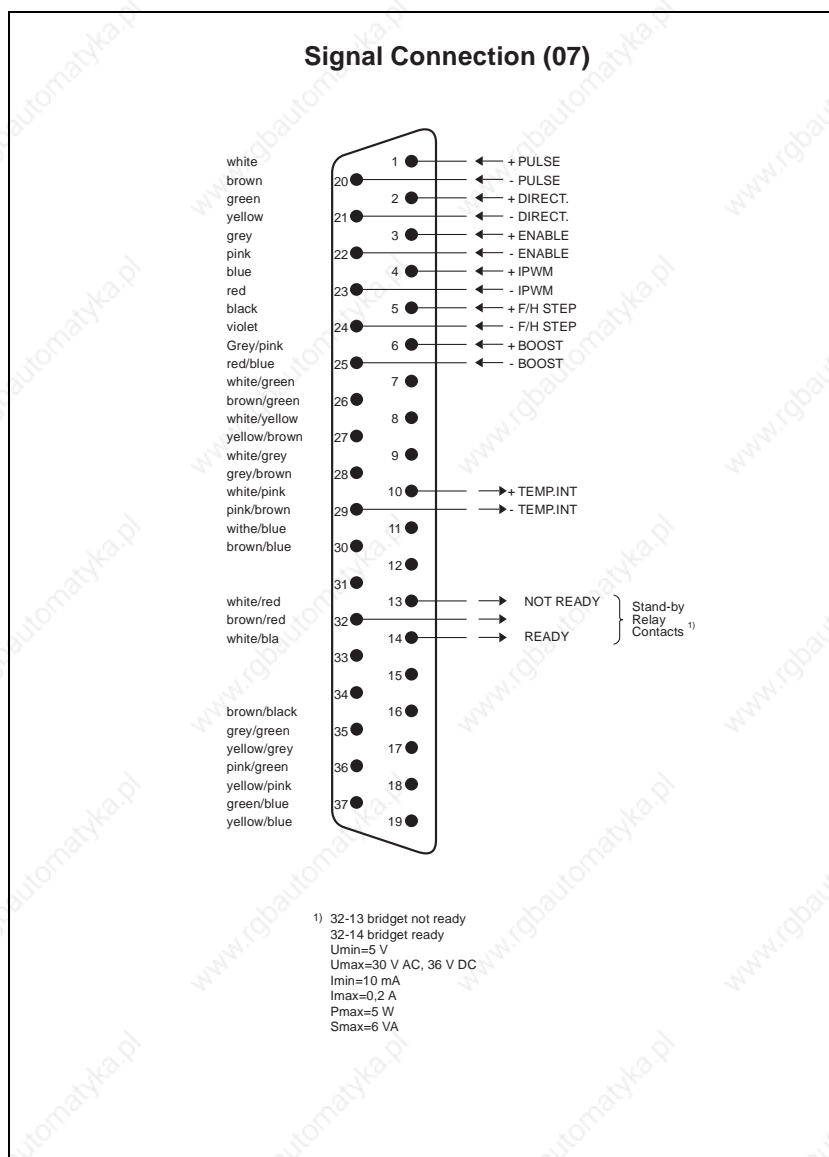

Figure 2-8 Wiring the signal connector

## Circuitry of the signal connections

For the electrical isolation of the signal inputs and outputs optocouplers are used; the internal circuits are shown in figure 2-9.

In the case of an alternating signal voltage level choose the equipment variant with 5 V signal level. Also wire into the external feeder additional protective resistors to ensure a current of approx. 10 mA.

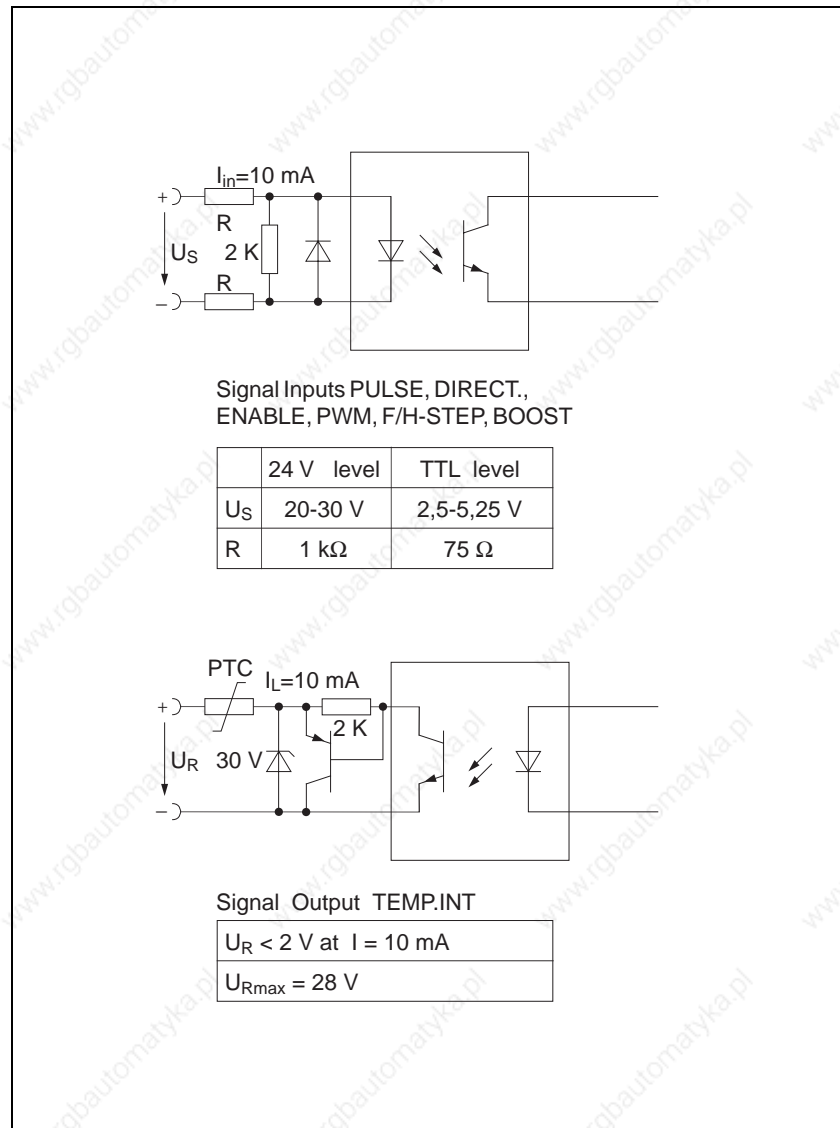
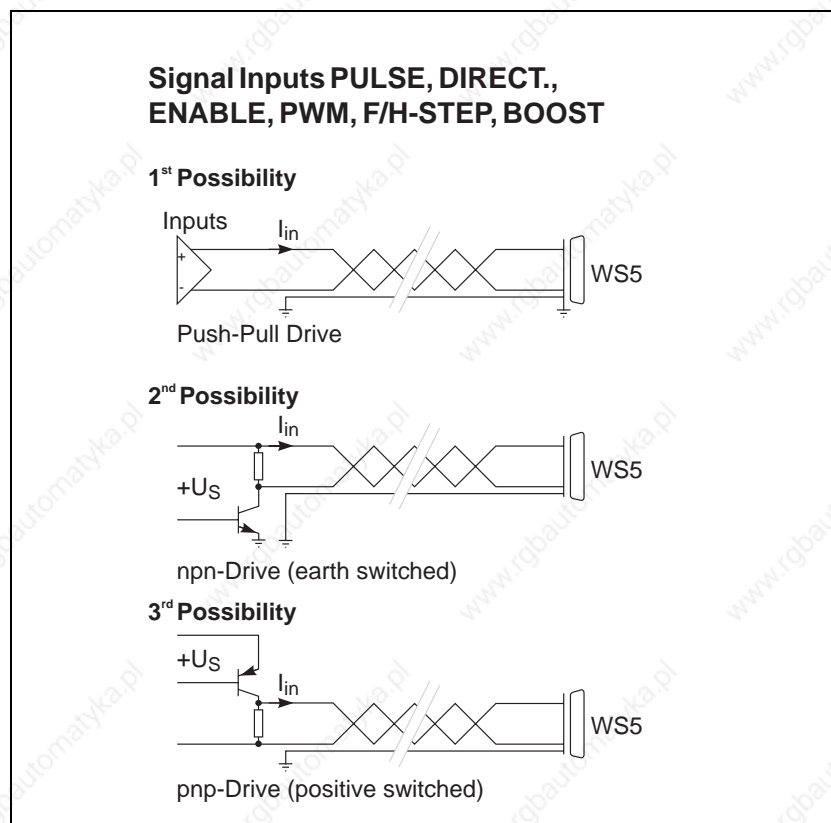

Figure 2-9 Internal wiring

Figure 2-10 shows the possible connections of the signal inputs. The *Push-Pull drive* (which is also used in the BERGER LAHR Positioning Controller) offers the advantage of a higher signal to noise ratio.



*Bild 2-10 External connection possibilities of signal inputs*

# Installation

## 2.5 Initial Operation

### 2.5.1 Checklist for Initial Operation

Before you start to make the basic settings to the equipment, check the following points:

- Has the equipment been correctly installed and fitted (see section 2.3)?
- Is there a reliable ventilation flow to and from the equipment?
- Is the equipment correctly wired and cabled (see section 2.4)?
- Has the equipment been adjusted for the existing mains voltage?
- Have motor and signal cables been laid with a good space between them?

### 2.5.2 Basic Settings

The basic settings are made using the current selector and parameter switch (Figure 2-11) as follows:



**DANGER**

**Disconnect the equipment before starting to make any adjustments!**

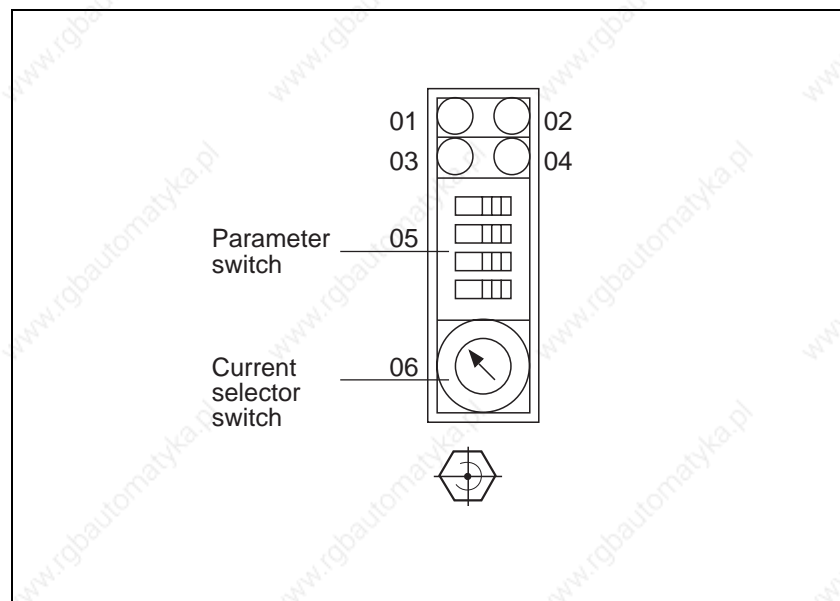

Figure 2-11 Setting elements



## Setting of the phase current

Setting the phase current using rotary switch 06.

For the possible settings, see Figure 2-12. If it is found to be impossible to set the phase current indicated on the rating plate of the motor, set the next lowest value.



### CAUTION

- **Never set too high a current! The maximum phase current must not be exceeded and, if it is, this must be only momentarily (boost signal). This is to prevent overloading of the motor. Make sure the motor is adequately cooled (temperature on motor housing must not exceed 100 °C)!**
- **The phase current must be set to max. 2.65 A for the motors ExRDM 5913/50P and ExRDM 599/50P! Current increase via Boost is not permitted.**



### NOTES

- *Smaller phase currents are permissible, but of course the torque is correspondingly reduced.*
- *To reduce power dissipation, the automatic current reduction system should be switched on when the system is at rest (see Figure 2-13).*

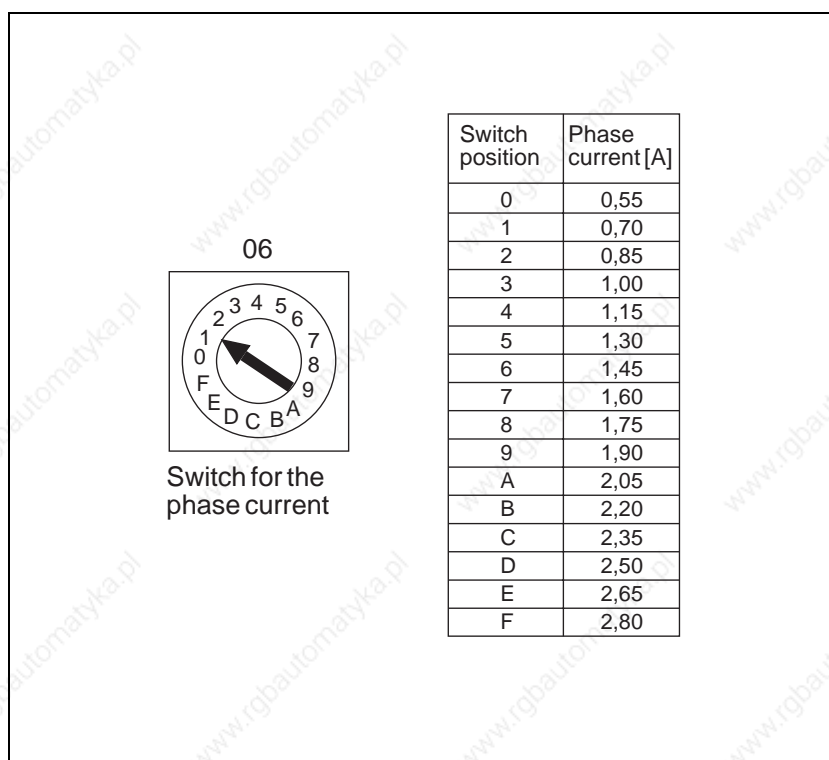

Figure 2-12 Settings of the phase current

# Installation

## Setting of the parameters

Use the DIL switch 05 to set desired parameters as illustrated in Figure 2-13. The basic factory setting is indicated.



### NOTES

- When current reduction is active the motor phase current decreases to 70% in the idling condition (pulse frequency <10 Hz). This leads to cooling of the motor and reduction of the stopping torque to approx. 70%.
- The action of the DIRECT. and F/H-STEP signal inputs can be inverted by means of parameter switch 03 (direction of rotation) and 04 (step size).
- In the case of a half step the motor executes 1000 steps per revolution, in the case of a full step it performs 500 steps per revolution.

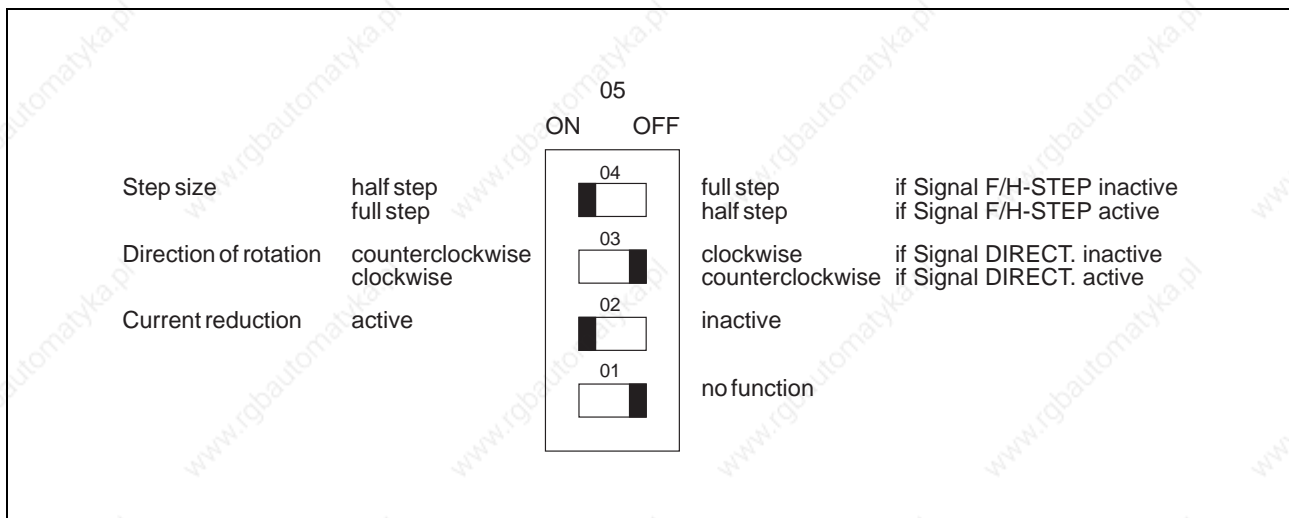

Figure 2-13 Settings of the parameter switch

### 3 Operation

The power drive WS5-9 is operated by means of control signals from the signal interface.

#### 3.1 Signal Description

The meanings and functions of the individual signals are described below.

##### 3.1.1 Input Signals



**NOTE**

An 'active' input means a flow of current from + to -, an 'inactive' input means a flow of current from - to + or no current at all.

**ENABLE (Enabling Command)**

- Input 'active': enabling of power drive. When operation is trouble-free, the standby relay contact of the power drive is at READY.
- Input 'inactive': deletion of a stored fault report (see section 4.2) and resetting of the ring counter. The motor is disconnected from the current. The standby relay contact is at NOT READY.



**CAUTION**

When the ENABLE input is 'inactive', the motor is de-energized, i.e. it has no stopping torque.



**NOTE**

If the error message is repeated, disconnect the mains voltage and rectify the fault using the troubleshooting table (section 4.2).

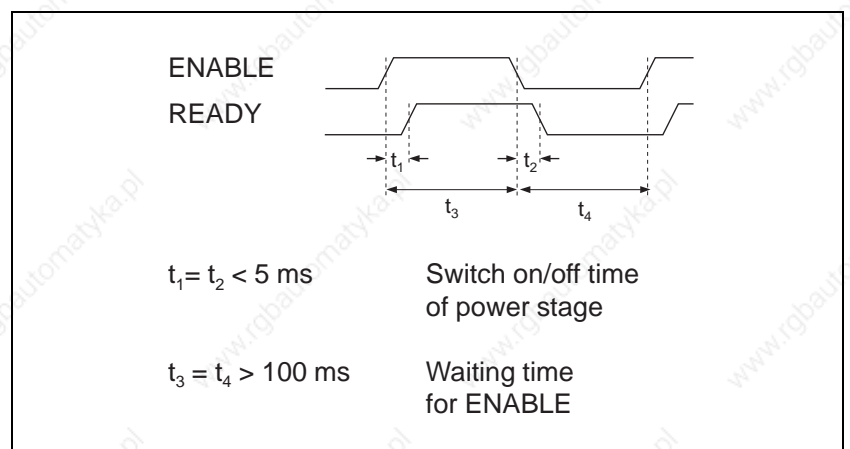

Figure 3-1  
ENABLE/READY  
response times

## PULSE (step)

With each rising signal edge at the PULSE input the motor executes one step.

## DIRECT. (direction of rotation)

Dependent upon the position of the Parameter Switch 05 (see figure 2-13):

- Input 'inactive': clockwise rotation (Parameter Switch OFF)
- Input 'active': counterclockwise rotation (Parameter Switch OFF)

or

- Input 'inactive': counterclockwise rotation (Parameter Switch ON)
- Input 'active': clockwise rotation (Parameter Switch ON)



### NOTE

*Rotation Direction when looking at the motor shaft (flange side).*

For the signal response times for PULSE and DIRECT. See figure 3-2.

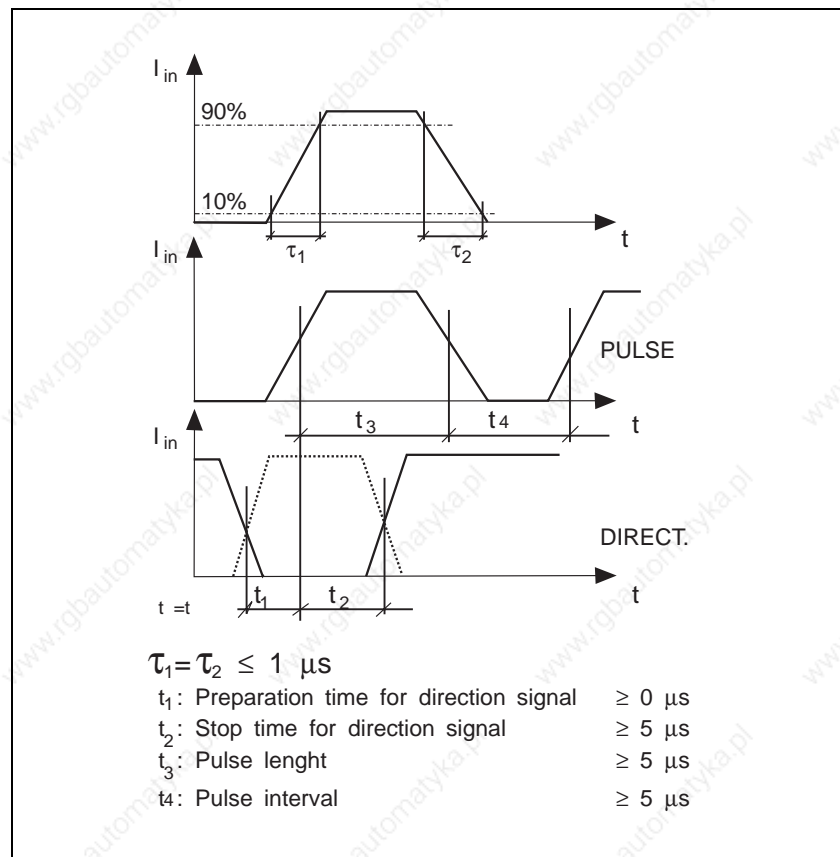

Figure 3-2 PULSE/DIRECT.  
response times

## F/H STEP (stepangle)

Dependent on the adjustment of the parameter switch 05/04 (see figure 2-13):

- Input 'inactive': Half Step (Parameter Switch ON)
- Input 'active': Full Step (Parameter Switch ON)

or

- Input 'inactive': Full Step (Parameter Switch OFF)
- Input 'active': Half Step (Parameter Switch OFF)



### NOTE

*When set on 'Half Step' the motor makes 1000 steps / rotation, on 'Fullstep' it makes 500 steps/ rotation.*

## BOOST (current increase)

- Input 'inactive': Nominal current (as set on Rotary Switch 06)
- Input 'active': Double nominal current (but max. 2.8 A)



### ATTENTION

- ***Current increase via BOOST above the nominal current of the motor is only allowed for short time spans (20% of the switching-on time of the motor, maximum 10 secs).***
- ***The boost function must not be activated for the motors ExRDM 5913/50P and ExRDM 599/50P.***



### NOTE

*If the BOOST is activated during a motor standstill, an active current reduction on parameter switch 05 is blocked.*

### IPWM (current control)

Input for the Pulse Width Modulated signal (PWM) for the Phase Current Control (0-100% or BOOST 0-200% of the set phase current). The PWM signal lies in the frequency range from 6...20 kHz.



#### NOTE

- The Signal Frequency should be selected from outside of the audio range (approx. 20 kHz).
- If the inputs IPWM and BOOST are activated simultaneously, the BOOST function (current increase) is always dominant.

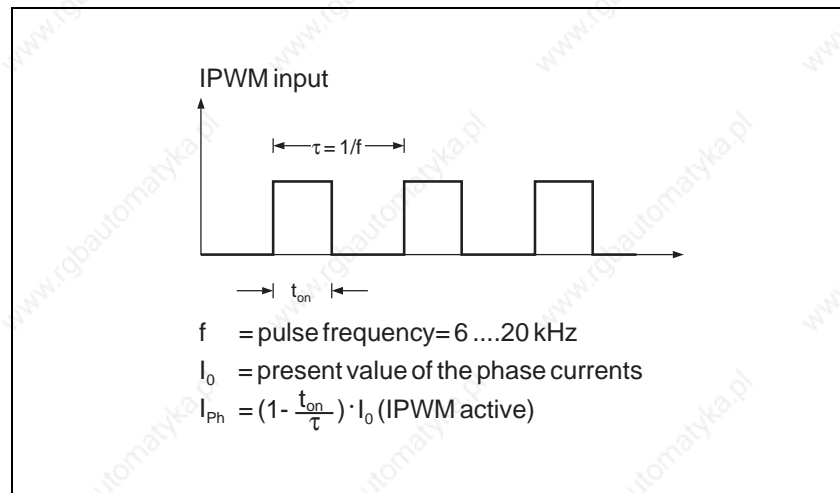

Figure 3-3 Phase current control via input IPWM

## 3.1.2 Output Signals



### NOTE

'Active' output means low-impedance.

'Inactive' output means high-impedance.

### READY (standby)

When the equipment is ready to operate the contacts 32-14 are connected. In the case of an error the contacts 32-13 are connected.



### NOTE

For further information on errors see chapter 4.

### TEMP.INT.

If the permissible operating temperature of the unit is exceeded (approx. 75 °C at the heat sink), the unit is turned off.

Approx. 5 °C before the point of disconnection the TEMP.INT warning device is switched to "inactive" (high impedance).

The superordinate control unit can still respond therefore and can, for example, reduce the motor current or move into the parking position.

## Operation

---

### 3.2 Switching On

Switch on mains voltage at external switch.

After the mains voltage has been switched on, the green LED on the front panel of the equipment lights up and signals that the supply voltage is present at WS5-9. If no red LED lights up on the front panel, the standby relay contact is at READY.

The following precondition must be satisfied:

- ENABLE input active, see Figure 3-1.

### 3.3 Operating Facilities

The equipment is operated by the control signals from the superordinate control unit (see section 3.1); there is no provision for manual operation of WS5-9.



**CAUTION**

***During operation the outside surfaces of the housing which serve as a heatsink may heat up.***

### 3.4 Switching Off

Switch off mains voltage at external switch.



**DANGER**

***Do not loosen the mains cable until after all phases of the supply voltage have been disconnected!***



## 4 Errors / Faults

### 4.1 Status Indicator

Several monitoring and protection functions are used to establish whether the equipment is operating correctly. The status of the equipment is externalised in two ways:

- *visually* by means of 4 LED's on the front panel of the equipment
- *electrically* via the READY outputs. In this way the current status of the power drive is reported to the superordinate control unit (e.g. PLC).

The table indicates the possible statuses of the equipment and the respective consequences for the equipment outputs. The following section contains notes on how to rectify faults quickly.



**CAUTION**

*Depending on the type of fault there will be no current at the motor output. The stopping torque of the motor then falls to zero.*

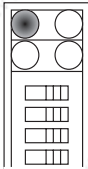
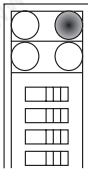
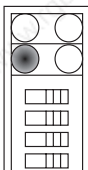
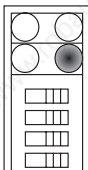
Signalling by LED's	Meaning	Effect, action
 <p>LED 01 (Undervoltage)</p>	<p>The supply voltage is more than 30% below its nominal value (230 V AC)</p>	<p>Power stage is switched off immediately, the undervoltage fault message is not stored. READY inactive (min. 100 ms), motor outputs inactive</p>
 <p>LED 02 (Phase monitoring)</p>	<p>Interruption of one or more motor wires</p> <p>Interruption in a motor coil</p>	<p>Motor has no current. Reset the equipment or turn off supply voltage. READY and the motor outputs inactive</p>
 <p>LED 03 (Short-circuit)</p>	<p>Short-circuit between one or more motor phases or between one or more motor phases and earth</p>	<p>Power stage is switched off immediately. Reset the equipment or turn off supply voltage (at least 1 min.). READY and the motor outputs inactive</p>
 <p>LED 04 (Excessive temperature)</p>	<p>The permissible temperature of the equipment is exceeded.</p>	<p>Power stage is switched off immediately. Reset the equipment or turn off supply voltage (at least 1 min.). READY and the motor outputs inactive</p>

## Errors / Faults

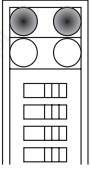
Signalling by LED's	Meaning	Effect, action
 <p>LED 01 und 02 (Reset)</p>	ENABLE is not present	Motor has no current. READY and the motor outputs inactive

The equipment can be reset by deactivating the ENABLE input.

### 4.2 Troubleshooting Table

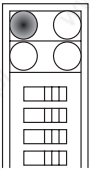
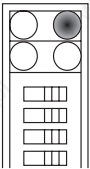
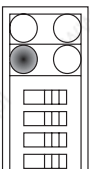
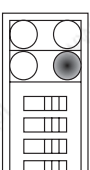
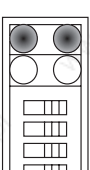
Indicator	Status	Possible cause of fault	Remedy
	Undervoltage	Mains voltage too low Voltage switch in 230 V AC position and equipment is being operated with 115 V AC	Switch off the equipment!  Set the correct voltage on the voltage switch
	Phase interruption	Interruption of one or more wires of the motor cable  Motor faulty	Switch off the equipment! Check motor cable and correct the fault  Replace motor
	Short-circuit	Short-circuit in plug, cable, motor or power stage	Switch off the equipment! Eliminate the short-circuit
	Excessive temperature (power unit)	Poor ventilation of the power unit  Motor current too high	Boost the forced ventilation  Reduce the motor current
	Reset	ENABLE input is inactive	Activate ENABLE input

### 4.3 Storage and Shipping

When equipment or insert cards are stored the following points have to be taken into consideration:

- the maximum humidity (see Technical Data) is not to be exceeded!
- the storage temperature (see Technical data) is not to be exceeded!
- the stored parts have to be protected from dirt and dust!
- equipment and insert cards which show the following symbol are obly to be unpacked, stored or installed in working areas which are electrostatically protected!
- equipment and insert cards which have accumulators should be connected to the mains at least once a month!
- the original packing has to be saved!



When equipment and insert cards are shipped, the following points have to be taken into consideration:

- equipment and insert cards should, if possible, only be shipped in their original packing!
- insert cards should be packed *without* batteries or accumulators into covers which convey electrostatic on both sides (if possible use the original packing)!
- insert cards should be packed with batteries or accumulators into covers which convey electrostatic on the outside and anti-electrostatic on the inside (if possible use the original packing)!
- equipment or insert cards with the following symbol should only be packed in electrostatically protected working areas!



## **Errors / Faults**

---

## **5 Maintenance**

The power drive WS5-9 requires no maintenance.

## Maintenance

---

## 6 Appendix

### 6.1 Equipment Variants

Type Code for Wall Mounted Equipment WS5-9

**WS 5 - 9. x 8 1 - 0 0**

Signal voltage	
0	24 V
1	3,5 ... 5 V

### 6.2 Description of Accessories

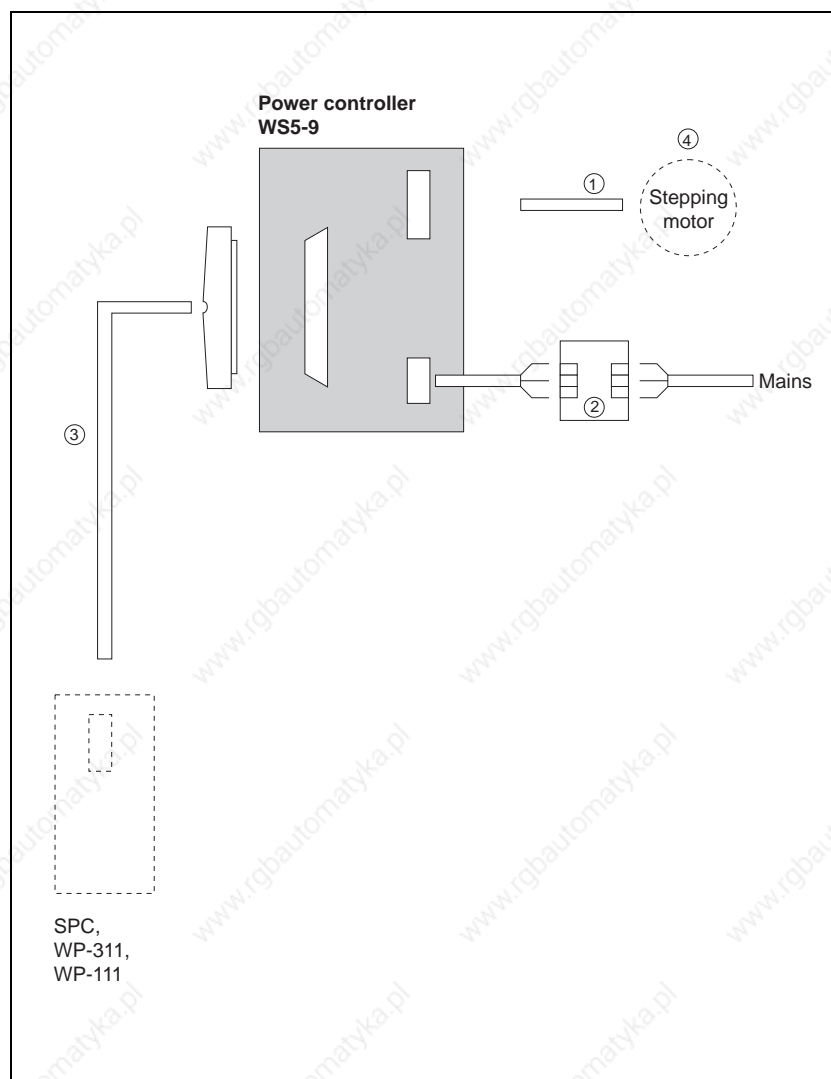

Figure 6-1 Accessories

## Appendix

The following accessories can be supplied by separate order:

Item in Figure 6-1	Description	Order number	Reference
1	Motor cable	62501316xxx	see section 6.2.1
2	Mains filter	62501100200	see section 6.2.2
3	Signal cable (connector at equipment end)	62501401xxx	see section 6.2.3
4	Stepping motor		see catalogue Doc. no. 350

### 6.2.1 Motor Cable

The motor cable can be supplied in the following lengths:

Cable length	Diameter	Order number
5 m	0.75 mm <sup>2</sup>	62501316005
10 m	0.75 mm <sup>2</sup>	62501316010
15 m	0.75 mm <sup>2</sup>	62501316015
20 m	0.75 mm <sup>2</sup>	62501316020
30 m	0.75 mm <sup>2</sup>	62501316030

Special lengths in gradations of 1.0 m are available on request.



**NOTE**  
*Preferred length: 10 m*



**6.2.2 Mains Filter**

A mains filter is inserted in the mains cable for the purpose of radio shielding as per VDE 0871/limit class A.

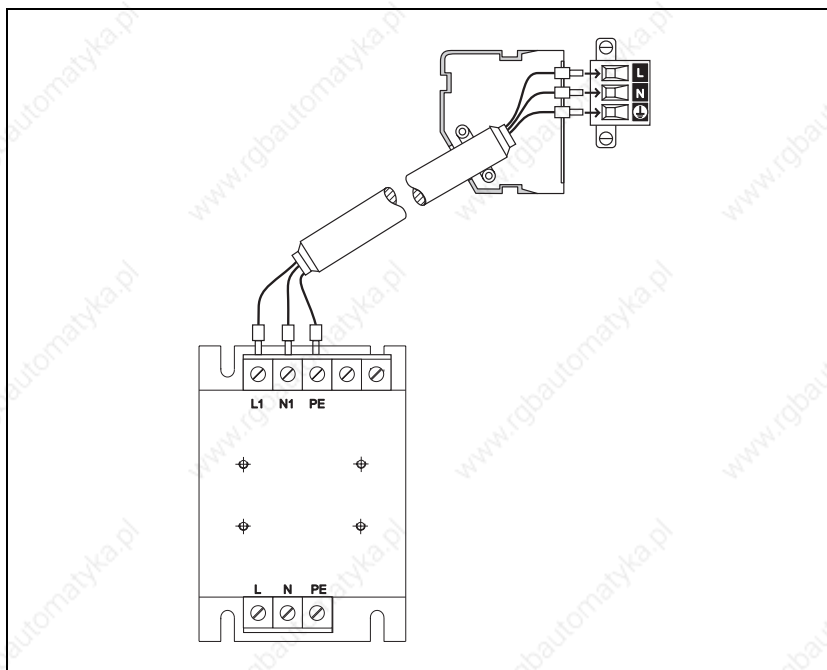

Figure 6-2 Mains filter

Ambient conditions

Storage temperature -25°C to +70°C

Operating temperature 0°C to 55°C

Humidity class, components F acc. to DIN 40 040

Humidity class, tested to IEC 68 part 2-3 at:

Air temperature +40°C, +2°C

Relative humidity 93%, +2%, -3%

non-condensing

**6.2.3 Signal Cable**

The signal cable open at the end of the drive side can be ordered in the following length:

Cable length	Order Number
1 m	62501401010
2 m	62501401020
5 m	62501401050
10 m	62501401100
25 m	62501401250

## Appendix

---

The Signal Cable includes:

<b>Description</b>	<b>Order Number</b>
37 pole socket	N4-673-203
Plug shell (37 pole)	N4-673-239
Cable	H6-928-44

### 6.3 Glossary of Technical Terms

**Boost**

Momentary increase of the set phase current for the purpose of increasing the torque when the motor is accelerating or braking

**Clockwise rotation**

Clockwise rotation of stepping motors. Positive sense of rotation as seen from the motor shaft (flange side)

**Counterclockwise rotation**

Counterclockwise rotation of stepping motors. Negative sense of rotation as seen from the motor shaft (flange side)

**ENABLE**

command Signal input for activation of the controller

**5-phase stepping motor for wall-mounted equipment**

Special stepping motor for wall-mounted equipment from BERGER LAHR

**Full step**

Rotational angle of the 5-phase stepping motor per 0.72° step (corresponds to 500 steps/revolution)

**Half step**

Rotational angle of the 5-phase stepping motor per 0.36° step (corresponds to 1000 steps/revolution)

**Phase current**

The current flowing through a winding of the stepping motor

**Pulse frequency**

Number of driving pulses per second; with each pulse the motor performs one step

**Pulse width modulation PWM**

Control of an analogue quantity (e.g. motor current) via the pulse width/pulse spacing ration of an input signal (see also *current control*)

**Ring counter**

Cyclically operating counter with topped decoding logic for generation of the *current pattern* for the 5 phases of the stepping motor

**Start/Stop frequency**

Largest pulse frequency at which the motor with a given load can start and stop without contouring error

**Step**

Process in which the motor shaft of the stepping motor executes a movement corresponding to one step angle (see also *Half step*, *Full step*)

## Appendix

---

### *Step angle*

Nominal angle through which the motor shaft of the stepping motor for each drive pulse (see also *Half step*, *Full step*)

### *Stop time*

Period within which a signal condition is maintained.

---

## 7 Index

<b>A</b>	
Accessories	6-1
Ambient conditions	1-7
Ambient temperature	1-7
<b>B</b>	
BOOST	2-11, 3-3
<b>C</b>	
Cable route	2-4
Chopper-type power supply	1-3
Circuitry of motor	2-5
Closed-loop circuitry	1-3
Connections	1-1
Control signals	1-3, 3-1
Current increase	3-3, 3-4
Current pattern	1-3
Current reduction	1-3, 2-12
Current selector switch	1-1
<b>D</b>	
Dimensions	1-6
Direction of rotation	1-3
<b>E</b>	
Enabling	3-5
End bracket	2-2
Equipment accessories	6-1
Equipment protection	1-5
Equipment status	4-1
Error message	3-1
Errors	1-3, 4-1
<b>F</b>	
Fasteners/mounting brackets	1-1, 2-2
Fault indication	1-3
Five-point connection	1-2, 2-5
Function connection diagram	1-3
Fuse	1-4
<b>I</b>	
Idling condition	2-12
Input signals	3-1
Inputs	1-4, 3-4
Intermediate circuitry	1-3

## L

LED 1-1, 3-6, 4-1

## M

Mains cable 2-6, 3-6  
Mains connection 1-1, 1-4, 2-6  
Mains filter 6-3  
Mains power unit 1-3, 1-5  
Mains voltage 1-3, 2-3, 2-6, 2-10  
Maintenance 5-1  
Minimum clearance 2-2  
Monitoring functions 4-1  
Motor cable 2-4, 2-10, 6-2  
Motor connection 1-1, 1-4, 2-4  
Motor connection wires 2-5  
Motor stand still 3-3  
Motor types 1-2  
Motor voltage 1-4

## O

Output signals 3-5  
Outputs 1-5  
Overloading 2-11

## P

Parameter switch 1-1, 1-3, 2-3, 2-12, 3-2  
Phase current 1-4, 2-5, 2-11  
Power dissipation 1-4, 1-7, 2-2, 2-11  
Protection circuits 1-5  
Protection function 4-1  
Push-pull drive 2-7, 2-9  
PWM signal 3-4

## Q

Qualified electrical engineers 2-3

## R

Ring counter 1-3

## S

Setting elements 2-10  
Settings 2-11  
Signal cable 2-7, 2-10, 6-3  
Signal connection 1-1, 1-4, 2-7  
Signal connector 2-7  
Signal interface 2-8  
Signal inputs 2-8, 2-12  
Signal output 2-8

Step	3-2
Step angle	1-3
Stepping motor	1-2
5-phase stepping motor	1-2
Switch cabinet	1-1, 1-7, 2-2

**T**

Technical data	1-4
Technical terms	6-4
Trouble shooting table	4-2
Type code	6-1

**V**

Voltage switch	1-1, 2-6
----------------	----------

**W**

Weight	1-6
--------	-----

# Index

---