

SIEMENS

SIMOREG DC-MASTER Converter Commutation Protector

Operating Instructions

(SIMOREG CCP)

6RA70 Series



Device software version:

At the time of printing these operating instructions, the SIMOREG CCP was delivered with software version **1.2**.

The SIMOREG DC-MASTER 6RA70 basic unit must have software version 2.2 or higher.

The software version of the SIMOREG DC-MASTER 6RA70 and the SIMOREG CCP can be fetched at the r060 and r065 parameters, and at the n560 parameter, respectively.

The latest software version for the SIMOREG CCP is available at the following Internet page

<http://support.automation.siemens.com/WW/view/en/19847387/133100>

The reproduction, transmission or use of this document or contents is not permitted without express written authority. Offenders will be liable for damages. All rights, including rights created by patent grant or registration of a utility model or design, are reserved.

We have checked that the contents of this publication agree with the hardware and software described herein. Nonetheless, differences might exist and therefore we cannot guarantee that they are completely identical. The information given in this publication is reviewed at regular intervals and any corrections that might be necessary are made in the subsequent printings. Suggestions for improvement are welcome at all times.

SIMOREG ® is a registered trademark of Siemens

0 Contents**ENGLISH**

	Page
0 Contents	3
1 Safety information	4
2 Type spectrum	9
2.1 Converter order numbers	9
2.2 Ordering information for options	9
2.3 Selection of a suitable SIMOREG CCP	10
2.3.1 Selection table for 4Q basic units	10
2.3.2 Selection table for 1Q basic units	11
2.4 Rating plate	12
2.5 Packaging label	12
3 Description	13
3.1 Field of application	13
3.2 Working principle	13
3.3 Technical data	14
3.4 Overview diagram	15
3.5 Applicable standards	17
3.6 Certification	17
3.7 Abbreviations	17
4 Shipment, unpacking	18
5 Installation	19
5.1 Dimension diagrams	20
6 Connections	22
6.1 Recommended connection	24
6.1.1 Variants for the interconnection of the K1 main contactor (circuit-breaker)	25
6.1.2 Suggestion for connection if a Siemens 3WL circuit breaker is used	25
6.2 Connection of devices in parallel	27
6.3 Fuses	28
6.4 Location of the terminals, connectors and fuses	28
6.5 Terminal assignment, connectors	29
7 Start-Up	32
7.1 General safety information for start-up	32
7.2 Operation by means of the SIMOREG device	33
7.2.1 Parameters	33
7.2.2 Connectors	39
7.2.3 Faults	40
7.2.4 Alarms	42
7.3 Commissioning steps	43
8 Maintenance	45
8.1 Procedure for updating software	46
8.2 Replacement of components	47
8.2.1 Replacement of PCBs	47
8.2.2 Replacement of diodes, thyristor and IGBT modules	48
9 Servicing	50
9.1 Technical Support	50
9.2 Repairs	50
9.3 On-site servicing	50
9.4 Spare parts	51
10 Environmental compatibility	52
11 Appendix	53

1 Safety information



WARNING



Hazardous voltages are present in this electrical equipment during operation. Non-observance of the safety instructions can result in death, severe personal injury or substantial property damage.

Only qualified personnel should work on or around the equipment after first becoming thoroughly familiar with all warning and safety notices and maintenance procedures contained herein. The successful and safe operation of this equipment is dependent on proper handling, installation, operation and maintenance.

Definitions:

- **QUALIFIED PERSONNEL**

For the purpose of this Instruction Manual and product labels, a "Qualified person" is someone who is familiar with the installation, construction and operation of the equipment and the hazards involved. He or she must have the following qualifications:

1. Trained and authorized to energize, de-energize, clear, ground and tag circuits and equipment in accordance with established safety procedures.
2. Trained in the proper care and use of protective equipment in accordance with established safety procedures.
3. Trained in rendering first aid.

- **⚠ DANGER**

indicates an imminently hazardous situation which, if not avoided, will result in death or serious injury.

- **⚠ WARNING**

indicates a potentially hazardous situation which, if not avoided, could result in death or serious injury.

- **⚠ CAUTION**

used with the safety alert symbol indicates a potentially hazardous situation which, if not avoided, may result in minor or moderate injury.

- **CAUTION**

used without the safety alert symbol indicates a potentially hazardous situation which, if not avoided, may result in property damage.

- **NOTICE**

NOTICE used without the safety alert symbol indicates a potentially situation which, if not avoided, may result in an undesirable result or state.

NOTE

These operating instructions do not purport to cover all details or variations in equipment, nor to provide for every possible contingency to be met in connection with installation, operation or maintenance.

Should further information be desired or should particular problems arise which are not covered sufficiently for the purchaser's purposes, the matter should be referred to the local Siemens Sales Office.

The contents of these operating instructions shall not become part or modify any prior or existing agreement, commitment or relationship. The Sales Contract contains the entire obligations of Siemens. The warranty contained in the contract between the parties is the sole warranty of Siemens. Any statements contained herein do not create new warranties or modify the existing warranty.

**DANGER**

Converters contain hazardous electrical voltages, Death, severe bodily injury or significant material damage can occur if the safety measures are not followed.

1. Only qualified personnel, who are knowledgeable about the converters and the provided information, can install, start up, operate, troubleshoot or repair the converters.
2. The converters must be installed in accordance with all relevant safety regulations (e.g. DIN VDE) as well as all other national or local regulations. Operational safety and reliability must be ensured by correct grounding, cable dimensioning and appropriate short-circuit protection.
3. All panels and doors must be kept closed during normal operation.
4. Before carrying out visual checks and maintenance work, ensure that the AC power supply is disconnected and locked out. Before the AC supply is disconnected, both converters and motors have hazardous voltage levels. Even when the converter contactor is open, hazardous voltages are still present.
5. When making measurements with the power supply switched on, electrical connections must not be touched under any circumstances. Remove all jewelry from wrists and fingers. Ensure that the test equipment is in good conditions and operationally safe.
6. When working on units which are switched on, stand on an insulating surface, i.e. ensure that you are not grounded.
7. Carefully follow the relevant instructions and observe all danger, warning and cautionary instructions.
8. This does not represent a full listing of all the measures necessary for safe operation of the equipment. If you require other information or if certain problems occur which are not handled in enough detail in the information provided in the Instruction Manual, please contact your local Siemens office.





CAUTION
Electrostatically sensitive devices

The converter contains electrostatically sensitive devices. These can easily be destroyed if they are not handled correctly. If, however, it is absolutely essential for you to work on electronic modules, please pay careful attention to the following instructions:

- Electronic modules (PCBs) should not be touched unless work has to be carried out on them.
- Before touching a PCB, the person carrying out the work must himself be electrostatically discharged. The simplest way of doing this is to touch an electrically conductive earthed object, e.g. socket outlet earth contact.
- PCBs must not be allowed to come into contact with electrically insulating materials – plastic foil, insulating table tops or clothing made of synthetic fibers –
- PCBs may only be set down or stored on electrically conducting surfaces.
- When carrying out soldering jobs on PCBs, make sure that the soldering tip has been earthed.
- PCBs and electronic components should generally be packed in electrically conducting containers (such as metallized-plastic boxes or metal cans) before being stored or shipped.
- If the use of non-conducting packing containers cannot be avoided, PCBs must be wrapped in a conducting material before being put in them. Examples of such materials include electrically conducting foam rubber or household aluminium foil.

For easy reference, the protective measures necessary when dealing with sensitive electronic components are illustrated in the sketches below.

- | | | | |
|-----|----------------------|-----|----------------------------------|
| a = | Conductive flooring | d = | Anti-static overall |
| b = | Anti-static table | e = | Anti-static chain |
| c = | Anti-static footwear | f = | Earthing connections of cabinets |

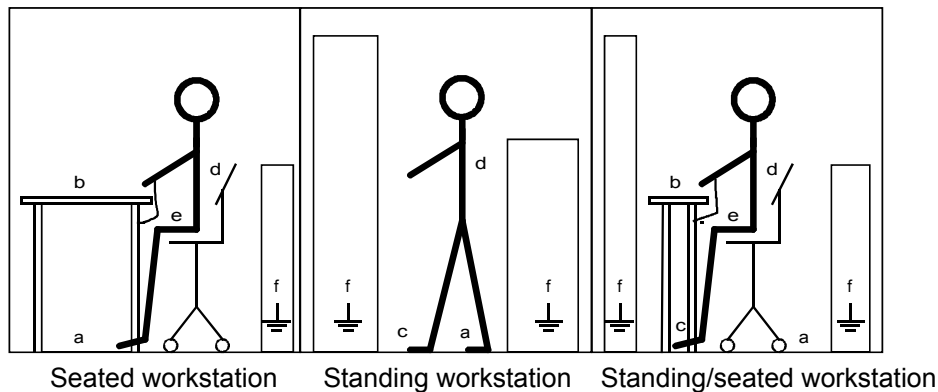

WARNING

Hazardous voltages are present in this electrical equipment during operation. Non-observance of the safety instructions can result in death, severe personal injury or substantial property damage.

Only qualified personnel should work on or around the equipment after first becoming thoroughly familiar with all warning and safety notices and maintenance procedures contained herein.

The successful and safe operation of this equipment is dependent on proper handling, installation, operation and maintenance.



Safety at Work (for information purposes only)

Extract from the safety regulations for electrical professions, published on the Internet website of IG Metall Hamburg (Stand 06/2004):

<http://www2.igmetall.de/homepages/hamburg/arbeitsicherheit-startseite/sicherheitsregeln-elektro.html>

The five safety regulations for electrical professions

Before any work is started, the place of work must be clearly identified and, if necessary, marked out.

- Safety isolation
- Secure to prevent accidental reconnection
- Make sure the installation / equipment is not carrying voltage
- Ground and short-circuit
- Cover or fence off any adjacent live parts.

In general, the five safety regulations are to be followed in the order in which they are listed. Due to the type of construction of an electrical installation, however, a different sequence may be necessary, for example in the case of remote-controlled or locked installations. However, the order in which the five safety regulations are followed must always be such that no hazards can occur (...)

Safety isolation

Isolation from the power supply means switching off or disconnecting an installation, part of an installation or an item of equipment from all ungrounded conductors.

If the person in charge or a person working alone does not isolate the equipment from the supply himself/herself, he or she must wait until isolation from the supply has been confirmed orally, by telephone or by other means of long distance communication. In order to avoid transmission errors, the recipient must return the message to the sender and ask for confirmation of its correctness. In all cases, the name, office or company of the persons engaged in such communication must be indicated, after which they must be repeated by the communication partner for confirmation. Long messages must be written down immediately.

The fact that voltage is not present does not constitute a confirmation of isolation from the supply.

It is not permissible to agree on a time after which the equipment can be regarded as isolated from the supply.

Only use a fuse handle with a sleeve cover when inserting and removing low-voltage high-breaking-capacity fuse links and, when doing so, always use a face shield. When handling high-voltage high-breaking-capacity fuse links, use appropriate fuse tongs; otherwise, isolation from the power supply must first be carried out and ensured.

Capacitors without an automatic discharging device must be discharged with suitable devices after isolation from the supply. (...)

Secure to prevent accidental reconnection

Serious accidents can happen due to inadvertent reconnection because the equipment / installation on which work is being done suddenly becomes live.

All disconnecting and operating devices such as switches, separators, controllers, buttons, fuses or circuit-breakers which were used to isolate the equipment / installation from the supply are to be secured against reconnection (e.g. by means of a padlock). A warning sign forbidding any switching operations must be displayed immediately.

Such warning signs are to be fixed in place so that they cannot fall down. They must never be attached to active parts. If there is a danger that the sign will come into contact with live parts of the equipment/installation, the sign and connections for hanging up the sign must be made of insulating material.

Circuit-breakers or fuse links which have been removed in order to disconnect cables or leads must be kept in a safe place. It is recommended that blockstops or low-voltage high-breaking-capacity dummy elements which are insulated and can only be removed with a special socket wrench are screwed in or inserted in place of the removed fuse links or circuit-breakers.

Whenever possible, switches or switch operating mechanisms are to be locked in position or locked away.

If the switches have a powered mechanism (powered by compressed air, electricity, spring etc.), any devices that exist for interrupting application of the force are to be used (e.g. to cut off compressed air supply, to bleed the pipes, to uncouple or interrupt the flow of control current etc.).

Remotely controlled switches in closed electrical facilities can also be secured against reconnection by the following measures:

- In the case of computer-aided switching operations, the software is designed in such a way that inadvertent reconnection is prevented reliably.
- The signal indicating the position of the switch must be reliably transmitted to the remote control station via a fail-safe transmission path.
- In the remote control station, a warning sign with the message "Do not operate switch!" or some other device warning of the danger if the control switch in question is operated must be displayed.
- In the remotely controlled installation, an instruction must be displayed in a clearly visible place with the following words: "Switching operations relating to this installation / equipment are forbidden unless the xxx (remote control station to be named) issues express instructions to carry out such operations or agrees to them.
- An operating instruction must inform the personnel responsible of this restricted authority to perform switching operations.

Make sure the installation / equipment is not carrying voltage

A study of electrical accidents has shown that a large number of accidents are caused due to the failure to observe the 3rd rule. What is shocking is that the number of accidents is rising, even in the low-voltage range.

Even if you are sure that the voltage supply is not connected, it is absolutely necessary to make sure that the installation / equipment is not carrying voltage.

The fact that the installation/equipment may be carrying voltage due to stand-by power supply systems, inverse transformation or an auxiliary supply system is often forgotten.

Only a qualified electrician or a person instructed in the relevant areas of electrical engineering is permitted to determine whether the installation/equipment is carrying voltage or not and must use suitable devices or instruments for this purpose.

The use of universal measuring instruments is forbidden due to the high risk of accidents in installations with high energy flows.

For verification of safe isolation from supply, all poles must always be switched, i.e. at each individual conductor.

Before using a voltage detector, make sure it is in perfect working order.

Ground and short-circuit

The purpose of grounding and short-circuiting parts of the installation / equipment on which work is to be done is to provide direct protection for all employees against the dangers of electricity.

The device used for grounding and short-circuiting must first be connected with the grounding system or a ground electrode and only then connected to the part of the installation/equipment to be grounded unless grounding and short-circuiting are carried out at the same time, e.g. with a grounding switch.

The workplace must be safeguarded in such a way that protection is provided in the event of inadvertent reconnection and against interference voltage (e.g. electric influence, induction or residual voltage).

All the devices and instruments for grounding and short-circuiting must be designed so that they guarantee reliable contact with the grounding system and with the parts of the installation/equipment to be grounded. They must also withstand the short-circuit current until they are switched off (see following overview). It is only permissible to use steel frames and masts as the grounding and short-circuiting connection if they satisfy the conditions named above.

Grounding and short-circuiting must be visible from the place where employees are working. Otherwise, an additional grounding indicator, display device or clear marking is necessary at the place of work (....)

When work is being done on transformers, grounding and short-circuiting must be carried out at the high-voltage and low-voltage ends, even when the voltage at the low-voltage end is lower than 1000V.

If work is being done on transformers with flanged-on sealing ends, the switching points which belong to the high-voltage and low-voltage ends and are nearest to the transformer must be grounded and short-circuited.

While the measurements are being carried out, it is permissible to cancel grounding and short-circuiting if necessary. It is permissible to connect measuring cables to the active parts only after the part of the installation/equipment in question has been grounded and short-circuited.

Other additional stipulations are applicable besides these general regulations.

Installations / equipment with rated voltage of up to 1000V.

These installations / types of equipment, except overhead lines, do not normally need to be grounded and short-circuited but grounding and short-circuiting do, of course, ensure a higher level of safety.

However, if there is a risk that voltage can be applied to the installation / equipment that has been isolated from the power supply, e.g. by a stand-by power supply system, grounding and short-circuiting are obligatory. (....)

Cover or fence off any adjacent live parts

Working near live parts must be avoided wherever possible. A check must always be made to find out whether the installation / equipment can be reliably isolated from the supply.

If this is not possible, the active parts must be protected by covering or fencing off the live parts for the duration of the work. It is especially important to take into account the voltage, operating location, type of work and the tools and equipment used.

Covers must have adequate insulating qualities and must be able to cope with all the types of mechanical stress to be expected. (....) Insulation panels or protective grilles, for example, are recommended. If there is a danger of persons coming into contact with live parts of the installation / equipment or if the danger zone is approached or entered, the material must have sufficient electric strength. After work has been completed, it must be determined whether the electric strength has suffered due to mechanical or electrical damage.

Always make sure that all live parts that endanger personnel directly or indirectly (e.g. due to tools, workpieces, conductor bars, iron bars, ladders, scaffolding) are covered if the installation/equipment cannot be isolated safely from the supply. If a cover cannot be used, any adjacent live parts are also to be isolated from the supply.

It is also important to mark the hazard areas sufficiently and clearly. Flags, demarcation ropes, or ropes with fluttering attachments have proven to be highly suitable for this purpose. The place of work must be marked out clearly.

Any locked, live switchgear panels next to the place of work must be clearly marked, e.g. by panels fastened to doors or by chains.

In open indoor switching installations without partition walls, the switchgear panels where work is done are to be separated from neighboring cells by movable walls or grilles.

In outdoor installations as well, all the working areas must be marked clearly. Chains and warning signs made of weather-proof plastic are very suitable for this.

Release procedure

Only after compliance with the five safety regulations is the person responsible permitted to release the place of work so that the work can be carried out because, otherwise, safe and reliable protection against electrical accidents could not be guaranteed!

Although the release procedure is not required in writing in the set of rules, we urgently recommend that a record be made of the procedure (....)

2 Type spectrum

2.1 Converter order numbers

Device	Rated current	Rated voltage	Live area that can be covered	Order No. (MLFB)
SIMOREG CCP 600A/460V	600 A	460 V	up to 600 A	6RA7085-6FC00-0
SIMOREG CCP 1200A/460V	1200 A	460 V	up to 1200 A	6RA7091-6FC00-0
SIMOREG CCP 1000A/690V	1000 A	690 V	up to 1000 A	6RA7090-6KC00-0
SIMOREG CCP 2000A/460V	2000 A	460 V	up to 2000 A	6RA7095-6FC00-0
SIMOREG CCP 2000A/690V	2000 A	690 V	up to 2000 A	6RA7095-6KC00-0

2.2 Ordering information for options

Option	Codes	Order No. (MLFB)
Operating instructions in printed form for Converter Commutation Protector SIMOREG CCP in German / English	D74	6RX1700-0DD74
Operating instructions in printed form for Converter Commutation Protector SIMOREG CCP in French / Italian / Spanish	D83	6RX1700-0DD83
Operating instructions for SIMOREG DC-MASTER 6RA70 and SIMOREG CCP and Drive Monitor in German / English / French / Italian / Spanish on CD-ROM		CD 1: 6RX1700-0AD64 CD 2 (DriveMonitor): 6RX1700-1AD64
UTP CAT5 patch cable in accordance with ANSI/EIA/TIA 568 Parallel switch cable for SIMOREG 6RA70 and SIMOREG CCP approx. 5m Connecting cable for the extinction-pulse interface for connecting SIMOREG CCPs in parallel and connecting cable for the group firing-pulse interface to the SIMOREG (CUD2)		6RY1707-0AA08

Ordering of options using codes

- - -
 +

SIMOREG CCP order no. with suffix Z and codes (several codes together) and/or plaintext (if required)

2.3 Selection of a suitable SIMOREG CCP

The basis for the selection table is not only the device rated data (considering the associated limit values) for the SIMOREG DC-MASTER and SIMOREG CCP components, but also typical rated data for SIEMENS direct-current motors from the DA12 / 2004 product catalog.

2.3.1 Selection table for 4Q basic units

SIMOREG DC-MASTER 6RA70		Converter Commutation Protector SIMOREG CCP 6RA70...				
Order No.	Rated DC voltage / DC current	..85-6FC00-0 460V / up to 600A	..91-6FC00-0 460V / up to 1200A	..90-6KC00-0 690V / up to 1000A	..95-6FC00-0 460V / up to 2000A	..95-6KC00-0 690V / up to 2000A
6RA7013-6DV62-0	420V / 15A					
6RA7018-6DV62-0	420V / 30A					
6RA7025-6DV62-0	420V / 60A					
6RA7028-6DV62-0	420V / 90A					
6RA7031-6DV62-0	420V / 125A					
6RA7075-6DV62-0	420V / 210A					
6RA7078-6DV62-0	420V / 280A	x				
6RA7081-6DV62-0	420V / 400A	x				
6RA7085-6DV62-0	420V / 600A	x	x			
6RA7087-6DV62-0	420V / 850A		x			
6RA7091-6DV62-0	420V / 1200A		x		x	
6RA7093-4DV62-0	420V / 1600A				x	
6RA7095-4DV62-0	420V / 2000A				x	
6RA7098-4DV62-0	420V / 3000A					
6RA7018-6FV62-0	480V / 30A					
6RA7025-6FV62-0	480V / 60A					
6RA7028-6FV62-0	480V / 90A					
6RA7031-6FV62-0	480V / 125A					
6RA7075-6FV62-0	480V / 210A					
6RA7078-6FV62-0	480V / 280A	x				
6RA7082-6FV62-0	480V / 450A	x				
6RA7085-6FV62-0	480V / 600A	x	x			
6RA7087-6FV62-0	480V / 850A		x			
6RA7091-6FV62-0	480V / 1200A		x			
6RA7025-6GV62-0	600V / 60A					
6RA7031-6GV62-0	600V / 125A					
6RA7075-6GV62-0	600V / 210A					
6RA7081-6GV62-0	600V / 400A			x		
6RA7085-6GV62-0	600V / 600A			x		
6RA7087-6GV62-0	600V / 850A			x		
6RA7090-6GV62-0	600V / 1100A					x
6RA7093-4GV62-0	600V / 1600A					x
6RA7095-4GV62-0	600V / 2000A					x
6RA7096-4GV62-0	600V / 2200A					
6RA7097-4GV62-0	600V / 2800A					
6RA7086-6KV62-0	725V / 760A			x		
6RA7090-6KV62-0	725V / 1000A			x		x
6RA7093-4KV62-0	725V / 1500A					x
6RA7095-4KV62-0	725V / 2000A					x
6RA7097-4KV62-0	725V / 2600A					
6RA7088-6LV62-0	875V / 950A					
6RA7093-4LV62-0	875V / 1500A					
6RA7095-4LV62-0	875V / 1900A					
6RA7096-4MV62-0	1000V / 2200A					

= Suitable

= Not suitable (see note)

Note:

For plant configurations with reduced rated values (e.g. DC Rating, US Rating, voltage derating), in some circumstances suitable device combinations can be found that are not listed in the above table.

2.3.2 Selection table for 1Q basic units

SIMOREG DC-MASTER 6RA70		Converter Commutation Protector SIMOREG CCP 6RA70...				
Order No.	Rated DC voltage / DC current	..85-6FC00-0 460V / up to 600A	..91-6FC00-0 460V / up to 1200A	..90-6KC00-0 690V / up to 1000A	..95-6FC00-0 460V / up to 2000A	..95-6KC00-0 690V / up to 2000A
6RA7018-6DS22-0	485V / 30A					
6RA7025-6DS22-0	485V / 60A					
6RA7028-6DS22-0	485V / 90A					
6RA7031-6DS22-0	485V / 125A					
6RA7075-6DS22-0	485V / 210A					
6RA7078-6DS22-0	485V / 280A	x				
6RA7081-6DS22-0	485V / 400A	x				
6RA7085-6DS22-0	485V / 600A	x	x			
6RA7087-6DS22-0	485V / 850A		x			
6RA7091-6DS22-0	485V / 1200A		x		x	
6RA7093-4DS22-0	485V / 1600A				x	
6RA7095-4DS22-0	485V / 2000A				x	
6RA7098-4DS22-0	485V / 3000A					
6RA7018-6FS22-0	550V / 30A					
6RA7025-6FS22-0	550V / 60A					
6RA7028-6FS22-0	550V / 90A					
6RA7031-6FS22-0	550V / 125A					
6RA7075-6FS22-0	550V / 210A					
6RA7078-6FS22-0	550V / 280A	x				
6RA7082-6FS22-0	550V / 450A	x				
6RA7085-6FS22-0	550V / 600A	x	x			
6RA7087-6FS22-0	550V / 850A		x			
6RA7091-6FS22-0	550V / 1200A		x			
6RA7025-6GS22-0	690V / 60A					
6RA7031-6GS22-0	690V / 125A					
6RA7075-6GS22-0	690V / 210A					
6RA7081-6GS22-0	690V / 400A			x		
6RA7085-6GS22-0	690V / 600A			x		
6RA7087-6GS22-0	690V / 850A			x		
6RA7090-6GS22-0	690V / 1100A					x
6RA7093-4GS22-0	690V / 1600A					x
6RA7095-4GS22-0	690V / 2000A					x
6RA7095-4GS22-5	690V / 2000A					x
6RA7096-4GS22-0	690V / 2200A					
6RA7096-4GS22-5	690V / 2200A					
6RA7097-4GS22-0	690V / 2800A					
6RA7086-6KS22-0	830V / 720A			x		
6RA7088-6KS22-0	830V / 950A			x		x
6RA7093-4KS22-0	830V / 1500A					x
6RA7095-4KS22-0	830V / 2000A					x
6RA7095-4KS22-5	830V / 2000A					x
6RA7097-4KS22-0	830V / 2600A					
6RA7088-6LS22-0	1000V / 900A					
6RA7093-4LS22-0	1000V / 1500A					
6RA7095-4LS22-0	1000V / 1900A					
6RA7095-4LS22-5	1000V / 1900A					
6RA7096-4MS22-0	1140V / 2200A					

x



= Suitable

= Not suitable (see note)

Note:

For plant configurations with reduced rated values (e.g. DC Rating, US Rating, voltage derating), in some circumstances suitable device combinations can be found that are not listed in the above table.

2.4 Rating plate





SIMOREG DC-MASTER	
Converter Commutation Protector	
SIEMENS	
	
Bestellnr./Order No	1P 6RA70 ... - 6 ... - 0
	
Fabrik-Nr./Serial No	S Q6
Nennstrom/Rated Current	... A
Nennspannung/Rated Voltage	... V
Netzfrequenz/Frequency	50 / 60 Hz
Erz.-Stand/Prod State	A1
Kühlung/Cooling	S
	
MADE IN EU (AUSTRIA)	

... Bar code for order number (MLFB)
 ... A -Z is affixed after the MLFB for options
 ... Code for options (order-specific)
 ... Bar code, serial number (order-specific)

... Space for other symbol e.g.:



2.5 Packaging label

SIMOREG DC-MASTER	SIEMENS
Converter Commutation Protector	
6RA70 ... - 6 ... - 0	
	
1P 6RA70 ... - 6 ... - 0	QTY 1
	
S Q6	
	
Q	SW-STAND (Version) 1.0
	E-STAND (Version) A1
MADE IN EU (AUSTRIA)	

... Space for other symbol
 ... A -Z is affixed to the MLFB for options, followed by the code for the relevant option (order-specific)

3 Description

3.1 Field of application

The SIMOREG DC-MASTER Converter Commutation Protector (SIMOREG CCP) is for protecting the semiconductor fuses of a line-commutated power converter in inverter mode. If the inverter stalls, a large current is created in the regenerating direction via the power system or a crossover current is created in the power converter. The SIMOREG CCP limits this current to a harmless level so that thyristors and the associated super-fast fuses are protected. As a result, time-consuming and expensive replacement of the fuses is no longer necessary. Stalling of the inverter cannot be prevented but its effects can.

Compatibility:

Because the sensor technology and the recognition of a commutation failure can only be made in the SIMOREG basic unit the SIMOREG CCP is only compatible to line-commutated converters of the SIMOREG DC-MASTER 6RA70 series (software version 2.2 and later).

Use with converters connected in parallel is possible.

3.2 Working principle

The line voltage, the line current, and the armature voltage are recorded in the basic unit. These quantities are used to determine whether a commutation failure has occurred (inverter shoot-through).

If this is the case, the following happens:

1. The firing pulses in the SIMOREG DC-MASTER are blocked immediately.
2. The SIMOREG DC-MASTER transmits (via serial interface) an "extinguish command" to the SIMOREG CCP
3. The SIMOREG CCP extinguishes the thyristors by connecting precharged extinguishing capacitors anti-parallel to all thyristors. Consequently, the current commutates from the converter into the SIMOREG CCP. The surge absorbing capacitors will initially be discharged by the accepted current and then charged reversed. Once the voltage of the surge absorbing capacitors has reached the value of the motor EMF, the armature current begins to extinguish itself. The armature voltage, however, continues to increase. As soon as it has attained the limiting value, resistors will be added that accept the energy fed back from the motor during the remaining time of the current reduction.
4. Fault indication F030 is triggered in the SIMOREG DC-MASTER.
5. The SIMOREG CCP discharges the commutation capacitors again so that a new extinguishing process is possible.

Each time the line voltage is switched on (e.g. by means of a line contactor), the SIMOREG CCP needs approx. 3 secs until it is ready for use again because the commutation capacitors first have to be charged.

After an extinguishing process, the SIMOREG CCP requires some time before it becomes operational again. This duration depends on the actions during the extinguishing process and immediately afterwards. Firstly, the surge absorbing capacitors in the SIMOREG CCP must be recharged to the required value (approximately 10 seconds). Secondly, the chopper resistors that during the armature current reduction convert the energy to heat need a cooling time calculated by a software algorithm. Depending on the energy to be extinguished, this time can be as long as approximately 20 minutes.

3.3 Technical data

Order No.	6RA70...	..85-6FC00-0	..91-6FC00-0	..90-6KC00-0	..95-6FC00-0	..95-6KC00-0
Rated voltage	V	460 (+15% / -20%)	460 (+15% / -20%)	690 (+10% / -20%)	460 (+15% / -20%)	690 (+10% / -20%)
Rated current	A	600	1200	1000	2000	2000
Live area that can be covered	A	up to 600	up to 1200	up to 1000	up to 2000	up to 2000
Rated supply voltage electronics power supply	V	2AC 380 (– 20%) to 460 (+15%); I _n =1A or 1AC 190 (– 20%) to 230 (+15%); I _n =2A				
Rated frequency	Hz	45 to 65				
Power loss	W	100	100	100	100	100
Operational ambient temperature	°C	0 to 55				
Storage and transport temperature	°C	– 25 to +70				
Installation altitude above sea level		≤ 1000 m				
Environmental class DIN IEC 60 721-3-3		3K3				
Degree of pollution EN50178		2 *)				
Degree of protection DIN EN 60529		IP00				
Dimensions (HxWxD)	mm	780 x 406 x 500				
Dimension diagram see Section		0	0	0	0	0
Weight (approx.)	kg	35	35	45	55	75

Derating as a function of installation altitude:

Units can operate at altitudes of up to 4500m when the electronics is supplied with voltages of 460 VAC line-to-line (maximum 300 VAC to earth). The maximum permissible voltage up to 5000m is 400 VAC line-to-line (maximum 230 VAC to earth).

At higher altitudes, or at higher voltages, only basic insulation is afforded rather than "Protection by electrical separation".

*) Definition of degree of pollution 2:

Under normal conditions, only non-conductive pollution occurs. Occasionally, pollution may become conductive for a short period of time when the electronic equipment is not in operation.

3.4 Overview diagram

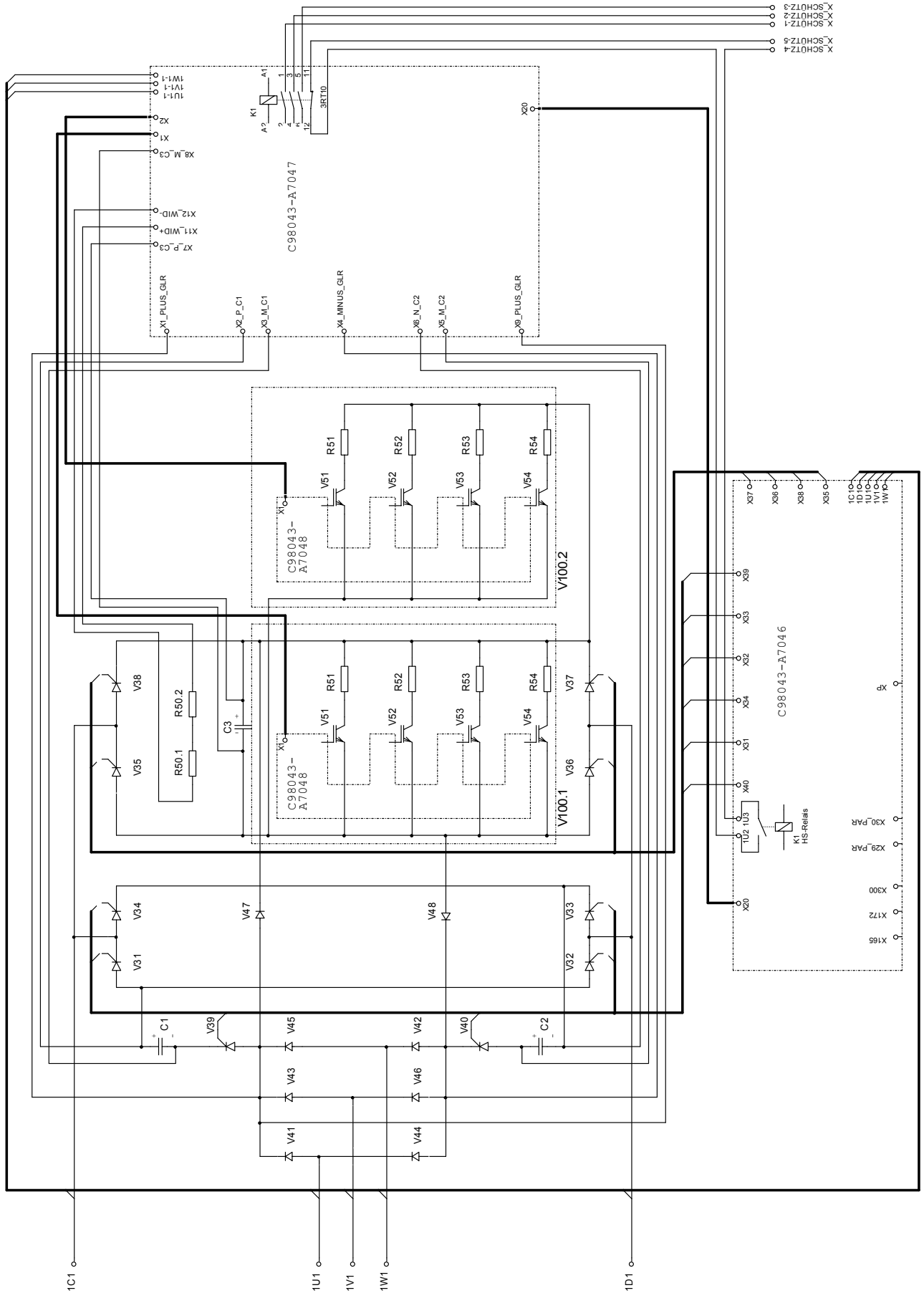

Arrangement of the thyristor- und diode- modules

Devices 6RA70...85-6FC00-0 / ...91-6FC00-0 / ...90-6KC00-0 (1000A)

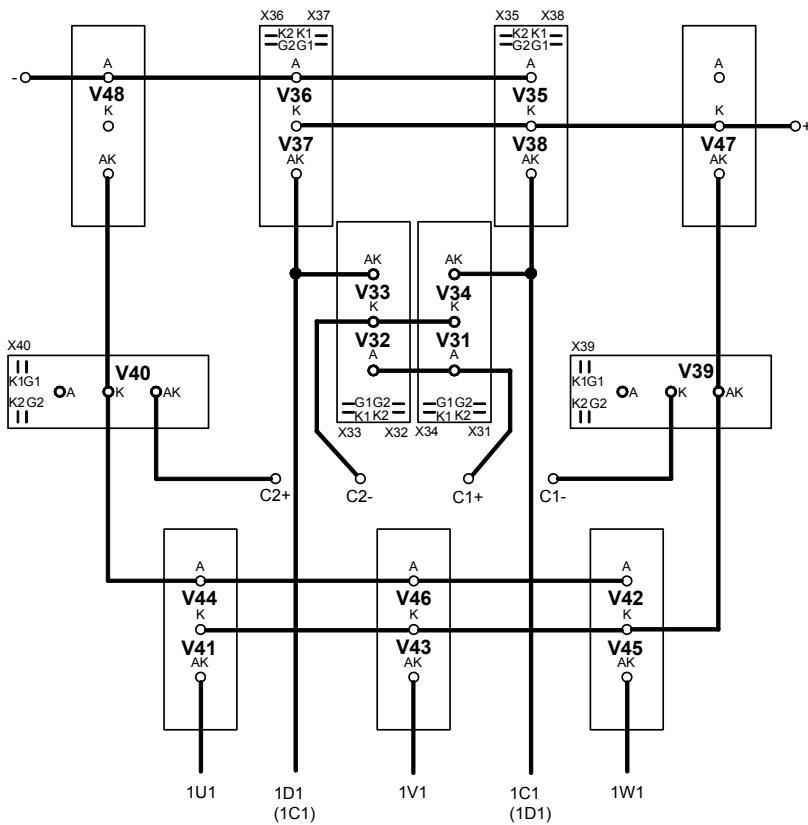

Devices 6RA70...95-6FC00-0 / ...95-6KC00-0 (2000A)

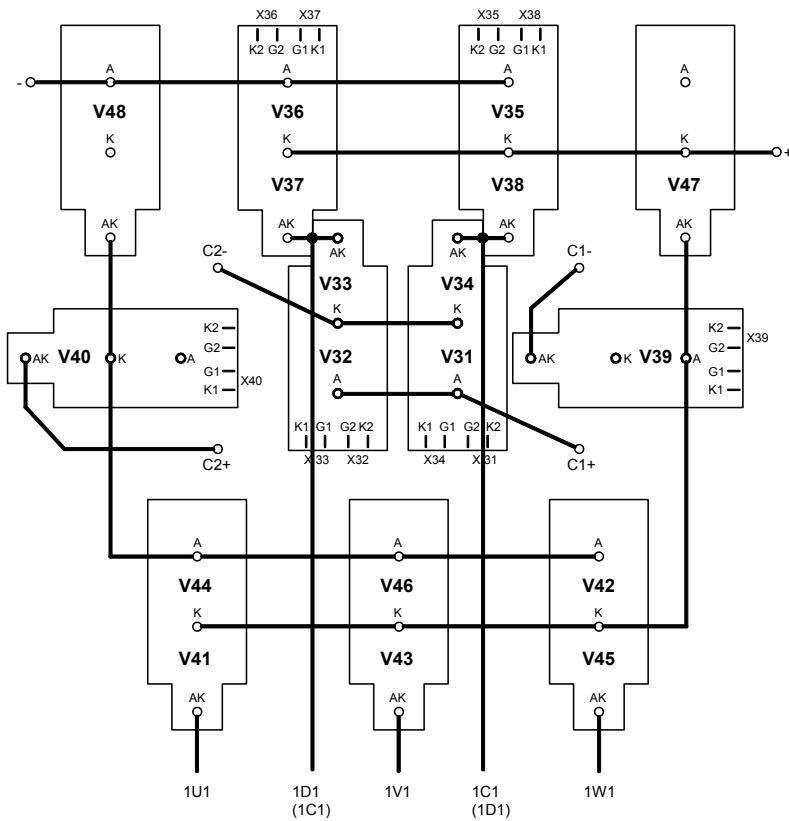

3.5 Applicable standards

EN 50178		Electronic equipment for use in power installations
EN 60068	Part 2 A93	Basic environmental testing procedures - Part 2: Tests
EN 60146	Part1	Semiconductor converters; general requirements and line-commutated converters; part 1-1: specifications of basic requirements
EN 61800	Part1	Adjustable speed electrical power drive systems: General requirements – Rating specifications for low voltage adjustable speed d.c. power drive systems
EN 60204		Machine directive
EN 60529	Part 4-2 A12.01	Degrees of protection provided by enclosures (EN 60529: 1991)
EN 60721		Classification of environmental conditions
EN 61140	Part1 A08.03	Protection against electric shock - Common aspects for installation and equipment Classification of electrical and electronic equipment
EN 61800	Part 3	Adjustable speed electrical power drive systems - Part 3: EMC product standard including specific test methods
DIN VDE 0110	Part 1 and 2 A01.89	Insulation coordination for equipment within low-voltage systems - Coordination of high-frequency voltage stress
SN36350		Environmentally compatible product design
UL 508 C		Power conversion equipment

3.6 Certification

The products referred to in this document are manufactured and operated in accordance with DIN ISO 9001 (Certificate Register No.: 257-0).

3.7 Abbreviations

CE	Communauté Européenne
CULus	in the case of products ready for connection, testing by UL in accordance with UL and CSA standards
UL	Underwriters Laboratories
CCP	Converter Commutation Protector
IGBT	insulated gate bipolar transistor

4 Shipment, unpacking

The devices are packed in the production works according to the relevant ordering data. A product packing label is attached to the box.

Protect the package against severe jolts and shocks during shipment, e.g. when setting it down.

Carefully observe the information on the packaging relating to transportation, storage and proper handling.

The device can be installed after it has been unpacked and the shipment checked for completeness and/or damage.

The packaging materials consist of cardboard and corrugated paper and can be disposed of according to locally applicable waste disposal regulations.

If you discover that the converter has been damaged during shipment, please inform your shipping agent immediately.

5 Installation



CAUTION

Failure to lift the converter in the correct manner can result in bodily injury and/or property damage.

The device must always be lifted by properly trained personnel using the appropriate equipment (i.e. protective gloves, etc.).



To preclude the risk of deformation damage to the housing, the lifting lugs used to raise them must not be subjected to any horizontal forces.

The user is responsible for installing the converter, motor, transformer as well as other equipment according to safety regulations (e.g. DIN, VDE), as well as all other relevant national or local regulations regarding cable dimensioning and protection, grounding, isolating switch, overcurrent protection, etc.

The converter must be installed in accordance with the relevant safety regulations (e.g. DIN, VDE), as well as all other relevant national and local regulations. It must be ensured that the grounding, cable dimensioning and appropriate short-circuit protection have been implemented to guarantee operational safety and reliability.

Installation of SIMOREG devices in cabinets in accordance with UL 508 C standards

When the drive is provided in a panel (enclosure), the panel is ventilated and designated "Type 1".

The minimum size panel (enclosure) to be used with the drive is 600 mm length, 600 mm width, 2200 mm height.

5.1 Dimension diagrams

600A / 1000A / 1200A Devices:

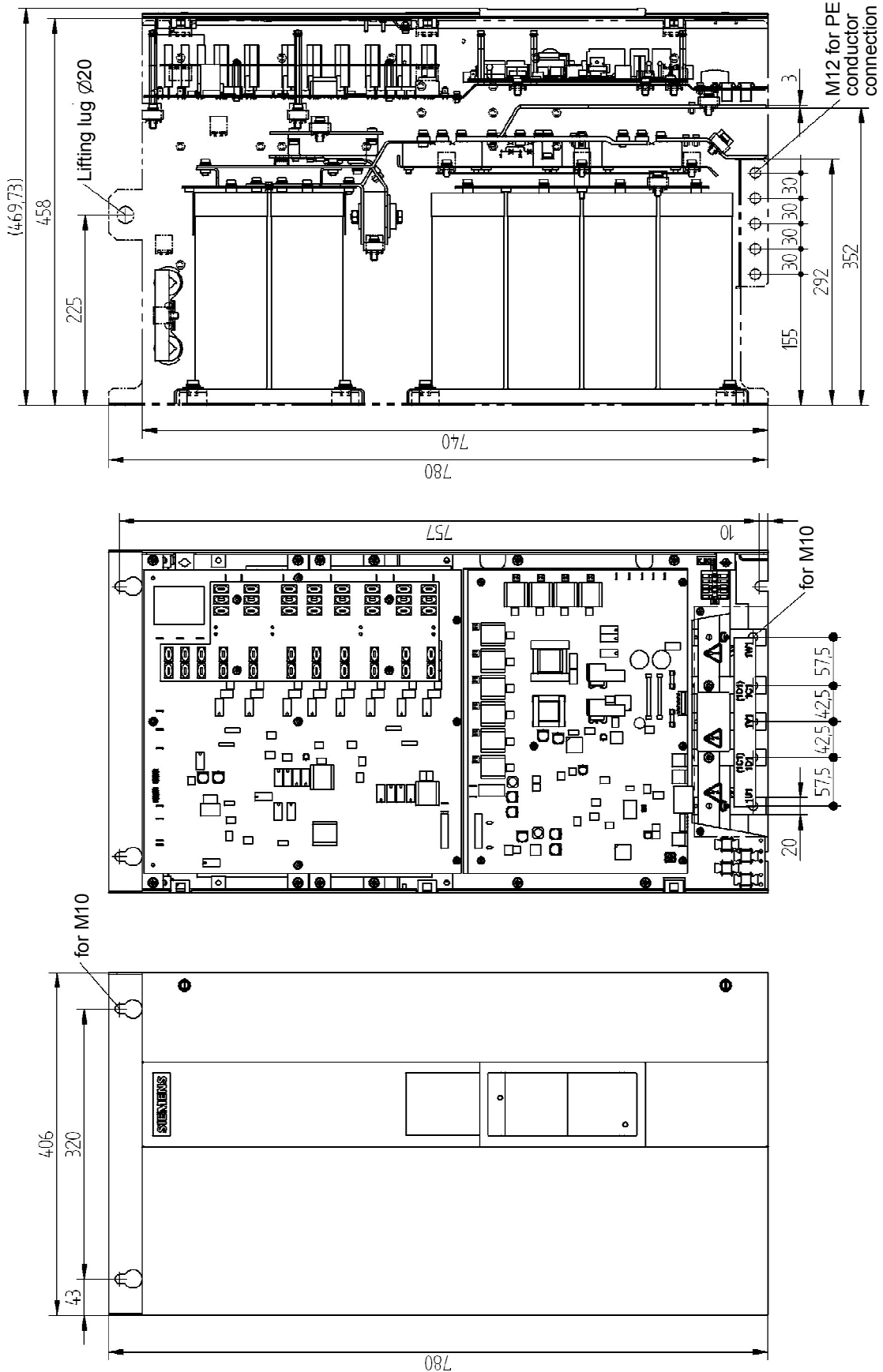

2000A Devices:

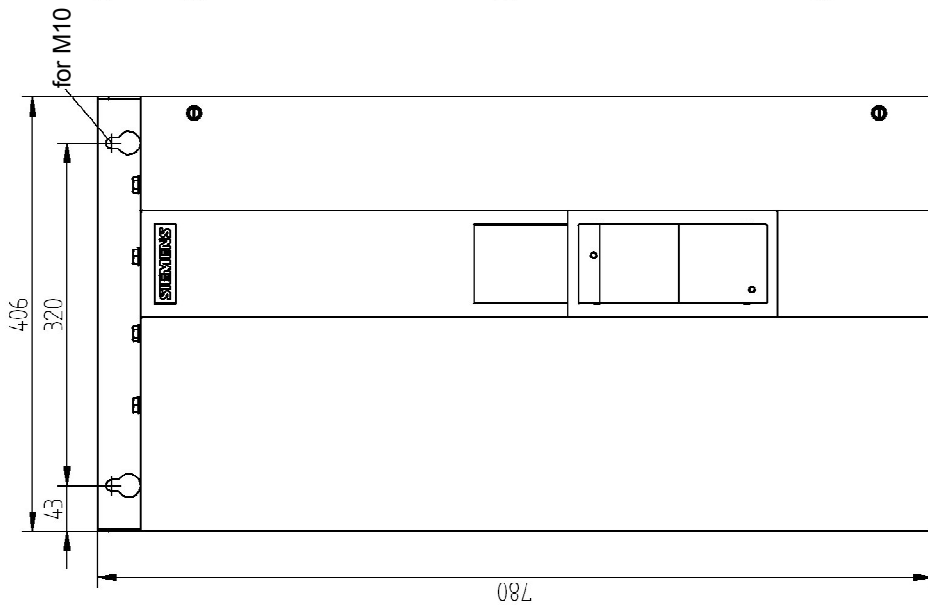
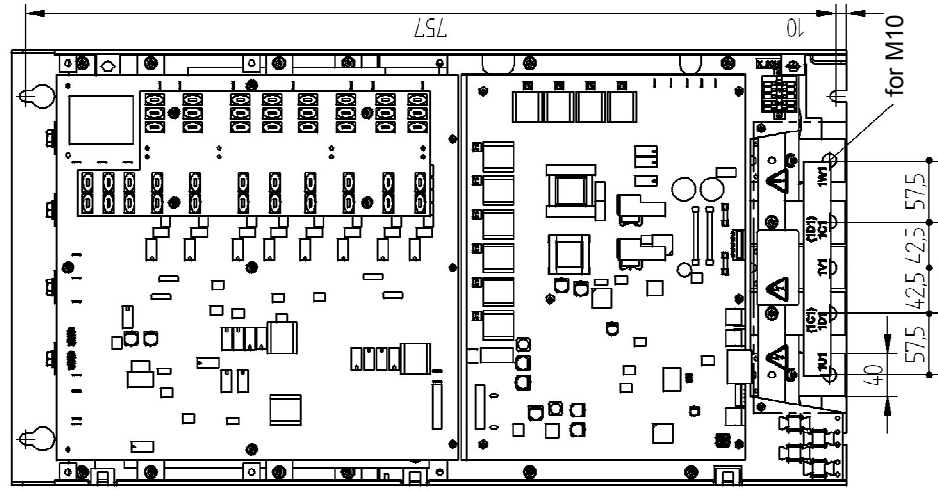
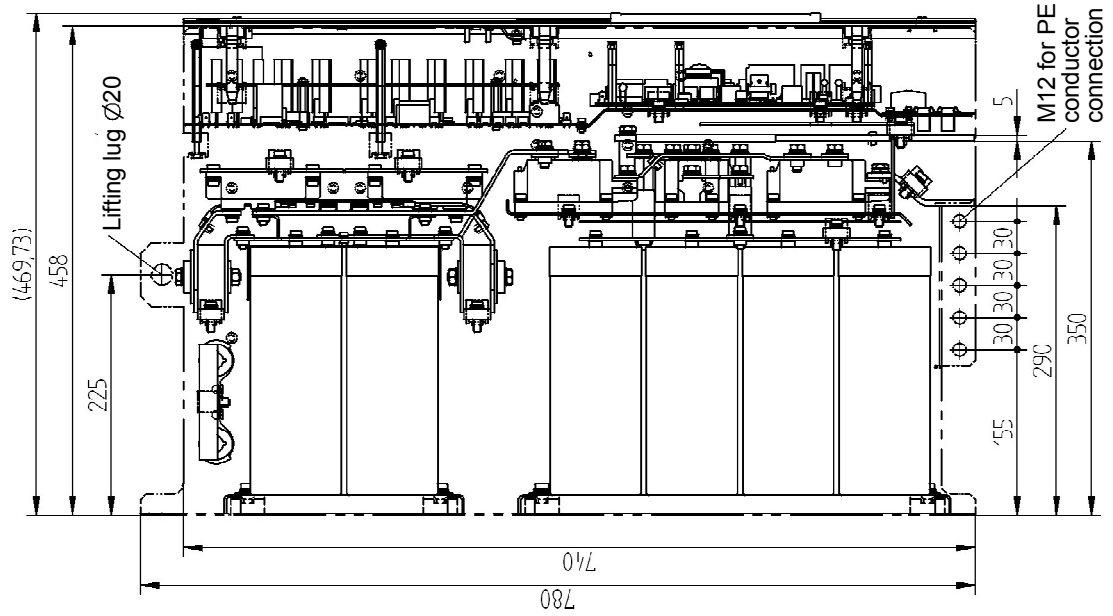

6 Connections



WARNING

The converters are operated at high voltages.

Disconnect the power supply before making any connections!

Only qualified personnel who are thoroughly familiar with all safety notices contained in the operating instructions as well as erection, installation, operating and maintenance instructions should be allowed to work on these devices.

Non-observance of the safety instructions can result in death, severe personal injury or substantial property damage.

Failure to make the correct connections may result in irreparable damage to the unit.

Voltage may be present at the power and control terminals even when the motor is stopped.



The snubber capacitors in the SIMOREG converter might still be carrying hazardous voltage after isolation from the supply. For this reason, the converter must not be opened for at least two minutes after switch-off.

When working on the open converter, remember that live parts are exposed. The unit must always be operated with the standard front covers in place.

The user is responsible for ensuring that the SIMOREG CCP, the motor, SIMOREG converter and other devices are installed and connected up in accordance with the approved codes of practice of the country concerned and any other regional or local codes that may apply. Special attention must be paid to proper conductor sizing, fusing, grounding, isolation and disconnection measures and to overcurrent protection.

These converters control rotating mechanical components (drives). Death, serious bodily injury or substantial property damage may occur if the instructions in the relevant operating manuals are not observed.

The successful and safe operation of this equipment is dependent on careful transportation, proper storage and installation as well as correct operation and maintenance.

Take also note of the warning and danger notices in the manual of the SIMOREG converter

NOTE

Please take note of the "Installation instructions for proper EMC installation of drives" in section 6.1 of the manual of the SIMOREG DC-MASTER.

Lengths of connecting cables between connections 1U1, 1V1, 1W1, 1C1, 1D1 on the SIMOREG basic unit and the SIMOREG CCP

The connecting cables between the basic unit and the SIMOREG CCP also serve as commutation inductance for an extinction process and must therefore be of a defined length.

The cable length applies per cable for 1U1, 1V1, 1W1, 1C1, 1D1 and can be calculated from the diagram below. The final cable length must measure between l_{min} and l_{max} (see also example below).

Note: Parameter U578 must be set to the correct value before the cable length can be accurately determined.

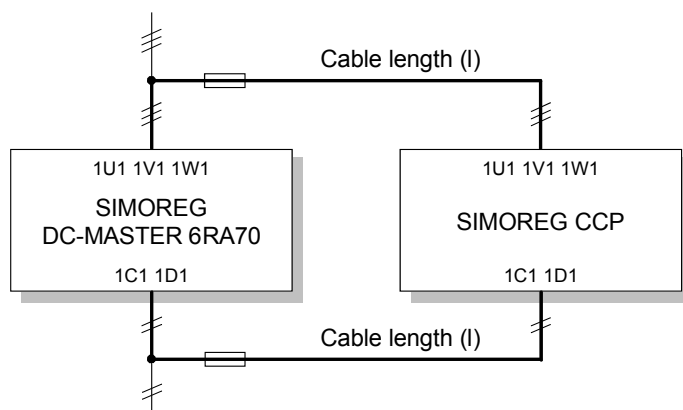
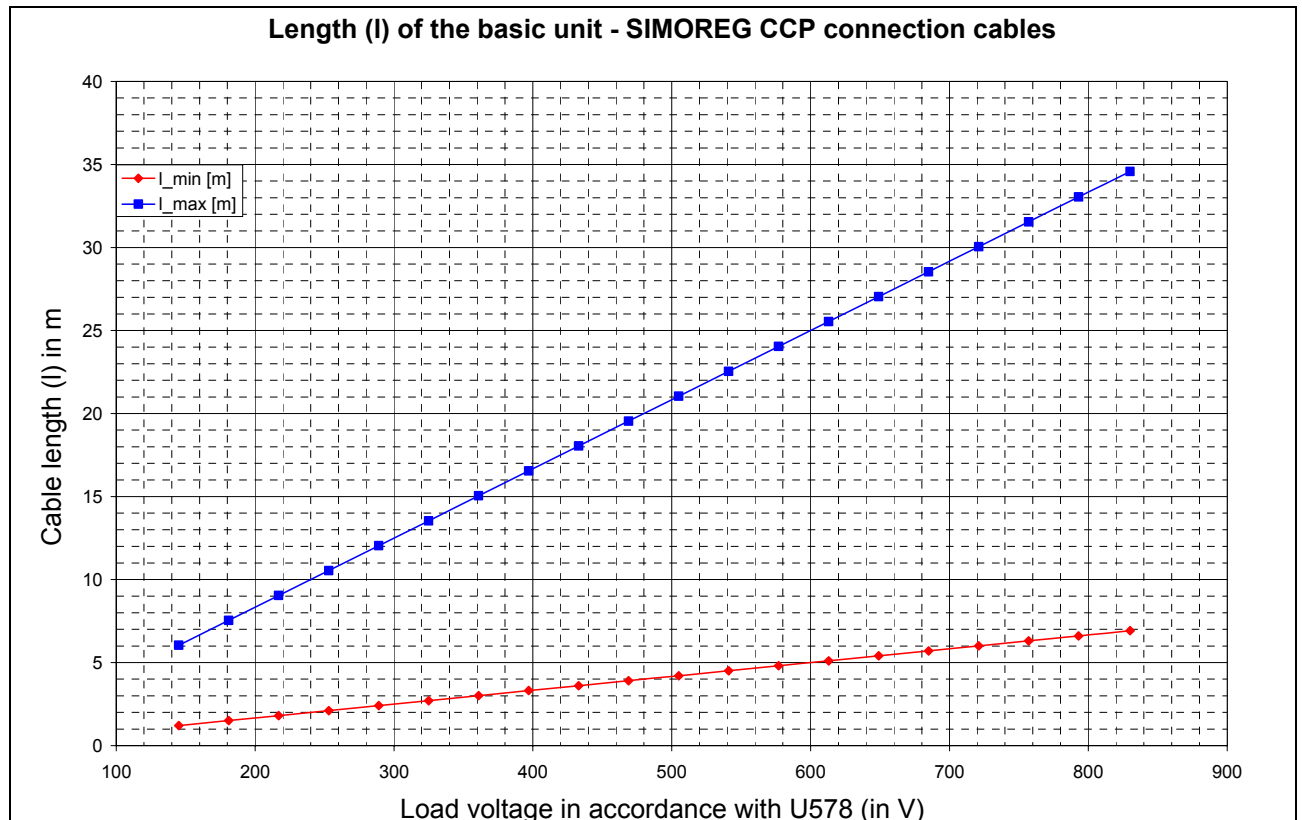

Cable length for connection of AC terminals l_{UVW}

Cable length for connection of DC terminals l_{CD}

The following rule of thumb applies:

The total cable length calculated from l_{UVW} and l_{CD} must equal twice the value of l ($2 \cdot l = l_{UVW} + l_{CD}$). It is possible, for example, to reduce the line-side connecting cables to the minimum possible or permissible length (e.g. using busbars) and to extend the motor-side cables accordingly to the required length.

Example:

The minimum required cable length l_{min} is 3 m.

- Make connecting cables 3m long each for 1U1, 1V1, 1W1, 1C1 and 1D1.
- Or: Make connecting cables 1m long each for 1U1, 1V1 and 1W1, and 5m long each for 1C1 and 1D1

6.1 Recommended connection

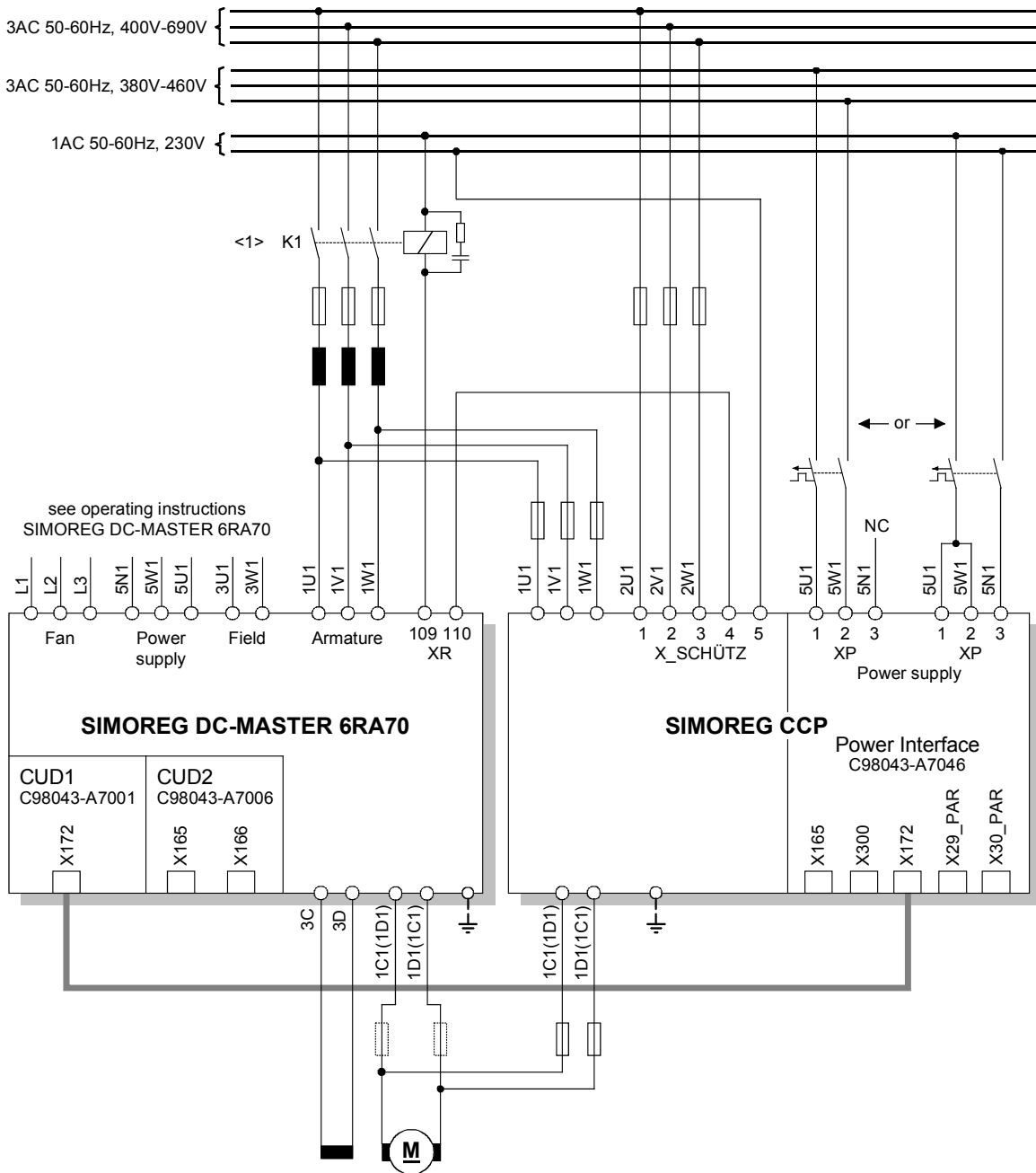

<1>

CAUTION

Operation without main contactor (circuit breaker) is not permitted. The control voltage for the main contactor (or the circuit-breaker) must always be led via the XR terminal (connections 109 and 110) of the SIMOREG device and the X_SCHÜTZ terminal (connections 4 and 5) of the SIMOREG CCP. For parallel connection (see Section 6.2), all SIMOREG devices must be included in this interlock chain.

In applications with SIMOREG CCP, if a fault occurs, the basic unit or the SIMOREG CCP must be able to reliably separate the arrangement from the supply line voltage.

Also note that the total of the delay times for all switching elements contained in the control loop must not exceed the time set on the P089 parameter

6.1.1 Variants for the interconnection of the K1 main contactor (circuit-breaker)

after the supply transformer

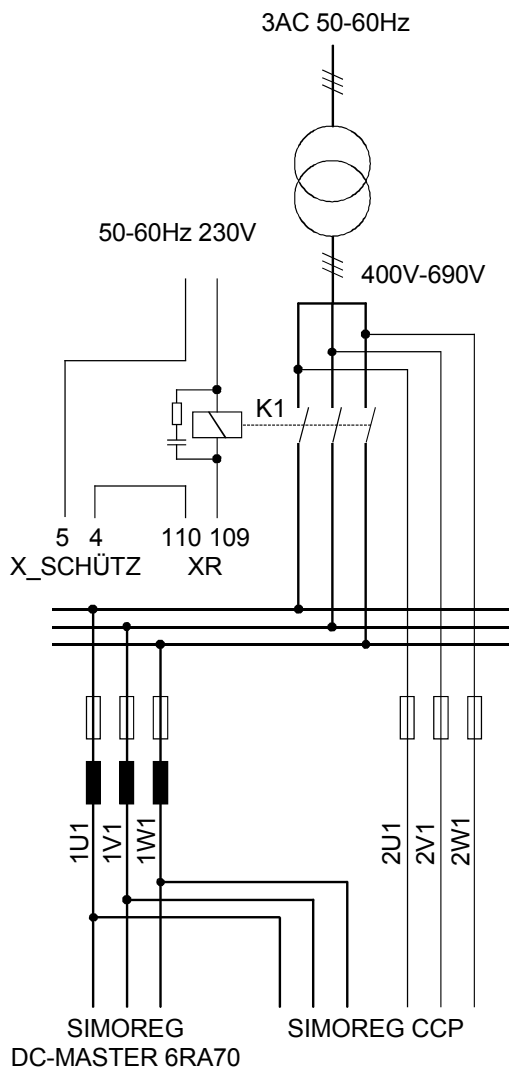

in front of the supply transformer

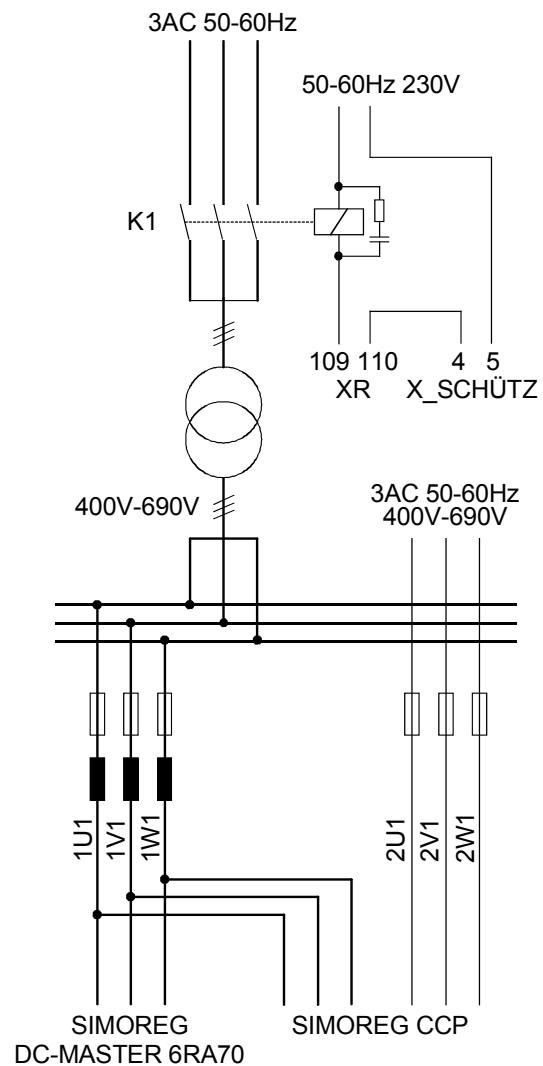

6.1.2 Suggestion for connection if a Siemens 3WL circuit breaker is used

If circuit breakers from other manufacturers are used, the connection suggestion described here applies analogously.

It must be ensured that the circuit breaker is fitted with a ready indicator (S20, ordering option Z=C22) and an undervoltage release (F3 short-time delayed or F4 with shortest possible delay time; version defined by means of the 15th place in the MLFB of the circuit breaker).

See also operating instructions for the 3WL circuit breaker, order number: 3ZX1812-0WL00-0AN0
Section 8.4 Auxiliary release / electrical closing lockout
(<http://support.automation.siemens.com/WWW/view/de/8912465>)

with F4 undervoltage release:

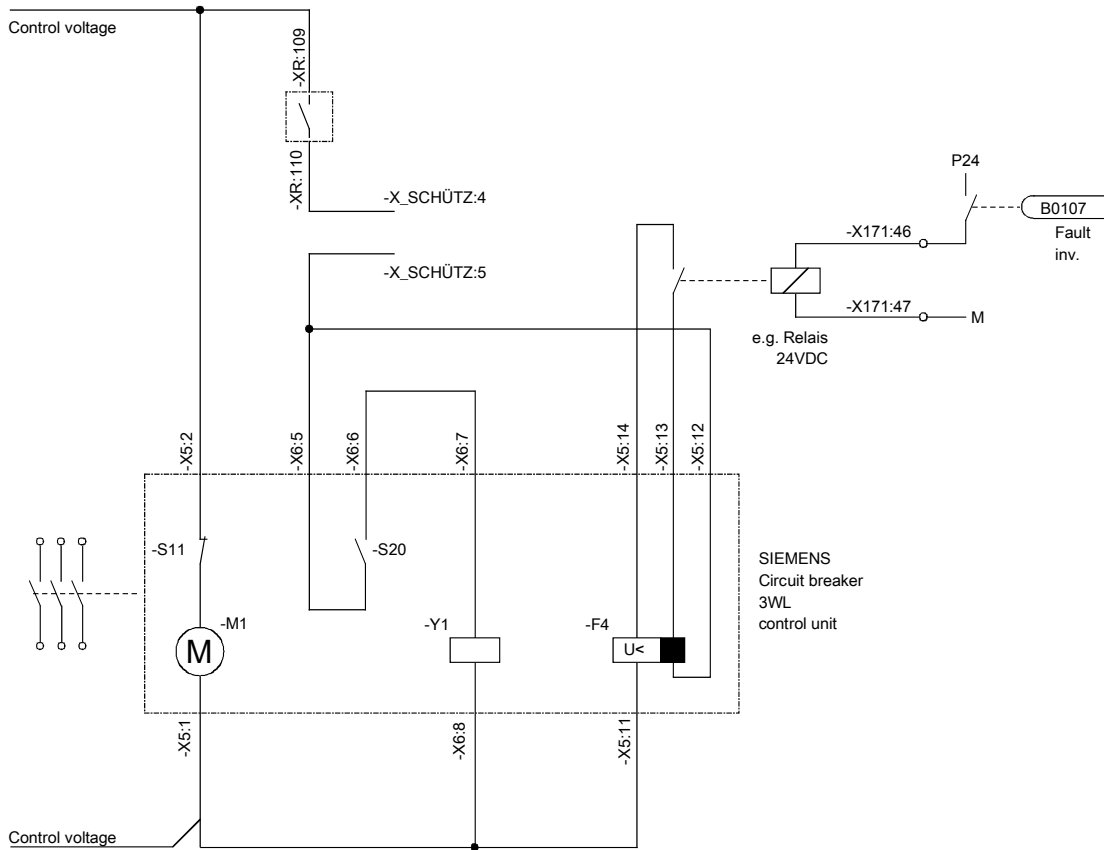

with F3 undervoltage release:

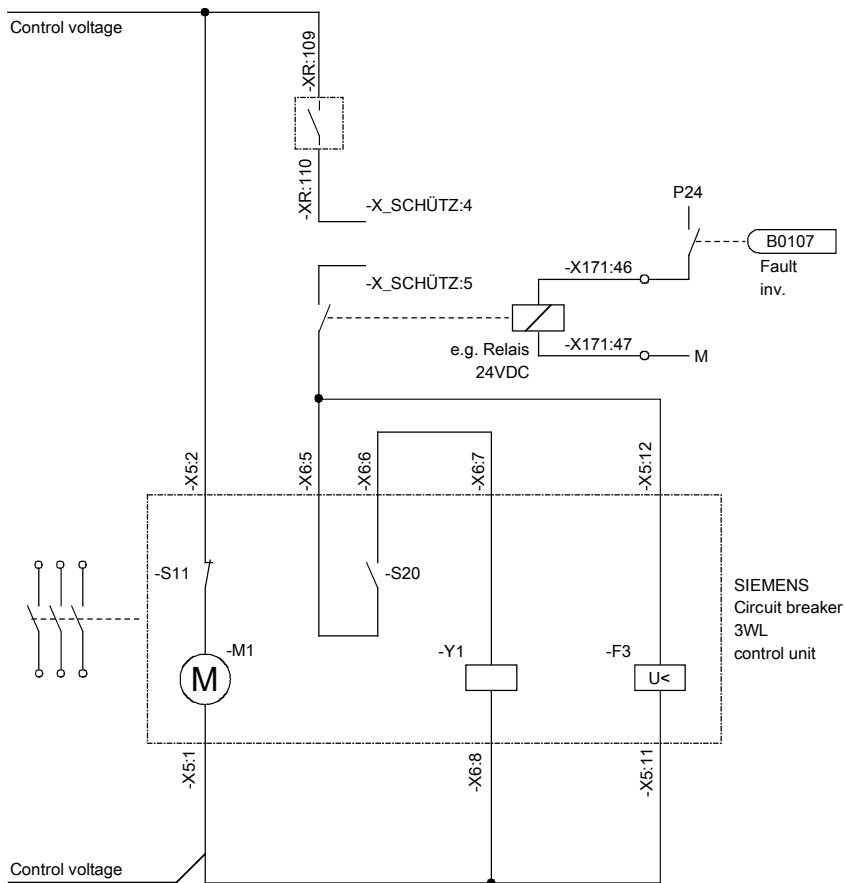

6.2 Connection of devices in parallel

A SIMOREG CCP is connected directly parallel to each of the converter devices connected in parallel (SIMOREG devices).

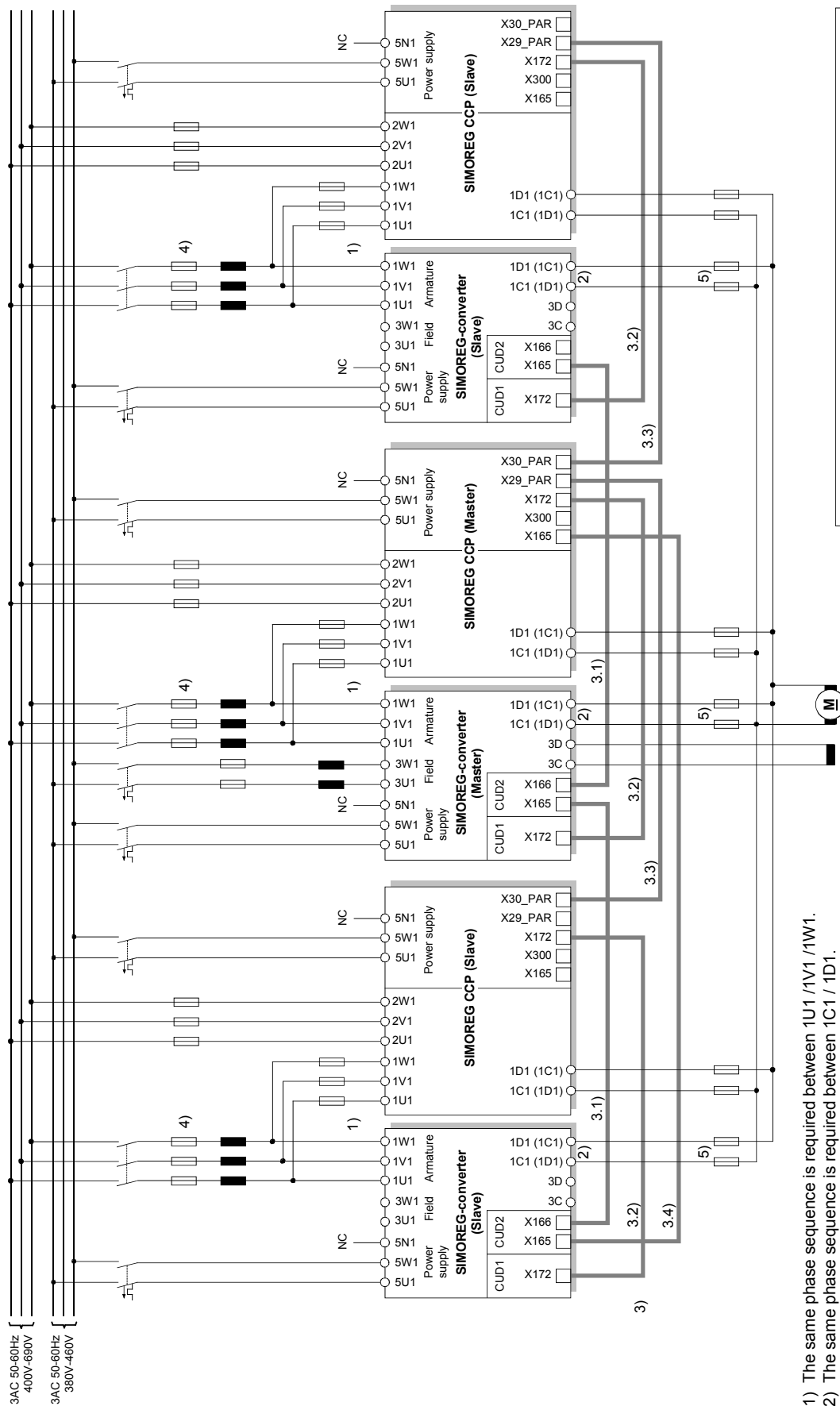

- 1) The same phase sequence is required between 1U1 /1V1 /1W1.
 - 2) The same phase sequence is required between 1C1 / 1D1.
 - 3) Connecting cables:
 - 3.1) Connection of the SIMOREG devices in parallel
 - 3.2) Serial connection of SIMOREG device -> SIMOREG CCP
 - 3.3) Extinction pulse interface
 - 3.4) Group firing pulse interface
 - 4) These fuses may only be used on converters up to 850A
 - 5) For converters up to 850A in 4Q operation only
- For further connections for the SIMOREG devices, see operating instructions for the SIMOREG DC-MASTER 6RA70

6.3 Fuses

Fuses in the armature circuit and motor circuit

Recommended SIEMENS semiconductor fuses depending on the SIMOREG CCP used:

Device order No. (MRPD)	Rated current	Rated voltage	Fuses 1U1, 1V1, 1W1	Fuses 1C1, 1D1
6RA7085-6FC00-0	600 A	460 V	3NE3335 (560A / 1000V)	3NE7431 (350A / 2000V)
6RA7091-6FC00-0	1200 A	460 V	3NE3335 (560A / 1000V)	3NE7431 (350A / 2000V)
6RA7090-6KC00-0	1000 A	690 V	3NE3335 (560A / 1000V)	3NE7431 (350A / 2000V)
6RA7095-6FC00-0	2000 A	460 V	3NE3338-8 (800A / 800V)	3NE7648-1 (525A / 2000V)
6RA7095-6KC00-0	2000 A	690 V	3NE3338-8 (800A / 800V)	3NE7648-1 (525A / 2000V)

Note:

Use of the types of fuse indicated in earlier versions of the operating instructions for the SIMOREG CCP is no longer recommended.

Fuses for precharging

10A line protection, e.g. Diazed 5SD604 type

Fuses F1 and F2 in the power interface

Only UL-listed or UL-recognized fuses may be used for UL-listed devices.

Wickmann 198 1A / 250V 5 x 20 mm slow

Wickmann 343 1A / 250 V 6.3 x 32 mm slow

Schurter FSD 1A / 250V 5 x 20 mm slow, ordering designation 0034.3987

Schurter FST 1A / 250 V 5 x 20 mm slow, ordering designation 0034.3117

6.4 Location of the terminals, connectors and fuses

Module C98043-A7046 Power Interface SIMOREG CCP

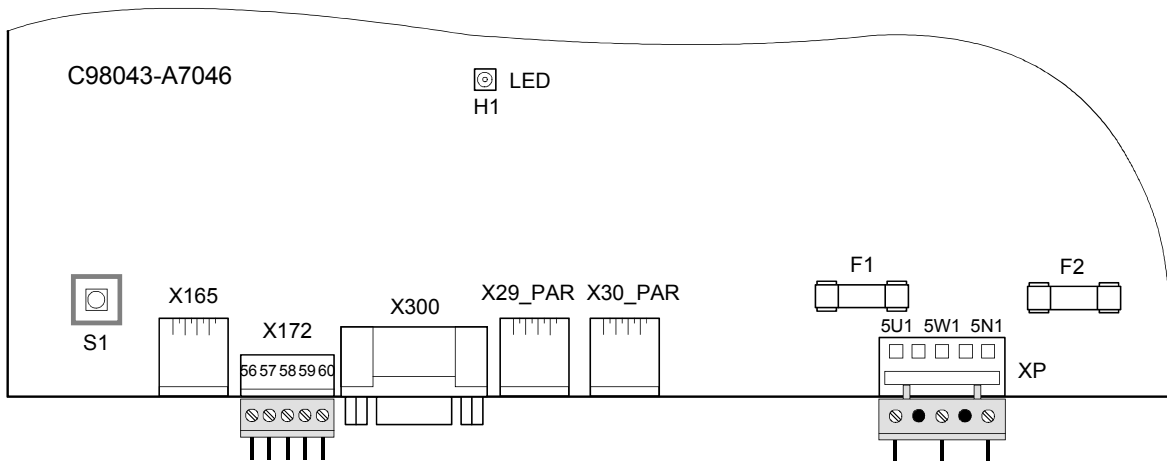

6.5 Terminal assignment, connectors



WARNING

The converter might sustain serious or irreparable damage if connected incorrectly.
The power cables and/or busbars must be secured mechanically outside the converter.

Power section

Terminal type:

600A / 1000A / 1200A Devices Through-hole for M10 (3x25 copper bus)

2000A Devices Through-hole for M10 (5x40 copper bus)

The converters are designed for a permanent power supply connection according to DIN VDE 0160 Section 6.5.2.1

PE conductor connection: Minimum cross-section 10mm². (see Section 5.1 for connection options)

The connection cross-sections must be determined according to the applicable regulations, e.g. DIN VDE 100 Part 523, DIN VDE 0276 Part 1000.

The connection lengths can be obtained from the diagram in Chapter 6 – Connections

Function	Terminal	Connection values/Remarks
Armature supply input	1U1 1V1 1W1	} see technical data in Section 3.3
PE conductor	⊕	
Armature circuit motor connection	1C1 (1D1) 1D1 (1C1)	

Precharging, main contactor / circuit breaker

WAGO 264-105 terminal strip

Conductor cross-section max. 2.5mm²
AWG max. 12

Length of insulation stripped off 8–9mm

Function	Connection	Terminal X_SCHÜTZ	Connection values / Remarks
Power connection for precharging	1 2 3	2U1 2V1 2W1	Conductor cross-section 1.5mm ² 10A fuse (see Section 6.3) Connection values like power section SIMOREG CCP (see above)
Control circuit for main contactor/ circuit breaker	4 5		For wiring of main contactor/ circuit breaker, see connecting suggestion in Section 6.1

Electronics power supply

Terminal type: Type 49 plug-in terminal
 Maximum cross-section 1.5mm², finely stranded

Module C98043-A7046 Power Interface SIMOREG CCP

Function	Connection	Terminal XP	Connection values/Remarks
Incoming supply 400V	— 1	5U1	2AC 380V (– 20%) to 460V (+15%); I _n =1A Internal fuse protection with F1, F2 on board C98043- A7046 (see Section 0) external fuse protection 6A, characteristic C recommended
	— 2	5W1	
	NC 3	5N1	
or			
Incoming supply 230V	 1	5U1	1AC 190V (– 20%) to 230V (+15%); I _n =2A Internal fuse protection with F1, F2 on board C98043- A7046 (see Section 0) external fuse protection 6A, characteristic C recommended
	2	5W1	
	3	5N1	

NOTE

In the case of line voltages which exceed the tolerance range specified in Section 3.3, the electronics supply voltage must be adjusted by means of transformers to the permissible value stated in Section 3.3. It is essential to use an isolating transformer for rated line voltages in excess of 460V.

The rated supply voltage for the armature must be set in parameter P078 (Index 001).

Serial interface RS485

Module C98043-A7046 Power Interface SIMOREG CCP

Function	Terminal X172	Connection values/Remarks
TX+	56	RS485, 4-wire send cable, positive differential output
TX-	57	RS485, 4-wire send cable, negative differential output
RX+/TX+	58	RS485, 4-wire receive cable, positive differential input
RX-/TX-	59	RS485, 4-wire receive cable, negative differential input
M	60	Ground

max. cable length 600m

The following must be observed: DIN 19245 Part 1

The potential difference between the data reference potentials M of all interfaces must not exceed -7V / +12V. If this cannot be guaranteed, then equipotential bonding must be provided.

Activate the serial interface by setting the protocol at parameter P790.

Cable:

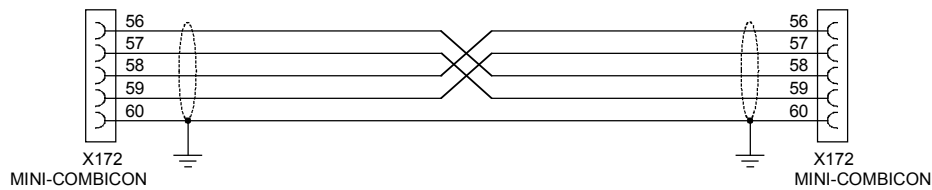

Programming interface for the software update (X300)

Serial interface RS232

9-pin SUBMIN D socket connector

Module C98043-A7046 Power Interface SIMOREG CCP

Con. pin X300	Function
2	Receive cable to RS232 (V.24) standard
5	Ground
7	Send cable to RS232 (V.24) standard

Cable:

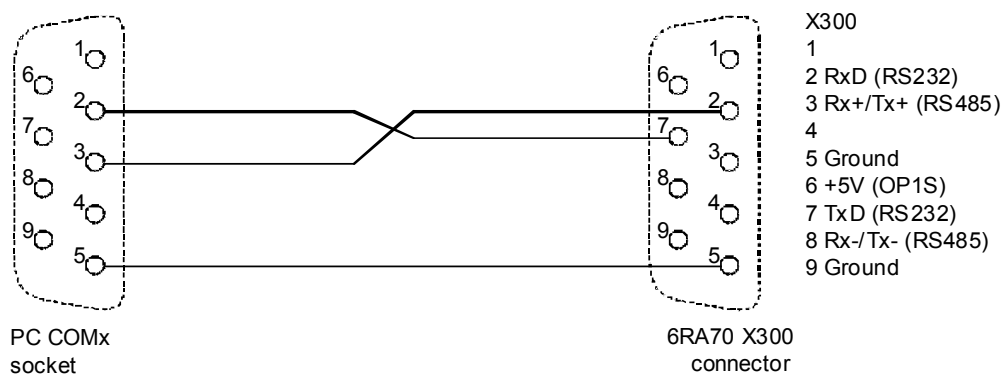

Use a shielded connecting cable. Ground shield at both ends.

Other connectors

Module C98043-A7046 Power Interface SIMOREG CCP

Connector	Function
X165	Group firing pulse interface to the SIMOREG 6RA70 (CUD2) Used only for parallel connection
X29_PAR	Extinguishing pulse interface for connecting SIMOREG CCPs in parallel The two connectors are connected in parallel.
X30_PAR	

7 Start-Up

7.1 General safety information for start-up

CAUTION

Before handling any boards, please make sure that your body is electrostatically discharged to protect electronic components against high voltages caused by electrostatic charges. The simplest way of doing this is to touch a conductive, grounded object (e.g. bare metal cabinet component immediately beforehand).

PCBs must not be allowed to come into contact with highly insulating materials (e.g. plastic foil, insulating table tops or clothing made of synthetic fibers).

PCBs may only be set down on electrically conducting surfaces.



WARNING

Hazardous voltages are present in this electrical equipment during operation. Non-observance of the safety instructions can result in death, severe personal injury or substantial property damage.

The converters must not be connected to a supply with earth-leakage circuit-breaker (VDE 0160, Section 6.5) since, in the event of a fault to frame or ground, the fault current may contain a DC component that will either prevent or hinder a higher-level e.l.c.b. from tripping. In this case, all loads connected to this e.l.c.b. have no protection either.

Only qualified personnel who are thoroughly familiar with all safety notices contained in the operating instructions as well as erection, installation, operating and maintenance instructions should be allowed to work on these devices.

The successful and safe operation of this equipment is dependent on careful transportation, proper storage and installation as well as correct operation and maintenance.



The converter is at a hazardous voltage level even when the line contactor is open. Before carrying out any maintenance or repair work, all converter power sources must be disconnected and locked out.

These instructions do not claim to list all of the measures required to ensure safe and reliable operation of the converter. For special applications, additional, supplementary information or instructions might be required. If problems do occur and you feel in any way uncertain, please contact your local Siemens office or representative.

The use of unauthorized parts in the repair of this converter and handling of the equipment by unqualified personnel can give rise to hazardous conditions which may cause death, severe personal injury or substantial property damage. All safety notices contained in this instruction manual and attached to the converter itself must be carefully observed.

Please read the safety information given in Section 1 of this instruction manual.

7.2 Operation by means of the SIMOREG device

For commissioning, operation, monitoring and diagnosis of the SIMOREG CCP, there are setting and observation parameters in the SIMOREG DC-MASTER 6RA70 unit. The status of the SIMOREG CCP is signaled via connectors and triggering of the SIMOREG CCP or defective states are signaled by means of fault and warning indications.

The data exchange necessary for this between the SIMOREG DC-MASTER 6RA70 and the SIMOREG CCP takes place via the serial interface.

7.2.1 Parameters

(Detailed description see below)

P790 *)	Protocol selection for interface of basic unit G-SST2
r799 *)	Diagnostic information for G-SST2
r812 *)	Receive data to G-SST2
n560	Software version of the SIMOREG CCP
n569	Factory number of the SIMOREG CCP
n570	MLFB (order number) of the SIMOREG CCP
n571	Rated supply voltage of the SIMOREG CCP
n572	Rated current of the SIMOREG CCP
n574	Status of the SIMOREG CCP
n575	Indication of the I _{2t} value of voltage limiting chopper 1 of the SIMOREG CCP
n576	Indication of the I _{2t} value of voltage limiting chopper 2 of the SIMOREG CCP
U577	Voltage setpoint for the upper response threshold of the SIMOREG CCP chopper
U578	Voltage setpoint for precharging the SIMOREG CCP surge absorbing capacitors
U580	Control word for commutation monitoring
U581	Diagnostics memory for commutation monitoring
U582	Reaction of commutation monitor
U583	Test command for the SIMOREG CCP

*) For the description of these parameters, see operating instructions for the SIMOREG DC-MASTER 6RA70 Section 11

Detailed description of the parameters

The specified software version applies to the software version of the SIMOREG DC-MASTER (basic unit)

PNU	Description	Value range [Unit] Steps	No. indices Factory setting Type	See Change (Access / Status)
n560 (2560)	Software version of the SIMOREG CCP [SW 2.1 and later] i001: Software version of the SIMOREG CCP i002: Software version of the SIMOREG CCP boot sector	0.0 to 9.9 0.1	Ind: 2 Type: O2	P052 = 3
n569 (2569)	Factory number of the SIMOREG CCP [SW 2.1 and later] i001: 1 st and 2 nd places of factory number i002: 3 rd and 4 th places of factory number i003: 5 th and 6 th places of factory number i004: 7 th and 8 th places of factory number i005: 9 th and 10 th places of factory number i006: 11 th and 12 th places of factory number i007: 13 th and 14 th places of factory number i008 bis i015: 0 i016: Checksum for factory number The factory number ASCII code is displayed in this parameter.		Ind: 16 Type: L2	P052 = 3
n570 (2570)	MLFB (order number) of the SIMOREG CCP [SW 2.1 and later] The corresponding MLFB is displayed in encoded form in this parameter.	250 to 254 1	Ind: none Type: O2	P052 = 3
n571 (2571)	Rated supply voltage of the SIMOREG CCP [SW 2.1 and later] Converter rated supply voltage as specified on rating plate of the SIMOREG CCP	10 to 830 [V] 1V	Ind: none Type: O2	P052 = 3

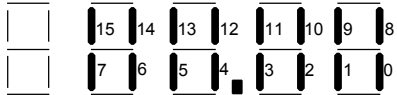
PNU	Description	Value range [Unit] Steps	No. indices Factory setting Type	See Change (Access / Status)
n572 (2572)	Rated current of the SIMOREG CCP [SW 2.1 and later] Converter rated DC current as specified on rating plate of the SIMOREG CCP	0.0 to 6553.5 [A] 0.1A	Ind: none Type: O2	P052 = 3
n574 (2574)	Status of the SIMOREG CCP [SW 2.1 and later] Representation on operator panel (PMU):  Segment ON or bit = 1: meaning specified below applies Segment OFF or bit = 0: meaning specified below does <u>not</u> apply Segment or bit 0 voltage at U, V, W terminals is OK 1 voltage at C – D is > +100V 2 voltage at C – D is < -100V 3 The surge absorbing capacitors have attained the set voltage 4 Extinguishing process is running 5 Connection between parallel SIMOREG CCPs correct 6 7 8 Parallel connection interface connected to the SIMOREG CCP 9 I2t value of voltage limiting chopper 1 is too high 10 I2t value of voltage limiting chopper 2 is too high 11 Contents of the memory of the technical data for the SIMOREG CCP (MLFB, rated values, serial number) valid 12 Precharging of the chopper capacitors completed 13 14 15 Note: This parameter has the same bit assignments as connector K0574.		Ind: none Type: V2	P052 = 3
n575 (2575)	Indication of the I2t value of voltage limiting chopper 1 of the SIMOREG CCP [SW 2.1 and later]	0 to 100 [%] 1%	Ind: none Type: O2	P052 = 3
n576 (2576)	Indication of the I2t value of voltage limiting chopper 2 of the SIMOREG CCP [SW 2.1 and later]	0 to 100 [%] 1%	Ind: none Type: O2	P052 = 3

PNU	Description	Value range [Unit] Steps	No. indices Factory setting Type	See Change (Access / Status)																																																																																																																														
U577 (2577)	<p>Voltage setpoint for the upper response threshold of the SIMOREG CCP chopper [SW 2.2 and later]</p> <p>The set voltage value determines the upper response threshold of the voltage limiter implemented in the SIMOREG CCP. This threshold limits the produced counter-voltage required during the extinguishing process of the CCP for armature current removal to a safe value for the basic unit and for the associated SIMOREG CCP. The required setting value depends on the blocking voltage strength of the power semiconductors used in the basic unit (SIMOREG DC-MASTER 6RA70) and in the SIMOREG CCP; this means that it depends on the device MLFB.</p> <p>The following table should be used to make the correct setting of this parameter.</p> <p>The existing device MLFB for the basic unit and the SIMOREG CCP produces two setting values, of which the smaller must be set at U577.</p> <p>Example: Basic unit MLFB: 6RA7085-6DV62-0 (r070=9) ⇒ U577=1300 V SIMOREG CCP-MLFB: 6RA7085-6FC00-0 (n570=250) ⇒ U577=1100 V this gives for the setting: <u>U577=1100 V</u></p> <p>Table for determining the setting value for U577:</p> <table border="1"> <thead> <tr> <th>MLFB 6RA70 SIMOREG DC-MASTER</th> <th>MLFB identification number (r070)</th> <th>Setting value for U577 [V]</th> </tr> </thead> <tbody> <tr><td>6RA7013-6DV62-0</td><td>1</td><td>1300</td></tr> <tr><td>6RA7018-6DV62-0</td><td>2</td><td>1300</td></tr> <tr><td>6RA7025-6DV62-0</td><td>3</td><td>1300</td></tr> <tr><td>6RA7028-6DV62-0</td><td>4</td><td>1300</td></tr> <tr><td>6RA7031-6DV62-0</td><td>5</td><td>1300</td></tr> <tr><td>6RA7075-6DV62-0</td><td>6</td><td>1300</td></tr> <tr><td>6RA7078-6DV62-0</td><td>7</td><td>1300</td></tr> <tr><td>6RA7081-6DV62-0</td><td>8</td><td>1300</td></tr> <tr><td>6RA7085-6DV62-0</td><td>9</td><td>1300</td></tr> <tr><td>6RA7087-6DV62-0</td><td>10</td><td>1300</td></tr> <tr><td>6RA7091-6DV62-0</td><td>11</td><td>1300</td></tr> <tr><td>6RA7093-4DV62-0</td><td>12</td><td>1500</td></tr> <tr><td>6RA7095-4DV62-0</td><td>13</td><td>1500</td></tr> <tr><td>6RA7025-6GV62-0</td><td>14</td><td>1700</td></tr> <tr><td>6RA7031-6GV62-0</td><td>15</td><td>1700</td></tr> <tr><td>6RA7075-6GV62-0</td><td>16</td><td>1700</td></tr> <tr><td>6RA7081-6GV62-0</td><td>17</td><td>1700</td></tr> <tr><td>6RA7085-6GV62-0</td><td>18</td><td>1700</td></tr> <tr><td>6RA7087-6GV62-0</td><td>19</td><td>1700</td></tr> <tr><td>6RA7090-6GV62-0</td><td>20</td><td>1700</td></tr> <tr><td>6RA7093-4GV62-0</td><td>21</td><td>1700</td></tr> <tr><td>6RA7095-4GV62-0</td><td>22</td><td>1700</td></tr> <tr><td>6RA7086-6KV62-0</td><td>23</td><td>2100</td></tr> <tr><td>6RA7090-6KV62-0</td><td>24</td><td>2100</td></tr> <tr><td>6RA7093-4KV62-0</td><td>25</td><td>2100</td></tr> <tr><td>6RA7095-4KV62-0</td><td>26</td><td>2100</td></tr> <tr><td>6RA7088-6LV62-0</td><td>27</td><td>2500</td></tr> <tr><td>6RA7093-4LV62-0</td><td>28</td><td>2500</td></tr> <tr><td>6RA7095-4LV62-0</td><td>29</td><td>2500</td></tr> <tr><td>6RA7018-6DS22-0</td><td>30</td><td>1300</td></tr> <tr><td>6RA7025-6DS22-0</td><td>31</td><td>1300</td></tr> <tr><td>6RA7028-6DS22-0</td><td>32</td><td>1300</td></tr> <tr><td>6RA7031-6DS22-0</td><td>33</td><td>1300</td></tr> <tr><td>6RA7075-6DS22-0</td><td>34</td><td>1300</td></tr> <tr><td>6RA7078-6DS22-0</td><td>35</td><td>1300</td></tr> <tr><td>6RA7081-6DS22-0</td><td>36</td><td>1300</td></tr> <tr><td>6RA7085-6DS22-0</td><td>37</td><td>1300</td></tr> <tr><td>6RA7087-6DS22-0</td><td>38</td><td>1300</td></tr> <tr><td>6RA7091-6DS22-0</td><td>39</td><td>1300</td></tr> <tr><td>6RA7093-4DS22-0</td><td>40</td><td>1500</td></tr> <tr><td>6RA7095-4DS22-0</td><td>41</td><td>1500</td></tr> </tbody> </table>	MLFB 6RA70 SIMOREG DC-MASTER	MLFB identification number (r070)	Setting value for U577 [V]	6RA7013-6DV62-0	1	1300	6RA7018-6DV62-0	2	1300	6RA7025-6DV62-0	3	1300	6RA7028-6DV62-0	4	1300	6RA7031-6DV62-0	5	1300	6RA7075-6DV62-0	6	1300	6RA7078-6DV62-0	7	1300	6RA7081-6DV62-0	8	1300	6RA7085-6DV62-0	9	1300	6RA7087-6DV62-0	10	1300	6RA7091-6DV62-0	11	1300	6RA7093-4DV62-0	12	1500	6RA7095-4DV62-0	13	1500	6RA7025-6GV62-0	14	1700	6RA7031-6GV62-0	15	1700	6RA7075-6GV62-0	16	1700	6RA7081-6GV62-0	17	1700	6RA7085-6GV62-0	18	1700	6RA7087-6GV62-0	19	1700	6RA7090-6GV62-0	20	1700	6RA7093-4GV62-0	21	1700	6RA7095-4GV62-0	22	1700	6RA7086-6KV62-0	23	2100	6RA7090-6KV62-0	24	2100	6RA7093-4KV62-0	25	2100	6RA7095-4KV62-0	26	2100	6RA7088-6LV62-0	27	2500	6RA7093-4LV62-0	28	2500	6RA7095-4LV62-0	29	2500	6RA7018-6DS22-0	30	1300	6RA7025-6DS22-0	31	1300	6RA7028-6DS22-0	32	1300	6RA7031-6DS22-0	33	1300	6RA7075-6DS22-0	34	1300	6RA7078-6DS22-0	35	1300	6RA7081-6DS22-0	36	1300	6RA7085-6DS22-0	37	1300	6RA7087-6DS22-0	38	1300	6RA7091-6DS22-0	39	1300	6RA7093-4DS22-0	40	1500	6RA7095-4DS22-0	41	1500	850 to 1600 [V] 1V	Ind: none FS=1600 Type: O2	P052 = 3 P051 = 40 Online
MLFB 6RA70 SIMOREG DC-MASTER	MLFB identification number (r070)	Setting value for U577 [V]																																																																																																																																
6RA7013-6DV62-0	1	1300																																																																																																																																
6RA7018-6DV62-0	2	1300																																																																																																																																
6RA7025-6DV62-0	3	1300																																																																																																																																
6RA7028-6DV62-0	4	1300																																																																																																																																
6RA7031-6DV62-0	5	1300																																																																																																																																
6RA7075-6DV62-0	6	1300																																																																																																																																
6RA7078-6DV62-0	7	1300																																																																																																																																
6RA7081-6DV62-0	8	1300																																																																																																																																
6RA7085-6DV62-0	9	1300																																																																																																																																
6RA7087-6DV62-0	10	1300																																																																																																																																
6RA7091-6DV62-0	11	1300																																																																																																																																
6RA7093-4DV62-0	12	1500																																																																																																																																
6RA7095-4DV62-0	13	1500																																																																																																																																
6RA7025-6GV62-0	14	1700																																																																																																																																
6RA7031-6GV62-0	15	1700																																																																																																																																
6RA7075-6GV62-0	16	1700																																																																																																																																
6RA7081-6GV62-0	17	1700																																																																																																																																
6RA7085-6GV62-0	18	1700																																																																																																																																
6RA7087-6GV62-0	19	1700																																																																																																																																
6RA7090-6GV62-0	20	1700																																																																																																																																
6RA7093-4GV62-0	21	1700																																																																																																																																
6RA7095-4GV62-0	22	1700																																																																																																																																
6RA7086-6KV62-0	23	2100																																																																																																																																
6RA7090-6KV62-0	24	2100																																																																																																																																
6RA7093-4KV62-0	25	2100																																																																																																																																
6RA7095-4KV62-0	26	2100																																																																																																																																
6RA7088-6LV62-0	27	2500																																																																																																																																
6RA7093-4LV62-0	28	2500																																																																																																																																
6RA7095-4LV62-0	29	2500																																																																																																																																
6RA7018-6DS22-0	30	1300																																																																																																																																
6RA7025-6DS22-0	31	1300																																																																																																																																
6RA7028-6DS22-0	32	1300																																																																																																																																
6RA7031-6DS22-0	33	1300																																																																																																																																
6RA7075-6DS22-0	34	1300																																																																																																																																
6RA7078-6DS22-0	35	1300																																																																																																																																
6RA7081-6DS22-0	36	1300																																																																																																																																
6RA7085-6DS22-0	37	1300																																																																																																																																
6RA7087-6DS22-0	38	1300																																																																																																																																
6RA7091-6DS22-0	39	1300																																																																																																																																
6RA7093-4DS22-0	40	1500																																																																																																																																
6RA7095-4DS22-0	41	1500																																																																																																																																

PNU	Description	Value range [Unit] Steps	No. indices Factory setting Type	See Change (Access / Status)
	6RA7025-6GS22-0	42	1700	
	6RA7031-6GS22-0	43	1700	
	6RA7075-6GS22-0	44	1700	
	6RA7081-6GS22-0	45	1700	
	6RA7085-6GS22-0	46	1700	
	6RA7087-6GS22-0	47	1700	
	6RA7090-6GS22-0	48	1700	
	6RA7093-4GS22-0	49	1700	
	6RA7095-4GS22-0	50	1700	
	6RA7086-6KS22-0	51	2100	
	6RA7088-6KS22-0	52	2100	
	6RA7093-4KS22-0	53	2100	
	6RA7095-4KS22-0	54	2100	
	6RA7088-6LS22-0	55	2500	
	6RA7093-4LS22-0	56	2500	
	6RA7095-4LS22-0	57	2500	
	6RA7096-4GV62-0	58	1700	
	6RA7096-4GS22-0	59	1700	
	6RA7000-0MV62-0	60	2900	
	6RA7095-4GS22-5	96	1700	
	6RA7095-4KS22-5	97	2100	
	6RA7095-4LS22-5	98	2500	
	6RA7096-4GS22-5	99	1700	
	6RA7018-6FV62-0	101	1500	
	6RA7025-6FV62-0	102	1500	
	6RA7028-6FV62-0	103	1500	
	6RA7031-6FV62-0	104	1500	
	6RA7075-6FV62-0	105	1500	
	6RA7078-6FV62-0	106	1500	
	6RA7082-6FV62-0	107	1500	
	6RA7085-6FV62-0	108	1500	
	6RA7087-6FV62-0	109	1500	
	6RA7091-6FV62-0	110	1500	
	6RA7018-6FS22-0	111	1500	
	6RA7025-6FS22-0	112	1500	
	6RA7028-6FS22-0	113	1500	
	6RA7031-6FS22-0	114	1500	
	6RA7075-6FS22-0	115	1500	
	6RA7078-6FS22-0	116	1500	
	6RA7082-6FS22-0	117	1500	
	6RA7085-6FS22-0	118	1500	
	6RA7087-6FS22-0	119	1500	
	6RA7091-6FS22-0	120	1500	
	6RA7098-4DV62-0	121	1500	
	6RA7097-4GV62-0	122	1700	
	6RA7097-4KV62-0	123	2100	
	6RA7096-4MV62-0	124	2100	
	6RA7098-4DS22-0	125	1500	
	6RA7097-4GS22-0	126	1700	
	6RA7097-4KS22-0	127	2100	
	6RA7096-4MS22-0	128	2900	
	6RA7095-4MV62-0	129	2900	
	MLFB	MLFB identification		
	SIMOREG CCP	number (n570)	Setting value for U577 [V]	
	6RA7085-6FC00-0	250	1100	
	6RA7091-6FC00-0	251	1100	
	6RA7095-6FC00-0	252	1100	
	6RA7090-6KC00-0	253	1600	
	6RA7095-6KC00-0	254	1600	
	Note: The setting value for U577 using the above table determines the maximum permitted value of the limiting voltage for the associated device.			

PNU	Description	Value range [Unit] Steps	No. indices Factory setting Type	See Change (Access / Status)																																						
U578 (2578)	<p>Voltage setpoint for precharging the SIMOREG CCP surge absorbing capacitors [SW 2.2 and later]</p> <p>The set voltage value determines the minimum required charge voltage for successful thyristor extinguishing for the surge absorbing capacitors present in the SIMOREG CCP. This value is used as setpoint for the two-step controller that handles the precharging of the surge absorbing capacitors using the supply line voltage.</p> <p>The maximum achievable precharging voltage is limited by the rectified mean value of the actual line voltage (minimum value in accordance with the lower tolerance limit at P351).</p> <p>The value to be set for the U578 parameter must be determined as follows using the characteristic curve diagrams shown in the appendix for these operating instructions.</p> <p>First of all, the numbers of the associated characteristic diagram must be selected from the following table for the SIMOREG CCP used (MLFB according to parameter n570 or according to rating plate) and for the rated armature voltage of the motor according to parameter P101.</p> <table border="1"> <thead> <tr> <th>MLFB SIMOREG CCP</th> <th>MLFB identification number (n570)</th> <th>r071 [V]</th> <th>No. of the associated characteristic diagram</th> </tr> </thead> <tbody> <tr> <td rowspan="2">6RA7085-6FC00-0</td> <td rowspan="2">250</td> <td>420</td> <td>1, 1A</td> </tr> <tr> <td>470</td> <td>2, 2A</td> </tr> <tr> <td rowspan="2">6RA7091-6FC00-0</td> <td rowspan="2">251</td> <td>420</td> <td>3, 3A</td> </tr> <tr> <td>470</td> <td>4, 4A</td> </tr> <tr> <td rowspan="2">6RA7095-6FC00-0</td> <td rowspan="2">252</td> <td>420</td> <td>5, 5A</td> </tr> <tr> <td>470</td> <td>6, 6A</td> </tr> <tr> <td rowspan="3">6RA7090-6KC00-0</td> <td rowspan="3">253</td> <td>520</td> <td>7.0, 7.0A</td> </tr> <tr> <td>600</td> <td>7, 7A</td> </tr> <tr> <td>720</td> <td>8, 8A</td> </tr> <tr> <td rowspan="3">6RA7095-6KC00-0</td> <td rowspan="3">254</td> <td>520</td> <td>9.0, 9.0A</td> </tr> <tr> <td>600</td> <td>9, 9A</td> </tr> <tr> <td>720</td> <td>10, 10A</td> </tr> </tbody> </table> <p>The appropriate voltage value is then found for the specified values for P111 and r072i002 in the characteristic diagram.</p> <p>An example for determining U578 for n570 = 6RA7091-6FC00-0 (identification number = 251) P101 = 460 V P111 = 0.23 mH r072i002 = 890.0 A</p> <p>In accordance with n570 and r071, characteristic diagram 4 (4A) must be used. As abscissa value, the next smaller grid value of 0.22 mH is used as approximation instead of P111 = 0.23 mH. For r072i002 = 890.0 A, a linear interpolation is made in the associated current range of 800 A to 900 A. The next larger ordinate grid value at 380 V is used as approximation. Thus, U578 = 380 V must be set.</p> <p>If the armature circuit inductivity specified with P111 exceeds the value range shown in the characteristic diagram, the determination must be made for the maximum shown value for P111.</p> <p>Depending on the values for P111 and r072i002, the required voltage value may lie outside the upper or lower limit shown in the characteristic diagram.</p> <p>The upper limit shown in the characteristic diagrams is true for a value for P351 = -20% of P078i001 (in accordance with the factory setting). The following upper limit is used for a value for P351 that differs from the factory setting:</p> $\text{Upper limit} = \frac{1.35 * P078.001 * \left(1 + \frac{P351}{100 \%}\right)}{1.073}$	MLFB SIMOREG CCP	MLFB identification number (n570)	r071 [V]	No. of the associated characteristic diagram	6RA7085-6FC00-0	250	420	1, 1A	470	2, 2A	6RA7091-6FC00-0	251	420	3, 3A	470	4, 4A	6RA7095-6FC00-0	252	420	5, 5A	470	6, 6A	6RA7090-6KC00-0	253	520	7.0, 7.0A	600	7, 7A	720	8, 8A	6RA7095-6KC00-0	254	520	9.0, 9.0A	600	9, 9A	720	10, 10A	145 to 830 [V] 1V	Ind: none FS=145 Type: O2	P052 = 3 P051 = 40 Online
MLFB SIMOREG CCP	MLFB identification number (n570)	r071 [V]	No. of the associated characteristic diagram																																							
6RA7085-6FC00-0	250	420	1, 1A																																							
		470	2, 2A																																							
6RA7091-6FC00-0	251	420	3, 3A																																							
		470	4, 4A																																							
6RA7095-6FC00-0	252	420	5, 5A																																							
		470	6, 6A																																							
6RA7090-6KC00-0	253	520	7.0, 7.0A																																							
		600	7, 7A																																							
		720	8, 8A																																							
6RA7095-6KC00-0	254	520	9.0, 9.0A																																							
		600	9, 9A																																							
		720	10, 10A																																							

PNU	Description	Value range [Unit] Steps	No. indices Factory setting Type	See Change (Access / Status)
	<p>The following cases can occur:</p> <p><u>Determined voltage value < 145 V</u> (lower limit in the characteristic diagram): Set U578 = 145 V.</p> <p>The successful extinguishing process by the SIMOREG CCP is always guaranteed, however, the short-term voltage loading (or instantaneous increase) of the motor that occurs for an extinguishing process is higher than necessary.</p> <p><u>The determined voltage value lies between the lower limit (145 V) and the upper limit:</u> The determined voltage value must be set at U578. The successful extinguishing process by the SIMOREG CCP is always guaranteed.</p> <p><u>Determined voltage value > upper limit:</u> The operation of the basic unit – SIMOREG CCP combination is not permitted. The successful extinguishing process by the SIMOREG CCP is not guaranteed. The manufacturer may have a solution for this problem.</p> <p><u>Note:</u> For the existing communication between the basic unit and SIMOREG CCP (P790=6), the setpoint specified by U578 in the SIMOREG CCP will be set by its operational firmware. If the actual line voltage is too low so that the setpoint cannot be attained, the basic unit signals this for operating states < 4.0 with the A032 warning and subsequently by the F032 fault (fault value 3) to indicate that the required charge voltage is not attained.</p> <p>If, after a successful commissioning, one of the relevant plant parameters changes, the correct setting for U578 must be checked and possibly changed.</p>			
U580 (2580)	<p>Control word for commutation monitoring [SW 2.1 and later]</p> <p>The commutation of the converter is constantly monitored. If a commutation failure is detected, fault message F030 is activated and the thyristor is quenched by the SIMOREG CCP (if installed). Detection of a commutation failure is based on three decision criteria. They can be individually activated/deactivated with this parameter for test purposes.</p> <p>0: None of the three decision criteria are evaluated 1: Decision criterion 1 (sufficient voltage time area for commutation) is evaluated 2: Decision criterion 2 (curvature of the current crest curve) is evaluated 4: Decision criterion 3 (maximum current actual value) is evaluated</p> <p>Setting instruction: Each decision criterion has a numeric code. If more than one decision criterion is to be evaluated, the sum of the relevant digits must be entered. If U806 is ≥ 2 (i.e. basic unit is a slave connected in parallel), decision criterion 1 is not evaluated irrespective of the setting of U580.</p>	0 to 7 1	Ind: none FS=7 Type: O2	P052 = 3 P051 = 40 Online
U581 (2581)	<p>Diagnostic memory for commutation monitoring [SW 2.1 and later]</p> <p>This memory is updated every time fault message F030 is activated. It provides the SIEMENS specialist with more detailed information about the cause of the commutation failure.</p>	0 to 65536 1	Ind: 68 Type: O2	P052 = 3

PNU	Description	Value range [Unit] Steps	No. indices Factory setting Type	See Change (Access / Status)
U582 (2582)	<p>Reaction of commutation monitor [SW 2.1 and later]</p> <p>This parameter allows the reaction of the commutation monitor to be programmed.</p> <p>1 Detection of a commutation failure or overcurrent results in immediate pulse blocking and generation of warning A030. The pulses are enabled again after approximately 20ms and warning A030 is reset.</p> <p>2 Detection of a commutation failure or overcurrent results in immediate pulse blocking and generation of fault message F030.</p> <p><u>Important:</u> The setting U582 = 1 is not allowed when the SIMOREG CCP is selected (P790 = 6)!</p>	1 to 2 1	Ind: none FS=2 Type: O2	P052 = 3 P051 = 40 Online
U583 (2583)	<p>Test command for the SIMOREG CCP [SW 2.1 and later]</p> <p>This parameter can be used for test purposes to issue an extinguishing command to the SIMOREG CCP.</p> <p>0 No extinguishing command is specified 1 An extinguishing command is specified in MI 2 An extinguishing command is specified in MII</p> <p>This parameter automatically resets itself to the value 0 after a single issuance of an extinguishing command to the SIMOREG CCP!</p> <p><u>Note:</u> If the test command is given during operation (i.e. in modes I and II), the basic unit determines the necessary torque direction for selection of the correct test command. In the operating state 'torque direction 0 (--)', the test command is given in torque direction I.</p>	0 to 2 1	Ind: none FS = 0 Type: O2	P052 = 3 P051 = 40 Online

7.2.2 Connectors

SIMOREG CCP states			
K0574	Status of the SIMOREG CCP Meaning of the individual bits: refer to parameter n574	1 \triangleq 1	
K0575	I2t value of voltage limiting chopper 1 of the SIMOREG CCP	16384 \triangleq 100%	
K0576	I2t value of voltage limiting chopper 2 of the SIMOREG CCP	16384 \triangleq 100%	

K0577	<p>Low byte: command for the SIMOREG CCP</p> <ul style="list-style-type: none"> Bit0 = Fire the extinguishing thyristors Bit1 = Line voltage (armature) lies within the tolerance range Bit2 = This SIMOREG CCP is connected to the parallel-switching master Bit3 = Main contactor ON Bit4 = Torque direction 1 active Bit5 = Torque direction 2 active Bit6 = always 1 Bit7 = always 1 <p>High byte: diagnostic information for monitoring the blocking voltage time integral</p> <p>The monitoring of the blocking voltage time integral leads to the initiation of the SIMOREG CCP (and for A030 or F030 with fault value 1) when bit 8 OR bit 9 = 1, AND ALL other bits = 1 (i.e. the condition is satisfied)</p> <ul style="list-style-type: none"> Bit8 = Torque direction I AND EMF <= +5% (i.e. energy recovery) Bit9 = Torque direction II AND EMF >= -5% (i.e. energy recovery) Bit10 = Control angle > 90° (i.e. energy recovery) Bit11 = No pulse return Bit12 = Armature current is flowing (The I = 0 signal is present for a maximum of 0.6 ms) Bit13 = The blocking voltage time integral is too small (< 50% of the theoretical value) Bit14 = Decision criterion 1 will be evaluated (see U580) Bit15 = "No parallel-switching operation" or "parallel-switching master" (U800 = 0 OR U800 = 1 OR [U800 = 2 AND U806 > 10]) <p>Note: The bits 8 and 9 are always current. For all other bits: the bits after the first bit with the value 0 are invalid!</p>	1 \triangleq 1	
--------------	------------------------------------------------------------------------------------------------------------------------------------------------------------------------------------------------------------------------------------------------------------------------------------------------------------------------------------------------------------------------------------------------------------------------------------------------------------------------------------------------------------------------------------------------------------------------------------------------------------------------------------------------------------------------------------------------------------------------------------------------------------------------------------------------------------------------------------------------------------------------------------------------------------------------------------------------------------------------------------------------------------------------------------------------------------------------------------------------------------------------------------------------------------------------------------------------------------------------------------------------------------------------------------------------------------------------------------------------------------------------------------------------------------------------------------------------------------------------------------------------------------------------------------------------------------------------------------------------------------------------------------------------------------------------------------	------------------	--

7.2.3 Faults

F030	<p>Commutation failure or overcurrent has occurred or test command has been issued via U583</p> <p>(active in all operating states)</p> <p>Possible error causes</p> <ul style="list-style-type: none"> ◆ Mains voltage dip in regenerative feedback mode ◆ Current control loop not optimized <p>Fault value: r047 Index 002 to 016:</p>	
1	The blocking voltage time area for the commutating thyristor pair was too small	for i001= 1 to 3 and 5, i002 to i006 are valid for i001= 4, i002 to i015 is invalid
2	The current crest curve breaks upwards	i002 Delay angle (K0100) in case of error
3	The maximum current value was higher than 250% of the actual rated device current according to r072i002	i003 Actual EMF (K0287) in case of error i004 Trigger circuitry diagnostics (K0989) in case of error i005 Actual field current (K0265) in case of error i006 Number of pulses (K0105) in case of error
4	A paralleled SIMOREG DC-MASTER has detected a commutation failure or overcurrent	
5	test command has been issued via U583	

F032	SIMOREG CCP not ready	
	(active in operating states of < o4.0)	
	Possible error causes	
	<ul style="list-style-type: none"> • No connection or cable break at X172 (G-SST2) • No connection or cable break at X165 (paralleling interface master) in a parallel connection • No connection or cable break at X29_PAR or X30_PAR (extinction-pulse interface) in a parallel connection • Hardware defective in charging circuit of extinguishing capacitors • Blown fuse in the line-side or motor-side armature circuit • Blown fuse in the precharging circuit for the chopper capacitors • Required cooling phase for chopper resistors still in progress • MLFB (order number) data of the SIMOREG CCP (n570, n571, n572) are invalid or nonexistent 	
	Fault value:	r047 Index 002 to 016:
1	No voltage at U, V, W terminals of SIMOREG CCP	for i001= 1 to 12, i002 to i006 are valid
2	Voltage at C-D on CCP does not match voltage at C-D on SIMOREG DC-MASTER	for i001= 20, only i002 is valid
3	Surge absorbing capacitors of SIMOREG CCP have not reached setpoint voltage	i002 SIMOREG CCP status (K0574) in case of error
4	Paralleling interface cable is not connected to SIMOREG CCP assigned to paralleling master	i003 I2t value of chopper 1 (K0575) in case of error
5	No connection between SIMOREG DC-MASTER and SIMOREG CCP via G-SST2 serial interface (r799.i001 is not incremented)	i004 I2t value of chopper 2 (K0576) in case of error
6	No connection between parallel SIMOREG CCPs	i005 Actual armature voltage (r038) in case of error in 0.1 V for i005 > 32767: $U_{\text{ARMATURE}} [\text{V}] = (65536 - r047i005)/10$
7	Contents of technical data memory on SIMOREG CCP (MLFB, rated values, serial number) invalid	i006 effective time until the fault initiation in 20 ms
11	I2t value (n575) of voltage chopper 1 is too high (> 100%)	
12	I2t value (n576) of voltage chopper 2 is too high (> 50%)	
20	Chopper capacitors not completely precharged in time set with P089 or the condition in accordance with fault value 5 is satisfied	

7.2.4 Alarms

A030	<p>Commutation failure or overcurrent has occurred (active in operating states of – –, I, II)</p> <p>Possible error causes</p> <ul style="list-style-type: none"> • Mains voltage dip in regenerative feedback mode • Current control loop not optimized
A032	<p>SIMOREG CCP not ready (active in operating states of < o4.0)</p> <p>Possible causes</p> <ul style="list-style-type: none"> • No voltage at U, V, W terminals of SIMOREG CCP • Voltage at C-D on CCP does not match voltage at C-D on SIMOREG DC-MASTER • Surge absorbing capacitors of SIMOREG CCP have not reached setpoint voltage • Paralleling interface cable is not connected to SIMOREG CCP assigned to paralleling master • No connection between SIMOREG DC-MASTER and SIMOREG CCP via G-SST2 serial interface • No connection between parallel SIMIOREG CCPs • Contents of technical data memory on SIMOREG CCP (MLFB, rated values, serial number) invalid • I2t value of voltage chopper 1 is too high (> 100%) • I2t value of voltage chopper 2 is too high (> 50%)

7.3 Commissioning steps

Note:

The parameter values to be set for commissioning of the SIMOREG CCP must be determined graphically with the help of the characteristic diagrams (appendix).

As an alternative, an existing commissioning script can be used for the DriveMonitor (script file `ccp.ssc` and database file `simoreg-ccp-mlfb.xml`).

If the basic device contains software V 3.1 or higher, commissioning of the SIMOREG CCP can be carried out by selecting P051=30 (automatic setting of parameters for SIMOREG CCP). This optimization run must be carried out after commissioning step 4. In this case, commissioning steps 3, 5 and 6 are not carried out. If fault F050 (optimization run cannot be carried out) occurs during this optimization run, the description for the respective fault value (r047.001) indicates possible causes.

1. Interconnect SIMOREG CCP in accordance with the connection suggestion in Chapter 6.
2. Set P790=6 (communication with the CCP).
The correct communication will be indicated optically by an LED on the Power Interface module C98043-A7046:
LED flashes slowly (<1Hz) communication with the SIMOREG CCP correct,
LED flashes fast (approx. 3Hz) no communication with the SIMOREG CCP
3. Determination of the setting value for parameter U577 (factory setting = 1600)
Required parameter values:
r070...MLFB (identification number) of the SIMOREG DC-MASTER
n570...MLFB (identification number) of the SIMOREG CCP

⇒ Determination of the setting value in accordance with the parameter description for U577
4. Commissioning of the basic unit as specified in Chapter 7 of the SIMOREG DC-MASTER operating instructions.
The commissioning must have been completed correctly. This means that the optimization runs as specified in commissioning step 8 must also be performed.
In particular, the optimization run for the precontrol and the current controller for the armature and the field (P051=25) must be performed, because this process determines the armature circuit inductivity and the value of P111 is needed for a subsequent SIMOREG CCP commissioning.

Warning:

P351 must not be parameterized with a larger negative value than the factory setting, otherwise the addition of a line contactor (or circuit-breaker) causes an excessive charging current impulse in the chopper capacitors. This can damage the CCP power semiconductors.

Note:

The chopper capacitors are charged using an internal precharging circuit. When the undervoltage threshold determined by P351 is reached, the line contactor (or the circuit-breaker) will be applied. This bridges the precharging circuit.

Note:

If error F030 occurs during the commissioning of the basic unit (in particular, for the optimization runs), the commutation monitoring for the commissioning must be deactivated (U580=0). The commutation monitoring must be reactivated after the successful completion of the commissioning (U580=7).

Warning:

If an existing drive system has been upgraded with a SIMOREG CCP, the optimization run for the precontrol and the current controller for the armature and the field (P051=25) must be performed. The value for P111 determined in this optimization run is needed for the commissioning of the SIMOREG CCP. Because the P111 parameter can be changed during a manual optimization, the current value for P111 with P051=25 should be noted prior to performing the optimization run and set again only after the SIMOREG CCP commissioning has been completed.

5. Determination of the maximum energy in the armature circuit for the extinguishing process

Required parameter values:

n570	MLFB (order number) of the SIMOREG CCP
r072i002	Actual converter rated DC current (armature) [A]
P101	Rated motor armature voltage [V] ^{1.)}
P111	Armature circuit inductance [mH]

and a characteristic diagram as specified in the following table:

MLFB SIMOREG CCP	MLFB- identification number	P101 [V] ^{1.)}	No. of the associated characteristic diagram ^{2.)}
6RA7085-6FC00-0	250	420	11
		470	12
6RA7091-6FC00-0	251	420	11
		470	12
6RA7095-6FC00-0	252	420	13
6RA7090-6KC00-0	253	520	14.0
		600	14
		720	15
6RA7095-6KC00-0	254	520	16.0
		600	16
		720	17

1.) Rated direct voltage according to rating plate of the motor (the values are typical ratings for SIEMENS direct-current motors from the DA12 product catalog)

2) The characteristic diagrams are contained in the appendix of these operating instructions

If the graphically determined value lies under the W_{\max} limit line, the energy removal in the armature circuit is guaranteed by the SIMOREG CCP

6. Determination of the setting value for parameter U578 (factory setting = 145)

Required parameter values:

n570	MLFB (order number) of the SIMOREG CCP
r071	Converter rated supply voltage (armature) [V]
r072i002	Actual converter rated DC current (armature) [A]
P078i001	Rated input voltage converter armature [V]
P101	Rated motor armature voltage [V]
P111	Armature circuit inductance [mH]
P351	Threshold for undervoltage trip [%].

⇒ Determination of the setting value in accordance with the parameter description for U578

The SIMOREG CCP is now operational.

8 Maintenance



WARNING

Hazardous voltage are present in this electrical equipment during operation.

Non-observance of the safety instructions can result in death, severe personal injury or substantial property damage.

When carrying out maintenance work on this device, please read all safety instructions included in this section and attached to the product itself.



- Maintenance work on the converter may be carried out only by qualified personnel who are thoroughly familiar with all safety notices in this manual and with the installation, operating and maintenance instructions.
- Before carrying out visual checks and maintenance work, ensure that the AC power supply is disconnected and locked out and that the converter is grounded. Before the AC supply is disconnected, both converters and motors are at hazardous voltage levels. Even when the converter contactor is open, hazardous voltages are still present.
- The snubber capacitors in the SIMOREG converter might still be carrying hazardous voltage after isolation from the supply. For this reason, the converter must not be opened for at least two minutes after switch-off.
- Before starting work, make sure all devices are safely isolated from supply (see Section 1).

Only spare parts authorized by the manufacturer may be used.

The converter must be thoroughly protected against the ingress of dirt so as to prevent voltage flashovers and this irreparable damage. Dust and foreign bodies, and especially contamination drawn in through the cooling air flow, must be carefully removed at regular intervals depending on the degree of pollution, but at least once every 12 months. The converter must be cleaned with dry, compressed air, max. 1 bar, or with a vacuum cleaner.

8.1 Procedure for updating software

1 Read out and write down the contents of all modified parameters.
(also note software version in n560)

Note:
The parameter set can be transferred to a PC or programming device by means of DriveMonitor (see also Section 15 of the operating instructions of SIMOREG DC-MASTER 6RA70).

2 Switch off electronics power supply of the SIMOREG CCP.

3 Connect one COM port on the PC to connector X300 on the SIMOREG CCP.

Cable order number: 6SX7005-0AB00
(see also Section 15 of the operating instructions of SIMOREG DC-MASTER 6RA70).

4 Switch on electronics power supply AND press down the S1 key on the Power Interface Module C98043-A7046 at the same time
⇒ The SIMOREG CCP enters the programming mode (the yellow indicator LED on the SIMOREG CCP remains dark)

Note:
A timer with approximately 2 minute expiration duration now starts running in the SIMOREG CCP. If, in the meantime, the update is not started from the PC, the SIMOREG CCP returns to the normal operational state. If the software update is restarted, the procedure must be repeated starting at step 2.

5 Start the `LOAD_CCP.exe` load program on the PC and click the "Open file" button to select the required data file (`7046Axxx.hex`). Click the "Open" button to start the load operation (duration approx. 10 seconds).

Note:
In the Properties dialog for a link to `LOAD_CCP.exe`, a parameter of the form COMx can be transferred, where 1 or 2 must be specified for x (default: COM1)

6 After a successful software update, the SIMOREG CCP automatically enters the normal operating mode (the yellow indicator LED on the SIMOREG CCP flashes slowly when communication with the basic unit exists).

Note:
If the electronics power supply is switched off during the software update, the procedure must be repeated starting at step 4.

7 Check the new software version at n560.

8 END

8.2 Replacement of components

8.2.1 Replacement of PCBs



WARNING

PCBs may be replaced only by properly qualified personnel.

PCBs must not be removed or inserted when the power supply is connected.

Non-observance of the safety instructions can result in death, severe personal injury or substantial property damage.



CAUTION

PCBs contains electrostatically sensitive devices. Before touching a PCB, the person carrying out the work must himself be electrostatically discharged. The simplest way of doing this is to touch an electrically conductive earthed object, e.g. socket outlet earth contact.

Replacement of chopper unit

- Remove the C98043-A7047 Limiter Board
- Remove the screws (1)
- Remove the screws (2)
- Replace the module(s)

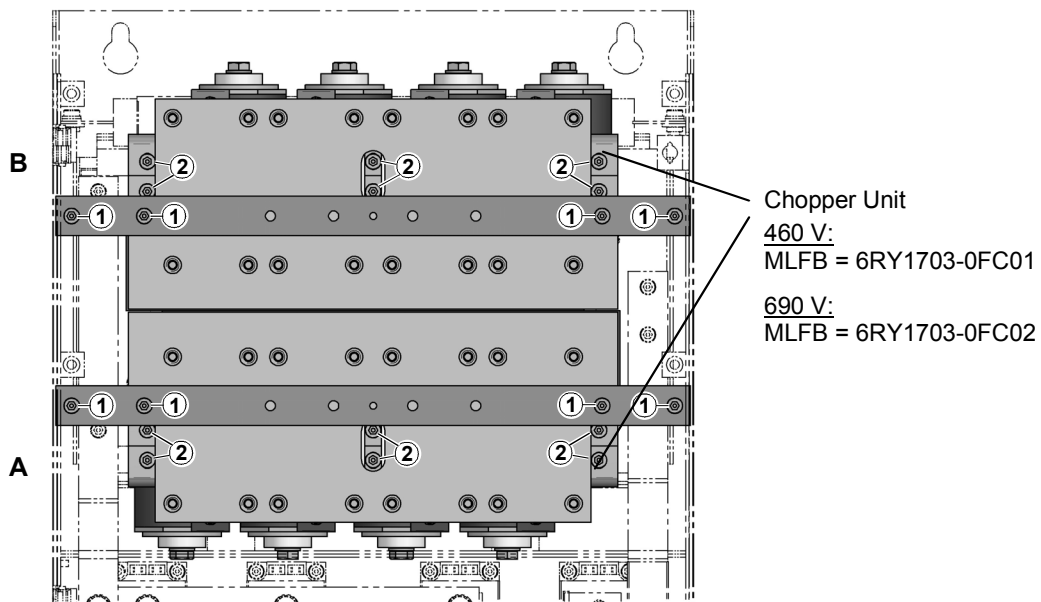

Note:

Only one chopper unit is present for the 6RA7085-6FC00-0, 6RA7091-6FC00-0 and 6RA7090-6KC00-0 devices (position A).

Replacement of the PCBs

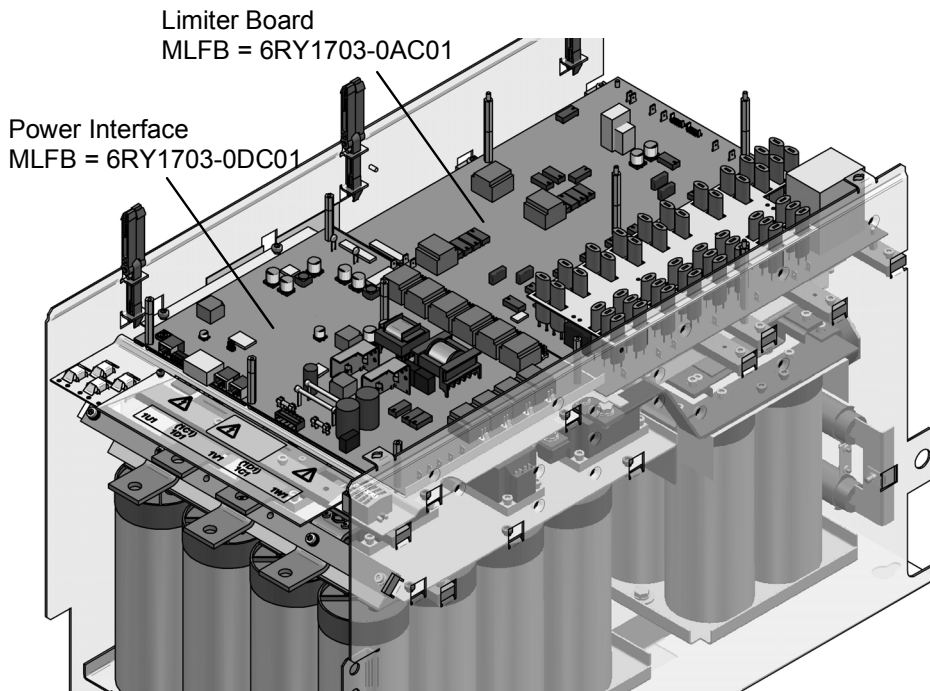

8.2.2 Replacement of diodes, thyristor and IGBT modules

The modules are mounted by means of self-tapping screws. To fix the modules always used screws with a metric thread of the same length as the original screws and fixing elements (washer and spring lock washer). When screwing the modules to the busbars and boards, also use screws with a metric thread and the same length as the original screws and fixing elements (washer and spring lock washer).

Module design

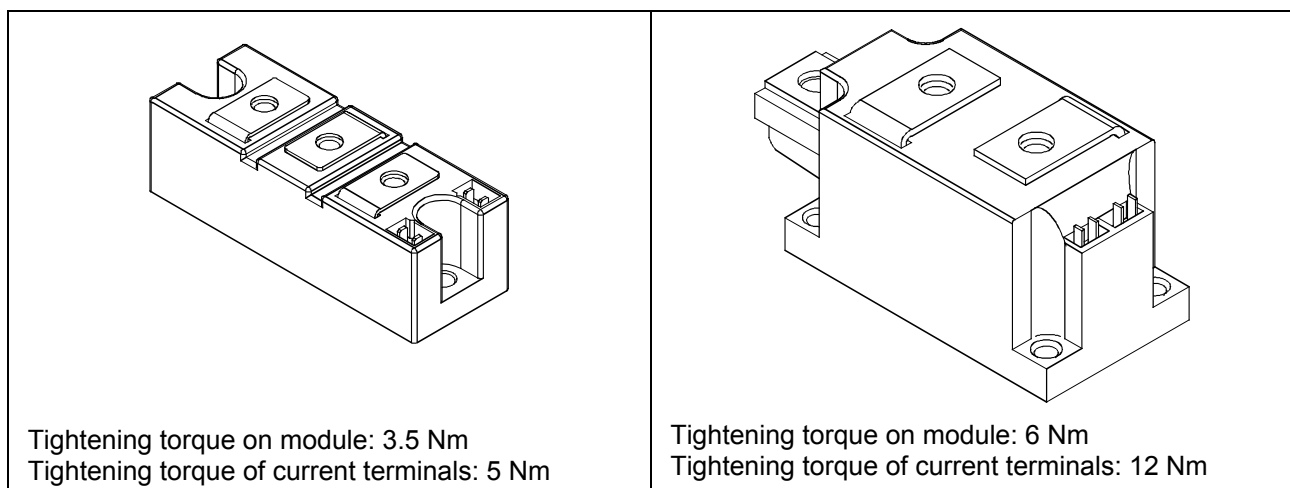

IGBT Type SKM 500 GA 174 DS

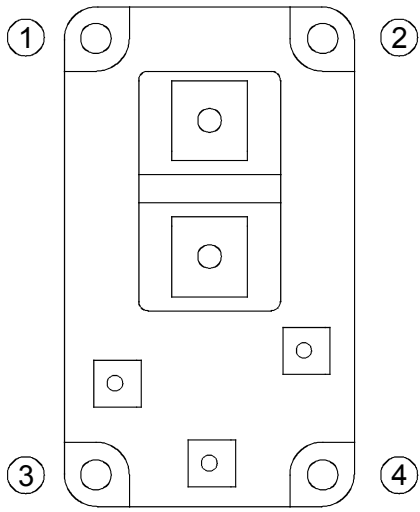
 <p>Tightening torque on module: 5 Nm Tightening torque of current terminals: 5 Nm</p>	<p>NOTICE !</p> <p>All four IGBT modules always have to be replaced.</p> <p>It is only permissible to use the original types of IGBT!</p> <p>The sequence to be followed when screwing on the IGBT modules is shown in the illustration and must be observed under all circumstances.</p>
-----------------------------------------------------------------------------------------------------------------------------------------------------------------------------	--------------------------------------------------------------------------------------------------------------------------------------------------------------------------------------------------------------------------------------------------------------------------------------------------

9 Servicing

NOTE

If you contact us with a query, please specify the following converter data:

- Converter order number and serial number
- Software version
- Hardware version of the board C98043-A7046 (Power Interface)
(screen printing on component side)

Siemens supplies thoroughly tried and tested products and systems of the highest quality. To ensure maximum availability of our products and systems in your plant, we offer extensive after-sales services and support.

For further information about our services and your regional Siemens contacts, please go to our Internet website:

http://www.siemens.de/automation/csi_en/service

9.1 Technical Support

You can obtain technical assistance with our products, systems and solutions from our Technical Support service. Whether you have a simple query, or need help in solving a more difficult, complex task, our Central Technical Support specialists will be pleased to advise you. Our Central Technical Support service is available in English and German.

Internet: <http://www.siemens.com/automation/support-request>

Time zone Europe and Africa:	7:00 to 17:00 (CET) Tel.: +49 180 5050 222 Fax: +49 180 5050 223 mailto:ad.support@siemens.com
Time zone America:	8:00 to 17:00 (local time: Eastern Standard Time) Tel.: +1 423 262 2522 24 Hour Hotline: +1 800 333 7421 Fax: +1 423 262 2200 mailto:solutions.support@sea.siemens.com
Time zone Asia / Australia:	7:30 to 17:30 (local time: Beijing) Tel.: +86 1064 757575 Fax: +86 1064 747474 mailto:adsupport.asia@siemens.com

9.2 Repairs

If you wish to have a part or unit repaired, please call or write to your regional Siemens contact for repairs.

9.3 On-site servicing

Qualified specialists can offer an on-site repair and maintenance service to increase the availability of your plant. Repair and/or maintenance support can be charged according to time and cost or provided within the scope of a service contract at a flat rate. Services charged on a time/cost basis will be available within the normal working hours of the relevant region subject to an appropriate call-out period.

For on-site servicing, please call your regional Siemens contact.

9.4 Spare parts

Equipment identifier	Designation Type	Dimensions LxWxH (mm)	Weight (kg)	Order No. (MLFB)	Used in 6RA70..
C98043-A7046	PCB Power-Interface SIMOREG CCP	360x260x42	0.8	6RY1703-0DC01	.85-6FC00-0 .91-6FC00-0 .90-6KC00-0 .95-6FC00-0 .95-6KC00-0
C98043-A7047	PCB Limiter board SIMOREG CCP	375x360x68	1	6RY1703-0AC01	.85-6FC00-0 .91-6FC00-0 .90-6KC00-0 .95-6FC00-0 .95-6KC00-0
V100.1	Chopper unit 460V	310x110x210	3	6RY1703-0FC01	.85-6FC00-0 .91-6FC00-0
V100.1, V100.2	Chopper unit 460V	310x110x210	3	6RY1703-0FC01	.95-6FC00-0
V100.1	Chopper unit 690V	310x110x210	3	6RY1703-0FC02	.90-6KC00-0
V100.1, V100.2	Chopper unit 690V	310x110x210	3	6RY1703-0FC02	.95-6KC00-0
V41+V44, V42+V45, V43+V46, V47, V48	Diode module SKKD162/18	94x30x34	0.165	6RY1700-0BA06	.85-6FC00-0 .91-6FC00-0
V41+V44, V42+V45, V43+V46, V47, V48	Diode module SKKD162/22	94x30x34	0.165	6RY1700-0BA07	.90-6KC00-0
V41+V44, V42+V45, V43+V46, V47, V48	Diode module DD261N22	115x52x50	0.8	6RY1700-0BA08	.95-6FC00-0 .95-6KC00-0
V31+34, V32+33, V35+38, V36+37, V39, V40	Thyristor module SKKT162/18	94x30x34	0.165	6SY7010-0AA73	.85-6FC00-0 .91-6FC00-0
V31+34, V32+33, V35+38, V36+37, V39, V40	Thyristor module MCC161-22io1	94x30x34	0.125	6SY7010-0AA74	.90-6KC00-0
V31+34, V32+33, V35+38, V36+37, V39, V40	Thyristor module MCC224-22io1	115x52x50	0.75	6SY7010-0AA75	.95-6KC00-0
V31+34, V32+33, V35+38, V36+37, V39, V40	Thyristor module MCC312-18io1	115x52x50	0.75	6SY7010-0AA22	.95-6FC00-0
F1, F2	Fuses in the power interface C98043-A7046	20x5	0.002	6RY1702-0BA00	.85-6FC00-0 .91-6FC00-0 .90-6KC00-0 .95-6FC00-0 .95-6KC00-0

10 Environmental compatibility

Environmental aspects of development

Due to the use of highly integrated components, the number of parts has been kept to a minimum. This results in the highly efficient use of energy in production.

Particular importance has been attached to reducing the volume, mass and diversity of metal and plastic parts.

Front components:	PC + ABS ABS	Cycoloy Novodur	GE-Plastics Bayer
Plastic components in converter:	PC PA 6.6 SE1-GFN1	Lexan 141-R Noryl	
Insulation:	PC (FR) fl	Makrolon or Lexan	
Rating plate:	Polyester membrane		

Materials free of pollutants are used for all important parts. No flame-retardants containing halogen or insulating materials containing silicon are used.

Environmental compatibility was an important criterion in the selection of supplied parts.

Environmental aspects of production

Most supplied parts are shipped in reusable packaging. The packaging material itself is recyclable, consisting mainly of cardboard.

With the exception of the converter housing, surface coating materials have not been applied.

The production process is free of emissions.

Environmental aspects of disposal

The unit features screw and snap-on connections that can be separated easily to dismantle it into recyclable mechanical components.

The printed circuit boards can be disposed of by thermal processing. The percentage of components containing dangerous substances is low.

11 Appendix

Characteristic diagrams for determining parameter U578

< Untergrenze > = lower limit
 < Obergrenze > = upper limit

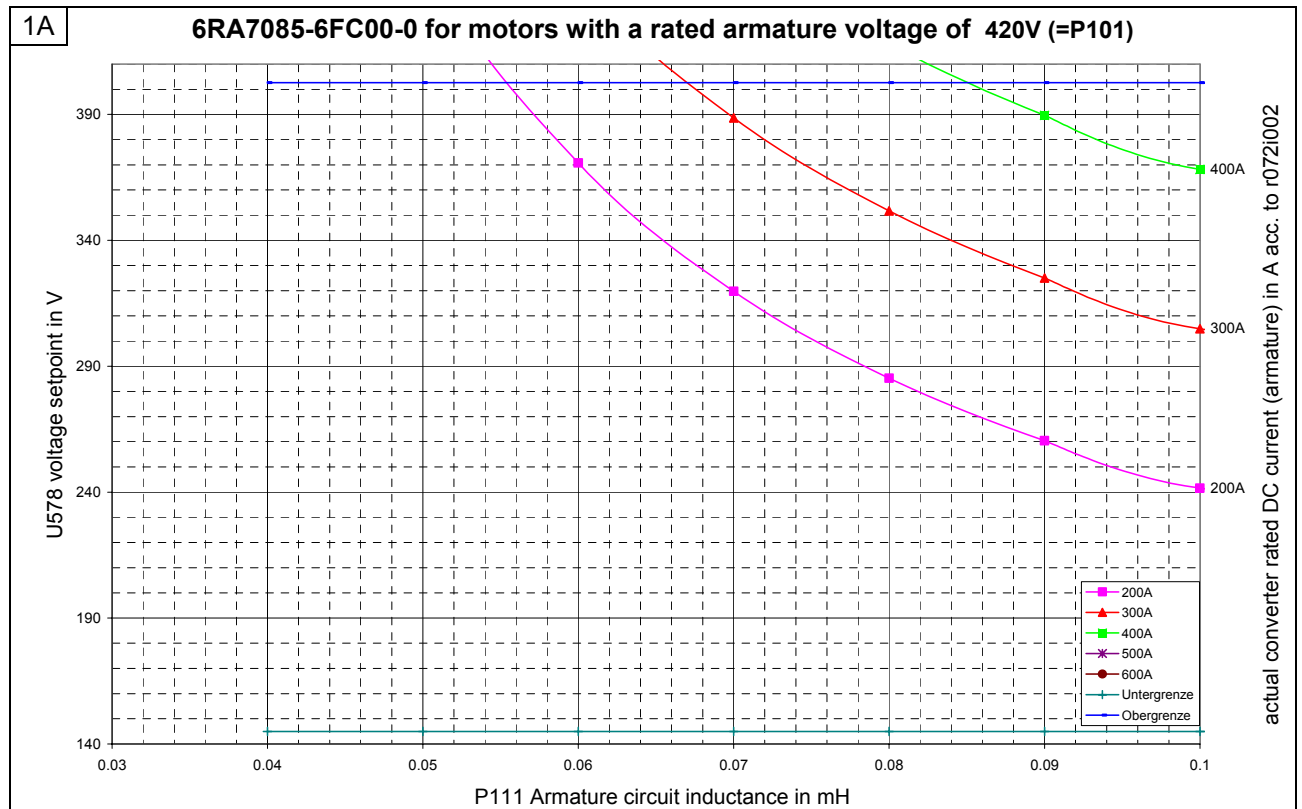
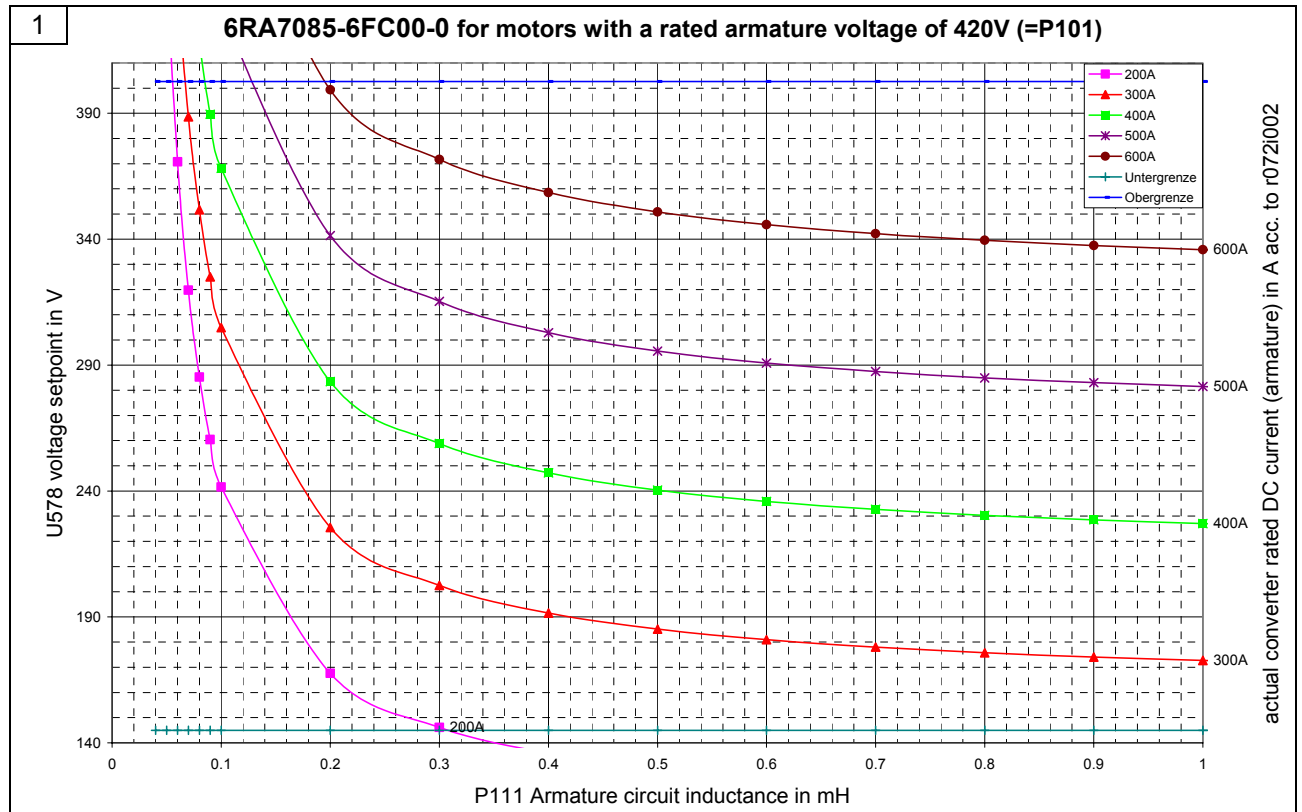

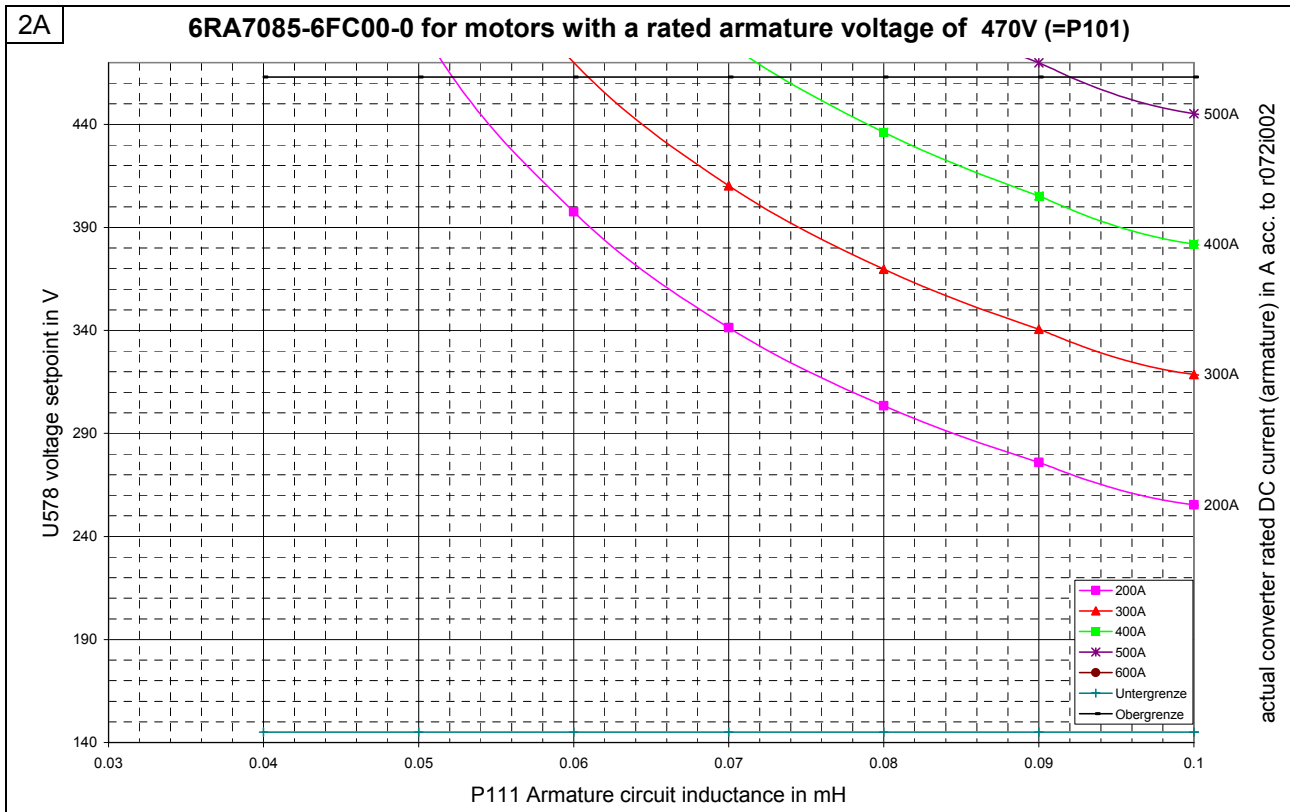
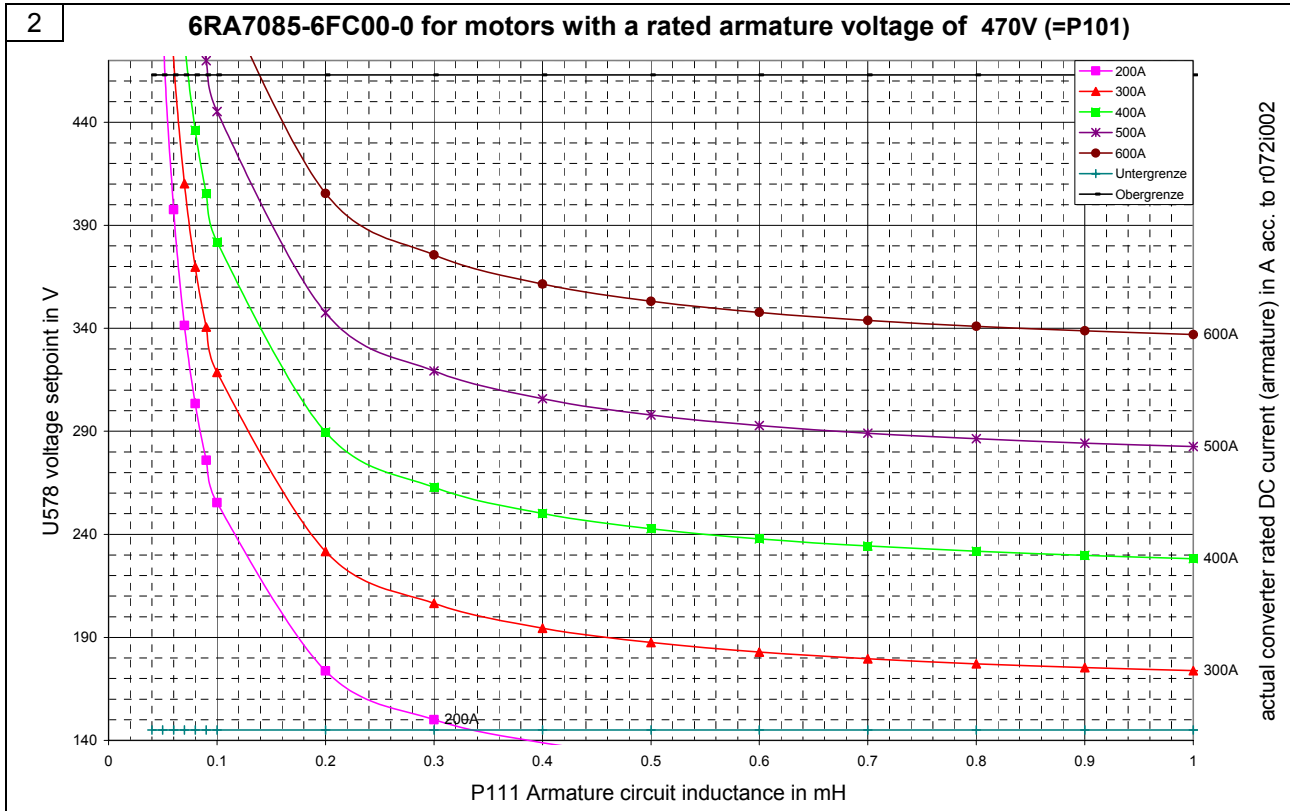

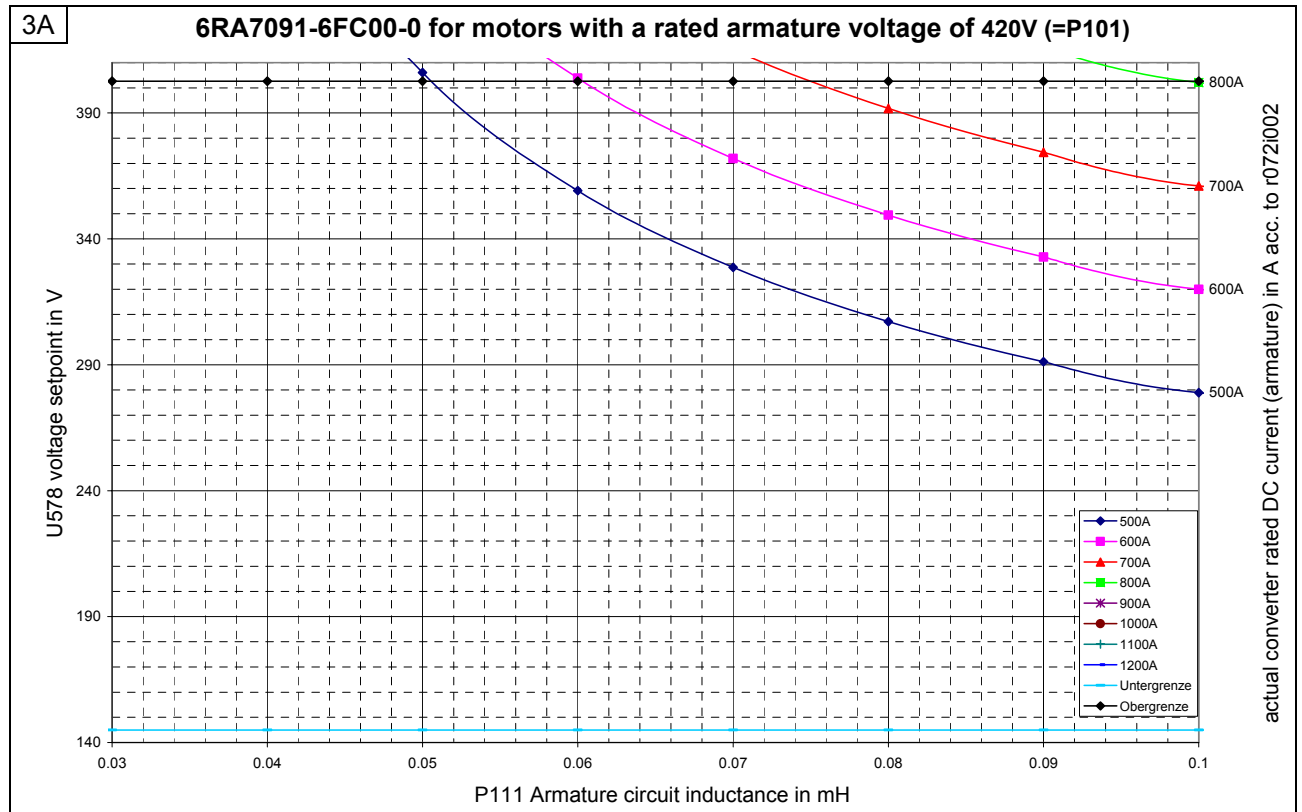
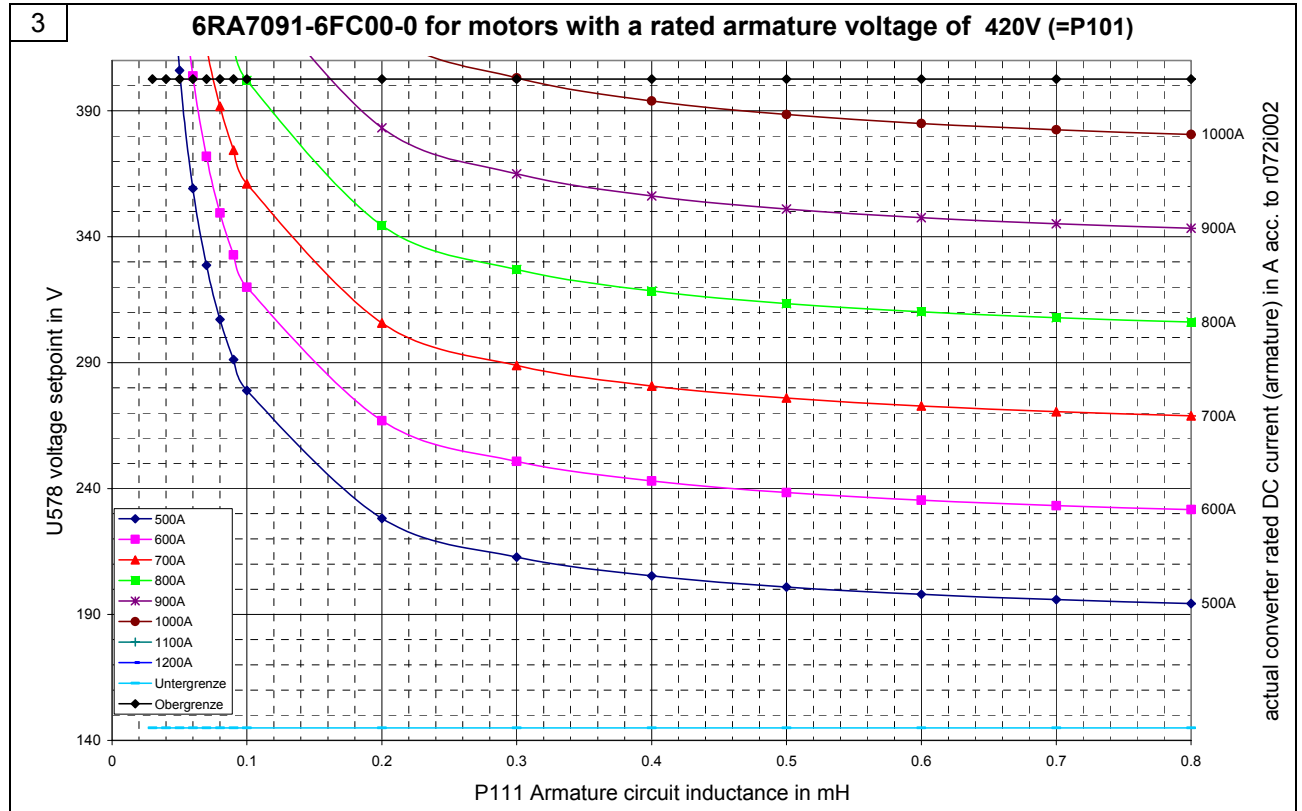

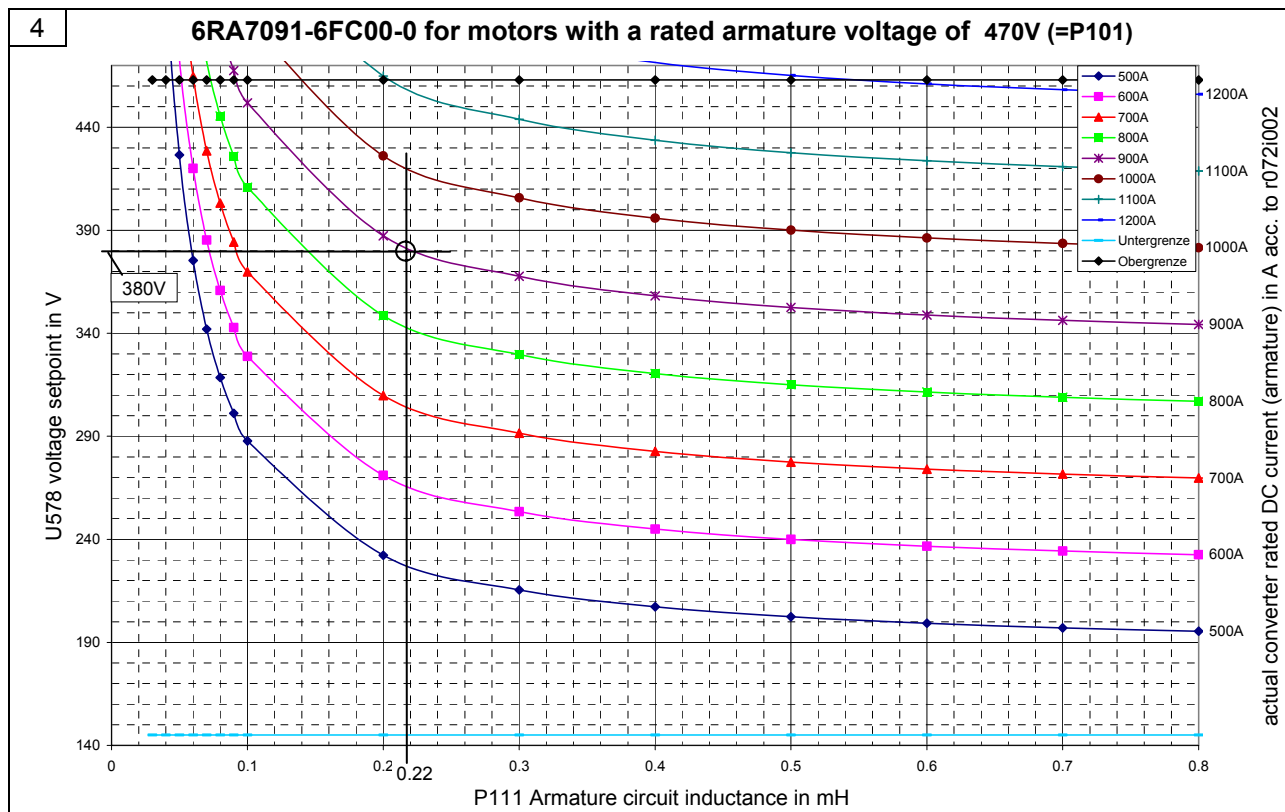

Note: The shown values refer to the example in the description for parameter U578

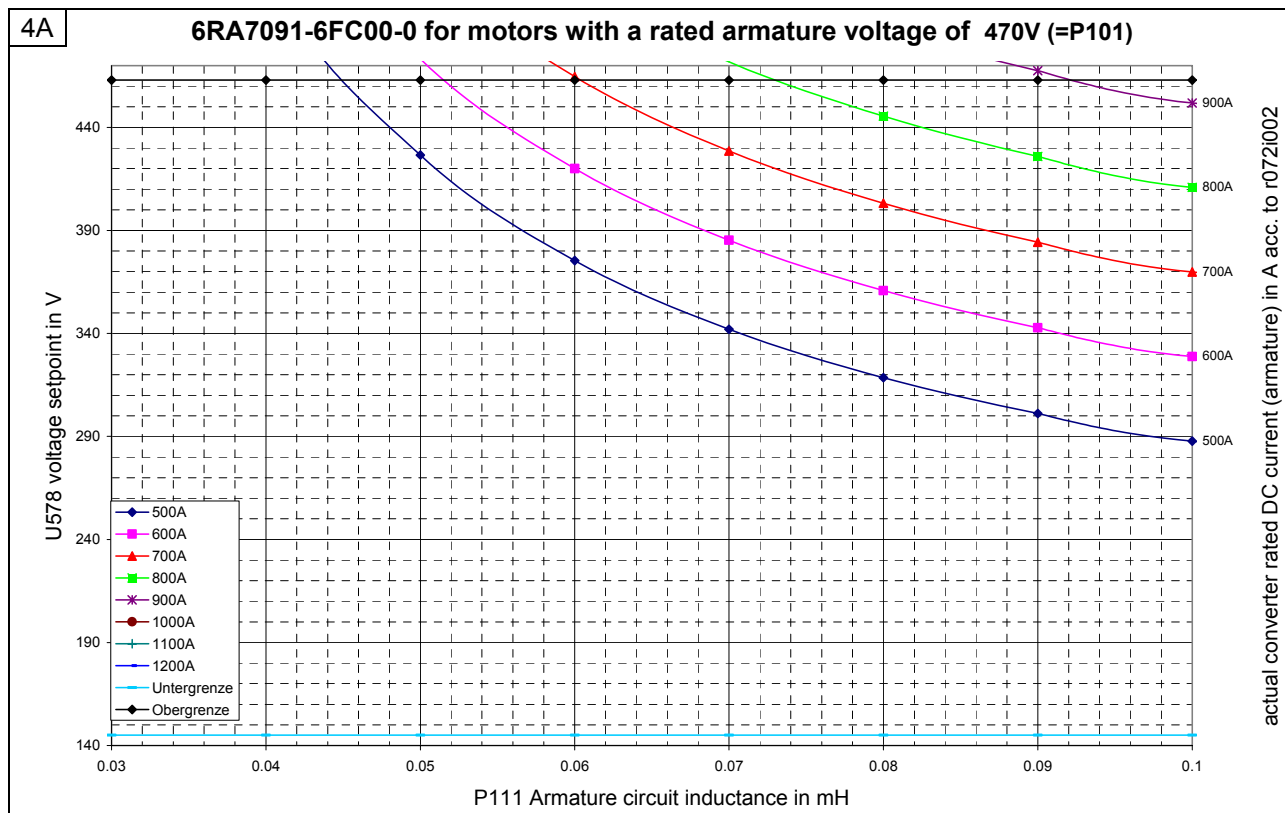

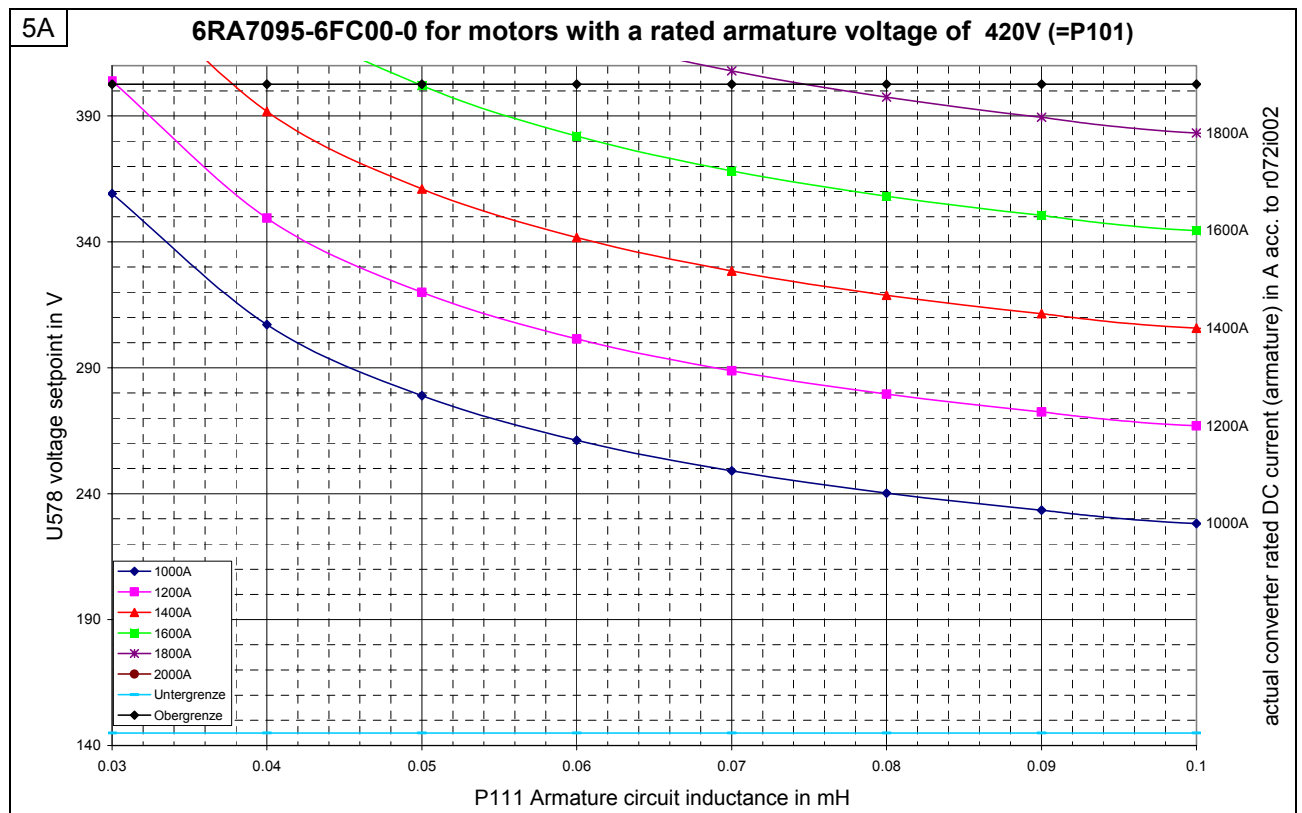
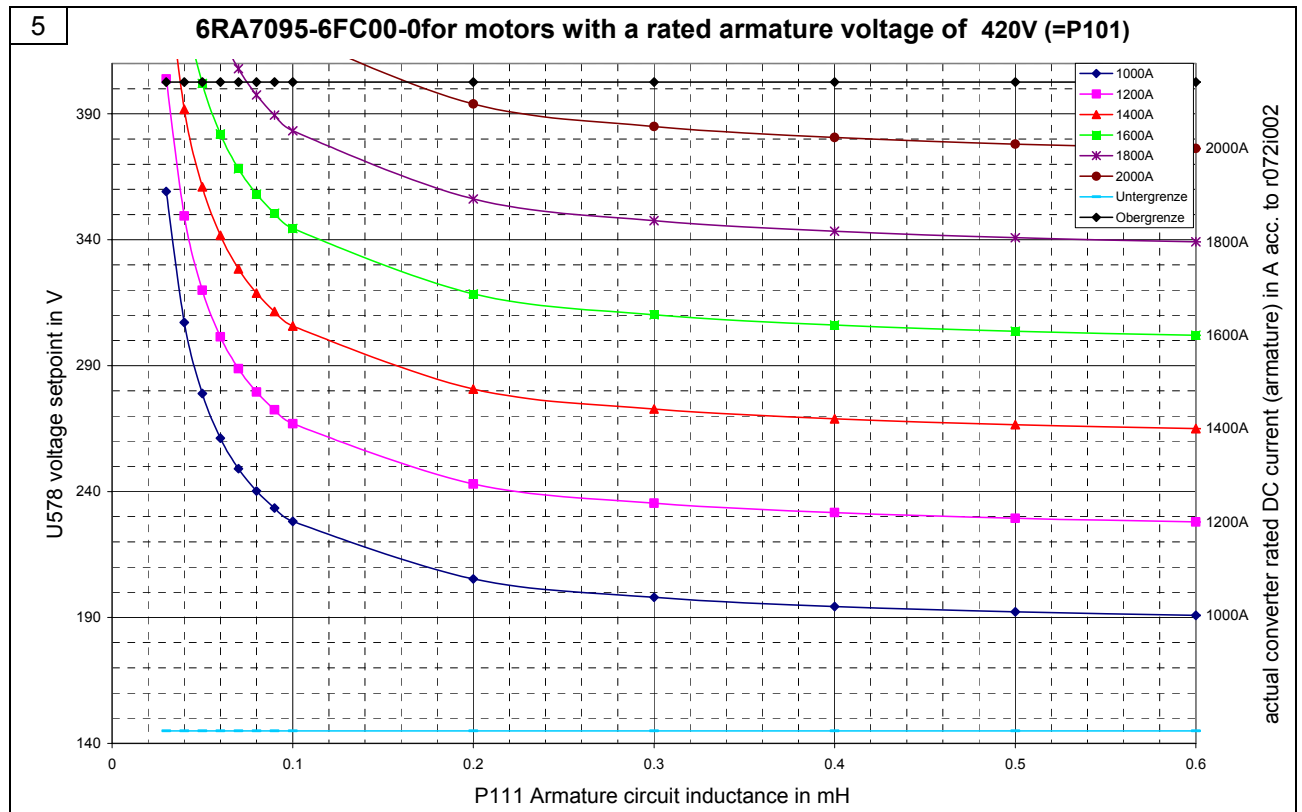

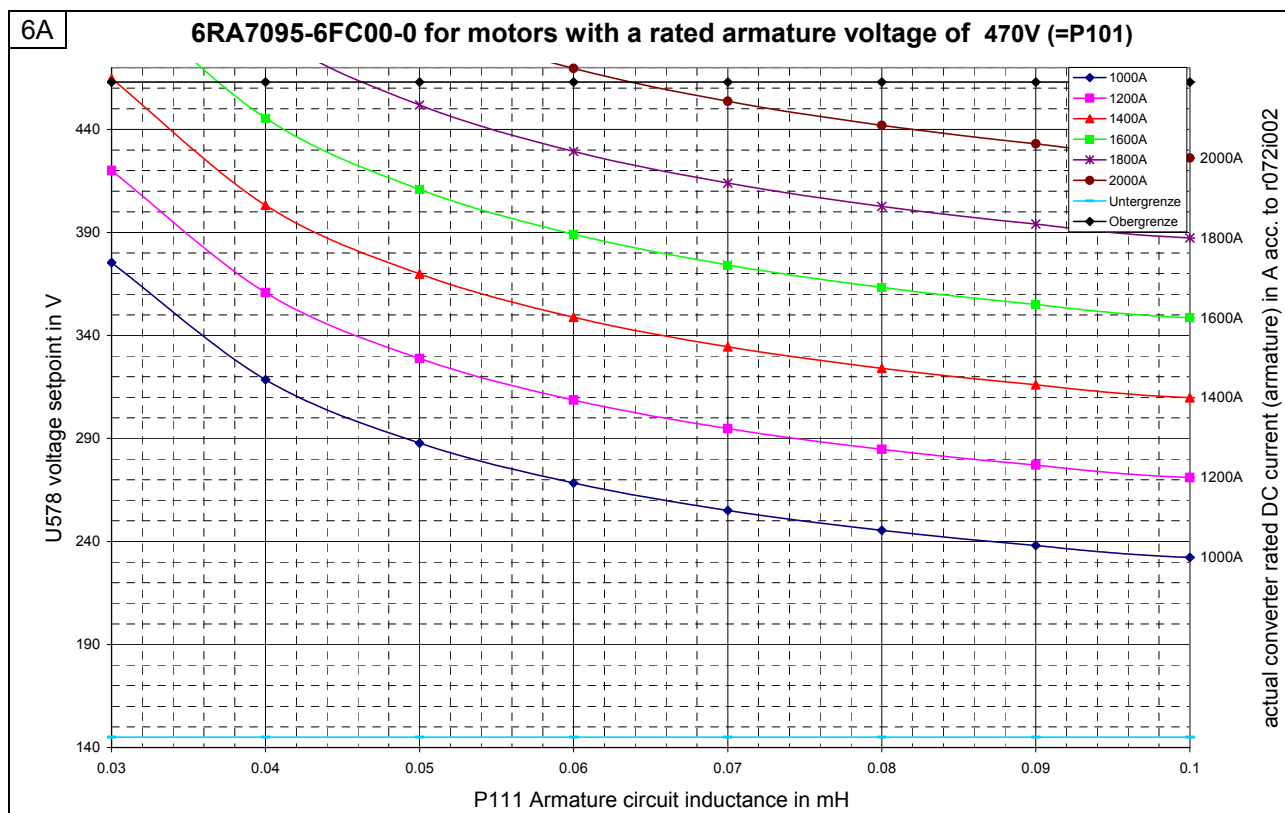
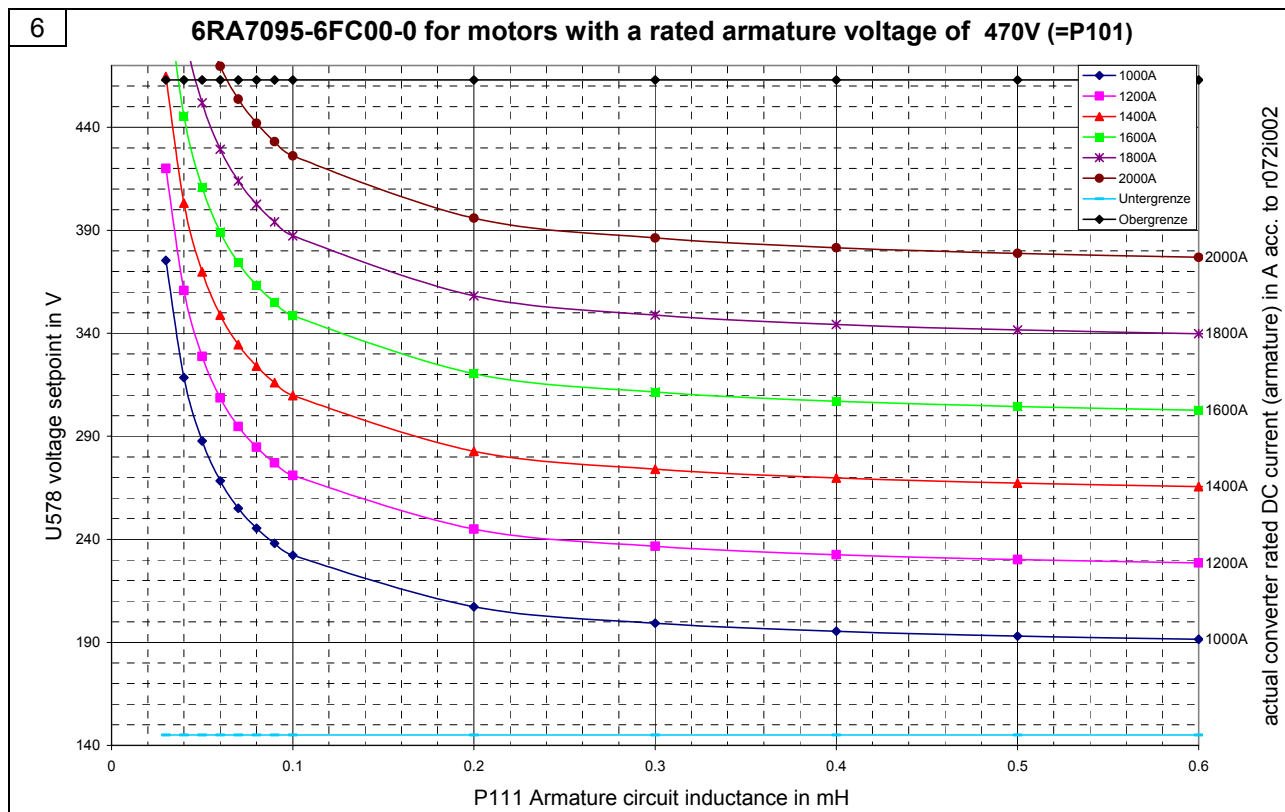

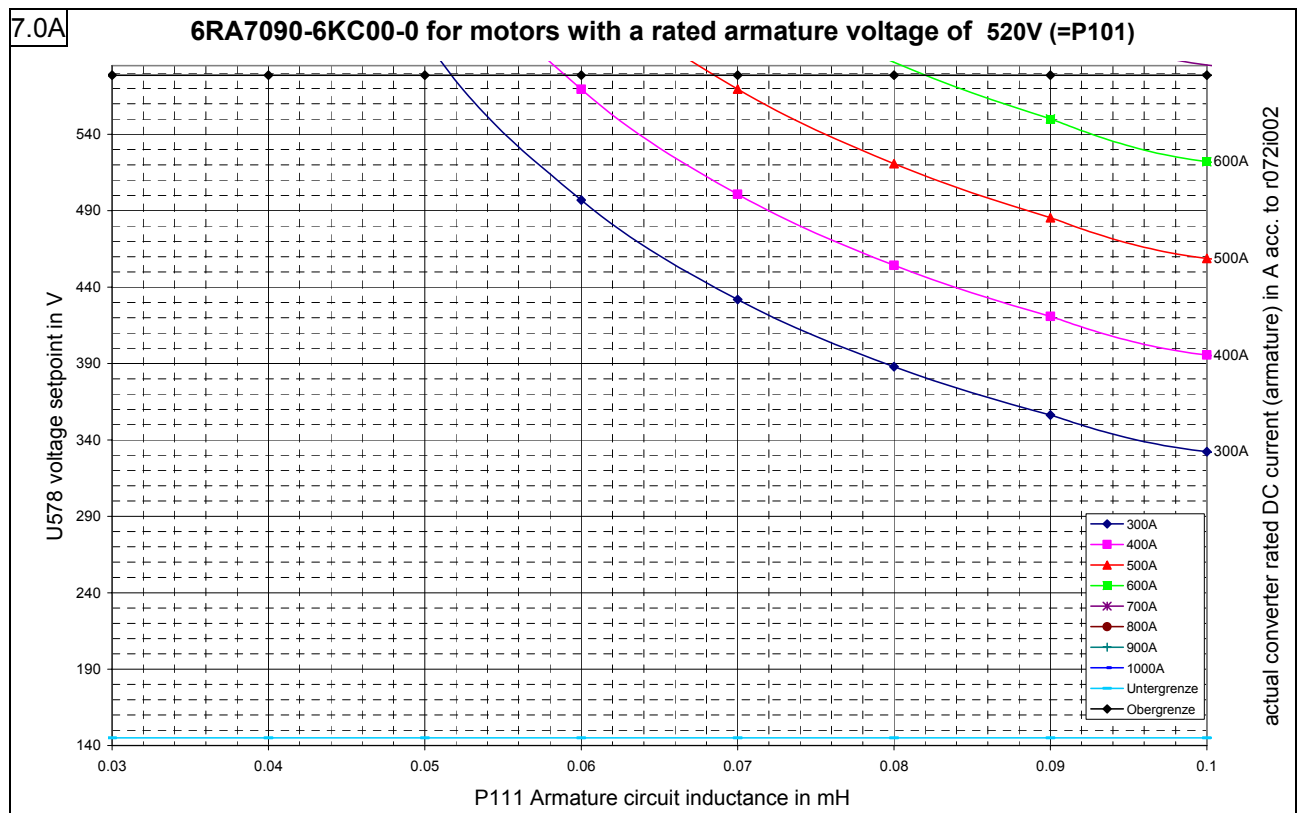
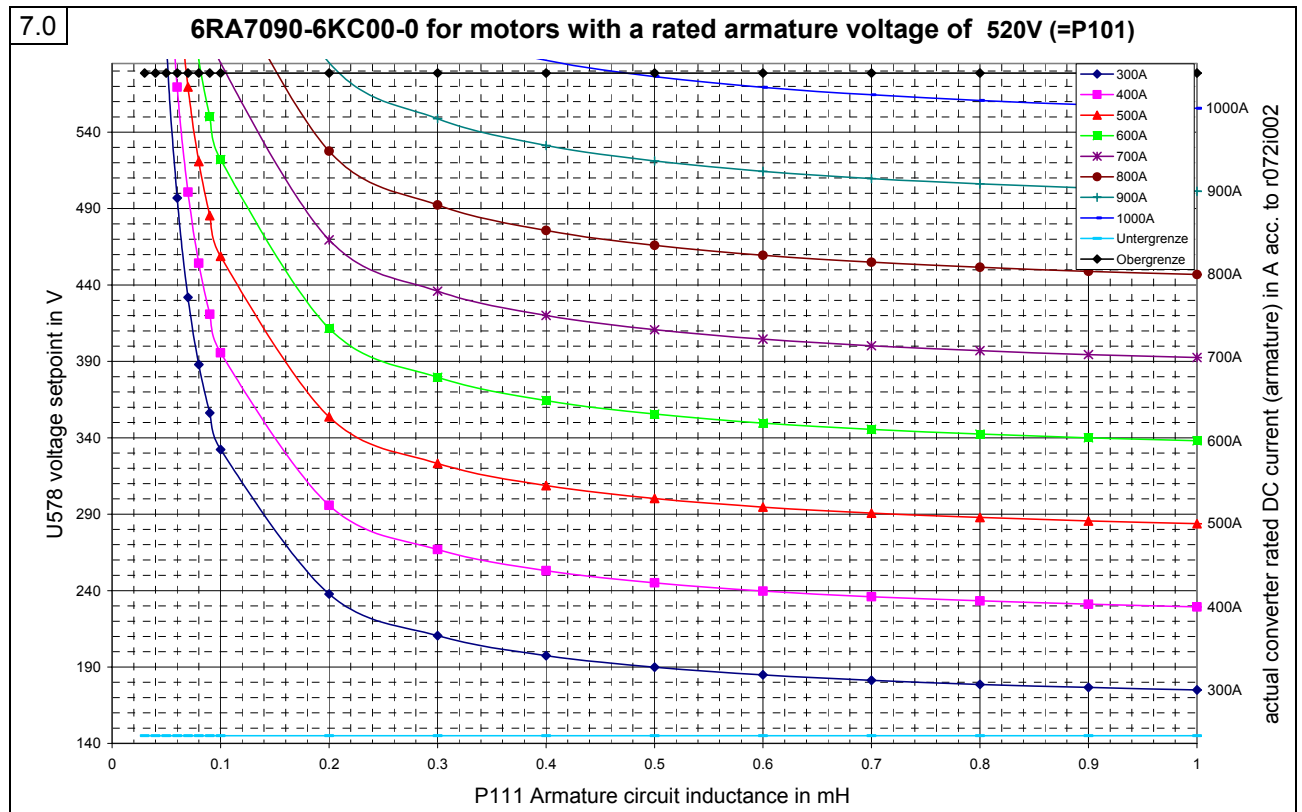

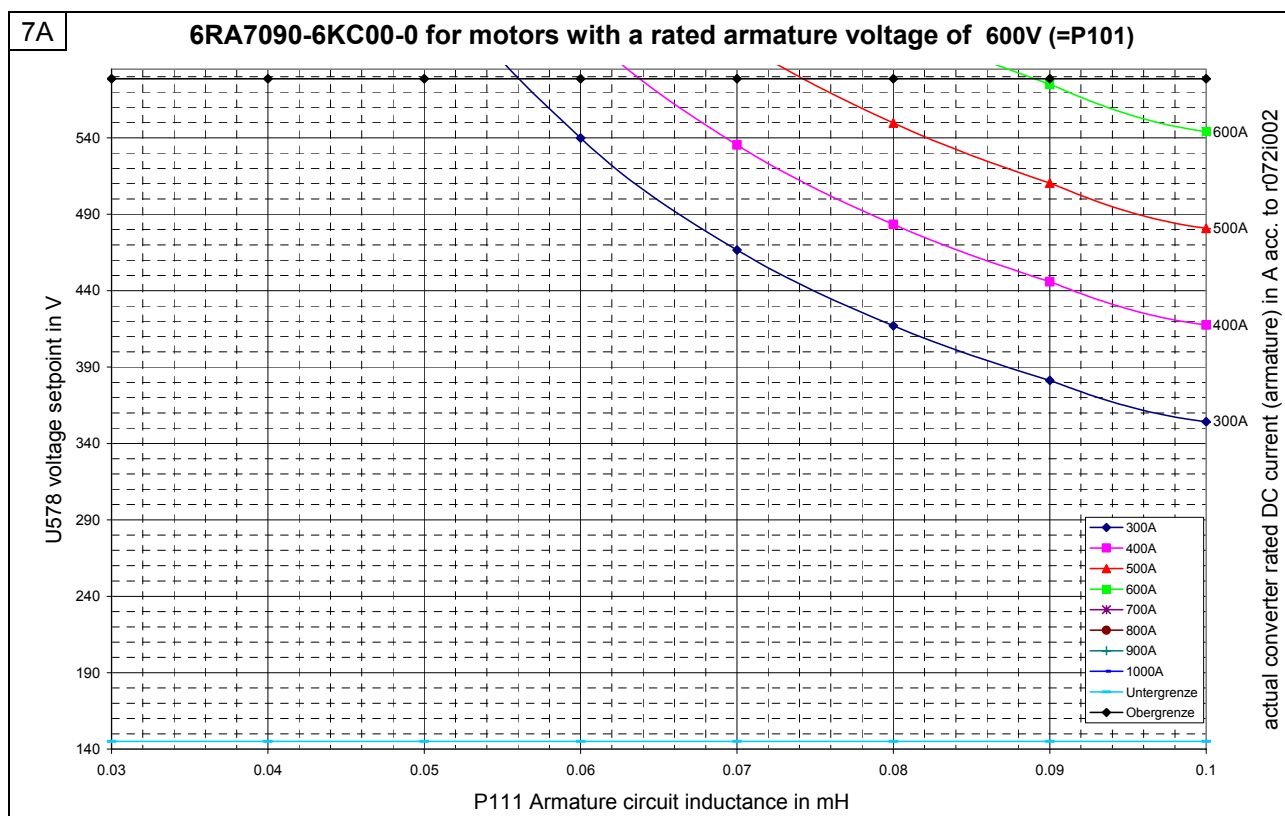
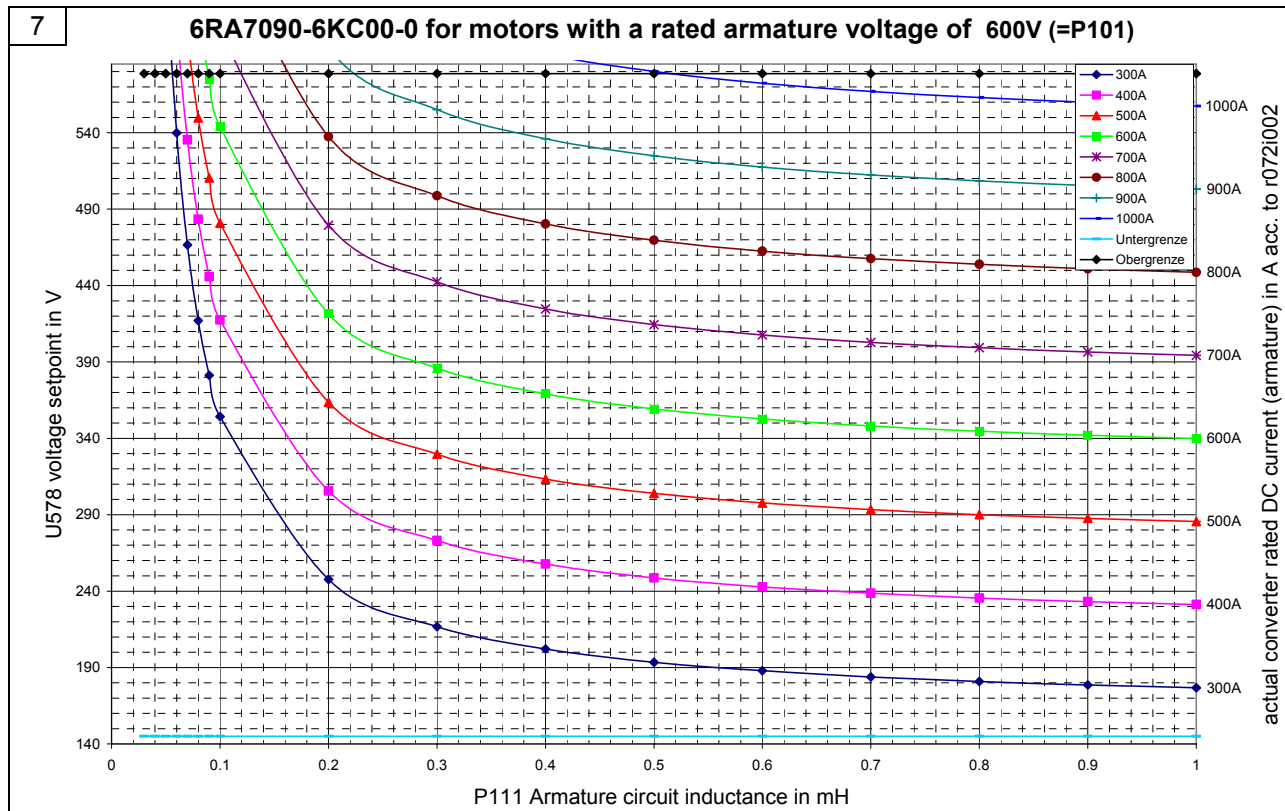

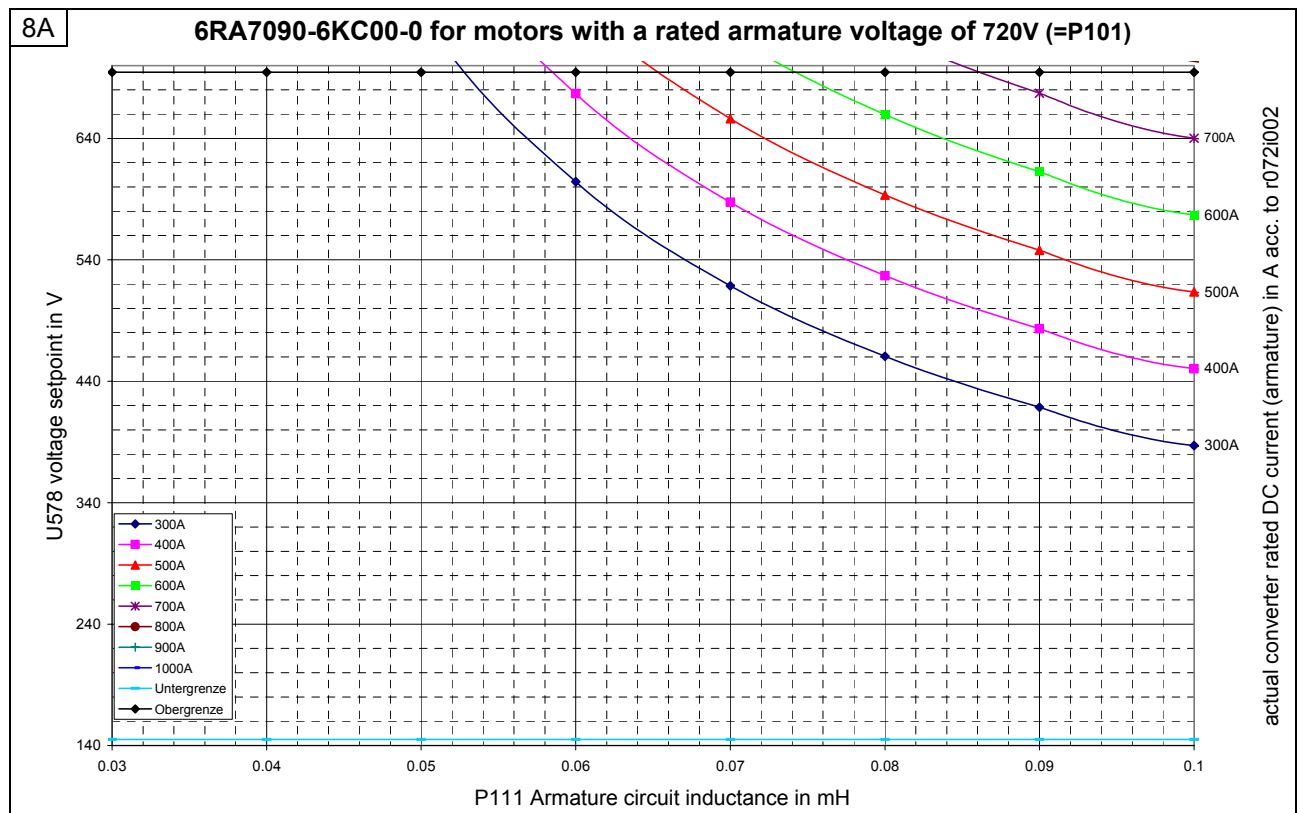
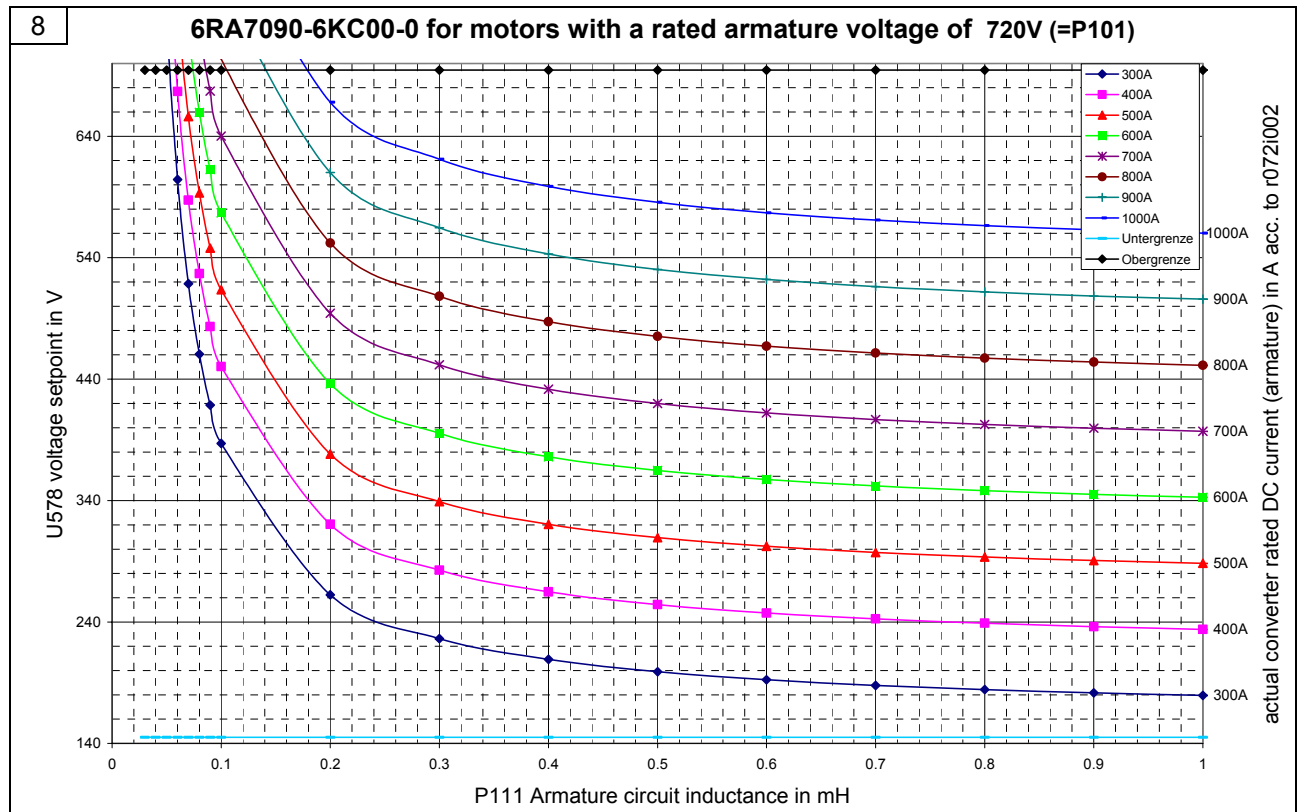

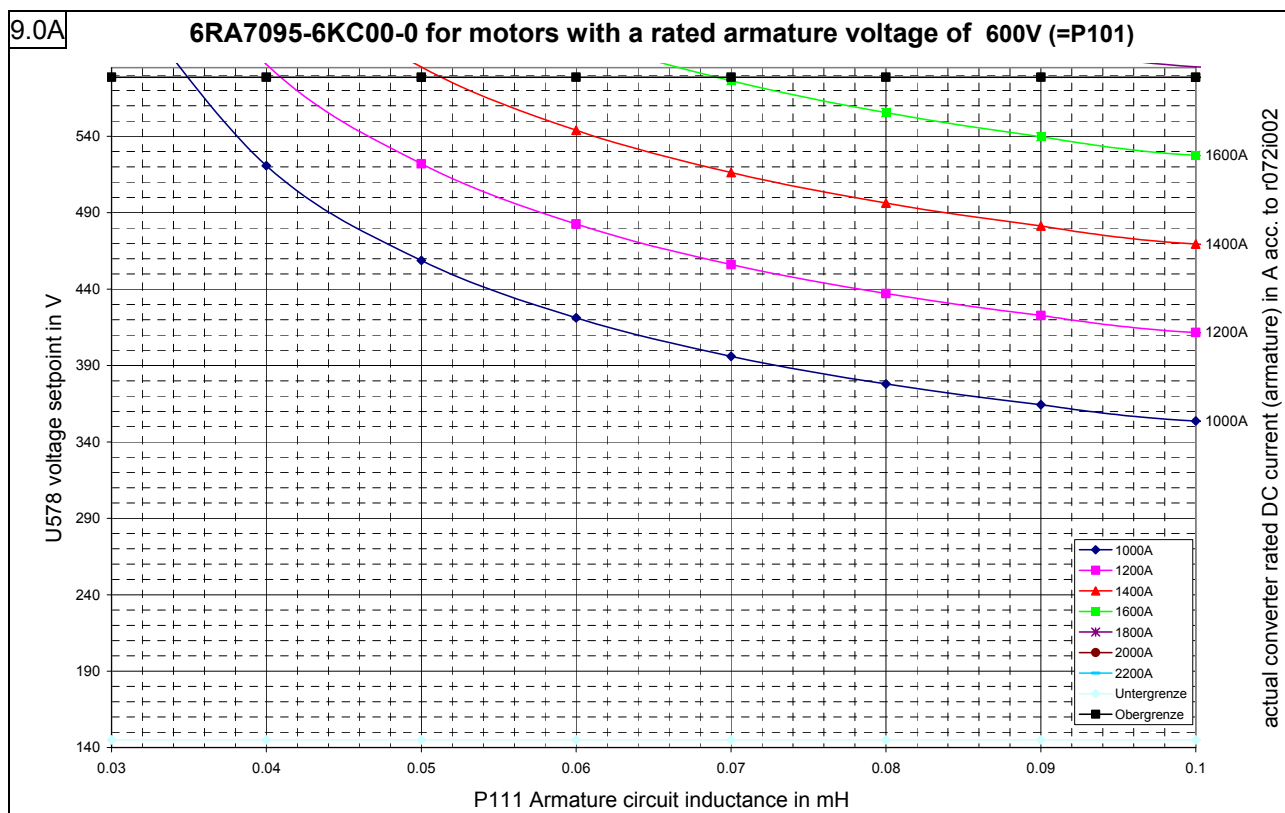
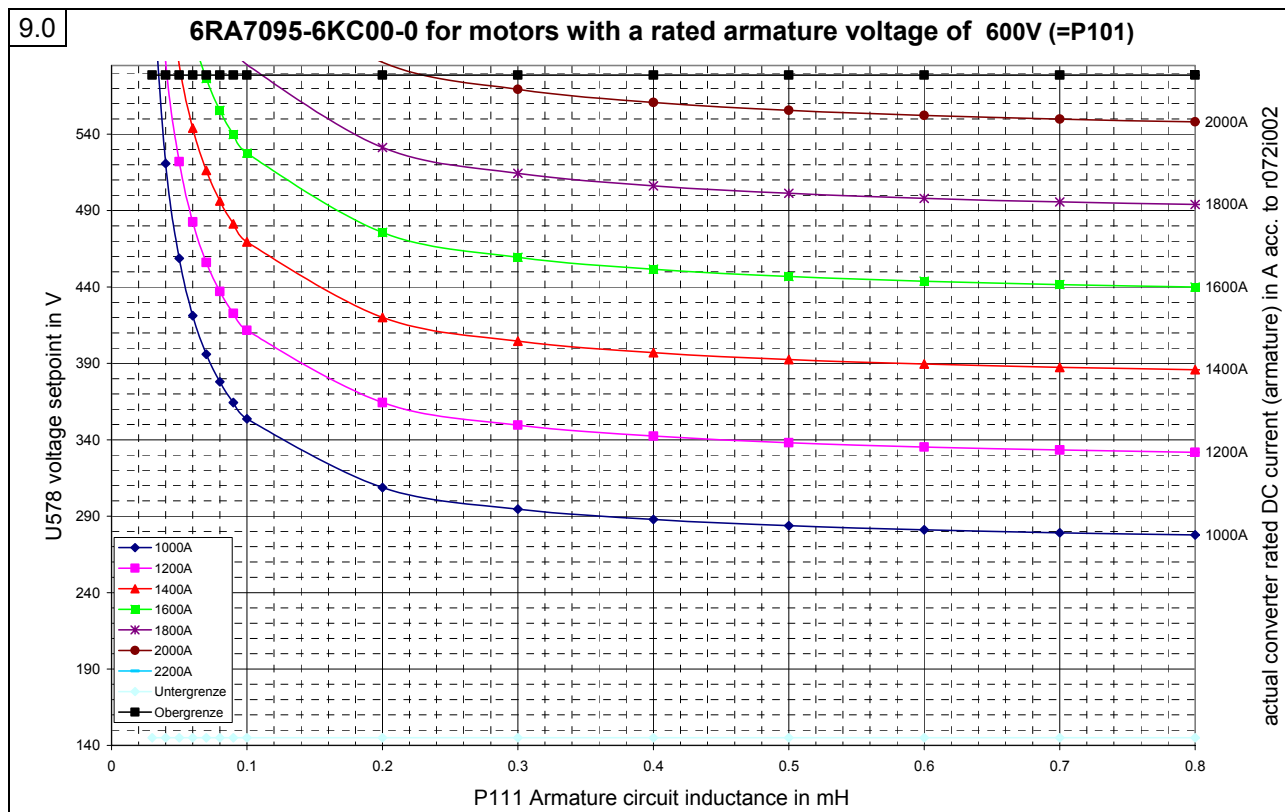

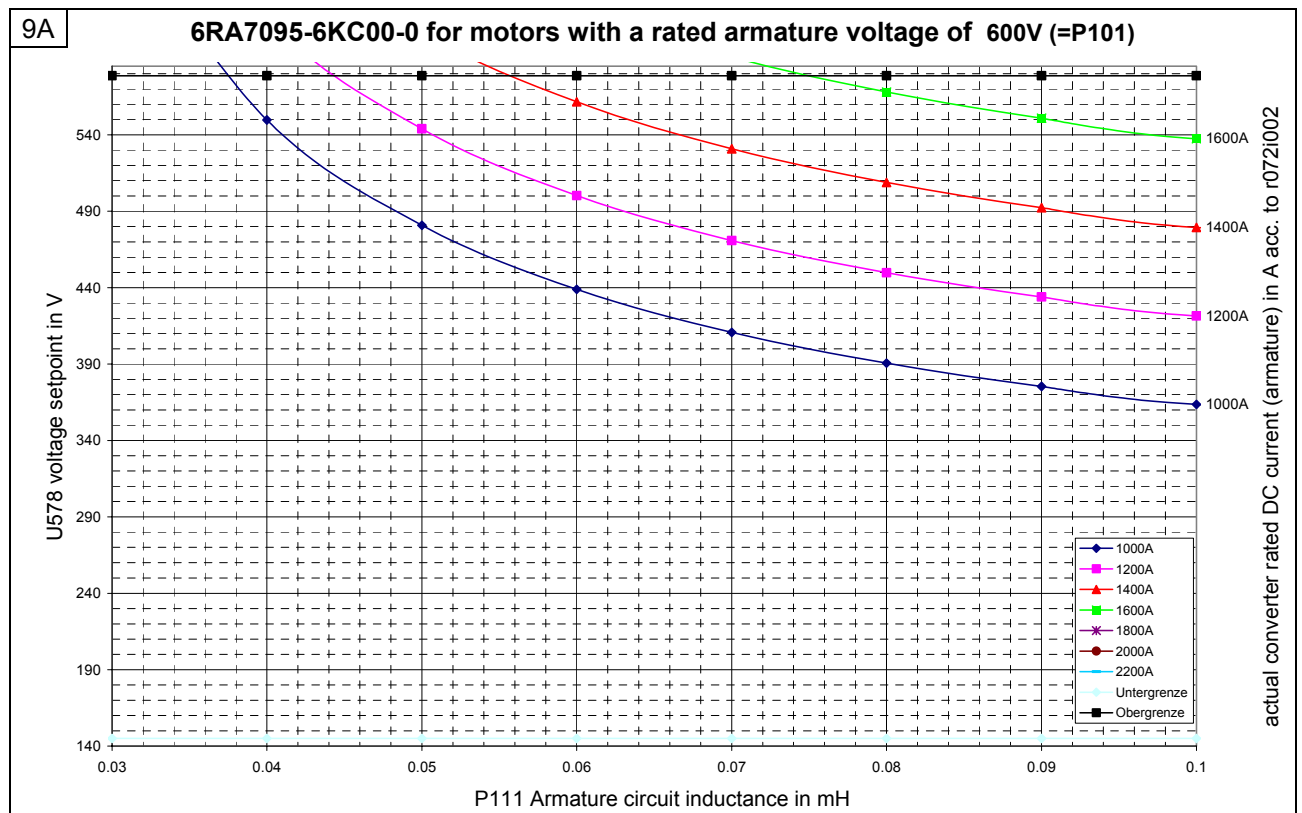
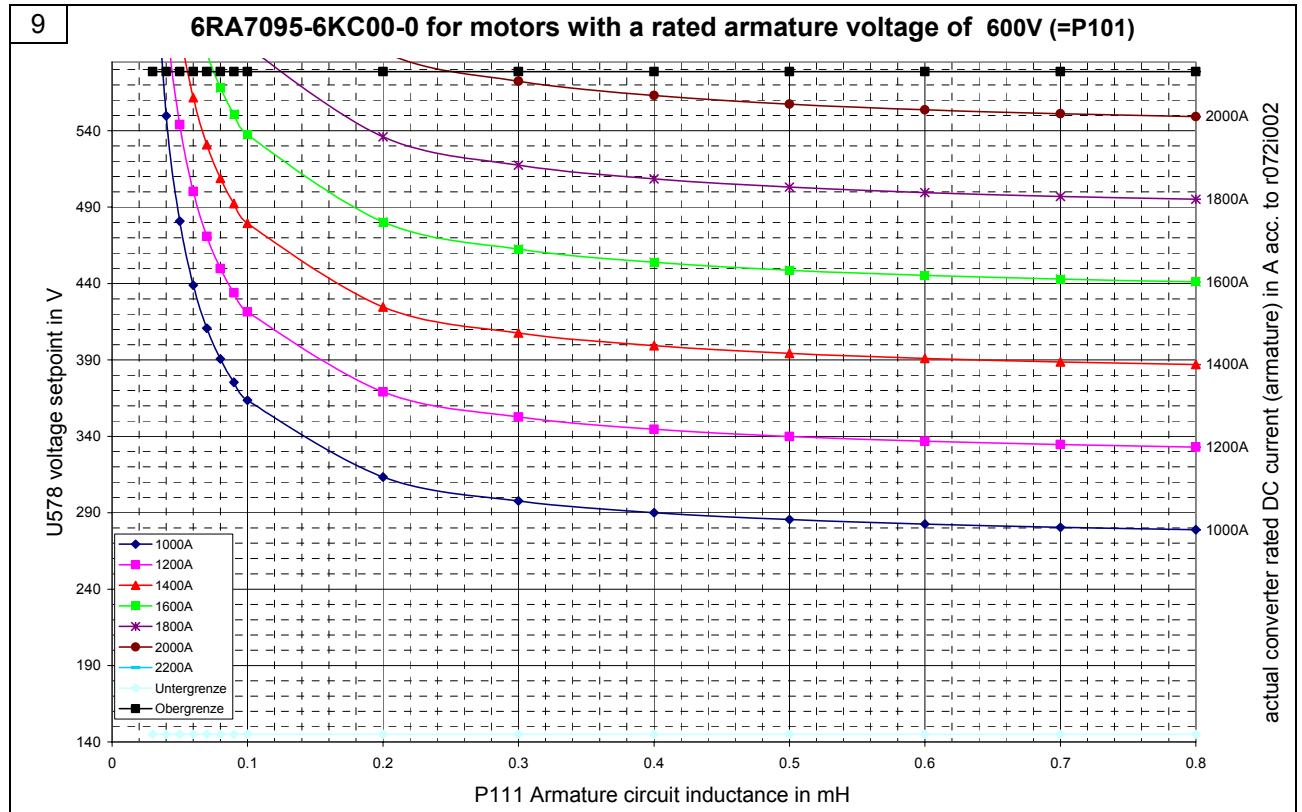

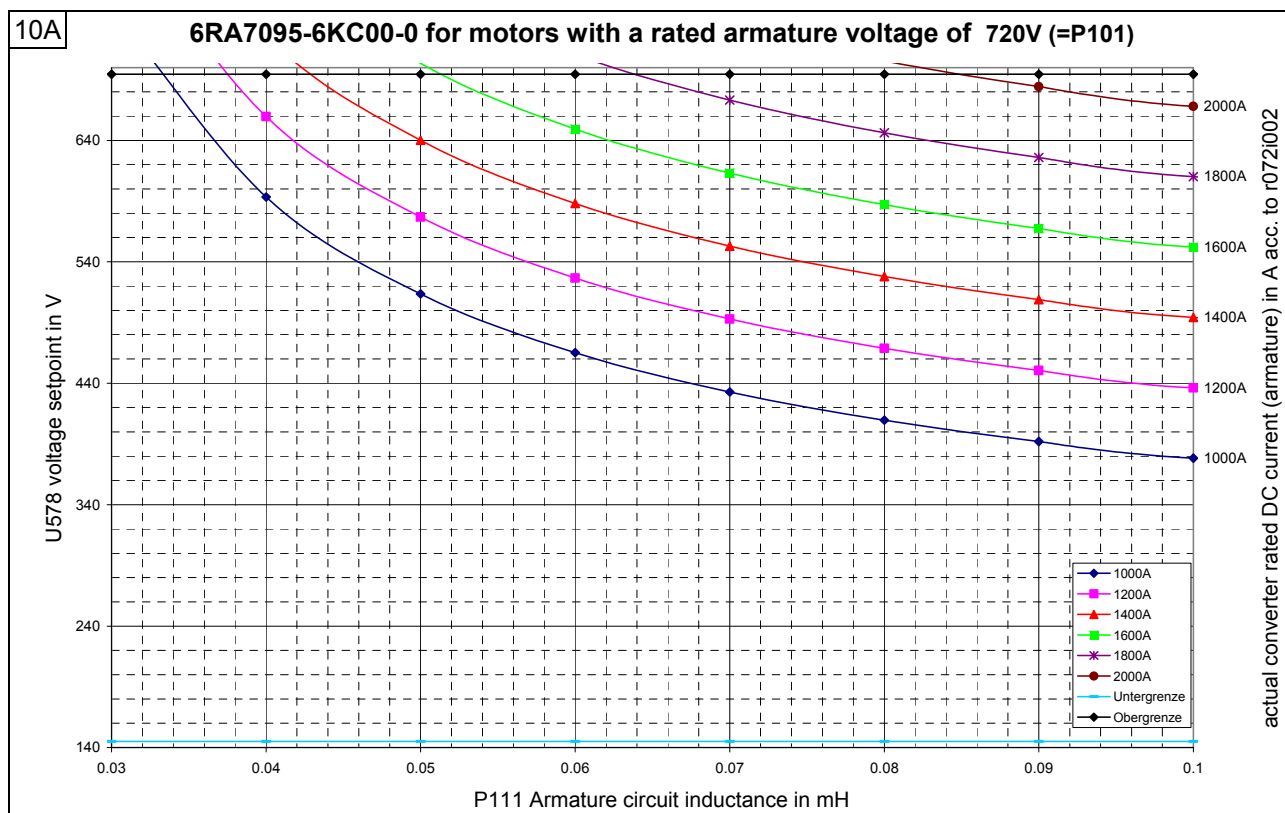
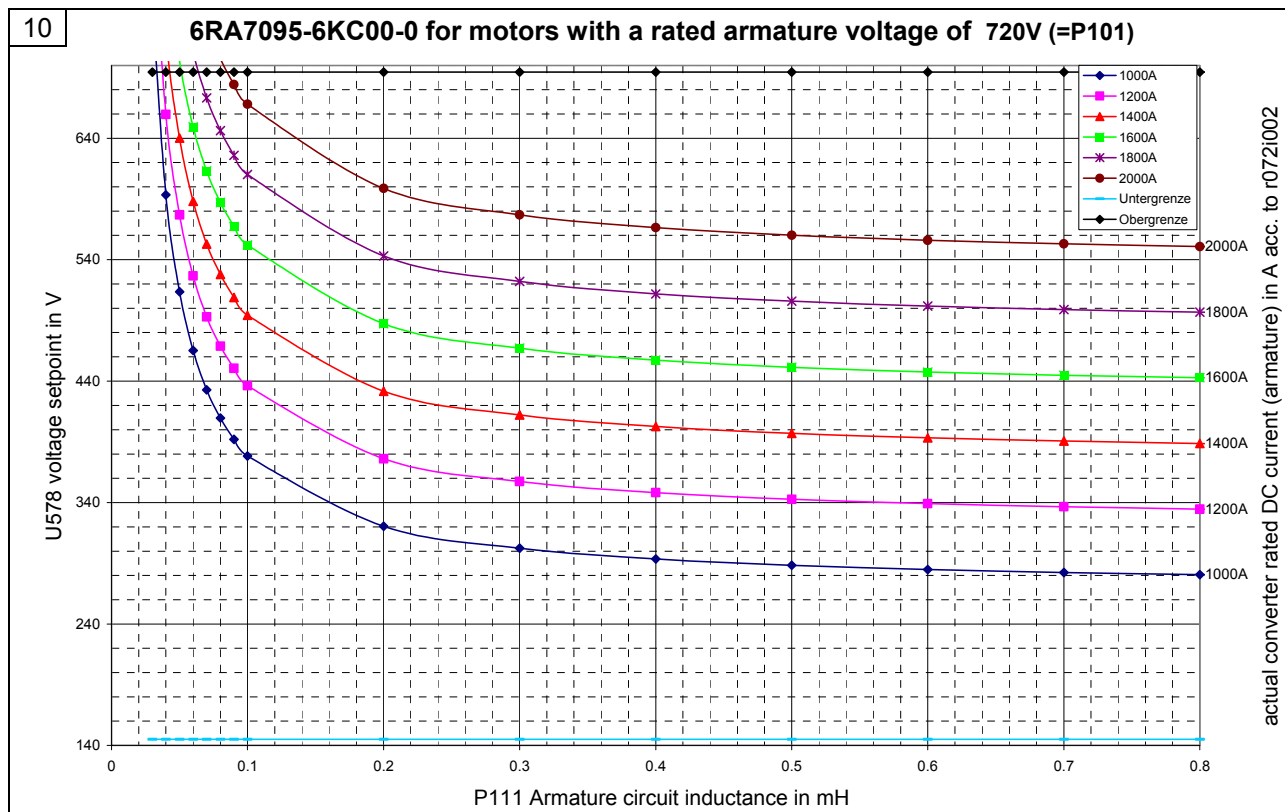

Characteristic diagrams for determining the maximum energy in the armature circuit

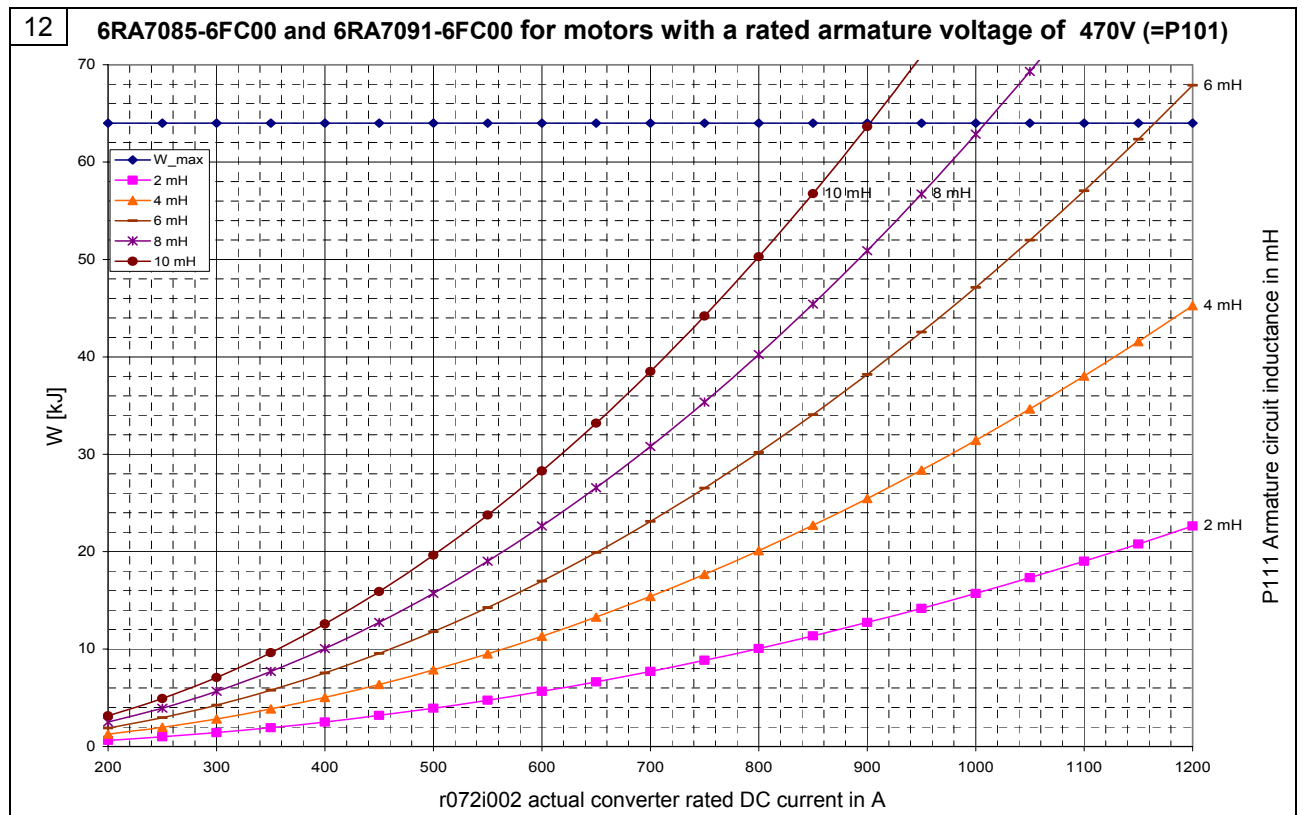
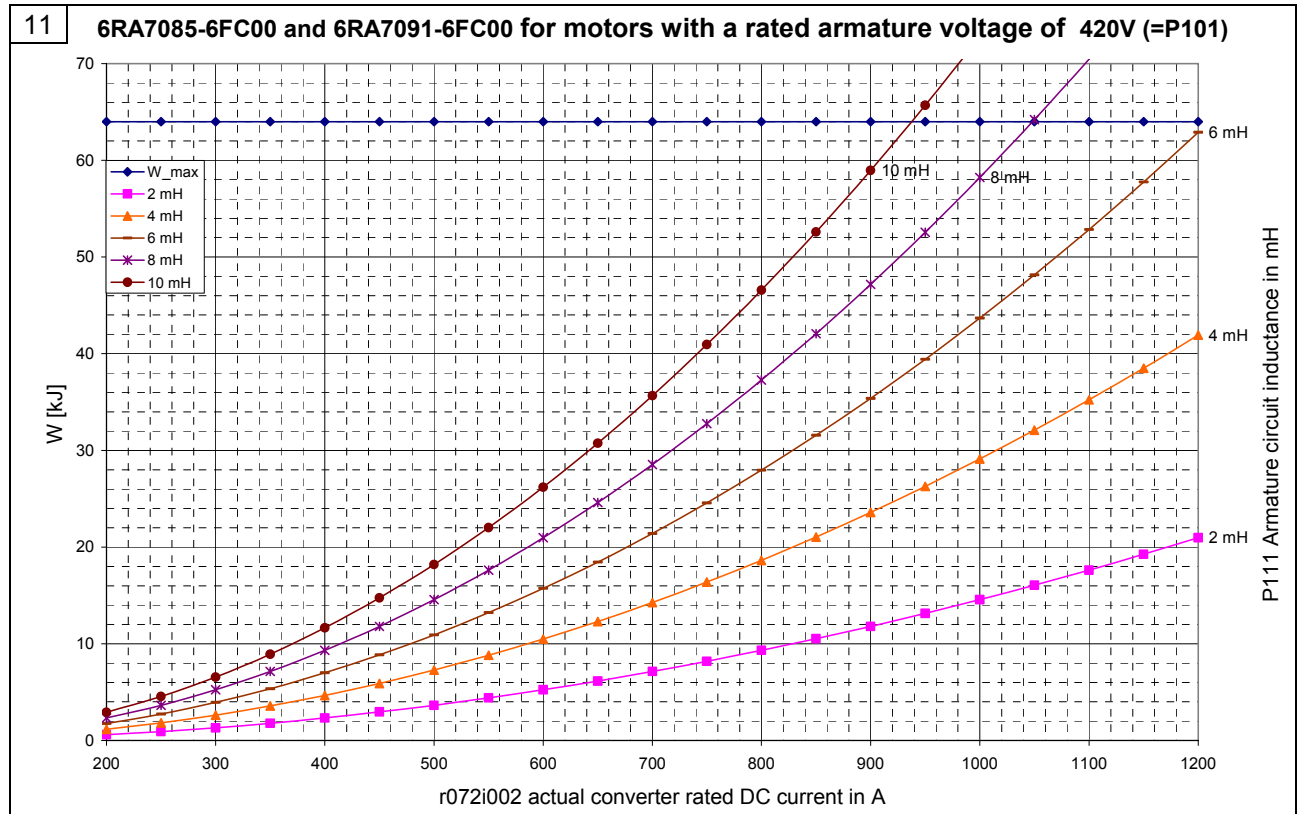

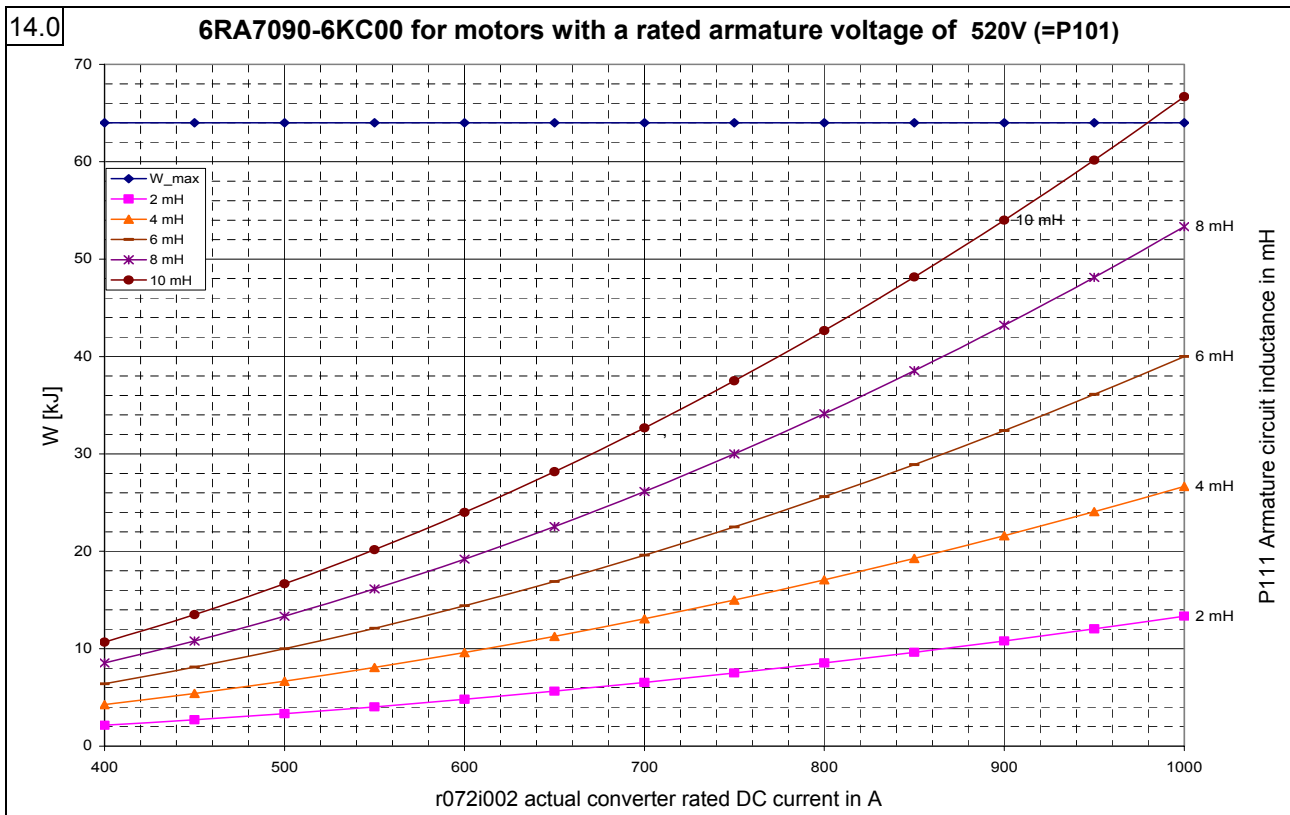
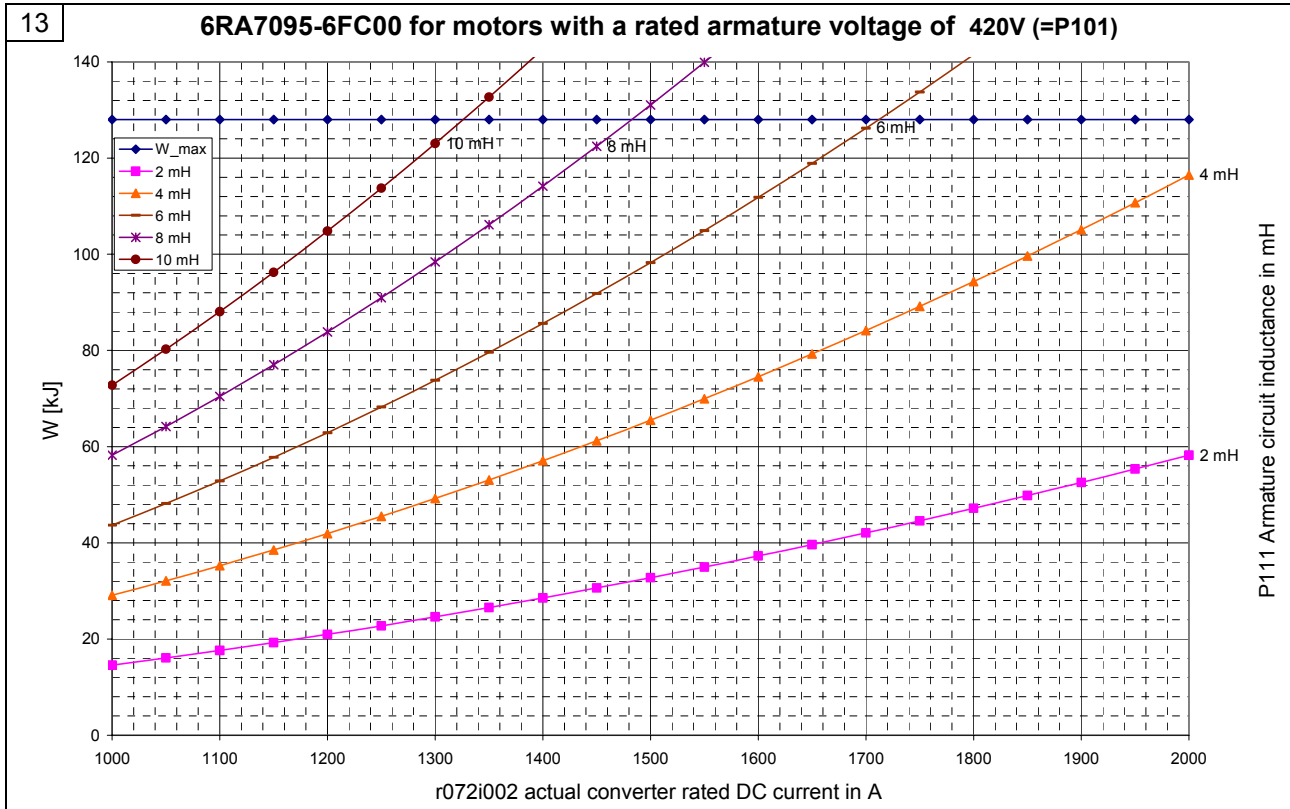

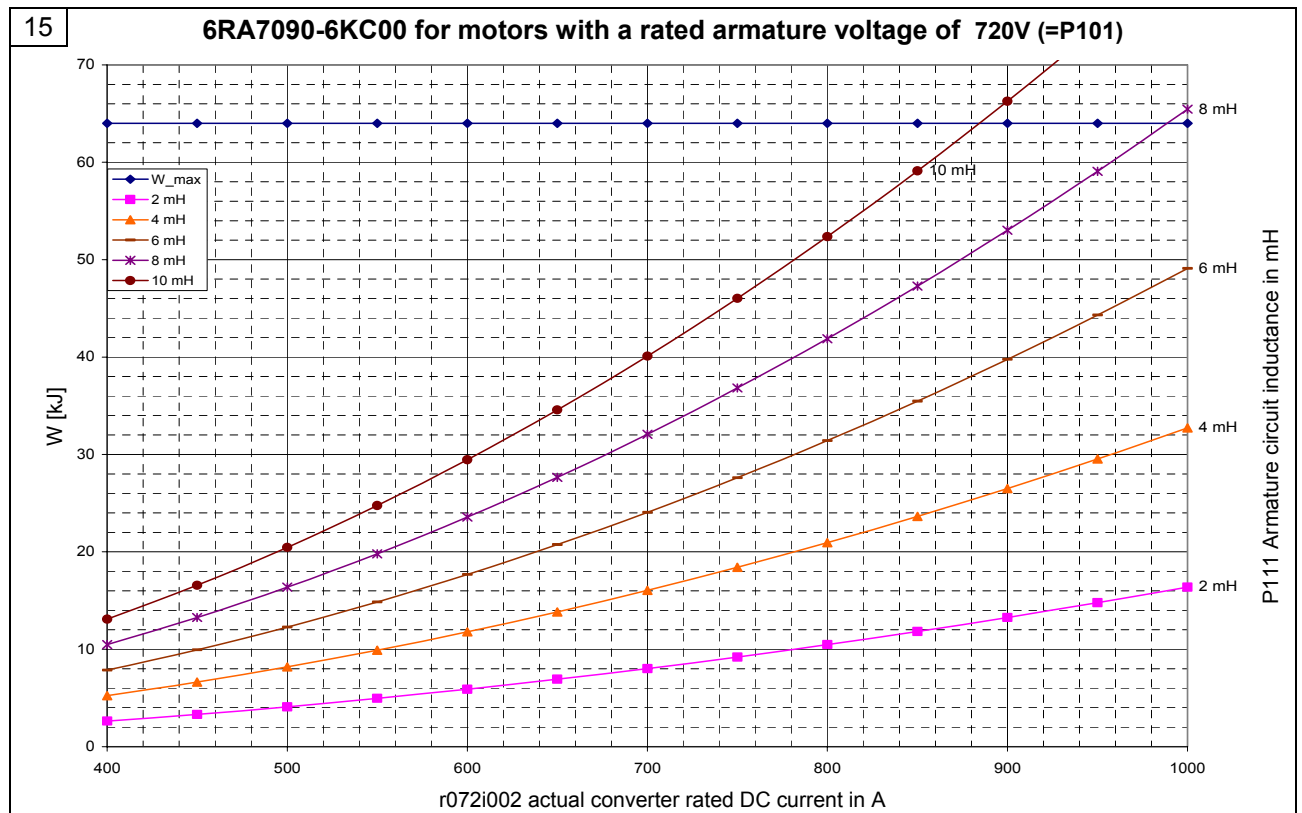
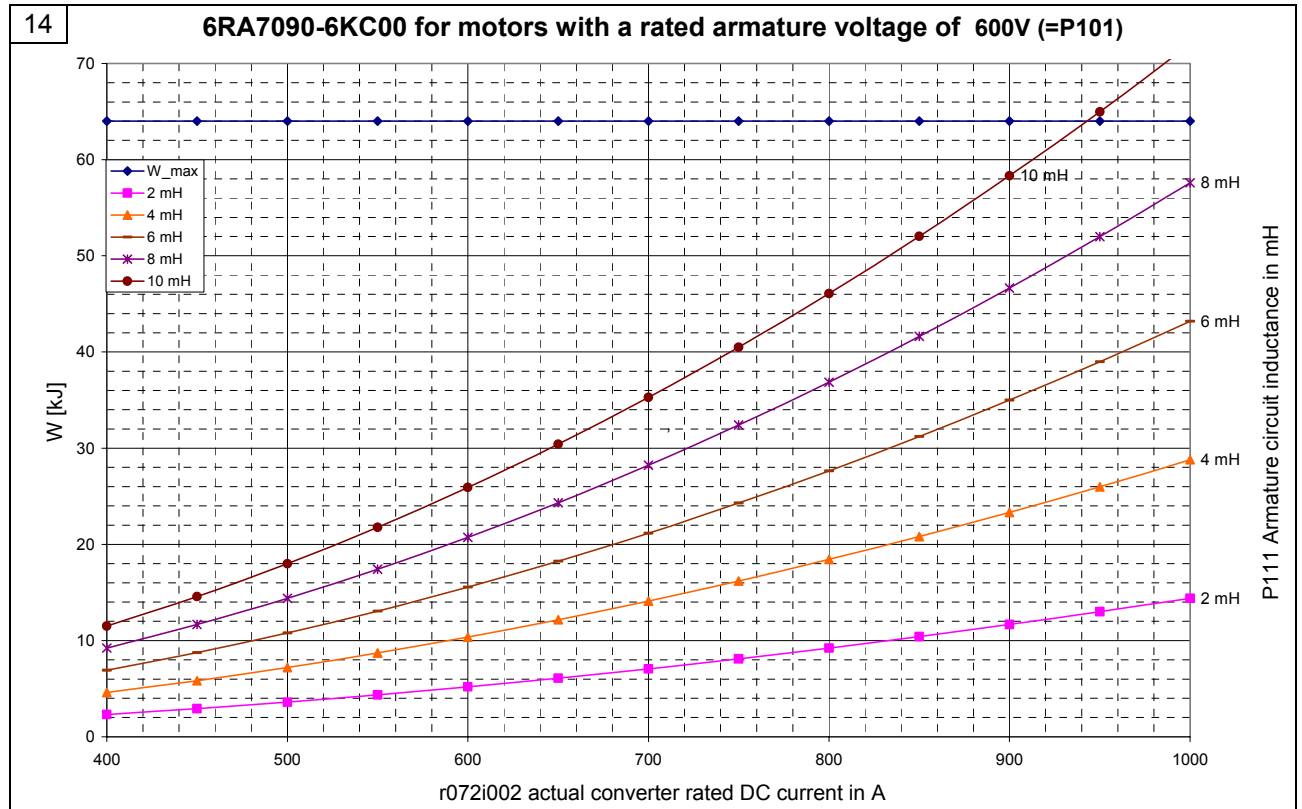

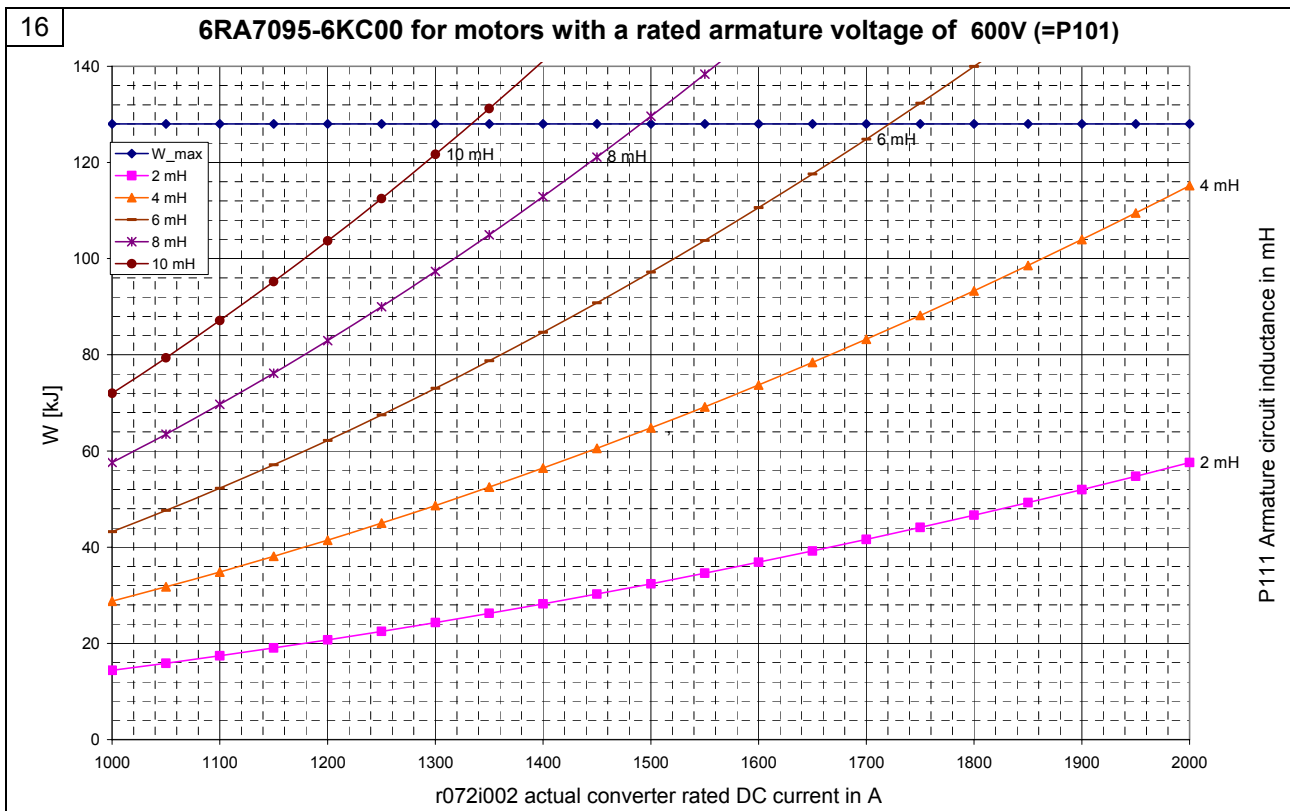
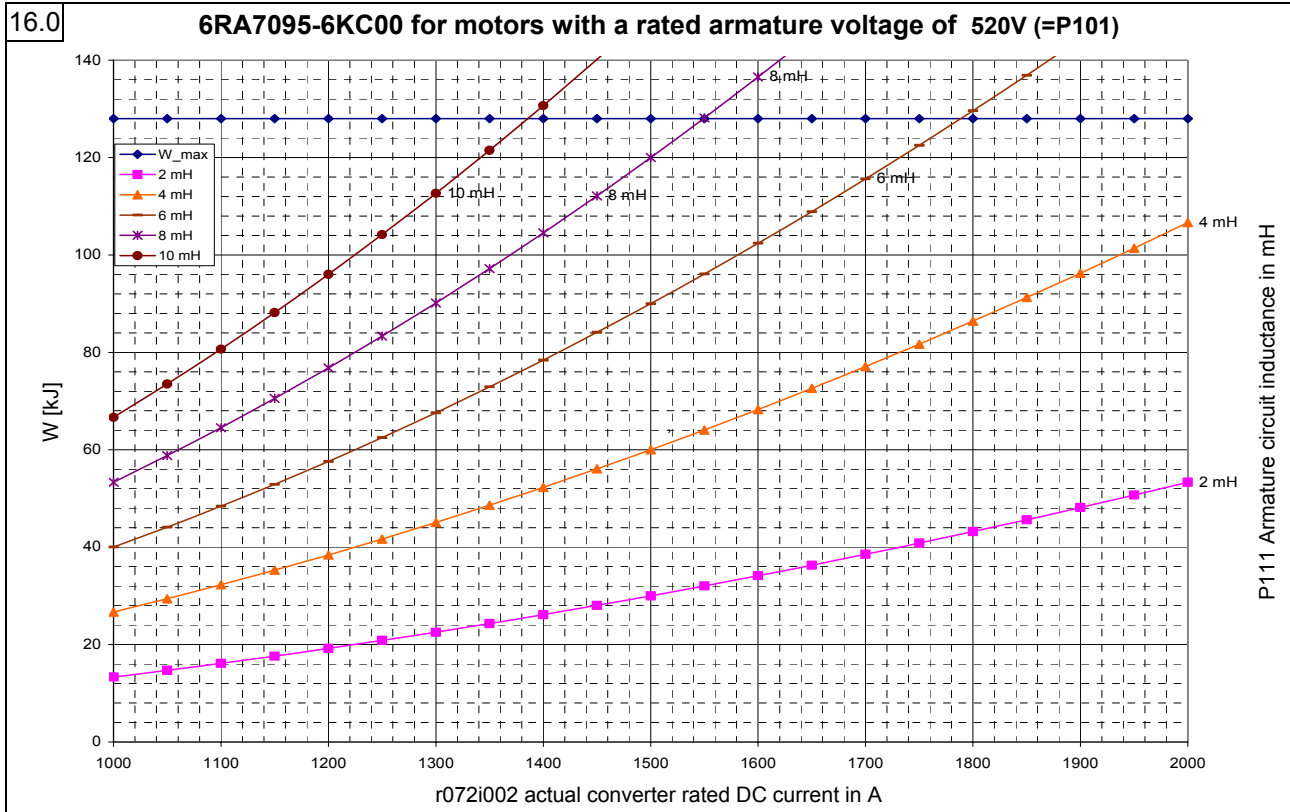

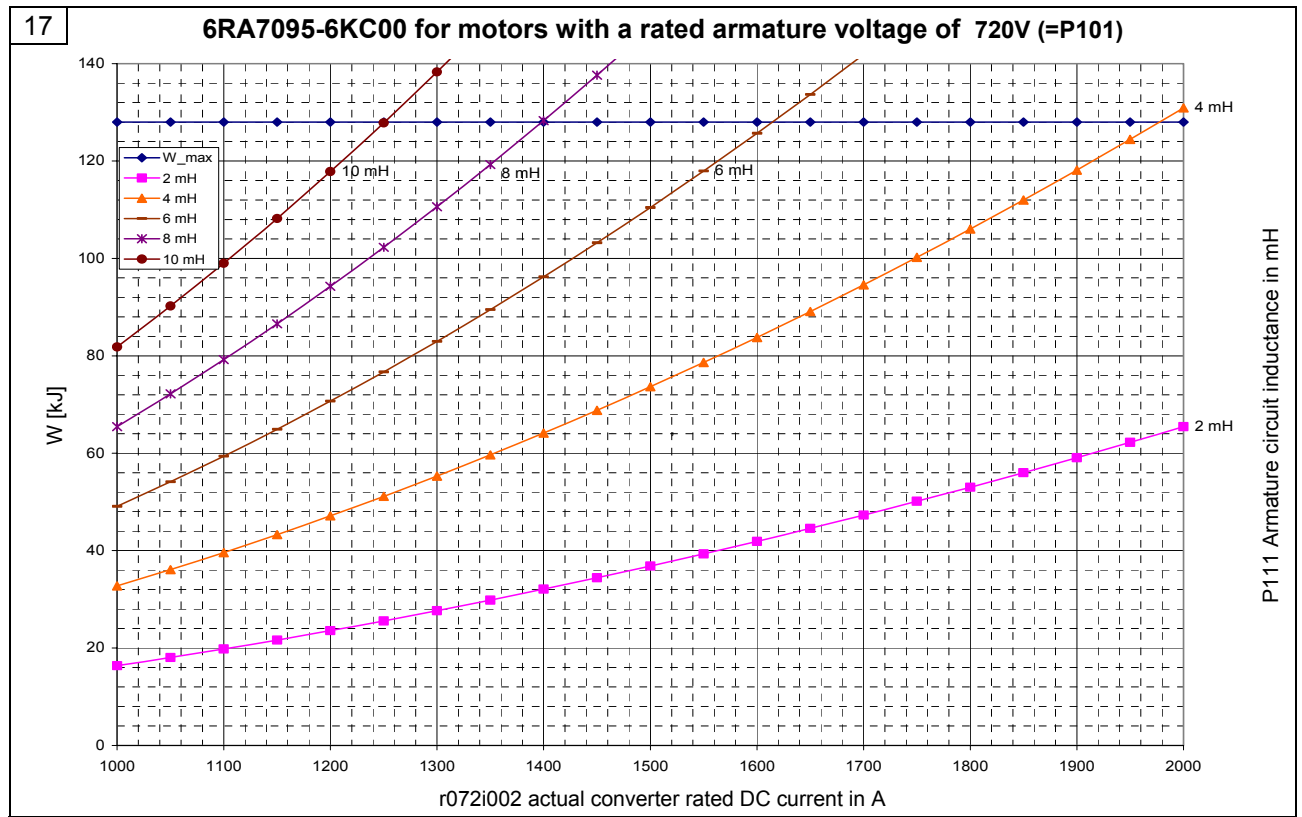

05.2007

Bisher sind folgende Ausgaben erschienen:
The following versions have appeared so far:

Ausgabe Version	interne Sachnummer Internal Part No.
01	C98130-A7046-A1-01-7419
02	C98130-A7046-A1-02-7419
03	C98130-A7046-A1-03-7419