

TI PSL 2000/3000

Power Supply Module PSL 2000/3000

Ausgabe

104

TI PSL 2000/3000

Power Supply Module PSL 2000/3000

Technical Information

1070 078 066-104 (09.93) GB



Reg. Nr. 16149-03

© 1993

Alle Rechte bei Robert Bosch GmbH,
auch für den Fall von Schutzrechtsanmeldungen.
Jede Verfügungsbefugnis, wie Kopier- und Weitergaberecht, bei uns.

Schutzgebühr 5.- DM

1	Safety instructions	1
	Please read the safety instructions prior to installation and commissioning and confirm by signing!	
2	PSL 2000 Power supply modules	5
2.1	Construction	5
2.2	PSL 2000 Types	6
2.3	Technical Data	6
2.3.1	Shared Data	6
2.3.2	Technical Data of PSL 2040.00 L	7
2.3.3	Technical Data of PSL 2100.00 W	8
2.3.4	Technical Data of PSL 2200.00 W	9
2.3.5	Technical Data of PSL 2500.00 W	10
2.4	Dimensions	11
3	Power supply modules PSL 3000	13
3.1	Construction	13
3.2	PSL 3000 types	14
3.3	Technical Data	14
3.3.1	Shared Data	14
3.3.2	Technical data of PSL 3100.00 W	16
3.3.3	Technical data of PSL 3200.00 W	17
3.3.4	Technical data of PSL 3500.00 W	18
3.4	Dimensions	19
4	Installation instructions	21
5	Connection instructions	23
5.1	Mains connection	23
5.2	Transformer connection	24
5.3	Water connection	25

5.4	Connection to timer Module "X1" Terminal Connector	26
5.4.1	Connection to timer modules type PSS 2000	29
5.4.2	Connection to timer modules type E...DYD	30
5.4.3	Connection to timer modules type PE... (ZPS)	30
5.5	Mains Voltage Selection	31
6	Maintenance	33
7	Dimensioning Instructions	35
7.1	Load Diagram	35
7.2	Power Loss diagram	38
8	Fault messages	41
8.1	Temperature monitoring	41
8.2	Protective circuit against transient overvoltages	41
9	Accessories	43
9.1	Water saving device	43
9.2	Shock-protection covers	44

For further information with respect to the **PS 2000** series, the following documentation is available:

1. **Brochure PS 2000** System description, construction, dimensions, function and colored illustrations.
P.-No. 3901
2. **Technical Information PSS with PSP 2000** Construction, dimensions, technical data, installation and connection.
P.-No. 3903
3. **Technical Information PSL 2000/3000** Construction, dimensions, installation and connection.
P.-No. 3904
4. **Operating and Programming Manual PSP 2000** Handling of programming module and programming the weld data according to flow diagram card.
P.-No. 3902
5. **Technical Information and Operating Instructions PSR** Application, function, operation, and programming of the measuring and closed-loop control processes
P.-No. 4028
6. **Technical Information PSS 2081...B** Construction, dimensions, function, options, installation, and connection
P.-No. 3944
7. **Operating and Programming Manual PSS 2081...B** Handling and programming of the weld data using the PR 81 hand-held programming unit
P.-No. 3957

1. Safety instructions

Please read this Technical Information before putting the PSL 2000/3000 Power supply modules into operation.

Store this Technical Information in a place to which all users have access at any time.

Normal use

This Technical Information contains all information concerning the normal use of the products described. The products described serve for precise delayed firing of half-waves of welding transformers.

The products described were developed, manufactured, tested and documented in compliance with all applicable safety standards. Under the condition that the handling instructions and safety instructions issued for engineering, installation and normal use are observed, the product will usually cause no danger for personnel or property.

Qualified personnel

This Technical Information is designed for welding technicians and engineers with special training. They require specific knowledge on the hardware components of the PSS... timer, the power supply module and the welding transformer.

Any interventions in the hardware and software of our products may only be made by our specialized staff unless otherwise described in the present documentation.

Unqualified interventions in the hardware or software or noncompliance with the warnings contained in the present documentation or on the product itself may result in severe injuries or damages to persons or property.

The term qualified personnel refers to

- **engineering personnel** familiar with the safety standards of the electrical and automation technology.
- **operating personnel** who has been instructed for operating installations in resistance welding technology and who know the contents of the present documentation as far as operation is concerned.
- **commissioning personnel** entitled to commission, earth and label electrical circuits and equipment/systems in compliance with the standards of safety technology.

Warnings contained in this Technical Information

The following safety instructions in compliance with the CE standard may generally be given in our Technical Information brochures, their meaning is as follows:



DANGER

This symbol will be used wherever the failure to observe the corresponding safety measures may result in **death**, **severe bodily injury** or considerable **damage to property**. These measures include the following:

- Safety disconnection
- Protect against reclosing
- Verify safe isolation from supply
- Earthing and short-circuiting
- Cover or barrier adjacent live parts



WARNING

This symbol will be used wherever insufficient or lacking compliance with the instructions may result in **personal injury**.



ATTENTION

This symbol will be used wherever insufficient or lacking compliance with the instructions may result in **damage to equipment or files**.



NOTE

This symbol will be used to inform the user on special features.

Warnings at the timer components

The following warnings and notes may be attached to the actual timer components which are designed to inform the user on certain circumstances.



Warning of dangerous voltages!



Warning of dangers in connection with accumulators!



Components subject to electrostatic induction!



Disconnect mains plug before opening!



Pin only designed for connecting the PE (protective earth) conductor!

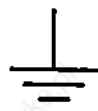

Only for connecting a shield conductor!

Power supply module
Type PSL 2000/3000



2 PSL 2000 Power supply modules

2.1 Construction

The power supply modules of the PSL 2000 series contain the power thyristor which serves as an a.c. power controller and the mains supply for the timer and programming module.

The power supply modules are mounted to a metal base frame and can be either installed directly in welding machines or switch cabinets, or in separate housings.

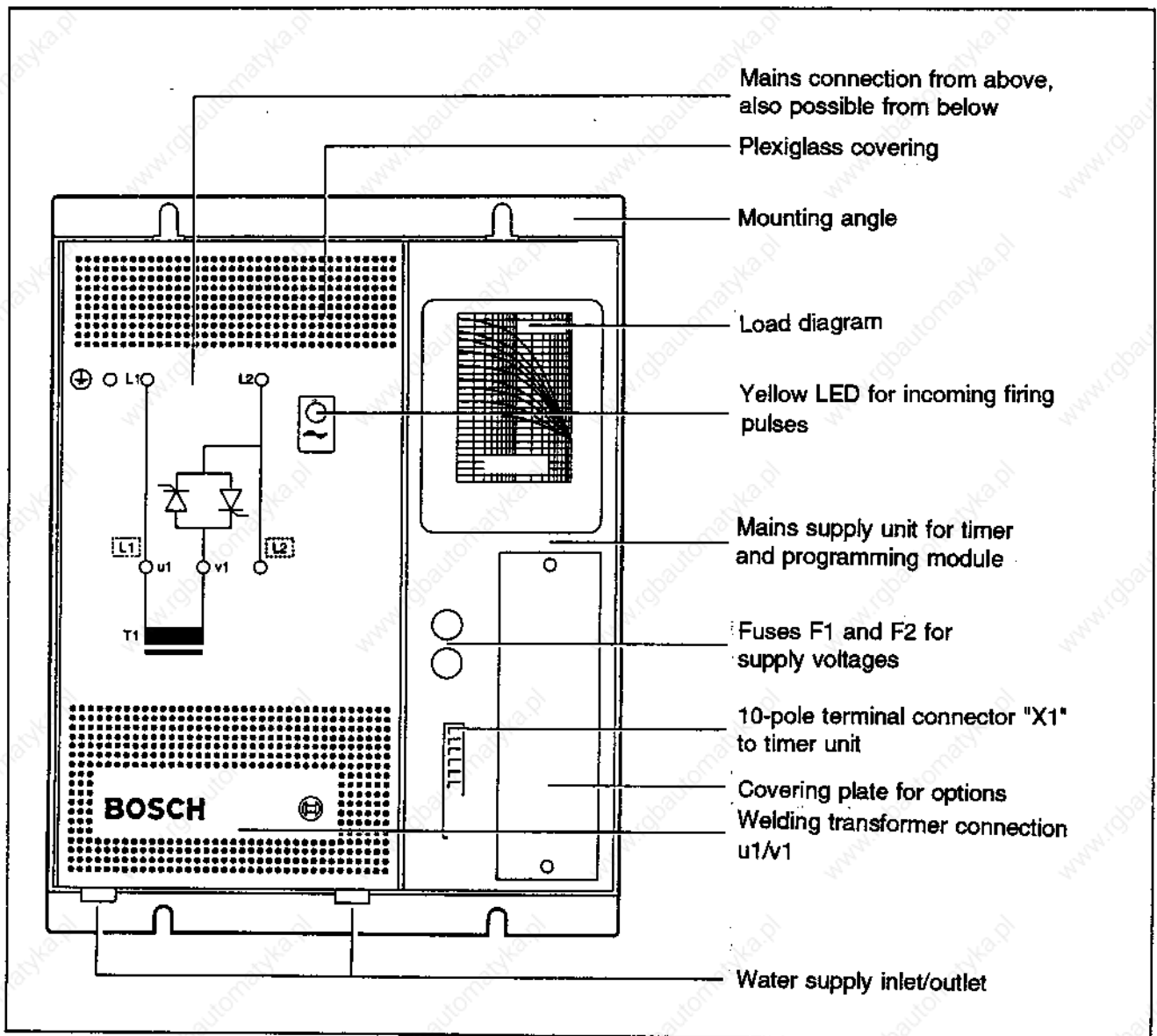

Fig. 2.1 PSL 2000

2.2 PSL 2000 Types

Type name	Drawing no.	Cooling	Power [kVA]*	Operating voltage
PSL 2040.00 L	211 052 186	Air	40	220 V
PSL 2100.00 W	211 052 187	Water	100	up to
PSL 2200.00 W	211 052 188	Water	200	550 V
PSL 2500.00 W	211 052 824	Water	500	

* approximately corresponds to the output of the welding transformer types at 50 % duty cycle (ED).

2.3 Technical Data

2.3.1 Shared Data

Type of construction	Thyristor a.c. power controller as built-in module in open construction (protection standard IP 00).
Connected voltage	220/380/415-440/500-550 V, 50/60 Hz (Set to 380 V when delivered, can be changed over to other voltages by customer, section 5.5), admissible voltage variations +15%, -20%
Percentage duty cycle	independent from the possible thyristor switching currents, limited by built-in de-excitation resistor up to 380 V - 100% duty cycle up to 440 V - 75% duty cycle up to 550 V - 50% duty cycle (integration time ≤ 1 minute)
Thyristor off-state voltage	1600 V
Supply voltage for PSS timer module	27 V a.c. (fuse M 1.25 A) 24 V d.c. (fuse M 2.5 A)
Overvoltage protection	by MOV (metal-oxide varistor)

2.3.2 Technical Data of PSL 2040.00 L



Installed load	for welding transformers up to approx. 40 kVA (at 380 V). Max. admissible switching currents depend on duty cycle and weld times (see load diagram)
Cooling	Air cooling (self-convection). Heat sink temperature max. 80° C, thermostatically controlled. Load capacity depends on max. heat sink temperature (see diagram Fig. 7.4).
Ambient temperature	max. 55° C (valid for load diagram; observe installation instructions)

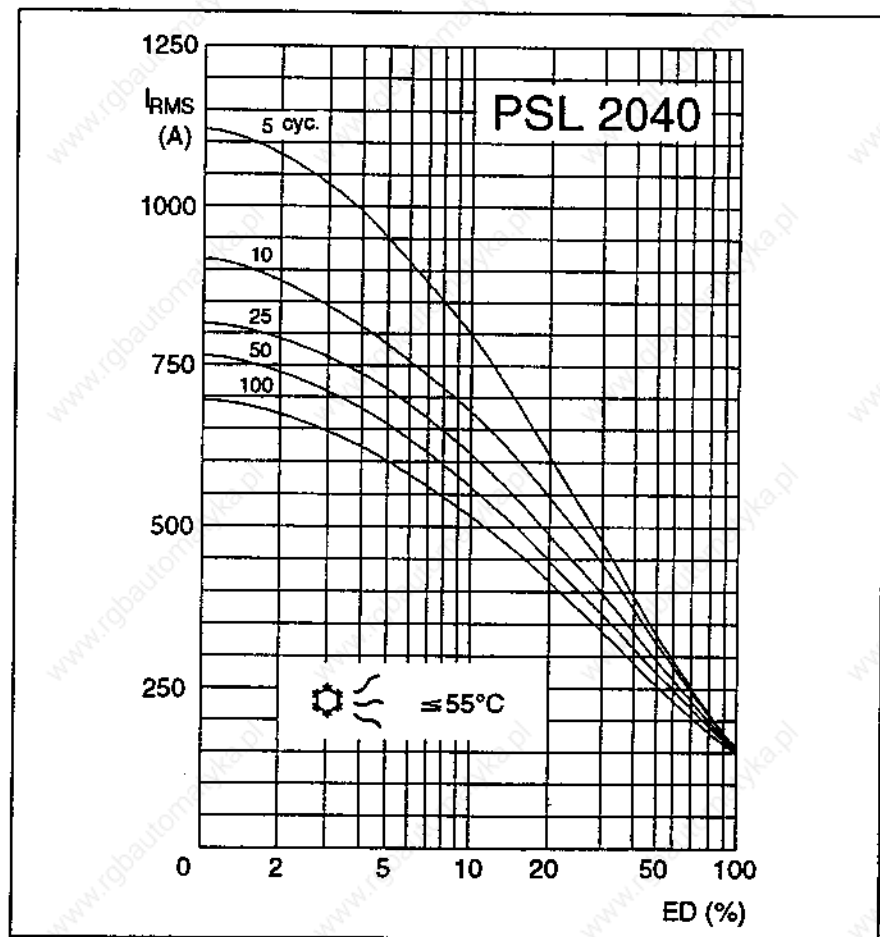

Fig. 2.2 Load Diagram

2.3.3 Technical Data of PSL 2100.00 W



Installed load	for welding transformers up to approx. 100 kVA (at 380 V). Max. admissible switching currents depend on duty cycle and weld times (see load diagram)
Cooling	Water cooling Max. water inlet temperature 40° C, water flow rate ≥ 4 liters/min., differential inlet-outlet ≤ 1 bar at 4 liters/min. Cooling thermostatically controlled
Water connection	Inlet and outlet: External thread G 3/8", taper steps to DIN 8542
Ambient temperature	max. 55° C (valid for load diagram; observe installation instructions)

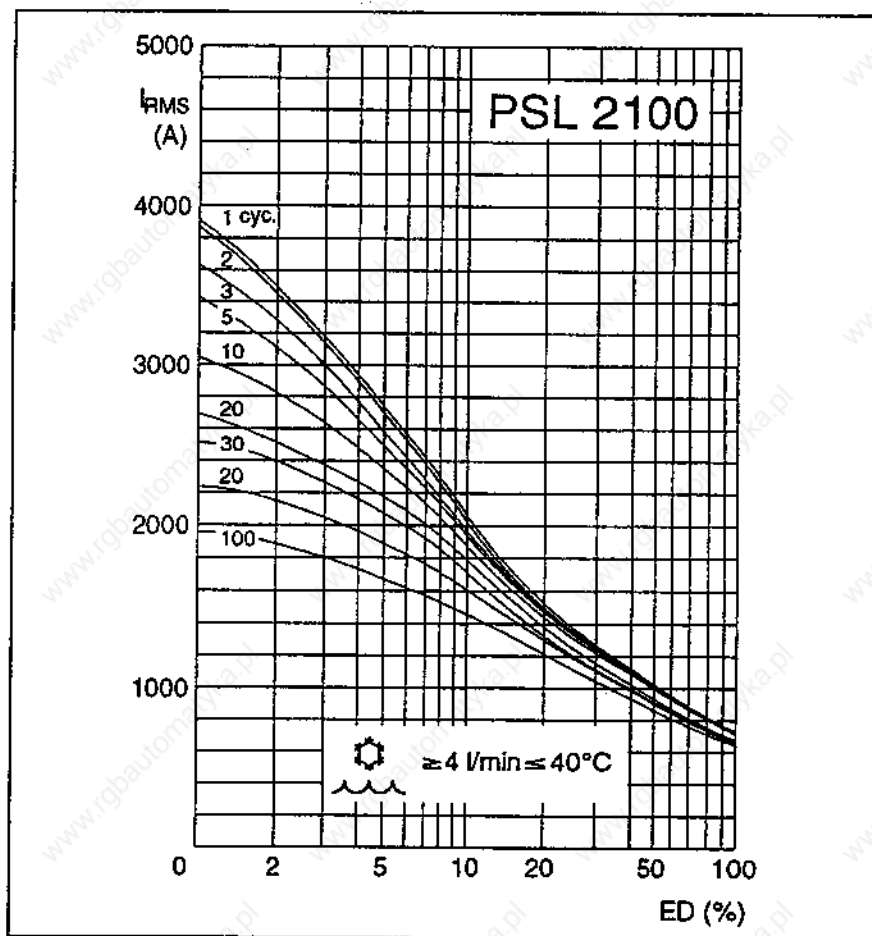

Fig. 2.3 Load Diagram

2.3.4 Technical Data of PSL 2200.00 W

Installed load	for welding transformers up to approx. 200 kVA (at 380 V). Max. admissible switching currents depend on duty cycle and weld times (see load diagram)
Cooling	Water cooling Max. water inlet temperature 40° C, water flow rate ≥ 4 liters/min., differential inlet-outlet ≤ 1 bar at 4 liters/min. Cooling thermostatically controlled
Water connection	Inlet and outlet: External thread G 3/8", taper steps to DIN 8542
Ambient temperature	max. 60° C (valid for load diagram; observe installation instructions)

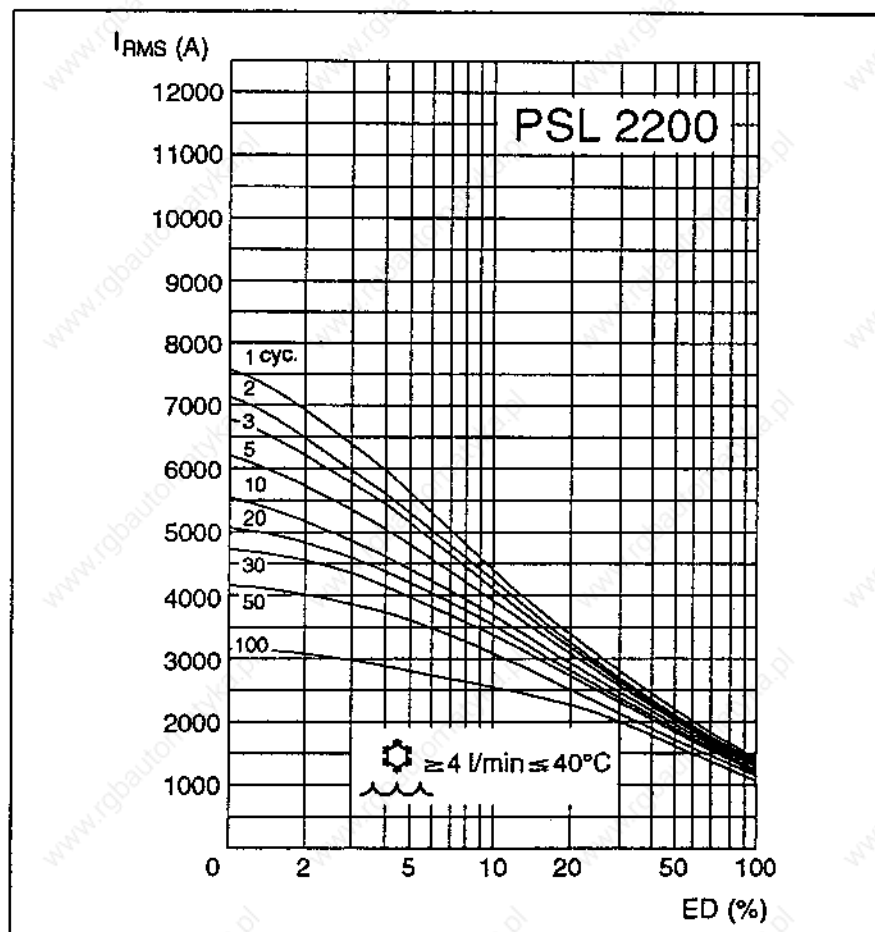

Fig. 2.4 Load Diagram

2.3.5 Technical Data of PSL 2500.00 W



Installed load	for welding transformers up to approx. 500 kVA (at 380 V). Max. admissible switching currents depend on duty cycle and weld times (see load diagram)
Cooling	Water cooling Max. water inlet temperature 40° C, water flow rate ≥ 4 liters/min., differential inlet-outlet ≤ 1 bar at 4 liters/min. Cooling thermostatically controlled
Water connection	Inlet and outlet: External thread G 3/8", taper steps to DIN 8542
Ambient temperature	max. 60° C (valid for load diagram; observe installation instructions)

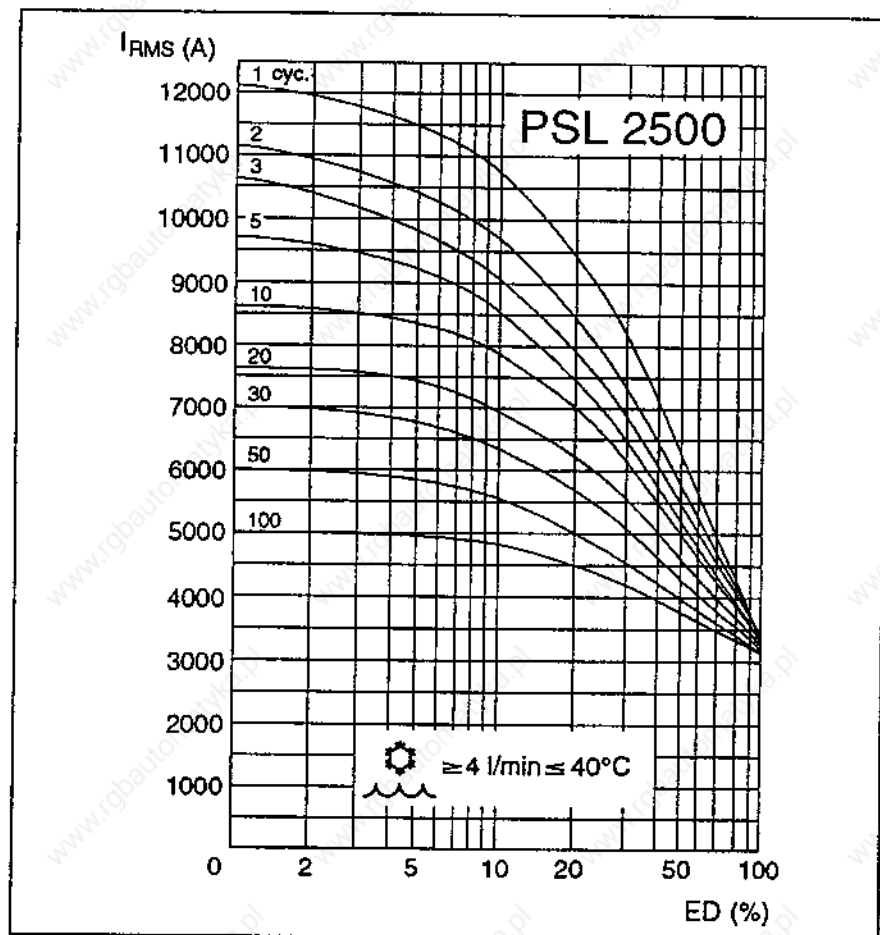

Fig. 2.5 Load Diagram

2.4 Dimensions

The dimensions of the PSL 2000 power supply modules only differ in their widths. All other dimensions are identical.

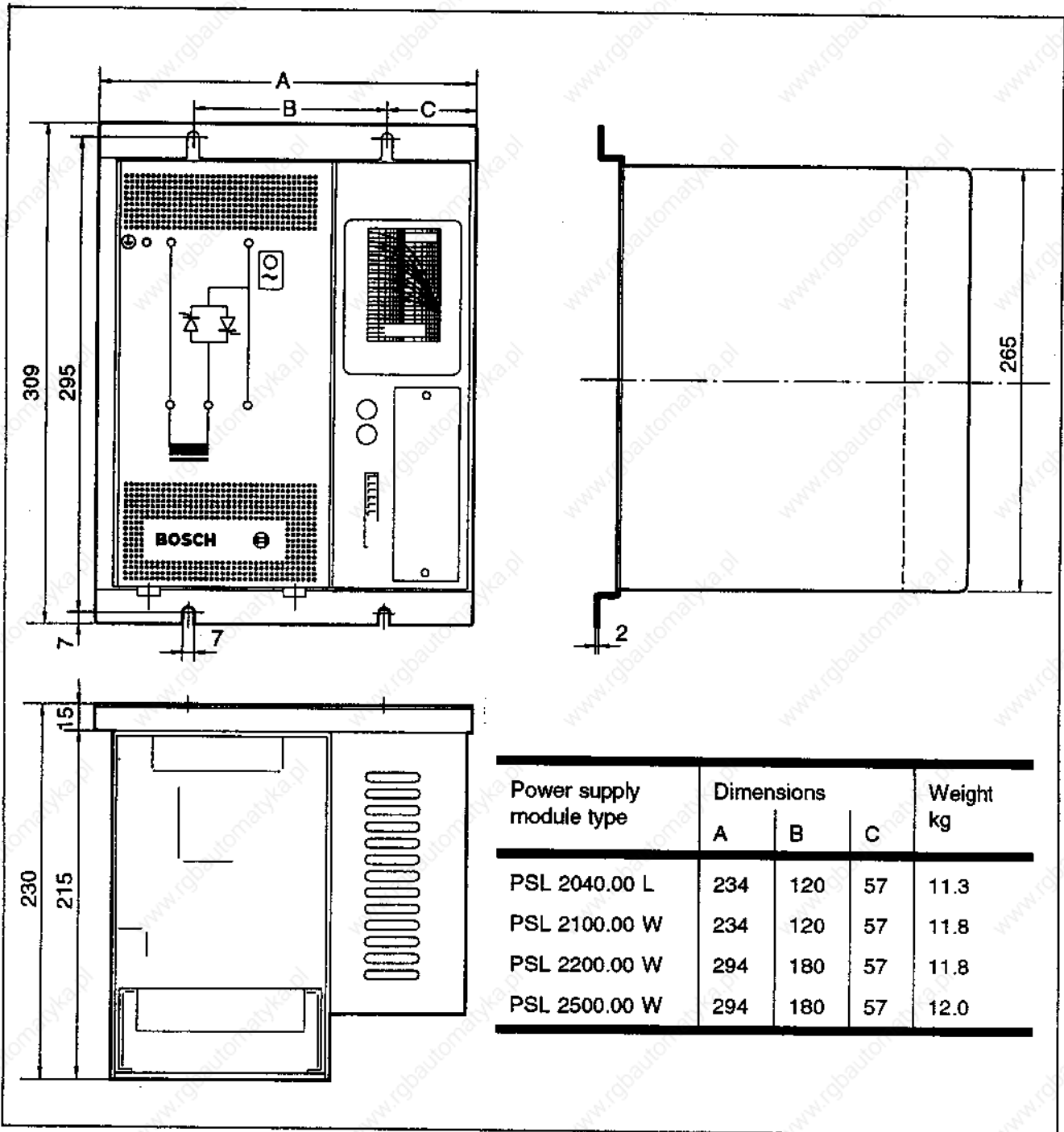

Fig. 2.6 Dimensions

**Power supply module
Type PSL 2000/3000**



3 Power supply modules PSL 3000

3.1 Construction

The power and supply modules of the PSL 3000 series are equipped with three power thyristors serving as three-phase a.c. power controllers for three welding transformers connected in series. The integrated adapter module acts as a firing (weld) pulse unit, controlling the three thyristor blocks. The power supply modules also provide power supply for the timer and programming module.

The power supply modules are mounted to a metal base frame and can be either installed directly in welding machines or switch cabinets, or in separate housings.

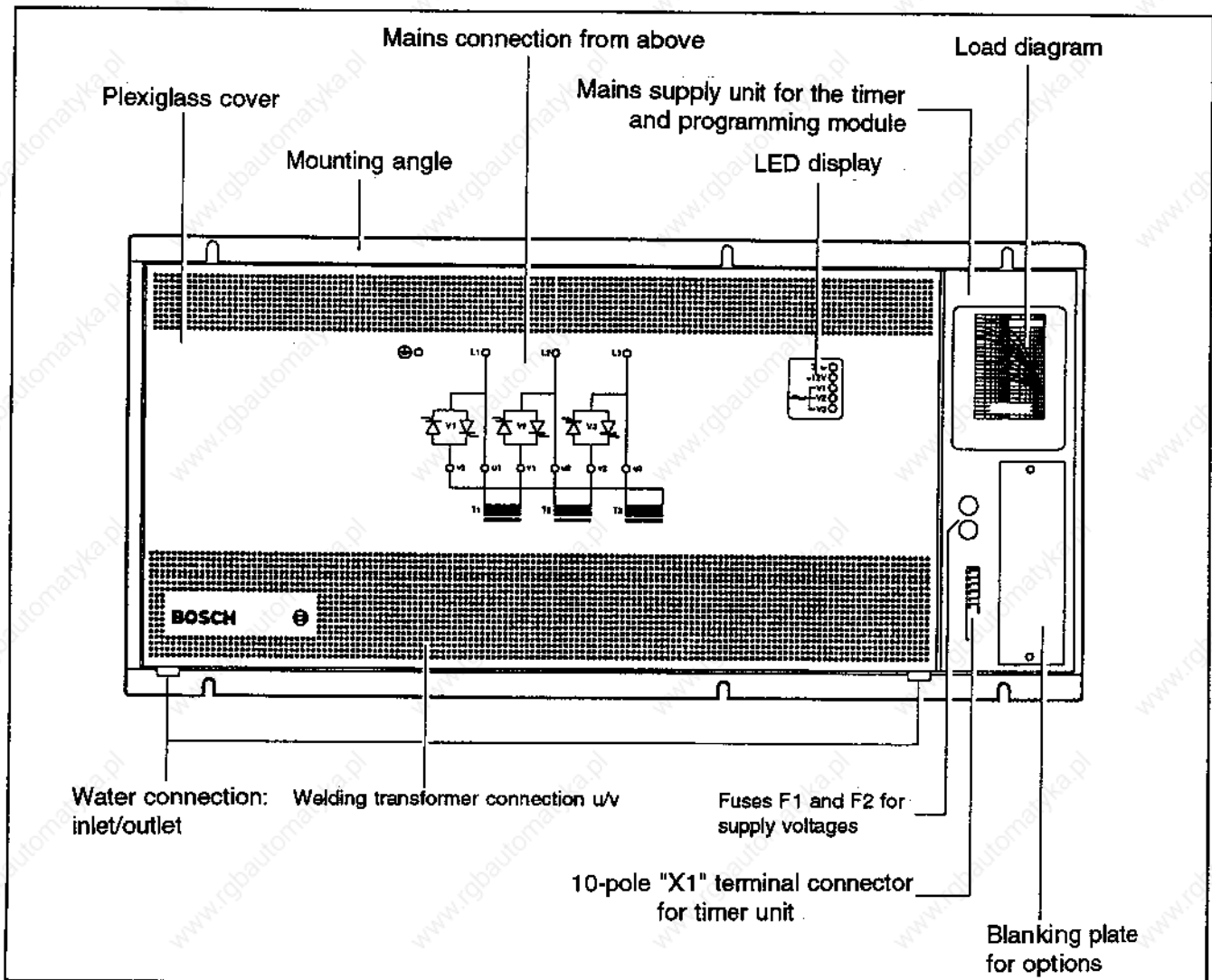

Fig. 3.1 PSL 3000

3.2 PSL 3000 types

Type name	Drawing no.	Cooling	Power [kVA]*	Operating voltage
PSL 3100.00 W	052 115	Water	3 x 100	220 V
PSL 3200.00 W	052 791	Water	3 x 200	up to
PSL 3500.00 W	052 792	Water	3 x 500	550 V

* approximately corresponds to the power of the welding transformer types at 50% duty cycle (ED).

3.3 Technical Data

3.3.1 Shared Data

Type of construction	Three-phase thyristor a.c. power controller as built-in module in open construction (protection standard IP 00).
Connected voltage	220/380/415-440/500-550 V, 50/60 Hz (Set to 380 V when delivered, can be changed over to other voltages by customer, section 5.5), admissible voltage variations +15%, -20%
Percentage duty cycle	independent from the possible thyristor switching currents, limited by built-in de-excitation resistor up to 380 V - 100% duty cycle up to 440 V - 75% duty cycle up to 550 V - 50% duty cycle (integration time ≤ 1 minute)
Thyristor off-state voltage	1600 V
Supply voltage for PSS timer module	27 V a.c. (fuse M 1.25 A) 24 V d.c. (fuse M 2.5 A)
Oversvoltage protection	by MOV (metal-oxide varistor)

Monitoring	<p>The 3-phase adapter is integrated into the power supply module, its functions include:</p> <ul style="list-style-type: none"> - phase monitoring, clockwise rotating phase sequence Display via green LED "3~" - logic voltage/phase monitoring +12V, Display via green LED "+12V" - weld pulses (5 kHz) Display via 3 x yellow LED's
Cooling	<ul style="list-style-type: none"> - water cooling - max. water inlet temperature 40°C - water flow rate ≥ 8 liters/minute - differential inlet-outlet ≤ 1 bar at 8 liters/minute - cooling monitored by thermostat (bimetallic switch opens at 56°C, $\pm 5^\circ\text{C}$)
Water connection	<p>inlet and outlet: G 3/8" external thread taper steps according to DIN 8542</p>
Ambient temperature	<p>max. 60° C (observe installation instructions)</p>

3.3.2 Technical data of PSL 3100.00 W

Installed load	for welding transformers up to approx. 100 kVA (at 380 V), the max. admissible switching currents depend on duty cycle and weld times (see load diagram)
Electrical connection	mains connection (L1/L2/L3) and protective earth conductor from above outgoing transformer feeder 3 x UV and protective conductor from below via threaded pins M8
Connection to timer	via 10-pole terminal connector (cable 10 x 1.5 mm ² up to max. 75 m). When operated with timers of the E81.. and ZPS series, connectors 8 to 10 are not used .

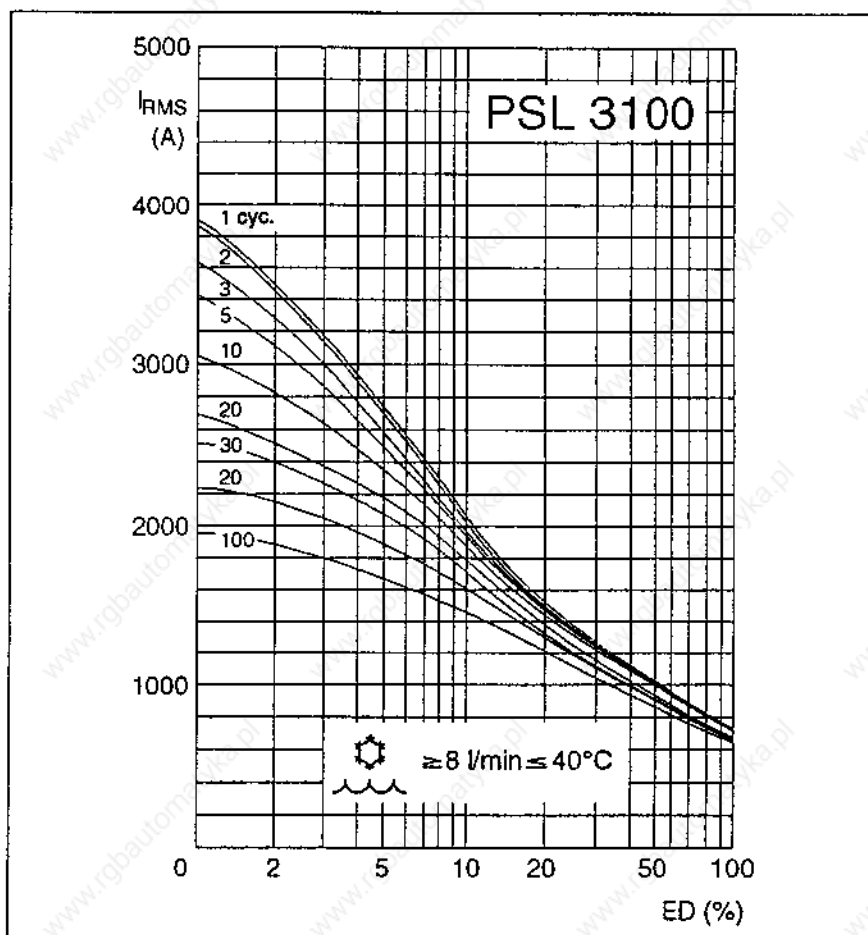

Fig. 3.2 Load diagram

3.3.3 Technical data of PSL 3200.00 W

Installed load	for welding transformers up to approx. 200 kVA (at 380 V), the max. admissible switching currents depend on duty cycle and weld times (see load diagram)
Electrical connection	mains connection (L1/L2/L3) and protective earth conductor from above outgoing transformer feeder 3 x UV and protective conductor from below via threaded pins M12
Connection to timer	via 10-pole terminal connector (cable 10 x 1.5 mm ² up to max. 75 m). When operated with timers of the E81.. and ZPS series, connectors 8 to 10 are not used .

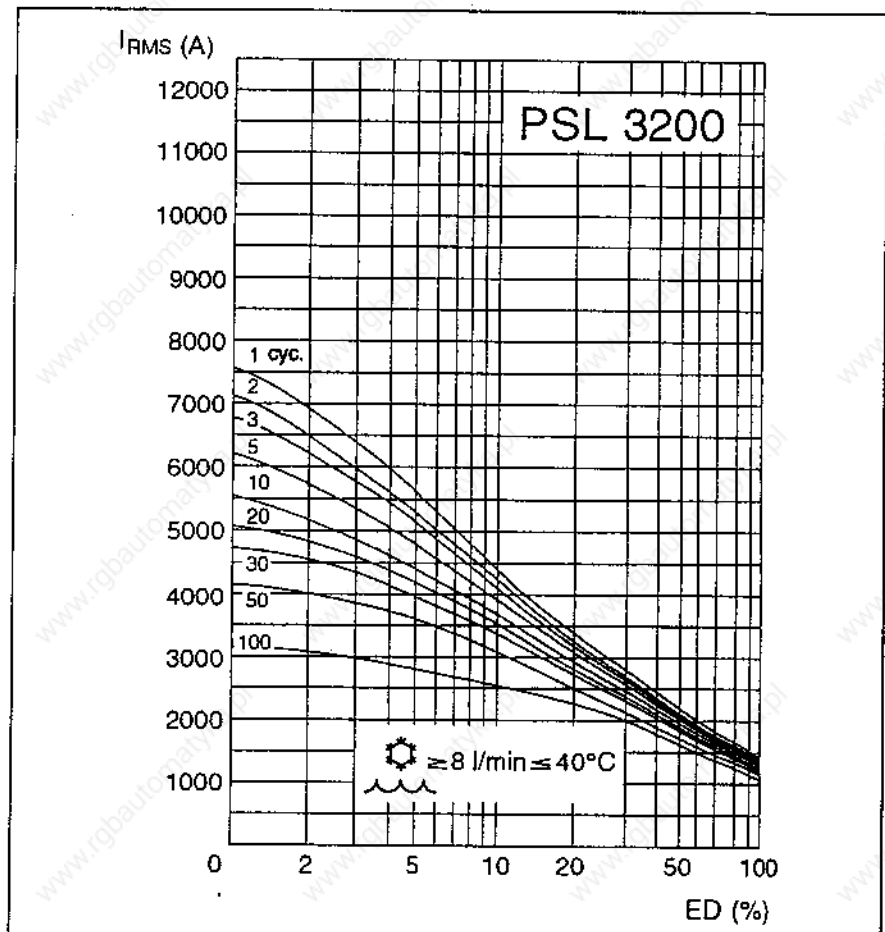

Fig. 3.3 Load diagram

3.3.4 Technical data of PSL 3500.00 W

Installed load	for welding transformers up to approx. 500 kVA (at 380 V), the max. admissible switching currents depend on duty cycle and weld times (see load diagram)
Electrical connection	mains connection (L1/L2/L3) and protective earth conductor from above outgoing transformer feeder 3 x UV and protective conductor from below via threaded pins M12
Connection to timer	via 10-pole terminal connector (cable 10 x 1.5 mm ² up to max. 75 m). When operated with timers of the E81.. and ZPS series, connectors 8 to 10 are not used .

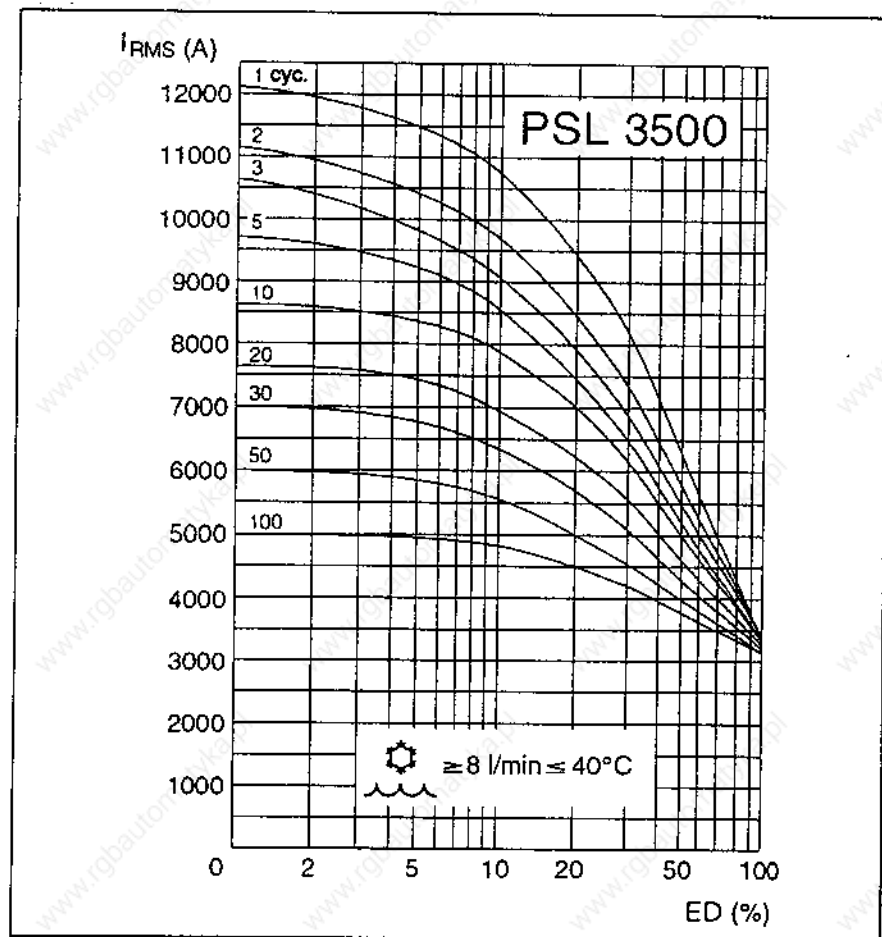

Fig. 3.4 Load diagram

3.4 Dimensions

The dimensions of the PSL 3000 power supply modules only differ in their widths. All other dimensions are identical.

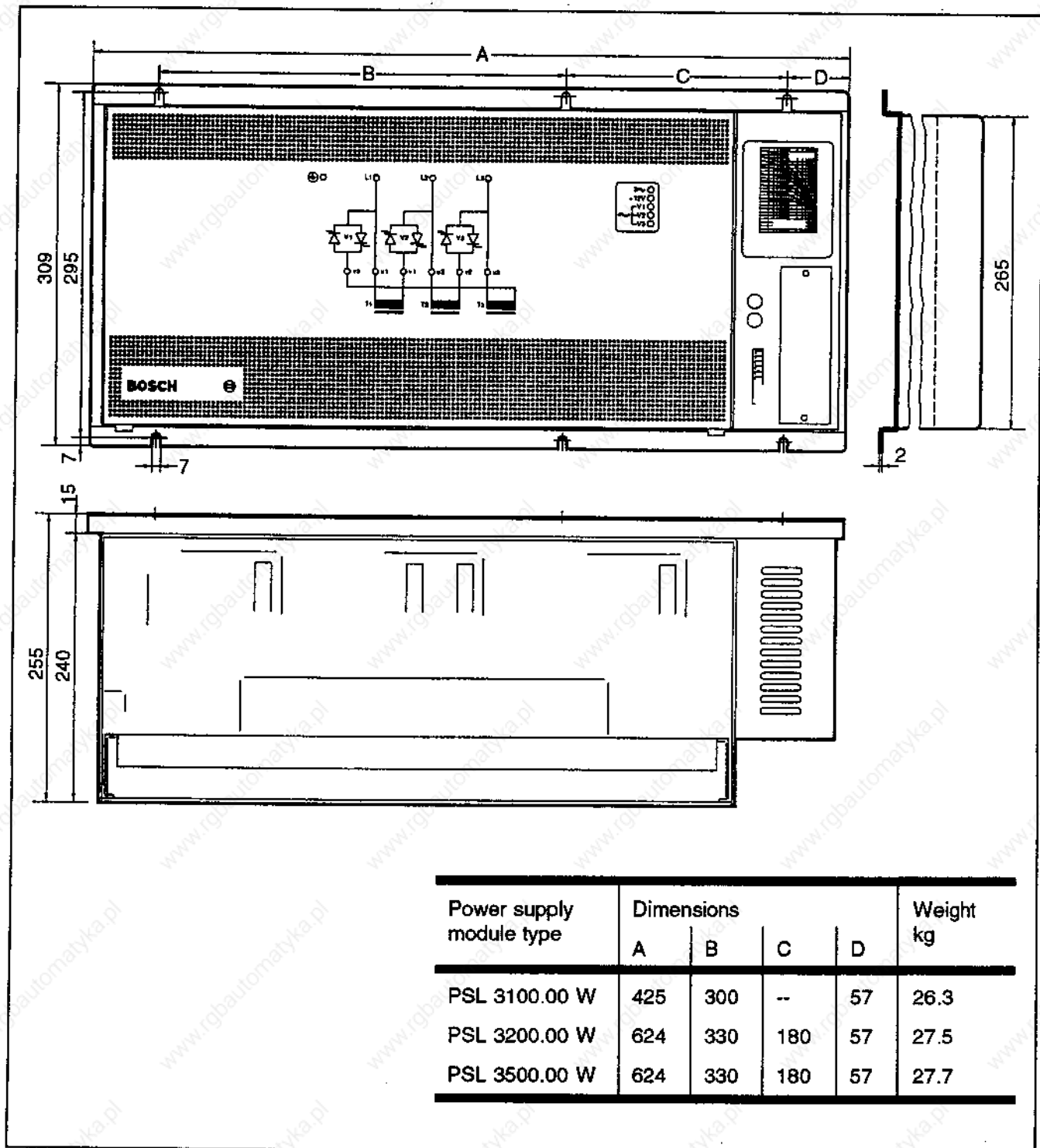
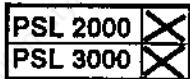

Fig. 3.5 Dimensions

**Power supply module
Type PSL 2000/3000**



4 Installation Instructions



The power supply modules are designed to be installed in switch cabinets or machine housings.

In any case it must be made sure that the space intended for installation is in accordance with the applicable regulations of the protection standards.



DANGER

The protection standard of PSL 2000/3000 is IP 00. Please note that "Shock protection covers" are available as accessories (see chapter 9).

The power supply module is best positioned on a mounting plate and fastened by means of bolts M 6. The corresponding dimensions for the fastening holes are shown in the "Dimensions" section.



NOTE

If the PSS... timer module is to be installed in the direct vicinity of the power supply module, then the timer module should be placed on the **right** hand side of the power supply module (see Fig. 4.1).

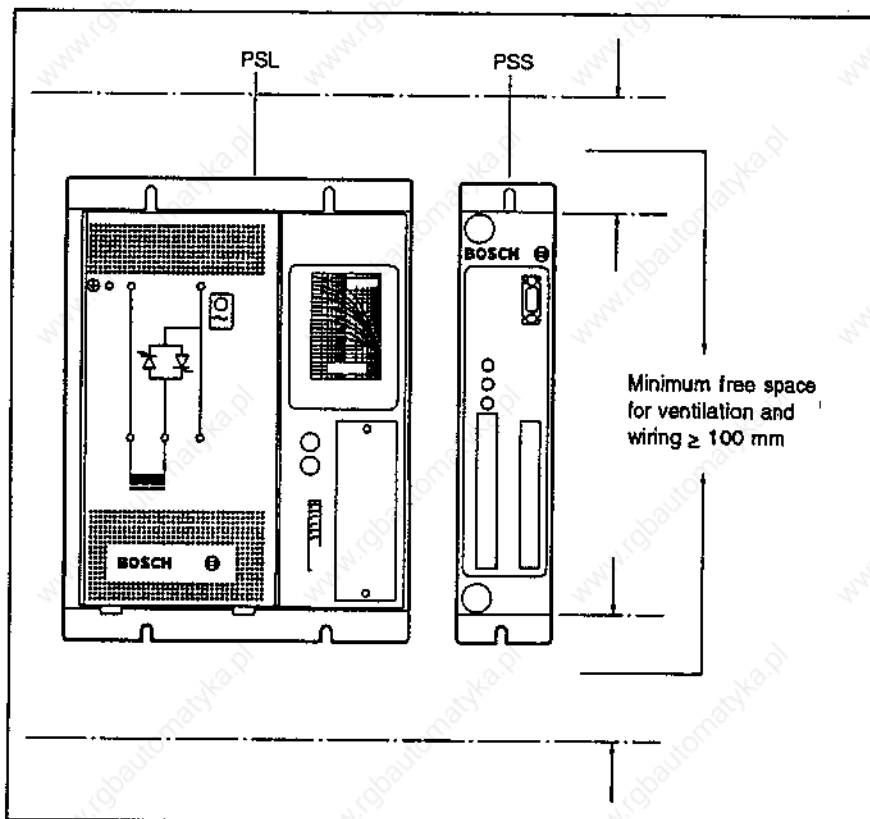

Fig. 4.1 Arrangement on the mounting plate



In order to make sure that the wiring for connecting the power supply module can be easily carried out, observe the necessary distance between the upper and lower module edge and the housing wall. We recommend keeping a min. distance of 100 mm each. In the case of smaller distances, there is danger of heat accumulation which may cause failures of the units.

If **air-cooled** power supply modules are used, it must be possible to dissipate the heat accumulated through power loss by means of the surrounding housing.

The power losses for different operating conditions are indicated in the power loss diagram (see Fig. 7.4). The max. air temperature in the housing must not exceed 55°C. The cooling effect of the surrounding housing must be checked.



ATTENTION

If **water-cooled** power supply modules are used, it must be made sure that, in the case of leaks in the cooling water system, leaking cooling water cannot damage other components (if necessary, provide for appropriate protection).

5 Connection Instructions



DANGER

Read and observe the safety instructions and switch off power switch before connecting to mains!

- Working with high voltages may result in death, severe bodily injury or considerable damage to property unless the appropriate precautions have been taken. Check the "Safety instructions" chapter (page 2) for the 5 components of the safety measures !
- Please note the connection diagram on the plexiglass cover. The plexiglass cover should be removed for making the connection.

5.1 Mains connection

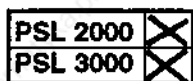

PSL 2000

- Protective earth conductor (PE) can only be connected from **above**
- Mains connection (L1/L2) can be made from **above** or from **below**

PSL 3000

- Protective earth conductor (PE) can only be connected from **above**
- Mains connection (L1/L2/L3) can only be made from **above**

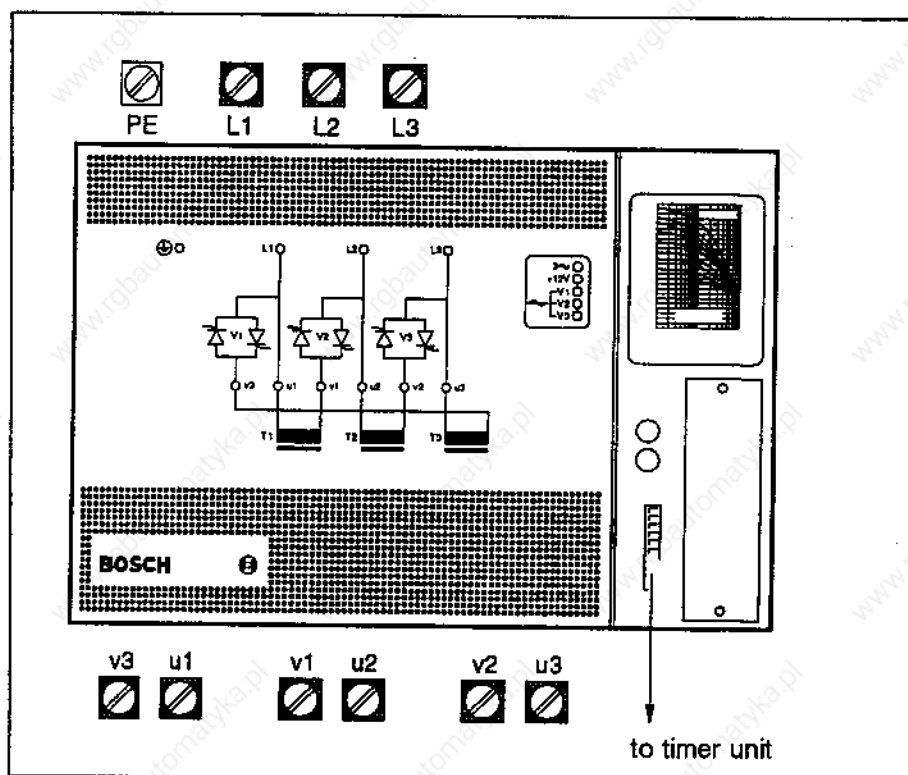

Fig. 5.1 Mains connection of PSL 3000

5.2 Transformer connection

The pin assignment of the power supply module is shown on the plexiglass cover. For convenient connection, the plexiglass cover should be removed.

PSL 2000	<input checked="" type="checkbox"/>
PSL 3000	<input type="checkbox"/>

PSL 2000

Connection is effected by means of cable lugs (not included in the delivery) for threaded bolts:

- M8 for PSL 2040.00 L/PSL 2100.00 W
- M12 for PSL 2200.00 W/PSL 2500.00 W

Pin assignment for transformer:

- Transformer T1: connection to u1/v1
- Protective earth conductor (PE) for transformer connected to separate earthing bar inside the switch cabinet.



NOTE

Make sure that the threaded joints are properly tightened. If necessary, hold onto other side with second wrench.

PSL 2000	<input type="checkbox"/>
PSL 3000	<input checked="" type="checkbox"/>

PSL 3000

Connection is effected by means of cable lugs (not included in the delivery) for threaded bolts:

- M8 for PSL 3100.00 W
- M12 for PSL 3200.00 W/PSL 3500.00 W

Pin assignment for transformers (see Fig. 5.1):

- Transformer T1: connection to u1/v1
- Transformer T2: connection to u2/v2
- Transformer T3: connection to u3/v3
- Protective earth conductor (PE) for transformer connected to separate earthing bar inside the switch cabinet.



NOTE

Make sure that the threaded joints are properly tightened. If necessary, hold onto other side with second wrench.

5.3 Water connection

PSL 2000	X
PSL 3000	X

Water connection is floating, it is made at the bottom side of the power supply module:

- water inlet at left-hand side
- water outlet at right-hand side
- external thread G 3/8"
- taper steps according to DIN 8542



ATTENTION

Prior to switching on the mains voltage, check threaded joints for tightness. Ensure required water flow rate. (See applicable technical data "Cooling".)

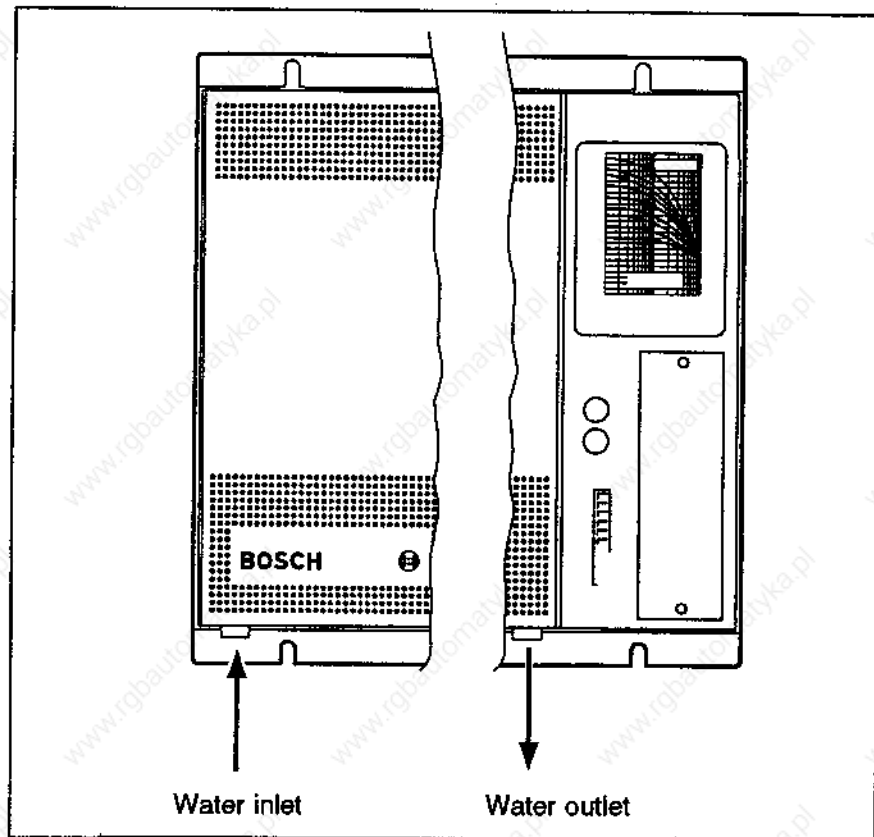
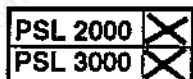

Fig. 5.2 Water connection

5.4 Connection to Timer Module, "X1" Terminal Connector



The following BOSCH timer modules can be connected to the PSL 2000/3000 power supply modules:

- PSS 2000 versions (standard)
- E...DYD versions
- PE...(ZPS) versions
- basically all timer types that receive their 27 V a.c. supply from the power and supply unit.

The connection between the power supply module and the timer module is made via terminal connector "X1". The connection cable is **not** included in the delivery.

- Connection is effected 1 to 1, i.e. terminal 1 of power supply module to terminal 1 of timer module.
- The connection must be a 10-pole connection (terminals included in delivery).

The required cross-section is:

- up to 10 m $\geq 1 \text{ mm}^2$
- up to 75 m $= 1.5 \text{ mm}^2$

The max. clampable wire cross-section is 1.5 mm^2 .



NOTE

Provide wire ends with end sleeves. Properly tighten the terminals.

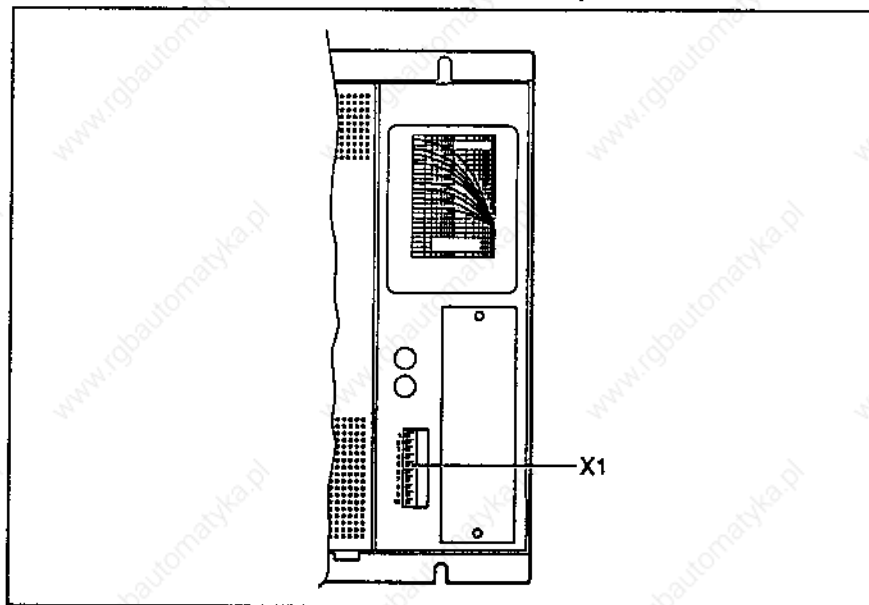

Fig. 5.3 "X1" terminal connector



The block diagram shown in Fig. 5.4 illustrates the principle of the circuit of the PSL 2000 power supply module.

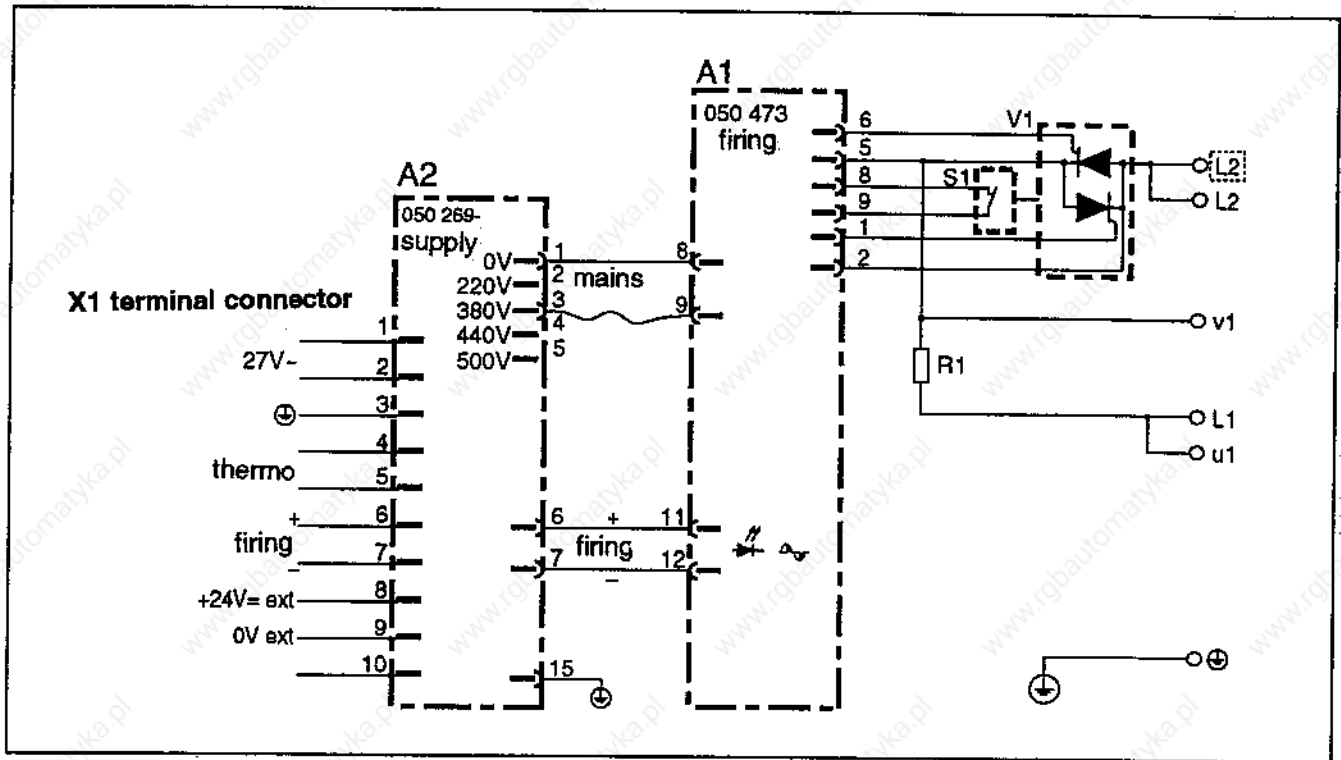

Fig. 5.4 Block diagram of PSL 2000

PSL 2000	
PSL 3000	X

The block diagram shown in Fig. 5.5 illustrates the principle of the circuit of the PSL 3000 power supply module. The jumper on the firing board must be changed over, depending on the timer module connected.

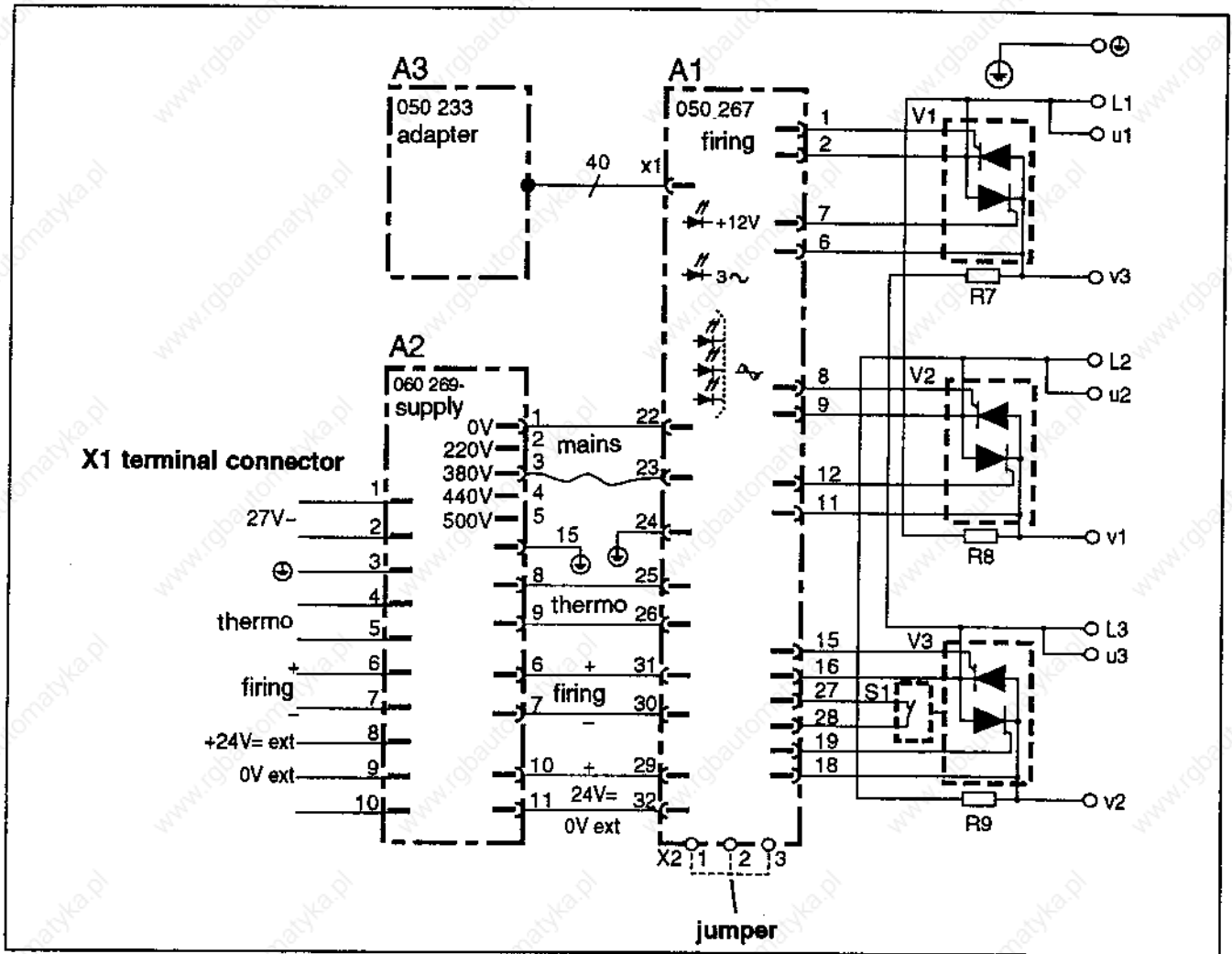

Fig. 5.5 Block diagram of PSL 3000

PSL 2000	
PSL 3000	X

With the PSL 3000 power supply module, the jumper on the firing board shown in Figs. 5.5 and 5.6 must be changed over, depending on the timer module connected.

- PSS 2000... jumper between x2/2 and x2/3
- E..DYD, PE... (ZPS) jumper between x2/1 and x2/2

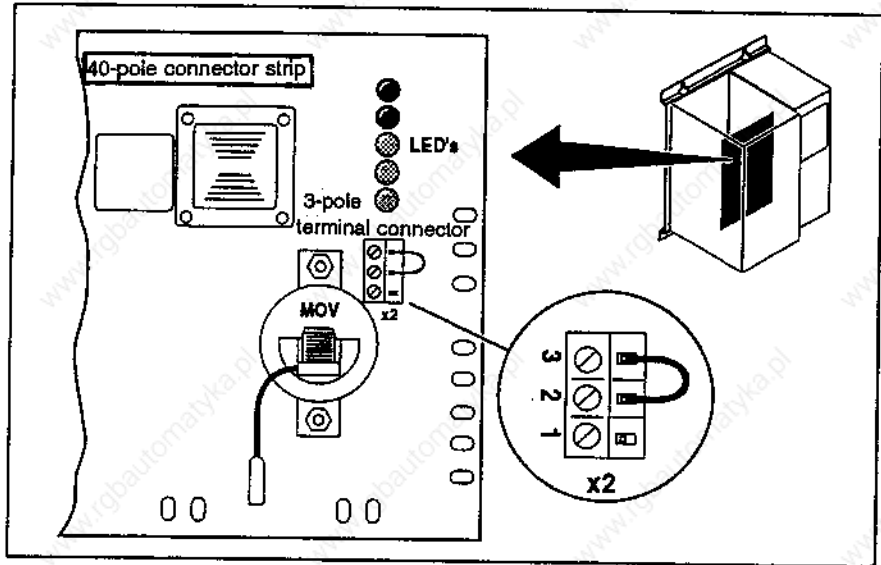

Fig. 5.6 Jumper on the firing board

5.4.1 Connection to timer modules type PSS 2000

PSL 2000	X
PSL 3000	X

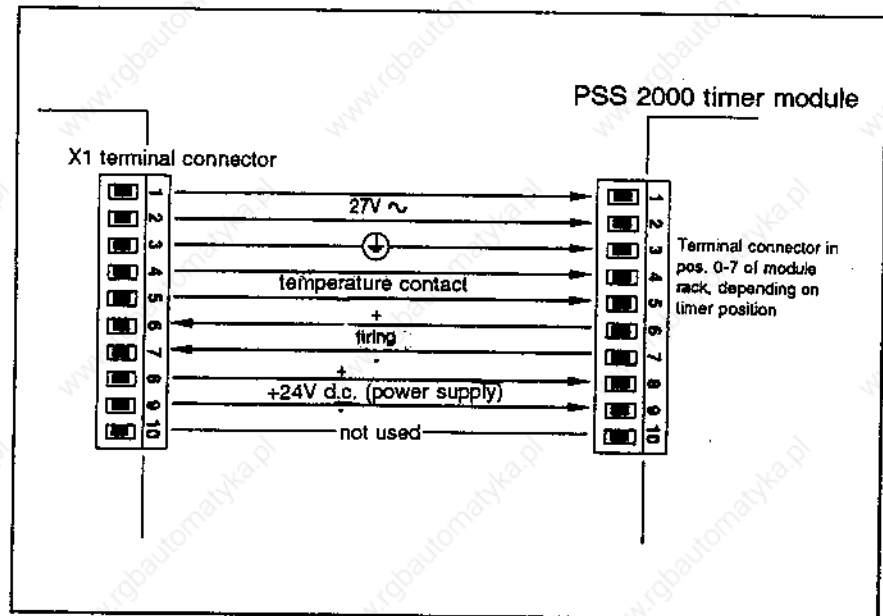

Fig. 5.7 Pin assignment

5.4.2 Connection to timer modules type E...DYG

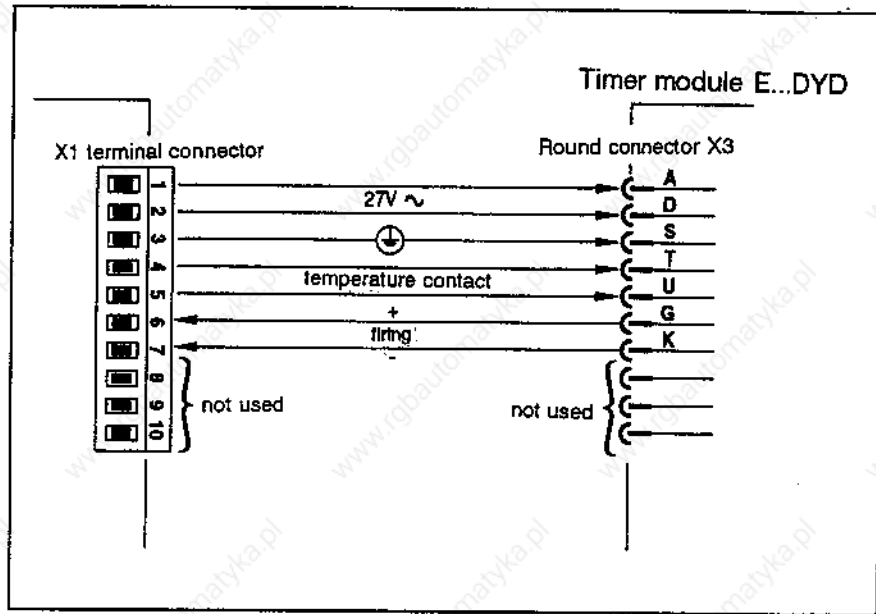
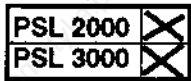

Fig. 5.8 Pin assignment

5.4.3 Connection to timer modules type PE... (ZPS)

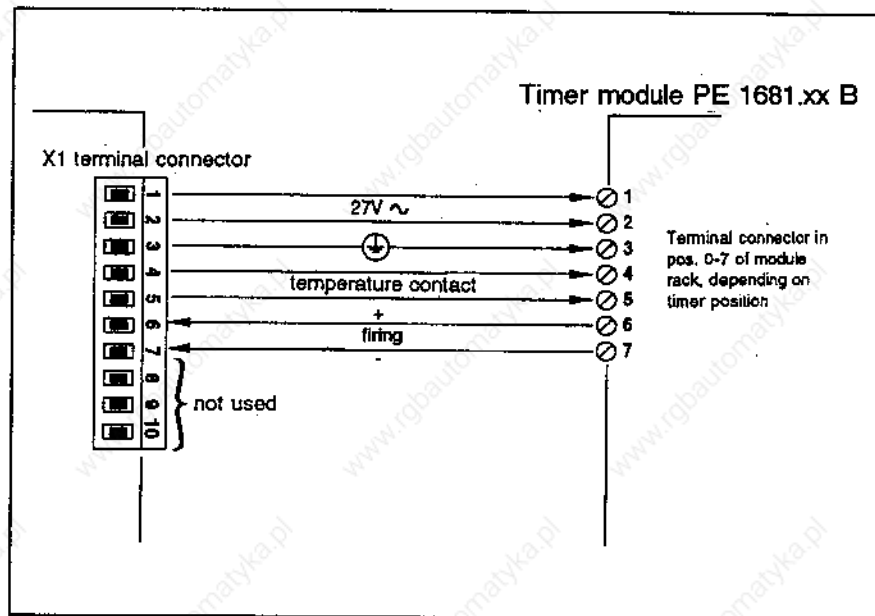
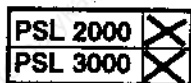

Fig. 5.9 Pin assignment

5.5 Mains Voltage Selection



When delivered, all power supply modules are set for a connected voltage of 380 V. If necessary, the customer can set the following voltages:

- 220 V
- 415 - 440 V
- 500 - 550 V

Admissible voltage variations: +15 %, -20 %.



DANGER

Make sure that the mains voltage is set when the unit is de-energized. Use insulated tools.

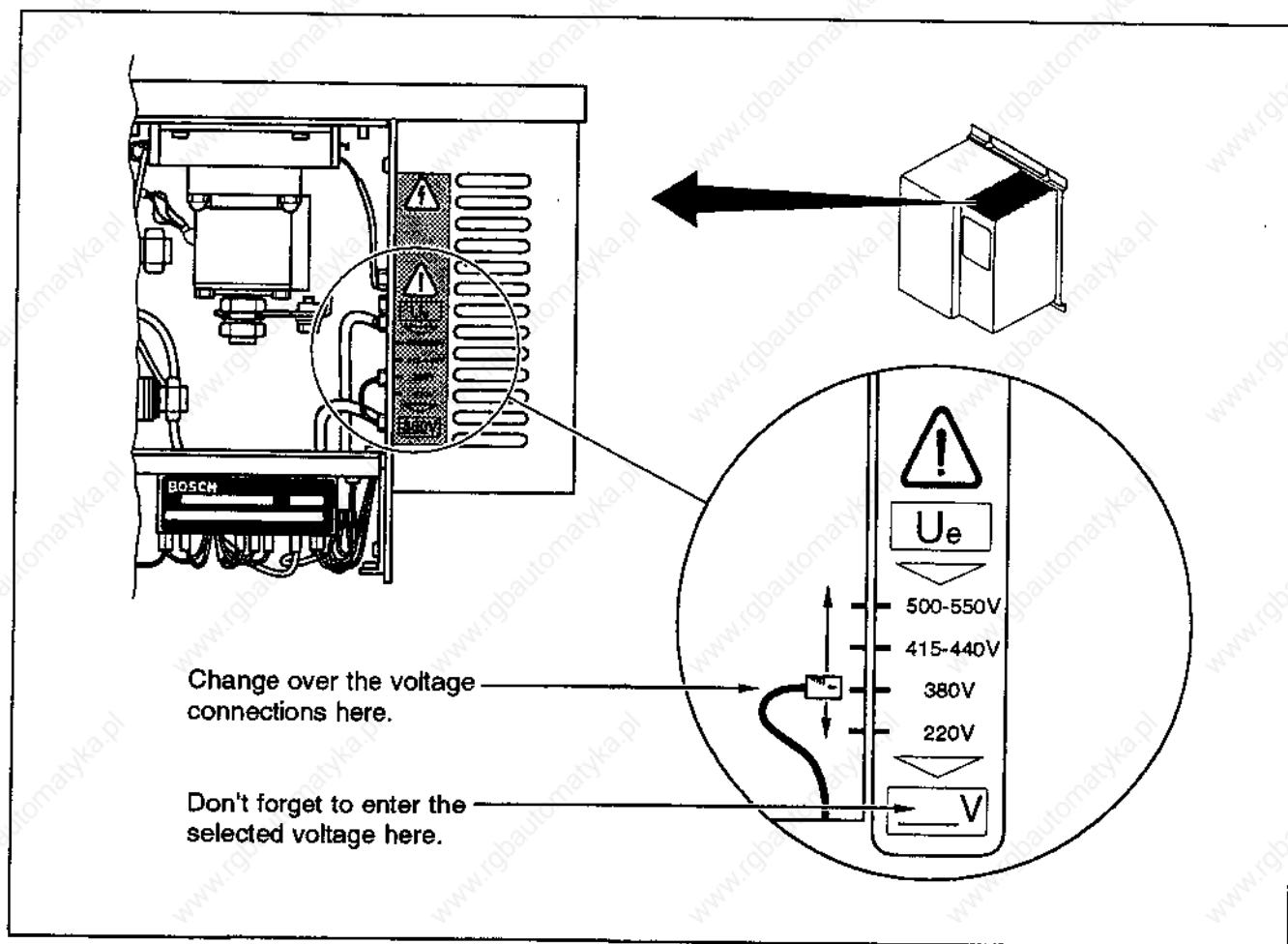
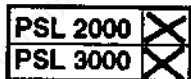

Fig. 5.10 Top view of power supply module

**Power supply module
Type PSL 2000/3000**



6 Maintenance



The power supply module is maintenance-free. However, a faulty connection can cause an activation of the protective fuses in the device. If necessary, these can be replaced by the customer himself (see Fig. 6.1 and Fig. 6.2).

Any other defects should be remedied by the manufacturer.

DANGER

Disconnect from mains before searching faults in the power supply module.
Caution! High voltage!

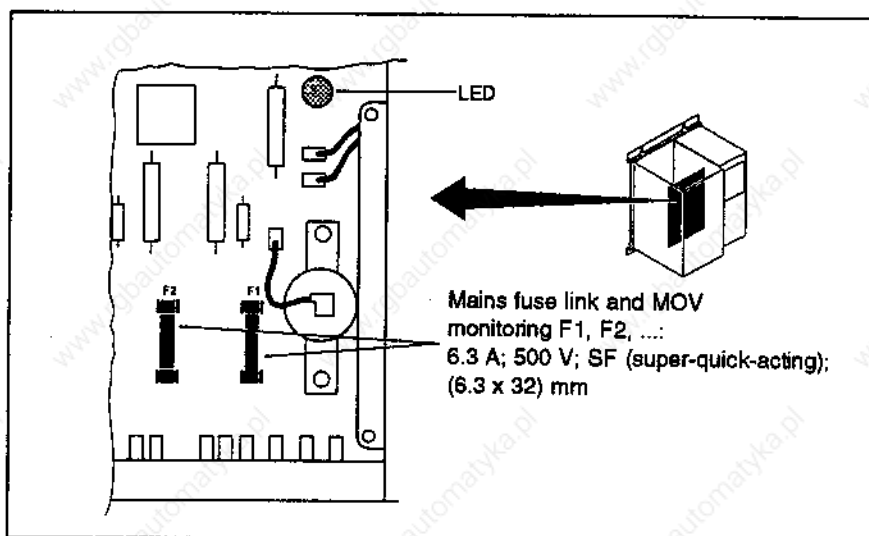

Fig. 6.1 Power supply module, firing board

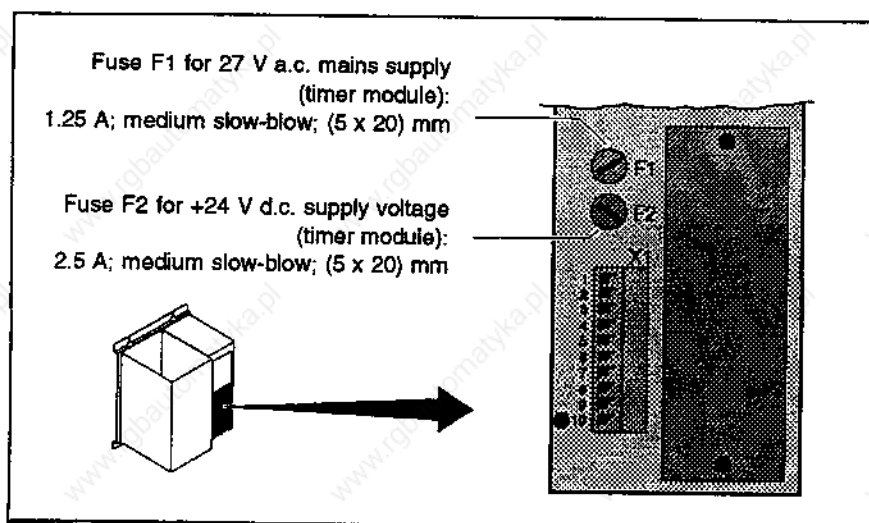

Fig. 6.2 Power supply module, "X1" terminal connector

Power supply module
Type PSL 2000/3000



7 Dimensioning Instructions

7.1 Load Diagram

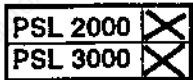

In principle, the load capacity of thyristors is predetermined by the type allocation to specified max. transformer sizes.

However, the actual load of the thyristor should be checked by the user in each specific case.

For this purpose, the load diagram, which is available for each individual thyristor, is used. This load diagram indicates the effective currents the thyristor is capable of switching as a function of the weld time and the duty cycle at max. cooling agent temperature (air or water) and minimal flow rate in the case of water.

Effective current	I_{RMS}	A
Weld time	t_s	cycle
Duty cycle	ED	%
Cooling agent temperature		°C
Cooling water flow rate		l/min

For determining the percentage duty cycle (ED), the weld time t_s and the weld cycle time t_{sp} must be known.

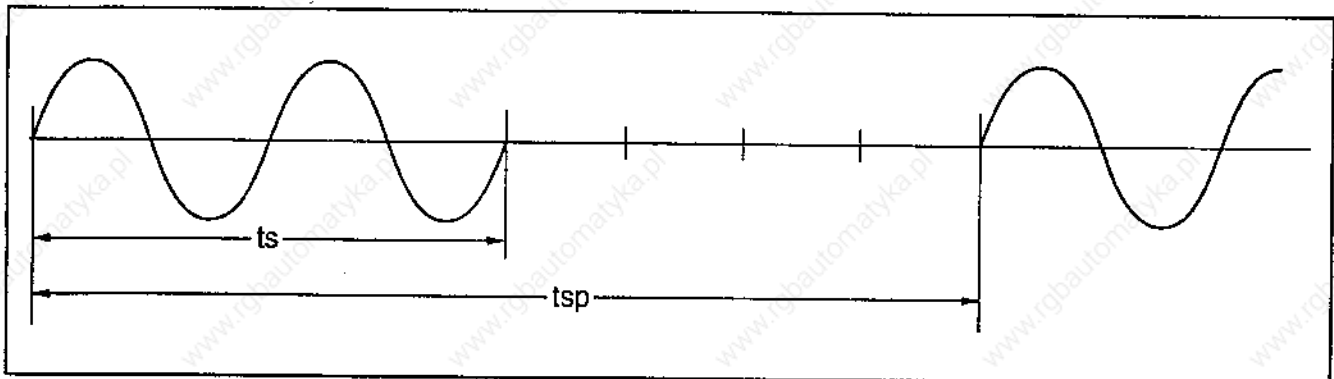

Fig. 7.1 Weld time and weld cycle time

The duty cycle (ED) is calculated as follows:

$$ED = \frac{t_s}{t_{sp}} \cdot 100 \%$$

Example Fig. 7.1: ($t_s = 2 \text{ cyc.}$, $t_{sp} = 4 \text{ cyc.}$) results in a duty cycle ED:

$$ED = \frac{2 \text{ cyc.}}{4 \text{ cyc.}} \cdot 100\% = 50 \%$$

If there are different weld times and cycle times at one welding station, the longest weld time and the shortest cycle time (if necessary, by adding the longest weld time and the shortest pause time) are to be used for calculating the ED.

After the duty cycle has been calculated, the load diagram can be used for checking the correct dimensioning of the thyristors.

Example 1:

Weld data of machine:

- Weld time t_w = 10 cyc.
- Duty cycle ED = 10 %
- Current I_{RMS} = 600 A

The intersection ED \rightarrow I_{RMS} found in the diagram for the PSL 2040 power supply module (Fig. 7.2) is still below the 10-cycle curve. This means that the thyristor is correctly dimensioned.

The dimensioning of other thyristors or power supply modules is verified analogously on the basis of the respective load diagrams.

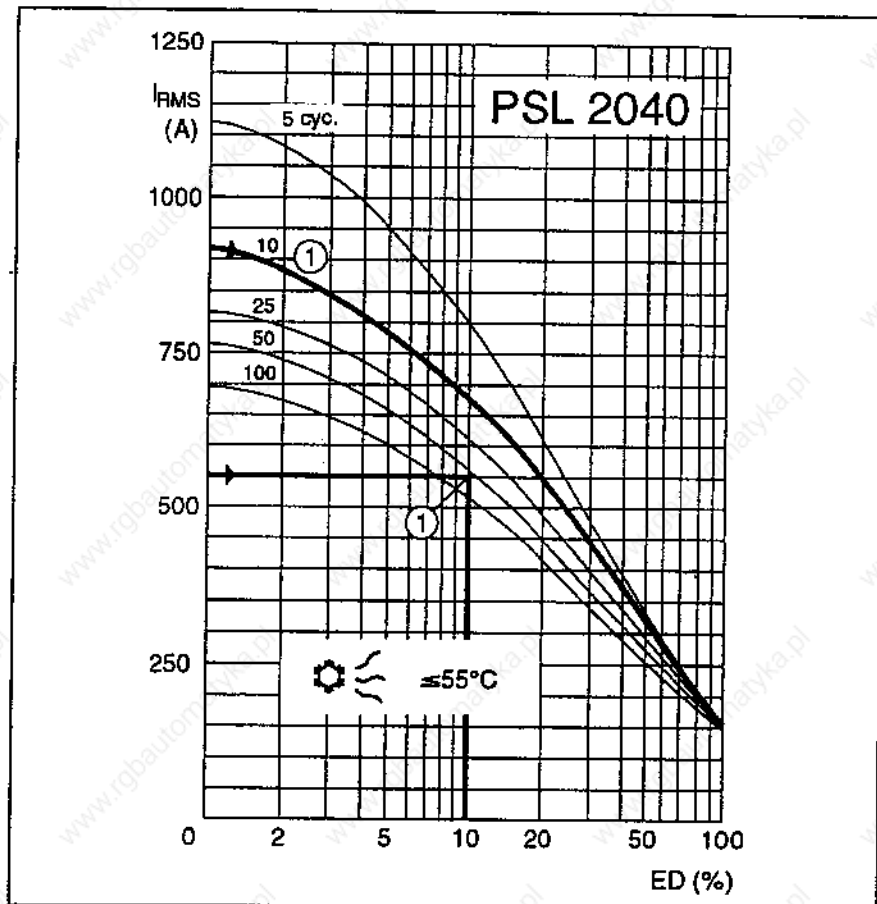

Fig. 7.2 Load diagram

Example 2:

Weld data of machine:

- Weld time t_w = 100 cyc.
- Duty cycle ED = 10 %
- Current I_{RMS} = 750 A

The intersection ED $\rightarrow I_{RMS}$ found in the diagram for the PSL 2040 power supply module (Fig. 7.3) is above the curve for 100 cycles. This means that the thyristor load is **too high**.



NOTE

Weld times ≥ 100 cycles are to be regarded as permanent current that should be read off at the 100% ED point of the load diagram.

The dimensioning of other thyristors or power supply modules is verified analogously on the basis of the respective load diagrams.

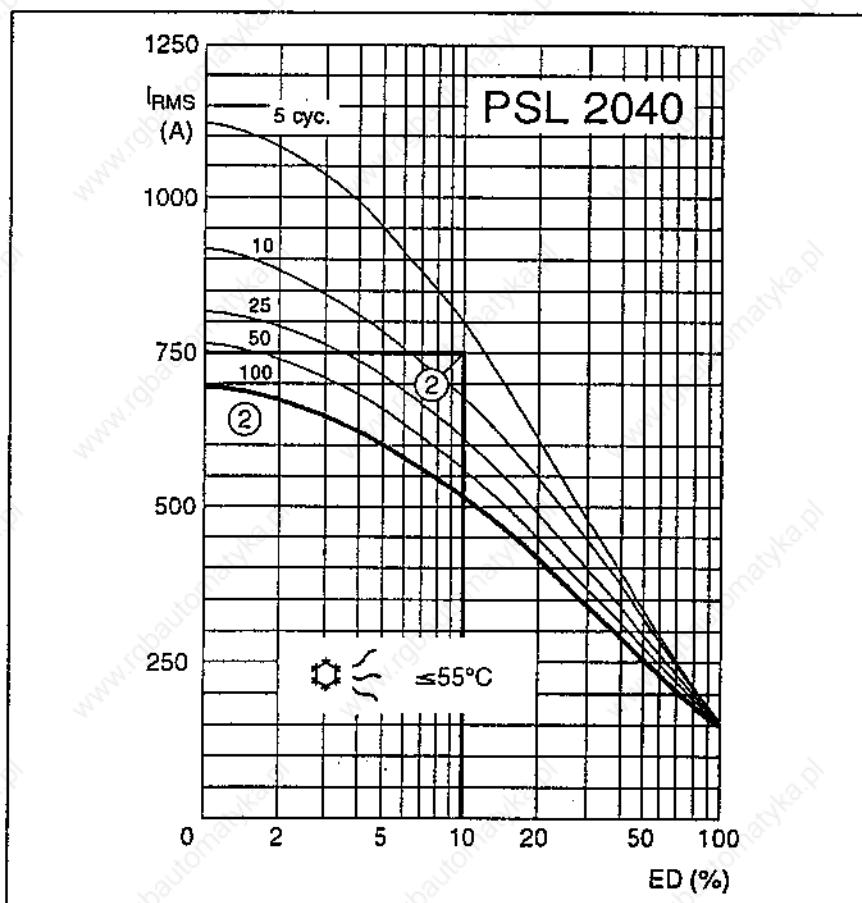

Fig. 7.3 Load diagram

7.2 Power Loss Diagram

PSL 2000	<input checked="" type="checkbox"/>
PSL 3000	<input type="checkbox"/>

In the case of **air-cooled** power supply units, the thyristors are cooled by a corresponding heat sink.

During this process, the effectiveness of cooling depends on the temperature of the ambient air. As an upper temperature limit, an ambient temperature of 55°C is assumed in the power loss diagram (as well as in the load diagram).

Depending on the thyristor load, then a higher heat-sink temperature occurs. By design, the max. heat-sink temperature is set to 80°C and must not be exceeded during operation, since otherwise the monitoring thermostat will switch off and it will not be possible to continue operation until further appropriate down-cooling has taken place.

In order to ensure that the max. heat-sink temperature is not reached, the power loss diagram shown in Fig. 7.4 is used. If the operating values of the duty cycle and the weld current are within the dotted range, a heat-sink temperature of 80°C will not be exceeded.

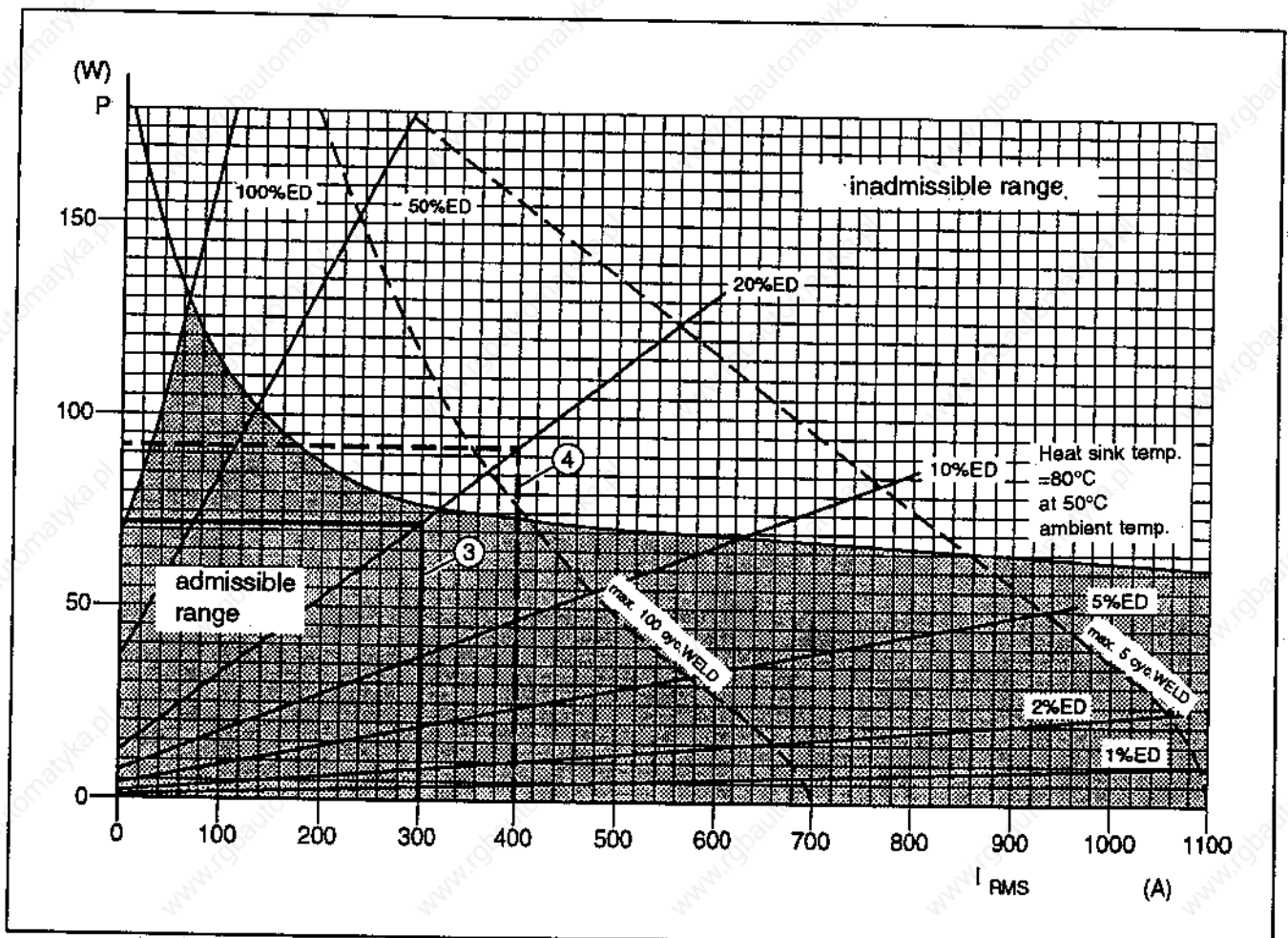

Fig. 7.4 Power loss diagram

The following examples serve to illustrate the application of the power loss diagram.

Example 3:

Weld data of the machine:

- Current $I_{RMS} = 300 \text{ A}$
- Duty cycle ED = 20 %

According to Fig. 7.4, the intersection ED $\rightarrow I_{RMS}$ is still within the admissible range.

Example 4:

Weld data of the machine:

- Current $I_{RMS} = 400 \text{ A}$
- Duty cycle ED = 20 %

According to Fig. 7.4, the intersection ED $\rightarrow I_{RMS}$ is within the inadmissible range, i.e. the heat-sink temperature is too high.

The power loss diagram can also be used for determining the overall power loss P_V (W) that occurs during operation in the power supply unit.

It is necessary to know the overall power loss for determining the air volume required for cooling (cabinet/housing size) or for heat exchangers.

Thus, the power loss under the operating conditions as shown in example 3 will be approx. 72 W. This power loss must be dissipated by the air cooling.

**Power supply module
Type PSL 2000/3000**



8 Fault messages

Extensive precautions were taken for protecting the thyristor block. These include, i.a., the following:

- temperature monitoring
- protective circuit against transient overvoltages

8.1 Temperature monitoring

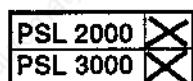

A bimetallic switch is located at the thyristor block which transmits a message to the BOSCH control valve in the case of overtemperature ($\geq 56^{\circ}\text{C}$). As a consequence, the BOSCH timer is inhibited, the ready signal at the timer goes off. The fault message "Power unit temperature fault" will be output.

Fault	Cause	Elimination
Power unit temperature fault	not enough cooling water	check water inlet and outlet
	thyristor rating too small	calculate duty cycle %, check thyristor characteristic

8.2 Protective circuit against transient overvoltages

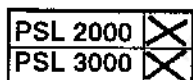

In order to prevent the thyristor from being destroyed by overvoltages, it is protected by an MOV (metal-oxide varistor). In the case of overvoltages in the mains (e.g. due to spurious peaks or pulses), the MOV acts as a protective diode, cutting off the peaks.

As a result, one of the fuses on the firing board connected in series (F1, F2, ...), depending on the phase relation, might melt.

Technical data of the fuse links:

- FF 6.3 A; 500V Size: (6.3 x 32) mm.

	DANGER
	Disconnect from mains before replacing fuses.
	Read and observe the safety instructions!
	Handling high voltages may involve death, severe bodily injury or considerable damage to property unless appropriate safety measures are taken.

LED display

PSL 2000	
PSL 3000	X

In case one of the MOV fuses of a 3-phase power supply unit melts, the fault message at the timer will be "Power unit temperature fault". The green LED "3~" on the firing board goes off.

The green LED "3 ~" goes off:

- if one of the 3 phases is missing,
- if the phase sequence (clockwise rotating phase sequence) is not correct.

LED displays and their interpretation (see Fig. 8.1):

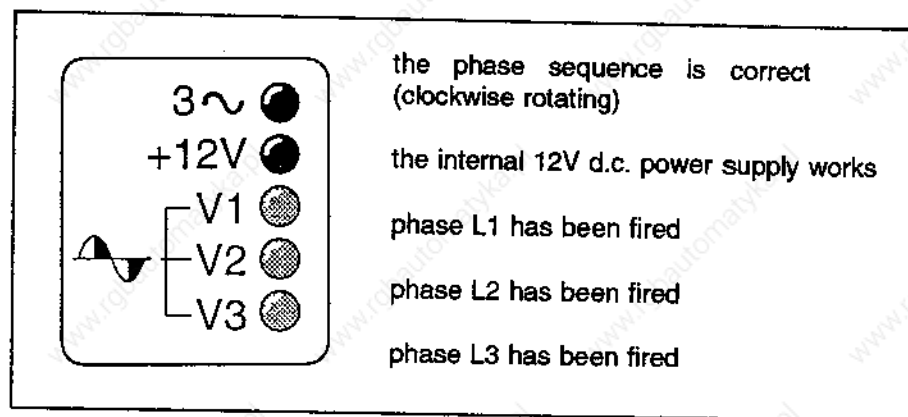
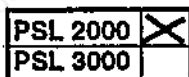

Fig. 8.1 LED display

9 Accessories

9.1 Water saving device



This is a device that reduces water consumption and prevents condensation.

The cooling water supply is controlled by a solenoid valve and a temperature sensor. The water saving device opens the cooling water inlet when $\geq 35^{\circ}\text{C}$ ($\pm 3^{\circ}\text{C}$) at the thyristor block are reached and closes the cooling water supply when the temperature is $\leq 25^{\circ}\text{C}$ ($\pm 4^{\circ}\text{C}$).

The use of the water saving device is advisable only if the welding equipment duty cycle is $\geq 25\%$ ED. BOSCH therefore recommends not to exceed the following values if the water saving device is used:

- max. 25% ED (duty cycle)
- ≤ 30 cycles weld time with respect to the specified permanent current of the thyristor.



NOTE

The water saving device is available as a retrofit kit and can be fitted by the customer in all power supply unit types PSL 2100 to PSL 2500.

Part number of the water saving device:

- PSZ 2021 Lg.Nr. 063 583

The delivery includes:

- 1 pce. solenoid valve no. 064 810
- 1 pce. thermostatic switch no. 064 813
- 1 pce. assembly instructions no. 064 814

DANGER



Disconnect the unit from mains and switch off the cooling water circuit prior to the retrofit works.

Read and observe the safety instructions!

- Handling high voltages may involve death, severe bodily injury or considerable damage to property unless appropriate safety measures are taken.

9.2 Shock-protection covers

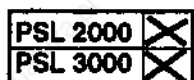

As an accessory, BOSCH offers shock-protection kits made of plexiglass. These kits are designed to protect users from contact with live high-voltage parts of the power supply modules and to prevent the ingress of foreign bodies.



NOTE

The protection standard of power supply modules equipped with shock-protection covers increases to IP20.

A shock-protection kit consists of two parts:

- upper shock-protection cover
- lower shock-protection cover

Openings for the cable connections are provided by means of cutouts which can be removed depending on the cable diameter and cable position.

The screws of the plexiglass front plate are used for fastening the covers to the power supply modules (see Fig. 9.1 and Fig. 9.2). Detailed mounting instructions will be provided together with the shock-protection kits.

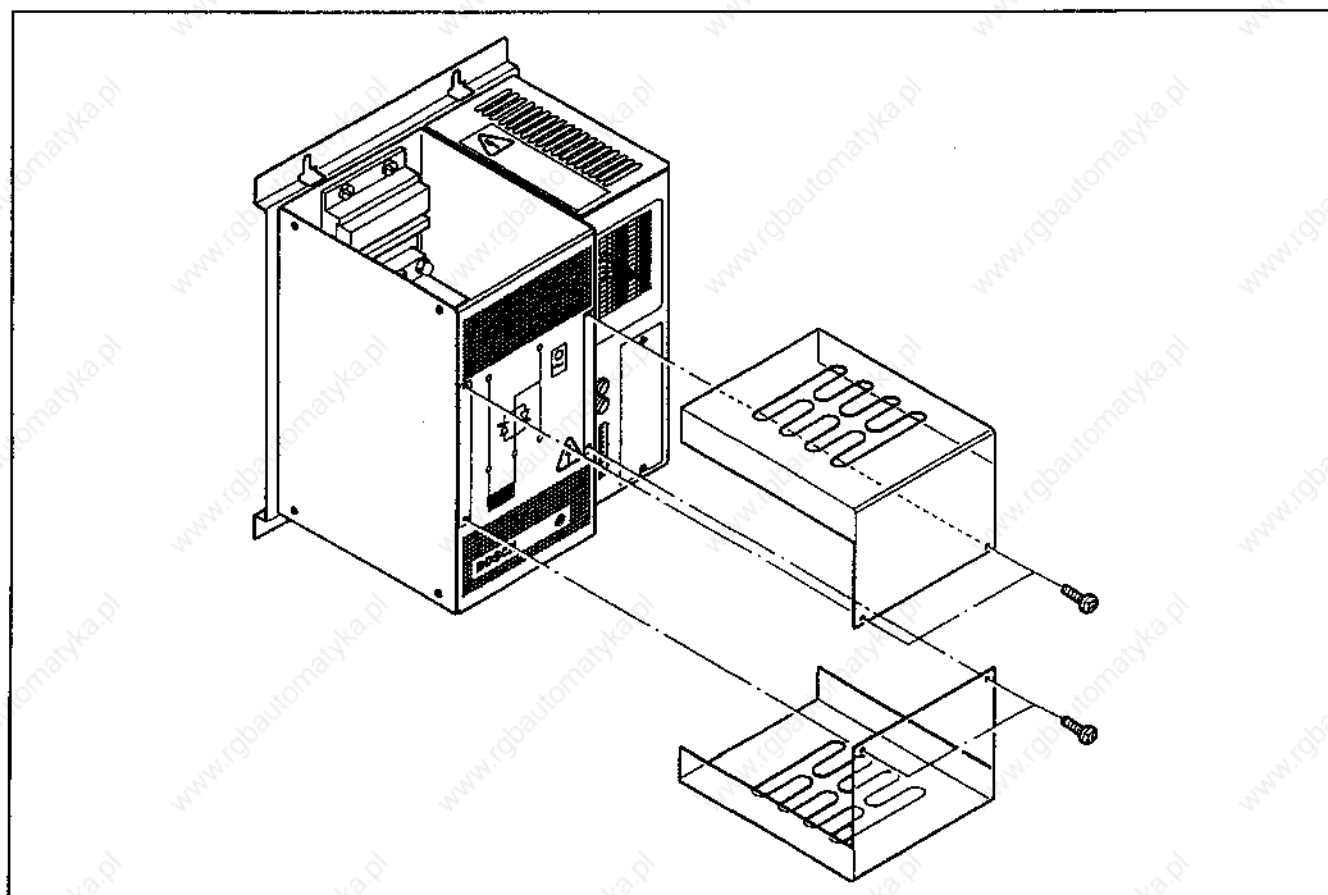

Fig. 9.1 PSL 2000 Shock-protection covers

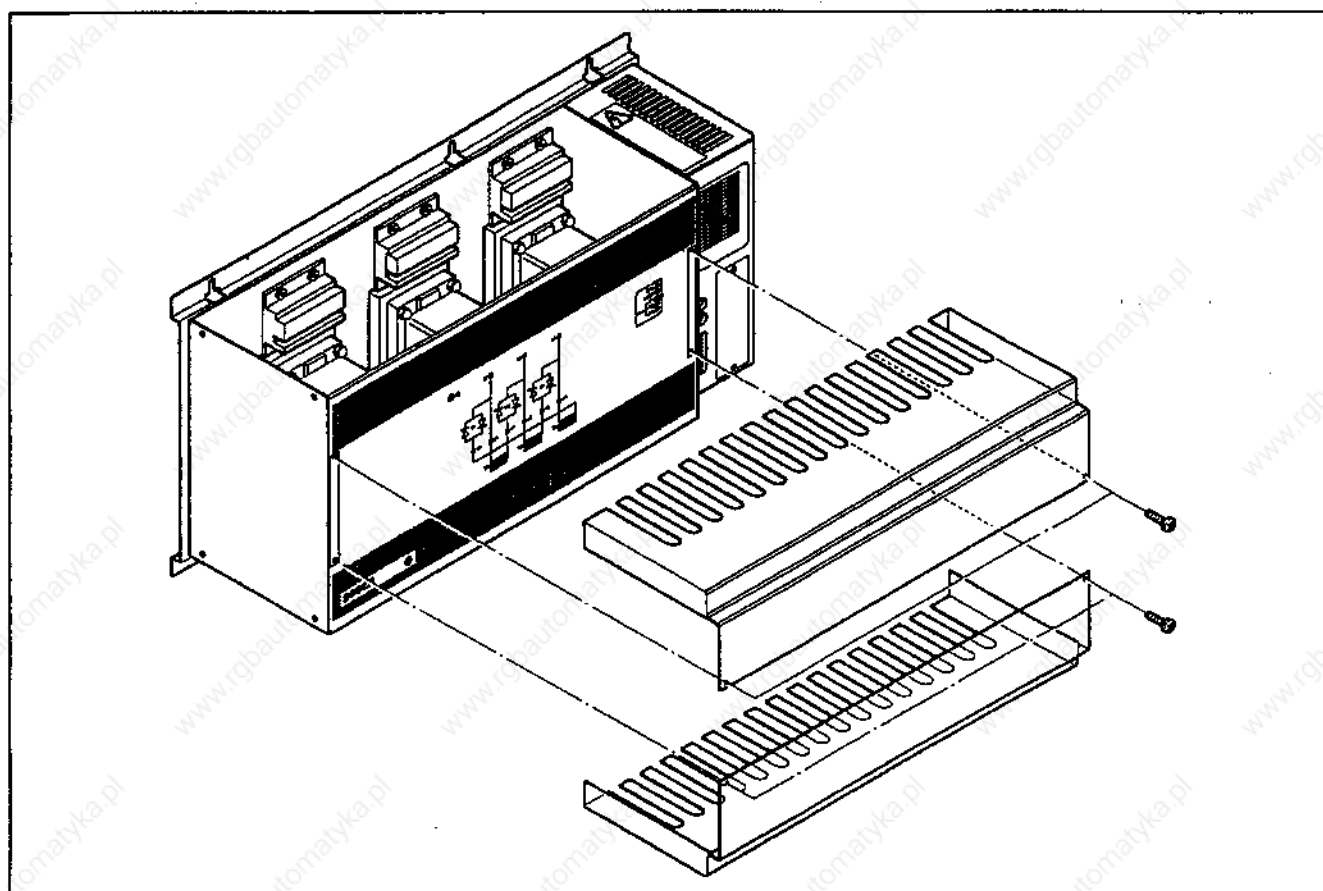

Fig. 9.2 PSL 3000 Shock-protection covers

Part numbers of shock-protection kits:

Power supply module type	Shock-protection cover	Part number
PSL 2040.00 L PSL 2100.00 W	PSB 40/100	064 088
PSL 2200.00 W PSL 2500.00 W	PSB 200/500	064 030
PSL 3100.00 W	PSB 310	063 609
PSL 3200.00 W PSL 3500.00 W	PSB 320/350	063 609

