

Rexroth IndraControl L40

R911308429
Edition 03

Project Planning Manual



Title	Rexroth IndraControl L40
Type of Documentation	Project Planning Manual
Document Typecode	DOK-CONTRL-IC*L40*****-PR03-EN-P
Internal File Reference	Document Number, 120-0401-B321-03/EN
Purpose of Documentation	This documentation describes the hardware of control IndraControl L40.

Record of Revisions

Description	Release Date	Notes
120-0401-B321-02/EN	10/04	First English Edition
120-0401-B321-03/EN	02/07	Third Edition

Copyright © 2007 Bosch Rexroth AG

Copying this document, giving it to others and the use or communication of the contents thereof without express authority, are forbidden. Offenders are liable for the payment of damages. All rights are reserved in the event of the grant of a patent or the registration of a utility model or design (DIN 34-1).

Validity The specified data is for product description purposes only and may not be deemed to be guaranteed unless expressly confirmed in the contract. All rights are reserved with respect to the content of this documentation and the availability of the product.

Published by Bosch Rexroth AG
Bgm.-Dr.-Nebel-Str. 2 • D-97816 Lohr a. Main
Telephone +49 (0)93 52/40-0 • Tx 68 94 21 • Fax +49 (0)93 52/40-48 85
<http://www.boschrexroth.com/>
Dept. BRC/EPY (NH)

Note This document has been printed on chlorine-free bleached paper.

Contents

1	System Presentation	1-1
1.1	Brief Description of the IndraControl L40	1-1
1.2	View	1-1
1.3	Related Documentations	1-2
2	Important Directions for Use	2-1
2.1	Appropriate Use	2-1
	Introduction	2-1
	Areas of Use and Application	2-2
2.2	Inappropriate Use	2-2
3	Safety Instructions for Electric Drives and Controls	3-1
3.1	Introduction	3-1
3.2	Explanations	3-1
3.3	Hazards by Improper Use	3-2
3.4	General Information	3-3
3.5	Protection Against Contact with Electrical Parts	3-4
3.6	Protection Against Electric Shock by Protective Low Voltage (PELV)	3-5
3.7	Protection Against Dangerous Movements	3-6
3.8	Protection Against Magnetic and Electromagnetic Fields During Operation and Mounting	3-7
3.9	Protection Against Contact with Hot Parts	3-8
3.10	Protection During Handling and Mounting	3-8
3.11	Battery Safety	3-9
3.12	Protection Against Pressurized Systems	3-9
4	Technical Data	4-1
4.1	Equipment	4-1
4.2	Power Supply	4-1
4.3	Ambient Conditions	4-2
4.4	Used Standards	4-3
4.5	Compatibility Test	4-4
5	Dimensions	5-1
5.1	Housing Dimensions	5-1

6	Display and Operating Components	6-1
6.1	Display and Operating Keys	6-1
6.2	Reset Button and Light-Emitting Diode	6-2
7	Connections and Interfaces	7-1
7.1	Overview of Connections on the Front	7-1
7.2	Voltage Supply	7-2
	External Supply Voltages	7-2
	Internally Generated Voltages	7-6
7.3	Digital Inputs and Outputs	7-7
	Address Assignment of Inputs and Outputs	7-7
	Digital Onboard Inputs	7-8
	Digital Outputs	7-9
7.4	Interfaces	7-12
	Serial RS232 Interface	7-12
	Ethernet Interface	7-13
	PROFIBUS DP (Optional)	7-14
	SERCOS (Optional)	7-15
	Ready Contact (Optional)	7-15
	Interface for Compact Flash Card	7-16
7.5	Inline Bus	7-16
7.6	Function Modules	7-17
	Overview	7-17
	Technical Data	7-17
	CFL01.1-Y1 SRAM Function Module	7-19
	CFL01.1-V1 DeviceNet Master Function Module	7-21
	CFL01.1-P1 Profibus DP Master Function Module	7-23
	CFL01.1-R3 SERCOS III Function Module	7-25
	CFL01.1-Q2 Cross Communication Function Module	7-26
	CFL01.1-E2 Fast I/O Function Module	7-27
	CFL01.1-N1 Cam Switch Function Module	7-33
8	Installation and Maintenance	8-1
8.1	Mechanical Installation of the IndraControl L40	8-1
	Mounting the IndraControl L40	8-1
	Dismounting the IndraControl L40	8-3
8.2	Mechanical Installation of Rexroth Inline Modules	8-5
	Mounting the Inline Modules	8-5
	Dismounting the Inline Modules	8-6
	Fuse Replacement	8-7
8.3	Electric Installation	8-9
	External Power Supply Unit	8-9
	24 V Voltage Supply	8-10
	Main Switch and Fuses	8-14
	Ground Connection	8-15

Shielding	8-15
Connecting Lines to Tension Spring Connection Points	8-18
8.4 Maintenance	8-20
9 Structure of the Rexroth Inline Terminals	9-1
9.1 Basic Structure of Terminals of the Low Signal Level	9-1
9.2 Electronic Socket	9-1
9.3 Connectors	9-2
9.4 Identification of Function and Labeling	9-5
9.5 Housing Dimensions of the Modules of the Low Signal Level	9-8
9.6 Electrical Voltage and Data Routing	9-11
9.7 Electric Circuits and Voltage Supply Within a Rexroth Inline Station	9-12
9.8 Diagnostic and Status Indicators	9-13
Indicators on the IndraControl L40	9-13
Indicators on the Supply Terminals	9-15
Indicators on the Input/Output Modules	9-16
Indicators on Other Inline Modules	9-16
10 Disposal and Environmental Protection	10-1
10.1 Disposal	10-1
Products	10-1
Packaging Materials	10-1
10.2 Environmental Protection	10-1
No Release of Hazardous Substances	10-1
Materials Contained in the Products	10-1
Recycling	10-2
11 Ordering Information	11-1
11.1 Type Code	11-1
11.2 Accessories	11-4
Necessary Accessories (Connector Set)	11-4
Additional Accessories (Blower, Function Modules, Inline Modules and Interface Cables)	11-4
12 List of Figures	12-1
13 Index	13-1
14 Service & Support	14-1
14.1 Helpdesk	14-1
14.2 Service-Hotline	14-1
14.3 Internet	14-1
14.4 Vor der Kontaktaufnahme... - Before contacting us... ..	14-1
14.5 Kundenbetreuungsstellen - Sales & Service Facilities	14-2

1 System Presentation

1.1 Brief Description of the IndraControl L40

The IndraControl L40 is a modular and scalable control. It combines the benefits of an embedded-PC architecture with a standardized I/O system on the basis of terminal technology. It is a universal hardware platform that can be used for motion-logic and PLC applications. The hardware is available in system-specific versions (e.g. with/without SERCOS interface). It provides onboard interfaces, e.g. high-speed inputs and outputs (8 each) and communication interfaces, such as Ethernet, PROFIBUS, RS232 and SERCOS. Via the integrated PCI bus, additional modules permit the extension of the IndraControl L40 by additional field bus and technology interfaces, such as DeviceNet and master axis encoder interfaces. The locally available I/O units can be extended by the Rexroth Inline I/O system, just by simply mounting the components side by side. Application programs, inclusive runtime, are completely stored to an easily accessible standardized compact flash medium.

1.2 View

Operating elements and interfaces are arranged on the front.

The eight-digit display with four operator keys, the reset button with light-emitting diode, the RS232 interface, and the receptacle for the compact flash card are provided to the left of the unit. Depending on the design further interfaces (Ethernet, PROFIBUS DP, SERCOS, ready contact) are located in the central section of the unit. The terminals for digital inputs and outputs (eight each) and the voltage supply connectors are arranged to the right of the unit.



PST2376_02R.tif

Fig. 1-1: Front view of an IndraControl L40

1.3 Related Documentations

No.	Title	Identification
/1/	PLC Programming with Rexroth IndraLogic; Operating and Programming Guide	DOK-CONTRL-IL**PRO*V02-AW...-EN-P
/2/	Rexroth Inline PROFIBUS DP; Application Manual	DOK-CONTRL-R-IL*PBSSYS-AW...-EN-P
/3/	Rexroth Inline PROFIBUS DP Terminal and Module Supply; Functional Description	DOK-CONTRL-R-IL*PB*-BK-FK...-EN-P
/4/	Rexroth IndraWorks Engineering; Operating and Programming Guide	DOK-IWORKS-ENGINEE*V...-AW...-EN-P
/5/	Rexroth WinStudio; Overall View and Functional Description	DOK-CONTRL-WIS*PC**V06-KB...-EN-P
/6/	Automation terminals of the Rexroth Inline product family (in preparation)	DOK-CONTRL-ILSYSINS***-AW...-EN-P

Fig. 1-2: Related documentations

2 Important Directions for Use

2.1 Appropriate Use

Introduction

Rexroth products represent state-of-the-art developments and manufacturing. They are tested prior to delivery to ensure operating safety and reliability.

The products may only be used in the manner that is defined as appropriate. If they are used in an inappropriate manner, then situations can develop that may lead to property damage or injury to personnel.

Note: Bosch Rexroth, as manufacturer, is not liable for any damages resulting from inappropriate use. In such cases, the guarantee and the right to payment of damages resulting from inappropriate use are forfeited. The user alone carries all responsibility of the risks.

Before using Rexroth products, make sure that all the pre-requisites for appropriate use of the products are satisfied:

- Personnel that in any way, shape or form uses our products must first read and understand the relevant safety instructions and be familiar with appropriate use.
- If the product takes the form of hardware, then they must remain in their original state, in other words, no structural changes are permitted. It is not permitted to decompile software products or alter source codes.
- Do not mount damaged or faulty products or use them in operation.
- Make sure that the products have been installed in the manner described in the relevant documentation.

Areas of Use and Application

The IndraControl L40 of Rexroth is in equal measure appropriate to logic and motion applications.

Note: The IndraControl L40 may only be used with the accessories and parts specified in this document. If a component has not been specifically named, then it may not be either mounted or connected. The same applies to cables and lines.

Operation is only permitted in the specified configurations and combinations of components using the software and firmware as specified in the relevant function descriptions.

In case of non-observance the warranty claim expires automatically.

Typical applications of the IndraControl L40 are:

- Handling and assembly systems,
- Packaging and foodstuff machine,
- Printing and paper processing machines and
- Machine tools.

The IndraControl L40 may only be operated under the assembly, installation and ambient conditions as described here (temperature, system of protection, humidity, EMC requirements, etc.) and in the position specified.

In residential areas as well as in business and commercial areas Class A devices may be used with the following note:

Note: This is a Class A device. In a residential area, this device may cause radio interferences. In such a case, the user may be required to introduce suitable countermeasures at his own cost.

2.2 Inappropriate Use

Using the IndraControl L40 outside of the above-referenced areas of application or under operating conditions other than described in the document and the technical data specified is defined as "inappropriate use".

The IndraControl L40 may not be used, if

- it is subject to operating conditions that do not meet the above specified ambient conditions. This includes, for example, operation under water, in the case of extreme temperature fluctuations or extremely high maximum temperatures, or if
- Bosch Rexroth has not specifically released them for that intended purpose. Please note the specifications outlined in the general Safety Guidelines!

3 Safety Instructions for Electric Drives and Controls

3.1 Introduction

Read these instructions before the initial startup of the equipment in order to eliminate the risk of bodily harm or material damage. Follow these safety instructions at all times.

Do not attempt to install or start up this equipment without first reading all documentation provided with the product. Read and understand these safety instructions and all user documentation of the equipment prior to working with the equipment at any time. If you do not have the user documentation for your equipment, contact your local Bosch Rexroth representative to send this documentation immediately to the person or persons responsible for the safe operation of this equipment.

If the equipment is resold, rented or transferred or passed on to others, then these safety instructions must be delivered with the equipment.



WARNING

Improper use of this equipment, failure to follow the safety instructions in this document or tampering with the product, including disabling of safety devices, may result in material damage, bodily harm, electric shock or even death!

3.2 Explanations

The safety instructions describe the following degrees of hazard seriousness in compliance with ANSI Z535. The degree of hazard seriousness informs about the consequences resulting from non-compliance with the safety instructions.



Warning symbol with signal word	Degree of hazard seriousness according to ANSI
 DANGER	Death or severe bodily harm will occur.
 WARNING	Death or severe bodily harm may occur.
 CAUTION	Bodily harm or material damage may occur.

Fig. 3-1: Hazard classification (according to ANSI Z535)

3.3 Hazards by Improper Use



DANGER

**High voltage and high discharge current!
Danger to life or severe bodily harm by electric shock!**



DANGER

Dangerous movements! Danger to life, severe bodily harm or material damage by unintentional motor movements!



WARNING

High electrical voltage due to wrong connections! Danger to life or bodily harm by electric shock!



WARNING

Health hazard for persons with heart pacemakers, metal implants and hearing aids in proximity to electrical equipment!



CAUTION

Surface of machine housing could be extremely hot! Danger of injury! Danger of burns!



CAUTION

Risk of injury due to improper handling! Bodily harm caused by crushing, shearing, cutting and mechanical shock or incorrect handling of pressurized systems!



CAUTION

Risk of injury due to incorrect handling of batteries!

3.4 General Information

- Bosch Rexroth AG is not liable for damages resulting from failure to observe the warnings provided in this documentation.
- Read the operating, maintenance and safety instructions in your language before starting up the machine. If you find that you cannot completely understand the documentation for your product, please ask your supplier to clarify.
- Proper and correct transport, storage, assembly and installation as well as care in operation and maintenance are prerequisites for optimal and safe operation of this equipment.
- Only persons who are trained and qualified for the use and operation of the equipment may work on this equipment or within its proximity.
 - The persons are qualified if they have sufficient knowledge of the assembly, installation and operation of the equipment as well as an understanding of all warnings and precautionary measures noted in these instructions.
 - Furthermore, they must be trained, instructed and qualified to switch electrical circuits and equipment on and off in accordance with technical safety regulations, to ground them and to mark them according to the requirements of safe work practices. They must have adequate safety equipment and be trained in first aid.
- Only use spare parts and accessories approved by the manufacturer.
- Follow all safety regulations and requirements for the specific application as practiced in the country of use.
- The equipment is designed for installation in industrial machinery.
- The ambient conditions given in the product documentation must be observed.
- Use only safety features and applications that are clearly and explicitly approved in the Project Planning Manual.
For example, the following areas of use are not permitted: construction cranes, elevators used for people or freight, devices and vehicles to transport people, medical applications, refinery plants, transport of hazardous goods, nuclear applications, applications sensitive to high frequency, mining, food processing, control of protection equipment (also in a machine).
- The information given in the documentation of the product with regard to the use of the delivered components contains only examples of applications and suggestions.
The machine and installation manufacturer must
 - make sure that the delivered components are suited for his individual application and check the information given in this documentation with regard to the use of the components,
 - make sure that his application complies with the applicable safety regulations and standards and carry out the required measures, modifications and complements.
- Startup of the delivered components is only permitted once it is sure that the machine or installation in which they are installed complies with the national regulations, safety specifications and standards of the application.
- Technical data, connections and operational conditions are specified in the product documentation and must be followed at all times.

- Operation is only permitted if the national EMC regulations for the application are met.
The instructions for installation in accordance with EMC requirements can be found in the documentation "EMC in Drive and Control Systems".
The machine or installation manufacturer is responsible for compliance with the limiting values as prescribed in the national regulations.

3.5 Protection Against Contact with Electrical Parts

Note: This section refers to equipment and drive components with voltages above 50 Volts.

Touching live parts with voltages of 50 Volts and more with bare hands or conductive tools or touching ungrounded housings can be dangerous and cause electric shock. In order to operate electrical equipment, certain parts must unavoidably have dangerous voltages applied to them.



DANGER

High electrical voltage! Danger to life, severe bodily harm by electric shock!

- ⇒ Only those trained and qualified to work with or on electrical equipment are permitted to operate, maintain or repair this equipment.
 - ⇒ Follow general construction and safety regulations when working on high voltage installations.
 - ⇒ Before switching on power the ground wire must be permanently connected to all electrical units according to the connection diagram.
 - ⇒ Do not operate electrical equipment at any time, even for brief measurements or tests, if the ground wire is not permanently connected to the points of the components provided for this purpose.
 - ⇒ Before working with electrical parts with voltage higher than 50 V, the equipment must be disconnected from the mains voltage or power supply. Make sure the equipment cannot be switched on again unintended.
 - ⇒ The following should be observed with electrical drive and filter components:
 - ⇒ Wait five (5) minutes after switching off power to allow capacitors to discharge before beginning to work. Measure the voltage on the capacitors before beginning to work to make sure that the equipment is safe to touch.
 - ⇒ Never touch the electrical connection points of a component while power is turned on.
 - ⇒ Install the covers and guards provided with the equipment properly before switching the equipment on. Prevent contact with live parts at any time.
 - ⇒ A residual-current-operated protective device (RCD) must not be used on electric drives! Indirect contact must be prevented by other means, for example, by an overcurrent protective device.
 - ⇒ Electrical components with exposed live parts and uncovered high voltage terminals must be installed in a protective housing, for example, in a control cabinet.
-

To be observed with electrical drive and filter components:



DANGER

**High electrical voltage on the housing!
High leakage current! Danger to life, danger of
injury by electric shock!**

- ⇒ Connect the electrical equipment, the housings of all electrical units and motors permanently with the safety conductor at the ground points before power is switched on. Look at the connection diagram. This is even necessary for brief tests.
- ⇒ Connect the safety conductor of the electrical equipment always permanently and firmly to the supply mains. Leakage current exceeds 3.5 mA in normal operation.
- ⇒ Use a copper conductor with at least 10 mm² cross section over its entire course for this safety conductor connection!
- ⇒ Prior to startups, even for brief tests, always connect the protective conductor or connect with ground wire. Otherwise, high voltages can occur on the housing that lead to electric shock.

3.6 Protection Against Electric Shock by Protective Low Voltage (PELV)

All connections and terminals with voltages between 0 and 50 Volts on Rexroth products are protective low voltages designed in accordance with international standards on electrical safety.



WARNING

**High electrical voltage due to wrong
connections! Danger to life, bodily harm by
electric shock!**

- ⇒ Only connect equipment, electrical components and cables of the protective low voltage type (PELV = Protective Extra Low Voltage) to all terminals and clamps with voltages of 0 to 50 Volts.
- ⇒ Only electrical circuits may be connected which are safely isolated against high voltage circuits. Safe isolation is achieved, for example, with an isolating transformer, an opto-electronic coupler or when battery-operated.

3.7 Protection Against Dangerous Movements

Dangerous movements can be caused by faulty control of the connected motors. Some common examples are:

- improper or wrong wiring of cable connections
- incorrect operation of the equipment components
- wrong input of parameters before operation
- malfunction of sensors, encoders and monitoring devices
- defective components
- software or firmware errors

Dangerous movements can occur immediately after equipment is switched on or even after an unspecified time of trouble-free operation.

The monitoring in the drive components will normally be sufficient to avoid faulty operation in the connected drives. Regarding personal safety, especially the danger of bodily injury and material damage, this alone cannot be relied upon to ensure complete safety. Until the integrated monitoring functions become effective, it must be assumed in any case that faulty drive movements will occur. The extent of faulty drive movements depends upon the type of control and the state of operation.



DANGER

Dangerous movements! Danger to life, risk of injury, severe bodily harm or material damage!

- ⇒ Ensure personal safety by means of qualified and tested higher-level monitoring devices or measures integrated in the installation. Unintended machine motion is possible if monitoring devices are disabled, bypassed or not activated.
- ⇒ Pay attention to unintended machine motion or other malfunction in any mode of operation.
- ⇒ Keep free and clear of the machine's range of motion and moving parts. Possible measures to prevent people from accidentally entering the machine's range of motion:
 - use safety fences
 - use safety guards
 - use protective coverings
 - install light curtains or light barriers
- ⇒ Fences and coverings must be strong enough to resist maximum possible momentum, especially if there is a possibility of loose parts flying off.
- ⇒ Mount the emergency stop switch in the immediate reach of the operator. Verify that the emergency stop works before startup. Don't operate the machine if the emergency stop is not working.
- ⇒ Isolate the drive power connection by means of an emergency stop circuit or use a starting lockout to prevent unintentional start.
- ⇒ Make sure that the drives are brought to a safe standstill before accessing or entering the danger zone. Safe standstill can be achieved by switching off the power supply contactor or by safe mechanical locking of moving parts.

- ⇒ Secure vertical axes against falling or dropping after switching off the motor power by, for example:
 - mechanically securing the vertical axes
 - adding an external braking/ arrester/ clamping mechanism
 - ensuring sufficient equilibration of the vertical axes
 The standard equipment motor brake or an external brake controlled directly by the drive controller are not sufficient to guarantee personal safety!
- ⇒ Disconnect electrical power to the equipment using a master switch and secure the switch against reconnection for:
 - maintenance and repair work
 - cleaning of equipment
 - long periods of discontinued equipment use
- ⇒ Prevent the operation of high-frequency, remote control and radio equipment near electronics circuits and supply leads. If the use of such equipment cannot be avoided, verify the system and the installation for possible malfunctions in all possible positions of normal use before initial startup. If necessary, perform a special electromagnetic compatibility (EMC) test on the installation.

3.8 Protection Against Magnetic and Electromagnetic Fields During Operation and Mounting

Magnetic and electromagnetic fields generated near current-carrying conductors and permanent magnets in motors represent a serious health hazard to persons with heart pacemakers, metal implants and hearing aids.



WARNING

Health hazard for persons with heart pacemakers, metal implants and hearing aids in proximity to electrical equipment!

- ⇒ Persons with heart pacemakers, hearing aids and metal implants are not permitted to enter the following areas:
 - Areas in which electrical equipment and parts are mounted, being operated or started up.
 - Areas in which parts of motors with permanent magnets are being stored, operated, repaired or mounted.
- ⇒ If it is necessary for a person with a heart pacemaker to enter such an area, then a doctor must be consulted prior to doing so. Heart pacemakers that are already implanted or will be implanted in the future, have a considerable variation in their electrical noise immunity. Therefore there are no rules with general validity.
- ⇒ Persons with hearing aids, metal implants or metal pieces must consult a doctor before they enter the areas described above. Otherwise, health hazards will occur.

3.9 Protection Against Contact with Hot Parts



CAUTION

**Housing surfaces could be extremely hot!
Danger of injury! Danger of burns!**

- ⇒ Do not touch housing surfaces near sources of heat!
Danger of burns!
- ⇒ After switching the equipment off, wait at least ten (10) minutes to allow it to cool down before touching it.
- ⇒ Do not touch hot parts of the equipment, such as housings with integrated heat sinks and resistors.
Danger of burns!

3.10 Protection During Handling and Mounting

Under certain conditions, incorrect handling and mounting of parts and components may cause injuries.



CAUTION

Risk of injury by incorrect handling! Bodily harm caused by crushing, shearing, cutting and mechanical shock!

- ⇒ Observe general installation and safety instructions with regard to handling and mounting.
- ⇒ Use appropriate mounting and transport equipment.
- ⇒ Take precautions to avoid pinching and crushing.
- ⇒ Use only appropriate tools. If specified by the product documentation, special tools must be used.
- ⇒ Use lifting devices and tools correctly and safely.
- ⇒ For safe protection wear appropriate protective clothing, e.g. safety glasses, safety shoes and safety gloves.
- ⇒ Never stand under suspended loads.
- ⇒ Clean up liquids from the floor immediately to prevent slipping.

3.11 Battery Safety

Batteries contain reactive chemicals in a solid housing. Inappropriate handling may result in injuries or material damage.



CAUTION

Risk of injury by incorrect handling!

- ⇒ Do not attempt to reactivate discharged batteries by heating or other methods (danger of explosion and cauterization).
- ⇒ Never charge non-chargeable batteries (danger of leakage and explosion).
- ⇒ Never throw batteries into a fire.
- ⇒ Do not dismantle batteries.
- ⇒ Do not damage electrical components installed in the equipment.

Note: Be aware of environmental protection and disposal! The batteries contained in the product should be considered as hazardous material for land, air and sea transport in the sense of the legal requirements (danger of explosion). Dispose batteries separately from other waste. Observe the legal requirements in the country of installation.

3.12 Protection Against Pressurized Systems

Certain motors and drive controllers, corresponding to the information in the respective Project Planning Manual, must be provided with pressurized media, such as compressed air, hydraulic oil, cooling fluid and cooling lubricant supplied by external systems. Incorrect handling of the supply and connections of pressurized systems can lead to injuries or accidents. In these cases, improper handling of external supply systems, supply lines or connections can cause injuries or material damage.



CAUTION

Danger of injury by incorrect handling of pressurized systems !

- ⇒ Do not attempt to disassemble, to open or to cut a pressurized system (danger of explosion).
- ⇒ Observe the operation instructions of the respective manufacturer.
- ⇒ Before disassembling pressurized systems, release pressure and drain off the fluid or gas.
- ⇒ Use suitable protective clothing (for example safety glasses, safety shoes and safety gloves)
- ⇒ Remove any fluid that has leaked out onto the floor immediately.

Note: Environmental protection and disposal! The media used in the operation of the pressurized system equipment may not be environmentally compatible. Media that are damaging the environment must be disposed separately from normal waste. Observe the legal requirements in the country of installation.

Notes

4 Technical Data

4.1 Equipment

Processor¹⁾	CML40.1: National Geode SC1200, at least with 266 MHz CML40.2: AMD Geode LX800 with at least 500 MHz
Working memory	CML40.1: At least 32 Mbytes DRAM and at least. 64 kbytes NvRAM CML40.2: At least 64 Mbytes DRAM and at least 128 kbytes NvRAM
Interfaces: Interface to functional modules Interface to I/O modules Communication interfaces Ready Contact	<ul style="list-style-type: none"> • Bosch Rexroth PC104^{Plus} • Rexroth Inline interface • 1 x Ethernet connection (RJ 45, 10/100 Base-T) • 1 x serial RS 232 interface <u>Optional:</u> <ul style="list-style-type: none"> • 1 x PROFIBUS DP master-slave interface • 1 x SERCOS master interface <u>Optional:</u> <ul style="list-style-type: none"> • 1 single-pin ready contact
Inputs and outputs	<ul style="list-style-type: none"> • 8 electrically isolated digital inputs • 8 electrically isolated digital outputs

Fig. 4-1: Equipment

¹⁾ For information on the processor and working memory of your IndraControl L40 please refer to the particular system-specific manual.

4.2 Power Supply

The IndraControl L40 is supplied with a voltage of 24 V. The following values of the operating voltage comply with DIN EN 61131-2:

Nominal value	24 VDC
Tolerances	-15 % / +20 % (without residual ripple)
Residual ripple	+ / - 5 %
U _{max}	30 V
U _{min}	19.2 V

The IndraControl L40 requires three operating voltages (see chapter "External Supply Voltages" on page 7-2). Current consumption from these voltages is as follows:

Current consumption by U _{LS}	Max. 2.6 A
Current consumption by U _M and U _S	Max. 8 A in total

Fig. 4-2: Current consumption

Note: The power consumption of the IndraControl L40 (without additional modules and without connected I/O) is typically 9 watts.

4.3 Ambient Conditions

	In operation	Storage/Transport
Max. surrounding air temperature	+5 ... +55 °C If the load is higher or if the surrounding air temperature is > 45 °C, the optionally available blower must be used!	-25 °C to +70 °C
Relative humidity	RH-2; 5 % to 95 % according to DIN EN 61131-2, non-condensing.	
Air pressure	Up to 2,700 m above MSL according to DIN 60204	Up to 3,000 m above MSL according to DIN 60204
Mechanical strength	Max. vibration: Frequency range: 10...150 Hz Excursion: 0.075 mm for 10...0.57 Hz Acceleration: 1 g for 57...150 Hz According to EN 60068-2-6	Max. shock: 15 g according to EN 60 068-2-27, no disturbance of the function
Degree of pollution	2	2

Fig. 4-3: Ambient conditions

Note: The surrounding air must be free from acids, alkaline solutions, corrosive agents, salts, metal vapors, and other electrically conductive contaminants in high concentrations.

The ambient air must be free from dust. Housings and installation compartments must at least comply with degree of protection IP 54 according to DIN VDE 0470-1.

**DANGER****Danger of destruction by overheating**

- ⇒ Ensure a surrounding air temperature of less than 45 °C.
- ⇒ If surrounding air temperatures range from 45 °C to 55 °C, the optionally available blower has to be used. An integrated blower control with hysteresis activates the blower if a critical internal temperature is reached; once the temperature falls below uncritical values, the control deactivates the blower again.
- ⇒ If the temperature reaches a value of 75 °C, the control is automatically entering a standby mode so that damage is prevented. The outputs enter the safe status, and the warning "Temp !!!" appears on the display. This mode can only be quit by switching the power supply off/on.
- ⇒ By means of a lib function, the application program can read the internal temperature of the IndraControl L40, in order to trigger further reactions.

Refraining from a blower may be considered if all of the following conditions are fulfilled:

- Surrounding air temperature < 45 °C
- Load applied to the 7.5-V Inline supply (U_L) < 1 A
- Load caused by the onboard outputs < 1 A
- Load caused by the function modules < 10 W (see fig. 7-27)

4.4 Used Standards

The IndraControl L40 complies with the following standards:

Standard	Meaning
DIN EN 60 204-1	Electrical equipment of machines
DIN EN 61 131-2	Programmable controllers Equipment requirements and tests
DIN EN 60 529	Degrees of protection (incl. housings and installation compartments)
UL 508	Industrial Control Equipment

Fig. 4-4: Used standards

Note: The IndraControl L40 as well as the additionally available function modules correspond to the CE requirements!

Note: Systems with IndraControl L40 components, that are used in residential areas (housing, business and commercial areas as well as small-sized enterprises), require a single approval by an authority or a testing agency. In Germany, such single approvals are issued by the "Regulierungsbehörde für Telekommunikation und Post (RegTP)" (German Regulatory Authority for Telecommunications and Posts).

UL/CSA Certification

The IndraControl L40 units are basically certified according to

- **UL508** (Industrial Control Equipment) and
- **C22.2 No. 142-M1987** (CSA)

However, it is possible that there are combinations or extension stages with restricted or missing certification. Thus, verify the registration according to the UL marking on the device.

Note: To guarantee an UL/CSA-compliant operation, you have to fulfill the following conditions:

- Use 60/75 °C copper wire only.
-

4.5 Compatibility Test

All Rexroth controls and drives are developed and tested according to the latest state-of-the-art.

As it is impossible to follow the continuing development of all materials (e.g. lubricants in machine tools) which may interact with our controls and drives, it cannot be completely ruled out that any reactions with the materials used by Bosch Rexroth might occur.

For that reason, test new lubricants, cleaning agents, etc. for compatibility with our housings / our housing materials before using the particular material concerned.

5 Dimensions

5.1 Housing Dimensions

The IndraControl L40 housing is 175.4 mm long, 120 mm high and 75.9 mm deep. Please refer to the following figures for detailed dimensions:

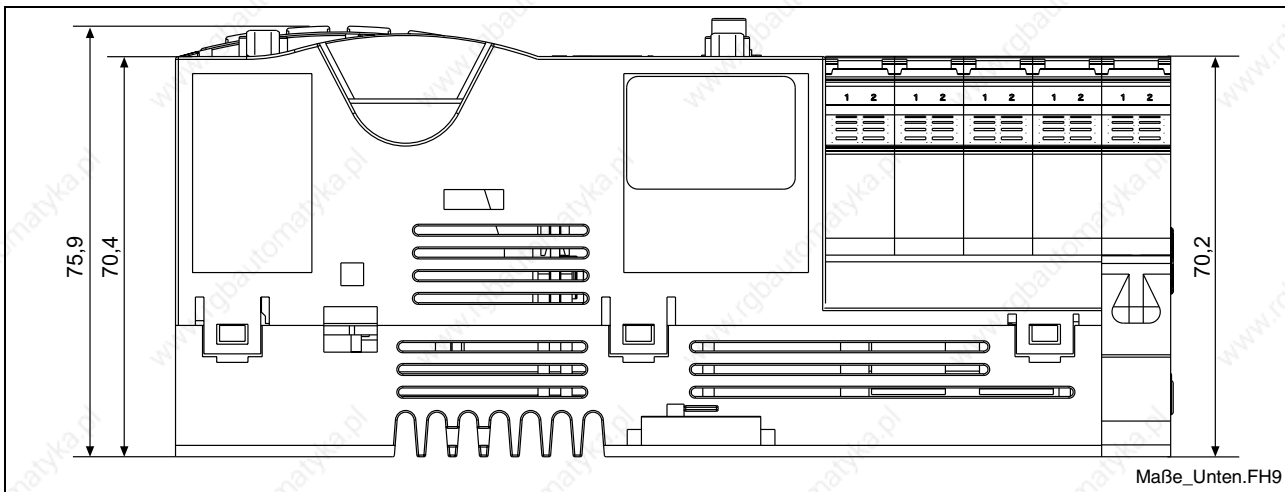

Fig. 5-1: Bottom view

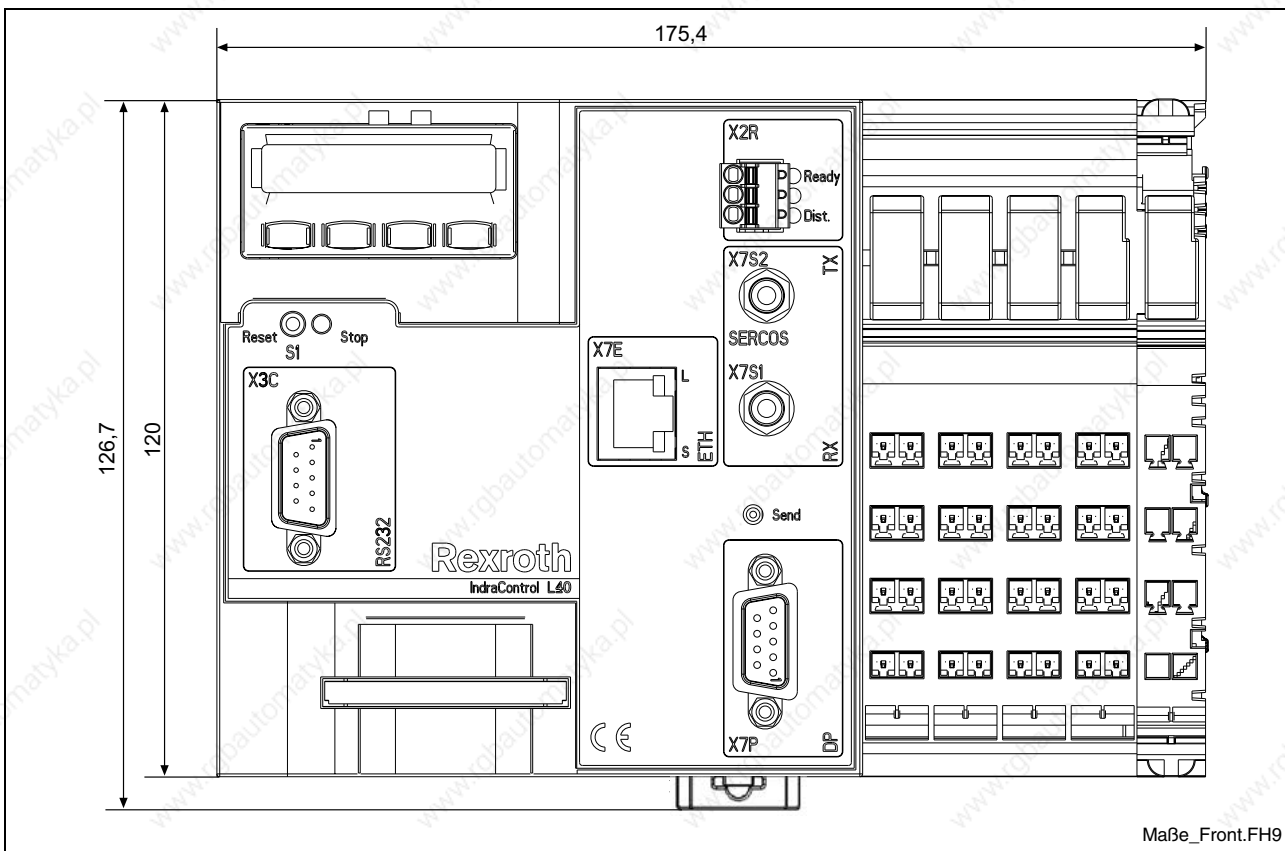

Fig. 5-2: Front view

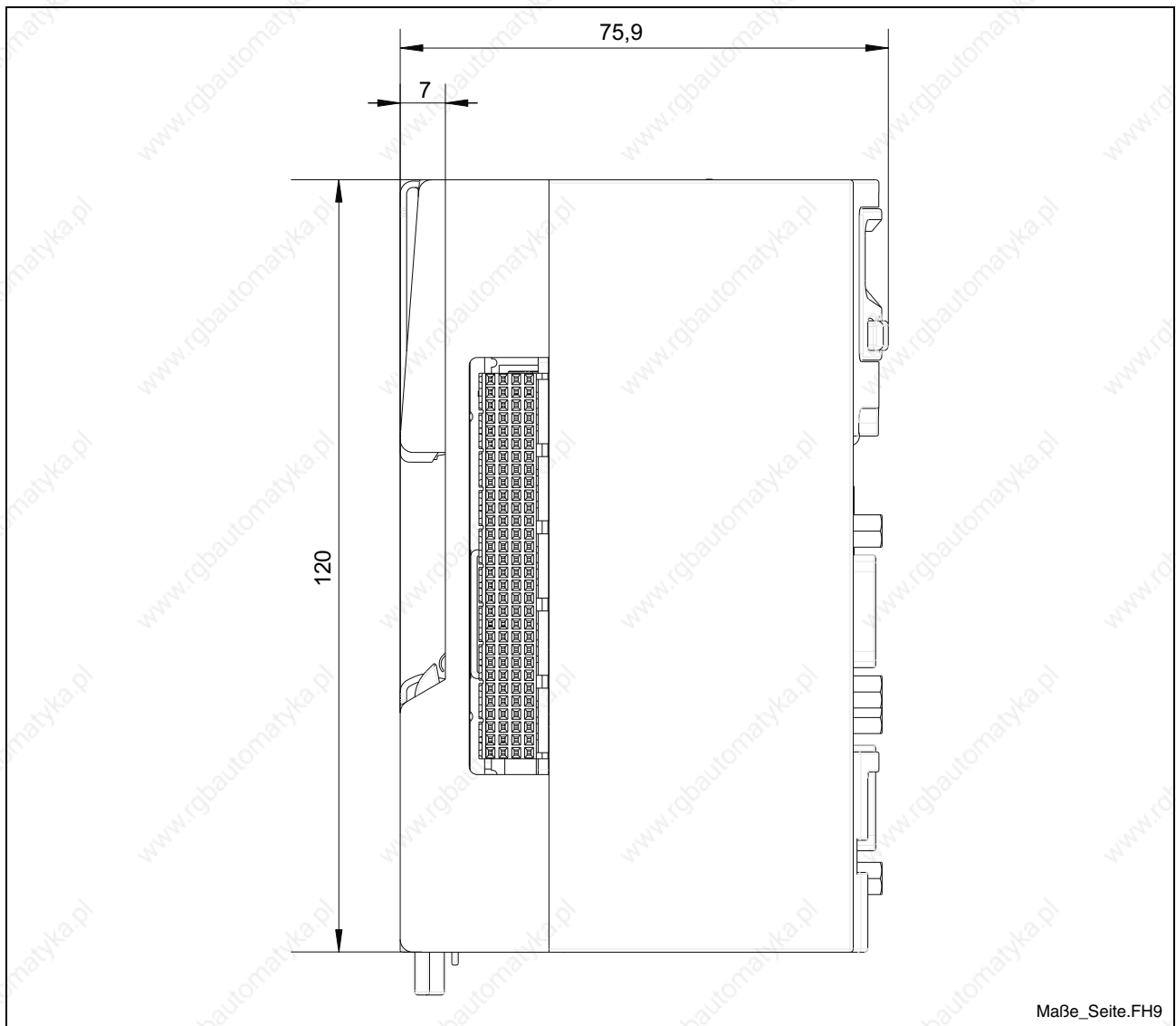

Fig. 5-3: Lateral view from the left
(the cutout for the top-hat rail is arranged centrally)

6 Display and Operating Components

On its front, the IndraControl L40 is provided with the following display and operating components: a single-line display with four operating keys as well as a light-emitting diode and a reset button.

6.1 Display and Operating Keys

Display The display is a LCD display comprising 8 digits (5 x 10 dot matrix).



Anzeige.tif

Fig. 6-1: Display with four operating keys

Operating Keys

- **<Esc>**:
Moves back to the last lower level. Thereby, changes in the exited menu are rejected
- or -
interrupts an input
- **<Down>** (arrow down):
Navigates downwards within a menu
- or -
decrements a selected parameter value
- **<Up>** (arrow up):
Navigates upwards within a menu
- or -
increments a selected parameter value
- **<Enter>**:
Confirms an input/change
- or -
calls the next (lower) menu level

6.2 Reset Button and Light-Emitting Diode

The reset button and a red light-emitting diode are arranged in the section below the display.



Fig. 6-2: Reset button and stop LED

Reset Button

The reset button can only be actuated with a tool, for instance with the tip of a pencil.

Actuating the reset button will reset the complete assembly and force a restart of the unit without the supply voltages having to be turned off. At the same time, the ready contact will be opened (if present).

Note: Actuation of the reset button will abort processing of a running program.

Light-Emitting Diode

The light-emitting diode is a diagnostic / status indicator.

The states indicated by the light-emitting diode depend on the firmware used and are included in the description of the particular system .

7 Connections and Interfaces

7.1 Overview of Connections on the Front

Des. on the housing	Type of connection	Type of connector (integrated)	Mating connector or cable (from outside)
X3C	Serial RS232 interface	D-Sub male connector, 9-pin	D-Sub female connector, 9-pin
X7E	Network connection: Ethernet 10Base T / 100Base X	RJ45 female connector, 8-pin	RJ45 male connector (8-core twisted pair)
X7P	DP: PROFIBUS DP slave	D-Sub female connector, 9-pin	D-Sub male bus connector IP20, 9-pin
X7S2	SERCOS TX	Female optical fiber connector	Male FSMA FO connector
X7S1	SERCOS RX	Female FO connector	Male FSMA FO connector
X2R	Ready contact	3-pin male connector strip, 3.5 mm	3-pin female connector strip, spring force, 3.5 mm (included in scope of delivery)

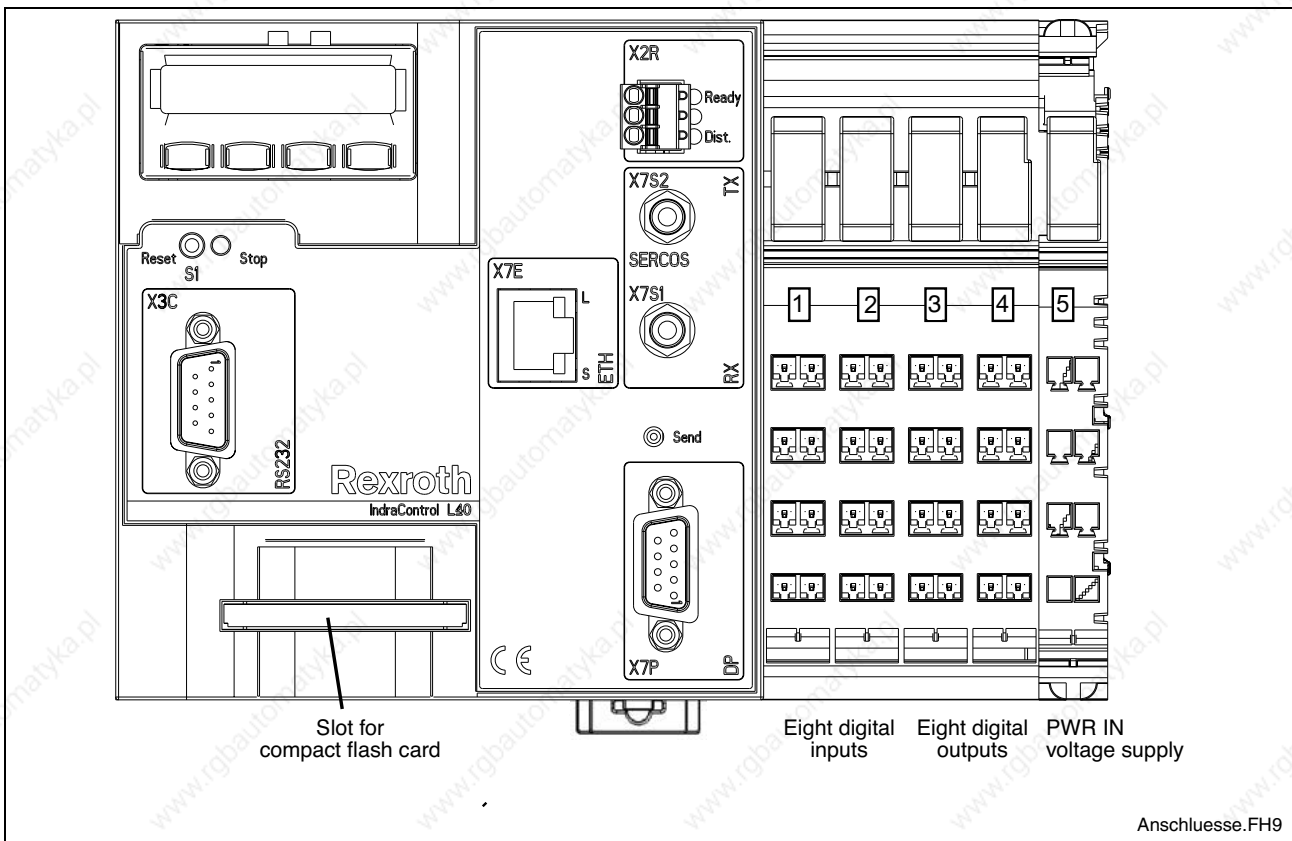

Fig. 7-1: IndraControl L40 connections



CAUTION

Fitting or removing connectors with the IndraControl L40 being live may damage the unit or an additional module!

⇒ Turn off the supply voltage before establishing or breaking any connections!

7.2 Voltage Supply

External Supply Voltages

PWR IN The IndraControl L40 as well as any connected function modules and I/O assemblies are supplied with power via the black terminal strip to the right of the IndraControl L40 unit.

Slot 5:



Fig. 7-2: Supply voltage connections

Note: Observe the color-coding of the connectors.

Note: To connect the operating voltages only the power connector included in the connector set R-IB IL CML S01-PLSET available for the IndraControl L40 is allowed (connector B2 in Fig. 9-4). Connector R-IB IL SCN-PWR IN-CP available for other power terminals is not permitted for the IndraControl L40 (connector B1 in fig. 9-4).

This voltage module (PWR IN) is used to feed the following three voltages: U_{LS} (24 V supply voltage), U_S (24 V segment voltage) and U_M (24 V main voltage):

Terminal	Signal
1.1	+ 24 V DC segment voltage (U_S)
1.2	+ 24 V DC supply voltage (U_{LS})
1.3	LGND (ground supply voltage)
1.4 and 2.4	FE (functional earth ground)
2.1 and 2.2	+ 24 V DC main voltage (U_M)
2.3	PGND (ground main and segment voltages)

Fig. 7-3: Pin assignment of the voltage module

Five light-emitting diodes are arranged at the upper edge. They have the following meaning:

"UM" LED	Meaning
Off	Main circuit supply is missing.
Green	24 V supply U_M of main circuit is present.

Fig. 7-4: Diagnostic LED of the power terminal

"US" LED	Meaning
Off	Segment circuit supply is missing.
Green	24 V supply U_S of segment circuit is present.

Fig. 7-5: Diagnostic LED of the segment terminal

"UL" LED	Meaning
Off	Supply voltage U_{LS} is missing.
Green	24 V supply voltage U_{LS} is present.

Fig. 7-6: Diagnostic LED of the supply voltage

"FS" and "FN" LEDs	Meaning
	No function at present.

Fig. 7-7: "FS" and "FN" LEDs

The 7.5 V Inline voltage U_L and the +24 V analog voltage U_{ANA} are derived from the external +24 V voltage U_{LS} .

24 V Supply Voltage U_{LS}

The internal voltages required in the IndraControl L40 are generated from the 24 V supply voltage U_{LS} (terminal 1.2).

Note: U_{LS} is electrically isolated from the voltages U_M and U_S .
Requirement: A power supply unit that is electrically isolated from the power supply units for U_M and U_S is used for U_{LS} .
 U_M and U_S are not electrically isolated from each other.

+24 V Supply of Main Circuit U_M

The 24 V voltage for supplying the main circuit U_M that is to be fed in at terminals 2.1 and 2.2 is not used in the IndraControl L40.

The main circuit U_M starts at the IndraControl L40 or at a power terminal and is supplied through all following modules up to the next power terminal. At the next power terminal, a new circuit is started; its potential is isolated from the previous one.

Several power terminals can be used within one station.

Function

Several independent segments can be created within the main circuit. The main circuit provides the voltage potential, from which the segment voltages (U_S) are derived. The splitting into segments permits to protect or switch e. g. the supply of several actuators separately.

Current Carrying Capacity

The maximum current carrying capacity is 8 A. If the limit has been reached, a new power terminal **must** be used.

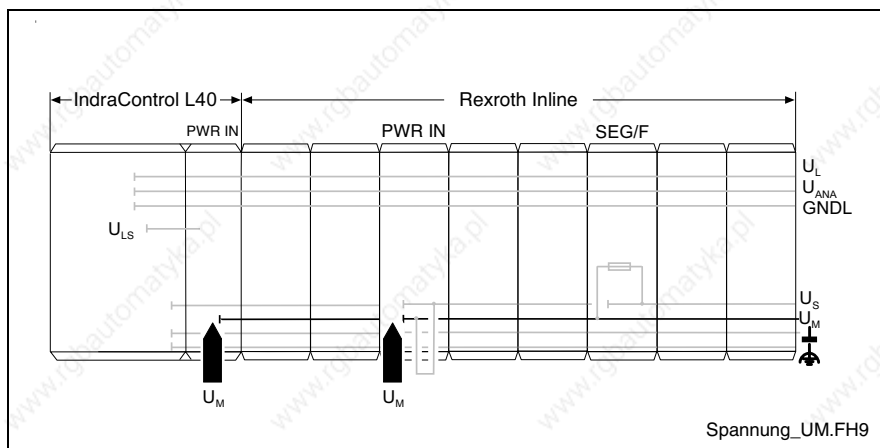

L:	PWR IN	Voltage module at the IndraControl L40
	R-IL 24 PWR IN	Power terminal
	R-IL 24 SEG/F	Segment terminal with fuse

Fig. 7-8: Main circuit

Generation of U_M

In the simplest case, the main voltage U_M can be supplied at the IndraControl L40.

The main voltage U_M can also be supplied via a power terminal. A power terminal **must** be used in the following cases:

- 1 An electrical isolation is to be set up.
- 2 The maximum current carrying capacity of a voltage jumper (U_M , U_S , total current of U_S and U_M (GND)) has been reached.

+24 V Supply of Segment Circuit U_S

The segment circuit supply U_S is to be connected to terminal 1.1 and is supplied through the following series Rexroth Inline I/O modules by the lateral contacts (voltage jumper). It forms the segment circuit or auxiliary circuit of the Rexroth Inline modules and the onboard I/Os.

The segment circuit with the segment voltage U_S starts at the IndraControl L40 or a supply terminal (power terminal or segment terminal) and is supplied through all following modules up to the next supply terminal.

- Function** From U_S the initiator supply as well as the signal voltage of the outputs is provided. You can use several segment terminals within a main circuit and thereby segment the latter. The reference to ground is the same as that of the main circuit. Thus, you can realize within the station differently fused electric circuits without any external cross wiring.
- Voltage** The voltage in the segment circuit is 24 V DC.
- Current Carrying Capacity** The maximum current carrying capacity is 8 A. If the limit for a voltage jumper U_M has been reached (U_M , U_S or total current of U_S and U_M (GND)), a new power terminal must be used.
- Generation of U_S** The segment voltage U_S can be provided in various ways:
 - 1 You can feed in the segment voltage at the IndraControl L40 or at a power terminal.
 - 2 You can tap the segment voltage from the main voltage, either at the IndraControl L40 or at a power terminal using a jumper or a switch.
 - 3 You can use a segment terminal with fuse. In this terminal, the segment voltage is automatically tapped from the main voltage.

Note: At the 120 V and 230 V voltage levels, it is not possible to set up segments. In this case, only the main circuit is used. Special power terminals must be used.

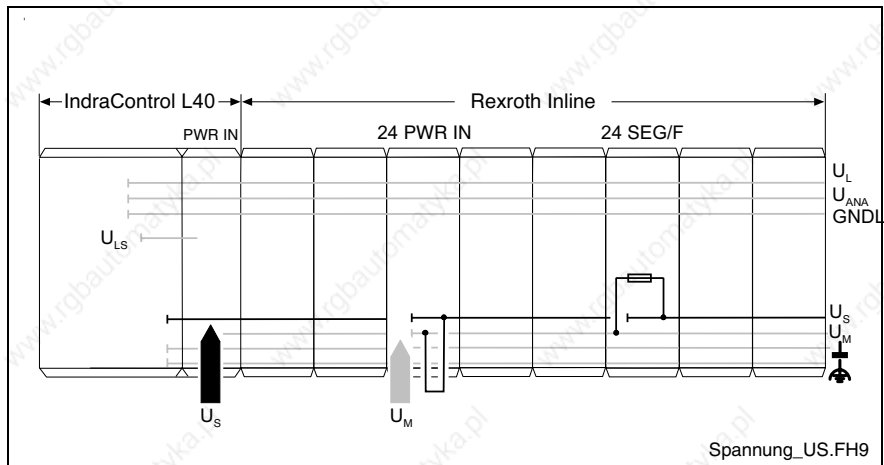

- L: PWR IN Voltage module at the IndraControl L40
- R-IL 24 PWR IN Power terminal
- R-IL 24 SEG/F Segment terminal with fuse

Fig. 7-9: Segment circuit

Note:	Voltages U_M and U_S are electrically isolated from U_L . Requirement: Power supply units that are electrically isolated from the power supply unit for U_{LS} are used for voltages U_M and U_S .
Note:	When designing the station, please note that because of the common GND the total current in the segment circuit U_S and the main circuit U_M must not exceed 8 A.
Note:	U_M is interrupted by the terminal PWR IN. U_S is interrupted by the terminals PWR/IN and SEG/F.

Internally Generated Voltages

+7.5 V Inline Supply U_L

The +7.5 V Inline supply voltage U_L is generated from the supply voltage U_{LS} inside the IndraControl L40 and is supplied through all connected Rexroth Inline I/O modules by the lateral contacts.

Function	Logic voltage is supplied from the Inline voltage to all modules of the station.
Voltage	The voltage in this circuit is 7.5 V.
Generation of the Inline Supply Voltage	The Inline voltage is generated from the supply voltage U_{LS} of the IndraControl L40.
Current Carrying Capacity	The maximum current carrying capacity of the Inline voltage is 2 A. Thus, the total current consumption of all Inline modules must not exceed this value of 2 A.

+24 V Analog Supply (U_{ANA})

The +24 V analog voltage is generated from the voltage U_{LS} . It starts in the IndraControl L40 and is supplied through all Rexroth Inline I/O modules by the lateral contacts (voltage jumper).

Function	The output signals of the analog modules are generated from the analog circuit in the analog terminals.
Voltage	The voltage in this circuit is 24 V.
Generation	The analog voltage U_{ANA} is generated from the supply voltage U_{LS} of the IndraControl L40.
Current Carrying Capacity	The maximum current carrying capacity of U_{ANA} is 0.5 A.

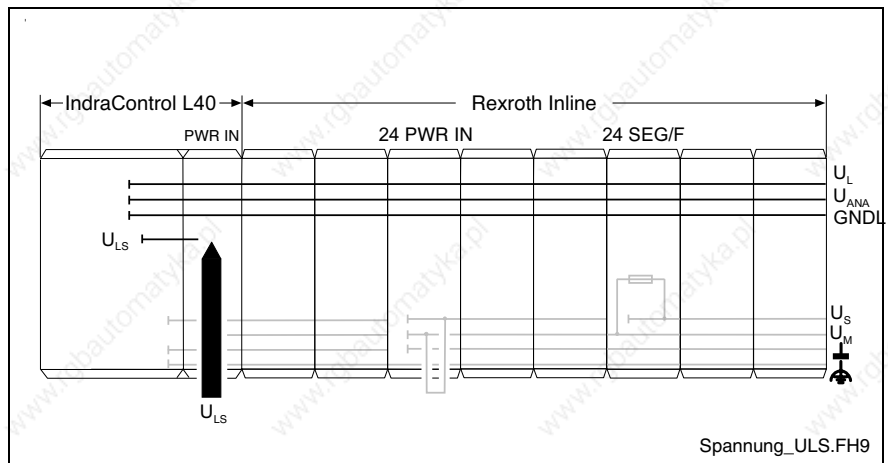

- L: PWR IN Voltage module at the IndraControl L40
- R-IL 24 PWR IN Power terminal
- R-IL 24 SEG/F Segment terminal with fuse

For wiring instructions, please refer to the chapter on "Electric Installation" on page 8-9 and following pages.

7.3 Digital Inputs and Outputs

Address Assignment of Inputs and Outputs

The eight digital inputs and outputs that are available on the slots 1 to 4 of the IndraControl L40 (from left to right) are assigned to light-emitting diodes and bit addresses according to the following table:

	Slot	Eight digital inputs								Eight digital outputs							
		1				2				3				4			
Status LED		1	2	3	4	1	2	3	4	1	2	3	4	1	2	3	4
Byte-bit view	Bytes	IX0.0 – 0.7 (default)								QX0.0 – 0.7 (default)							
	Bit	0	1	2	3	4	5	6	7	0	1	2	3	4	5	6	7
Module	Terminal point (signal)	1.1	2.1	1.4	2.4	1.1	2.1	1.4	2.4	1.1	2.1	1.4	2.4	1.1	2.1	1.4	2.4
	Terminal point (24 V)	1.2	2.2	1.3	2.3	1.2	2.2	1.3	2.3	-	-	-	-	-	-	-	-
	Terminal point (last ground)	-	-	-	-	-	-	-	-	1.2	2.2	1.3	2.3	1.2	2.2	1.3	2.3

Fig. 7-10: Address assignment of inputs and outputs

Digital Onboard Inputs

The left-hand section of the connector panel provides eight digital inputs as onboard inputs.

Slots 1 and 2:

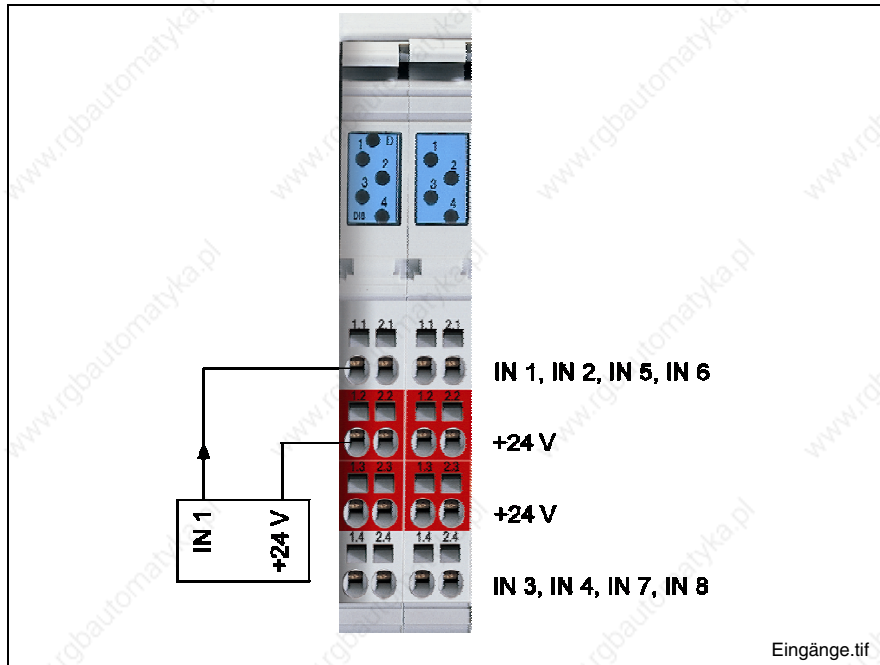

Fig. 7-11: Digital inputs

Note: Observe the color-coding of the connectors.

Number of inputs	8
Connection method	2-wire connection
Electrical isolation from U_S	No
Electrical isolation from U_L	Yes
Reverse voltage protection	Yes
Input voltage: Nominal value at "0" Nominal value at "1"	-3 V ... +5 V 11 V ... 30 V
Input current: Nominal value at "0" Nominal value at "1"	< 2.5 mA 2.8 mA ... 6 mA
Delay time: If "0" to "1" If "1" to "0"	Typ. 50 μ s Typ. 50 μ s
Current consumption by 24 V supply (U_S)	Typ. 60 mA
Cable length (unshielded)	< 100 m
Interrupt inputs	8
Sensor supply	From U_S via a PTC fuse
Output voltage	Typ. $U_{ext} - 1$ V
Nominal current (total)	0.2 A
Short-circuit protection, overcurrent protection	Typ. 0.6 A

Criteria for connecting 2-wire proximity switches: Static current Voltage drop	< 2.5 mA < 6 V
--	-------------------

Fig. 7-12: Data of digital inputs

Light-emitting diodes indicating the current state of the inputs are arranged on the top of the input terminals.

LEDs 1, 2, 3, 4	Meaning
Off	The assigned input is not set.
Yellow	The assigned input is set.

Fig. 7-13: Status LEDs of digital inputs

An additional two-color light-emitting diode (identified by D) emits green light in case the 24 V voltage is present and red light in case of a short-circuit or overload.

Light-emitting diode D	Meaning
Off	24 V voltage is missing.
Green	24 V voltage is present.
Red	Short-circuit or overload.

Fig. 7-14: Light-emitting diode D

Digital Outputs

Two terminal strips with a total of 8 digital outputs are arranged between the digital inputs and the terminals for the voltage supply.

Slots 3 and 4:

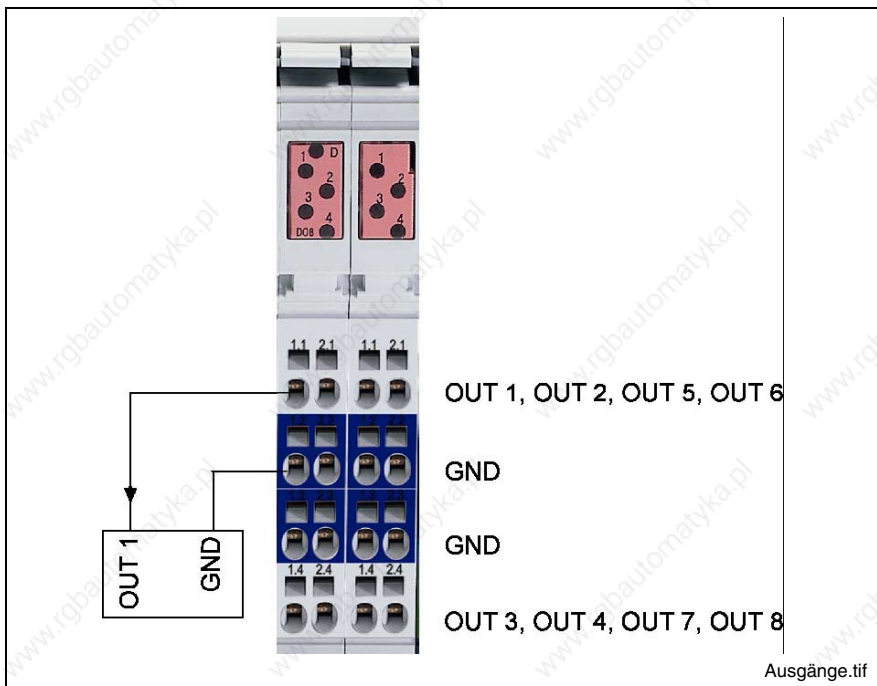

Fig. 7-15: Digital outputs

Note: Observe the color-coding of the connectors.

Number of outputs	8
Connection method	2-wire connection
Output type	<ul style="list-style-type: none"> • Semiconductor outputs, non-saving • Protected, with automatic restart • Current-carrying
Electrical isolation from U_S	No
Electrical isolation from U_L	Yes
Output voltage, nominal value	24 V
Rated output current:	
Nominal value	0.5 A
Maximum value according to DIN EN 61131-2	≤ 0.6 A
1-signal	2 mA ... 0.6 A
0-signal (leakage current)	≤ 0.5 mA
UL-Rating:	
General Purpose	0.5 A
Tungsten	5 W
Maximum total current of outputs	2 A
Parallel connection of outputs	Yes, but only within one terminal
Output delay time	< 500 μ s
Contact size (at 1 Hz)	SG1 (6.2 W)
Lamp load (at 8 Hz)	5 W
Switching frequency	
With ohmic load	100 Hz
With inductive load	Function (contactor)
Overload protection:	
• Typical current level, causing switch-off	1.2 A
• Minimum current level, causing switch-off	0.6 A
• Automatic restart with reduced load	After approx. 10 msec
Overload indicator	Red collective LED for all 8 outputs
Voltage reduced on circuit interruption in the nominal operating mode	Electronically limited to (Vext – 50 V) Typ. 26 V
Reverse voltage protection	Ensured without connected load
Supply voltage according to EN 61131-2	24 V DC
Open-circuit power consumption from U_S	Typ. 50 mA
Cable length (unshielded)	< 100 m

Fig. 7-16: Data of digital outputs

Light-emitting diodes indicating the current status of the outputs are arranged above the output terminals.

LEDs 1, 2, 3, 4	Meaning
Off	The assigned output is not set.
Yellow	The assigned output is set.

Fig. 7-17: Status LEDs of digital outputs

An additional two-color light-emitting diode (identified by D) emits green light in case the 24 V voltage is present and red light in case of a short-circuit or overload.

Light-emitting diode D	Meaning
Off	24 V voltage is missing.
Green	24 V voltage is present.
Red	Short-circuit or overload.

Fig. 7-18: Light-emitting diode D



WARNING

Assembly destruction

If connected improperly, the assembly might be destroyed. For that reason, **avoid**:

- ⇒ Polarity reversal with simultaneous short-circuit of the output lines
- ⇒ Polarity reversal with simultaneous connection of externally polarized suppressor diodes
- ⇒ Applying an external voltage $> U_B$

The 0 V reference voltage of the connected loads must be returned to the 0 V terminal of the IndraControl L40, i. e. a two-pin connection must be ensured. Otherwise, there will be no reliable protection from GND breakage.

7.4 Interfaces

Serial RS232 Interface

X3C Serial RS232 Interface

A serial RS232 interface is provided at X3C.

D-Sub male connector, 9-pin	
Type:	RS232
Cable length:	Max. 15 m
Cable type:	Shielded, twisted

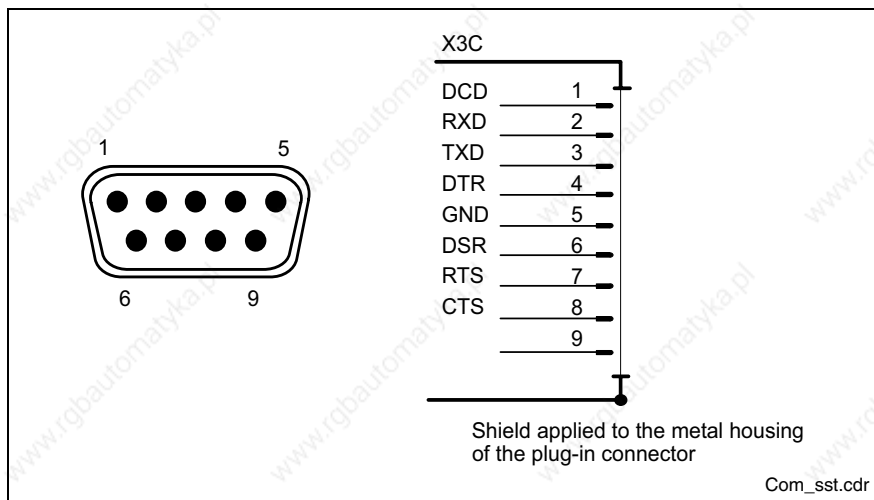

Fig. 7-19: RS232 interface

The interface is electrically isolated. A maximum potential difference of 2 V must be ensured by an appropriate potential equalization between the control and the remote station.

After power on, the following default parameters are set in the IndraControl L40:

- 9600 bauds
- No parity
- 8 data bits
- 1 stop bit

These parameters can be changed via the software or by the application program.

You will find cables for this interface on page 11-6.

Ethernet Interface

X7E Ethernet Network Connection

Connector X7E can be used to connect the IndraControl L40 to an Ethernet network.

The connection requirements defined for 100BaseT in IEEE 802.3 are applicable to Ethernet network connections.

RJ45 female connector, 8-pin	
Type:	Ethernet 100BaseT
Cable length:	Max. 100 m
Cable type:	Shielded, twisted pair
Transmission rate:	10 or 100 Mbits/s

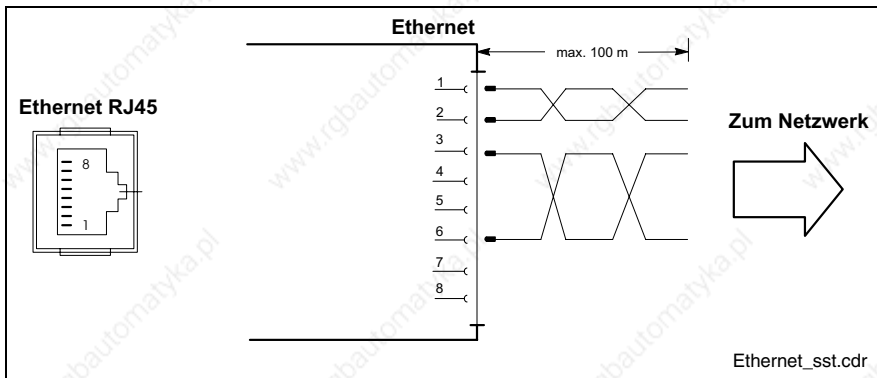

Fig. 7-20: Ethernet interface

Two LEDs are integrated in the RJ45 female connector indicating the connection status:

- LED at the top (Link): Flashes green, if there is an Ethernet connection
- LED at the bottom (Send): Flashes orange, if the data transmission occurs via this line

Bosch Rexroth recommends the use of an STP cable of category 5. You will find cables for this interface on page 11-6.

PROFIBUS DP (Optional)

**X7P
PROFIBUS DP Interface**

Optionally, the IndraControl L40 provides a PROFIBUS interface according to DIN EN 50170, Part 2.

D-Sub female connector, 9-pin	
Type:	RS485
Cable type:	Shielded, twisted pair
Transmission rate:	10 or 100 Mbits/s

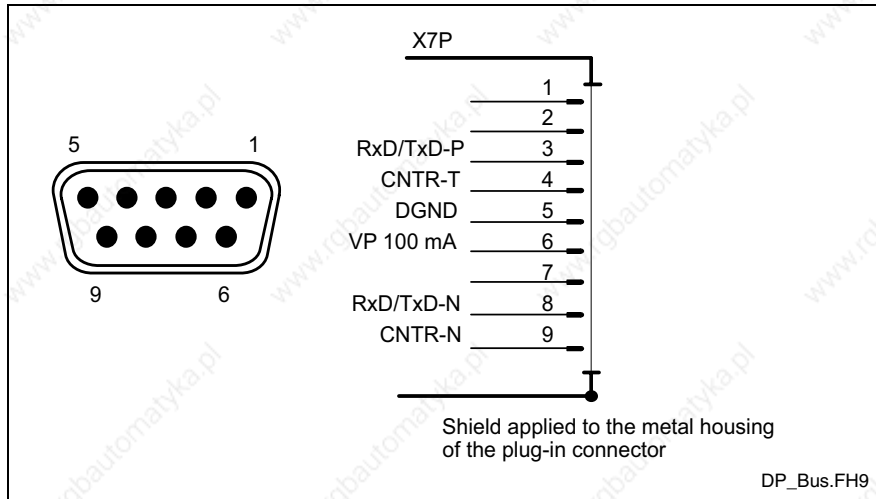

The bus line is specified as cable type A according to EN 50 170, part 8-2 and must comply with the cable parameters named in Fig. 7-21. You will find the corresponding cables and connectors on page 11-6.

Surge impedance at a frequency within a range from 3 to 20 MHz	135 to 156 ohms
Operating capacity	≤ 30 pF/m
Loop resistance	≤ 110 ohms/km
Outside diameter	> 0.64 mm
Core cross-section	> 0.34 mm ²

Fig. 7-21: Parameters for PROFIBUS DP line

The above mentioned cable parameters of a standard cable of cable type A result in the following length extensions of a bus segment for the particular transmission rates:

Transmission rate in kbits/s	9,6	19,2	45,45	93,75	187,5	500	1500	3000	6000	12000
Max. segment length in m	1200	1200	1200	1200	1000	400	200	100	100	100

Fig. 7-22: Maximum segment length in relation to the transmission rate

A "Send" light-emitting diode is arranged on the top of the PROFIBUS interface.

"Send" LED	
LED on	Output of data by the IndraControl L40

Fig. 7-23: "Send" light-emitting diode

SERCOS (Optional)

X7S1 and X7S2 SERCOS Interface

The optical SERCOS fibers must be connected to the optional connectors X7S1 (receiver) and X7S2 (transmitter). Since a SERCOS bus is of circular setup, the optical fiber cables must be properly connected to these two connectors. The SERCOS interface can be operated with 2, 3, 8, or 16 Mbauds. The transmission rate as well as the transmitter output can be set by means of the firmware.

A red "Dist." light-emitting diode is assigned to the SERCOS interface.

"Dist." LED	Meaning
Off	Normal state
Red	The distortion is too high or the receive signal is missing.

Fig. 7-24: Distortion indicator

Ready Contact (Optional)

X2R Ready Contact

Pins 1 and 2 of the 3-pin strip X2R are the connection points for the optional ready contact.

The ready contact has a single-channel setup.

Characteristic relay data (photo-MOS relay)	
Switching capacity	1 A, 60 V DC (resistive)
Dropout time	0.3 ms
Bounce time	None
Watchdog time (analog WD only)	50 ms ± 25 %

Fig. 7-25: Characteristic data of the ready contact

If it is in the release status, the ready contact is open. After powering up the assembly, the contact is closed. The contact is opened again, if one of the states listed below occurs:

- The 24 VDC supply voltage falls below the permissible limit.
- The internal 5 V and 3.3 V voltages fall below the permissible limit.
- The ready watchdog is elapsing.
- The reset button is actuated.

The LED arranged next to the ready contact is a red-green dual LED. It can assume the following states:

"Ready" LED	Meaning
Off	Watchdog not started yet or ready contact opened via the software (but the watchdog is still triggered internally)
Green	Ready contact closed; watchdogs still triggered.
Red	Ready error; at least one watchdog has responded.

Fig. 7-26: Ready LED

Interface for Compact Flash Card

Compact Flash

The IndraControl L40 is provided with a slot for a compact flash card. This slot can be used to insert the memory card containing the firmware (card to be ordered separately). In addition, data and programs are stored to this card. Operation without flash card is not possible.



DANGER

Operation without memory card causes uncontrolled movements!

⇒ Be sure not to remove the compact flash card as long as the IndraControl L40 is in operation.

7.5 Inline Bus

To its right, the IndraControl L40 can be extended by additional Rexroth Inline modules. Such modules permit an extension of the I/O unit to 32-byte inputs and 32-byte outputs.

The maximum number of Rexroth Inline modules that can be connected is 63.

Note: For further information on the connection of Rexroth Inline modules, please refer to Chapter "Structure of the Rexroth Inline Terminals" on page 9-1 and following pages.

7.6 Function Modules

Overview

To its left, the IndraControl L40 is provided with a functional module connector that can be used to connect up to four extension modules. For this, please observe the installation notes of the IndraControl L40 in the corresponding chapter.

This 120-pin connector is a Bosch Rexroth PC104^{Plus} connector where the PCI signals as well as additional system-specific signals are applied. In other words, only the function modules especially developed for the IndraControl L40 can be connected to this connector.

For the appropriate cables to connect the IndraControl with the function modules please refer to section "Interface Cables" as of page 11-6.

Note: The single function modules are not supported by every system! For information on which function modules are supported by the used system, please refer to the particular system-specific manual.

Technical Data

Power Supply The function modules are supplied from the internal voltage of the IndraControl L40.

Current and Power Supply

Function module	Consumption	Current consumption	Power consumption
CFL01.1-Y1 SRAM	from 3.3 V:	300 mA	1.0 W
	Total power consumption:		1.0 W
CFL01.1-V1 DeviceNet Master	from 3.3 V:	400 mA	1.4 W
	from 24 V (DeviceNet voltage):	55 mA	1.4 W
	Total power consumption:		2.8 W
CFL01.1-P1 Profibus master	from 3.3 V:	500 mA	1.65 W
	Total power consumption:		1.65 W
CFL01.1-R3 Sercos III	from 3.3 V:	270 mA	0.9 W
	from 5 V:	230 mA	1.15 W
	Total power consumption:		2.05 W
CFL01.1-Q2 Cross Communication	from 3.3 V:	150 mA	0.5 W
	from 5 V:	360 mA	1.8 W
	Total power consumption:		2.3 W
CFL01.1-E2 Fast I/O	from 3.3 V:	90 mA	0.3 W
	Total power consumption:		0.3 W
CFL01.1-N1 cam switch	from 3.3 V:	400 mA	1.4 W
	from 5 V:	55 mA	1.4 W
	Total power consumption:		2.8 W

Fig. 7-27: Current and power supply

Ambient Conditions

Ambient conditions	In operation	Storage/ Transport
Max. surrounding air temperature	+5 ... +55 °C	-25 °C to +70 °C
Relative humidity	RH-2; 5 % to 95 % according to DIN EN 61131-2, non-condensing.	
Air pressure	Up to 2,700 m above MSL according to DIN 60204	Up to 3,000 m above MSL according to DIN 60204
Mechanical strength	Max. vibration: Frequency range: 10...150 Hz Excursion: 0.075 mm for 10...0.57 Hz Acceleration: 1 g for 57...150 Hz According to EN 60068-2-6	Max. shock: 15 g according to EN 60 068-2-27, no disturbance of the function

Fig. 7-28: Ambient conditions

**DANGER****Danger of destruction by overheating!**

⇒ Ensure a surrounding air temperature of less than 55 °C.

Note: The surrounding air must be free from acids, alkaline solutions, corrosive agents, salts, metal vapors, and other electrically conductive contaminants in high concentrations.

The ambient air must be free from dust. Housings and installation compartments must at least comply with degree of protection IP 54 according to DIN VDE 0470-1.

CFL01.1-Y1 SRAM Function Module

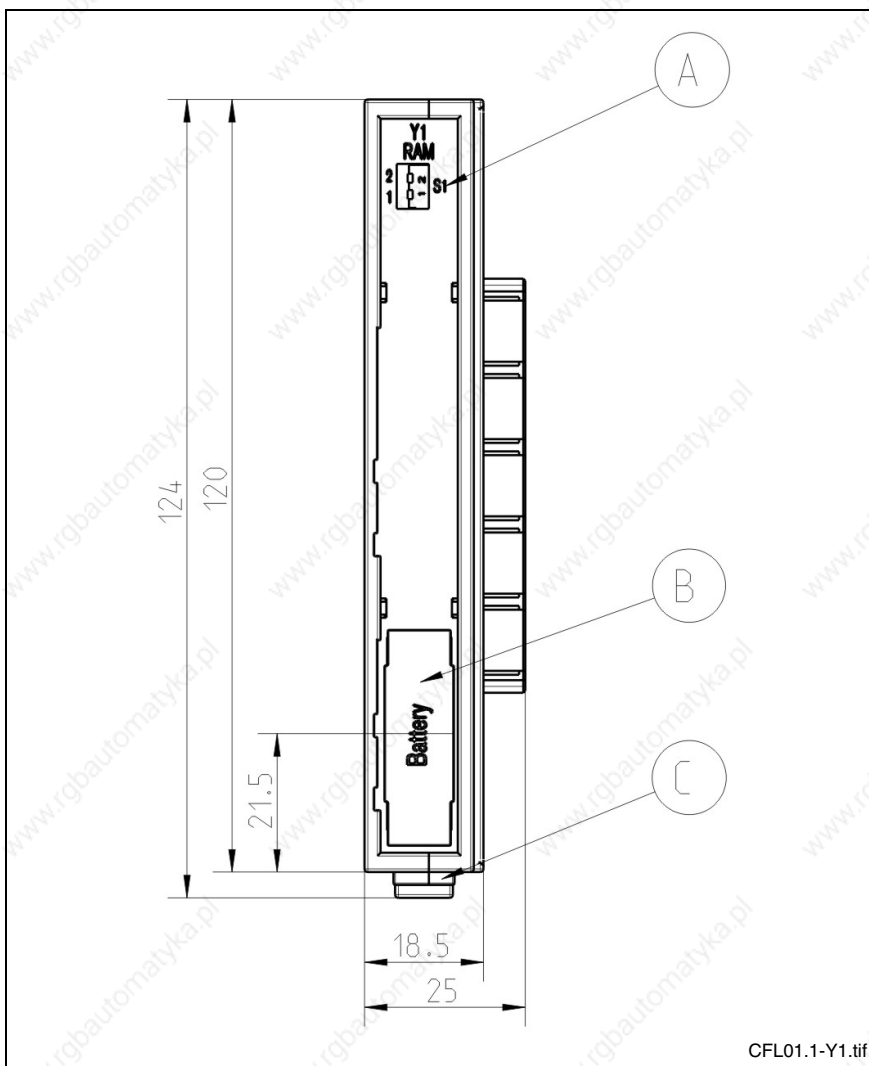

- A S1, switch for slot number
- B Battery case
- C Mounting rail interlock

Fig. 7-29: SRAM function module

The battery inserted in the module is automatically activated with the first commissioning and buffers then the data of the storage module for several years.

The control software monitors the battery and sends a warning if the battery capacity decreases.

In this case, you should exchange the battery immediately:

Battery Exchange Open the battery case when the control is switched on and pull the battery with the plastic strap out of the housing.

Note: Data loss when control is switched off!
Consider that the control is switched on during battery exchange.

Insert the new battery (see Fig. 7-30) and lock the battery cover in place.
Use the following battery type: CR2450
Please order spare batteries under CAP01.1-B2.

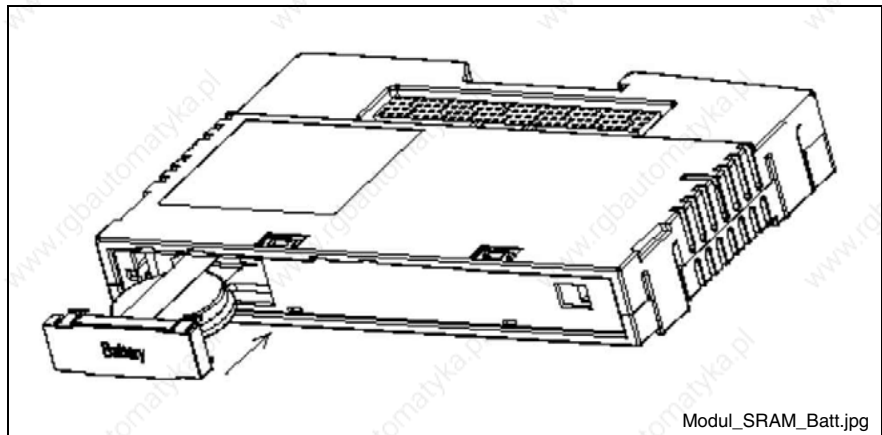

Fig. 7-30: Insert new battery



WARNING

Batteries might cause fire, explosions or chemical burn!

- ⇒ Do not load, remove, destroy, burn or heat batteries over 100°C.
- ⇒ Dispose old batteries immediately and properly. Keep away from children!

CFL01.1-V1 DeviceNet Master Function Module

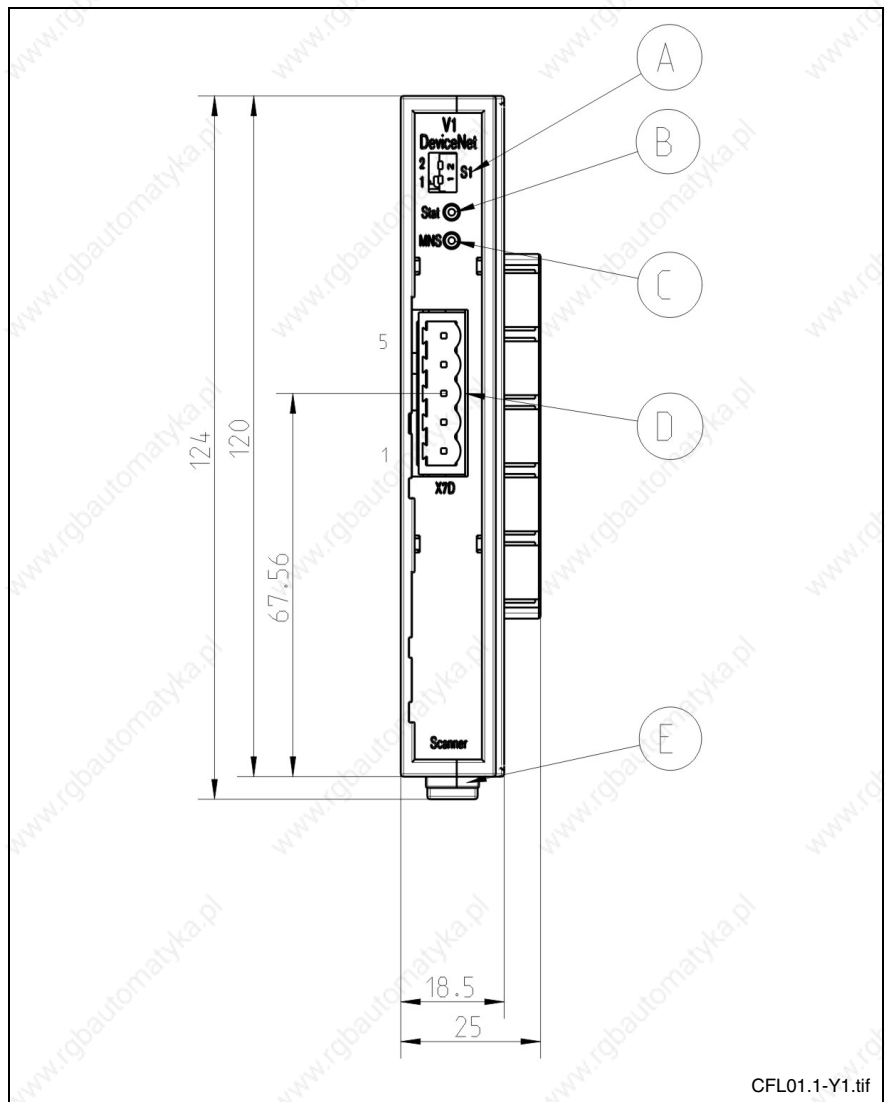

CFL01.1-Y1.tif

- A S1, switch for slot number
- B Stat, status indicator of the function module
- C MNS, module/network status
- D X7D, DeviceNet connector
- E Mounting rail interlock

Fig. 7-31: DeviceNet master module

**X7D
DeviceNet Interface**

Pin	Meaning
1	V -
2	CAN_L
3	Shield
4	CAN_H
5	V +

Fig. 7-32: Pin assignment of the X7D connector

Note: Cable fixing during installation required!

For further descriptions please refer to the particular system-specific manual.

Indicator Elements

The meaning of the indicator elements (two LEDs) are listed in the following table:

LED	Color	Status	Flash frequency	Description
Stat.	Red	Flashing	Slowly, 1 Hz	Device is in boot load mode and is waiting for a firmware download
		Flashing	Fast, 5 Hz	Firmware is loaded
		Acyclically flashing	3 times fast with 5 Hz 8 times slow 0,5 Hz to 1 Hz	Hardware error detected, the device has to be exchanged, please contact Bosch Rexroth.
	Green	Cyclically flashing	Fast, 5 Hz	No configuration error, device is online and ready for the field bus communication; attempt to establish a connection, but field bus device not yet found.
		Acyclically flashing	3 times fast with 5 Hz 8 times slow 0,5 Hz to 1 Hz	<u>During switching on:</u> Configuration is missing, device has to be configured <u>In operation:</u> critical firmware, like e. g. timeout
		Statically at	-	Device has established at least one configured connection.
	Off	-	-	Device has no power supply.
MNS	Green	Statically at	-	Device is online, connections established. Device is connected with another master. Device has established a connection to a slave.
		Flashing	Slowly, 1 Hz	Device is online, no connection established. Configuration is missing. Device has terminated the address verification, but no connection to another device established.
	Red	-	-	Device has no access on the bus, because of bus error. Double addressing determined.
	Off	-	-	Device is not online, the address verification is not terminated. Device has no supply voltage.

Fig. 7-33: Meaning of the light emitting diodes at the DeviceNet master function module

CFL01.1-P1 Profibus DP Master Function Module

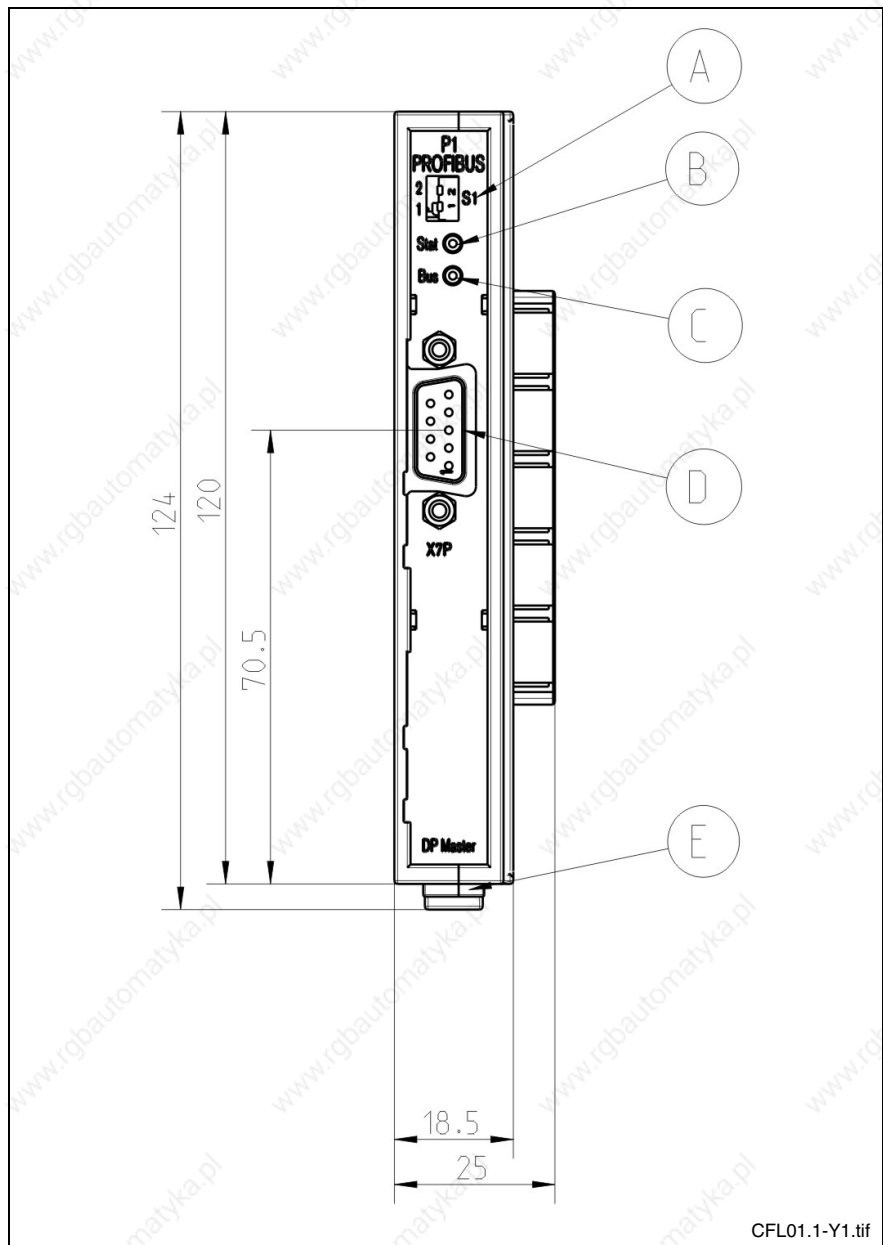

CFL01.1-Y1.tif

- A S1, switch for slot number
- B Stat, status indicator of the function module
- C Bus, DP status
- D X7P, Profibus DP connector
- E Mounting rail interlock

Fig. 7-34: Profibus DP master function module

Note: Cable fixing during installation required!

For further descriptions please refer to the particular system-specific manual.

**X7D
PROFIBUS Interface
DSub Female Connector, 9-Pin**

Pin	Meaning
1	N. C.
2	N. C.
3	RxD / TxD – P
4	CNTR – P
5	DGND
6	VP
7	N. C.
8	RxD / TxD – N
9	N. C.

Fig. 7-35: Pin assignment of the X7D connector

Indicator Elements The meaning of the indicator elements (two LEDs) are listed in the following table:

LED	Color	Status	Flash frequency	Description
Stat.	Red	Flashing	Slowly, 1 Hz – { } –	Device is in boot load mode and is waiting for a firmware download.
		Flashing	Fast, 5 Hz	Firmware is loaded.
		Acyclically flashing	3 times fast with 5 Hz 8 times slow 0,5 Hz to 1 Hz	Hardware error detected, the device has to be exchanged, please contact Bosch Rexroth.
	Green	Cyclically flashing	Fast, 5 Hz	No configuration error, device is online and ready for the field bus communication; attempt to establish a connection, but field bus device not yet found.
		Acyclically flashing	3 times fast with 5 Hz 8 times slow 0,5 Hz to 1 Hz	<u>During switching on:</u> Configuration is missing, device has to be configured <u>In operation:</u> critical firmware, like e. g. timeout
		Statically at	-	Device has established at least one configured connection.
	Off	-	-	Device has no power supply.
Bus	Green	Statically at	-	Device is online, connections established. Device is connected with another master. Device has established a connection to a slave.
		Flashing	Slowly, 1 Hz	Device is online, no connection established. Configuration is missing. Device has terminated the address verification, but no connection to another device established.
	Red			Device has no access on the bus, because of bus error. Double addressing determined.
	Off	-	-	Device is not online, the address verification is not terminated. Device has no supply voltage.

Fig. 7-36: Meaning of the light-emitting diodes at the DP master function module

CFL01.1-R3 SERCOS III Function Module

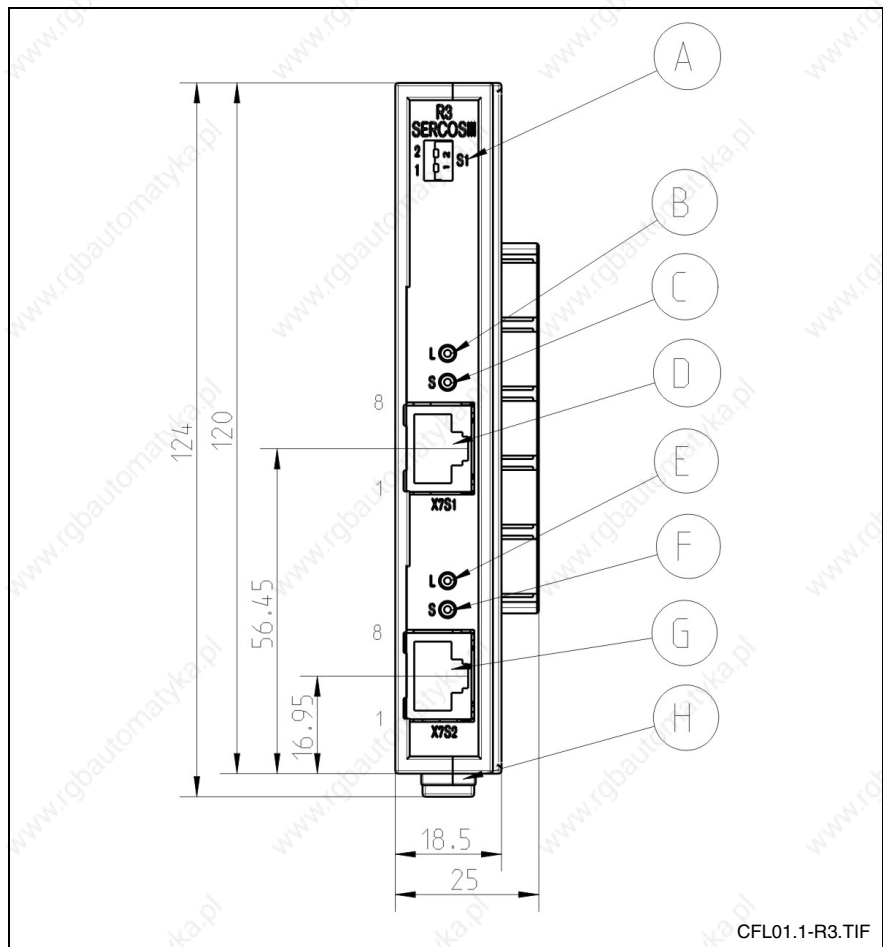

- A S1, switch for slot number
- B Indicator (PORT1) LINK, green
- C Indicator (PORT1) ACTIVITY, yellow
- D X7S1, PORT1 – SERCOS III interface (RJ45)
- E Indicator (PORT2) LINK, green
- F Indicator (PORT2) ACTIVITY, yellow
- G X7S2, PORT2 – SERCOS III interface (RJ45)
- H Mounting rail interlock

Fig. 7-37: SERCOS III module

X7S1, X7S2 SERCOS III Interface

Pin	Meaning
1	TX+ Transmitted data plus
2	TX- Transmitted data minus
3	RX- Received data plus
6	RX- Received data minus
Housing	Shield

Fig. 7-38: Pin assignment of the X7S1, X7S2 connector

Bosch Rexroth recommends the use of an STP cable of category 5. You will find cables for this interface on page 11-7.

Note: Cable fixing during installation required!

For further descriptions please refer to the particular system-specific manual.

CFL01.1-Q2 Cross Communication Function Module

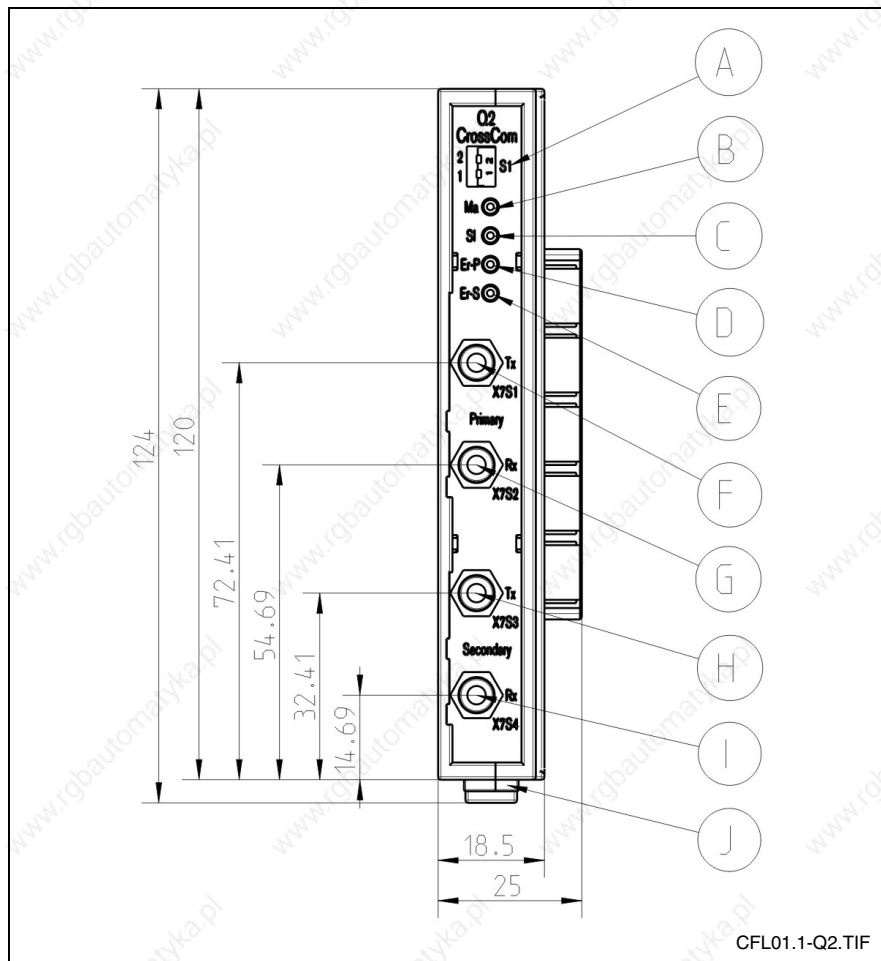

- A S1, switch for slot number
- B Ma, indicator of the cross communication MASTER mode
- C Sl, indicator of the cross communication SLAVE mode
- D Er-P, primary ring error
- E Er-S, secondary ring error
- F X7S1, FO transmitter of the primary ring (SERCOS transmitter)
- G X7S2, FO receiver of the primary ring (SERCOS receiver)
- H X7S3, FO transmitter of the secondary ring (SERCOS transmitter)
- I X7S4, FO receiver of the secondary ring (SERCOS receiver)
- J Mounting rail interlock

Fig. 7-39: Cross communication function module

Note: Cable fixing during installation required!

For further descriptions please refer to the particular system-specific manual.

CFL01.1-E2 Fast I/O Function Module

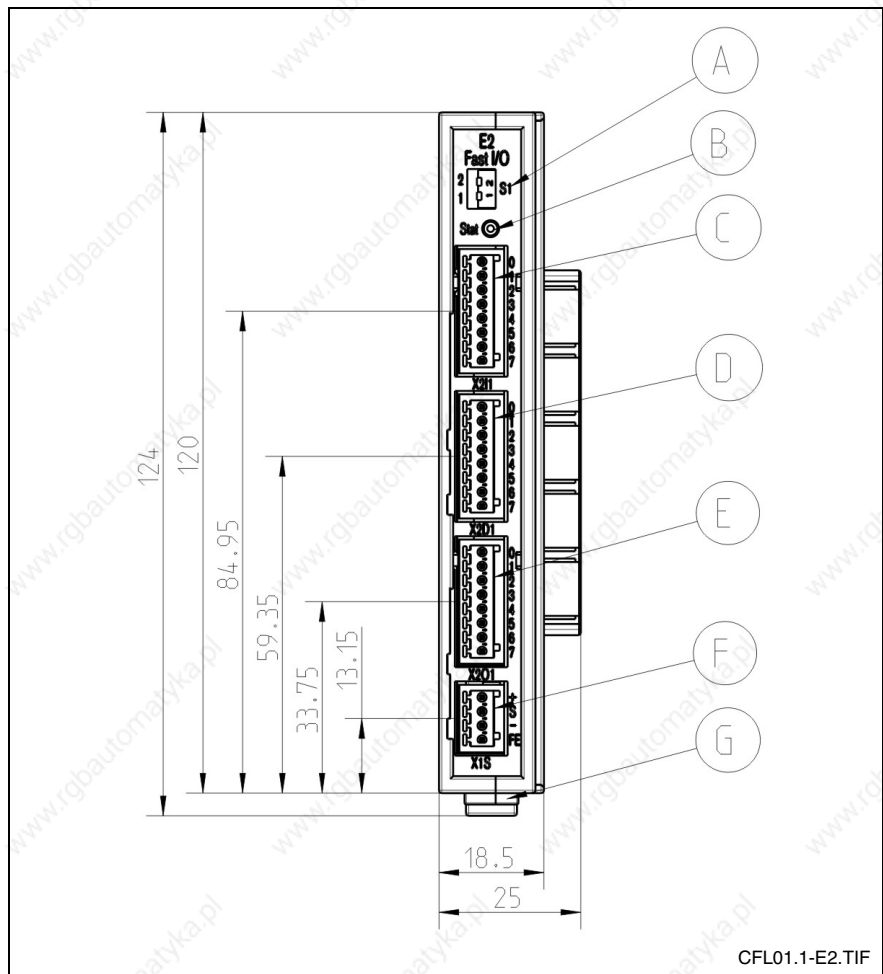

- A: S1, switch for slot number
- B: Stat, status indicator of the function module
- C: X2I1, digital inputs
- D: X2D1, digital inputs/outputs
- E: X2O1, digital outputs
- F: X1S, power supply and FE
- G: Mounting rail interlock

Fig. 7-40: Fast I/O function module

Properties

Each Fast I/O function module is equipped as follows:

- 8 inputs
- 8 inputs/outputs (selectable bit by bit)
- 8 outputs
- 3 MICRO COMBICON spring terminals with 8 outputs and 8 inputs (X2I1, X2D1 and X2O1)
- 1 MICRO COMBICON spring terminal with power supply and functional earth ground
- LED status indicator power fail and overload
- Current per output 500 mA for 24 V nominal voltage
- Delay time of the inputs 0 -> 1 typ. 40 μs, 1 -> 0 typ. 45 μs
- Delay time of the outputs 0 -> 1 typ. 70 μs, 1 -> 0 typ. 70 μs

Interfaces

Input connector X2I1 connection	Input/output connector X2D1 connection	Output connector X2O1 connection
Input 0	Input/output 0	Output 0
Input 1	Input/output 1	Output 1
Input 2	Input/output 2	Output 2
Input 3	Input/output 3	Output 3
Input 4	Input/output 4	Output 4
Input 5	Input/output 5	Output 5
Input 6	Input/output 6	Output 6
Input 7	Input/output 7	Output 7

Fig. 7-41: Input and output connectors X2I1, X2D2 and X2O1

Feeder connector X1S connection
24 V (+)
S (sensor supply)
GND (-)
FE

Fig. 7-42: Feeder connector X1S

Note: The function module has to be grounded with two 0.5 mm² conductors at the FE plug and socket connections. These conductors must have a length of maximum 0.5 m.

The FE functional earth ground is intended to discharge disturbances. It is not provided as a protection against electric shock for persons.

Indicators

The status LED shows three states:

Light-emitting diode Stat	Meaning
Green	Supply voltage available. Module ready for operation.
Red	Supply voltage is missing. Short-circuit or overload at one or several outputs. PCI interface defective (module defective). Watchdog error (module is not addressed by the system).
Off	Supply voltage of the control is missing.

Fig. 7-43: States of the status LED

Wiring the Module

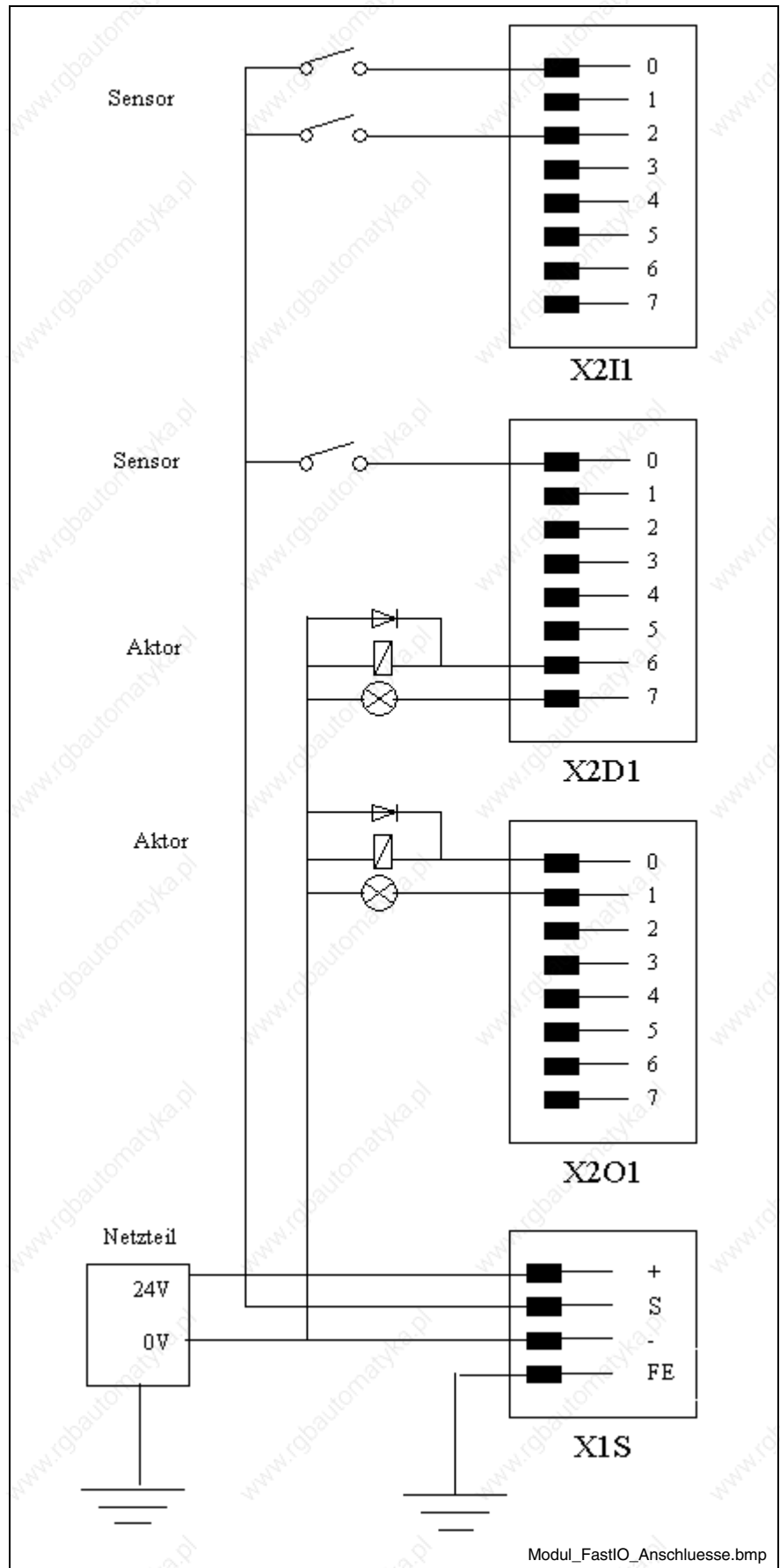

Fig. 7-44: Wiring the module

**WARNING****Destruction of the module by improper connection!**

- ⇒ Avoid polarity reversal with simultaneous short-circuit of the output lines
- ⇒ Avoid polarity reversal with simultaneous connection of externally polarized suppressor diodes
- ⇒ Do not apply an external voltage greater than the supply voltage
- ⇒ Do not connect sensors to an external voltage. Sensors have to be supplied from the sensor supply (X1S).

**WARNING****Damages of the module!**

- ⇒ If the maximum permissible current consumption of the function module is exceeded, components of the module can be destroyed
- ⇒ Removing and inserting the spring terminals under electrical voltage can damage the electrical contacts

Digital Inputs X2I1, X2D1

Number of inputs	16 (8 of the 16 can be selected bit by bit as input or output)
Connection method	1-wire connection
Input type	Type 1, according to EN 61131-2
Electrical isolation to the logic supply	Yes
Reverse voltage protection	Yes
Input voltage:	
Nominal value at "0"	-3 V ... +5 V
Nominal value at "1"	11 V ... 30 V
Input current:	
Nominal value at "0"	< 2.5 mA
Nominal value at "1"	2.8 mA ... 6 mA
Delay time:	
If "0" to "1"	Typ. 40 µs, max. 50 µs
If "0" to "1"	Typ. 45 µs, max. 55 µs
Cable length (unshielded)	< 100 m
Sensor supply (connection "S")	
Output voltage, nominal value	24 V
Nominal current (total)	0.2 A
Short-circuit protection, overcurrent protection	Typ. 1.2 A

Fig. 7-45: Data of digital inputs

Digital Outputs X2I1, X2D1

Number of outputs	16 (8 of the 16 can be selected bit by bit as input or output)
Connection method	1-wire connection
Output type	Semiconductor outputs, non-saving Protected, with automatic restart Current-carrying
Electrical isolation to the logic supply	Yes
Output voltage, nominal value	24 V
Rated output current:	
Nominal value	0.5 A
Maximum value according to DIN EN 61131-2	≤ 0.6 A
1-signal	2 mA ... 0.6 A
0-signal (leakage current)	≤ 0.5 mA
UL rating:	
General Purpose	0.5 A
Tungsten	5 W
Parallel connection of outputs	Yes, but only within one half byte (0-3;4-7 etc.)
Maximum total current of outputs	4 A
Output delay time (ohmic load)	
If "0" to "1"	Typ. 70µs, max. 95 µs
If "1" to "0"	Typ. 70µs, max. 75µs
Contactor size (at 1 Hz) (inductive load)	SG1 (6.2 W)
Lamp load (at 8 Hz)	5 W
Overload protection:	
Typical current level, causing switch-off	1.2 A
Minimum current level, causing switch-off	0.6 A
Automatic restart with reduced load	After approx. 10 ms
Overload indicator	Red collective LED for all 16 outputs
Voltage reduced on circuit interruption in the nominal operating mode, limited to	Electronically limited to (Vext – 50 V) Typ. 26 V
Reverse voltage protection	Ensured without connected load
Supply voltage according to EN 61131-2	24 V DC
Open-circuit power consumption from 24 V	Typ. 20 mA
Cable length (unshielded)	< 100 m

Fig. 7-46: Data of digital outputs

Connection of inductive load

A line break, the unplugging of a connector for inductive load, e. g. magnetic valves, contactors etc. or the volitional interrupting by a mechanical contact causes very high interference levels. These levels can be spread by galvanic, inductive or capacitive coupling in the system and potentially lead to malfunctions of the installation or other installations. To damp this interference level, a corresponding suppressor element (free-wheeling diodes, varistors, RC elements) are provided directly at the inductive load. Particularly then, if a switch is provided in series to the inductive load, e. g. for safety interlocks, you must not abandon a suppressor circuit.

All standard suppressor elements can be used.

GND breakage

If the GND line to the function module breaks, a leakage current of up to 25 mA per output might flow. In the case of parallel connected outputs the current multiplies accordingly.

Thus, there will be no reliable protection from GND breakage.

Peripheral Voltage X1S

The following values of the peripheral voltage comply with DIN EN 61131-2:

Nominal value	24 VDC
Tolerances	-15 % / +20 % (without residual ripple)
Residual ripple	+ / - 5 %
U _{max}	30 V
U _{min}	19.2 V
Current consumption	Max. 4 A

Fig. 7-47: Peripheral voltage according to DIN EN 61131-2

External power supply unit

The power supply unit must be safety-separated in accordance with DIN EN 50 178, section 5.2.18.1. Transformers must be designed with safety separation in accordance with DIN EN 60 742.

If these requirements are complied with, the 24 V supply voltage is rated as safety-separated extra-low voltage in accordance with DIN EN 50 178, section 5.2.8.1. This voltage is designed either as safety extra-low voltage (SELV) without ground connection of the reference conductor or as protective extra-low voltage (PELV) with ground connection of the reference conductor.

A three-phase power supply unit with easy full-bridge rectification is appropriate. The ripple voltage content must not exceed 5 %.

All 24 V voltage supply lines have to

- be laid such that they are isolated from lines carrying higher voltages, or
- be insulated to a particularly high degree, with the insulation having to be designed for the highest voltage present (see EN 60 204-1: 1997, section 14.1.3).

Any peripherals, such as digital sensors/actuators, which are connected to the interfaces of the function module, have to comply also with the criteria of safety-separated circuits.

CFL01.1-N1 Cam Switch Function Module

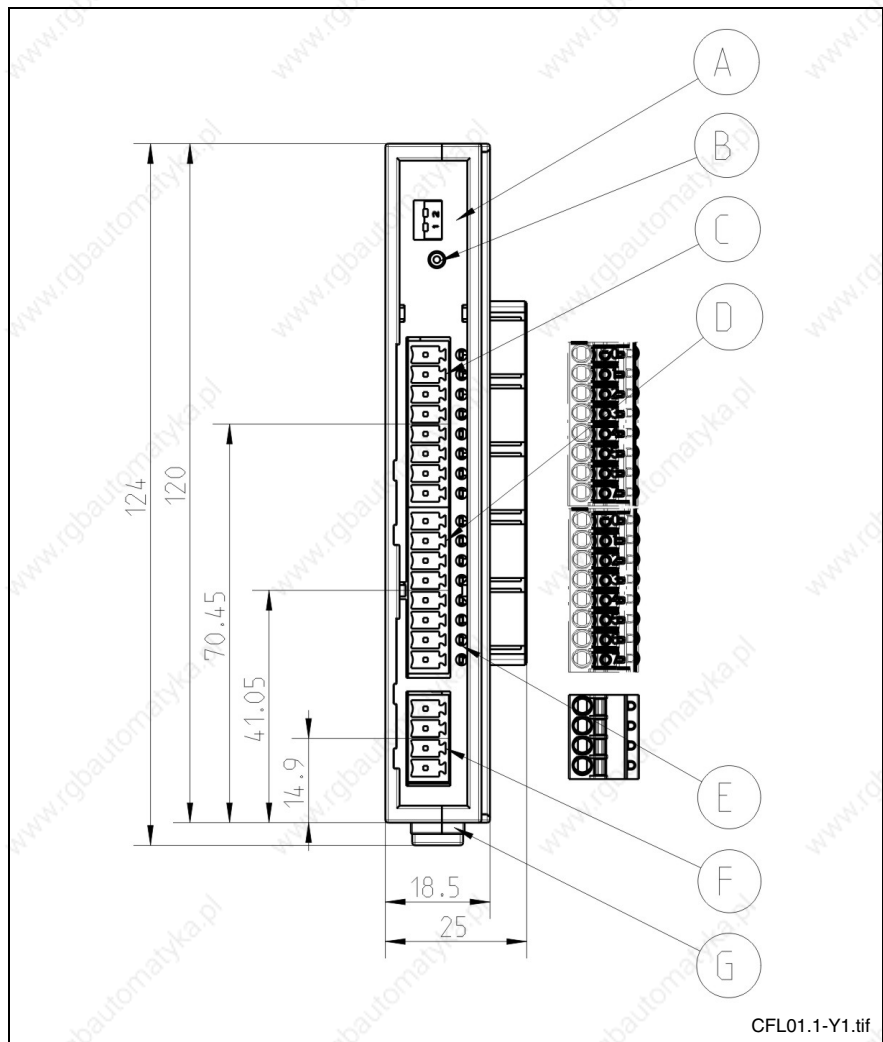

- A S1, switch for slot number
- B Stat, status display
- C X2O1, digital outputs
- D X2O1, digital outputs
- E Status LED of the outputs
- F X1S, load supply of the outputs
- G Mounting rail interlock

Fig. 7-48: Cam switch function module

Properties Each cam switch function module (also named as **Programmable Limit-Switch**, function module PLS) is equipped as follows:

- 16 outputs
- 2 MINI COMBICON plug and socket connections each with 8 outputs (X2O1 and X2O2)
- 1 MINI COMBICON plug and socket connection with power supply and functional earth ground
- LED status indicator for each output
- LED status indicator power fail and overload
- current per output is 250 mA when nominal voltage is 24 V (see note)

Note: The maximum current consumption per output is limited to 500 mA. However, the total of all output currents must not exceed 4 A.

Interfaces

Output connector X2O1 connection	Output connector X2O2 connection
Output 0	Output 0
Output 1	Output 1
Output 2	Output 2
Output 3	Output 3
Output 4	Output 4
Output 5	Output 5
Output 6	Output 6
Output 7	Output 7

Fig. 7-49: Output connectors X2O1 and X2O2

Feeder connector X1S connection
24 V (+)
GND (-)
FE
FE

Fig. 7-50: Feeder connector X1S

Note: The function module must be grounded with two 1.5 mm² conductors at the FE plug and socket connections. These conductors must have a length of maximum 1 m.

The FE functional earth ground is intended to discharge disturbances. It is not provided as a protection against electric shock for persons.

Indicators

The status LED shows three states:

Light-emitting diode Stat	Meaning
Green	Supply voltage available.
Red	Short-circuit or overload.
Off	Supply voltage of the control is missing.

Fig. 7-51: States of the status LED

Light-emitting diodes indicating the current status of the outputs are arranged besides the output terminals. They are connected on the quiet side and thus do not indicate the current output voltage.

Wiring the Module

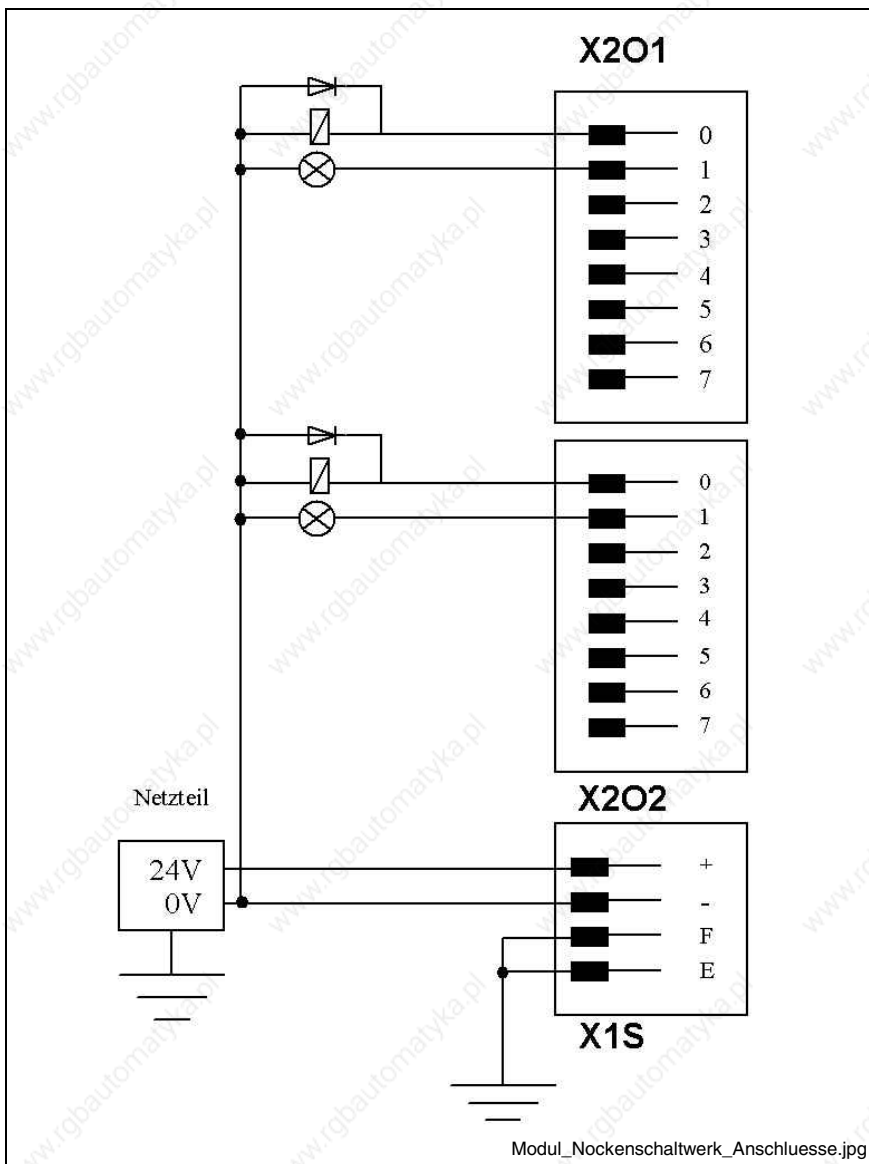

Fig. 7-52: Wiring the module



WARNING

Destruction of the module by improper connection!

- ⇒ Avoid polarity reversal with simultaneous short-circuit of the output lines
- ⇒ Avoid polarity reversal with simultaneous connection of externally polarized suppressor diodes
- ⇒ Do not apply an external voltage greater than the supply voltage

**WARNING****Damages of the module!**

- ⇒ If the maximum permissible current consumption of the function module is exceeded, components of the module can be destructed
- ⇒ Removing and inserting the spring terminals under voltage can damage the electrical contacts

Digital Outputs

Number of outputs	16
Connection method	1-wire connection
Output type	<ul style="list-style-type: none"> • Semiconductor outputs, non-saving • Protected, with automatic restart • Current-carrying
Electrical isolation to the logic supply	Yes
Output voltage, nominal value	24 V
Rated output current:	
Nominal value	0.5 A
Maximum value according to DIN EN 61131-2	≤ 0.6 A
1-signal	2 mA ... 0.6 A
0-signal (leakage current)	≤ 0.5 mA
UL rating:	
• General Purpose	0.5 A
• Tungsten	5 W
Parallel connection of outputs	Yes, but only within one half byte (0-3;4-7 etc.)
Maximum total current of outputs	4 A
Output delay time (ohmic load)	< 100 µs
Contact size (at 1 Hz) (inductive load)	SG1 (6.2 W)
Lamp load (at 8 Hz)	5 W
Overload protection:	
• Typical current level, causing switch-off	1.2 A
• Minimum current level, causing switch-off	0.6 A
• Automatic restart with reduced load	After approx. 10 ms
Overload indicator	Red stat. LED for all 16 outputs
Voltage reduced on circuit interruption in the nominal operating mode, limited to	Electronically limited to (Vext – 50 V) Typ. 26 V
Reverse voltage protection	Ensured without connected load
Supply voltage according to EN 61131-2	24 V DC
Open-circuit power consumption from 24 V	Typ. 50 mA
Cable length (unshielded)	< 100 m

Fig. 7-53: Data of digital outputs

Connection of inductive load

A line break, the unplugging of a connector for inductive load, e. g. magnetic valves, contactors etc. or the volitional interrupting by a mechanical contact causes very high interference levels. These levels can be spread by galvanic, inductive or capacitive coupling in the system and potentially lead to malfunctions of the installation or other installations. To damp this interference level, a corresponding suppressor element (free-wheeling diodes, varistors, RC elements) are provided directly at the inductive load. Particularly then, if a switch is provided in series to the inductive load, e. g. for safety interlocks, you must not abandon a suppressor circuit.

All standard suppressor elements can be used.

GND breakage

If the GND line to the function module breaks, a leakage current of up to 25 mA per output might flow. In the case of parallel connected outputs the current multiplies accordingly.

Thus, there will be no reliable protection from GND breakage.

Peripheral Voltage X1S

The following values of the peripheral voltage comply with DIN EN 61131-2:

Nominal value	24 VDC
Tolerances	-15 % / +20 % (without residual ripple)
Residual ripple	+ / - 5 %
U _{max}	30 V
U _{min}	19.2 V
Current consumption	Max. 4 A

Fig. 7-54: Peripheral voltage according to DIN EN 61131-2

External power supply unit

The power supply unit must be safety-separated in accordance with DIN EN 50 178, section 5.2.18.1. Transformers must be designed with safety separation in accordance with DIN EN 60 742.

If these requirements are complied with, the 24 V supply voltage is rated as safety-separated extra-low voltage in accordance with DIN EN 50 178, section 5.2.8.1. This voltage is designed either as safety extra-low voltage (SELV) without ground connection of the reference conductor or as protective extra-low voltage (PELV) with ground connection of the reference conductor.

A three-phase power supply unit with easy full-bridge rectification is appropriate. The ripple voltage content must not exceed 5 %.

All 24 V voltage supply lines have to

- be laid such that they are isolated from lines carrying higher voltages, or
- be insulated to a particularly high degree, with the insulation having to be designed for the highest voltage present (see EN 60 204-1: 1997, section 14.1.3).

Any peripherals, such as digital sensors/actuators, which are connected to the interfaces of the function module, have to comply also with the criteria of safety-separated circuits.

8 Installation and Maintenance

8.1 Mechanical Installation of the IndraControl L40

Mounting Rail (Top-Hat Rail) Mount the IndraControl L40 to a mounting rail (standard top-hat rail) according to DIN EN 50022 (35 mm x 7.5 mm).

Notes: Ensure that the top-hat rail is attached such that it provides appropriate rigidity.

Note: In addition to its holding function, this top-hat rail also assumes the function of ground connection and heat removal.

- For that reason, the top-hat rail must be connected to a functional earth ground.
 - Ensure a well heat-dissipating connection to the rear panel of the switch cabinet.
-

Install the IndraControl L40 horizontally in a switch cabinet or an appropriate housing.

If permitted by ambient conditions, the IndraControl L40 can also be mounted directly to the system.



CAUTION

Do not mount controls, modules or connectors while the unit is live!

⇒ Before mounting or dismounting components of the station, deenergize the entire station and the components. Connect the voltage only after you have set up the entire station. Any non-observance of this requirement may cause destruction of components.

Mounting the IndraControl L40

Mounting the IndraControl L40 to the Top-Hat Rail

Mount the IndraControl L40 by hanging it onto the top-hat rail from above and then exerting slight pressure to engage the control in the lower section of the housing.

Mounting Rexroth Inline Modules in Series

If necessary, mount Rexroth Inline modules in series with the control. For more detailed information, please refer to section "Mechanical Installation of Rexroth Inline Modules" on page 8-5.

End Plate

The end plate **must** form the mechanical termination to the right of the station, irrespective of whether you have mounted Rexroth Inline modules in series or not. The end plate does not have any electrical function. It is intended to protect the station from ESD pulses and the user from dangerous contact voltages. The end plate is included in the scope of delivery of the IndraControl L40. It is, therefore, not necessary to order the end plate separately.

Mounting the Function Modules

Thereafter, place - if necessary - the function modules onto the top-hat rail to the left of the IndraControl L40.

Set Slot Number

Corresponding to the particular module slot the slot number has to be set at DIP switch S1 (see Fig. 8-1).

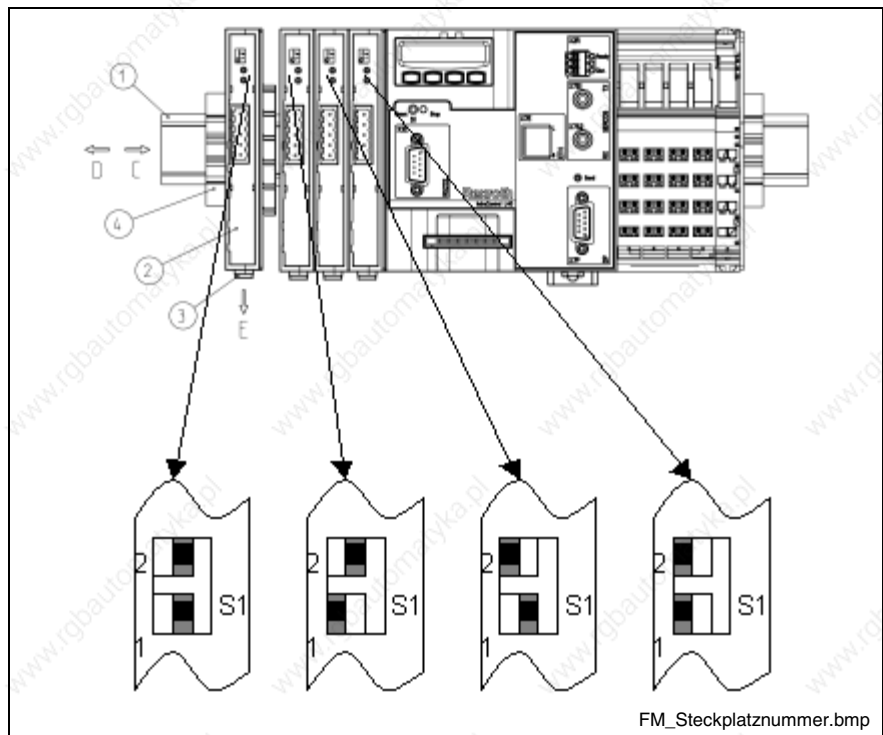

Fig. 8-1: Module slot and slot number of function modules

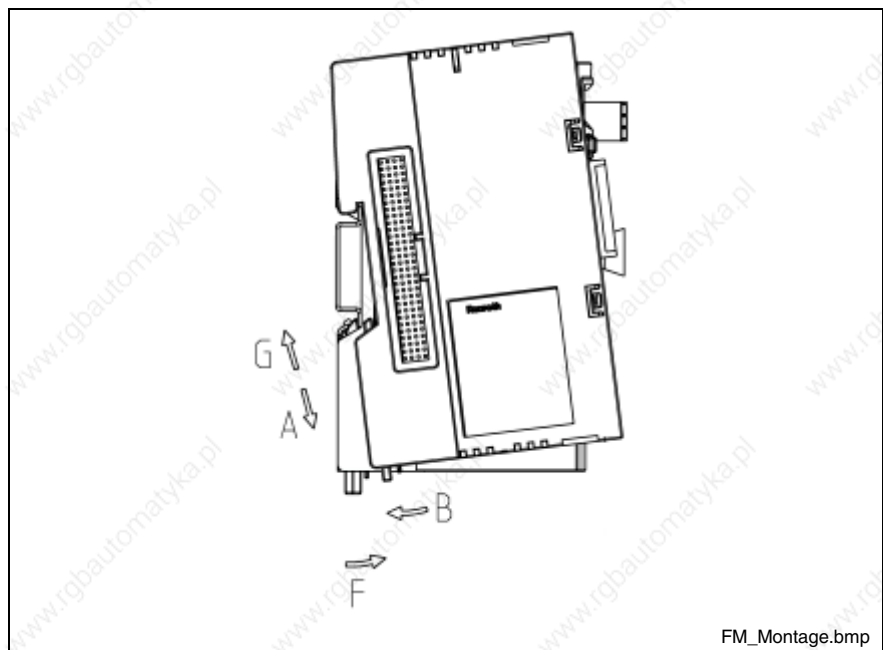

Fig. 8-2: Fitting and removing a function module

Fitting a Function Module

The function modules are fitted on the left 120-pin female connector of the IndraControl L40.

Hang the function module (2) onto the mounting rail (1,A) and tilt it (B) to the mounting rail until the interlock (3) snaps in.

Then, slide (C) the module on the left 120-pin female connector until a safe connection via the PCI^{PLUS} bus is established. If necessary, proceed in the same manner with further function modules that are mounted in series.

Adjust the function module with the end clamp (4) on the mounting rail.

- Removing a Function Module** Remove the end clamp (4).
Pull the function module to the left (D) away from the control or the neighboring module.
Pull down the mounting rail interlock (3) with a screw driver and tilt the function module forwards (F).
A circulation of the surrounding air has to be ensured.
If there are several rows of function modules, the supply air has to be measured under each row and its limit value has to be kept.
- Minimum Distances** The following minimum distances have to be realized:
30 mm to the left and right side measured from the outer edge of the control or the end plate behind the last Rexroth Inline disk.
100 mm upwards and downwards measured from the outer edge of the control.
At least 30 mm forwards measured from the outer edge of the control.
Additionally, the clearance for mounting, dismounting, connectors and cable outlets has to be provided.
- Attaching the End Clamps / CLIPFIX Clamps** Attach the end clamps to either side of the Rexroth Inline station. These end clamps ensure that the station is securely mounted to the top-hat rail and are also provided as lateral termination elements. These termination elements are included in the scope of delivery of the IndraControl L40.

Dismounting the IndraControl L40

- Disconnecting the Additional Modules from the IndraControl L40** To dismount the IndraControl L40, first disconnect the additional modules mounted to the left of the IndraControl L40 from the latter. First remove the left-hand end clamp (CLIPFIX) and slide the additional modules along the top-hat rail to the left until you have severed the plug connection of the PCI^{PLUS} bus.
- Removing the First Rexroth Inline module** Thereafter, remove the first Rexroth Inline module that is mounted to the right of the IndraControl L40. Proceed as follows:
- Remove the labeling field, if present.

Note: If any of the modules is provided with more connectors than one, all these connectors must be removed from the module.

- Pry out the connector of the module to be removed by pressing on the rear connector shaft latch.
- Remove the connector(s).
- Remove the power connector from the IndraControl L40. This ensures that the feathers of the voltage jumpers and the keyway/feather key connection are prevented from damage. Moreover, the module can be accessed more easily.
- Actuate the release mechanism (1 in Fig. 8-3) and remove the electronic socket perpendicularly to the top-hat rail (2 in Fig. 8-3).

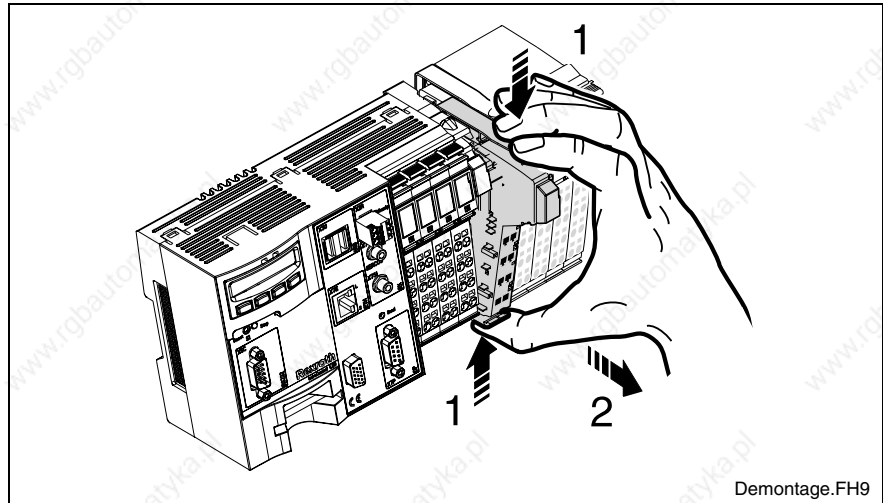

Fig. 8-3: Before dismantling the IndraControl L40, the first Rexroth Inline module must be removed.

Removing the IndraControl L40 from the Top-Hat Rail

You can now remove the IndraControl L40 from the top-hat rail by loosening the fixing claw on the bottom side by means of a tool (screwdriver) and pulling the IndraControl L40 off the top-hat rail from below, tilting it and removing it upwards.

8.2 Mechanical Installation of Rexroth Inline Modules

Rexroth Inline modules can be added in series to the right of the IndraControl L40 as appropriate. No tool is required. On connecting these modules in series, the potential and bus signal connection (voltage and data routing) between the individual components of the station is established automatically.

The modules must be mounted perpendicularly to the top-hat rail.

Once the station has been set up, individual modules can be replaced subsequently by being pulled out or plugged in without any additional tools.

Top-Hat Rail The Rexroth Inline modules must be mounted to the right of the IndraControl L40 on the 35 mm standard top-hat rail.

Mounting the Inline Modules

Proceed as follows to latch on a module (Fig. 8-4):

- First latch on the electronic sockets, which are required to set up the station, perpendicularly to the top-hat rail (Fig. A).

Note: Ensure that **all** feather keys and keyways of neighboring modules are interlocked (Fig. B).

The keyway/feather key connection connects neighboring modules to each other and ensures, that the voltage jumper is set up securely.

- Then fit the connectors onto the pertinent sockets.

First fit the forward connector shaft latch in the forward release mechanism (Fig. C).

Then press the connector towards the socket until it clicks into place in the rear release mechanism (Fig. D).

Note: The keyways provided in the electronic socket are not continued in the connector. An electronic socket can only be latched on, if there is no connector to the left of it. If necessary, the latter must be removed.

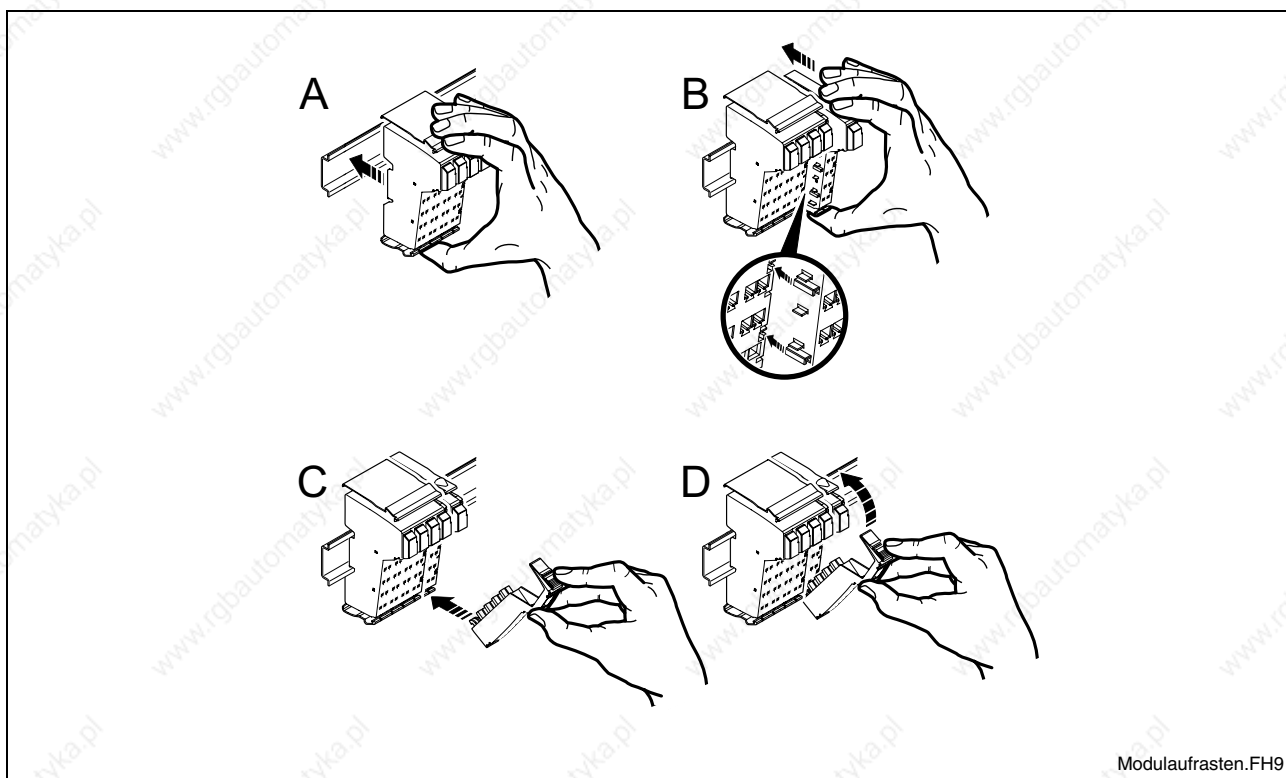

Fig. 8-4: Latching on a module

Dismounting the Inline Modules

Proceed as follows to remove a module (Fig. 8-5):

- Remove the labeling field, if present (A1 in Fig. A).

Note: If any of the modules is provided with more connectors than one, all these connectors must be removed from the module. The sections below describe the removal of a 2-slot module.

Pry out the connector of the module to be removed by pressing on the rear connector shaft latch (A2 in Fig. A).

- Remove the connector (Fig. B).
- Remove the adjacent connectors of the neighboring modules (Fig. C). This ensures that the feathers of the voltage jumpers and the keyway/feather key connection are prevented from damage. Moreover, the module can be accessed more easily.
- Actuate the release mechanism (D1 in Fig. D) and remove the electronic socket perpendicularly to the top-hat rail (D2 in Fig. D). If you have failed to loosen the connector of the neighboring module to the left, this connector now comes loose to protect the feathers of the voltage jumper and the keyway/feather key connection.

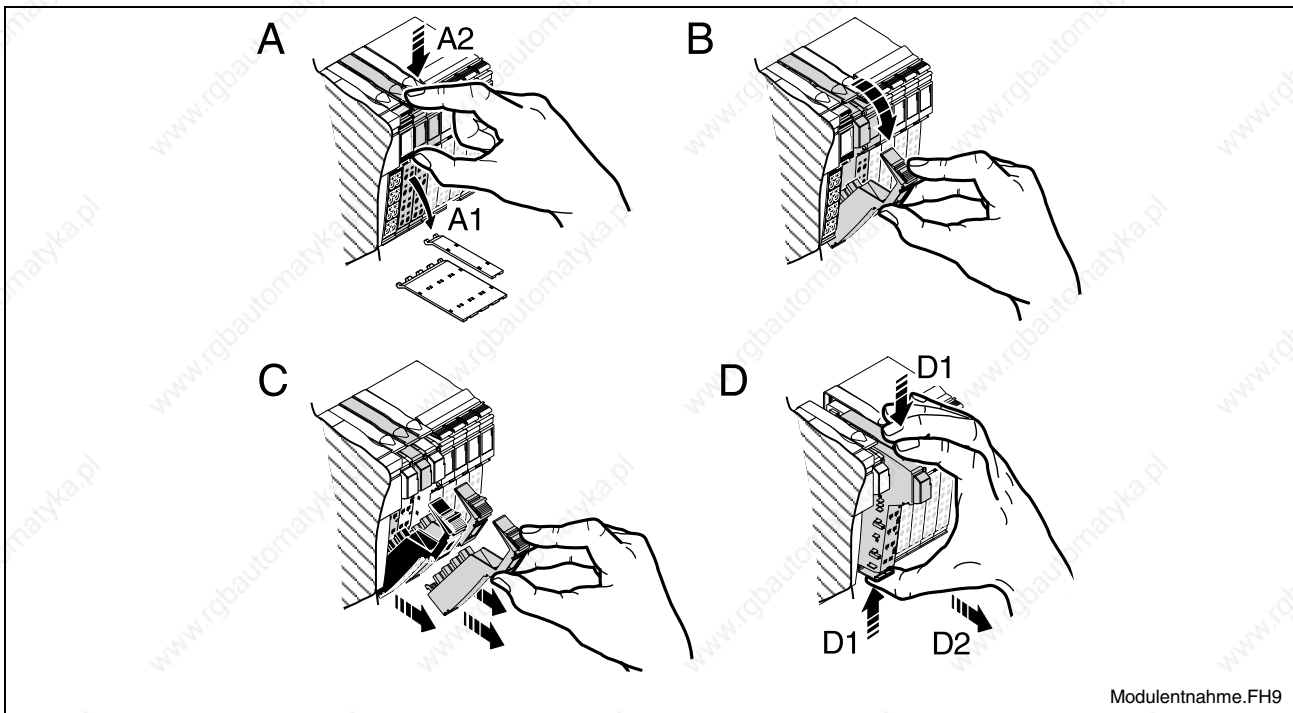

Fig. 8-5: Removing a module

Replacing a Module

If you intend to replace a module within the Rexroth Inline station, proceed as described above to remove it. Do not latch on the adjacent connector of the neighboring module to the left yet.

Insert the socket of the new module. Refit all connectors.

Fuse Replacement

If segment terminals with fuse are used, the connected voltage and the state of the fuse are monitored and indicated by diagnostic indicators (see the chapter entitled "Indicators on the Supply Terminals" on page 9-15).

Note: A missing fuse must be installed; a defective fuse must be replaced.

When replacing the fuse, please observe the following instructions on the safety of your health and the protection of your station!

1. Always use the screwdriver with care to prevent yourself and any other person from being injured.
2. Pry out the fuse at the metal contact. Do not pry the fuse out at the glass body to prevent the latter from being broken.
3. Pry out the fuse carefully on one side and then remove it by hand. Take care not to drop the fuse into your station.

Proceed as follows to replace the fuse (also see the illustrations in Fig. 8-6):

- Swing up the fuse lever (Fig. A).
- Put a screwdriver behind a metal contact of the fuse (Fig. B).
- Carefully pry out the metal contact of the fuse (Fig. C).
- Remove the fuse by hand (Fig. D).
- Latch in the new fuse (Fig. E).
- Press the fuse lever down again until it clicks into place (Fig. F).

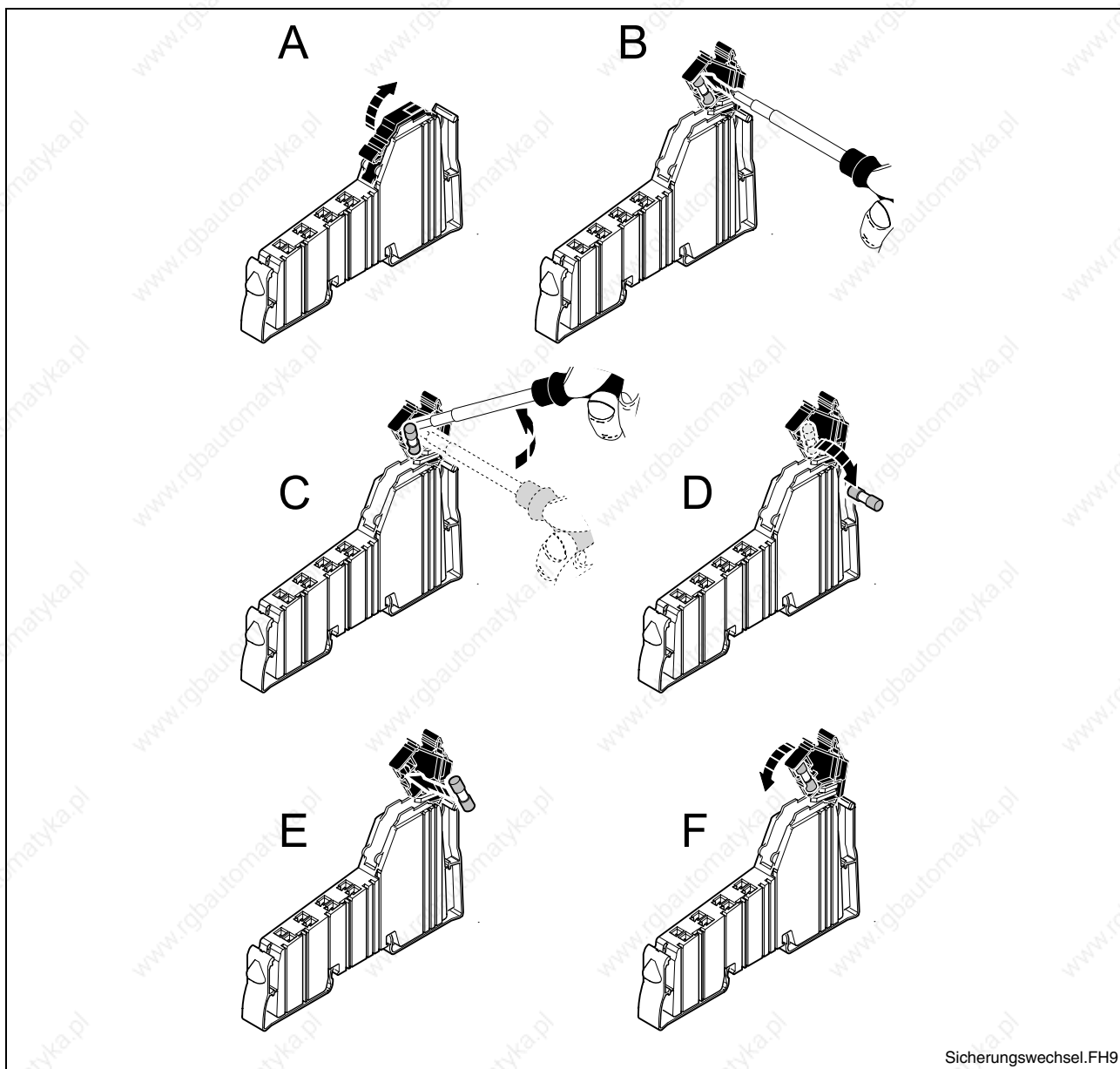

Fig. 8-6: Fuse replacement

8.3 Electric Installation

The following rules for setting up a system, in which the electrical equipment like control systems are used, must be adhered to:

- DIN VDE 0100
- DIN EN 60 204-1
- DIN EN 50 178



DANGER

Danger of personal injury and material damage!

- ⇒ Any dangerous states of the system which might cause personal injury or material damage must be prevented!
- ⇒ The rules and regulations for setting up EMERGENCY STOP equipment in accordance with EN 60 204-1 must be adhered to!
- ⇒ Any automatic restart of machines after power return, e. g. after an EMERGENCY STOP, must be excluded!
- ⇒ Protection for direct and indirect contact must be ensured by the measures prescribed (connection to protective conductor, isolation, etc.).

External Power Supply Unit

All components of the IndraControl L40 are supplied with 24 V supply voltages.

The power supply unit must be safety-separated in accordance with DIN EN 50 178, section 5.2.18.1. Transformers must be designed with safety separation in accordance with DIN EN 60 742.

If these requirements are complied with, the 24 V supply voltage is rated as safety-separated extra-low voltage in accordance with DIN EN 50 178, section 5.2.8.1. This voltage is designed either as safety extra-low voltage (SELV) without ground connection of the reference conductor or as protective extra-low voltage (PELV) with ground connection of the reference conductor.

A three-phase power supply unit with easy full-bridge rectification is appropriate. The ripple voltage content must not exceed 5 %.

All 24 V voltage supply lines have to

- be laid such that they are isolated from lines carrying higher voltages, or
- be insulated to a particularly high degree, with the insulation having to be designed for the highest voltage present (see EN 60 204-1: 1997, section 14.1.3).

Any peripherals, such as digital sensors/actuators, which are connected to the interfaces of the IndraControl L40, have to comply also with the criteria of safety-separated circuits.

24 V Voltage Supply

Setup without Electrical Isolation

The most easiest connection method is the establishment of an electrical isolation between the internal logic and the peripheral supply.

In this case, a power supply unit is appropriate to supply the IndraControl L40. It is not permitted to use an autotransformer to ensure compliance with overvoltage category II.

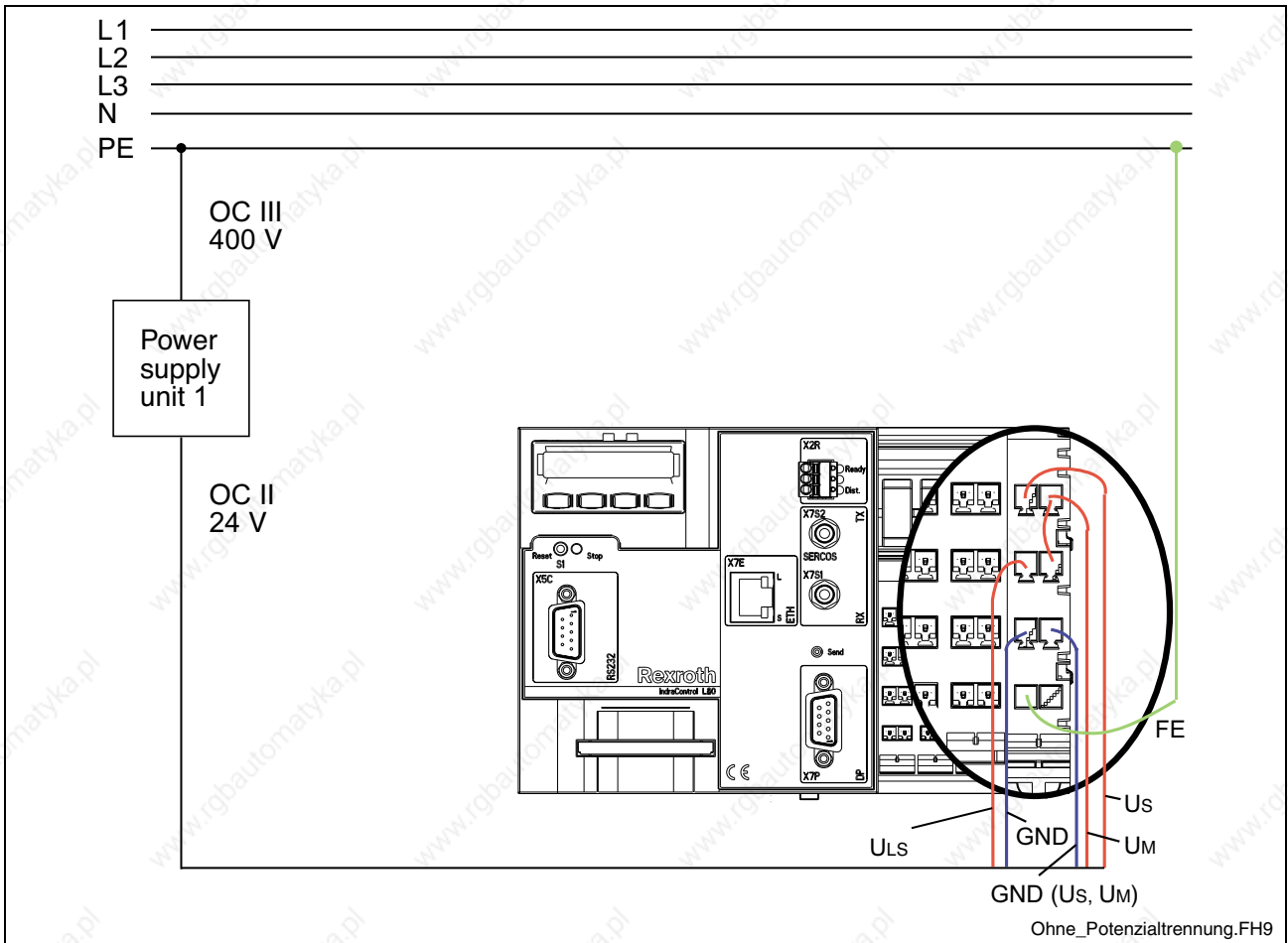

Fig. 8-7: Setup without electrical isolation

Setup with Electrical Isolation

According to DIN EN 60 204-1, electrical isolation should be provided between the logic of the central processing unit and the I/O interfaces of the peripheral assemblies. Accordingly, the voltage U_{LS} (24 V logic voltage) is electrically isolated from the voltages U_S (24 V segment voltage) and U_M (24 V main voltage) in the IndraControl L40.

The following is an example of a setup with electrical isolation:

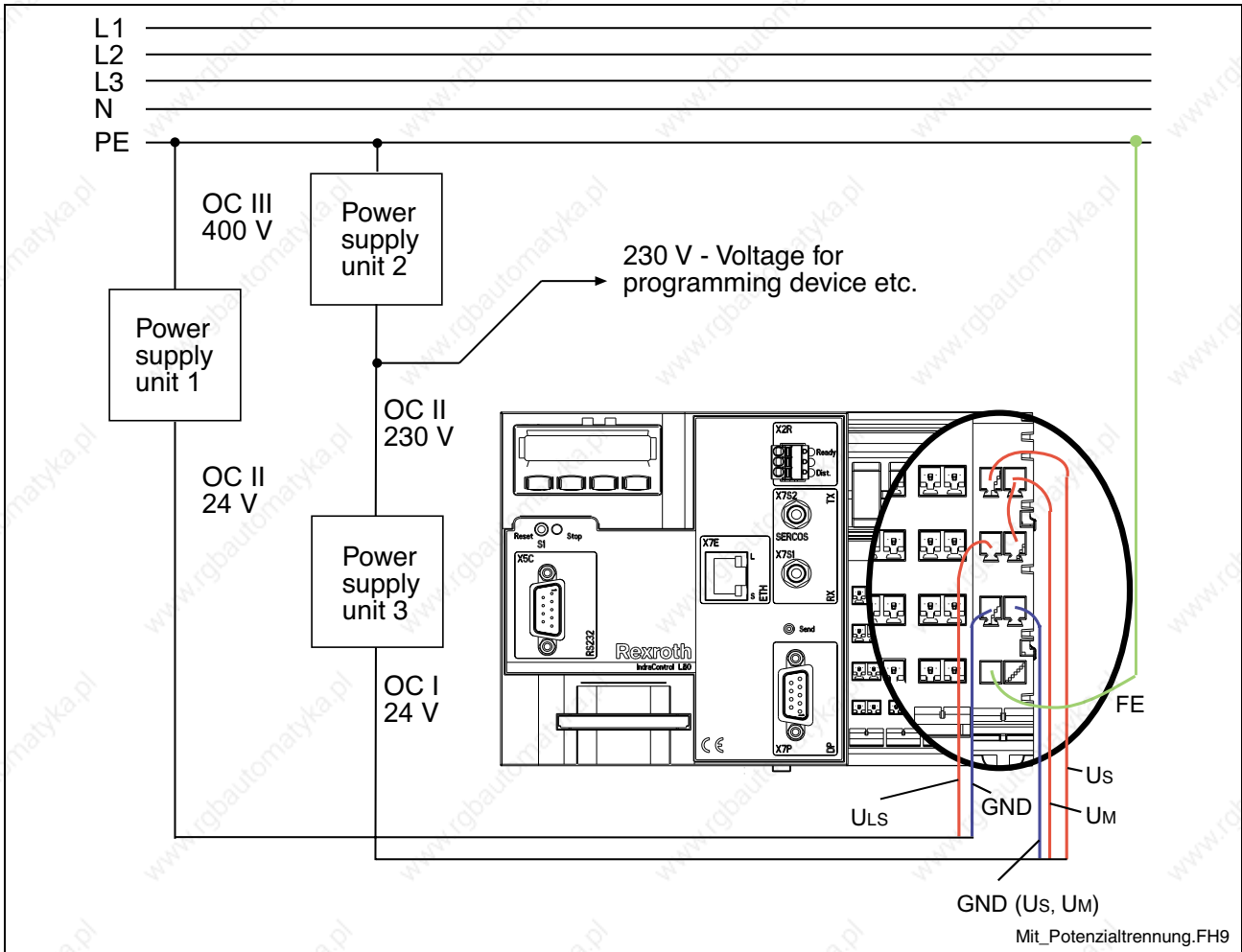

Fig. 8-8: Setup with electrical isolation

Reference Conductor Connected to the Protective Conductor

If the reference conductor (N, 0 V) is connected to the protective conductor system, then this connection must be arranged at a central point (e. g. at the load power supply unit or at the isolating transformer). In addition, it must be possible to break this connection for measuring ground leakage currents. Hence, the supply current circuit is a PELV circuit.

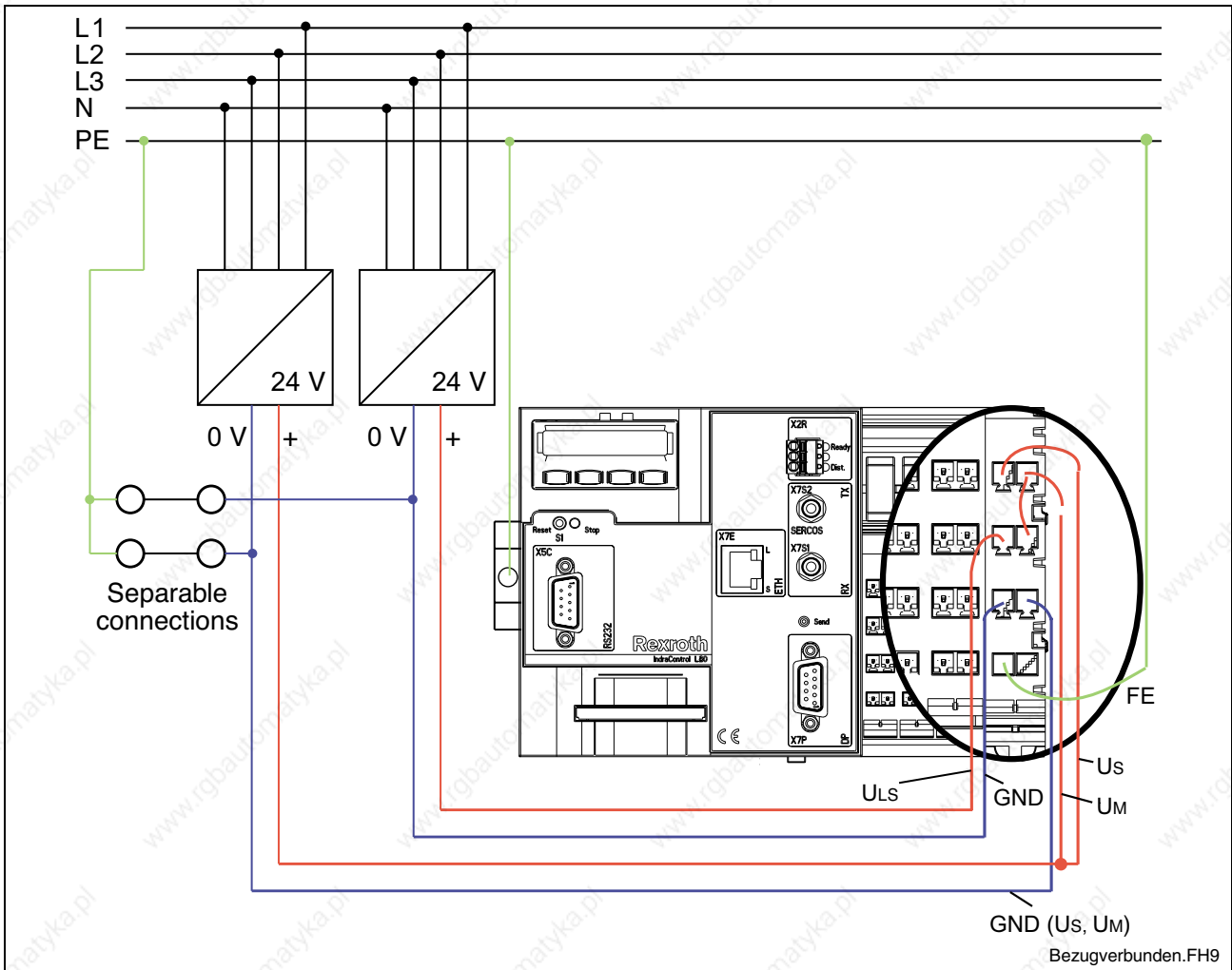

Fig. 8-9: Reference conductor connected to the protective conductor

Reference Conductor Not Connected to the Protective Conductor

If the reference conductor (N, 0 V) is not connected to the protective conductor system, then an appropriate ground fault detector must be used to prevent inadvertent power-up in case of insulation faults. Hence, the supply current circuit is a SELV circuit. Please note that any additionally connected equipment might also cancel the non-grounded setup.

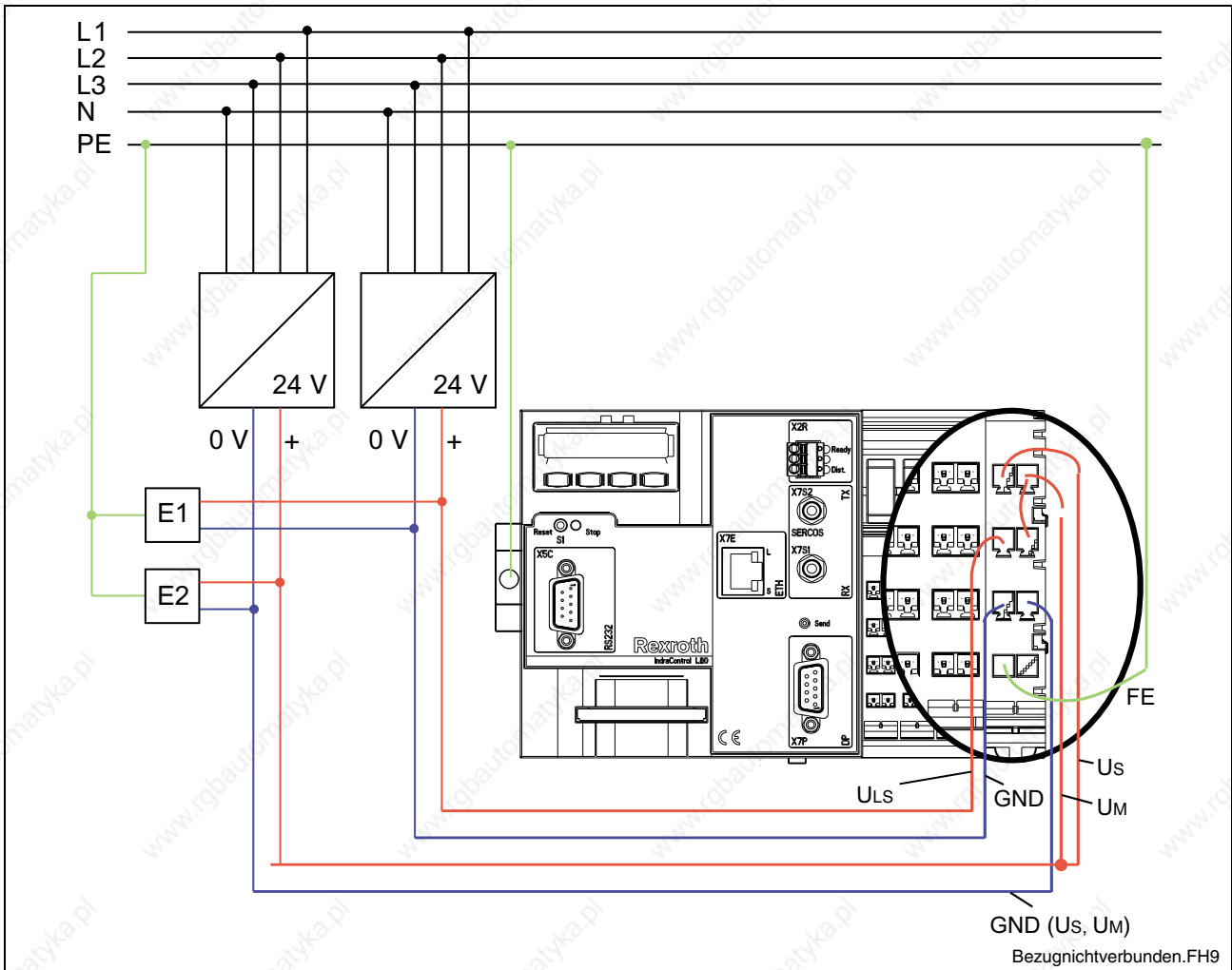

Fig. 8-10: Reference conductor not connected to the protective conductor

Programming Device and Ground Connection

Programming devices are almost always provided with a connection between the ground and the functional earth ground. This connection might give rise to problems, if the voltage supply of the IndraControl L40 is provided with a ground fault detector and the programming device is connected to the IndraControl L40. Owing to the non-isolated power supply unit assembly, the ground fault in the programming device has an effect on the ground fault detector via the central processing unit and the power supply unit assembly. In this case, the detector should not deactivate the system automatically, but only indicate the ground fault. Maintenance staff should be aware of this fact.

Dimensioning the Voltage Supply

When dimensioning the voltage supply, consider the maximum currents (see DIN VDE 0100-523). A voltage of 20.4 ... 28.8 V must be applied directly to the unit.

The voltage must be maintained even if

- there are variations in the line voltage, for instance caused by differing loads of the power supply network,
- there are varying load states, such as short-circuit, normal load, lamp load, or no load.

The maximum line cross-section for the voltage supply is 1.5 mm².

Main Switch and Fuses

Main Switch

A main switch according to DIN VDE 0100 must be provided for the IndraControl L40 as well as sensors and actuators.

Fuses

Fuses and circuit-breakers are intended to protect the supply lines in a network. The voltage supply lines of the IndraControl L40 must be protected by fuses. The sensor supply and the actuator supply should each be protected by a separate fuse. If the supply lines are shorter than 3 m and are placed such that they are protected from ground faults and short-circuits, it is not necessary to provide fuses.

Further criteria for the selection of protective devices are the following:

- Nominal voltage
- Temperature
- Internal fuse resistances
- Inrush currents
- Cable lengths
- External impedance of the power supply system
- Possible fault location
- Vibration

For additional information, please refer to:

Manual No. 32

VDE publications

Dimensioning and protecting lines and cables according to DIN 57 100, VDE 0100-430 and -523.

Appropriate information is also provided by many manufacturers of fuses and circuit-breakers.

Ground Connection

Functional Earth Ground

An optimum ground connection is required to keep possible interferences away from the IndraControl L40 and the Rexroth Inline modules and to discharge them to the ground.

The top-hat rail used for mounting the IndraControl L40 must be mounted to a grounded metal carrier, e. g. the rear panel of the switch cabinet.

A functional earth ground is required to ensure optimum noise immunity. The functional earth ground must be connected via a cable that should be as short as possible or, better, via a grounding strip.

Recommended value: Length: Max. 1 m
Cross-section: 6 mm²

Both the IndraControl L40 and the power and segment terminals are provided with FE springs (metal clips) at their bottom side, which establish an electric connection to the top-hat rail. To ensure a reliable ground connection even in case of dirt or a damaged metal clip, the IndraControl L40 must be additionally grounded via the FE terminal point, using a conductor with a cross-section of at least 1.5 mm².

The FE functional earth ground is intended to discharge disturbances. It is not provided as a protection against electric shock for persons.

Voltage Jumper

Starting at the IndraControl L40, the FE (functional earth ground) voltage jumper is routed through all connected Rexroth Inline modules. This ensures that these modules are grounded once the ground connection of the IndraControl L40, the supply terminals and the top-hat rail has been properly established.

Potential Equalization

Potential equalization according to DIN VDE 0100 Part 540 must be provided between the system parts and the voltage supply.

All components of the system must be connected to the PE protective conductor system at the connectors that are marked accordingly.

Shielding

The shielding is intended to reduce any effects of interferences on the system.

Both the PROFIBUS line and the connection lines to modules for analog signals must be shielded.

Observe the following when shielding:

- Fit the shield over an area as large as possible under the clip in the shield connector.
- Ensure proper contact between the connector and the module.
- Avoid damaging or squeezing of cores. Avoid stripping the lines too much.
- Connect the cores properly.

Shielding the PROFIBUS Line

The 0 V reference voltage of the connected loads must be returned to the 0 V terminal of the IndraControl L40, i. e. a two-pin connection must be ensured. Otherwise, there will be no reliable protection from GND breakage.

The cable parameters are described in the chapter entitled "Interfaces" on page 7-12.

The line shield must be applied in the bus connector. In case of installation in the switch cabinet, the line shield of the connected PROFIBUS line must be connected to a shield bus using cable clips, if possible directly behind the cable bushing. This requires the appropriate shield terminal.

Shielding in Case of Analog Sensors and Actuators

- Always connect analog sensors and actuators using shielded and twisted cable pairs.
- Connect the shield system via the shield connector.

Connection of the shield to the shield connector is described on page 8-19, "Connecting Shielded Lines Via the Shield Connector".

Depending on the analog input and output modules, there are several ways of grounding the shield. The length of the cables must also be taken into consideration.

Module type	Connection to the module	Cable length	Connection to the sensor/actuator
Analog input module R-IB IL AI 2/SF	Ground connections are connected to FE via an RC element inside the module.	< 10 m	–
		> 10 m	Apply the sensor directly to the PE.
Analog output module IB R-IL AO...	Directly on FE using a shield clip.	< 10 m	–
		> 10 m	Decouple the actuator with RC element and apply it to the PE.

Fig. 8-11: Overview: Shield connection of analog sensors and actuators

Connecting the Analog Input Module R-IB IL 24 AI 2/SF

- Connect the shield system via the shield connector (see page 8-19, "Connecting Shielded Lines Via the Shield Connector").
- Connect the shield system at the sensor to the FE potential over an area as large as possible.

The ground connection in the module is connected to FE via an RC element inside the module.

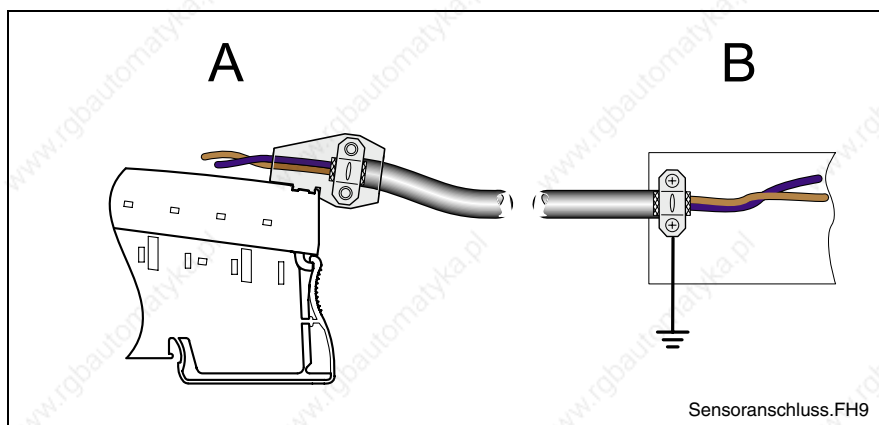

- L: A Module side
 B Sensor side

Fig. 8-12: Connection of analog sensors in case of signal lines > 10 m

Note: If you intend to use both channels of the module R-IB IL AI 2/SF, you may connect the shield system in several ways, depending on the line cross-section.

- 1 To connect the two sensors, you should use a multi-core line; connect the shield via the shield connector, as described above.
- 2 To connect the two sensors, you should use a thin line; connect the shield system for both lines via the shield connector.

Connecting the Analog Output Module R-IB IL AO ...

Note:

- Connect the shield system via the shield connector (see page 8-19, "Connecting Shielded Lines Via the Shield Connector").
- Connect the shield system to the FE potential over an area as large as possible.

Note:

Development of ground loops!

- ⇒ The shielding system may be connected directly to the ground potential at one point only.
- If lines are more than 10 meters in length, they should always be decoupled by means of an RC element (on the actuator side).

The typical value of the capacitor C should range from 1 nF to 15 nF. The value of resistor R should be at least 10 M Ω .

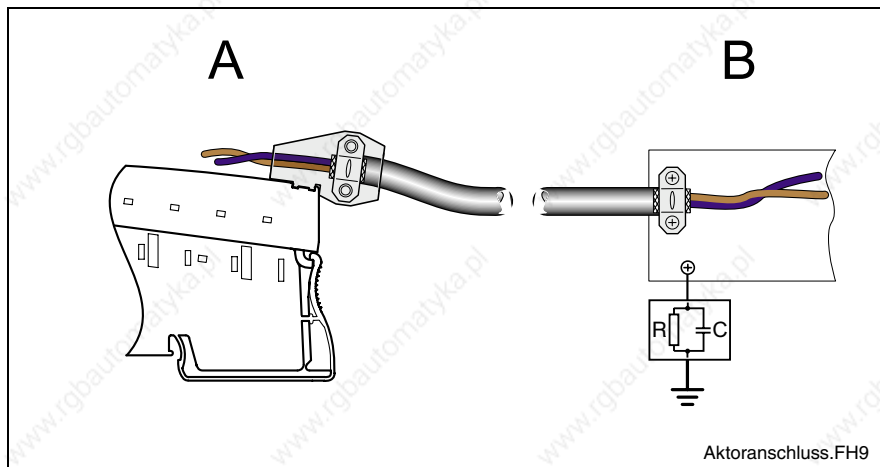

L: A Module side
 B Actuator side

Fig. 8-13: Connection of actuators, in case of signal lines > 10 m

Connecting Lines to Tension Spring Connection Points

Connect the lines for peripheral equipment and voltage supply to the tension spring connection points both at the IndraControl L40 and the Rexroth Inline modules.

Use unshielded lines for the digital inputs and outputs and the voltage supply. Use shielded lines to connect the analog inputs and outputs.

You can connect lines with a connection cross-section ranging from 0.2 mm² to 1.5 mm² (AWG 24 – 16). These lines permit the supply of signals of up to 250 V AC/DC and 5 A.

Connecting Unshielded Lines

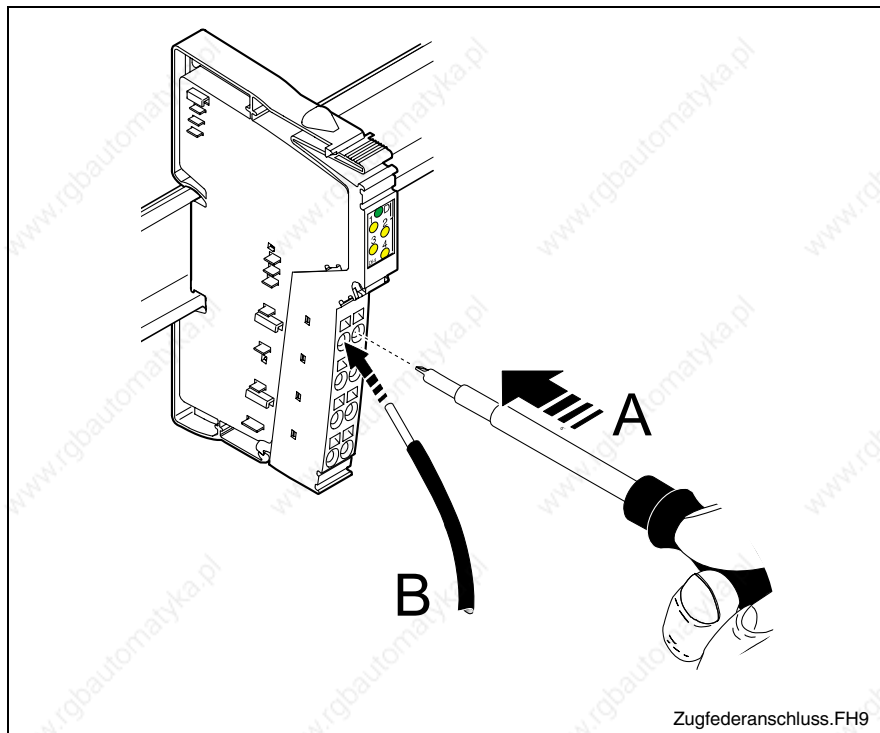

Fig. 8-14: Connecting lines to the tension spring connectors

Wire the connectors as required according to your application.

Proceed as follows to wire the connectors:

- Strip the line to a length of 8 mm. Wiring is provided without connector sleeves. However, connector sleeves may be used, if desired. In this case, the connector sleeves must be properly crimped.
- Put a screwdriver into the actuation slot of the appropriate terminal point (Fig. 8-14, A) as far as necessary to be able to insert the core into the opening of the spring. Insert the core (Fig. 8-14, B). Pull the screwdriver out of the opening. This fixes the core. We recommend to label both the cores and the terminal points after completed installation.

Note: For additional information on the connection method, please refer to Manual \2\ Rexroth Inline PROFIBUS DP; Application Manual (see chapter entitled "Further Documentation" on page 1-2).

Connecting Shielded Lines Via the Shield Connector

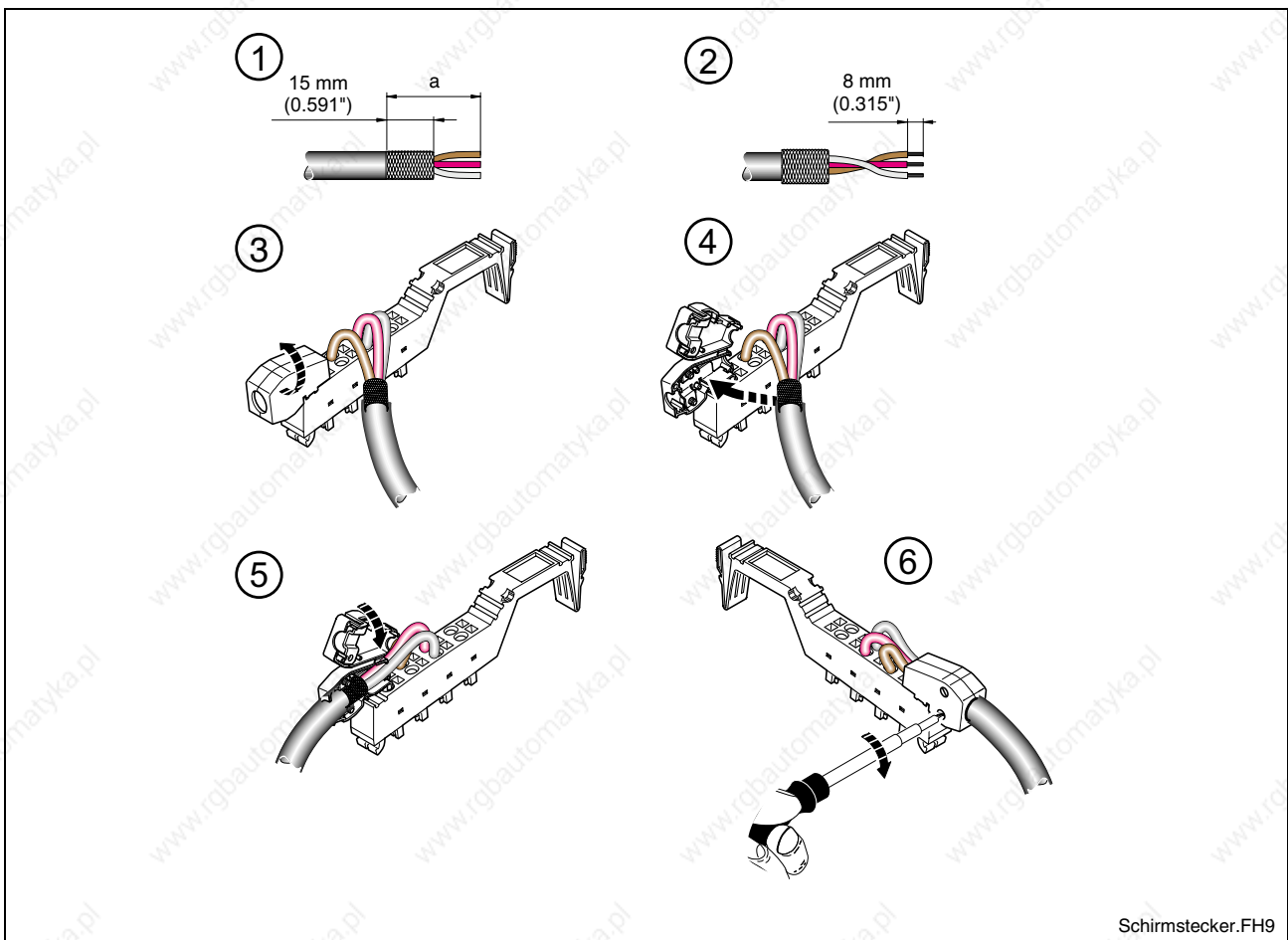

Schirmstecker.FH9

Fig. 8-15: Connecting the shield to the shield connector

Below, connection of a shielded line is described by example of an "analog line".

Proceed as follows:

Stripping the Lines

- Strip the outer sheath of the line to the desired length (a) (1).
The desired length (a) depends on the position where you connect the cores and on whether you intend to place the cores between the connection point and shield connection in a generous or a tight arrangement.
- Shorten the braid to 15 mm (1).
- Place the braid around the outer sheath (2).
- Remove the protective foil.
- Strip the lines for 8 mm (2).

Note: The Rexroth Inline wiring is provided without connector sleeves.

- Wiring the Connectors**
- Put a screwdriver into the actuation slot of the appropriate terminal point (Fig. 8-14, A) as far as necessary to be able to insert the core into the opening of the spring.
 - Insert the core (Fig. 8-14, B). Pull the screwdriver out of the opening. This fixes the core.
- Connecting the Shield**
- Please refer to the pertinent module-specific data sheet for information on the connector pin assignment .
- Open the shield connector (3).
 - Check the orientation of the shield clip in the shield connector (see Fig. 8-15).
 - Place the line including surrounding braid in the shield connector (4).
 - Close the shield connector (5).
 - Tighten the screws on the shield connector using a screwdriver (6).

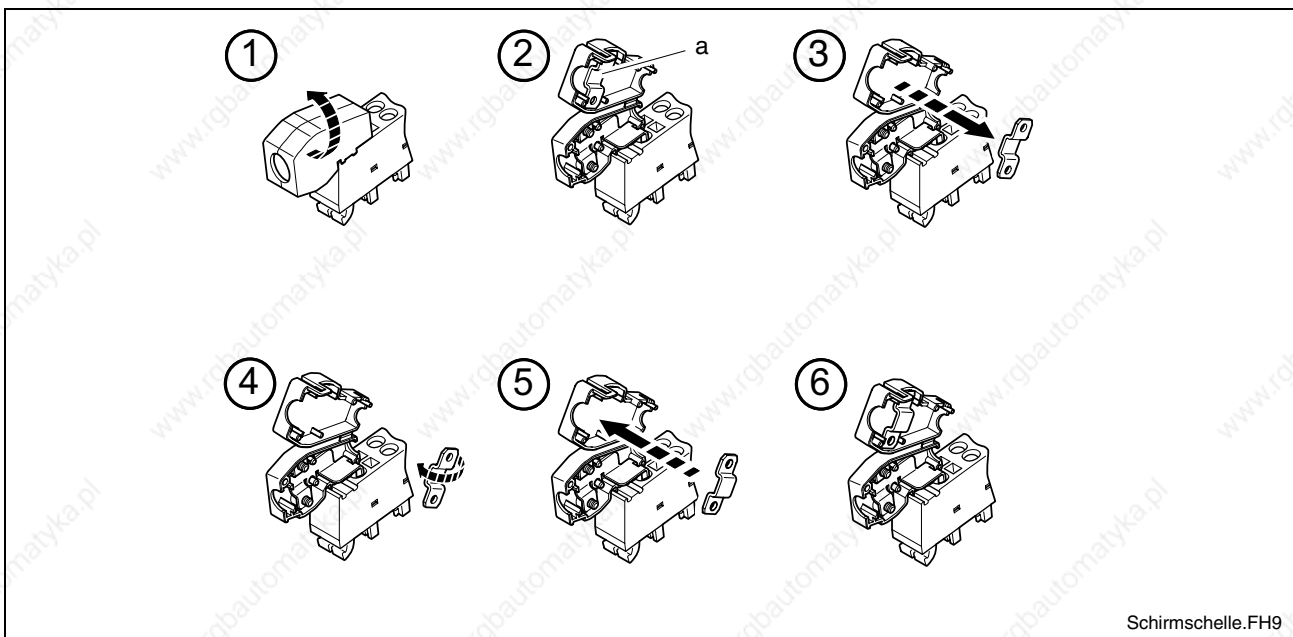

Fig. 8-16: Orientation of the shield clip

Shield Clip The shield clip (a in Fig. 8-16, 2) in the shield connector can be used according to the line cross-section. If thicker lines are used, the camber of the clip must be directed away from the line (Fig. 8-16, 2). If thinner lines are used, the camber of the clip must be directed towards the line (Fig. 8-16, 6).

If you have to change the orientation of the shield clip, proceed as described below and shown in Fig. 8-16:

- Open the housing of the shield connector (1).
- On delivery, the shield connector is intended for the connection of thicker lines (2).
- Remove the clip (3), turn the clip according to the cross-section of the line used (4), and fit the clip (5).
- Figure 6 illustrates the clip, if a thin line is used.

8.4 Maintenance

Include the following measures in your maintenance schedule:

- At least once a year, check all plug and terminal connections for proper tightness and damage. Verify that lines and cables are not broken or squeezed. Replace damaged parts immediately.

9 Structure of the Rexroth Inline Terminals

9.1 Basic Structure of Terminals of the Low Signal Level

Independently of its function and its overall width, a Rexroth Inline module of the low signal level consists of the electronic socket (in short: socket) and the plug-in connector (in short: connector).

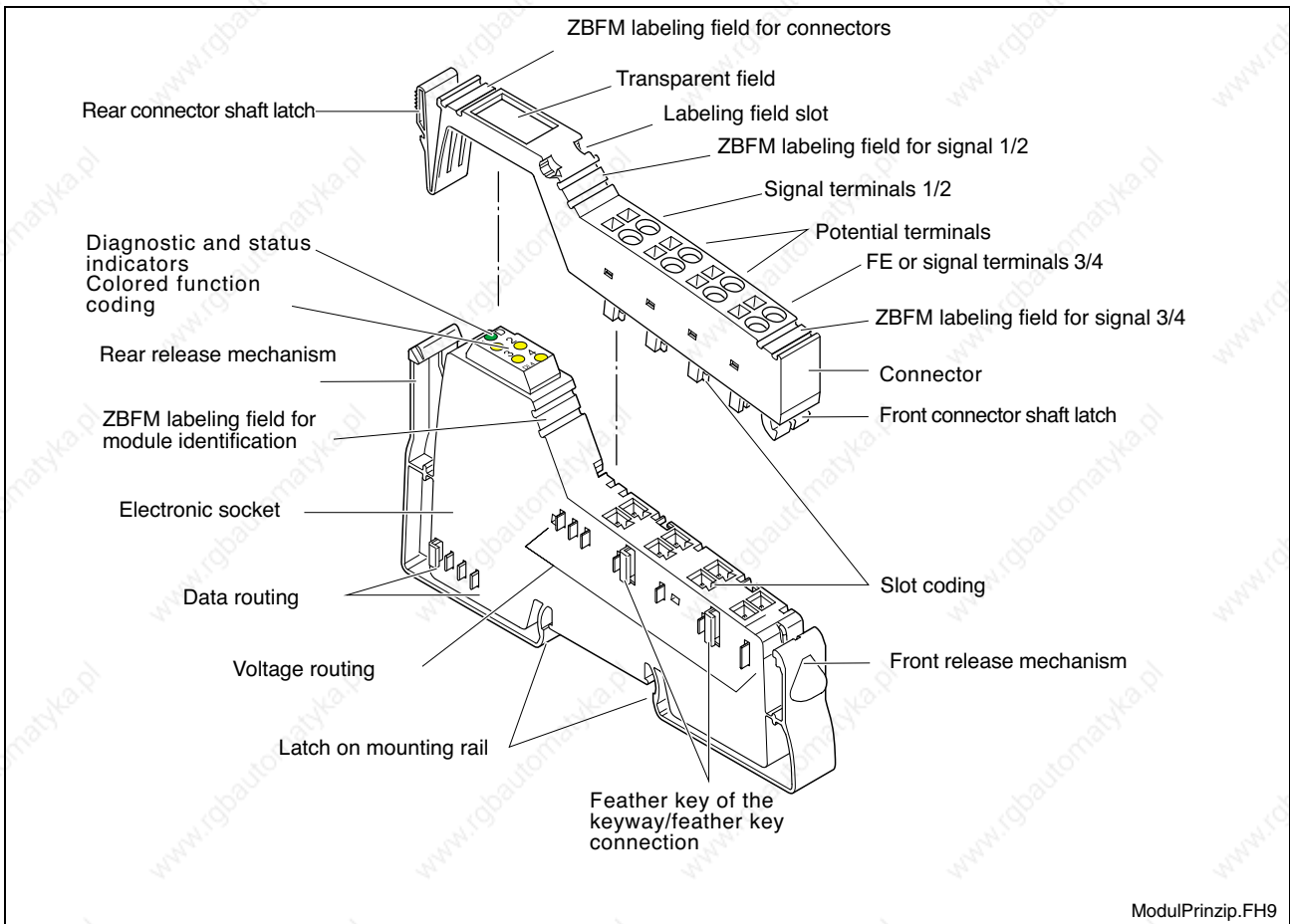

Fig. 9-1: Basic structure of a Rexroth Inline modules

The most important components of those shown in Fig. 9-1 are described in the chapters "Elektronic Socket" on page 9-1 and "Connectors" on page 9-2.

ZBFM: Zack marker strips, flat (also see the chapter entitled "Identification of Function and Labeling" on page 9-5).

9.2 Electronic Socket

All electronic parts of the Rexroth Inline module as well as the voltage and data jumpers are accommodated in the electronic socket.

Overall Widths

By default, the electronic sockets for terminals of the low signal level are available in terminal widths of 8 terminal points (8-slot connector) and 2 terminal points (2-slot connector). Any other dimensions are combinations of the two above mentioned basic terminal widths (also refer to the chapter entitled "Housing Dimensions of the Modules of the Low Signal Level" on page 9-8).

9.3 Connectors

The connection of the peripheral equipment or the supply voltages is provided in the form of a connector, that can be disconnected from the electronic socket.

Advantages This pluggable connection has the following advantages:

- Easy replacement of electronic module parts for servicing. The wiring does not have to be removed.
- For different requirements, different connectors can be fitted on an electronic socket.

Connector Width Irrespective of the width of the electronic socket, the connectors have a width of two terminal points. Accordingly, you must fit 1 connector on a 2-slot socket, 2 connectors on a 4-slot socket and 4 connectors on a 8-slot socket.

Connector Types The following connector types are available:

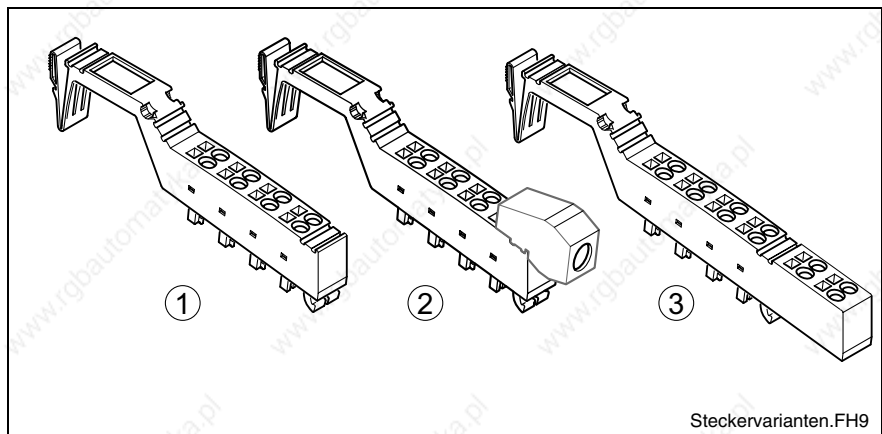

Fig. 9-2: Rexroth Inline connector types

Connector Identification All connectors are available with colored print. If connectors are provided with colored print, the terminal points are color-coded according to their functions.

The signals of the terminal points are coded by the following colors:

1 Standard connector

The gray standard connector is used for connecting two signals as 4-wire connection (e. g. digital input/output signals). The black standard connector is used for supply terminals. Its neighboring contacts are internally jumpered (see B1 in Fig. 9-4). Connector B2 (FE jumpered only) must be used for the supply terminal of the IndraControl L40.

2 Shield connector

This gray connector is used for signals connected via shielded lines (e. g. analog input/output signals). The FE and/or shielding connection is not provided through terminal points, but through a shield clip.

3 Extended double-signal connector

This gray connector is used for connecting four signals as 3-wire connection (e. g. digital input/output signals).

Color	Signal at the terminal point
Red	+
Blue	-
Green / yellow	Functional earth ground

Fig. 9-3: Color-coding of the terminal points

Interior Design of the Connectors

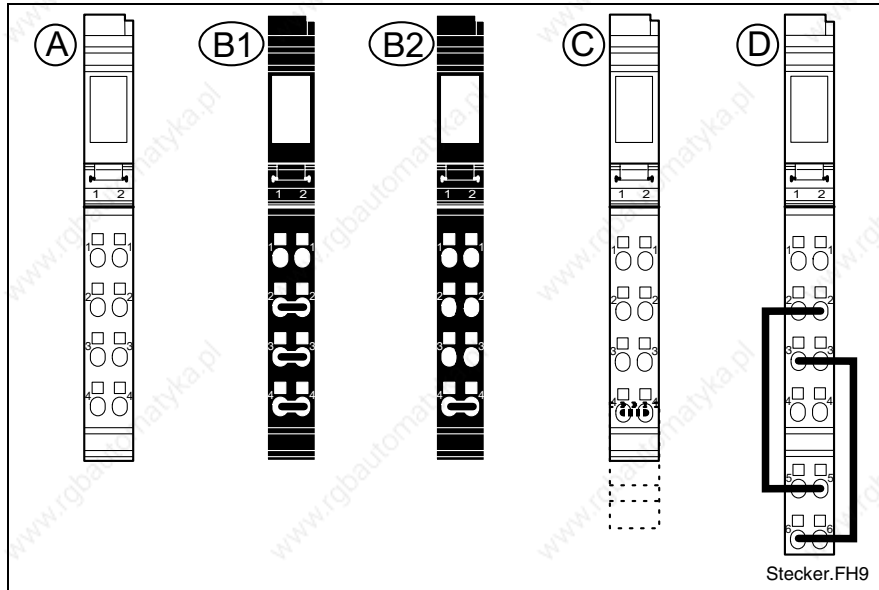

- L: A Gray connector for peripheral connection
 B1 Black connector for PWR/IN and SEG/F supply (Ordering designation: R-IB IL SCN-PWR IN-CP)
 B2 Black connector for supply terminals of the IndraControl L40 (from connector set R-IB IL CML S01-PLSET)
 C Gray shield connector for analog terminals
 D Large gray connector for peripheral connection

Fig. 9-4: Connector design

Note: Connector B1 must not be used for supplying the IndraControl L40.

Connectors with integrated jumpering of terminal points are shown in Fig. 9-4.

The shield connector is jumpered by the shield connection. All other connectors are jumpered by a connection of the terminal points.

Note: To avoid malfunctions, only latch the connector onto the terminal it is intended for. Refer to the specific data sheet of each module to select the appropriate connector. The black connector may not be latched onto a module that is intended for a double-signal connector. Any reversal would lead to a short-circuit between the two signal terminal points (1.4 - 2.4).

Important: Place only a black B2-type connector (from connector set R-IB IL CML S01-PLSET) on the supply terminal at the IndraControl L40! The terminal point jumpering ensures that the potential is transmitted via the jumpering in the connector and not via the module board.

Connector Coding

It is possible to prevent the mismatching of connectors by coding socket and connector.

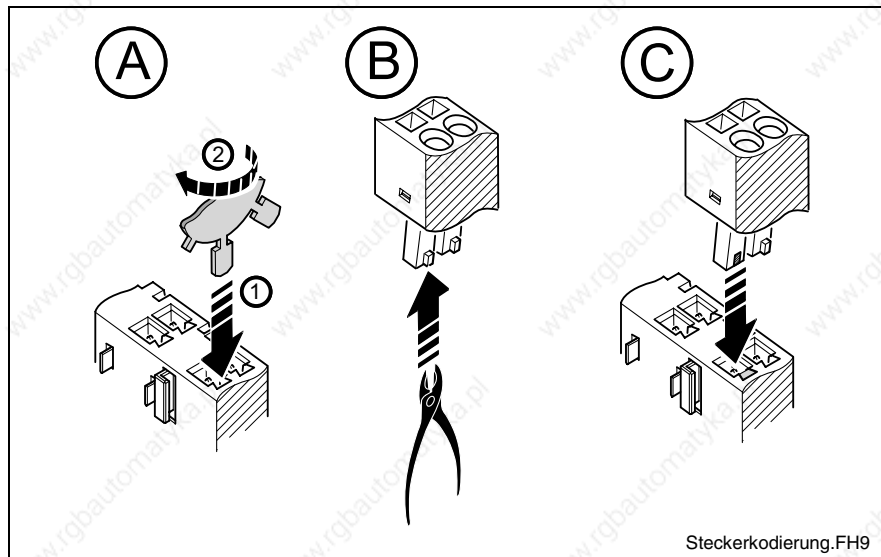

Fig. 9-5: Connector coding

- For this purpose, put a coding profile into the coding keyway in the socket (1) and pull it off the small plate (2) by rotation (Fig. 9-5/A).
- Use a side-cutting pliers to cut the respective coding tab off the connector (Fig. 9-5/B).

Now, only socket and connector of the same coding fit together (Fig. 9-5/C).

9.4 Identification of Function and Labeling

For visual identification of their function, the modules are color-coded (1 in Fig. 9-6).

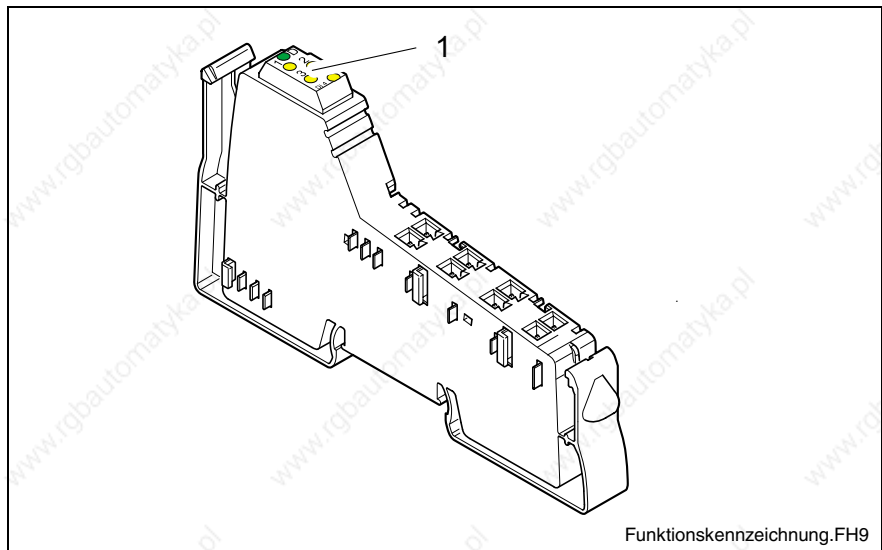

Fig. 9-6: Identification of function

The various functions are identified by the following colors:

Color	Module function
Light-blue	Digital input, 24 V range
Pink	Digital output, 24 V range
Blue	Digital input, 120/230 V range
Red	Digital output, 120/230 V range
Green	Analog input
Yellow	Analog output
Orange	Field bus coupler, function modules *)
Black	Power terminal / segment terminal

Fig. 9-7: Color coding of the modules:

Note: All accepted modules are illustrated in chapter "Accessories" as of page 11-4.

Connector Identification

The color coding of the terminal points is described above (on this page).

Labeling/Numbering of Terminal Points

Numbering of the terminal points is illustrated by means of an 8-slot module.

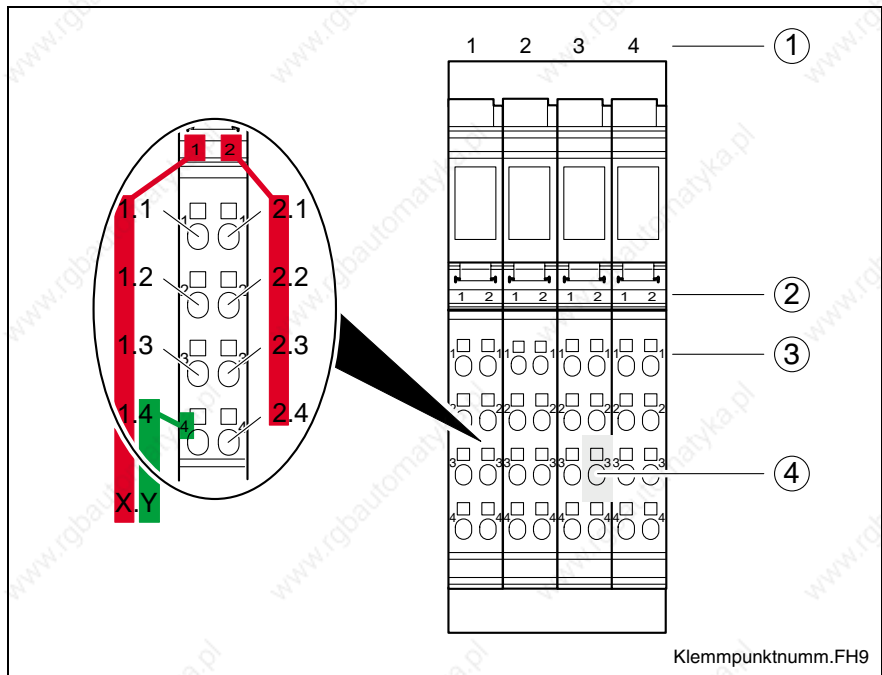

Fig. 9-8: Numbering of terminal points

Slot/Connector

The slots (connectors) on a socket are numbered consecutively (1 in Fig. 9-8). These numbers are **not** specified on the module.

Terminal Point

On each connector, the terminal points are identified by X.Y.

X is the number of the terminal point row on the connector and is indicated on the top of the respective terminal point row (2 in Fig. 9-8).

Y is the number of the terminal point in a row and is indicated directly at the terminal point (3 in Fig. 9-8).

Thus, the position of the slot and terminal point can be exactly determined. For instance, the gray connection (4 in Fig. 9-8) is numbered as follows: slot 3, terminal point 2.3.

Additional Labeling

In addition to the above labeling of the modules, you can label the slots, terminal points and connections with zack marker strips (ZBFMs) and labeling fields.

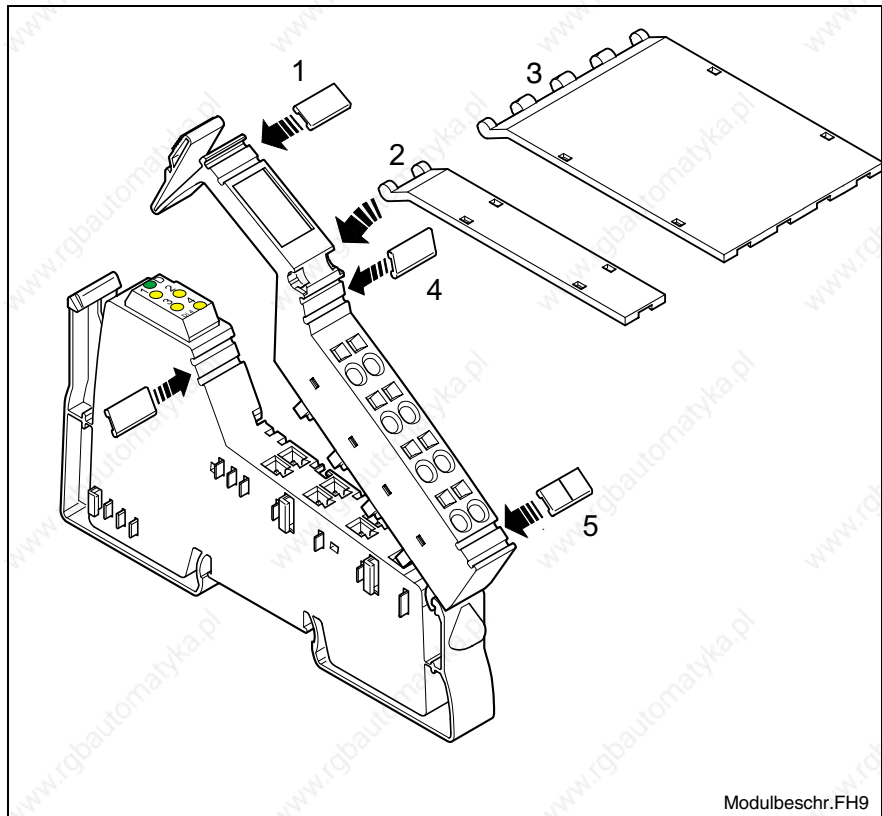

Modulbeschr.FH9

Fig. 9-9: Labeling of modules

There are various possibilities for labeling slots and terminal points:

- 1** You can label each connector individually with zack marker strips.
- 2 / 3** As an option, you can use a large labeling field. This labeling field is available in two widths, either as labeling field covering only one connector (2) or as labeling field covering four connectors (3). Thus, you can label each channel individually with continuous text. In the upper connector head, there is a receptacle to attach the labeling field to the connector(s). The labeling field can be moved up and down. A small catch at both end positions allows the labeling field to keep its position.
- 4 / 5** You can label each signal with zack marker strips. With double-signal connectors, the upper keyway (4) is provided for labeling the signals 1/2, and the bottom keyway (5) for the signals 3/4.
- 6** The electronic socket provides the possibility of labeling each slot individually with zack marker strips. If the connector is latched onto the socket, this labeling is hidden.

You can clearly assign connector and slot by using the labeling field at the connector and on the electronic socket.

9.5 Housing Dimensions of the Modules of the Low Signal Level

Today, small I/O stations are often used in 80 mm standard control boxes. The Rexroth Inline modules have been designed for use in this type of control box.

The housing dimensions of a module are defined by the dimensions of the electronic socket and the connector.

The electronic sockets of the modules of the low signal level are available in three overall widths (12.2 mm; 24.4 mm; and 48.8 mm).

One, two or four connectors of a width of 12.2 mm are fitted on these sockets.

With connector, each module has a depth of 71.5 mm.

The height of the module depends on the connector used. The connectors are available in three versions (see Fig. 9-13).

2-Slot Housing

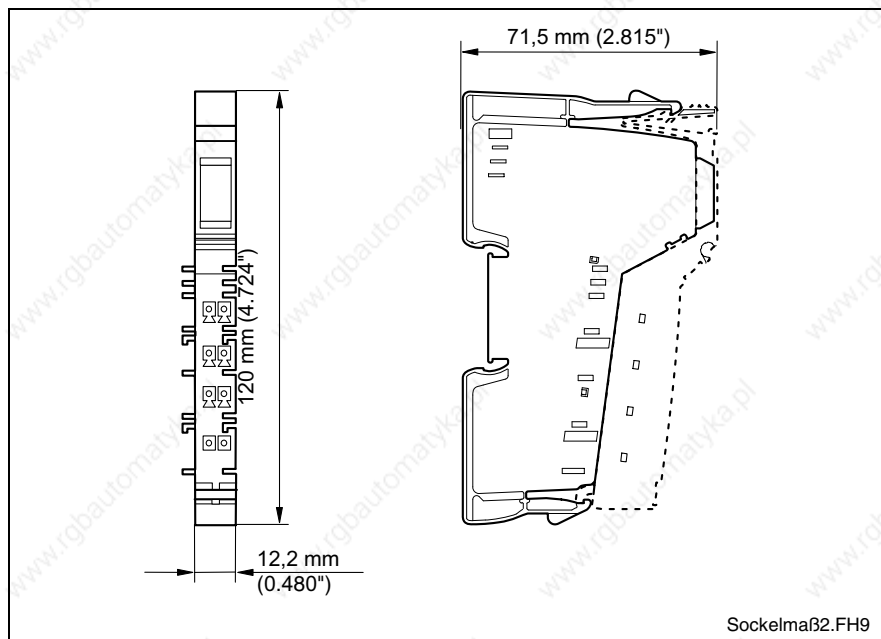

Fig. 9-10: Dimensions of the electronic sockets (2-slot housing)

4-Slot Housing

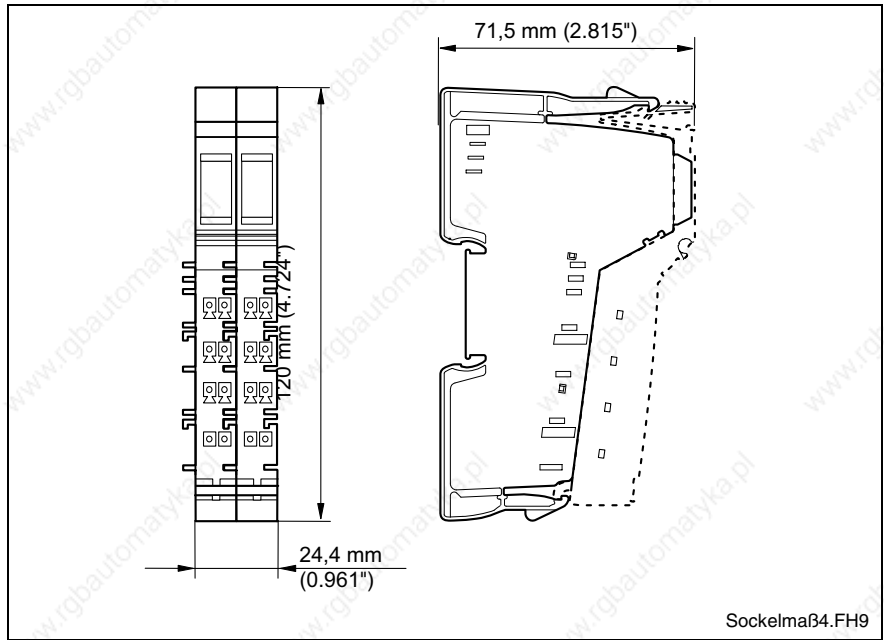

Fig. 9-11: Dimensions of the electronic sockets (4-slot housing)

8-Slot Housing

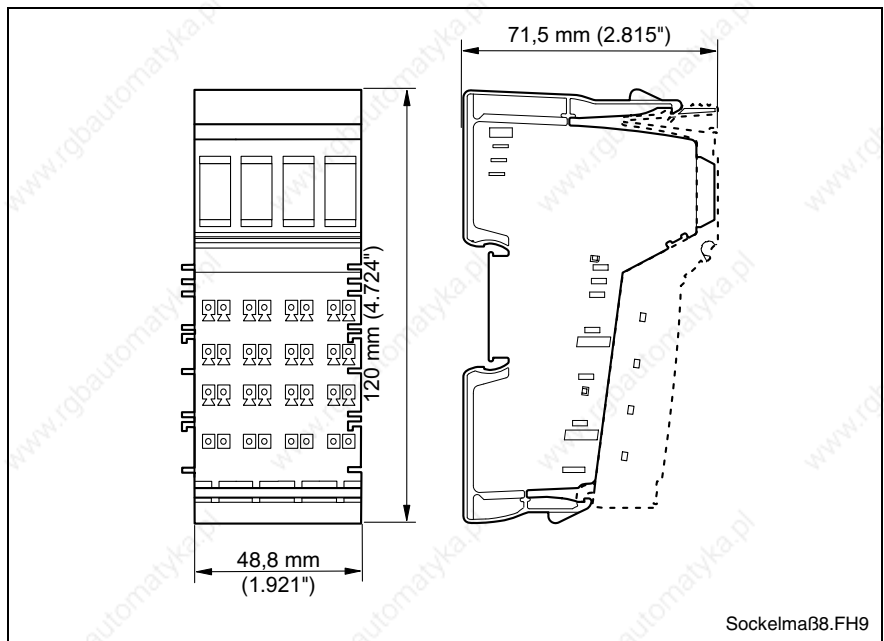
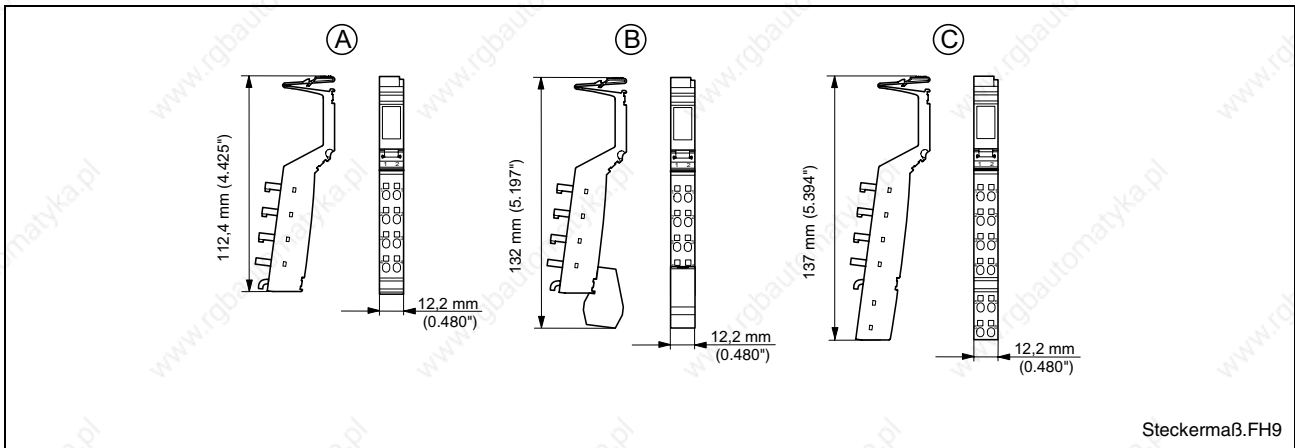

Fig. 9-12: Dimensions of the electronic sockets (8-slot housing)

Connectors



- L: A Standard connector
 B Shield connector
 C Extended double-signal connector

Fig. 9-13: Connector dimensions

The connector depth is irrelevant as it has no effect on the overall module depth.

9.6 Electrical Voltage and Data Routing

An essential feature of the Rexroth Inline product family is the internal voltage routing system. The electrical connection between the individual station devices is established automatically when the station is set up. When the individual station devices are latched to each other, a conductor rail is set up for the respective electric circuit. Mechanically, this contact is realized by the blade and spring contacts of the neighboring modules latching into each other.

Using a special segment circuit, the user does not have to establish the additional external potential transmission to the neighboring modules.

In one station, two independent electric circuits have been realized:

- Logic circuit
- Circuit of peripheral equipment

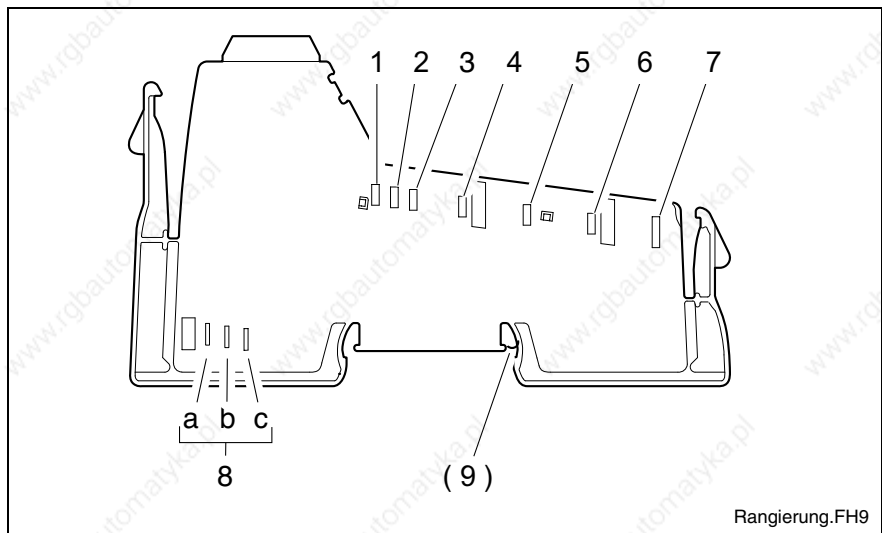

Fig. 9-14: Voltage and data routing

No.	Function	Meaning
1	7.5 V U_L	Supply of module electronics (logic supply)
2	24 V U_{ANA}	Peripheral supply voltage for analog modules
3	GND	Ground of the logic supply voltage and the peripheral supply voltage for analog modules
4	24 V U_S	Supply of the segment circuit (if necessary protected against overload) This voltage jumper does not exist at the 120 V and 230 V voltage levels.
5	24 V U_M	Supply of the main circuit (if necessary protected against overload)
6	GND GND	Ground of the segment and main voltage supply (neutral conductor)
7	FE FE	Functional earth ground
(9)	(FE spring)	FE contact to the top-hat rail (not in all modules)

Fig. 9-15: Voltage jumpers (see Fig. 9-14)

Important: The GND voltage jumper carries the total current of the main and the segment circuit. It may not exceed the maximum current carrying capacity of the voltage jumpers of 8 A. If, during project planning, the limit of 8 A is reached at one of the U_S , U_M and GND voltage jumpers, a new power terminal must be used!

Note: The FE voltage jumper must be connected to a ground terminal at the IndraControl L40 via the terminal point 1.4 or 2.4 (see Fig. 9-8). In addition, it must be connected to the grounded top-hat rail at each supply terminal via the FE spring and routed through all of the modules.

No.	Function	Meaning
8a	DI1	Local bus signal (Data In)
8b	DO1	Local bus signal (Data Out)
8c	DCLK	Clock signal, local bus

Fig. 9-16: Data jumpers (see Fig. 9-14)

9.7 Electric Circuits and Voltage Supply Within a Rexroth Inline Station

There are several electric circuits within a Rexroth Inline station. These circuits are set up automatically, when the modules are latched to each other. The voltages of the different electric circuits are supplied to the connected modules via the voltage jumpers.

Note: Please refer to the functional description for further information about the electric circuit, to which the peripheral circuit of a specific module has to be connected.

Current Carrying Capacity of the Jumper Contacts

The maximum current carrying capacity of the lateral jumper contacts must be observed for each electric circuit. The current carrying capacities for all voltage jumpers are specified in the sections below.



The arrangement of the voltage jumpers is illustrated in the chapter entitled "Voltage and Data Routing" on page 9-11.

The connection of the supply voltages is described in the chapter entitled "Voltage Supply" on page 7-2.

For information on the connection of voltages, please refer to the notes in the module-specific data sheets.

9.8 Diagnostic and Status Indicators

For quick failure diagnostics on site, the IndraControl L40 and all modules are equipped with diagnostic and status LEDs.

Diagnostics The diagnostic indicators (red/green) provide information on the failure type and location. A module operates faultlessly, when all of its green LEDs are lit.

After correction of the failure, the indicators immediately show the current status.

Status The status indicators (yellow) show the state of the pertinent input/output and/or the connected unit.

Note: Please refer to the functional description for information on the diagnostic and status indicators provided on a specific module.

Indicators on the IndraControl L40

The meaning of the light-emitting diodes on the IndraControl L40 have already been described in detail in the related chapters. The sections below comprise a summary.

Interface LEDs To its left, the IndraControl L40 comprises various LEDs particularly indicating the states of the interfaces.

"Stop" LED	Meaning (depending on the firmware)
Off	Normal state
Red	STOP / system fault
Flashing red	Outputs are disabled

Fig. 9-17: Meaning of the "STOP" LED (see chapter "Reset Button and Light-Emitting Diode" on page 6-2)

"Send" LED (optional)	Meaning
LED on	The IndraControl L40 outputs data via PROFIBUS DP.

Fig. 9-18: Meaning of the "Send" LED (see chapter "PROFIBUS DP" on page 7-14)

"Dist." LED (optional)	Meaning
Off	Normal state
Red	The distortion is too high or the receive signal is missing (SERCOS interface).

Fig. 9-19: Meaning of the "Dist." LED Distortion indicator for SERCOS interface (see chapter "SERCOS" on page 7-15)

"Ready" LED (optional)	Meaning
Off	Watchdog not started yet or Ready contact opened via the software (but the watchdog is still triggered internally).
Green	Ready contact closed; watchdogs still triggered.
Red	Ready error; at least one watchdog has responded.

Fig. 9-20: Meaning of the "Ready" LED (see chapter "Ready contact" on page 7-15)

Voltage Supply LEDs

The following LEDs are arranged at the terminal strip for voltage supply:

"UM" LED	Meaning
Off	Main circuit supply is missing.
Green	24 V supply U_M of main circuit is present.

Fig. 9-21: Diagnostic LED of the power terminal

"US" LED	Meaning
Off	Segment circuit supply is missing.
Green	24 V supply U_S of segment circuit is present.

Fig. 9-22: Diagnostic LED of the segment terminal

"UL" LED	Meaning
Off	Supply voltage U_{LS} is missing.
Green	24 V supply voltage U_{LS} is present.

Fig. 9-23: Diagnostic LED of the supply voltage

"FS" and "FN" LEDs	Meaning
	No function at present.

Fig. 9-24: "FS" and "FN" LEDs

LEDs at the Onboard I/Os

An LED is assigned to each input and each output of the digital onboard I/Os, indicating the particular state of these inputs and outputs.

LEDs 1, 2, 3, 4	Meaning
Off	The assigned input/output is not set.
Yellow	The assigned input/output is set.

Fig. 9-33: Status LEDs of input/output terminals

Moreover, there is a light-emitting diode that is identified by D.

Light-emitting diode D	Meaning
Off	24 V voltage is missing.
Green	24 V voltage is present.
Red	Short-circuit or overload.

Fig. 9-25: Light-emitting diode D (see chapters "Digital Onboard Inputs" and "Digital Outputs" on page 7-9 and following pages)

Indicators on the Supply Terminals

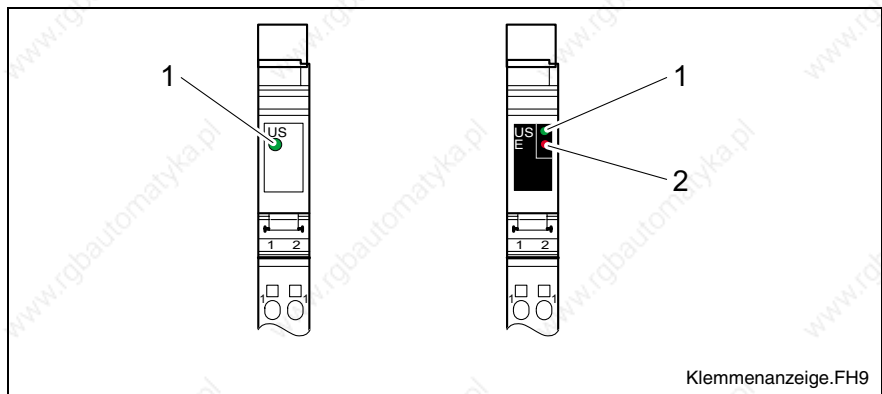

Fig. 9-26: Possible indicators on supply terminals (here: segment terminal without and with fuse)

Diagnostics

The following states are indicated by the supply terminals:

LED	Color	Status	Description of LED states
UM (1)	Green	On	24 V supply of the main circuit is present.
		Off	Main circuit supply is not present.

Fig. 9-28: Diagnostic LED of the power terminal

LED	Color	Status	Description of LED states
US (1)	Green	On	24 V supply of the segment circuit is present.
		Off	Segment circuit supply is not present.

Fig. 9-29: Diagnostic LED of the segment terminal

LED	Color	Status	Description of LED states
E (2)	Red	On	No fuse, or tripped fuse
		Off	Fuse okay

Fig. 9-30: Additional LED for supply terminals with fuse

Note:

In modules with fuse, the green LED indicates that the main or segment voltage is available **upstream** of the fuse. That means that, with the green LED being lit, the voltage is applied upstream of the fuse. If the red LED is lit as well, the voltage is not applied to the output side! Either there is no fuse, or the fuse is defective.

Indicators on the Input/Output Modules

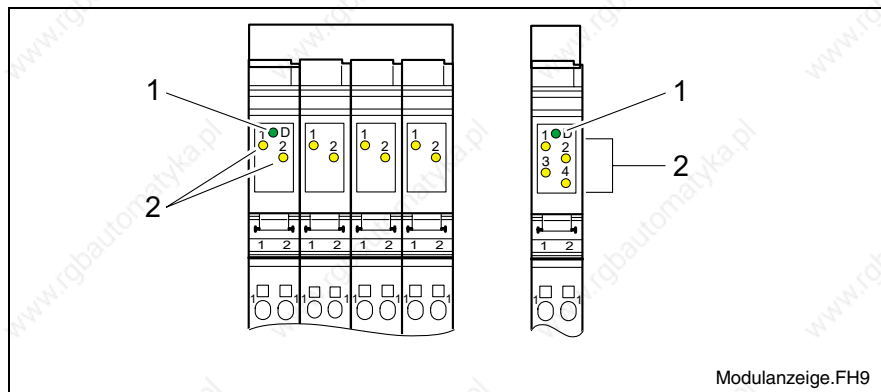

Fig. 9-27: Indicators on the input/output modules

Diagnostics The following states are indicated by the input/output modules:

LED	Color	Status	Description of LED states
D (1)	Green	On	Local bus active
		Flashing: 0.5 Hz (slow)	Logic voltage available, local bus not active
		2 Hz (medium)	Logic voltage available, local bus active, periphery error pending
		4 Hz (fast)	Logic voltage available; module upstream of the flashing module failed; or module itself is defective. Modules downstream of the flashing module are not included in the configuration scope.
		Off	Logic voltage not available, local bus not active

Fig. 9-28: Diagnostic LED of input/output modules

Status The status of the input or output is indicated by the corresponding yellow LED.

LED	Color	Status	Description of LED states
1, 2, 3, 4 (2)	Yellow	On	The assigned input/output is set.
		Off	The assigned input/output is not set.

Fig. 9-33: Status LEDs of input/output terminals

Assignment of status LED to input/output

Please refer to the functional description for information on the assignment of a status LED to the corresponding input/output.

Indicators on Other Inline Modules

Please refer to the functional description for information on the diagnostic and status indicators on other Inline modules (e. g. functional modules or power modules).

10 Disposal and Environmental Protection

10.1 Disposal

Products

Our products can be returned to us free of charge for disposal. However, it is a precondition that the products are free of oil, grease or other dirt.

Furthermore, the products returned for disposal must not contain any undue foreign matter or foreign component.

Please send the products free domicile to the following address:

Bosch Rexroth AG
Electric Drives and Controls
Bürgermeister-Dr.-Nebel-Straße 2
D-97816 Lohr am Main

Packaging Materials

The packaging materials consist of cardboard, wood and polystyrene. These materials can be easily recycled. For ecological reasons, please refrain from returning the empty packages to us.

10.2 Environmental Protection

No Release of Hazardous Substances

Our products do not contain any hazardous substances, which may be released in the case of appropriate use. Accordingly, our products will normally not have any negative effect on the environment.

Materials Contained in the Products

Electronic Devices

Electronic devices mainly contain:

- steel
- aluminum
- copper
- synthetic materials
- electronic components and modules

Motors

Motors mainly contain:

- steel
- aluminum
- copper
- brass
- magnetic materials
- electronic components and modules

Recycling

Due to their high content of metal most of the product components can be recycled. In order to recycle the metal in the best possible way, the products must be disassembled into individual modules.

Metals contained in electric and electronic modules can also be recycled by means of special separation processes. The synthetic materials remaining after these processes can be thermally recycled.

If the products contain batteries or rechargeable batteries, these batteries are to be removed and disposed before they are recycled.

Function Modules

Abbrev. Column	1	2	3	4	5	6	7	8	9	0	1	2	3	4	5	6	7	8	9	0	2	1	2	3	4	5	6	7	8	9	0	3	1	2	3	4	5	6	7	8	9	0	4	1	2	3	4	5	6	7	8	9	0	
Example:	C	F	L	0	1	.	1	-	P	1																																												

- 1. Product**
 - 1.1 Assembly group = CF
- 2. Housing design**
 - 2.1 Inline. = L
- 3. Line**
 - 3.1 1 = 01
- 4. Design**
 - 4.1 1 = 1
- 5. Interface**
 - 5.1 without = NN
 - 5.2 INTERBUS master = B1
 - 5.3 INTERBUS slave = B2
 - 5.4 Fast I/O (In-/Output modules with 8xI / 8xO and 8xI/O configurable) = E2
 - 5.5 LAG: 2 encoder EnDat. = G2
 - 5.6 LAG: 1 encoder EnDat and sensor probe = G3
 - 5.7 CanOpen master = K1
 - 5.8 CanOpen slave = K2
 - 5.9 ASi master module = M1
 - 5.10 PLS module = N1
 - 5.11 PROFIBUS-DP Master = P1
 - 5.12 PROFIBUS-DP Slave = P2
 - 5.13 Cross communication = Q2
 - 5.14 Sercos 3. = R3
 - 5.15 RT-Ethernet master, configurable (PROFINET IO, EtherNet/IP, TCP/IP) = T1
 - 5.16 DeviceNet master = V1
 - 5.17 DeviceNet slave. = V2
 - 5.18 Memory, 8MB. = Y1

Typenschlüssel-FM.EPS

Fig. 11-3: Type code of the function modules

11.2 Accessories

Necessary Accessories (Connector Set)

The following connector set is required for connecting the IndraControl L40:

Ordering designation	Part number	Description
R-IB IL CML S01-PLSET	R911299856	Connector set for IndraControl L40

Additional Accessories (Blower, Function Modules, Inline Modules and Interface Cables)

Blower

Ordering designation	Part number	Description
CAL01.1-F1	R911306144	Blower

Rexroth Function Modules

Ordering designation	Part number	Description
CFL01.1-Y1	R911170007	SRAM
CFL01.1-V1	R911170001	DeviceNet master
CFL01.1-P1	R911170005	Profibus master
CFL01.1-R3	R911170008	Sercos III
CFL01.1-Q2	R911170009	Cross communication
CFL01.1-E2	R911170365	Cam switch
CFL01.1-N1	R911170012	Fast I/O

Rexroth Inline Modules

Ordering designation	Part number	Description
<u>Digital input terminals:</u>		
R-IB IL 24 DI 2	R911289286	2 inputs, 24 V DC, 4-wire connection, width: 12.2 mm
R-IB IL 24 EDI 2-DES	R911289292	2 Desina diagnostic inputs, overall width: 12.2 mm
R-IB IL 24 DI 4	R911289287	4 inputs, 24 V DC, 3-wire connection, width: 12.2 mm
R-IB IL 24 DI 8	R911289288	8 inputs, 24 V DC, 4-wire connection, width: 48.8 mm
R-IB IL 24 DI 16	R911289290	16 inputs, 24 V DC, 3-wire connection, width: 48.8 mm
R-IB IL 24 DI 32/HD	R911297188	32 inputs, 24 V DC, 1-wire connection, width: 48.8 mm

<u>Digital output terminals:</u>		
R-IB IL 24/230 DOR1/W	R911289301	1 relay change-over contact, 5-253 V AC, 3 A, gold plated, to switch lamp loads, width: 12.2 mm
R-IB IL 24 DO 2-2A	R911289294	2 outputs, 24 V DC, 2 A, 4-wire connection, width: 12.2 mm
R-IB IL 24 DO 4	R911289295	4 outputs, 24 V DC, 500 mA, 3-wire connection, overall width: 48.8 mm
R-IB IL 24/230 DOR4/W	R911289302	4 relay change-over contacts, 5-253 V AC, 3 A, gold plated, overall width: 48.8 mm
R-IB IL 24 DO 8	R911289297	8 outputs, 24 V DC, 500 mA, 4-wire connection, overall width: 48.8 mm
R-IB IL 24 DO 8-2A	R911289298	8 outputs, 24 V DC, 2 A, 4-wire connection, overall width: 48.8 mm
R-IB IL 24 DO 16	R911289299	16 outputs, 24 V DC, 500 mA, 3-wire connection, overall width: 48.8 mm
R-IB IL 24 DO 32/HD	R911297191	32 outputs, 24 V DC, 1 A, 1-wire connection, overall width: 48.8 mm
R-IB IL DOR LV-SET	R911291260	Spacing terminals to use the relay output terminals, overall width: 12.2 mm each
<u>Analog input terminals:</u>		
R-IB IL AI 2/SF	R911289306	2 inputs, 0-20 mA, 4-20 mA, ± 20 mA, 0-10 V, ± 10 V, overall width: 12.2 mm
R-IB IL TEMP 2 RTD	R911289305	2 inputs for resistance detectors, overall width: 12.2 mm
<u>Analog output terminals:</u>		
R-IB IL AO 1/SF	R911289303	1 output, 0-20 mA, 4-20 mA, 0-10 V, overall width: 24.4 mm
R-IB IL AO 2/U/BP	R911289381	2 outputs, 0-10 V, ± 10 V, overall width: 12.2 mm
R-IB IL CNT	R911289315	Counter terminal
<u>Connectors:</u>		
R-IB IL AO/CNT-PLSET	R911289339	Connector set for analog output modules and counter terminal
R-IB IL DOR LV-PLSET	R911291261	Connector set for voltage spacing terminals 230V/24V
R-IB IL SCN-6 SHIELD	R911289331	6-pin connector with shield connector for a cable
R-IB IL SCN-6 SHIELD-TWIN	R911289332	6-pin connector with shield connector for two cables
R-IB IL SCN-8	R911291191	8-pin connector
R-IB IL SCN-8-AC-REL	R911289337	8-pin connector for relay terminals
R-IB IL SCN-8-CP	R911289323	8-pin connector, color-coded
R-IB IL SCN-12-ICP	R911289326	12-pin connector for inputs, color-coded
R-IB IL SCN-12-OCP	R911289327	12-pin connector for outputs, color-coded
R-IB IL SCN-PWR IN-CP	R911289328	Connector for power terminal, color-coded
<u>Labeling field:</u>		
R-IB IL FIELD 2	R911289341	Labeling fields: 12.2 mm
R-IB IL FIELD 8	R911289342	Labeling fields: 48.8 mm

Interface Cable

Ordering designation	Part number	Description
<u>Serial interface:</u>		
RKB0009/005,0	R911170155	RS232 cable, 9-pin DSUB on both sides, 5 m
<u>Ethernet interface:</u>		
RKB0007/00,15	R911170146	Ethernet cable, 10-Base-T, CAT.5, crosslink, ready-made, with RJ45 connector on both sides, 0.15 m
RKB0007/002,5	R911170147	Ethernet cable, 10-Base-T, CAT.5, crosslink, ready-made, with RJ45 connector on both sides, 2.5 m
RKB0007/005,0	R911170148	Ethernet cable, 10-Base-T, CAT.5, crosslink, ready-made, with RJ45 connector on both sides, 5.0 m
RKB0007/010,0	R911170149	Ethernet cable, 10-Base-T, CAT.5, crosslink, ready-made, with RJ45 connector on both sides, 10.0 m
RKB0007/025,0	R911170150	Ethernet cable, 10-Base-T, CAT.5, crosslink, ready-made, with RJ45 connector on both sides, 25.0 m
RKB0008/002,5	R911170151	Ethernet cable, 10-Base-T, CAT.5, ready-made, on both sides with RJ45 connector, 2.5 m
RKB0008/005,0	R911170152	Ethernet cable, 10-Base-T, CAT.5, ready-made, on both sides with RJ45 connector, 5.0 m
RKB0008/010,0	R911170153	Ethernet cable, 10-Base-T, CAT.5, ready-made, on both sides with RJ45 connector, 10.0 m
RKB0008/025,0	R911170154	Ethernet cable, 10-Base-T, CAT.5, ready-made, on both sides with RJ45 connector, 25.0 m
<u>Profibus DP:</u>		
REB0001	R911170134	Profibus cable, Fast Connect, standard
REB0002	R911170136	Profibus cable, Fast Connect, cable carrier, tensile force 100 N
REB0003	R911170135	Profibus cable, cable carrier, tensile force 20 N
RBS0010/K02	R911170137	Profibus connector 12 Mbauds
RBS0011/K02	R911170138	Profibus connector 12 Mbauds, with PG female connector
RBS0012/K02	R911170139	Profibus connector 12 Mbauds, 180° offset
RBS0013/F03	R911170140	Profibus connector 12 Mbauds, 90° offset, Fast Connect
RBS0014/F03	R911170141	Profibus connector 12 Mbauds, 90° offset, Fast Connect, with PG female connector
RBS0015/F03	R911170142	Profibus connector 12 Mbauds, 180° offset, Fast Connect
WERKZ-ABISOLIERER-FC-KABEL	R911170143	Stripping tool for PROFIBUS Fast Connect cable
WERKZ-ABISOLIERER-FC-KABEL	R911170144	Spare knife for stripping tool (packaging seize: 5 pieces)

SERCOS lines (FO):		
RKO0100/00,15 (ROS0001-INK0414-ROS0001)	R911308249	FO cable, diameter: 2.2 mm, length: 0.15 m
RKO0100/00,25 (ROS0001-INK0414-ROS0001)	R911308248	FO cable, diameter: 2.2 mm, length: 0.25 m
RKO0100/00,30 (ROS0001-INK0414-ROS0001)	R911308247	FO cable, diameter: 2.2 mm, length: 0.3 m
RKO0100/00,50 (ROS0001-INK0414-ROS0001)	R911308246	FO cable, diameter: 2.2 mm, length: 0.5 m
RKO0100/01,00 (ROS0001-INK0414-ROS0001)	R911308240	FO cable, diameter: 2.2 mm, length: 1.0 m
RKO0101/05,00 (ROS0002-INK0435-ROS0002 5m)	R911308242	FO cable, diameter: 6.0 mm, length: 5 m
RKO0101/10,00 (ROS0002-INK0435-ROS0002 10m)	R911308243	FO cable, diameter: 6.0 mm, length: 10 m
RKO0101/15,00 (ROS0002-INK0435-ROS0002 15m)	R911308244	FO cable, diameter: 6.0 mm, length: 15 m
RKO0101/20,00 (ROS0002-INK0435-ROS0002 20m)	R911308245	FO cable, diameter: 6.0 mm, length: 20 m
INK0414	R911238491	FO cable, diameter: 2.2 mm (sold by the meter)
INK0435	R911257322	FO cable, diameter: 6.0 mm (sold by the meter)

Fig. 11-4: Interface cables

Notes

12 List of Figures

- Fig. 1-1: Front view of an IndraControl L40 1-1
- Fig. 1-2: Related documentations 1-2
- Fig. 3-1: Hazard classification (according to ANSI Z535) 3-1
- Fig. 4-1: Equipment 4-1
- Fig. 4-2: Current consumption 4-1
- Fig. 4-3: Ambient conditions 4-2
- Fig. 4-4: Used standards 4-3
- Fig. 5-1: Bottom view 5-1
- Fig. 5-2: Front view 5-1
- Fig. 5-3: Lateral view from the left (the cutout for the top-hat rail is arranged centrally) 5-2
- Fig. 6-1: Display with four operating keys 6-1
- Fig. 6-2: Reset button and stop LED 6-2
- Fig. 7-1: IndraControl L40 connections 7-1
- Fig. 7-2: Supply voltage connections 7-2
- Fig. 7-3: Pin assignment of the voltage module 7-3
- Fig. 7-4: Diagnostic LED of the power terminal 7-3
- Fig. 7-5: Diagnostic LED of the segment terminal 7-3
- Fig. 7-6: Diagnostic LED of the supply voltage 7-3
- Fig. 7-7: "FS" and "FN" LEDs 7-3
- Fig. 7-8: Main circuit 7-4
- Fig. 7-9: Segment circuit 7-5
- Fig. 7-10: Address assignment of inputs and outputs 7-7
- Fig. 7-11: Digital inputs 7-8
- Fig. 7-12: Data of digital inputs 7-9
- Fig. 7-13: Status LEDs of digital inputs 7-9
- Fig. 7-14: Light-emitting diode D 7-9
- Fig. 7-15: Digital outputs 7-9
- Fig. 7-16: Data of digital outputs 7-10
- Fig. 7-17: Status LEDs of digital outputs 7-11
- Fig. 7-18: Light-emitting diode D 7-11
- Fig. 7-19: RS232 interface 7-12
- Fig. 7-20: Ethernet interface 7-13
- Fig. 7-21: Parameters for PROFIBUS DP line 7-14
- Fig. 7-22: Maximum segment length in relation to the transmission rate 7-14
- Fig. 7-23: "Send" light-emitting diode 7-15
- Fig. 7-24: Distortion indicator 7-15
- Fig. 7-25: Characteristic data of the ready contact 7-15
- Fig. 7-26: Ready LED 7-16
- Fig. 7-27: Current and power supply 7-17
- Fig. 7-28: Ambient conditions 7-18

- Fig. 7-29: SRAM function module 7-19
- Fig. 7-30: Insert new battery 7-20
- Fig. 7-31: DeviceNet master module 7-21
- Fig. 7-32: Pin assignment of the X7D connector 7-22
- Fig. 7-33: Meaning of the light emitting diodes at the DeviceNet master function module 7-22
- Fig. 7-34: Profibus DP master function module 7-23
- Fig. 7-35: Pin assignment of the X7D connector 7-24
- Fig. 7-36: Meaning of the light-emitting diodes at the DP master function module 7-24
- Fig. 7-37: SERCOS III module 7-25
- Fig. 7-38: Pin assignment of the X7S1, X7S2 connector 7-25
- Fig. 7-39: Cross communication function module 7-26
- Fig. 7-40: Fast I/O function module 7-27
- Fig. 7-41: Input and output connectors X2I1, X2D2 and X2O1 7-28
- Fig. 7-42: Feeder connector X1S 7-28
- Fig. 7-43: States of the status LED 7-28
- Fig. 7-44: Wiring the module 7-29
- Fig. 7-45: Data of digital inputs 7-30
- Fig. 7-46: Data of digital outputs 7-31
- Fig. 7-47: Peripheral voltage according to DIN EN 61131-2 7-32
- Fig. 7-48: Cam switch function module 7-33
- Fig. 7-49: Output connectors X2O1 and X2O2 7-34
- Fig. 7-50: Feeder connector X1S 7-34
- Fig. 7-51: States of the status LED 7-34
- Fig. 7-52: Wiring the module 7-35
- Fig. 7-53: Data of digital outputs 7-36
- Fig. 7-54: Peripheral voltage according to DIN EN 61131-2 7-37
- Fig. 8-1: Module slot and slot number of function modules 8-2
- Fig. 8-2: Fitting and removing a function module 8-2
- Fig. 8-3: Before dismounting the IndraControl L40, the first Rexroth Inline module must be removed. 8-4
- Fig. 8-4: Latching on a module 8-6
- Fig. 8-5: Removing a module 8-7
- Fig. 8-6: Fuse replacement 8-8
- Fig. 8-7: Setup without electrical isolation 8-10
- Fig. 8-8: Setup with electrical isolation 8-11
- Fig. 8-9: Reference conductor connected to the protective conductor 8-12
- Fig. 8-10: Reference conductor not connected to the protective conductor 8-13
- Fig. 8-11: Overview: Shield connection of analog sensors and actuators 8-16
- Fig. 8-12: Connection of analog sensors in case of signal lines > 10 m 8-16
- Fig. 8-13: Connection of actuators, in case of signal lines > 10 m 8-17
- Fig. 8-14: Connecting lines to the tension spring connectors 8-18

- Fig. 8-15: Connecting the shield to the shield connector 8-19
- Fig. 8-16: Orientation of the shield clip 8-20
- Fig. 9-1: Basic structure of a Rexroth Inline modules 9-1
- Fig. 9-2: Rexroth Inline connector types 9-2
- Fig. 9-3: Color-coding of the terminal points 9-3
- Fig. 9-4: Connector design 9-3
- Fig. 9-5: Connector coding 9-4
- Fig. 9-6: Identification of function 9-5
- Fig. 9-7: Color coding of the modules: 9-5
- Fig. 9-8: Numbering of terminal points 9-6
- Fig. 9-9: Labeling of modules 9-7
- Fig. 9-10: Dimensions of the electronic sockets (2-slot housing) 9-8
- Fig. 9-11: Dimensions of the electronic sockets (4-slot housing) 9-9
- Fig. 9-12: Dimensions of the electronic sockets (8-slot housing) 9-9
- Fig. 9-13: Connector dimensions 9-10
- Fig. 9-14: Voltage and data routing 9-11
- Fig. 9-15: Voltage jumpers (see Fig. 9-14) 9-11
- Fig. 9-16: Data jumpers (see Fig. 9-14) 9-12
- Fig. 9-17: Meaning of the "STOP" LED (see chapter "Reset Button and Light-Emitting Diode" on page 6-2) 9-13
- Fig. 9-18: Meaning of the "Send" LED (see chapter "PROFIBUS DP" on page 7-14) 9-13
- Fig. 9-19: Meaning of the "Dist." LED Distortion indicator for SERCOS interface (see chapter "SERCOS" on page 7-15) 9-13
- Fig. 9-20: Meaning of the "Ready" LED (see chapter "Ready contact" on page 7-15) 9-14
- Fig. 9-21: Diagnostic LED of the power terminal 9-14
- Fig. 9-22: Diagnostic LED of the segment terminal 9-14
- Fig. 9-23: Diagnostic LED of the supply voltage 9-14
- Fig. 9-24: "FS" and "FN" LEDs 9-14
- Fig. 9-25: Light-emitting diode D (see chapters "Digital Onboard Inputs" and "Digital Outputs" on page 7-9 and following pages) 9-14
- Fig. 9-26: Possible indicators on supply terminals (here: segment terminal without and with fuse) 9-15
- Fig. 9-27: Indicators on the input/output modules 9-16
- Fig. 9-28: Diagnostic LED of input/output modules 9-16
- Fig. 11-1: Type code of the IndraControl L40.1 11-1
- Fig. 11-2: Type code of the IndraControl L40.2 11-2
- Fig. 11-3: Type code of the function modules 11-3
- Fig. 11-4: Interface cables 11-7

13 Index

2

2-slot housing 9-8

4

4-slot housing 9-9

8

8-slot housing 9-9

A

Accessories 11-4

Actuators 8-17

Addresses

 Digital inputs and outputs 7-7

Air pressure 4-2, 7-18

Ambient conditions 4-2

Analog input module IB IL 24 AI 2/SF 8-16

Analog output module IB IL AO ... 8-17

Analog sensors 8-16

Appropriate use

 Introduction 2-1

 Uses 2-2

B

Blower 4-3

Bus signal connection 8-5

C

CFL01.1-E2 Fast I/O function module 7-27

CFL01.1-N1 Cam switch function module 7-33

CFL01.1-P1 Profibus DP master function module 7-23

CFL01.1-Q2 Cross Communication Function Module 7-26

CFL01.1-R3 SERCOS III function module 7-25

CFL01.1-V1 DeviceNet master function module 7-21

CFL01.1-Y1 SRAM function module 7-19

Compact Flash 7-16

Compatibility test 4-4

Connections 7-1

 Overview 7-1

Connector Identification 9-5

Connector shaft latch 8-5

D

Data routing 9-11

Diagnostic indicators 9-13

Digital inputs 7-8

 Addresses 7-7

Digital outputs

 Addresses 7-7

Dimensions 5-1

 Bottom view 5-1

 Front view 5-1

 Lateral view 5-2

Display 6-1

Display and operating components 6-1

Disposal 10-1

Double-signal connector 9-10

E

Electric installation 8-9
Electrical isolation 8-11
Electronic socket 9-1
 Dimensions of 2-slot housing 9-8
 Dimensions of 4-slot housing 9-9
 Dimensions of 8-slot housing 9-9
 Overall widths 9-1
End plate 8-1
Environmental Protection 10-1
Ethernet connection 7-13

F

FE spring 9-12
FE voltage jumper 8-15
Function modules 7-17
Function modules, cam switch 7-33
Function modules, Cross-Communication 7-26
Function modules, DeviceNet master 7-21
Function modules, Fast I/O 7-27
Function modules, Profibus DP master 7-23
Function modules, SERCOS III 7-25
Function modules, SRAM 7-19
Functional earth ground 8-15
Fuse 8-14

G

Generation of U_M 7-4
Generation of U_S 7-5
Ground connection 8-15
Ground loops 8-17
Ground terminal 9-12

I

I/O stations 9-8
Inappropriate use 2-2
 Consequences, Discharge of liability 2-1
Inline modules
 2-slot housing 9-8
 4-slot housing 9-9
 8-slot housing 9-9
 Analog terminals 9-3
 Basic structure 9-1
 Color coding 9-5
 Connector coding 9-4
 Connector design 9-3
 Connector identification 9-2, 9-5
 Connector types 9-2
 Connector width 9-2
 Connectors 9-2, 9-10
 Data jumper 9-12
 Diagnostic and status indicators 9-13
 Diagnostic indicators 9-13
 Dismounting 8-6
 Double-signal connector 9-3, 9-10
 Electric circuits 9-12
 Electronic socket 9-1
 End clamp / CLIPFIX 8-3
 Ground terminal 9-12
 Housing dimensions 9-8
 Identification of function 9-5
 Identification of function and labeling 9-5
 Indicators on other Inline modules 9-16
 Jumper contacts 9-12
 Jumpering 9-3
 Labeling of modules 9-7

- Latching on a module 8-6
- Mounting 8-5
- Mounting rail 8-1
- Numbering of terminal points 9-6
- Removing a module 8-7
- Replacing a module 8-7
- Shield connector 9-2, 9-10
- Slot 9-6
- Standard connector 9-2, 9-10
- Status indicators 9-13
- Structure 9-1
- Supply voltages 9-12
- Terminal point 9-6
- Terminal points 9-3
- Top-hat rail 8-1, 8-5
- Voltage and data routing 9-11
- Inline station
 - Connection of actuators 8-17
 - Connection of analog sensors 8-16
 - Orientation of the shield clip 8-20
- Input module IB IL 24 AI 2/SF 8-16
- Input/output modules
 - Diagnostics 9-16
 - Status 9-16
- Installation
 - Electric 8-9
 - Mechanical 8-1
- Interfaces 7-1, 7-12
 - Digital inputs 7-8
 - Ethernet 7-13
 - Overview 7-1
 - PROFIBUS DP 7-14
 - RS232 7-12
 - SERCOS 7-15

J

- Jumper contacts
 - Current carrying capacity 9-12

K

- Keys 6-1
- Keyway/feather key connection 8-5

L

- Low signal level 9-1, 9-8
 - Housing dimensions 9-8
 - Housing dimensions of a module 9-8

M

- Main circuit 7-4
- Main switch 8-14
- Maintenance 8-20
- Materials 10-1
- Max. shock 4-2, 7-18
- Max. vibration 4-2, 7-18
- Maximum surrounding air temperature 4-2, 7-18
- Mechanical installation 8-1
- Memory card 7-16
- Modules of the low signal level 9-1
- Mounting 8-1

N

- Numbering of terminal points 9-6

O

Operating components 6-1
Operating Keys 6-1
Ordering information 11-1
Output module IB IL AO... 8-17

P

Peripheral circuit 9-12
Potential equalization 8-15
Potential transmission 9-11
Power consumption 4-2
Power supply unit 8-9
PROFIBUS DP connection 7-14
PROFIBUS line
Shielding 8-15

R

Ready contact 7-15
Recycling 10-2
Relative humidity 4-2, 7-18
Reset Button 6-2
RS232 connection 7-12

S

Safety Instructions for Electric Drives and Controls 3-1
Segment circuit 7-5, 9-11
Segment voltage 7-5
SERCOS connection 7-15
Shield clip 8-20
Shield connector 8-16, 8-17, 8-19, 9-10
Shielded lines 8-16, 8-17, 8-19
Shielding 8-15
Shielding the PROFIBUS line 8-15
Standard connector 9-10
Status indicators 9-13
Stop LED 6-2
Supply terminals
Diagnostics 9-15
Indicators 9-15
System presentation 1-1
Brief description 1-1
View 1-1

T

Technical data 4-1
Ambient conditions 4-2
Equipment 4-1
Power supply 4-1
Used standards 4-3
Temperature 4-3
Type code 11-1

U

UL/CSA certification 4-4
 U_M 7-4
Use *See appropriate use and inappropriate use*

V

Voltage routing 9-11
Voltage supply 7-2
24 V 8-10
Dimensioning 8-14

Z

Zack marker strip 9-7
Zack marker strips 9-1

14 Service & Support

14.1 Helpdesk

Unser Kundendienst-Helpdesk im Hauptwerk Lohr am Main steht Ihnen mit Rat und Tat zur Seite. Sie erreichen uns

Our service helpdesk at our headquarters in Lohr am Main, Germany can assist you in all kinds of inquiries. Contact us

- telefonisch - by phone: **+49 (0) 9352 40 50 60**
über Service Call Entry Center Mo-Fr 07:00-18:00 Central European Time
- via Service Call Entry Center Mo-Fr 7:00 am - 6:00 pm CET
- per Fax - by fax: **+49 (0) 9352 40 49 41**
- per e-Mail - by e-mail: service.svc@boschrexroth.de

14.2 Service-Hotline

Außerhalb der Helpdesk-Zeiten ist der Service Deutschland direkt ansprechbar unter

After helpdesk hours, contact the German service experts directly at

+49 (0) 171 333 88 26

oder - or

+49 (0) 172 660 04 06

Hotline-Rufnummern anderer Länder entnehmen Sie bitte den Adressen in den jeweiligen Regionen.

Hotline numbers of other countries to be seen in the addresses of each region.

14.3 Internet

Unter www.boschrexroth.com finden Sie ergänzende Hinweise zu Service, Reparatur und Training sowie die **aktuellen** Adressen *) unserer auf den folgenden Seiten aufgeführten Vertriebs- und Servicebüros.

At www.boschrexroth.com you can find additional notes about service, repairs and training. The current addresses *) for our sales and service facilities locations around the world are on the following pages.



Verkaufsniederlassungen



Niederlassungen mit Kundendienst



sales agencies



sales agencies providing service

Außerhalb Deutschlands nehmen Sie bitte zuerst Kontakt mit unserem für Sie nächstgelegenen Ansprechpartner auf.

Please contact our sales / service office in your area first.

*) Die Angaben in der vorliegenden Dokumentation können seit Drucklegung überholt sein.

*) Data in the present documentation may have become obsolete since printing.

14.4 Vor der Kontaktaufnahme... - Before contacting us...

Wir können Ihnen schnell und effizient helfen wenn Sie folgende Informationen bereithalten:

For quick and efficient help, please have the following information ready:

1. detaillierte Beschreibung der Störung und der Umstände.
2. Angaben auf dem Typenschild der betreffenden Produkte, insbesondere Typenschlüssel und Seriennummern.
3. Tel./Faxnummern und e-Mail-Adresse, unter denen Sie für Rückfragen zu erreichen sind.

1. Detailed description of the failure and circumstances.
2. Information on the type plate of the affected products, especially type codes and serial numbers.
3. Your phone/fax numbers and e-mail address, so we can contact you in case of questions.

14.5 Kundenbetreuungsstellen - Sales & Service Facilities

Deutschland – Germany

vom Ausland:

(0) nach Landeskennziffer weglassen!

from abroad:

don't dial (0) after country code!

Vertriebsgebiet Mitte Germany Centre	SERVICE AUTOMATION	SERVICE AUTOMATION	SERVICE AUTOMATION
Bosch Rexroth Electric Drives and Controls GmbH Bgm.-Dr.-Nebel-Str. 2 / Postf. 1357 97816 Lohr am Main / 97803 Lohr Kompetenz-Zentrum Europa Tel.: +49 (0)9352 40-0 Fax: +49 (0)9352 40-4885	CALL ENTRY CENTER Helpdesk MO – FR von 07:00 - 18:00 Uhr from 7 am – 6 pm Tel. +49 (0) 9352 40 50 60 Fax +49 (0) 9352 40 49 41 service.svc@boschrexroth.de	HOTLINE 24 / 7 / 365 außerhalb der Helpdesk-Zeit out of helpdesk hours Tel.: +49 (0)172 660 04 06 oder / or Tel.: +49 (0)171 333 88 26	ERSATZTEILE / SPARES verlängerte Ansprechzeit - extended office time - ♦ nur an Werktagen - only on working days - ♦ von 07:00 - 18:00 Uhr - from 7 am - 6 pm - Tel. +49 (0) 9352 40 42 22
Vertriebsgebiet Süd Germany South Bosch Rexroth AG Landshuter Allee 8-10 80637 München Tel.: +49 (0)89 127 14-0 Fax: +49 (0)89 127 14-490	Vertriebsgebiet West Germany West Bosch Rexroth AG Regionalzentrum West Borsigstrasse 15 40880 Ratingen Tel.: +49 (0)2102 409-0 Fax: +49 (0)2102 409-406 +49 (0)2102 409-430	Gebiet Südwest Germany South-West Bosch Rexroth AG Service-Regionalzentrum Süd-West Siemensstr. 1 70736 Fellbach Tel.: +49 (0)711 51046-0 Fax: +49 (0)711 51046-248	
Vertriebsgebiet Nord Germany North Bosch Rexroth AG Walsroder Str. 93 30853 Langenhagen Tel.: +49 (0) 511 72 66 57-0 Service: +49 (0) 511 72 66 57-256 Fax: +49 (0) 511 72 66 57-93 Service: +49 (0) 511 72 66 57-783	Vertriebsgebiet Mitte Germany Centre Bosch Rexroth AG Regionalzentrum Mitte Waldecker Straße 13 64546 Mörfelden-Walldorf Tel.: +49 (0) 61 05 702-3 Fax: +49 (0) 61 05 702-444	Vertriebsgebiet Ost Germany East Bosch Rexroth AG Beckerstraße 31 09120 Chemnitz Tel.: +49 (0)371 35 55-0 Fax: +49 (0)371 35 55-333	Vertriebsgebiet Ost Germany East Bosch Rexroth AG Regionalzentrum Ost Walter-Köhn-Str. 4d 04356 Leipzig Tel.: +49 (0)341 25 61-0 Fax: +49 (0)341 25 61-111

Europa (West) - Europe (West)

vom Ausland: (0) nach Landeskenziffer weglassen, **Italien:** 0 nach Landeskenziffer mitwählen
from abroad: don't dial (0) after country code, **Italy:** dial 0 after country code

<p>Austria - Österreich</p> <p>Bosch Rexroth GmbH Electric Drives & Controls Stachegasse 13 1120 Wien Tel.: +43 (0) 1 985 25 40 Fax: +43 (0) 1 985 25 40-1459</p>	<p>Austria – Österreich</p> <p>Bosch Rexroth GmbH Electric Drives & Controls Industriepark 18 4061 Pasching Tel.: +43 (0)7221 605-0 Fax: +43 (0)7221 605-1220</p>	<p>Belgium - Belgien</p> <p>Bosch Rexroth NV/SA Henri Genessestraat 1 1070 Bruxelles Tel: +32 (0) 2 451 26 08 Fax: +32 (0) 2 451 27 90 info@boschrexroth.be service@boschrexroth.be</p>	<p>Denmark - Dänemark</p> <p>BEC A/S Zinkvej 6 8900 Randers Tel.: +45 87 11 90 60 Fax: +45 87 11 90 61</p>
<p>Denmark - Dänemark</p> <p>Bosch Rexroth A/S Engelsholmvej 26 8900 Randers Tel.: +45 36 77 44 66 Fax: +45 70 10 03 20 thomas.jansen@boschrexroth.dk</p>	<p>Great Britain – Großbritannien</p> <p>Bosch Rexroth Ltd. Electric Drives & Controls Broadway Lane, South Cerney Cirencester, Glos GL7 5UH Tel.: +44 (0)1285 863-000 Fax: +44 (0)1285 863-030 sales@boschrexroth.co.uk service@boschrexroth.co.uk</p>	<p>Finland - Finnland</p> <p>Bosch Rexroth Oy Electric Drives & Controls Ansatie 6 01740 Vantaa Tel.: +358 10 3441 000 Fax: +358 10 3441 506</p>	<p>France - Frankreich</p> <p>Bosch Rexroth SAS Electric Drives & Controls Avenue de la Trentaine (BP. 74) 77503 Chelles Cedex Tel.: +33 (0)164 72-63 22 Fax: +33 (0)164 72-63 20 Hotline: +33 (0)608 33 43 28</p>
<p>France - Frankreich</p> <p>Bosch Rexroth SAS Electric Drives & Controls ZI de Thibaud, 20 bd. Thibaud (BP. 1751) 31084 Toulouse Tel.: +33 (0)5 61 43 61 87 Fax: +33 (0)5 61 43 94 12</p>	<p>France – Frankreich</p> <p>Bosch Rexroth SAS Electric Drives & Controls 91, Bd. Irène Joliot-Curie 69634 Vénissieux – Cedex Tel.: +33 (0)4 78 78 53 65 Fax: +33 (0)4 78 78 53 62</p>	<p>France – Frankreich</p> <p>Tightening & Press-fit: Globe Techniques Nouvelles 143, Av. du Général de Gaulle 92252 La Garenne Colombes Tel.: +33 (0)1 41 19 33 33</p>	<p>Italy - Italien</p> <p>Bosch Rexroth S.p.A. Strada Statale Padana Superiore 11, no. 41 20063 Cernusco S/N.MI Tel.: +39 02 92 365 1 Service: +39 02 92 365 300 Fax: +39 02 92 365 500 Service: +39 02 92 365 516</p>
<p>Italy - Italien</p> <p>Bosch Rexroth S.p.A. Via Paolo Veronesi, 250 10148 Torino Tel.: +39 011 224 88 11 Fax: +39 011 224 88 30</p>	<p>Italy - Italien</p> <p>Bosch Rexroth S.p.A. Via Mascia, 1 80053 Castellamare di Stabia NA Tel.: +39 081 8 71 57 00 Fax: +39 081 8 71 68 85</p>	<p>Italy - Italien</p> <p>Bosch Rexroth S.p.A. Via del Progresso, 16 (Zona Ind.) 35020 Padova Tel.: +39 049 8 70 13 70 Fax: +39 049 8 70 13 77</p>	<p>Italy - Italien</p> <p>Bosch Rexroth S.p.A. Via Isonzo, 61 40033 Casalecchio di Reno (Bo) Tel.: +39 051 29 86 430 Fax: +39 051 29 86 490</p>
<p>Italy - Italien</p> <p>Tightening & Press-fit: TEMA S.p.A. Automazione Via Juker, 28 20025 Legnano Tel.: +39 0 331 4671</p>	<p>Netherlands – Niederlande/Holland</p> <p>Bosch Rexroth B.V. Kruisbroeksestraat 1 (P.O. Box 32) 5281 RV Boxtel Tel.: +31 (0) 411 65 16 40 Fax: +31 (0) 411 65 14 83 www.boschrexroth.nl</p>	<p>Netherlands - Niederlande/Holland</p> <p>Bosch Rexroth Services B.V. Technical Services Kruisbroeksestraat 1 (P.O. Box 32) 5281 RV Boxtel Tel.: +31 (0) 411 65 19 51 Fax: +31 (0) 411 67 78 14 Hotline: +31 (0) 411 65 19 51 services@boschrexroth.nl</p>	<p>Norway - Norwegen</p> <p>Bosch Rexroth AS Electric Drives & Controls Berghagan 1 or: Box 3007 1405 Ski-Langhus 1402 Ski Tel.: +47 64 86 41 00 Fax: +47 64 86 90 62 Hotline: +47 64 86 94 82 arn.t.kristian.barsten@boschrexroth.no</p>
<p>Spain – Spanien</p> <p>Goimendi Automation S.L. Parque Empresarial Zuatzu C/ Francisco Grandmontagne no.2 20018 San Sebastian Tel.: +34 9 43 31 84 21 - service: +34 9 43 31 84 56 Fax: +34 9 43 31 84 27 - service: +34 9 43 31 84 60 sat.indramat@goimendi.es</p>	<p>Spain - Spanien</p> <p>Bosch Rexroth S.A. Electric Drives & Controls Centro Industrial Santiga Obradors 14-16 08130 Santa Perpetua de Mogoda Barcelona Tel.: +34 9 37 47 94-00 Fax: +34 9 37 47 94-01</p>	<p>Spain - Spanien</p> <p>Bosch Rexroth S.A. Electric Drives & Controls c/ Almazara, 9 28760 Tres Cantos (Madrid) Tel.: +34 91 806 24 79 Fax: +34 91 806 24 72 fernando.bariego@boschrexroth.es</p>	<p>Sweden - Schweden</p> <p>Bosch Rexroth AB Electric Drives & Controls - Varuvägen 7 (Service: Konsumentvägen 4, Älfsjö) 125 81 Stockholm Tel.: +46 (0) 8 727 92 00 Fax: +46 (0) 8 647 32 77</p>
<p>Sweden - Schweden</p> <p>Bosch Rexroth AB Electric Drives & Controls Ekvändan 7 254 67 Helsingborg Tel.: +46 (0) 4 238 88 -50 Fax: +46 (0) 4 238 88 -74</p>	<p>Switzerland East - Schweiz Ost</p> <p>Bosch Rexroth Schweiz AG Electric Drives & Controls Hemrietstrasse 2 8863 Buttikon Tel. +41 (0) 55 46 46 111 Fax +41 (0) 55 46 46 222</p>	<p>Switzerland West - Schweiz West</p> <p>Bosch Rexroth Suisse SA Av. Général Guisan 26 1800 Vevey 1 Tel.: +41 (0)21 632 84 20 Fax: +41 (0)21 632 84 21</p>	

Europa (Ost) - Europe (East)

vom Ausland: (0) nach Landeskenziffer weglassen
from abroad: don't dial (0) after country code

Czech Republic - Tschechien Bosch -Rexroth, spol.s.r.o. Hviezdoslavova 5 627 00 Brno Tel.: +420 (0)5 48 126 358 Fax: +420 (0)5 48 126 112	Czech Republic - Tschechien Tightening & Press-fit: Bosch -Rexroth, spol.s.r.o. Stetkova 18 140 68 Praha 4 Tel.: +420 (0)241 406 675	Hungary - Ungarn Bosch Rexroth Kft. Angol utca 34 1149 Budapest Tel.: +36 (1) 422 3200 Fax: +36 (1) 422 3201	Poland – Polen Bosch Rexroth Sp.zo.o. ul. Jutrzenki 102/104 02-230 Warszawa Tel.: +48 (0) 22 738 18 46 Fax: +48 (0) 22 738 18 64
Poland – Polen Bosch Rexroth Sp.zo.o. Biuro Poznan ul. Dabrowskiego 81/85 60-529 Poznan Tel.: +48 061 847 64 62 /-63 Fax: +48 061 847 64 02	Romania - Rumänien East Electric S.R.L. Bdul Basarabia no.250, sector 3 73429 Bucuresti Tel./Fax:: +40 (0)21 255 35 07 +40 (0)21 255 77 13 Fax: +40 (0)21 725 61 21 eastel@rdsnet.ro	Romania - Rumänien Bosch Rexroth Sp.zo.o. Str. Drobety nr. 4-10, app. 14 70258 Bucuresti, Sector 2 Tel.: +40 (0)1 210 48 25 +40 (0)1 210 29 50 Fax: +40 (0)1 210 29 52	Russia - Russland Bosch Rexroth OOO Tschschjolowskoje Chaussee 100, Etage 11 105523 Moskau Tel.: +7-495-783 30 60 Fax: +7-495 783 30 69 brschrexroth.ru
Turkey - Türkei Bosch Rexroth Otomasyon San & Tic. A..S. Fevzi Cakmak Cad No. 3 34295 Sefaköy Istanbul Tel.: +90 212 411-13 00 Fax: +90 212 411-13 17 www.boschrexroth.com.tr	Turkey - Türkei Servo Kontrol Ltd. Sti. Perpa Ticaret Merkezi B Blok Kat: 11 No: 1609 80270 Okmeydani-Istanbul Tel: +90 212 320 30 80 Fax: +90 212 320 30 81 remzi.sali@servokontrol.com www.servokontrol.com	Slovakia - Slowakei Tightening & Press-fit: MTS, spol .s.r.o. 02755 Kriva 53 Tel.: +421 43 5819 161	Slowenia - Slowenien DOMEL Otoki 21 64 228 Zelezniki Tel.: +386 4 5117 100 Fax: +386 4 5117 357 brane.ozebek@domel.si

Australien, Süd-Afrika - Australia, South Africa

Australia - Australien AIMS - Australian Industrial Machinery Services Pty. Ltd. 28 Westside Drive Laverton North Vic 3026 Melbourne Tel.: +61 3 93 14 3321 Fax: +61 3 93 14 3329 Hotlines: +61 3 93 14 3321 +61 4 19 369 195 enquires@aimservices.com.au	Australia - Australien Bosch Rexroth Pty. Ltd. No. 7, Endeavour Way Braeside Victoria, 31 95 Melbourne Tel.: +61 3 95 80 39 33 Fax: +61 3 95 80 17 33 mel@rexroth.com.au	South Africa - Südafrika TECTRA Automation (Pty) Ltd. 100 Newton Road, Meadowdale Edenvale 1609 Tel.: +27 11 971 94 00 Fax: +27 11 971 94 40 Hotline: +27 82 903 29 23 georgv@tectra.co.za	South Africa - Südafrika Tightening & Press-fit: Jendarmark Automation 76A York Road, North End 6000 Port Elizabeth Tel.: +27 41 391 4735
---	--	--	--

Asien - Asia (incl. Pacific Rim)

<p>China</p> <p>Shanghai Bosch Rexroth Hydraulics & Automation Ltd. BRC Service Department No.55 Jinwan Road Jinqiao Industry Zone Shanghai 201206 - P.R.China Tel.: +86 21 38824688-749 Fax: +86 21 50555447 brcservice@boschrexroth.com.cn</p>	<p>China</p> <p>Shanghai Bosch Rexroth Hydraulics & Automation Ltd. 4/f, Marine Tower No.1, Pudong Avenue Shanghai 200120 - P.R.China Tel: +86 21 68 86 15 88 Fax: +86 21 68 86 05 99 +86 21 58 40 65 77 y.wu@boschrexroth.com.cn</p>	<p>China</p> <p>Bosch Rexroth (China) Ltd. Satellite Service Office Changchun Rm. 1910, Guangming Building No.336 Xi'an Rd., Chao Yang Distr. Changchun 130061 - P.R.China Tel.+Fax: +86 431 898 1129 Mobile: +86 139 431 92 659 shuhong.wang@boschrexroth.com.cn</p>	<p>China</p> <p>Bosch Rexroth (China) Ltd. Satellite Service Office Wuhan No. 22, Pinglanju, Milanyuan, Golden Harbor No. 236 Longyang Avenue Economic & Technology Development Zone Wuhan 430056 - P.R.China Tel.+Fax: +86 27 84 23 23 92 Mobile: +86 139 71 58 89 67 ym.zhu@boschrexroth.com.cn</p>
<p>China</p> <p>Bosch Rexroth (China) Ltd. Beijing Representative Office Xi San Qi Dong, De Sheng Mei Wai Hai Dian District Beijing 100096, P.R.China Tel.: +86 10 82 91 22 29 Fax: +86 10 82 91 81 09 yan.zhang@boschrexroth.com.cn</p>	<p>China</p> <p>Bosch Rexroth (China) Ltd. Guangzhou Repres. Office Room 3710-3716, Metro Plaza, Tian He District, 183 Tian He Bei Rd Guangzhou 510075, P.R.China Tel.: +86 20 87 55 00 30 +86 20 87 55 00 11 Fax: +86 20 87 55 23 87 andrew.wang@boschrexroth.com.cn</p>	<p>China</p> <p>Bosch Rexroth (China) Ltd. Dalian Representative Office Room 2005,Pearl River Int. Building No.99 Xin Kai Rd., Xi Gang District Dalian, 116011, P.R.China Tel.: +86 411 83 68 26 02 Fax: +86 411 83 68 27 02 jason.tan@boschrexroth.com.cn</p>	<p>China</p> <p>Tightening & Press-fit: C. Melchers GmbH & Co Shanghai Representation 13 Floor Est Ocean Centre No.588 Yanan Rd. East 65 Yanan Rd. West Shanghai 200001 Tel.: +86 21 63 52 88 48 Fax: +86 21 63 51 31 38 shermanxia@sh.melchers.com.cn</p>
<p>Hongkong</p> <p>Bosch Rexroth (China) Ltd. 6th Floor, Yeung Yiu Chung No.6 Ind Bldg. 19 Cheung Shun Street Cheung Sha Wan, Kowloon, Hongkong Tel.: +852 27 86 46 32 Fax: +852 27 42 60 57 Paul.li@boschrexroth.com.cn</p>	<p>India - Indien</p> <p>Bosch Rexroth (India) Ltd. Electric Drives & Controls Plot. No.96, Phase III Peenya Industrial Area Bangalore – 560058 Tel.: +91 80 41 17 0211 Fax: +91 80 83 97 374 pradeep.rs@boschrexroth.co.in</p>	<p>India - Indien</p> <p>Bosch Rexroth (India) Ltd. Electric Drives & Controls Advance House, II Floor Ark Industrial Compound Narol Naka, Makwana Road Andheri (East), Mumbai - 400 059 Tel.: +91 22 28 56 32 90 +91 22 28 56 33 18 Fax: +91 22 28 56 32 93 singh.op@boschrexroth.co.in</p>	<p>India - Indien</p> <p>Tightening & Press-fit: MICO Hosur Road Adugodi 560 030 Bangalore Karnataka Tel.: +91 80 22 99 28 86</p>
<p>India - Indien</p> <p>Bosch Rexroth (India) Ltd. S-10, Green Park Extension New Delhi – 110016 Tel.: +91 11 26 56 65 25 +91 11 26 56 65 27 Fax: +91 11 26 56 68 87 koul.rp@boschrexroth.co.in</p>	<p>Indonesia - Indonesien</p> <p>PT. Bosch Rexroth Building # 202, Cilandak Commercial Estate Jl. Cilandak KKO, Jakarta 12560 Tel.: +62 21 7891169 (5 lines) Fax: +62 21 7891170 - 71 rudu.karimun@boschrexroth.co.id</p>	<p>Japan</p> <p>Bosch Rexroth Corporation Service Center Japan 2125-1 atsukawado-cho Kasugai-shi Aichi-ken 486-0932, Japan Tel.: +81 568 35 7701 Fax: +81 568 35 7705</p>	<p>Japan</p> <p>Bosch Rexroth Corporation Electric Drives & Controls BOSCH Bldg. 4F, 3-6-7 Shibuya Shibuya-ku, Tokyo 150-0002, Japan Tel: +81 354 85 7240 Fax: +81 354 85 7241</p>
<p>Korea</p> <p>Bosch Rexroth-Korea Ltd. Electric Drives & Controls 1515-14 Dadae-Dong, Saha-gu Pusan Metropolitan City, 604-050 Tel.: +82 51 26 00 741 Fax: +82 51 26 00 747 eunkyong.kim@boschrexroth.co.kr</p>	<p>Korea</p> <p>Bosch Rexroth-Korea Ltd. Electric Drives and Controls Bongwoo Bldg. 7FL, 31-7, 1Ga Jangchoong-dong, Jung-gu Seoul, 100-391 Tel.: +82 234 061 813 Fax: +82 222 641 295</p>	<p>Korea</p> <p>Bosch Rexroth-Korea Ltd. Electric Drives & Controls 1515-14 Dadae-Dong, Saha-gu Ulsan, 680-010 Tel.: +82 52 256-0734 Fax: +82 52 256-0738 keonhyun.jeong@boschrexroth.co.kr</p>	<p>Korea</p> <p>Tightening & Press-fit: KVT Co., Ltd. 901, Daeryung Techno Town 8 481-11 Gasan-Dong Geumcheon-Gu Seoul, 153-775 Tel.: +82 2 2163 0231 9</p>
<p>Malaysia</p> <p>Bosch Rexroth Sdn.Bhd. 11, Jalan U8/82, Seksyen U8 40150 Shah Alam Selangor, Malaysia Tel.: +60 3 78 44 80 00 Fax: +60 3 78 45 48 00 hhlim@boschrexroth.com.my</p>	<p>Singapore - Singapur</p> <p>Bosch Rexroth Pte Ltd 15D Tuas Road Singapore 638520 Tel.: +65 68 61 87 33 Fax: +65 68 61 18 25 raymond.toh@boschrexroth.com.sg</p>	<p>Taiwan</p> <p>Bosch Rexroth Co., Ltd. Taichung Industrial Area No.19, 38 Road Taichung, Taiwan 407, R.O.C. Tel: +886 - 4 -235 08 383 Fax: +886 - 4 -235 08 586 jim.lin@boschrexroth.com.tw david.lai@boschrexroth.com.tw</p>	<p>Taiwan</p> <p>Bosch Rexroth Co., Ltd. Tainan Branch No. 17, Alley 24, Lane 737 Chung Cheng N.Rd. Yungkang Tainan Hsien, Taiwan, R.O.C. Tel: +886 - 6 -253 6565 Fax: +886 - 6 -253 4754 charlie.chen@boschrexroth.com.tw</p>
<p>Thailand</p> <p>NC Advance Technology Co. Ltd. 59/76 Moo 9 Ramintra road 34 Tharang, Bangkok, Bangkok 10230 Tel.: +66 2 943 70 62 +66 2 943 71 21 Fax: +66 2 509 23 62 Hotline +66 1 984 61 52 sonkawin@hotmail.com</p>			

Nordamerika – North America

USA Headquarters - Hauptniederlassung Bosch Rexroth Corporation Electric Drives & Controls 5150 Prairie Stone Parkway Hoffman Estates, IL 60192-3707 Tel.: +1 847 645-3600 Fax: +1 847 645-6201 servicebrc@boschrexroth-us.com repairbrc@boschrexroth-us.com	USA Central Region - Mitte Bosch Rexroth Corporation Electric Drives & Controls 1701 Harmon Road Auburn Hills, MI 48326 Tel.: +1 248 393-3330 Fax: +1 248 393-2906	USA Southeast Region - Südost Bosch Rexroth Corporation Electric Drives & Controls 2810 Premiere Parkway, Suite 500 Duluth, GA 30097 Tel.: +1 678 957-4050 Fax: +1 678 417-6637	USA SERVICE-HOTLINE - 7 days week/ 24 hrs day - +1-800-REXROTH +1 800 739 7684
USA Northeast Region – Nordost Bosch Rexroth Corporation Electric Drives & Controls 99 Rainbow Road East Granby, CT 06026 Tel.: +1 860 844-8377 Fax: +1 860 844-8595	USA West Region – West Bosch Rexroth Corporation Electric Drives & Controls 7901 Stoneridge Drive, Suite 220 Pleasanton, CA 94588 Tel.: +1 925 227-1084 Fax: +1 925 227-1081	Canada East - Kanada Ost Bosch Rexroth Canada Corporation 5345 Outer Drive unit 5 Windsor, Ontario Canada N9A 6J3 Tel.: +1 519 737 7393 Fax.: +1 519 737 9999	Canada East - Kanada Ost Bosch Rexroth Canada Corporation Automation Division 3426 Mainway Drive Burlington, Ontario Canada L7M 1A8 Tel.: +1 905 335 5511 Fax: +1 905 335 4184 (Main) +1 905 335 9803 (Serv.) automation.service@boschrexroth.ca automation.repair@boschrexroth.ca
Canada West - Kanada West Bosch Rexroth Canada Corporation 5345 Goring St. Burnaby, British Columbia Canada V7J 1R1 Tel. +1 604 205 5777 Fax +1 604 205 6944 automation.service@boschrexroth.ca automation.repair@boschrexroth.ca	CANADA SERVICE HOTLINE - 7 days week/ 24 hrs day - +1 905 335 5511	Mexico Bosch Rexroth Mexico S.A. de C.V. Calle Neptuno 72 Unidad Ind. Vallejo 07700 Mexico, D.F. Tel.: +52 55 57 54 17 11 Fax: +52 55 57 54 50 73 mario.hernandez@boschrexroth.com.mx	Mexico Bosch Rexroth S.A. de C.V. Calle Argentina No 3913 Fracc. las Torres 64930 Monterrey, N.L. Tel.: +52 81 83 49 80 91 +52 81 83 49 80 92 +52 81 83 49 80 93 Fax: +52 81 83 65 52 80

Südamerika – South America

Argentina - Argentinien Bosch Rexroth S.A.I.C. "The Drive & Control Company" Rosario 2302 B1606DLD Carapachay Provincia de Buenos Aires Tel.: +54 11 4756 01 40 +54 11 4756 02 40 +54 11 4756 03 40 +54 11 4756 04 40 Fax: +54 11 4756 01 36 +54 11 4721 91 53 victor.jabif@boschrexroth.com.ar	Argentina - Argentinien NAKASE SRL Servicio Tecnico CNC Calle 49, No. 5764/66 B1653AOX Villa Balester Provincia de Buenos Aires Tel.: +54 11 4768 42 42 Fax: +54 11 4768 42 42 111 Hotline: +54 11 155 307 6781 nakase@nakase.com	Brazil - Brasilien Bosch Rexroth Ltda. Av. Tégula, 888 Ponte Alta, Atibaia SP CEP 12942-440 Tel.: +55 11 4414 -56 92 +55 11 4414 -56 84 Fax sales: +55 11 4414 -57 07 Fax serv.: +55 11 4414 -56 86 alexandre.wittwer@rexroth.com.br	Brazil - Brasilien Bosch Rexroth Ltda. R. Dr.Humberto Pinheiro Vieira, 100 Distrito Industrial [Caixa Postal 1273] 89220-390 Joinville - SC Tel./Fax: +55 47 473 58 33 Mobil: +55 47 9974 6645 sergio.prochnow@boschrexroth.com.br
Columbia - Kolumbien Reflutec de Colombia Ltda. Calle 37 No. 22-31 Santafé de Bogotá, D.C. Colombia Tel.: +57 1 208 65 55 Fax: +57 1 269 97 37 reflutec@etb.net.co			

Rexroth
Bosch Group

Bosch Rexroth AG
Electric Drives and Controls
P.O. Box 13 57
97803 Lohr, Germany
Bgm.-Dr.-Nebel-Str. 2
97816 Lohr, Germany
Phone +49 (0)93 52-40-50 60
Fax +49 (0)93 52-40-49 41
service.svc@boschrexroth.de
www.boschrexroth.com



R911308429

Printed in Germany
DOK-CONTRL-IC*L40*****-PR03-EN-P