



PARVEX



**Brushless
Servo Drives**

**Brushless
Servo Motors**

ATEX Servo systems

DC Servo Drives

DC Servo Motors

**Electrospindle
synchronous motors**

SERVO DRIVES AND SERVO MOTORS

PRODUCT SELECTOR

SERVO DRIVES

	0	5 A	25 A	250 A
Compact positioning drive with integrated PLC	631 Series 0 to 6 A			
Motor control complete system with fieldbus interface options	635 Series 0 to 10 A			
High performance servo drives for single or multi axis applications	637f Series 0 to 30 A			
Brushless servo speed control for axis or spindle applications	DIGIVEX Drive Series 0 to 300 A			
Complete positioning drive for optimum control of brushless servo motors	DIGIVEX Motion Series 0 to 300 A			
Servo drive for DC motors	RTS Series 0 to 40 A			

new

SERVO MOTORS

	0	10 Nm	150 Nm	300 Nm
Brushless servo motors with high dynamic characteristics and exceptional quality of motion	NX, L and H Series 0.4 to 320 Nm			
ATEX approved brushless servo motors for potentially explosive atmospheres	EX Series 1.75 to 35 Nm*			
DC servo motors of rotor-disk or wound rotor type	AXEM and RS-RX 0.05 to 20 Nm			

	0	30 kW	65 kW	100 kW
Synchronous permanent magnet motors for high performance spindle applications	HV and HW Series 2 to 110 kW			

new

CONTENTS

SECTION 2		SERVO DRIVES	
2	631 Series : compact positioning drive. Ratings from 1 to 6A	6	Accessories for 631 and 635-637f Series
3	635 Series : positioning drive with fieldbus option. Ratings from 1 to 10A	7	630 Series - NX servo motor associations
4	637f Series : high performance servo drives for single or multi axis applications. Ratings from 2 to 30A	8	DμD/DLD : very compact drive. Ratings from 2A to 7.5A
		9	DIGIVEX Drive : single axis, multi axis and regenerative version servo drives Ratings from 2 to 300A
		10	DIGIVEX Motion : positioning servo drives with advanced possibilities and integrated PLC Ratings from 2 to 300A
		11	DIGIVEX Characteristics
		12	Accessories for DIGIVEX range
		13	DIGIVEX - NX servo motor associations
SECTION 2		BRUSHLESS AND DC SERVO MOTORS	
14	NX Series : new servo motor range from 0.45 to 64Nm. High dynamic characteristics	26	GX gearboxes for NX motor series. Low backlash range.
17	NX Series : construction and codification	28	GL gearboxes for NX motor series. Economical range
18	Hiperface option for NX Series	29	Accessories for NX, L and H Series
20	EX Series : ATEX approved servo motors for potentially explosive atmosphere	30	HV Series : synchronous motors for traditional spindle construction
22	Servo Motor Kit for custom OEM solution	32	HW Series : synchronous motors for high performance electrospindle
23	LS-HS Series : short motor series with higher inertia	34	AXEM Series : DC servo motors with rotor-disk
24	LX-HX Series : brushless servo motors up to 320Nm. High dynamic characteristics	36	RX Series : DC servo motors with wound rotor. Economical range
		38	RS Series : DC servo motors with wound rotor. High performance range
		40	RTS Series : drive for DC servo motors
		41	Accessories for DC servo systems
		42	Operator terminals
		43	Parvex Motion Explorer and EasyRider software

SSD DRIVES

A global group present in 60 countries...

SSD Drives, formerly Eurotherm Drives is an industry leading manufacturer of AC, DC, servo drives and servo motors. In 2000, the servo specialist Parvex joined the group as a division of SSD Drives, which expanded the product offering to high quality servo motors.

We are renowned for our wide range of reliable, innovative, state of the art products, applications experience, and global support.

The group is born in September 2002 from the buyout of the Eurotherm Drives Division of Invensys by its management team backed by a financial partner and banks.

From November 2004, the new group name is SSD Drives; Parvex has been renamed SSD Parvex.

Looking forward, our company has the critical mass and knowledge base to continue our pipeline of innovative technologies, key to building and growing our business.

1500 specialists in drives and servo systems , SSD Parvex motor quality



For almost 30 years, we have supplied drives to the leading OEMs and end users in industry. We develop and produce advanced servo motors and servo drives for the most demanding applications in which motion quality is the key point.

Now we offer a complete line of the world's most advanced AC, DC, and servo drives and motors. These products bring the right mix of features and functionality that were developed from over three decades of worldwide industry experience.

A strong industrial presence in Europe

A worldwide network of SSD Drives companies and agents ensure you get expert application and service support in over 40 countries. You can install our products wherever you are, with the confidence of full back up and support.

SSD Drives are particularly present in Europe and enjoy an excellent reputation. Our network is the link between SSD Drives and our customers, providing real sales and technical support within the shortest times.



A unique range of drives, servo motors and customised solutions...



SSD Drives offers you a complete range of motors and drives in the technology the most adapted to your requirements :

- Flux vector control with or without sensor
- Servo drives for brushless or DC servo motors
- Axis or spindle servo motors
- DC drives

To complete this standard range, SSD Parvex is organised to develop complete customised solutions :

- Servo motor kits
- Special servo motors and servo drives
- Drive system design service
- Field service and start-up assistance

631

1 to 6A

The 631 is much more than a basic brushless servo drive. With built-in motion controller, emc compliant filter, PLC functionality and even extended I/O option, it's a complete positioning system in a single module. The 631 is designed for direct connection to a 230Vac single phase supply without the need for any interposing transformer.



**1500 STEP INTEGRAL
MOTION CONTROLLER**

INTEGRAL EMC COMPLIANT FILTERS

INTEGRAL BRAKE SWITCH

DIRECT 230VAC SUPPLY

SIMULATED ENCODER OUTPUT

DIN RAIL OR DIRECT PANEL MOUNT

TECHNICAL SPECIFICATIONS

Power Supply – 220-240Vac ($\pm 10\%$)

Single Phase

Ambient – 0-40°C (derate 2%/°C >40°C to 50°C max.)

1000m ASL (derate 1%/100m to 4000m max.)

Type	Output current continuous (Arms)	Output current peak (Arms)
631-001-230-x	1.0	2.0
631-002-230-x	2.0	4.0
631-004-230-x	4.0	8.0
631-006-230-x	6.0	12.0

Integrated filter x = F ; No filter x = 0

Inputs/Outputs

4 - Configurable Digital Inputs (24V)

2 - Configurable Digital Outputs (24V)

1 - Analogue Input

Optional I/O Expander Module

8 - Configurable Digital Inputs/Outputs
(max. 4 outputs)

CANbus Input and Output

Resolver Feedback Input

Pulse Train Input and Output

Dimensions

H	W	D*
183	72.0	175

Fixing : mounting holes 5.5mm - use M5 fixings

*45mm must be allowed for connectors.

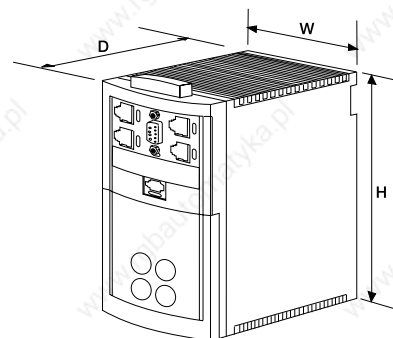

STANDARDS

CE marked

EN61800-3 (EMC compliance) with integral filter

EN50178 (safety, low voltage)



635 1 to 10A

TECHNICAL SPECIFICATIONS

635 Series

Power Supply – 220 - 230V ($\pm 10\%$ single or three phase up to 7A, three phase only 10A) 50 - 60 Hz $\pm 5\%$

Type	Output current continuous (Arms)	Output current peak (Arms)
635-K 01-3	1.0	2.0
635-K 03-3	2.5	5.0
635-K 05-3	5.0	10
635-K 07-3	6.5	10
635-K 10-3	10	20

Peak Output Current – Stated peak output currents are for a minimum 5 seconds

Ambient – 0 - 40°C (Derate 2%/°C up to 50°C max) Up to 1000m ASL (Derate 1%/100m up to 4000m max)

Input/Output

8 - Digital Inputs (inc 2 interrupts)
 5 - Digital Outputs (3 x Opto-coupled, 2 x Relay)
 2 - Analogue Inputs (-10V / 0 / +10V)
 1 - Analogue Output (0 - 10V)
 Motor Resolver Input
 Encoder (Configurable Input or Output)

Serial Communication Options

RS232 PROFIBUSDP
 RS422 INTERBUS S
 RS485 SUCOnet K
 CANbus

Input/Output Expansion Options

635 - Additional 5 Digital Inputs/2 Digital Outputs

Torque, speed, position or motion control are all standard operations of the 635 series ac brushless servo drive – without the need for external controllers. Each has its own internal power supply for direct connection to 230V ac supplies and is available as part of a total servo package including motors, servo gearboxes and interconnecting cables.

The 635 is available as either individual compact modules or as rack mounted assemblies with up to 9 drives in a single rack.



Dimensions				
		A	B	C
635	1 to 6.5 A	91	249	216.5
635	10 A	106.3	249	216.5

Allow extra 70mm in front of unit for plugs/cables.

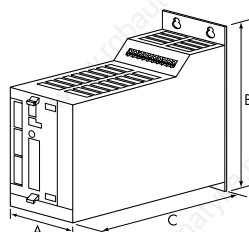

STANDARDS

CE marked
 EN61800-3 (EMC compliance) with integral filter
 EN50178 (safety, low voltage)



1500 STEP INTERNAL MOTION CONTROLLER

DIRECT 230VAC SUPPLY

MODULE OR RACK MOUNTED

SIMPLE COMMISSIONING AND PROGRAMMING SOFTWARE

FIELD BUS COMMUNICATION OPTIONS

637f**new****2 to 30A**

The new 637f series is servo drives with integrated motion controller designed for the most demanding servo systems.

Their ultra-fast control loops and process bus make them adapted to single or multi axis applications.

Their EN954-1 category 3 safety input and their second optional application bus simplify their integration into machine.

Furthermore the 637f drive integrate advanced PLC functions which can be built up with various input/output options.

Available as compact version, the 637f series is also proposed as rack version integrating up to 9 axis for 230 or 400Vac power supply.



EN954-1 CAT. 3 SAFETY OPTION

MULTI AXIS SYNCHRONISATION THROUGH PROCESS BUS

APPLICATION BUS : PROFIBUS-DP, DEVICENET, ...

1500 STEP INTERNAL MOTION CONTROLLER

ELECTRONIC CAMS

SIMPLE COMMISSIONING AND PROGRAMMING SOFTWARE

HIPERFACE AND SSI ENCODER INPUT

230V OR 400V SUPPLY

TECHNICAL SPECIFICATION

637f Series

Power supply - 380-460V ($\pm 10\%$) ; three phase

Model	Output current continuous (Arms)	Output current peak (Arms)
637f K 02-x	2.0	4.0
637f K 04-x	4.0	8.0
637f K 06-x	6.0	12
637f K 10-x	10	20
637f K 16-6	16	32
637f K 22-6	22	44
637f K 30-6	30	60

x=3 for 230V; x=6 for 400V

* Except for 10A rating (637f K 10-3), three-phase only

Peak Output Current – Stated peak output currents are for a minimum 5 seconds

Ambient – 0 - 40°C (Derate 2%/°C up to 50°C max) Up to 1000m ASL (Derate 1%/100m up to 4000m max)

Control

Current loop - 105 μ s

Speed loop - 105 μ s

Position loop - 105 μ s

Multi axis synchronisation through process bus

Virtual master axis

Multi axis synchronisation

Embedded PLC functions

Programmable electronic cam

Trajectory generator - 3 independent blocks

Input/Output

8 - Digital Input (inc 2 interrupts)

5 - Digital Output (3 x opto-coupled, 2 x relay)

2 - Analogue input (0-10V, +/-10V)

2 - Analogue output (+/-10V)

Resolver feedback (standard) or Hiperface (option)

Configurable encoder terminal :

Incremental encoder input

Incremental encoder output

Absolute single or multi turn SSI encoder input

RS232 (COM1) serial communication port

Hiperface option

4096 revolution absolute encoder - 1048576 inc. per rev.

Input/Output expansion options

Additional 14 Digital inputs/10 Digital outputs

Application communication option (COM2)

PROFIBUS-DP

SUCOnet K

DeviceNet

RS485

CANopen DS402

RS232

INTERBUS S

Inter axis communication option (COM3)

CANopen card

CANopen card + 4 Digital Input/4 Digital Output expansion

EN954-1 Category 3 safety option

637f SERVO DRIVES

2 to 30A

Dimensions

		A	B	C*
637f	1 to 10 A	61.5	400	280
637f	16 to 30 A	104	400	280

*Allow extra 70mm in front of unit for plugs/cables.

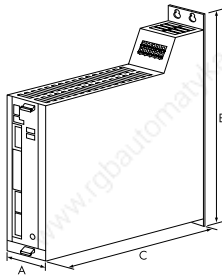

STANDARDS

CE marked
 EN61800-3 (EMC compliance) with integral filter
 EN50178 (safety, low voltage)



637f sets a new standard for performance

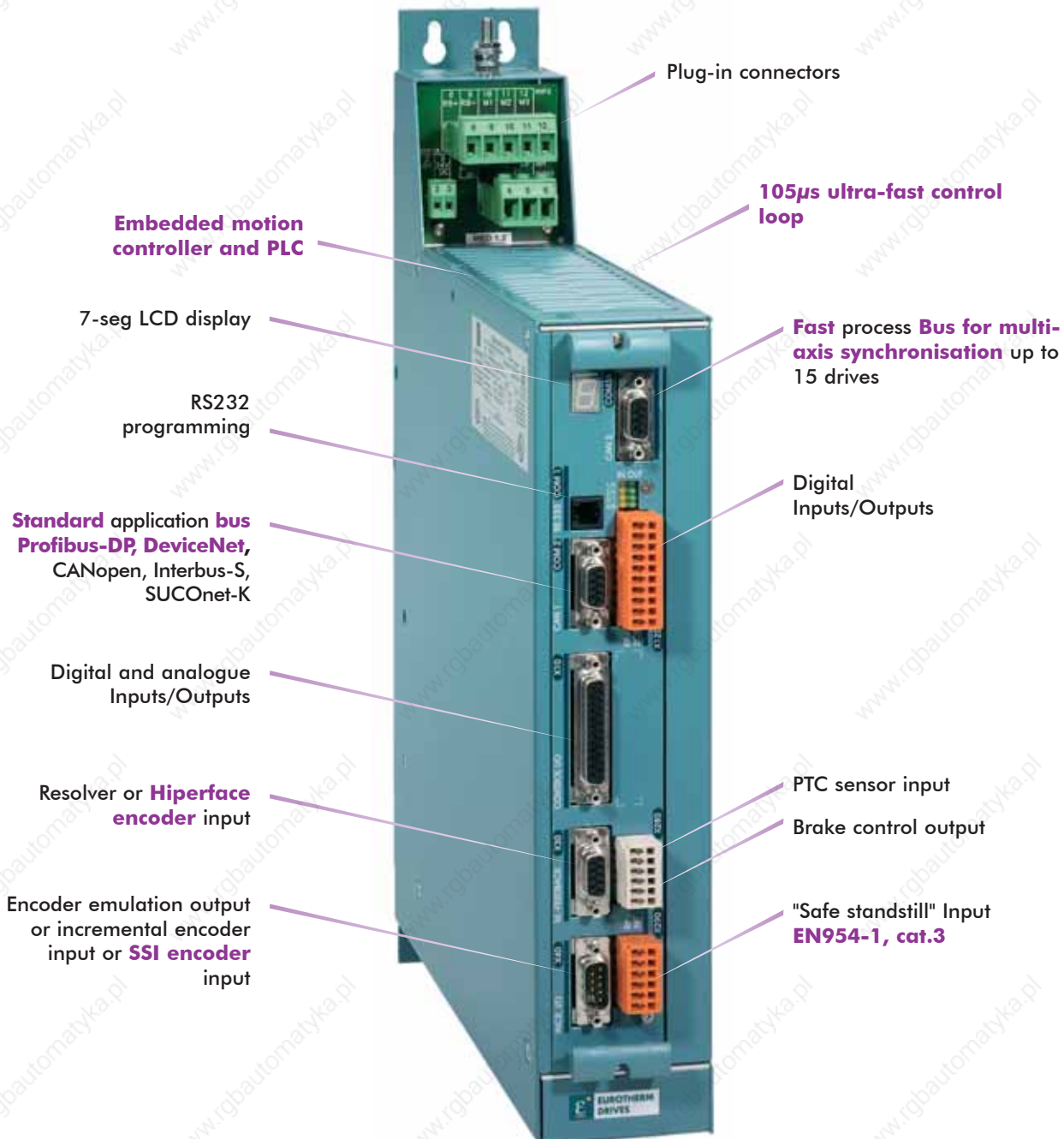

SERVO DRIVES

631, 635 AND 637f



631, 635 and 637f

COMPLETE PVC SCREENED CABLE SETS WITH CONNECTORS

Power

Power cable for ACG, compact version drive	KMB2-GM2n-K-xx
Power cable for ACG, rack version drive	KMB2-GM2n-R-xx
Power cable for NX1, NX2	220170R12xx
Power cable for NX2, NX3, NX4, NX6 (I < 15A)	220172R42xx
Power cable for NX3, NX4, NX6 (I < 22A)	220172R43xx

Resolver

Resolver cable for ACG	KRT-GMR-xx
Resolver cable for NX1, NX2	220170R21xx
Resolver cable for NX2, NX3, NX4, NX6, NX8	220172R61xx

xx = length in m; standard length 2, 5, 10m.

FERRITES

Ferrite for cable length > 15m (I < 10A)	FR3
Ferrite for cable length > 15m (I > 10A)	FR6

COM2 COMMUNICATION OPTION

RS232 communication board	RP232
RS422 communication board	RP422
RS485 communication board	RP485
CAN / CAN OPEN communication board	RPCAN
Profibus DP communication board	RPPDP
DeviceNet communication board	RPDEV
SUCOnet-K communication board	RPSUC
Interbus-S communication board	RPIBS

COM3 COMMUNICATION OPTION FOR 637F

RPM2CA/637f-8 CanOpen for 637f 02A to 10A	RP 2CA-8
RPM2CA/637f-16 CanOpen for 637f 16A to 30A	RP 2CA-16
RPM2CB/637f-8 CanOpen for 637f 02A to 10A	RP 2CB-8
RPM2CB/637f-16 CanOpen for 637f 16A to 30A	RP 2CB-16

EXTENDED I/O OPTION BOARD

5 I / 2 O digital for 635	RPEA5
14 I / 10 O digital for 637f	RPEAE
External plug for RPEAE	SUB D-HD 26 S/M

SAFETY MODULE OPTION FOR 637F

EN954-1 standard Cat.3 safety module	RP SBT
--------------------------------------	--------

EMC FILTERS FOR 635/637F

230V 12A 1 phase RFI filter	LNFE1-230/012
230 or 400V 8A 3 phases RFI filter	LNFB3-480/008
230 or 400V 18A 3 phases RFI filter	LNFB3-480/018
400V 33A 3 phases RFI filter	LNFB3-480/033
400V 46A 3 phases RFI filter	LNFB3-480/046
400V 60A 3 phases RFI filter	LNFB3-480/060
400V 82A 3 phases RFI filter	LNFB3-480/082
400V 142A 3 phases RFI filter	LNFB3-480/142

EMC KITS

02A to 10A kit for 637f	EMVBU-D6K08V1
16A to 32A kit for 637f	EMVBU-D6K16V1
01A to 07A kit for 635	EMVBU-DEK15V1
10A kit for 635	EMVBU-DEK18V1

OUTPUT CHOKE (POWER CABLE LENGTH > 50M)

Remark : Ferrite has also to be mounted	
Output choke I _n ≤ 8A	E32-0011
Output choke I _n ≤ 24A	E32-0031
Output choke I _n ≤ 35A	E32-0046

BRAKE RESISTOR

Resistor 100W 100Ω	B100/100-6
Resistor 300W 33Ω	B300/33-6
Resistor 560W 26Ω	B560/26-6

631 CABLES

CAN bus terminator plug (120ohms)	S-CAN-631-AS
CAN Peer to Peer connection for 631	K 631 X20-0.1
Incremental Peer to Peer connection for 631	K 631 X40-0.1

SOFTWARE

EASYRIDER / TESIWIN / PROGRAMMING EXAMPLES	CD SERVO
PC to 635 drive cable	Kn PC/D-02.0
PC to 631 and 637f drive cable	Kn PC/631-03.0

MMI (MAN MACHINE INTERFACE)

4x20 character BT MMI	IBT T CAN -W
MMI to 631 interconnecting cable with connectors	K IBT 1*631-xx
MMI to 635/637f interconnecting cable with connectors	K IBT n*630-xx

xx = length in m; standard length 2 and 5m.

NX - 630 AND EX - 630 ASSOCIATIONS

630 drives are easily combined to NX and EX brushless servo motors (see page 14 and 20) to meet requirements of various servo system applications.



NX and EX Associations - 631/635 / 230V

Motor	M ₀ (N.m)	I ₀ (A _{RMS})	M _N (N.m)	I _N (A _{RMS})	N _{MAX} (tr/min)	M _{MAX} (N.m)	I _{MAX} (A _{RMS})	630 drive rating
NX SERVO MOTORS								
NX110EAP	0.45	1.0	0.33	0.8	6000	0.92	2.0	1/2
NX110EAP	0.45	1.0	0.33	0.8	6000	1.3	3.0	2/4
NX205EAV	0.45	1.0	0.37	0.8	5000	0.91	2.0	1/2
NX205EAS	0.45	1.3	0.29	1.0	7500	1	3.1	2/4
NX210EAT	1	1.3	0.8	1.1	4000	2.8	4.0	2/4
NX210EAP	1	2.0	0.61	1.3	6000	1.9	4.0	2/4
NX210EAP	1	2.0	0.61	1.3	6000	2.4	5.0	2.5/5
NX310EAP	2	1.4	1.9	1.3	2300	5.2	4.0	2/4
NX310EAK	2	2.5	1.7	2.1	4000	3.8	5.0	2.5/5
NX310EAK	2	2.5	1.7	2.1	4000	5.7	8.0	4/8
NX420EAP	4	2.8	3.8	2.7	2300	10.3	8.0	4/8
NX420EAJ	4	4.9	3.4	4.2	4000	8.0	10.0	5/10
NX420EAJ	4	4.9	3.4	4.2	4000	9.2	12.0	6/12
NX430EAJ	5.5	5.3	4.7	4.5	3200	10.2	10.0	6.5/10
NX430EAF	5.5	6.7	4.3	5.3	4000	15.1	20.0	10/20
NX620EAR	8	5.3	7.4	5.0	2200	15.1	10.0	6.5/10
NX620EAJ	8	9.9	6.1	7.9	4000	16.0	20.0	10/20
NX630EAR	12	5.7	11.5	5.5	1450	21.4	10.0	6.5/10
NX630EAK	11	10	10.2	9.2	2800	22.3	20.0	10/20
EX SERVO MOTORS FOR EXPLOSIVE ATMOSPHERE								
EX310EAP	1.7	1.2	1.7	1.2	2300	4.1	3	2/4
EX310EAK	1.7	2.2	1.5	2.0	4000	3.5	5	2.5/5
EX420EAP ⁽²⁾	3.5	2.5	3.2	2.2	2300	7.8	5.7	4/8
EX420EAJ ⁽²⁾	3.5	4.3	2.7	3.3	4000	8.3	10.6	6/12
EX430EAJ ⁽²⁾	4.8	4.6	3.7	3.6	3200	10.8	10.6	6/12
EX430EAF ⁽²⁾	4.8	5.8	3.3	4.1	4000	11.6	14.5	10/20
EX620EAO	7	5.5	5.5	4.5	2500	15.5	12	6/12
EX630EAI	10.4	10	7.2	7.3	3000	21.3	20	10/20
EX820EAR ⁽²⁾	14	9.6	11.5	8	2200	26.8	20	10/20

NX and EX Associations - 637f / 400V

Motor	M ₀ (N.m)	I ₀ (A _{RMS})	M _N (N.m)	I _N (A _{RMS})	N _{MAX} (tr/min)	M _{MAX} (N.m)	I _{MAX} (A _{RMS})	637f drive rating
NX SERVO MOTORS								
NX205EAV	0.45	1	0.29	0.7	7500	0.9	2.0	1/2
NX210EAT	1	1.3	0.61	0.9	6000	2.8	4.0	2/4
NX310EAP	2	1.4	1.7	1.2	4000	5.1	4.0	2/4
NX420EAV	4	1.4	3.8	1.4	2000	10.3	4.0	2/4
NX420EAP	4	2.8	3.4	2.4	4000	10.3	8.0	4/8
NX430EAV	5.5	1.4	5.4	1.4	1000	14.4	4.0	2/4
NX430EAP	5.5	2.8	4.8	2.5	3000	14.4	8.0	4/8
NX430EAL	5.5	3.8	4.3	3.0	4000	11.2	8.0	4/8
NX430EAL	5.5	3.8	4.3	3.0	4000	15.8	12.0	6/12
NX620EAV	8	2.8	7.5	2.7	2000	21.2	8.0	4/8
NX620EAR	8	5.3	6.2	4.3	3900	17.8	12.0	6/12
NX620EAJ	8	9.9	5.6	7.2	4500	16.0	20.0	10/20
NX620EAJ	8	9.9	5.6	7.2	4500	23.3	32.0	16/32
NX630EAV	12	2.8	11.6	2.7	1350	31.7	8.0	4/8
NX630EAR	12	5.7	10.3	5.0	2700	25.3	12.0	6/12
NX630EAN	12	8.6	8.3	6.2	4000	27.0	20.0	10/20
NX630EAN	12	8.6	8.3	6.2	4000	33.1	26.0	16/32
NX820EAX	16	5.2	14.7	4.8	1900	34.2	12.0	6/12
NX820EAR	16	11	12.9	9.1	3900	40.7	32.0	16/32
NX840EAX	28	10.1	23.2	8.5	2100	53.7	20.0	10/20
NX840EAK	28	16.8	18.5	11.5	3500	51.7	32.0	16/32
NX860EAJ	41	18.6	27.4	12.8	2600	92	44.0	22/44
NX860VAJ ⁽¹⁾	64	29.3	50.5	23.2	2600	117	60.0	30/60
EX SERVO MOTORS FOR EXPLOSIVE ATMOSPHERE								
EX310EAP	1.7	1.2	1.5	1.1	4000	3.9	2.8	2/4
EX420EAV ⁽²⁾	3.5	1.2	3.2	1.2	2000	7.7	2.8	2/4
EX420EAP ⁽²⁾	3.5	2.5	2.7	1.9	4000	7.8	5.7	4/8
EX430EAP ⁽²⁾	4.8	2.5	3.9	2.0	3000	10.7	5.7	4/8
EX430EAL ⁽²⁾	4.8	3.3	3.3	2.3	4000	11.1	8.0	4/8
EX620EAO	7	5.5	3.1	2.7	4300	14.7	11.3	6/12
EX630EAY	10.4	5.5	7.4	4.1	2900	21.8	11.3	6/12
EX630EAN	10.4	7.5	5.2	4.1	4000	26.0	18.7	10/20
EX820EAW ⁽²⁾	14	5.6	11.5	4.6	2200	27.3	11.3	6/12
EX820EAR ⁽²⁾	14	9.6	8.6	6.1	3600	31.1	22.6	16/32
EX840EAX ⁽²⁾	24.5	8.8	15.9	5.9	2100	58.4	22.1	16/32
EX840EAK ⁽²⁾	24.5	14.7	5.0	3.5	3300	58.4	36.8	22/44
EX860EAJ ⁽²⁾	35	15.8	12.0	5.9	2600	84.5	39.7	22/44

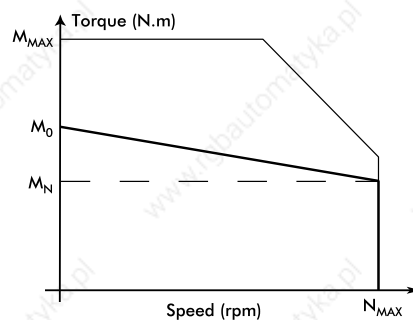

230V AND 400V POWER SUPPLY

LARGE CHOICE OF TORQUE
AND SPEED

ADAPTED CONNECTION

DIGIVEX DRIVE D μ D/DLD

2 to 7.5A

D μ D and DLD are specifically developed for low power applications where optimum quality of control and very compact design are needed.

Associated to NX servo motors, they offer a powerful and economical servo system solution.



DIRECT 230 VAC POWER SUPPLY

INTEGRATED EMC FILTER

INTEGRATED BRAKING RESISTOR

HIGH COMPACTY

7-SEG LCD DISPLAY

**EASY PARAMETER SETTING WITH
PARVEX MOTION EXPLORER**

TECHNICAL SPECIFICATIONS

Power supply - 230Vac \pm 10%, single or three phase ; 50/60Hz

Ambient - 0-40°C (derate 20%/10°C up to 60°C max)
Up to 1000m ASL (derate 1%/100m up to 4000m max)

Braking - Integrated resistor, connection of DC bus voltage in multi D μ D/DLD applications for higher braking capacity.

D μ D

NX1, NX2 and NX3 servo motor control

Input/Output

2- Analog input (14 bits and 10 bits ; \pm 10V diff.)

1- Analog output (\pm 5V), free assignment

3- Opto-isolated digital input

2- Opto-isolated digital output

Resolver input

Incremental encoder emulation output

DLD

Input/Output

2- Analog input (14 bits and 10 bits ; \pm 10V diff.)

2- Analog output (\pm 10V), free assignment

5- Opto-isolated digital input

3- Opto-isolated digital output

Resolver input

230Vac auxiliary input

Incremental encoder emulation output

Type	Output current continuous (A)	Output current peak (A)	Mechanical power (W)
DμD 230V single phase 50/60 Hz			
DUD13M02R	2	4	375
DLD			
230V single phase 50/60 Hz			
DLD13M02R	2	4	375
DLD13M04R	4	8	750
230V three phase 50/60 Hz			
DLD13002R	2	4	375
DLD13004R	4	8	750
DLD13007R	7.5	15	1500

DIMENSIONS

Type	H (mm)	W (mm)	D (mm)	Weight (kg)
D μ D	195	40	153	0.6
DLD	195	60	161	1.3

STANDARDS

CE marked

UL and cUL US LISTED (DLD)

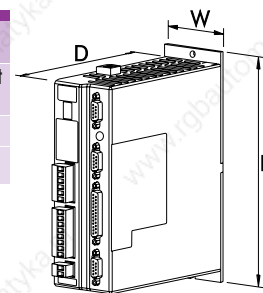

DIGIVEX DRIVE DSD/DMD/DPD 2 to 300A

TECHNICAL SPECIFICATIONS

Power supply - 230Vac $\pm 10\%$, single or three phase, 400Vac $\pm 10\%$, three phase; 50/60Hz

Ambient - 0-40°C (derate 20%/10°C up to 60°C max)

Up to 1000m ASL (derate 1%/100m up to 4000m max)

Braking -

DSD : Integrated or external resistor

DMD : Integrated or external resistor or regenerative

DPD : Regenerative

Input/Output

2- Analog input (16 bits and 10 bits ; $\pm 10V$ diff.)

2- Analog output ($\pm 10V$), free assignment

4- Opto-isolated digital input

3- Opto-isolated digital output

Resolver input

Incremental encoder emulation output ; SSI ; SinCos

230Vac or 400Vac auxiliary input

Characteristics

Please refer to page 11

STANDARDS

CE marked

DIGIVEX Drive are available for power range from 0.37kW to 120kW and for 230V and 400V power supply.

Dedicated to the torque or speed control of axis or spindle brushless motors, DIGIVEX Drive can be delivered in single-axis or multi-axis format.

RANGE			
Type	Output current	Structure	Control
DSD	2 to 60A	single-axis	Speed
DMD	2 to 32A	multi-axis	Speed
DPD	50 to 300A	single-axis	Speed

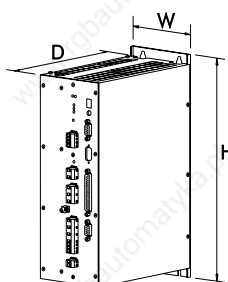

DIMENSIONS			
Type	H (mm)	W (mm)	D (mm)
DSD			
Rating			
2, 4 and 7.5 A	328	78	222
8 and 15 A	328	109.5	222
16 A	328	133	222
30 A	328	133	226
32 A	328	168	226
60 A	328	168	235
DMD			
Rack			
DRA3165 - 3 axis	303	315	270
DRA3168 - 6 axis	303	483	270
DRA3128 - 13 axis	597	483	271
DPD			
Rating			
50 A	438	202	244
100 and 150 A	474	483	343
200 A and 300 A	878	540	343

**DIRECT 230VAC AND 400VAC
POWER SUPPLY**

**SINGLE-AXIS OR
MULTI-AXIS VERSION**

**INTEGRATED RESISTOR
OR REGENERATIVE BRAKING**

**HIGH RESOLUTION
ANALOG INPUT**

**INTEGRATED FILTERS AND
FEED FORWARD**

**COMPLETE INTEGRATED
MONITORING WITH
PARVEX MOTION EXPLORER**

DIGIVEX Motion DSM/DMM/DPM

2 to 300A

The DIGIVEX Motion servo drives integrate in one compact unit the functions of speed controller, motion controller and PLC as well as powerful CANopen or PROFIBUS network possibilities.

The DIGIVEX Motion have the same electrical characteristics as the DIGIVEX Drive and are available in single or multi axis version.

RANGE			
Type	Output current	Structure	Control
DSM	2 to 60A	single-axis	Position
DMM	2 to 32A	multi-axis	Position
DPM	50 to 300A	single-axis	Position



COMPLETE POSITIONING DRIVE

**INTEGRATED PLC AND
MOTION PROGRAM**

**REAL TIME MULTI-TASKING
STRUCTURE**

**DIRECT 230VAC AND 400VAC
POWER SUPPLY**

SINGLE AND MULTI-AXIS VERSION

**INTEGRATED OR
REGENERATIVE BRAKING**

CANOPEN AND PROFIBUS

TECHNICAL SPECIFICATIONS

Power Supply - 230Vac $\pm 10\%$, single or three phase, 400Vac $\pm 10\%$, three phase ; 50/60Hz

Ambient - 0-40°C (derate 20%/10°C up to 60°C max)
Up to 1000m ASL (derate 1%/100m up to 4000m max)

Braking -

DSM : Integrated or external resistor

DMM : Integrated or external resistor or regenerative

DPM : Regenerative

Input/Output

1- Analog input (14 bits ; $\pm 10V$ diff.)

1- Analog output ($\pm 10V$), free assignment

16- Opto-isolated digital input (from which 4 interruptive inputs), free assignment

8- Opto-isolated digital output, free assignment

Resolver input

Incremental encoder input ; SinCos

Incremental encoder emulation output

230Vac or 400Vac auxiliary supply

Field bus

CANopen (DS 301 and DSP 402)

PROFIBUS (DP-V0 and DP-V1 ; PROFIdrive V2.0 and PROFIdrive V3.0 Class 3 and 4)

Characteristics

Please refer to page 11

STANDARDS

CE marked

DIMENSIONS

Type	H (mm)	W (mm)	D (mm)
DSM			
Rating			
2, 4 and 7.5 A	328	78	222
8 and 15 A	328	109.5	222
16 A	328	133	222
30 A	328	133	226
32 A	328	168	226
60 A	328	168	235
DMM			
Rack			
DRA3165 - 3 axis	303	315	270
DRA3168 - 6 axis	303	483	270
DRA3128 - 13 axis	597	483	271
DPM			
Rating			
50 A	438	202	244
100 and 150 A	474	483	343
200 A and 300 A	878	540	343

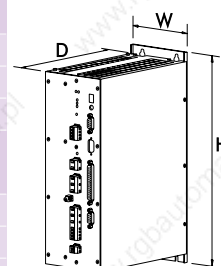

SERVO DRIVES

DIGIVEX characteristics

Single-axis DSD / DSM

Type	Output current continuous (A)	Output current peak (A)	Mechanical power (W)
230V single phase 50/60 Hz			
DSD13M02 / DSM13M02	2	4	375
DSD13M04 / DSM13M04	4	8	750
DSD13M07 / DSM13M07	7.5	15	1500
230V three phase 50/60 Hz			
DSD13004 / DSM13004	4	8	750
DSD13007 / DSM13007	7.5	15	1500
DSD13015 / DSM13015	15	30	3000
DSD13030 / DSM13030	30	60	6000
DSD13060 / DSM13060	60	100	12000
400V three phase 50/60 Hz			
DSD16002 / DSM16002	2	4	750
DSD16004 / DSM16004	4	8	1500
DSD16008 / DSM16008	8	16	3000
DSD16016 / DSM16016	16	32	6000
DSD16032 / DSM16032	32	64	12000



Multi-axis DMD / DMM 400V three phase 50/60 Hz

Module	Output current continuous (A)	Output current peak (A)	Width (E*)
DMD06002 / DMM06002	2	4	Simple 11E
DMD06004 / DMM06004	4	8	Simple 11E
DMD06008 / DMM06008	8	16	Simple 11E
DMD06016 / DMM06016	16	32	Double 22E
DMD06032 / DMM06032	32	64	Triple 33E
Power supply	Power (kW)	Braking	Width (E*)
DPS0612	12	internal	18E
DPS0625	25	internal / external	18E
DPS0615	15	regenerative	18E

*1E=5.08mm - example : 1x13 axis rack (DRA 3128) will integrate 1 power supply and 13 simple modules.



Power single axis (regenerative) DPD / DPM 400V three phase 50/60 Hz

Type	Output current continuous (A)	Output current peak (A)	Mechanical power (kW)
DPD27050 / DPM27050	50	80	20
DPD17100 / DPM17100	100	120	40
DPD17150 / DPM17150	150	150	60
DPD17200 / DPM17200	200	200	80
DPD17300 / DPM17300	300	300	120



DIGIVEX Drive and DIGIVEX Motion accessories

CABLES

Power cable with connectors*

Power cable with Molex motor connector for NX1, NX2 and I < 8Å	220154R12xx
Power cable with motor connector for NX1, NX2 and I < 8Å	220154R32xx
Power cable with motor connector for NX2, NX3, NX4, NX6 and I < 4Å	220049R49xx
Power cable with motor connector for NX3, NX4, NX6 and I < 8Å	220049R42xx
Power cable with motor connector for NX4, NX6, NX8 and I < 32Å	220049R43xx

Resolver cable with connectors*

Resolver cable with Molex motor connector and Sub-D for NX1, NX2	220154R21xx
Resolver cable with motor connector and Sub-D for NX	220049R61xx

Input/Output cables and communication cables

Encoder emulation cable (except DμD) 1 Sub-D	DIG04546R2xx
Input/Output cable 1 Sub-D	DIG04544R2xx
RS232C equipped cable for DLD, DSD, DMD and DPD 2 Sub-D	CB 90001
RS232C equipped cable for DμD 1 Sub-D and 1 RJ9	CB 90002
CANopen cable for DIGIVEX Motion 2 Sub-D	DIG05982R1xx
120 ohms CAN terminator plug	DIG05984R100
PROFIBUS cable for DIGIVEX Motion	CB 08320
PROFIBUS 90° plug	AC 62001
PROFIBUS 180° plug	AC 62002
USB cable for PC - USBPRO interface connection	CB 90003

EMC FILTERS FOR DIGIVEX (except DμD and DLD)

EMC filter 1Ph xx A (xx = 06 or 16)	FR 010xx
EMC filter 3Ph xx A (xx = 16, 36 or 64)	FR 030xx
EMC filter 3Ph book-sized xxA (xx = 08, 16 or 36)	FR 036xx
EMC filter 3Ph xxx A (xxx = 100 or 200)	FR 03xxx

EXTERNAL BRAKING RESISTOR FOR DIGIVEX

2kW 27ohms external resistor	RE 91001
4.5kW 12ohms external resistor	RE 91002

BOARD AND ACCESSORIES FOR DIGIVEX Drive (except DμD and DLD)

Encoder emulation board	SC 6631
SSI encoder board	SC 6637
Indexing board	SH 6601
Indexing + SinCos encoder emulation board	SC 6643
7-seg display	SS 6611
Dialog terminal	DTP001

BOARD AND COMMUNICATION INTERFACE FOR DIGIVEX Motion

Encoder input board	SC 6638
Encoder emulation board	SC 6639
SinCos input board	SC6645
RS232C - CAN interface	CRS232B
RS232C - CAN interface (DIN mounting)	CIM03B
RS232-CAN adaptor	RS232CAN
USB - PROFIBUS interface	USBPRO
PCI board for PC PCI - PROFIBUS interface	PCIPRO
PCMCIA board for PC PCMCIA - PROFIBUS interface	PCMCIAPRO
RS232-PROFIBUS adaptor	RS232PRO

SOFTWARE

Parvex Motion Explorer software	PMEMCD
CAM function license	DMLCAM
Position control with interpolation license	DMLPI

CANopen OPERATOR TERMINAL AND CABLE

2X16 characters terminal	DTP002
4x20 characters terminal (VT150)	DVT150C
5.7" graphic touch screen terminal (VT505)	DVT505C
VT Programming software, accessories and documentation	DVTWINTKITF
CANopen connecting cable 1Sub-D 9pts	DIG06755R1xx



* Cables and connectors are described on page 29 "Brushless - Accessories"

** xx cable length in m ; standard xx= 01, 02, 05, 10 meters

NX - DIGIVEX & EX - DIGIVEX ASSOCIATIONS

SERVO DRIVES

For all kind of servo applications, DIGIVEX servo drives offer the perfect control of NX or EX brushless servo motors and allow servo system to reach optimum performances. (For NX and EX description, please refer to page 14 and 20).

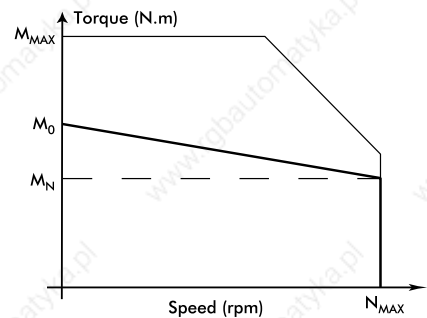

230V AND 400V POWER SUPPLY

**LARGE CHOICE OF TORQUE
AND SPEED**

ADAPTED CONNECTION

NX and EX Associations - DIGIVEX / 230V

Motor	M ₀ (N.m)	I ₀ (A)	M _N (N.m)	I _N (A)	N _{MAX} (tr/min)	M _{MAX} (N.m)	I _{MAX} (A)	DIGIVEX rating
NX SERVO MOTORS								
NX110EAP	0.45	1.4	0.33	1.0	6000	1.1	3.5	2/4
NX205EAV	0.45	1.4	0.37	1.2	5000	0.9	2.8	2/4
NX205EAS	0.45	1.9	0.29	1.3	7500	0.9	4	2/4
NX210EAT	1	1.9	0.80	1.5	4000	2.1	4.0	2/4
NX210EAP	1	2.8	0.61	1.8	6000	2.4	7.0	4/8
NX310EAP	2	2.0	1.9	1.9	2300	3.9	4.0	2/4
NX310EAK	2	3.5	1.7	2.9	4000	4.3	8.0	4/8
NX420EAP	4	4.0	3.8	3.8	2300	7.7	8.0	4/8
NX420EAJ	4	6.9	3.4	5.8	4000	8.2	15.0	7.5/15
NX430EAJ	5.5	7.4	4.7	6.3	3200	10.7	15.0	7.5/15
NX430EAF	5.5	9.4	4.3	7.4	4000	15.0	28.3	15/30
NX620EAR	8	7.5	7.4	7.0	2200	15.9	15.0	7.5/15
NX620EAJ	8	13.9	6.1	10.8	4000	16.9	30.0	15/30
NX630EAR	12	8.0	11.5	7.8	1450	22.6	15.0	7.5/15
NX630EAK	12	15.0	10.2	12.9	2800	23.9	30.0	15/30
NX630EAG	12	21.1	8.3	15.1	4000	28.8	53.1	30/60
NX820EAL	16	24.8	13.2	20.9	3600	35.3	60.0	30/60
NX840EAJ	28	26.7	22.9	22.2	2200	59.7	60.0	30/60
NX860EAD	41	46.7	27.4	32.1	2600	84.8	100.0	60/100
NX860VAG ⁽¹⁾	64	55.4	54.4	47.1	2000	107	100.0	60/100

EX SERVO MOTORS FOR EXPLOSIVE ATMOSPHERE

EX310EAP	1.7	1.7	1.7	1.7	2300	3.9	4	2/4
EX310EAK	1.7	3.1	1.6	2.8	4000	3.5	8	4/8
EX420EAP ⁽²⁾	3.5	3.5	3.2	3.2	2300	7.8	8	4/8
EX420EAJ ⁽²⁾	3.5	6.0	2.7	4.7	4000	8.3	15	7.5/15
EX430EAJ ⁽²⁾	4.8	6.5	3.7	5.1	3200	10.8	15	7.5/15
EX430EAF ⁽²⁾	4.8	8.2	3.3	5.7	4000	11.6	20.5	15/30
EX620EAO	7	7.4	5.5	6.3	2500	13.9	15	7.5/15
EX630EAI	10.4	14.2	7.2	10.3	3000	22.5	30	15/30
EX820EAR ⁽²⁾	14	13.5	11.5	11.3	2200	29.5	30	15/30
EX820EAL ⁽²⁾	14	21.7	8.6	13.8	3600	32.5	54	30/60
EX840EAJ ⁽²⁾	24.5	23.4	15.2	15	2200	58.4	59	30/60
EX860EAD ⁽²⁾	35	39.9	12	14.9	2600	84.5	100	60/100

NX and EX Associations - DIGIVEX / 400V

Motor	M ₀ (N.m)	I ₀ (A)	M _N (N.m)	I _N (A)	N _{MAX} (tr/min)	M _{MAX} (N.m)	I _{MAX} (A)	DIGIVEX rating
NX SERVO MOTORS								
NX205EAV	0.45	1.4	0.29	1.0	7500	1	3.2	2/4
NX210EAT	1	1.9	0.61	1.2	6000	2.1	4.0	2/4
NX310EAP	2	2.0	1.7	1.7	4000	3.9	4.0	2/4
NX420EAV	4	2.0	3.8	1.9	2000	7.7	4.0	2/4
NX420EAP	4	4.0	3.4	3.4	4000	7.7	8.0	4/8
NX430EAV	5.5	2.0	5.4	2.0	1000	10.6	4.0	2/4
NX430EAP	5.5	4.0	4.8	3.5	3000	10.6	8.0	4/8
NX430EAL	5.5	5.4	4.3	4.2	4000	15	16.0	8/16
NX620EAV	8	4.0	7.5	3.8	2000	16	8.0	4/8
NX620EAR	8	7.5	6.2	5.9	3900	16.9	16.0	8/16
NX620EAJ	8	13.9	5.6	7.2	4500	17.9	32.0	16/32
NX630EAV	12	4.0	11.6	2.7	1350	24.1	8.0	4/8
NX630EAR	12	8.0	10.3	7.0	2700	23.9	16.0	8/16
NX630EAN	12	12.0	8.3	8.6	4000	28.8	30.2	16/32
NX820EAX	16	7.3	14.7	6.8	1900	32.7	16.0	8/16
NX820EAR	16	15.5	12.9	12.8	3900	31.1	32.0	16/32
NX840EAQ	28	14.3	23.2	12.0	2100	59.7	32.0	16/32
NX840EAK	28	23.8	18.5	16.3	3500	65.3	59.4	32/64
NX860EAJ	41	26.3	27.4	18.1	2600	94.4	64.0	32/64
NX860VAJ ⁽¹⁾	64	41.5	50.5	32.8	2600	113	80.0	50/80

EX SERVO MOTORS FOR EXPLOSIVE ATMOSPHERE

EX310EAP	1.7	1.7	1.5	1.6	4000	3.9	4	2/4
EX420EAV ⁽²⁾	3.5	1.75	3.2	1.6	2000	7.7	4	2/4
EX420EAP ⁽²⁾	3.5	3.5	2.7	2.7	4000	7.8	8	4/8
EX430EAP ⁽²⁾	4.8	3.5	3.9	2.8	3000	10.7	8	4/8
EX430EAL ⁽²⁾	4.8	4.7	3.3	3.3	4000	11.6	11.7	8/16
EX620EAO	7	7.8	3.1	3.9	4300	14.7	16	8/16
EX630EAY	10.4	7.8	7.4	5.8	2900	21.8	16	8/16
EX630EAN	10.4	10.6	5.2	5.8	4000	26.0	26.5	16/32
EX820EAW ⁽²⁾	14	7.9	11.5	6.6	2200	27.3	16	8/16
EX820EAR ⁽²⁾	14	13.5	8.6	8.6	3600	31.1	32	16/32
EX840EAQ ⁽²⁾	24.5	12.5	15.9	8.3	2100	58.4	31.2	16/32
EX840EAK ⁽²⁾	24.5	20.8	5	4.9	3300	58.4	52	32/64
EX860EAJ ⁽²⁾	35	22.4	12	8.4	2600	84.5	56.1	32/64

⁽¹⁾ Ventilated motor - ⁽²⁾ To be released soon

BRUSHLESS NX

0.45 to 64N.m

The NX series is the new brushless servo motor range.

The NX series brushless servo motors are characterized by a 10-pole innovative design for highest quality of motion, improved torque density and a compact and robust design.

With a large choice of torque and speed and an economical design, the NX series is the ideal solution for servo application.



230V AND 400V POWER SUPPLY

MOTION QUALITY AND HIGH DYNAMIC CHARACTERISTICS

ROBUST AND COMPACT CONSTRUCTION

ROTOR WITH CONCENTRATED-FLUX RARE EARTH MAGNETS

10-POLE DESIGN

RESOLVER AS STANDARD

PROTECTION

NX1 TO NX8 : IP64, OPTION IP65

CLASS F INSULATION

OUTPUT CABLES ON NX1 AND NX2

ADJUSTABLE CONNECTORS ON NX2 TO NX8

CE, UL RECOGNISED (NX3 TO NX6)

* NX8V : IP44

NX Series

Motor	Torque M_0 (N.m)	Max Speed (rpm)		Inertia ($\text{kg.m}^2 \cdot 10^{-5}$)
		230V	400V	
NX110EAP	0.45	6000	-	1.3
NX205EAV	0.45	5000	7500	2.1
NX205EAS	0.45	7500	-	2.1
NX210EAT	1	4000	6000	3.8
NX210EAP	1	6000	-	3.8
NX310EAP	2	2300	4000	7.9
NX310EAK	2	4000	-	7.9
NX420EAV	4	-	2000	29
NX420EAP	4	2300	4000	29
NX420EAJ	4	4000	-	29
NX430EAJ	5.5	3200	-	42.6
NX430EAF	5.5	4000	-	42.6
NX430EAV	5.5	-	1000	42.6
NX430EAP	5.5	-	3000	42.6
NX430EAL	5.5	-	4000	42.6
NX620EAV	8	-	2000	98
NX620EAR	8	2200	3900	98
NX620EAJ	8	4000	4500	98
NX630EAV	12	-	1350	147
NX630EAR	12	1450	2700	147
NX630EAK	12	2800	-	147
NX630EAG	12	4000	-	147
NX630EAN	12	-	4000	147
NX820EAL	16	3600	-	320
NX820EAX	16	-	1900	320
NX820EAR	16	-	3900	320
NX840EAJ	28	2200	-	620
NX840EAQ	28	-	2100	620
NX840EAK	28	-	3500	620
NX860EAD	41	2600	-	920
NX860EAJ	41	-	2600	920
NX860VAG ⁽¹⁾	64	2000	-	920
NX860VAJ ⁽¹⁾	64	-	2600	920

⁽¹⁾ Ventilated motor

CUSTOM SOLUTION

WINDING, SHAFT, FLANGE...

INCREMENTAL, ABSOLUTE, HIPERFACE ENCODER OPTION, ...

ATEX 94/9/CE FLAMEPROOF ENCLOSURE VERSION

SERVO MOTOR KIT VERSION

SERVO MOTORS

NX1 and NX2 Dimensions (cable version)

Motor	N (mm)	D (mm)	E (mm)	T (mm)	P (mm)	S (mm)	M (mm)	No brake		With brake		Fr* (daN)	Fa* (daN)
								Weight (kg)	L (mm)	Weight (kg)	L (mm)		
NX110	30	9	25	2.5	42.5	3.2	50	0.8	110	1	140	15	6.9
NX205	40	11	25	2.5	56.5	5.5	63	0.8	102	1.1	136	28	15.5
NX210	40	11	25	2.5	56.5	5.5	63	1.3	122	1.6	156	30	16.7

*Fr and Fa not cumulative - At 1500 rpm for a bearing service life of 20000 hours

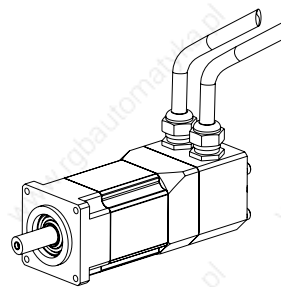
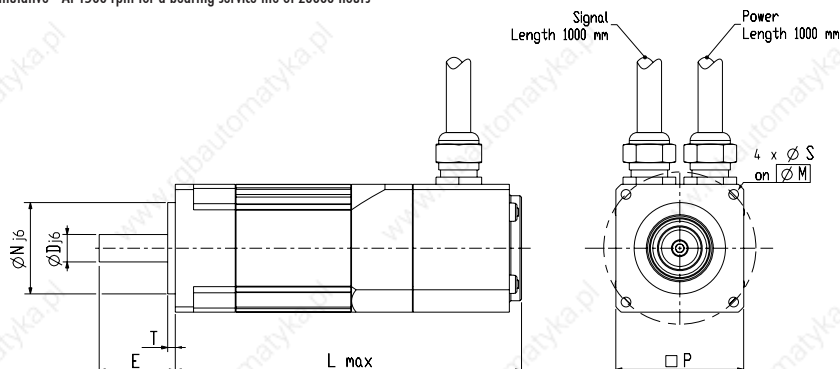

NX2 Dimensions (connector version)

Motor	N (mm)	D (mm)	E (mm)	T (mm)	P (mm)	S (mm)	M (mm)	No brake		With brake		Fr* (daN)	Fa* (daN)
								Weight (kg)	L (mm)	Weight (kg)	L (mm)		
NX205	40	11	25	2.5	56.5	5.5	63	0.8	102	1.1	136	28	15.5
NX210	40	11	25	2.5	56.5	5.5	63	1.3	122	1.6	156	30	16.7

*Fr and Fa not cumulative - At 1500 rpm for a bearing service life of 20000 hours

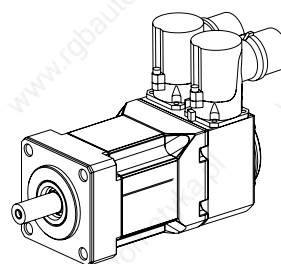
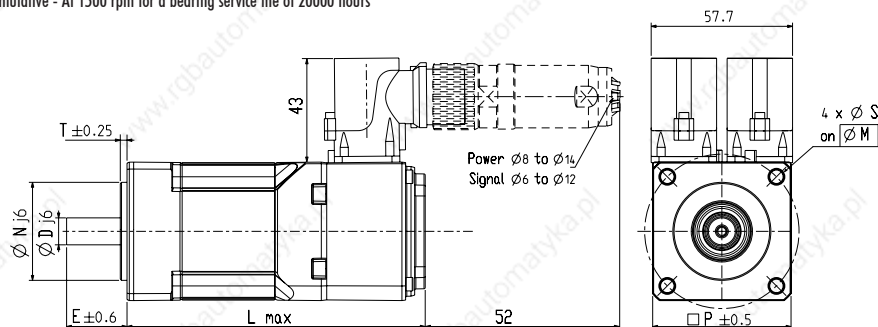

NX3, NX4 and NX6 dimensions

Motor	N (mm)	D (mm)	E (mm)	T (mm)	P (mm)	S (mm)	M (mm)	No brake		With brake		Fr* (daN)	Fa* (daN)
								Weight (kg)	L (mm)	Weight (kg)	L (mm)		
NX310	60	11	23	2.5	71	5.5	75-80	2	146	2.4	194	36	20
NX420	80	19	40	3	91.5	7	100	3.7	175	4.5	226	72	24
NX430	80	19	40	3	91.5	7	100	4.6	200	5.4	251	82	24
NX620	110	24	50	3.5	121	9	130	6.9	181	8	236	82	52
NX630	110	24	50	3.5	121	9	130	8.8	210	10	265	86	54

*Fr and Fa not cumulative - At 1500 rpm for a bearing service life of 20000 hours

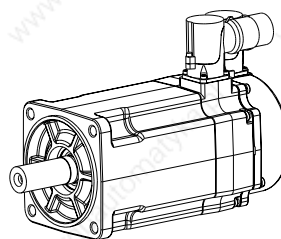
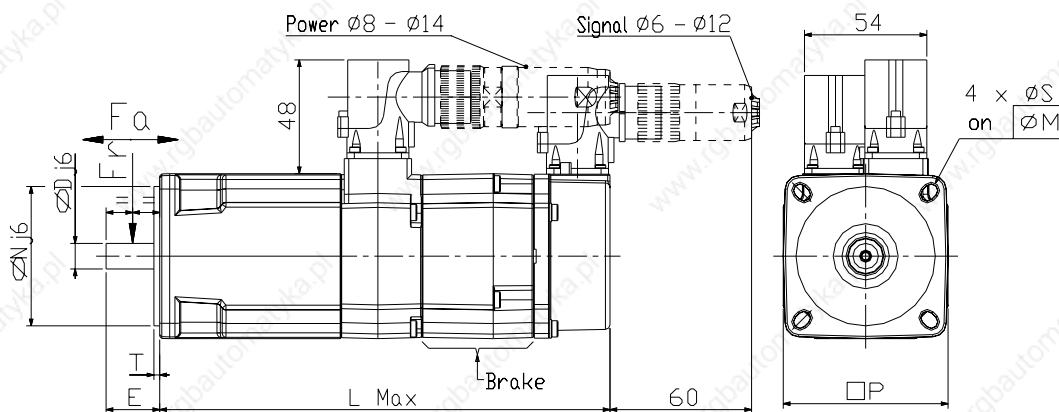

SERVO MOTORS

NX8 Dimensions

Motor	No brake		With brake		Fr*	Fa*
	Weight (kg)	L (mm)	Weight (kg)	L (mm)		
NX820	13	200	16.5	266	151	28
NX840	20	260	23.5	326	165	33
NX860	27	320	30.5	386	172	37

*Fr and Fa not cumulative - At 1500 rpm for a bearing service life of 20000 hours

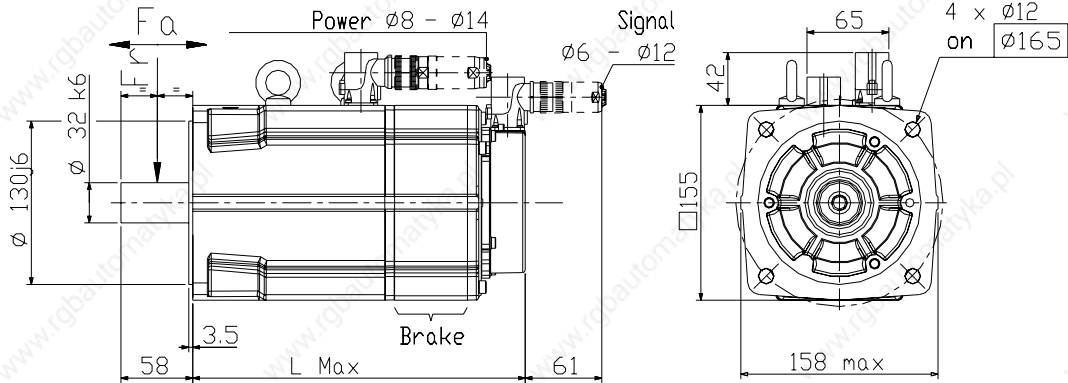
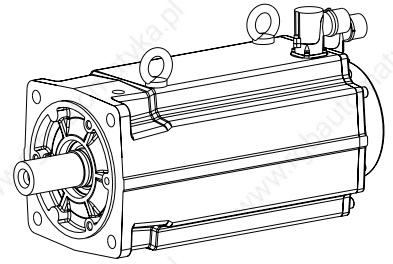

NX8 dimensions (Ventilated version)

Motor	No brake		With brake		Fr*	Fa*
	Weight (kg)	L (mm)	Weight (kg)	L (mm)		
NX860V	30.5	424	34	490	172	37

*Fr and Fa not cumulative - At 1500 rpm for a bearing service life of 20000 hours

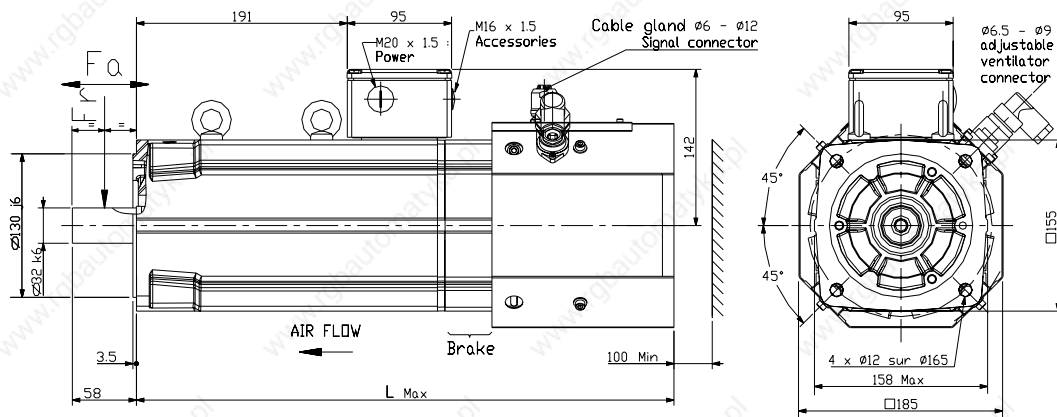
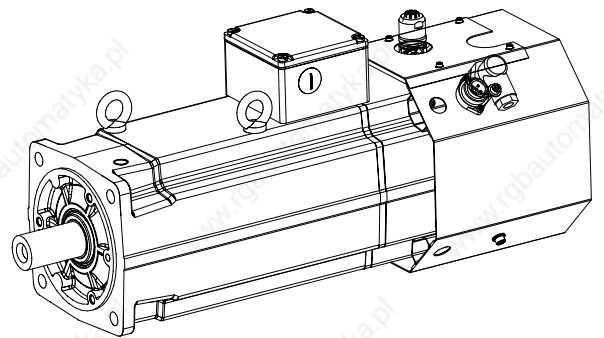

NX SERIES : A ROBUST AND SECURE CONSTRUCTION FOR HIGH LEVEL PERFORMANCES

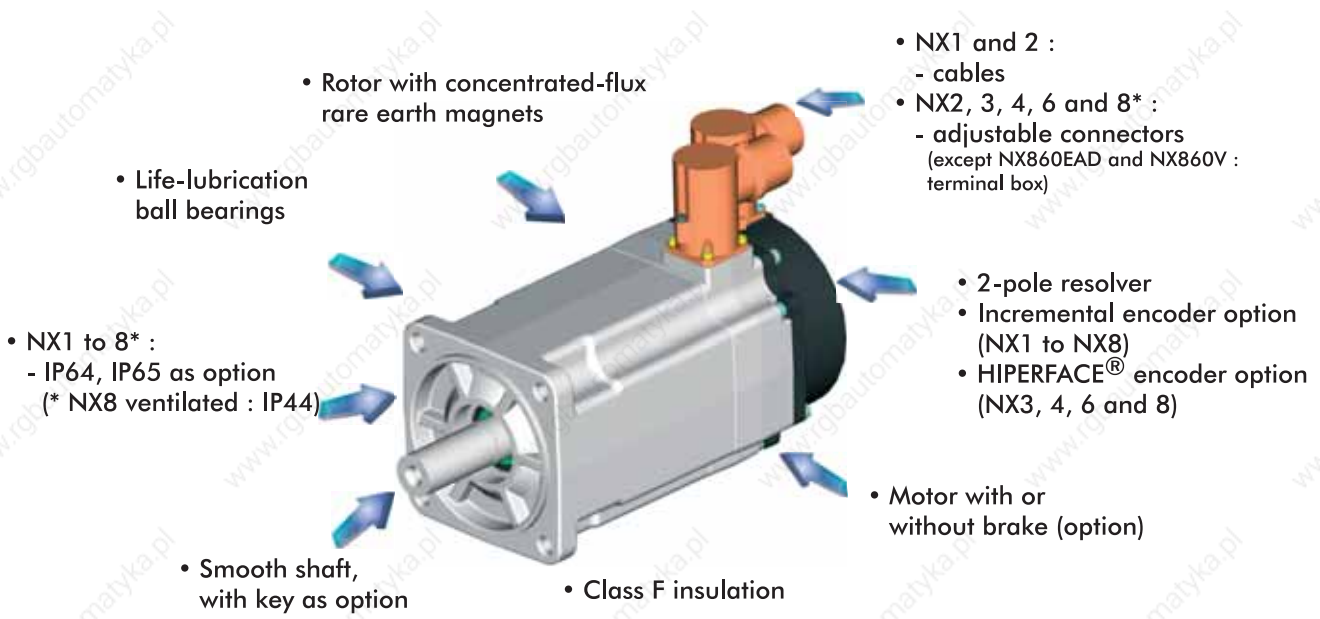

(1) : NX3 to NX6



NX SERVO MOTOR CODIFICATION

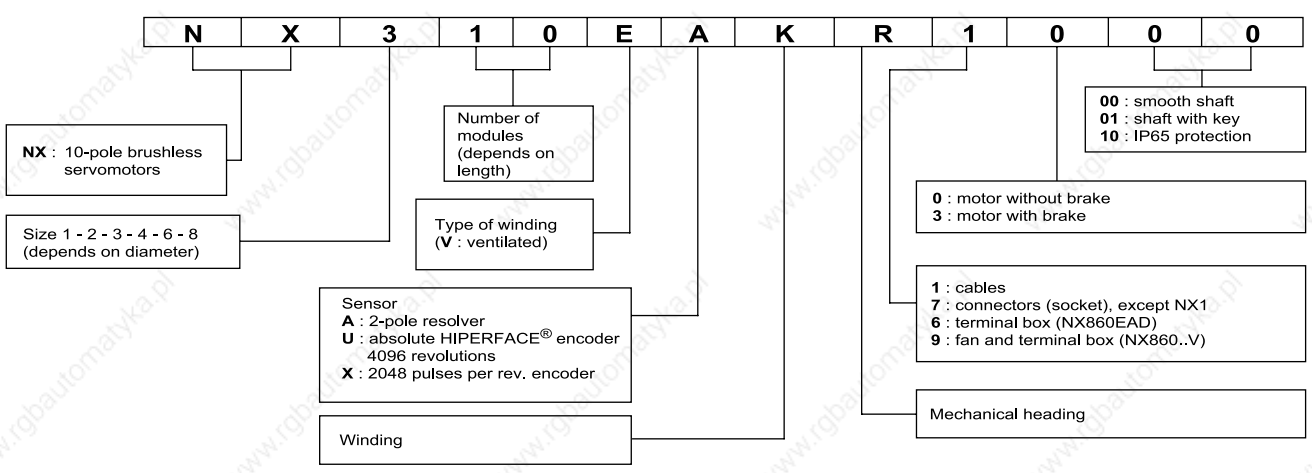

HIPERFACE® ENCODER OPTION For NX size 3 to 8

The HIPERFACE® encoder is a mixture of an absolute encoder (single or multiturn) and of an incremental encoder of sine/cosine type.

Absolute position is sent via an RS485 connection at power-on; then position is incrementally counted from this absolute position by using sine/cosine signals.



SinCos HIPERFACE® encoder :

- Absolute position within 4096 revolutions
- 15 bits absolute position resolution on one rev.
- 1024 sine / cosine signals per rev.

With 637f Drive:

- Incremental encoder resolution : 16 bits (65536 points/rev)
- Maximum speed 6000 rpm
- Speed ripple : $\approx 0.3\%$ at 4000 rpm
- Maximum position error : ± 45 arc sec

MOUNTING OF STEGMANN SRM50 HIPERFACE® ENCODER ON NX3 TO NX8

**ABSOLUTE POSITION WITHIN
4096 REVOLUTIONS**

**ABSOLUTE POSITION RESOLUTION :
15 BITS PER REVOLUTION**

**SINE/COSINE SIGNALS :
1024 CYCLES PER REVOLUTION**

**ON NX3 TO NX8 MOTORS, SAME
TORQUE, SPEED AND INERTIA AS FOR THE
RESOLVER MOUNTING**

HIPERFACE® ENCODER PRINCIPLE

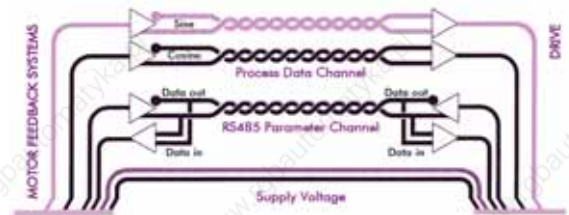

Extract from STEGMANN documentation

RS485 channel : parameter channel

- Encoder parameter setting
- Initial absolute position sent at power-on
- Sine / cosine : process data channel
- Analog sine / cosine signals with 1024 cycles per rev.
- Conversion of sine / cosine signals to incremental signals done inside drive

NX DIMENSIONS WITH HIPERFACE® ENCODER

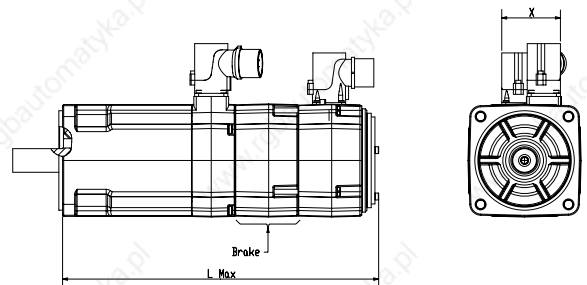

NX dimensions with hiperface

Motor	L		X (mm)
	No brake (mm)	With brake (mm)	
NX310	173	199	44
NX420	205	256	47.5
NX430	230	281	47.5
NX620	214	268	55
NX630	243	297	55
NX820	236	282	65
NX840	296	342	65
NX860	356	402	65

Other dimensions unchanged compared to resolver mounting

MECHANICAL AND ELECTRICAL ADAPTATIONS

Based on standard offer

As a servo motor specialist, SSD Drives Parvex has developed its organization and know-how to adapt its standard motors for OEM and machine builders :

- **Mechanical adaptations** : shaft, flange, nema flange, housing, ...
- **Electrical adaptations** : speed, speed/torque, voltage, winding, ...
- **Specific sensor mounting** : Endat, Hiperface, incremental encoder, absolute encoder, hall effect sensor, ...
- **Motor accessories** like gearboxes, cables, connectors, ...

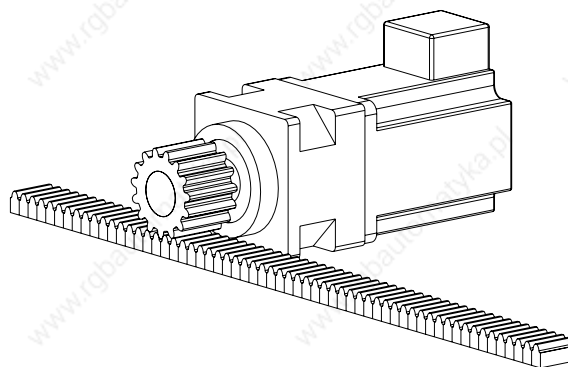

ELECTRICAL ADAPTATIONS

MECHANICAL ADAPTATIONS

SPECIAL WINDINGS

SPECIFIC FEEDBACK SENSORS

GEARBOXES

BRUSHLESS EX ATEX APPROVED

new

1.75 to 35 Nm*

EX servo motors are "d" flameproof apparatus designed to operate in potentially explosive atmosphere according to 94/9/CE "New Approach" ATEX directive.

Based on an innovative 10-pole design, they are characterised by an excellent motion quality for a high torque density.

In combination with GA gearboxes, they offer a complete, robust and powerful ATEX geared motor solution.



"D" FLAMEPROOF EQUIPMENT IN ACCORDANCE WITH ATEX 94/9/CE DIRECTIVE*

ATEX GEARED MOTOR SOLUTION IN COMBINATION WITH GA GEARBOX

230V OR 400V POWER SUPPLY

INTEGRATED THERMO-CONTACT AND THERMO-FUSE FOR THERMAL PROTECTION

BRAKE OPTION

* : 14 to 35 Nm, available soon

EX Series - 230V power supply

Motor	M ₀ (Nm)	N _{MAX} (tr/min)	Inertia (kg.m ² .10 ⁻³)	Weight (kg)
EX310EAP	1.75	2300	7.9	2.7
EX310EAK	1.75	4000	7.9	2.7
EX420EAP ⁽¹⁾	3.5	2300	29	5
EX420EAJ ⁽¹⁾	3.5	4000	29	5
EX430EAJ ⁽¹⁾	4.8	3200	43	6
EX430EAF ⁽¹⁾	4.8	4000	43	6
EX620EAO	6.6	2500	98	9.1
EX630EAI	10.4	3000	147	11
EX820EAR ⁽¹⁾	14	2200	320	24
EX820EAL ⁽¹⁾	14	3600	320	24
EX840EAJ ⁽¹⁾	24.5	2200	620	32
EX860EAD ⁽¹⁾	35	2600	920	40

EX Series - 400V power supply

Motor	M ₀ (Nm)	N _{MAX} (tr/min)	Inertia (kg.m ² .10 ⁻³)	Weight (kg)
EX310EAP	1.75	4000	7.9	2.7
EX420EAV ⁽¹⁾	3.5	2000	29	5
EX420EAP ⁽¹⁾	3.5	4000	29	5
EX430EAP ⁽¹⁾	4.8	3000	43	6
EX430EAL ⁽¹⁾	4.8	4000	43	6
EX620EAO	7	4300	98	9.1
EX630EAY	10.4	2900	147	11
EX630EAN	10.4	4000	147	11
EX820EAV ⁽¹⁾	14	2200	320	24
EX820EAR ⁽¹⁾	14	3600	320	24
EX840EAV ⁽¹⁾	24.5	2100	620	32
EX840EAK ⁽¹⁾	24.5	3300	620	32
EX860EAJ ⁽¹⁾	35	2600	920	40

⁽¹⁾ : available soon

Mechanical associations

GA Gearboxes - EX Servo motors

Motor	GA gearbox size		
	Torque, inertia	03 04	06
EX310 1.75 ; 7.9	GA3N...R03.. r = 5 or 25		
EX420 3.5 ; 29		GA4N...R04.. r = 5 or 25	
EX430 4.8 ; 42.6		GA4N...R04.. r = 5 or 25	
EX620 7 ; 98			GA6N...R06.. r = 5 or 25
EX630 10.4 ; 147			GA6N...R06.. r = 5 or 25

r = gearbox ratio, torque (N.m) and Inertia (10⁻³.kgm²)

Gearbox selection, please refer to example on page 26.

IMPORTANT : please confirm the operating limit of the association selected above with our technical service centre.

EX SERVO MOTORS TECHNICAL SPECIFICATIONS

Classification :

- II 2G EEx d IIB T4 (Gas)
- ou II 2GD EEx d IIB T4 IP65 T135°C (Gas & Dust)
- Normes EN 50014, EN 50018 et EN 50281-1-1

Protection :

thermo-switches and thermo-fuse inside winding for over-temperature protection

Connection :

through flameproof cable glands for resolver and power (no pre-equipped cables)

Option :

- With or without key
- With or without brake

GA GEARBOXES TECHNICAL SPECIFICATIONS

Classification :

- Standard EN 13463-1

SERVO MOTORS

EX3 DIMENSIONS

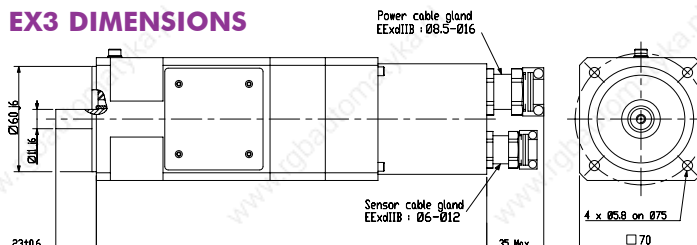

EX3 Dimensions (mm)

Motor	L	
	No brake	With brake
EX310	225	255

EX4 DIMENSIONS

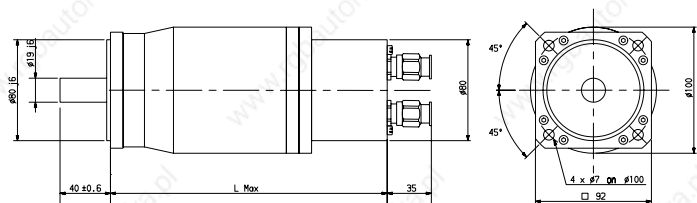

EX4 Dimensions (mm)

Motor	L	
	No brake	With brake
EX420	265	290
EX430	290	315

EX6 AND EX8 DIMENSIONS

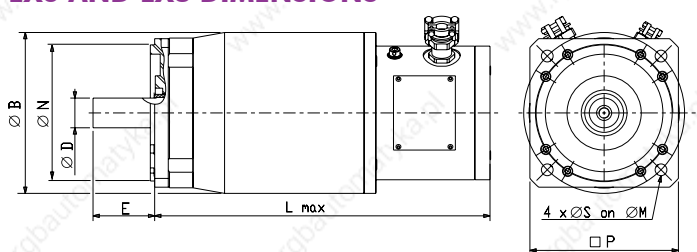

EX6 and EX8 Dimensions (mm)

Motor	N	D	E	B	P	S	M	L	
								No brake	With brake
EX620	110	24	50	130	120	8.4	130	275	300
EX630	110	24	50	130	120	8.4	130	300	325
EX820	130	32	58	160	150	12	165	320	360
EX840	130	32	58	160	150	12	165	380	420
EX860	130	32	58	160	150	12	165	440	480

GA3 GEARBOX DIMENSIONS

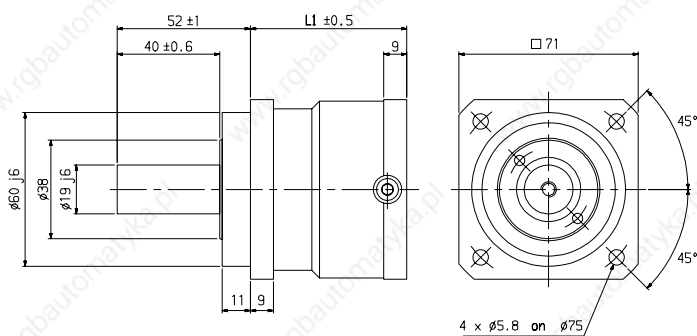

GA3 Dimensions

Motor	r	L1	Weight
GA3	5	61	1.6
GA3	25	97	2.2

Dimensions in mm, weight in kg

GA4 AND GA6 GEARBOXES DIMENSIONS

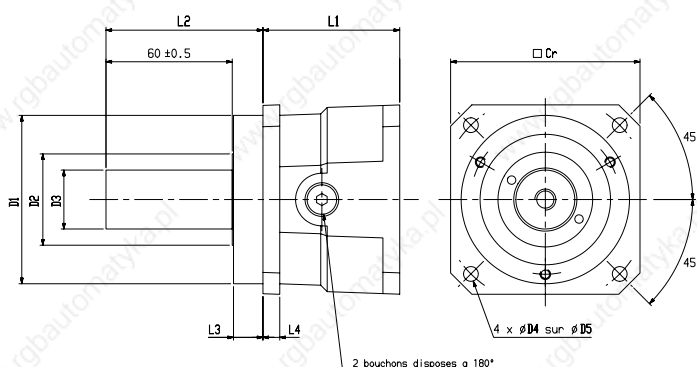

GA4 and GA6 Dimensions

Gearbox	r	L1	L2	D1	D2	D3	D4	D5	□Cr	Weight
GA4	5	64.8	74.6	80j6	43	28j6	7	100	91	3.2
GA4	25	106.8	74.6	80j6	43	28j6	7	100	91	5.2
GA6	5	74.8	78.3	110j6	53	32k6	9	130	115	6.2
GA6	25	117.8	78.3	110j6	53	32k6	9	130	115	9.4

Dimensions in mm, weight in kg

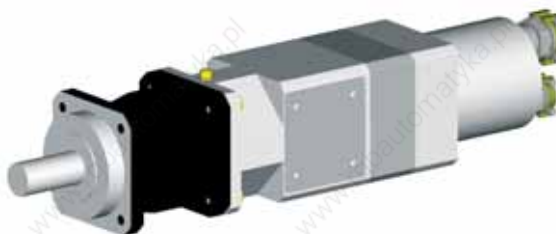

CUSTOM OEM SOLUTIONS

Servo motor kits : an innovative and customised solution for OEM applications

Servo motor kits are a unique customised solution to your most demanding applications, where **cost**, **space**, **rigidity** and **reliability** are your equally important concerns.

That innovative offering is based on the NX technology. The motor components are supplied instead of a standard motor.

The **rotor**, the **stator**, the **sensor** and **all relevant mechanical adaptations** are **designed for optimum integration** at the heart of your mechanical systems.

That solution stems from a global approach backed by :

- a **sales network** capable of understanding your specific needs
- a **highly qualified technical staff** to offer assistance throughout the specification stage
- a **flexible industrial organisation**

As a result, the size and cost constraints are handled with the maximum care.

Other benefits include the following :

- Accuracy, reliability and robustness
- Mechanical compactness and reduced weight
- Direct drive : accurate and robust mechanics
- Complete and optimised solution including sensor



Ball screw direct coupling example

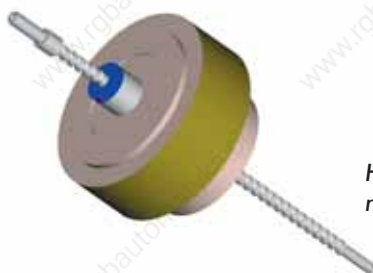

Hollow shaft motor example



Servo motor kits can be designed for applications in the following range :

- Torque from 0.4 to 72 Nm
- Speed up to 15000 rpm

On top of mechanical customisations (iron length, frame, ...), many design variations are available :

- Custom windings
- Air or water cooling
- Hall effect sensor, resolver, high resolution sensor, optical encoder

INTEGRATION ASSISTANCE

CUSTOMISED SOLUTION

REDUCED COST

MECHANICAL COMPACTNESS

REDUCED WEIGHT

ACCURATE AND ROBUST MECHANICS

TORQUE FROM 0.4 TO 72 NM

SERVO MOTORS

BRUSHLESS LS - HS

7 to 31N.m

The LS-HS brushless servo motors short construction can offer the solution when space available for motor is reduced or when the load inertia is high.

Developed with a rotor using ferrite magnets, they range from 7 to 31 Nm.



LS - 230V power supply

Motor	M ₀ (N.m)	I ₀ (A)	M _N (N.m)	N _{MAX} (rpm)	M _{MAX} (N.m)	Inertia J (kgm ² .10 ⁻³)	DIGIVEX Drive Rating
LS810EX	7	7.18	6.7	2000	13.2	200	7.5/15
LS810ER	7	13.9	6.1	4000	13.5	200	15/30
LS820EQ	14	14.8	13.1	2100	25.7	350	15/30
LS820EJ	14	27.8	11.6	4000	27	350	30/60
LS910EW	15	14.3	13.6	1800	28.1	680	15/30
LS910EM	15	27.9	11.4	3600	28.6	680	30/60
LS920EM	31	27.4	28	1800	59.5	1200	30/60
LS920EH	31	52.5	22.4	3400	53.2	1200	60/100

HS - 400V power supply

Motor	M ₀ (N.m)	I ₀ (A)	M _N (N.m)	N _{max} (rpm)	M _{max} (N.m)	Inertia J (kgm ² .10 ⁻³)	DIGIVEX Drive Rating
HS810EZ	7	4	6.6	2200	12.7	200	4/8
HS810EY	7	6.42	6.3	3600	13.6	200	8/16
HS810EW	7	8	6	4400	12.7	200	8/16
HS820EV	14	7.76	13	2200	26.1	350	8/16
HS820EQ	14	14.8	11.3	4200	27.1	350	16/32
HS910EX	15	7.05	13.7	1700	29.1	680	8/16
HS910EW	15	14.3	11.4	3600	29.1	680	16/32
HS920EW	31	7.51	29.9	900	58.3	1200	8/16
HS920ET	31	15	27.8	1900	58.3	1200	16/32
HS920EL	31	30	20.5	3800	58.3	1200	32/64

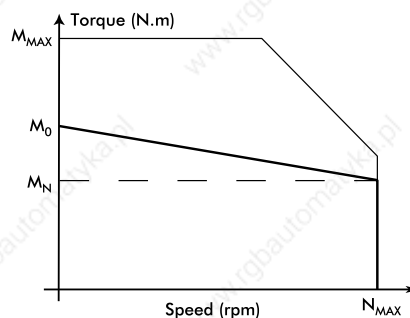
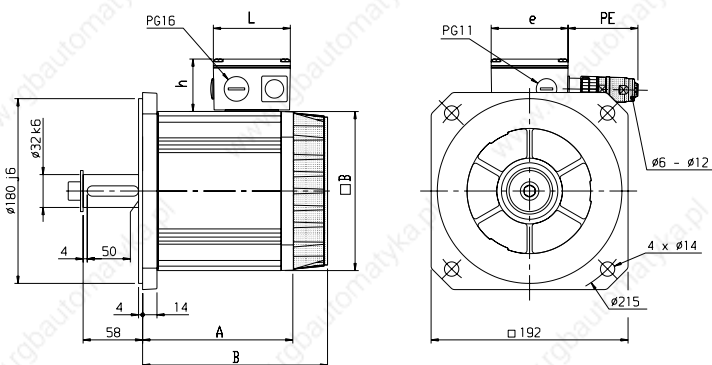

LS-HS dimensions

Motor	L (mm)	h (mm)	e (mm)	PE (mm)	□B (mm)	A ⁽¹⁾ (mm)	B ⁽²⁾ (mm)	Weight (kg)	Fr* (daN)	Fa* (daN)
LS810	76	51	76	91	155	144	182	10.4	65	45
LS820	76	51	76	91	155	185	223	14.6	70	50
LS910	95	65	95	91	192	166	200	17	105	40
LS920	95	65	95	91	192	216	259	25.2	120	40
HS810	76	51	76	91	155	144	182	10.4	65	45
HS820	76	51	76	91	155	185	223	14.6	70	50
HS910	95	65	95	91	192	166	200	17	105	40
HS920	95	65	95	91	192	216	259	25.2	120	40

(1) : no brake (2) : with brake
* Fr and Fa not cumulative ; at 3000 rpm

**SHORT CONSTRUCTION
230V AND 400 POWER SUPPLY**

FERRITE MAGNETS

**RESOLVER CONNECTOR AND
TERMINAL BOX FOR POWER**

BRAKE OPTION

CLASS F INSULATION

**IP64 PROTECTION,
IP65 AS OPTION**

BRUSHLESS LX - HX

6.7 to 320N.m

LX-HX brushless servo motors series are characterised by a very large torque range and by the highest torque to inertia ratio. They are particularly adapted to demanding servo applications needing very high dynamic characteristics.



- LOW INERTIA CONSTRUCTION
- 230V AND 400V POWER SUPPLY
- HIGH DYNAMIC CHARACTERISTICS
- RARE EARTH MAGNETS
- RESOLVER CONNECTOR AND TERMINAL BOX FOR POWER
- BRAKE OPTION
- CLASS F INSULATION
- IP64 PROTECTION, IP65 AS OPTION

LX - 230V power supply

Motor	M_0 (N.m)	I_0 (A)	M_N (N.m)	N_{MAX} (rpm)	M_{MAX} (N.m)	Inertia J ($kgm^2 \cdot 10^{-3}$)	DIGIVEX Drive Rating
LX440CL	6.7	7	6.1	2200	13.6	34	7.5/15
LX440CC	6.7	14.7	5.2	4700	13.0	34	15/30
LX440CB	6.7	19	4.6	6000	15.5	34	30/60
LX820DH	19	27.6	16.1	2800	38.4	230	30/60
LX820DF	19	36.8	13.9	3800	42.6	230	60/100
LX820VK ⁽¹⁾	28	29.8	26.7	2000	48	230	30/60
LX820VF ⁽¹⁾	28	54.6	22.8	3800	45.1	230	60/100
LX840DG	38	29.6	32.5	1600	72.8	420	30/60
LX840DE	38	41.4	28.4	2200	83.8	420	60/100
LX840VE ⁽¹⁾	54	59.7	46.8	2200	83.8	420	60/100

⁽¹⁾ Ventilated motor

HX - 400V power supply

Motor	M_0 (N.m)	I_0 (A)	M_N (N.m)	N_{MAX} (rpm)	M_{MAX} (N.m)	Inertia J ($kgm^2 \cdot 10^{-3}$)	DIGIVEX Drive Rating
HX440CW	6.7	3.5	6.2	2100	14.4	34	4/8
HX440CR	6.7	4.9	5.9	3000	15.5	34	8/16
HX440CK	6.7	7.4	5.3	4500	13.7	34	8/16
HX440CH	6.7	9.5	4.7	5800	15.5	34	16/32
HX820DT	19	7.9	18.1	1500	36.4	230	8/16
HX820DN	19	15.8	15.5	3100	36.4	230	16/32
HX820DJ	19	22.1	12.8	4200	42.5	230	32/64
HX820VK ⁽¹⁾	28	29.8	22.2	4000	50	230	32/64
HX820VH ⁽¹⁾	28	41	18.7	5000	47	230	50/80
HX840DN	38	14.8	33.1	1500	76.8	420	16/32
HX840DH	38	25.9	25	2600	85.3	420	32/64
HX840VJ ⁽¹⁾	55	30.5	47.4	2100	100.5	420	32/64
HX840VG ⁽¹⁾	55	43.5	40.6	3100	91.3	420	50/80
HX840VH ⁽¹⁾	55	43.5	40.6	3100	112.9	420	100/120
HXA30V ⁽¹⁾	170	98.8	123.9	2000	190.7	2700	100/120
HXA40V ⁽¹⁾	228	99.6	185.9	1400	254	3500	100/120
HXA40VG ⁽¹⁾	230	130	170.9	1900	250	3500	150
HXA40VE ⁽¹⁾	230	182	147.7	2700	243	3500	200
HXA50VF ⁽¹⁾	280	146	213	1800	284	4300	150
HXA50VE ⁽¹⁾	280	175	204	2150	303	4300	200
HXA60VF ⁽¹⁾	320	136	262	1450	339	5100	150
HXA60VD ⁽¹⁾	315	199	206	2200	315	5100	200

⁽¹⁾ Ventilated motor

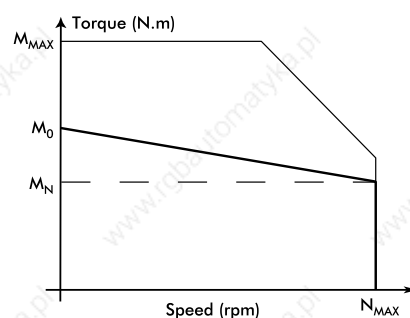

LX4 - HX4 dimensions

Motor	No brake		With brake		Fr*	Fa*
	A (mm)	B (mm)	Weight (kg)	Weight (kg)		
LX440	214	264	6.4	45	20	20
HX440	214	264	6.4	45	20	20

* Fr and Fa not cumulative ; at 3000 rpm

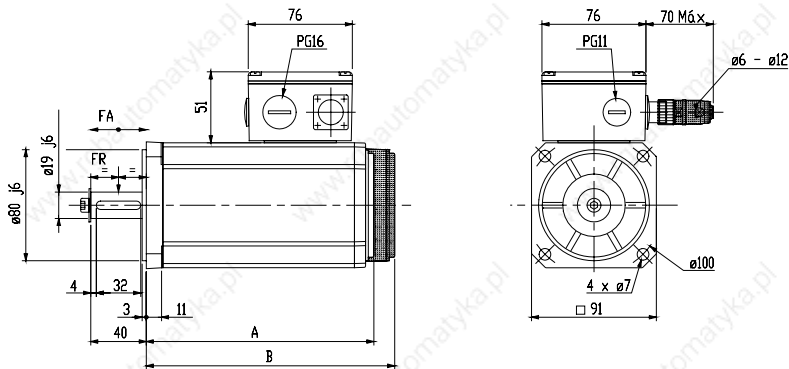

LX8 - HX8 dimensions

Motor	No brake		With brake		Fr*	Fa*
	A (mm)	B (mm)	Weight (kg)	Weight (kg)		
LX820	238	305	17	250	35	35
LX840	322	389	26	250	35	35
HX820	238	305	17	250	35	35
HX840	322	389	26	250	35	35

* Fr and Fa not cumulative ; at 3000 rpm

Power connector as option

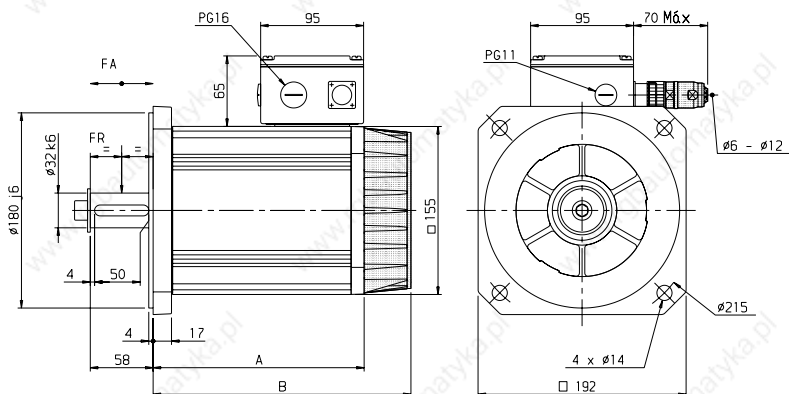

LX8V - HX8V dimensions

Motor	No brake		With brake		Fr*	Fa*
	A (mm)	B (mm)	Weight (kg)	Weight (kg)		
LX820V	333	401	23	250	35	35
LX840V	417	485	32	250	35	35
HX820V	333	401	23	250	35	35
HX840V	417	485	32	250	35	35

* Fr and Fa not cumulative ; at 3000 rpm

Power connector as option

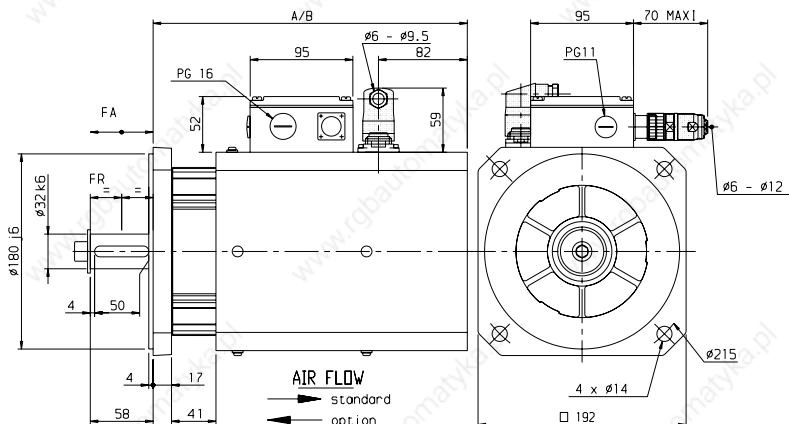

HXA dimensions

Motor	No brake		With brake		Fr*	Fa*
	E (mm)	L (mm)	E (mm)	L (mm)		
HXA30V	271	582	271	582	100	530
HXA40V	349	660	349	660	110	550
HXA50V	349	660	391	702	120	550
HXA60V	391	702	-	-	135	550

* Fr and Fa not cumulative ; at 3000 rpm

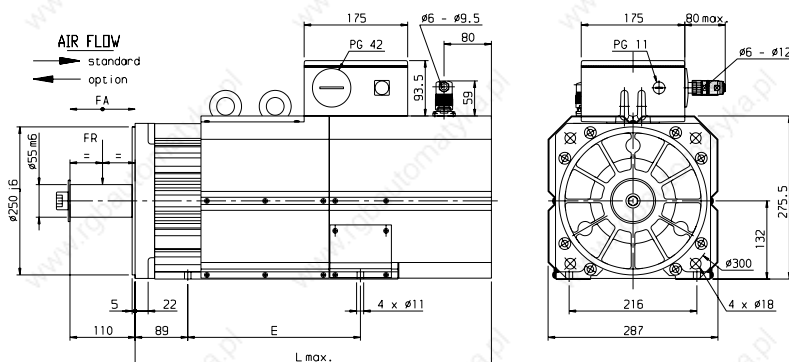

GX GEARBOXES

Characterised by a low backlash, GX gearboxes are ideal for applications needing high torque and optimum motion quality.

In combination with NX servo motors, they offer a compact geared servo motor solution optimised to provide the best dynamic performances.



GX gearboxes - NX servo motors Mechanical associations							
Motor Torque ; Inertia	GX gearbox size						
	01	02	04	06	07	09	10
NX110 0.45 ; 1.3	GX1...R01 r = 3 to 35	GX1...R02 r = 40 to 80					
NX210 1 ; 3.8	GX2...R01 r = 3 to 15	GX2...R02 r = 20 to 35	GX2...R04 r = 40 to 80				
NX310 2 ; 7.9	GX3...R01 r = 3 to 8	GX3...R02 r = 9 to 20	GX3...R04 r = 25 to 60				
NX420 4 ; 29			GX4...R04 r = 3 to 10	GX4...R06 r = 15 to 60	GX4...R07 r = 70 to 90		
NX430 5.5 ; 42.6			GX4...R04 r = 3 to 10	GX4...R06 r = 15 to 35	GX4...R07 r = 40 to 70		
NX620 8 ; 98				GX6...R06 r = 3 to 10	GX6...R07 r = 15 to 60		
NX630 12 ; 147				GX6...R06 r = 3 to 10	GX6...R07 r = 15 to 50		
NX820 16 ; 320				GX8...R06 r = 3 to 10	GX8...R07 r = 15 to 30	GX8...R09 r = 35 to 50	GX8...R10 r = 60 to 80
NX840 28 ; 620				GX8...R06 r = 3 to 9	GX8...R07 r = 10 to 15	GX8...R09 r = 20 to 30	GX8...R10 r = 35 to 50
NX860 41 ; 920				GX8...R06 r = 3 to 7	GX8...R07 r = 8 to 10	GX8...R09 r = 15 to 20	GX8...R10 r = 25 and 35
NX860V 64 ; 920				GX8...R06 r = 3 to 5	GX8...R07 r = 6 and 8	GX8...R09 r = 9 to 15	GX8...R10 r = 20 to 25

r = gearbox ratio, torque (N.m) and Inertia (10⁻⁵.kgm²)

Geared servo motor selection example

Targeted output speed (Ns) : 115 rpm
 Targeted output torque (Cs) : 445 N.m
 Load inertia (Jch) : 3 kgm²

Calculation of the gearbox ratio r

Motor maximum speed (NmaxM) : 4000 rpm
 $r = N_{maxM} / N_s$
 => 4000 / 115 = 34,78

By choosing the existing ratio immediately above : R=35

Calculation of the motor torque

Torque at low speed = $C_s / r / 0.85^*$
 => 445 / 35 / 0.85 = 14.9 N.m

Geared servo motor selection

Motor: NX820 (Torque : 16 N.m, Inertia (Jmot) : 320 kgm².10⁻⁵)
 Gearbox : GX8N035R0900 (size 9 ; speed ratio 35)

Calculation of the inertia ratio**

Inertia ratio = $J_{ch} / (J_{mot} \times r^2)$
 => 3 / (320.10⁻⁵ x 35²) = 0.77

IMPORTANT : please confirm the operating limit of the association selected above with our technical service centre.

HIGH PERFORMANCE GEARED SERVO MOTORS

LARGE CHOICE OF SPEED RATIO

LOW BACKLASH, SMOOTH AND QUIET FUNCTIONING

HIGH STIFFNESS

LIFE LUBRICATED

TOP QUALITY FINISHING

UP TO IP65 PROTECTION

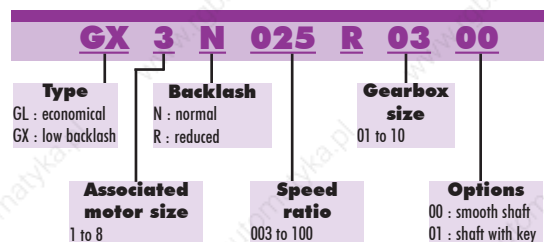

Example : GX3N025R0300

GX gearbox, size 3, ratio 25, normal backlash, smooth shaft, NX310 associated motor

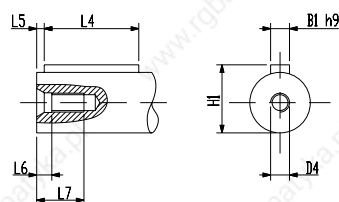
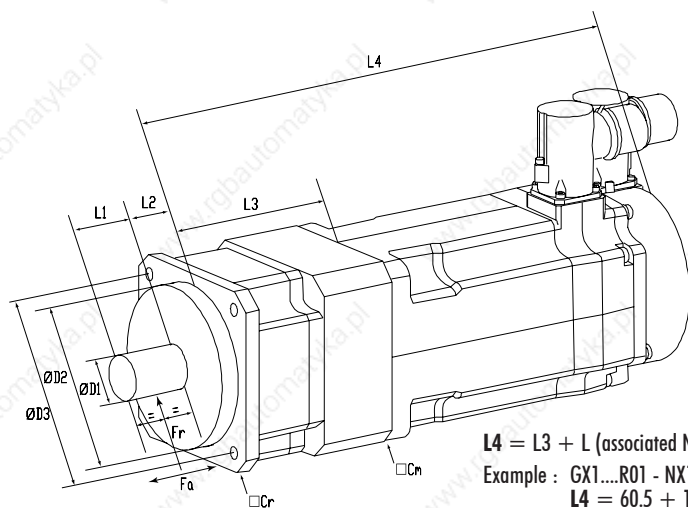

Shaft with key option

$L4 = L3 + L$ (associated NX length, drawing on page 15)

Example : GX1...R01 - NX1 motor : $L = 133$ mm

$L4 = 60.5 + 133 = 193.5$ mm

Geared servo motors characteristics and dimensions - 1 stage GX Ratio 3, 4, 5, 6, 7, 8, 9 and 10

Type	Backlash* (min)	Stiffness (N.m/rad)	Fr** (daN)	Fa** (daN)	L1 (mm)	L2 (mm)	L3 (mm)	D1 (mm)	D2 (mm)	D3 (mm)	Cr (mm)	Cm (mm)	L4 (mm)	L5 (mm)	B1 (mm)	H1 (mm)	L6 (mm)	L7 (mm)	D4 (mm)
GX1...R01	5	10000	78	39	20.5	5.5	60.5	13j6	35g6	46	42	42	16	2	5	15	3.2	10	M4x0.7
GX2...R01	5	10000	78	39	20.5	5.5	60.5	13j6	35g6	46	42	56	16	2	5	15	3.2	10	M4x0.7
GX3...R01	5	10000	78	39	20.5	5.5	60.5	13j6	35g6	46	42	71	16	2	5	15	3.2	10	M4x0.7
GX3...R02	5 or 3	24000	153	76	30	7	76.5	16j6	50g6	70	60	71	25	2	5	18	4	12.5	M5x0.8
GX4...R04	5 or 3	48000	325	162	38	10	96	22j6	80g6	100	90	91.5	32	3	6	24.5	6	19	M8x1.25
GX4...R06	5 or 3	80000	670	335	53	12	122	32j6	110g6	130	115	91.5	40	5	10	35	9.5	28	M12x1.75
GX6...R06	5 or 3	80000	670	335	53	12	122	32j6	110g6	130	115	121	40	5	10	35	9.5	28	M12x1.75
GX8...R06	5 or 3	80000	670	335	53	12	122	32j6	110g6	130	115	155	40	5	10	35	9.5	28	M12x1.75
GX8...R07	5 or 3	170000	940	470	82	15	142.5	40j6	130g6	165	142	155	63	5	12	43	12	36	M16x2
GX8...R09	5 or 3	500000	1450	725	85	20	180.5	55j6	160g6	215	180	155	70	6	16	59	15	42	M20x2.5

* Low backlash option : 3 min; ** at 100 rpm

Cr : Gearbox square - Cm : Motor square

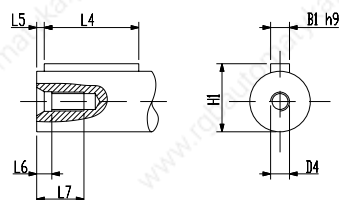
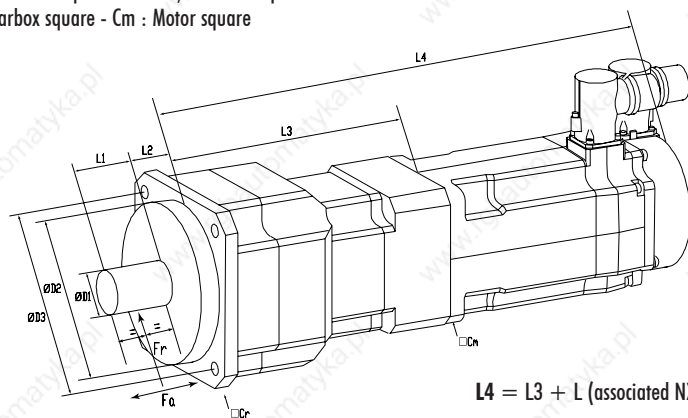

Shaft with key option

$L4 = L3 + L$ (associated NX length, drawing on page 15)

Geared servo motors characteristics and dimensions - 2 stages GX Ratio 15, 20, 25, 30, 35, 40, 45, 50, 60, 70, 80, 90 and 100

Type	Backlash* (min)	Stiffness (N.m/rad)	Fr** (daN)	Fa** (daN)	L1 (mm)	L2 (mm)	L3 (mm)	D1 (mm)	D2 (mm)	D3 (mm)	Cr (mm)	Cm (mm)	L4 (mm)	L5 (mm)	B1 (mm)	H1 (mm)	L6 (mm)	L7 (mm)	D4 (mm)
GX1...R01	8	10000	78	39	20.5	5.5	88	13j6	35g6	46	42	42	16	2	5	15	3.2	10	M4x0.7
GX1...R02	8 or 6	24000	153	76	30	7	101.5	16j6	50g6	70	60	42	25	2	5	18	4	12.5	M5x0.8
GX2...R01	8	10000	78	39	20.5	5.5	88	13j6	35g6	46	42	56	16	2	5	15	3.2	10	M4x0.7
GX2...R02	8 or 6	24000	153	76	30	7	101.5	16j6	50g6	70	60	56	25	2	5	18	4	12.5	M5x0.8
GX2...R04	8 or 6	48000	325	162	38	10	127	22j6	80g6	100	90	56	32	3	6	24.5	6	19	M8x1.25
GX3...R02	8 or 6	24000	153	76	30	7	101.5	16j6	50g6	70	60	71	25	2	5	18	4	12.5	M5x0.8
GX3...R04	8 or 6	48000	325	162	38	10	127	22j6	80g6	100	90	71	32	3	6	24.5	6	19	M8x1.25
GX4...R06	8 or 6	80000	670	335	53	12	161	32j6	110g6	130	115	91.5	40	5	10	35	9.5	28	M12x1.75
GX4...R07	8 or 6	170000	940	470	82	15	196	40j6	130g6	165	142	91.5	63	5	12	43	12	36	M16x2
GX6...R07	8 or 6	170000	940	470	82	15	196	40j6	130g6	165	142	121	63	5	12	43	12	36	M16x2
GX8...R07	8 or 6	170000	940	470	82	15	196	40j6	130g6	165	142	155	63	5	12	43	12	36	M16x2
GX8...R09	8 or 6	500000	1450	725	85	20	232.5	55j6	160g6	215	180	155	70	6	16	59	15	42	M20x2.5
GX8...R10	8 or 6	770000	5000	2500	108	30	274.5	75j6	180g6	235	220	155	90	7	20	79.5	15	42	M20x2.5

* Low backlash option : 6 min; ** at 100 rpm - Cr : Gearbox square - Cm : Motor square

GL GEARBOXES

GL gearboxes are an economical alternative perfectly adapted to usual applications where a low backlash is not requested.

They are associated to NX servo motors of size 1 to 3.

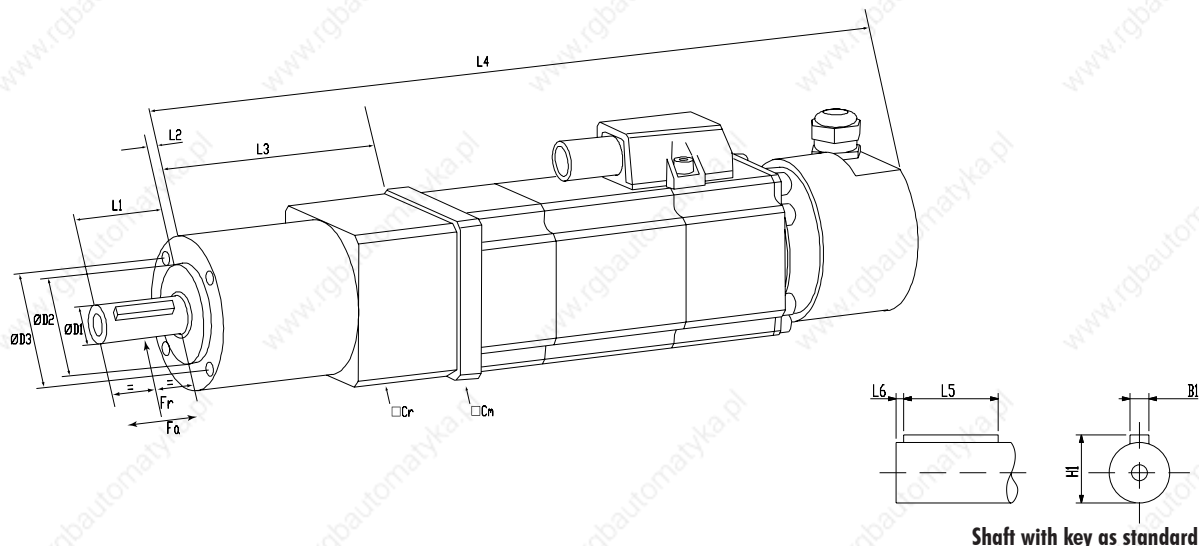

Shaft with key as standard

Geared servo motors characteristics and dimensions - 1 stage GL Ratio 5 and 8

Type	Backlash (min)	Stiffness (N.m/rad)	Fr* (daN)	Fa* (daN)	L1 (mm)	L2 (mm)	L3 (mm)	D1 (mm)	D2 (mm)	D3 (mm)	Cr (mm)	Cm (mm)	L4 no brake (mm)	L4 with brake (mm)	L5 (mm)	L6 (mm)	B1 (mm)	H1 (mm)
GL1...R01	30	1500	20	20	23	2	67.5	10h7	26h7	34	40	42	200.5	231.5	18	2.5	3	11.2
GL2...R02	20	5000	50	60	30	3	71.5	14h7	40h7	52	60	56	208.5	250.5	25	2.5	5	16
GL3...R02	20	5000	50	60	30	3	71.5	14h7	40h7	52	70	71	217.5	265.5	25	2.5	5	16

Geared servo motors characteristics and dimensions - 2 stages GL Ratio 9, 12, 15, 16, 20, and 25

Type	Backlash (min)	Stiffness (N.m/rad)	Fr* (daN)	Fa* (daN)	L1 (mm)	L2 (mm)	L3 (mm)	D1 (mm)	D2 (mm)	D3 (mm)	Cr (mm)	Cm (mm)	L4 no brake (mm)	L4 with brake (mm)	L5 (mm)	L6 (mm)	B1 (mm)	H1 (mm)
GL1...R01	35	1600	20	20	23	2	80.5	10h7	26h7	34	40	42	213.5	244.5	18	2.5	3	11.2
GL2...R02	25	5000	50	60	30	3	83.5	14h7	40h7	52	60	56	220.5	262.5	25	2.5	5	16
GL3...R02	25	5000	50	60	30	3	83.5	14h7	40h7	52	70	71	229.5	277.5	25	2.5	5	16

* at 100 rpm - Cr : Gearbox square - Cm : Motor square

ECONOMICAL GEARED SERVO MOTORS

HIGH COMPACTY

ROBUST DESIGN

LIFE LUBRICATED

UP TO IP54 PROTECTION

Mechanical associations GL gearboxes - NX servo motors

Motor Torque ; Inertia	GL gearbox size	
	01	02
NX110 0.45 ; 1.3	GL1...R01 r = 5 to 64	
NX210 1 ; 3.8		GL2...R02 r = 5 to 64
NX310 2 ; 7.9		GL3...R02 r = 5 to 64

r = speed ratio, Torque (N.m) and Inertia (10⁻⁵.kgm²)

IMPORTANT : please confirm the operating limit of the association selected above with our technical service centre.

BRUSHLESS Accessories

24Vdc power-off holding brake



**24 VDC POWER SUPPLY
(-10%, +6%)**

**STATIC USE : MOTOR LOCKING IN
THE STOPPED POSITION**

**DYNAMIC USE :
FOR EMERGENCY STOPPING ONLY**

**DYNAMIC TORQUE IS
APPROXIMATELY HALF THE
HOLDING TORQUE**

**THE NUMBER OF SWITCHING
OPERATIONS IS LIMITED**

Cables and connectors



24Vdc power-off holding brake

Motor	Holding torque		Power (W)	Inertia (kgm ² .10 ⁻⁵)	Weight (kg)
	at 20°C (N.m)	at 100°C (N.m)			
NX1	0.4	-	6	0.1	0.065
NX2	1.2	-	8	0.7	0.17
NX3	2	1.8	11	0.7	0.18
NX4	5.5	4	12	1.8	0.3
NX6	12	10	18	5.4	0.46
NX8	36	32	26	55.6	3.5
LX4	6	5.5	13	5.3	0.45
LX8	30	28.5	21	46	1.6
HX4	6	5.5	13	5.3	0.45
HX8	30	28.5	21	46	1.6
HXA 30	150	130	95	1250	20.5
HXA 40, 50 and 60	350	310	95	1250	20.5
LS8	15	14	18	41.5	1.3
LS910	25	23.5	18	39	1.3
LS920	30	28.5	21	46	1.6
HS8	15	14	18	41.5	1.3
HS910	25	23.5	18	39	1.3
HS920	30	28.5	21	46	1.6

Servo motor connectors and cables - DIGIVEX

COMPLETE PVC SCREENED CABLE SETS WITH CONNECTORS

Power cable with Molex connector for NX1, NX2	220169R12xx
Power cable with motor plug for NX3, NX4 and NX6 and I<20Å	220171R42xx
Power cable with motor plug for NX6 and NX8 and I<32Å	220171R43xx
Resolver cable with Molex connector and Sub-D for NX1, NX2	220169R21xx
Resolver cable with motor plug and Sub-D for NX3, NX4, NX6 and NX8	220171R61xx

COMPLETE POLYURETHANE CABLE SETS WITH CONNECTORS

Power cable with Molex connector for NX1, NX2	220154R12xx
Power cable with motor plug for NX1, NX2 and I<8Å	220154R32xx
Power cable with motor plug for NX2, NX3, NX4, NX6 and I<4Å	220049R49xx
Power cable with motor plug for NX3, NX4, NX6 / LS8, HS8 and I<8Å	220049R42xx
Power cable with motor plug for NX4, NX6, NX8 / LS8, HS8 and I<32Å	220049R43xx
Power cable with motor plug for LS9, HS9 / LX8, HX8 and I<32Å	220049R48xx
Power cable with motor plug for L.. / H.. and I<60Å	220049R45xx
Power cable with motor plug for L.. / H.. and I<80Å	220049R46xx
Power cable with motor plug for L.. / H.. and I<100Å	220049R47xx
Resolver cable with Molex connector and Sub-D for NX1, NX2	220154R21xx
Resolver cable with motor plug and Sub-D for NX / LX, HX / LS, HS	220049R61xx

POLYURETHANE LOOSE CABLE (NO CONNECTORS)*

Power cable 1mm ² for NX1, NX2 and I<8Å	6537P0023
Power cable 0.5mm ² and I<4Å	6537P0019
Power cable 1mm ² and I<8Å	6537P0009
Power cable 2.5mm ² and I<32Å	6537P0010
Power cable 6mm ² and I<60Å	6537P0011
Power cable 10mm ² and I<80Å	6537P0012
Power cable 16mm ² and I<100Å	6537P0013
Power cable 25mm ² and I<180Å	6537P0014
Resolver cable for NX / LX, HX / LS, HS	6537P0001

LOOSE CONNECTORS

Molex plug kit (power and resolver) for NX1, NX2	220004R1000
Frame size 1 power plug for NX3, NX4, NX6 / LS8, HS8 and I<8Å	220065R1610
Frame size 1 power plug for NX4, NX6, NX8 / LS8, HS8 and I<32Å	220065R1611
Frame size 3 power plug for LS9, HS9 / LX8, HX8 and I<32Å	220065R3611
Frame size 3 power plug for L.. et H.. and I<100Å	220065R3610
Resolver plug	220065R4621

xx cable length in meter ; standard xx = 01, 02, 05, 10 meters
* cable per meter

SERVO MOTORS

HV SPINDLE SERVO MOTORS 4 to 50kW

The HV series are permanent magnet synchronous motors used for machine tool spindle of traditional type (lathes, grinding machines, milling machines).

The control of synchronous technology gives the possibility to reach a speed range ratio at constant power up to 10.

Moreover the HV series present the same characteristics at low speed as an axis servo motor : high torque to weight ratio, low inertia, high torque at low speed...



SPEED UP TO 8000 RPM

TORQUE FROM 17 TO 240N.M

ROBUST AND COMPACT DESIGN

**SPEED RANGE RATIO AT CONSTANT
POWER UP TO 10**

HIGH TORQUE AT LOW SPEED

**LOW INERTIA FOR HIGH
ACCELERATION, RAPID CHANGES IN
SPEED FOR REDUCED TOOL
CHANGING TIME**

IP 54 PROTECTION

CLASS F INSULATION

HV - 400V power supply					
Motor	DIGIVEX ⁽¹⁾ Drive Ratings	Torque S1/S6 (N.m)	Power S1/S6 ⁽²⁾ (kW)	Base/Max speed (rpm)	Inertia (kgm ²)
HV820EZ	16/32	17/20.4	4.3/5.1	2390/8000	0.0035
HV830EM	32/64	25/30	9/10.7	3400/8000	0.0049
HV840EM	32/64	32/38.4	9/10.7	2660/8000	0.0063
HV930EQ	32/64	63.6/70	10/11	1480/7000	0.018
HV930EL	50/80	64/72.5	14.5/16.5	2170/7000	0.018
HV950EQ	32/64	95	10	1020/7000	0.029
HV950EK	50/80	95	15.6	1570/7000	0.029
HVA30JO	50/80	149	16.4	1050/6000	0.027
HVA30JH	100/120	140/157	28/32	1940/6000	0.027
HVA40JH	100/120	200	31	1500/6000	0.035
HVA40JG	150/150	200/240	31/37	1480/6000	0.035

(1) 400V supply voltage
(2) 540V bus voltage

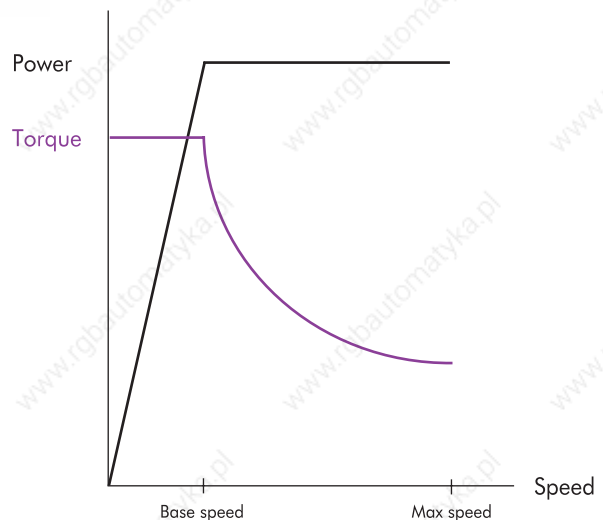

HW ELECTROSPINDLE SYNCHRONOUS MOTORS

2 to 110kW

The HW range of synchronous electrospindle motors has been developed with the aim of solving the problems met in high speed machining.

Compared to conventional asynchronous motors, the HW motors have decisive advantages for quality spindle construction : machining of higher precision, longer bearing lifetime, greater acceleration capacity, higher compactness...

Controlled by the DIGIVEX Drive, the water cooled HW permanent magnets synchronous motors offer torque from 4 to 1250 Nm for speed up to 50000 rpm.

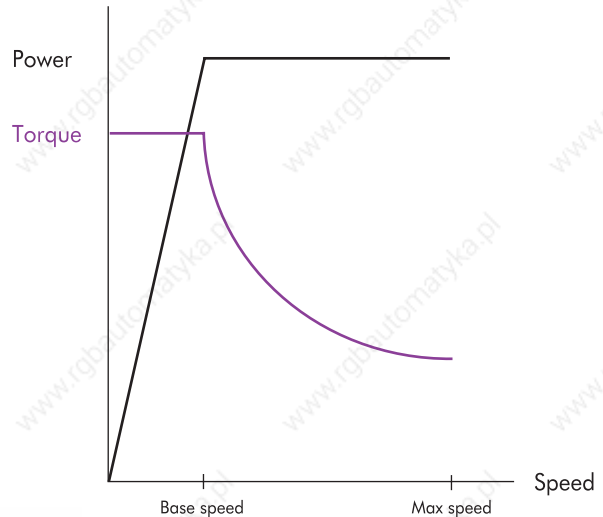

**PERMANENT MAGNETS,
COLD ROTOR TECHNOLOGY**

**LOW INERTIA AND HIGHER
COMPACTNESS COMPARED TO
ASYNCHRONOUS SOLUTION**

**HIGH TORQUE AT LOW SPEED AND
SPEED AT CONSTANT POWER
UP TO 50000 RPM**

**SPEED RANGE RATIO AT CONSTANT
POWER UP TO 10**

TORQUE FROM 4 TO 1250 N.M

INCREASED MACHINING PRECISION

BETTER SURFACE FINISHING

**HIGH ACCELERATION/DECELERATION
FOR RAPID CYCLES**

REDUCED MAINTENANCE

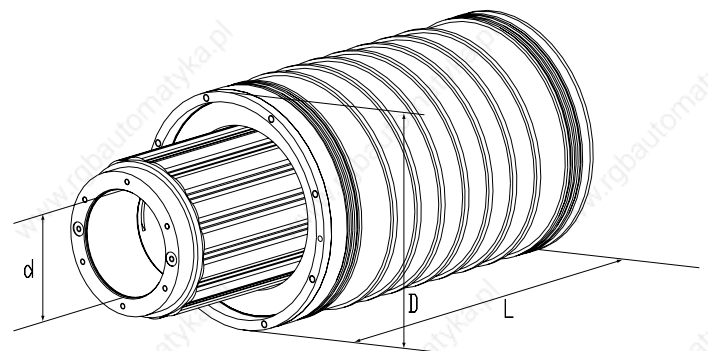

HW - 400V power supply

Motor	DIGIVEX ⁽¹⁾ Drive Rating	Torque S1/S6 (N.m)	Power S1/S6 ⁽²⁾ (kW)	Base/Max speed (rpm)	Inertia (kgm ²)	Weight (kg)	Dimensions (mm)		
							L	D	d
HW420BU	8/16	4.2	2.3	5230/50000	0.00049	3.9	143	100	32
HW420BP	16/32	4.2	5	11250/50000	0.00049	3.9	143	100	32
HW420BK	32/64	4.2	10	23200/50000	0.00049	3.9	143	100	32
HW430BQ	16/32	6.7	4.7	6700/50000	0.00068	5.2	176	100	32
HW430BL	32/64	6.7	10	14300/50000	0.00068	5.2	176	100	32
HW430BI	50/80	6.7	15.6	22300/50000	0.00068	5.2	176	100	32
HW620CN	16/32	8.3/10	4/4.9	4680/30000	0.0017	6.5	159	130	40
HW620CI	32/64	8.3/10	8.6/10.4	9930/30000	0.0017	6.5	159	130	40
HW635CI	32/64	15/18	8.5/10	5410/30000	0.003	11	219	130	40
HW635CF	50/80	15/18	13/15.6	8270/30000	0.003	11	219	130	40
HW820RR	32/64	21.5/26	7.3/8.8	3230/24000	0.007	8	189	180	60
HW820RP	50/80	21.5/26	11.6/14	5140/24000	0.007	8	189	180	60
HW820CR	32/64	25.8/31	8.6/10.3	3170/18000	0.007	8	189	180	60
HW820CP	50/80	25.8/31	13.4/16	4960/18000	0.007	8	189	180	60
HW840CR	32/64	57.3/66	8.5/10	1420/18000	0.0137	16	269	180	60
HW840CP	50/80	57.3/66	13.6/16	2270/24000	0.0137	16	269	180	60
HW840CH	100/120	57.3/66	28/32	4700/24000	0.0137	16	269	180	60
HW840CF	150	57.3/70	36/44	6020/24000	0.0137	16	269	180	60
HW930CI	100/120	102	34	3180/20000	0.034	35	302	220	70
HW930CF	150	102	52	4870/20000	0.034	35	302	220	70
HW930CC	300	102	100	9500/20000	0.034	35	302	220	70
HW930CJ	100/120	112	30	2600/20000	0.034	35	302	220	70
HW930CE	200	112	63	5330/20000	0.034	35	302	220	70
HW950CI	100/120	170	33	1880/20000	0.055	58	422	220	70
HW950CF	150	170	52	2920/20000	0.055	58	422	220	70
HW950CC	300	170	105	5900/20000	0.055	58	422	220	70
HW950CJ	100/120	186	30	1540/20000	0.055	58	422	220	70
HW950CE	200	186	63	3240/20000	0.055	58	422	220	70
HWA30DN	50/80	260	15	550/12000	0.142	70	355	270	106
HWA30DF	100/120	260	32	1190/12000	0.142	70	355	270	106
HWA30DD	150	260	50	1820/12000	0.142	70	355	270	106
HWA30DC	200	260	67	2460/12000	0.142	70	355	270	106
HWA30DB	300	260	100	3710/12000	0.142	70	355	270	106
HWA50DG	100/120	430/510	22/26	490/12000	0.235	120	505	270	106
HWA50DF	100/120	430	31	690/12000	0.235	120	505	270	106
HWA50DD	150	430	49	1080/12000	0.235	120	505	270	106
HWA50DC	200	430	67	1480/12000	0.235	120	505	270	106
HWA50DB	300	430	100	2250/12000	0.235	120	505	270	106
HWB20HH	150	575	46	770/8000	0.35	120	339	340	152
HWB20HD	300	575	95	1580/8000	0.35	120	339	340	152
HWB20HJ	150	600/710	37/44	590/8000	0.35	120	339	340	152
HWB20HE	300	600/710	77/91	1220/8000	0.35	120	339	340	152
HWB30HH	150	860	45	500/8000	0.49	170	439	340	152
HWB30HD	300	860	95	1050/8000	0.49	170	439	340	152
HWB30HJ	150	940/1070	35/40	360/8000	0.49	170	439	340	152
HWB30HE	300	940/1070	76/87	775/8000	0.49	170	439	340	152
HWB40HH	150	1150	44	365/8000	0.64	220	539	340	152
HWB40HD	300	1150	94	780/8000	0.64	220	539	340	152
HWB40HJ	150	1250/1400	34/38	260/5800	0.64	220	539	340	152
HWB40HE	300	1250/1400	75/84	573/8000	0.64	220	539	340	152
HWB40HF	300	1250/1500	62/74	475/8000	0.64	220	539	340	152

(1) 400V supply voltage

(2) 540V bus voltage

AXEM

0.1 to 20N.m

The AXEM motor, with more than 2 million units produced, is one of the most widely spread servo motors in the world.

Its disk rotor, composed solely of copper and insulator, achieves high dynamics and excellent regulation of motion at low speed, as well as silent and vibration-free functioning.

Robust and efficient, low maintenance.



VERY LOW SPEED MODULATION

EXCEPTIONAL REGULATION AT LOW SPEED

**HIGH DYNAMIC CHARACTERISTICS :
LOW ROTOR INERTIA**

SILENT AND VIBRATION-FREE FUNCTIONING

MAINTENANCE FREE

DISK ROTOR

**PROTECTION IP44
IP20 FOR VENTILATED MODELS**

CLASS F INSULATION

AXEM characteristics

Motor	Nominal torque (N.m)	Nominal current (A)	Nominal voltage (V)	Nominal speed (rpm)	Inertia (kgm ² .10 ⁻⁵)
F9M4R	0.14	6.4	22	4800	3.5
F9M2	0.282	11	14	3000	2.9
F9M4	0.346	6.7	26	3000	3.5
F9M4H	0.537	6.5	35	3000	3.4
F12M4R	0.42	8	37	4800	15
F12M2	0.61	11.7	24	3000	10.5
F12M4	0.77	7.7	43	3000	15
F12M4H	1.1	7.2	61	3000	16
MC13S	1.2	7.6	64	3000	23.5
MC17H	1.8	6.9	102	3000	79
MC17B	1.2	24	23.5	3200	79
MC19P	3.2	14.5	83	3000	100
MC19P*	5.1	22.2	87	3000	100
MC19S	3.2	7.3	165	3000	100
MC19S*	5.1	11.1	171	3000	100
MC19B	2.8	46	23.5	3000	100
MC23S	6.1	13	170	3000	230
MC23S*	10.5	21.8	178	3000	230
MC24P	7.3	18.9	136	3000	320
MC24P*	14.3	36	142	3000	320
MC27P	14.3	33	152	3000	740
MC27P*	19.2	44	154	3000	740

*Cooling by external fan 10 l/sec.

Encoder

Type	Associated motor	Pulse / rev.		Inertia (kgm ² .10 ⁻⁵)	Weight (kg)
		standard	option		
K10	F	500	250	0.03	0.07
			250		
C4	F	500	1000	0.23	0.2
			2500		
C6B	MC	500	1000	0.3	0.45
			2500		
			5000		

Tachy

Type	Associated motor	EMF (V/1000 rpm)
F9T	F9	3
FC12T	F12 / MC	6
TBN 206	F9 / F12	6
TBN 420	MC	20

Brake (24Vdc ± 10%)

Associated motor	Holding magnet brake (N.m)	torque spring brake (N.m)	Inertia (kgm ² .10 ⁻³)	Weight (kg)
F9 - F12	-	1.5	1	0.47
MC13	2	-	2.3	0.3
MC17 / MC19	5	-	6.5	0.6
MC23 / MC24	12	-	21.4	1.1
MC27	20	-	57	1.9
MC17	-	4	2.5	1.4
MC19	-	8	7	1.9
MC23 / 24 / 27	-	16	13.5	2.8

DC SERVO MOTORS

F9 - 12 dimensions

Motor	L1 (mm)	L2 (mm)	Weight (kg)	Fr* (daN)	Fa* (daN)
F9M4R	34	46.5	1.1	14	2.5
F9M2	52.5	65	2.3	14	2.5
F9M4	52.5	65	2.3	14	2.5
F9M4H	64	76.5	2.8	14	2.5
F12M4R	37.5	51	2.9	14	2.5
F12M2	61.5	71.5	3.85	14	2.5
F12M4	61.5	71.5	3.85	14	2.5
F12M4H	74	84	5	14	2.5

F9 : $\phi B = \phi 110$

F12 : $\phi B = \phi 140$

*Fr and Fa not cumulative

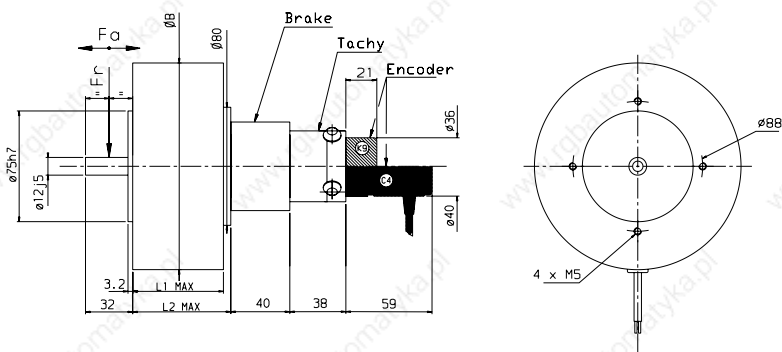

MC13 dimensions

Motor	Weight (kg)	Fr* (daN)	Fa* (daN)
MC13	4	35	13

*Fr and Fa not cumulative

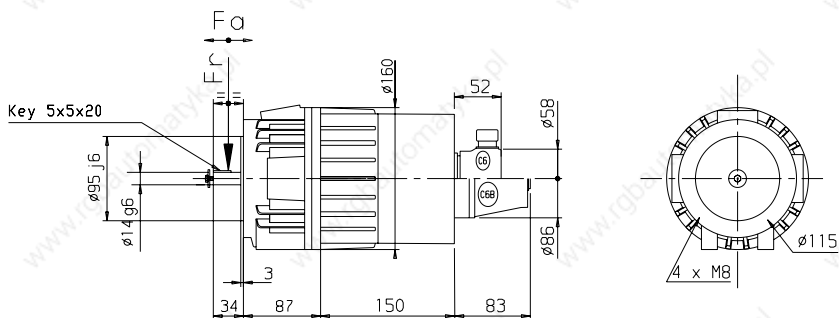

MC17 - 19 dimensions

Motor	M (mm)	N (mm)	N' (mm)	E (mm)	L (mm)	Weight (kg)	Fr* (daN)	Fa* (daN)
MC17	115	95	180	34	163	6.5	60	35
MC19	165	130	130	50	163	9.7	60	35

MC17 : C x HC x LC = 5 x 5 x 20

MC19 : C x HC x LC = 8 x 7 x 32

*Fr and Fa not cumulative

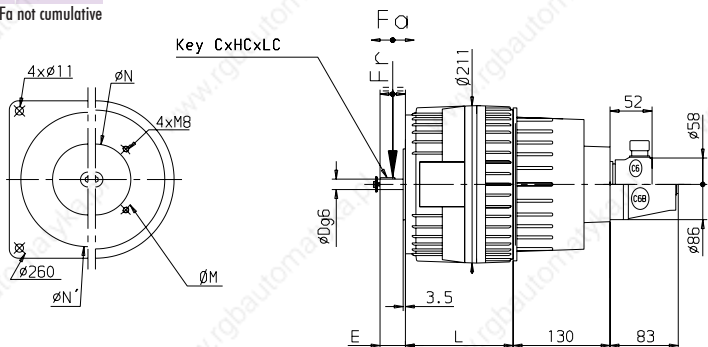

MC23 - 24 - 27 dimensions

Motor	L (mm)	B (mm)	Weight (kg)	Fr* (daN)	Fa* (daN)
MC23	173	278	17	75	40
MC24	185	278	23	80	45
MC27	198	316	35	90	50

*Fr and Fa not cumulative

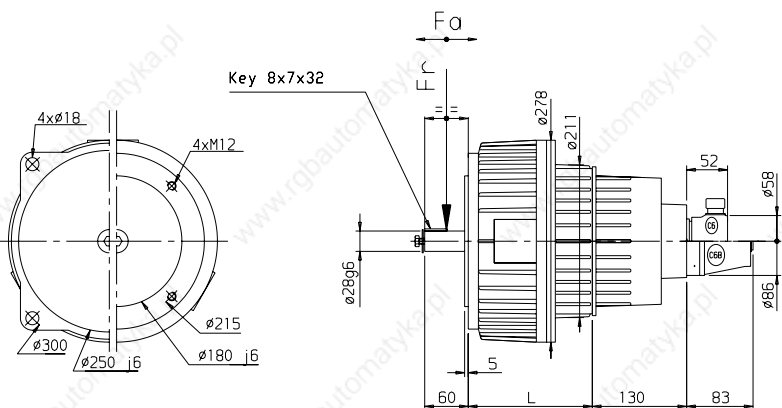

Dimensions including brake, tachy and encoder

RX

0.3 to 8N.m

The RX DC motors, combined with RTS drives, provide an economical solution for any servo mechanism applications.

They are particularly suitable for low power systems in clean atmospheres.



RX characteristics

Motor	Torque at low speed M_0 (N.m)	Permanent current at low speed I_0 (A)	Rated voltage U (V)	Rated speed N (rpm)	Rotor inertia J ($\text{kgm}^2 \cdot 10^{-3}$)
RX120L	0.285	2.8	44.5	3000	5
RX130H	0.4	3.6	46	3000	6.8
RX320E	1.08	7.8	54	3000	50
RX330C	1.54	9.4	59	2900	72
RX520K	2.7	7.7	119	2800	128
RX530F	3.7	10.3	116	2700	174
RX620J	5	10.5	134	2400	350
RX630E	7.8	16	134	2400	500

Associated motor	Tachy		Brake (24Vdc $\pm 10\%$)			
	Type	EMF (V/1000 rpm)	Holding torque (N.m) at 20°C at 100°C		Inertia ($\text{kgm}^2 \cdot 10^{-3}$)	Weight (kg)
RX1	TBN 206	6	1	0.9	1	0.4
RX3	TBN 206	6	1.5	1.4	1	0.18
RX5	TBN 306	6	6	5.5	5.3	0.45
RX6	TBN 306	6	12	11.5	15.7	0.9

Encoder

Type	Associated motor	Pulses per rev.		Inertia ($\text{kgm}^2 \cdot 10^{-3}$)	Weight (kg)
		standard	option		
K10	RX1 / RX3	500	250	0.03	0.07
C4	RX1 / RX3	500	1000-2000	0.23	0.2
C6B	RX5 / RX6	500-1000	2500-5000	0.3	0.45

EXCELLENT PRICE/PERFORMANCE RATIO

VERY LOW TORQUE MODULATION

FERRITE MAGNETS

CONSTRUCTION QUALITY

VERY LONG LIFETIME

TACHY, ENCODER, RESOLVER OPTION

BRAKE OPTION

**PROTECTION IP40 (RX1 AND RX3)
IP54 (RX5 AND RX6), IP55 OPTION**

CLASS F INSULATION

DC SERVO MOTORS

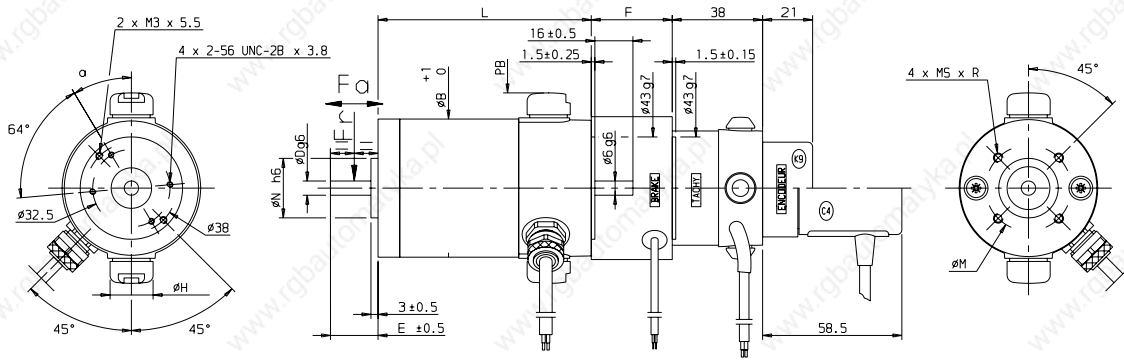

RX1 and RX3 with brake, tachy and encoder dimensions

Motor	H	α	N	D	E	B	PB	L	F	MSxR	M	Weight	Fr* (daN)	Fa* (daN)
RX120	18.5	31°	25	6	20	58	80	122.5	34	M4x6	36	1.35	18	16
RX130	18.5	31°	25	6	20	58	80	147.5	34	M4x6	36	1.6	20	16
RX320	23	26°	50	11	32	84	100	178.5	40	M5x10	65	4	45	23
RX330	23	26°	50	11	32	84	100	218.5	40	M5x10	65	5.2	50	23

*Fr and Fa not cumulative
Dimensions in mm
Weight in kg

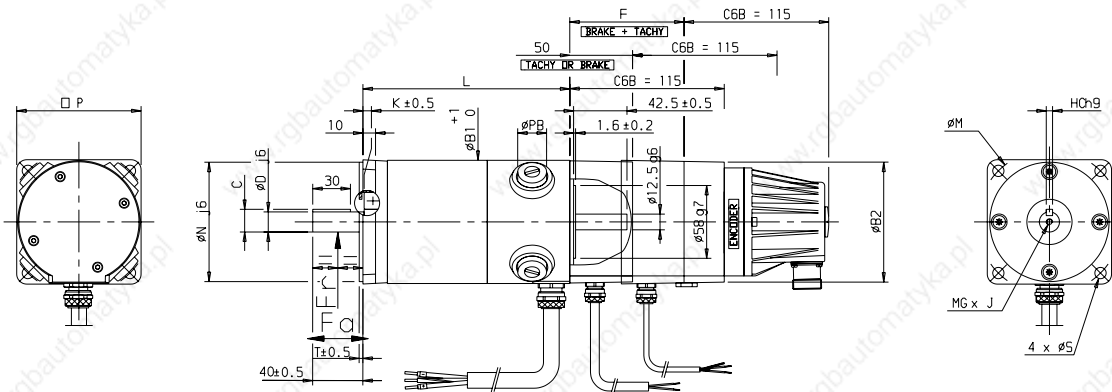

RX5 and RX6 with brake, tachy and encoder dimensions

Motor	P	N	C	D	T	K	B1	PB	L	F	B2	S	M	MGxJ	HC	Weight	Fr* (daN)	Fa* (daN)
RX520	100	95	18	16	3	1	98	25	216	91	96	9	115	M5x15	5	6.6	80	30
RX530	100	95	18	16	3	1	98	25	266	91	96	9	115	M5x15	5	8.7	85	30
RX620	120	110	21.5	19	3.5	0.5	116	30	272	93	117	10	130	M6x18	6	13	95	40
RX630	120	110	21.5	19	3.5	0.5	116	30	358	93	117	10	130	M6x18	6	18.5	100	40

*Fr and Fa not cumulative
Dimensions in mm
Weight in kg

DC SERVO MOTORS

RS

0.05 to 13N.m

Using high energy magnets, RS DC motors combined with RTS drives are particularly suitable for applications which require a very compact solution or a high dynamic level.



RS characteristics

Motor	Torque at low speed M_0 (N.m)	Permanent current at low speed I_0 (A)	Rated voltage U (V)	Rated speed N (rpm)	Rotor inertia J ($\text{kgm}^2 \cdot 10^{-5}$)
RS110M	0.05	1.5	20.7	3000	0.24
RS120G	0.092	2.3	21.2	3000	0.41
RS130E	0.13	2.7	23.7	3000	0.58
RS210L	0.11	2.5	24	3000	1.3
RS220F	0.225	4.1	25.4	3000	1.95
RS220K	0.232	2.8	38.6	3000	1.95
RS230C	0.31	5.6	24	3000	2.6
RS240B	0.39	6	27.6	3000	3.25
RS310N	0.28	2.6	49	3000	5.4
RS320H	0.54	4.5	49	3000	8.3
RS330E	0.78	5.9	51	3000	11
RS340C	0.98	6.9	53	3000	14
RS410R	0.48	3.6	60	3000	13.7
RS420J	0.93	6.2	60	3000	22.5
RS430F	1.3	8.1	43	2000	31
RS430H	1.36	6.6	78	3000	31
RS440G	1.74	7	90	3000	40
RS510L	1.9	7.9	82	2700	100
RS520G	3.1	10.9	92	2700	135
RS530E	4	13	97	2700	170
RS540C	5	15	104	2700	205
RS620G	8	22.3	100	2400	530
RS630F	10.8	25	100	2000	680
RS640E	13	28	105	2000	830

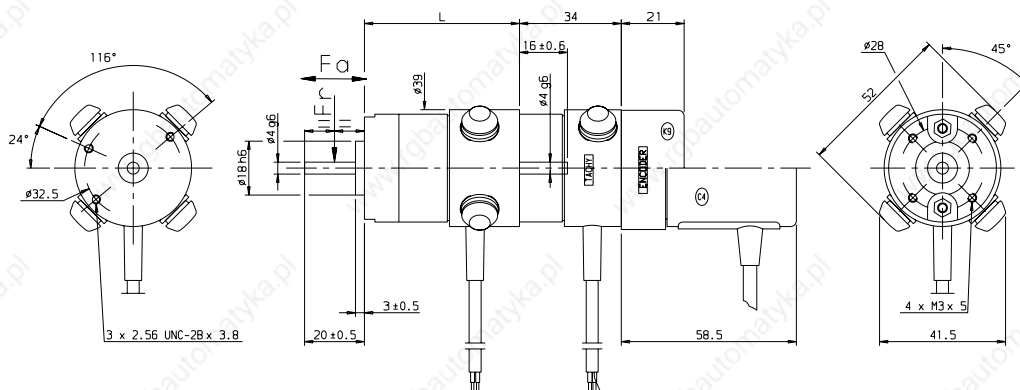

HIGH PERFORMANCE CHARACTERISTICS

EXCELLENT LOW-SPEED FUNCTIONING

RARE EARTH MAGNETS

4-POLE DESIGN

HIGH COMPACTNESS

VERY LONG LIFETIME

TACHY, ENCODER, RESOLVER OPTIONS

BRAKE OPTION

**PROTECTION IP40 (RS1 TO RS4), IP44 OPTION
IP54 (RS5 AND RS6), IP55 OPTION**

CLASS F INSULATION

RS1 dimensions

Motor	L	Weight	Fr* (daN)	Fa* (daN)
RS110	52.1	0.27	6	3
RS120	68.1	0.36	6	3
RS130	84.1	0.45	6	3

*Fr and Fa not cumulative
Dimensions in mm
Weight in kg

DC SERVO MOTORS

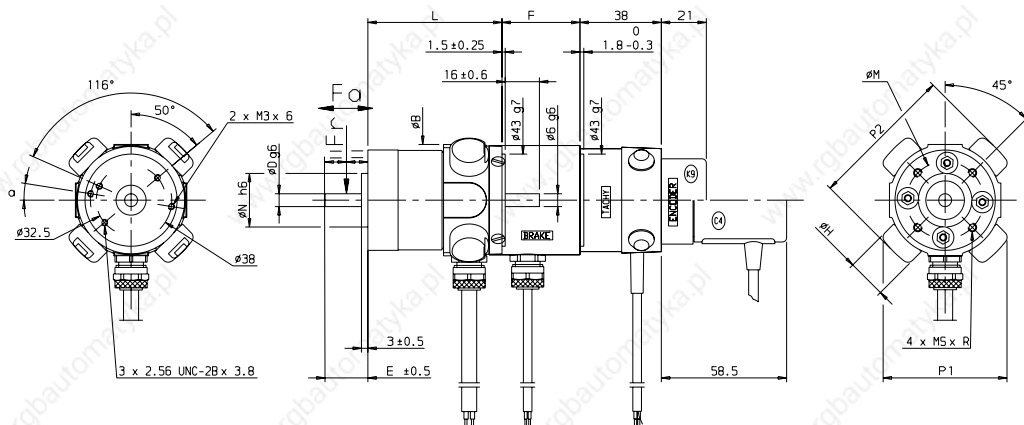

RS2, RS3 and RS4 with brake, tachy and encoder dimensions

Motor	α	N	D	E	B	L	F	P1	P2	H	MSxR	M	Weight	Fr* (daN)	Fa* (daN)
RS210	9°	25	6	20	52	63	36.4	58	68	18.5	M4x6	36	0.54	18	10
RS220	9°	25	6	20	52	79	36.4	58	68	18.5	M4x6	36	0.7	18	10
RS230	9°	25	6	20	52	95	36.4	58	68	18.5	M4x6	36	0.86	18	10
RS240	9°	25	6	20	52	111	36.4	58	68	18.5	M4x6	36	1	18	10
RS310	-	32	9	25	68	80.5	41	69	83	18.5	M5x8	45	0.9	28	15
RS320	-	32	9	25	68	100.5	41	69	83	18.5	M5x8	45	1.3	28	15
RS330	-	32	9	25	68	120.5	41	69	83	18.5	M5x8	45	1.6	28	15
RS340	-	32	9	25	68	140.5	41	69	83	18.5	M5x8	45	2	28	15
RS410	-	50	11	32	83	95.5	40	82	98	22	M5x8	65	1.2	40	20
RS420	-	50	11	32	83	115.5	40	82	98	22	M5x8	65	1.8	40	20
RS430	-	50	11	32	83	135.5	40	82	98	22	M5x8	65	2.4	40	20
RS440	-	50	11	32	83	155.5	40	82	98	22	M5x8	65	3	40	20

*Fr and Fa not cumulative
Dimensions in mm
Weight in kg

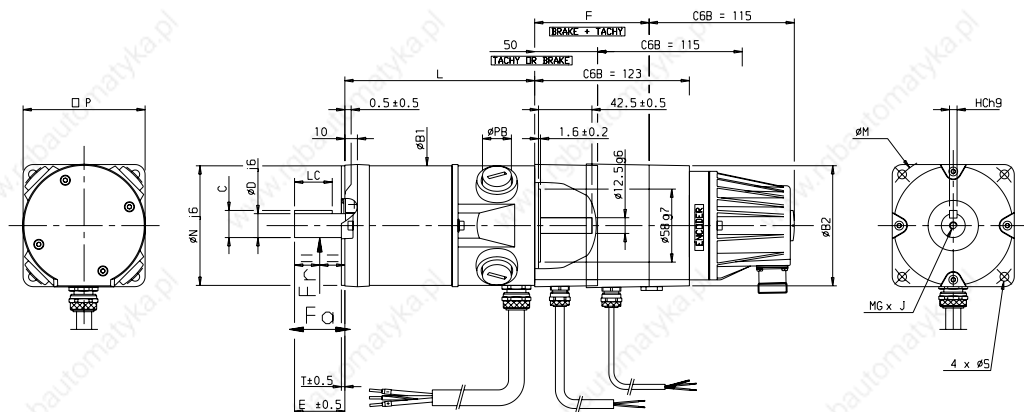

RS5 and RS6 with brake, tachy and encoder dimensions

Motor	P	N	C	D	LC	E	T	B1	PB	L	F	B2	S	M	MGxJ	HC	Weight	Fr* (daN)	Fa* (daN)
RS510	97	95	21.5	19	30	40	3	96	25	151	91	96	7	115	M6x18	6	5.1	70	23
RS520	97	95	21.5	19	30	40	3	96	25	180	91	96	7	115	M6x18	6	6.3	70	23
RS530	97	95	21.5	19	30	40	3	96	25	209	91	96	7	115	M6x18	6	7.5	70	23
RS540	97	95	21.5	19	30	40	3	96	25	238	91	96	7	115	M6x18	6	8.7	70	23
RS620	120	110	27	24	40	50	3.5	117	30	246	93	117	10	130	M8x20	8	11.5	80	26
RS630	120	110	27	24	40	50	3.5	117	30	284	93	117	10	130	M8x20	8	14	80	26
RS640	120	110	27	24	40	50	3.5	117	30	321	93	117	10	130	M8x20	8	16.3	80	26

*Fr and Fa not cumulative
Dimensions in mm
Weight in kg

RTS

3 to 40A

The RTS servo amplifiers are designed for driving DC servo motors and are available in numerous ratings up to 6.5 kW.

These products enable speed control of DC motors with or without tachometers.

They integrate main supply, auxiliary supply and braking resistor circuits in a compact package.



BATTERY, SINGLE-PHASE OR THREE-PHASE POWER SUPPLY

U-RI OR TACHOMETER CONTROL

INTEGRATED BRAKING RESISTOR

FULL PROTECTING FEATURES

HIGH COMPACTNESS

**PANEL OR RACK MOUNTING
3U EUROCARD**

TECHNICAL SPECIFICATIONS

Power supply - Single-phase, three-phase or battery

Ambient - 0-40°C (derate 35%/10°C up to 60°C max)
Up to 1000m ASL (derate 1%/100m up to 4000m max)

Protection - IP00, IP20 for versions with covering cap

RTS characteristics

Type	Supply	Nominal supply voltage $\pm 10\%$	Nominal output voltage (Vdc)	Nominal output current (A)	Peak output current (A)
3/10-40M	single phase	32Vac	40	3	10
10/20-60	single/three	48Vac	60	10	20
12/24-130T	three phase	100Vac	130	12	24
20/40-130T	three phase	100Vac	130	20	40
16/32-190T	three phase	135Vac	190	16	32
40/80-190T	three phase	150Vac	200	40	80
12/24-.B	battery	24-48Vdc	U battery -2V	12	24
40/80-.B	battery	36-72Vdc	U battery -2V	40	80

Dimensions

Type	H (mm)	W* (mm)	D (mm)	M (kg)
Panel mounting				
3/10-40M	150	65	212	1
10/20-60 (mono/tri)	180/150	65	212	1.2
12/24-130T	150	95	212	1.6
20/40-130T	150	121	221	1.9
16/32-190T	150	121	221	1.9
40/80-190T	247	139	205	6
12/24-.B	150	65	212	1
40/80-.B	247	70	205	2.5
Rack mounting				
3/10-40M	130	51	216	0.8
10/20-60 (tri)	130	51	216	0.8
12/24-130T	130	61	216	0.85
12/24-.B	130	51	216	0.8

* maximum dimensions with covering cap

STANDARDS

CE marked

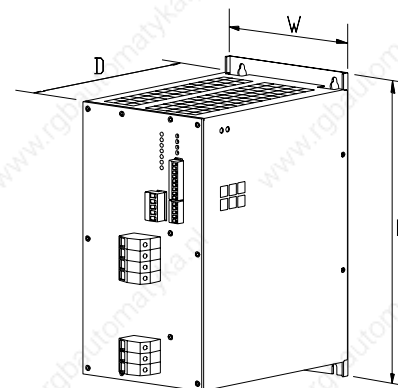

DC SERVO MOTORS AND SERVO DRIVES

Accessories

Tacho generators

Mounted directly on the shaft, making them very rigid, the tacho generators designed with high precision give a very good image of instantaneous speed, of zero speed and of rotation direction.

Power-off holding brake

Static use : motor locking in the stopped position
Dynamic use : for emergency braking only

Encoder



Particularly compact, the K10 encoder is mounted directly on the shaft, accordingly axial loads on the shaft are not permitted.

The C4 encoder with its hollow shaft and flexible mounting arrangement allows a very compact design

The C6B encoder is well-adapted to highly industrial environment thanks to its reinforced thermal and mechanical protection.

Transformer and choke

The transformer and choke ranges offer a large choice for all applications of the RTS series.

Associated motor	Tachy		Brake (24Vdc ±10%)			Weight (kg)
	Type	EMF (V/1000 rpm)	Holding torque (N.m) at 20°C at 100°C		Inertia (kgm ² .10 ⁻⁵)	
RX1	TBN206	6	1	0.9	1	0.4
RX3	TBN206	6	1.5	1.4	1	0.18
RX5	TBN306	6	6	5.5	5.3	0.45
RX6	TBN306	6	12	11.5	15.7	0.9
RS1	TBN103	3	-	-	-	-
RS2	TBN206	6	0.6	0.55	0.2	0.2
RS3 / RS4	TBN206	6	1.5	1.4	0.6	0.18
RS5	TBN306	6	6	5.5	5.3	0.45
RS6	TBN306	6	12	11.5	15.7	0.9

Encoder					
Type	Associated motor	Traits par tour		Inertie (kgm ² .10 ⁻⁵)	Masse (kg)
		standard	option		
K10	RX1 / RX3 RS1..RS4	500	250	0.03	0.07
C4	RX1 / RX3 RS1..RS4	500	1000-2000	0.23	0.2
C6B	RX5 / RX6 RS5 / RS6	500-1000	2500-5000	0.3	0.45

Transformer (230V/400V primary)		
Type	Secondary (±5%)	Power (kVA)
TT 11133	32V single phase	0.12
TT 11134	32V single phase	0.63
TT 11135	48V single phase	0.63
TT 11136	48V three phase	0.5
TT 11137	48V three phase	1.6
TT 11138	48V three phase	2.5
TT 11144	100V three phase	0.63
TT 11145	100V three phase	1
TT 11139	100V three phase	1.6
TT 11140	100V + 48V three phase	2.5
TT 11141	100V + 48V three phase	4
TT 11115	135V three phase	1
TT 11116	135V three phase	1.6
TT 11117	135V three phase	2.5
TT 11118	135V three phase	4
TT 11119	135V three phase	6.3
TT 11120	135V three phase	10

Choke		
Type	Current (A)	Inductance (mH)
SF 02031	12	1
SF 02022	16	2.5
SF 02023	25	1.5
SF 02024	40	1.25

Filter	
Type	Description
FR 13020	20A single/three phase main filter

OPERATOR TERMINALS

Text terminals



VT50 - LCD - 2 x 20
L=166, H=86, P=41



VT60 - LCD - 4 x 20
L=166, H=86, P=41



VT150 - LCD - 4 x 20
L=148, H=188, P=41

Graphic terminals



VT300 - LCD monochrome
L=252, H=196, P=60



VT155 - LCD touchscreen monochrome
L=100, H=166, P=39.6



VT505 - LCD touchscreen monochrome
L=210, H=158, P=54

TEXT AND GRAPHIC MODELS

OPERATOR TERMINALS WITH INTEGRATED CANOPEN CONNECTION

SSD DRIVES PROTOCOLE EI ASCII RS232/RS485 (OPTION)

PARVEX MOTION EXPLORER SOFTWARE

Parvex Motion Explore is a powerful Windows based software for the DIGIVEX range.

This software provides a convenient and straightforward working environment due to its graphic display of functions and an easy choice of different headings, in the form of thumbnails and menus.



CANopen or PROFIBUS network management
Simple click access to all subscribers on network.

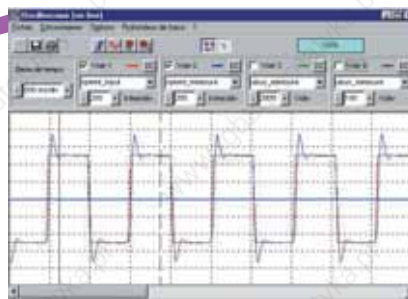

4 channel oscilloscope
Adjustable time base; adjustable trigger; RMS, peak-to-peak, average, min, max measures...

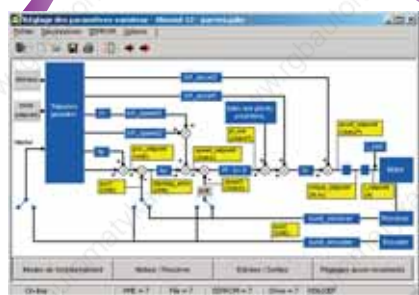

Parameter adjustment
Axis, motor, sensor, input/output configuration; tuning assistant...



Variable observer
Display and software forcing



Diagnostic help
event history; troubleshooting assistant; firmware update...

- ▶ Program editor, compilation with error localisation
- ▶ Stimuli generator
- ▶ Program development debugger
- ▶ Cam editor

EASYSRIDER SOFTWARE

EasyRider is a graphical software for the 630 Series providing a single user interface for accessing all drive parameters, programming motion and calibrating the drive.

This unique assistant offer an autopilot mode helping user in all phases of application set-up : from the choice of the motor in the motor library to the drive auto-adjustment. All set-up steps are extremely simplified. Easyrider gives also the possibility to develop advanced motion in an intuitive way using its BIAS language.

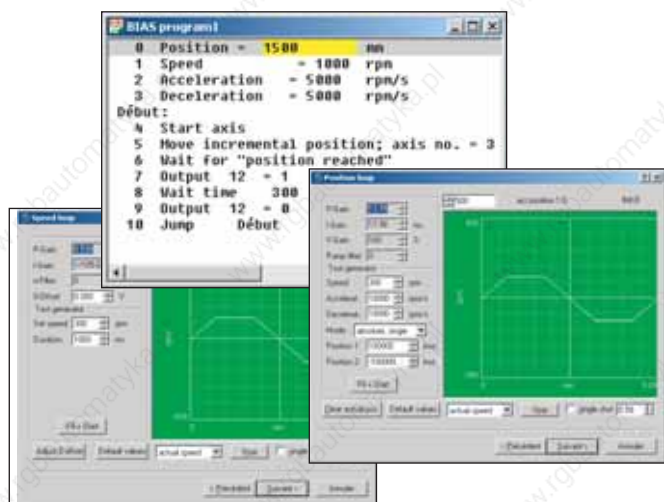

INTUITIVE AND EASY USE

SET-UP ASSISTANT

INTEGRATED MOTOR LIBRARY

OSCILLOSCOPE FUNCTION

DRIVE AND FIELDBUS DIAGNOSTIC

DRIVE ADVANCED PROGRAMMING

A COMPLETE MULTI-AXIS SERVO APPLICATION ON CANOPEN



Parvex Motion Explorer Use :

- Parameter definition
- Oscilloscope
- Control

DIGIVEX Motion Operating mode :

- Master slave synchronisation
- PDO messages, interpolation
- Multi-axis supervision

Applications Examples :

- Palletising
- Packaging
- Bending

One unique machine plug using CANopen bus gives opportunity to develop all the tasks for the realisation of an advanced application : Parameter Definition, Adjustment, Control.

TEST BENCH FOR WIND TUNNEL

SSD Drives Parvex offer

1 HX820VR servo motor controlled by a DIGIVEX Single Motion positioning-drive. Dedicated PC software, specifically developed by SSD Drives Parvex, allowing cam construction using customer data, program compilation with new values and its transfer to drive.

Customer benefits

Application of positioning integrally managed by SSD Drives Parvex including cabinet wiring and DIGIVEX Motion and PC software development.



HX820

DIGIVEX Single Motion

Dedicated PC software



STAYLOG SLICING MACHINE

APPLICATIONS

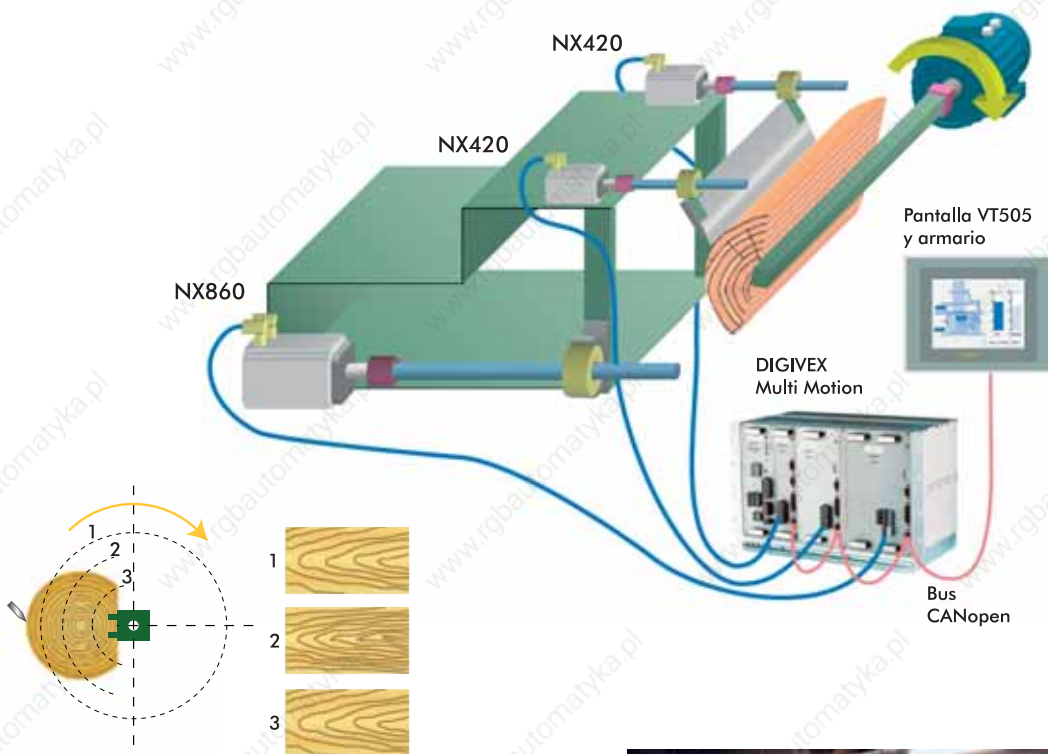

SSD Drives Parvex offer

2 NX420 servo motor and 1 NX 860 servo motor powered by a 3 axis DIGIVEX Multi Motion positioning system for the position control of knife and carriage. 1 VT505 graphic terminal for input of production data and operating modes.

Customer benefits

Positioning-drive replacing axis card for an improved reliability and increased performances.

FRANCE

SSD Drives SAS

15 avenue de Norvège, Villebon sur Yvette, F-91953 Courtaboeuf Cedex
Tel : +33 (0)1 69 18 51 51 - Fax : +33 (0)1 69 18 51 59

SSD Parvex SAS

8 avenue du Lac, BP 249, F-21007 Dijon Cedex
Tel : +33 (0)3 80 42 41 40 - Fax : +33 (0)3 80 42 41 23

ITALY

SSD Drives SpA

Via gran Sasso 9, 20030 Lentate Sul Seveso (Milano)
Tel : +39 03 62 55 73 08 - Fax : +39 03 62 55 73 12

ENGLAND

SSD Drives Ltd.

New Courtwick Lane, Littlehampton, West Sussex, BN17 7RZ
Tel : +44 (0)1 903 737 000 - Fax : +44 (0)1 903 737 100

GERMANY

SSD Drives GmbH

Von-Humboldt - Strasse 10, 64646 Heppenheim
Tel: +49-6252-7982-00 Fax: +49-6252-7982-05

SWEDEN

SSD Drives AB

Box 9084, S30013 Halmstad
Tel: +46-35-177300 Fax: +46-35-108407

UNITED STATES (North America)

SSD Drives Inc.

9225 Forsyth Park Drive, Charlotte, North Carolina 28273-3884
Tel: +1-704-588-3246 Fax: +1-704-588-4806

