

MOS INTEGRATED CIRCUIT

μ PD42S4260, 424260

4 M-BIT DYNAMIC RAM

256 K-WORD BY 16-BIT, FAST PAGE MODE, BYTE READ/WRITE MODE

Description

The μ PD42S4260, 424260 are 262,144 words by 16 bits dynamic CMOS RAMs. The fast page mode and byte read/write mode capability realize high speed access and low power consumption.

Besides, the μ PD42S4260 can execute $\overline{\text{CAS}}$ before $\overline{\text{RAS}}$ self refresh.

These are packaged in 44-pin plastic TSOP (II) and 40-pin plastic SOJ.

Features

- 262,144 words by 16 bits organization
- Single +5.0 V ± 10 % power supply
- Fast access and cycle time

Part number	Power consumption Active (MAX.)	Access time (MAX.)	R/W cycle time (MIN.)	Fast page mode cycle time (MIN.)
μ PD42S4260-60, 424260-60	880.0 mW	60 ns	110 ns	40 ns
μ PD42S4260-70, 424260-70	880.0 mW	70 ns	130 ns	45 ns
μ PD42S4260-80, 424260-80	797.5 mW	80 ns	150 ns	50 ns

- The μ PD42S4260 can execute $\overline{\text{CAS}}$ before $\overline{\text{RAS}}$ self refresh

Part number	Refresh cycle	Refresh	Power consumption at standby (MAX.)
μ PD42S4260	512 cycles / 128 ms	$\overline{\text{CAS}}$ before $\overline{\text{RAS}}$ self refresh, $\overline{\text{CAS}}$ before $\overline{\text{RAS}}$ refresh, $\overline{\text{RAS}}$ only refresh, Hidden refresh	0.825 mW (CMOS level input)
μ PD424260	512 cycles / 8 ms	$\overline{\text{CAS}}$ before $\overline{\text{RAS}}$ refresh, $\overline{\text{RAS}}$ only refresh, Hidden refresh	5.5 mW (CMOS level input)

- Multiplexed address inputs ... Row address: A0 to A8, Column address: A0 to A8

Ordering Information

Part number	Access time (MAX.)	Package	Refresh
μPD42S4260G5-60	60 ns	44-pin Plastic TSOP (II) (400 mil)	$\overline{\text{CAS}}$ before $\overline{\text{RAS}}$ self refresh $\overline{\text{CAS}}$ before $\overline{\text{RAS}}$ refresh $\overline{\text{RAS}}$ only refresh Hidden refresh
μPD42S4260G5-70	70 ns		
μPD42S4260G5-80	80 ns		
μPD42S4260LE-60	60 ns	40-pin Plastic SOJ (400 mil)	
μPD42S4260LE-70	70 ns		
μPD42S4260LE-80	80 ns		
μPD424260G5-60	60 ns	44-pin Plastic TSOP (II) (400 mil)	$\overline{\text{CAS}}$ before $\overline{\text{RAS}}$ refresh $\overline{\text{RAS}}$ only refresh Hidden refresh
μPD424260G5-70	70 ns		
μPD424260G5-80	80 ns		
μPD424260LE-60	60 ns	40-pin Plastic SOJ (400 mil)	
μPD424260LE-70	70 ns		
μPD424260LE-80	80 ns		

Pin Configurations (Marking Side)

44-pin Plastic TSOP (II)
(400 mil)

40-pin Plastic SOJ
(400 mil)

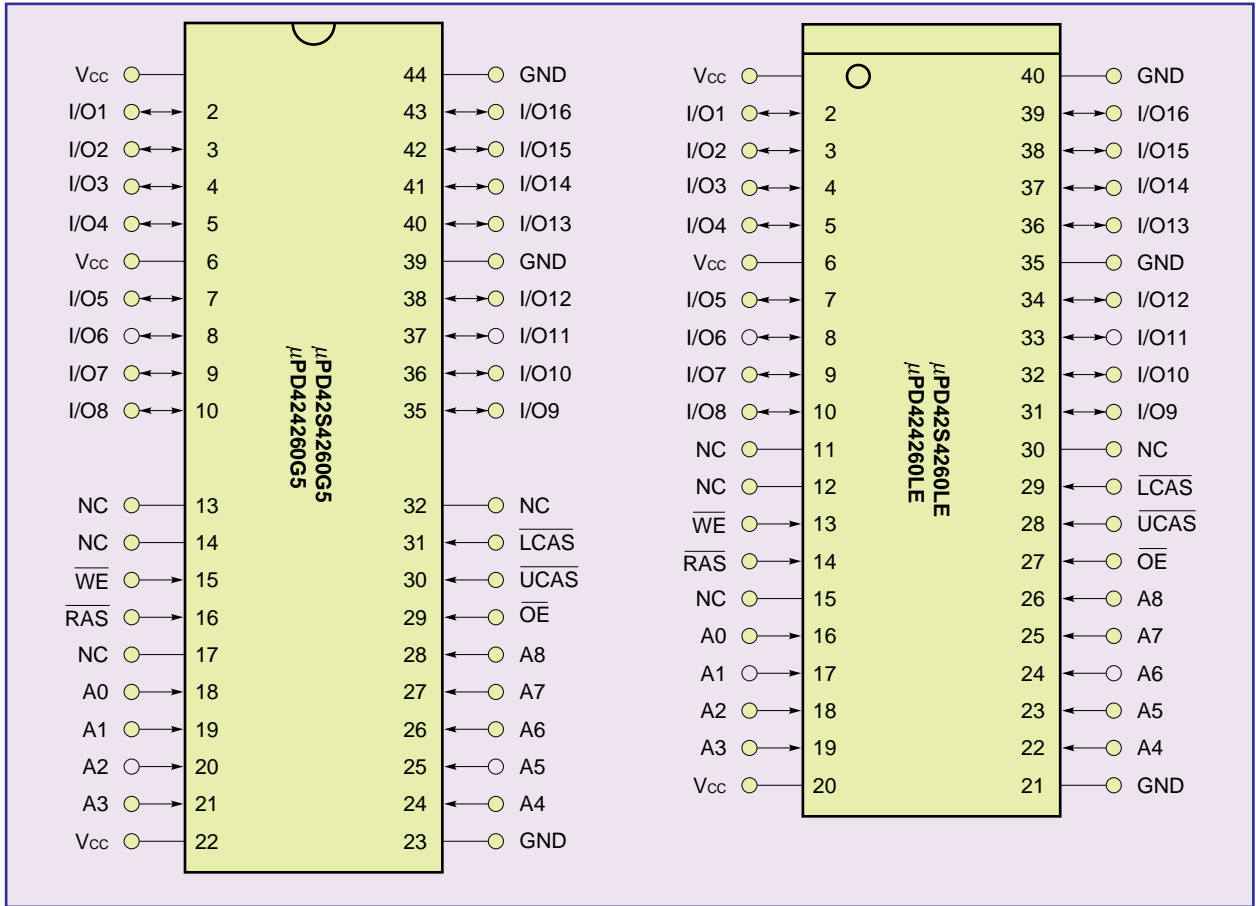

- A0 to A8 : Address Inputs
- I/O1 to I/O16 : Data Inputs/Outputs
- RAS : Row Address Strobe
- UCAS : Column Address Strobe (upper)
- LCAS : Column Address Strobe (lower)
- WE : Write Enable
- OE : Output Enable
- Vcc : Power Supply
- GND : Ground
- NC : No Connection

Block Diagram

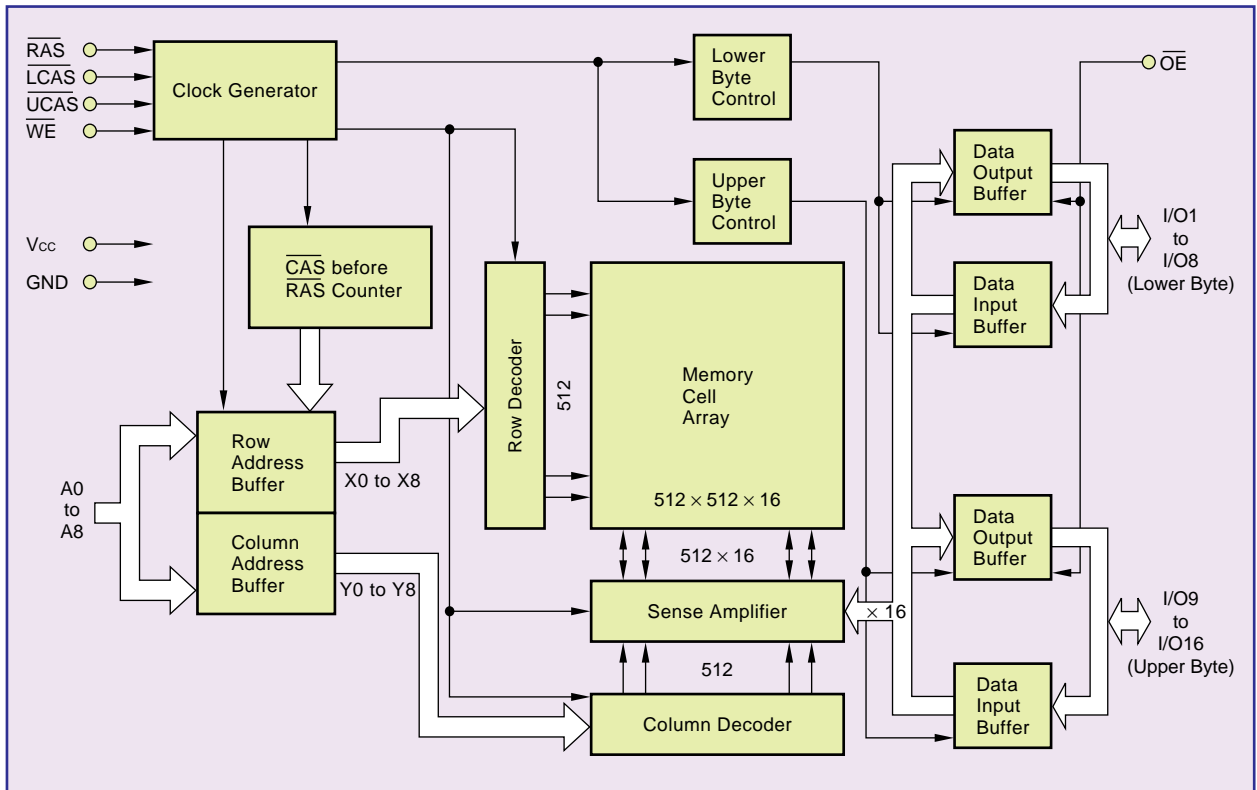

Input/Output Pin Functions

The μPD42S4260, 424260 have input pins \overline{RAS} , \overline{CAS} ^{Note}, \overline{WE} , \overline{OE} , A0 to A8 and input/output pins I/O1 to I/O16.

Pin name	Input/ Output	Function
\overline{RAS} (Row address strobe)	Input	\overline{RAS} activates the sense amplifier by latching a row address (A0 to A8) and selecting a corresponding word line. It refreshes memory cell array of one line selected by the row address (A0 to A8). It also selects the following function. • \overline{CAS} before \overline{RAS} refresh
\overline{CAS} (Column address strobe)	Input	\overline{CAS} activates data input/output circuit by latching column address (A0 to A8) and selecting a digit line connected with the sense amplifier.
A0 to A8 (Address input)	Input	9-bit address bus. Input total 18-bit of address signal, upper 9-bit and lower 9-bit in sequence (address multiplex method). Therefore, one word (16-bit) is selected from 262,144-word by 16-bit memory cell array. In actual operation, latch row address by specifying row address and activating \overline{RAS} . Then, switch the address bus to column address and activate \overline{CAS} . Each address is taken into the device when \overline{RAS} and \overline{CAS} are activated. Therefore, the address input setup time (t_{ASR} , t_{ASC}) and hold time (t_{RAH} , t_{CAH}) are specified for the activation of \overline{RAS} and \overline{CAS} .
\overline{WE} (Write enable)	Input	Write control signal. Write operation is executed by activating \overline{RAS} , \overline{CAS} and \overline{WE} .
\overline{OE} (Output enable)	Input	Read control signal. Read operation can be executed by activating \overline{RAS} , \overline{CAS} and \overline{OE} . If \overline{WE} is activated during read operation, \overline{OE} is to be ineffective in the device. Therefore, read operation cannot be executed.
I/O1 to I/O16 (Data input/ output)	Input/ Output	16-bit data bus. I/O1 to I/O16 are used to input/output data.

Note \overline{CAS} means \overline{UCAS} and \overline{LCAS} .

Electrical Specifications

- $\overline{\text{CAS}}$ means $\overline{\text{UCAS}}$ and $\overline{\text{LCAS}}$.
- All voltages are referenced to GND.
- After power up ($V_{CC} \geq V_{CC(\text{MIN.})}$), wait more than 100 μs ($\overline{\text{RAS}}$, $\overline{\text{CAS}}$ inactive) and then, execute eight $\overline{\text{CAS}}$ before $\overline{\text{RAS}}$ or $\overline{\text{RAS}}$ only refresh cycles as dummy cycles to initialize internal circuit.

Absolute Maximum Ratings

Parameter	Symbol	Condition	Rating	Unit
Voltage on any pin relative to GND	V_T		-1.0 to +7.0	V
Supply voltage	V_{CC}		-1.0 to +7.0	V
Output current	I_O		50	mA
Power dissipation	P_D		1	W
Operating ambient temperature	T_A		0 to +70	°C
Storage temperature	T_{stg}		-55 to +125	°C

Caution Exposing the device to stress above those listed in Absolute Maximum Ratings could cause permanent damage. The device is not meant to be operated under conditions outside the limits described in the operational section of this specification. Exposure to Absolute Maximum Rating conditions for extended periods may affect device reliability.

Recommended Operating Conditions

Parameter	Symbol	Condition	MIN.	TYP.	MAX.	Unit
Supply voltage	V_{CC}		4.5	5.0	5.5	V
High level input voltage	V_{IH}		2.4		$V_{CC} + 1.0$	V
Low level input voltage	V_{IL}		-1.0		+0.8	V
Operating ambient temperature	T_A		0		70	°C

Capacitance ($T_A = 25\text{ °C}$, $f = 1\text{ MHz}$)

Parameter	Symbol	Test condition	MIN.	TYP.	MAX.	Unit
Input capacitance	C_{I1}	Address			5	pF
	C_{I2}	$\overline{\text{RAS}}$, $\overline{\text{CAS}}$, $\overline{\text{WE}}$, $\overline{\text{OE}}$			7	pF
Data input/output capacitance	$C_{I/O}$	I/O			7	pF

DC Characteristics (Recommended Operating Conditions unless otherwise noted)

Parameter		Symbol	Test condition	MIN.	TYP.	MAX.	Unit	Notes
Operating current		I _{CC1}	$\overline{\text{RAS}}, \overline{\text{CAS}}$ cycling $t_{\text{RC}} = t_{\text{RC}(\text{MIN.})}, I_{\text{O}} = 0 \text{ mA}$	$t_{\text{RAC}} = 60 \text{ ns}$		160	mA	1, 2, 3
				$t_{\text{RAC}} = 70 \text{ ns}$		160		
				$t_{\text{RAC}} = 80 \text{ ns}$		145		
Standby current	μPD42S4260	I _{CC2}	$\overline{\text{RAS}}, \overline{\text{CAS}} \geq V_{\text{IH}(\text{MIN.})}, I_{\text{O}} = 0 \text{ mA}$			2	mA	
			$\overline{\text{RAS}}, \overline{\text{CAS}} \geq V_{\text{CC}} - 0.2 \text{ V}, I_{\text{O}} = 0 \text{ mA}$			0.15		
	μPD424260		$\overline{\text{RAS}}, \overline{\text{CAS}} \geq V_{\text{IH}(\text{MIN.})}, I_{\text{O}} = 0 \text{ mA}$			2		
			$\overline{\text{RAS}}, \overline{\text{CAS}} \geq V_{\text{CC}} - 0.2 \text{ V}, I_{\text{O}} = 0 \text{ mA}$			1		
RAS only refresh current		I _{CC3}	$\overline{\text{RAS}}$ cycling, $\overline{\text{CAS}} \geq V_{\text{IH}(\text{MIN.})}$ $t_{\text{RC}} = t_{\text{RC}(\text{MIN.})}, I_{\text{O}} = 0 \text{ mA}$	$t_{\text{RAC}} = 60 \text{ ns}$		160	mA	1, 2, 3, 4
				$t_{\text{RAC}} = 70 \text{ ns}$		160		
				$t_{\text{RAC}} = 80 \text{ ns}$		145		
Operating current (Fast page mode)		I _{CC4}	$\overline{\text{RAS}} \leq V_{\text{IL}(\text{MAX.})}, \overline{\text{CAS}}$ cycling $t_{\text{PC}} = t_{\text{PC}(\text{MIN.})}, I_{\text{O}} = 0 \text{ mA}$	$t_{\text{RAC}} = 60 \text{ ns}$		140	mA	1, 2, 5
				$t_{\text{RAC}} = 70 \text{ ns}$		140		
				$t_{\text{RAC}} = 80 \text{ ns}$		130		
CAS before RAS refresh current		I _{CC5}	$\overline{\text{RAS}}$ cycling $t_{\text{RC}} = t_{\text{RC}(\text{MIN.})}, I_{\text{O}} = 0 \text{ mA}$	$t_{\text{RAC}} = 60 \text{ ns}$		160	mA	1, 2
				$t_{\text{RAC}} = 70 \text{ ns}$		160		
				$t_{\text{RAC}} = 80 \text{ ns}$		145		
CAS before RAS long refresh current (512 cycles / 128 ms, only for the μPD42S4260)		I _{CC6}	CAS before RAS refresh: $t_{\text{RC}} = 250.0 \mu\text{s}$ RAS, CAS: $V_{\text{CC}} - 0.2 \text{ V} \leq V_{\text{IH}} \leq V_{\text{IH}(\text{MAX.})}$ $0 \text{ V} \leq V_{\text{IL}} \leq 0.2 \text{ V}$ Standby: $\overline{\text{RAS}}, \overline{\text{CAS}} \geq V_{\text{CC}} - 0.2 \text{ V}$ Address: V_{IH} or V_{IL} WE, OE: V_{IH} $I_{\text{O}} = 0 \text{ mA}$	$t_{\text{RAS}} \leq 200 \text{ ns}$		200	μA	1, 2
				$t_{\text{RAS}} \leq 1 \mu\text{s}$		300	μA	1, 2
Self refresh current (CAS before RAS self refresh, only for the μPD42S4260)		I _{CC7}	$\overline{\text{RAS}}, \overline{\text{CAS}}$: $t_{\text{RASS}} = 5 \text{ ms}$ $V_{\text{CC}} - 0.2 \text{ V} \leq V_{\text{IH}} \leq V_{\text{IH}(\text{MAX.})}$ $0 \text{ V} \leq V_{\text{IL}} \leq 0.2 \text{ V}$ $I_{\text{O}} = 0 \text{ mA}$			150	μA	2
Input leakage current		I _{I(L)}	$V_{\text{I}} = 0 \text{ to } 5.5 \text{ V}$ All other pins not under test = 0 V	-10		+10	μA	
Output leakage current		I _{O(L)}	$V_{\text{O}} = 0 \text{ to } 5.5 \text{ V}$ Output is disabled (Hi-Z)	-10		+10	μA	
High level output voltage		V _{OH}	$I_{\text{O}} = -2.5 \text{ mA}$	2.4			V	
Low level output voltage		V _{OL}	$I_{\text{O}} = +2.1 \text{ mA}$			0.4	V	

- Notes**
- I_{CC1}, I_{CC3}, I_{CC4}, I_{CC5} and I_{CC6} depend on cycle rates (t_{RC} and t_{PC}).
 - Specified values are obtained with outputs unloaded.
 - I_{CC1} and I_{CC3} are measured assuming that address can be changed once or less during $\overline{\text{RAS}} \leq V_{\text{IL}(\text{MAX.})}$ and $\overline{\text{CAS}} \geq V_{\text{IH}(\text{MIN.})}$.
 - I_{CC3} is measured assuming that all column address inputs are held at either high or low.
 - I_{CC4} is measured assuming that all column address inputs are switched only once during each fast page cycle.

AC Characteristics (Recommended Operating Conditions unless otherwise noted)

AC Characteristics Test Conditions

(1) Input timing specification

(2) Output timing specification

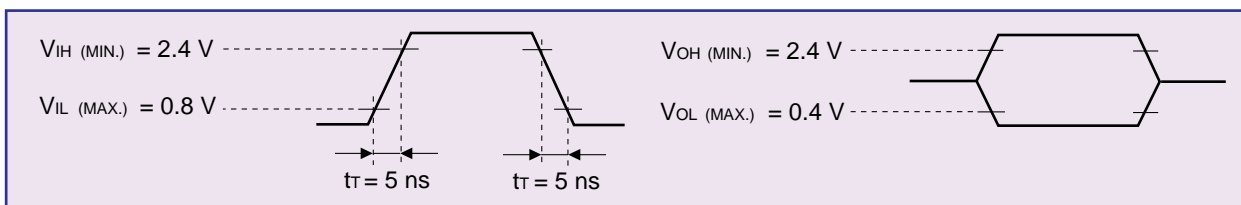

(3) Output load condition

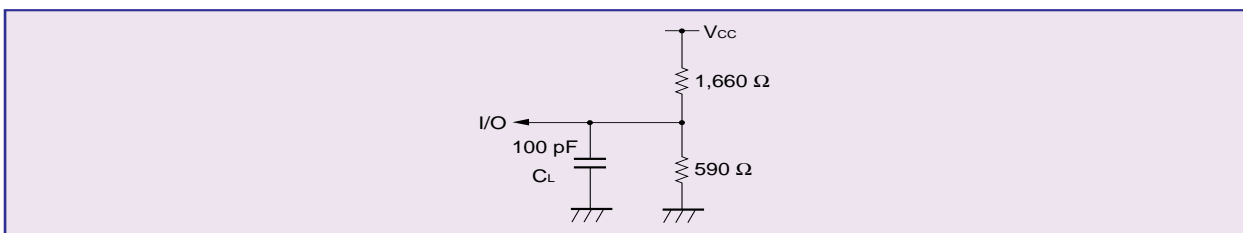

Common to Read, Write, Read Modify Write Cycle

Parameter	Symbol	t _{RAC} = 60 ns		t _{RAC} = 70 ns		t _{RAC} = 80 ns		Unit	Notes	
		MIN.	MAX.	MIN.	MAX.	MIN.	MAX.			
Read/Write cycle time	t _{RC}	110	–	130	–	150	–	ns		
RAS precharge time	t _{RP}	40	–	50	–	60	–	ns		
CAS precharge time	t _{CPN}	10	–	10	–	10	–	ns		
RAS pulse width	t _{RAS}	60	10,000	70	10,000	80	10,000	ns	1	
CAS pulse width	t _{CAS}	15	10,000	20	10,000	20	10,000	ns		
RAS hold time	t _{RSH}	15	–	20	–	20	–	ns		
CAS hold time	t _{CSH}	60	–	70	–	80	–	ns		
RAS to CAS delay time	t _{RCD}	20	45	20	50	20	60	ns	2	
RAS to column address delay time	t _{RAD}	15	30	15	35	15	40	ns	2	
CAS to RAS precharge time	t _{CRP}	10	–	10	–	10	–	ns	3	
Row address setup time	t _{ASR}	0	–	0	–	0	–	ns		
Row address hold time	t _{RAH}	10	–	10	–	10	–	ns		
Column address setup time	t _{ASC}	0	–	0	–	0	–	ns		
Column address hold time	t _{CAH}	15	–	15	–	15	–	ns		
OE lead time referenced to RAS	t _{OES}	0	–	0	–	0	–	ns		
CAS to data setup time	t _{CLZ}	0	–	0	–	0	–	ns		
OE to data setup time	t _{OLZ}	0	–	0	–	0	–	ns		
OE to data delay time	t _{OED}	15	–	15	–	20	–	ns		
Masked byte write hold time referenced to RAS	t _{MRH}	0	–	0	–	0	–	ns		
Transition time (rise and fall)	t _T	3	50	3	50	3	50	ns		
Refresh time	μPD42S4260	t _{REF}	–	128	–	128	–	128	ms	4
	μPD424260	t _{REF}	–	8	–	8	–	8	ms	

- Notes 1.** In $\overline{\text{CAS}}$ before $\overline{\text{RAS}}$ refresh cycles, $t_{\text{RAS}}(\text{MAX.})$ is 100 μs.
 If $10 \mu\text{s} < t_{\text{RAS}} < 100 \mu\text{s}$, $\overline{\text{RAS}}$ precharge time for $\overline{\text{CAS}}$ before $\overline{\text{RAS}}$ self refresh (t_{RPS}) is applied.
- 2.** For read cycles, access time is defined as follows:

Input conditions	Access time	Access time from $\overline{\text{RAS}}$
$t_{\text{RAD}} \leq t_{\text{RAD}}(\text{MAX.})$ and $t_{\text{RCD}} \leq t_{\text{RCD}}(\text{MAX.})$	$t_{\text{RAC}}(\text{MAX.})$	$t_{\text{RAC}}(\text{MAX.})$
$t_{\text{RAD}} > t_{\text{RAD}}(\text{MAX.})$ and $t_{\text{RCD}} \leq t_{\text{RCD}}(\text{MAX.})$	$t_{\text{AA}}(\text{MAX.})$	$t_{\text{RAD}} + t_{\text{AA}}(\text{MAX.})$
$t_{\text{RCD}} > t_{\text{RCD}}(\text{MAX.})$	$t_{\text{CAC}}(\text{MAX.})$	$t_{\text{RCD}} + t_{\text{CAC}}(\text{MAX.})$

$t_{\text{RAD}}(\text{MAX.})$ and $t_{\text{RCD}}(\text{MAX.})$ are specified as reference points only; they are not restrictive operating parameters. They are used to determine which access time (t_{RAC} , t_{AA} or t_{CAC}) is to be used for finding out when output data will be available. Therefore, the input conditions $t_{\text{RAD}} \geq t_{\text{RAD}}(\text{MAX.})$ and $t_{\text{RCD}} \geq t_{\text{RCD}}(\text{MAX.})$ will not cause any operation problems.

- 3.** $t_{\text{CRP}}(\text{MIN.})$ requirement is applied to $\overline{\text{RAS}}$, $\overline{\text{CAS}}$ cycles.
- 4.** This specification is applied only to the μPD42S4260.

Read Cycle

Parameter	Symbol	$t_{\text{RAC}} = 60 \text{ ns}$		$t_{\text{RAC}} = 70 \text{ ns}$		$t_{\text{RAC}} = 80 \text{ ns}$		Unit	Notes
		MIN.	MAX.	MIN.	MAX.	MIN.	MAX.		
Access time from $\overline{\text{RAS}}$	t_{RAC}	–	60	–	70	–	80	ns	1
Access time from $\overline{\text{CAS}}$	t_{CAC}	–	15	–	20	–	20	ns	1
Access time from column address	t_{AA}	–	30	–	35	–	40	ns	1
Access time from $\overline{\text{OE}}$	t_{OEA}	–	15	–	20	–	20	ns	
Column address lead time referenced to $\overline{\text{RAS}}$	t_{RAL}	30	–	35	–	40	–	ns	
Read command setup time	t_{RCS}	0	–	0	–	0	–	ns	
Read command hold time referenced to $\overline{\text{RAS}}$	t_{RRH}	0	–	0	–	0	–	ns	2
Read command hold time referenced to $\overline{\text{CAS}}$	t_{RCH}	0	–	0	–	0	–	ns	2
Output buffer turn-off delay time from $\overline{\text{OE}}$	t_{OEZ}	0	15	0	15	0	20	ns	3
Output buffer turn-off delay time from $\overline{\text{CAS}}$	t_{OFF}	0	15	0	15	0	20	ns	3

- Notes 1.** For read cycles, access time is defined as follows:

Input conditions	Access time	Access time from $\overline{\text{RAS}}$
$t_{\text{RAD}} \leq t_{\text{RAD}}(\text{MAX.})$ and $t_{\text{RCD}} \leq t_{\text{RCD}}(\text{MAX.})$	$t_{\text{RAC}}(\text{MAX.})$	$t_{\text{RAC}}(\text{MAX.})$
$t_{\text{RAD}} > t_{\text{RAD}}(\text{MAX.})$ and $t_{\text{RCD}} \leq t_{\text{RCD}}(\text{MAX.})$	$t_{\text{AA}}(\text{MAX.})$	$t_{\text{RAD}} + t_{\text{AA}}(\text{MAX.})$
$t_{\text{RCD}} > t_{\text{RCD}}(\text{MAX.})$	$t_{\text{CAC}}(\text{MAX.})$	$t_{\text{RCD}} + t_{\text{CAC}}(\text{MAX.})$

$t_{\text{RAD}}(\text{MAX.})$ and $t_{\text{RCD}}(\text{MAX.})$ are specified as reference points only; they are not restrictive operating parameters. They are used to determine which access time (t_{RAC} , t_{AA} or t_{CAC}) is to be used for finding out when output data will be available. Therefore, the input conditions $t_{\text{RAD}} \geq t_{\text{RAD}}(\text{MAX.})$ and $t_{\text{RCD}} \geq t_{\text{RCD}}(\text{MAX.})$ will not cause any operation problems.

- 2.** Either $t_{\text{RCH}}(\text{MIN.})$ or $t_{\text{RRH}}(\text{MIN.})$ should be met in read cycles.
- 3.** $t_{\text{OFF}}(\text{MAX.})$ and $t_{\text{OEZ}}(\text{MAX.})$ define the time when the output achieves the condition of Hi-Z and is not referenced to V_{OH} or V_{OL} .

Write Cycle

Parameter	Symbol	t _{RAC} = 60 ns		t _{RAC} = 70 ns		t _{RAC} = 80 ns		Unit	Notes
		MIN.	MAX.	MIN.	MAX.	MIN.	MAX.		
\overline{WE} hold time referenced to \overline{CAS}	t _{WCH}	15	–	15	–	15	–	ns	1
\overline{WE} pulse width	t _{WP}	10	–	15	–	15	–	ns	1
\overline{WE} lead time referenced to \overline{RAS}	t _{RWL}	15	–	20	–	20	–	ns	
\overline{WE} lead time referenced to \overline{CAS}	t _{CWL}	15	–	15	–	20	–	ns	
\overline{WE} setup time	t _{WCS}	0	–	0	–	0	–	ns	2
OE hold time	t _{OEH}	0	–	0	–	0	–	ns	
Data-in setup time	t _{DS}	0	–	0	–	0	–	ns	3
Data-in hold time	t _{DH}	15	–	15	–	20	–	ns	3

- Notes**
1. t_{WP} (MIN.) is applied to late write cycles or read modify write cycles. In early write cycles, t_{WCH} (MIN.) should be met.
 2. If t_{WCS} ≥ t_{WCS} (MIN.), the cycle is an early write cycle and the data out will remain Hi-Z through the entire cycle.
 3. t_{DS} (MIN.) and t_{DH} (MIN.) are referenced to the \overline{CAS} falling edge in early write cycles. In late write cycles and read modify write cycles, they are referenced to the \overline{WE} falling edge.

Read Modify Write Cycle

Parameter	Symbol	t _{RAC} = 60 ns		t _{RAC} = 70 ns		t _{RAC} = 80 ns		Unit	Note
		MIN.	MAX.	MIN.	MAX.	MIN.	MAX.		
Read modify write cycle time	t _{RWC}	150	–	175	–	200	–	ns	
\overline{RAS} to \overline{WE} delay time	t _{RWD}	80	–	90	–	105	–	ns	1
\overline{CAS} to \overline{WE} delay time	t _{CWD}	35	–	40	–	45	–	ns	1
Column address to \overline{WE} delay time	t _{AWD}	50	–	55	–	65	–	ns	1

- Note 1.** If t_{WCS} ≥ t_{WCS} (MIN.), the cycle is an early write cycle and the data out will remain Hi-Z through the entire cycle. If t_{RWD} ≥ t_{RWD} (MIN.), t_{CWD} ≥ t_{CWD} (MIN.), t_{AWD} ≥ t_{AWD} (MIN.) and t_{CPWD} ≥ t_{CPWD} (MIN.), the cycle is a read modify write cycle and the data out will contain data read from the selected cell. If neither of the above conditions is met, the state of the data out is indeterminate.

Fast Page Mode

Parameter	Symbol	t _{RAC} = 60 ns		t _{RAC} = 70 ns		t _{RAC} = 80 ns		Unit	Note
		MIN.	MAX.	MIN.	MAX.	MIN.	MAX.		
Fast page mode cycle time	t _{PC}	40	–	45	–	50	–	ns	
Access time from $\overline{\text{CAS}}$ precharge	t _{ACP}	–	35	–	40	–	45	ns	
$\overline{\text{RAS}}$ pulse width	t _{RASP}	60	125,000	70	125,000	80	125,000	ns	
$\overline{\text{CAS}}$ precharge time	t _{CP}	10	–	10	–	10	–	ns	
$\overline{\text{RAS}}$ hold time from $\overline{\text{CAS}}$ precharge	t _{RHCP}	35	–	40	–	45	–	ns	
Read modify write cycle time	t _{PRWC}	80	–	85	–	100	–	ns	
$\overline{\text{CAS}}$ precharge to $\overline{\text{WE}}$ delay time	t _{CPWD}	55	–	60	–	70	–	ns	1

Note 1. If $t_{\text{WCS}} \geq t_{\text{WCS}}(\text{MIN.})$, the cycle is an early write cycle and the data out will remain Hi-Z through the entire cycle. If $t_{\text{RWD}} \geq t_{\text{RWD}}(\text{MIN.})$, $t_{\text{CWD}} \geq t_{\text{CWD}}(\text{MIN.})$, $t_{\text{AWD}} \geq t_{\text{AWD}}(\text{MIN.})$ and $t_{\text{CPWD}} \geq t_{\text{CPWD}}(\text{MIN.})$, the cycle is a read modify write cycle and the data out will contain data read from the selected cell. If neither of the above conditions is met, the state of the data out is indeterminate.

Refresh Cycle

Parameter	Symbol	t _{RAC} = 60 ns		t _{RAC} = 70 ns		t _{RAC} = 80 ns		Unit	Note
		MIN.	MAX.	MIN.	MAX.	MIN.	MAX.		
$\overline{\text{CAS}}$ setup time	t _{CSR}	10	–	10	–	10	–	ns	
$\overline{\text{CAS}}$ hold time ($\overline{\text{CAS}}$ before $\overline{\text{RAS}}$ refresh)	t _{CHR}	10	–	15	–	15	–	ns	
$\overline{\text{RAS}}$ precharge $\overline{\text{CAS}}$ hold time	t _{RPC}	10	–	10	–	10	–	ns	
$\overline{\text{RAS}}$ pulse width ($\overline{\text{CAS}}$ before $\overline{\text{RAS}}$ self refresh cycle)	t _{RASS}	100	–	100	–	100	–	μs	1
$\overline{\text{RAS}}$ precharge time ($\overline{\text{CAS}}$ before $\overline{\text{RAS}}$ self refresh cycle)	t _{RPS}	110	–	130	–	150	–	ns	1
$\overline{\text{CAS}}$ hold time ($\overline{\text{CAS}}$ before $\overline{\text{RAS}}$ self refresh cycle)	t _{CHS}	–50	–	–50	–	–50	–	ns	1
$\overline{\text{WE}}$ hold time (hidden refresh cycle)	t _{WHR}	10	–	15	–	15	–	ns	

Note 1. This specification is applied only to the μPD42S4260.

Read Cycle

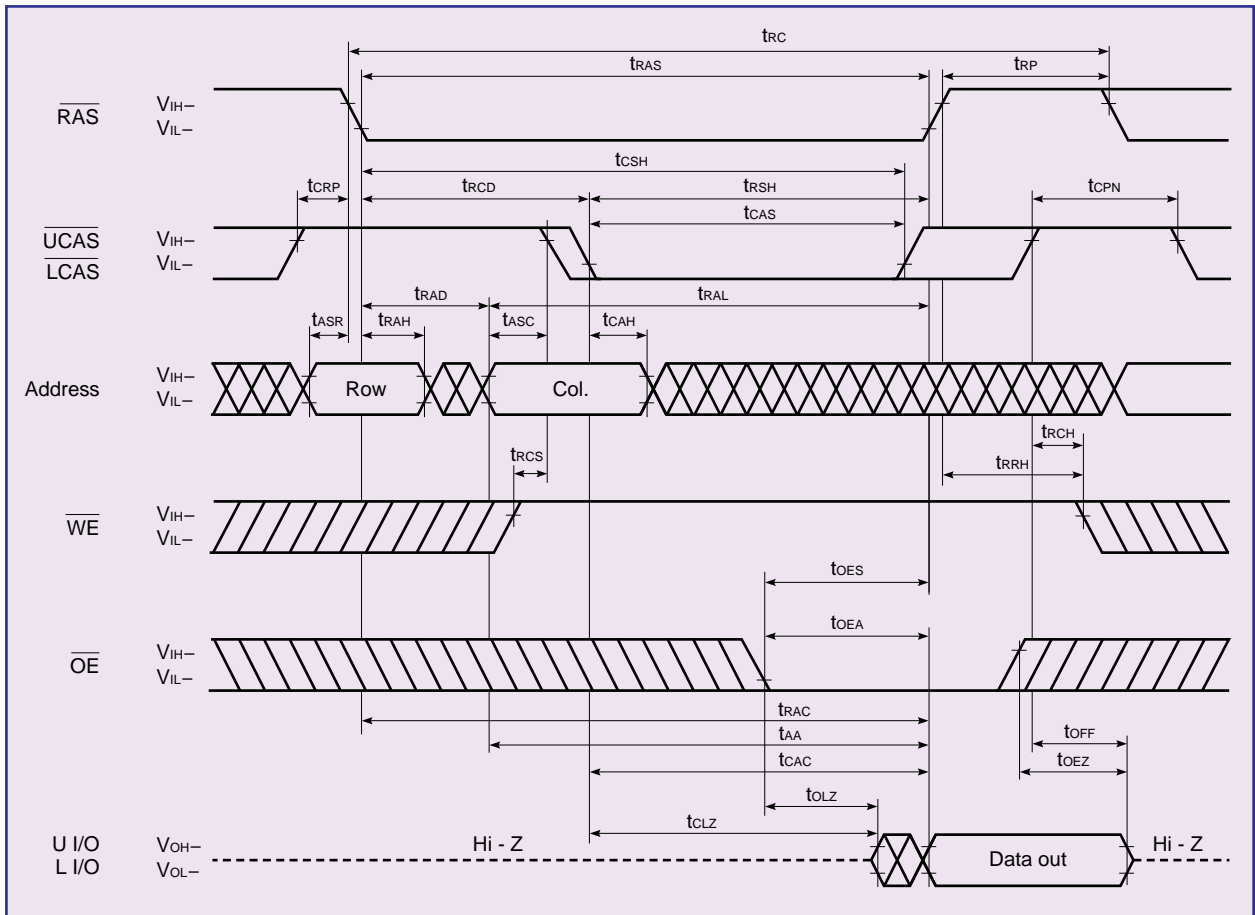

Upper Byte Read Cycle

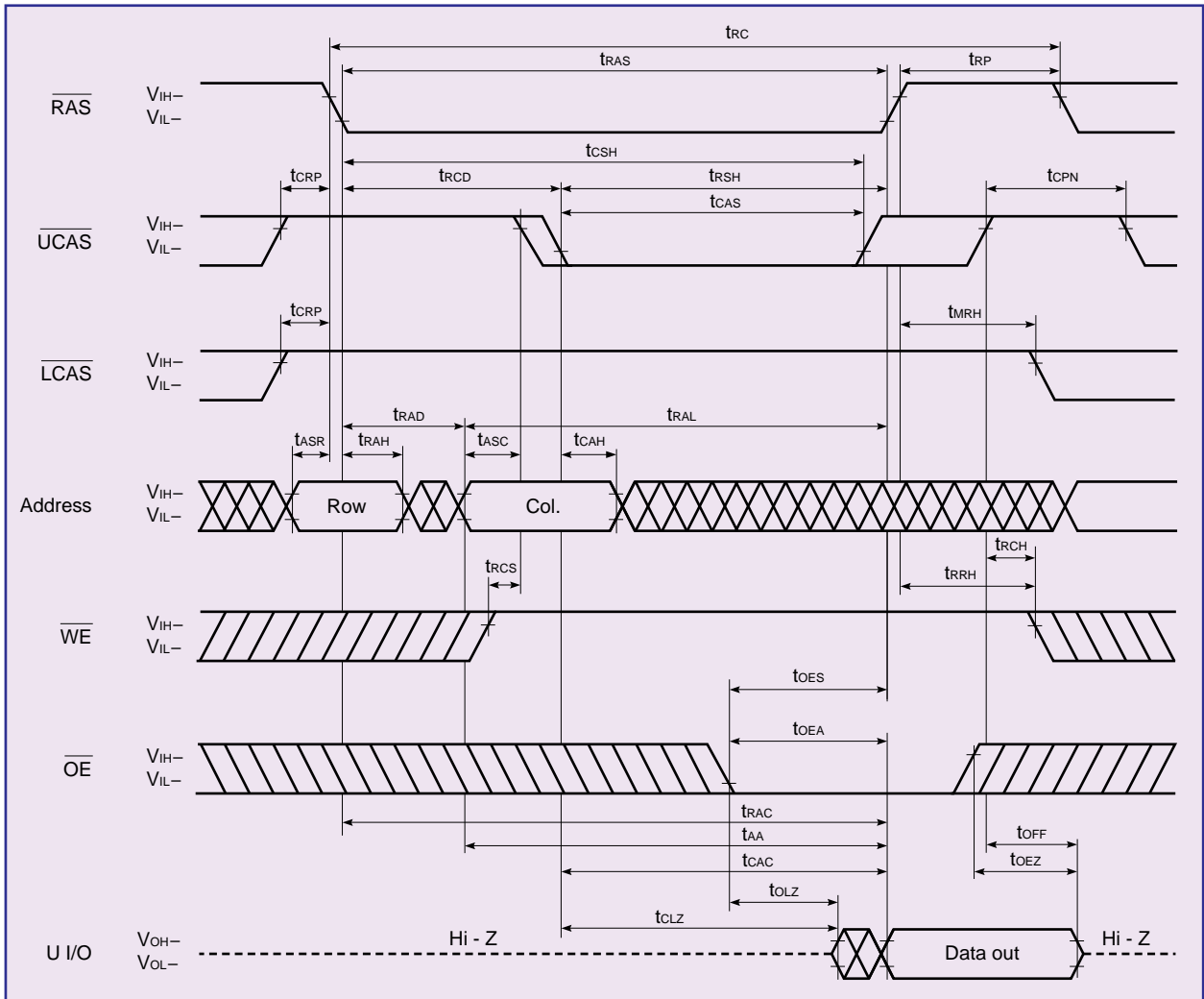

Remark L I/O: Hi-Z

Lower Byte Read Cycle

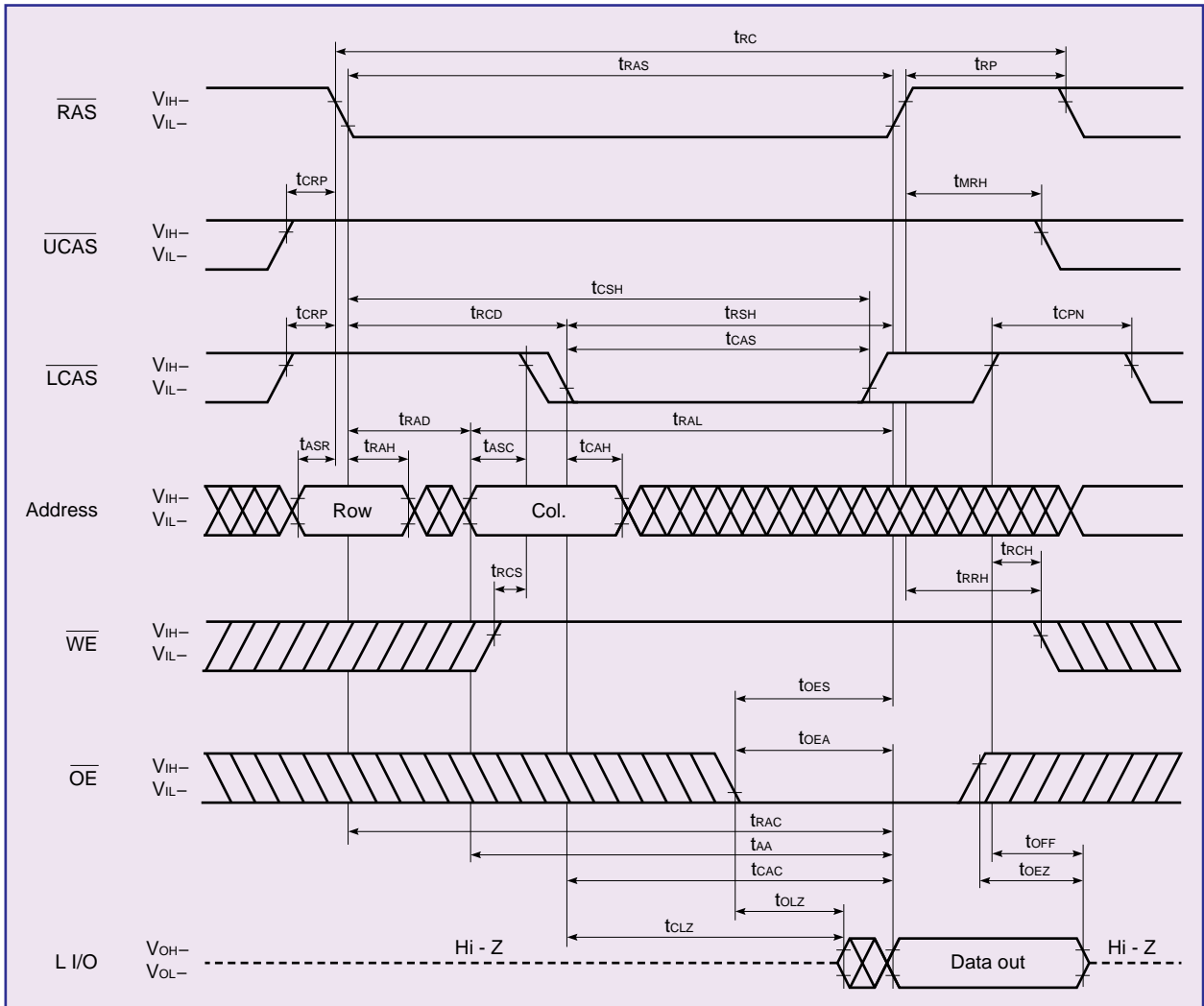

Remark U I/O: Hi-Z

Early Write Cycle

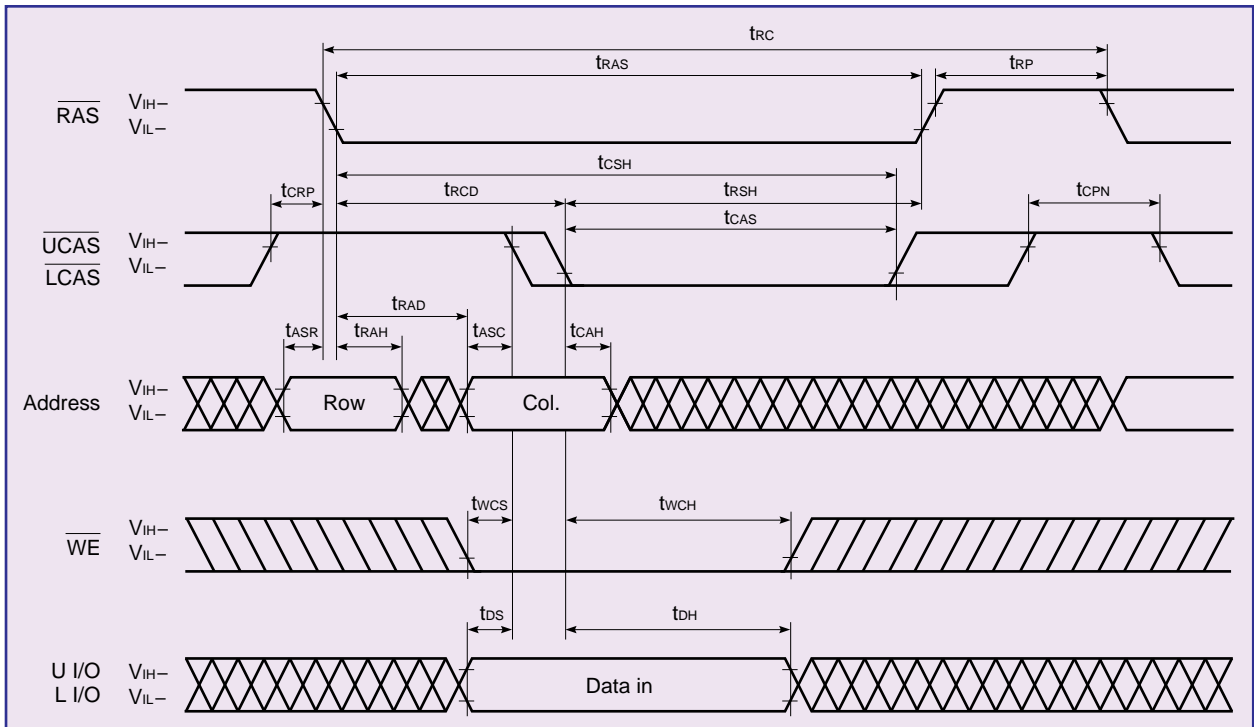

Remark \overline{OE} : Don't care

Upper Byte Early Write Cycle

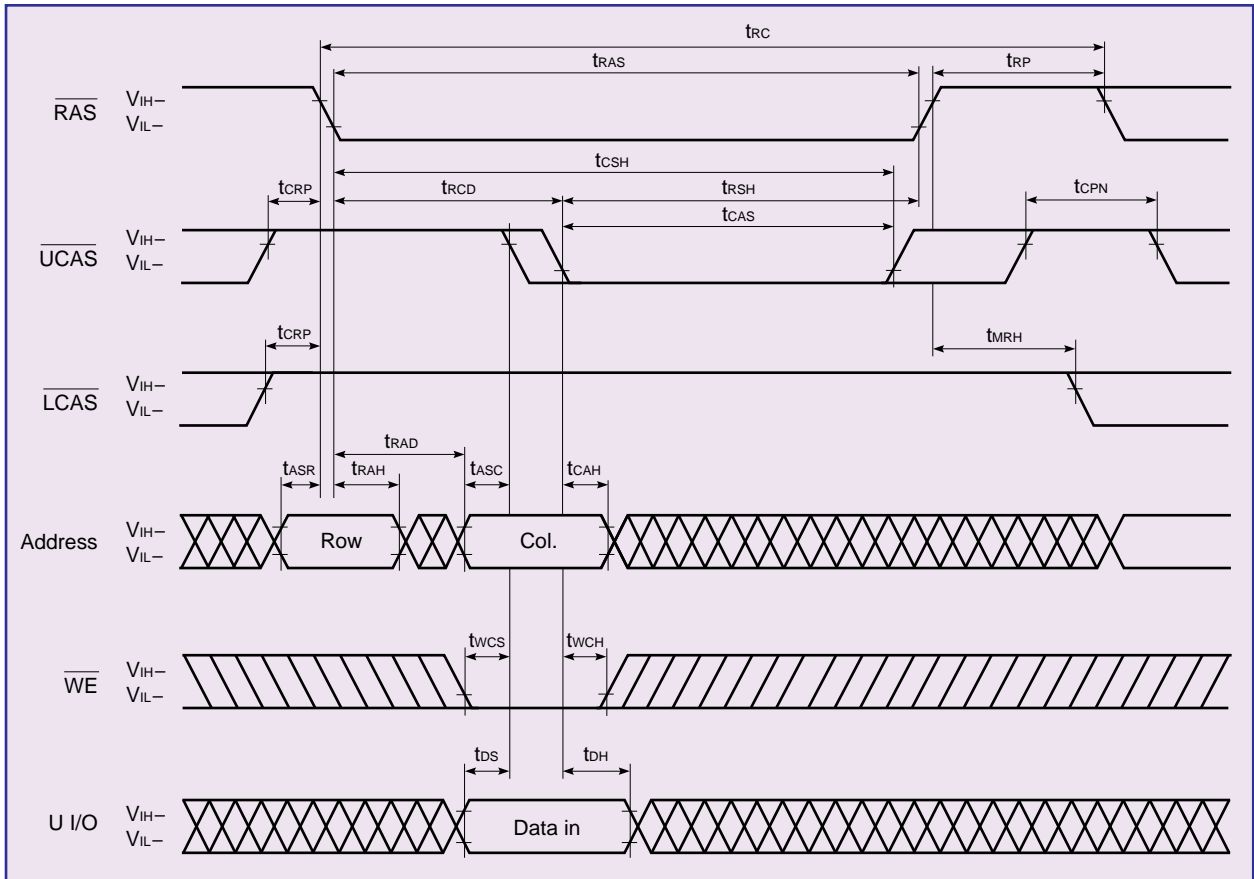

Remark \overline{OE} , L I/O: Don't care

Lower Byte Early Write Cycle

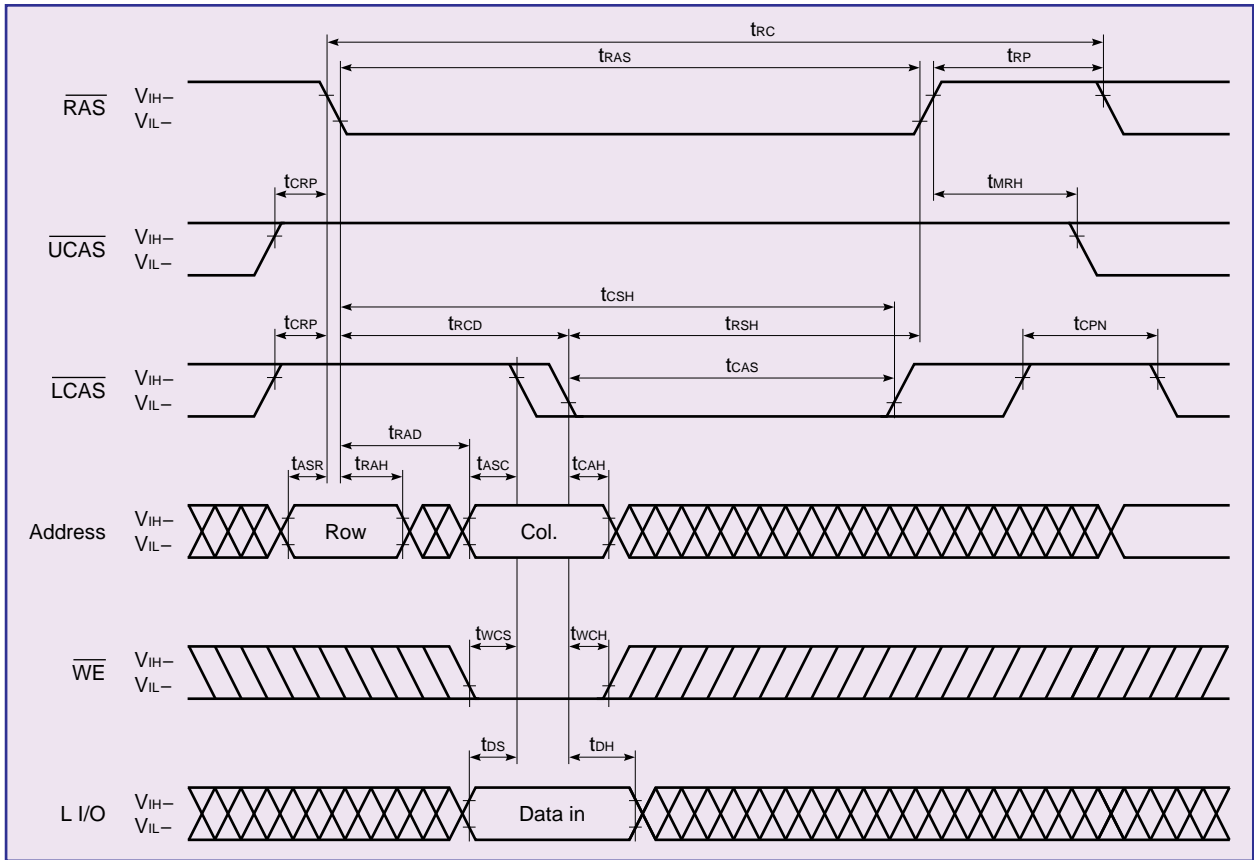

Remark \overline{OE} , U I/O: Don't care

Late Write Cycle

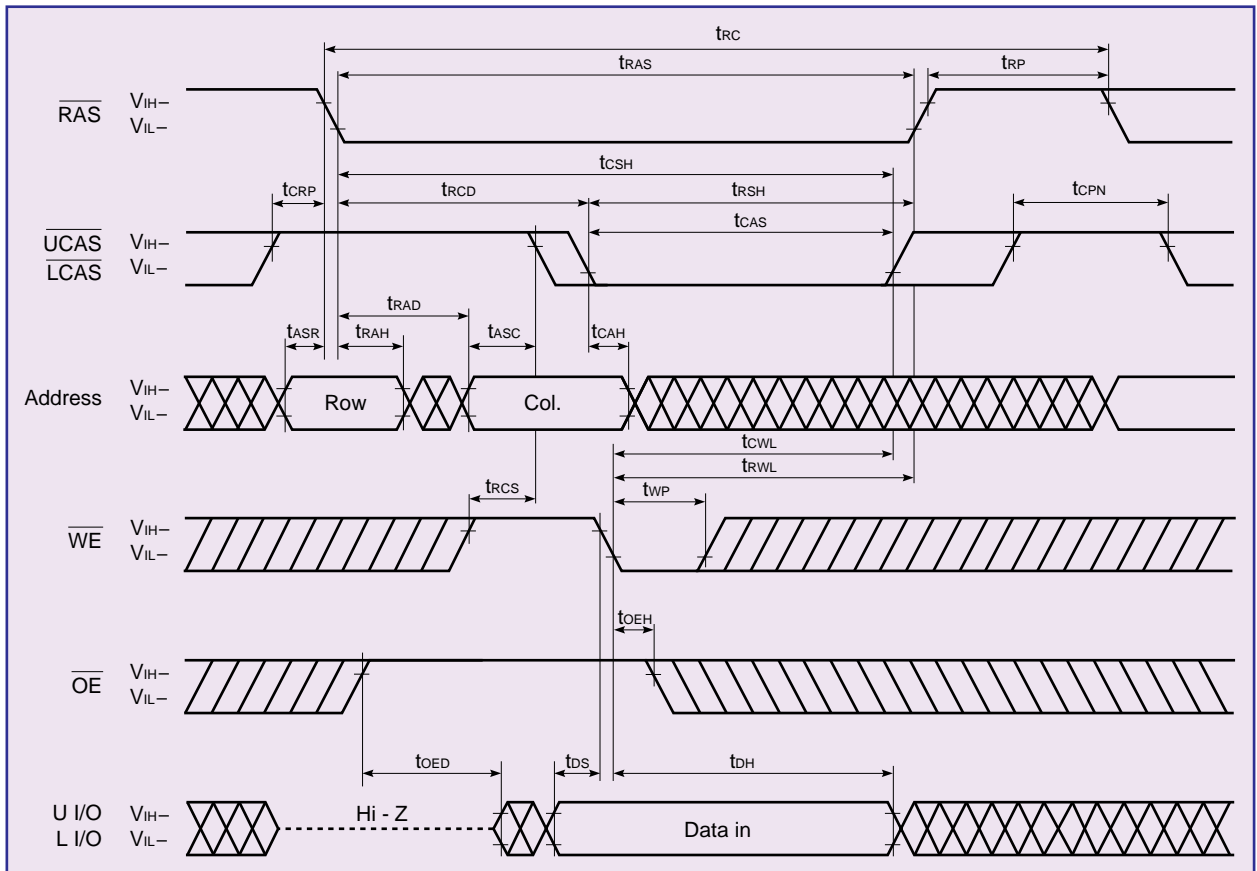

Upper Byte Late Write Cycle

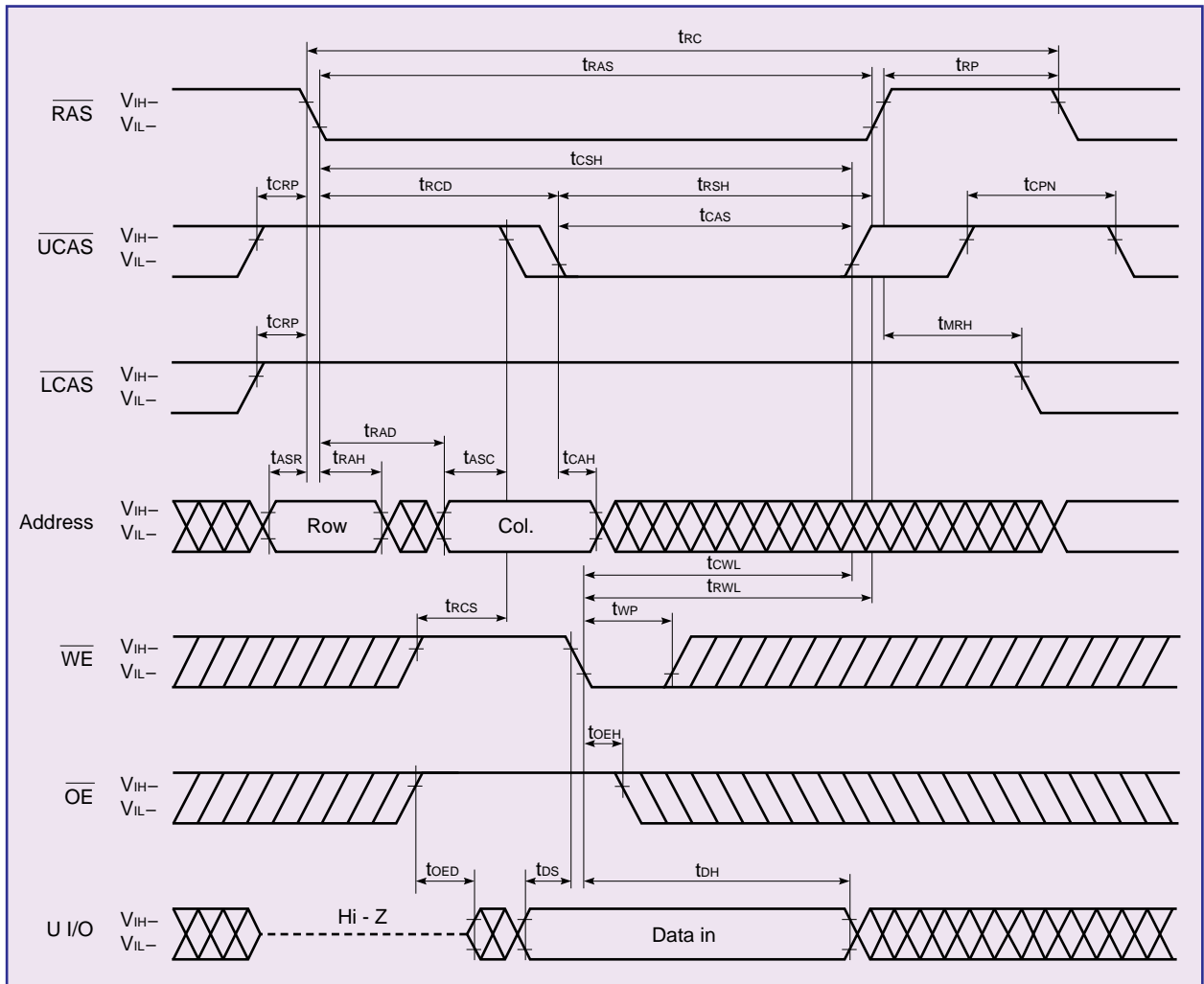

Remark L I/O: Don't care

Lower Byte Late Write Cycle

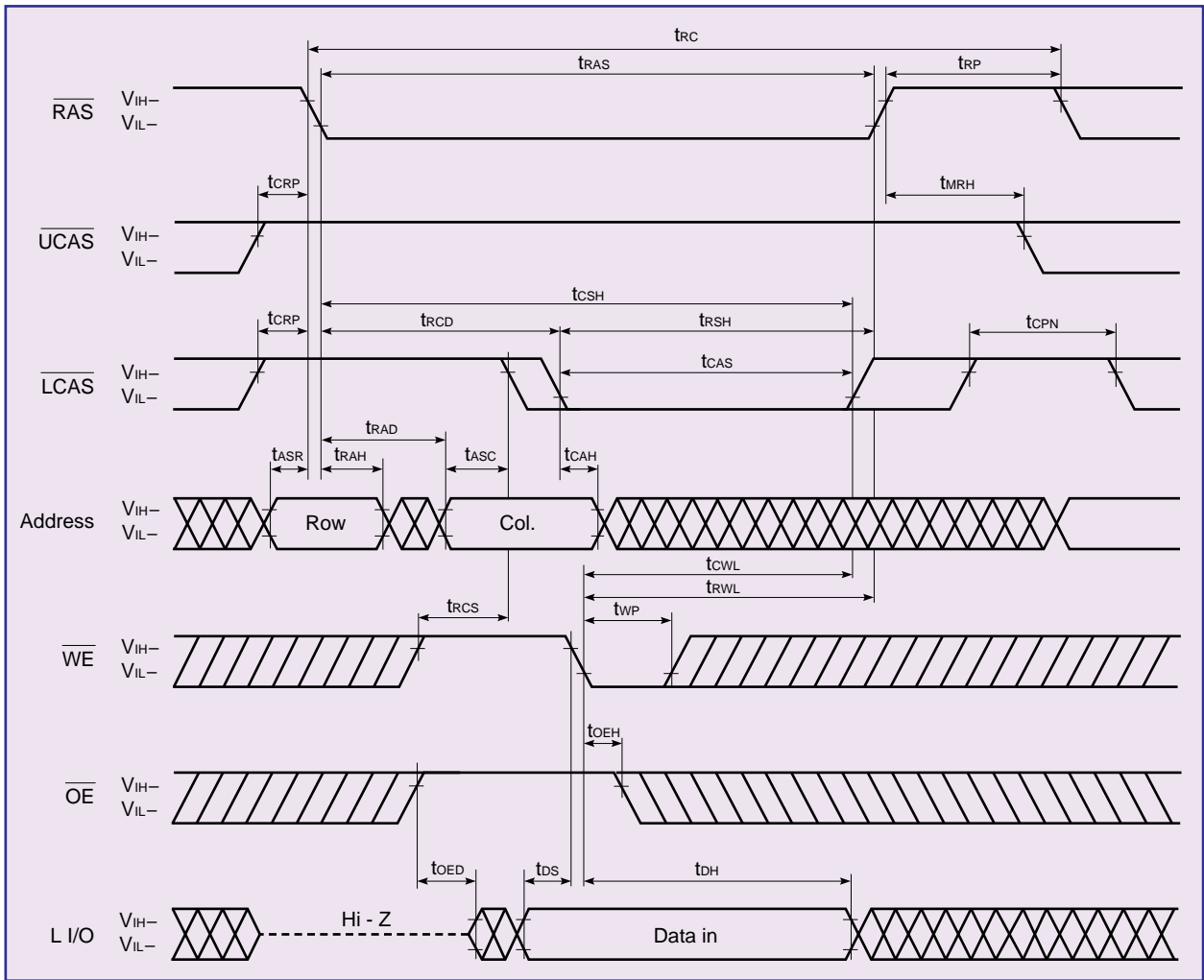

Remark U I/O: Don't care

Read Modify Write Cycle

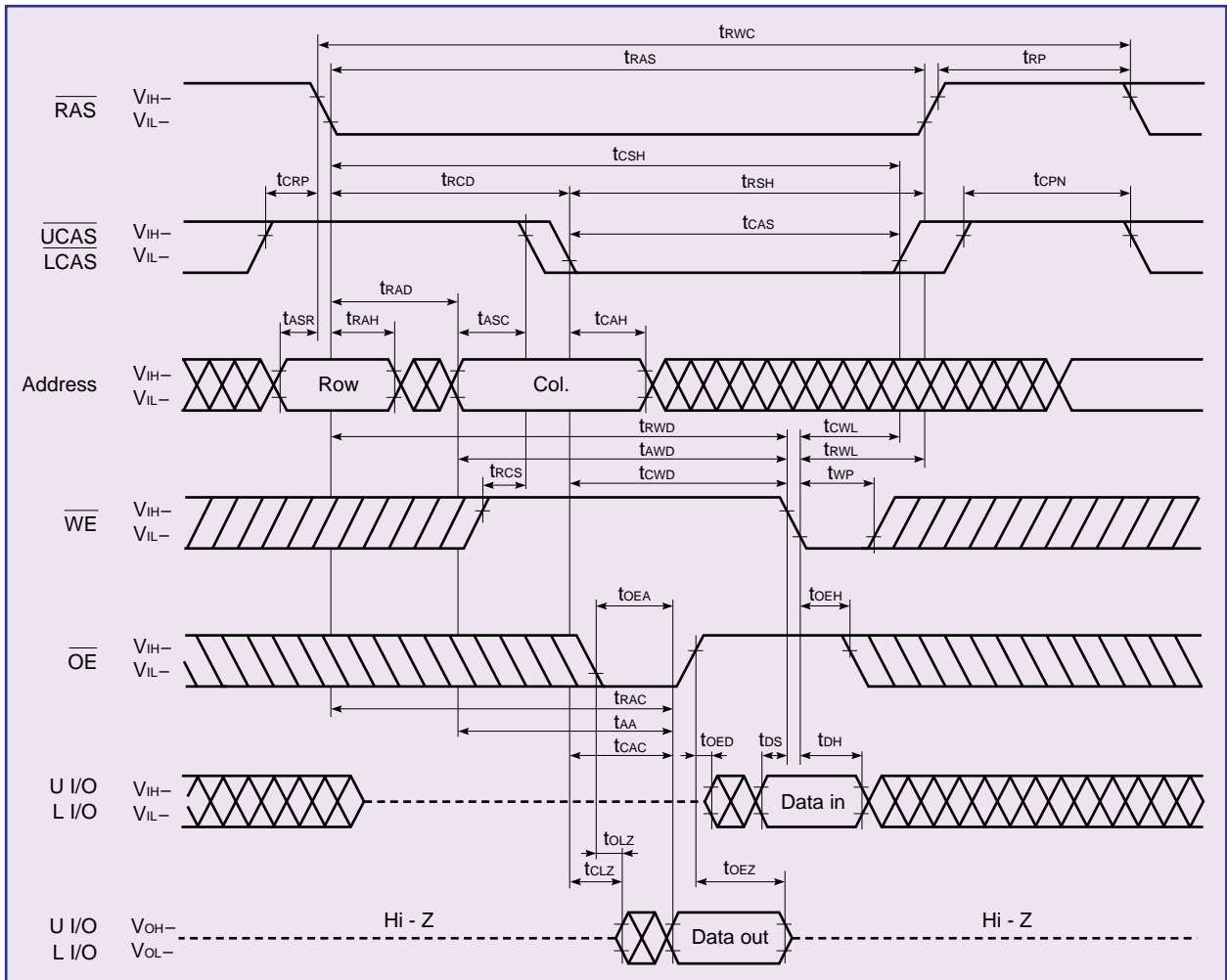

Upper Byte Read Modify Write Cycle

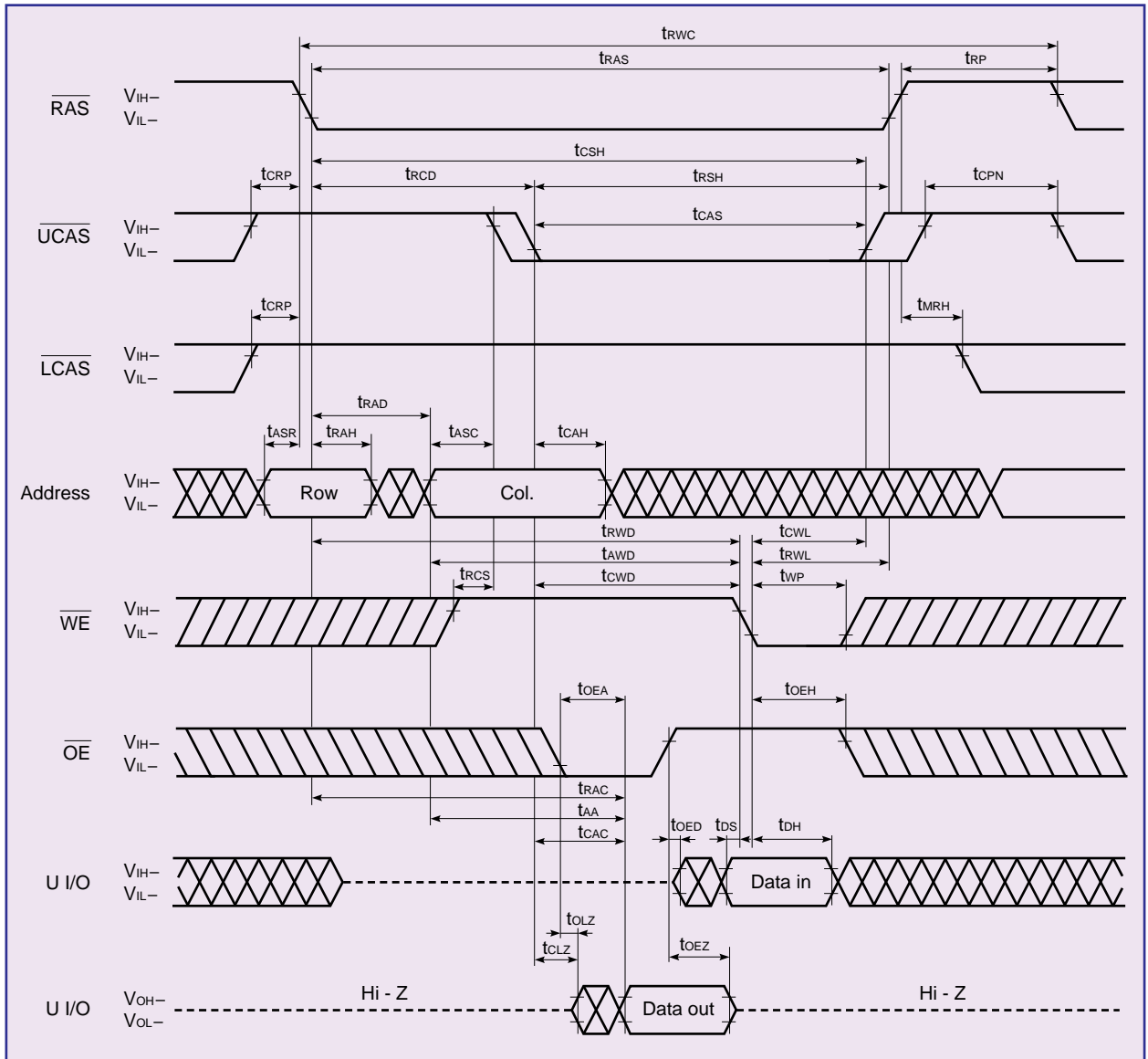

Remark In this cycle, the input data to Lower I/O is ineffective. The data out of that remains Hi-Z.

Lower Byte Read Modify Write Cycle

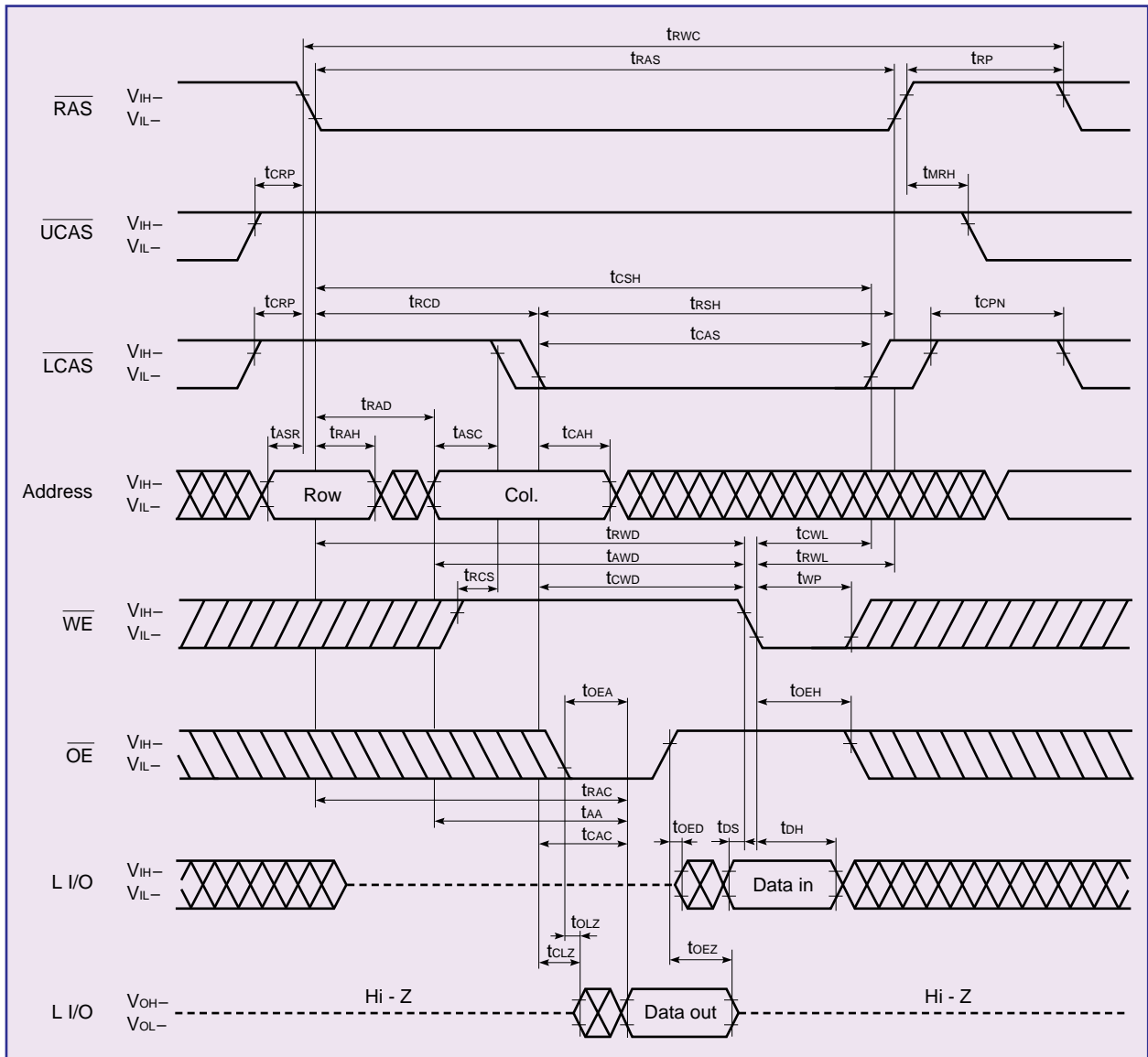

Remark In this cycle, the input data to Upper I/O is ineffective. The data out of that remains Hi-Z.

Fast Page Mode Read Cycle

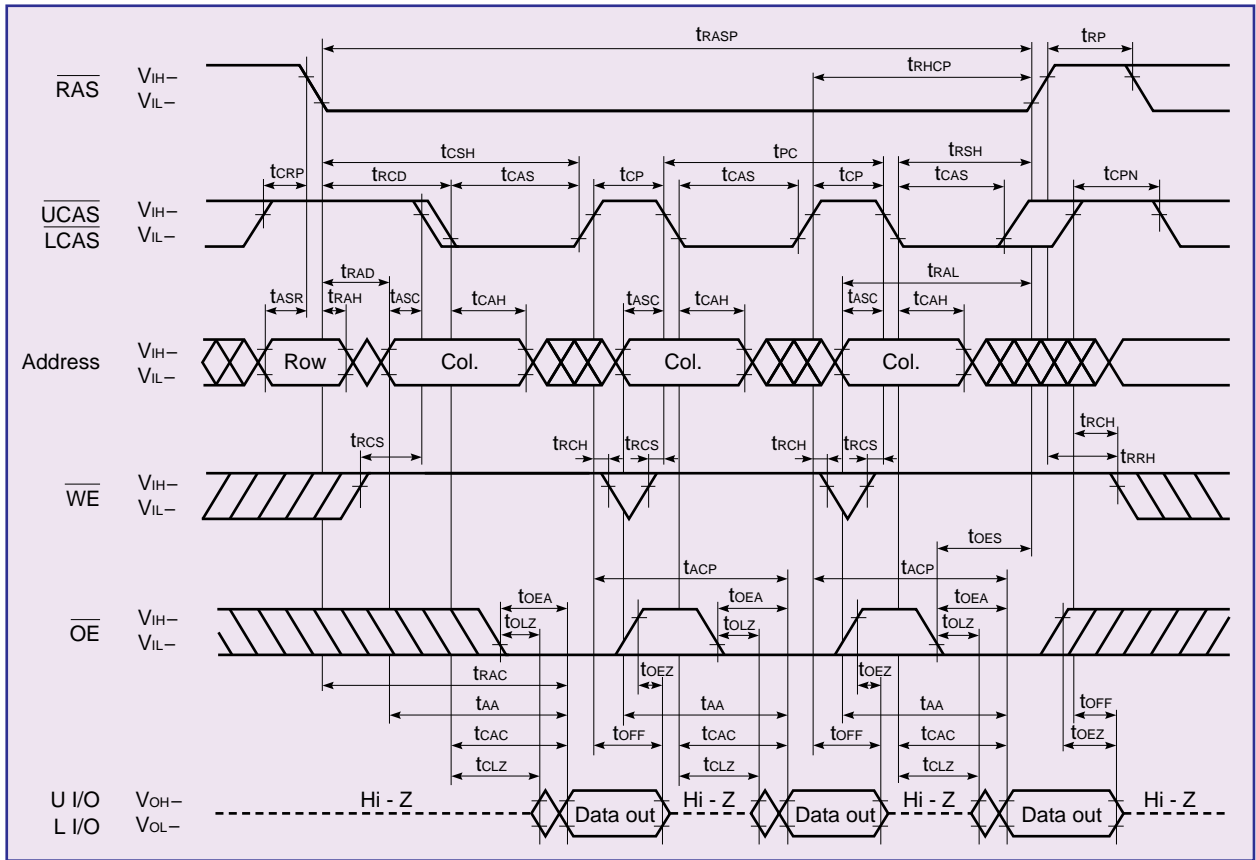

Remark In the fast page mode, read, write and read modify write cycles are available for each of the consecutive $\overline{\text{CAS}}$ cycles within the same $\overline{\text{RAS}}$ cycle.

Fast Page Mode Byte Read Cycle

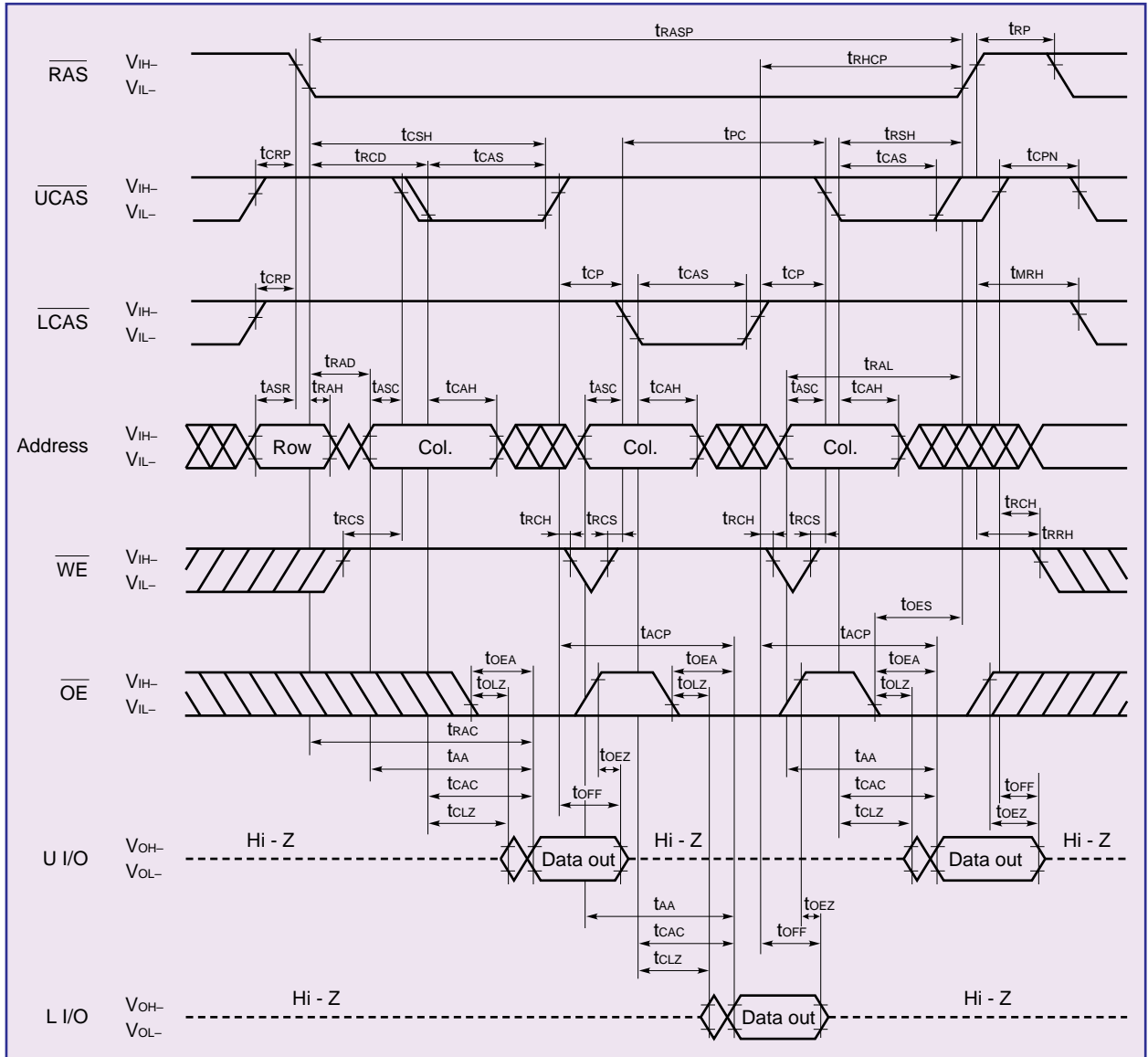

- Remarks 1.** In the fast page mode, read, write and read modify write cycles are available for each of the consecutive $\overline{\text{CAS}}$ cycles within the same $\overline{\text{RAS}}$ cycle.
- 2.** This cycle can be used to control either $\overline{\text{UCAS}}$ or $\overline{\text{LCAS}}$ only. Or, it can be used to control $\overline{\text{UCAS}}$ or $\overline{\text{LCAS}}$ simultaneously, or at random.

Fast Page Mode Early Write Cycle

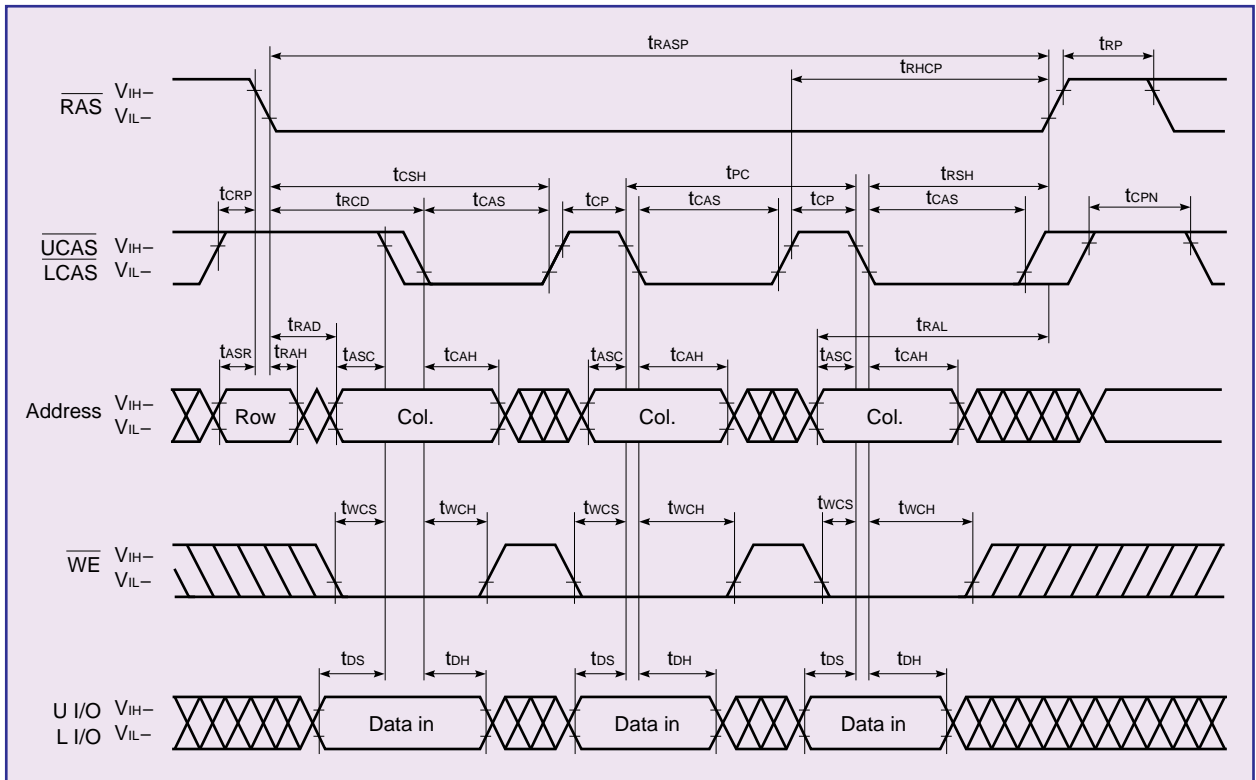

- Remarks**
1. \overline{OE} : Don't care
 2. In the fast page mode, read, write and read modify write cycles are available for each of the consecutive \overline{CAS} cycles within the same \overline{RAS} cycle.

Fast Page Mode Byte Early Write Cycle

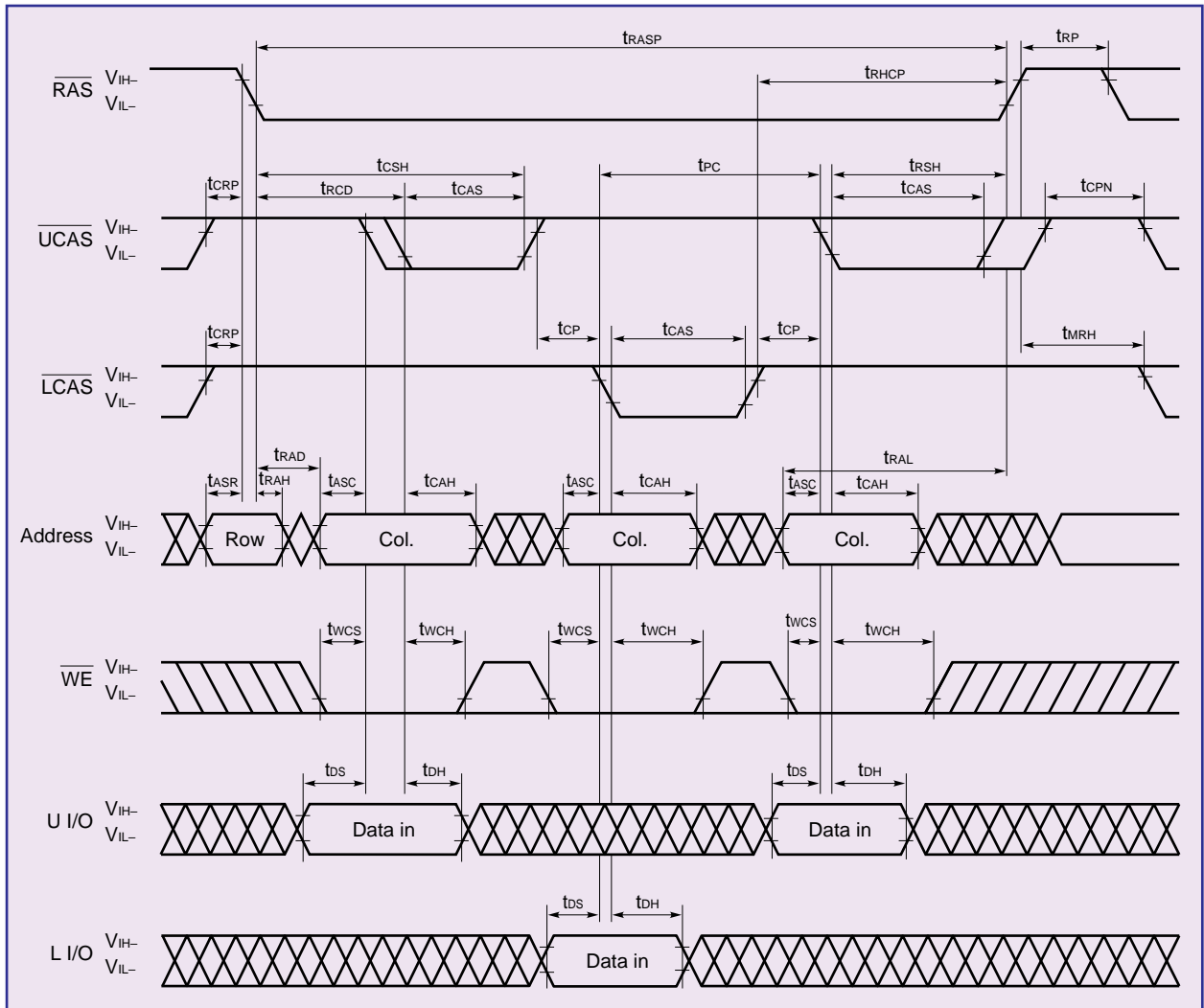

- Remarks**
1. $\overline{\text{OE}}$: Don't care
 2. In the fast page mode, read, write and read modify write cycles are available for each of the consecutive $\overline{\text{CAS}}$ cycles within the same $\overline{\text{RAS}}$ cycle.
 3. This cycle can be used to control either $\overline{\text{UCAS}}$ or $\overline{\text{LCAS}}$ only. Or, it can be used to control $\overline{\text{UCAS}}$ or $\overline{\text{LCAS}}$ simultaneously, or at random.

Fast Page Mode Late Write Cycle

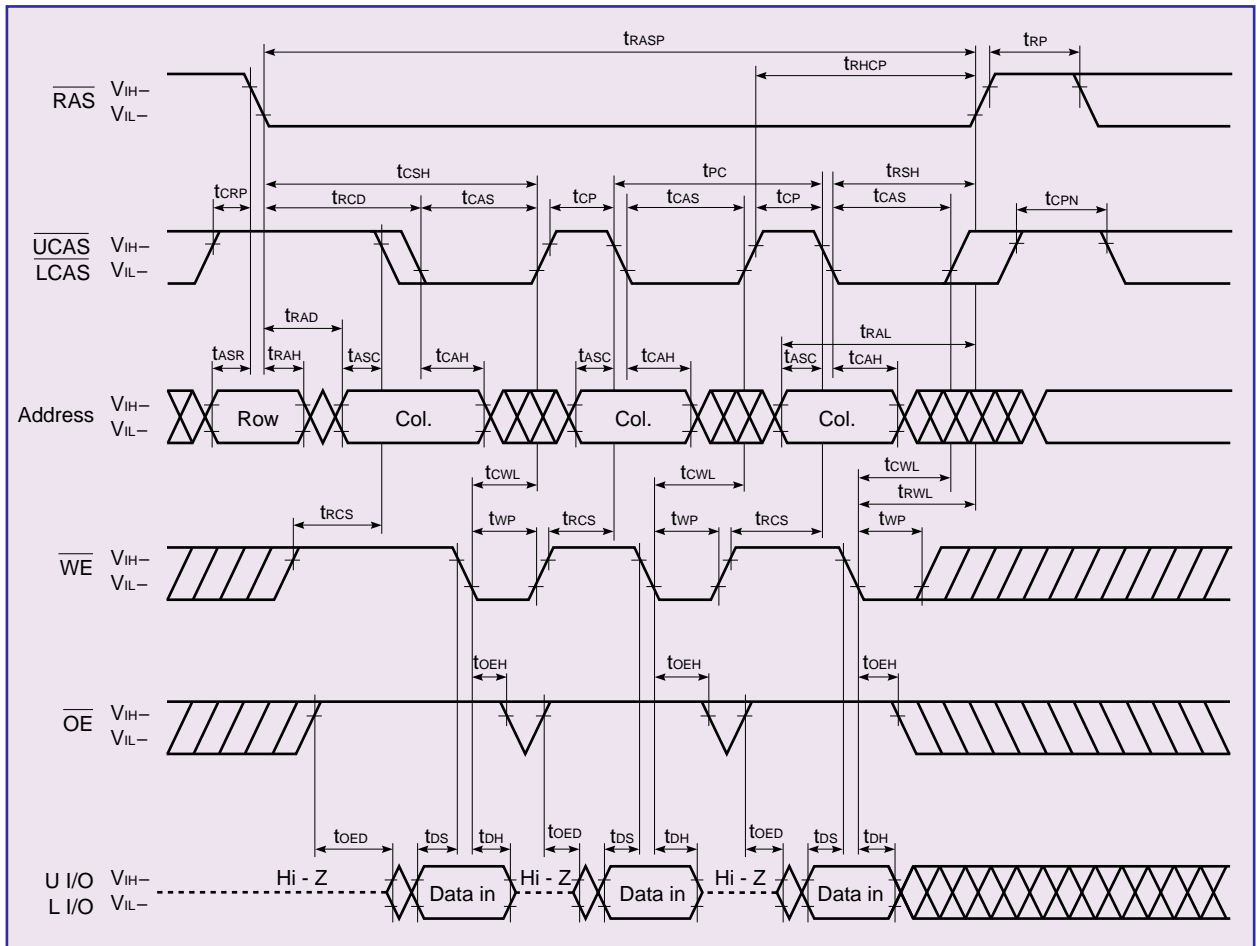

Remark In the fast page mode, read, write and read modify write cycles are available for each of the consecutive CAS cycles within the same RAS cycle.

Fast Page Mode Read Modify Write Cycle

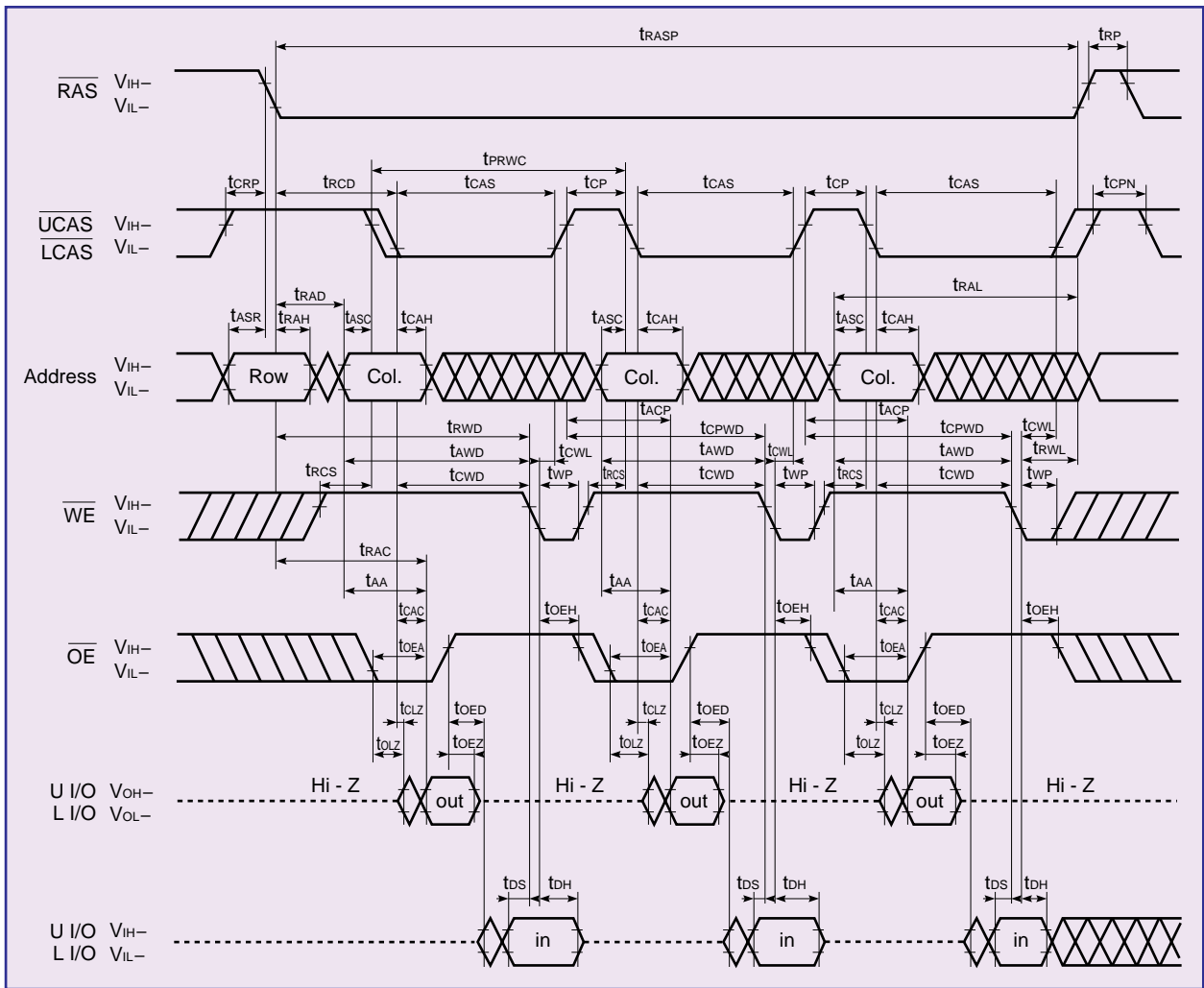

Remark In the fast page mode, read, write and read modify write cycles are available for each of the consecutive CAS cycles within the same RAS cycle.

Fast Page Mode Byte Read Modify Write Cycle

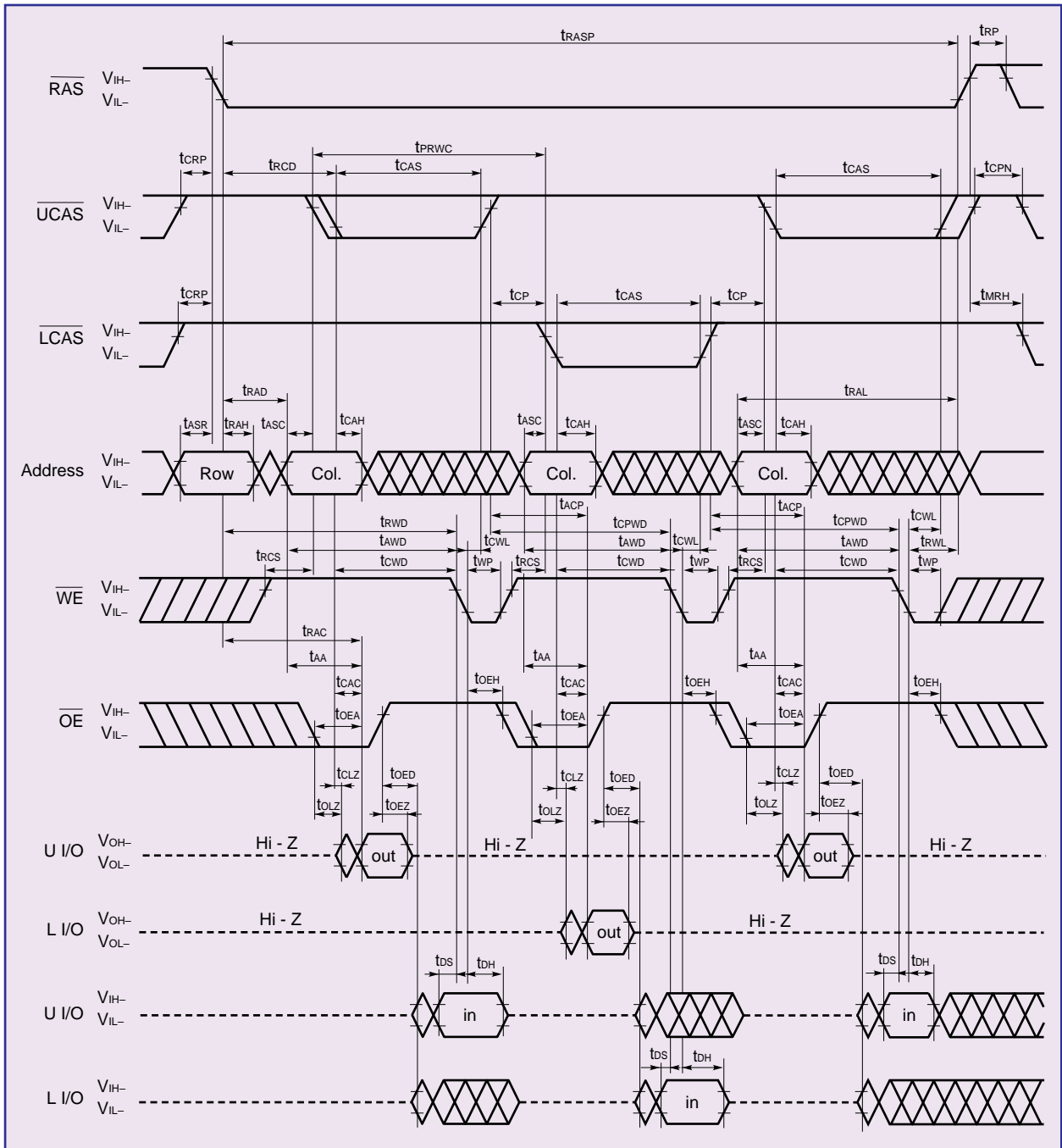

- Remarks 1.** In the fast page mode, read, write and read modify write cycles are available for each of the consecutive CAS cycles within the same RAS cycle.
- 2.** This cycle can be used to control either UCAS or LCAS only. Or, it can be used to control UCAS or LCAS simultaneously, or at random.

CAS Before RAS Self Refresh Cycle (Only for the mPD42S4260)

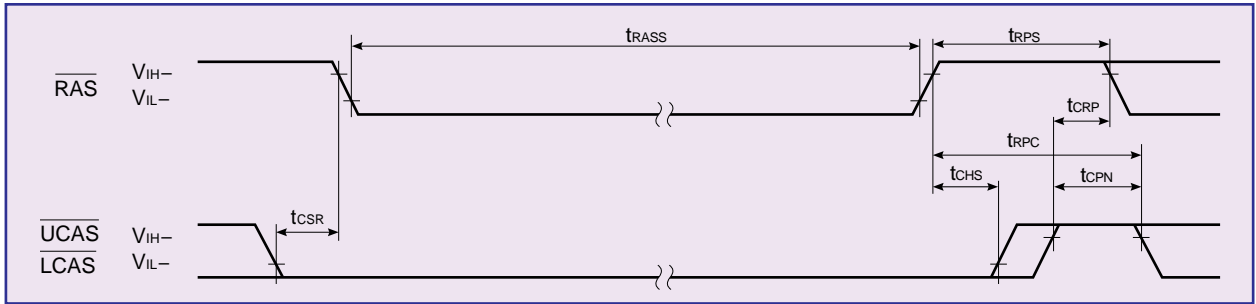

Remark Address, \overline{WE} , \overline{OE} : Don't care L I/O, U I/O: Hi-Z

Cautions on Use of \overline{CAS} Before \overline{RAS} Self Refresh

\overline{CAS} before \overline{RAS} self refresh can be used independently when used in combination with distributed \overline{CAS} before \overline{RAS} long refresh; However, when used in combination with burst \overline{CAS} before \overline{RAS} long refresh or with long \overline{RAS} only refresh (both distributed and burst), the following cautions must be observed.

- (1) **Normal Combined Use of \overline{CAS} Before \overline{RAS} Self Refresh and Burst \overline{CAS} Before \overline{RAS} Long Refresh**
When \overline{CAS} before \overline{RAS} self refresh and burst \overline{CAS} before \overline{RAS} long refresh are used in combination, please perform \overline{CAS} before \overline{RAS} refresh 512 times within an 8 ms interval just before and after setting \overline{CAS} before \overline{RAS} self refresh.
- (2) **Normal Combined Use of \overline{CAS} Before \overline{RAS} Self Refresh and Long \overline{RAS} Only Refresh**
When \overline{CAS} before \overline{RAS} self refresh and \overline{RAS} only refresh are used in combination, please perform \overline{RAS} only refresh 512 times within an 8 ms interval just before and after setting \overline{CAS} before \overline{RAS} self refresh.
- (3) If $t_{RASS(MIN)}$ is not satisfied at the beginning of \overline{CAS} before \overline{RAS} self refresh cycles ($t_{RAS} < 100 \mu s$), \overline{CAS} before \overline{RAS} refresh cycles will be executed one time.
If $10 \mu s < t_{RAS} < 100 \mu s$, RAS precharge time for \overline{CAS} before \overline{RAS} self refresh (t_{RPS}) is applied.
And refresh cycles (512/128 ms) should be met.

For details, please refer to [How to use DRAM User's Manual](#).

CAS Before RAS Refresh Cycle

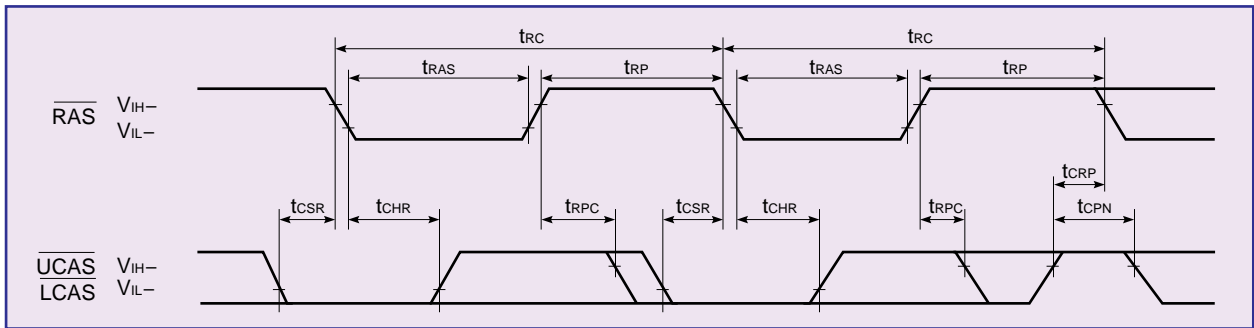

Remark Address, \overline{WE} , \overline{OE} : Don't care L I/O, U I/O: Hi-Z

RAS Only Refresh Cycle

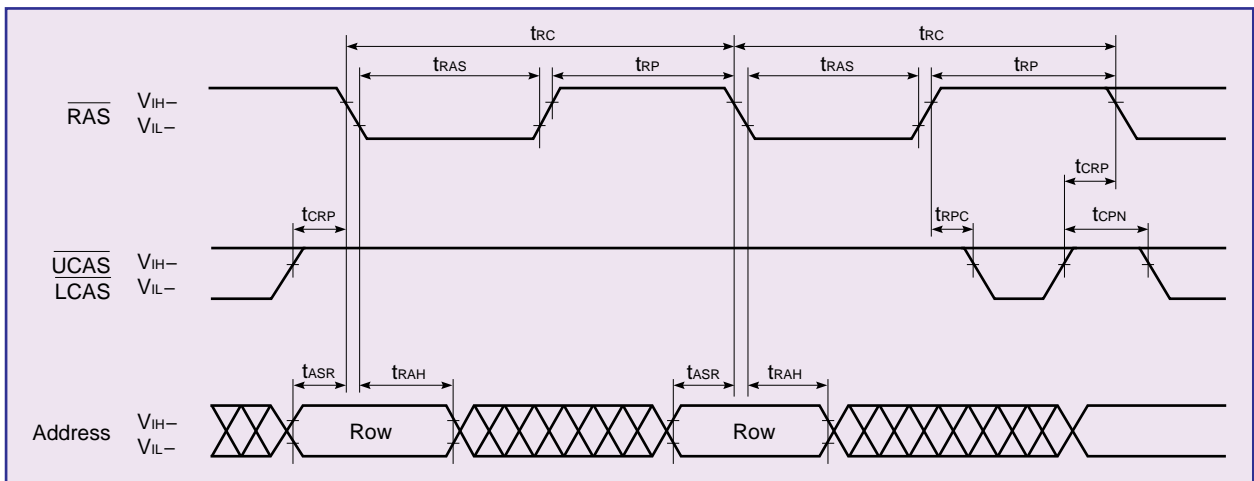

Remark \overline{WE} , \overline{OE} : Don't care L I/O, U I/O: Hi-Z

Hidden Refresh Cycle (Read)

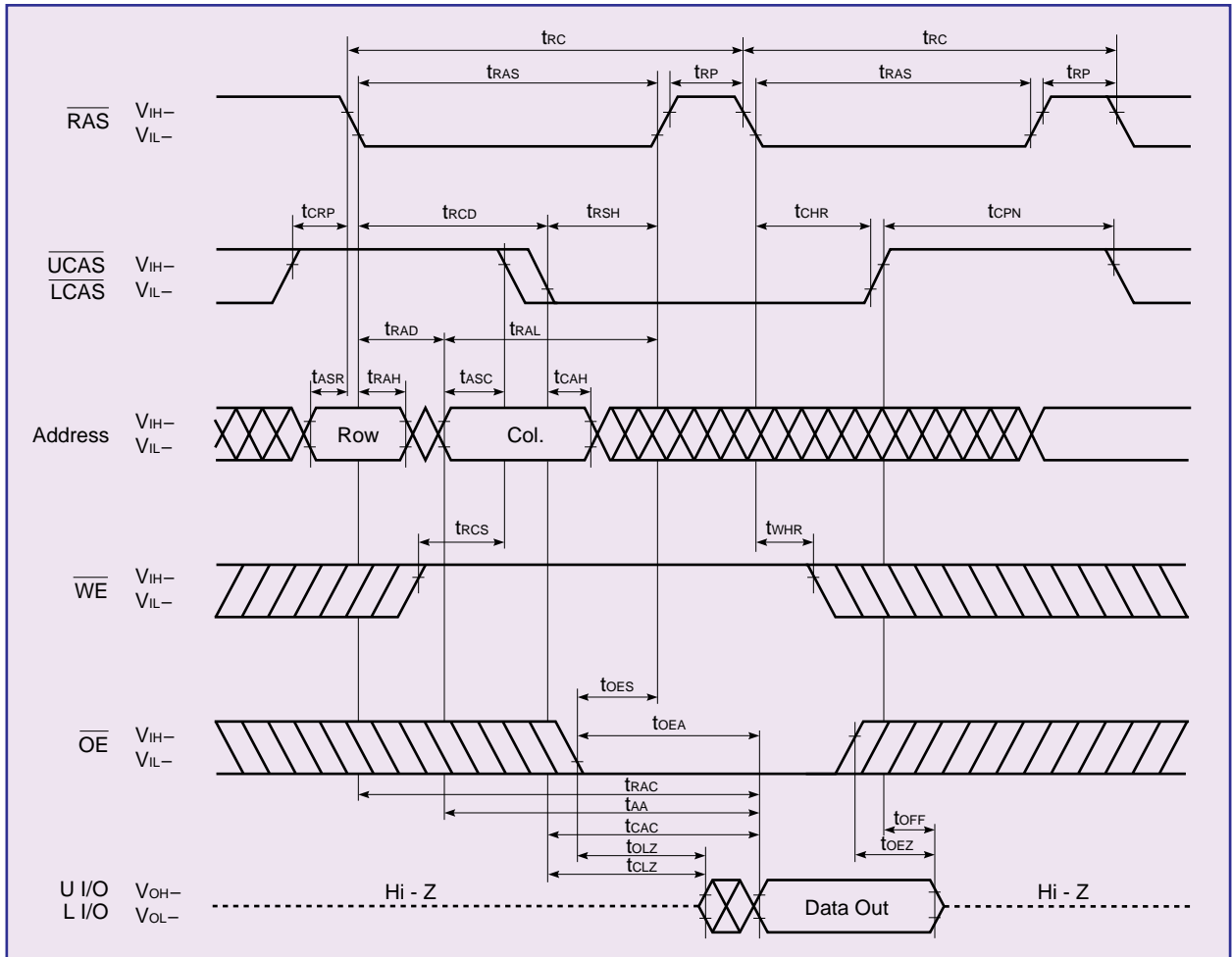

Hidden Refresh Cycle (Write)

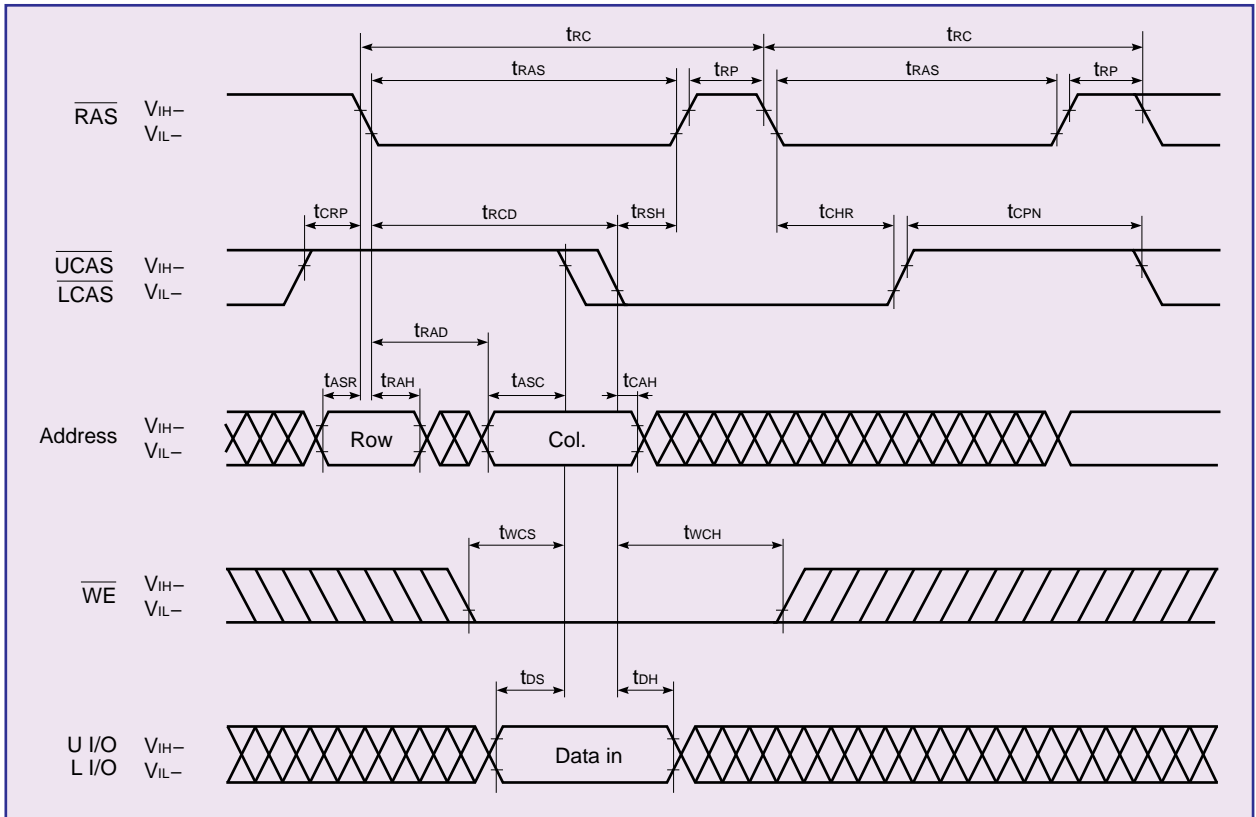

Remark \overline{OE} : Don't care

Package Drawings

44 PIN PLASTIC TSOP(II) (400 mil)

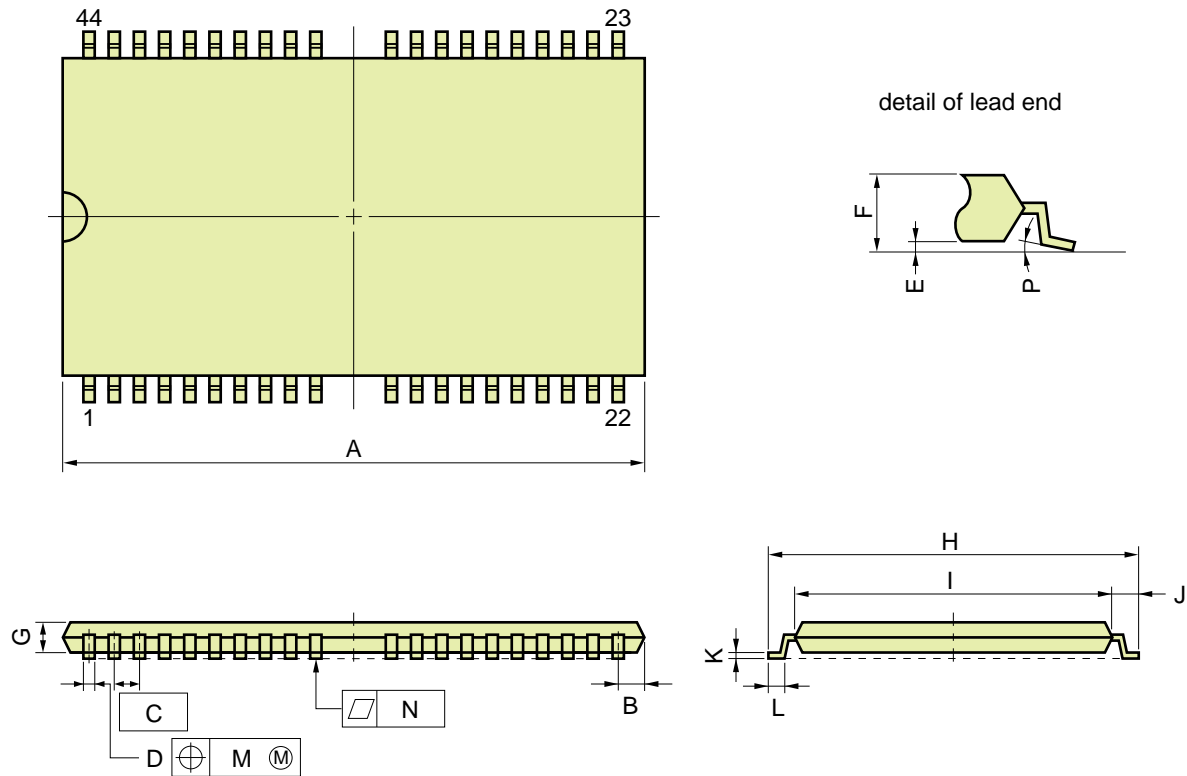

NOTE

Each lead centerline is located within 0.13 mm (0.005 inch) of its true position (T.P.) at maximum material condition.

ITEM	MILLIMETERS	INCHES
A	18.63 MAX.	0.734 MAX.
B	0.93 MAX.	0.037 MAX.
C	0.8 (T.P.)	0.031 (T.P.)
D	0.32 ^{+0.08} _{-0.07}	0.013±0.003
E	0.1±0.05	0.004±0.002
F	1.2 MAX.	0.048 MAX.
G	0.97	0.038
H	11.76±0.2	0.463±0.008
I	10.16±0.1	0.400±0.004
J	0.8±0.2	0.031 ^{+0.009} _{-0.008}
K	0.145 ^{+0.025} _{-0.015}	0.006±0.001
L	0.5±0.1	0.020 ^{+0.004} _{-0.005}
M	0.13	0.005
N	0.10	0.004
P	3° ^{+7°} _{-3°}	3° ^{+7°} _{-3°}

S44G5-80-7JF4

40 PIN PLASTIC SOJ (400 mil)

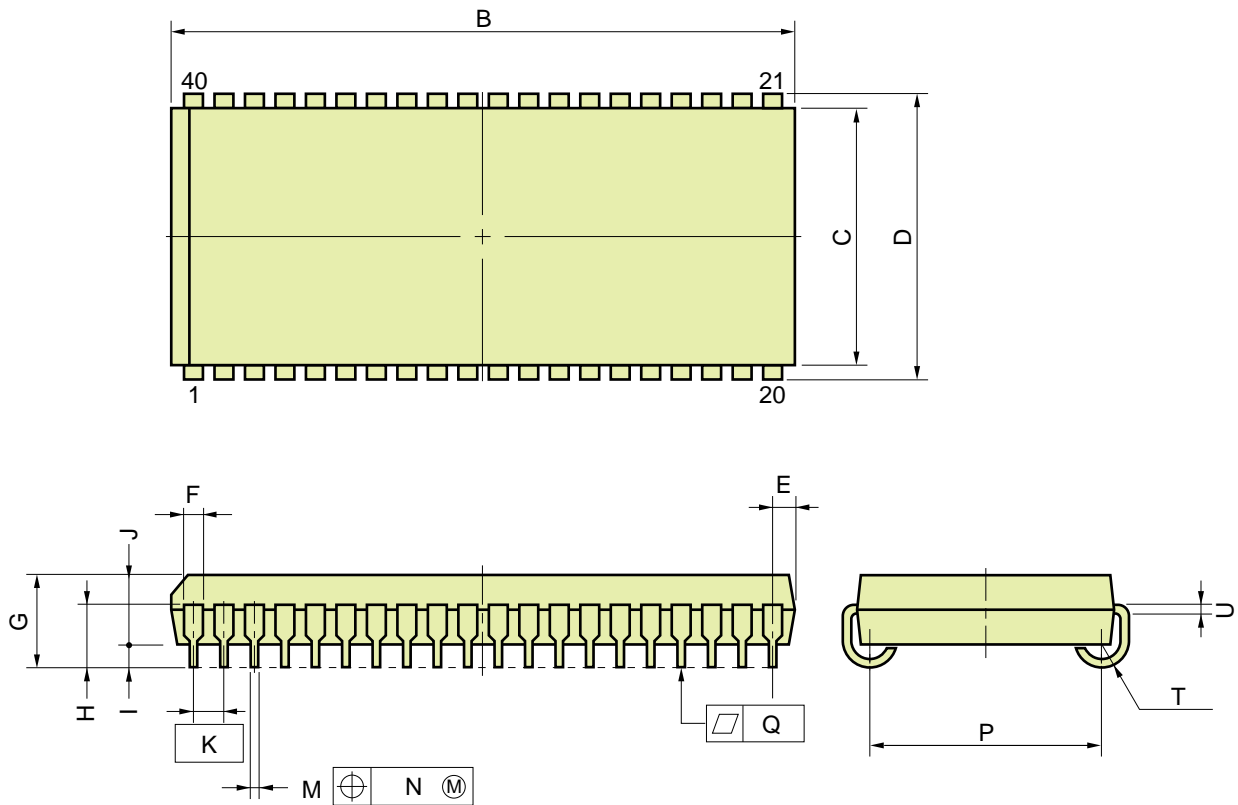

NOTE

Each lead centerline is located within 0.12 mm (0.005 inch) of its true position (T.P.) at maximum material condition.

ITEM	MILLIMETERS	INCHES
B	26.29 ^{+0.2} _{-0.35}	1.035 ^{+0.008} _{-0.014}
C	10.16	0.400
D	11.18±0.2	0.440±0.008
E	1.08±0.15	0.043 ^{+0.006} _{-0.007}
F	0.7	0.028
G	3.5±0.2	0.138±0.008
H	2.4±0.2	0.094 ^{+0.009} _{-0.008}
I	0.8 MIN.	0.031 MIN.
J	2.6	0.102
K	1.27(T.P.)	0.050(T.P.)
M	0.40±0.10	0.016 ^{+0.004} _{-0.005}
N	0.12	0.005
P	9.40±0.20	0.370±0.008
Q	0.15	0.006
T	R0.85	R0.033
U	0.20 ^{+0.10} _{-0.05}	0.008 ^{+0.004} _{-0.002}

P40LE-400A-2

Recommended Soldering Conditions

The following conditions (see tables below and next page) must be met when soldering μPD42S4260, 424260.

For more details, refer to our document “SEMICONDUCTOR DEVICE MOUNTING TECHNOLOGY MANUAL” (IEI-1207).

Please consult with our sales offices in case other soldering process is used, or in case the soldering is done under different conditions.

Types of Surface Mount Device

μPD42S4260G5, 424260G5: 44-pin plastic TSOP (II) (400 mil)

Soldering process	Soldering conditions	Symbol
Infrared ray reflow	Peak temperature of package surface: 235 °C or lower, Reflow time: 30 seconds or less (210 °C or higher), Number of reflow processes: MAX. 2 Exposure limit: 7 days ^{Note} (10 hours pre-baking is required at 125 °C afterwards) Cautions <ol style="list-style-type: none"> 1. After the first reflow process, cool the package down to room temperature, then start the second reflow process. 2. After the first reflow process, do not use water to remove residual flux (water can be used in the second process). 	IR35-107-2
VPS	Peak temperature of package: 215 °C or lower, Reflow time: 40 seconds or less (200 °C or higher), Number of reflow processes: MAX. 2 Exposure limit: 7 days ^{Note} (10 hours pre-baking is required at 125 °C afterwards) Cautions <ol style="list-style-type: none"> 1. After the first reflow process, cool the package down to room temperature, then start the second reflow process. 2. After the first reflow process, do not use water to remove residual flux (water can be used in the second process). 	VP15-107-2
Partial heating method	Terminal temperature: 300 °C or lower, Time: 3 seconds or less (Per side of the package).	—

Note Exposure limit before soldering after dry-pack package is opened.
 Storage conditions: 25 °C and relative humidity at 65 % or less.

Caution Do not apply more than one soldering method at any one time, except for “Partial heating method”.

μPD42S4260LE, 424260LE: 40-pin plastic SOJ (400 mil)

Soldering process	Soldering conditions	Symbol
Infrared ray reflow	<p>Peak temperature of package surface: 235 °C or lower, Reflow time: 30 seconds or less (210 °C or higher), Number of reflow processes: MAX. 2 Exposure limit: 7 days^{Note} (20 hours pre-baking is required at 125 °C afterwards)</p> <p>Cautions</p> <ol style="list-style-type: none"> 1. After the first reflow process, cool the package down to room temperature, then start the second reflow process. 2. After the first reflow process, do not use water to remove residual flux (water can be used in the second process). 	IR35-207-2
VPS	<p>Peak temperature of package: 215 °C or lower, Reflow time: 40 seconds or less (200 °C or higher), Number of reflow processes: MAX. 2 Exposure limit: 7 days^{Note} (20 hours pre-baking is required at 125 °C afterwards)</p> <p>Cautions</p> <ol style="list-style-type: none"> 1. After the first reflow process, cool the package down to room temperature, then start the second reflow process. 2. After the first reflow process, do not use water to remove residual flux (water can be used in the second process). 	VP15-207-2
Partial heating method	<p>Terminal temperature: 300 °C or lower, Time: 3 seconds or less (Per side of the package).</p>	—

Note Exposure limit before soldering after dry-pack package is opened.
 Storage conditions: 25 °C and relative humidity at 65 % or less.

Caution Do not apply more than one soldering method at any one time, except for “Partial heating method”.