

Operating Manual

Control and Power Unit

DCE 1500

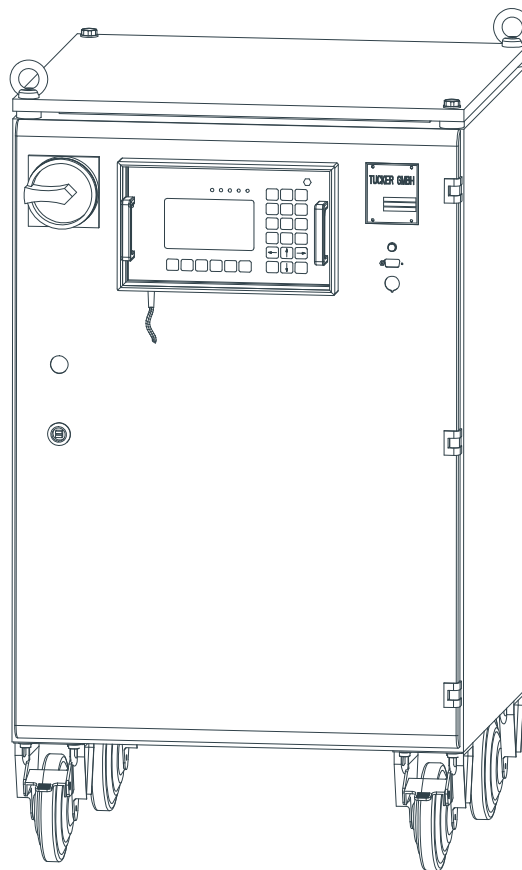

Please read the operating manual before any operation!



© Emhart Teknologies TUCKER GmbH

Max-Eyth-Straße 1

D-35394 Gießen

Tel.: +49 (0) 641 405 0

Fax.: +49 (0) 641 405-383

E-Mail: info@tucker.de

Internet: www.tucker.de

Table of Contents

1	General Information.....	5
1.1	Information Regarding the Operating Manual	5
1.2	Limitation of Liability	5
1.3	Symbol Legend	6
1.4	Copyright Protection.....	7
1.5	Replacement Parts.....	7
1.6	Guarantee Instructions.....	8
1.7	After Sales Service.....	8
2	Safety	9
2.1	Responsibility of the Operating Company	9
2.2	Personnel Requisition	10
2.2.1	Qualification.....	10
2.2.2	Trespassers.....	11
2.2.3	Instruction.....	11
2.3	Intended Use.....	12
2.4	Personal Protective Equipment.....	13
2.5	Special Risks.....	14
2.6	Safety Devices	15
2.6.1	Operator Protection	15
2.6.2	Interruption of Operation	15
2.7	Securing Against Resetting.....	16
3	Technical Specifications.....	17
3.1	General Specifications	17
3.2	Connected Loads	17
3.3	Fuse Elements	19
3.4	Dimensioned Drawing	21
3.5	Type Plate	22
4	General Description.....	23
5	Assembly and Connections.....	24
5.1	Layout DCE 1500.....	24
5.1.1	Main Switch	25
5.1.2	Key Switch Maintenance Operation	25
5.1.3	LED Fuses.....	25
5.1.4	Connection PC / Laptop RS 232	25
5.1.5	Connection Control terminal.....	26
5.2	Layout Inside of the Device.....	27
5.2.1	Connection Power Supply	28
5.2.2	Connection Safety Circuit X2	28

Table of Contents

- 5.2.3 Connection of Measurement Lines A1-X8 SF1 - A1-X12 SF5..... 28
- 5.2.4 Connection Weld Cables A1-X2 SF1 - A1-X6 SF5 29
- 5.2.5 Connection Control Cables X3 SF1 - X7 SF5..... 29
- 5.2.6 Connection Ground Cable A1-X1 30
- 5.2.7 Connection Ground-Measurement line A1-X7 30
- 5.2.8 Connection of customer interface X8..... 31
- 5.3 Layout 1: DCE in standard operation..... 32
- 5.4 Layout 2: DCE in SD 2 Operation..... 33
- 5.5 Layout 3: DCE with PKE 34
- 6 Display- and Control Elements..... 35
- 7 Conversion from Keypad to Touchpad..... 36
- 8 Notes Regarding Stud Welding..... 38
- 9 DCE 1500 Start-Up 39
- 10 Transport, Packaging and Storing 41
 - 10.1 Security Advice for the Transport 41
 - 10.2 Transport Check 42
 - 10.3 Transport 42
 - 10.4 Terms and Conditions for Overseas Transport..... 44
 - 10.5 Packaging 45
 - 10.6 Storing 45
- 11 Maintenance and Cleaning 46
 - 11.1 Safety..... 46
 - 11.2 Maintenance and Cleaning Schedule 46
 - 11.3 Cleaning of the Filter Insert..... 47
- 12 Disposal 48

Appendix: EC- Declaration of Conformity

1 General Information

1.1 Information Regarding the Operating Manual

This operating manual contains important information regarding the handling of this device. The compliance with all security advisories and operation instructions is a precondition for a safe operation.

Furthermore the local accident prevention regulations and the general safety regulations effective for the application area of the device have to be observed.

Please read the operating manual carefully before any operation! It is a part of the product and has to be stored in an accessible location in the direct vicinity of the device for use by the appropriate personnel.

1.2 Limitation of Liability

All instructions and information in this operating manual have been compiled in consideration of the valid standards and regulations, the state of the art as well as our experience of many years.

The manufacturer assumes no liability for damages due to:

- Non-observance of the operating manual.
- Not intended use.
- Employment of unskilled personnel.
- Arbitrary rebuilding.
- Technical modifications.
- Use of non-licensed replacement parts.

On special design, on demands of additional order options or due to latest technical modifications the actual shipment may differ from the explanations and expositions described here.

Effective are the obligations agreed in the supply contract, the general terms and conditions as well as the delivery conditions of the supplier and the legal regulations valid to the time of conclusion of the contract.

Technical modifications within the improvement of the usage properties and the further development are reserved.

General Information**1.3 Symbol Legend****Warning notices**

The warning notices in this operation manual are indicated by symbols. The notes commence with a signal word which expresses the extent of the danger.

Observe the notes and act with caution to avoid accidents and damage to persons and property.

**DANGER!**

... points to a directly dangerous situation which can lead to death or severe injuries if it is not avoided.

**WARNING!**

... points to a possibly dangerous situation which can lead to death or severe injuries if it is not avoided.

**CAUTION!**

... points to a possibly dangerous situation which can lead to slight injuries if it is not avoided.

**CAUTION!**

... points to a possibly dangerous situation which can lead to damage of property if it is not avoided.

Tips and recommendations**NOTE!**

... highlights useful tips and recommendations as well as information for an efficient and failure-free operation.

Special security advisories

In order to draw attention to special dangers, the following symbols are used in connection with security advisories:

**DANGER!****Danger to life by electric current!**

... indicates perilous situations by electric current. Disregarding of the security advisories can lead to severe injuries or death.

The operations which need to be carried out may only be executed by electronic technicians.

1.4 Copyright Protection

This instruction is protected by copyright and only intended for internal purposes.

The provision of the instruction to a third party, duplications in all kinds and forms - also in extracts - as well as the utilisation and/or communication of the content are, aside from internal purposes, not permitted without a written authorization of the manufacturer.

Non-compliances obligate to damages. Further claims remain reserved.

1.5 Replacement Parts

**WARNING!****Safety risk due to false replacement parts!**

False or defective replacement parts can affect the safety as well as lead to damages, malfunctions or total breakdown.

Therefore:

- Use original TUCKER replacement parts.

Purchase replacement parts via licensed dealer or directly at manufacturer.
Address see page 2.

General Information**1.6 Guarantee Instructions**

For material and manufacturing faults, the guarantee period for this control and power unit amounts to 1 year from delivery date on. Excluded from this is damage that is caused by accident or by incorrect handling.

The guarantee covers free-of-charge replacement of the faulty component. In this connection, liability for consequential damage is excluded.

Guarantee void in case of attempts to repair by personnel that has not been trained by the manufacturer and/or when using spare parts that TUCKER has not approved of. In the event of a defect the non-conforming appliance must be sent to the next TUCKER agent or directly to the manufacturer.

The guarantee claim lapses when attempts at repair are carried out by unauthorised or unqualified persons. In the event of a defect the non-conforming appliance must be sent to the next TUCKER agent or directly to the manufacturer. For further information concerning national representation, our customer service is at your disposal. The corresponding contact data can be found on page 2.

1.7 After Sales Service

Our service department is available for technical support.

Information about the responsible contact person is available via telephone, fax, E-Mail or anytime via the Internet, please see manufacturer address on page 2.

Furthermore, our employees are constantly interested in new information and experiences that result from the single applications and could be helpful for improving our products.

2 Safety

This paragraph gives a review about all important safety aspects for an optimal protect of the personnel as well as for the safe and failure-free operation.

Disregard of the operating instructions and security advices mentioned in this manual could lead to serious dangers.

2.1 Responsibility of the Operating Company

This unite is used industrially. Therefore the operating company of the unit is liable to the legal obligations of operational safety.

In addition to the operational safety advices in this operating manual the safety-, accident prevention- and environmentalism regulations valid for the area of application need to be observed.

Please consider particularly the following:

- The operating company has to inform himself about the valid industrial safety regulations and determine additional dangers in an assessment of hazards which occur by the special working conditions on the site of the unit. He has to implement these for the operation of the unit in the form of operating instructions.
- The operating company has to verify that the operating instructions are state of the art during the complete operating time of the unit. If necessary, the operating company is to adjust the operating instructions to the valid rules and regulations.
- The operating company has to manage and determine the responsibilities for installation, operation, maintenance and cleaning in an explicit manner.
- The operating company has to ensure that all employees dealing with the unit have read and understood this manual. Moreover, the operating company has to train the operating personnel in regular intervals and has to provide information on possible dangers.
- The operating company has to provide the personnel with the required protective equipment.

2.2 Personnel Requisition

2.2.1 Qualification

**WARNING!****Risk of injury on insufficient qualification!**

Improper handling can lead to serious damage to persons and property.

Therefore:

- All activities are to be carried out by skilled personnel only!

The following qualifications for different areas of operations are named in the operating manual:

Instructed person

- Has been informed about the tasks assigned and possible dangers of improper execution of an instruction by the operating company.

Qualified personnel

- Qualified personnel are able to carry out the assigned tasks due to their qualified training, knowledge and job experience. In addition, the personnel are able to recognize and avoid possible dangers on their own.

Electrician

- The electrician is able to carry out activities on electric units due to his qualified training, knowledge and job experience. In addition, he is able to recognize and avoid possible dangers on his own.
- The electrician has been trained for the special site he is working on and knows about the relevant rules and regulations.

Only persons who can be expected to carry out their work in a reliable manner can be accepted as personnel. Persons whose reactivity is influenced, e.g. by drugs, alcohol or medicaments, are not admitted.

- Please consider the regulations at site specific to age and profession when choosing personnel!

2.2.2 Trespassers



WARNING!

Danger for trespassers!

Trespassers who do not fulfil the requirements mentioned in this document do not know about the dangers of this working area.

Therefore:

- Keep trespassers away from the working area.
- When in doubt, approach persons and banish them from the working area.
- Interrupt your work as long as there are trespassers within the working area.

2.2.3 Instruction

The personnel have to be instructed regularly by the operating company. For a better traceability the implementation of the instruction should be recorded.

Date	Name	Kind of instruction	Instruction carried out by	Signature

2.3 Intended Use

The DCE 1500 control and power unit was designed exclusively for the intended use mentioned in this manual.

The control and power unit DCE 1500 was designed exclusively for drawn arc welding of TUCKER weld studs and nuts and only for application in premises.

Intended use also includes observing all the symbols and information in the operating manual.

Any excess of the intended use or different use of the device is considered as misuse and can lead to dangerous situations.



WARNING!

Risk by not intended use!

Every not intended use and/or different use can lead to dangerous situations.

Especially refrain the following use of the device:

- Use with feeding units and dividers of other manufacturers.
- Use with weld heads and weld guns of other manufacturers.
- Use in explosive areas.
- Use in damp locations.

Claims of any kind because of damages due to not intended use are excluded.

An electro-magnetically interference-free operation of the DCE 1500 can be guaranteed by complying with the specifications in chapter 6 "Connection and installation"!

2.4 Personal Protective Equipment

At work wearing personal protective equipment is essential to minimize the risks for the health.

- During working time always wear the required protective equipment for the respective work.
- Observe the signs regarding the personal protective equipment which exist in the working area.



Protective glasses

For the protection of the eyes from foreign bodies.



Protective clothing

is close-fitting work wear with low tear strength, with tight-fitting sleeves and without flared parts. It is principally used to protect against capture by moving machinery parts. Do not wear rings, necklaces and other jewellery.



Safety boots

For the protection from heavy, falling parts and from slipping on slippery surfaces.

2.5 Special Risks

The residual risks which arise from the hazard analysis are described in the following chapter.

Please consider the below mentioned security advices and warnings in the following chapters of this manual to reduce health hazards and to avoid dangerous situations.

Electric current



DANGER!

Danger of life by electric current!

Contact with components under current is perilous. Damage of the electrical isolation or of several components can be perilous.

Therefore:

- Before start of work test all connection lines of the control and power unit for damage.
- On damages of the electrical isolation cut-off immediately the power supply and induce repairing.
- Work on the electric installation may only be executed by electricians/electronic technicians.
- During all work on the electric installation you have to switch it dead and test if it is zero-potential.
- Do not connect or disconnect the live plug connector.
- Keep away moisture from current conducting parts. This way leads to short circuit.
- On adjustments and repairing switch off the main switch of the device and disconnect the device from the power system.
- After switch off of the control and power unit (main switch in position "0") open the door of the device first after 2 minutes with the special key.



Under no circumstances are persons using a cardiac pacemaker to operate or remain in the vicinity of stud welding machines.

2.6 Safety Devices

The control and Power unit DCE 1500 is designed for the application within an installation. It can be integrated into the customer internal safety control via the connector "Safety circuit".

The connector plug for the safety circuit is included in delivery of the DCE and it serves to route the 24V power to the respective customer interface and to integrate the weld unit into a customer safety circuit control (Operator protection, stop-operation).

Depending on construction of the DCE, manual or automatic operation, the power socket "Safety circuit" has to be bypassed accordingly by qualified personnel of the operator or by the Tucker service technician.

Please also see operating manual "Safety module E485A".

2.6.1 Operator Protection

The DCE could be integrated into the customer specific emergency stop circuit, single- or dual channel (category 2 or 4), via connection "Safety circuit" in order to be able to switch off the SMPS including peripherals in an emergency situation.

If an emergency stop signal is issued, the master contactor in the DCE disconnect the power section and all connected devices from the power supply. Welding processes which already started will be stopped.

The control electronics and the control panel will be furthermore supplied with voltage.

After the emergency stop was lift, the operating state delays, after re-start of the DCE about a holding time of approx. 40 seconds.

2.6.2 Interruption of Operation

Irrespective of the integration of the control & power unit into the customer-specific emergency-stop circuit, the user can also initiate an interruption of operation of the DCE, single- or dual channel (category 2 or 4), if the Han 10B connector plug "Safety circuit" is configured accordingly. As is the case for the operator protection, feeding and welding of studs will be terminated after the last welding process has been executed

After cancelling the stop-operation, normal operation will be delayed for ca. 10 seconds.

2.7 Securing Against Resetting



WARNING!

Mortal danger because of unauthorized resetting!

When working in the danger zone, there is the risk that the power supply is reset without authority. This means the persons within the danger zone are in a life-threatening situation.

Therefore:

- Please always consider the activities for securing against resetting shown below.

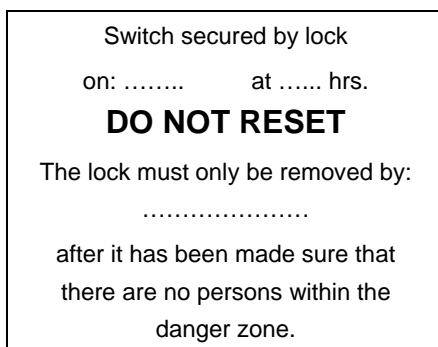

Figure 1

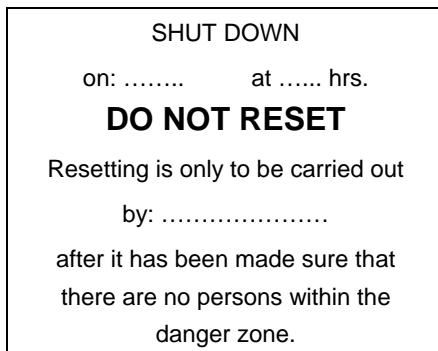

Figure 2

Securing against resetting:

1. Cut off power supply.
2. If possible, secure the switch by means of a lock. Please adjust a sign in accordance with figure 1. The sign should be attached to the switch so that it can be seen.
3. The employee named on the sign should keep the key.
4. In case it is not possible to secure the switch by means of a lock, please set up a sign according to figure 2.
5. After all work is done, please make sure that there are no persons within the danger zone anymore.
6. Installed and operating.
7. Only now you may remove the sign.

3 Technical Specifications

3.1 General Specifications

	Specification	Value	Unit
	Weight	approx. 90	kg
	Width	approx. 570	mm
	Height	approx. 1000	mm
	Depth	approx. 685	mm
	System of protection: Protected against solid objects until 12 mm.	IP 23 according IEC529	Protected against water drops
	Operating temperature	15 - 40	°C
	Stocking temperature	-25 - 55	°C
	Relative humidity of air, not condensing	5 - 95	%
	Operation Mode	Automatic	
	Working Position	vertical	
	Display	40x16	Matrix-module
	Dot size	0,4x0,4	mm
	Character height	2,65x3,55	mm
Electromagnetic compatibility	The control and power unit DCE 1500 has been tested following the DIN EN 60 974-10.		

3.2 Connected Loads

Electrical	Specification	Value	Unit
	Power supply $\pm 10\%$	400/440/500	V AC
	Supply frequency $\pm 5\%$	50/60	Hz
	Max. effective idle voltage	110,0 137,5	V at 400V V at 500V
	Max. duration of power supply Interruptions	at I=1500A	5 ms
	DC voltage	55	V at 400V
	Effective current-out	130	A

Technical Specifications

Electrical	Specification	Value	Unit
	Weld current range	ΔI : 20-1500	A
	Weld time range	Δt : 36-160	ms
	Output peak capacity	PA: 80	KVA at 400V AC
	Number of welds	60 min ⁻¹ at	I= 750A, t= 30 ms
		30 min ⁻¹ at	I=1500A, t= 30 ms
		at 30°C environmental temperature	
	Control system	PI-Controller	
	Control range	ΔI : 10	A

Weld parameter

Adjustment range	Specification	Value	Unit
	Pilot current	20	A
	Pilot current time	30	ms
	Weld current	100-1500	A
	Weld time	6-350	ms
Clearance	Weld current	ΔI_s : 10	A
	Weld time	Δt_s : 1	ms

Stud feeding times

Interval	Specification	Value	Unit
	Loading time	0-1000	ms
	Feeding time	300-2500	ms
Clearance	Loading time	Δt_L : 50	ms
	Feeding time	Δt_z : 50	ms

3.3 Fuse Elements



DANGER!

Opening of the appliance door as well as the inspection of the internal fuse elements is reserved for qualified electricians.

In order to avoid an electrical accident caused by contact-hazardous components the below listed sequence is peremptory when exchanging defective fuse elements.

1. Switch the DCE off at main switch!
2. Switch off the power supply externally!
3. Open the door with the special key.



Fuses in the control cabinet	Fuse	Nominal voltage (V)	Nominal current (A)	Tripping characteristic
NH	F1 - F3	500	32	time-lag
DIAZED	F4 - F6	500	2	time-lag
DIAZED	F7 - F8	500	10	time-lag



NOTE!

Defective fuse elements are always to be replaced by the same design of fuses with identical nominal values.

Technical Specifications

The miniature fuses F1-F5 described below protect the DCE from any risk of transient current damage. The fuses are located on the printed circuit board on the control cabinet door below.

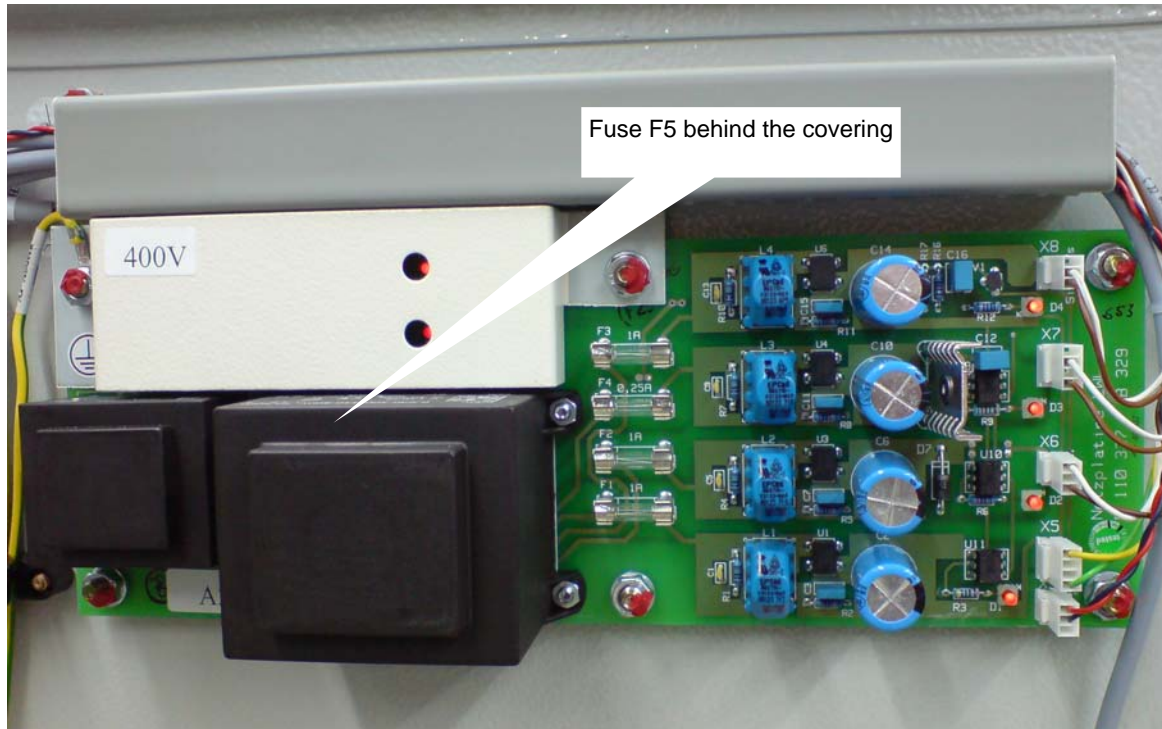

The voltage of the protected circuits is 24V.

PCB auxiliary board	Fuse	Nominal voltage (V)	Nominal current (A)	Tripping characteristic
5x20 mm	F1	250	1	semi-time-lag
5x20 mm	F2	250	1	semi-time-lag
5x20 mm	F3	250	1	time-lag
5x20 mm	F4	250	0,25	semi-time-lag
5x20 mm	F5	250	1	semi-time-lag



NOTE!

Defective fuses will be displayed by a LED being unlit. They are basically to be replaced by identical fuses with identical nominal values.

3.4 Dimensioned Drawing

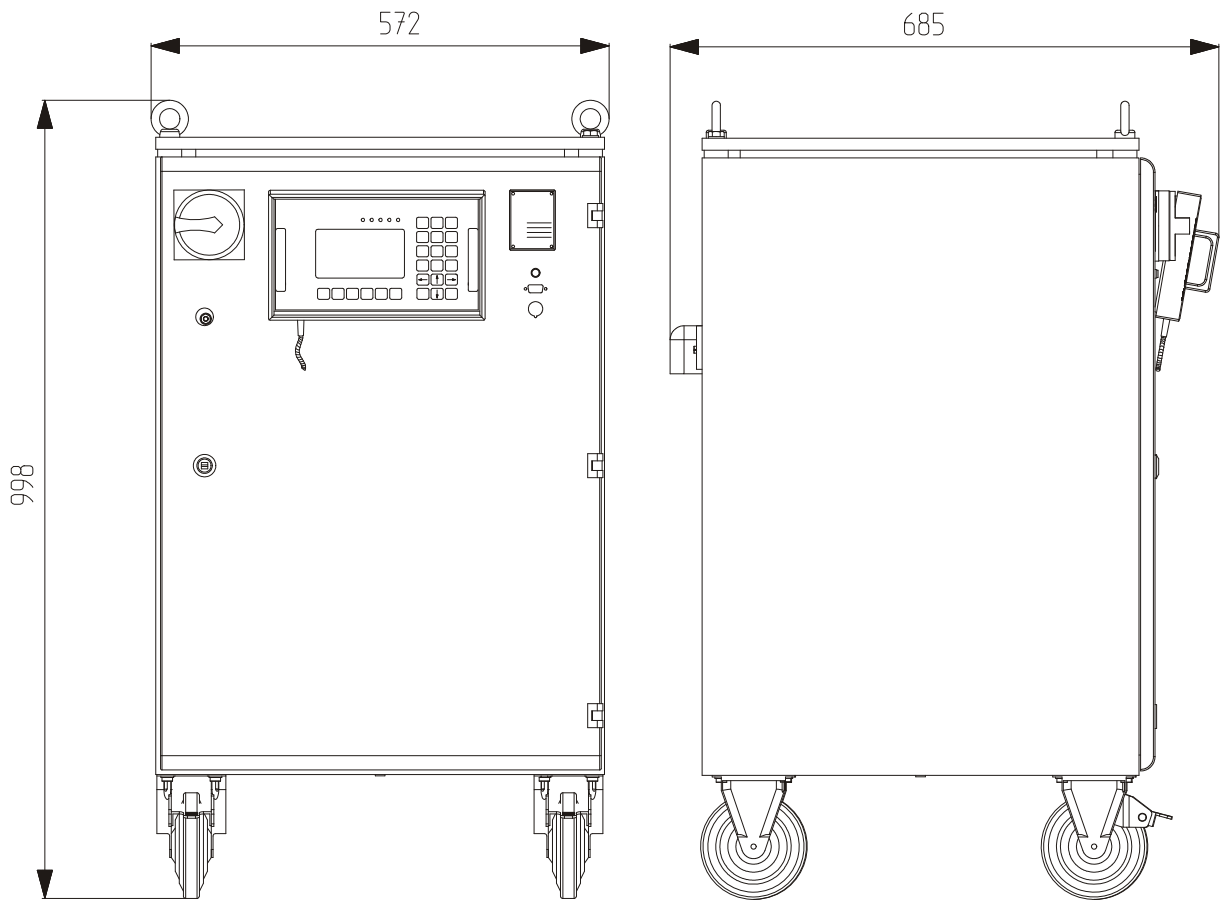

Technical Specifications**3.5 Type Plate**

Type plate

The type plate is located above to the right on the door of the control cabinet and contains the following information:

- Manufacturer
- Part number
- Power supply with frequency
- Type description
- Serial number

4 General Description

The DCE 1500 is an efficient and modern control and power unit, which was developed by TUCKER for drawn arc stud welding processes. It can be used as a single or multiple stud weld unit.

Depending on the DCE 1500 model up to five "SFLM" or "ETF" type stud feeders can be connected in standard operation, each of which supply a weld head or a weld gun with studs.

There is also the possibility of operating with a 2-way stud divider SD 2 or a multiple stud divider SD X as well as using a colour marking unit for marking defectively welded studs.

The core of the DCE weld unit is a digitally controlled weld current source which due to its high operating frequency can intervene into the weld current, even in the case of extremely short weld currents. In addition, the electric arc voltage can be influenced in a control technique fashion together with the digitally-controlled linear motor drive of the Tucker welding tools.

Furthermore the DCE 1500 is able to compensate for short-term power supply interruptions as well as for changes in weld resistance and arc voltage fluctuations within one millisecond.

The integration of 16 bit microprocessors as well as digital signal processors and the utilisation of plastic optical fibres guarantee quick access to the individual modules and ensure a high degree of data transmission reliability. The entire software can be directly downloaded from a PC/laptop to DCE by means of a flash memory.

The data saved in the DCE can be transmitted to a central PC/Laptop via a standard interface. Networking capability of the control & power unit is provided via an Ethernet interface.

Communication to the DCE control & power unit with an external controller is accomplished via a customer interface. There are two options available, one parallel or one serial interface version.

The DCE 1500 is equipped with a Category 2 safety device. A Category 4 device is optionally available.

5 Assembly and Connections

5.1 Layout DCE 1500

The operating elements of the DCE are located on the front door and the control panel which can be affixed on the appliance door.

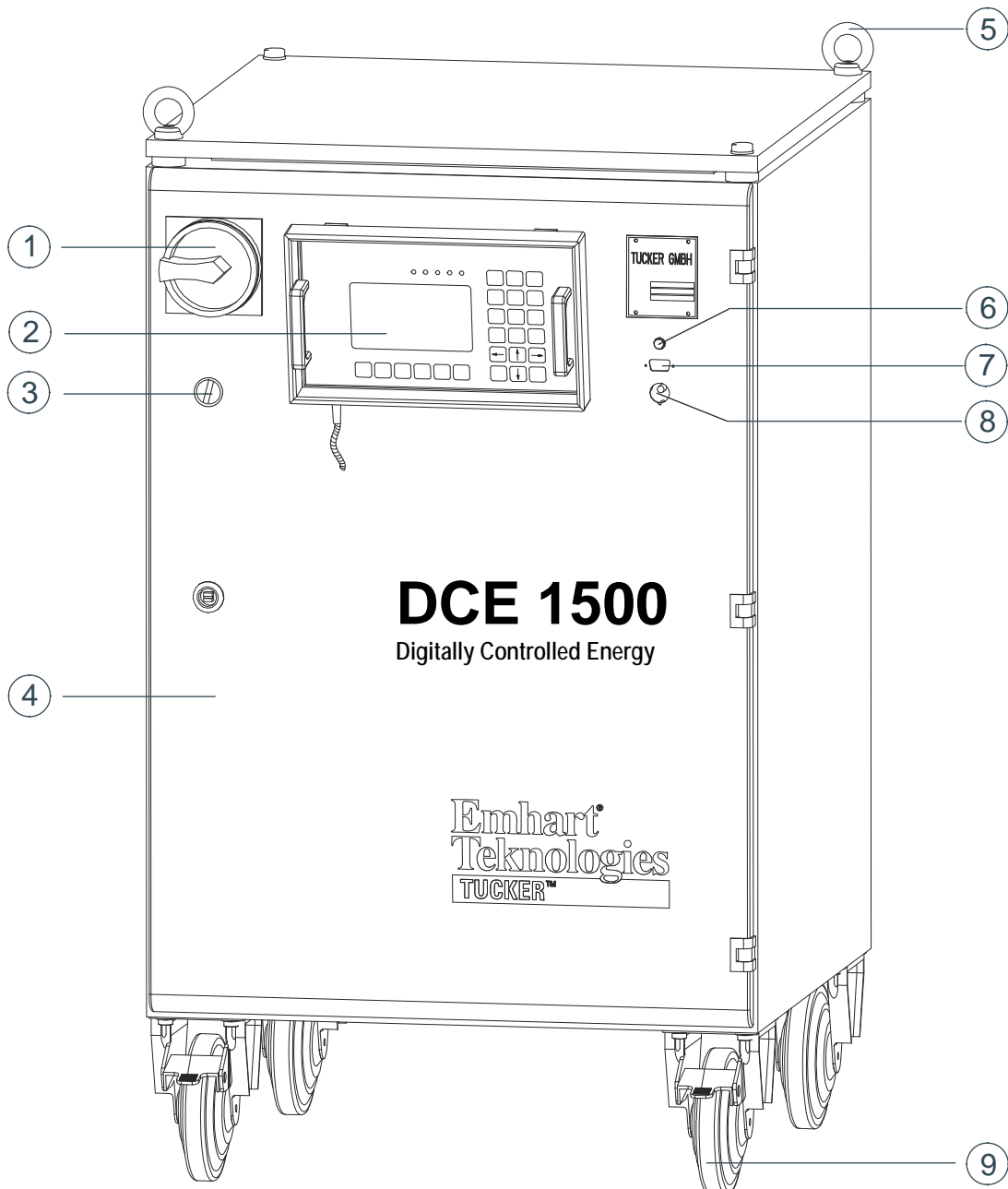

- | | | | | | |
|---|---------------|---|-------------|---|---------------------|
| 1 | Main switch | 4 | Door | 7 | PC Interface RS232 |
| 2 | Control panel | 5 | Crane eye | 8 | Connection Terminal |
| 3 | Key switch | 6 | LED "Fuses" | 9 | Transport roller |

5.1.1 Main Switch



The control and power unit can be switch ON/OFF by means with the main switch.

The main switch is located above to the left on the door of the control cabinet in standard version.

5.1.2 Key Switch Maintenance Operation



Maintenance operation is released by switching the key switch "Maintenance operation" and initiated by closing the input circuits E10 (⇒ separate operating manual "Safety module E485A")

5.1.3 LED Fuses

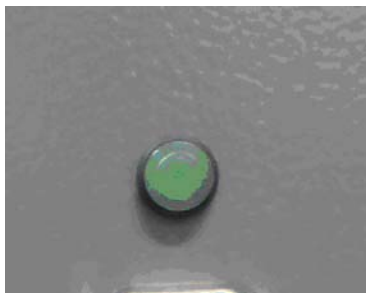

This LED will remain lit if the phase conductors L1, L2 and L3 have been correctly connected to the control and power unit and if the fuses on the auxiliary board as well as all main fuses are available.

5.1.4 Connection PC / Laptop RS 232



The serial interface RS 232 serves to input and output the weld program data having been saved in the DCE control and power unit to a personal computer or laptop. Furthermore, new versions of the DCE and ETF operating software can be loaded from a laptop or PC into the DCE flash memory.

For requests regarding PC and software please see manufacturer address page 2.

5.1.5 Connection Control terminal



On this connection the control panel (Keypad) can be connected to the control and power unit.

Thus the programming and error correction is possible.
(⇒ chapter Display- and control elements).

5.2 Layout Inside of the Device

Apart from the interface the DCE is equipped with the connection possibilities listed below which may be configured differently depending on the selected unit configuration.

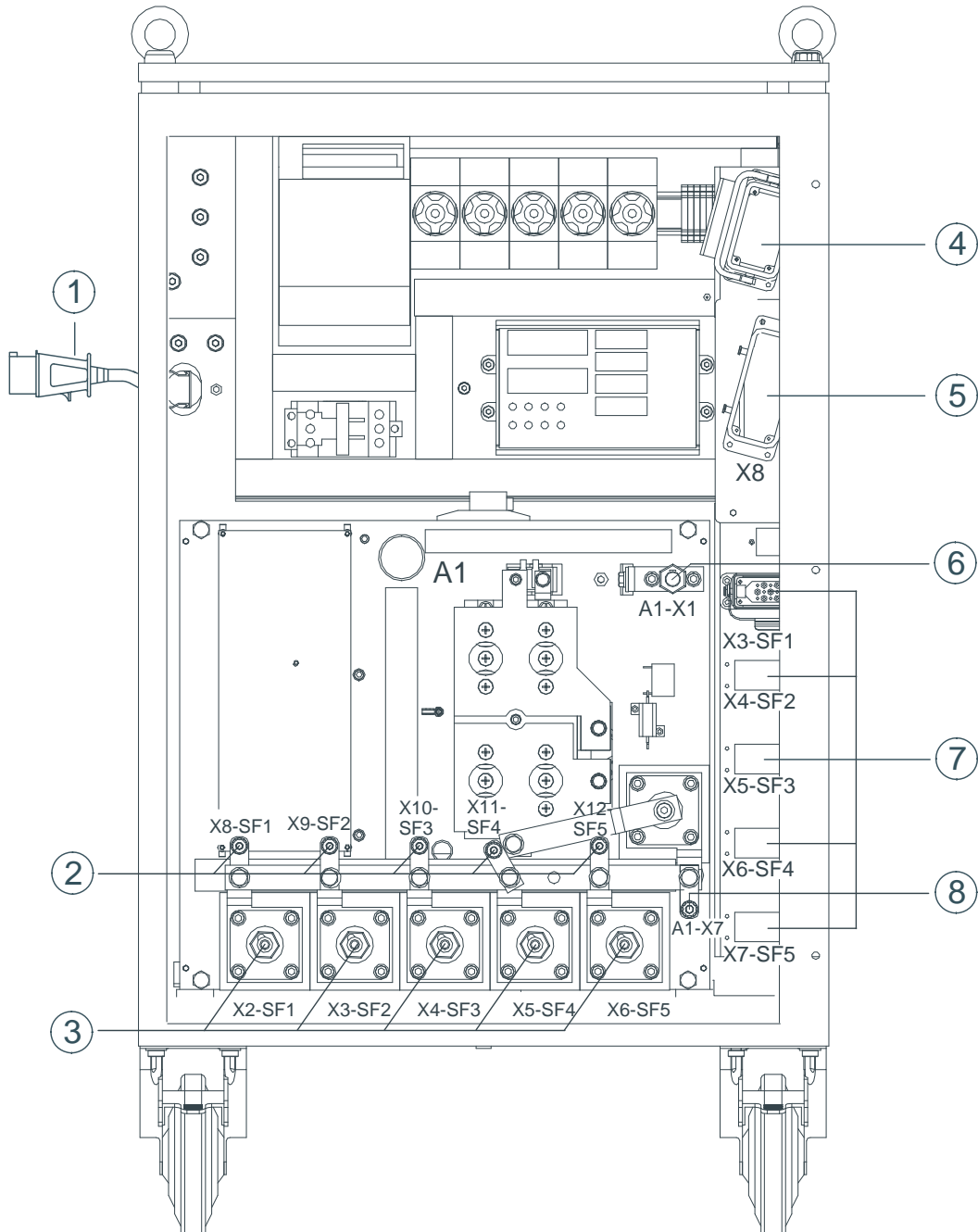

- | | | |
|---------------------------|-----------------------------|---------------------------------|
| 1 Power supply | 4 Safety circuit | 7 Control cables |
| 2 Measuring cables | 5 Customer Interface | 8 Ground measuring cable |
| 3 Weld cables | 6 Ground cable | |

5.2.1 Connection Power Supply



Power supply

Power (A.C. and D.C.) must always be supplied by the user of the weld unit.

Depending on the voltage supply available the DCE 1500 may be connected to the following AC. Voltage via CEE 32A plug:

- AC 400V; 50/60 Hz
- AC 440V; 50/60 Hz
- AC 500V; 50/60 Hz

5.2.2 Connection Safety Circuit X2



Safety circuit

The connector plug for the safety circuit is included in delivery of the DCE and it serves to route the 24V power to the respective customer interface and to integrate the control and power unit into a customer safety circuit control (Operator protection, stop-operation).

5.2.3 Connection of Measurement Lines A1-X8 SF1 - A1-X12 SF5

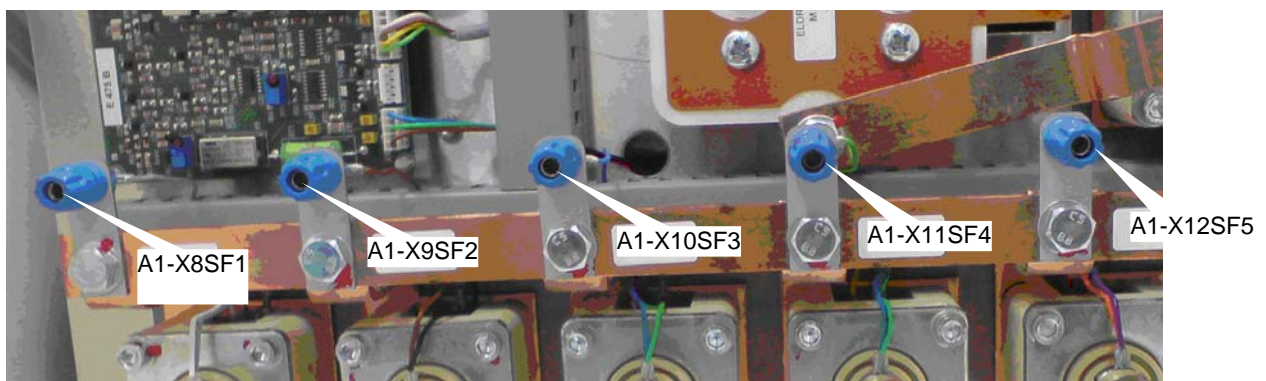

The measurement lines are to be connected to the blue pole sockets "A1-X8 SF1" up to "A1-X12 SF5" of the DCE 1500 and to the corresponding stud feeders.

The potential of the arc voltage measured at the weld tool will be transmitted to the DCE 1500 via the measurement lines and the stud feeder. Please note that the measurement

lines may not be subject to tension since the pole sockets cannot be locked.

5.2.4 Connection Weld Cables A1-X2 SF1 - A1-X6 SF5

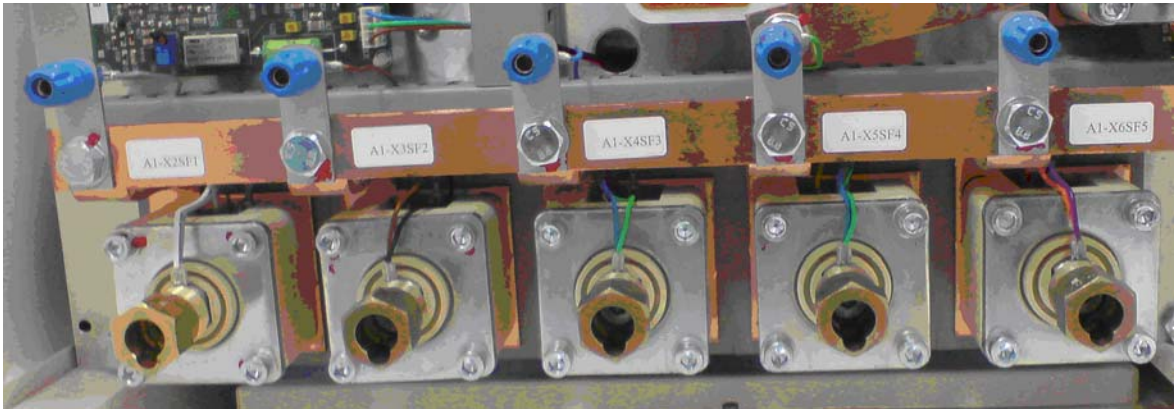

The weld cables are to be connected to the sockets "A1-X2 SF1" up to "A1-X6 SF5" of the DCE control and power unit and to the feeders and then to be locked by a clockwise rotation.



NOTE!

If possible, the weld cables should be installed separately from control cables and power supply cables to prevent electromagnetic interference.

5.2.5 Connection Control Cables X3 SF1 - X7 SF5



Control cables

The control cable contains the copper lines for the power supply of the respective feeder as well as the light-transmitting fibre for signal transmission.

The DCE connector sockets for the control cable are to be configured according to configuration of the unit.

The following operation modes can be distinguished:

Assembly and Connections

1. Standard Operation with stud feeder and weld tool (LM/SKK/PK/PLM)

Up to five "SF, SFLM or ETF" type stud feeders each of which supply one weld head (LM/SKK) or one weld gun (PLM/PK) with studs can be connected to the connections marked X3 SF1 - X7 SF5 (see connection diagram 1). The ETF feeder can be equally operated in the same manner as the only conventional and LM-driven welding tool.

2. Stud Divider Operation with a 2-way stud divider SD2

The stud feeder for controlling the stud divider is to be connected to the socket X3 SF1 (see layout 2). The stud feeder for feeding the second stud is to be connected to the socket X4 SF2 located below.

3. Manual Weld Gun Operation

For the operation of up to five weld guns with manual stud feed via the control and power unit DCE 1500, a PKE connection box is required.

The control cable of the PKE is always to be connected to the DCE socket "X3 SF1" (see layout 3).

The remaining control cable connections are available for standard applications.

5.2.6 Connection Ground Cable A1-X1

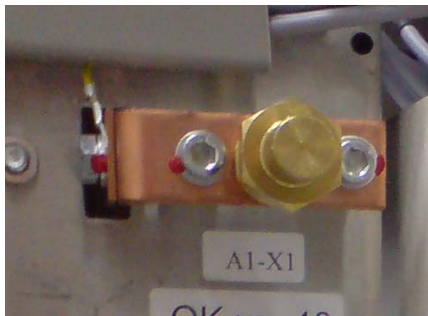

Ground cable

By connecting the ground cable to the coupler plug (X1) electrical connection between the DCE and the work piece has been accomplished. The ground cable will be locked by a clockwise rotation.

5.2.7 Connection Ground-Measurement line A1-X7

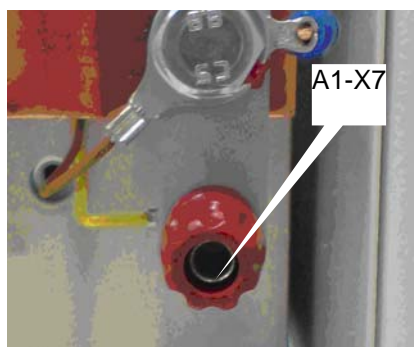

Ground-measurement line

Connecting the ground-measurement line to the work piece and to the red pole socket "A1 - X7" of the DCE is the condition for automated controlling and monitoring of the weld sequence which allows parameter optimisation. Please note that the ground-measurement line may not be subject to tension since the pole socket cannot be locked.

5.2.8 Connection of customer interface X8

During automated welding operation the digital signal transmission to the external controller will be achieved by the customer interface.

There are three different versions of customer interfaces available:

- Parallel interface (24 inputs and 24 outputs; connection X8).
- Serial interface to be connected to Pro-Bus-DP.
- Serial interface to be connected to Interbus-S.



Parallel interface

Control signals, feeding and weld instructions may be exchanged via the interface between DCE 1500 and external controller in order to transmit the corresponding orders to the stud feeder (ETF) or the weld head (SKK/LM).

In manual welding operation the interface is unconsidered for the external customer control as all control functions are executed by the DCE and the weld instructions are given by the operator self.



NOTE!

Further interfaces on request.

Information about the responsible contact person is anytime available via telephone, fax, E-Mail or via Internet, please see manufacturer address page 2.

The technical description of the specific customer interface can be taken from the operating manuals “customer interfaces”.



NOTE!

In order to ensure signal exchange between DCE 1500 and customer control the 24V power supply of the interface must always be provided by the user of the unit.

Remark: The user-specific configuration of the DCE connections can be taken from the following layouts 1, 2, 3.

5.3 Layout 1: DCE in standard operation

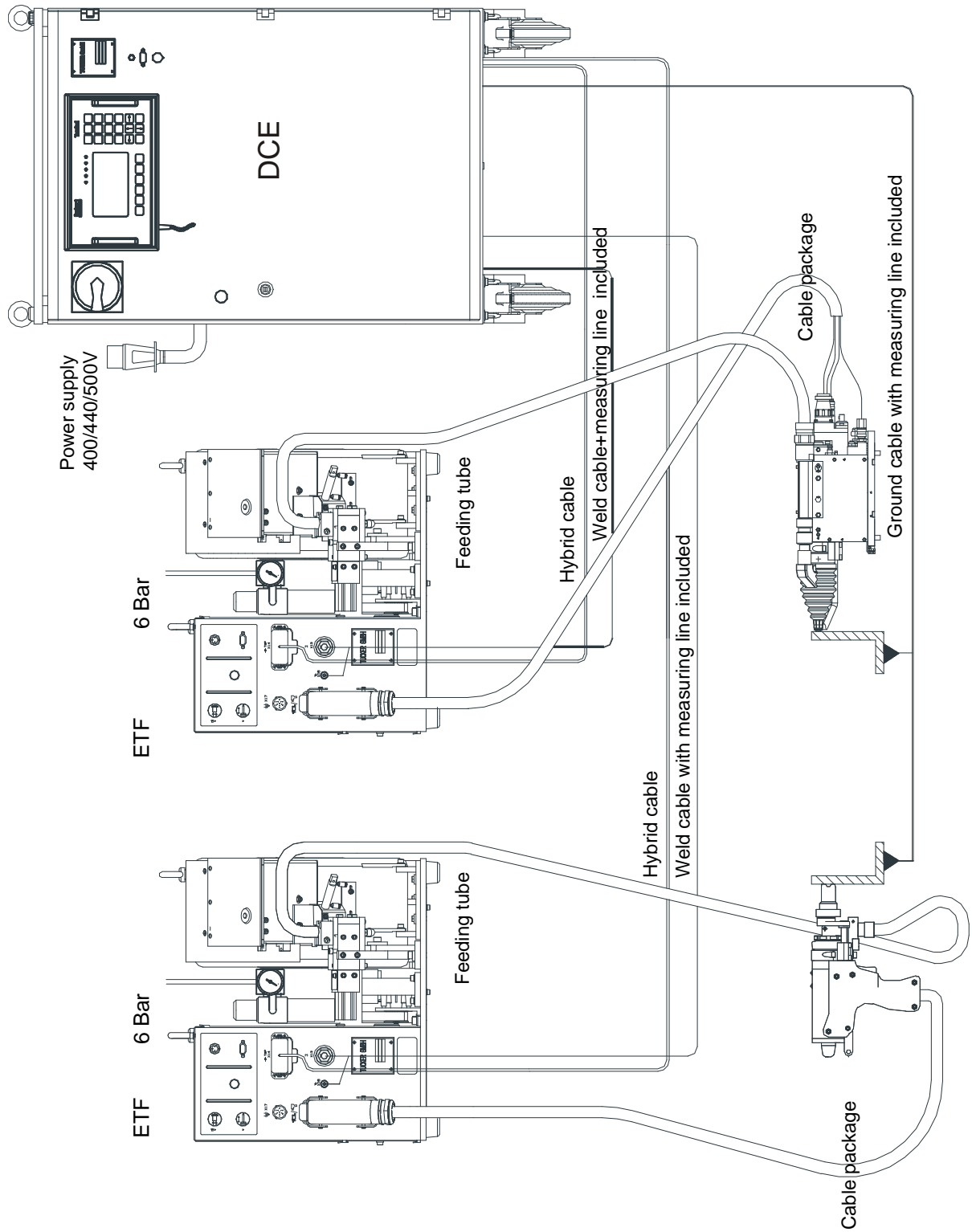

5.4 Layout 2: DCE in SD 2 Operation

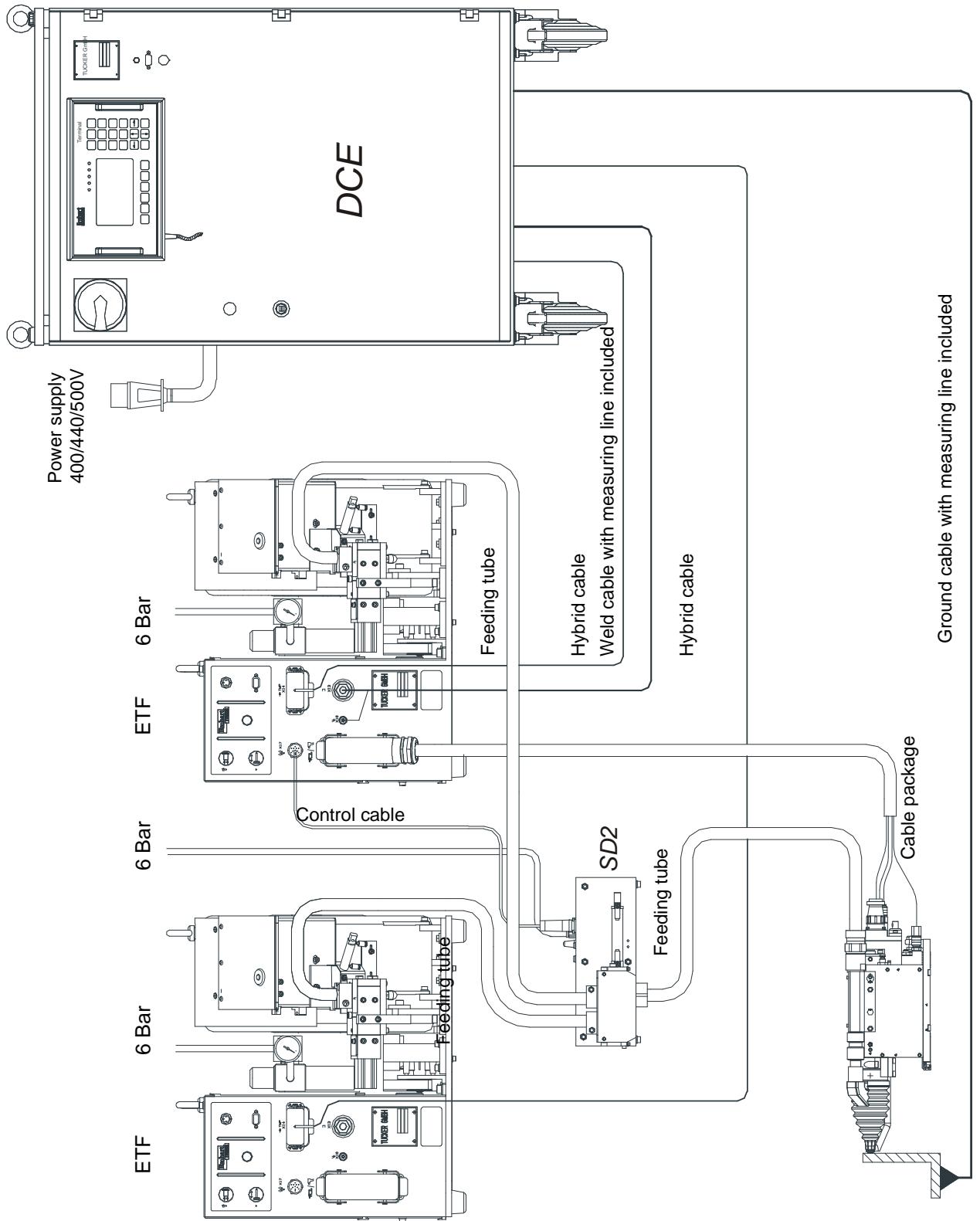

5.5 Layout 3: DCE with PKE

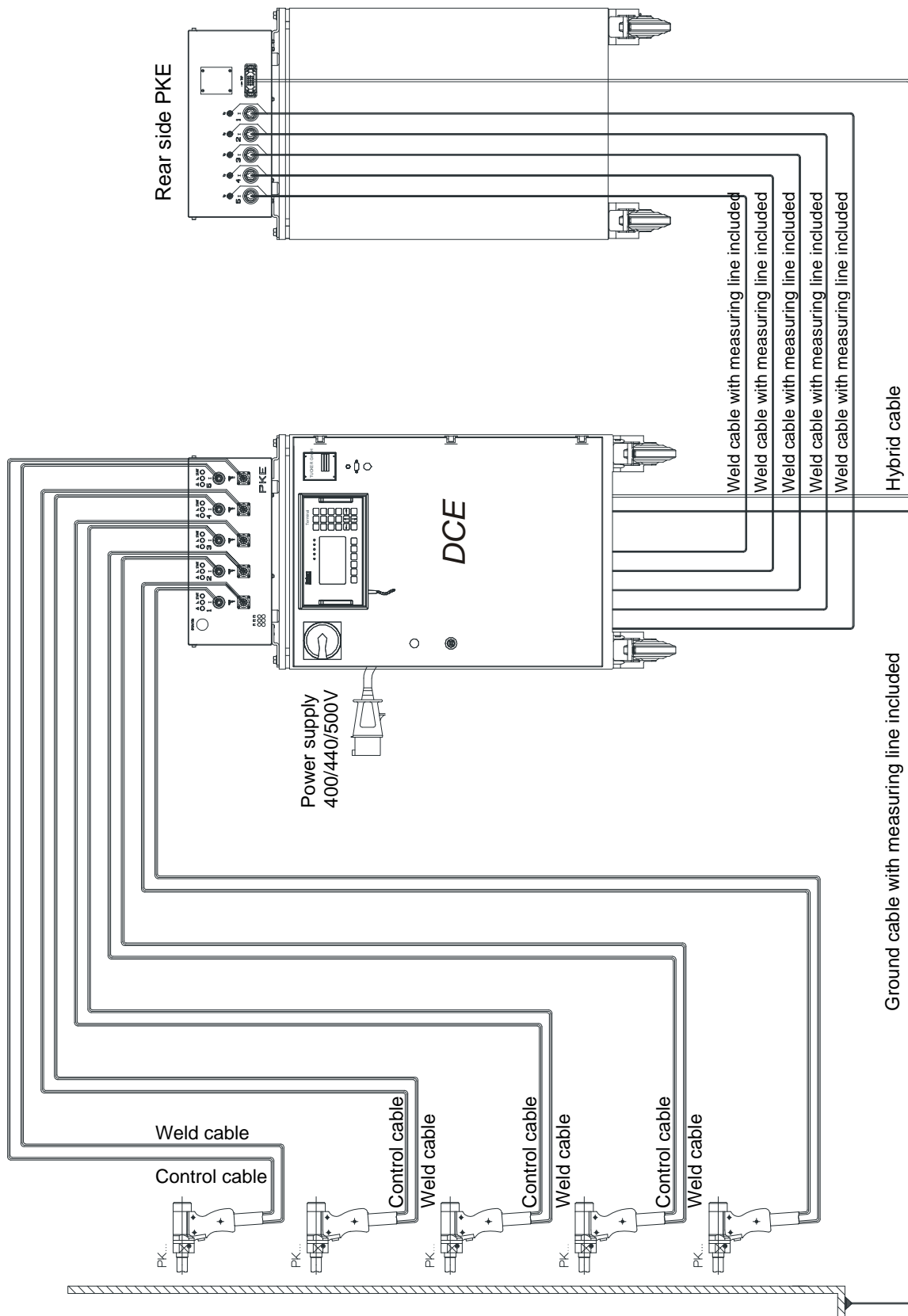

6 Display- and Control Elements

The control and power unit DCE 1500 can be optionally equipped with the following operating devices.

1. Control terminal Keypad

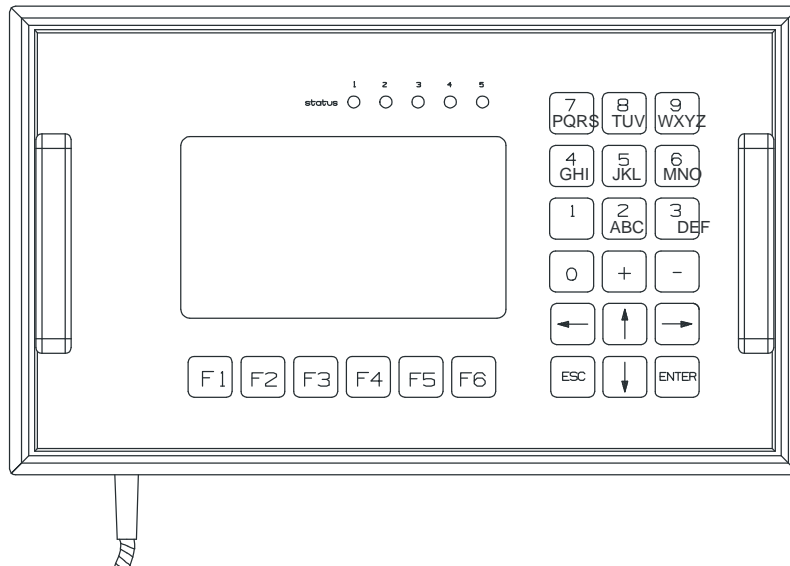

2. Control terminal Touchpad

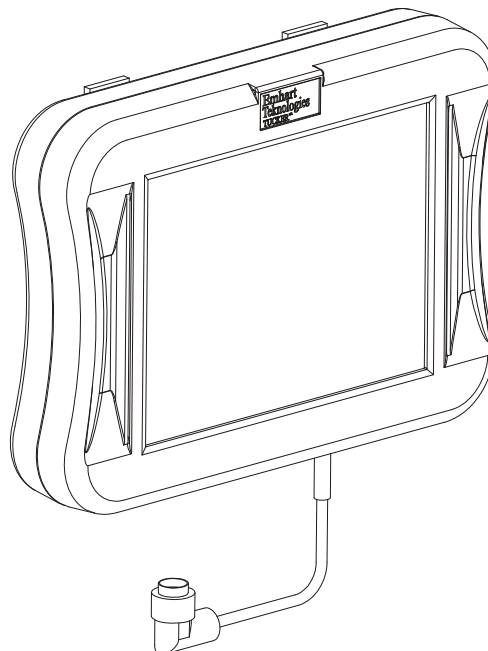

The description of the control terminal can be found in the respective programming instructions.

Conversion from Keypad to Touchpad

7 Conversion from Keypad to Touchpad

For a later conversion to control terminal Touchpad you need an additional upgrade kit with all required parts.

Update ZCPU Firmware

To use the control terminal Touchpad the software version on the ZCPU must be at least version 1.08. If an older version is installed on the CCPU you need to update the firmware before you can use the control terminal Touchpad.



Note!

The refitting parts needed for the conversion are to be discussed with and can be ordered by the TUCKER customer service.

Please regard the following points:

Exchange fuse inside the DCE



DANGER!

Opening of the appliance door as well as the inspection of the internal fuse elements is reserved for qualified electricians.

In order to avoid an electrical accident caused by contact-hazardous components the below listed sequence is peremptory when exchanging defective fuse elements.

1. Switch the DCE off at main switch!
2. Switch off the power supply externally!
3. Open the door with the special key.

Conversion from Keypad to Touchpad

The fuse F2 on the DCE power supply board E 110 327, must be exchanged against a 1A fuse. The power supply board is located at the inside of the appliance door. Place the 1A label over the 0.5A text for the replaced fuse.



pic 1

Exchange the mounting frame

The mounting frame can be attached to the suspensions outside of the appliance door where the keypad was formerly attached.



pic 2

Notes Regarding Stud Welding**8 Notes Regarding Stud Welding****NOTE!**

Stud welding causes impulsive forces of the power supply voltage. The connection of external devices to the same power system could cause malfunctions or disturbances of these devices!

Remark: Due to the welding energy source (SMPS-Technology) inserted in the DCE 1500, an increased grid-bound HF-interference level is to be faced.

To avoid malfunction of electrically connected devices and to exclude impacts of the DCE by external installations, regard the Tucker "Installation guidelines for DCE welding units" as well as the following notes:

- The power supply of the DCE with AC 400V, 440V or 500V should be always provided by a parted weld power system.
- The operator of the welding installation should keep in mind that there are preferably no combined supply voltage paths with other welding processes.
- If different welding processes are used at one work piece, ensure that these have no combined welding path of the current and no combined supply voltage path. Then a parallel welding operation is also possible.
- Welding processes with high frequency ignition and plasma welding processes have to be carried out far away from each other.
- Attend to a low-impedance ground connection. On currents of 1500 A the welding circuit should have a resistance of $R \leq 8,7 \text{ m}\Omega$.

**NOTE!**

An Excel program for calculation of the valid cross-sections and lengths of the lines can be purchased for free. Please see manufacturer address page 2.

- The ground cable on the work piece has to be installed symmetrically and not directly beside the welding site, to avoid adverse effects on the welding quality.
- The DCE 1500 has to be connected with a low-impedance protective earth, so that the leakage currents which occur on welding could flow securely.

9 DCE 1500 Start-Up



NOTE!

The start-up is exclusively reserved for the authorised and qualified service personnel!

- It must be ensured that the DCE 1500 will be placed on a stable and level surface in order to allow an unhindered opening of unit door.
- A minimum distance of 2 m to permanent heat sources must be kept in order to assure a temperature exchange with the environment.



CAUTION!

The operating voltage of the DCE 1500 has to correspond with the supply voltage of the mains power supply. On disregard damages of the DCE cannot be eliminated!

Therefore:

- Before start-up of the control and power unit compare the data on the type plate with the supply voltage of the customer.

For start-up observe the following sequence:

1. Configure the DCE-specific connectors according to chapter "Connection and Installation".
2. Connect the peripherals taking into consideration the device-specific operating manuals.
3. Switch on the DCE 1500. The type of the unit will be displayed.
4. After the main menu appears in the display switch into the menu "State" and afterwards into the submenu "System" via the cursor keys.
5. Check the configuration of the unit displayed with the connected peripherals.
6. In case the data does not match peripherals must be re-configured.

DCE 1500 Start-Up

7. In case data matches you can exit the menu "Status - System" by pressing twice the button "ESC" and switch into the menu "System configuration" - "System parameter".
8. Configure the connected devices of the outputs 1 to 5 according to their requirements.
9. Afterwards switch again into the main menu by repeated pressing of the button "ESC" and call up the menu "Programming" on.
10. Program the output related parameters in the submenu "Programming weld outlet" and the welding parameters in the submenu "Programming weld program".
11. Having terminated programming, exit the input mode with "ENTER" and return to the main menu by pressing the button "F2".
12. Now several test welds should be performed in order to verify accuracy of the programmed parameters.

**NOTE!**

Start up of the DCE is only possible after exact pin assignment of the plug "Safety circuit". The pin configuration can be taken from the operating manual "Safety Module E485A".

**NOTE!**

A programming manual for DCE/ETF is available and can be requested anytime via our after sales service. Please see manufacturer address page 2.

10 Transport, Packaging and Storing



NOTE!

The installation and initial operation is effected exclusively by personnel or by authorized persons of the manufacturer.

However, it may happen that in line with the installation and the further use operators or maintenance personnel of the operating company are consigned with the handling of packages.

In this case regard the following notes.

10.1 Security Advice for the Transport



WARNING!

Danger to life due to floating loads!

On lifting of loads there is a danger to life due to falling or uncontrolled swivelling parts.

Therefore:

- Never step under floating loads.
- Regard the specifications to the intended attachment points.
- Do not attach something to overhanging machine parts or to ears of attached components. Pay attention to a tight fit of the load-securing devices.
- Only use licensed lifting tools and load-securing devices with sufficient load capacity.
- Do not use slightly ripped or abraded ropes and belts.
- Do not attach ropes and belts to sharp-edged flanges and edges, do not knot and do not twist.

Transport, Packaging and Storing

10.2 Transport Check

Upon delivery, the equipment, including accessories, should be checked for completeness and damage. On externally visible transport damage, proceed as follows:

- Do not accept the delivery or only accept with reservation.
- Note the extent of damage on the transport documents or on the delivery note of the deliverer.
- Induce complaint.



NOTE!

Complain each defect as soon as recognized. Claims for damages can only be asserted within the effective time for complaints.

10.3 Transport

Transport of pallets with the crane

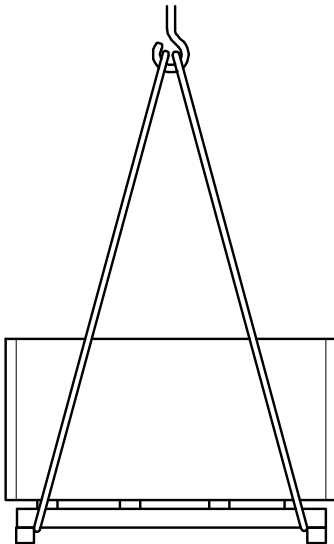

Packing pieces which are fixed on a pallet, can be transported with a crane under the following conditions:

- Crane and lifting tools must be designed for the weight of the packing pieces.
- The operator must be qualified for the operation of the crane.

Attaching:

1. Attach ropes or belts to the pallet according to the figure.
2. Check that the packing pieces will not be damaged by the load-securing devices. If necessary use other load-securing devices.
3. Start transport.

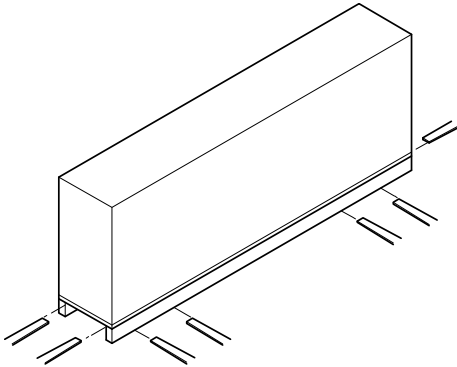
Transport of pallets with the forklift truck

Packing pieces which are fixed on a pallet, can be transported with a forklift truck under the following conditions:

- The forklift truck must be designed for the weight of the shipping units.
- The driver must be qualified for driving the forklift truck.

Attaching:

1. Drive the forklift truck with the forks between the wooden beams of the pallet.
2. Extend the forks so far that they stick out at the opposite of the pallet.
3. Ensure that the pallet cannot tilt on an excentric centre.
4. Hoist the packing piece and start the transport.

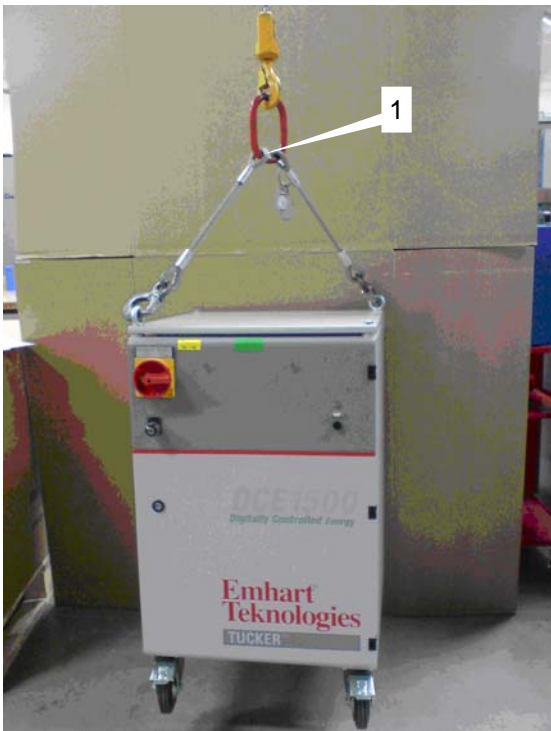
Attachment points

The following attachment point is intended:

Attachment of control and power unit

After unpacking attach the control and power unit with suitable load-securing devices (1) as shown in the figure.

10.4 Terms and Conditions for Overseas Transport



NOTE!

For onward transportation overseas use sea freight transport crate with the corresponding number of desiccant pouches for packing according to DIN 55473! The manufacturer bears no liability for damages caused by improper onward transportation.

The number of desiccant pouches depends on the size of the transport crate. Make sure that sufficient desiccant pouches are added to the transport crate.

Observe the humidity indicator of the desiccant pouch acc. to DIN 55473.



NOTE!

The desiccant pouch activity disintegration wrapping may only be removed directly before use. After removals from the packaging immediately seal tightly again.

- Pack the unit being shipped in a plastic shrink wrapping and weld.
- Place the device welded into the plastic into the transport crate and add sufficient desiccant pouches.
- Close transport crate.

Transport crate	Number of desiccant pouches
HZK 1, 2, 3, 4, 5, 6	6
HZK 7	4
HZK 8, 9, 10, 11	6
HZK 12, 13, 14	4

10.5 Packaging

The respective packaging pieces are packed according to the transport conditions to expect. Exclusively non-polluting materials were used for packaging.

The packaging shall protect the respective components against transport damages, corrosion and other damages until assembly. Therefore do not destroy the packaging and remove just shortly before assembly.

Packaging materials handling Dispose packaging material according to the respectively valid legal regulations and local directives.



CAUTION!

Damage caused to the environment due to wrong disposal!

Packaging materials are valuable raw materials and can be further used in a lot of cases or can be prepared reasonably and recycled. Therefore:

- Dispose packaging materials environmentally friendly.
- Regard the locally effective regulations for waste disposal. Charge a specialist with the disposal if applicable.

10.6 Storing

Storing of the packaging pieces

Store the packaging pieces under the following conditions:

- Do not store out of doors.
- Store dry and dust-free.
- Protect against insolation.
- Avoid mechanical vibrations.
- Stocking temperature: -25 to +55 °C.
- Relative humidity of air (not condensing): 5 to 95 %.
- On storage longer than 3 months the general condition of all parts and the packaging has to be checked regularly. Refresh or exchange the conservation if necessary.



NOTE!

Notes regarding storage which exceed the requirements mentioned here are possibly on the packaging pieces. These are to be observed respectively.

Maintenance and Cleaning

11 Maintenance and Cleaning

11.1 Safety

Personnel

- The maintenance work described can be executed by the operator, unless it is marked differently.
- Some maintenance work may only be executed by specially trained experts.
- Maintenance work on the electric installation basically may only be executed by specialists for electronics.

Improper execution of maintenance work



WARNING!

Risk of injury due to improperly executed maintenance work!

Improper maintenance can lead to heavy damage to persons and property. Therefore:

- Before start of work arrange for a sufficient space for assembly.
- If components have been removed pay attention to a correct assembly, install all fastening elements again and observe screw tightening torques.

11.2 Maintenance and Cleaning Schedule

The maintenance work essential for an optimal and failure-free operation is described in the following chapters.

In case of detection of an increased abrasion during regular checks, shorten the required maintenance intervals accordingly to the actual signs of abrasion.

If you have questions concerning maintenance work and intervals contact the manufacturer, see service address on page 2.

Interval	Wearing work	To be carried out by
daily	Check connection cables, connection plugs and connector assembly for mechanical damage and loose contacts	Operator
semi-annually	Check filter insert for contamination	Qualified personnel

11.3 Cleaning of the Filter Insert

The contamination of the filter insert is depending on the prevalent environmental conditions. For inspection proceed as follows:

- Switch off the main switch and disrupt the device from the power system.
- Loosen the two screws M 6 (arrow) on the cover of the housing aperture with a cross tip screwdriver.
- Remove the cover and the two screws.
- Loosen the connectors of all connecting cables.
- Press the push button; afterwards pull out the filter cover with the filter insert.

On a light contamination clean the filter insert with compressed air. On a heavy contamination replace the filter insert.

The assembly is carried out in reverse order.

Front view DCE without door

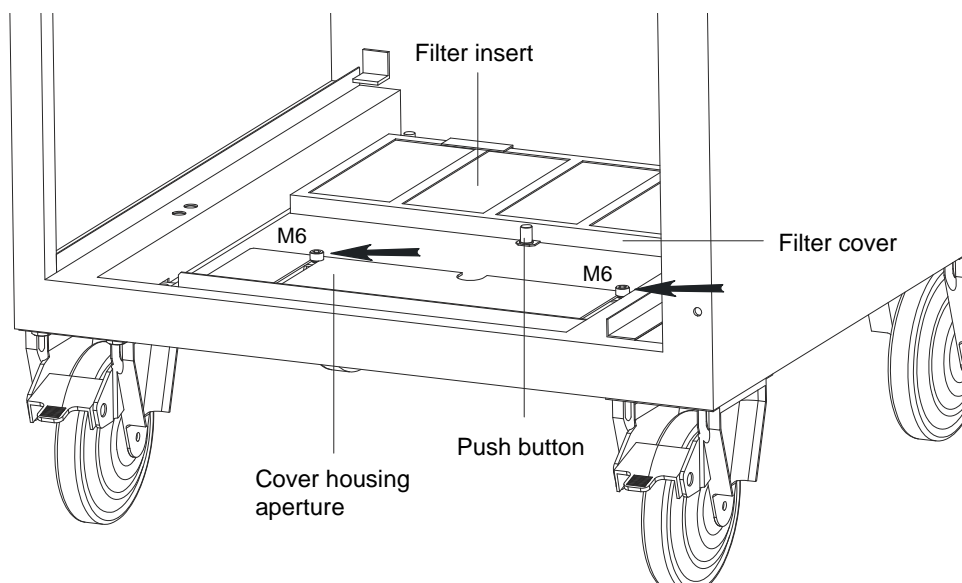

- Order number Filter insert: M 070 441

Disposal**12 Disposal**

Unless no recovery- or disposal arrangement was made disassembled parts have to be recycled:

- Scrap metals.
- Recycle plastic elements.
- Dispose sorted all the rest of the components according material properties.

**CAUTION!****Damage caused to the environment due to wrong disposal!**

Electronic waste, electronic components, lubricants and other additives are subject to treatment of hazardous waste and may be disposed only by licensed certified specialists!

The local authority or special disposal specialists provide information regarding an environmentally friendly disposal.

EC-Declaration of Conformity according to the Low Voltage Directive 2006/95/EC Annex III B

Document number: KFE DCE1500 02

Manufacturer:

TUCKER GmbH
Max-Eyth-Straße 1
35387 Gießen
Germany

Product name: DCE 1500
Control and power unit for short term drawn arc stud welding

Serial number:

Year of manufacture:

The manufacturer declares that the above-mentioned product conforms to all the applicable regulations of the Low Voltage Directive.

The above product follows the provision of the following EC Directives:

Number: 2006/95/EC Low voltage directive
2004/108/EC Electromagnetic compatibility

References of directives according to publication in Official Journal of the European Union

The following harmonised standards were applied:

EN 50 178 :1997	Electronic equipment for use in power installations
EN 60 204-1:2006	Safety of machinery — Electrical equipment of machines — Part 1: General requirements
EN 60 529 :2000	Degrees of protection provided by enclosures (IP Code)
EN 60 974-1:2005	Arc welding equipment — Part 1: Welding power sources
EN 60 974-10:2007	Arc welding equipment — Part 10: Electromagnetic compatibility (EMC) requirements

Issued by: Manfred Müller, General Manager

Location, date: Giessen,

Legally binding signature:



This declaration certifies compliance with the named Directives.

The safety instructions on the supplied product information sheet are to be followed.

