



AMKASYN AC-Servo- and Main Spindle Motors

AMK



AMK is a leading international manufacturer of electronic drives and controls. We develop, produce and distribute innovative, intelligent electronic drives. Our product range covers simple, variable speed frequency inverters as well as complete drive solutions with integrated motion control systems.

Decades of experience with solving highly complex drive tasks and continuous research and development into future-oriented technologies make us an expert partner in industrial automation.

The most modern production equipment as well as comprehensive expertise in motor design enable AMK to produce a vast variety of motors from minimum quantity series to large production lots.

To guarantee and maintain our high production quality standards, AMK has implemented quality management as certified by ISO 9001.



AMKASYN Motor Series DS, DV, DH and DW



The modular design of the AMKASYN system provides a flexible and low-cost alternative, which integrate standard components into a powerful motion control system.

The result is a precise drive and control system with all the advantages of digital control, i.e. high accuracy, safe data transfer, extensive diagnostics and exact reproducibility.

Advantages of the AMKASYN motor series

- Maintenance-free
- Sturdy
- Powerful
- Compact
- High efficiency
- Optimum power to weight ratio
- Highly dynamic response
- High overload capacity
- Winding temperature sensors as protection against overload
- Integrated encoder for speed and position control

Today's increasing demands of modern drive technology are driven by new production methods, changing automation requirements, increased demands on plant operational efficiency and highest manufacturing precision. These translate into high expectations in load capacity, performance and dynamic response that are required from a drive system, but especially from the associated motors.

AMK's high-performance motors of the AMKASYN series satisfy these requirements. These motors are engineered to offer high reliability, high dynamic response, small frame size, low rotor inertia and a largely maintenance free design.

The AMKASYN series of motors consists of the compact, highly dynamic AC-servo motor types DS and DV as well as the heavy-duty AC main spindle motor types DH and DW with high power density and precision balanced rotors.

The AMKASYN motors are optimally tuned to be used with the AMKASYN digital AC-servo inverters for multi-motor applications in the power range of 1.3 to 75 kVA and with the AMKASYN digital compact servo drives in the power range of 0.7 to 50 kVA.

Together the motors and inverters form an intelligent, digital drive system for servo and main spindle applications, which satisfies every demand.

Areas of application

The AMKASYN motors are especially suitable for use as servo and main drive motors in:

- Plant construction
- Elevator technology
- Printing machines
- Woodworking machines
- Plastic processing machines
- Warehousing and conveyor technology
- Test stands
- Process engineering
- Textile machines
- Packaging machines
- Machine tools

AMKASYN. Servo Motors DS



The synchronous servo motors DS feature compact frame sizes, high dynamic response and wide speed range. These brushless, permanent magnet AC servo motors are available in 4 and 6-pole versions. The use of rare-earth magnets provides especially high energy density and permits short term high overload for the highest demand on dynamic response. These motors can be used for speed control, positioning tasks, synchronous and stepping motor operation in combination with the digital AMK inverters type AMKASYN.

Servo Motors DS

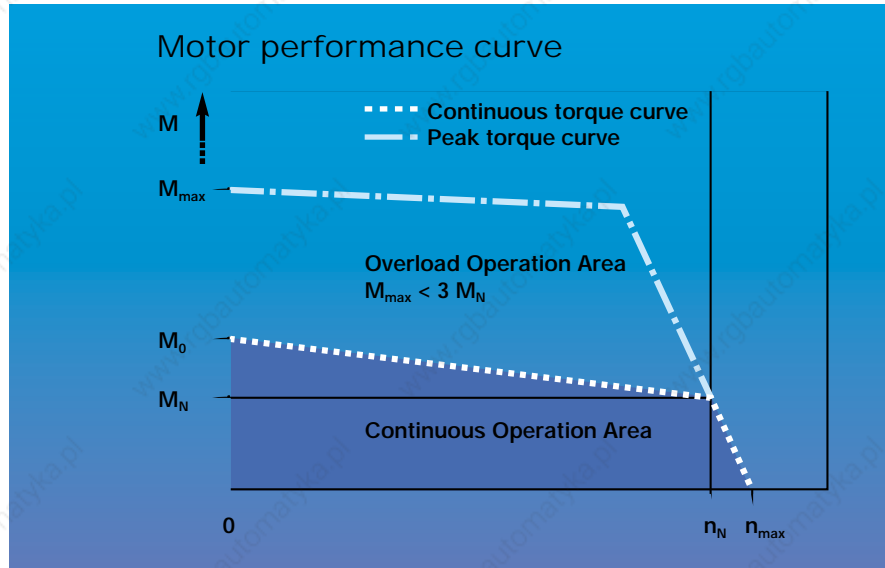

Standard version

Mounting:	B5-Metric flange
Degree of protection:	IP 54
Connections:	Plug style connector systems
Position feedback:	Resolver
Keyway:	Standard

Features

- Low maintenance
- Compact
- Lifetime lubricated bearings
- TENV (totally enclosed non-ventilated) or
- TEFC (totally enclosed fan cooled)
- High overload capacity
- High peak torque
- Sinusoidal commutation

Options

- Holding brake
- Optical position encoder
- Smooth shaft

Dimensions DS

DS 3

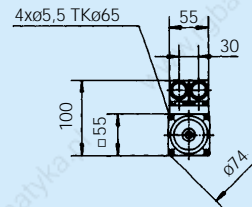
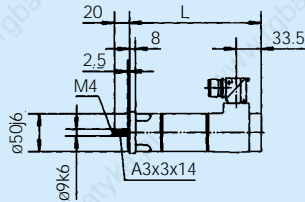

DS 4

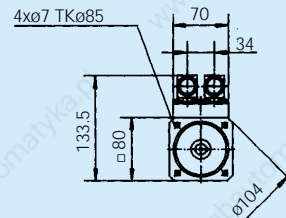
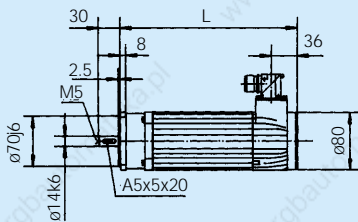

DS 5

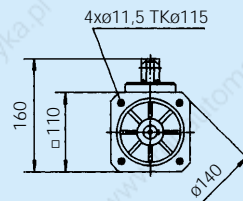
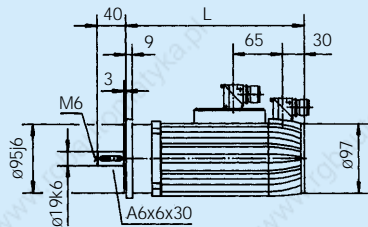

DS 7

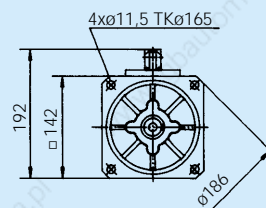
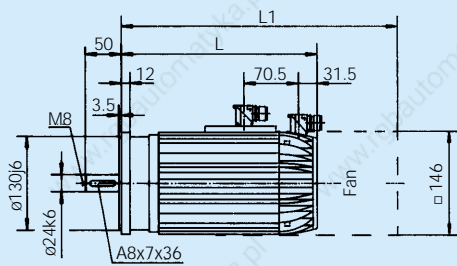

DS 10

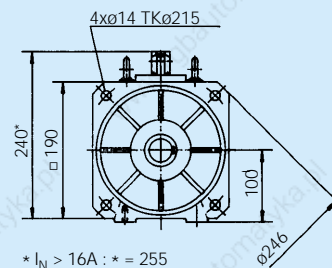
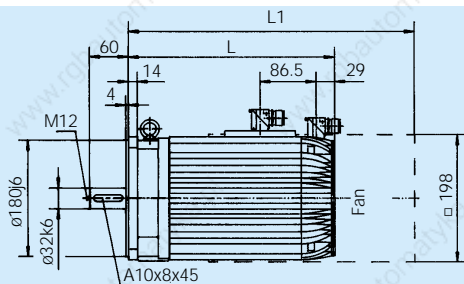

* $I_N > 16A$: * = 255

All dimensions in millimeter

Technical Data DS

Rated voltage 190 V, TENV (Totally Enclosed Non-ventilated)

Motor type	M _O [Nm]	M _N [Nm]	P _N [kW]	I _N [A]	n _N [1/min]	n _{max} [1/min]	k _T [Nm/A]	J [kgm ² · 10 ⁻³]	m [kg]	L [mm]	L _{BR} [mm]
DS 3-0.3-4-..0-6000	0.4	0.35	0.24	1.1	6600	7400	0.33	0.02	2.5	195	----
DS 4-1-6-..0- 4000	1.6	1.2	0.53	2	4200	4500	0.6	0.11	3	170	206
DS 4-2-6-..0- 4000	3.2	2.5	1.1	4	4100	4400	0.63	0.22	5	230	266
DS 5-3-6-..0- 4000	3.5	3.1	1.3	5.3	4100	4300	0.6	0.25	8.5	220	272

Rated voltage 350 V, TENV (Totally Enclosed Non-ventilated)

Motor type	M _O [Nm]	M _N [Nm]	P _N [kW]	I _N [A]	n _N [1/min]	n _{max} [1/min]	k _T [Nm/A]	J [kgm ² · 10 ⁻³]	m [kg]	L [mm]	L _{BR} [mm]
DS 3-0.3-4-..0-6000	0.4	0.35	0.24	0.6	6600	7400	0.62	0.02	2.5	195	----
DS 4-1-6-..0- 4000	1.6	1.2	0.53	1.1	4200	4500	1.1	0.11	3	170	206
DS 4-2-6-..0- 4000	3.2	2.5	1.1	2.1	4100	4400	1.2	0.22	5	230	266
DS 5-3-6-..0- 4000	3.5	3.1	1.3	2.9	4100	4300	1.1	0.25	8.5	220	272
DS 5-5-6-..0- 4000	5.7	5.2	2.2	4.7	4100	4200	1.1	0.42	10	280	332
DS 7- 7- 6-..0- 3000	8.5	6.5	2.1	4.1	3000	3200	1.6	1.2	14	265	310
DS 7-13-6-..0- 3000	15.5	12	3.8	7.1	3000	3100	1.7	2.1	23	355	400
DS 10-18-6-..0-3000	24	17	5.4	10	3050	3100	1.7	9.5	35	295	374
DS 10-30-6-..0-3000	35	28	8.9	16	3050	3100	1.8	17	48	375	454

Rated voltage 350 V, TEFC (Totally Enclosed Fan Cooled)

Motor type	M _O [Nm]	M _N [Nm]	P _N [kW]	I _N [A]	n _N [1/min]	n _{max} [1/min]	k _T [Nm/A]	J [kgm ² · 10 ⁻³]	m [kg]	L1 [mm]	L1 _{BR} [mm]
DS 7-11- 6-..F- 3000	12	11	3.5	7	3050	3200	1.6	1.2	19	377	422
DS 7-19- 6-..F- 3000	20	19	6	12	3050	3100	1.6	2.1	28	467	512
DS 10-27-6-..F-3000	29	27	8.5	16.5	3050	3100	1.6	9.5	45	420	499
DS 10-45-6-..F-3000	47	45	14	26	3050	3100	1.7	17	58	500	579

AMKASYN. Servo Motors DV



Servo motors DV are sturdy three-phase induction type asynchronous AC motors. They cannot be demagnetized and feature high overload capacity and smooth running properties. AMKASYN servo motors DV deliver practically constant torque from zero speed up to rated speed. The field weakening range allows constant output power up to 3 times rated speed. The maximum speed extends up to 10,000 rpm, the torque range from 0.3 to 26 Nm. AMKASYN servo motors DV are low-leakage design and permit fast current rise times for high dynamic response. These motors can be used for torque control, speed control, positioning and synchronous control in combination with the digital AMK inverters type AMKASYN.

Servo Motors DV

Motor performance curve

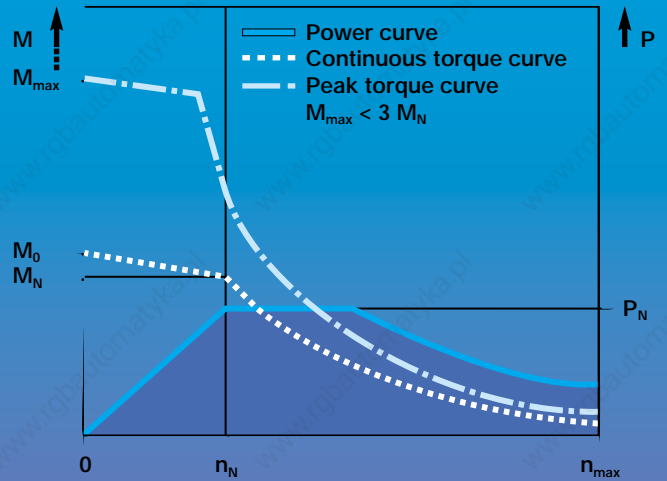

Standard version

Mounting: B5-Metric flange
Degree of protection: IP 54
Connections: Terminal box
Position feedback: Resolver
Keyway: Standard

Features

- Low maintenance
- Lifetime lubricated bearings
- TENV (totally enclosed non-ventilated) or TEFC (totally enclosed fan cooled)
- Field weakening range up to 3 times rated speed
- High speeds
- High overload capacity
- Smooth running properties

Options

- Holding brake
- Position feedback systems type A, I, T
- Smooth shaft
- Plug type connector for motor leads

Dimensions DV

DV 4

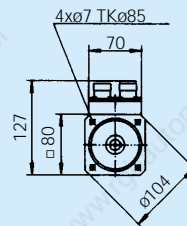
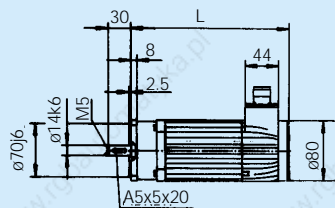

DV 5

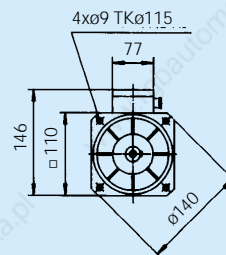
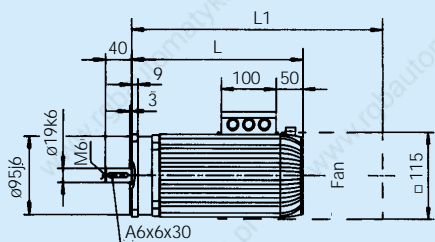

DV 7

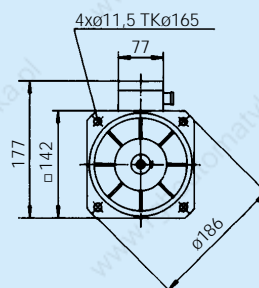
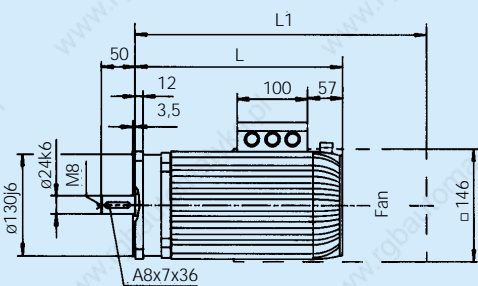

DV 10

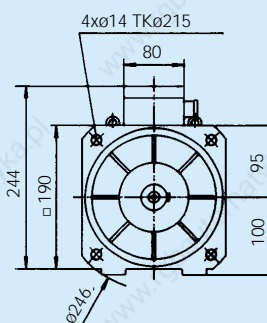
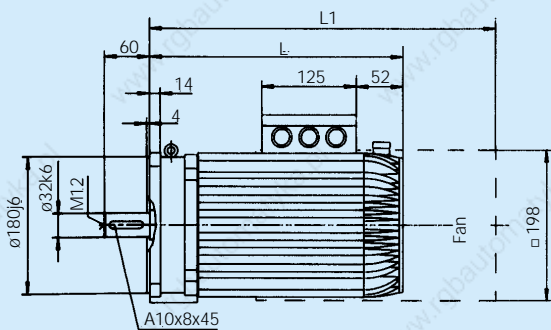

All dimensions in millimeter

Technical Data DV

Rated voltage 190 V, TENV (Totally Enclosed Non-ventilated)

Motor type	M _O [Nm]	M _N [Nm]	P _N [kW]	I _N [A]	n _N [1/min]	n _{max} [1/min]	J [kgm ² · 10 ⁻³]	m [kg]	L [mm]	L _{BR} [mm]
DV 4-0,5- 4-..0- 4000	0.6	0.3	0.13	1	4000	10000	0.05	2.5	160	196
DV 4- 1- 4-..0- 4000	0.9	0.8	0.32	2.2	4000	10000	0.09	4.5	210	246
DV 5- 1- 4-..0- 4000	1.25	1.1	0.49	2.4	4000	10000	0.2	6.5	198	250
DV 5- 2- 4-..0- 4000	2.2	2	0.83	4	4000	10000	0.37	7.5	248	300

Rated voltage 190 V, TEFC (Totally Enclosed Fan Cooled)

Motor type	M _O [Nm]	M _N [Nm]	P _N [kW]	I _N [A]	n _N [1/min]	n _{max} [1/min]	J [kgm ² · 10 ⁻³]	m [kg]	L ₁ [mm]	L _{1BR} [mm]
DV 5- 2- 4-..F- 3000	2.2	2.1	0.7	3.7	3000	10000	0.2	8.5	301	353
DV 5- 4- 4-..F- 3000	4.1	3.9	1.2	6.1	3000	10000	0.37	9.5	351	403

Rated voltage 350 V, TENV (Totally Enclosed Non-ventilated)

Motor type	M _O [Nm]	M _N [Nm]	P _N [kW]	I _N [A]	n _N [1/min]	n _{max} [1/min]	J [kgm ² · 10 ⁻³]	m [kg]	L [mm]	L _{BR} [mm]
DV 4-0,5-4-..0- 4000	0.6	0.3	0.13	0.55	4000	10000	0.05	2.5	160	196
DV 4- 1- 4-..0- 4000	0.9	0.8	0.32	1.2	4000	10000	0.09	4.5	210	246
DV 5- 1- 4-..0- 4000	1.3	1.1	0.49	1.3	4000	10000	0.2	6.5	198	250
DV 5- 2- 4-..0- 4000	2.2	2	0.83	2.2	4000	10000	0.37	7.5	248	300
DV 7- 4- 4-..0- 1500	4.3	4	0.63	1.7	1500	8000	1.1	10	216	261
-3000	4	3.4	1.1	2.6	3000	8000	1.1	10	216	261
DV 7- 6- 4-..0- 1500	6.7	6	0.95	2.4	1500	8000	1.8	13.5	261	306
-3000	6.1	5	1.55	3.6	3000	8000	1.8	13.5	261	306
DV 10-7- 4..0- 1500	9.5	9	1.4	3.1	1500	5500	7.4	34	271	350
3000	7.6	7	2.2	5.5	3000	5500	7.4	34	271	350
DV 10-11-4-..0- 1500	15	14	2.2	4.8	1500	5500	10	41	311	390
3000	11.8	11	3.5	7.5	3000	5500	10	41	311	390

Rated voltage 350 V, TEFC (Totally Enclosed Fan Cooled)

Motor type	M _O [Nm]	M _N [Nm]	P _N [kW]	I _N [A]	n _N [1/min]	n _{max} [1/min]	J [kgm ² · 10 ⁻³]	m [kg]	L ₁ [mm]	L _{1BR} [mm]
DV 5- 2- 4-..F- 3000	2.2	2.1	0.7	2	3000	10000	0.2	8.5	301	353
DV 5- 4- 4-..F- 3000	4.1	3.9	1.2	3.3	3000	10000	0.37	9.5	351	403
DV 7- 8- 4-..F- 1500	7.4	7	1.1	3.5	1500	8000	1.1	13	328	373
-3000	7.4	6.8	2.1	5.2	3000	8000	1.1	13	328	373
DV 7-12- 4-..F- 1500	11.5	10.5	1.7	4.9	1500	8000	1.8	18.5	373	418
-3000	11	10	3.1	7.3	3000	8000	1.8	18.5	373	418
DV 10-19-4-..F- 1500	23.5	22	3.5	8.1	1500	5500	7.4	44	396	475
-3000	20	19	6	14	3000	5500	7.4	44	396	475
DV 10-26- 4-..F- 1500	32	30	4.6	10.5	1500	5500	10	51	436	515
3000	27	26	8.3	19	3000	5500	10	51	436	515

AMKASYN. Main Spindle Motors DH

AMKASYN main spindle motors DH are highly dynamic and sturdy three-phase asynchronous motors and are especially suitable as main drives or high power servo drives. These motors feature a constant power speed range of 1:3, with rated power up to 38 kW and rated torque up to 240 Nm. 200 to 300% of rated torque can be delivered briefly up to rated speed. The heavy duty design and strengthened bearings permit high radial loads. AMKASYN main spindle motors DH in addition display outstanding servo properties. They can be used in speed control, position and synchronous control in combination with the digital AMK inverters type AMKASYN.



Standard version

Mounting: B5 Metric flange
 Degree of protection: IP 54
 Motor connection: Terminal box
 Position feedback: Optical sine wave encoder, Type I
 Keyway: Standard
 Airflow direction: Towards output shaft

Features

- Low maintenance
- Heavy duty bearings
- TEFC – totally enclosed fan cooled; airflow towards the output shaft (optional reverse airflow)
- High overload capacity
- Outstanding servo properties

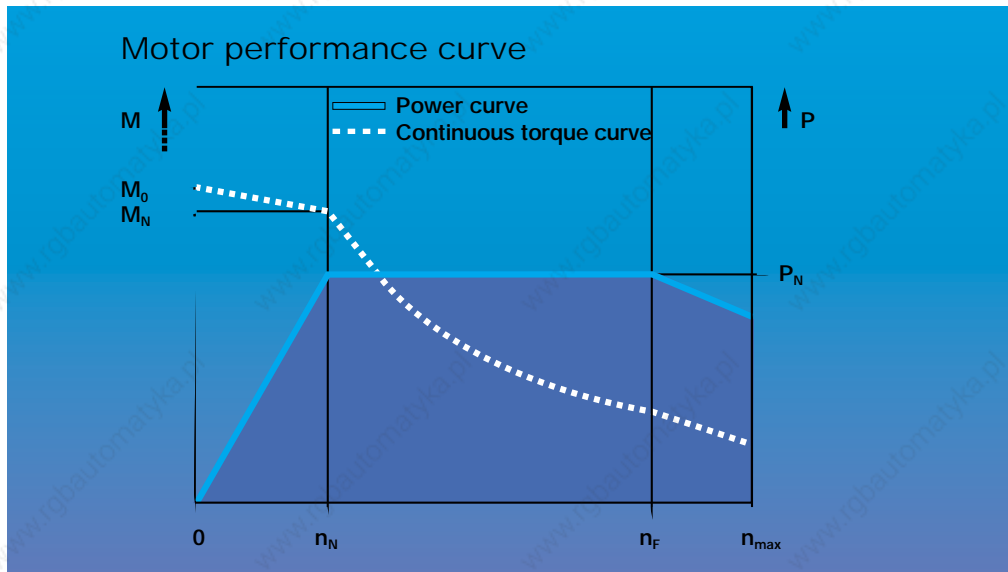

Options

- Holding brake
- Shaft end without keyway
- Reverse fan airflow
- Higher vibration severity grade
- Tighter runout tolerances

Technical Data DH

Rated voltage 350 V

Motor type	M _O [Nm]	M _N [Nm]	P _N [kW]	I _N [A]	n _N [1/min]	n _F [1/min]	n _{max} [1/min]	J [kgm ² · 10 ⁻³]	m [kg]	L1 [mm]	L1 _{BR} [mm]
DH 10- 40-4...F-1500	43	40	6.3	15	1500	4500	5500	18	57	500	579
DH 10- 55-4...F-1800	56	53	10	22.5	1800	3600	5500	22	71	600	679
DH 13- 60-4...F-1500	68	60	9.5	23	1500	3000	5000	46	90	520	610
DH 13-100-4...F-1500	100	95	15	32	1500	3000	5000	80	125	630	720
DH 13-120-4...F-1500	125	110	17.5	39	1500	3000	5000	95	145	680	770
DH 13-150-4...F-1800	155	148	28	63	1800	3200	5000	120	180	780	870
DH 16-180-4...F-1500	190	180	28	62	1500	3000	4500	160	220	725	870
DH 16-240-4...F-1500	255	240	38	78	1500	3000	4500	210	265	825	970

Dimensions DH

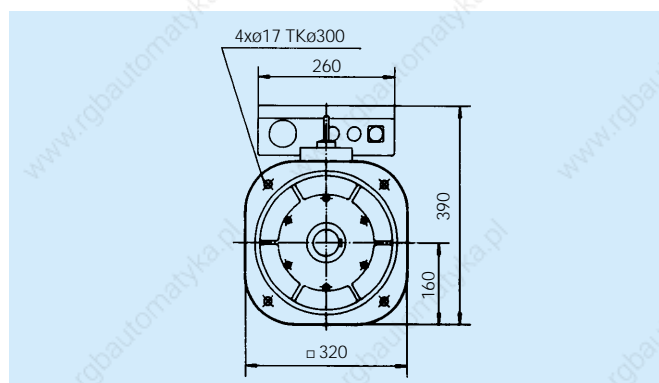
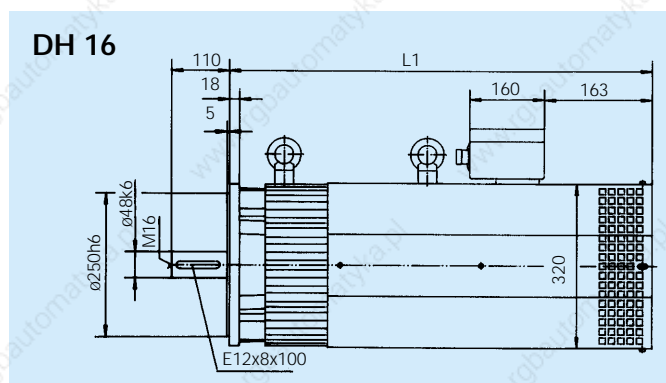
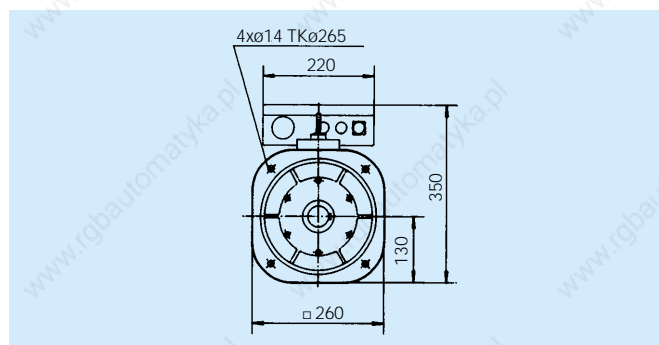
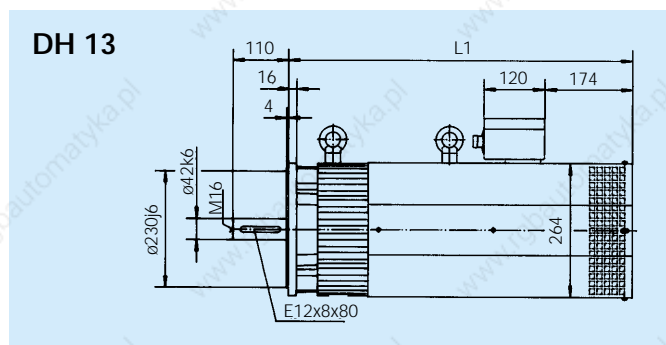
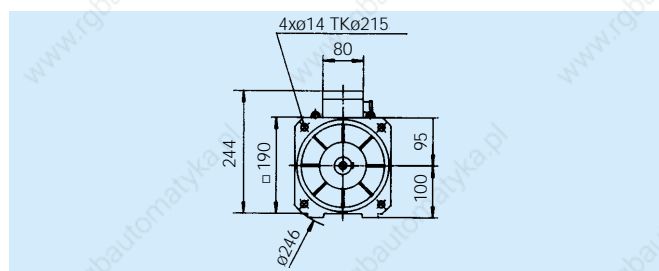
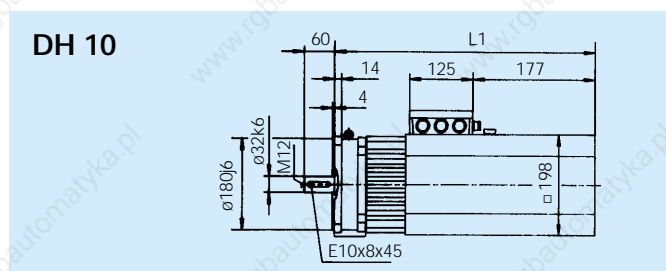

All dimensions in millimeter

AMKASYN. Liquid-cooled Main Spindle Motors DW

These liquid-cooled three-phase asynchronous motors feature compact frame sizes at high power density.

Due to the liquid-cooled design of these motors the thermal influences on the immediately surrounding components and area are reduced to a minimum as compared to fan cooled designs. The created waste heat can be reclaimed easily for other inhouse processes.

AMKASYN main spindle motors DW feature a constant power speed range of 1:3, rated power up to 28kW and rated torque up to 150 Nm. The heavy duty design and strengthened bearings permit high radial loads. AMKASYN main spindle motors DW in addition display outstanding servo properties. They can be used in speed control, position and synchronous control in combination with the digital AMK inverters type AMKASYN.



Standard version

Mounting:	B5 Metric flange
Degree of protection:	IP 54
Motor connection:	Terminal box
Position feedback:	Optical sine wave encoder, Type I
Keyway:	None (smooth shaft)

Features

- Low maintenance
- Compact
- High power density
- No thermal influence on surrounding components
- Heavy duty bearings
- High overload capacity
- Outstanding servo properties

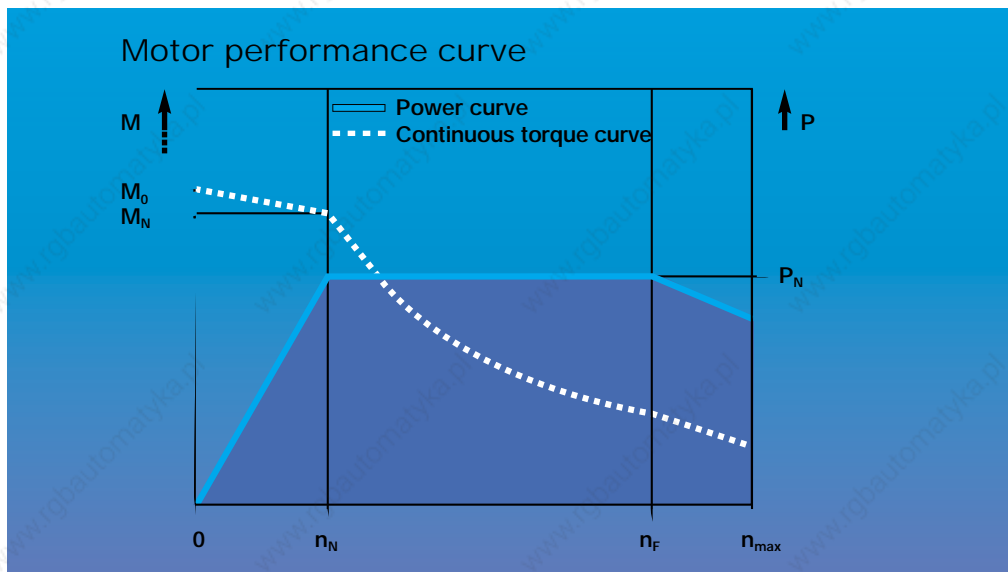

Options

- Shaft with keyway
- Higher vibration severity grade
- Tighter runout tolerances

Liquid cooling requirements

- Inlet temperature 15 to 30 degrees Celsius
- Maximum input pressure: 1 bar
- Closed circuit cooling system
- In case of water cooling please follow AMK recommendations for the water quality.

Technical Data DW

Rated voltage 350 V

Motor type	M _O [Nm]	M _N [Nm]	P _N [kW]	I _N [A]	n _N [1/min]	n _F [1/min]	n _{max} [1/min]	J [kgm ² · 10 ⁻³]	m [kg]	Q [l/min]	ΔT [K]	L [mm]	L _{BR} [mm]
DW 7- 17-4-..W- 3000	14	13	4	11	3000	5500	5500	1.7	22	1.5	15	345	----
DW 7- 33-4-..W- 3000	25	23	7.2	20	3000	5500	5500	3.2	30	2	15	450	----
DW 10- 40-4-..W- 1500	43	40	6	15	1500	4500	5500	18	68	2	15	435	555
DW 10- 55-4-..W- 1800	56	53	10	22	1800	3600	5500	22	85	2	15	535	655
DW 13- 60-4-..W- 1500	68	60	9.5	23	1500	3000	5000	46	80	2	20	360	455
DW 13-100-4-..W- 1500	100	95	15	32	1500	3000	5000	80	115	2	20	465	560
DW 13-150-4-..W- 1800	155	148	28	63	1800	3200	5000	120	170	2.5	20	615	710

Dimensions DW

DW 7

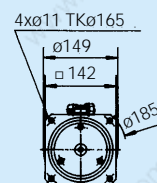
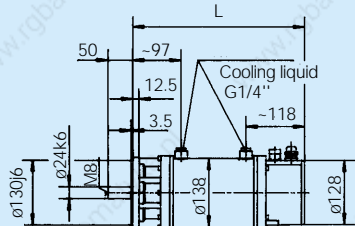

DW 10

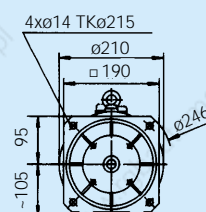
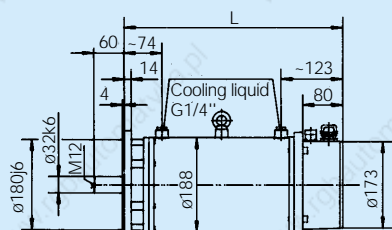

DW 13

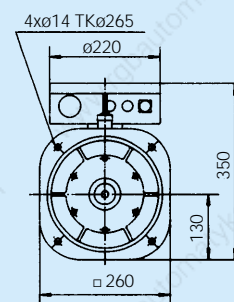
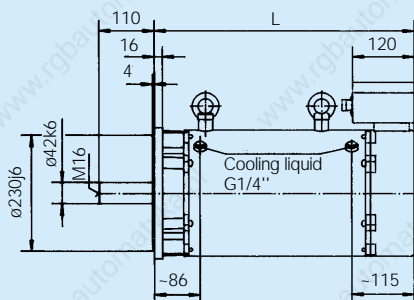

All dimensions in millimeter

Motor Connection

DV, DH and DW motors feature terminal box connections for motor leads, fan and holding brake. The motors of the DS series and optionally of the DV series feature plug-style connectors. Connection cables with the cor-

responding cross-sections can be purchased preassembled. Shielded cables must be used for EMC reasons.

Terminal box types and terminal block wiring

Motor type	Terminal box size	Terminal block components	Cable strain relief	Cable dia. in mm	Wire size [mm ²]	I _L * [A]
DV5/ DV7	KG 1	3 x M6 and 6 x M4	1 x PG13.5 and 2 x PG11	5-12 5-10	4 x 1	9.6
DW7	----	6 x M5	1 x PG13.5 and 1 x PG11	5-12 5-10	4 x 1	9.6
DV10/ DH10	KG 3	3 x M6 and 6 x M4	1 x PG21 and 2 x PG11	11-17.5 5-10	4 x 1.5 / 2.5 / 4	12.2 / 16.5 / 23
DW10	----	3 x M6 and 6 x M4	1 x PG29 and 1 x PG11	18-27 7.5-12	4 x 1.5 / 2.5 / 4	12.2 / 16.5 / 23
DH13/ DW13	KG 4	6 x M6 and 9 x M4	1 x PG29 and 2 x PG11	18-25 5-10	4 x 6/10	29 / 40
DH16	KG 5	6 x M10 and 9 x M4	1 x PG29 and 2 x PG11	18-25 5-10	4 x 16	53

*The current values I_L for the connection cable refer to applications according to EN 60204-1:1992 in the cable laying type B2, or according to DIN 46200 for connection bolts.

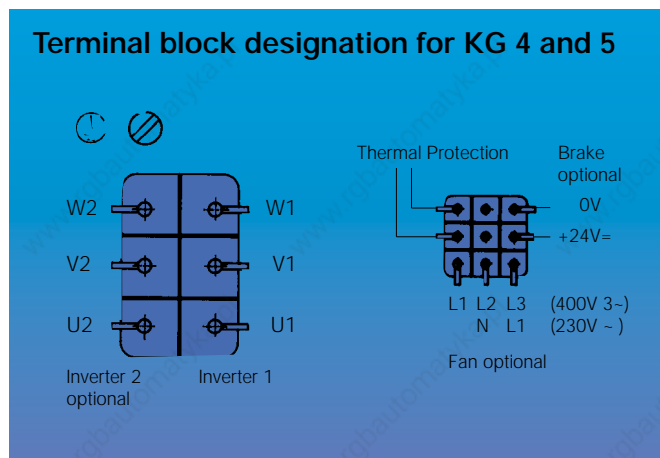
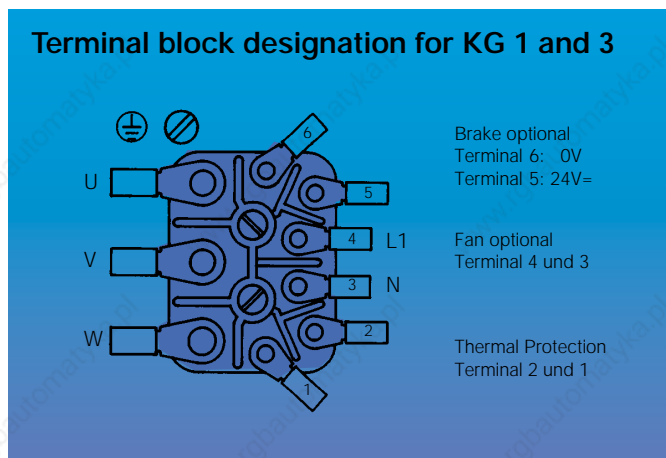

Connector types

Motor size	Connector size (cable dia in mm)	Wire size [mm ²]	I _L * [A]
DS3-10, DV4-10	BG 1 (7,5-18,5)	4 x 1.5 + 4 x 0.25	12.2
DS10, DV10	BG 1.5 (9-25)	4 x 4.0 + 4 x 0.75	23
DS10, DV10	BG 1.5 (9-25)	4 x 6.0 + 4 x 0.75	29

*The current values I_L for the connection cable refer to applications according to EN 60204-1:1992 in the cable laying type B2

Dimensions of the motor connector and connection wiring

Power connector size BG 1

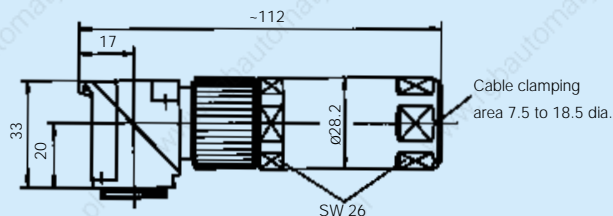

All dimensions in millimeter

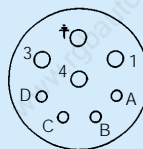

Connection assignment when viewed onto the motor socket

Designation	Connection
A	Temperature sensor
B	Temperature sensor
C	Brake +
D	Brake 0 Volt
1	Motor phase u
3	Motor phase w
4	Motor phase v
⊕	PE ground

Power connector size BG 1.5

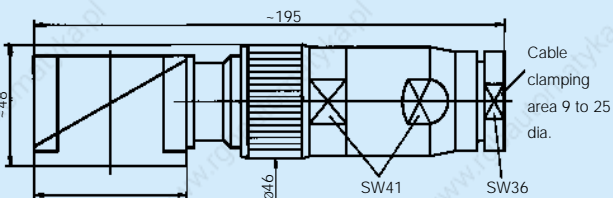

All dimensions in millimeter

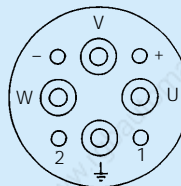

Connection assignment when viewed onto the motor socket

Designation	Connection
u	Motor phase u
v	Motor phase v
w	Motor phase w
1	Temperature sensor
2	Temperature sensor
+	Brake +
-	Brake 0 V
⊕	PE ground

Socket and connector for external fan.

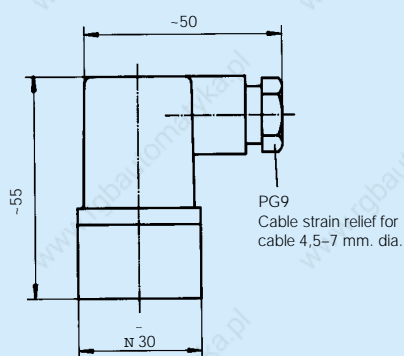

All dimensions in millimeter

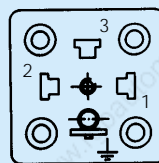

Connection assignment when viewed onto the motor socket

Designation	Connection
1	L1
2	N
3	-----
⊕	PE ground

Position Feedback Systems



Feedback types

The motors can be equipped with different position feedback systems. Depending upon the type of feedback used, the maximum speed of the motor is limited accordingly.

Type	Description	Max. speed [rpm]
R	Resolver	15.000
I	Optical sine wave encoder 1000 (optional 1024) periods/revolution	6.000
T	Optical absolute value encoder max. 4096 revolutions 512 periods/revolution	6.000
A	Magnetic sine wave encoder 100 (50) periods/revolution	60.000

Pin-outs of the socket of the position feedback signal.

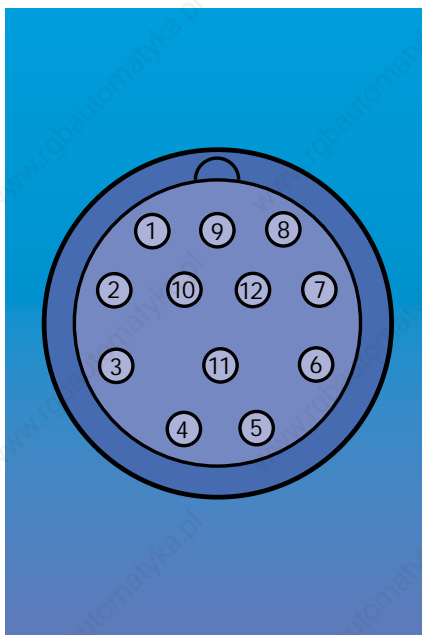

Pin	Feedback types			
	R	I	T	A
1	+Sin	G2N	G2N	G2N
2	-Sin	G2I	G2I	G2I
3	+Cos	G1N	G1N	G1N
4	-Cos	G1I	G1I	G1I
5	-	-	-	-
6	-	GND	GND	GND
7	-	-	-	-
8	SSS	-	SSS	-
9	+UREF	G0N	+RS485	G0N
10	-UREF	G0I	-RS485	G0I
11	-	05P	09P	05P
12	-	-	-	-

Connection assignment when viewed onto the encoder socket

Description of pin-out symbols

G0N	Reference pulse
G0I	Reference pulse inverted
G1N	Channel 1
G1I	Channel 1 inverted
G2N	Channel 2
G2I	Channel 2 inverted
05P	Supply 5 V=, max. 250 mA
09P	Supply 9 V=, max. 150 mA
SSS	Shield

+ Sin	Resolver sine
- Sin	Resolver sine inverted
+ Cos	Resolver cosine
- Cos	Resolver cosine inverted
+ UREF	Resolver supply signal
- UREF	Resolver supply signal inverted
+ RS485	T encoder, interface
- RS485	T encoder, interface

Technical Data of External Fan and Holding Brake

External fan

The external fans on the motors must be connected to a separate supply voltage. Up to motor size 10 the external fans are driven by single-phase 230V, 50/60 Hz AC-motors, from motor size 13 they are driven by three-phase 400V, 50/60 Hz motors (see table). The air flow is in the direction of the output shaft in the DS and DV motors. The DH motors can be designed either for air flow in the direction of the output shaft (standard) or reverse (optional). With reverse air flow the stated performance data must be reduced by approx. 15%. Please inquire for accurate data. Sufficient clearance for the air supply or discharge is required.



Motor type	External fan data	
	U _F [V]	I _F [A]
DV 5	1 x 230	0.25
DS 7	1 x 230	0.1
DV 7	1 x 230	0.1
DS 10	1 x 230	0.6
DV 10	1 x 230	0.6
DH 10	1 x 230	0.6
DH 13	3 x 400	0.5
DH 16	3 x 400	0.7

Holding brake

The motors can be equipped optionally with holding brakes. These are not suitable as service brakes. The brakes are lifted with 24V DC input. In the case of changed operating conditions, the operating

instructions of the brake manufacturer must be observed.

Note: For the maximum speed of the motor the maximum speed of the brake must also be considered.

Motor type	Holding brake data					
	M _{BR} [Nm]	U _{BR} [V]	I _{BR} [A]	J _{BR} [kgm ² ·10 ⁻³]	n _{maxBR} [1/min]	m _{BR} [kg]
DS 4, DV 4	1.2	24 ≅	0.35	0.007	12000	0.5
DS 5, DV 5	2.5	24 ≅	0.5	0.04	10000	1
DV 7 with M _N ≤ 6 Nm	5	24 ≅	0.55	0.1	10000	1.5
DV 7 with M _N > 6 Nm	11	24 ≅	0.55	0.1	10000	1.5
DS 7	11	24 ≅	0.55	0.1	10000	1.5
DS 10, DV 10	20	24 ≅	0.95	1	10000	2.5
DH 10	40	24 ≅	1.4	3.2	8000	4.5
DH 13	100	24 ≅	2.3	1.6	3500	15
DH 16	130	24 ≅	3.2	3.8	3500	23

General Technical Data

Ambient temperature:

+5 ... +40 degrees Celsius. At higher ambient temperatures up to maximum 60 degree Celsius the rating data must be reduced by 1% per 1 Kelvin temperature rise.

Installation altitude:

Up to 1000 m above sea level. In operation above 1000 m altitude, ambient temperatures corresponding to DIN VDE 0530 Table 4 shall be used as basis.

Humidity:

Maximum 85% relative humidity, non-condensing

Degree of protection:

IP 54. Higher degree of protection on request

The stated maximum speeds apply for the IP 54 version with seal ring.

Rating data:

Refer to 100 Kelvin temperature rise in the windings. The test motor is mounted using a thermally insulating flange.

Insulating material class:

F according to DIN VDE 0530.

Thermal protection:

PTC resistor, cold resistance approx. 150-800 Ohm

Bearings:

Ball bearings, lifetime lubricated

Axial eccentricity run-out:

N according to DIN 42955

Balancing grade:

G2,5 corresponding to VDI 2056

Vibrational grade:

N according to DIN ISO 2373

Painting:

RAL 9005, flat black

Cooling:

Non-ventilated or fan-cooled; airflow toward output shaft. Reverse airflow as option.

Abbreviations

Motor tables

Character	Unit	Description
M_0	Nm	Zero speed torque
M_N	Nm	Rated torque
P_N	kW	Rated power
n_N	rpm	Rated speed
n_F	rpm	Speed limit for constant rated power
n_{max}	rpm	Maximum speed
U_N	V	Rated voltage
I_N	A	Rated current
J	kgm ²	Rotor inertia
m	kg	Motor weight
k_T	Nm/A	Torque constant ($M=I \cdot k_T$)
Q	l/min	Rated flow rate
ΔT	K	Temperature rise of the liquid at point of rated operation
L	mm	Length of non-ventilated motor
L_1	mm	Length of fan cooled motor
L_{BR}	mm	Length of motor including brake
L_{1BR}	mm	Length of fan cooled motor including brake

Holding brake

M_{BR}	Nm	Holding torque
n_{maxBR}	rpm	Brake maximum speed
U_{BR}	V	Rated voltage 24V≅ (unregulated)
I_{BR}	A	Brake rated current
J_{BR}	kgm ²	Brake moment of inertia
m_{BR}	kg	Weight of the brake, total motor weight is $m + m_{BR}$

External fan

U_F	V	External fan rated voltage
I_F	A	External fan rated current

Important Notes

- Motors can reach surface temperatures above 100 degrees Celsius during operation. Before touching the motor check the surface temperature to avoid injury.
- In the case of motors with keyways and freely rotating shaft ends, the key must be removed or secured against being thrown off.
- Before opening the terminal box or pulling out or plugging in a connector on the motors, ensure that there is no voltage at the termination end. Voltage can be present at the connections even when the motor is not moving. If not complied with injuries or death may occur.
- A low-resistance connection of the motor housing to the PE ground bus in the control cabinet is required for trouble free and safe operation of the motors.
- Pounding or uncontrolled impact of force onto the motor shaft during transport, storage and installation of the motors in the machine can lead to damage of the bearings and shaft.
- Inadmissible axial and radial loads lead to reduction of the bearing life. Bearing load diagrams are available on request.
- When using couplings, attention to correct assembly of the coupling components has to be observed. Alignment errors or offset of the coupling can lead to premature destruction of bearings and of the coupling.
- All motors listed may not be connected directly to the main power lines. The motors are intended exclusively for operation on AMK inverter systems.

AMK – your competent
partner in drive
and control systems



- AC servo and main drives
- Linear-motion drives
- Joint-drive modules
- Variable-speed AC drives and 3-phase AC drives
- Custom-designed special motors
- Built-in and geared motors
- Frequency inverters

AMK

Arnold Müller GmbH & Co. KG
Antriebs- und Regeltechnik
Postfach 13 55
D-73221 Kirchheim/Teck
Gaußstraße 37–39
D-73230 Kirchheim/Teck
Phone: 0 70 21/50 05-0
Telefax: 0 70 21/50 05-199
E-Mail: Info@amk-antriebe.de
<http://www.amk-antriebe.de>

AMK Drives and Controls Ltd.
Moulton Park Business Center
Redhouse Road
Moulton Park
Northampton NN3 6AQ
UK
Phone: 0 16 04/49 78 06
Telefax: 0 16 04/49 78 09
E-Mail: amkdrives@compuserve.com

AMK Drives and Controls Inc.
5631 South Laburnum Avenue
Richmond, Virginia 23231
USA
Phone: 08 04-222-03 23
Telefax: 08 04-222-03 39
E-Mail: amkusadrives@richmond.net
<http://www.amkdrives.com>