



CLM 01.3-A

Four-Axis Positioning Control

User's Manual

DOK-CONTRL-CLM01.3*A**-ANW1-AE-P



**Copyright © 1993 and 1998 by Indramat Division,
The Rexroth Corporation.
All Rights Reserved.**

**Publication Number IA 74794
Revision C, May 1998**

Information in this document is subject to change without notice. No part of this manual may be reproduced or transmitted in any form, by any means, electronic, mechanical; including photocopying and recording, for any purpose without the express written permission of Indramat.

FOREWORD

Special Notations:

Special notations are used in this manual to assist the reader in identifying unique conditions or information that is important. Three categories of notations are listed below in ascending order of importance.

Note: A **NOTE** is a tip, suggestion or emphasized procedure for operating the equipment.

Caution: A **CAUTION** appears when a condition exists that could cause operating faults or damage to the equipment.

Warning: **WARNING** statements identify conditions that could cause bodily harm and/or severe damage to the equipment if the operator is not careful operation the equipment. A **WARNING** will typically describe the potential hazard, its possible effect, and measures that must be taken to avoid the hazards.

Please **NOTE** that due to variations found in the operating conditions of certain applications and their working environments, the notations in this manual cannot identify all potential problems or hazards. Caution and discretion must always be used in operating machinery and especially when using electrical power. Equipment should only be installed and operated by trained personnel.

* *Repair and Training services are available from* **REXROTH INDRAMAT**.

The Rexroth Corporation
Indramat Division
5150 Prairie Stone Parkway
Hoffman Estates, Illinois 60192

Phone (847) 645-3600 ■ FAX (847) 645-6201

RECORD OF REVISIONS

Revision Level	Date	Description of Change
A	2/93	Initial Release
B	9/93	Update to 3000 blocks of memory
C	3/98	New parameter descriptions Changes to existing parameters New drawings in Appendix F

TABLE OF CONTENTS

FOREWORD.....	iii
RECORD OF REVISIONS.....	iv
TABLE OF CONTENTS.....	v
1. GENERAL DESCRIPTION.....	1-1
1.1 About this Manual.....	1-3
1.1.1 Hardware and Software Support	1-3
1.1.2 How To Use This Manual.....	1-3
1.2 System Features	1-5
1.3 Physical Description of the CLM Control	1-10
1.4 Brief Operational Description	1-12
1.5 Specifications	1-13
1.5.1 Physical.....	1-13
1.5.2 Control Specifications	1-13
1.5.3 Options.....	1-14
2. CONTROLS AND INDICATORS.....	2-1
2.1 Keypad and Display.....	2-1
2.2 Data Entry Keys.....	2-3
2.3 Display Screens	2-4
2.3.1 Scrolling Through Display Screens.....	2-4
2.3.2 Parameter Mode Display Screens.....	2-11
2.3.3 Software Version / Control Status / Fault Display Screens	2-12
2.3.4 System I/O Display Screens	2-13
2.3.5 Counter Display Screen	2-19
2.3.6 Axis Position Display Screen	2-19
2.3.7 Mode/Tasks Display Screens	2-22
2.3.8 Edit Mode Display Screen.....	2-23
2.4 Lower Front Panel	2-25
3. FUNCTIONAL DESCRIPTION OF I/O CONNECTIONS.....	3-1
3.1 Signal Definitions.....	3-1
3.2 Interface Descriptions	3-2
3.2.1 Operating Mode Selection	3-5
3.2.2 Servo System Operation Enables.....	3-6
3.2.3 Safety Interlocks.....	3-7

3.2.4 Normal Operation Signals.....	3-8
3.2.5 Axis Homing.....	3-9
3.2.6 Manual Operations.....	3-12
3.2.7 Fault/Diagnostic Monitoring.....	3-13
3.2.8 Feed Monitoring / Program Interruption.....	3-13
3.2.9 Special Functions.....	3-15
3.3 Input Signal Descriptions.....	3-17
3.3.1 Parameter Mode Select.....	3-17
3.3.2 Automatic Mode Select.....	3-17
3.3.3 Emergency Stop.....	3-18
3.3.4 Cycle Start.....	3-18
3.3.5 Cycle Stop.....	3-19
3.3.6 Amplifier Ready (Axis #1 through #4).....	3-19
3.3.7 Clear (External).....	3-19
3.3.8 Jog Forward (Axis 1 through 4).....	3-20
3.3.9 Jog Reverse (Axis 1 through 4).....	3-20
3.3.10 Restart Select.....	3-20
3.3.11 High Speed Registration Mark Detect.....	3-21
3.4 Output Signal Descriptions.....	3-22
3.4.1 Manual Mode Indicator.....	3-22
3.4.2 Automatic Mode Indicator.....	3-22
3.4.3 Parameter Mode Indicator.....	3-22
3.4.4 Amplifier Enable, RF (Axis #1 through #4).....	3-23
3.4.5 Brake Release (Axis #1 through #4).....	3-23
3.4.6 System Fault Indicator.....	3-24
3.4.7 Restart Possible Indicator.....	3-24

4. PARAMETERS.....4-1

4.1 Description of Parameter Sets.....	4-1
4.2 Parameter List.....	4-2
4.3 Entering the Parameters.....	4-3
4.3.1 Displaying of Decimals.....	4-5
4.3.2 Auxiliary Inputs/Outputs.....	4-5
4.3.3 Unit of Measurement.....	4-6
4.4 Linear or Rotary Operation.....	4-7
4.5 Parameter Descriptions.....	4-8
4.5.1 Parameter Ax00 - Maximum Velocity, Axis 1 - 4.....	4-9
4.5.2 Parameter Ax01 - Jog Velocity, Axis 1 - 4.....	4-10
4.5.3 Parameter Ax02 - Acceleration, Axis 1 - 4.....	4-11
4.5.4 Parameter Ax03 - Position Gain (KV Factor) Axis 1 - 4.....	4-12
4.5.5 Parameter Ax04 - Incremental Encoder Data, Axis 1 - 4.....	4-13
4.5.6 Parameter Ax05 - Absolute Encoder Data, Axis 1 - 4.....	4-14
4.5.7 Parameter Ax06 - Position Tolerance, Axis 1 - 4.....	4-15
4.5.8 Parameter Ax07 - Position Pre-Signal, Axis 1 - 4.....	4-16
4.5.9 Parameter Ax08 - Feed Constant, Axis 1 - 4.....	4-17
4.5.10 Parameter Ax09 - Direction of Operation, Axis 1 - 4.....	4-18
4.5.11 Parameter Ax10 - Homing, Incremental Encoder, Axis 1 - 4.....	4-19
4.5.12 Parameter Ax10 - Homing, Absolute Encoder, Axis 1 - 4.....	4-20

4.5.13 Parameter Ax11 - Homing Offset, Axis 1 - 4	4-21
4.5.14 Parameter Ax12 - Homing Acknowledgement, Axis 1 - 4	4-22
4.5.15 Parameter Ax13 - Travel Limit, Minimum Value, Axis 1 - 4	4-23
4.5.16 Parameter Ax14 - Travel Limit, Maximum Value, Axis 1 - 4	4-24
4.5.17 Parameter Ax15 - Special Functions, Axis 1 - 4 (Position Loop Reset/Velocity Achieved/Master Encoder Averaging)	4-25
4.5.18 Parameter Ax16 - Rotary Axis Gear Ratio, Axis 1 - 4.....	4-27
4.5.19 Parameter Ax17 - Second Acceleration Rate, Axis 1 - 4.....	4-28
4.5.20 Parameter Ax18 - Single/Dual Speed Motor Positioning (Max), Axis 1 - 4.....	4-29
4.5.21 Parameter Ax19 - Single/Dual Speed Motor Positioning (Min), Axis 1 - 4.....	4-30
4.5.22 Parameter Ax20 - Feed Angle Monitoring, <u>Feed Interrupt</u> , Axis 1 - 4	4-31
4.5.23 Parameter Ax21 - Drive Input Sensitivity, Axis 1 - 4.....	4-32
4.5.24 Parameter Ax22 - Monitor Window, Axis 1 - 4	4-33
4.5.25 Parameter Ax23 - Follow / Synchronous / Measuring Wheel.....	4-36
4.5.26 Parameter Ax24 - Delay Axis x	4-38
4.5.27 Parameter Ax25 - Jerk constant	4-39
4.5.28 Parameter B000 - Enable Axis 2.....	4-40
4.5.29 Parameter B001 - Enable Axis 3.....	4-41
4.5.30 Parameter B002 - Enable Axis 4.....	4-42
4.5.31 Parameter B003 - Serial Interface Information	4-43
4.5.32 Parameter B004 - Serial Interface Information	4-44
4.5.33 Parameter B005 - Memory Display.....	4-45
4.5.34 Parameter B006 - Start Task 2 & 3.....	4-46
4.5.35 Parameter B007 - Display Language / Decimal Place / Keypad Lockout	4-47
4.5.36 Parameter B008 - Variations.....	4-49
4.5.37 Parameter B009 - Start Program Block - Task 4, Task 5	4-50
4.5.38 Parameter B010 - Clear Outputs	4-50
4.5.39 Parameter B011 - Manual Vector	4-51
4.5.40 Parameter B012 - Program Interrupt Vector.....	4-53
4.5.41 Parameter B013 - Analog Input	4-54
4.5.42 Parameter B014 - Restart Vector.....	4-56
4.5.43 Parameter B015 - Cycle Time.....	4-57
4.5.44 Parameter B016 - Measuring Wheel Encoder.....	4-57
4.5.45 Parameter B017 - Measuring Wheel Encoder, Lines/Revolution.....	4-58
4.5.46 Parameter B018 - Measuring Wheel Feed Constant	4-58
4.5.47 Parameter B019 - Measuring Wheel Offset	4-58

5. PROGRAMMING.....5-1

5.1 Positioning	5-1
5.2 Auxiliary Inputs/Outputs	5-2
5.2.1 Programming Inputs/Outputs.....	5-2
5.2.2 Inputs/Outputs Signal Definition	5-2
5.3 Multi-tasking	5-4
5.4 Start of the Program	5-4
5.5 End of the Program	5-4
5.6 Programming Mode	5-4
5.7 General Format	5-5
5.8 Command Summary	5-6

5.8.1 Positioning Commands	5-6
5.8.2 Position Support Commands	5-7
5.8.3 Branch Commands	5-8
5.8.4 Jump Commands	5-8
5.8.5 Auxiliary Functions	5-9
5.8.6 Counter Commands	5-9
5.8.7 Timer Commands.....	5-9
5.8.8 Other Commands.....	5-10
5.9 Command Descriptions.....	5-11
5.10 ACC Acceleration Change.....	5-12
5.11 AEA Auxiliary Output ON/OFF	5-13
5.11.1 AEO Acceleration Override	5-14
5.12 AKN Acknowledge Single Input.....	5-16
5.13 AKP Parallel Acknowledgment Input.....	5-17
5.13.1 ANC Analog Input Compare	5-19
5.14 APE Activate Parallel Outputs.....	5-20
5.15 APJ Activate Parallel Output, then Jump	5-22
5.16 ATS Acknowledge Output Status	5-24
5.17 BAC Branch And Count	5-25
5.18 BCA Branch Conditional on Acknowledgment (Output-Dependent).....	5-27
5.19 BCB Binary Conditional Branch (Inputs)	5-28
5.20 BCD BCD Conditional Branch.....	5-30
5.21 BCE Branch Conditional on Input.....	5-32
5.22 BIO Branch Input/Output Compare	5-33
5.23 BMB Branch on Multiple Binary Outputs	5-34
5.24 BPA Branch on Parallel Acknowledgments (Outputs)	5-35
5.25 BPE Branch on Parallel Inputs	5-36
5.26 BPT Branch on Position Test.....	5-37
5.27 BZP Branch If the Target Position Exceeds the Position Limit	5-38
5.28 CID Change Instruction Data.....	5-39
5.29 CIO Copy Input/Output to Output	5-41
5.30 CLA Clear Axis (Absolute Encoder Value).....	5-43
5.31 CLC Clear Counter	5-43
5.32 COC Cam Output Control	5-44
5.33 CON Continuous Operation.....	5-46
5.34 COU Count	5-47
5.35 CST Change Subroutine Stack	5-48
5.35.1 DEC Deceleration Change.....	5-50
5.36 FAK Factor All Motions.....	5-51
5.37 FMS Follow Master	5-53
5.38 FOL Follow (Axis Synchronization)	5-54
5.39 FUN Functions.....	5-55
5.40 HOM Home Axis.....	5-56
5.41 JMP Jump Unconditional.....	5-57
5.42 123 Jump to Subroutine	5-57
5.43 JST Jump and Stop	5-58
5.44 JTK Jump in Task.....	5-59
5.45 KDI Copy Position Difference.....	5-60
5.45.1 MLO Material Length Output.....	5-61
5.46 NOP No Operation (Blank Block).....	5-62

5.47 PBK Position Break	5-63
5.48 POA Position Absolute	5-64
5.49 POI Position Incremental.....	5-65
5.50 POM Position On Memory	5-66
5.51 PSA Position Absolute (With In-Position Signal)	5-67
5.52 PSI Position Incremental (With In-Position Signal).....	5-68
5.53 PSM Position On Memory (with In-Position Signal)	5-69
5.54 PST Position Test.....	5-70
5.55 REF Referencing (Detect Registration Mark Input)	5-71
5.56 REP Registration Position Limit (Search Limit Branch).....	5-72
5.57 RMI Registration Mark Interrupt.....	5-73
5.58 RSV Restart Vector	5-76
5.59 RTM Rotary Table Mode	5-77
5.60 RTS Return from Subroutine.....	5-78
5.61 SAC Set Absolute Counter	5-79
5.62 SIN Sine Oscillation.....	5-80
5.63 SO1 Scanning of Inputs and Modifying a Length (Special Option #1)	5-81
5.64 SO2 Position Correction Via Analog Input	5-84
5.64.1 STO Send Information To Outputs	5-87
5.65 VCA Velocity Change Absolute.....	5-89
5.66 VCC Velocity Change Command.....	5-90
5.67 VEO Velocity Override Command	5-91
5.68 WAI Wait (Time Delay)	5-93
5.69 WRI Write in Absolute Position (Teach Command)	5-94

6. INSTALLATION/START-UP..... 6-1

6.1 Unpacking / Parts Inventory	6-1
6.2 Mounting Cabinet	6-3
6.3 Power	6-4
6.4 Cable Routing.....	6-4
6.5 Transformer - Heat Dissipation	6-4
6.6 Hardware Installation.....	6-5
6.7 Electrical Installation.....	6-5
6.8 CLM Connectors	6-6
6.9 Pre-Operation Start Up Tests.....	6-9
6.10 Connections.....	6-9
6.11 Inputs.....	6-10
6.12 Outputs	6-11
6.13 Power-up	6-11
6.14 Parameter Entry	6-12
6.15 Program Entry	6-13
6.16 Axis Jogging In Manual Mode	6-15
6.17 Automatic Mode Operation	6-15

7. SERIAL INTERFACE..... 7-1

7.1 Connector Wiring (DB-25).....	7-2
7.1.1 Signal Level Requirements.....	7-3

7.1.2 Serial Cable Configurations	7-4
7.2 Data Format.....	7-5
7.2.1 Word Length.....	7-5
7.2.2 Parity Check	7-5
7.2.3 Baud Rate.....	7-6
7.2.4 Interface Mode.....	7-6
7.3 CLM Control String Protocol.....	7-7
7.3.1 First (1) Control String Character (Transmission Type).....	7-7
7.3.2 Second (2) Control String Character (CLM Unit # Identifier).....	7-8
7.3.3 Third (3) Control String Character (Information Type).....	7-8
7.3.4 Other Important Control Characters.....	7-9
7.4 Information Characters.....	7-10
7.5 CHECKSUM Calculations	7-11
7.6 Sending Information to the CLM.....	7-12
7.6.1 Sending Program Blocks to the CLM.....	7-12
7.6.2 Sending Parameters to the CLM.....	7-13
7.7 Information Request	7-16
7.7.1 Requesting a Program Block from the CLM.....	7-16
7.7.2 Requesting a System Parameter from the CLM.....	7-17
7.7.3 Requesting System Status from the CLM.....	7-18
8. DIAGNOSTICS AND TROUBLESHOOTING.....	8-1
8.1 SYSTEM RELATED ERROR CODES	8-1
8.2 AXIS RELATED ERROR CODES.....	8-5
A. APPENDIX A: LA PROGRAMMING NOTES.....	A-1
A.1 LA PROGRAMMING NOTES	A-1
A.2 Axis Homing for the CLM.....	A-1
A.2.1 General	A-1
A.2.2 Normal Homing.....	A-1
A.2.3 Homing Without Using the Homing Routine	A-3
A.2.4 Homing to a Switch.....	A-3
A.2.5 Homing to the Marker Pulse	A-6
A.3 Aligning a Stegmann Absolute Encoder to a CLM	A-7
B. DOCUMENTATION, EKITS AND CABLES.....	B-1
B.1 Manuals and Drawings	B-1
B.2 CLM-01.3 E-Kits.....	B-2
B.3 CLM 01.3A Cable Sets.....	B-3

C. CLM DISPLAY SCREEN MAP.....	C-1
D. CLM PROGRAM COMMANDS/FORMAT.....	D-1
D.1 CLM-01.3-A / LA01.3-01.x Alphabetical Listing of Program Command Formats.....	D-1
E. PARAMETER INPUT SHEETS.....	E-1
E.1 Axis 1 Parameter Input Sheet.....	E-1
E.2 Axis 2 Parameter Input Sheet.....	E-2
E.3 Axis 3 Parameter Input Sheet.....	E-3
E.4 Axis 4 Parameter Input Sheet.....	E-4
E.5 "B" System Parameters Input Sheet.....	E-5
F. DRAWINGS AND SCHEMATICS.....	F-1
F.1 Encoder Input Connections, Axis 1.....	F-2
F.2 Encoder Input Connections, Axis 2.....	F-3
F.3 Input Connections.....	F-4
F.4 Output Connections.....	F-5
F.5 Power Supply Connections.....	F-6
F.6 Interface Connections.....	F-7
F.7 RS 232 / RS 485 Interface Connections.....	F-8
F.8 RS 485 (w / SOT) Interface Connections.....	F-9
F.9 Input Connections.....	F-10
F.10 Input Connections.....	F-11
F.11 Output Connections.....	F-12
F.12 Command Value / Drive Enable and I/O Connections.....	F-13
F.13 Encoder Inputs, Axis 3.....	F-14
F.14 Encoder Inputs, Axis 4.....	F-15
F.15 CLM-TVM / TDM 1.2 & 2.1.....	F-16
F.16 CLM-TVM / TDM 1.2 & 2.1.....	F-17
F.17 CLM-TVM / TDM 1.2 & 2.1.....	F-18
F.18 CLM-TVM / TDM 3.2.....	F-19
F.19 CLM-TVM / TDM 3.2.....	F-20
F.20 CLM-KDV / KDS.....	F-21
F.21 CLM-KDV / KDS.....	F-22
F.22 CLM-RAC 3.1.....	F-23
F.23 CLM-RAC 2.2.....	F-24
F.24 CLM-NAM / TVD / DDS.....	F-25
F.25 CLM-NAM / TVD / DDS (Incremental).....	F-26
F.26 CLM-NAM / TVD / DDS (Absolute).....	F-27
F.27 CLM-DKS / DAE (Incremental).....	F-28
F.28 CLM-DKA / DAA (Absolute).....	F-29
F.29 CLM-DKC (Incremental).....	F-30
F.30 CLM-DKC (Absolute).....	F-31

G. INSTALLATION DRAWINGS.....	G-1
G.1 Keypad Replacement Face Plate Panel Dimensions (AM 1037).....	G-1
H. CLM TYPE CODE DESCRIPTIONS.....	H-1
H.1 CLM Hardware Type Code Description.....	H-1
H.2 Software Type Code Description.....	H-2
H.3 IDS Hardware Type Code Description	H-3
H.4 IDS Software Type Code Description.....	H-3
H.5 SOT Hardware Type Codes.....	H-4
H.6 SOT Software Type Codes	H-5

1. GENERAL DESCRIPTION

The CLM is a modular, microprocessor-based positioning control. This multi-tasking, user programmable unit is designed for precision motion control of to four axes. The CLM module is illustrated in Figure 1.1. The CLM controls an Indramat maintenance-free AC servo system to drive a ballscrew or some other positioning device. This is a closed-loop feedback system which provides precise control of speed and position at all times. The CLM/servo system is used for a variety of positioning applications.

Typical applications include:

Roll feeds

Thermoforming machines

Handling equipment

Automatic bending machines.

Packaging machines

Linear gantry robots

Woodworking machines

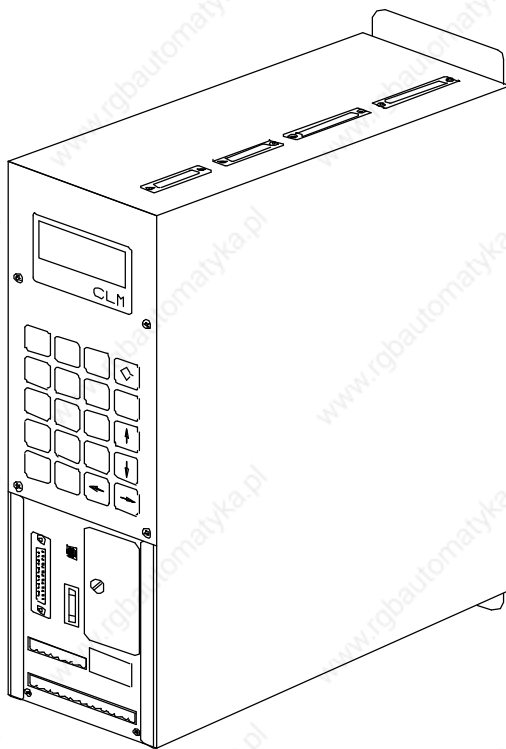

Figure 1-1 CLM Positioning Control Module

The extensive program command set permits the CLM to perform even complex processing tasks. It can do multi-tasking, operating two motion programs and a background PLC program simultaneously. The CLM can be programmed both on-line, and off-line.

The CLM can be used in remote operation, where it is controlled by the customer's line control, usually a computer or a programmable controller, which controls operation of the whole machine. The function of the line control is to convey commands and to receive information from the CLM. This can be accomplished using discrete I/O connections to the CLM.

The standard CLM has 24 inputs and 19 outputs, which are available for assignment by the user. Options allow increasing the inputs to 88 and the outputs to 51. In many applications, the CLM provides sufficient machine control without the use of an external line control. Other information, such as programs, parameters, and system status can be communicated (two way) between the CLM and a host device, such as a computer, programmable controller or Indramat SOT, via a multi-format serial communications port.

A typical system consists of an Indramat CLM control, a MAC AC Servo motor (with integral encoder for position feedback), and a Servo controller (amplifier). Complete interconnect cable sets are also available from Indramat. The components are chosen to best fit the required application. Figure 1.2 is a block diagram of a typical system configuration.

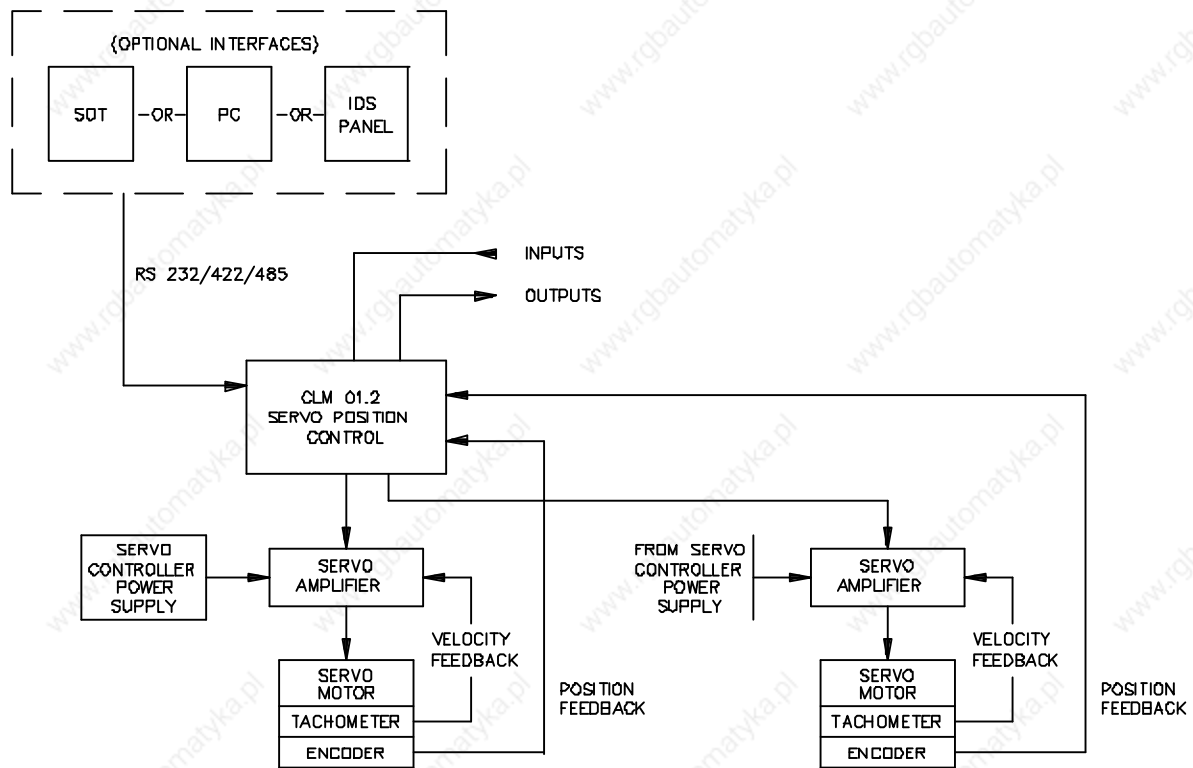

Figure 1-2 Block Diagram

1.1 About this Manual

This document is written for machine builder and end user operating personnel. It explains how to interface, install, setup and operate the Indramat CLM Positioning Control with LA software.

1.1.1 Hardware and Software Support

This manual describes the CLM-01.3-A hardware, used with LA01.3-02.x software (x=minor revision number).

Indramat provides assistance for any problems you may encounter with this system. Your first source of information should be this manual. To report a problem or request assistance, call Indramat at [800] 860-1055. Ask for Technical Service. You may also write or FAX to the following:

Rexroth-Indramat

Attn.: Technical Service

5150 Prairie Stone Parkway

Hoffman Estates, Illinois 60192

FAX Number: [847] 645-1201

1.1.2 How To Use This Manual

The manual is organized such that Chapters 1 and 2 describe the control and its operation. These chapters, plus Chapter 8 on diagnostics, will be sufficient for most operating personnel. Chapters 3-8 provide functional description, installation, setup, parameter entry, programming, and diagnostic and troubleshooting information required by the machine builder and setup personnel.

Chapter 1. General Description	Describes the CLM control and the features which make it well suited for motion control. Describes and illustrates various options. Lists specifications.
Chapter 2. Controls & Indicators	Describes the controls and indicators of the CLM and its options.
Chapter 3. Functional Description	Describes all pre-defined, plus several user definable, input and output signals and the various interfacing and operating modes of the CLM. This information is necessary for interfacing the CLM to the machine builder's equipment, control panel design and troubleshooting.

Chapter 4. Parameters	Describes all user-entered parameters required to adapt the CLM to the mechanical and electrical characteristics of each application.
Chapter 5. Programming	Describes all program commands provided in the CLM for the user to create the executable program, as desired for the application.
Chapter 6. Installation/Start-up	Describes procedures for installing a CLM control system. Provides an example of a CLM start-up and testing procedure.
Chapter 7. Serial Interface	Describes the multi-format RS-232/422/485 port and the protocol for two way communication between the CLM and a host device.
Chapter 8. Diagnostics & Troubleshooting	Describes the CLM's self-diagnostic system, lists and explains all diagnostic messages and describes troubleshooting procedures.
Appendix A	LA Programming Notes, this section is periodically updated with hints and examples of use for programming commands.
Appendix B	References to other Indramat documentation.
Appendix C	Display Map (CLM control panel display screens)
Appendix D	Listing of each LA command and its format.
Appendix E	Blank parameter record forms (in proper format) for use in documenting your system parameters.
Appendix F	Drawings & schematics of the CLM and its connections.
Appendix G	Installation drawings & details for the CLM and options: CLM keypad (remote mounting), CLM outline/mounting dimensions.
Appendix H	A CLM type code description shows how to interpret the data plate for hardware/software options included.
Registration Form	Complete and return to Indramat to receive revisions to this manual.

1.2 System Features

Superior Performance

The system offers high precision motion control with feed resolution of 0.001 inch. Note that maximum system performance depends on the mechanical characteristics of the user's system.

Easy to Operate

The user simply and easily operates the control system by entering a simple user program using front panel controls or optional interfaces. Operating status messages appear on the display in the user selected language - English, French, German, Spanish or Italian. Other input and display options are described later in this section. The CLM system includes features to make setup quick and easy, eliminating time consuming mechanical setup or complex programming when changing parts.

Parameter-adaptable to Multiple Machines

The machine manufacturer or the user easily adapts the CLM to the mechanical and electrical characteristics of an application by entering data into a set of parameters, using the CLM's 20 digit keypad and liquid crystal display. These parameters define the characteristics of the machine, such as: maximum and minimum feed lengths, jog, acceleration and deceleration rates, units of feed measurement, RS-232/422/485 serial communication characteristics, etc. This allows one single type of CLM control to handle the mechanics of various types of different machines. Thus, plant personnel need be familiar with only one control system.

Generally, parameters are entered once when setting up the system, then changed only if the configuration changes or if different types of operations are required. The factory installed CLM executive program interprets the parameters to match the CLM to the machine, and translates operator-entered commands into motion control signals, coordinating the feed motion with the parts of the other machinery. Complicated system programming is not required.

Fully Self-Diagnostic

System protection is paramount. The CLM detects normal operating status, operator errors, errors in the control itself and machine faults.

Fault and normal status messages are displayed on the CLM control panel in the user selected language. Thus, the operator is informed of the current operating status of the system and alerted to any condition that causes a fault. These messages help the operator quickly locate and correct problems.

The CLM processor models and predicts the motion profile, and continuously compares it with the actual response of the servo drive, thereby detecting irregularities in drive conditions, such as drive runaway or excess position lag conditions. Parameters allow the user to set the magnitude of certain variations, as required for the application, before an error is considered a fault condition.

Programming Structure

The basic program for standard motions is user programmed. The user prepares a program of up to 3000 lines/blocks, utilizing pre-defined commands. These commands, represented by three letter mnemonic codes on the CLM display, specify the function. The CLM display guides the user for proper entry of the necessary data for each command/function utilized, such as axis number, desired position, desired velocity, etc. The CLM can be programmed to run up to three separate task simultaneously (multi-tasking). The CLM can be programmed with several sub-routines. The user can select a different sub-routine from the main program to run different applications. The user can customize the operation of the CLM control for any number of particular applications. The user can download program blocks to the CLM from a host device (computer, PLC, etc.), while the control is in operation.

Programmable Acceleration Rate

The acceleration rate, set by parameter, can be changed (reduced) by programming command. The rate can be changed to different levels for subsequent moves "on the fly" in automatic mode. This is useful for establishing proper rates for new materials or setting required rates for different materials without changing parameter settings.

Knee Point Acceleration

Parameters allow the user to generate a two point (knee-point) acceleration profile, which increases machine life and allows handling difficult, compliant or delicate materials at increased production rates.

Programmable I/O

The Standard CLM includes a set of 24 auxiliary inputs and 19 auxiliary outputs which can be defined by the user for electrically controlling and acknowledging machine functions. The Expanded CLM option increases the auxiliary I/O to 88 inputs and 51 outputs. Additional outputs can be programmed as flags.

The CLM I/O connections are illustrated in Figure 1.5. The additional I/O connections are illustrated as optional, available only with the Extended version CLM.

Control/Machine Synchronization

The CLM has 24 input and 18 output connections which are pre-defined. They include connections to the machine and its control panel for mode selection, cycle start and stop, emergency stop, mode selection acknowledgment, etc. These connections are typically made to keep synchronization between the control and machine. For example, on a slide, the control will not feed if the ram is too close to the material, and/or the external operation will not start until the controlled feed is complete. The axis will not feed if an external operation is pending.

Homing

Homing allows absolute referencing of one or both axes when using an incremental encoder. The user can initiate homing in the manual mode or automatic mode of operation. The CLM offers a great deal of flexibility in customizing the homing routine to compensate for backlash, forward-moving-only applications, homing to a switch, or a variety of other needs.

Registration Control

Registration control maintains each feed as close as possible to a registration mark printed on the material. This ensures that printed patterns are kept in alignment with the finished product.

RS-232/422/485 Serial Interface

A multi-format serial interface allows communication with a programmable logic controller, a Indramat IDS or SOT, a personal computer or other host device. All information normally entered with the keypad and displayed on the LCD (except for registration display) can be communicated at rates of up to 19200 Baud.

Remote Keypad/Display Mounting

The CLM front panel with keypad/display can be mounted separately from the CLM, up to 2 meters away. Thus the CLM can be panel-mounted inside a cabinet, with the CLM's front panel separately mounted on the cabinet surface.

Optional IDS (Thumbwheel Switch Panel with Alphanumeric Display)

An optional thumbwheel switch module (IDS) with alphanumeric display, illustrated in Figure 1.3 is available for the CLM. The IDS connects to the RS-232 connector of the CLM. This unit is remotely mounted, up to twenty (20) meters from the CLM. The operator selects the required feed length and a feed rate on different sets of thumb-wheel switches. The decimal place (resolution) for the feed length is set by parameter. The feed rate is selected as a percentage of the maximum feed rate set by parameter. All status and diagnostic message codes appear on the two digit LED alphanumeric display.

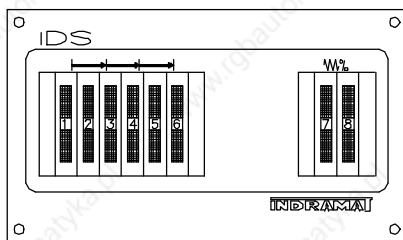

Figure 1-3 Optional IDS

Optional Station Operator Terminal (SOT) and Screen Manager

The Indramat SOT is a remote mounted, operator control device for the CLM (see Figure 1.4). It allows for the same input functions and displays the same information as the CLM control panel, but provides several additional features.

The SOT includes a backlit, liquid crystal display with 16 lines of 40 characters each. It can display much more information at a time than the standard display on the CLM control panel. The software in the SOT provides Help screens to assist the operator in using the SOT and for entering information correctly.

The SOT is programmed using Screen Manager. This command line editor software package runs on a PC computer. Use this program to write information and prompt lines for the operator that will appear on the SOT display. When downloaded to the SOT, these lines cannot be changed from the SOT keypad but data can be entered in response to the prompts.

The SOT keypad includes "click contact" keys for entering/changing data in the CLM, as well as several programmable outputs normally provided on the user's control panel by the machine builder. These may include axis jog - forward/reverse, and cycle start-stop, for example.

The SOT connects to the serial communications port of the CLM and can be mounted up to 1000 meters away. An SOT User's Guide is provided with the option.

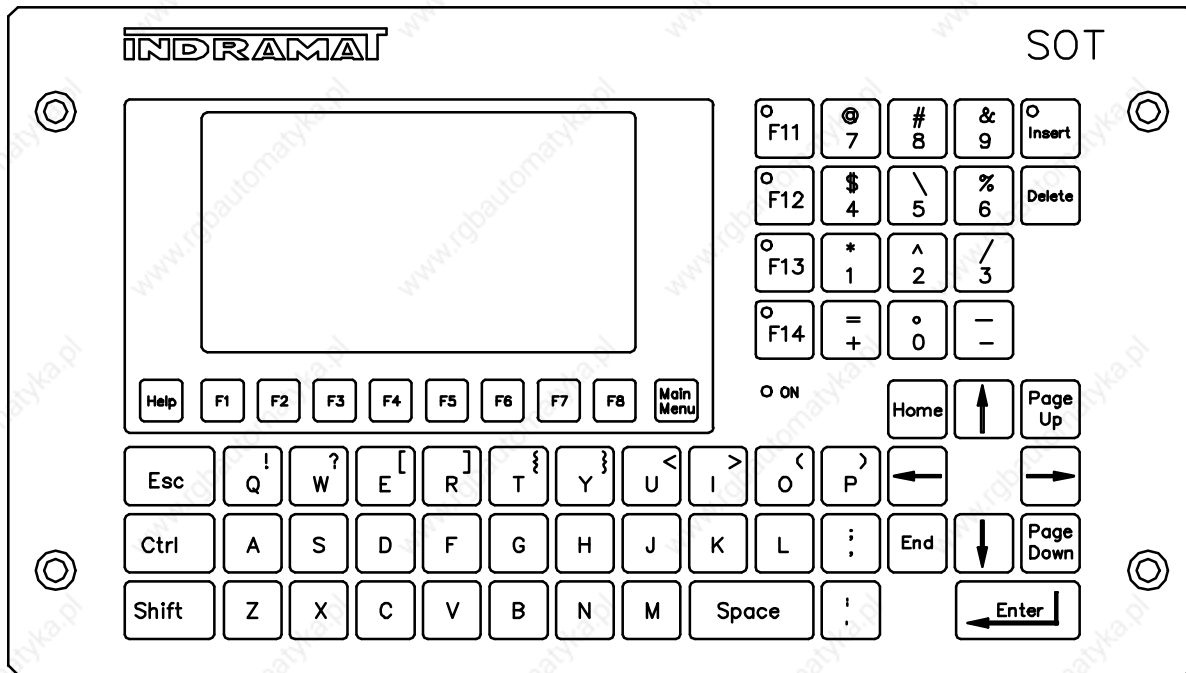

Figure 1-4 SOT - Station Operator Terminal

MotionManager™ (Option)

The MotionManager program assembler is an efficient method of creating and editing executable user programs for the CLM control. This user friendly software package runs on a PC computer. It provides several benefits over programming the CLM from its control panel. It also includes enhanced features for creating and editing programs that are not possible from the CLM control panel.

1.3 Physical Description of the CLM Control

The modular CLM Control mounts to the panel of a control cabinet (electrical enclosure) using two screws. It is designed for mounting side-by-side with the servo amplifiers (one for each axis) and the servo power supply. Installation procedures are described in Chapter 6.

The CLM control panel includes a keypad for entering operating data and a liquid crystal display which shows operating status and diagnostic fault conditions. This keypad / display module can be remotely mounted -- up to 30 meters from the CLM module (i.e. on the user's control panel). The functions and use of the keypad and display are described in detail in Chapter 2.

The CLM includes a set of auxiliary inputs and outputs (I/O) which can be defined by the user for controlling and acknowledging machine functions. The CLM I/O connectors are illustrated in Figure 1.5. The Standard CLM includes 24 auxiliary inputs and 19 auxiliary outputs. The expanded version CLM includes additional connections to expand the I/O to 88 auxiliary inputs and 51 auxiliary outputs. Chapter 3 provides a functional description of each I/O signal connection.

The CLM includes:

- A Motorola 68000 microprocessor.
- 256K of EPROM -- Contains the executive program, exclusively designed for positioning control, eliminating the need for complicated system user programming. It cannot be altered or changed by the user.
- 128K of RAM -- Contains the user-entered parameter data. A lithium backup battery maintains stored memory when power is OFF. The battery is located on the slide out memory card (Figure 2.3).
- 48 inputs and 37 outputs for the Standard CLM/machine interface (the expanded version CLM increases this number of I/O to 88 inputs and 51 outputs).
- 24 inputs and 19 outputs are user definable and programmable (24 inputs and 18 outputs have a pre-defined use for CLM to machine interface).

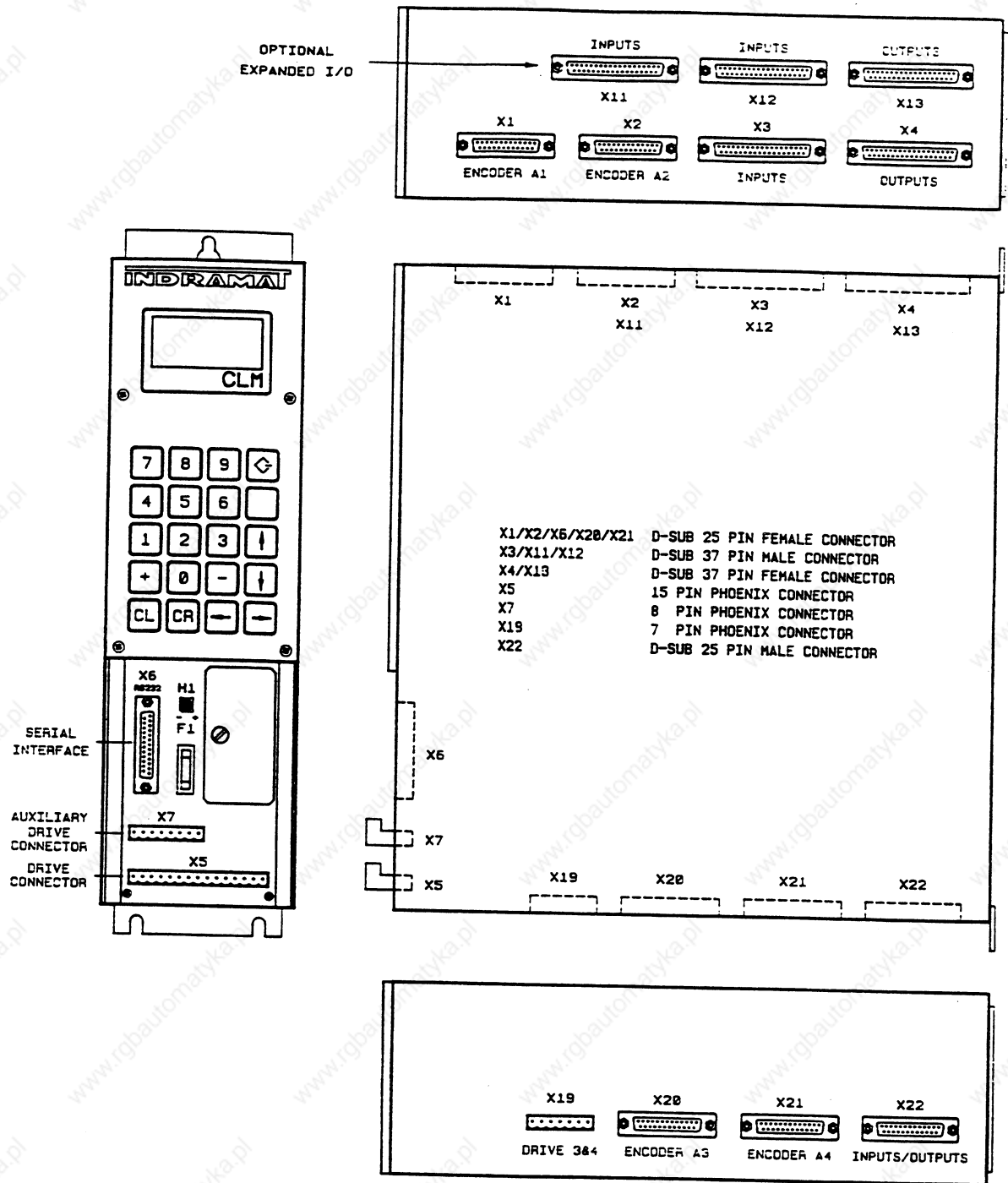

Figure 1-5 CLM Connection Layout

1.4 Brief Operational Description

The CLM, servo amplifier, servo power supply and servomotor are designed into a mechanical system. It, for example, could feed some type of material into another processing station, such as a punch press, thermoforming station, packaging machine, etc.

The machine builder or user enters data into the CLM parameters to specify the mechanical and operating characteristics of the system. Based on this data, plus the feed length and feed rate entered by the operator, the CLM issues positioning commands to the servo amplifier, which controls the current driving the servomotor, which drives the mechanical feed mechanism.

The servomotor includes a tachometer and encoder which provide velocity and position feedback to the control, ensuring precise, repeatable positioning of the material being fed. The final accuracy of the feed system depends on various factors, such as type of material, gearbox backlash and other machine mechanics.

System components are modular, thus installation and replacement of any component of the control system is fast and easy. The CLM module, servo amplifier and servomotor have quick-connect cabling. The servo amplifier and motor are matched for optimum operation using a plug-in "personality" module. Thus, should a failure occur, amplifier replacement is accomplished quickly without the need for electronic fine tuning. This results in a minimum of lost production.

The system is designed to ensure operating integrity and safety, using various inputs and outputs for handshaking to assure that the feeder and subsequent processing station or device operate in harmony. A complete diagnostic system monitors all inputs / outputs and operating conditions and stops the system if a fault is detected. Diagnostic messages are displayed to aid the operator in troubleshooting problems and quickly getting the system back into production.

1.5 Specifications

The following sections provide full specifications for the CLM Control and options.

NOTE: Performance specifications can vary, depending on the mechanical limitations of the equipment.

1.5.1 Physical

Dimensions

Height 15.35 in. (390 mm)

Width 4.13 in. (105 mm)

Depth 12.80 in. (325 mm)

Weight 14 lbs. (6 kg)

Operating Environment

Cooling Convection

Allowable Ambient 41 to 113 deg. F

Temperature Range (5 to 45 deg. C)

Storage and Transport -22 to 185 deg. F

Temperature Range (-30 to 85 deg. C)

Maximum Operating 3,280 ft. (1000 meters)

Altitude at Rated (higher altitudes permitted

Values with proper cooling)

Protection System IP 10 - Open Frame Module suitable for mounting in a control cabinet (e.g., NEMA 12)

1.5.2 Control Specifications

Number of Axes Four (use one, two, three or four)

Position Feedback One Incremental or Absolute Encoder per Axis

Measuring Wheel Feedback Incremental Encoder only

Feed Length Resolution 0.001 inches (0.01 mm)

Feed Rate

Normal -(Operator Selectable) 0.1 - 99.9% of Maximum

Jog - (Parameter Selectable) 0.1 - 99.9% of Maximum

NOTE: Maximum Feed Rate will vary, depending on the mechanical design of the equipment.

Programmable Dwell Time 0.01 - 99.99 seconds in 0.01 steps

Programmable Counters - Limited only by number of program lines

Status/Fault Display LCD, Four (4) line, Alphanumeric, 16 Characters/Line

Entry Keypad 20 membrane switch keys

Power Requirements

Control Voltage, and amperage needed

CLM Control 24 Vdc, 200 mA (per encoder)

Incremental Encoder 24 Vdc, 50 mA (per encoder)

Absolute Encoder 24 Vdc, 400 mA Each

Optional IDS Module - 24 Vdc, 50 mA

Optional Expanded I/O 24 Vdc, 250 mA

NOTE: Add current listed for each item for total system requirements (also see I/O's).

I/O Interface

Inputs 24 (+24 Vdc @ 10 mA)

(pre-defined function)

Auxiliary Inputs 24 - Standard CLM

88 - Expanded Version CLM

(user defined and programmable)

Outputs 18 (+24 Vdc @ up to 50 mA)

(pre-defined function)

Auxiliary Outputs 19 - Standard CLM

51 - Expanded Version CLM (user defined and programmable)

CAUTION: Inputs will have a 10 mA current draw at 24 Vdc. Outputs are thermally protected by a current limiter circuit which eliminates requirement for added fuses. If the load on the output causes a current draw in excess of 50 mA, the output comes on, but then fades. The higher the overload, the faster the fade occurs (within seconds).

Other Interfaces

Parallel cycle interface Used to exchange control, interlock, and status information with a machine control.

Parallel operation interface Used for control signals to / from a local operator station.

Servo interface Provides control of a servo drive with position feedback and for home and over-travel limit switches.

1.5.3 Options

Remote Keypad/Display A cable allows remote mounting of the keypad / display, up to 30 meters from the CLM.

RS-232/422/485 Interface Options This standard interface allows remote operation and other data transfer between the CLM and a optional host device, such as the IDS, SOT, computer or programmable controller

IDS Assembly A remote thumbwheel switch assembly used for entering feed length and feed rate for operation; displays status and fault codes.

SOT Station Operator Terminal- Used for displaying diagnostics, entering feed length, feed rate, etc.

2. CONTROLS AND INDICATORS

This chapter contains a general description of the CLM control layout, plus the following information:

- Description of CLM keypad and display.
- Description of the functions of the keys on the keypad.
- Description of display screens; how to scroll through different screens and how to interpret and change data on the screens.
- Description of the lower front panel.

Figure 1.5 illustrates the CLM front panel, plus top and bottom views of the CLM connectors for the standard and expanded versions. The CLM front panel consists of two sections. The keypad and display module (Figure 2.1) normally attaches to the front of the CLM. The bottom of the front panel includes connectors and other components (Figure 2.3). They are each described in the following sections. The system input/output connections (top and bottom of CLM) are described in Chapter 3. The connections are further described in Chapter 6 for installation.

2.1 Keypad and Display

The CLM keypad / display panel consist of a keypad with 20 pressure-sensitive membrane type keys and a liquid crystal display (LCD) which shows up to four lines of up to 16 alphanumeric characters each. The number of lines and characters showing depends on the selected display mode and the current operating status of the control.

The display informs the operator of the operating status of the CLM system and displays all diagnostic messages. It is also used when entering or editing program or parameters.

The keypad contains all the keys required for data entry, cursor movement, clearing fault/error messages, entering program and parameter data, etc.

The following sections describe the key and display functions.

The keypad and display module are usually attached to the front of the CLM. However, the module can be removed and remotely mounted up to two meters away (with required cable).

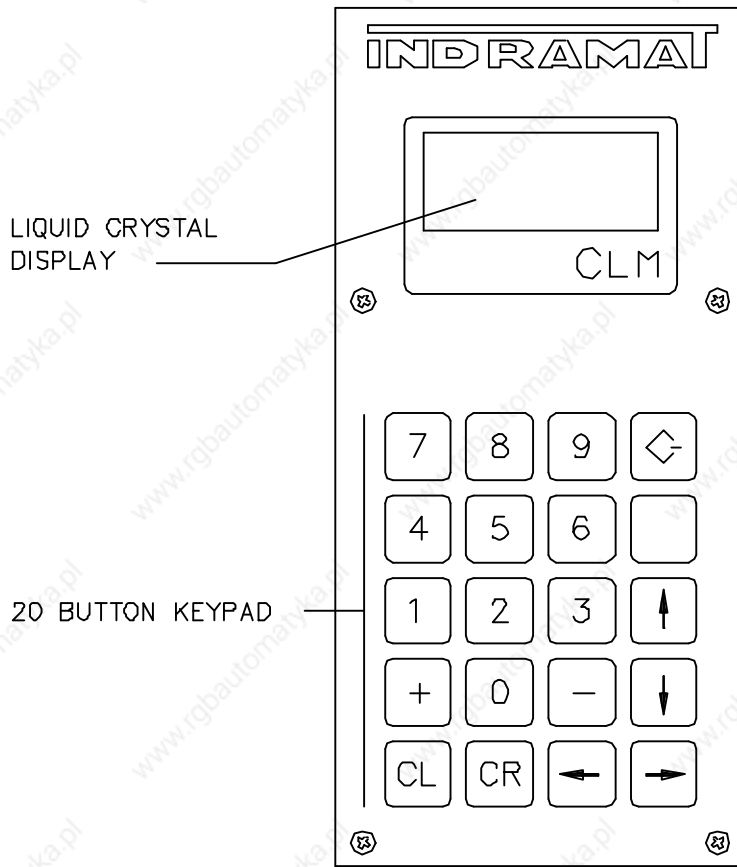



Figure 2-1 Display/Keypad Module

2.2 Data Entry Keys

This section describes the general function of each key on the CLM keypad. Their use is further described throughout the manual for specific functions.

CL	<u>Clear</u> -- Use to clear the a displayed hard or soft fault message, if the fault can be cleared (cause of fault has been corrected). It also clears parameter entry errors. (See Store key for additional uses.)
CR	<u>Carriage Return</u> -- When changing data values, press this key before pressing the Store key to cancel the change and leave the data as previously stored (clear entry). In all display screens which show a flashing cursor (allow editing data fields), use this key to move the cursor to the first position of the data field; press again to move to a previous data field on the display. Continue pressing to move the cursor to home position of the display and allow scrolling to different display screens with the arrow keys.
	<u>Store</u> -- Press to store (save) entered data to the CLM user memory when programming or editing programs or parameters. Pressing the CR key, changing to another block number or other display screen, without first pressing the Store key, cancels data changes and data returns to that previously stored.
+ & -	<u>Plus and Minus</u> -- Use in programming (from Edit screen) to specify the feed direction. When on the Edit screen or Counter Display screen, use these keys to page through the block numbers (the cursor must be on the first line). In parameter mode, use these keys to scroll through the parameter displays.
0 - 9	<u>Numerical Keys</u> -- Use for entering data values.
← →	<u>Left and Right Arrow</u> -- Use to move the cursor to the left or right one position at a time. From certain display screens (ones without a cursor), the right and left arrow keys select additional display screens (see next section).
↓ ↑	<u>Up and Down Arrows</u> -- Use to scroll through display screens (see next section), or parameters (see Chapter 5). Use to scroll through program commands when on the Edit screen. With the cursor positioned next to the command mnemonic (i.e. NOP_), press these keys to step through the program commands in alphabetical order.

NOTE: All displays illustrated in this manual use an underline character (_) to represent the cursor.

2.3 Display Screens

The CLM uses its liquid crystal display for several screens. The operating mode and keyboard selections determine the resulting display.

When the CLM is in Parameter Mode, data for each parameter can be viewed, entered or edited. While in Automatic or Manual Mode, other display screens show the control software version, operation status messages, faults, status of each input and output, counters, etc. The Edit screen allows programming or editing the program data.

The following section describes procedures for scrolling through each of these display screens. Each following section describes the function of each screen, procedures to edit the screens data, etc.

2.3.1 Scrolling Through Display Screens

Refer to the "Display Map" in Figure 2.2 for a full illustration of the display access procedure. For convenience, the same illustration is included in Appendix C. This section describes the basic procedures for reading this "map" and scrolling through the different displays. Each display screen is fully described in the following sections.

To allow easier description, each row of the map is labeled A, B, C, etc. In general, use the up or down arrow keys to change to the "home" display screen of the proceeding or following row. Use the left or right arrow keys to scroll through the displays on each row. All rows allow wrapping from the last screen on the row back to the first screen, and vice versa, by continuing to press the right (or left) arrow key.

NOTE: The CLM display provides four lines with 16 character spaces on each line. However, all display screens do not require all the lines or character spaces. For simplicity, this manual typically illustrates the example displays at the size required for the screen's data.

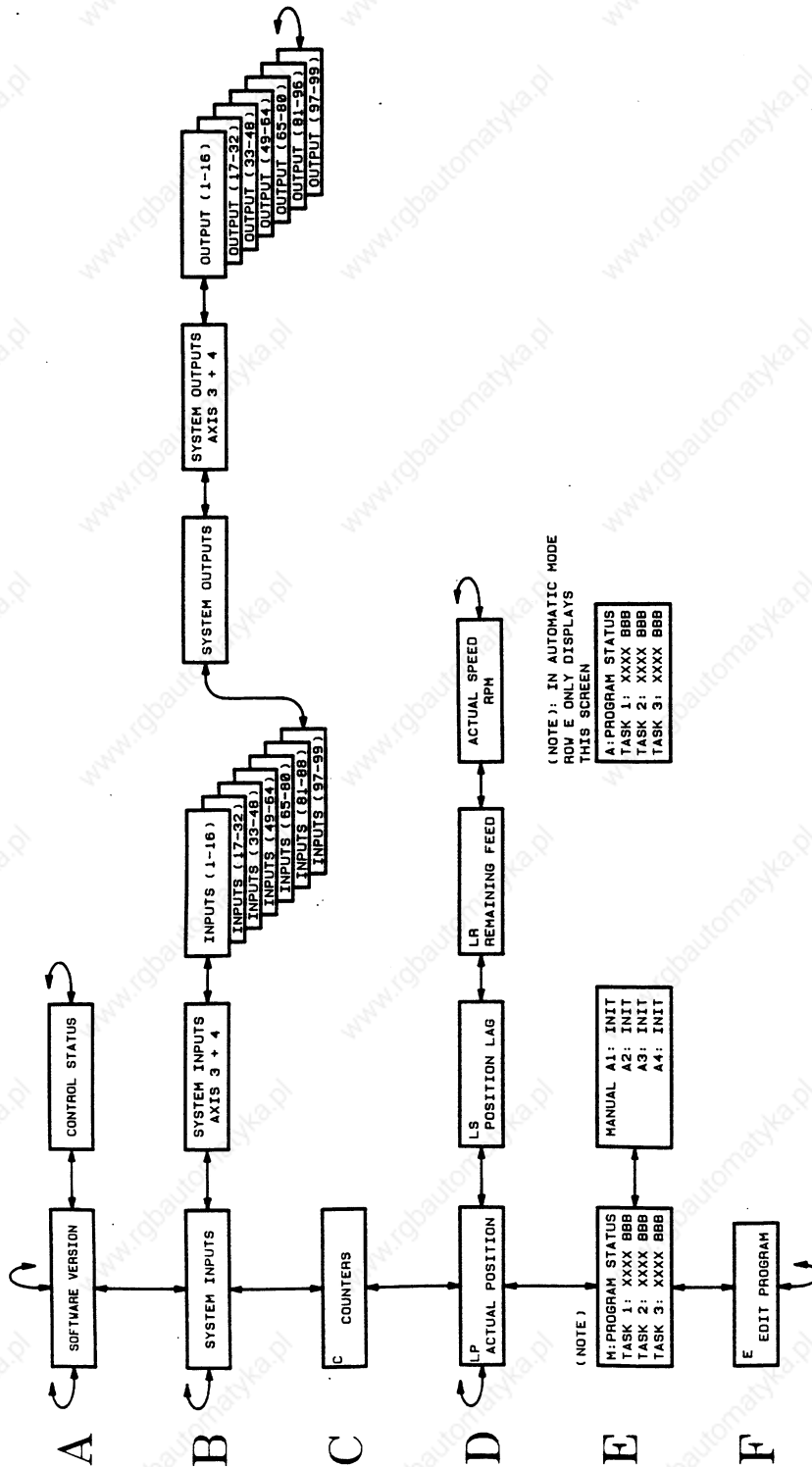

Figure 2-2 Map of CLM Control Panel Display Screens

Row A (Refer to the "Display Map" in Figure 2.2)

With power ON to the CLM and in Automatic or Manual Mode, the display shows the LA software version in the control. Use the right / left arrow keys to toggle between the Software Version screen and the Control Status screen.

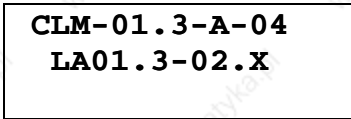

Figure 2-3 Software Display

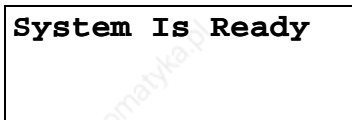

Figure 2-4 Example Status Display

If a fault is present at power ON, a diagnostic status message appears first.

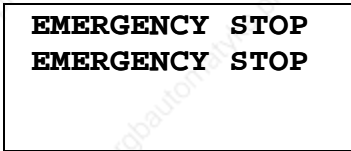

Figure 2-5 Example Fault Display

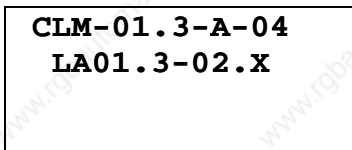

Figure 2-6 Software Display

Row B (Refer to the "Display Map" in Figure 2.2)

Pressing the down arrow key from either display on the top row, changes to the System I/O Displays on Row B. They show the status of each system and auxiliary input and output.

Pressing the right arrow key from the first System Inputs screen causes the display of specific System Inputs for axes 3 and 4. Pressing the right arrow key from this screen causes the display of the Auxiliary Inputs, 16 at a time (i.e. 1-16, 17-32, etc., up to input 99). Continue pressing the right arrow key to see System Outputs, then the axes 3 and 4 specific System Outputs, then the Auxiliary Outputs, 16 at a time (i.e. 1-16, 17-32, etc., up to output 99). Continue pressing the right arrow key to scroll past the end of the line back to System Inputs. Use the left and right arrow keys to scroll through screens on the same line.

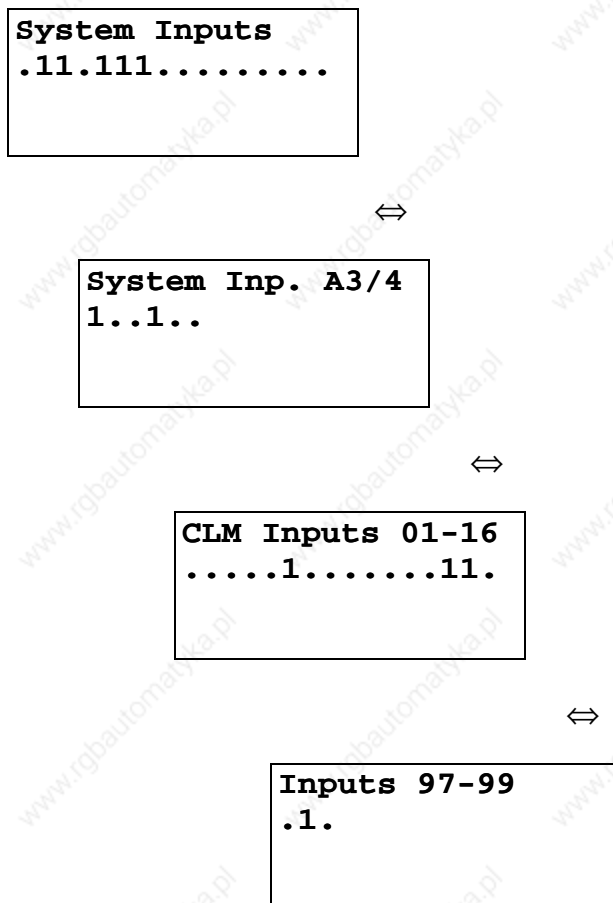

Figure 2-7 System I/O Display Screens

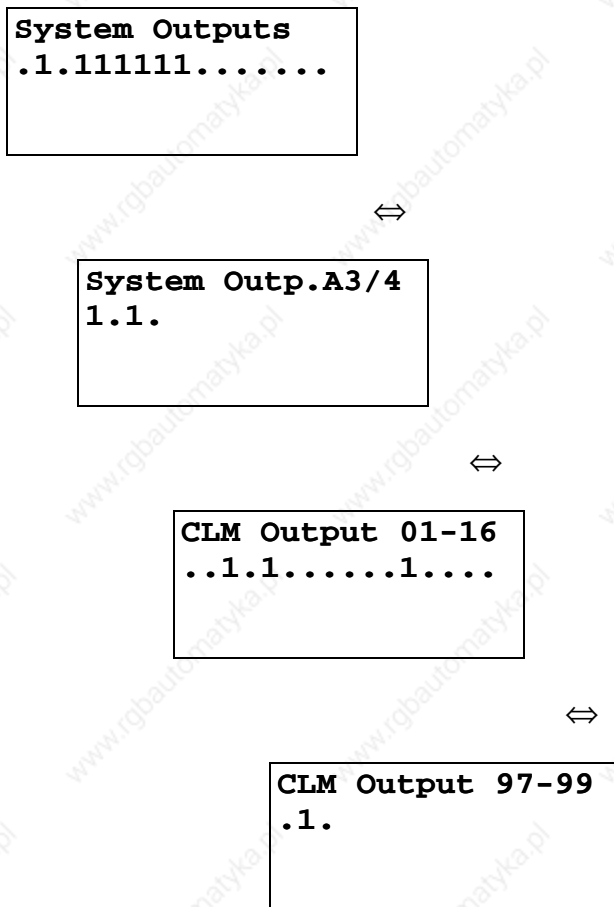

Figure 2-8 System I/O Display Screens (cont'd)

Row C (Refer to the "Display Map" in Figure 2.2)

Pressing the down arrow key from any display in the B row, changes to the Counter Display on Row C. It show the status of the counter now executing or in the selected block number.

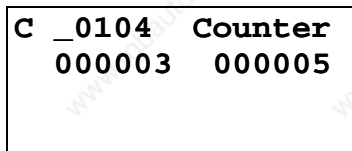

Figure 2-9 Counter Display

Row D (Refer to the "Display Map" in Figure 2.2)

Pressing the down arrow key from the display in Row C, changes to the Current Position Display in Row D.

Pressing the right arrow key causes display of the Position Lag screen. Continue pressing the right arrow key to display the Remaining Feed and Actual Speed RPM display screens. The "L" in the top row of the display indicates Axes Position Display mode. The "S", "P", or "R" after the "L" indicates the Lag (S), the Current Position (P) or Remaining Feed (R) display screen respectively.

L P 1	+00000.000
2	+00000.000
3	+00000.000
4	+00000.000

Figure 2-10 Current Position Display

↔

L S 1	+00000.000
2	+00000.000
3	+00000.000
4	+00000.000

Figure 2-11 Position Lag Display

↔

L R 1	+00000.000
2	+00000.000
3	+00000.000
4	+00000.000

Figure 2-12 Remaining Feed Display

↔

Act.	Speed RPM
1: 0000	2: 0000
3: 0000	4: 0000

Figure 2-13 Actual Speed Display

Row E (Refer to the "Display Map" in Figure 2.2)

Press the down arrow key from any display in Row D to see the CLM Mode/Tasks Displays. If the CLM is in Manual Mode, a "M" appears on the screen, along with the status of Task 1, 2 and 3. Use the left / right arrow keys to toggle between this screen and the Axis Enabled screen.

```
M:Program Status
Task 1:0091 BCE
Task 2:0366 VCC
Task 3:0901 BCE
```

Figure 2-14 Manual Mode Task Display



```
Manual A1 Init.
        A2 Init.
        A3 Init.
        A4 Init.
```

Figure 2-15 Axis Enabled Display

When the CLM is in Automatic Mode, only the task display is available on this row. An "A" appears on the screen (Automatic Mode), along with the status of Task 1, 2 and 3.

```
A:Program Status
Task 1:0091 BCE
Task 2:0366 VCC
Task 3:0901 BCE
```

Figure 2-16 Automatic Mode Task Display

Row F (Refer to the "Display Map" in Figure 2.2)

From any screen in Row E, press the down arrow key to display the Program Edit screen in Row F. Notice the "E" in the upper left corner of the screen easily identifies it as the Edit display screen.

```
E _0096 BCE
0200 02 1
```

Figure 2-17 Edit Display

NOTE: From Row F, press the down arrow key to wrap to a display screen in Row A. From Row A, press the up arrow key to display the Edit screen in Row F.

2.3.2 Parameter Mode Display Screens

When the CLM is in Parameter Mode, data for each parameter can be viewed, entered or edited.

The top line of the display indicates the title of the parameter number and the axis number (1 through 4). The following display shows Parameter A100 - Maximum Velocity for Axis 1.

Max Velocity A1
A100 <u>0</u>0001000

A100 - indicates parameter number

"A" indicates axis data parameter set; "1" indicates axis # 1; "00" indicates parameter number 00001000 - indicates data for parameter

When Parameter Mode is selected, the parameter display appears with the cursor on the first digit of the parameter data field. Use the right / left arrow keys to move the cursor in the field. Type over existing data to change and press the Store key to save the change. When first entering parameter data, an asterisk (*) appears in the specific digit positions of the data field where an entry must be made. Appendix E provides blank parameter entry forms which show the required entry positions. Always maintain an accurate listing of your parameter entries for reference when troubleshooting or changing parameters for a different application.

To select other parameters to display, first move the cursor onto the parameter number by pressing the CR key. If the cursor is within the data field, pressing CR once will cause it to move to the beginning of that field. Press it again to move the cursor to the beginning of the previous field. The left and right arrow keys will also move the cursor within and between fields.

To change from one axis parameter set to another, move the cursor to the first position after "A" (or "B") and enter 1, 2, 3, or 4 to view/edit the appropriate axis parameter set; enter 0 to change to the "B" parameter set (system parameters).

With the cursor on the parameter number, type over to enter the parameter number desired to display. Pressing the arrow keys will also cause the parameter display to change to the next higher (up arrow) or lower (down arrow) parameter number within the axis parameter set. Refer to Chapter 4 for specific parameter entry options and requirements.

2.3.3 Software Version / Control Status / Fault Display Screens

With the Drive Ready switches ON (external connections) for each axis enabled (1, up to 4) turn ON power to the CLM Control. In Automatic or Manual Mode, the display shows the CLM hardware version and the LA software version in the control.

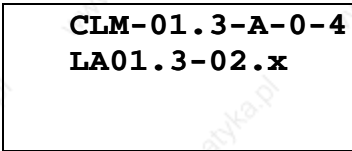
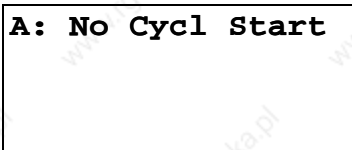

Figure 2-18 Software Display

CLM-01.3-A-0-4 - indicates hardware type

LA01.3-02.x - indicates software number (x=minor revision number)

Use the right / left arrow keys to toggle between the Software Version screen and the Control Status screen. This screen shows the status of the control. In the example below, Automatic Mode is selected (A:), but Cycle Start has not been pressed to start automatic operation.



If a hard or soft fault occurs, control function stops and a diagnostic message appears on the display. If a fault is present at power ON, a diagnostic status message appears first (instead of the software version). It is in the status display screen. Pressing the right arrow key will cause the software version to display. See Chapter 8 for diagnostic messages and troubleshooting procedures.

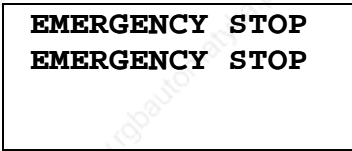

Figure 2-19 Example Fault Status Display

2.3.4 System I/O Display Screens

System I/O Display screens show the status of each system and auxiliary input and output. The status of a block of 16 inputs or outputs display on a screen at a time. These displays are helpful to verify wiring during start-up or troubleshooting. They also provide a quick summary of system status during normal operation.

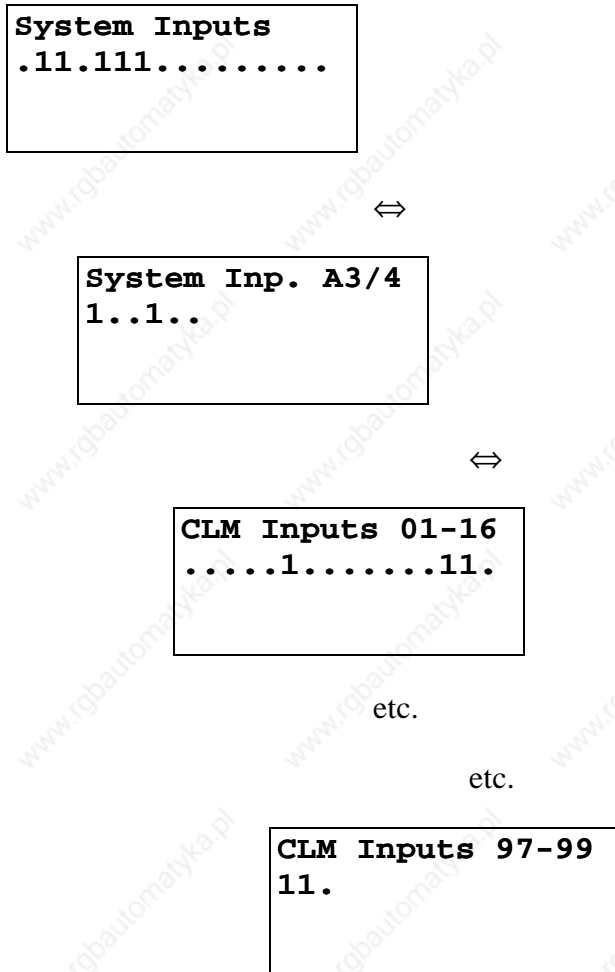

Figure 2-20 System I/O Display Screens

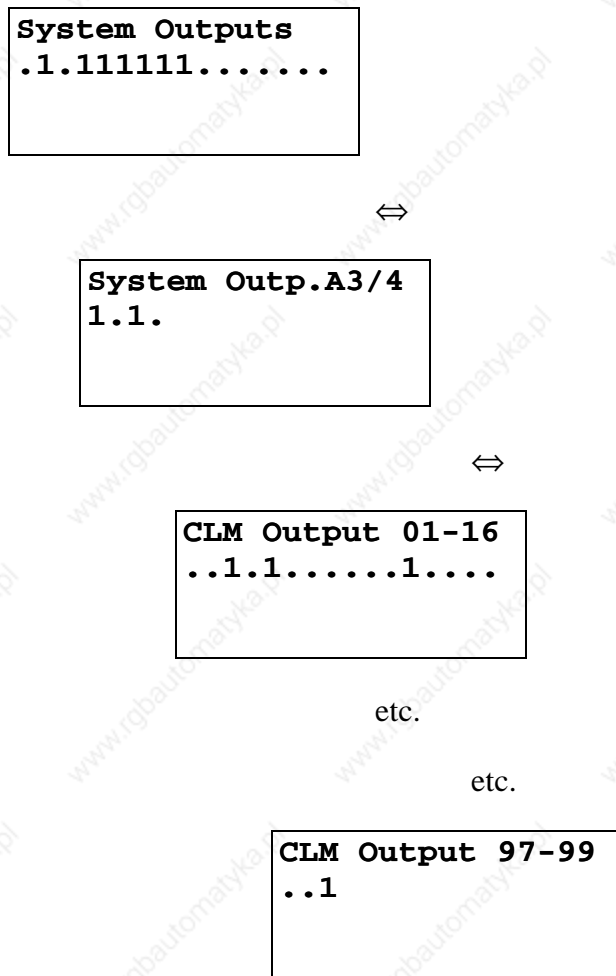

Figure 2-21 System I/O Display Screens (cont'd.)

The status of each of the 16 input or output signal lines on a screen are represented by a character in the bottom row of the display. A Low signal (0 volts) is represented by a decimal (.). A High signal (+24 volts) is indicated by a one (1). The signal lines count from left to right on the display (1-16, 17-32, etc.).

24 System Inputs and 18 System Outputs have a fixed or pre-defined function for the CLM. The first 16 lines of connector X3 (input) and X4 (output) are dedicated for functions like mode selection and acknowledgment, cycle start, jog forward/reverse for axis 1 and 2, etc. The first 8 lines of connector X22 are dedicated for functions like jog forward/reverse, drive ready, etc. for axis 3 and 4. Chapter 3 provides a functional description for each of these I/O connections. Table 2.1 (following this section) provides a legend of the I/O signal function for each I/O display screen, and the corresponding connector for hardware I/O connections.

Auxiliary I/O connections are user definable and programmable. The numbers "1-16" in the top row of the display indicates the 16 lines designated auxiliary of connector X3 (input) or X4 (output), that are being monitored on the Standard CLM. The Expanded CLM provides additional I/O hardware connections. With either the Standard or Expanded CLM, these output points above the auxiliary connections (hardware), can be programmed as software flags. Certain output flags are set in firmware and can be queried by the user program. Chapter 5 defines the restrictions and use of these auxiliary outputs as software flags.

Table 2-1 I/O Signal Display Legend

Display/Position	Signal Description	Connector pin #
System Inputs		
1	Parameter Mode Select	X3- 1
2	Automatic Mode Select	2
3	Emergency Stop	3
4	Cycle Start	4
5	Cycle Stop	5
6	Axis #1 Drive (Amp) Ready	6
7	Axis #2 Drive (Amp) Ready	7
8	Clear	8
9	Axis #1 Jog Forward	9
10	Axis #1 Jog Reverse	10
11	Axis #2 Jog Forward	11
12	Axis #2 Jog Reverse	12
13	<i>not currently defined</i>	13
14	<i>not currently defined</i>	14
15	Execute Restart Vector	15
16	High Speed Interrupt	16
System Inputs, A3/A4		
1	Axis #3 Drive (Amp) Ready	X22-1
2	Axis #3 Jog Forward	2
3	Axis #3 Jog Reverse	3
4	Axis #4 Drive (Amp) Ready	4
5	Axis #4 Jog Forward	5
6	Axis #4 Jog Reverse	6
Auxiliary Inputs 01-16		
01	<i>user defined</i>	X3-17
through		through
16	<i>user defined</i>	32

Display/Position	Signal Description	Connector pin #
Auxiliary Inputs 17-32 (Use requires Expanded I/O option)		
17	user defined	X11-1
through		through
32	user defined	16
Auxiliary Inputs 33-48 (Use requires Expanded I/O option)		
33	user defined	X11-17
through		through
48	user defined	32
Auxiliary Inputs 49-64 (Use requires Expanded I/O option)		
49	user defined	X12-1
through		through
64	user defined	16
Auxiliary Inputs 65-80 (Use requires Expanded I/O option)		
65	user defined	X12-17
through		through
80	user defined	32
Auxiliary Inputs 81-88		
81	user defined	X22-9
through		through
88	user defined	16
Auxiliary Inputs 98 & 99 (System Defined Use)		
98	High Speed Input (future use)	X22-7
99	High Speed Input (future use)	8
System Outputs		
1	Manual Mode Indicator	X4-1
2	Automatic Mode Indicator	2
3	Parameter Mode Indicator	3
4	Axis #1 Drive (RF) Enable	4
5	Axis #1 Brake Release	5
6	Error! Reference source not found. Indicator	6
7	Axis #2 Drive (RF) Enable	7
8	Axis #2 Brake Release	8
9	Restart Possible	9
10	Auto Cycle Running	10
11 - 14	not currently defined	11-14

Display/Position	Signal Description	Connector pin #
15	Axis #3 Drive (RF) Enable	15
16	Axis #4 Drive (RF) Enable	16
System Outputs, A3/A4		
1	Axis #3 Drive (RF) Ready	X19-6
2	Axis #3 Brake Release	X22-17
3	Axis #4 Drive (RF) Ready	X19-7
4	Axis #4 Brake Release	X22-18
Auxiliary Output 01-16		
01	user defined	X4-17
through		through
16	user defined	32
Auxiliary Output 17-32 (Requires Expanded I/O option, see Table 5.1 in Chapter 5 for restrictions and use as software flags)		
17	user defined	X13-1
through		through
32	user defined	16
Auxiliary Output 33-48 (Requires Expanded I/O option, see Table 5.1 in Chapter 5)		
33	user defined	X13-17
through		through
48	user defined	32
Auxiliary Output 49-64 (See Table 5.1 in Chapter 5 for use as software flag)		
49, 50, 51	user defined	X22-19 through 21
52 - 64	user defined as software flag	
Auxiliary Output 65-80 (See Table 5.1 in Chapter 5 for use as software flags)		
65	user defined as software flag	
through		
80	user defined as software flag	
Auxiliary Output 81-88 (See Table 5.1 for use as software flags)		
81	user defined as software flag	
through		
88	user defined as software flag	
Auxiliary Output 89-99 (See Table 5.1 for specific use and warnings)		
89 - 94	function set in firmware as follows:	
89	1 indicates Manual Mode	

Display/Position	Signal Description	Connector pin #
90	1 indicates Automatic Mode	
91	not currently defined/used	
92	not currently defined/used	
93	not currently defined/used	
94	0 indicates a system Fault	
95-99	function set in user program to provide specific function, as follows:	
95	Monitoring Window, Axis 1 turned: OFF=1, ON=0	
96	Monitoring Window, Axis 2 turned: OFF=1, ON=0	
97	not currently defined/used	
98	1=Axis 1 motion is interrupted	
99	1=Axis 2 motion is interrupted	

2.3.5 Counter Display Screen

The Counter display screen shows the status of the counter now executing in the selected block number. Any counter programmed in blocks 0000-2999 can be monitored using this display mode.

C	_0123	Counter
	123456	456789

Table 2-2 Counter Display:

C	indicates counter display
0123	indicates block number of counter
123456	actual number of counts
456789	preset number of counts

Use the right arrow to move the cursor on the first digit of the block number. Enter a number for another block to select that block number counter information to display. The second line displays the current values of the counter. To scroll to the next or previous block with a counter, use the + , - keys. To leave the counter display mode, use the up or down arrow keys.

A counter can be programmed (see Chapter 5, BAC or COU command) to execute "X" number of parts then stop, and turn ON a light, etc. Count is maintained during shut-down, so the actual manufacturing process can be over several days. Counters can also be used to keep track of production.

NOTE: The actual count will be maintained by battery backup, even when power is turned OFF.

2.3.6 Axis Position Display Screen

Pressing the right arrow key from the Current Position screen causes display of the Position Lag screen. Continue pressing the right arrow key to display the Remaining Feed and Actual Speed RPM display screens. The "L" in the top row of the display indicates Axes Position Display mode. The "S" , "P" , or "R" after the "L" indicates the Lag (S), the Current Position (P) or Remaining Feed (R) display screen respectively.

The values on these screens keep changing as they display the actual current information for each axis. Each display screen is further described below. See following section 2.3.6.5 for changes in displays when the Measuring Wheel option is enabled.

2.3.6.1 Current Axis Position Display Screen

L P 1A+00000.000
2A+00000.000
3A+00000.000
4A+00000.000

Table 2-3 Current Position Display

L	indicates axis position display mode
P	indicates axis current position screen
1A, 2A, 3A, 4A	designation of axis (the 'A' will only appear after the axis has been homed)
+00100.000	indicates direction of travel (+/-) and actual position of indicated axis (1, 2, 3 or 4) in Input Units

The position values displayed can be cleared by pressing the CR key (if the axis has not been homed).

2.3.6.2 Axis Position Lag Display Screen

L S 1A+00000.000
2A+00000.000
3A+00000.000
4A+00000.000

Table 2-4 Position Lag Display

L	indicates axis position display mode
S	indicates axis position deviation screen
1A, 2A, 3A, 4A	designation of axis (the 'A' will only appear after the axis has been homed)
+00000.000	deviation between commanded position and actual axis position in Input Units.

When an axis is in motion, the value displayed here is also known as "following error". This value is directly proportional to the velocity command output to the amplifier. The higher the speed, the higher the following error. This value is zero only when the drive is in position. An excess following error (limits set by parameter) due to binds in the system, etc. will cause a fault condition.

2.3.6.3 Axis Remaining Feed Display Screen

L R 1A+00000.000
2A+00000.000
3A+00000.000
4A+00000.000

Table 2-5 Remaining Feed Display

L	indicates axis position display mode
R	indicates axis remaining feed screen
1A, 2A, 3A, 4A	designation of axis (the 'A' will only appear after the axis has been homed)
+00000.000	difference between the commanded feed length and current actual axis position in Input Units.

The value displayed here is the feed length remaining before the axis reaches the commanded feed length target position (including any programmed alteration [+/-] to the normal feed distance).

2.3.6.4 Actual Speed/RPM Display Screen

Act. Speed RPM
1: 0000 2: 0000
3: 0000 4: 0000

Table 2-6 Actual Speed Display

+0000.00 - Direction (+/-) and actual speed (RPM) of the axis.
--

The actual speed displays for each axis. The second line of the display shows information for axis 1, then axis 2. The third line shows information for axis 3, then axis 4.

2.3.6.5 LP/LS Display Screens with Measuring Wheel

When the Measuring Wheel option is selected, only axis 1 and 2 may be enabled. The Actual Position and Position Lag screen are expanded beyond the normal 2-axis display, as illustrated below.

L P 1A+00059.990
2 +00012.690

P 1 +00059.870

Table 2-7 Current Position Display

line 1	position axis 1 (all MW movements are used)
--------	---

line 4	position motor encoder 1
--------	--------------------------

L S 1A+00059.990
2 +00000.210

D 1 +00000.120

Table 2-8 Position Lag Display

line 1	position error axis 1
line 4	position difference between axis 1 and motor encoder 1

2.3.7 Mode/Tasks Display Screens

If the CLM is in Automatic Mode, an "A" appears on the screen, along with the status of Task 1, 2 and 3. If the CLM is in Manual Mode, two screens are available. On the first screen, a "M" appears on the screen, along with the status of Task 1, 2 and 3. Use the left / right arrow keys to toggle between this screen and the Axis Enabled screen. Each display screen is further described below.

2.3.7.1 Task Display - Manual Mode

M:Program Status
Task 1: 0091 BCE
Task 2: 0366 VCC
Task 3: 0901 BCE

Figure 2-22 Manual Mode Task Display

This display shows the current block number (091) and related command mnemonic (BCE) for each task. Task 3 runs when the CLM is in manual or automatic mode. The information keeps changing as each block of program executes. Tasks 1 and 2 start running at the block number set in parameter B006, only in automatic mode. In manual mode, the display shows information for tasks 1 and 2 for the program block that was executing or next to execute during automatic mode cycling (or starting block).

2.3.7.2 Axis Enabled Display - Manual Mode

Manual	A1 Init.
	A2
	A3 Init
	A4 Init

Table 2-9 Axis Enabled Display

A1, A2, A3, A4	the indicated axis number amplifier is "ready" to operate
----------------	---

Init.	indicates axis has been homed (in this example display, axis 2 has not been homed)
-------	--

2.3.7.3 Task Display - Automatic

A:Program Status
Task 1: 0091 BCE
Task 2: 0366 VCC
Task 3: 0901 BCE

Figure 2-23 Automatic Mode Task Display

This display shows the current block number, 0091 for Task 1, and related command mnemonic (BCE) for each task. Task 3 runs when the CLM is in manual or automatic mode. Tasks 1 and 2 start running at the block number set in parameter B006, only in automatic mode.

During automatic operation (after Cycle Start), the information keeps changing as each block of program executes. If **Error! Reference source not found.** signal goes low (switch is pressed), the drive immediately stops and the display shows information for the program block that was executing or just about to execute.

2.3.8 Edit Mode Display Screen

Use the Program Edit screen to enter the complete executable program. Also use this screen to edit or review an existing program.

E _0096 BCE
0200 02 1

Table 2-10 Edit Display

E	indicates edit display mode
0096	block number, 0000-2999 is user selectable for edit and review; automatically increments to next higher number during programming
BCE	command mnemonic
0200 02 1	data for the block command

When first scrolling to this screen, a flashing cursor appears in the home position (third position from left in the first line). As with other display screens which include a cursor, press the left or right arrow keys to move the cursor within the screen. Also, press the CR key to move the cursor to the first digit position of a data field. Press CR again to move the cursor to the first position of the previous field. Continue pressing the CR key until the cursor is in home position or over the left digit of the block number, before using the up/down arrow keys to scroll to different display screens.

To select different program blocks of information to display (for review or edit), press the right/left arrow keys to position the cursor over the first digit of the block number and type over the existing block number. Command and data for this selected block will then appear. To scroll through the block numbers, press the CR key to locate the cursor in the top line, then use the + or - key to scroll through the blocks (with previous version software, the cursor must be to the left of the block number - home position). The block number will increase or decrease accordingly and display the respective data for each block.

To enter program, start at block "0000" for task 1. Note that task 2 and task 3 program starts at the block number assigned by the user in parameter B006. If block "0000" is not displayed, press the right arrow key one time from home position to move the cursor on the first digit of the block number. Type the number "0000" to display that block number.

To enter or change a program command for each block, first press the right arrow key until the cursor moves to the right of the three digit program command mnemonic (i.e. NOP_). Press the up or down arrow keys to increment or decrement through the commands alphabetically. When the desired command appears on the screen, press the right arrow key. The cursor moves to the beginning of the second line where the data fields appear specifically for the selected command. If this block was not previously programmed with this same command, asterisks (*) appear in the digit positions where data must be entered. After entering and verifying the program, press the Store key to save the programmed block to memory. The next program block number automatically appears, waiting to be programmed. Continue this process until all lines of user program are done. Note that the program can be edited or added to at a later time.

When changing data from the Edit display screen, pressing the CR key before pressing the Store key, will cancel the change and leave the data as previously stored (saved). The display remains at the same block number and the cursor moves to the first position of the previous field. Changing to another block number, display screen, etc. without first pressing the Store key also causes loss of a change to a block's data.

Chapter 5 provides the information on commands required for creating the user executable program.

2.4 Lower Front Panel

There are six items located on the lower part of the front panel (refer to Figure 2.3). They are:

- The CLM Ready Indicator (labeled H1) is a green LED which indicates the "amplifier ready" contact (labeled Bb on the X5 Command Connector) is closed and the CLM is ready to operate.
- The X6 RS-232/422/485 Communications Port is located in the upper left corner below the keypad. This 25 pin, sub-miniature D connector allows communication between the CLM and a IDS, SOT, PLC or other host.
- The 1.6 Amp Fuse, labeled F1, protects the CLM from a current surge.
- The X5 Drive Command Connector is located at the bottom of the lower panel. These terminals connect to the power supply, and the analog command outputs for Axis 1 and 2. It also has inputs for analog override of Axis 1 and 2.
- The X19 connector (located on the bottom side of the CLM - see Figure 1.5), functions similar to the X5 connector, but commands axes 3 and 4.
- The Memory and Battery Module (MOK) is a slide out card containing the lithium battery plus RAM and EPROM memory. A low battery charge will be indicated on the display.
- The X7 RF Connector is located between the X6 and X5 connectors. This terminal is currently used to connect RF1, Axis 1, and RF2, Axis 2, Amplifier Enable Outputs, to the RF terminal of the servo amplifiers. It also has inputs and a +10v output for analog override of Axis 3 and 4.

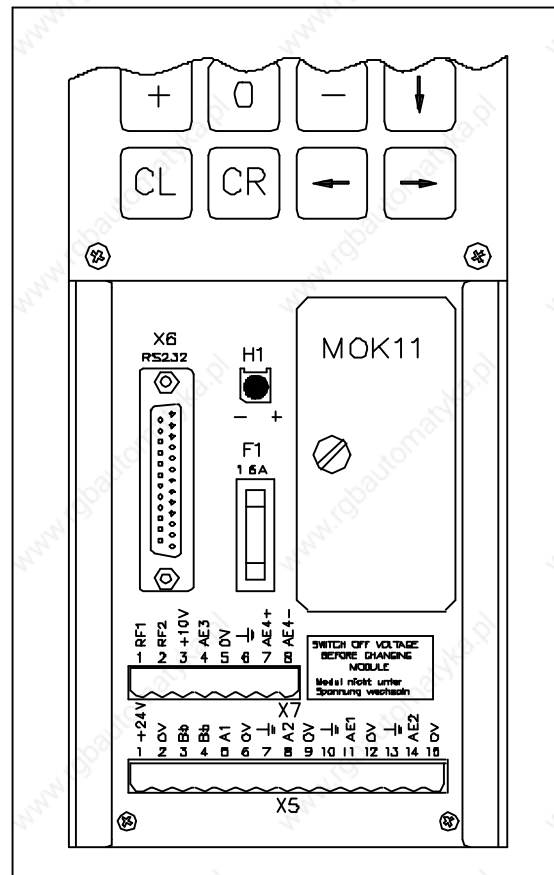

Figure 2-24 CLM Lower Front Panel

3. FUNCTIONAL DESCRIPTION OF I/O CONNECTIONS

The CLM motion control system is designed to function harmoniously within the machine builder's equipment design. Several input / output signals of the CLM control provide communication to / from the other components of the machine builder's equipment. This chapter describes the functional operation of the interfacing inputs and outputs of the CLM.

The first sections of this chapter describe the various interface functions in terms of the inputs / outputs involved with each. This includes the pre-defined I/O connections of the CLM, as well as certain functions which the user can select through parameter or programming, using auxiliary I/O connections. Certain auxiliary output functions are set in firmware, as described in Chapter 5 for user programming.

This first section is followed by an individual description of each pre-defined I/O signal, including name, pin assignments, and functional description. The designer utilizes these signals as necessary to implement the CLM for his application, including the design of his system control panel.

3.1 Signal Definitions

The states of the input and output signals described in this manual are:

- High = +24 Vdc
- Low = 0 Vdc

A signal line is described as "active high" when its associated action is initiated by a high (+24 Vdc) signal level. It is described as "active low" when its function is initiated by a low signal (0 volts). Active low signals are shown in this manual (when specifically referred to as a signal) with a bar (line) over the signal name, as an example, $\overline{\text{Emergency Stop}}$. This signal must be high during normal operation. If it goes low, the CLM initiates the actions required for an emergency stop function.

3.2 Interface Descriptions

The CLM input and output signals provide communication to/from the machine builder's equipment. Certain I/O signals should be considered as functional groups of signals, working in concert.

These functions include:

- Operating Mode Selection
- Servo System Operation Enables
- Safety Interlocks
- Normal Operation Signals
- Axis Homing
- Manual Operations
- Fault/Diagnostic Circuitry
- Feed Monitoring / Program Interruption
- Special Functions

Figures 3.1, 3.2 and 3.3 illustrate the X3 Input, X4 Output and X22 Input/Output connectors and each pin designation.

The following sections describe each group of interface functions, first listing the I/O signals involved (and section where each signal is individually described), then describing the general function of the signals.

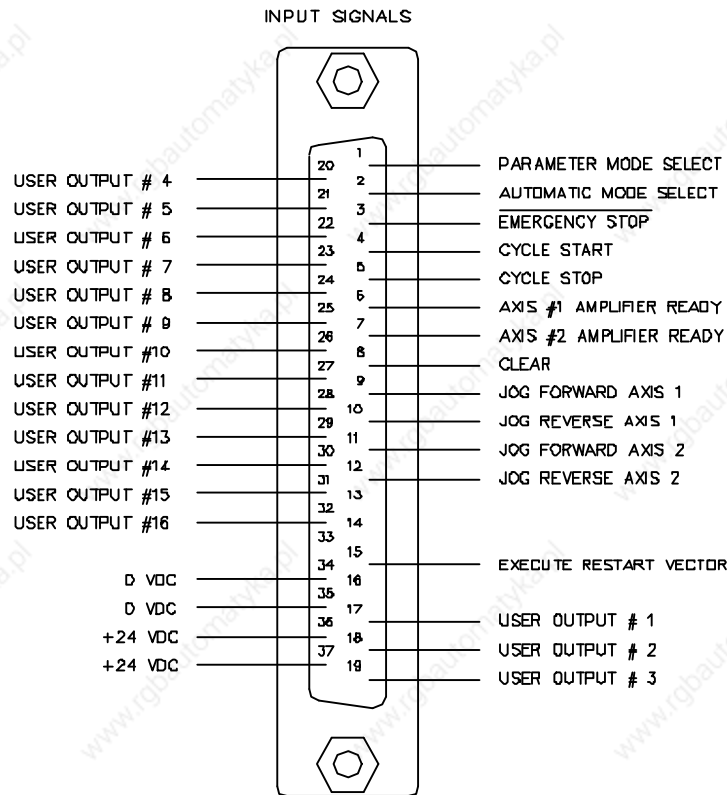

Figure 3-1 X3 Input Connector and Pin Designations

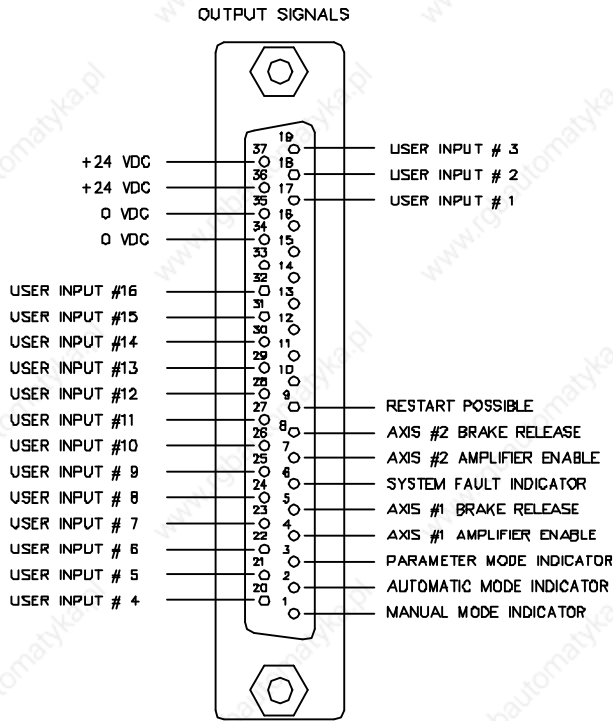

Figure 3-2 X4 Output Connector and Pin Designations

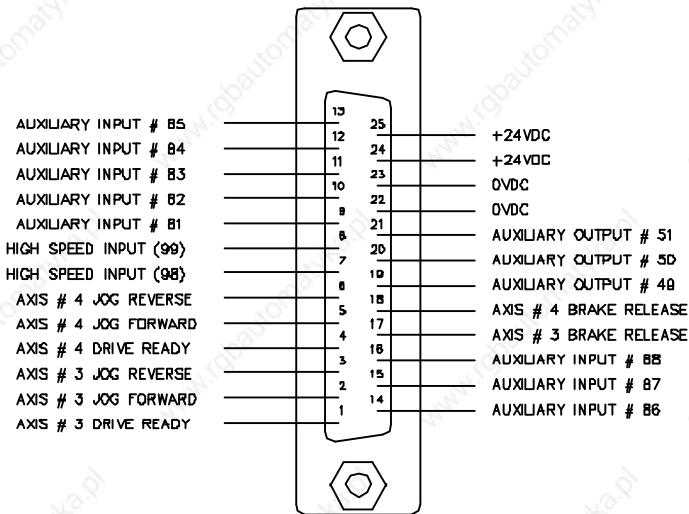

Figure 3-3 X22 Input/Output Connector and Pin Designations

3.2.1 Operating Mode Selection

Inputs

Parameter Mode Select	(3.3.1)
Automatic Mode Select	(3.3.2)

Outputs

Manual Mode Indicator	(3.4.1)
Auto Mode Indicator	(3.4.2)
Parameter Mode Indicator	(3.4.3)

The CLM will always be in one of three operating modes:

Parameter Mode	Allows entry/verification of the parameters required to adapt the control for the specific requirements of the application.
Automatic Mode	Runs the user written executable program for automatic cycle operation (process 1 and 2 run after a Cycle Start input).
Manual Mode	Default mode when neither of the above are selected. In this mode, use the jog inputs to move the material forward or reverse through the system.

Parameter and Automatic Modes are selected by bringing the appropriate signal line high (+24 Vdc). A fault is diagnosed and an "Invalid Mode Selection" error message is issued if both Automatic and Parameter Mode signal lines are high simultaneously.

The suggested interface design is to wire the Parameter Mode signal to a key-switch, where a key is required to enter Parameter Mode and/or mount the switch inside the cabinet. This helps to prevent unauthorized parameter changes. Wire the Automatic Mode input signal to a two-position selector switch, where Manual Mode is selected when the switch is set to an open contact position.

The CLM has outputs to verify or acknowledge the currently selected mode. These are typically wired to indicator lights on the user's control panel or to a PLC.

3.2.2 Servo System Operation Enables

Inputs

Axis 1 Amplifier Ready	(3.3.6)
Axis 2 Amplifier Ready	(3.3.6)
Axis 3 Amplifier Ready	(3.3.6)
Axis 4 Amplifier Ready	(3.3.6)

Outputs

Axis 1 Amplifier Enable	(3.4.4)
Axis 1 Brake Release	(3.4.5)
Axis 2 Amplifier Enable	(3.4.4)
Axis 2 Brake Release	(3.4.5)
Axis 3 Amplifier Enable	(3.4.4)
Axis 3 Brake Release	(3.4.5)
Axis 4 Amplifier Enable	(3.4.4)
Axis 4 Brake Release	(3.4.5)

The CLM is designed so that various conditions must be satisfied to allow the servos to operate. If these conditions are not satisfied, the appropriate diagnostic message is displayed.

When the system is powered up, the CLM expects to receive Amplifier Ready inputs for each axis (#1 through #4) that has been enabled in parameters B000-B003, indicating the servo amplifiers and power supply have properly powered up and the amplifiers are ready for an Enable signal.

Assuming conditions are appropriate for operation, the CLM issues axis #1 through #4 Amplifier Enable outputs to allow the amplifier to operate and axis #1 through #4 Brake Release outputs to lift the spring-loaded servomotor brake (if using motor versions where brake is present).

3.2.3 Safety Interlocks

Inputs

Emergency Stop (3.3.3)

Motor Overtemp

Outputs

System Fault Indicator (3.4.6)

As described in the previous section, the CLM and its servos must perform operational checks and provide the proper signals to enable operation. There are other signals which serve as interlocks.

Emergency Stop -- The Emergency Stop input must remain high for the CLM to operate.

The system incorporates an Emergency Stop (E-Stop) chain. This is a circuit connected in series to both the CLM and the user's machine. Should any sensor in the E-stop chain open, all operations immediately stop. Note that the time taken to stop depends on the wiring method used, and inertia of the load connected to the servo motor on the machine.

Elements connected in the E-stop chain commonly include the Emergency Stop switch on the user's control panel; E-stop switch(es) on the machine; switches on lubrication or coolant pumps; and various safety interlock switches on guards and doors.

Motor Overtemp -- The thermally activated switch (TAS) of an Indramat MAC servomotor is typically connected to the respective Drive Ready input through a relay (to provide isolation for the motor power cable). If a motor overheats, the TAS opens and drops the +24 Vdc signal (de-energizing the relay, opening the Drive Ready input line). The "Drive Not Ready" diagnostic message is displayed and the system is halted. Although not a direct input to the CLM, this TAS circuit is important for servo motor protection.

There are several categories of faults, as described in Chapter 8. In general, once a fault is detected, an error message is displayed on the CLM display, the System Fault Indicator output turns OFF and all axes are decelerated to a stop.

The fault recovery procedure is to first troubleshoot and remedy the problem. Then, press the Clear key on the CLM control panel (or external **Clear** input on user control panel, see section 3.2.7) to clear the CLM fault status and diagnostic message on the display.

3.2.4 Normal Operation Signals

Inputs

- Cycle Start (3.3.4)
- Cycle Stop (3.3.5)

Outputs

- Axis Nearing Position (Pre Signal) (Ax07)
- Axis In-Position (Ax06)

The automatic execution of the user program begins when the **Cycle Start** line goes high (momentary) with the CLM in Automatic Mode. Once the automatic cycle begins, it is normally stopped by actuating the Error! Reference source not found. input (signal goes low). The system will also stop if an error is detected or if the CLM is switched to Manual Mode.

An auxiliary output can be assigned for each axis in parameters Ax07 (Position Pre-signal) to turn ON when the feed axis position is at a specified distance (in input units) from the target position of the commanded feed. Use this pre-signal when there is a need to anticipate the end of a feed, so another process can be initiated ahead of time. An example use would be to turn on a heater for bag sealing or plastic thermal forming operations. See Chapter 4 for further information on this parameter function.

NOTE: As described in Chapter 4, an "A" parameter set is provided for each axis (1 through 4). The first number after the "A" determines the axis number. Throughout this manual, when referring to an "A" parameter that effects all axes, an "x" is used in the second position to indicate 1, 2, 3, and/or 4.

An auxiliary output (**Axis In-Position**) can be assigned for each axis in parameters Ax06 to turn ON when the feed axis position is within the position threshold specified in the parameter. This position threshold does not affect the accuracy of the feed. It tells the program when to read the next program block (see PSI, PSA in Chapter 5). This output can be used to turn ON a light or buzzer on the user's control panel, or as a flag in the program to start a sub-routine program operation, etc. See Chapter 4 for further information on this parameter function.

3.2.5 Axis Homing

Inputs

Initiate Homing in Manual Mode

Home Switch

Outputs

Home Established Indicator

For absolute referencing of the axis with an incremental encoder, it is necessary to establish a correct measurement reference with the help of a homing routine. To initiate homing during manual operation, use auxiliary input signals (as defined in parameter Ax12); during automatic operation, by use of the "HOM" command.

Auxiliary inputs (Initiate Homing) can be assigned for each axis in parameters Ax12 to initiate the homing process in Manual Mode by a push-button switch or from a PLC output. Home position can be set to an Incremental Encoder marker pulse, or to a Home Switch (assign an auxiliary input for the home switch in parameter).

Homing each axis in Automatic Mode is accomplished through use of the HOM command (when using an incremental encoder). After reading in this command for one axis, the next block is read in with the same command for the second axis, allowing the homing procedure to occur simultaneously for both axes. Use an ATS command to monitor the Home Established auxiliary output (as set in parameter Ax12) to prevent reading any Absolute Position commands (POA, PSA) until the home procedure is finished.

3.2.5.1 Homing Procedure--Refer to Figure 3.4

1. Homing command is issued.
2. If the slide is not on the Home Limit switch, it moves in "reverse" at the Velocity 1 (V1) speed (set in Ax10) toward home until the switch closes. It will then decelerate, reverse direction and move "forward" at V2 speed (25% of V1) until the switch opens. If the slide is already on the switch when the command is issued, it moves forward off the switch at V2 speed.

NOTE: For any amount of travel that exists in the minus direction of the home switch point, the home switch must remain closed. The home switch dog must be at least as long as the reverse travel distance from the home switch.

3. The axis decelerates, reverses direction and creeps in the "reverse" direction at V3 speed (5000 pulses/second) passing and closing the Home Limit switch, and continues in the "reverse" direction at a super creep rate until the zero (or marker) pulse of the encoder occurs.

- The axis stops, then moves "forward" at V4 speed (500 pulses/second) until it senses the marker pulse (about 10 degrees of revolution), and records this as the zero position, then stops.

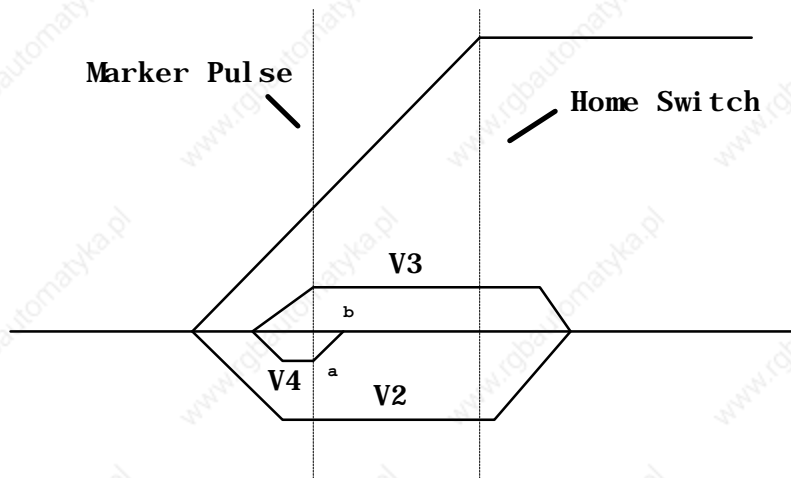

Figure 3-4 Axis Homing Routine

The zero pulse appears once in each motor revolution. The function of the Home Limit switch is to indicate the specific motor revolution in which the zero pulse is used.

In the homing procedure, regardless of the beginning position, the slide must stop on the Home Limit switch, closing it. The next zero pulse after the closing of the Home Limit switch indicates the reference position.

In many cases, some position other than home, such as the center line of the machine, is used as the reference position for machining. All programmed distances are then specified in reference to this point. This is established by entering the distance from home to the new reference location as the Reference Position (Homing Offset) in parameters Ax11. When the control is homed, this value will be loaded into the position counter, and all moves will be made in reference to this position.

Placement of the Homing Switch

As described above, the reference position of the AC servo drive is determined after it has moved onto the switch.

The reference position can be set in steps of one motor revolution each, by using the position the switch is in when it is activated. By monitoring the switching point of the homing switch and the marker pulse, a CLM diagnostic check eliminates the danger that these two are so close to each other that the switching tolerance limits will result in uncertainty about the motor revolution to be evaluated. If the switching point of the homing switch is closer than 1/16 of a motor revolution, with respect to the marker pulse, the control unit will not complete the homing process, and will change over to fault indication. The display will show: Marker Pulse 1? (or 2, 3, or 4, depending on the axis affected). The homing switch should be relocated by 1/3 of the feed constant.

Activating the Homing Switch

Activating the homing switch must be done in such a way that the switch closes upon backing up, i.e. upon the movement away from the work piece. The dog cam for activating the homing switch must be long enough so that the activation is not canceled by a continuing reverse movement up to the minus travel limit of the axis. This is required to indicate to the control unit in which direction the slide must be moved in order to approach the reference position.

Since the interrelationship between the direction of rotation of a servo motor and the movement away from, and toward, the work piece depends on the particular design of the machine, the homing direction must be also set correctly in the parameters.

If there is no marker pulse from the encoder within one revolution of the encoder, homing sequence is halted, and a fault is displayed. The display will show: "No Marker Pulse 1" (or 2, 3, 4 - affected axis).

Interruption of the Homing Routine

If, while in manual operation, there is a stop, an interruption, feed angle monitoring, or a switch of operating modes, the homing cycle is interrupted and must be restarted. After an interruption or stop occurs while in automatic operation, the homing cycle is restarted immediately by activating the Cycle Start input. After a fault or a change of operating modes during the homing cycle, the CLM must be re-initiated (switch to Auto Mode, press Cycle Start).

Over-travel Switches

It is recommended that you install forward and reverse over-travel switches on applications that have limited axis travel, such as a slide or a ballscrew driven axis. The switches can be wired either to the "drives ON" circuit or to the Cycle Stop input of the CLM. See appendix F for recommended interconnection. You must reserve distance beyond the limit switches to allow for deceleration of the axis to a stop.

3.2.6 Manual Operations

Inputs

Jog Forward (Axis 1)	(3.3.8)
Jog Reverse (Axis 1)	(3.3.9)
Jog Forward (Axis 2)	(3.3.8)
Jog Reverse (Axis 2)	(3.3.9)
Jog Forward (Axis 3)	(3.3.8)
Jog Reverse (Axis 3)	(3.3.9)
Jog Forward (Axis 4)	(3.3.8)
Jog Reverse (Axis 4)	(3.3.9)

Initiate Manual Vector Program

Outputs

None

The CLM's **Jog** inputs allow jogging of each axis forward and reverse. Parameter Ax01 specifies the jog feed rate for each axis. It usually is set to approximately 10% of the maximum feed rate. It can never be more than the maximum feed rate.

In Manual Mode, either axis can be jogged forward or reverse. The Jog inputs are not functional in Parameter or Automatic Modes. A high on the Jog Forward input causes the axis to feed forward at the velocity set in parameter. The feed continues as long as the Jog Forward remains high. The Jog Reverse operates similarly, jogging the axis in the reverse direction.

In order to make use of the software travel limits when in Manual Mode, the axis must be homed first. It is recommended to prevent jogging by interlock until home is established for the axis. The Home Established output (Ax12) can be used for this purpose.

An auxiliary input, **Initiate Manual Vector Program**, can be assigned in parameter B011 and used to initiate a user program to run in Manual Mode. This program may not contain any feed instructions and should not be located in the main program. Select by parameter to start this program by an external input (push-button switch) or automatically when mode is changed from Automatic to Manual. The program is aborted if switched out of Manual Mode. The manual vector is not accepted while jogging or homing in Manual Mode (see last section). Jogging or homing is not possible while the manual vector program is running.

An example use of the Manual Vector program is to use the APE command to set the states of auxiliary outputs. This command is programmed to set a bank/group of ten outputs individually to ON, OFF or Don't Care states. This allows setting outputs for a "shut-down" mode, or as default before starting automatic operation. See Chapter 4 for additional information on parameters and Chapter 5 for programming commands.

3.2.7 Fault/Diagnostic Monitoring

Inputs

Clear (External)	(3.3.7)
Restart Select	(3.3.10)

Outputs

System Fault Indicator	(3.4.6)
Restart Possible Indicator	(3.4.7)

The CLM includes extensive diagnostic monitoring circuitry, detecting normal operating status, operator errors, errors in the control itself and machine faults.

There are several categories of faults, as described in Chapter 8. In general, once a fault is detected, an error message is displayed on the CLM display, the System Fault Indicator output turns OFF (turns OFF “System OK” or turns ON “Fault” light, driven by relay, on user control panel) and both axes are decelerated to a stop.

The fault recovery procedure is to first troubleshoot and remedy the problem. Then, press the Clear key on the CLM control panel (or external **Clear** input on user control panel) to clear the CLM fault status and diagnostic message on the display.

If the user program is interrupted by a power loss, system error or mode change, the status of outputs, absolute target position and velocity are temporarily stored in memory. Parameter 56 can be used to define the starting program block for a Restart Vector routine. Based on the type of error and system configuration, it may be possible to restore the status of the CLM as before the interrupt. This is indicated by the **Restart Possible** output (ON = restart possible, OFF = restart not possible). The Restart Vector routine is initiated by a momentary input pulse, OFF to ON, from the **Restart Select** input. The Restart Vector program should start with the RSV command. See Chapter 5 for information on programming commands. See Chapter 4 for further information on this parameter function. Diagnostics and fault troubleshooting procedures are described in Chapter 8.

3.2.8 Feed Monitoring / Program Interruption

Inputs

Interrupt Vector Program
Feed Angle, Axis 1
Feed Angle, Axis 2
Feed Interrupt , Axis 1
Feed Interrupt , Axis 2

Outputs

None

An auxiliary input, **Interrupt Vector/Program**, can be assigned in parameter B012 to interrupt the user program at any time and start an Interrupt Vector sub-routine program (Automatic Mode only). When this input goes high, the current program sequence will be interrupted immediately or after the current sub-routine program is finished (option set in parameter). The program sequence will then continue at the start program block number assigned in the parameter for the Interrupt Vector program. See Chapter 4 for further information on this parameter function.

An auxiliary input, **Feed Angle Monitoring**, can be assigned for each axis in parameter Ax20 to prevent the program from executing any feed length commands. The CLM will process all program blocks not containing any feed lengths. If there is no signal at the assigned input, the program continues to execute until it processes to a block containing a feed length. The CLM will stop in this block until there is a signal at the input. If the input signal turns OFF during a feed, the feed will be stopped and an error message will be displayed.

An auxiliary input, **Feed Interrupt (Feed Hold)**, can be assigned for each axis in parameter Ax40 to prevent the program from executing any feed length commands. The CLM will process all program blocks not containing any feed lengths. If the input is low, the program continues to execute until it processes to a block containing a feed length. The CLM will stop in this block until the assigned input goes high. If the input goes low during a feed, the feed will be stopped. Feed will automatically resume as soon as the signal goes high.

An example of use for this signal is in conjunction with a material loop. Material is fed from an uncoiler into a looping pit, with an optical sensor in the pit tied to the **Feed Interrupt** line. If the material pulls too tight, the signal goes low and the feed cycle is interrupted. As soon as an adequate amount of material is fed into the looping pit, the signal returns high and the feed cycle immediately resumes. Another example of use for this signal is in conjunction with a press type system. For a punch press, this signal would come up shortly after the ram clears the material on its upstroke. The signal would drop (go low) on the ram downstroke, allowing some safety margin before the ram reaches the material. The material feed must have stopped before this signal drops. See Chapter 4 for further information on this parameter function.

WARNING: If the automatic cycle is interrupted by a low on the **Feed Interrupt** line, all feed motion is suspended. Once this signal is restored high, the feed cycle will **immediately** resume. The work area should not be entered if the feed has stopped as a result of this signal.

3.2.9 Special Functions

Inputs

Detect Registration Mark (High Speed)	(3.3.11)
Position Loop Reset	
Interrupt Vector/Program	
Enable Measuring Wheel Operation and Dual Encoder Option	

Outputs

Acknowledge Roll Lifting Active
Achieved Programmed Velocity

An auxiliary input, **Detect Registration Mark**, can be assigned in the REF program command to cause the CLM to search for a registration or reference mark on the material. To provide this input signal, use a sensor which detects a printed mark or stamp on each piece of material. A high signal must be present on this input when a reference mark is present under the sensor.

The accuracy and duration of this signal is essential to the proper operation of position correction, especially if the mark needs to be detected at high speeds. Three **high speed inputs** are provided for this specific purpose. They can detect an input signal of 150 microseconds duration, compared to the 2 to 4 milliseconds duration required for other inputs. Refer to the REF program command in Chapter 5 for additional information on using this feature.

For **Measuring Wheel operation**, set options in parameters B009 and B010. These parameters establish the feed rate constant and the number impulses of the measuring wheel encoder. They also allow assigning an auxiliary input for selecting measuring wheel or motor encoder feedback. During measuring wheel operation, the measurement of lengths is from the measuring wheel encoder, rather than the integral motor encoder.

The Dual Encoder Option in parameter B008 allows quicker response with measuring wheel operation. When selected, the position loop is closed using motor encoder feedback and the measuring wheel encoder provides adjustments to the length during feeding. When this option is not selected, the Position Loop is closed using the measuring wheel encoder. Lack of stiffness in the mechanical components between the motor and the wheel can require using a lower gain, which increases the response time.

During manual operation, the position feedback always comes from the motor encoder. During automatic operation, there is a choice between continuous measuring wheel operation and using an auxiliary input signal to select measuring wheel operation.

The following conditions must be met:

- The material is in the feed rolls and under the measuring wheel
- The feed rolls are closed
- The measuring wheel is pressing against the material

If one of the above conditions is not met, the drive can run temporarily out of control until it is stopped through an internal error detection procedure of the control unit.

Error messages are:

- Encoder Error
- Drive Runaway

If the feed roll has to be lifted in conjunction with the measuring wheel operation, the auxiliary input signal must be used to discontinue the "measuring wheel operation" while the roll is lifted. Care must be taken that the timing is correct during the cycling of the feed rolls contacting and releasing from the material. Refer to Chapter 4 for additional information on this parameter function.

Auxiliary inputs, **Position Loop Reset inputs**, can be assigned in parameters Ax15 for each axis. This function allows shifting of the incremental position without causing a position fault. This parameter also allows user assigned auxiliary outputs to indicate when Position Loop is reset and separately, when the programmed velocity has been achieved. There are mechanical limitations that must be considered when using this function. Consult a Indramat CLM Application Engineer for additional requirements. Refer to Chapter 4 for additional information on this parameter function.

3.3 Input Signal Descriptions

This section describes the Inputs to the CLM control from external sources. The Input and Output signal lines of the CLM are optically isolated from the CLM's internal bus structure to minimize electrical noise interference.

The connectors and pin numbers of these signals are described in the following sections and shown in Figures 3.1 (X3) and 3.3 (X22).

3.3.1 Parameter Mode Select

Connector	X3, pin 1
Function	(Input) Selects Parameter Mode
+24 Vdc	Parameter Mode selected.
0 Vdc	Parameter Mode is not selected; another mode is selected or the system has defaulted to the Manual Mode.

The Parameter Mode Select will override any other mode selection input. If properly wired, selecting Parameter Mode while Automatic Mode is already selected, does not cause an error. When Parameter Mode is deselected, the CLM returns to the previously selected mode - Automatic or Manual (default when no other modes are selected).

NOTE: Task 3 stops in Parameter Mode.

3.3.2 Automatic Mode Select

Connector	X3, pin 2
Function	(Input) Selects Automatic Mode
+24 Vdc	Automatic Mode selected.
0 Vdc	Automatic Mode is not selected; another mode is selected or the system has defaulted to the Manual Mode.

If this signal line is high at the same time the Parameter Mode is selected (input high), the CLM issues the "Invalid Mode Selection" diagnostic error message.

NOTE: Task 3 will be running in either Manual or Automatic Mode.

3.3.3 Emergency Stop

Connector	X3, pin 3
Function	(Input) Commands Motor Drive to immediate stop
+24 Vdc	Allows the CLM to operate
0 Vdc	The motor drive is commanded immediately to zero velocity. Drive reaches zero speed in the minimum time possible; given the inertia and maximum torque available. The CLM issues an "Emergency Stop" diagnostic message

WARNING: This signal must be used to ensure safety.

Conditions which warrant pressing the E-Stop include:

- Any condition posing an immediate danger to personnel.
- A jam in the machinery or any other condition that poses an immediate harm to the system equipment.

NOTE: E-stop is the only error that will allow Task 3 to operate.

3.3.4 Cycle Start

Connector	X3, pin 4
Function	(Input) Starts automatic feed cycle
+24 Vdc	(momentary) Starts the execution of Task 1 and 2 when the CLM is in the Automatic Mode.
0 Vdc	Has no effect on the system operation. <u>Once initiated</u> , only a system failure (fault or error), the presence of the <u>Emergency Stop</u> or <u>Feed Interrupt</u> (or user defined <u>Feed Interrupt</u>) will halt the automatic cycle.

This input is typically wired to a normally open push-button switch on the user control panel.

NOTE: Task 3 will be running in either Manual or Automatic Mode.

3.3.5 Cycle Stop

Connector	X3, pin 5
Function	(Input) Used to stop the automatic cycle
+24 Vdc	(Continuous) Allows Automatic Mode operation.
0 Vdc	(Momentary) Stops Automatic Mode cycling.

This input is typically wired to a normally closed push-button switch on the user control panel.

NOTE: None of the axes can be jogged when this input is low.

3.3.6 Amplifier Ready (Axis #1 through #4)

Connector	X3, pin 6 (axis 1)
Connector	X3, pin 7 (axis 2)
Connector	X22, pin 1 (axis 3)
Connector	X22, pin 4 (axis 4)
Function	(Input) Informs the CLM that the relevant Axis Amplifier is ready for operation
+24 Vdc	relevant Axis Amplifier has power applied and is ready to be enabled.
0 Vdc	After power-up, typically indicates either a power loss at the servo power supply or relevant amplifier, or an internal fault in the amplifier.

This input originates at the ready (Bb) contact of the relevant servo amplifier. Chapter 6 describes these connections, as required for installation.

3.3.7 Clear (External)

Connector	X3, pin 8
Function	(Input) Clears the Hard or Soft Fault status of the CLM
+24 Vdc	(momentary)- Clears the Soft Fault status of the CLM, or Clears the Hard Fault status and re-initializes the CLM.
0 Vdc	Has no effect.

Once a fault occurs, the CLM displays a diagnostic message (refer to Chapter 8). The operator must then physically correct the problem. Next, the operator must press the Clear key on the CLM control panel or the Clear button on the user's control panel, to clear the diagnostic message.

This signal is typically wired to a normally open push-button switch on the user control panel.

NOTE: Task 3 will start as soon as the error is cleared.

3.3.8 Jog Forward (Axis 1 through 4)

Connector	X3, pin 9 (axis 1)
Connector	X3, pin 11 (axis 2)
Connector	X22, pin 2 (axis 3)
Connector	X22, pin 5 (axis 4)
Function	(Input) Jogs the axis forward
+24 Vdc	In Manual Mode, the axis feeds forward at the velocity set in Parameters Ax01. The axis will feed forward as long as the high signal is present (switch held closed).
0 Vdc	In Manual Mode, stops forward feed (switch released) after started with a high signal (switch was closed).

This input is typically wired to a normally open push-button switch on the user control panel.

Jog Forward is not functional when the CLM is in the Parameter or Automatic Mode.

3.3.9 Jog Reverse (Axis 1 through 4)

Connector	X3, pin 10 (axis 1)
Connector	X3, pin 12 (axis 2)
Connector	X22, pin 3 (axis 3)
Connector	X22, pin 6 (axis 4)
Function	(Input) Jogs the axis in the reverse direction
+24 Vdc	In Manual Mode, the axis feeds in the reverse direction at the velocity set in Parameters Ax01. The axis will feed in reverse as long as the high signal is present (switch held closed).
0 Vdc	In Manual Mode, stops reverse feed after started with a high signal.

This input is typically wired to a normally open push-button switch on the user control panel.

Jog Reverse is not functional when the CLM is in the Parameter or Automatic Mode.

3.3.10 Restart Select

Connector	X3, pin 15
Function	(Input) Initiates a Restart Vector program
+24 Vdc	(momentary)- Initiates a Restart Vector program after a power loss, system error, or change from Automatic to Manual Mode while cycling, if a restart is possible.
0 Vdc	Has no effect.

Parameter B014 can be used to enable this function and define the starting program block for a Restart Vector routine. The Restart Possible output will indicate if restart is possible. This input is typically wired to a normally open push-button switch on the user control panel.

3.3.11 High Speed Registration Mark Detect

Connector X3, pin 16

Connector X22, pins 7 and 8

NOTE: Inputs for connector X22, pins 7 and 8, are not fully implemented at this time. Check with an Indramat Application Engineer for current status before using.

Function (Input) Informs the CLM when a registration mark is present on the material

+24 Vdc (momentary)- A registration mark is detected (sensor is over a mark on the material).

0 Vdc A registration mark is not currently being detected.

These inputs can be assigned in the REF program command to cause the CLM to search for a registration or reference mark on the material. This input must be wired to a high speed sensor which will detect a printed mark or stamp on each section or piece of material being fed (signal duration of at least 150 microseconds). Refer to REF command in Chapter 5 for additional information on use of these inputs.

3.4 Output Signal Descriptions

This section describes the outputs from the CLM control system to external devices. CLM input and output lines are optically isolated from the CLM's internal bus structure to minimize electrical interference. The connectors and pin designation of these signals are described in the following sections and shown in Figures 3.2 (X4) and 3.3 (X22).

3.4.1 Manual Mode Indicator

Connector	X4, pin 1
Function	(Output) Indicates that Manual Mode is active
+24 Vdc	No other modes are selected. The CLM defaults to Manual Mode.
0 Vdc	Another mode is selected or an error has occurred.

This output signal is typically wired to an indicator light on the user control panel or to a PLC.

3.4.2 Automatic Mode Indicator

Connector	X4, pin 2
Function	(Output) Indicates that Automatic Mode is active
+24 Vdc	Automatic Mode is selected.
0 Vdc	Another mode is currently selected, or normal conditions that allow Automatic Mode operation are not satisfactory, or a fault is preventing entry into Automatic Mode.

This output signal is typically wired to an indicator light on the user control panel or to a PLC.

3.4.3 Parameter Mode Indicator

Connector	X4, pin 3
Function	(Output) Indicates that Parameter Mode is active
+24 Vdc	Parameter Mode is selected. This overrides any other mode selection.
0 Vdc	Parameter Mode is not selected.

This output signal is typically wired to an indicator light on the user control panel or to a PLC.

3.4.4 Amplifier Enable, RF (Axis #1 through #4)

Connector	X7, pin 1 (Axis #1, RF1)
Connector	X7, pin 2 (Axis #2, RF2)
Connector	X19, pin 6 (Axis #3, RF3)
Connector	X19, pin 7 (Axis #4, RF4)
Function	(Output) Enables respective Axis Amplifier
+15 Vdc	Enables the respective Axis Amplifier for operation.
0 Vdc	respective Axis Amplifier is faulty (respective Axis Amplifier Ready input is missing), the CLM is in the Parameter Mode, or a Hard Fault condition exists.
Connector	X4, pin 4 (Axis #1, RF1)
Connector	X4, pin 7 (Axis #2, RF2)
Connector	X4, pin 15 (Axis #3, RF3)
Connector	X4, pin 16 (Axis #4, RF4)
+24 Vdc	Amplifier Enable signal. A 50-mA output, sufficient for sending to a PLC to confirm Axis Enabled.
0 Vdc	respective Axis Amplifier is faulty (respective Axis Amplifier Ready input is missing), the CLM is in the Parameter Mode, or a Hard Fault condition exists.

3.4.5 Brake Release (Axis #1 through #4)

Connector	X4, pin 5 (Axis #1)
Connector	X4, pin 8 (Axis #2)
Connector	X22, pin 17 (Axis #3)
Connector	X22, pin 18 (Axis #4)
Function	(Output) Controls respective servomotor brake (when so equipped)
+24 Vdc	All power-up initialization and verifications are correct and the respective Axis motor brake is electrically lifted - disengaged (unless motor brake circuit faulty).
0 Vdc	The respective motor brake is engaged (mechanically).

The motor brake is spring loaded. When +24 Vdc is applied, the brake is electrically lifted from the motor. When the voltage is removed, the spring action of the brake engages it to the motor shaft.

3.4.6 System Fault Indicator

Connector	X4, pin 6
Function	(Output) Indicates a fault has occurred
+24 Vdc	The system is functioning properly
0 Vdc	The CLM has detected a fault

This output is typically wired to an indicator light (ON when no fault is present) on the user control panel, or the signal is relayed to a buzzer when 0 Vdc occurs.

NOTE: Any Hard Fault will turn OFF this output. See Chapter 8 for a description of faults.

WARNING: This output is a semiconductor that should not be relied upon in the event of an emergency condition. If this signal is used, it should be in conjunction with the Bb contacts of terminal X5.

3.4.7 Restart Possible Indicator

Connector	X4, pin 9
Function	(Output) - Indicates if it is possible to restore the status of the CLM as before the program was interrupted by a power loss, system error or mode change by executing a Restart Vector program.
+24 Vdc	Restart is possible.
0 Vdc	Restart is NOT possible.

Parameter B014 can be used to enable this function and define the starting program block for a Restart Vector routine. The Restart Possible output will indicate if restart is possible.

This output is typically wired to an indicator light on the user control panel or to a PLC.

4. PARAMETERS

This chapter describes the user entered parameters required for the CLM to perform the motion control operation. The user adapts the CLM to his machine and the mechanical characteristics of the application by entering values for various parameters. These parameters permit a standard control system to conform to different but similar applications. It also assures that all application programs are written with a uniform data format. The user must enter parameter values into the CLM memory prior to the operation and programming of the CLM control.

NOTE: All values for parameters must be known before an application program can be written. If a function is programmed or attempted which would exceed the bounds established by the parameters, the control will halt and a diagnostic error will be displayed.

4.1 Description of Parameter Sets

The CLM includes the following sets of parameters.

Parameter Set A:

This axis oriented parameter set includes the axis operating values for Automatic and Manual Mode operation. These parameters allow the user to configure the CLM for the motor and drive package that the CLM is controlling. They also allow the user to set the various factors of the motion profile, as required for the material and application. These include the resolution of the feed, acceleration and deceleration rates, feed rates in different modes, etc.

Each of the up to four axes have separate but identical parameter sets (A1xx-A4xx), as described in the next section.

Parameter Set B:

This system oriented parameter set establishes the operating arrangement of the CLM. It allows the user to configure the CLM for various options such as the language that shows on the display (English, German, Spanish or French); selecting control interface options, such as the IDS or SOT; selecting and configuring other optional features like synchronization, multi-tasking, axis enable, etc.

4.2 Parameter List

Table 4-1 lists all of the parameters for the CLM-01.3-A with software version LA01.3-01.x.

NOTE: A separate but identical "A" parameter set is provided for each axis (1 through 4). The first number after the "A" determines the axis number. In the following table, substitute the axis number (1, 2, 3, or 4) for the "x" following the A. Throughout this manual, when referring to an "A" parameter that effects all enabled axes, an "x" is used to indicate axis 1, 2, 3, and/or 4.

Table 4-1 Parameter List

Axis Parameters		System Parameters	
Ax00	Max Velocity	B000	Enable axis 2
Ax01	Jog Velocity	B001	Enable axis 3
Ax02	Acceleration Rate	B002	Enable axis 4
Ax03	Position Gain	B003	Serial Interface
Ax04	Enc Lines/Revolution	B004	Serial Interface
Ax05	Absolute Data	B005	Memory Display
Ax06	Position Tolerance	B006	Start Task 2 & 3
Ax07	Position Pre-signal	B007	Language
Ax08	Feed Constant	B008	Variations
Ax09	Direction	B009	Free
Ax10	Homing Setup	B010	Free
Ax11	Homing Offset	B011	Manual Vector
Ax12	Homing Acknowledge	B012	Interrupt Vector
Ax13	Min Travel	B013	Analog Input
Ax14	Max Travel	B014	Restart Vector
Ax15	Special Functions	B015	Cycle Time
Ax16	Rotary Table	B016	Measuring Wheel Encoder 1
Ax17	Knee Point	B017	Measuring Wheel Encoder Lines/Rev
Ax18	Polum. Max. (Position Max.)	B018	Measuring Wheel Feed Constant
Ax19	Polum. Min. (Position Min.)	B019	Measuring Wheel Offset
Ax20	Feed Angle Monitor	B020	Free
Ax21	Drive Input Sensitivity	B021	Free
Ax22	Monitor Window	B022	Free
Ax23	Follow/Sync. Measuring Wheel	B023	Free
Ax24	Free		
Ax25	Free		

4.3 Entering the Parameters

The CLM must be in Parameter Mode to enter or edit parameters, and the E-Stop signal must be present (+24 Vdc at connector X3, pin 3). The Parameter Mode is normally selected via a switch on the user control panel. This selector switch will typically require a key to enter this mode to prevent unauthorized changes to the parameter values.

Parameters are entered or changed by writing over any previous data stored. These changes are made through the CLM keypad (or via a serial interfaced host). A Lithium backup battery assures this memory is retained when the CLM is powered down or if the system experiences a power loss.

In Parameter Mode, the CLM display shows the parameter name, number and data value of the parameter selected, as illustrated below.

Max Velocity
A100 00200000

When selecting Parameter Mode, the display shows the first parameter of the A set of parameters (A100), unless a fault exists, as described later in this section. The parameter display appears with the cursor on the first digit of the parameter data field. Use the right / left arrow keys to move the cursor in the field. Enter or change a Parameter's data by writing over any previous data stored. Press the Store key to save the data change. The display automatically changes to the next parameter number in the parameter set.

The following conditions will cause a parameter data change to revert back to the values last saved, if performed BEFORE pressing the Store key:

- Pressing the CL key (clear entry),
- Waiting 10 seconds after the last change,
- Scrolling to another parameter,
- Exiting Parameter Mode.

The parameter displays are visible in the CLM's control panel display, and on the optional SOT or other host, via the RS-232/422/485 serial interface, when used.

NOTE: The optional remote florescent tube display, available with the IDS option, will only display the message Parameter Mode while the CLM is in this mode. The two digit display on the IDS shows code number 17 when this mode is selected.

When first entering parameter data, an asterisk (*) appears in the specific digit positions of the data field where an entry must be made. Appendix E provides blank parameter entry forms which show the required entry positions. Always maintain an accurate listing of your parameter entries for reference when troubleshooting or changing parameters for a different application.

To select other parameters to display, first move the cursor onto the parameter number by pressing the CR key. If the cursor is within the data field, pressing CR once will cause it to move to the beginning of that field. Press it again to move the cursor to the beginning of the previous field. The left and right arrow keys will also move the cursor within and between fields.

To change from one axis parameter set to another, move the cursor to the first position after "A" (or "B") and enter 1, 2, 3, or 4 to view/edit the appropriate axis parameter set; enter 0 to change to the "B" parameter set (system parameters).

With the cursor on the parameter number, type over to enter the parameter number desired to display. The display changes as the new parameter number is entered. Pressing the arrow keys will also cause the parameter display to change to the next higher (up arrow) or lower (down arrow) parameter number within the axis parameter set. Pressing the CL key causes the parameter display to jump ahead to the next decade parameter number (i.e. A100, A110, A120, etc.).

Perform the following steps to change or edit the value of a parameter (from the CLM control panel; see Chapter 7 for procedures to download from a PC or SOT via the serial interface):

1. Move the cursor (arrow keys) over the digit you want to change.
2. Enter the desired number from the CLM keypad (type over existing entry).
3. Verify data changes are correct in the display.
4. Press the Store key to save the new parameter values (displayed data) into memory. The display automatically changes to the next parameter.
5. Repeat this procedure to change each parameter required by your application. Maintain a current list of parameter entries. **Appendix E** provides work sheets which show the organization of each parameter and provide spaces to list each entry.

NOTE: Should the displayed message appear in a language other than the language desired by the user, enter the B Parameter Set and scroll to B007. Change the display to the desired language, as explained for parameter B007 in this chapter (field entry of 01xxxxxx will cause a display in English).

The CLM checks the parameter values each time it is powered ON, as well as each time parameters are read in. If there are parameters that are incorrect or missing, an appropriate error message will be displayed.

Upon exit from the Parameter Mode, if any parameters have been changed, internal buffers that are dependent on parameter values will be re-calculated. During that time the display will show the message "Please Wait!" If you have entered a value higher or lower than the limits of the parameter, the display will show the error message "Is Invalid". Switch back to Parameter Mode. The first invalid parameter description and number will display. In place of the data, the message "Is Invalid" appears.

**Max Velocity
A100 Is Invalid!**

Press the CL key to clear the fault status message. The display returns to the normal parameter entry display. Enter correct values for the parameter (within limits).

4.3.1 Displaying of Decimals

It is important to note that decimal points are not shown on the CLM display when entering parameters. They are implied, as defined in the following parameter lists and definitions.

This manual describes a CLM software version that has programmable decimal positions. This version has two or three decimal places in the commands that involve positioning. Specific decimal places allowed for parameters and commands are listed in their specific description in Chapters 4 and 5. The number of decimal digits (can be up to 5) depends on the selection you set in Parameter B007. You must set this parameter before the other ones can be derived.

NOTE: If the decimal precision is not programmed in B007, "Is Invalid Language" diagnostic will appear when switched out of Parameter Mode. When switched back to P-Mode, the parameter with incorrect entry is displayed.

4.3.2 Auxiliary Inputs/Outputs

Certain parameters require the selection of auxiliary outputs or auxiliary inputs (Acknowledgments) to be used. The auxiliary numbers to use must be selected by the machine builder and shown on their interconnect drawings, where applicable. Each auxiliary output selected should be unique; i.e. A106 and A206 should not use the same auxiliary output number.

WARNING: Auxiliary input and output numbers that have been dedicated by the machine builder for a specific purpose must not be changed. Personal injury or damage to the machine/drive train could result from such changes.

4.3.3 Unit of Measurement

The user specifies most parameter data in terms of input units (IU). A unit is defined by the user, and can be feet, inches, millimeters, degrees, radians, etc. Once the user has chosen the unit of measurement, then all position and feed rate data must be in accordance to that unit, where it is logically required.

For example, the input unit could be specified as inches. The maximum feed rate in parameter A100 might be programmed as 12 inches/second. The acceleration parameter would then be in units of inches per second squared. Note that positioning commands for the application program are to two or three decimal places. If you require positioning to 0.001", set the decimal selection in parameter B007 to three places. In general, when using US System (inches) measurements, set B007 for three decimal places. When using Metric (millimeters), set B007 for two decimal places.

4.4 Linear or Rotary Operation

The CLM is capable of Linear or Rotary operation for each axis. Most applications will utilize the linear method of programming (i.e. Ball Screw, Belt, Slide). Some applications require the special features allowed with rotary programming (Ax16 - Rotary Axis Gear Ratio).

Linear operation (programming) allows each axis minimum and maximum software over-travel limits (effective after the axis has been Homed). Motions can be programmed in any type of Input Units (i.e. inches, mm, degrees, etc.).

Rotary operation (programming) allows each axis the capability of 360 degrees of motion. The actual position screen (L P Screen), counts from 0 degrees to the value set in Ax08, resetting back to zero after each complete revolution (360 degrees). Each axis can be programmed to make multiple revolutions in either direction (direction is relative to the programming of Ax09 - Direction of Operation). The software over-travel limits are disabled when implementing rotary programming.

4.5 Parameter Descriptions

The following sections describe each parameter, as required for the CLM to command motion. Each parameter description includes an illustration of the CLM display and the formula required to obtain the parameter value, where applicable.

For easy reference, this section describes each parameter in numerical order, (Ax00 through Ax25, then B000 through B023), as shown in Table 4.1, and each new parameter begins on a new page. The parameter description for A100 is the same for A200, A300 and A400, only the axis number is different. Therefore, this section combines the common descriptions for the A parameter set, using "x" to indicate any axis 1 through 4.

NOTE: Enter parameter data for axis 1 in parameters A100-A125, for axis 2 in parameters A200-A225, etc. Also enter system parameter data in parameters B000-B023. Parameters Ax08 (Feed Constant) for each axis must be determined before the velocity parameters can be entered correctly. These parameters set the Input Units for each axis movement.

4.5.1 Parameter Ax00 - Maximum Velocity, Axis 1 - 4

Max Velocity Ax
Ax00 00123456

- Min.: 00000.100 IU
- Max.: 50000.000 IU

This parameter defines the maximum velocity for the axis (1-4), entered in Input Units (defined in Ax08). All motion commands are a percentage of this maximum velocity. Velocity is specified in Input Units/second to two or three decimal places. Set the decimal resolution in B007 before entering this parameter.

A motion command programmed for 99.9% velocity results in a travel velocity equal to the maximum velocity (100.0%). All lesser numbers programmed, results in a travel velocity equal to the actual percent of maximum velocity entered.

The formula for calculating the max. velocity is :

$$\text{Max Velocity} = \frac{\text{Max RPM (@ 10V)} \times \text{Feed Constant (Ax08)}}{60} \text{ (input units/sec)}$$

NOTE: Any gear ratio between the motor shaft (input shaft) and the output shaft is taken into consideration in the calculation of the Feed Constant (Ax08).

Example: Linear Maximum Velocity Calculation

Input sensitivity of the amplifier = 1500 RPM @ +10V

Feed Constant = 2.441 IU's per rev.

$$\begin{aligned} \text{Max Velocity} &= 1500 \text{ rev/min} \times 1 \text{ min/60 sec} \times 2.441 \text{ IU/rev} \times 1500 \text{ RPM/60 sec} \times 2.441 \text{ IU} \\ &= 61.025 \text{ IU/sec} \end{aligned}$$

The entry in Ax00 would be <00061025> for the system maximum, or a percentage of this number for your preferred maximum velocity.

NOTE: Always round the result down; i.e. if the result was 66.6667, the entry would be 66.666.

4.5.2 Parameter Ax01 - Jog Velocity, Axis 1 - 4

Jog Velocity Ax Ax01 00123456

This parameter specifies the maximum velocity that axis 1-4 can be jogged in manual mode. It is specified in input units/second, to two or three decimal places. Set the decimal resolution in B007 before entering this parameter.

You specify this velocity in the same manner as in Ax00, but define the velocity to be used for jogging, rather than the maximum velocity.

Hint - Start at 10% of Ax00 entry, then increase or decrease as required for the application.

4.5.3 Parameter Ax02 - Acceleration, Axis 1 - 4

Accel Rate	Ax
Ax02	12345678

The axis accelerates and decelerates at the rate specified by this parameter.

This parameter provides a protection for the machinery as it can limit the amount of torque produced during speed changes. The amplifier drive system must be capable of acceleration at the rate specified here. If not, an overshoot or an error message may occur during a speed change.

The parameter value is specified in input units /second² (units/second/second), in whole units (0 decimal places) or to one decimal place. Set the decimal resolution in B007 before entering this parameter.

For example:

To program the machine in the force of 1G, assuming your Input Units are programmed in inches,

$$1G = 32.16 \text{ feet/second}^2$$

Convert to inches, (input units, inches used in this example)

$$32.16 \times 12 = 386.0 \text{ inches/second}^2$$

For an Accel/Decel rate of 1G,

Enter parameter data <00003860>

Multiply or divide this number for a rate of 2G, 1/2 G, etc.

Use similar procedures to program in factors other than G force.

NOTE: Parameter Ax17, Knee Point, can be programmed to select a second acceleration / deceleration rate based on velocity.

4.5.4 Parameter Ax03 - Position Gain (KV Factor) Axis 1 - 4

Position Gain Ax Ax03 000001234
--

- Minimum: 0.01
- Maximum: 20.00

This is the position gain of the system for the axis (1-4).

The standard machining Kv Factor = 1. Entering a larger number (higher gain) will yield a tighter system (less following error). Entering too large a number can result in overshoot, oscillation, sporadic faults, and/or high wear on the system parts (bearings, chains, gears, etc.). Set this parameter for optimum high performance (not necessarily maximum) for your system.

Input is specified to two decimal places.

Hint: A gain of 3 to 5 is typical when the motor is matched to the load inertia.

This entry sets the amount of velocity command given to the amplifier per a given position error (deviation). The following error (deviation) while feeding is inversely proportional to the KV selected.

$$KV = \frac{Vel}{1000 \times FE} \quad \text{or} \quad FE = \frac{Vel}{1000 \times KV}$$

Where:

- Vel (velocity) is in IU/minute
- FE (following error) is in IU's (input units)
- KV=Velocity (in IU/minute) per thousand IU of Following Error

4.5.5 Parameter Ax04 - Incremental Encoder Data, Axis 1 - 4

Enc Lines/Rev Ax Ax04 00001250
--

- 0000 - Not used
- 1250 - Incremental encoder lines /revolution
- Minimum: 00000100
- Maximum: 00005000

This parameter specifies the number of line counts from the incremental encoder, per encoder revolution. The CLM determines the encoder/ motor revolutions, based on this entry. This data is used in several different computations which affect positioning.

The information for this entry is provided on the data plate of the incremental encoder mounted on the rear of the servo motor.

If using an Absolute encoder, enter <00000000> for this parameter and see Ax05.

4.5.6 Parameter Ax05 - Absolute Encoder Data, Axis 1 - 4

Absolute Data Ax
Ax05 12345678

- 1234 - number of revolutions (including ratio of encoder to motor, if applicable); maximum number of turns of the absolute encoder before it either physically stops or the point it rolls over back to 0.
- 5678 - resolution of encoder in steps per 360 degrees revolution of encoder; number of pulses (bit count) per revolution of the encoder.

This parameter is required when an absolute encoder is used.

The first set of digits specifies the number of revolutions of the encoder for the entire set of data. The second set of digits specifies the number of increments per encoder revolution. The absolute encoder is activated in parameter Ax10.

The information for this entry is provided on the data plate of the absolute encoder.

If using an incremental encoder, enter <00000000> for this parameter and see Ax04.

The number of revolutions of the encoder must be precisely an even power of 2. One of these numbers must be selected for each set of digits: 1, 2, 4, 8, 16, 32, 64, 128, 256, 512, 1024, 2048, or 4096. The resolution of the encoder can be one of the preceding numbers, with the exception of 1, 2, 4 or 8.

Example:

- Number of encoder revolutions = 256
- Resolution of encoder = 1024
- Ax05 entry: <02561024>

4.5.7 Parameter Ax06 - Position Tolerance, Axis 1 - 4

Position Tol	Ax
Ax06	15000010

- 15 - auxiliary output number to be turned on when position reached.
- 000010 - Position tolerance to two or three decimal places. Set the decimal resolution in B007 before entering this parameter. i.e.. <XX000010 = 0.010 IU>

This parameter sets the positional band tolerance for the axis (1-4). It is defining a window in which the CLM will consider the axis in position. Adjusting this tolerance does not affect the accuracy of the move. It tells the control when to read the next command line (see PSI, PSM in chapter 5) and to turn ON the auxiliary output. The first two digits specify the output number that will turn ON when the axis is in position. You can use this output to turn on a light, buzzer or as an internal flag. If no output is needed, a "00" can be programmed or an output that is not physically accessible (20 to 72) can be programmed.

NOTE: The auxiliary output number must be unique to all other parameter selected auxiliary outputs; i.e. A106 is output #15, A206 cannot be output #15 (even if axis 2 is not used).

The remaining digits are the switching threshold (position tolerance), entered in input units. A typical setting is 5 thousandths of an inch. The second half of the entry would be <000005>.

The following sketch shows an **example** of switching threshold:

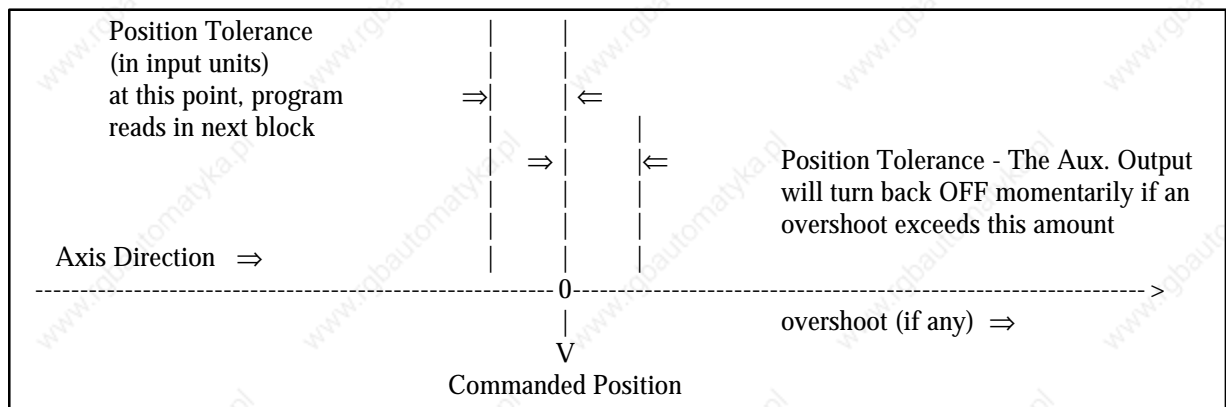

NOTE: A properly tuned system does not overshoot. See Ax02 and Ax03. If overshoot occurs, the acceleration rate and/or gain may be set too high.

4.5.8 Parameter Ax07 - Position Pre-Signal, Axis 1 - 4

```
Pos Presignal Ax
Ax07      14021234
```

- 14 - auxiliary output number to be turned on (00=not activated)
- 02 - time in 0.1 seconds (0.1 - 9.9 in 0.1 increments)
 - 00 = output as a constant signal which stays on until next feed or a command AEA (output ON/OFF).
- 1234 - Pre-signal distance in Input Units (zero or one decimal place) to the target position. Set the decimal resolution in B007 before entering this parameter.

The Pre-Signal feature is used to turn ON an aux. output at a specified distance prior to the completion of a feed command. Typically, the Pre-Signal is used when anticipation of the end of a feed is needed, so other processes can be initiated ahead of time.

A pre-signal can be programmed for each axis. The Pre-signal applies to each feed command: POI, PSI, POA, POM, PSA, PSM.

After the initiation of the motion, if the Current Distance to travel is less than the Pre-signal Distance programmed in this parameter, the Pre-Signal output is switched ON. The Pre-Signal output will be ON for either the programmed period of time or until the next move (dependent on the parameter settings).

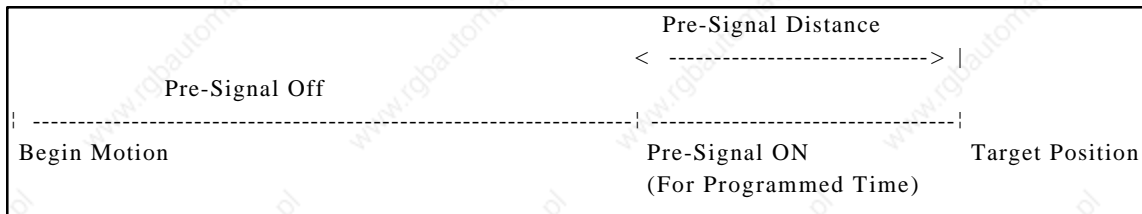

If the "Target Position" is equal to or less than the "Pre-Signal" distance, the Pre-Signal output is switched ON at the start of the feed motion for the specified amount of time.

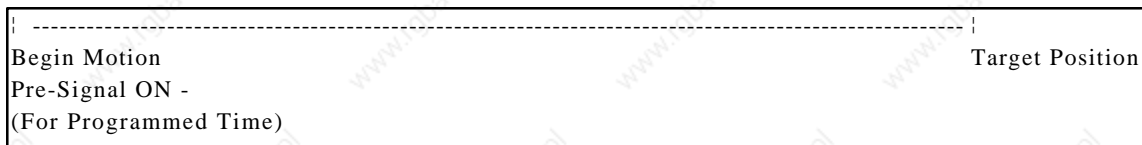

4.5.9 Parameter Ax08 - Feed Constant, Axis 1 - 4

Feed Constant Ax Ax08 00100000
--

- Minimum: 00001000
- Maximum: 50000000

This parameter sets the feed constant, which is the ratio of slide movement per encoder revolution.

The number entered equals the distance the axis will travel per one revolution of the encoder, to four or five decimal places. Set the decimal resolution in B007 before entering this parameter.

This parameter defines the input units used in other parameters.

ROTARY NOTE: Enter the amount of travel for one revolution of the table/device (one revolution of the gearbox output). The CLM will internally calculate the motor feed constant.

4.5.10 Parameter Ax09 - Direction of Operation, Axis 1 - 4

Direction	Ax
Ax09	01010000

This parameter allows changing the axis direction (+/-) by software in the CLM-A. It eliminates the need for wiring changes on direction and polarity.

- 00000000 = Direction of operation remains unchanged
- 01000000 = Reverse (switch) drive encoder
- 00010000 = Reverse (switch) analog polarity output
- 00000001 = Reverse (switch) absolute value encoder

Example:

- 01010000 = Reverse (switch) drive encoder and analog polarity output.

NOTE: If the command and the encoder are wired according to the interconnect diagram in [Appendix F](#), the first four digits should be either 0000 or 0101.

WARNING: Runaway conditions can occur if changes to these parameters result in incorrectly defined encoder/analog polarity in relation to the hardware. When these parameters are changed, it is recommended that the motor not be connected to the load until results are verified.

4.5.11 Parameter Ax10 - Homing, Incremental Encoder, Axis 1 - 4

(For homing with *Absolute* Encoder, see *next* page)

Homing Setup Ax
Ax10 00010500

This parameter specifies the search direction and speed for the zero reference point. See [section 3.2.5](#) for homing function description and [Appendix A](#) for additional application information.

- 00 - Search direction for home switch
 - 00 = Search Forward
 - 01 = Search Reverse
- 01 - Encoder type
 - 00 = No homing (disable homing function)
 - 01 = Homing using an incremental encoder
 - 02 = Homing using an absolute value encoder (*see next page*)
- 05 - Search velocity in % of max velocity
 - 01-99 = % of Ax00 in 1% increments (25% to 50% is normal for power up homing)
- 00 - Linear/rotary operation select
 - 00 = Standard operation
 - 01 = Rotary operation, with shortest path
 - 02 = Rotary operation, follows programmed direction, forward/reverse

The last digit of this parameter allows using the CLM for rotary table applications. If an incremental encoder is used with this function, homing is required because of the absolute measuring system. The rotary table option also must be activated by parameter (Ax16).

4.5.12 Parameter Ax10 - Homing, Absolute Encoder, Axis 1 - 4

(For Homing with *Incremental* Encoder, see *previous* page)

Homing Setup Ax
Ax10 00020000

When an absolute feedback device is used, this parameter specifies the search direction and speed for the zero reference point. See [section 3.2.5](#) for homing application information.

- 00 - Absolute Encoder Type
 - 00 = Standard 24 bit absolute encoder - Type AG 101
 - 12 = Single turn Absolute encoder, 12 bit, - Type AG 110
 - 21 = Special, 21 Bit Absolute encoder - Type AG100 512/4096
- 02 - Encoder type
 - 00 = No homing (homing function disabled)
 - 01 = Homing using an incremental encoder (*see previous page*)
 - 02 = Homing using an absolute value encoder (must be selected if absolute encoder is used for this axis)
- 00 - Unassigned
- 00 - Linear/Rotary Operation Select
 - 00 = Standard operation
 - 01 = Rotary operation, with shortest path
 - 02 = Rotary operation, follows programmed direction, forward/reverse

The last digit of this parameter allows using the CLM for rotary table applications. An absolute value encoder can be used with this function, however, the gear ratio must be an even power of 2. The rotary table option also must be activated by parameter (Ax16).

4.5.13 Parameter Ax11 - Homing Offset, Axis 1 - 4

Homing Offset Ax
Ax11 01234567

In many cases, some position other than the home position, such as the center-line of the slide, is used as the reference position. This parameter defines the distance (in input units), and the direction from the home switch that you want to use as the reference position.

This parameter is specified to two or three decimal places. Set the decimal resolution in B007 before entering this parameter.

For incremental encoder operation:

- 0 - Offset direction
 - 0 = Forward (+)
 - 1 = Reverse (-)
- 1234567 - Offset distance in input units, to 2 or 3 decimal places

For absolute value encoder operation:

- 0 - No significance
- 1234567 - Offset calculated from encoder reference point in input units, to 2 or 3 decimal places

For rotary applications, the zero offset may not exceed the value of input units / revolution of table. Otherwise, the error message "input error" will appear. For instance, if degrees have been selected as input units (360° / table revolution) and 10 has been programmed as the zero offset, the zero point is set at 10.

Refer to section 3.2.5 for additional information on the Homing function.

4.5.14 Parameter Ax12 - Homing Acknowledgement, Axis 1 - 4

Homing ACK	Ax
Ax12	09120013

This parameter is used to identify the various I/O assigned to the Homing Process. In Manual Mode, homing can take place by means of the assigned auxiliary input number, or in Automatic Mode by use of the command "HOM".

- 09 - Auxiliary input number used to initiate Homing in Manual Mode (push-button or PLC output)
 - 00 = Manual Mode homing not used
 - 01-16 = Selected input number to be used to initiate Homing
- 12 - Home Zero Reference Select (Marker Pulse or Home Switch)
 - 00 = Homing to Incremental Encoder Marker Pulse (Homing Speed for Homing to Marker Pulse is 3% of Max. Velocity)
 - 01-16 = Selected input number to be used for home switch input

NOTE: The standard CLM-01.3-A has a maximum of 24 auxiliary inputs that are physically accessible to the user. The CLM-01.3-A-E has expanded auxiliary input capability of 88 inputs.

- 00 - Unassigned
- 13 - Auxiliary output number to be used for "Home Established" signal

NOTE: The standard CLM-01-A has a maximum of 19 auxiliary outputs that are physically accessible to the user. The CLM-01-A-E has expanded auxiliary output capability of 51 outputs.

For absolute value encoder operation, Ax12 should be set to 00000000.

NOTE: The auxiliary output for Homing complete/established can be turned OFF with an AEA command (output ON/OFF). The travel limits will remain in effect (still referenced to home).

4.5.15 Parameter Ax13 - Travel Limit, Minimum Value, Axis 1 - 4

Min Travel	Ax
Ax13	-01234567

This parameter specifies the travel limit value in the negative direction, in reference to the Home Position. The limit is effective only after the axis has been Homed.

In the Manual Mode, the corresponding Jog key is disabled when this position has been reached. If, in the Automatic Mode, the commanded position is smaller (more negative) than this limit value, an error message will be displayed.

The travel limit value is measured from the reference point, Home Position, and is not added to, or subtracted from, the offset distance.

This parameter is specified in input units to two or three decimal places. Set the decimal resolution in B007 before entering this parameter.

For absolute value encoder operation:

A plus sign will appear for this parameter (instead of a minus sign) and the value here will be the minimum travel allowed. The travel limit value is measured from the zero point of the encoder and is not added to, or subtracted from, the offset distance.

4.5.16 Parameter Ax14 - Travel Limit, Maximum Value, Axis 1 - 4

Max Travel	Ax
Ax14	+01234567

This parameter specifies the travel limit value in the positive direction, in reference to the Home Position. The limit is effective only after the axis has been Homed.

In the Manual Mode, the corresponding Jog key is disabled when this position has been reached. If, in the automatic mode, the commanded position is greater than this limit value, an error message will be displayed.

The travel limit value is measured from the reference point, Home Position, and is not added to, or subtracted from, the offset distance.

This parameter is specified in input units to two or three decimal places. Set the decimal resolution in B007 before entering this parameter.

For absolute value encoder operation:

The travel limit value is measured from the zero point of the encoder and is not added to, or subtracted from, the offset distance.

4.5.17 Parameter Ax15 - Special Functions, Axis 1 - 4 (Position Loop Reset/Velocity Achieved/Master Encoder Averaging)

Special Funct	Ax
Ax15	12345678

- 12 - Acknowledgment input to reset the position loop (with 24v potential). The function will remain in effect until the input goes low again. Enter any number in the range of 01-24. Entering 00 here disables the function.
- 34 - Auxiliary output number (01-19) to indicate that the position loop is in a reset state.
- 56 - Aux. Output to indicate when the programmed velocity has been achieved.
- 7 - Not used - Enter 0
- 8 - Averaging of Master Encoder input pulse train for Master/Slave Mode (See FOL command).
 - 0 = No Averaging, No Feed Forward (1-9=Feed Forward Mode)
 - 1 = Average over 1 read
 - 2 = Average over 2 reads
 - 3 = Average over 4 reads
 - 4 = Average over 8 reads
 - 5 = Average over 16 reads
 - 6 = Average over 32 reads
 - 7 = Average over 64 reads
 - 8 = Average over 128 reads
 - 9 = Average over 256 reads

NOTE: 1 Read = 2 milliseconds (when using 1 or 2 axis, 2.4 ms for 3 axes, 2.8 ms for 4 axes). Feed forward automatically adjusts for following error between the axes, when averaging is selected. Any remaining following error can usually be minimized by slightly changing Ax21 RPM/10V (typical adjustment is less than 2%).

If no Special Functions are used, enter <00000000>.

This special function parameter is to reset position feedback and velocity command. It allows shifting of incremental position without causing an error (position fault). During this function, changes in the position feedback are ignored. Along with activating the reset function in the parameter, an auxiliary output number (not equal to 00) must be programmed to indicate the position loop reset state.

Notes about the Special Function - "Position Loop Reset"

With a potential of 24 volts at the acknowledgment input, Position Loop Reset takes place only if the axis is stopped; i.e., the motor is in position according to the position tolerance parameter set in Ax06.

CAUTION: While Position Loop Reset takes place, zero volts is output as the velocity command value. This may cause the drive to drift.

4.5.18 Parameter Ax16 - Rotary Axis Gear Ratio, Axis 1 - 4

Rotary Table Ax
Ax16 12345678

Use this parameter for Rotary applications.

This parameter sets the gear down ratio of the input motor shaft to the output. The rotary table option is activated in parameter Ax10.

- 1234 - Input motor shaft turns (gear box input-encoder)
- 5678 - Output turns (gear box output-table)

$$\text{Step down ratio} = \frac{1234}{5678}$$

The result per table revolution is:

$$\text{Input units / Revolution of table} = \text{Feed constant} \times \text{Step down ratio}$$

Examples:

00010001 = a 1:1 ratio (1 turn input, 1 turn output)

00120001 = a 12:1 ratio (12 turns input, 1 turn output)

02300025 = a 9.2:1 ratio (230 turns input, 25 turns output)

NOTE: Gear down only; entry must be whole numbers. If the ratio is decimal, simply enter the number of teeth on the input and output gear shafts.

4.5.19 Parameter Ax17 - Second Acceleration Rate, Axis 1 - 4

Knee Point	Ax
Ax17	12003860

- 12 - Velocity change point (in % of Velocity Max - Ax00) - Above this %, the second acceleration turns on - Knee point of acceleration change.
 - 00 = Disables this parameter
 - 01-99 = % in increments of 1%
- 003860 - Second acceleration - Input Units/second² (units/second/second) to zero or one decimal place, above the knee point velocity. Set the decimal resolution in B007 before entering this parameter.

The first acceleration below the knee point velocity is programmed in parameter Ax02.

This function is effective in Automatic operation as well as in Manual operation (for instance, jogging). The only limitation for the user programming is that the command ACC (change of acceleration) is not effective as long as this parameter is switched ON (can use one or other).

NOTE: Since the second acceleration may be greater than the first acceleration, the greater of the two values is to be considered the maximum acceleration.

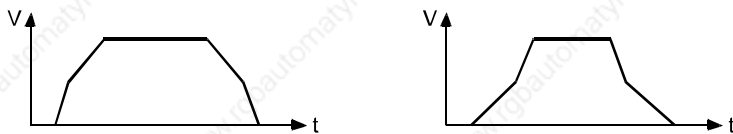

Figure 4-1 Examples of Attainable Velocity Profiles

4.5.20 Parameter Ax18 - Single/Dual Speed Motor Positioning (Max), Axis 1 - 4

Polum Max	Ax
Ax18	01234567

- 0 - Enable/Disable Option
 - 3 = function switched ON
 - 0 = function disabled
- 1234567 - Braking distance from Vmax to Vmin (fast to slow), in input units to 2 or 3 places. Set the decimal resolution in B007 before entering this parameter.

You can use this function to control motors with speed and reversing contactors with absolute value encoders.

NOTE: This function is currently not supported. Consult an Indramat Application Engineer for additional information.

NOTE: See Parameter Ax19 for further description of function.

- Ax18 is Decel mode, Vmax to Vmin,
- Ax19 is Decel mode, Vmin to Stop.

4.5.21 Parameter Ax19 - Single/Dual Speed Motor Positioning (Min), Axis 1 - 4

Polum	Min	Ax
Ax19	00	123456

- 00 - Number of the first output

Auxiliary outputs:

- xx high speed
- xx+1 low speed
- xx+2 left travel
- xx+3 right travel
- xx+4 motor ON
- 123456 - Braking distance from Vmin to stop, in input units to 2 or 3 places. Set the decimal resolution in B007 before entering this parameter.

NOTE: This function works in accordance with, and is enabled in, Ax18.

You can use this function to control motors with speed and reversing contactors with absolute value encoders. The analog output is no longer used while this is done.

The motor is controlled by 5 fixed outputs that are defined for each axis. Depending on the function, the outputs are processed simultaneously by the CLM.

Possible contact overlaps, due to differing energizing or de-energizing times of the relays, must be compensated for externally.

Commands that can be used:

- POA
- PSA
- POI
- PSI
- CON - traverse with "slow" only

Inputs that can be used:

- Jog - traverse with "slow" only
- Feed Interrupt Function of Ax20.
- Cycle Stop

4.5.22 Parameter Ax20 - Feed Angle Monitoring, Feed Interrupt, Axis 1 - 4

Feed Angle MonAx
Ax20 01020000

- 01 - Aux. input number for Feed Angle Monitoring with error display, Axis X
 - 00 = Feed Angle Monitoring Axis 1 not used
- 02 - Aux. input number for Feed Interrupt, Axis X (Feed Hold)
 - 00 = Feed Interrupt Axis X not used
- 00 - Not Used
- 00 - Output: "Deceleration of the commanded position active"
 - 00 = Function disabled

NOTE: There are no diagnostics for Feed Angle input missing before a feed or when a Feed Interrupt is executed.

01 - Feed Angle Monitoring (Active High)

This parameter specifies if the feed is to be monitored or not. If "00" is input here, the corresponding axis is not monitored. If an auxiliary input number has been specified and if there is no signal at the specified input, no feed will take place. The CLM processes all blocks not containing any feed lengths. As soon as the program processing comes to a block containing a feed length, the CLM will stop in this block until there is a signal at the input. If the specified auxiliary input signal shuts off during a feed, the feed will be stopped and an error message will be displayed.

02 - Feed Interrupt or Feed Hold (Active Low)

This parameter specifies whether an interruption of the programmed feed in process is possible or not. If "00" is input here, there will be no monitoring for interruption. If an input number is assigned, and an interrupt is present, those feed movements that have not been initiated will not be executed. The CLM will continue to process all blocks not containing any feed lengths, regardless of how Ax20 is set. As soon as the program processing comes to a block containing a feed length, the CLM will stop in this block until there is a signal at the input. If the specified auxiliary input shuts off during a feed, the feed will be stopped.

WARNING: The continuation of the feed will occur immediately as the auxiliary input, Feed Interrupt returns high.

NOTE: If feed angle monitoring has been specified for an axis, the Feed Interrupt input number must be different for that axis (the two functions cannot be used together for the same axis with the same input number).

4.5.23 Parameter Ax21 - Drive Input Sensitivity, Axis 1 - 4

Drv Input Sen Ax Ax21 20000100
--

- 2000 - Maximum motor RPM (0001 to 9999) at specified input voltage
- 0100 - Input voltage at maximum motor RPM
 - One decimal place precision, i.e. 0100= 10.0 V. (000.5 to 010.0)

This parameter defines the sensitivity of the motor (RPM) to the drive input voltage. The voltage range input can vary from 1.0 volts to 10.0 volts. Typically, the user enters the maximum RPM at 10 volts.

Enter the input sensitivity rating shown on the amplifier personality module for E1/E2.

Example: A121 entry for 1500 RPM/10 V is:

Drv Input Sen A1 A121 15000100
--

4.5.24 Parameter Ax22 - Monitor Window, Axis 1 - 4

Monitor Wind. Ax	
Ax22	00000010

- 0 - Error Messages
 - 0= Error Messages active
 - 8= Error Messages deactivated
- 0 - Unassigned
- 00 - Output for Positioning Error greater than maximum permissible deviation.

NOTE: The output programmed here is only set if the error messages have been deactivated, by entering "8" in the first screen position of this parameter.

- 0 - Unassigned
- 010 - Maximum position deviation error, in percent of the maximum position deviation.
Entry limits: 001-100. A typical entry here is 010-020, for 10-20%.

The CLM continuously monitors all enabled axes for "Drive Runaway" and blockage of the axis(es), "Excessive Pos Lag". The CLM uses a mathematical model of the system to calculate the "normal" following error expected. "Drive Runaway" and "Excessive Pos Lag" cause the corresponding error message to appear. Drive runaway occurs if the actual position of the encoder exceeds the expected position calculated with the model. The axis is considered blocked if the actual position of the encoder is less than the position expected by the model.

Program the maximum permissible deviation (in percentage) between the actual position and the position calculated by the model, in this parameter. For the monitoring to function properly, program a value in this parameter greater than the percentage of deviation that results under normal operation. Otherwise, nuisance faults will occur.

Calculate the maximum Following Error:

$$\text{Max. Following Error} = \frac{\text{Max. Velocity (IU/sec)}}{\text{Position Gain (KV)}} \times \frac{60}{1000}$$

Example:

If Max. Velocity = 0005000 (50 inches/second) and Position Gain = 00000400 (4 inches/minute/mil), the calculated following error at maximum speed would be:

$$\text{FE} = \frac{50 \text{ in}}{1 \text{ sec}} \times \frac{60 \text{ sec}}{1 \text{ min}} \times \frac{1}{\text{KV} \times 1000} = 0.75 \text{ in}$$

If $Ax22 = 00000005$, the CLM will issue an error if the actual following error differs from the expected following error by more than 5%. Take 5% of 0.750 inches: $0.05 \times 0.750 = 0.0375$. When feeding at maximum velocity, the LS display screen (following error) would read about 0.750 inches.

An "E.P.L." error would occur if the following error exceeded $0.750 + 0.0375 = 0.788$ inches. A "D.R." error would occur if the following error went below $0.750 - 0.0375 = 0.712$ inches. When feeding at a lower velocity, the following error will be lower, but the maximum deviation from the expected following error will still be ± 0.0375 inches.

Note the following:

If you change the parameters Position Gain or Maximum Velocity, you do not need to reprogram the Monitor Window, because it is entered in percentage of maximum position deviation.

If the Monitor Window entry, as converted, is smaller than the Position Tolerance, the CLM is unable to correctly distinguish between "Drive Runaway" and "Excessive Position Lag." Therefore, the converted Monitor Window parameter should be greater than the Position Tolerance.

If the programmed entry for Monitor Window is too small, even a normal feed will generate a "Drive Runaway" or "Excessive Position Lag" error.

The Monitor Window value depends on your application. You should enter the lowest percentage possible that will not cause nuisance faults.

Possible causes for "Drive Runaway"

- The parameter "Direction of Operation" is incompatible with the wiring of the encoder or with the command inputs E1/E2/E3/E4.
- The axis moved when no command value has been output.
- $Ax04$ does not correspond to the actual encoder data (too small).
- The maximum RPM in $Ax21$ is smaller than specified on the amplifier personality module.
- $Ax22$ entry is too small (*typical setting is 10%*).

Possible causes for "Excess Position Lag"

- Feed command issued, but no movement detected:
 - the encoder cable is not connected,
 - the encoder cable or encoder is defective,
 - the motor cannot turn because of a mechanical bind.
- $Ax04$ does not correspond to the actual encoder data (too large).
- The maximum RPM in $Ax21$ is greater than specified on the amplifier personality module.
- The acceleration is too great ($Ax02$, also $Ax17$ second acceleration).
- The CLM signal controller enable is not reaching the drive.

- The CLM velocity command is not reaching the drive.
- Ax22 entry is too small (typical setting is 10%).

4.5.25 Parameter Ax23 - Follow / Synchronous / Measuring Wheel

Follow-/Sync.-Ax
Ax23 13001234

- 1 = Mode
 - 0 = Normal Feed Axis
 - 1 = Synchronous Axis
 - 2 = Following Axis
 - 3 = Meas. Wheel Version 1 (Regular Measuring Wheel)
 - 4 = Meas. Wheel Version 2 (Meas Wheel with Feed Correction)
- 3 = If Synchronous Mode selected
 - 1 = Axis X synchronized with Axis 1
 - 3 = Axis X synchronized with Axis 3

If Following Mode selected

- 1 = Axis X follows Axis 1
- 3 = Axis X follows Axis 3
- 5 = Axis X follows Measuring Wheel
- 00 = Not Used
- 12 = Percent deviation allowed (00-99) between Measuring Wheel encoder and axis encoder
- 34 = Measuring Wheel Mode
 - 00 = Measuring Wheel Not Active
 - 01-99 = Input used to activate the Measuring Wheel

The Following Modes available are:

	(A123)
Axis 1: Normal Feed Axis	00000000
Following Mode, Axis 1 follows Meas. Wheel	25000000
Measuring Wheel, Version 1	35000000
Measuring Wheel, Version 2	45000000

	(A223)
Axis 2: Normal Feed Axis	00000000
Synch. Mode, Axis 2 synchronized with Axis	111000000
Following Mode, Axis 2 follows Axis 1	21000000
Following Mode, Axis 2 follows Meas. Wheel	25000000

(A323)
Axis 3:Normal Feed Axis 00000000
Synch Mode, Axis 3 synchronized with Axis 1 11000000
Following Mode, Axis 3 follows Axis 1 21000000
Following Mode, Axis 3 follows Meas. Wheel 25000000

(A423)
Axis 4:Normal Feed Axis 00000000
Synch. Mode, Axis 4 synchronized with Axis 1 110000000
Synch. Mode, Axis 4 synchronized with Axis 3 130000000
Following Mode, Axis 4 follows Axis 1 21000000
Following Mode, Axis 4 follows Axis 3 23000000
Following Mode, Axis4 follows Meas. Wheel 25000000

4.5.26 Parameter Ax24 - Delay Axis x

(as of software version LA01.3-3.0)

Delay Ax
Ax24
0000000.0

Delay Ax
Ax24
00000000

- 00000000 - Maximum delay in EGE/s
- or
- 0000000.0 - Additional programming for the delay can be done using the DEC command (in % of maximum amount in Ax24)
 - Range: As in Parameter Ax02

4.5.27 Parameter Ax25 - Jerk constant

(as of software version CLM1.3-LA1-04V07)

Jerk constant Ax	
Ax25	
0000	0.000

- 0000 - Not used, set to 0000
- 0.000 - Time constant for acceleration change (in s)
 - Range: 0.000 to 1.024
 - 0 = Constant acceleration

The “acceleration time constant” indicates the time during which the CLM accelerates. Internally, the CLM rounds up the time constant according to the following equation:

$$\frac{\text{Jerk constant (s)} \times 1000}{\text{Position control cycle time (ms)}} = 2^n$$

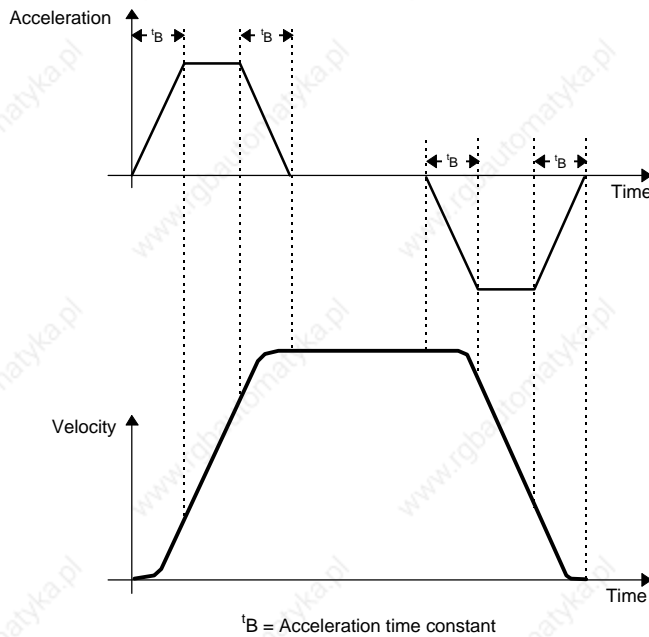

Figure 4-2 Jerk limit

4.5.28 Parameter B000 - Enable Axis 2

Enable Axis 2
B000 10000000

- 1 - Axis Enable/Disable
 - 0 = Axis 2 is disabled
 - 1 = Axis 2 is enabled
- 0000000 - Not used, must be set to 0000000

This parameter allows enabling axis 2. Note that axis 1 is always enabled. The CLM will control axis 1, 2, 3 and/or 4, as enabled in these "B" parameters.

With axis 2 enabled, values must be entered into parameters A200-A222. If the axis is enabled without entering the necessary values for parameters A200-A222, an error condition occurs and the message "Is Invalid" appears.

4.5.29 Parameter B001 - Enable Axis 3

Enable Axis 3
B001 10000000

- 1 - Axis Enable/Disable
 - 0 = Axis 3 is disabled
 - 1 = Axis 3 is enabled
- 0000000 - Not used, must be set to 00000000

This parameter allows enabling axis 3. Note that axis 1 is always enabled. The CLM will control axis 1, 2, 3 and/or 4, as enabled in these "B" parameters. If the axis is enabled without entering the necessary values for parameters A300-A322, an error condition occurs and the message "Is Invalid" appears.

4.5.30 Parameter B002 - Enable Axis 4

Enable Axis 4	
B002	10000000

- 1 - Axis Enable/Disable
 - 0 = Axis 4 is disabled
 - 1 = Axis 4 is enabled
- 0000000 - Not used, must be set to 0000000

This parameter allows enabling axis 4. Note that axis 1 is always enabled. The CLM will control axis 1, 2, 3 and/or 4, as enabled in these "B" parameters.

With axis 4 enabled, values must be entered into parameters A400-A422. If the axis is enabled without entering the necessary values, an error condition occurs and the message "Is Invalid" appears.

4.5.31 Parameter B003 - Serial Interface Information

Serial Interface B003 09600181
--

The serial interface of the CLM can exchange data with peripherals in various ways. Define the transmission method in this parameter. Chapter 7 describes the interface in more detail.

- 0960 - Baud Rate
 - Min.= 110 Baud
 - Max.=19200 Baud
- 0000 = Interface not operating (to host computer)

Baud Rate input examples using common rates:

1920 - 19200 Baud, 0960 - 9600 Baud, 0480 - 4800 Baud, 0240 - 2400 Baud

- 0 - Interface Mode
 - 0 = Standard RS232/RS422 (full duplex)
 - 1 = IDS, decade switch, option
 - 2 = Same as Mode 0
 - 3 = Serial port for SOT (Indramat Station Operator Terminal); RS232/RS422, half duplex, one station only
 - 4 = Serial bus link for SOT; RS485, half duplex, station 1 through 15

NOTE: If you select the IDS option, do not enter the other values for this parameter. The CLM will configure the interface automatically.

- 1 - Parity
 - 1 = No parity
 - 2 = Even parity
 - 3 = Odd parity
- 8 - Word Length
 - 7 = 7 Bits
 - 8 = 8 Bits
- 1 - Number of Stop Bits
 - 1 = 1 Bit
 - 2 = 2 Bits

4.5.32 Parameter B004 - Serial Interface Information

Serial Interface
B004 11089000

- 1 - Checksum/Hardware Handshake (RTS/CTS)
 - 0 = Checksum ON, RTS/CTS OFF
 - 1 = Checksum OFF, RTS/CTS OFF
 - 2 = Checksum ON, RTS/CTS ON
 - 3 = Checksum OFF, RTS/CTS ON
- 1 - Transmission Acknowledgment - " Y CR/LF "
 - 0 = Acknowledgment OFF
 - 1 = Acknowledgment ON
- 08 - Station Number, 01-15
Used with serial bus for SOT communication (See Parameter B003: Serial Interface - Interface Mode description)
- 9 - Error Code Over Serial Interface
 - 0 = Function Disabled
 - 1 = In case of CLM fault, automatically send an error message via the serial interface. See Status 53 in chapter 7 for details.
- 0 = Not used
- 00 - Send Delay Time During RS-485 Operation
 - 00 = no delay

This parameter allows the integration of the calculation of the check sum into the interface. The CLM will perform a bit count comparison from one operation (processing).

If a "0" is not programmed in the first bit, a check sum is not required for communication, i.e. instead of "Checksum CR/LF", a "_CR/LF" is sufficient.

If it is important that the data sent to the CLM is received correctly, it is recommended that the checksum be turned ON. The host device must be programmed to calculate and send the checksum with each transmission to use this option.

Transmission Acknowledgment, when active, returns a "Y" "CR/LF" from the CLM to the Host Device. This occurs after any command transmitted to the CLM that does not require any other response from the CLM.

4.5.33 Parameter B005 - Memory Display

NOTE: For service use only!

Memory Display

B005

53 FF02F8

- 53 - Memory Display on/off
 - 53 = Memory Display on
 - 00 = Memory Display off
- FF02F8 - Address

When the Memory Display is turned on, the contents of the RAM can be shown on the screen. The memory in Parameter B005 is the default address that appears on the display when the CLM-01 is turned on or after a fault.

During operation, the address can be changed by directly overwriting the text. Using the + and - keys allows scrolling through the addresses byte-by-byte. The letters A through F can be composed by pressing the following key combinations:

◇ and "1" = A ◇ and "2" = B ◇ and "3" = C
◇ and "4" = D ◇ and "5" = E ◇ and "6" = F

4.5.34 Parameter B006 - Start Task 2 & 3

Start Task 2 & 3 B006 02010301
--

- 0201 - Starting block number for second task
 - 0001-2999 = Any Block number except 0000 or a block number of another task
 - 0000 = Task 2 program disabled
- 0301 - Starting block number for third task
 - 0001-2999 = Any block number except 0000 or a block number of another task
 - 0000 = Task 3 program disabled

Task 1 always starts at block number 0000.

This parameter allows running separate sub-routines of the program at the same time.

As soon as the CLM is switched to Manual or Automatic mode, Task 3 begins running.

As soon as Cycle Start actuated, in Auto Mode, Task 1 and 2 start running.

NOTE: Do not access the same routine by two tasks at the same time (within 2 milliseconds) or a system fault will occur. The user program must be in place for task 3 before leaving the parameter mode because task 3 will start running immediately.

WARNING: Do not use task 3 for servo commands. Task 3 continues running in Manual Mode and during an E-Stop.

4.5.35 Parameter B007 - Display Language / Decimal Place / Keypad Lockout

Language	
B007	01030045

Use this parameter to specify in which language text will display on the CLM control panel and to set the number of decimal places used in positioning commands and certain parameters. It also allows disabling any program entry/changes from the CLM keypad.

- 01 - Language
 - 00 = German
 - 01 = English
 - 02 = French
 - 03 = Spanish
 - 04 = Italian
 - 05 = Portuguese
- 03 - Number of decimal places used in positioning commands and certain parameters
 - 02 = Metric (e. g., millimeters, XXX.YY)
 - 03 = US System (e. g., inches, XX.YYY)

The number entered for decimal places specifies how many digits are to the right of the decimal point for positioning commands and many parameters. Make your selection depending on the resolution required. See Appendix E, parameter input sheets, showing the decimal location for each parameter, with resolution set at 2 or 3 in B007.

Parameter # affected:	4th digit of B007	
	= 2	= 3
Ax02, Ax07, Ax17	0	1
Ax00, Ax01, Ax06, Ax11, Ax13, Ax14, Ax18, Ax19	2	3
Ax08, B018	4	5
Command affected:	4th digit of B007	
	= 2	= 3
POI, PSI, POA, PSA, PSM, PST, VCA, VCC, BPT, BZP	2	3
REP	0	1

- 0 - Unassigned, set to zero
- 0 - Enable "fault code via outputs"
 - 0 = No fault code via outputs
 - 1 = Fault code via outputs, 01 to 08
 - 2 = Fault code via outputs, 09 to 16
 - 3 = Fault code via outputs, 17 to 24
 - 4 = Fault code via outputs, 25 to 32
 - 5 = Fault code via outputs, 33 to 40
 - 6 = Fault code via outputs, 41 to 48

If the function is enabled, an appropriate fault code is outputted via the programmed output when there is a fault. The fault code consists of 2 hex digits.

Fault code assignment:	00 to 3F -	General disturbance
	40 to 6F -	Disturbance axis 1
	70 to 9F -	Disturbance axis 2
	A0 to CF -	Disturbance axis 3
	D0 to FF -	Disturbance Axis 4

Example: Parameter B007 = xxxxx3xx

Error = Excessive Position Lag

Output # 24 23 22 21 20 19 18 17

Weight 2³ 2² 2¹ 2⁰ 2³ 2² 2¹ 2⁰

0 1 1 1 0 0 1 1

7 3 Hex Code is 73

For a complete list of fault codes and explanations, see chapter 8, Diagnostics and Troubleshooting.

- 45 - Lock out feature
 - 45 = Inhibits storage in memory of program blocks which are entered via the CLM keypad.
 - 55 = Allows changes in data, but not in data structure (as of software version 04V07).

NOTE: Programming can still be accomplished via the RS232 interface, such as by downloading from MotionManager program assembler. The lock out feature prevents accidental or unauthorized changes.

4.5.36 Parameter B008 - Variations

Variations B008 00001000

- 0000 - Not Used
- 1 -Position of Axis 1 that is used to turn on expansion outputs
 - 0 = Disabled
 - 1 = Enabled
- 0 - Position of Axis 2 that is used to turn on expansion outputs
 - 0 = Disabled
 - 1 = Enabled
- 00 - Number of scanned blocks per block cycle in Task 3.

4.5.37 Parameter B009 - Start Program Block - Task 4, Task 5

Start Task 4 & 5

B009
0000 0000

- 0000 - Task 4 Start
– 0000 = Task 4 off
- 0000 - Task 5 Start
– 0000 = Task 5 off

Task 4 and 5 behave like Task 2. For further information, see Section 5.3 Multi-tasking.

4.5.38 Parameter B010 - Clear Outputs

(as of software version LA01.3-3.0)

Clear outputs

B010
00000000

- 0 - Outputs 01 to 08
- 0 - Outputs 09 to 16
- 0 - Outputs 17 to 24
- 0 - Outputs 25 to 32
- 0 - Outputs 33 to 40
- 0 - Outputs 41 to 48
- 0 - Outputs 49 to 56
- 0 - Outputs 57 to 64

This function enables clearing of outputs when faults occur. For each group of 8 outputs, the following inputs are possible:

- 0 = Clear outputs when a fault or E-STOP occurs.
- 1 = Do not clear outputs when a fault or E-STOP occurs. Outputs are cleared when the fault is cleared.
- 2 = Do not clear outputs when a fault or E-STOP occurs or is cleared (clear key or external clear).

If “00000000” is entered for Parameter B010, the outputs have the same characteristics as in previous revisions of the software (e.g. software version LA 01.3-02.9 or previous).

4.5.39 Parameter B011 - Manual Vector

Manual - Vector
B011 07101678

- 07 - Aux. input number to initiate Manual Vector program start with rising signal edge
 - 00 = Manual Vector Disabled
 - 01-16 = Aux. Input Number
- 1 - 0 = Start Manual Vector program only when in Manual Mode and manual vector input goes high
 - 1 = Jump to the Manual Vector program when switching from Automatic to Manual Mode (Automatic input goes Off), or when in Manual Mode and Manual Vector input goes High
- 0 - Not used, set to 0
- 1678 - Start block of Manual Vector program, Block 0000-2999.

NOTE: You must use Command RTS, Return from Sub-routine, to terminate the Manual Vector program.

This function allows you to run a user program in Manual Mode. This program must conclude with an "RTS" (the sub-routine stack will not be changed). This program may not contain any feed instructions. The program is aborted if there is a switch over from "Manual" to "Automatic" or to "Parameter Mode." The program is started externally by means of a rising signal edge at one of the aux. inputs. If "00" is input for the aux. input, the Manual Vector is disabled. When programming Parameter B011, make sure that the start block of the Manual Vector program is not located in the main program.

NOTES:

- The manual vector input is not accepted during jogging or homing (in the manual mode). Hom-ing is possible in the manual program by using the HOM command, but this should be avoided.
- While the manual vector program is running, jogging or homing is not possible.
- It is not possible to start the program unless all enabled axes drive ready inputs have 24 volt potential.

Example:

Manual	-	Vector
B011		13100400

0400 APE 0 0200000000
0401 APE 1 1000222222
0402 RTS

4.5.40 Parameter B012 - Program Interrupt Vector

(for Task 1 only)

Interrupt Vector B012 08122678
--

Immediate interruption of main program, start Interrupt Vector program. Can be used as an "Emergency Return" procedure.

- 08
 - 00 = Disables Interrupt Vector
 - 01-16 = Aux. input number used to initiate Interrupt Vector program on rising edge of signal
- 1
 - 0 = The vector is disable while a subroutine (JSR) is running (rising edge)
 - 1 = The vector is always active (rising edge)
 - 2 = The vector is disabled while a subroutine (JSR) is running (falling edge)
 - 3 = The vectore is always active (falling edge)
- 2
 - 0 = A started feed will finish before executing the Interrupt Vector program
 - 1 = Feed is interrupted (drive(s) braked until stopped) and execute the Interrupt Vector program
- 2678 - Start block of Interrupt Vector program, Block 0000-2999

The Interrupt Vector permits you to interrupt a user program externally at any time. The program sequence will then continue at the start block number specified for the Interrupt Vector program. No RTS command is required at the end of the Interrupt Vector Program. There is no return jump to the interrupted main program.

NOTE: When a main program is interrupted, it cannot be resumed. It must be started over.

The Interrupt Vector can be called up only in Automatic operation. The "Cycle Start" and **"Error! Reference source not found."** remain effective.

The sub-program stack (JSR, RTS) is always cleared any time the Interrupt Vector program is called up.

A call to the Interrupt Vector while a sub-program is running, "xx0xxxxx" is stored in B012 until all sub-programs have been processed. Only then will the program continue with the "Interrupt Vector" program address.

4.5.41 Parameter B013 - Analog Input

Analog Input	
B013	00000308

- 0 - Override axis 1
- 0 - Override axis 2
- 0 - Override axis 3
- 0 - Override axis 4

For each of the four axes listed above:

- 0 = override off
- 1 = override through analog input 1
- 2 = override through analog input 2
- 3 = override through analog input 3
- 4 = override through analog input 4
- 5 = override binary-encoded through inputs 09-16
- 6 = override gray-encoded through inputs 13-16

NOTE: If Gray Code Override is selected for axis 1-4, the auxiliary inputs 13-16 are used for all axes. Each axis is overridden by the same amount. See the table on the following page.

- 0 -
 - <>9 = minimum velocity limited to 5%
 - 9 = minimum velocity is 0 when 0V present at the analog input (as of software version 03V07)
- 3 - Digit value corresponding to an update time, in milliseconds, for analog averaging.

Digit Value	Update/ms	Analog Value
0	4 ms	1
1	2 ms	8
2	4 ms	16
3	28 ms	32
4	56 ms	64
5	12 ms	128
6	024 ms	256
7	048 ms	512
8	096 ms	1024
9	192 ms	2048

- 08 - Analog Averaging Enable
 - 00 = Analog Averaging is always enabled
 - 01-16 = Aux. input for enabling Analog Averaging.

This parameter is used to select the averaging of the analog input values for the Analog Inputs: AE1, AE2, AE3 and AE4). These inputs are received via the CLM's connections X5 and X7. By selecting a value from 0 to 9, one can average the analog value that will be used by the CLM over the course of 1 to 2048 reads of the analog input. When selecting a higher value, the filtering and damping effect will be increased.

NOTE: 1 read= 2 milliseconds with 1 or 2 axes enabled, 2.4 ms with 3 axes, 2.8 ms with 4 axes. Read times can also be set (increased) in parameter B015.

If the aux. input number is set to 00, Analog Averaging is always enabled. If an aux. input is used, Analog Averaging is enabled when the input is ON (+24 Vdc). If the aux. input is OFF (0 Vdc), the analog value is updated every 4 milliseconds.

Gray Code Override - The following input assignments result in the noted speed. Note the velocity in the right column, enter the respective number on that line for the input number (top line).

Input Number	13	14	15	16	
Significance of Acknowledgment	2^0	2^1	2^2	2^3	Velocity in %
	0	0	0	0	0
	1	0	0	0	1
	1	1	0	0	2
	0	1	0	0	4
	0	1	1	0	6
	1	1	1	0	8
	1	0	1	0	10
	0	0	1	0	20
	0	0	1	1	30
	1	0	1	1	40
	1	1	1	1	50
	0	1	1	1	60
	0	1	0	1	70
	1	1	0	1	80
	1	0	0	1	90
	0	0	0	1	100

4.5.42 Parameter B014 - Restart Vector

Re-Start Vector	
B014	00001234

- 0000 - Unused, set to 0000
- 1234 - Starting block for the Restart Vector program.

NOTES:

- If B014 is programmed with all zeros, Restart Vector is not active.
- *Use this parameter only if the system is equipped with an absolute encoder.*

This parameter is used to define the starting block for the Restart Vector routine. If a program is interrupted by a power loss, system error or mode change, the status of outputs, absolute target position and velocity are temporarily stored in memory.

Based on the type of error and system configuration, it may be possible to restore the status of the CLM as before the interrupt. This is indicated by System Output 09: ON - Restart possible; OFF - Restart Not possible.

The Restart Vector routine is initiated by a momentary pulse, OFF to ON (0V to +24V), at System Input 15.

NOTE: The temporarily stored absolute target position will only be resume if the corresponding axis is equipped with an absolute encoder.

4.5.43 Parameter B015 - Cycle Time

Cycle Time
B015 12000000

This parameter allows changing the default cycle time to match a PLC or other external machine device. The default cycle time depends on the number of axes enabled (B000, B001, B002).

- 12 - Program block cycle time
 - 00 = Default cycle time (depends on the number of axes enabled, as listed below):
 - 2.0 milliseconds for 1 or 2 axes enabled
 - 3.0 milliseconds for 3 axes enabled
 - 4.0 milliseconds for 4 axes enabled
 - 20 = 2.0 milliseconds per interrupt cycle
 - 25 = 2.5 milliseconds per interrupt cycle
 - 30 = 3.0 milliseconds per interrupt cycle
 - 35 = 3.5 milliseconds per interrupt cycle
 - 40 = 4.0 milliseconds per interrupt cycle
- 000000 - Not used, must be set to 000000

4.5.44 Parameter B016 - Measuring Wheel Encoder

Measure Encoder1
B016 50100000

- 5 - Encoder type, for Measuring Wheel
 - 5 = Incremental
- 0 - Not Used
- 1 - Direction of Operation
 - 0 = No change
 - 1 = Change direction
- 0000 - Not Used

4.5.45 Parameter B017 - Measuring Wheel Encoder, Lines/Revolution

ME1	Lines/Rev
B017	00005000

- 0000 - Not Used
- 5000 - Encoder lines per revolution
 - Min. = 100
 - Max. = 5000

4.5.46 Parameter B018 - Measuring Wheel Feed Constant

ME1	Feed Const.
B018	05000000

- 05000000 - Feed Constant

To 4 or 5 decimal places, depending on value entered in Parameter B007.

- Minimum value = 0.1000
- Maximum value = 1000.000

4.5.47 Parameter B019 - Measuring Wheel Offset

ME1	Offset
B019	00000000

This parameter is currently under development. Contact Indramat Engineering for further information.

5. PROGRAMMING

The application program of the system is defined and entered by the user. It can be entered directly via the CLM-01.3-A keyboard, or from a remote terminal device interfaced through the RS-232, RS-422, or RS-485 port. The application program flow is similar to a Basic program. Three letter mnemonic commands are used. There are 3000 programming lines/blocks available for user programming, numbered 0000 through 2999.

The Indramat MotionManager™ Program Assembler provides an efficient method of creating and editing the user program for the CLM control. It is a software package that runs on any DOS-based computer. It provides several benefits over programming the CLM from its control panel. It also includes enhanced features for creating and editing program that are not possible from the CLM control panel. Refer to Publication IA 74733 for specific information on using this software program.

This chapter begins by describing some basic information that should be considered before creating a program for the CLM. It then describes the methods to enter the user program directly into the CLM control panel. It further describes the programming commands and their function in a user program.

5.1 Positioning

Two types of positioning can be selected in the system, absolute and incremental. All positioning is done in the units of your choice and are referred to as **Input Units (IU)**. Input Units are the user's desired units of measure (i.e. inches, mm, radians, degrees, etc.).

In absolute positioning, all movements of the slide are made some absolute distance from the machine reference point. Thus, if the slide is at +2 inches from home, and an absolute position command to move +3 inches is executed, a one inch feed in the positive direction will result.

In incremental positioning, all movements of the slide are made in the commanded direction to the distance specified, starting from the current position. Thus, if a slide is at +2 inches from home, an incremental command to move +3 inches will result in the slide being positioned +5 inches from home.

5.2 Auxiliary Inputs/Outputs

The CLM has a set of I/O points with a predefined use. It also includes a set of I/O points which can be defined by the user for controlling machine functions. They will be referred to as auxiliary inputs and auxiliary outputs (or aux. inputs and aux. outputs). Auxiliary inputs are also known as acknowledgments. Certain commands are provided for use to address these inputs and outputs. The I/O Commands are described in section 5.8.5.

WARNING: Auxiliary input and output numbers that have been dedicated by the machine builder for a specific purpose must not be changed. Personal injury or damage to the machine/drive train could result from such changes.

5.2.1 Programming Inputs/Outputs

Certain outputs are predefined in the CLM internal program and cannot be changed by the user program. When the CLM is powered ON, it sets certain outputs, per the internal program, to default position. Likewise, when a fault occurs, it sets many outputs OFF. Outputs are re-established, either through hardware or software, i.e. the Automatic Mode Indicator turns ON after that mode is selected by input (assuming all other conditions are met), a software flag is turned ON or OFF as the user program executes the block containing the command.

Chapter 2 describes the functional use of each system input/output, as well as many programming and parameter entries specifying input or output connections. Several I/O are available for use as flags in the user program. Certain output flags are set in firmware and can be queried by the user program. Table 5.1 list the hardware outputs that can be used in program to electrically control an external component. It also lists the output software flags that can be used internally in the program. It defines the output flags which are set in firmware. Refer to this table when programming an output. Also refer to Table 2.1 in Chapter 2 which lists all inputs and outputs, along with hardware connections.

5.2.2 Inputs/Outputs Signal Definition

There are two states that system inputs/outputs and auxiliary inputs/outputs could hold. The "ON" or High state, means that there is a +24 Vdc signal present at the input/output. The "OFF" or Low state, means that there is a 0 Vdc signal at the input/output. A signal line is described as "Active High" when its associated action is initiated by a High (+24 volts) signal level. It is described as "Active Low" when its function is initiated by a Low signal (0 volts). An active low signal must remain in the high state to allow normal operation. If it goes low, the CLM initiates the actions required for an Emergency Stop condition. Refer to Chapter 3 for further description of I/O signals.

Table 5-1 Output Definitions

Standard CLM	19	Hardware Outputs	1-19
	80	Software Flags	20-99
Expanded CLM	51	Hardware Outputs	1-51
	48	Software Flags	52-99
Outputs and Flags	1 to 72	will be cleared (set to 0 volts) when: 1) the CLM is first powered-up or if there is a loss of power 2) there is a system fault (hardware or program)	
Output Flags	73 to 80	are cleared when: 1) the CLM is first powered-up or there is a loss of power 2) an E-Stop error occurs, or the CLM is switched to Parameter Mode	
Output Flags	81 to 88	are retained in RAM (battery backed), they can only be cleared: 1) if they are turned ON/OFF in the user program 2) if the battery is disconnected or fails	
Output Flags	89 to 94	are set in firmware and can be queried by the user program	
	89	“1”	indicates Manual Mode
	90	“1”	indicates Automatic Mode
	91		currently not used
	92		currently not used
	93		currently not used
	94	“0”	indicates a system fault
Output Flags	95 to 99	are set within the user program to provide specific actions; they are cleared when the CLM is first powered up or loses power	
	95	“x”	Monitoring Window, Axis 1 is turned: OFF =1 or ON =0 (see Warning below)
	96	“x”	Monitoring Window, Axis 2, is turned: OFF =1 or ON =0 (see Warning below)
	97		currently not used
	98	“1”	Axis 1 motion is interrupted (see Warning below)
	99	“1”	Axis 2 motion is interrupted (see Warning below)

WARNING: If the Monitoring Window is turned OFF, the CLM will have no way of detecting if a motor has Drive Runaway or Drive Stalled.

WARNING: If motion is interrupted by setting flags 98 or 99 ON, it will resume automatically when the output is turned OFF.

5.3 Multi-tasking

The CLM is capable of operating two motion programs and a background PLC program simultaneously when multiple tasks are programmed (see next section). This allows a single CLM to operate two independent processes at the same time or utilize multi-tasking in a single process.

5.4 Start of the Program

When the CLM is first powered up or an error is cleared, the program block pointer is set to block 0000 for Task 1. If Tasks 2 and 3 are used, they will start at their assigned starting point as user defined in parameter B006. All programs must start at their assigned starting points; Task 1 must start at block 0000. Blocks of numbers of programming will be followed sequentially unless a jump or branch instruction is encountered.

If block 2999 is executed and it is not a jump command, all motions are stopped, and an error code is displayed. Typically, the last command block you enter will be a jump command to return to the start of the next cycle or to return from a sub-program routine.

5.5 End of the Program

Take extreme care to control the flow of the program. This is especially important when using multi-tasking. Most programs are designed so they will loop back to the start of each task and wait for the proper sequence of events before starting again. Make sure that each task will not interfere with another task.

5.6 Programming Mode

The CLM must be in either Automatic or Manual mode to accept program entry/edit from the front panel. It is recommended that the CLM be placed in manual mode when editing the program, especially when this involves changing a command, or several blocks.

WARNING: Program entry in Automatic Mode, while the unit is in operation, will be accepted as soon as the Store key is pressed. The next time the block is scanned in the program, the updated data will be executed. It is recommended that the CLM be placed in Manual Mode when editing the program. Complete and verify the program changes before returning to Automatic Mode. Have accurate listings of the program and parameters when editing, to reduce the possibility of errors.

5.7 General Format

The general format, shown on the CLM control panel display during program entry / edit, is as follows:

E _0000 ABC
(DATA)

- E = shows the display is in the program edit mode
- 0000 = block number displayed; command or data can be viewed or edited.

You can select any block number 0000-2999 to display. To scroll through the block numbers, first press the **CR** key to locate the cursor in the top line (or use the left/right arrow keys). Then use the + and - keys to scroll up or down through the block numbers. You can also type the block number desired directly over the existing number.

- ABC = 3-letter mnemonic of command programmed in displayed block

To scroll through the commands, position the cursor to the right of the displayed command three letter mnemonic. Use the up or down arrow keys to scroll alphabetically through commands. When the desired command is on the display, press the right arrow key to select the command and move the cursor into the data field that appears for the specific command on the second line.

- (Data) = Each command requires entry of data specific for the command, as described in the following sections.

NOTE: The CLM display provides up to four lines of 16 character positions each. All display screens do not require all lines. This manual illustrates the displays at the size required for the data.

5.8 Command Summary

The various commands can be classified into categories by their function, as described in the following sections. These sections describe the general use and differences between all the programming commands. For future reference, you can use these sections to select the specific command desired for the general function. Then refer to that command description in section 5.9 for further details on how it works and requirements for its entry.

5.8.1 Positioning Commands

There are two major types of positioning commands: Incremental - movement from one point to the next point, or Absolute - movement in relationship to a known home point. These can be further broken into two different functional types of positional commands.

1. Commands that require the axis to be at the final programmed position, as determined by the In Position Signal, before stepping to the next block. These are identified by the letter "S" in the mnemonic (Stop).
2. Commands that, after being read into the position buffer, immediately go to the next block for further program execution. These are identified by the letter "O" in the mnemonic (Onward).

The following is a list of the position commands:

- POI Incremental position command
- PSI Incremental position command with In Position Acknowledged
- POA Absolute position command
- PSA Absolute position command with In Position Acknowledged
- POM Incremental or Absolute positioning to IDS thumbwheel switch setting
- PSM Incremental or Absolute positioning to IDS with In Position Acknowledged

Position commands have the following characteristics:

- Position commands must include Axis, Position or Distance, and Velocity.
- Positions are programmed directly in units of your choice: inches, metric, degrees, etc.
- You can select either two or three decimal points of accuracy (*in parameter B007*).
- The acceleration rates specified in parameter Ax02 will be used as defaults, unless they are changed with the ACC command prior to the motion.
- Select either Constant acceleration or Knee Point acceleration profile.
- Motion can be independent or simultaneous.
- Axis can be programmed for Rotary motion (rotation resetting to zero after one rev).

5.8.2 Position Support Commands

The following commands are used either in conjunction with a positioning command or by themselves to achieve the specific result.

- ACC Change acceleration/deceleration rate (0.1 to 99.9% of Ax02)
- AEO Acceleration Override
- ANC Analog Input Compare
- CLA Clear absolute position buffer (set to zero)
- COC Cam Output Control - turn 6 outputs ON or OFF at axis position
- CON Constant velocity command (sets axis to a continuous speed)
- DEC Deceleration Change
- FAK Factor all feed distances by a set ratio
- FOL Axis synchronization factor (master/slave mode)
- FUN Functions
- HOM Execute a homing routine
- KDI Copy a position difference to a target block
- MLO Material Length Output
- PBK Position break (immediate stop of selected axis)
- PST Position test (turn output ON/OFF based on position)
- REF Move at a set velocity until a registration mark is detected
- REP Maximum search distance for REF command (branch if exceeded)
- RMI Registration mark interrupt (high speed)
- SAC Set Absolute position reference
- SIN Sinusoidal oscillation
- SO1 Read inputs to program a distance into memory
- SO2 Alter next feed distance based on an analog input level (0 to 10 Vdc)
- VCA Velocity change absolute
- VCC Velocity change during a profile
- VEO Velocity override (analog/binary/factor override)
- WRI Write current position to a target block (Teach)

5.8.3 Branch Commands

These are commands for conditional program flow control, used to direct the actions of the control based on events that can be monitored by the CLM.

- BAC Branch when the item count is met (up to 99,999 counts)
- BCA Output-dependent conditional branch (1 to 99)
- BCB Binary inputs conditional branch (16 or 256 possible targets)
- BCD BCD input conditional branch (100 possible targets)
- BCE Single input-dependent conditional branch (1 to 88)
- BIO Branch if Input/Output mask matches (compares 10 bits)
- BIC Multiple input-dependent conditional branch
- BMB Binary output conditional branch (compares any # of outputs)
- BPA Parallel output conditional branch (compares 10 outputs)
- BPE Parallel input conditional branch (compares 10 outputs)
- BPT Branch on position reached (must be at position)
- BZP Branch if at or past a position

5.8.4 Jump Commands

Very similar to branch commands except they are not conditional; i.e., jumping takes place immediately when the command is read. Subroutines are also part of this category. They are common program sequences that are used repeatedly throughout a program, returning to the calling point when completed.

- APJ Turn parallel outputs ON or OFF, then jump
- CST Change subroutine stack level
- JMP Unconditional jump to a block
- JSR Jump to a subroutine
- JST Unconditional jump to a block, then stop the program
- JTK Immediately cause a jump to a block in a selected task (task interrupt)
- RTS Return from subroutine

5.8.5 Auxiliary Functions

Refers to the monitoring of Inputs and controlling the states of Outputs. This ability is vital for a control to be capable of acknowledging and responding to the external environment and to control functions other than motion. Note that branch commands and certain position support and jump commands (COC, PST, APJ) are also used for I/O interfacing.

Output control commands:

- AEA Turn a single output ON or OFF (1 to 89)
- APE Turn a parallel group of output ON or OFF (10 outputs, group 0-9)
- APJ Turn a parallel group of outputs ON or OFF, then jump (10 outputs)
- CIO Copy a group of inputs or outputs to a set of outputs (10 outputs)
- COC Turn 6 outputs ON or OFF based on Cam position
- PST Position test (turn output ON/OFF based on position)
- STO Send information to outputs

Input/Output monitoring commands:

- AKN Check a single input state, continue if state matches (1 to 88)
- AKP Check a parallel group of inputs, continue if all match (10 inputs, group 0-9)
- ATS Check a single output state, continue if state matches (1 to 99)

5.8.6 Counter Commands

Useful for tracking progress of a process. You can use any number of cycle/parts/batch counters within a program.

- BAC Branch until the item count is met (up to 99,999 counts)
- CLC Clears the counter at a block with a counter command in it (set to zero)
- COU Turn output ON at end of count (up to 999,999 counts)

5.8.7 Timer Commands

The LA firmware supports the delay of the program in a wait block for a preset time. It currently has no free standing times for asynchronous delays; counters or a separate program task must be used.

- WAI Wait for a set time delay, then move to next block (10 ms to 99.99 sec)

5.8.8 Other Commands

The following commands have the indicated function. Refer to the next section for a detailed description of every programming command.

- CID Change instruction data
- NOP No Operation
- RSV Restart vector
- STH Send to host (Communications)

5.9 Command Descriptions

This section describes each programming command. The first line of the illustrated displays are as previously described, with **E** indicating Edit Mode, a random block line number, the three letter mnemonic for the command and relative data fields.

This manual principally describes hardware version CLM 01.3-A with software version LA01.3-01.x. The software has parameter selected two or three decimal place precision in the commands that involve positioning and position related parameters (See Parameter B007).

Each command requires specific data. All places for required data in a user program block which contains illegal characters (a space or an undefined character - not a number or the +/- sign) are replaced by the asterisk character (*) in the display. This enables the user to easily recognize which points in a command data need to be programmed. A block of program has the correct syntax when it contains no asterisk (*) characters in the display.

NOTE: The following sections fully describe the use and data field entry requirements of each command. For easier reference, the commands are listed in alphabetical order and each command's description begins on a new page.

5.10 ACC Acceleration Change

E	0001	ACC
1	750	

- 1 - Axis (1, 2, 3 or 4)
- 750 - Acceleration in percentage of the acceleration rate set in parameter Ax02
 - Min.= 00.1%
 - Max.= 99.9%
 - One decimal place precision (i.e. 750 = 75.0%).

The ACC command allows the acceleration rate to be changed in the user program. The desired rate is programmed as a percentage of the acceleration entered in parameters Ax02.

Stepping to the next block takes place immediately after the block is read in. If you change this rate "on the fly" it will take effect starting with the next positioning command. A change in acceleration can only take affect if the feed comes to a complete stop. The change will not take affect if a feed is currently in progress.

The acceleration rate remains in effect for every positioning command until it is changed via another ACC command. If the CLM is taken out of Automatic Mode, the acceleration rate resets to the value programmed in the acceleration parameters Ax02.

NOTE: You can use the ACC command or Parameters Ax17 (Knee Point/Second Acceleration), but not both. When using one, the other does not function.

Example:

```

0000  NOP                               ; No operation
0001  ACC  1 750                         ; Change the acceleration rate to 75.0% of A102 (Axis 1)
0002  PSI  1 +00100.000 999             ; Axis 1, incremental feed, with acknowledgment, of
                                         ; +100.000 IU* at max speed
0003  WAI  005                           ; Wait, allows for axis motion to completely stop
0004  ACC  1 999                         ; Change the acceleration back to max. (the value set in
                                         ; A102)
0005  JST  0001                          ; Jump and stop to block 0001
                                         * IU= Input Units- desired unit of measure for positioning
    
```

5.11 AEA Auxiliary Output ON/OFF

E	0020	AEA
07	0	

- 07 - Auxiliary output number
- 0 - Output state
 - **0** = turn output **Off**
 - **1** = turn output **On**

The AEA command is used to set the state of any single auxiliary output. Stepping to the next block occurs immediately after this program block is read.

The auxiliary outputs retain their status when the CLM exits Automatic Mode into Manual Mode.

In a fault condition or the entry to Parameter Mode, the auxiliary outputs will automatically be set to the Off (0) state. Upon the clearing of the fault or exiting of Parameter Mode, the auxiliary outputs remain in the Off state until their status is changed in the user program in Automatic Mode.

WARNING: *The manipulation of aux. outputs 89 through 99 can have unexpected results. See Table 5.1 for more information on auxiliary outputs that serve as status markers.*

Example:

```

0000 JMP 0020 ; Jump to block 0020
0020 AEA 07 0 ; Turn auxiliary output 07 Off
0021 POI 1 00000.550 865 ; Axis 1, incremental feed of +0.550 IU at 86.5% of max
                        velocity (A101)
0022 ATS 15 1 ; Check auxiliary output 15 until On status (axis in position
                        per tolerance set in A106)
0023 AEA 07 1 ; Turn auxiliary output 07 On
0024 WAI 1.00 ; Wait 1 second
0025 JMP 0020 ; Jump to 0020 (repeat cycle)

```

5.11.1 AEO Acceleration Override

E	0043	AEO
1	2	0 400 500

- 1 - Axis (1, 2, 3 or 4)
- 2 - Override input selection
 - 0 = Override OFF or in accordance with Parameter B013
 - 1 = Analog value 0 to +10 Volts at the corresponding analog input (Axis 1: AE1 ... Axis 4: AE4)
 - 2 = Binary value at inputs 09-16 (Input 09=20 ... 16=27)
 - 3 = Gray code at inputs 13-16 (for significance of acknowledgement, see Parameter B013)
 - 4 = Override value from AEO command
 - 5 = Pulse frequency of measuring wheel encoder 1
- 0 - Override update
 - 1 = Read override input value only once (each time the command is executed)
 - 0 = Read override input value every program cycle
- 400 - Scaling factor (000-999) for input selection 5 only
- 500 - Acceleration limit (000-999) in per mil (%) of parameter Ax02

Override velocity factor using encoder 1

The Override via measuring wheel encoder 1 pulse frequency can be activated only if the axis in parameter A123 is configured as a “Normal Feed Axis” (setting: 0). The measuring encoder 1 must be configured correctly in parameters B016 through B019. Otherwise, indexing to the next statement is executed. The acceleration is changed according to the encoder frequency, so that the acceleration path remains constant from 0 to V-Drive=encoder velocity.

The AEO command is processed the same way as the ACC command, as soon as any positioning command in process is completed.

The new acceleration value is calculated as follows:

$$\text{Acceleration} \left[\frac{\text{EGE}}{\text{s}^2} \right] = \text{Parameter Ax02} \times \frac{\text{Encoder Speed} \left[\frac{\text{EGE}}{\text{s}} \right]}{(\text{Parameter Ax00})^2}$$

This relationship is only valid for commanded velocity 999.

When the scaling factor is selected, the new acceleration value is calculated as follows:

$$\text{Acceleration} \left[\frac{\text{EGE}}{\text{s}^2} \right] = \text{Parameter Ax02} \times \frac{\text{Encoder Speed} \left[\frac{\text{EGE}}{\text{s}^2} \right]}{(\text{Parameter Ax00})^2} \times \frac{\text{Scaling Factor}}{1000}$$

The acceleration cannot be below the minimum acceleration set in the AEO command.

5.12 AKN Acknowledge Single Input

E	0860	AKN
12	1	

- 12 - Auxiliary input number (01-16 or 81-88)

NOTE: Auxiliary input numbers 17-80 can also be used with expansion I/O option.

NOTE: Input 00 does not exist. AKN commands containing Input 00 result in an “Invalid Program Command” diagnostic.

- 1 - Input status
 - **0** = input status **Off**
 - **1** = input status **On**

With the AKN command, the CLM scans the status of the programmed auxiliary input for the specified state. Stepping to the next block will **not** take place until the desired status is present at the specified auxiliary input.

Example:

```

0000 JMP 0860 ; Jump to block 0860
0860 AKN 02 1 ; Scan aux input 02 until status is ON
0861 PSI 1 +00010.56 500 ; Axis 1 incremental feed, with acknowledgment, of +10.56
IU at 50% of maximum velocity (A101)
0862 AEA 11 1 ; Turn On auxiliary output 11
0863 JMP 0900 ; Unconditional Jump to block 0900
0900 AKN 02 0 ; Scan aux input 02 until status is OFF
0901 AEA 11 0 ; Turn OFF output 11
0902 PSI 1 -00010.56 999 ; Axis 1 incremental feed reverse, with acknowledgment, of
10.56 IU at 100% of maximum velocity (A101)
0903 JMP 0860 ; Jump to block 0860 (repeat cycle)
    
```

5.13 AKP Parallel Acknowledgment Input

E	0044	AKP
3	2100122011	

- 3 - Bank number 0-9 (group of 10 inputs)
 - Bank X = Inputs X0-X9, i.e. Bank 2= Inputs 20-29, Bank 3= Inputs 30-39, etc.
- 2100122011 input status (each of 10) as listed below:
 - **0** = the input will be checked for condition **Off**
 - **1** = the input will be checked for condition **On**
 - **2** = the input will not be checked - "**Don't Care**"

The AKP command is used to verify the status of a specific bank, or group, of ten auxiliary inputs. Stepping to the next program block takes place after all inputs have met their programmed status simultaneously.

NOTE: Input 00, of Bank 0, does not exist. Program this input with a “Don’t Care” (2) status. No error diagnostic is issued if this input is programmed with anything besides a Don’t Care condition.

NOTE: The standard CLM-01.3-A has a maximum of 24 auxiliary inputs that are physically accessible to the user. The CLM-01.3-A-E has expanded auxiliary input capability of 88 inputs.

The following page shows an example use of the AKP command.

The AKP command waits until all the specified aux. inputs, 10-19, have achieved the indicated status shown by the data field "0110201222".

E	0044	AKP
1	0110201222	

Bank 1 (tens) =	1	1	1	1	1	1	1	1	1	1
Individual # (ones) =	0	1	2	3	4	5	6	7	8	9
Input Number =	10	11	12	13	14	15	16	17	18	19
Programmed state	0	1	1	0	2	0	1	2	2	2

Inputs 10, 13 and 15 are checked for condition "OFF"
 Inputs 11, 12, and 16 are checked for condition "ON"
 Inputs 14, 17, 18 and 19 are not checked for a condition (Don't Care)

Example:

```

0000 NOP
0001 AEA 01 1 ; Turn ON output number 1
0002 AKP 1 0110201222 ; Scan inputs 10-19 until programmed state is matched
0003 AEA 01 0 ; Turn OFF output number 1
0004 JST 0001 ; Jump to block 0001 and stop
    
```

Programming inputs 17-19 with other than Don't Care (2) or using bank numbers 2-7 is only physically feasible with a CLM-01.3-A-E. The expanded aux. input capability allows the inputs 17-80 to be accessed. If inputs 17-19 were programmed with anything besides a Don't Care (2) condition in this example, the Standard CLM-01.3-A would hang-up in this block because the inputs will not be satisfied.

5.13.1 ANC Analog Input Compare

(as of software version LA04V07)

E 0010 ANC
1 ±1.52 ±9.99 01

- 1 - Analog input (1, 2, 3 or 4)
- ±1.52 - Minimum value (range: -9.99 to +9.99)
- ±9.99 - Maximum value (range: -9.99 to +9.99)
- 01 - Output or Flag
 - 00 = off
 - 01 = on

The input voltage is compared to a range of values, determined by the minimum and maximum values set in this command. If the voltage at the selected analog input is within the set limits, the output is set to “1” (on). If the voltage is outside the limits, the output is set to “0” (off). The output is set once each time the command is executed. The next program block is executed.

Parameter B013 can be programmed to compare the input voltage to an averaged value.

5.14 APE Activate Parallel Outputs

E	0044 APE
1	2100122011

- 1 - Bank number 0-9 (group of 10 aux. outputs)
 - Bank X => aux. outputs X0-X9, i.e. Bank 2= aux. outputs 20-29, Bank 3= aux. outputs 30-39, etc.
- 2100122011 aux. output status (each of 10) as defined below:
 - **0** = the aux. output will be reset to an **OFF** condition
 - **1** = the aux. output will be set to an **ON** condition
 - **2** = the aux. output will not be changed

The APE command sets the state of any programmed bank, or group, of ten aux. outputs. The desired bank of aux. outputs to be manipulated is first selected. The next ten digits set the status of each individual aux. output in the bank. Stepping to the next block takes place immediately after the APE command is read. The standard CLM has aux. output numbers 1-19. You can use aux. outputs number 20 through 88 as flags (bit memory).

WARNING: The manipulation of aux. outputs 89 through 99 can have unexpected results. Refer to Table 5.1 for more information.

NOTE: Auxiliary Output 00, of Bank 0, does not exist. Program this aux. output with a "Don't Change" (2) status. No error diagnostic occurs if this output is programmed with anything besides a Don't Change condition.

NOTE: The standard CLM-01.3-A has a maximum of 16 auxiliary outputs that are physically accessible to the user. The CLM-01.3-A-E has expanded auxiliary output capability of 48 outputs.

Example of the APE command:

The aux. outputs in Bank 1, aux. outputs 10-19, will be programmed to the states designated in the data field "2100122011" respectively.

```

E 0044 APE
1 2100122011
    
```

Bank 1 =		1	1	1	1	1	1	1	1	1	1
Individual # =	0	1	2	3	4	5	6	7	8	9	
Aux. Output Number =		10	11	12	13	14	15	16	17	18	19
Programmed state		2	1	0	0	1	2	2	0	1	1

Aux. Outputs 12, 13 and 17 are programmed for an "OFF" state.

Aux. Outputs 11, 14, 18, and 19 are programmed for an "ON" state.

Aux. Outputs 10, 15 and 16 are programmed with a Don't Change condition. This causes the output to remain in its previous state.

5.15 APJ Activate Parallel Output, then Jump

E	0304	APJ
1234		
1	2100122011	

- 1234 - Target block (0000-2999)
- 4 - Bank number 0-9 (group of 10 aux. outputs)
 - Bank X => aux. outputs X0-X9, i.e. Bank 2= aux. outputs 20-29, Bank 3= aux. outputs 30-39, etc.
- 2100122011 aux. output status (each of 10) as listed below:
 - **0** = the output will be reset to an **Off** condition
 - **1** = the output will be set to an **On** condition
 - **2** = the output will not be changed

This command can be used to check simultaneously if a condition is being met at 10 inputs of the CLM. The condition can be specified separately for each output.

The jump to the target block takes place only if all 10 inputs meet the programmed condition.

NOTE 1: Output 00, of Bank 0, does not exist. Program this aux. output with a “Don’t Change” (2) status. No error diagnostic occurs if this output is programmed with anything besides a Don't Change condition.

NOTE 2: The standard CLM-01.3-A has a maximum of 16 auxiliary outputs that are physically accessible to the user. The CLM-01.3-A-E has expanded auxiliary output capability of 48 outputs.

WARNING 1: If the Monitoring Window is turned OFF by setting flag 95 or 96 to ON, the CLM will have no way of detecting if a motor has Drive Runaway or Drive Stalled.

WARNING 2: If motion is interrupted by setting flag 98 or 99 ON, it will resume automatically when the output is turned OFF.

The following is an example of the APJ command.

The aux. outputs in Bank 4, outputs 40-49, will be programmed to the states designated in the data field "2100122011" respectively. The program then jumps to the desired block designated by the data "0100" in the example.

```

E 0044 APJ
0100

4 2100122011
```

- 0100 - After the designated bank of aux. outputs have been programmed, the program jumps to this block.

Bank 4 =		4	4	4	4	4	4	4	4	4	4
Individual # =	0	1	2	3	4	5	6	7	8	9	
Aux. Output Number =		40	41	42	43	44	45	46	47	48	49
Programmed state		2	1	0	0	1	2	2	0	1	1

Outputs 42, 43 and 47 are programmed for an "OFF" state.

Outputs 41, 44, 48, and 49 are programmed for an "ON" state.

Outputs 40, 45 and 46 are programmed with a Don't Change condition. This causes the output not to change state.

The aux. outputs shown, 40-49, only serve as flags if a CLM-01.3-A is being programmed. If the CLM-01.3-A-E is being programmed, the aux. outputs up to 48 are accessible. Auxiliary output 49 serves as a flag because it is not physically accessible.

5.16 ATS Acknowledge Output Status

E	0050	ATS
05	1	

- 05 - Auxiliary output number scanned
- 1 - Auxiliary output status
 - **0** = output status **Off**
 - **1** = output status **On**

The ATS command scans the status of the programmed aux. output. Stepping to the next block does not take place until the desired status is present at the specified aux. output. This command is used to perform handshaking with a parameter specified output or with an output whose state is changed by another task number.

All aux. outputs can be monitored and used in the execution of an ATS command. Auxiliary outputs 73 through 99 function differently than other aux. outputs. See Table 5.1 for more information.

The following example shows how the ATS command is used to test axis position. The program can be held up until the moving axis is in position by monitoring the "In Position" output programmed in Parameters Ax06 for each axis.

Example:

The "In Position" output programmed for Axis 1 is number 15 (Aux. output 15 is Off while Axis 1 is in motion until it is "In Position" at which time it will come On).

```

0500 POI 1 +00100.15 39.5 ; Incremental position command, Axis 1, +100.15 IU at
                          39.5% of max. feed rate.
0501 ATS 15 1 ; Poll status of aux. 15 for an On status (Axis 1 has reached
                          position).
0502 AEA 02 1 ; Turn On aux. output 02.
0503 JST 0000 ; Jump and Stop at Block 0000.
    
```

5.17 BAC Branch And Count

```

E 0060 BAC
1234 +0000 00500
    
```

- 1234 - Target Block (0000-2999)
 - +0000 - Offset Value
 - 00500 - Preset Count

Each time this block is executed, the Actual Count increments by one. Program branching to the Target Block occurs **until** the Actual Count equals the Preset Count. Then, the Actual Count is set to zero and stepping to the next program block number takes place. See Counter Display screen example below.

Information about the Offset Value:

- +1234 - add Offset Number of items to Actual Number of items
- -1234 - subtract Offset Number of items from Actual Number of items
- 00000 - delete Actual Number of items
- +0000 - Actual Number of items unchanged
- -0000 - Actual Number of items unchanged

This is an example of the Counter Display screen (See Chapter 2 for procedures to scroll through displays and view the Counter Display screen).

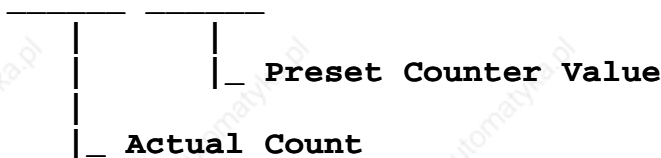

Immediately after this block is stored in memory, the Offset Value entered is summed with the Actual Count and becomes the New Actual Count. Then, the Offset Value in the BAC program block display is set to "+0000." This ensures that the Actual Number of items is only affected once (for instance, if Store is pressed again, the actual count will not be changed).

The jump to the Target Block continues to be executed until the programmed Preset Count has been reached. After that, the CLM steps to the next block and the Actual Counter is set to zero. The Actual Count can also be set to zero by using the program command "CLC".

Example:

Assume the Preset Count desired is normally 100. At this time, the Actual Count is 50. However, you desire only 20 more pieces, 70 total. Program the BAC block as follows:

The Offset Number data field should be programmed with a "+0030".

E	0060	BAC
1234	+0030	00100

When you press the Store key, the Actual Count is set to 80 (when viewing the Counter Display screen). Therefore, the Preset Count is reached after 20 counts, resulting in 70 total parts. All times after that, the counter starts at 000000, resulting in 100 increments.

The same holds true if a negative number is entered in the Offset Number data field of the BAC program block. Using the same example as above, if an Offset Number of <-0030> was entered, the Actual Count starts at 20. Therefore, 80 increments are encountered before the 100 Preset Count is achieved. Thereafter, the Actual Count begins at 000000.

If a negative Offset Number entered is greater than the Actual Count, the Actual Count will be set to zero. The Actual Count cannot be set to a negative value (set to do less than zero increments).

An example use for this command would be when you need to make up for bad parts. Let's say you had a jam, reached the end of the roll of material, or for some other reason you have five defective parts. Now instead of 100 parts, you need 105 parts to make your production quota. There are two things that can be done to the program block containing the BAC command. The Preset Count can be changed from 100 to 105 parts or <-0005> can be entered as an Offset Value to yield five extra parts (by decrementing the Actual Count by five parts). If the Preset Count is modified, a new Preset Count may need to be entered for proper quantity of parts per quota.

5.18 BCA Branch Conditional on Acknowledgment (Output-Dependent)

E	0070	BCA
1234	22	0

- 1234 - Target block (0000-2999)
- 22 - Auxiliary output number (01-99)
- 0 - Jump condition
 - 0 = jump if aux. output is Off
 - 1 = jump if aux. output is On

A jump is executed if the programmed output meets the preselected condition (0/Off or 1/On). If the condition is not met at the programmed output, the program steps to the next block, instead of branching to the target block.

Example:

Assume that the following conditions exist: a part requires a constant absolute positioning by Axis 1 to +8.125 inches. Then, the program needs to jump to one of two places, dependent on the status of output 20, for an absolute positioning by Axis 2. In this example, output 20 is turned ON in another part of the program. To run this program, both axes must first be homed.

```

0000 JMP 0053 ; Jumps to block 0053
0053 PSA 1 +8.125 999 ; Axis 1, absolute positioning to +8.125 in. at max. feed
      rate.
0054 BCA 0100 20 1 ; Jump to block 0100, if output 20 is ON (ON in this
      example)
0055 BCA 0200 20 0 ; Jump to block 0200 if aux. output 20 is OFF
0056 JMP 0054 ; Program execution could progress to here, if output 20
      turns ON after block 0054 executes, scan output 20 again
0100 PSA 2 +5.25 75.5 ; Axis 2 absolute position to +5.25 in. at 75.5% max. feed
      rate
0101 JST 053 ; Jump to beginning of cycle at block 0053 and stop
0200 PSA 1 +0.000 500 ; Axis 1 absolute position to 0.0 IU at 50% velocity
0201 PSA 2 +0.000 200 ; Axis 2 absolute position to 0.0 IU at 20% velocity
0202 JST 0000 ; Jump to beginning of cycle and stop

```

5.19 BCB Binary Conditional Branch (Inputs)

E	0080	BCB
1234	12	1

- 1234 - Block Offset
 - 12 - Length of jump
 - 1 - Auxiliary input bank selection (can be 1, 2, or 3) (This determines the location of the Binary inputs)

The BCB command executes a jump which has been defined by means of the Binary Inputs at the aux. inputs 1 to 8, relative to input bank selection.

The target block is calculated as follows:

$$\text{Target Block} = \text{Offset} + (\text{Binary Input Value} \times \text{Length of Jump})$$

The Binary Input Value should be converted to a decimal value to calculate the target block.

The Binary input location can be selected from the following:

Input Bank Selection 1 - use auxiliary inputs 1-4

Aux. Input:	4	3	2	1
Binary: 2^3	2^2	2^1	2^0	
Significance				
Decimal:	8	4	2	1
Significance				

Input Bank Selection 2 - use auxiliary inputs 5-8

Aux. Input:	8	7	6	5
Binary: 2^3	2^2	2^1	2^0	
Significance				
Decimal:	8	4	2	1
Significance				

With input bank selection 1 or 2, a total of 15 targets is possible.

Input Bank Selection 3 - use auxiliary inputs 1-8

Aux Input:	8	7	6	5	4	3	2	1
Binary:	2^7	2^6	2^5	2^4	2^3	2^2	2^1	2^0
Significance								
Decimal:	128	64	32	16	8	4	2	1
Significance								

With input bank selection 3, a total of 256 targets is possible.

NOTE: There is no "Invalid Program Command" diagnostic if this command is programmed to exceed block 2999. That is because the destination block is dependent on the value determined from aux. inputs (relative to the Binary Input Value selected). However, an "Invalid Block #" diagnostic is issued when the BCB command is executed and the destination block exceeds program block 2999.

5.20 BCD BCD Conditional Branch

E	0090	BCD
0100	12	

- 0100 - Block Offset
- 12 - Length of jump

The BCD command executes a jump which has been defined by means of BCD (Binary Coded Decimal) inputs at the auxiliary inputs 1 to 8.

The target block is calculated as follows:

$$\text{Target Block} = \text{Block Offset} + (\text{BCD Input Value} \times \text{Length of Jump})$$

The BCD Input Value should be converted to a decimal value to calculate the target block.

If a parallel input is not sensed in the BCD format, this will result in "BCD Input Error" diagnostic.

Aux.:	8	7	6	5	4	3	2	1
Inputs								
BCD:	80	40	20	10	8	4	2	1
Significance								

Example:

Aux.:	8	7	6	5	4	3	2	1
Inputs								
BCD Input =	0	1	0	1	0	0	1	1
Decimal								
Equivalent =			50		+			3
Target Block =	0100 + (53 x 12) = 0736							

In the example above, a jump to block 0736 takes place.

Aux.:	8	7	6	5	4	3	2	1
Inputs								
BCD Input =	0	0	0	1	0	0	0	1
Decimal								
Equivalent =			10		+			1
Target Block =	$0100 + (11 \times 12) = 0232$							

Example:

If BCD input(decimal equivalent) = 00 - jump to block 0100

- 01 - jump to block 0112; offset of $0100 + (1 \times 12)$
- 66 - jump to block 0892; offset of $0100 + (66 \times 12)$

NOTE: There is no "Invalid Program Command" diagnostic if this command is programmed to exceed block 2999. That is because the destination block is dependent on the value determined from aux. inputs (relative to the BCD value selected). However, an "Invalid Block #" diagnostic is issued when the BCD command is executed and the destination block exceeds program block 2999.

5.21 BCE Branch Conditional on Input

E	0100	BCE
1234	01	0

- 1234 - Target block
- 01 - Auxiliary input number (1-16 or 81-88)

NOTE: Auxiliary input numbers 17-80 can also be used with expansion I/O options.

- 0 - Condition:
 - 0 = jump if input is OFF/low
 - 1 = jump if input is ON/high

A conditional jump to the target block will be executed if the auxiliary input meets the preselected condition (0 or 1). If the condition is not met at the programmed input, stepping to the next block takes place.

One use of this command is to allow selecting different routine programs to run for making different parts, by turning ON a different switch on the control panel. In the following example, the main program runs, then branches and executes the routine program indicated by the first input that is high (ON). The last block of the routine can jump back to the first block of the main program for continuous operation. It can jump back to the beginning of the main program (block 0000), and branch to the respective block for the input that is high.

Example:

```

0000  NOP
0001  BCE  0600 01 1 ; Branch to block 0600 if input 01 is high
0002  BCE  0700 02 1 ; Branch to block 0700 if input 02 is high
0003  BCE  0800 03 1 ; Branch to block 0800 if input 03 is high
0004  BCE  0900 04 1 ; Branch to block 0900 if input 04 is high
0005  JMP  0000 ; Jump to beginning of cycle at block 0000 (scan inputs 1-4 again)
    
```

5.22 BIO Branch Input/Output Compare

```
E 0801 BIO
1321
4 1111222222
```

- 1321 - Target Block Number
- 4 - Bank number 0-9 (group of 10 aux. inputs/outputs)
Bank X => aux. I/O X0-X9, i.e. Bank 2= aux. I/O 20-29,
Bank 3= aux. I/O 30-39, etc.
- 1111222222 aux. inputs/outputs states for comparison. States are defined below:
 - 0 = I/O compared for **OFF** condition
 - 1 = I/O compared for **ON** condition
 - 2 = I/O not compared - **Don't Care**

This command is used to check the aux. inputs identified with "1" for the level input "1" if the aux. outputs of the same number have been set to "1". The jump to the target block takes place when the condition is met.

The inputs in the BIO data marked with "0" or "2" will not be checked. The only comparison that will cause a jump is if each respective BIO data = "1", output = "1" and input = "1".

Example:

```
E 0801 BIO
0040
1 1111000000
```

Inputs and outputs from 10 to 13 will be compared

BIO Data	10="1"	11="1"	12="1"	13="0"	14="0"		
Outputs	10="1"	11="1"	12="1"	13="0"	14="1"		
Inputs	10="1"	11="1"	12="0"	13="1"	14="1"		
Condition	met		met	not met	not check	not check	

Since the condition is not being met at one point (input 12), the jump will not be executed. Stepping to the next program block takes place instead.

5.23 BMB Branch on Multiple Binary Outputs

```
E 0120 BMB  
0123 45 67 8
```

- 0123 - Block Offset
- 45 - Length of Jump
- 67 - Starting Output Number (01-99)
- 8 - Number of Outputs (consecutive) Being Used

This command will cause a jump to be executed which is determined by means of the output assignment as defined in the command.

Example:

```
E 0120 BMB  
0100 02 05 8
```

Outputs	12	11	10	09	08	07	06	05
Significance	128	64	32	16	08	04	02	01
Output value	0	0	1	1	0	0	1	1
Output value =	51							

The target block is calculated as follows:

- Block offset + (output value x length of jump)
- 0100 + (51 x 02)
- Target block = 0202

5.24 BPA Branch on Parallel Acknowledgments (Outputs)

E 0130 BPA 1234 5 1111000022

- 1234 - Target Block
- 5 - Bank number 0-9 (group of 10 aux. outputs)
- 1111000022 Output State (each of 10) as listed below:
 - 0= the output will be checked for condition Off
 - 1= the output will be checked for condition On
 - 2= the output will not be checked - Don't Care

This command represents an expansion of the command BCA. It can be used to check if a condition is being met at 10 aux. outputs of the CLM. The condition can be specified separately for each output.

The jump to the target block takes place only if all 10 aux. outputs meet their programmed condition. If not, stepping to the next block takes place.

5.25 BPE Branch on Parallel Inputs

E	0150	BPE
1345		
6	1111000022	

- 1345 - Target Block
- 6 - Bank number 0-9 (group of 10 aux. outputs)
- 1111000022 Input State (each of 10) as listed below:
 - 0 = the input will be checked for condition OFF
 - 1 = the input will be checked for condition ON
 - 2 = the input will not be checked - Don't Care

This command represents an expansion of the command "BCE". It can be used to check simultaneously if a condition is being met at 10 inputs of the CLM. The condition can be specified separately for each input.

The jump to the target block takes place only if all 10 inputs meet the programmed condition. If not, stepping to the next block takes place.

5.26 BPT Branch on Position Test

E 0006 BPT 1456 2 +12345.678

- 1456 - Target Block
- 2 - Axis Number (1, 2, 3 or 4)
- +12345.678 Absolute Position (2 or 3 decimal places, as set in B007)

This command can be used to check absolute positions. If the axis is in this position (+/- switching tolerance set in Ax06), the jump to the target block will take place. If not, stepping to the next block takes place.

NOTE: BPT only functions after the axis has been homed. Prior to this, the block is scanned only and no execution takes place.

5.27 BZP Branch If the Target Position Exceeds the Position Limit

E 0155 BZP 1678 2 +12345.678

- 1678 - Target Block
- 2 - Axis Number (1, 2, 3 or 4)
- +12345.678 Position Limit Value (to 2 or 3 decimal places, as set in B007)

You can use this command to check that a commanded positions does not exceed the position limit value set by this command.

At the execution of this block, the jump to the target block takes place if the actual position, or the target position, of the axis, is equal to or greater than, the programmed position limit value.

If the actual position is less than the programmed position limit value, the program steps to the next block, instead of jumping to the branch block number.

NOTE: The BZP command only functions after the axis has been homed. Otherwise, the block is scanned only. It is not executed.

5.28 CID Change Instruction Data

E 0240 CID 1234 1 0 +0000001

- 1234 - Target block in which the information is to be changed
- 1 - Type of information:
 - 1 = The first variable in the target block is processed (e.g., the length in POI command)
 - 2 = The second variable in the target block is processed (e.g., the velocity in POI command)
- 0 - Operation value added or subtracted
 - 0 = Add or subtract operation value (depending on sign of change value)
 - 1 = Same as 0, but the result of the operation must be positive, otherwise the operation will not be carried out
 - 2 = Same as 0, but the result of the operation must be negative, otherwise the operation will not be carried out.
 - 3 = Overwrite information with the prefix in the target block
- +/-
 - '+' = the change value is added to target value
 - '-' = the change value is subtracted from the target value
- 0000001 - The information in the target block (specified by the entry for 'type of information') is changed by this amount.

This command changes the data in another block. Stepping to the next block takes place when the data changes in the target block have been completed or when, due to restrictions, no change can be carried out. If the target block includes no valid command, stepping to the next block will take place without any changes in the target block. For CON and FOL, designation of the information type has no significance.

Command	Type of Information		
	1	2	
CON	Velocity in %	Velocity in %	
FOL	Axis synchronization factor	Axis synchronization factor	
POI, PSI, POA, PSA	Length	Velocity in %	
PST, BPT	Test position	Test position	
JMP	Target block	Target block	
VCA	Position	Velocity in %	
WAI	Wait time	Wait time	
VEO	Override value	Override value	as of Software version 04VRS

NOTE: It is only possible to process one CID, KDI or WRI command at a given time. The commands waiting in other tasks will be delayed until completion of the first instruction.

5.29 CIO Copy Input/Output to Output

E	0160	CIO
1	03 75	9

- 1 - 0 = Copy source auxiliary inputs
 - 1 = Copy source auxiliary outputs
 - 2 = Copy source system inputs
 - 3 = Copy source system outputs
- 03 - First Input/Output Number looked at (Copy Source, 01 to 90)
- 75 - First Output Number to Copy to (Copy Target / Destination, 01 to 80)
- 9 - Quantity of I/O to be Copied (1-9)

This command can be used to copy the status of several inputs or outputs to other outputs.

WARNING: The manipulation of aux. outputs 89 through 99 can have unexpected results. Refer to Table 5.1 for more information.

Example: Five inputs are copied to five outputs;

E	0160	CIO
0	01 23	5

Results of this command can be monitored using the input/output status display. Status of the inputs are displayed as:

CLM Inputs 1-16
1.1.111..1.1..1.

Status of inputs 1-5 = **10101**

Status of the outputs before the command is executed:

CLM Outputs17-32
1..11..111.11.1.

Status of outputs 23-27 = **01110**

Status of the outputs after the command is executed:

CLM Outputs17-32
1..11.1.1.111.1.

Status of outputs 23-27 is now **10101**

5.30 CLA Clear Axis (Absolute Encoder Value)

E	0170	CLA
2		

- 2 - Axis Number (1, 2, 3 or 4)

This command is used to set the absolute value position register to zero. An offset measure from parameter Ax11 is taken into consideration. To use this command, parameter Ax10 must be programmed for using an incremental encoder or absolute value encoder. Otherwise, the message "illegal command" will appear when the command CLA is called up.

Incremental/absolute value encoder:

- The absolute value counter is set to zero, giving consideration to the offset measure at the current axis position.

If there is an incremental encoder:

- The output "home established" is set to 24-volt potential (see parameter Ax12).
- Absolute positioning is enabled.

Application: Enable of the absolute positioning with incremental encoder even without homing (for instance; reference positioning but always feeding in the same direction).

5.31 CLC Clear Counter

E	0080	CLC
1234		

- 1234 - Counter block number (0000-2999)

Use this command to clear (set to zero) the actual value of the counter at the indicated block number. If the indicated block does not contain the count command "COU" or "BAC", this block is only scanned.

5.32 COC Cam Output Control

E	0020	COC
1	05	110022 +090

- 1 - Axis Number (1 or 2)
- 05 - Number of the first of six aux. outputs to be set
- 110022 - Status of the 6 aux. outputs starting with the first:
 - 0 = resets output to Off
 - 1 = sets output to On
 - 2 = output remains unchanged
- +090 - Test position of axis in Input Units to zero or one decimal place (can be + or)
 - If B007 is set for 2 decimal places (B007= xx02xxxx), the test position has *no* decimals (i.e. 360= 360).
 - If B007 is set for 3 decimal places (B007= xx03xxxx), the test position has *one* decimal (i.e. 360= 360.0).

The COC command sets a bank of six aux. outputs relative to the axis position in degrees. The CLM waits for the programmed axis to reach the test position before setting the six aux. outputs to the desired states. The first of six consecutive aux. outputs to be changed is entered in the program block. The CLM then advances to the next program block.

Due to the scan time, the delay of setting the output states compared to the axis position can take up to 0.002 seconds (or more, see parameter B015). Therefore, the actual position of the axis when the outputs are set can vary with the present velocity of the axis. The formula used to calculate the accuracy of the outputs is:

Minimum actual position the outputs will turn ON = Test position + (velocity x 0.002 sec)

Velocity = Present velocity in IU/sec that the axis is traveling when COC command is pending.

If the axis has been homed, all test positions are taken in reference to the current absolute position. If the axis has not been homed, the test position is taken in reference to the last incremental feed.

Example: If the axis is traveling at 50"/sec and a COC test position of 12" is programmed, the outputs will be set at a position of between 12.000" and 12.024" (12 + [50 x 0.002] = 12.024")

Set up A216 for Rotary Table, A208 for 360 degree feed constant and the system implements an incremental encoder for position feedback.

0000 CLA 2 ; Sets actual position counter for axis 2 to zero
(initializes axis).

0001 APE 0 2000000222 ; Sets all cam outputs (aux. outputs) 1 through 6 to the
Off state.

0002 CON 2 1 +001 00 ; Sets Axis 2 into continuous motion at 0.1% of max.
velocity.

0003 COC 2 01 001100 +005 ; Waits for the 5-degree mark, then turns On cam
outputs (aux. outputs) 3 and 4.

0004 COC 2 01 001101 +090 ; Waits for the 90-degree mark, then turns output 1
Off and 6 On.

0005 COC 2 01 000001 +180 ; Waits for the 180-degree mark, then turns output 3
and 4 Off

0006 COC 2 01 000000)360 ; Waits for the 360-degree mark, then turns all outputs
Off.

0007 JMP 0003 ;Jump to block 0003.

5.33 CON Continuous Operation

E	0190	CON	
2	1	+345	01

- 2 - Axis number (1, 2, 3 or 4)
- 1 - Start/stop continuous operation (0=stop, 1=start)
- +345 - Speed in % to 1 decimal place
 - +/- direction (relative to Direction of Operation Parameter Ax09)
- 01 - Output (auxiliary function) to turn ON when CON velocity is achieved
 - 00 = no output

WARNING: Subsequent commands relating to the axis programmed here may be affected by the continuous operation. If the axis has limited travel (i.e. ballscrew), safeguards should be taken to assure the axis will be stopped before travel limit is exceeded.

An output can be programmed which is set to "1" once the continuous operating velocity has been reached. Axis position commands should not be used while continuous operation is on. This command will not be executed for an axis with an absolute value encoder.

The following example could be used on a web application to run speeds to keep a loop storage accumulator filled:

```

init 0000 JMP 0100 ; Jumps to block 0100
      0100 CON 1 1 +750 00 ; Feed at initial Fill Speed (75%)
      0101 BCE 0110 02 1 ; Branch to 0110 if first loop light (input 02) is
                          covered/input high (normal running),
      0102 BCE 0120 03 1 ; Branch to 0120 if second loop light (input 03) is
                          covered/input high (loop full)
      0103 JMP 0101 ; Scan inputs 02 and 03 again (continue fill speed)
norm 0110 CON 1 1 +500 02 ; Change speed to 50%, turn ON "loop normal"
      output
      0111 BCE 0100 02 0 ; Branch if accumulator storage is low
      0112 BCE 0120 03 1 ; Branch if accumulator is full
      0113 JMP 0111 ; Scan again for low/full conditions (inputs 02 and 03)
full 0120 CON 1 0 +000 00 ; Stop feeding, accumulator is full
      0121 AEA 03 1 ; Turn ON "storage full" output
      0122 AKN 03 0 ; Wait for additional material to be removed to
                          uncover loop full sensor
      0123 AEA 03 0 ; Turn OFF "storage full" output
      0124 JMP 0110 ; Resume at normal running speed (block 0110)

```

5.34 COU Count

```
E 0200 COU
+12345 12 123456
```

- +12345 - Offset number of items
- 12 - Signal (aux.) output number
- 123456 - Preset number of counts

Once this block has been read, the actual item number is increased by 1. Once the preselected item count has been reached, the programmed output is switched on. The actual value is subsequently cleared. The item counter can be also set to zero by using the command 'CLC.' Any number of item counters can be programmed.

For an example of how to offset the actual count, refer to the example for the BAC command.

This is an example of the Counter Display screen (See section 2.3.4 for information how to view the Counter Display screen).

_____ Program Block Number of **COU** command
|

```
C 0200 Counter
000056 000500
```

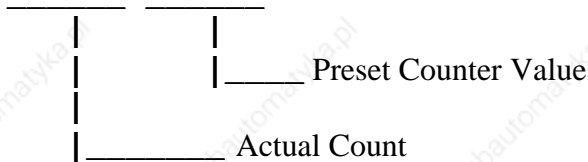

5.35 CST Change Subroutine Stack

E	0201	CST
1	4	

- 1 - Changes subroutine level (0-2, 4-5)
 - 0 = changes subroutine level in Task 1 and Task 2.
 - 1 = changes subroutine level in Task 1 only.
 - 2 = changes subroutine level in Task 2 only.
 - 4 = changes subroutine level in Task 4 only.
 - 5 = changes subroutine level in Task 5 only.
- 4 - Set subroutine stack to this level
 - 0 = sets stack to zero (See Note below.)
 - 1-9 = change subroutine stack level from one to nine levels

The starting block for Task 2 is set up in "Parameter B006 - 3 Layer Task Assignment". Task 1 programming does not need to be set up in parameters.

The CST command is used to change to different subroutine stack levels. It is used in conjunction with JSR and RTS. Task 1 and Task 2 have a maximum number of nine stack levels that can be changed in a single CST command. The CST command can be used in subroutines to allow for more functions when program space is limited.

After using a CST command to correct a stack, the next RTS command will jump the program beyond undesirable subroutines to a selected level.

NOTE: If the stack is set to zero, an RTS command cannot be used as this becomes the programs main level. If an RTS command is used after setting the stack to zero, the error "RTS Nesting" will occur.

Example:

The following example shows the program flow and the CST command (Subroutine level 3, block, "E309 CST 1 1", is used to change the subroutine stack level to level 1, in Task 1).

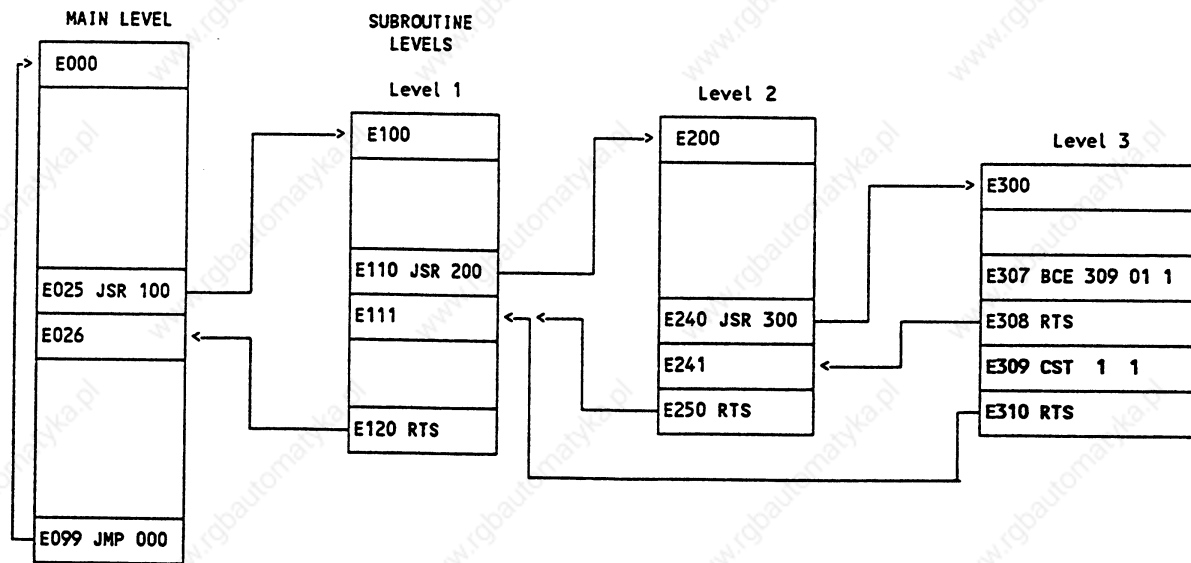

5.35.1 DEC Deceleration Change

E	0002	DEC
1	100	

- 1 - Axis (1, 2, 3 or 4)
- 100 - Deceleration in percentage of the deceleration rate set in parameter Ax24
 - Min.= 00.1%
 - Max.= 99.9%

NOTE: One decimal place precision (i.e. 750 = 75.0%).

The DEC command allows the deceleration rate to be changed in the user program. The desired rate is programmed as a percentage of the deceleration entered in parameter Ax24.

Stepping to the next block takes place immediately after the block is read in. If you change this rate "on the fly" it will take effect starting with the next positioning command. Then, a change in acceleration can only take effect if the feed comes to a complete stop. The change will not take effect if a feed is currently in progress. This command has no function if the jerk constant is inhibited (Parameter Ax25).

The deceleration rate remains in effect for every positioning command until it is changed via another DEC command. If the CLM is taken out of Automatic Mode, the deceleration rate resets to the maximum value programmed in acceleration parameter Ax24.

NOTE: Acceleration change is regulated by the ACC command.

5.36 FAK Factor All Motions

```
E 0210 FAK  
2 1.999999
```

Global position correction (factor all feeds)

- 2 - Axis 1, 2, 3 or 4
- 1.999999 - Multiplication Factor - 0.000000 to 1.999999

This programmable factor is used to multiply the feed length or position in feed commands. The feed rate is not changed. At the start of operating mode Automatic, the factor = 1.0000 until it is changed by the command FAK. The factor remains in effect until a new value is read with the command FAK during program execution.

Example:

```
E 0000 PSI  
1 +00010.000 200
```

= 10.0 inches feed at 20% feedrate

```
E 0001 WAI  
01.00  
E 0002 FAK  
1 0.500000
```

= multiply feed by 0.5

```
E 0003 PSI  
1 +00010.000 200
```

= 5.0 inches feed (0.5 x 10.0) at 20% feedrate

```
E 0004 JST  
000
```

A new value for the factor has no effect on the length of a feed currently still in progress. The FAK factor takes affect on the next feed command.

5.37 FMS Follow Master

E	0000	FMS
1	170.0	01 01 00

- 1 - Axis (axis #1 only)
- 170.0 - Feed end point, in degrees
- 01 - Input for start of feed
 - 01+1 = Input feed correction 'plus'
 - 01+2 = Input feed correction 'minus'
- 01 - Output for end of feed
- 00 - Not used, set to 00

Output for end of feed is off at the beginning of the condition. At the end of the feed (feed end point reached) this output is turned on.

Input for start of feed; feed begins at the leading edge of this input. With the start, feed length and correction from the IDS-01 is accepted. The start point corresponds to an angle of 0 degrees.

5.38 FOL Follow (Axis Synchronization)

E	0220	FOL
2	1	+1.234567

- 2 - Axis number to be the slave (#1 or 2 only)
- 1 - Synchronizing axis mode
 - 0 = Off
 - 1 = On
- + - Following direction
 - + (plus sign) = same direction
 - - (minus sign) = opposite direction
- 1.234567 - Synchronizing factor
 - Min. = 0.000000
 - Max. = 9.999999

NOTE: If all zeros are entered, the following axis no longer follows the master axis.

If the function Master Encoder (parameter B008) is selected, the slave axis executes all movements in synchronism with the master axis. The follow-on movement can take place in any ratio (1 = 1:1, 2 = 1:2, etc.). This ratio is initially set by comparing the axis parameters Ax04 and Ax08 with the measuring encoder parameters B009 and B010 respectively when powering up or when leaving Parameter Mode. The ratio can then be modified by the FOL command factor in the program.

If axis 1 is the master, only move commands for axis 1 need be programmed in subsequent blocks. The slave axis will still respond to move commands (i.e. POI) in subsequent blocks. The resultant speed will be the sum of the synchronous speed and the POI speed.

NOTE: Filtering (averaging) might be required to prevent motor noise (see parameter Ax15).

CAUTION: The command to the slave amplifier is not limited by the acceleration parameter Ax02. The acceleration rate commanded will be the acceleration rate of the master encoder times the ratio of master:slave times the FOL synchronizing factor.

5.39 FUN Functions

E	0123	FUN
0	0 1	1100

- 0 - Unassigned, set to 0
- 0 - Unassigned, set to 0
- 1 - Feed length measurement, measuring wheel (0 = off, 1 = on)
- 1 - Feed length measurement, axis 1 (0 = off, 1 = on)
- 1 - Feed length measurement, axis 2 (0 = off, 1 = on)
- 0 - Feed length measurement, axis 3 (0 = off, 1 = on)
- 0 - Feed length measurement, axis 4 (0 = off, 1 = on)

Significance of the inputs:

- 0 = Temporarily store measured value and then clear
- 1 = Clear the measurement logger (start new measurement). A temporarily stored value is retained.
- 2 = No change

Status 46 is used to request the temporarily stored measurements via the serial interface.

Example: The feed length traversed by axis 1 is to be determined after 10 events.

```

AKN 01 1
FUN 0 0 0 1000
AKN 01 0
AKN 01 1
Cnt  BAC loop +0000 0009
JMP end
LoopBCE cnt 01 0
JMP loop
End  AKN 01 1
     FUN 0 0 0 0000

```

5.40 HOM Home Axis

E	0230	HOM
1		

- 1 - Axis number (1, 2, 3 or 4)

Homing proceeds according to how parameters Ax10 - Ax14 have been programmed. Stepping to the next block takes place immediately after the block has been read in. This allows homing of all enabled axes simultaneously (with one task). Programming measures must be taken (ATS, AKN) to prevent absolute positioning commands (POA, PSA, etc.) from being encountered, before the homing sequence is completed, or an error message will be issued. An ATS command program-med to monitor the "Home Established" output (Parameter Ax12) will prevent stepping to the next block until the homing sequence is finished.

If the HOM command is used for an axis with an absolute value encoder, it will result in an error message.

NOTE: There are alternatives to Homing an axis, other than using this predefined routine. They are described in Appendix A, as LA Programming Notes, number .001 and in section 3.2.5.

5.41 JMP Jump Unconditional

E 0250 JMP 1234

- 1234 - Target block

When this command is encountered in a given task, the program immediately jumps to the specified target block.

There are several other commands that also provide an unconditional jump, and provide added features in the same block. They can be useful when program space is limited. Refer to section 5.8, Command Summary, for alternatives.

5.42 123 Jump to Subroutine

E 0250 JSR 1567

- 1567 - Start block of the subroutine

Subroutines can be called up at any time. The maximum permissible number of nested subroutines is 127.

A subroutine must end with the command "RTS" (program jumps back to the block following the JSR command). If an RTS command is not programmed at the end of a subroutine, the programmed lines following the end of the subroutine will be executed. This can result in unexpected axis movement, "Invalid Program Command" diagnostic, etc.

NOTE: Additional program flow control is possible by using the Change Subroutine Stack command (CST) with the JSR/RTS commands for advanced programming.

5.43 JST Jump and Stop

E 0260 JST 1678

- 1678 - Target Block Number

This command causes the program to jump directly to the target block. The CLM will issue a software command and stop the program, waiting in the target block for a new start impulse at system input "Cycle Start". The start impulse will cause the CLM to continue processing the program beginning with the target block.

A JST command executed in Task 1 will cause the program running in Task 2 to halt in its current block until a "Cycle Start" command is issued to restart the program.

5.44 JTK Jump in Task

E	0134	JTK
0100	1	

- 0100 - Target block
- 1
 - 1 = Task 1
 - 2 = Task 2
 - 3 = Task 3
 - 4 = Task 4
 - 5 = Task 5

The JTK command is used for initiating an Unconditional Jump within a selected task. This command terminates the current program sequence for the selected task and then causes it to jump to the target block. If the task is currently executing a move profile, the motion is completed before the task can be interrupted. If necessary, a PBK command can be used before the JTK to terminate the motion thereby providing an immediate interrupt. The JTK command permits the use of many specific interrupt routines trapped by numerous events.

NOTE: If only one (input dependent) interrupt routine is needed, it is recommended to use the interrupt parameter B012.

In most applications, the JTK command will be issued from one of the other tasks - typically one assigned a supervisory status. If used correctly, the JTK command can provide many of the functions available in B012 (Interrupt Vector) with the additional flexibility to use any event or series of events: position, count, one or more inputs or outputs to cause an interrupt to Task 1, 2 or 3.

- The command JTK_0100_2 in Task 1 causes the program to continue executing at Block 100 of Task 2.
- JTK can also be programmed in Task 3.
- JTK_0100_1 in Task 1 has the same meaning as JMP_0100!
- When this command is executed, Task 3 does not branch to any other target block.

5.45 KDI Copy Position Difference

E	0050	KDI	
0200	0100	1	

- 0200 - Target block for the stored position difference
- 0100 - Compare position block number
- 1 - (as of software version LA04V09)
 - 0 = Commanded position minus the compared position
 - 1 = Compared position minus the commanded position
 - 2 = Actual position minus the compared position
 - 3 = Compared position minus the actual position

The Compared Position is the difference between the Actual Absolute Position (LP Screen) and an Absolute Position at a specific program block (for example, block 0100 as shown above).

The KDI command will copy the position difference between the actual absolute position and the absolute position at a specific block number (Compare position block number). The compare position axis number and the position difference is then stored in the target block. The amount of time to process the KDI command can be up to 100 ms. The program will advance to the next block after the position difference is stored in the target block. The actual position is either subtracted from the compared position or the compared position is subtracted from the actual position.

In order for the KDI command to function properly, the following conditions must be met:

1. The appropriate Axis (1, 2, 3 or 4) must be homed. If the Axis is not homed when the KDI command is encountered in the program, then the error message "Axis (#1, 2, 3 or 4) Not Homed" is displayed.
2. The compare position block number must contain an absolute feed command (POA; PSA). If the program block is not an absolute feed, then the error message "Invalid Prog Cmd" will occur.
3. The target block must contain an incremental feed command (POI; PSI). If the target block is not an incremental feed, then the position difference is lost permanently.
4. The WRI command cannot be processed while using the KDI command.
5. The KDI command can only be used in one task at a time.

5.45.1 MLO Material Length Output

(as of software version LA04V07)

E 0025 MLO
010000.00 10 1

- 010000.00 - Material length in EGE
- 10 - Output
- 1 - Output ON/OFF
 - 0 = OFF
 - 1 = ON

During automatic operation, the MLO command allows an output to be turned ON/OFF based on the material length measured by the measuring wheel.

The first time the command is read in, the measurement feature is turned on. If the measurement is larger than the programmed value, the output is turned ON/OFF, depending upon the setting. The measurement starts over, and if the next measurement is larger than the programmed value, the output is turned ON or OFF again. Immediately after the command is read, the next program block is executed.

If the material length is programmed to 0, or if automatic operation is turned off, the measurement feature is turned off.

NOTE: If the material has already been measured when the MLO command is read, and the measurement is larger than the programmed value, the output is turned ON or OFF and measurement starts over.

5.46 NOP No Operation (Blank Block)

E 0270 NOP

This is the command to describe a blank block. During processing in the automatic mode, this blank block is scanned only: processing continues with the next block.

NOP's can be used to reserve program block space for future program change and expansion. Also use NOP's in the program where you may want to add commands "on the fly" to modify production.

NOP's may also be used as a program delay for each block. Note that the smallest delay programmable in the WAI command is 10 milliseconds. The NOP command allows for smaller increments of delay.

- If one or two axes are enabled, the default delay time for each NOP block is 2 milliseconds.
- If three axes are enabled, delay time is 3.0 milliseconds for each NOP block.
- If all four axes are enabled, delay time is 4.0 milliseconds for each NOP block.
- Note that these default delay times can be changed in parameter B015.

5.47 PBK Position Break

E	0055	PBK
1		

- 1 - Axis number (1, 2, 3 or 4)

The PBK command stops the execution of the current motion profile by decelerating the selected axis to a controlled stop. The selected axis will decelerate using the current programmed acceleration rate. The remaining distance to be traveled is ignored and the program jumps to the next block.

This command could be used in another task to control the actions of the selected axis.

NOTE: The KDI command could be used for storing the approximate remaining distance, otherwise the information is permanently lost.

5.48 POA Position Absolute

E	0280	POA
1	+12345.678	999

- 1 - Axis (1, 2, 3 or 4)
- +12345.678 - Plus or minus absolute target position in input units (to 2 or 3 decimal places, depending on the setting in B007)
- 999 - Feed rate in % (00.1-99.9) of the maximum velocity set in the parameters.

The specified axis must be homed (HOM or CLA) prior to execution of this command. Otherwise, an error message will be issued. Stepping to the next block takes place immediately after the absolute position has been read into the position buffer. Since this command does not wait for the axis to be in position before jumping to the next block, the program command following this command will be executed. This allows other functions and status to be executed while the axis is moving toward the end position.

If multiple POA commands are in sequence, the resulting move will, in most cases, continue and stop at the last POA Target Position issued.

An ATS command programmed in a subsequent block to monitor the Position Tolerance Output (Parameter Ax06) or the Position pre-signal (Parameter Ax07) is useful in controlling when to step to the next block.

5.49 POI Position Incremental

E 0290 POI
2 +12345.678 999

- 2 - Axis number (1, 2, 3 or 4)
- + - Incremental feed direction (+ or -)

NOTE: If a character other than "+" is entered for this digit the feed direction will be minus.

- 12345.678 - Incremental feed length in input units (to 2 or 3 decimal places, depending on setting in B007)

999 - Feed rate in % (00.1 - 99.9) of the maximum velocity set in the parameters

Example: 500 would be 50.0% of the maximum velocity.

Stepping to the next block takes place immediately after the feed block has been read in.

Since this command does not wait for the axis to be in position before jumping to the next block, the program command following this command will be executed. This allows other functions and status to be executed while the axis is moving toward the end position.

If multiple POI commands are in sequence, the resulting move will be the sum of all incremental feeds.

The ATS command programmed to monitor the Position Tolerance Output (Parameter Ax06) or the Position pre-signal (Parameter Ax07) is useful in controlling when to step to the next block.

5.50 POM Position On Memory

E	0300	POM
3	0	0

- 3 - Axis Number (1, 2, 3 or 4)
- 0 - Mode
 - 0 = Feed incremental
 - 1 = Feed in absolute dimensions
- 1 - Feed direction
 - 0 = Positive
 - 1 = Negative

The POM command is an incremental or absolute positioning command. The programmed feed length and velocity are stored in a single memory location by either Indramat IDS decade switch option, or by multiplexing a set of inputs (see program command SO1). Note that any axis can be controlled by the POM command, but given a single memory location, only one value can be stored at one time.

Stepping to the next block takes place immediately after the POM command is read into the program.

When using the IDS decade switch, enable this option in Parameter B003. If the decade switch option is not enabled, this block is scanned and no positioning takes place.

5.51 PSA Position Absolute (With In-Position Signal)

E	0310	PSA
1	+12345.678	999

- 1 - Axis number (1, 2, 3 or 4)
- +12345.678 - Plus (+) or minus (-) absolute target position in input units (to 2 or 3 decimal places, depending on the setting in B007)
- 999 - Feed rate as % (00.1 - 99.9) of the maximum velocity set in parameters

NOTE: The axis must be homed prior to execution of this command. Otherwise, an error message will be issued.

Stepping to the next block takes place only after the positioning has been completed. Parameter Ax06 (Position Tolerance) is used to set the release point for stepping to the next block.

5.52 PSI Position Incremental (With In-Position Signal)

E 0142 PSI
2 +12345.678 999

- 2 - Axis number (1, 2, 3 or 4)
- + - Incremental feed direction, plus (+) or minus (-)

NOTE: If a character other than "+" is entered for this position, the feed direction will be negative.

- 12345.678 - Feed length in input units (to 2 or 3 decimal places, depending on setting in B007)
- 999 - Feed rate as % (00.1 - 99.9) of the maximum velocity set in parameters

Stepping to the next block takes place only after the positioning has been completed. Parameter Ax06 (Position Tolerance) is used to set the release point for stepping to the next block.

5.53 PSM Position On Memory (with In-Position Signal)

E	0330	PSM
3	0	1

- 3 - Axis Number (1, 2, 3 or 4)
- 0 - Mode
 - 0= Feed incremental
 - 1= Feed in absolute dimensions
- 1 - Feed direction
 - 0 = Positive
 - 1 = Negative

The PSM command is an incremental or absolute positioning command with position acknowledgment. The programmed feed length and velocity are stored in a single memory location by either Indramat IDS decade switch option, or by multiplexing a set of inputs (see program command SO1). Note that any axis can be controlled by the PSM command, but given a single memory location, only one value can be stored at one time.

Stepping to the next block takes place after positioning is complete. The "In Position" aux. output is programmed in Parameter Ax06 - Position Tolerance.

When using the IDS decade switch option, enable this option in Parameter B003. If the decade switch option is not enabled, this block is scanned and no positioning takes place.

5.54 PST Position Test

E	0340	PST
1	05	+12345.678

- 1 - Axis number (1, 2, 3 or 4)
- 05 - Auxiliary output number
- +12345.678 - Test position value (to 2 or 3 decimal places, depending on setting in B007)

This command is used to check for a position and control an output based on current position status. At the execution of this block, the designated auxiliary output is turned ON if the actual position of the axis is less than the test position value.

If the actual position is equal to or greater than the test position value, the auxiliary output is turned OFF. Stepping to the next block takes place immediately after the block has been read in. Please note that the position is only tested once during the execution of the PST block. A program loop must be created to test for a position repeatedly.

NOTE: PST only functions after the axis has been homed. Prior to this, the block is scanned only and no execution takes place.

5.55 REF Referencing (Detect Registration Mark Input)

E	0350	REF
2	0	123 01

- 2 - Axis number (1, 2, 3 or 4)
- 0 - Direction
 - 0= forward
 - 1= reverse
- 123 - Search speed in % (00.1 - 99.9) of the maximum velocity set in parameters
- 01 - Registration auxiliary input number

NOTE: If the value 00 is entered here, possible only for axis 1, then system input 16, connector X3, pin 16, must be used. This is a high speed input, which makes possible a much more precise detection of the reference mark.

CAUTION: If the high speed input option is selected, then measuring wheel operation is not possible. Connector X1 must have the following pins bridged -- 5 to 13, 6 to 14, 7 to 15, and 8 to 16.

It is possible at any time to search for a registration (reference) mark. The axis, direction, search speed (velocity) and registration input number can be freely selected. After the start of the block, the axis moves at the specified search speed until a positive edge occurs at the specified aux. input. Stepping to the next block takes place only after the reference marker has been found (unless the next block is a REP command, see page on REP command).

When the registration mark is found, the axis is decelerated and travels in reverse to the position the registration mark was detected at. If it is desired that the axis does not back up in this manner, the REF (or REF/REP) can be followed by a PSI command. The PSI feed length would be set to the distance it takes to decelerate the axis from the search speed.

The CLM includes two auxiliary high speed inputs for this function (selected as auxiliary input 98 or 99). This input must be wired to a high speed sensor which will detect a printed mark or stamp on each section or piece of material being fed (signal duration of at least 150 microseconds). Signal duration for other auxiliary inputs must be at least 2-4 milliseconds.

NOTE: At the time of this revision, these auxiliary high speed inputs are not fully implemented. Check with an Indramat Application Engineer for current status before using.

5.56 REP Registration Position Limit (Search Limit Branch)

E 0351 REP 0100 4 12345.678
--

- 0100 - Target block number (0000-2999), if search path exceeded
- 4 - Axis number (1, 2, 3 or 4)
- 12345.678 - Maximum search path for REF command (to 2 or 3 decimal places, depending on setting in B007)

The REP command is used to limit the maximum search distance while looking for the registration input. It will cancel a registration search command REF, and jump to the target block. REF and REP are run simultaneously; the REP command cannot be run by itself.

At the start of the REF/REP commands, the axis moves at the search speed until either the registration mark is detected, or the search length has passed.

If the registration mark is not detected, the axis will be decelerated to a stop after the search length occurs. The actual length traveled will be the search length plus the distance it takes to decelerate the axis to a stop. A jump is executed to the target block at the end of the search length, as the axis starts decelerating.

If the registration mark is detected, the axis is decelerated (as described for the REF command) and stepping to the next block takes place.

The target block should be the start of a recovery routine written to restore operation from a missed mark. It will need to be customized for each application.

5.57 RMI Registration Mark Interrupt

```

E 0300 RMI
0 01
    
```

This command can be used to initiate additional processing, independently of the feed program. The additional registration mark processing is initiated after the recognition of an input pulse, and after an offset has been traversed. The startup signal edge of the pulse is evaluated. The feed program is interrupted for this registration mark processing and subsequently continued.

- 0 - Mode
 - 0 = Wait for pulse at the registration mark input (stepping to the next block takes place after recognition of the pulse and traversing the offset.)
 - 1 = Terminate registration mark processing continue feed program. (stepping to the next block takes place immediately)
- 01 - Registration mark input
 - 0 = quick input (system input 16, connector X3, pin 16), recognition in approx. 100 usec.
 - 01-16 = standard input (recognition in approx. 2 msec)

The registration mark program has to be programmed in Task 2. An offset can be programmed in the form of an incremental feed (POI, PSI, POM, or PSM). The incremental feed command has to follow the RMI command directly.

Example of application:

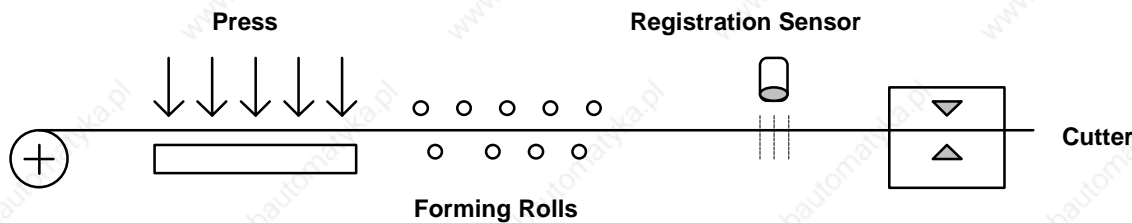

Perforated sheet metal should be cut according to the location of the perforations, which are stamped into the flat sheet metal on the press. The material is then fed through the forming rolls. A hole serves as a reference signal for recognition of the registration sensor. Since an unknown change of length occurs during profiling, the same feed program cannot be used for the cutting process because of the possibility that the perforation will drift to the edge cannot be excluded. Because of this reason, cutting is done depending on the reference hole.

The reference hole can be detected by means of a light barrier, initiator, or similar device.

NOTES:

- Possible only with Axis 1; not usable with an adjusting axis or a motor with reversible poles.
- Not usable with synchronous axis, in accordance with parameter 46 = 03XXXXXX
- Cannot be used simultaneously with a REF command for Axis 1
- Will be ignored in the case of re-start
- The RMI works correctly only with feeds and offset feeds in positive direction (e.g., PSI 1 +....)
- In Task 2, (RMI program) there should be not other feed except for the offset
- After the RMI command (RMI 0 XX) has been called up, masking a hole is no longer possible
- Recognition of an additional registration mark prior to the command 'RMI 1 XX' is not possible

The velocity that can be changed by means of the offset feed is returned to its old value when the feed program resumes. The interruption, feed monitoring and override functions may be used.

Sample program:

Task1:	PSI 1 +000050.00 999	
	JSR stamp1	
	PSI 1 +000025.00 999	
	JSR stamp2	
	JMP task1	
Stamp1:	AEA 01 1	stamping with stamp 1
	WAI 00.20	
	AEA 01.00	
	RTS	
Stamp2:	AEA 02 1	stamping with stamp 2
	WAI 00.20	
	AEA 02 0	
	RTS	
Task2:	RMI 0 00	wait for resistration mark
		pulse and traversing of offset distance
	PSI 1 +000015.50 500	offset distance from position of registration mark
	JSR tool	
	RMI 1 00	
	JMP task2	
Tool:	AEA 03 1	cutter on
	WAI 00.25	waiting time
	AEA 03 0	cutter off
	WAI 00.20	waiting time
	RTS	

5.58 RSV Restart Vector

E	0700	RSV
1	000	10000

- 1 - Restore status as before interrupt, except outputs
- 000 - Not used, set to 000
- 1 - Outputs status
 - 0 = Restore status of outputs as before interrupt
 - 1 = Do not restore outputs
- 0000 - Not used, set to 0000

The Restart Vector is used to recover for a power loss, System Error or change in mode from Auto to Manual. When any of these events occur, the status at the time (velocity, absolute target position, outputs, etc.) are temporarily stored and can be recovered with this command. Use this command only if the system has an absolute encoder.

NOTE: The temporarily stored absolute target position will only be resumed if the corresponding axis is equipped with an absolute encoder.

5.59 RTM Rotary Table Mode

E	0000	RTM
1	1	

- 1- Axis number (1, 2, 3 or 4)
- 1- Rotary Table Mode:
 - 0 = set to mode designated in Parameter Ax10
 - 1 =
 - 2 = programmed direction
 - >2 = no mode change

The selected axis must be enabled and completely set up via parameters, or an error message will result.

After restarting, clearing a fault, or exiting Parameter Mode, the settings from Parameter Ax10 are valid. Toggling between Manual and Automatic modes does not affect the current Rotary Table Mode.

5.60 RTS Return from Subroutine

E 0370 RTS

The RTS command is used to return from a subroutine which has been called by using the JSR command. The program is continued at the point where the subroutine had been called which is the next block after the JSR command.

If in multiple subroutines, the RTS command will take the program back only to level of the current subroutine stack.

NOTE: Additional program flow control is possible by using the Change Subroutine Stack command (CST) with the JSR/RTS commands for advanced programming.

5.61 SAC Set Absolute Counter

E	0300	SAC
1 0	+12345.678	

- 1 - Axis number (1, 2, 3 or 4)
- 0 - 0 = Absolute offset (offset change)
 - 1 = Set absolute position with respect to the command position.
 - 2 = Set absolute position, with respect to the actual position.
- +12345.678 - Absolute position or offset, plus (+) or minus (-)

This command is used to set or change the value of the absolute position counter. The axis must be homed before this command can be used.

5.62 SIN Sine Oscillation

E	0380	SIN
1	10	12.345 999

- 1 - Axis number (can only be axis 1 or axis 2)
- 10 - Auxiliary input which enables SIN function
- 12.345 Amplitude in Input Units (to 2 or 3 decimal places, depending on setting in B007)
- 999 - Frequency of oscillation in Hertz (0.01 to 9.99)

This function will start up with 0 degrees when the enable input is switched On. When the enable input is switched Off, the function ends at 360 degrees. After this, stepping to the next block will take place. The axis must be homed, or an error will occur when this command is read.

5.63 SO1 Scanning of Inputs and Modifying a Length (Special Option #1)

```
E 0320 S01  
1 1 10 1000
```

- 1 - 0 = read decade switch values
 - 1 = Convert decade switch values into Position and store this in the position section of the POI, PSI, POA and VCC commands.
 - 2 = Convert decade switch values into Velocity and store this in the velocity section of the POI, PSI, POA and VCC commands.
- 1 - Decimal Position (Y value): (to 2 or 3 decimal places, depending on setting in B007)

For 3 decimal places

For 2 decimal places

- 1= 10^{-3}
- 2= 10^{-2}
- 3= 10^{-1}
- 4= 10^0
- 5= 10^1
- 6= 10^2
- 7= 10^3
- 8= 10^4

- 1= 10^{-2}
- 2= 10^{-1}
- 3= 10^0
- 4= 10^1
- 5= 10^2
- 6= 10^3
- 7= 10^4
- 8= 10^5

- 10 - Starting Input Number XX, with the BCD value (see illustration):

XX = 10
XX+1 = 11
XX+2 = 12
XX+3 = 13

- 0000 - Target Block

Command Type	Mode 1	Mode 2
POA, POI, PSA, PSI	Position	Velocity
VCA, VCC	Position	Velocity
ACC	Acceleration	-----
BAC, COU	-----	Command Quantity
BPT, BZP	Position	-----
CON as of sw LA01.3-3.3	-----	Velocity
CID as of sw LA01.3-3.3	-----	Information
PST	-----	Position
SAC as of sw LA01.3-3.0	Position	-----
SIN as of sw LA01.3-04V07	Amplitude	Frequency
WAI as of sw LA01.3-3.3	Time	-----

The target block must contain one of the commands listed in the table above. Decade switch IDS-01 can be used simultaneously.

The SO1 command is used to read length information, via decade switches or from a programmable logic controller.

In the following example, aux. input 10 is the least significant digit. Enter 10 for the XX entry. Input 11 is 10+1 (XX+1). Input 13 is the most significant digit (XX+3). The CLM must read in all decimal places, one after the other. An SO1 command is required for each decimal place. The resulting information is converted to position and velocity, and stored in one of the following position commands (POI, PSI, POA, PSA, VCC) programmed in the target block.

The information is zeroed after a fault, Emergency Stop, enabling of Parameter Mode, or powering up the CLM system.

The illustration is an example of an external decade switch group connection (4 decade).

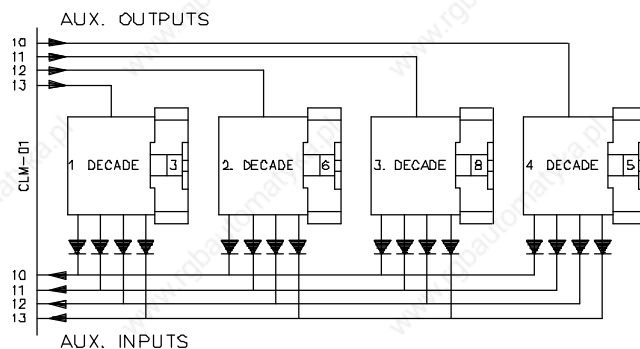

The following example program, using the SO1 command, uses APE command to switch outputs.

BLOCK#/COMMAND/COMMAND DATA

0900	APE	1 1000222222	= Fourth Decade (10^{-1})
0901	WAI	00.02	
0902	SO1	0 2 10 0100	
0903	WAI	00.02	
0904	APE	1 0100222222	= Third Decade (10^{-0})
0905	WAI	00.02	
0906	SO1	0 3 10 000	
0907	WAI	00.02	
0908	APE	1 0010222222	= Second Decade (10^1)
0909	WAI	00.02	
0910	SO1	0 4 10 0100	
0911	WAI	00.02	
0912	APE	1 0001222222	= First Decade (10^2)
0913	WAI	00.02	
0914	SO1	0 5 10 0100	
0915	WAI	00.02	
0916	SO1	1 5 10 0100	= Read in as Length

The fourth decade is read in via output 10, the third via output 11, the second via output 12, and the first via output 13. In the example, inputs 10 to 13 are programmed as an input. The length is then read in.

NOTES:

- It is useful to program this type of decade switch query in Task 3.
- All numbers which are not read in (pseudo-nibbles) are assumed to be 0.

5.64 SO2 Position Correction Via Analog Input

E	0045	SO2
1	+123.456	2

- 1 - axis selection
 - 1 = axis 1 and analog input AE1
 - 2 = axis 2 and analog input AE2
 - 3 = axis 3 and analog input AE3
 - 4 = axis 4 and analog input AE4
- + - prefix of the stroke
 - (+) = positive stroke with positive voltage and negative stroke with negative voltage
 - (-) = negative stroke with positive voltage and positive stroke with negative voltage
- 123.456 - stroke between 0 volts and 10 volts, in input units (the voltage range of -10 V to +10V corresponds to 2 * stroke)
- 2 = command mode: 0 to 4

Description of command mode options:

- 0 = a) preparation for mode 2. The current absolute position becomes zero position for mode 2
b) End of mode 4
- 1 = One time feed (with POI) = stroke * voltage / 10 (feed length increased/decreased)
- 2 = Absolute feed with respect to the zero position (set in mode 0). Zero volts at the analog input positions the axis onto zero.
One time feed (with POA) = (stroke- zero position) * voltage / 10
- 3 = One-time feed = stroke * voltage / 10 (feed is set)

This command must be called up again and again in a loop for purposes of control. An external measuring device provides a voltage of +/- 10 V, proportional to the path traversed. Positioning on the zero position of the measuring device then takes place, i.e., to 0 volt => corresponding to the command value control.

- 4 = Startup of the position detection via the analog input. This function is always active until it is shut down by mode 0. Traversing within the range "-stroke" to "+stroke" can be done now with an absolute travel command.

NOTES:

- In modes 2 and 4, the axis must have been set up, otherwise, there will be a corresponding error message 'Axis Not Homed'.
- Mode 4 is not cleared when the operating mode changes from automatic to manual or from manual to automatic; however, it is cleared in case of fault, emergency shutdown, and startup.

Example entries/results:

Entry:

```
E 0045 SO2
1 +002.000 1
```

Result:

<u>Voltage at AE 1</u>	<u>Position Correction Value</u>
+ 10 V	+ 2.000
+ 5 V	+ 1.000
0 V	0.000
- 3 V	- 0.600
- 10 V	- 2.000 STH Send to Host

```
E 0390 STH
0 0002
```

- 0 - Type of information
 - 0 = Status 00, 02, 03, 05, 06, 07, 08, 09, 48, 48, 50, 51, 52 (See Chapter 7)
 - 1 = Counter status of preset and actual number of pieces. The block number of the counter must be entered in the status code field.

- 0002 - Code for Status, options as below:
 - 0000 = Actual position of each axis
 - 0002 = Current program block number
 - 0003 = Actual position as a hexadecimal value
 - 0005 = Software version description
 - x006 = Current input state
 - x007 = Current output state
 - 0008 = Current Block (Task 1, 2, 3)
 - 0009 = Measuring Wheel
 - 0048 = Velocity in RPM (axis 1, 2, 3 and 4)
 - 0049 = Voltage Analog Inputs 1, 2, 3 and 4
 - 0050 = System inputs and system outputs as a hexadecimal value
 - 0051 = Auxiliary inputs as a hexadecimal value
 - 0052 = Auxiliary outputs as a hexadecimal value

NOTE: In x006 and x007, x = Input/output bank number, 0-9

Program-controlled data output via the serial interface (see Chapter 7). Stepping to the next block takes place immediately after the block has been read in. Serial interface must have been activated through parameters B003 and B004. Otherwise, stepping to the next block takes place without having an output transmitted.

Examples of STH entry:

0__0003_____

Status `03' actual position of axis 1 and 2 in Hexadecimal, is transmitted to Host device via the serial interface.

1__0100_____

Status of counter located in block 0100. The desired and actual number of pieces, is transmitted to Host device via the serial interface.

NOTE: Status Messages are processed in the background of the program. Since this has a lower priority, the exact time of execution (and transmission) are not easily calculated.

5.64.1 STO Send Information To Outputs

E	0002	STO
101	1	3 0000 05

- 1 - Axis number or general data
 - 0 = Counter status
 - 1-4 = Axis 1-4
- 0 - Not used, set to 0
- 1 - Information type
 - 1 = Absolute position
 - 2 = Counter status
- 1 - Mode
 - 0 = Store current information (position or counter)
 - 1 = Output stored information via outputs in BCD format
- 3 - Decimal position

Decimal	Significance
1	1st digit starting from the right
2	2nd digit starting from the right
3	3th digit starting from the right
4	4th digit starting from the right
5	5th digit starting from the right
6	6th digit starting from the right
7	7th digit starting from the right
8	8th digit starting from the right
9	9th digit is prefix; + = 0 - = 1

For the prefix, 24V is output for minus, and 0V is output for plus.

- 0000 - Block number (save if in counter)
- 05 - Starting output number XX (otherwise 00):
 - XX = 10 corresponding value $1 = 2^0$
 - XX+1 = 11 corresponding value $2 = 2^1$
 - XX+2 = 12 corresponding value $4 = 2^2$
 - XX+3 = 13 corresponding value $8 = 2^3$

The STO command is used to output either axis position or counter status information via four auxiliary outputs in BCD format. The user specifies the type of information, number of decimal places, counter block (if counter status is selected), and the starting output number. The three outputs after the starting output number will be used to output the information.

The commands are processed as follows:

- Mode 0 Store information in internal buffer, then
- Mode 1 Output information

Only one type of information can be stored internally at one time, either absolute position or counter status. The buffer is never zeroed by the CLM.

STO Command Example:

For this example, the absolute position for the axis is equal to +598.00 inches. The auxiliary outputs 04 through 07 are used for the BCD value.

```

0900  AKN  02   0           ; Toggle input #2 to begin the program
0901  AKN  02   1

0902  STO   1 1 0 0 0000 00 ; Store actual position
0903  JSR   0925           ; Jump to subroutine at program block 0925
0904  STO   1 1 1 9 0000 04 ; Output the direction of the sign
0903  JSR   0925           ; Jump to subroutine at program block 0925
0906  STO   1 1 1 3 0000 04 ; Output third digit
                                ; ( XX+3=1, XX+2=0, XX+1=0, XX=0) = 8

0907  JSR   0925           ; Jump to subroutine at program block 0925
0908  STO   1 1 1 4 0000 04 ; Output fourth digit
                                ; ( XX+3=1, XX+2=0, XX+1=0, XX=1) = 9

0909  JSR   0925           ; Jump to subroutine at program block 0925
0910  STO   1 1 1 5 0000 04 ; Output fifth digit
                                ; ( XX+3=0, XX+2=1, XX+0 =0, XX=1) = 5

0911  JSR   0925           ; Jump to subroutine at program block 0925
0912  STO   1 1 1 6 0000 04 ; Output sixth digit
                                ; ( XX+3=0, XX+2=0, XX+0 =0, XX=0) = 0

0913  JMP   0900           ; Jump to program block 0900 and start a new read in
                                ; the cycle

0925  AKN  01   0           ; Toggle input #1 to output the next digit
0926  AKN  01   1
0927  RTS                               ; Return from subroutine

```

5.65 VCA Velocity Change Absolute

```

E 0410 VCA
2 +12345.678 100
    
```

- 2 - Axis number (#1 or 2 only)
- +12345.678 Absolute position to be reached before the velocity change (to 2 or 3 decimal places, depending on the setting in B007)
- 100 - Speed in % (00.1 - 99.9) of the maximum velocity set in the parameters

The VCA command is used to alter the current rate of velocity at some point along a path. Multiple VCA commands can be used to create a "step" effect in the velocity profile. Stepping to the next block takes place after the absolute position has been reached.

This function is designed to work in conjunction with the position commands POA, POI, and POM.

Example:

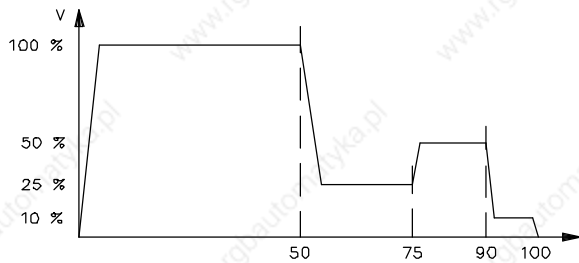

```

0000 POA 1 +00100.000 999
0001 VCA 1 +00050.000 250
0002 VCA 1 +00075.000 500
0003 VCA 1 +00090.000 100
0004 ATS 15 1
0005 WAI 01.00
0006 POA 1 +00000.000 999
0007 VCA 1 +00090.000 100
0008 VCA 1 +00075.000 500
0009 VCA 1 +00050.000 250
0010 ATS 15 1
0011 JST 0000
    
```

5.66 VCC Velocity Change Command

E	0410	VCC
2	12345.678	100

- 1 - Axis number (1, 2, 3 or 4)
- 12345.678 Path to be traversed before the velocity change (to 2 or 3 decimal places, depending on the setting in B007)
- 100 - Speed in % (00.1 - 99.9) of the maximum velocity set in the parameters

The VCC command is used to alter the current rate of velocity at some point along a path. Multiple VCC commands can be used to create a "step" effect in the velocity profile. Stepping to the next block takes place after the path specified in the VCC command has been traversed.

This function is designed to work in conjunction with the position commands POA, POI, and POM.

NOTE: If the path specified here is longer than the previous position command, the CLM will step to the next block after the axis reaches position tolerance (see Parameter Ax06).

Example:

```

0000 POI 1 +00010.000 999
0001 VCC 1 +00050.000 250
0002 VCC 1 +00075.000 500
0003 VCC 1 +00090.000 100
0004 ATS 15 1
0005 WAI 01 .00
0006 JST 0000

```

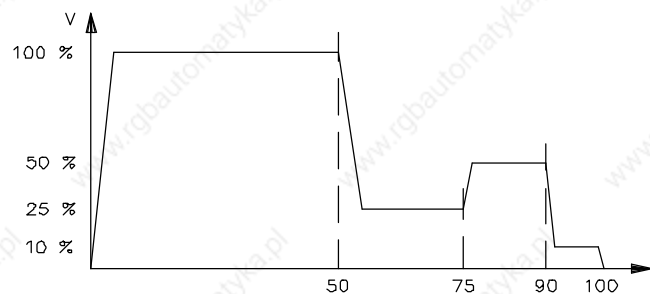

5.67 VEO Velocity Override Command

E	0400	VEO
1	2	3 456 7

- 1 - Axis number (1, 2, 3 or 4)
- 2 - Override input selection
 - 0= switched OFF or override in accordance with Parameter B008
 - 1= Override via potentiometer at analog input - AE1 for axis 1, AE2 for axis 2, AE3 for axis 3, AE4 for axis 4.
- 2 = Override via Binary value at Inputs #8-16, Significance = input 8:2⁰, input 9:2¹, input 16:2⁷
- 3 = Override via value in Gray Code in inputs #13-16 (as in B008)
- 4 = Programmed Override (requires entry 456-Velocity)
- 5 = Axis velocity is determined by the pulse frequency of the measuring wheel encoder
- 6 = Analog input 1 × Override Value (as of software version LA04V07)

Override selection '5' can be activated with the VEO command only if '2xxxxx' is programmed in Parameter B008. Parameters B009 (only the number of pulses) and B010 must also be programmed.

The feed constants and the number of lines of the motor encoder and of the measuring wheel encoder are taken into account in such a way that, at a feed rate of 100 % velocity, both mechanisms (axis and measuring wheel) are running at the same velocity. This velocity can be determined by means of the synchronizing factor with the command FOL.

If axis 1 should achieve a velocity of more than 1.25 times V_{max} due to incorrect programming or because of excessive velocity of the measuring wheel, the following error message will be displayed:

Error

maximum override A1 (error number: 4D hex)

The velocity of axis 1 limited in all instances to V_{max} in case measuring wheel velocities exceed V_{max}.

- 3 - Override update
 - 0 = Read the Override input value every program cycle (time depends on the number of axes enabled and user settings, see parameter B015)
 - 1 = Reads Override value only once (each time the command is executed)

- 456 - Velocity factor to 3 decimal places (.001-.999). This factor is significant only if '4' is selected in the second digit. Subsequent feeds are reduced by this factor.
- 7
 - 0 = Override input value represents a factor to determine the resulting velocity. All subsequent feeds will be scaled.
 - 1 = Override input value represents a limiting factor. Position commands that have a lower velocity than this are not affected.

The VEO command is used to override programmed velocity by several means.

The override via the analog input is typically used with a master potentiometer mounted on the control panel, to provide the operator a means to speed up or slow down a process.

The Binary or Gray scale might be used in conjunction with a PLC.

The limiting sector is typically a internal software switch in the user program.

Programmed override is a means of scaling or limiting the velocity of the subsequent process after the command is read and will remain in effect until it is changed.

5.68 WAI Wait (Time Delay)

```
E 0420 WAI  
00.50
```

- 00.50 - Dwell time (00.01-99.99 seconds)

Examples of how a time delay is programmed:

- 00.01 = 10 milliseconds (the minimum dwell time programmable),
- 00.50 = 0.5 seconds.

The CLM waits in the program block until the specified time has elapsed. After the time delay, the program steps to the next block. See the NOP command for related function (when require less than 10 milliseconds dwell time).

5.69 WRI Write in Absolute Position (Teach Command)

E 0042 WRI 0357 002

- 0357 - Target block number
- 00 - Command type
 - 00 = save command position
 - 01 = save actual position
- 2 - Axis number (1, 2, 3 or 4)

Use this command to "write in" (teach) an absolute positioning command in the user program. Note that an absolute positioning command requires that the selected axis **MUST BE HOMED**. Otherwise, an "Axis Not Homed" error occurs.

When the WRI command is read, the current absolute position or the command position is saved in the target block as the positional indication. One of the following commands must already be programmed in the target block: POA, PSA, VCA, BPT, BZP, PST or SAC. The previous position indication in the target block is overwritten by the WRI command.

The next block is executed when the position is saved in the target block.

The last digit specifies which axis (1, 2, 3 or 4) the absolute feed command controls.

This command is used to teach or update a position into a functional program. The axis is typically jogged into a desired position, then a predefined teach routine is run that will teach this position into all the appropriate blocks. The teach routine can be written as a manual vector or as program for Task 1, 2 or 3.

The absolute feed command selected by the WRI command must have a distance to feed. This distance is taken from the Actual Position Display. The speed automatically inserted for doing the feed is always the maximum (99.9%). A preceding VEO (selection 4) or subsequent POI (zero feed length) can be used to reduce the written velocity to a lower percentage.

Using the WRI command in Manual Mode

This is an example of how to "write in" absolute positions in the main program.

Task 3 is selected as the location for the WRI command. The Task 3 program must be loaded into the CLM before enabling parameter B006. Task 3 is always running, even before Cycle Start is pressed. All errors stop Task 3, except for E-Stop conditions.

Start Task 2&3

Parameter B006 00000150

NOTE: Axis must be homed.

Example: Program for the WRI command.

```
0150      AKN 02 1   Aux input #2 "writes in" 1st position
0151      BCA 0150 15 0   Check axis 1 is homed
0152      BCA 0150 16 0   Check axis 2 is homed
0153      WRI 0015 001   Writes in Abs. Position at Block 0015
0154      WRI 0016 012   Writes in Abs. Position at Block 0016
0155      AKN 02 0   Write-in complete
0156      AKN 02 1   Aux. Input #2 "writes in" 2nd position
0157      WRI 020 001   Writes in Abs. Position at Block 0020
0158      WRI 0021 012   Writes in Abs. Position at Block 0021
0159      AKN 02 0   Write-in complete
0160      JMP 0150      Jump to Block 0150
```

Example: Main Program Before It "Writes In" the New Position

```
0000      JMP 0015
0015      PSA 1 +00000.000 500
0016      PSA 2 +00000.000 500
0017      AEA 01 1
0018      WAI 00.50
0019      AEA 01 0
0020      PSA 1 +00000.000 500
0021      PSA 2 +00000.000 500
0022      AEA 02 1
0023      WAI 00.50
0024      AEA 02 2
0025      JMP 0015
```

Procedure for Using the WRI Command in Manual Mode

1. In Manual mode, home Axis 1 and 2.
2. Jog Axis 1 and 2 to the first position desired.

Example:

First position desired: L P 1A +00010.000
2A -00020.000

3. Turn Auxiliary Input #2 on and off.
4. Jog Axis 1 and 2 to the second position desired.

Example:

Second position desired: L P 1A -00005.000
00012.000

5. Turn Auxiliary Input #2 on and off.
6. Now blocks 0015 and 0016 should change to the first position desired. Blocks 0020 and 0021 should change to the second position desired.

Example: Main Program After It "Writes In" the New Position Block Number

```
0015      POA 1 + 00010.000 999
0016      PSA 2 - 00020.000 999
0017      AEA 01 1
0018      WAI 00.50
0019      AEA 01 0
0020      POA 1 - 00005.000 999
0021      PSA 2 +00012.000 999
0022      AEA 02 0
0023      WAI 00.50
0024      AEA 02 1
0025      MP 0015
```

6. INSTALLATION/START-UP

This Chapter covers the installation and initial start up testing procedures for the CLM control system. The system consists of the following components:

- The CLM Control Module
- The Servo Amplifier(s)
- The Power Supply
- The Servomotor(s)

The instructions in this chapter primarily describe the installation of the CLM Control Module. The installation particulars of the other components (such as a TVM or KDV power supply, and TDM or KDS servo amplifiers) are explained in detail in their respective manuals. Appendix B list relevant publications which you may require.

Tools required:

- A small 1/8" blade, standard screwdriver
- A multi-meter (VOM)
- An appropriate wrench for 1/4" machine type bolts (use for mounting module[s] to cabinet).

6.1 Unpacking / Parts Inventory

The CLM system is shipped in reinforced cardboard cartons and is sufficiently packed to withstand normal shipping activity. Upon receiving equipment, inspect shipping carton for any evidence of external damage (i.e., ripped or punctured carton, water marks, etc.). Should carton show any signs of damage, immediately inspect contents and contact carrier for damage claim if necessary.

Open cartons and remove the Styrofoam and bubble packing material from around the equipment. Remove the equipment and place on a firm level surface.

The CLM carton contains the following items:

- The CLM module
- CLM cable set (SK5001) contains:
 - 1 Input cable
 - 1 Output cable
 - 1 Encoder cable
- CLM Electrical Accessory Kit (E15-CLM) which contains:
 - 15 pin Phoenix connector (X5)
 - Wire tie wraps
 - 7 pin Phoenix connector (X7)

CLM optional equipment includes:

- Remote Keypad - accessories include:
 - Remote keypad extension cable (typically 2 meters)
 - 2 dual side adhesive foam gaskets for keypad
 - A dummy CLM face plate
- IDS Assembly - with Electrical accessory kit that contains:
 - A 5 pin Phoenix connector
 - A serial interface cable with a RS-232 connector at one end and Ferrule connectors on the other.

6.2 Mounting Cabinet

The CLM and its associated modules are designed for cabinet mounting. It is recommended the CLM be mounted in a cabinet, side by side with the Amplifier and Power Supply modules (see Figure 6.1). The enclosure should be sufficient to protect the equipment from contaminants, such as water, oil, etc. Indramat recommends a NEMA 4 or 12 enclosure or equivalent.

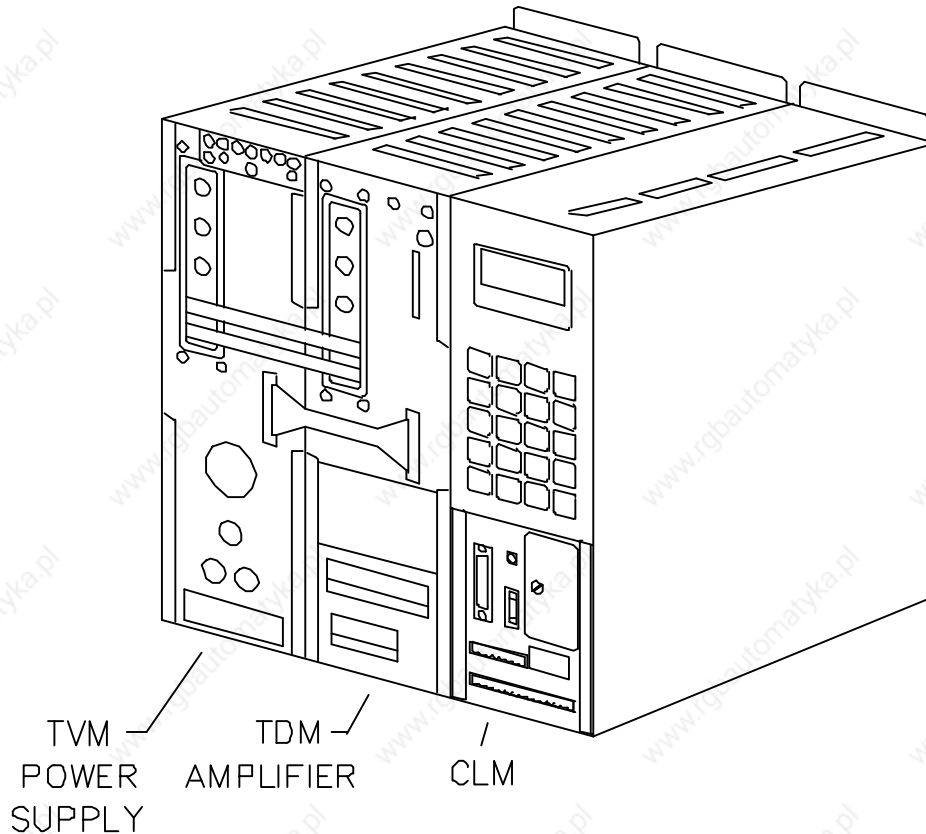

Figure 6-1 CLM System Modules

6.3 Power

The CLM requires 24 Vdc to operate. This voltage is supplied from the TVM (KDV) or from an external 24 Vdc supply. Refer to section 1.6.2 for power specifications for the CLM and its options. Refer to separate manuals (listed in Appendix B) for power requirements of the other modules (power supply, servo amplifier, etc.).

6.4 Cable Routing

For higher reliability, the feedback cables must be shielded and routed away from high voltage power sources to reduce electrical noise.

Do not route the CLM cables near high amperage type machines, like welding equipment, which produce strong magnetic field interference.

Suppress inductive loads (such as solenoids and motors) that are switched ON and OFF during CLM operation, with R-C networks (AC) or diodes (DC).

Correct grounding is essential for trouble free operation. The ground connection must be made by observing strictly the branching conditions shown in the wiring diagram.

6.5 Transformer - Heat Dissipation

The incoming 3-Phase power must be ground referenced. Use an isolation transformer with a "Y" secondary if this cannot be confirmed. Refer to TVM/KDV (or appropriate) manual for additional information.

If a transformer is needed for operation, exercise caution on its location. Do not install the transformer in the same cabinet as the CLM modules unless a sufficient method of cooling is applied.

6.6 Hardware Installation

The CLM and its supporting modules mount to the back wall of the equipment enclosure (cabinet). The mounting brackets of the modules are pre-drilled to accept a 1/4" machine bolt.

See Appendix G for mounting hole dimensions and location of the CLM module, the cut-out dimensions for the remote keypad, keypad gasket, and keypad replacement panel (dummy face plate), and mounting holes and cut-out dimensions for the optional IDS.

The mounting dimensions and cabinet cut-out data for the TVM (KDV) and the TDM (KDS) are located in the units respective support manuals.

The method of mounting the MAC servomotor is dependent upon the application. Additional information and a drawing package for the MAC servomotor is available on request from Indramat.

6.7 Electrical Installation

There are many variations of wiring techniques used to connect the CLM to the machine builder's equipment. The Interconnect Drawings supplied with this manual (see Appendix F) show an example of the CLM connections to a typical metalforming machine.

6.8 CLM Connectors

This section describes all the connectors on the CLM module. Refer to Figure 1.5 in Chapter 1 for an illustration of the CLM module and its connector locations.

X - 1: Encoder Input Axis 1

Female, DB 25 connector is located on the top of the CLM and used for inputs from the respective encoder assembly for axis 1 and measuring encoder.

X - 2: Encoder Input Axis 2

Female, DB 25 connector is located on the top of the CLM and used for inputs from the respective encoder assembly for axis 2.

X - 3: System Input

Male, DB 37 connector is located on the top of the CLM and used for inputs from various locations of the system (see Chapter 3 for I/O descriptions; see Table 2.1 for quick reference to I/O connections).

X - 4: System Output

Female, DB 37 connector is located on the top of the CLM and used for various outputs (see Chapter 3 for I/O descriptions; see Table 2.1 for quick reference to I/O connections).

X - 5: Command Connector

A 15 pin Phoenix connector is located on the lower front panel of the CLM. This is a multi-functional connector.

The various contacts of X - 5 are:

- 24 Vdc Power Supply - pins 1 & 2
- Bb motor Contacts - pins 3 & 4
- Analog Command Axis 1 (A1) - pins 5 & 6
- Analog Command Axis 2 (A2) - pins 8 & 9
- Ground (not used) - pins 7 & 10
- Analog Input, Axis 1 (AE1) - pins 11 & 12
- Analog Input, Axis 2 (AE2) - pins 14 & 15

NOTE: To prevent a ground loop condition, connect the shields for the command cables to the servo amplifier only. Refer to Appendix F, drawing BE 1117, sheet 3, coordinates B1.

X - 6: RS-232/422/485 Communications Port (Interface)

Female, DB 25 connector is located on the lower front panel of the CLM. It is used for serial communication between the CLM and a host terminal, SOT or the IDS option. Refer to Chapter 7 for description of this multi-functional, two-way communications port.

X - 7: Auxiliary Drive Connector

An 8 pin Phoenix connector is located above the X - 5 connector on the lower front panel of the CLM. See Figure 2.3 for an illustration and description of the lower front connector panel.

The various contacts of X - 7 are:

- Enables Axis 1 Amplifier for operation (RF1) - pin 1
- Enables Axis 2 Amplifier for operation (RF2) - pin 2
- Potentiometer supply for analog override (+10 Vdc) - pin 3
- Analog Input, Axis 3 (AE3/0 Vdc) - pins 4 & 5
- Ground (not used) - pin 6
- Analog Input, Axis 4 (AE4 +/-) - pins 7 & 8

X - 11 & 12: Optional System Input

These connectors are included with the optional Expanded version CLM only. These Male, DB 37 connectors are located on the top of the CLM and used for inputs from various locations of the system (see Chapter 3 for I/O descriptions; see Table 2.1 for quick reference to I/O connections).

X - 13: Optional System Output

This connector is included with the optional Expanded version CLM only. This Female, DB 37 connector is located on the top of the CLM and used for various outputs (see Chapter 3 for I/O descriptions; see Table 2.1 for quick reference to I/O connections).

X - 19: Command and Drive Enable Connector

A 7 pin Phoenix connector is located on the bottom of the CLM. This is a multi-functional connector.

The various contacts of X - 19 are:

- Analog Command Axis 3 (A3) - pins 1 & 2
- Ground/shield (not used) - pin 6
- Analog Command Axis 4 (A4) - pins 4 & 5
- Enable Axis 3 Amplifier for operation (RF3) - pin 6
- Enable Axis 4 Amplifier for operation (RF4) - pin 7

NOTE: To prevent a ground loop condition, connect the shields for the command cables to the servo amplifier only. Refer to Appendix F, drawing BE 1117, sheet 3, coordinates B1.

X - 20: Encoder Input Axis 3

Female, DB 25 connector is located on the bottom of the CLM and used for inputs from the respective encoder assembly for axis 3.

X - 21: Encoder Input Axis 4

Female, DB 25 connector is located on the bottom of the CLM and used for inputs from the respective encoder assembly for axis 4.

X - 22: System Input/Output

Male, DB 25 connector is located on the bottom of the CLM and used for various system (axis 3 and 4) and auxiliary inputs and outputs (see Chapter 3 for I/O descriptions; see Table 2.1 for quick reference to I/O connections).

6.9 Pre-Operation Start Up Tests

The following sections are intended to provide the user with an example of a CLM start-up. They provide an example of a single axis application that will verify proper function of the system.

WARNING: The information given in the following sections may not be suitable for a specific application. If you use this example for testing, do not mechanically connect the servomotor to the actual load.

Refer to the drawings in the Appendixes F and G for additional mounting and connection information.

6.10 Connections

NOTE: Do NOT apply power until all connections have been made. Refer to section 6.8 for connector descriptions.

1. Install the TVM (or KDV) power supply and the TDM (or KDS) amplifier per their respective support manuals.
2. Make connections to the CLM Command Connector X5 (24 Vdc supply, Bb motor contacts, analog command for each servo amplifier).
3. Make the motor connections per drawings in Appendix F, and the TDM and motor support manuals.
4. Connect the encoder(s) to X1 connector for axis 1; X2 connector for axis 2; X20 connector for axis 3; X21 connector for axis 4.

6.11 Inputs

The connections in this example for a single axis application are minimized for the sake of simplicity. If desired, add connections for axis 2, as illustrated in Figure 6.2. Refer to the interconnect drawings in Appendix F for any additional details. Connect the incoming side of each switch to a +24 Vdc source.

1. Connect a 2-position selector switch to provide a +24 Vdc signal to Pin 2 (Automatic Mode input). The second position is not wired (0 Vdc), and is used for Manual Mode (default mode). Connect a key switch to provide +24 Vdc to Pin 1 (Parameter Mode input).
2. Connect a Normally Closed pushbutton switch to Pin 3 (Emergency Stop) of the System Input Connector X3.
3. Connect a Normally Open momentary switch to Pin 4 (Cycle Start) of connector X3.
4. Connect a Normally Closed momentary switch to Pin 5 (Cycle Stop) of connector X3.
5. Connect the Bb Contact of the drive amplifier to Pin 6 (Axis #1 Amplifier Ready) of connector X3.
6. Connect a Normally Open momentary switch to Pin 9 (Jog Forward) of connector X3..
7. Connect a Normally Open momentary switch to Pin 10 (Jog Reverse) of connector X3.
8. Connect an external power supply to pins 34 and 35 (0 Vdc) and pins 36 and 37 (+24 Vdc) of connector X3.

6.12 Outputs

The output for Amplifier Enable (Systems Output Connector X4 - Pin 4, or RF Connector X7 - Pin 1) must be connected to the Drive. Connector X4, pins 34 and 35 must be connected to 0 Vdc of the external supply. Connector X4, pins 36 and 37 must be connected to +24 Vdc of the external supply. See the interconnect drawings in Appendix F.

6.13 Power-up

The system can now be powered up. All voltages should be checked by a qualified electrician to ensure proper signals and connections.

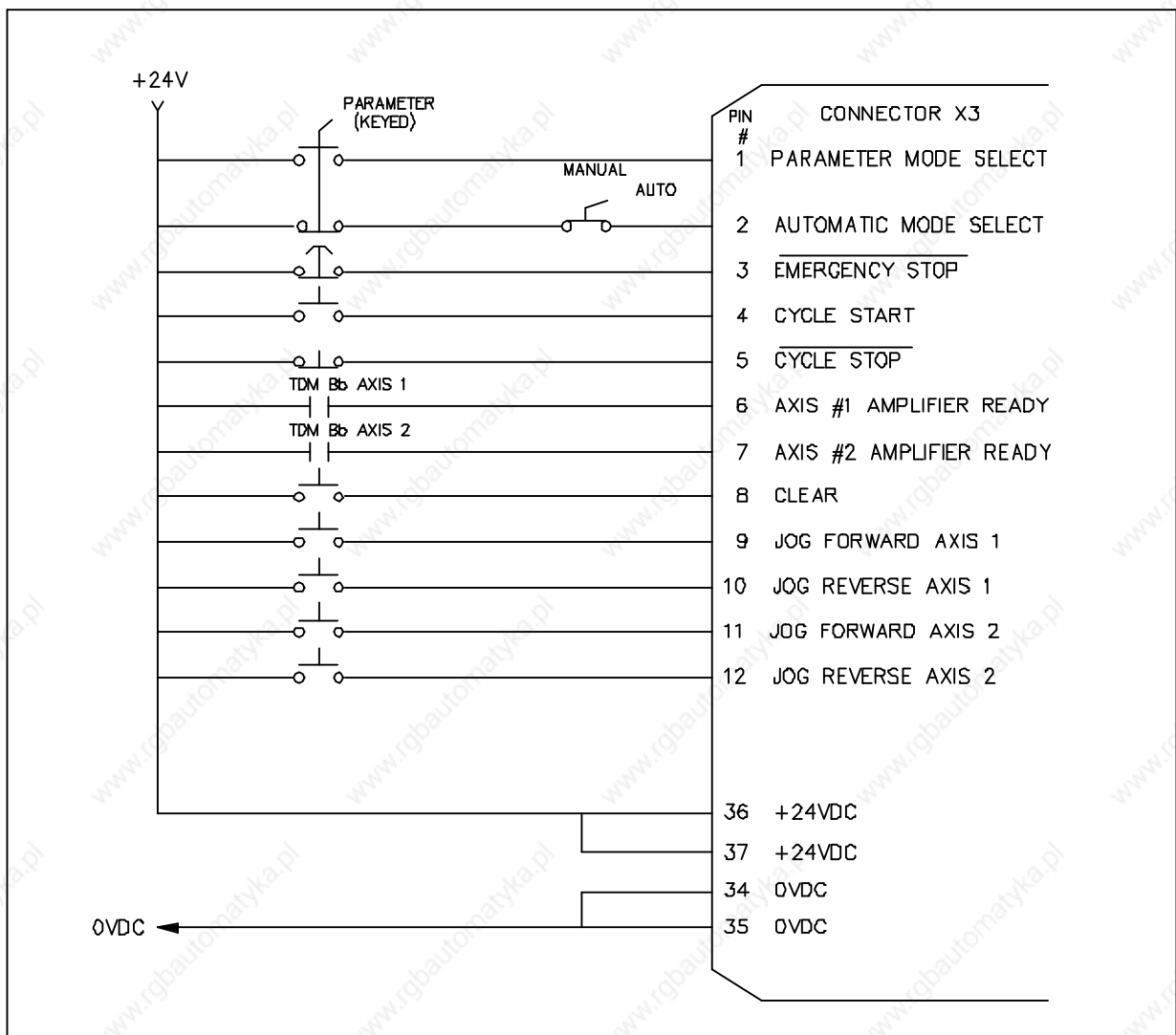

Figure 6-2 Example Input Diagram

6.14 Parameter Entry

The parameters given here are the minimum required to operate the CLM for this example. The following descriptions assume an IU = 1 inch. Turn the key switch to the Parameter Mode to enable parameter entry. Enter the following parameters (refer to Chapter 4 for parameter entry procedures or for further description of each parameter, if necessary); also enter A2xx parameters when testing a 2-axes system.

- B007 Language 01030000 (English display, resolution to 3 places)
- A100 Max Velocity Refer to Amplifier personality module nameplate for E1/E2 rating. See example entries at bottom of page.
- A101 Jog Velocity 00005000 (5.0 in/sec)
- A102 Acceleration 00000250 (25.0 in/sec²)
- A103 Position Gain 00000100 (1.0 in/min/mil of Following Error)
- A104 Encoder Lines/Rev. Refer to motor encoder nameplate.

The two most common encoders are:

- 625 Enter 00000625 (625 lines/encoder rev)
- 1250 Enter 00001250 (1250 lines/encoder rev)
- A106 Position Tolerance 15000050 (output 15, Axis 1 pos. tol.= 0.050 in)
- A108 Feed Constant 01000000 (1.0 in/motor rev)
- A109 Direction 00000000 (direction of operation is unchanged)
- A121 Drive Input Sensitivity Refer to Amplifier personality module nameplate for E1/E2 rating. See example entries below.
- A122 Monitor Window 00000010 (10% window)

Following are three examples for A100 and A121 input. Refer to Parameter Ax00 description to calculate the Max Velocity.

- | • E1/E2 Sensitivity | A121 Entry | A100 Entry | |
|---------------------|------------|------------|-----------------|
| • 1500 / 10 V | 15000100 | 00025000 | (25 in/sec) |
| • 2000 / 10 V | 20000100 | 00033333 | (33.333 in/sec) |
| • 3000 / 10 V | 30000100 | 00050000 | (50 in/sec) |

6.15 Program Entry

This is a sample program for operating the CLM in an automatic mode. Enter the program as shown. The WAI command should be stored into block 0001 for the example program shown.

Block 0000

```
E 0000 PSI
1 +00100.000 200
```

Block 0001

```
E 0001 WAI
01.00
```

Block 0002

```
E 0002 PSI
1 -00100.000 200
```

Block 0003

```
E 0003 WAI
01.00
```

Block 0004

```
E 0004 JST
0000
```

- Block 0000 - commands the axis to rotate in the plus direction 100 input units, at 20% of the maximum velocity. Since the feed constant equals 1, the motor should turn 100 revolutions.
- Block 0001 - causes a 1 second delay once the axis has reached position.
- Block 0002 - causes the axis to rotate in the minus direction 100 input units, at 20% of the maximum velocity.
- Block 0003 - causes a 1 second delay once the axis has reached position.
- Block 0004 - jump back to block 0000 and stop. See following sections for testing procedures.

6.16 Axis Jogging In Manual Mode

To verify proper motor hook-up, and control of the motor, jog the axis in Manual Mode. Turn the selector switches to the OFF position so that Automatic nor Parameter Mode inputs are high (defaults to Manual Mode).

NOTE: Verify Drive is ON and H-1 LED on lower front of CLM is ON.

1. Press the Forward Jog pushbutton (connected to X3, Pin 9). The axis should jog in the forward direction, until the button is released.
2. Press the Reverse Jog pushbutton (connected to X3, Pin 10). The axis should jog in the reverse direction, until the button is released.
3. Should either the forward or reverse motor movement fail to react, check all cable connections and verify the CLM is in Manual Mode.

NOTE: If the CLM displays any errors, refer to Chapter 8, Diagnostics.

6.17 Automatic Mode Operation

To run the sample program and check Automatic Mode operation:

1. Turn the selector switch to Automatic Mode (wired to connector X3, Pin 2).
2. Press the Cycle Start pushbutton (connected to X3, Pin 4)

NOTE: The CLM will execute the sample program and stop after one cycle. Change block 0004 to JMP 0000 to run the cycle continuously.

3. Press the Cycle Stop pushbutton to stop operation. Press Cycle Start to restart the program.

NOTE: Cycle Stop will cause an immediate stop without error. Emergency Stop will cause an immediate stop also, but will cause a fault to be displayed. De-actuate the E-stop switch and press the CL (clear) key on the CLM keypad to clear the fault, to allow restarting the operation.

7. SERIAL INTERFACE

The CLM Control includes a multi-format RS-232/422/485 port for two-way communication of programs, parameters and system status between the CLM and a host device. The interface protocol is designed to easily transmit and receive data to and from the CLM. This chapter describes the protocol and other communication requirements.

The host device must strictly adhere to the communications format as described in this chapter to achieve proper communication, or one of several "RS Format Errors" will be returned through the port (or indicated on the control status display, see Figure 2.2 for a map of displays) indicating that the information was not properly formatted or understood.

User programs (Block information) can be downloaded to the CLM when it is in any mode of operation (Auto, Manual, or Parameter). The same is true for system status. System parameters can be downloaded to the CLM, only when it is in Parameter Mode. If attempted in any other mode, the host receives a "Invalid Mode" error message through the port. Parameters can be read from the CLM in any mode.

The optional Indramat program assembler software (MotionManager™) allows you to write and edit user programs and parameter list on any DOS based computer. You can download these into the CLM control through the serial interface. You can also upload the information from the CLM and make a print out of your program and parameter files.

The optional Indramat SOT (Station Operator Terminal) is a remote mounted, operator control device for the CLM. It is used to communicate program and parameter information between the CLM and SOT. The software in the SOT includes Help screens to assist the operator in using the SOT and for entering information correctly. The Indramat command line editor (Screen Manager), is used to write information and prompt lines for the operator that will appear on the SOT display (16 lines, 40 characters each). Contact Indramat for additional information on these options.

7.1 Connector Wiring (DB-25)

The serial interface connector (standard DB 25), is located on the lower front of the CLM Control Module (see Figure 2.3 in Chapter 2 for an illustration of the lower front connector area of the CLM).

Refer to Figure 7.1 for a pin-out diagram of the multi-function port (X6 connector). It shows the pin numbers and definitions of signal connections for each type of communication.

CAUTION: Do not connect to any pin numbers, other than those shown in Figure 7.1. Some pins are used for Indramat options and factory diagnostics.

RS-232 CONFIGURATION

- 1 - SHIELD
- 2 - TRANSMIT
- 3 - RECEIVE
- 7 - GROUND

RS-422 CONFIGURATION

- 1 - SHIELD
- 7 - GROUND
- 13- RECEIVE
- 14- RECEIVE
- 15- TRANSMIT
- 16- TRANSMIT

RS-485 CONFIGURATION

- 1 - SHIELD
- 7 - GROUND
- 11- Rx/Tx +
- 12- Rx/Tx -

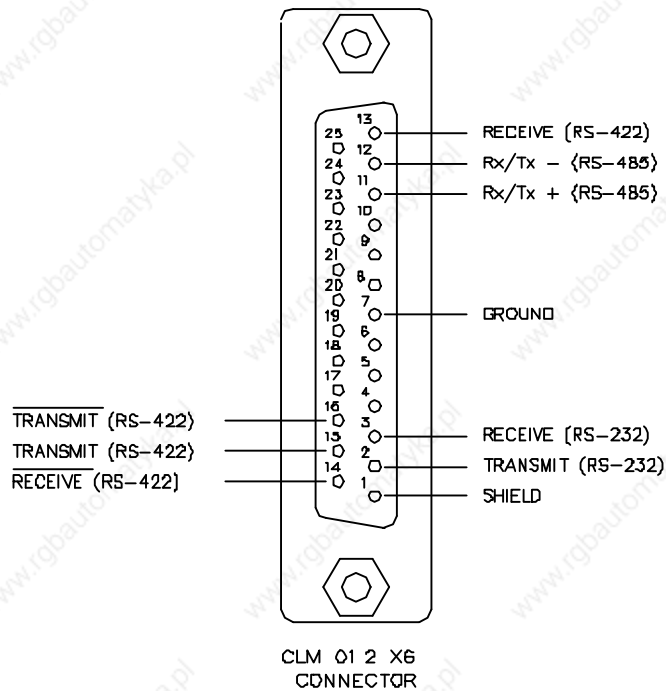

Figure 7-1 CLM X6 Connector

7.1.1 Signal Level Requirements

Figure 7.2 illustrates the signal level requirements for the different communications (RS232/422/485) for the CLM. To minimize signal degradation over long cable runs, the serial device driver should provide the following levels:

- RS-232 ± 15 Vdc (50 ft maximum run)
- RS-422 ± 5 Vdc (1000 ft maximum run)
- RS-485 ± 5 Vdc (3000 ft maximum run)

The length of the transition for each word "T" is set in the serial interface parameter B003. The current hardware version is capable of 110 to 19200 baud.

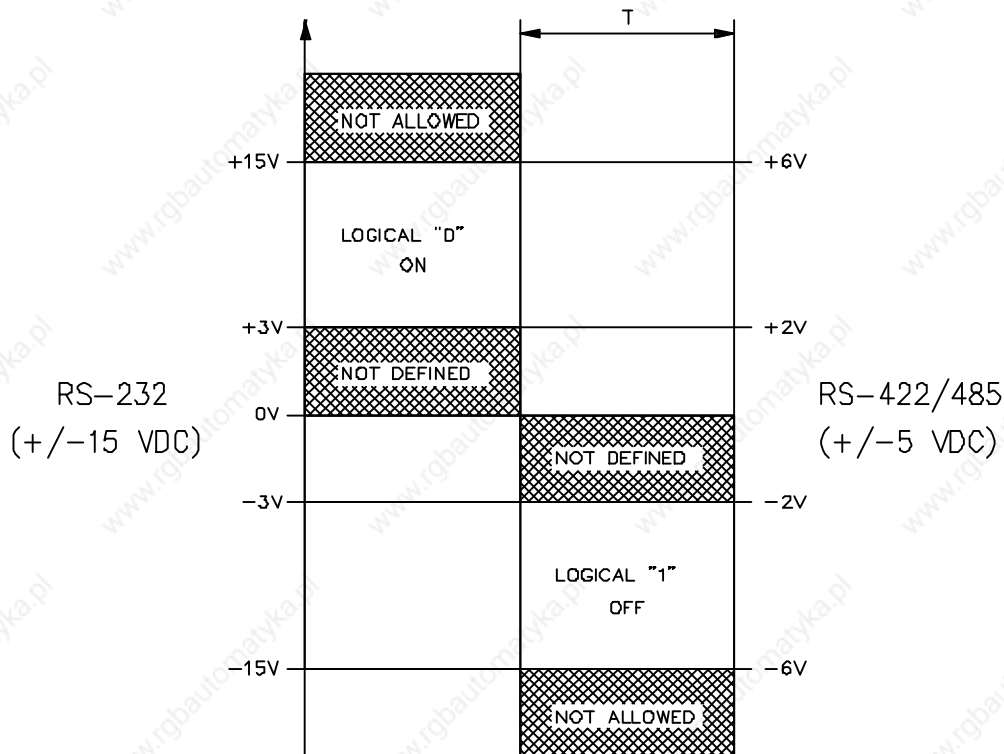

Figure 7-2 Signal Level Requirements

7.1.2 Serial Cable Configurations

For RS-232 serial communications, you should note that the connector on the serial card in your computer can vary in configuration. Figure 7.3 illustrates two common serial connections for interfacing from the RS-232 port of a computer to the CLM.

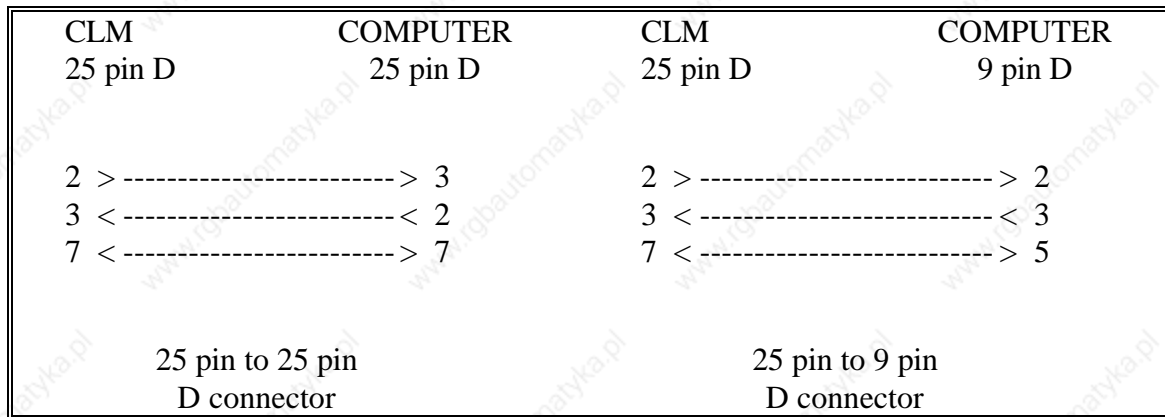

Figure 7-3 RS-232 Serial Cable Configurations

The CLM requires only three lines of the standard 25-pin connector for RS-232 communication. Pin 2 is for Transmitted Data, pin 3 for Received Data, and pin 7 is the Data Signal Ground. Typically, pin 1 connects the cable shield to ground on one end only. The transmit data connection from one device connects to the receive data of the other device, and vice versa. Signal ground connection must be common on both devices. This often requires a Null Modem cable. It connects pin 3 of one end to pin 2 on the other end. Consult the manufacturer's information for the serial card in your computer for its specific pin configuration. You can locally purchase many common cable configurations. You may prefer to buy the required connectors and wire the cable in-house. Note that most serial cards do not provide a signal strong enough to go through a cable longer than about 50 feet. When possible, use a shielded cable no more than 25-50 feet long.

7.2 Data Format

To achieve proper communications, configure the communication parameters (B003 and B004) to match between your computer and the CLM. Figure 7.4 illustrates the data format. Following sections describe each parameter for data communication. Section 7.5 further describes the Checksum options of parameter B004.

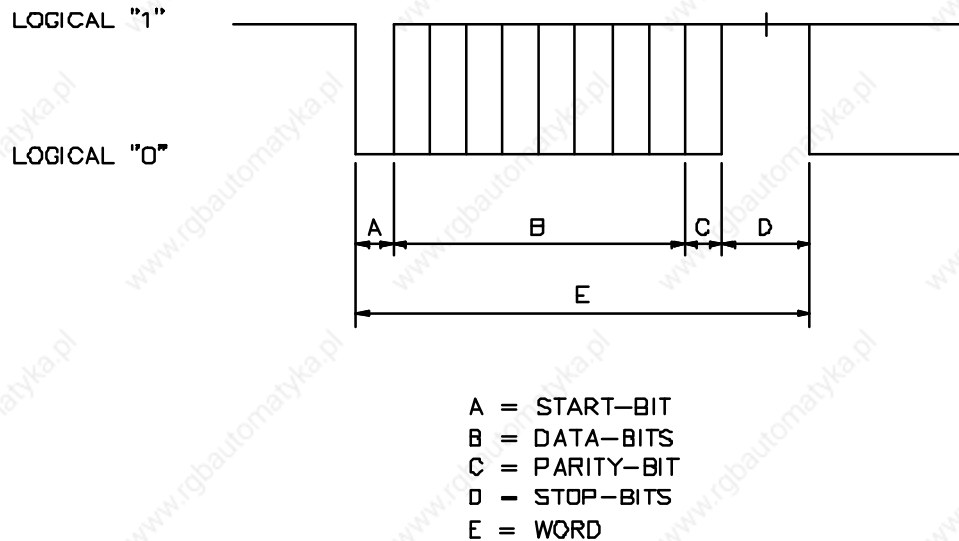

Figure 7-4 Data Format

7.2.1 Word Length

The word length is set in parameter B003 (see Chapter 4 for entry procedures).

- 7 = 7 bit word length
- 8 = 8 bit word length

7.2.2 Parity Check

The parity type is set in parameter B003 (see Chapter 4 for entry procedures).

- 1 = no parity
- 2 = even parity
- 3 = odd parity

7.2.3 Baud Rate

The baud rate is set in parameter B003 (see Chapter 4 for entry procedures). You may choose any baud rate from among the following values:

Parameter Entry	Baud Rate
0015	=0150
0030	=0300
0060	=0600
0090	=0900
0120	=1200
0180	=1800
0240	=2400
0360	=3600
0480	=4800
0570	=5700
0720	=7200
0960	=9600
1920	=19200

7.2.4 Interface Mode

The interface mode is set in parameter B003 (see Chapter 4 for entry procedures). You may choose from among the following:

- 0 = Standard RS232/RS422 (Full Duplex)
- 1 = IDS, decade switch option
- 2 = Same as Mode 0
- 3 = serial port for SOT (Station Operator Terminal); RS-232/422, half duplex, one station ONLY
- 4 = serial bus for SOT; RS-485, half duplex, station 1 through 15

7.3 CLM Control String Protocol

The following sections describe each control character requirements for proper protocol.

7.3.1 First (1) Control String Character (Transmission Type)

All data transmissions to the CLM must start with one of the following control characters to identify what type of transmission is to follow:

- ? Hexadecimal 3F

The CLM interprets this character (received via the RxD channel) as a "Request for Information" - when followed by the proper requesting codes, the CLM will transmit the desired data via the TxD channel.

- # Hexadecimal 23

This character signifies a block of "Information to be Stored" into memory. The data that follows will be read into the proper memory location.

- ! Hexadecimal 21

This character signifies a "System Parameter" or "Control Command" is to follow.

7.3.2 Second (2) Control String Character (CLM Unit # Identifier)

This character is only present if communicating in the RS-485 mode. It is used to identify the CLM unit # to receive the current message. If communicating in RS-232/422 mode, this character will be a space (Hex 20).

Space	=	RS-232/422 Mode	
1	=	CLM#1	RS-485 Mode
2	=	CLM#2	RS-485 Mode
3	=	CLM#3	RS-485 Mode
4	=	CLM#4	RS-485 Mode
5	=	CLM#5	RS-485 Mode
6	=	CLM#6	RS-485 Mode
7	=	CLM#7	RS-485 Mode
8	=	CLM#8	RS-485 Mode
9	=	CLM#9	RS-485 Mode
A	=	CLM#10	RS-485 Mode
B	=	CLM#11	RS-485 Mode
C	=	CLM#12	RS-485 Mode
D	=	CLM#13	RS-485 Mode
E	=	CLM#14	RS-485 Mode
F	=	CLM#15	RS-485 Mode

7.3.3 Third (3) Control String Character (Information Type)

This character is used to identify the type of information to be sent.

- N Hexadecimal 4E

Identifier for a program block. The information which follows this character will be stored as a program block (000-999).

- K Hexadecimal 4B

Identifier for a system parameter. The information which follows this character will be stored as a parameter.

- X Hexadecimal 58

Identifier for CLM status. The status type requested will be sent back to the host device.

7.3.4 Other Important Control Characters

The following are additional control characters required for proper protocol.

- \$ Hexadecimal 24

Identifier for check sum. The two characters following this character represent the check sum of the information transmitted. This check sum must be transmitted along with every transmission.

- CR Hexadecimal OD
- LF Hexadecimal OA

These two characters, CR (Carriage Return) and LF (Line Feed) form the end of every transmission.

- X-ON Hexadecimal 11
- X-OFF Hexadecimal 13

Serial transmission can be controlled using handshaking.

- If the CLM is sending data via the TxD channel and receives the "X-OFF" signal (Hexadecimal 13/ASCII DC3) via the RxD channel, the CLM will interrupt the transmission until the "X-ON" signal (Hexadecimal 11/ASCII DC1) is received again via the RxD channel.
- If the CLM is receiving data via the RxD channel, and an interruption of the data transmission becomes necessary, the CLM will send the "X-OFF" signal (Hexadecimal 13/ASCII DC3) via the TxD channel. When the transmission can be resumed, the CLM will send the "X-ON" signal (Hexadecimal 11/ASCII DC1) via the TxD channel.

7.4 Information Characters

All information characters are coded in hexadecimal. The following characters are used for exchange of information:

0	Hexadecimal 30
through	through
9	Hexadecimal 39
A	Hexadecimal 41
through	through
Z	Hexadecimal 5A

Used as command codes for the CLM, depending on programming,

A - Z must be uppercase.

_ (space) Hexadecimal 20

For creating the desired format, the space-character is used.

NOTE: This chapter indicates a space with the underline character.

+ Hexadecimal 2B

- Hexadecimal 2D

The operational sign must be transmitted for feed blocks

. Hexadecimal 2E

, Hexadecimal 2C

Used in data fields, depends on Language selected if responds with period (.) or comma (,). The CLM treats both the same.

7.5 CHECKSUM Calculations

If checksum is enabled in parameter B004, the following example shows how it would be calculated. After all characters are added together, the High-byte is added to the Low-byte, then the compliment of the two is taken. This number should immediately follow the "\$" character.

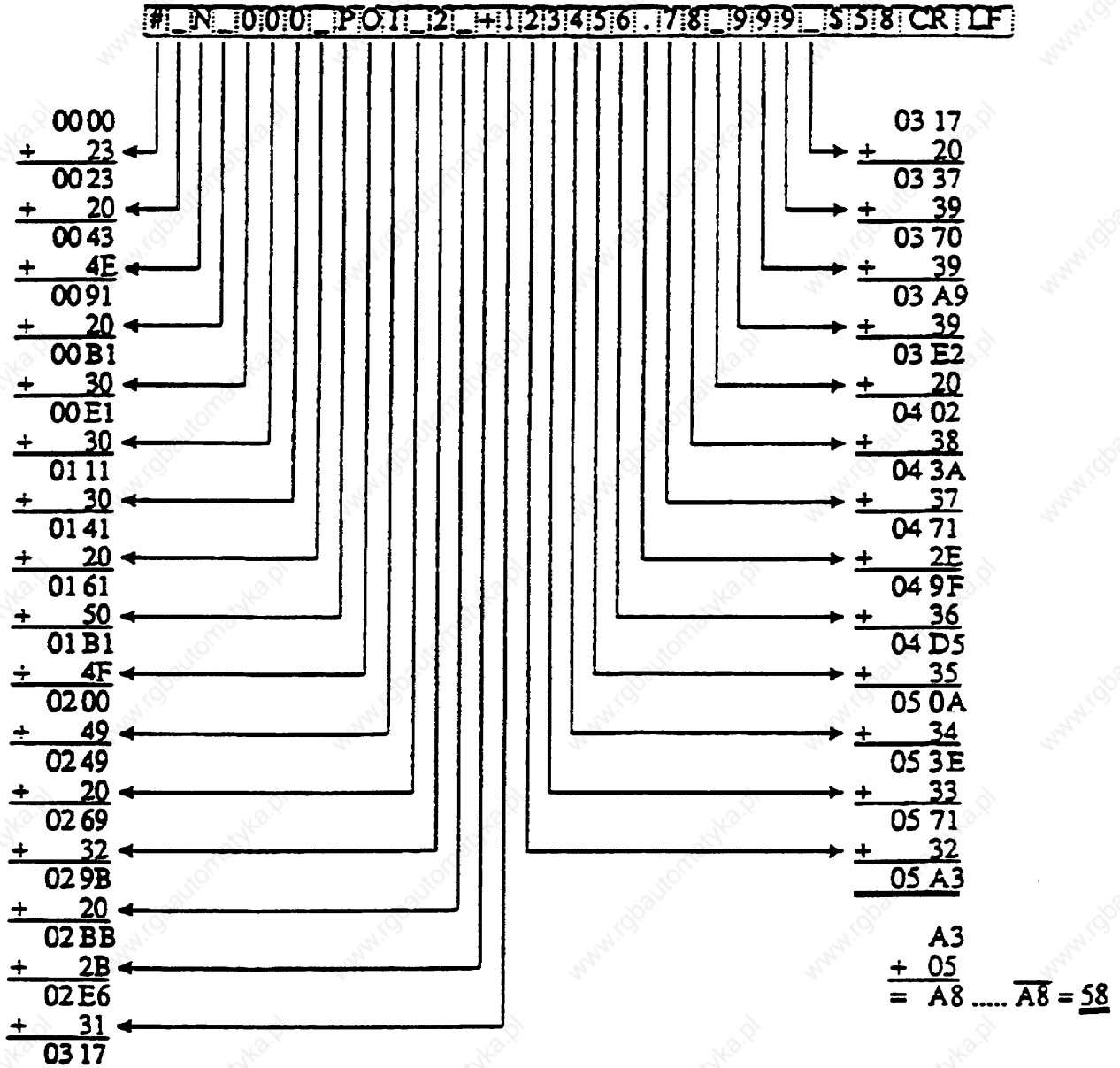

Figure 7-5 CHECKSUM Example Calculation

7.6 Sending Information to the CLM

The CLM is capable of receiving new program block and parameter data from a host device, using the set of protocols described in the following sections. They use the key characters defined in sections 7.3 to 7.5, and a set data field to transfer the required information.

To get a acceptable transmission, it is very important that all characters, including all spaces, are used in the exact described format when sending to the CLM. If there is any type of discrepancy, the CLM will respond with an error message describing the type of format error that was found, and the current data will not be changed.

7.6.1 Sending Program Blocks to the CLM

A program block sent to the CLM must follow this format:

#_N_bbbb_ccc_dddddddddddddddd_\$hhCRLF

The following describes each part of the command string:

#_N	Send program block to CLM
bbbb	Block Number
ccc	Command Mnemonic
dd-->dd	Data, 16 characters in the proper format for a given command
\$	End of block (check sum may follow)
hh	Check sum (if enabled in parameter 42)
CrLf	Carriage Return, Line Feed

NOTE: All transmitted data fields must be comprised of 16 characters. Send trailing spaces to fill the data block.

The following provides example of command strings for program blocks with different size data fields. Note the information as it appears on the CLM display, then the format required to send the information, filling all 16 characters positions of the data field.

Display Screens

E	0100	AEA
07	0	

E	0101	PSI
1	+02345.678	

Serial Data To Transmit

(same information that can be entered from the CLM keypad on the Edit display screens above)

```

#_N_0100_AEA_|07_0_____|_$5BCRLF
      |         |
      | Data Field |
      |*****|
#_N_0101_PSI_|1_+12345.678_999|_$53CRLF
      |         |
    
```

Refer to Chapter 5 for description of each command and its data field requirements. Table 7.1 illustrates the serial data string arrangement for each command and its data field.

7.6.2 Sending Parameters to the CLM

Parameters sent to the CLM must follow this format:

```
!_K_y y x x _ d d d d d d d _ $ h h CR LF
```

The following describes each part of the command string:

- !_K Send parameter to CLM
- yy Parameter Set (see table below for entry)
- xx Parameter Number (see table below for entry)
- dd-->dd Data, 8 characters in the proper format for a given parameter
- \$ End of block (check sum may follow)
- hh Check sum (if enabled in parameter B004)
- CrLf Carriage Return, Line Feed

Parameter set	Code (yy=)	Parameter number (xx=)
General parameter	B0	00 to 14
Axis 1 parameter	A1	00 to 22
Axis 2 parameter	A2	00 to 22
Axis 3 parameter	A3	00 to 22
Axis 4 parameter	A4	00 to 22

NOTE: The CLM must be in Parameter Mode before sending parameter information, or an error will be issued.

Table 7-1 CLM-01.3-A / LA01.3-01.x Program Command Format

ACC_1__999_____	Acceleration Change
AEA_07__1_____	Auxiliary Output ON/OFF
AKN_07__1_____	Acknowledge Single Input
AKP_0____0001112220	Parallel Acknowledgment Input
APE_0____0001112220	Parallel Outputs ON/OFF
APJ_12344_0001112220	Set Parallel Outputs, then Jump
ATS_07__1_____	Output State Monitor
BAC_1234_+1234_12345	Branch And Count
BCA_1234_07__1_____	Output-Dependent Conditional Branch
BCB_123420__1_____	Binary Input Conditional Branch
BCD_123420_____	BCD-Dependent Conditional Branch
BCE_1234_07__1_____	Input-Dependent Conditional Branch
BIO_12341_0001112220	Branch Input/Output Compare
BMB_1234_10_04_8_____	Binary Output-Dependent Conditional Branch
BPA_12341_0001112220	Branch on Parallel Outputs
BPE_12341_0001112220	Branch on Parallel Inputs
BPT_12342_+12345.678	Branch If Position Has Been Reached
BZP_12342_+12345.678	Branch if Target Position Exceeds Position Limit
CID_12341_0_+1234567	Change Instruction Data
CIO_0_01_23_4_____	Copy Input/Output to Output
CLA_1_____	Clear Axis (Absolute Encoder Value)
CLC_1456_____	Clear Counter
COC_1_07_001122_+360	Cam Output Control
CON_1__0_+999_07_____	Continuous Operation (ON/OFF)
COU_+12345_12_123456	Count
CST_1_1_____	Change Subroutine Stack - Pointer
FAK_1__1.234567_____	Factor All Motions (All Positions by X)
FMS_1_123.4_01_01_01	Follow Master
FOL_1__2__1.234567__	Axis Synchronization (on/off)
FUN_2_2_1_2222_____	Functions
HOM_1_____	Home Axis
JMP_1234_____	Unconditional Jump (to block)
JSR_1234_____	Jump to Subroutine
JST_1234_____	Jump and Stop
JTK_1234_1_____	Jump in Task (task interrupt)

KDI_2000_1000_1_	Copy Position Difference
NOP_	Blank Block (no operation)
PBK_1_	Position Break
POA_1_+12345.678_999	Position Absolute Feed
POI_1_+12345.678_999	Position Incremental Feed
POM_1_0_1_	Incremental Feed to Decade Switch Position
PSA_1_+12345.678_999	Absolute Feed with Position Acknowledgment
PSI_1_+12345.678_999	Incremental Feed with Position Acknowledge
PSM_1_0_1_	Feed to Decade Switch Pos. w/ Acknowledge
PST_1_01_+12345.678	Position Test
REF_1_0_999_12_	Detect Registration Mark Input
REP_1234_1_12345.678	Registration Search Limit Branch
RMI_0_01_	Registration Mark Interrupt
RSV_1_000_100000_	Restart Vector
RTS_	Return from Subroutine
SAC_1_0_+12345.678	Set Absolute Counter
SIN_1_07_12.345_123	Sine Oscillation
SO1_1_1_07_1234_	Scanning of Inputs and Modifying a Length
SO2_1_+123.456_2_	Position Correction via the Analog Input
STH_0_0000_	Send to Host
VCA_1_+12345.678_999	Velocity Change Absolute
VCC_1_12345.678_999	Velocity Change
VEO_1_1_1_999_0_	Velocity Override Command
WAI_01.00_	Time Delay (Wait)
WRI_1234_011_	Write in Absolute Position (teach command)

7.7.2 Requesting a System Parameter from the CLM

It is not necessary to be in Parameter Mode to request parameter data.

The computer Sends a Request in the format as follows:

?_K_y y x x _ CR LF

The following describes each part of the command string:

?_K - Send parameter to host

yy - Parameter Set

xx - Parameter Number

CrLf - Carriage Return, Line Feed

The CLM responds to the requested parameter in the following format:

!_K_y y x x _ d d d d d d d _ \$ h h CR LF

The following describes each part of the command string:

!_K Sending parameter to host

yy Parameter Set

xx Parameter Number

dd-->dd Parameter Data

\$ End of block (check sum may follow)

hh Check sum (if enabled in parameter B004)

CrLf Carriage Return, Line Feed

Parameter set	Code (yy=)	Parameter number (xx=)
General parameter	B0	00 to 14
Axis 1 parameter	A1	00 to 22
Axis 2 parameter	A2	00 to 22
Axis 3 parameter	A3	00 to 22
Axis 4 parameter	A4	00 to 22

Examples:

Query: ?_K_B003 (Serial interface)

Reply: !_K_B003_19200181

Query: ?_K_A308 (feed constant axis 3)

Reply: !_K_A308

7.7.3 Requesting System Status from the CLM

The following System Status Information can be requested from the CLM.

- 00 Current Position of each Enabled Axis (in decimal)
- 01 Transmission Error # and text
- 02 Current program block (task 1 only)
- 03 Position of each Enabled Axis (Hex)
- 04 Counter status
- 05 Software version
- 06 Input status
- 07 Output status
- 08 Current block and RTS return block (all tasks)
- 09 Measuring wheel encoder
- 10 Position Lag, Axis 1 & 2
- 19 Hardware and Software Version
- 42 Actual Motor RPM, Axis 3 & 4
- 43 Position Lag, Axis 3 & 4
- 44 Current Position, Axis 3 & 4
- 45 Analog Input, Axis 3 & 4
- 46 Length Counter
- 47 Actual RPM, Measuring Wheel
- 48 Actual Motor RPM, Axis 1 & 2
- 49 Analog Input, Axis 1 & 2
- 50 System inputs and outputs (Hex)
- 51 User inputs (1-88) (Hex)
- 52 User outputs (1-96) (Hex)
- 53 System Faults

Each Status Request and CLM Response is described on the following pages.

7.7.3.1 Status 00 Current Position of each Enabled Axis (in decimal)

Request format:

? _ X _ _ 0 0 _ Cr Lf

Response format:

X _ 0 0 _ e d 1 1 1 1 1 . 1 1 1 1 _ e d 2 2 2 2 2 . 2 2 2 _ \$ h h Cr Lf

e "_" if axis has not been Homed, "A" if axis has been Homed

d Direction (+/-)

11111.111 Current position of Axis 1 (in decimal format, in input units)

22222.222 Current position of Axis 2 (in decimal format, in input units)

7.7.3.2 Status 01 RS Transmission Error # and text

This information is sent automatically by the CLM when there is a RS communication format error received via the port. This information cannot be requested.

Transmission format:

X _ 0 1 _ e e _ t t t t t t t t t t t t t t t t _ _ _ _ _ \$ h h Cr Lf

e Error Number

t Error Text

7.7.3.3 Status 02 Current program block (for task 1 only)

Request format:

? _ X _ _ 0 2 _ Cr Lf

Response format:

X _ 0 2 _ N N N N _ n n n n _ \$ h h Cr Lf

N Current Block Number

n Return to Main program Block number, if in a sub-routine (JSR Stack pointer)

7.7.3.4 Status 03 Current Position of each Enabled Axis (Hexadecimal format)

Request format:

? _ X _ _ 0 3 _ Cr Lf

Response format:

X _ 0 3 _ z z z z z z z z _ y y y y y y y y _ _ _ _ _ \$ h h Cr Lf

zzzzzzzz Current position of Axis 1 (in Hexadecimal format)

yyyyyyyy Current position of Axis 2 (in Hexadecimal format)

Response is in Hexadecimal. Use the following formulas to convert to Input Units, or use status requests 00 and 44 for current axis position of axes 1 and 2, and axes 3 and 4 in decimal format.

For Linear: IU's = $\frac{zzzzzzzz * Ax08}{Ax04 * 4}$

For Rotary: IU's = $\frac{zzzzzzzz * Ax08}{360^\circ (Ax05)}$

7.7.3.5 Status 04 Counter status

Request format:

? _ X _ _ 0 4 _ N N N N _ Cr Lf

Response format:

X _ 0 4 _ N N N N _ a a a a a a _ t t t t t t _ _ _ _ _ \$ h h Cr Lf

N Counter block number

aaaaaa Actual count

tttttt Target count

7.7.3.6 Status 05 Software version

Request format:

? _ X _ _ 0 5 _ Cr Lf

Response format:

X _ 0 5 _ _ v v v v v v v v v v v v v v v v v v _ \$ h h Cr Lf

v = Software version (as displayed on the CLM Front panel)

Example: " __LA01.3-01.0__ "

7.7.3.7 Status 06 Input Status

Request format:

? _ X _ _ 0 6 _ b _ Cr Lf

Response format:

X _ 0 6 _ b _ e e e e e e e e e e e e e e e e e e _ \$ h h Cr Lf

- b Bank number (Input range)
 - 0 System Inputs 1-16
 - 1 Aux. Inputs 1-16
 - 2 Aux. Inputs 17-32
 - 3 Aux. Inputs 33-48
 - 4 Aux. Inputs 49-64
 - 5 Aux. Inputs 65-80
- e State of each of 16 inputs in sequence, as follows:
 - 0 OFF (0 Vdc)
 - 1 ON (24 Vdc)

7.7.3.8 Status 07 Output Status

Request format:

? _ X _ _ 0 7 _ b _ Cr Lf

Response format:

X _ 0 7 _ b _ a a a a a a a a a a a a a a a a _ \$ h h Cr Lf

- b Bank number (Output range)
 - 0 System Outputs 1-16
 - 1 Aux. Outputs 1-16
 - 2 Aux. Outputs 17-32
 - 3 Aux. Outputs 33-48
 - 4 Aux. Outputs 49-64
 - 5 Aux. Outputs 65-80
 - 6 Aux. Outputs 81-96
 - 7 Aux. Outputs 97-99
- a State of each of 16 outputs in sequence, as follows:
 - 0 OFF (0 Vdc)
 - 1 ON (24 Vdc)

7.7.3.9 Status 08 Current block (for all tasks)

Request format:

? _ X _ _ 0 8 _ Cr Lf

Response format:

X _ 0 8 _ 0 1 0 0 _ 0 2 0 0 _ 0 3 0 0 _ 0 4 0 0 _ 0 5 0 0 _ 0 6 0 0 _ \$ h h Cr Lf

- 0100 Task 1 - Current block number
- 0200 Task 1 - Main program block number
- 0300 Task 2 - Current block number
- 0400 Task 2 - Main program block number
- 0500 Task 3 - Current block number
- 0600 Task 3 - Main program block number

The CLM returns the current block number of each task.

It also will return the main program block number if a given task is in a sub-routine (first level of the JSR stack pointer).

If not in a sub-routine, the current block number is repeated for the main program return block.

If a task has not been activated, spaces will be returned in the appropriate locations.

7.7.3.10 Status 09 Measuring Wheel / Motor Encoder (Position Readings)

Request format:

? _ X _ _ 0 9 _ Cr Lf

Response format:

X _ 0 9 _ _ x ± 1 2 3 4 5 . 6 7 8 _ ± 1 2 3 4 5 . 6 7 8 _ \$ h h Cr Lf

- X_09 Status 09
- _ Reserved - not used at present
- x "A" - Axis 1 has been Homed
- "_" - Axis 1 has not been Homed
- ±12345.678 First Position Axis 1 in EGE
if Measuring Wheel activated, all MW movements are used
if MW deactivated, all motor transmitter movements are used
- ±12345.678 Second Position Axis 1 in EGE

7.7.3.13 Status 42 Actual Motor RPM, Axis 3 & 4

Request format:

_ X _ _ 4 2 _ Cr Lf

Response format:

_ 4 2 _ 3 _ d 1 2 3 4 . 5 6 _ 4 _ d 1 2 3 4 . 5 6 _ \$ h h Cr Lf

X_42	Status 42
3	0 = axis 3 is turned off, 1 = axis 3 is turned on
d	Direction (+/-)
31234.56	Actual Motor RPM for Axis 3
4	0 = axis 4 is turned off, 1 = axis 4 is turned on
d	Direction (+/-)
31234.56	Actual Motor RPM for Axis 4

7.7.3.14 Status 43 Position Lag, Axis 3 & 4

Request format:

_ X _ _ 4 3 _ Cr Lf

Response format:

_ 4 3 _ d 3 3 3 3 3 . 3 3 3 _ d 4 4 4 4 4 . 4 4 4 _ \$ h h Cr Lf

X_43	Status 43
d	Direction (+/-)
33333.333	Position Lag for Axis 3
44444.444	Position Lag for Axis 4

7.7.3.15 Status 44 Current Position, Axis 3 & 4

Request format:

`_ X _ _ 4 4 _ Cr Lf`

Response format:

`X _ 4 4 _ e d 3 3 3 3 3 . 3 3 3 _ e d 4 4 4 4 4 . 4 4 4 _ $ h h Cr Lf`

X_44	Status 44
e	"_" if axis has not been Homed "A" - if axis has been Homed
d	Direction (+/-)
33333.333	Current Position of Axis 3
44444.444	Current Position of Axis 4

7.7.3.16 Status 45 Analog Input, Axis 3 & 4

Request format:

`_ X _ _ 4 5 _ Cr Lf`

Response format:

`_ 4 5 _ P V V V V V V _ _ P V V V V V V _ _ $ h h Cr Lf`

X_45	Status 45
P	Polarity (+/-) of voltage at analog input
V	Voltage at analog input (mV)

Polarity (P) and voltage (V) for analog inputs for axis 3 and 4 returns in this string.

7.7.3.17 Status 46 Length Counter

Request format:

_ X _ _ 4 6 _ A _ Cr Lf

A = Axis number (1 or 2), 0 = Measuring wheel

NOTE: When A = 0: If the measuring wheel option has not been set in parameters B 009 and B 010, the error message 'M-Wheel P.' will be sent instead of Status 46..

Response format:

X _ 4 6 _ A _ d 1 2 3 4 5 . 6 7 8 _ \$ h h Cr Lf

X_46	Status 46
A	Axis number (1-4)
d	Direction (+/-)
12345.678	Length selected axis has fed between the programmed ON and OFF of the command FUN (in input units)

7.7.3.18 Status 47 Actual RPM, Measuring Wheel

Request format:

? _ X _ _ 4 7 _ Cr Lf

Response format:

X _ 4 7 _ O _ d 1 2 3 4 . 5 6 _ \$ h h Cr Lf

X_47	Status 47
d	Direction (+/-)
O	Measuring Wheel axis
1234.56	Actual RPM of the Measuring Wheel

NOTE: If the measuring wheel option has not been set in parameters B 009 and B 010, the error message '10 M-Wheel' will be sent instead of Status 46.

7.7.3.19 Status 48 Actual Motor RPM, Axis 1 & 2

Request format:

? _ X _ _ 4 8 _ Cr Lf

Response format:

X _ 4 8 _ 1 _ d 1 2 3 4 . 5 6 _ 2 _ d 1 2 3 4 . 5 6 _ \$ h h Cr Lf

X_48	Status 48
1	Axis number 1
d	Direction (+/-)
1234.56	Actual RPM of axis 1
2	0 = axis 2 is turned off, 1 = axis 2 is turned on
d	Direction (+/-)
1234.56	Actual RPM of axis 2

7.7.3.20 Status 49 Analog Input, Axis 1 & 2

Request format:

? _ X _ _ 4 9 _ Cr Lf

Response format:

X _ 4 9 _ P V V V V V _ _ P V V V V V _ _ \$ h h Cr Lf

X_49	Status 49
P	Polarity (+/-) of voltage at analog input
V	Voltage at analog input, mV

Polarity (P) and voltage (V) for analog inputs for axis 1 and 2 returns in this string.

7.7.3.21 Status 50 System Inputs and Outputs Hexidecimal

Request format:

? _ x _ _ 5 0 _ Cr Lf

Response format:

X _ 5 0 _ e e e e a a a a \$ h h Cr Lf

e	Four system inputs (hexadecimal)
a	Four system outputs (hexadecimal)

Table 7-2 Hexadecimal Conversion Table

Weight =	23	22	21	20	e/a
	0	0	0	0	0
	0	0	0	1	1
	0	0	1	0	2
	0	0	1	1	3
	0	1	0	0	4
	0	1	0	1	5
	0	1	1	0	6
	0	1	1	1	7
	1	0	0	0	8
	1	0	0	1	9
	1	0	1	0	A
	1	0	1	1	B
	1	1	0	0	C
	1	1	0	1	D
	1	1	1	0	E
	1	1	1	1	F

Status example:

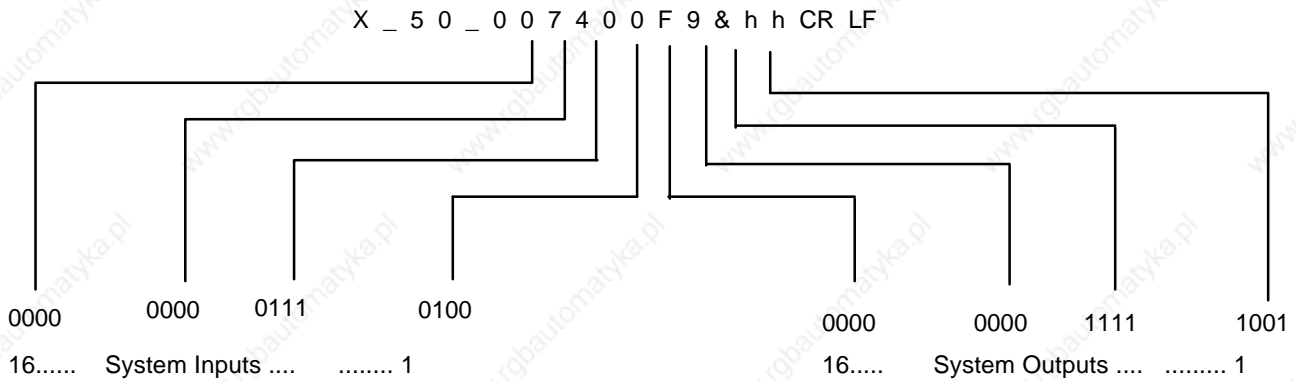

In this example:

- System inputs 3, 5, 6, and 7 are at +24 volts.
- System outputs 1, 4, 5, 6, 7, and 8 are at +24 volts.

8. DIAGNOSTICS AND TROUBLESHOOTING

When the CLM detects an error, all outputs are turned off and the error message appears on the CLM display module. Typically, the word "ERROR" appears on the top line of the display. The second line displays an error message. After the error condition has been corrected, the message must be cleared by pressing the CL key on the CLM keypad, or by providing a +24-volt input to the external Clear input (connector X3, pin 8).

8.1 SYSTEM RELATED ERROR CODES

HEX CODE #	ERROR MESSAGE	DESCRIPTION
00	(No Error Message is Displayed)	When the CLM is operating properly, with no system errors present, requesting the Status Code 53 from a host device causes the CLM to transmit the error code "00." No error message will be displayed.
01	System Failure	Check the wiring in the CLM cabinet. Wiring should be as shown in the installation instructions. This error can also occur during startup or battery replacement, if the parameters have not yet been entered.
02	IS INVALID	This message appears when the value stored in a CLM-LM parameter exceeds the minimum or maximum limits. The message appears on the first line of the display; the second line displays the number of the affected parameter. 1.The parameter containing the invalid input can be displayed by switching into Parameter mode and pressing the CL key on the CLM keypad, or by providing +24 Vdc to the external Clear input (connector X3, pin 8). 2.Consult chapter 4 for the minimum and maximum limits of the parameter in which the error occurred.
03	EMERGENCY STOP	The "EMERGENCY STOP" error occurs when +24 Vdc signal to the CLM Emergency Stop input is interrupted (connector X3, pin 3). 1.The Emergency Stop pushbutton has been pressed. 2.The Emergency Stop circuit has been broken. Consult the machine builder's wiring diagrams to determine what could have caused the break in the E-Stop circuit. 3.+24 Vdc has been applied to CLM connector X5, pins 1 and 2, but CLM connector X3 is not installed. 4.+24 Vdc must be applied to CLM connector X3, pins 36 and 37. Also, the reference (0 Vdc) must be applied to the CLM connector X3, pins 34 and 35.

HEX CODE #	ERROR MESSAGE	DESCRIPTION
04	Battery Is Low	This condition occurs when the lithium battery which retains CLM memory (programs, parameters, counter status, etc.) during power OFF, is below minimum voltage level. A battery test is made at CLM power-up. If the battery is low, the error message is displayed; press Clear to continue. The diagnostic message reappears every ten minutes as a reminder. During normal operation, in any of the three CLM operating modes, a battery test is made every four hours. If the battery is still low, the diagnostic message appears but a fault is not issued. Replace the battery within two weeks of the first appearance of the diagnostic message. Turn power OFF to the CLM, remove the Memory and Battery Module (refer to Figure 2.3), and replace the 3.5-volt lithium battery. Call the Indramat Service Department if you have any questions concerning battery replacement.
05	Parameters Lost	This error will occur when the back-up battery, which stores the CLM parameters when power to the CLM is turned off, is disconnected or the battery voltage is low. 1.If this error occurs every time the CLM is turned off and on, replace the back-up battery. This error might also occur if the firmware is removed or a different CLM firmware is installed. 2.Verify that every CLM-LA parameter has valid numbers stored in each parameter. The CLM-LA parameters might contain asterisks (*), indicating invalid data has been entered. Refer to chapter 4 for information on how to enter the CLM-LA parameters.
06	Program Lost	The error will occur when the back-up battery, which stores the CLM program when power to the CLM is turned off, is disconnected or the battery voltage is low. 1.If this error occurs every time the CLM is turned off and on, replace the back-up battery. This error might also occur if the firmware is removed or a different CLM firmware is installed. 2.Verify that every CLM-LA program has valid numbers stored in each program block. The CLM-LA program commands might contains asterisks (*). Refer to chapter 5 for information on how to enter the CLM-LA program commands. 3.This error will also occur if the number of decimal places in parameter B007 has been changed, but the program blocks were not re-stored correctly. Re-store the program blocks by downloading a program from Motion Manager or by scrolling to the edit screen and pressing the Block Store key.
07	Division By Zero	The error is an internal software fault in the CLM. If this error occurs, contact the Indramat Service Department.

HEX CODE #	ERROR MESSAGE	DESCRIPTION
08	Invalid Mode	An attempt was made to transmit parameter information without first selecting Parameter mode. Also occurs if system inputs #1 and #2, parameter and automatic mode, are on simultaneously. 1. Verify that Parameter mode is selected before transmitting parameter information to the CLM. 2. Check CLM display screen for status of system inputs.
09	Invalid Block #	The program contains a jump or branch command that causes the CLM user program to jump to a block number greater than 2999. NOTE: If Task 3 is being used, enter the Task 3 program in the appropriate program block location, before enabling the Task 3 program in parameter B 006.
0A	Invalid Program Command	The error occurred because the CLM program encountered an invalid program command. NOTE: If Task 3 is being used, enter the Task 3 program in the appropriate program block location, before enabling the Task 3 program in parameter 84. 1.The program command contains asterisks (*). Refer to chapter 5 to determine if the program command is used properly. 2.The auxiliary input or output programmed in the CLM program is zero.
0B	JSR Nesting	This nesting error occurs if the nesting depth of the programmed subroutines is greater than 127. Change the user program so that the number of nested subroutines does not exceed 127.
0C	RTS Nesting	This nesting error occurs when an RTS command is encountered in the CLM program without a matching JSR command. Refer to chapter 5 for information on the JSR and RTS commands. Verify in the CLM user program that a JSR command appears before the RTS command is encountered.
0D	BCD Input	This error will occur if a BCD command is encountered in the user program and the auxiliary inputs are not in a BCD format. Refer to chapter 5 for information on the BCD command. 1.The BCD program commands is programmed incorrectly. 2.Verify auxiliary inputs 1 through 8 are in a BCD format.

HEX CODE #	ERROR MESSAGE	DESCRIPTION
OE	Invalid Block #	The program contains a jump or branch command that causes the CLM user program to jump to a program block greater than 2999. NOTE: If Task 3 is being used, enter the Task 3 program in the appropriate program block location before enabling the Task 3 program in parameter B 006. 1. The BCB, BCD, and BMB program commands can result in a jump or branch to a target block greater than 999. This jump is caused by a combination of an offset, jump distance, or binary input. If either of these commands are used, refer to chapter 5 to determine if the program command is used properly. 2. The branch or jump command contains an asterisk (*) in the target block. Refer to chapter 5 to determine if the program command is used properly.
OF	Fault During WRI Command	WRI command tried to write in a target block which did not contain a POA or PSA command. 1. Check the CLM program blocks.
10	System Fault "Stack Overflow"	The error is an internal software fault in the CLM. If this error occurs, contact the Indramat Service Department.
11	System Fault, "IRQS Interrupt"	The error is an internal software fault in the CLM. If this error occurs, contact Indramat Service Department.
12	IDS Interface Disconnected	Check the cable that connects the IDS to the CLM.

8.2 AXIS RELATED ERROR CODES

HEX CODE #	ERROR MESSAGE	DESCRIPTION
40/70/A0/D0	Drive 1-4 Not Ready	CLM is in Automatic mode, but no signals are present at CLM amplifier inputs. The recommended interconnect for the 4-axis CLM-LA (BE 1158), shows that the axis Drive Ready input is supplied with a +24 Vdc through the servo amplifier's Bb contacts. These contacts close when the servo amplifier has the proper condition and 3-phase power is applied. For more information about the Bb contacts, consult the manual for the servo amplifier being used.
42/72/A2/D2	Drive Runaway 1-4	<p>The "Drive Runaway Axis" error will occur if the direction of the axis encoder and direction of the the axis command polarity are not the same.</p> <ol style="list-style-type: none"> 1. The Direction Axis parameter must be compatible with the wiring of the encoder or with the command inputs E1/E2. 2. The data entered in the Encoder Data parameter does not correspond to the encoder used on the back of the axis motor. Check that the lines per revolution entered in the parameter matches the data on the encoder. 3. The RPM/Volts in the Drive Sensit. parameter does not correspond to the RPM/Volts on the axis amplifier's command input (E1/E2). 4. The axis moved without a command voltage being applied to the amplifiers command input (E1/E2), i.e., the axis was physically moved by means other than the motor.

HEX CODE #	ERROR MESSAGE	DESCRIPTION
43/73/A3/D3	Excess Pos Lag 1-4	<p>This error occurs when axis is commanded to a position but the axis servo system has excessive position lag.</p> <ol style="list-style-type: none"> 1. The axis servo amplifier does not have power applied. Verify that the Bb contacts on the axis servo amplifier are closed. For more information on conditions that are needed to apply power, consult the manual for the servo amplifier being used. 2. The Encoder Data parameter does not correspond to the encoder used on the back of the axis motor. Verify that the encoder value stored in parameter corresponds to the encoder mounted on the motor. 3. The RPM/Volt in the Drive Sensit. Axis parameter does not correspond to the RPM/Volts on the axis servo amplifier command input (E1/E2). 4. The Accel. Rate parameter value is too large. The motor is unable to accelerate at this rate. 5. The axis Amplifier Enable output is not connected to the Amplifier Enable (RF) input on the amplifier. 6. The axis encoder cable is not connected to the CLM encoder connector, or the axis motor encoder cable is not connected. 7. The axis encoder cable is wired incorrectly or is defective. 8. The axis encoder is defective. 9.The motor cannot turn because of a mechanical bind.
44/74/A4/D4	Abs. Encoder 1-4	<p>The condition occurs if the axis absolute encoder is not connected, or the data transmission to the CLM is interrupted or incorrect.</p> <ol style="list-style-type: none"> 1. The absolute encoder value stored in the Encoder Data parameter does not correspond to the encoder used on the back of the axis motor. Verify that the absolute encoder value stored in parameter corresponds to the absolute encoder value. 2. The axis absolute encoder cable is not connected to the CLM encoder connector or the axis absolute encoder cable is not connected to the axis motor. 3. The axis absolute encoder cable is defective or wired incorrectly. 4. The axis absolute encoder is defective.

HEX CODE #	ERROR MESSAGE	DESCRIPTION
45/75A5/D5	Abs. Range 1-4	<p>This error occurs if the maximum number of turns of the absolute encoder is exceeded.</p> <ol style="list-style-type: none"> 1. The absolute encoder value stored in the Encoder Data parameter does not correspond to the encoder used on the back of the axis motor. Verify that the absolute encoder value stored in parameter corresponds to the value shown on the absolute encoder. 2. The axis absolute encoder cable is defective or is wired incorrectly. 3. The axis absolute encoder is defective.
46/76/A6/D6	Min Travel Lmt 1-4	<p>This minimum travel error occurs in Automatic mode, if the value stored in the Minimum Travel Limit parameter is exceeded.</p> <ol style="list-style-type: none"> 1. The commanded position has exceeded the axis minimum travel limit. 2. Verify that the axis minimum travel limit parameter is correct.
47/77/A7/D7	Max Travel Lmt 1-4	<p>This maximum travel error occurs in Automatic mode, if the value stored in the Maximum Travel Limit parameter is exceeded.</p> <ol style="list-style-type: none"> 1. The commanded position has exceeded the axis maximum travel limit. 2. Verify that the axis maximum travel limit parameter is correct.
48/78A8/D8	Axis 1-4 Not Homed	<p>The error occurs if the user program encounters an absolute position command for an axis, but that axis has not yet been homed. Refer to chapter 3, section 3.2.5 for details.</p> <ol style="list-style-type: none"> 1. Verify that the axis parameters are correct. Axis can be homed in Manual or Automatic mode. Refer to chapter 4, Parameters for more information on axis homing. 2. Verify that the axis position command in the CLM user program is correct. Refer to chapter 5 for more information on the axis position commands.
49/79A9/D9	Marker Pulse 1?-4?	<p>The error occurs if the marker pulse of the axis 1/2 encoder is closer than 1/16 revolution to the homing switch cam. Refer to chapter 3, section 3.2.5 for details. Move the axis home limit switch a distance equal to or greater than 1/3 of the axis Feed Constant.</p>
4A/7AAA/DA	No Marker Pulse 1-4	<p>The error occurs if the axis marker pulse was not detected within one rotation of the encoder during the axis homing cycle, or if there is a continuous marker pulse, most likely as the result of a defective encoder. Refer to chapter 3, section 3.2.5 for details. Switch the marker wires at the encoder connector.</p>

A. APPENDIX A: LA PROGRAMMING NOTES

A.1 LA PROGRAMMING NOTES

This section is periodically updated with hints and examples of use and application of different programming commands.

Notes included in this section:

<u>Page</u>	<u>Description</u>
A-1	Axis Homing for the CLM
A-7	Aligning a Stegmann Absolute Encoder to a CLM

A.2 Axis Homing for the CLM

A.2.1 General

Homing of a linear or rotary axis is required if you need to do absolute positioning and are using an incremental position feedback device mounted on the motor or machine. The homing process, usually a series of back and forth moves to locate a reference point in relation to a mechanical setup, can be accomplished through a variety of methods when using the CLM control. This Programming Note describes several different homing methods in detail.

NOTE: In some applications, for mechanical or safety reasons, the axis cannot be homed after the process has started. For these applications, a Synchronous Serial Data (SSD) absolute encoder is required. Because an absolute device is capable of providing a known position relative to the machine's mechanical limits at all times, homing is not required.

A.2.2 Normal Homing

The CLM includes a homing routine suitable for most applications. This is described in detail in section 3.2.5 of the CLM manual. This routine, in conjunction with parameters and a home switch, provides a fast and easy way for the user to implement a homing sequence. This routine is activated by an input in manual mode or through a short series of commands in automatic mode. This home sequence in either mode starts with the selected axis performing the following steps.

1. The axis moves towards the home switch, at the velocity set in parameter Ax10 (V1), unless the axis is already on the switch.
2. After the home switch closes, the axis decelerates to a stop then reverses, moving off the switch at 25% of home velocity (V2) until the switch opens.
3. The axis then moves back toward the switch at 5000 pulses/sec (V3) until it senses both the home switch closure and the next occurrence of the marker pulse.
4. After the marker pulse is sensed, the axis decels to a stop, then returns toward the marker at 500 pulses/sec (V4). At the next occurrence of the marker pulse, the CLM records this as the zero position (a) and ramps to a stop (b).

```

0000 BCE 0005 21 1      Branch if Axis 1 Homed
0001 HOM 1              Home Axis 1 (fig. 1)
0002 ATS 21 1          Axis Homed output
0003 JMP 0005
0004 NOP
0005 BCE 0010 22 1     Branch if Axis 2 is Homed
0006 HOM 2              Home Axis 2 (fig.1)
0007 ATS 22 1          Axis 2 Homed output
0008 JMP 0010
0010 NOP                -- Start of Program --
0011 .
0012 .
    
```

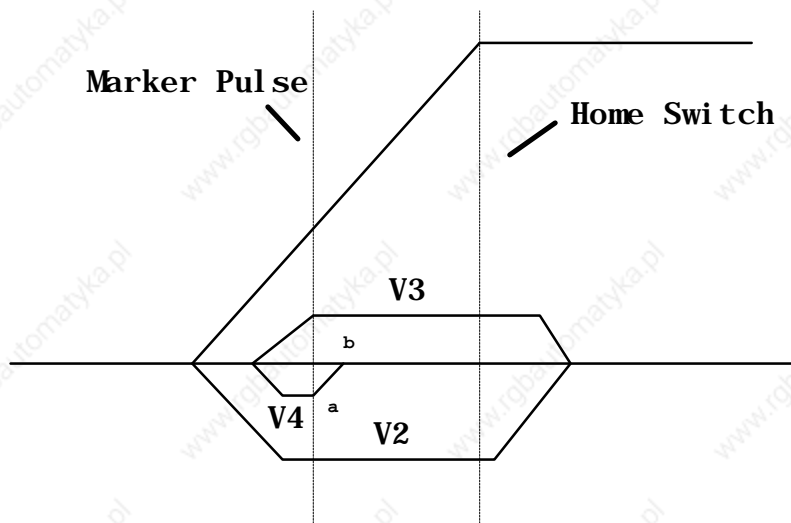

Figure A-1 Normal Homing Example

A.2.3 Homing Without Using the Homing Routine

In certain applications, it is not possible or desirable to use the standard homing sequence. For those instances, the user must define a homing sequence that satisfies the application, then write a short program routine to home the axes. With this method, the user can customize the homing routine to compensate for backlash, forward-moving-only applications, homing to a switch, or a variety of other needs.

A.2.4 Homing to a Switch

The following program sequences demonstrate several methods of homing to a switch. The first example is used to home an axis that cannot backup. The second example will provide a more accurate homing relative to the home switch, because the axis backs up to the switch. The third example is used if you must detect whether the axis is already on the home switch and must back off the switch before homing. Note that when customized homing routines are used, they are only executed in automatic mode, and the ability to home in manual mode is lost.

NOTE: The following examples assume the parameters and I/O are set as shown below. This can be freely modified to fit the particular application.

Inputs		Outputs	
1	Home switch, axis 1 (A112)	21	Axis 1 Homed (A112)
2	Home switch, axis 2 (A212)	22	Axis 2 Homed (A212)
		23	Axis 1 In Position (A106)
		24	Axis 2 In Position (A206)

Example 1: Illustrates the simplicity of creating a routine to home both axes in sequence (axis 1 first, then axis 2)). This routine is very useful for an application in which the axis should not back up while homing, such as a rotary table, conveyor or continuous web.

The program starts with blocks 0000 & 0001, used to detect if either axis has been previously homed. If not, the homing routines at blocks 0800 and 0806 will be executed as required. The homing program starts by branching to the CON command, which causes the program to wait until the home switch input is activated. The PBK command causes the axis to ramp to a stop at the current acceleration rate. The distance traveled past the switch is a function of both the selected velocity and the acceleration rate. The ATS command waits for the axis to be fully stopped (in position) before the CLA command is executed. The CLA command sets the axis position buffer to zero and sets the Homed flag high. This completes the homing process for either axis.

```

0000 BCA 0800 21 0 Branch if axis 1 has not been homed
0001 BCA 0806 22 0 Branch if axis 2 has not been homed
0002 NOP -- Start of Program --
0800 CON 1 1 -050 00 Sets axis 1 in (-) direction at 5% max. velocity
0801 AKN 1 1 Waits for axis 1 home switch to close
0802 PBK 1 Stops axis 1 motion (CON off could also be used)
0803 ATS 23 1 Waits for axis 1 to be in position
0804 CLA 1 Initializes axis 1 position buffer to zero
0805 JMP 0000
0806 CON 2 1 -050 00 Sets axis 2 in (-) direction at 5% max. velocity
0807 AKN 2 1 Waits for axis 2 home switch to close
0808 PBK 2 Stops axis 2 motion
0809 ATS 24 1 Waits for axis 2 to be in position
0810 CLA 2 Initializes axis 2 position buffer to zero
0811 JMP 0000

```

Example 2: Illustrates the use of the REF command, which causes the axis to back up to the point where the home switch was first closed before setting the position buffer to zero. Otherwise, it will function similar to example 1.

```

0800 REF 1 1 050 01 Sets axis 1 in REV direction, at 5% max. velocity waits for
home switch to close, then ramps to stop and reverses to the
point the switch first closed.
0801 ATS 23 1 Waits for axis 1 to be in position
0802 CLA 1 Initializes axis 1 position buffer to zero
0803 NOP
0804 JMP 0000
0805 NOP
0806 REF 2 1 050 02 Sets axis 2 in REV direction, at 5% max. velocity, waits for
home switch to close, then ramps to stop and reverses to the
point the switch first closed.
0807 ATS 24 1 Waits for axis 2 to be in position
0808 CLA 2 Initializes axis 2 position buffer to zero
0809 NOP
0810 JMP 0000

```

Example 3: Illustrates a routine that is very useful for applications in which the axis should not back up past the home switch. The program starts with blocks 0000 and 0001, used to detect if either axis has been previously homed. If not, the homing routines at blocks 0800 and 0810 will be executed as required. The homing program starts by branching to a BCE command that will branch to block 0805/0815 (core homing program) if the switch is not closed. If the home switch was closed, the program will drop down to the next three steps, comprised of a CON command which will cause the axis to move off the switch at a set velocity, an AKN command which causes the program to wait until the home switch input is opened, and the PBK which causes the axis to ramp to a stop.

The REF command starts the core homing program, used to locate the home switch. The axis moves toward the home switch at a set velocity until the switch is closed. After this, the axis ramps to a stop and then moves in the reverse direction, stopping at the point where the switch was first closed. The ATS command waits for the axis to be fully stopped (in position) before the CLA command is executed. The CLA command set the axis position buffer to zero and sets the Homed Flag high. This completes the homing process for a given axis.

0000	BCA	0800	21	0	Branch if axis 1 has not been homed
0001	BCA	0810	22	0	Branch if axis 2 has not been homed
0800	BCE	0805	1	0	Branch if axis 1 is not on the home switch
0801	CON	1	1	+050 00	Sets axis 1 in (+) direction at 5% max. velocity
0802	AKN	1	0		Waits for axis 1 home switch to open
0803	PBK	1			Stops axis 1 motion
0804	NOP				
0805	REF	1	1	050 01	Sets axis 1 in REV direction at 5% max. velocity, waits for home switch to close, then ramps to a stop and reverses to the point the switch first closed.
0806	ATS	23	1		Waits for axis 1 to be in position
0807	CLA	1			Initializes axis 1 position buffer to zero
0808	JMP	0000			
0809	NOP				
0810	BCE	0815	2	0	Branch if axis 2 is not on the home switch
0811	CON	1	1	+050 00	Sets axis 2 in the (+) direction at 5% max. velocity
0812	AKN	1	0		Waits for axis 2 home switch to open
0813	PBK	1			Stops axis 2 motion
0814	NOP				
0815	REF	2	1	050 02	Sets axis 2 in the (+) direction at 5% max. velocity, waits for home switch to close, then ramps to a stop and reverses to the point the switch first closed.
0816	ATS	24	1		Waits for axis 2 to be in position
0817	CLA	2			Initializes axis 2 position buffer to zero
0818	JMP	000			

A.2.5 Homing to the Marker Pulse

The CLM can be set to home directly to the next occurrence of the encoder marker pulse. This is very useful for single revolution applications where the rotating mechanisms are directly attached to the motor shaft (rotary knife, print drum). This type of operation is enabled when the home switch input is set to 00 in parameter Ax12. The homing routine can be activated by an input in manual mode, or through a short series of commands in automatic mode. This home sequence, in either mode, starts with the selected axis performing the following steps:

1. The axis moves in the desired direction (CW, CCW) at the velocity set in parameter Ax10, until the marker pulse is detected (V1).
2. The CLM notes where the marker pulse was sensed and continues to move in the same direction for approximately one revolution. The axis starts to decelerate prior to the next occurrence of the marker pulse, and stops at a position at or just past the marker pulse.

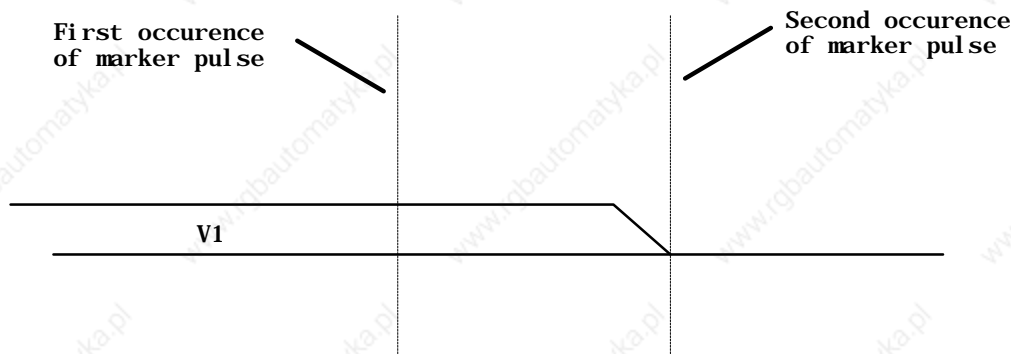

Figure A-2 Homing to the Marker Pulse Example

Homing routine at start of user program

```

0000 BCE 0005 21 1 Branch if Axis 1 is already homed
0001 HOM 1 Home Axis 1 (figure 2)
0002 ATS 21 1 Wait for Axis 1 Homed output
0003 JMP 0005
0004 NOP
0005 BCE 0010 22 1 Branch if Axis 2 is already Homed
0006 HOM 2 Home Axis 2 (figure 2)
0007 ATS 22 1 Wait for Axis 2 Homed output
0008 JMP 0010
0010 NOP -- Start of Program --
0011 .
0012 .
    
```

A.3 Aligning a Stegmann Absolute Encoder to a CLM

Tools required:

1. Standard Flathead Screwdriver
2. Stegmann Alignment Tool for Absolute Encoders (PN 243044)

Procedure:

1. Select Manual mode and apply 3-phase power to the servo system.
2. Press the Jog Forward or Reverse button until the axis reaches the desired home position.
3. Turn off three-phase power, but allow single-phase to be applied to the power supply. The +24V from the power supply is used to power the CLM and the absolute encoder.
4. Use a screw driver to remove the screw cap on the back of the encoder.
5. Look inside the absolute encoder and you should notice a cylinder with a 4-mm Allen-type screwhead.
6. Stegmann absolute encoders require the use of an alignment tool. See Figure 1 on the following page. The alignment tool has two handles and fits over the cylinder. The inside handle fits over the outside of the cylinder. The outside handle consists of a 4-mm Allen wrench which fits into the top of the cylinder.
7. Loosen the allen screw inside the absolute encoder by turning the outside handle counter-clockwise. A half-turn should be sufficient. By loosening the allen screw, the locking pin inside of the encoder is released. The locking pin is used to connect the absolute encoder to the coupling of the motor.
8. Observe the LP screen on the CLM. By turning the inside handle in the clockwise or counter-clockwise direction, the LP screen position should count up or down. Turn the inside handle of the alignment tool until the LP screen displays the desired home position. Typically, the desired position is +0.000.
9. When the desired home position has been reached, turn the outside handle in the clockwise direction until the locking pin is securely tightened into the coupling.

CAUTION: Do not overtighten the locking pin. This could result in breaking the encoder coupling.

10. Remove the alignment tool and reapply the screw cap, using the screwdriver.

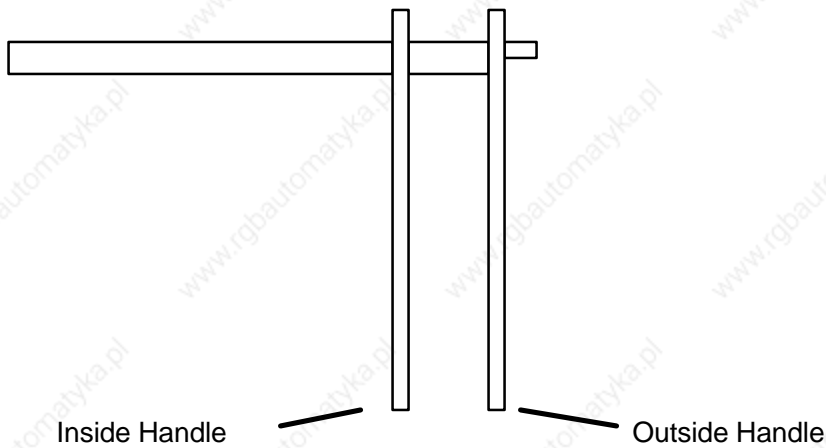

Figure A-3 Stegmann Tool

1. The outside handle is used to loosen the connection between the motor and the absolute encoder.
2. The inside handle is used to set the position of the absolute encoder.

B. DOCUMENTATION, EKITS AND CABLES

B.1 Manuals and Drawings

The CLM-01.3-A is used as part of a system, operating with servo amplifiers (one for each axis enabled, 1-4), power supply, and servo motors.

For detailed information and specifications on these devices, refer to the Indramat technical publications listed below. Contact Indramat if you require additional information.

Manual Title	Publication Number
TVM/KDV AC Power Supplies	IA 74156
TDM/KDS AC Servo Amplifiers	IA 74145
TDM Amplifier Drive Selection List	IA 74122
KDS Amplifier Drive Selection List	IA 74142
TDM/KDS User Manual	IA 74725
TVM/KDV User Manual	IA 74727
TVD 1.2 User Manual	IA 74791
MotionManager™ Application Software	IA 74733
Station Operator Terminal (SOT)	IA 74783
Screen Manager Software	IA 74784

Drawings	Publication Number
4-axis CLM-01.3-A/SOT/TVD/TDM/MAC	BE 1158
Overtravel Hardware Limit Sw. Interconnect	BE 1127
CLM Outline/Mounting Dimensions	109-0736-3001-01A

B.2 CLM-01.3 E-Kits

E-Kit Type	"X" Connectors Supplied													
E1-CLM	1		3	4	5	6	7							
E2-CLM	1*		3	4	5	6	7							
E3-CLM		2			5	6	7							
E4-CLM					5	6	7							
E5-CLM					5		7							
E6-CLM	1	2	3	4	5	6	7							
E7-CLM	1*	2	3	4	5	6	7							
E8-CLM	1		3	4	5	6	7	11	12	13				
E9-CLM	1	2	3	4	5	6	7	11	12	13				
E10-CLM	1*		3	4	5	6	7	11	12	13				
E11-CLM	1*	2	3	4	5	6	7	11	12	13				
E12-CLM	1	2	3	4	5	6	7				19	20	21	22
E13-CLM	1	2	3	4	5	6	7	11	12	13	19	20	21	22
E14-CLM					5	6	7				19			
E15-CLM					5		7				19			
E16-CLM	1*	2	3	4	5	6	7				19	20	21	22
E17-CLM	1*	2	3	4	5	6	7	11	12	13	19	20	21	22

NOTE: These E-kits supply connector shells only. If you need connector shells with cables, refer to the SKS numbers for cable sets. (See next page)

* Denotes two cable outputs from one connector shell, for measuring wheel.

B.3 CLM 01.3A Cable Sets

Set Type	CLM "X" Connectors										Total Axes	Incr Axes	Incr. with M.W.	Abs. Axes	Abs. with M.W.	Exp. I/O
SKS 001	1		3	4							1	1				
SKS002	1*		3	4							1	1	1			
SKS003	1		3	4							1			1		
SKS004	1	2	3	4							2	2				
SKS005	1*	2	3	4							2	2	1			
SKS006	1	2	3	4							2			2		
SKS007	1	2	3	4							2	1		1		
SKS008	1*	2	3	4							2	1	1	1		
SKS011	1		3	4	11	12	13				1	1				1
SKS012	1*		3	4	11	12	13				1	1	1			1
SKS013	1		3	4	11	12	13				1			1		1
SKS014	1	2	3	4	11	12	13				2	2				1
SKS015	1*	2	3	4	11	12	13				2	2	1			1
SKS016	1	2	3	4	11	12	13				2			2		1
SKS017	1	2	3	4	11	12	13				2	1		1		1
SKS018	1*	2	3	4	11	12	13				2	1	1	1		1
SKS019	1*	2	3	4	11	12	13				2			2	1	1
SKS020																
SKS021	1*		3	4							1			1	1	
SKS022	1*	2	3	4	11	12	13				1			1	1	1
SKS023	1	2	3	4	11	12	13				2	1		1	1	1
SKS035	1	2	3	4				20	21	22	4	2		2		
SKS036	1	2	3	4				20	21	22	4			4		
SKS037	1	2	3	4	11	12	13	20		22	3	3				1
SKS038	1	2	3	4				20	21	22	4	4				
SKS039	1	2	3	4	11	12	13	20	21	22	4	4				1
SKS040	1	2	3	4				20		22	3	3				
SKS041	1*	2	3	4				20		22	3	1	1	2		
SKS042	1*	2	3	4				20		22	3	3	1			
SKS043	1	2	3	4				20		22	3			3		

Cable sets "SKS 001 - 008" are for a CLM 01.3 with 2 axes.

Cable sets "SKS 011 - 023" are for a CLM 01.3 with expansion I/O.

Cable sets "SKS 035 - 043" are for a CLM with 4 axes.

* Denotes two cables from one connector shell.

C. CLM DISPLAY SCREEN MAP

This page is included for illustrative purposes only. Refer to chapter 2, section 2.3, for description of using this map, and how to interpret the information on the screens of the CLM control panel display.

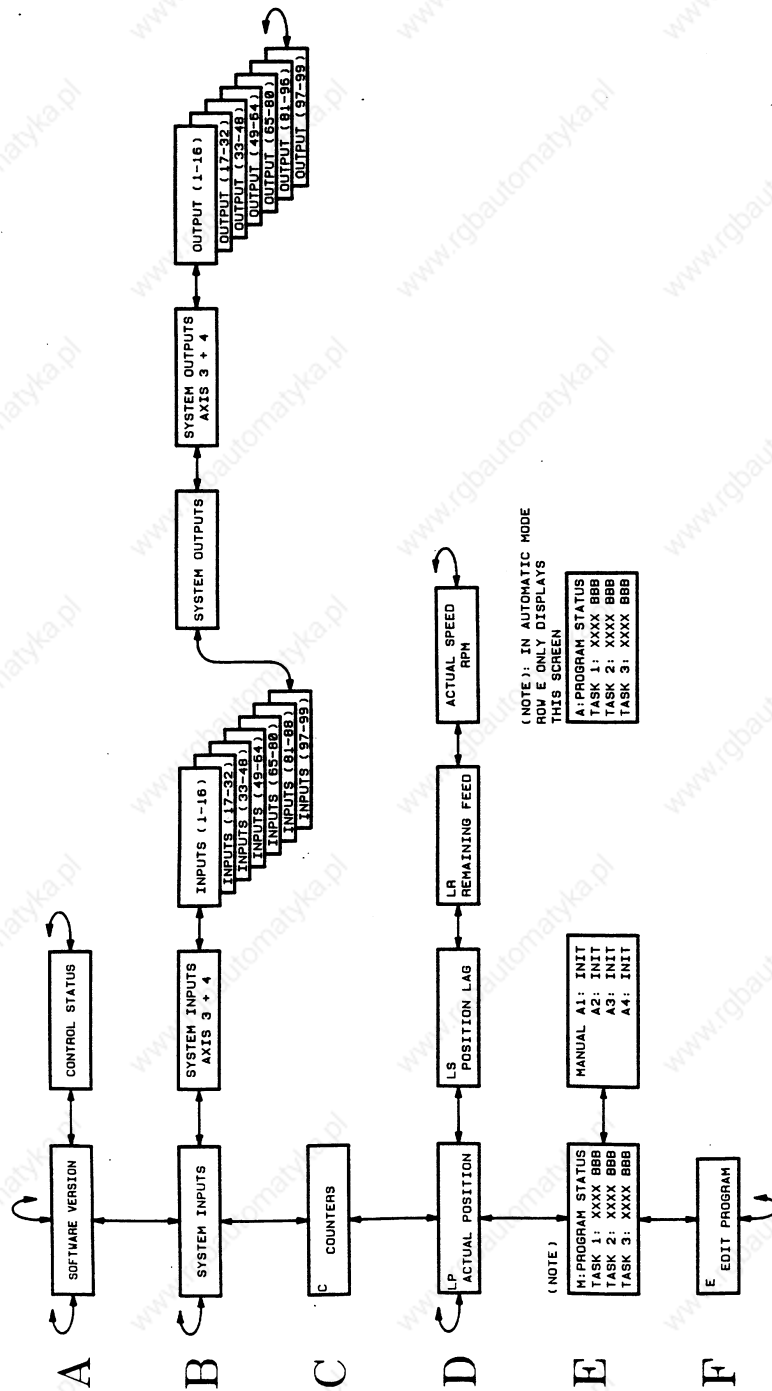

D. CLM PROGRAM COMMANDS/FORMAT

The pages in this appendix provide a quick reference to the program commands and their format.

D.1 CLM-01.3-A / LA01.3-01.x Alphabetical Listing of Program Command Formats

ACC _ 1 _ _ 9 9 9 _ _ _ _ _	Acceleration Change
AEA _ 0 7 _ _ 1 _ _ _ _ _	Auxiliary Output ON/OFF
AKN _ 0 7 _ _ 1 _ _ _ _ _	Acknowledge Single Input
AKP _ 0 _ _ _ _ 0 0 0 1 1 1 2 2 2 0	Parallel Acknowledgment Input
APE _ 0 _ _ _ _ 0 0 0 1 1 1 2 2 2 0	Parallel Outputs ON/OFF
APJ _ 1 2 3 4 4 _ 0 0 0 1 1 1 2 2 2 0	Set Parallel Outputs, then Jump
ATS _ 0 7 _ _ 1 _ _ _ _ _	Output State Monitor
BAC _ 1 2 3 4 _ + 1 2 3 4 _ 1 2 3 4 5	Branch And Count
BCA _ 1 2 3 4 _ 0 7 _ _ 1 _ _ _ _	Output-Dependent Conditional Branch
BCB _ 1 2 3 4 2 0 _ _ 1 _ _ _ _	Binary Input Conditional Branch
BCD _ 1 2 3 4 2 0 _ _ _ _ _	BCD-Dependent Conditional Branch
BCE _ 1 2 3 4 _ 0 7 _ _ 1 _ _ _ _	Input-Dependent Conditional Branch
BIO _ 1 2 3 4 1 _ 0 0 0 1 1 1 2 2 2 0	Branch Input/Output Compare
BMB _ 1 2 3 4 _ 1 0 _ 0 4 _ 8 _ _ _ _	Binary Output-Dependent Conditional Branch
BPA _ 1 2 3 4 1 _ 0 0 0 1 1 1 2 2 2 0	Branch on Parallel Outputs
BPE _ 1 2 3 4 1 _ 0 0 0 1 1 1 2 2 2 0	Branch on Parallel Inputs
BPT _ 1 2 3 4 2 _ + 1 2 3 4 5 . 6 7 8	Branch If Position Has Been Reached
BZP _ 1 2 3 4 2 _ + 1 2 3 4 5 . 6 7 8	Branch if Target Position Exceeds Position Limit
CID _ 1 2 3 4 1 _ 0 _ + 1 2 3 4 5 6 7	Change Instruction Data
CIO _ 0 _ 0 1 _ 2 3 _ 4 _ _ _ _ _	Copy Input/Output to Output
CLA _ 1 _ _ _ _ _ _ _ _ _ _	Clear Axis (Absolute Encoder Value)
CLC _ 1 4 5 6 _ _ _ _ _ _ _ _	Clear Counter
COC _ 1 _ 0 7 _ 0 0 1 1 2 2 _ + 3 6 0	Cam Output Control
CON _ 1 _ _ 0 _ + 9 9 9 _ 0 7 _ _ _ _	Continuous Operation (ON/OFF)
COU _ + 1 2 3 4 5 _ 1 2 _ 1 2 3 4 5 6	Count
CST _ 1 _ 1 _ _ _ _ _ _ _ _ _ _	Change Subroutine Stack - Pointer
FAK _ 1 _ _ 1 . 2 3 4 5 6 7 _ _ _ _ _	Factor All Motions (All Positions by X)
FMS _ 1 _ 1 2 3 . 4 _ 0 1 _ 0 1 _ 0 1	Follow Master
FOL _ 1 _ _ 2 _ _ 1 . 2 3 4 5 6 7 _ _	Axis Synchronization (on/off)
FUN _ 2 _ 2 _ 1 _ 2 2 2 2 _ _ _ _ _	Functions
HOM _ 1 _ _ _ _ _ _ _ _ _ _	Home Axis
JMP _ 1 2 3 4 _ _ _ _ _ _ _ _ _ _	Unconditional Jump (to block)
JSR _ 1 2 3 4 _ _ _ _ _ _ _ _ _ _	Jump to Subroutine
JST _ 1 2 3 4 _ _ _ _ _ _ _ _ _ _	Jump and Stop
JTK _ 1 2 3 4 _ 1 _ _ _ _ _ _ _ _	Jump in Task (task interrupt)
KDI _ 2 0 0 0 _ _ 1 0 0 0 _ _ 1 _ _ _	Copy Position Difference

NOP _____ Blank Block (no operation)
PBK _ 1 _____ Position Break
POA _ 1 _ + 1 2 3 4 5 . 6 7 8 _ 9 9 9 Position Absolute Feed
POI _ 1 _ + 1 2 3 4 5 . 6 7 8 _ 9 9 9 Position Incremental Feed
POM _ 1 _ 0 _ 1 _____ Incremental Feed to Decade Switch Position
PSA _ 1 _ + 1 2 3 4 5 . 6 7 8 _ 9 9 9 Absolute Feed with Position Acknowledgment
PSI _ 1 _ + 1 2 3 4 5 . 6 7 8 _ 9 9 9 Incremental Feed with Position Acknowledge
PSM _ 1 _ 0 _ 1 _____ Feed to Decade Switch Pos. w/ Acknowledge
PST _ 1 _ _ 0 1 _ + 1 2 3 4 5 . 6 7 8 Position Test
REF _ 1 _ 0 _ 9 9 9 _ 1 2 _____ Detect Registration Mark Input
REP _ 1 2 3 4 _ 1 _ 1 2 3 4 5 . 6 7 8 Registration Search Limit Branch
RMI _ 0 _ 0 1 _____ Registration Mark Interrupt
RSV _ 1 _ 0 0 0 _ 1 0 0 0 0 0 _____ Restart Vector
RTS _____ Return from Subroutine
SAC _ 1 _ 0 _ _ + 1 2 3 4 5 . 6 7 8 Set Absolute Counter
SIN _ 1 _ _ 0 7 _ 1 2 . 3 4 5 _ 1 2 3 Sine Oscillation
SO1 _ 1 _ 1 _ 0 7 _ 1 2 3 4 _____ Scanning of Inputs and Modifying a Length
SO2 _ 1 _ + 1 2 3 . 4 5 6 _ 2 _____ Position Correction via the Analog Input
STH _ 0 _ _ 0 0 0 0 _____ Send to Host
VCA _ 1 _ + 1 2 3 4 5 . 6 7 8 _ 9 9 9 Velocity Change Absolute
VCC _ 1 _ _ 1 2 3 4 5 . 6 7 8 _ 9 9 9 Velocity Change
VEO _ 1 _ 1 _ 1 _ 9 9 9 _ 0 _____ Velocity Override Command
WAI _ 0 1 . 0 0 _____ Time Delay (Wait)
WRI _ 1 2 3 4 _ 0 1 1 _____ Write in Absolute Position (teach command)

E. PARAMETER INPUT SHEETS

E.1 Axis 1 Parameter Input Sheet

Description	Parameter #	Parameter Data
MAX VELOCITY	A100	-----
JOG VELOCITY	A101	-----
ACCEL RATE	A102	-----
POSITION GAIN	A103	-----
ENC LINES/REV	A104	-----
ABSOLUTE DATA	A105	-----
POSITION TOL	A106	-----
POS PRE-SIGNAL	A107	-----
FEED CONSTANT	A108	-----
DIRECTION	A109	-----
HOMING SETUP	A110	-----
HOMING OFFSET	A111	-----
HOMING ACK	A112	-----
MIN TRAVEL	A113	-----
MAX TRAVEL	A114	-----
SPECIAL FUNCT	A115	-----
ROTARY TABLE	A116	-----
KNEE POINT	A117	-----
POLUM. MAX	A118	-----
POLUM. MIN	A119	-----
FEED ANGLE MON	A120	-----
DRV INPUT SEN	A121	-----
MONITOR WINDOW	A122	-----
FOLLOW/SYNC MW	A123	-----
FREE	A124	-----
FREE	A125	-----

NOTE: The placement of the decimal (2 or 3 decimal places) is determined by the setting of Parameter B007.

E.2 Axis 2 Parameter Input Sheet

Description	Parameter #	Parameter Data
MAX VELOCITY	A200	-----
JOG VELOCITY	A201	-----
ACCEL RATE	A202	-----
POSITION GAIN	A203	-----
ENC LINES/REV	A204	-----
ABSOLUTE DATA	A205	-----
POSITION TOL	A206	-----
POS PRE-SIGNAL	A207	-----
FEED CONSTANT	A208	-----
DIRECTION	A209	-----
HOMING SETUP	A210	-----
HOMING OFFSET	A211	-----
HOMING ACK	A212	-----
MIN TRAVEL	A213	-----
MAX TRAVEL	A214	-----
SPECIAL FUNCT	A215	-----
ROTARY TABLE	A216	-----
KNEE POINT	A217	-----
POLUM. MAX	A218	-----
POLUM. MIN	A219	-----
FEED ANGLE MON	A220	-----
DRV INPUT SEN	A221	-----
MONITOR WINDOW	A222	-----
FOLLOW/SYNC MW	A223	-----
FREE	A224	-----
FREE	A225	-----

NOTE: The placement of the decimal point (2 or 3 decimal places) is determined by the setting of Parameter B007.

E.3 Axis 3 Parameter Input Sheet

Description	Parameter #	Parameter Data
MAX VELOCITY	A300	-----
JOG VELOCITY	A301	-----
ACCEL RATE	A302	-----
POSITION GAIN	A303	-----
ENC LINES/REV	A304	-----
ABSOLUTE DATA	A305	-----
POSITION TOL	A306	-----
POS PRE-SIGNAL	A307	-----
FEED CONSTANT	A308	-----
DIRECTION	A309	-----
HOMING SETUP	A310	-----
HOMING OFFSET	A311	-----
HOMING ACK	A312	-----
MIN TRAVEL	A313	-----
MAX TRAVEL	A314	-----
SPECIAL FUNCT	A315	-----
ROTARY TABLE	A316	-----
KNEE POINT	A317	-----
POLUM. MAX	A318	-----
POLUM. MIN	A319	-----
FEED ANGLE MON	A320	-----
DRV INPUT SEN	A321	-----
MONITOR WIND	A322	-----
FOLLOW/SYNC MW	A323	-----
FREE	A324	-----
FREE	A325	-----

NOTE: The placement of the decimal point (2 or 3 decimal places) is determined by the setting of Parameter B007.

E.4 Axis 4 Parameter Input Sheet

Description	Parameter #	Parameter Data
MAX VELOCITY	A400	-----
JOG VELOCITY	A401	-----
ACCEL RATE	A402	-----
POSITION GAIN	A403	-----
ENC LINES/REV	A404	-----
ABSOLUTE DATA	A405	-----
POSITION TOL	A406	-----
POS PRE-SIGNAL	A407	-----
FEED CONSTANT	A408	-----
DIRECTION	A409	-----
HOMING SETUP	A410	-----
HOMING OFFSET	A411	-----
HOMING ACK	A412	-----
MIN TRAVEL	A413	-----
MAX TRAVEL	A414	-----
SPECIAL FUNCT	A415	-----
ROTARY TABLE	A416	-----
KNEE POINT	A417	-----
POLUM. MAX	A418	-----
POLUM. MIN	A419	-----
FEED ANGLE MON	A420	-----
DRV INPUT SEN	A421	-----
MONITOR WIND	A422	-----
FOLLOW/SYNC MW	A423	-----
FREE	A424	-----
FREE	A425	-----

NOTE: The placement of the decimal point (2 or 3 decimal places) is determined by the setting of Parameter B007.

E.5 "B" System Parameters Input Sheet

Description	Parameter #	Parameter Data
ENABLE AXIS 2	B000	-----
ENABLE AXIS 3	B001	-----
ENABLE AXIS 4	B002	-----
SERIAL INTERFACE	B003	-----
SERIAL INTERFACE	B004	-----
MEMORY DISPLAY	B005	-----
START TASK 2 & 3	B006	-----
VARIATIONS	B008	-----
FREE	B009	-----
FREE	B010	-----
MANUAL VECTOR	B011	-----
INTERRUPT VECTOR	B012	-----
ANALOG INPUT	B013	-----
RESTART VECTOR	B014	-----
CYCLE TIME	B015	-----
MW ENCODER 1	B016	-----
MW ENC'R LINES/REV	B017	-----
MW FEED CONSTANT	B018	-----
MEAS WHEEL OFFSET	B019	-----
FREE	B020	-----
FREE	B021	-----
FREE	B022	-----
FREE	B023	-----

F. DRAWINGS AND SCHEMATICS

CAUTION: The drawings in this Appendix are included for illustrative purposes only and are subject to change without notice. Check with Indramat to be sure you are working with the latest drawings prior to installing, wiring and powering equipment.

F.1 Encoder Input Connections, Axis 1

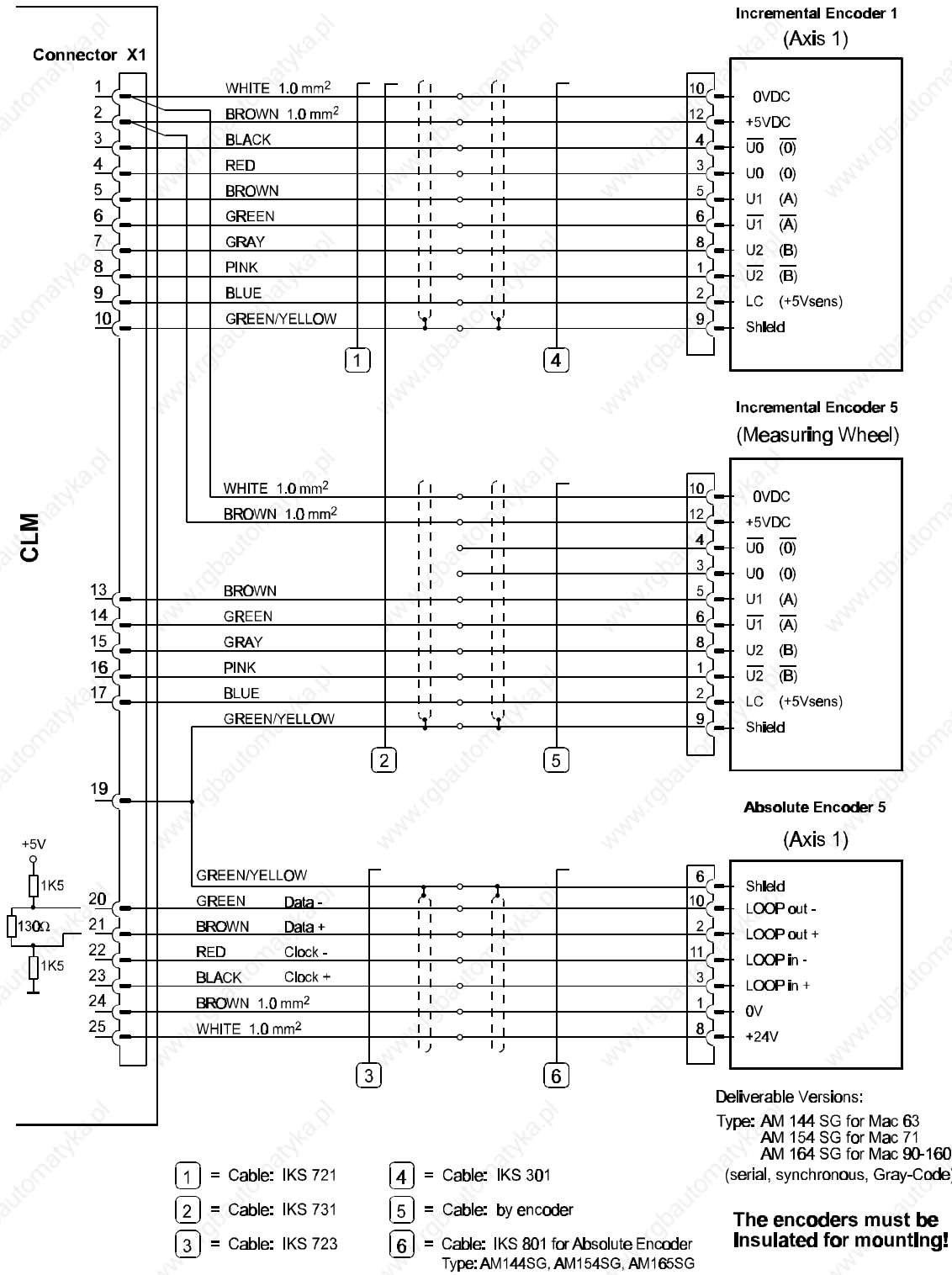

Figure F-1 Encoder, Axis 1 (Incremental Encoder, Absolute Encoder, Measuring Wheel)

F.2 Encoder Input Connections, Axis 2

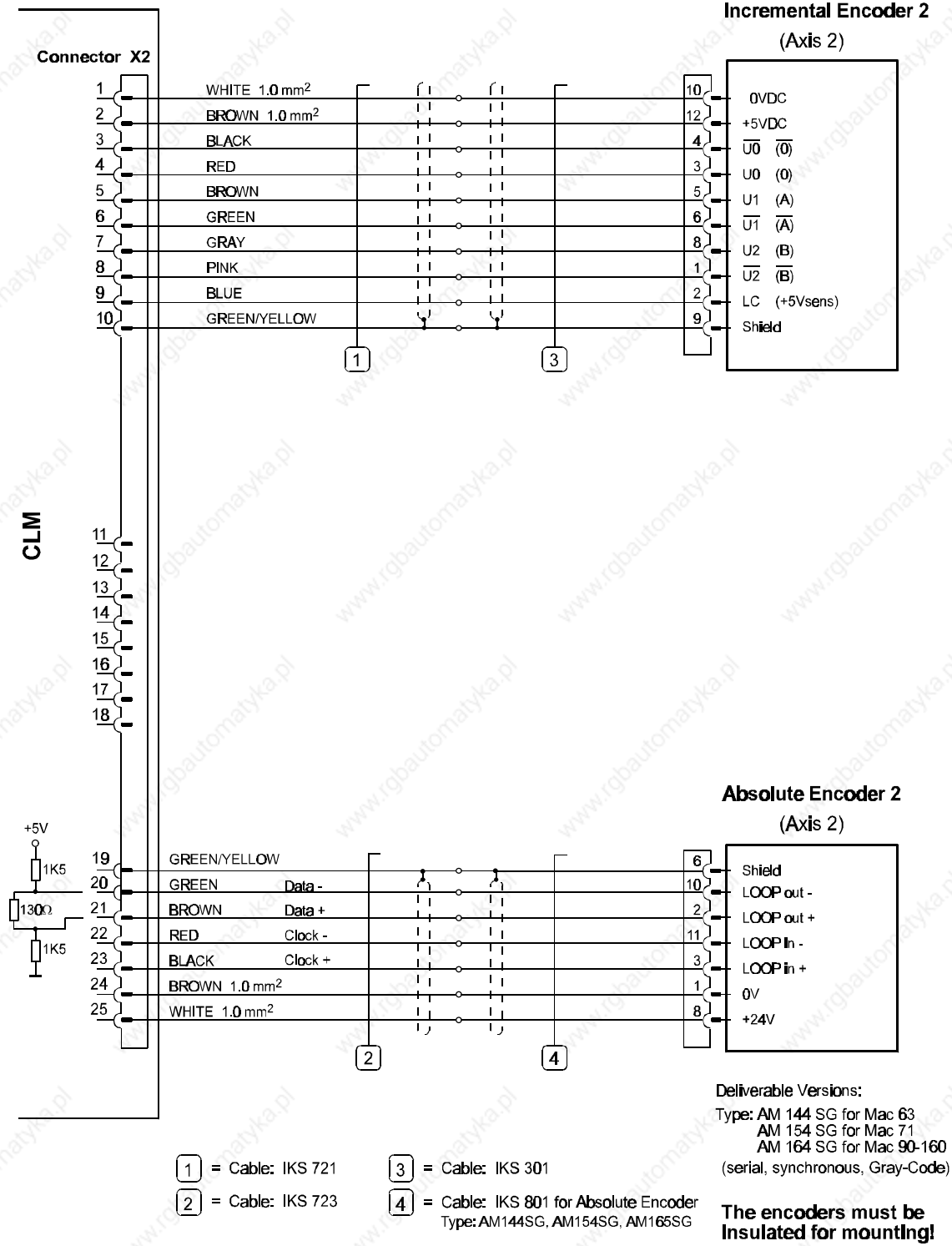
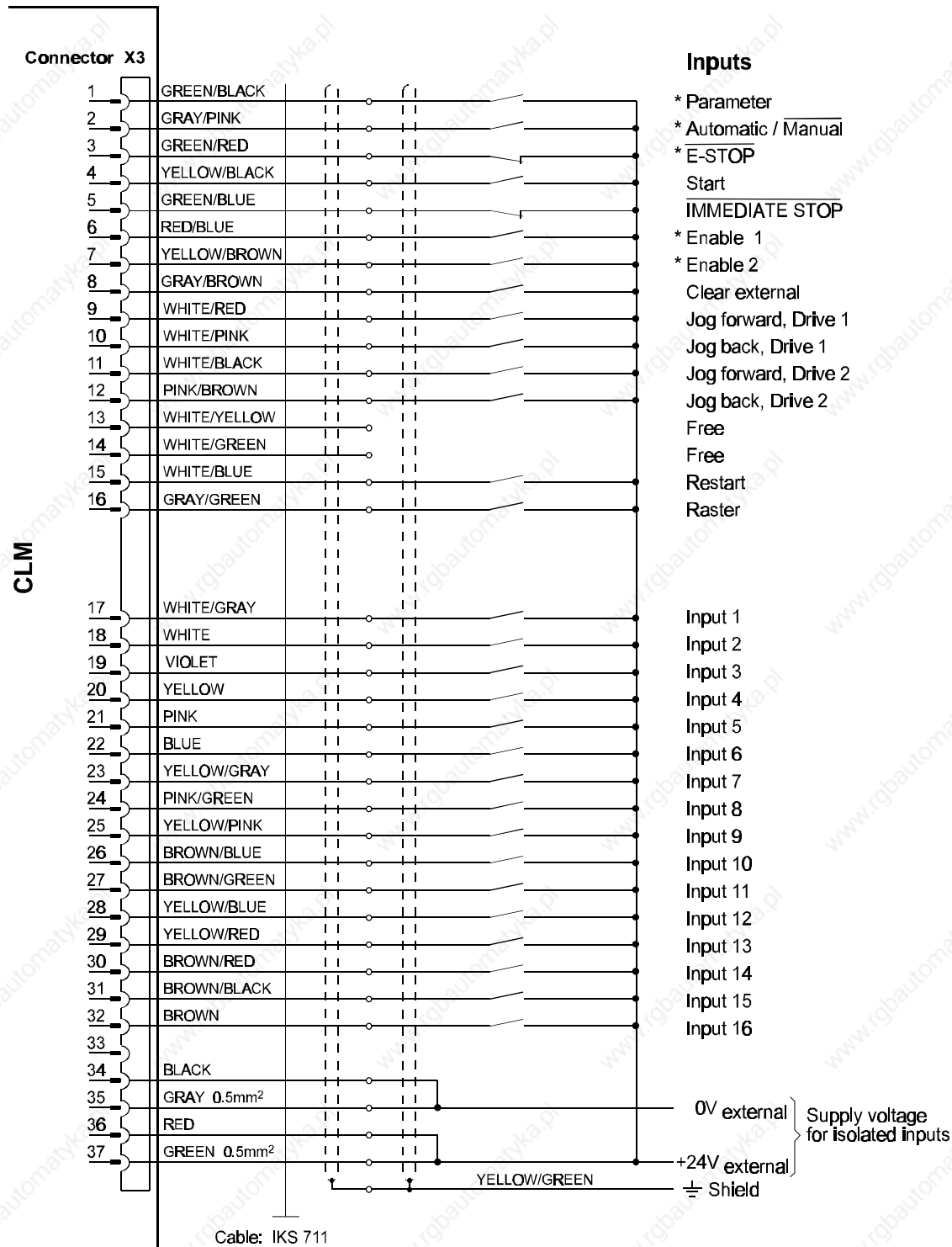

Fig. 9.3. Enc. A2 CLM

Figure F-2 Encoder, Axis 2 (Incremental Encoder, Absolute Encoder)

F.3 Input Connections



* = the necessary signals must be constant (no intermittent signals) !

Fig. 9.4. Inp. CLM

Figure F-3 System Inputs / Inputs 1-16

F.4 Output Connections

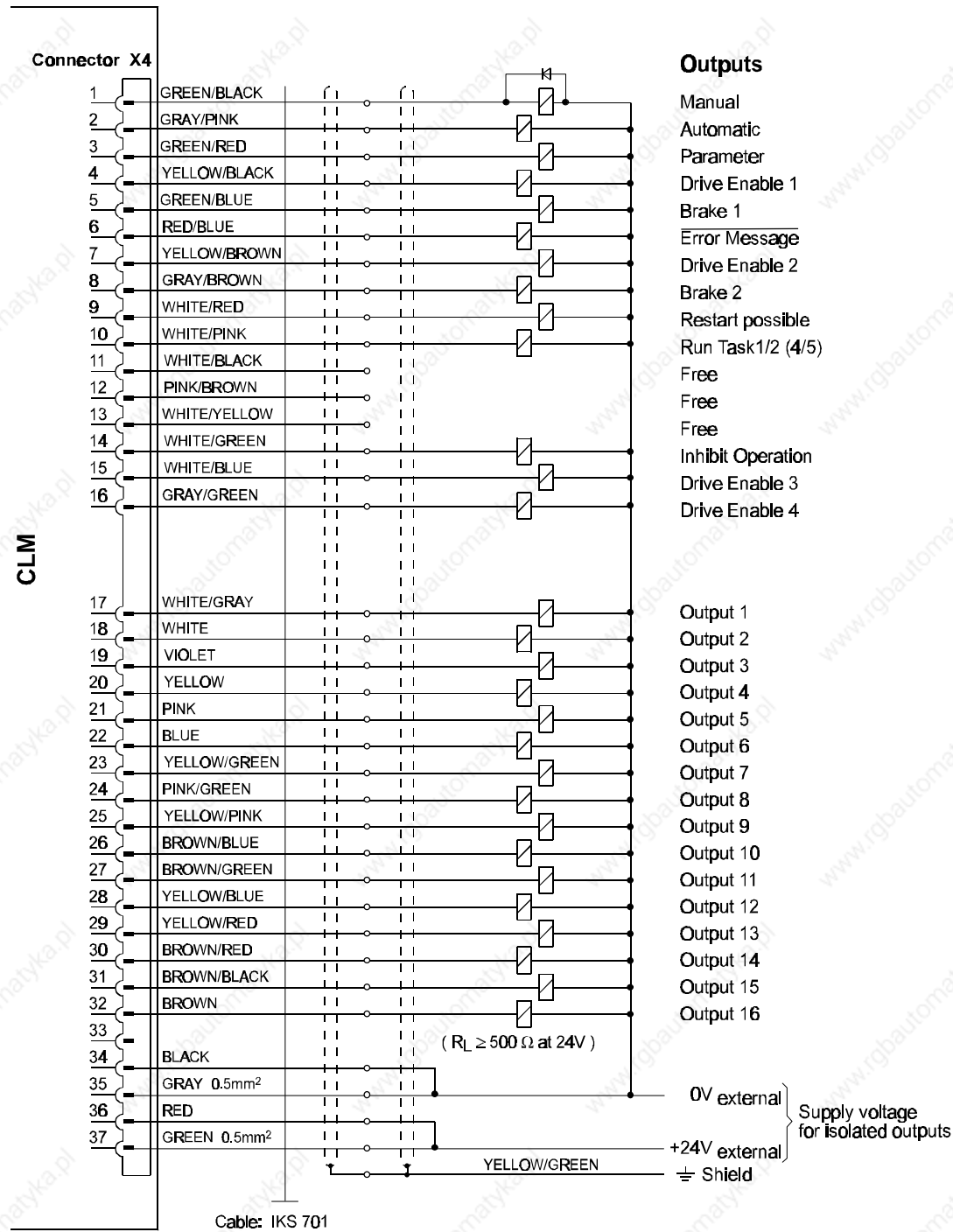

Fig. 9.5. Outp. CLM

Figure F-4 System Outputs / Outputs 1-16

F.5 Power Supply Connections

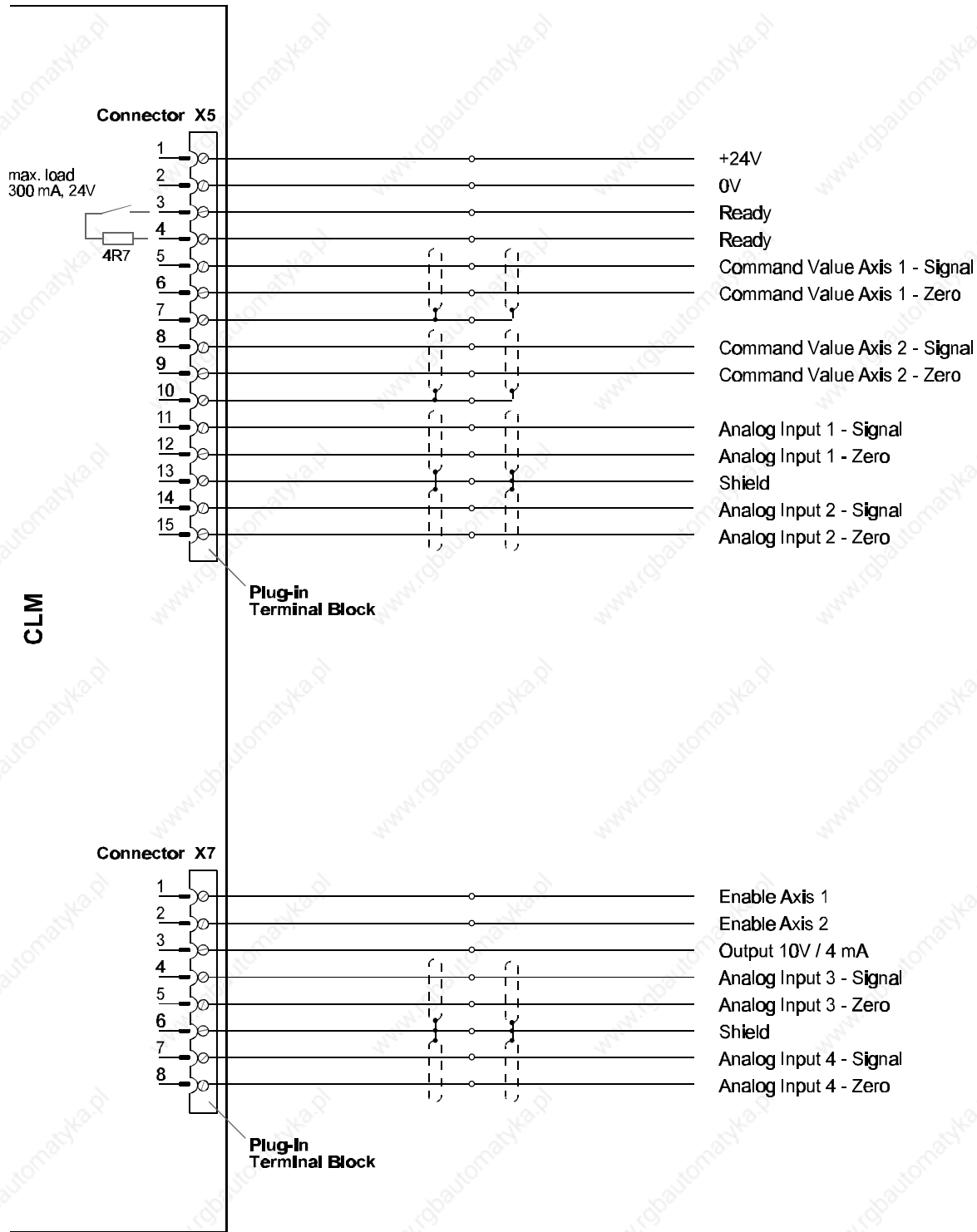

Fig. 9.6. Supply CLM

Figure F-5 Command Value for Axes 1 and 2, Drive Enable, Analog Inputs

F.6 Interface Connections

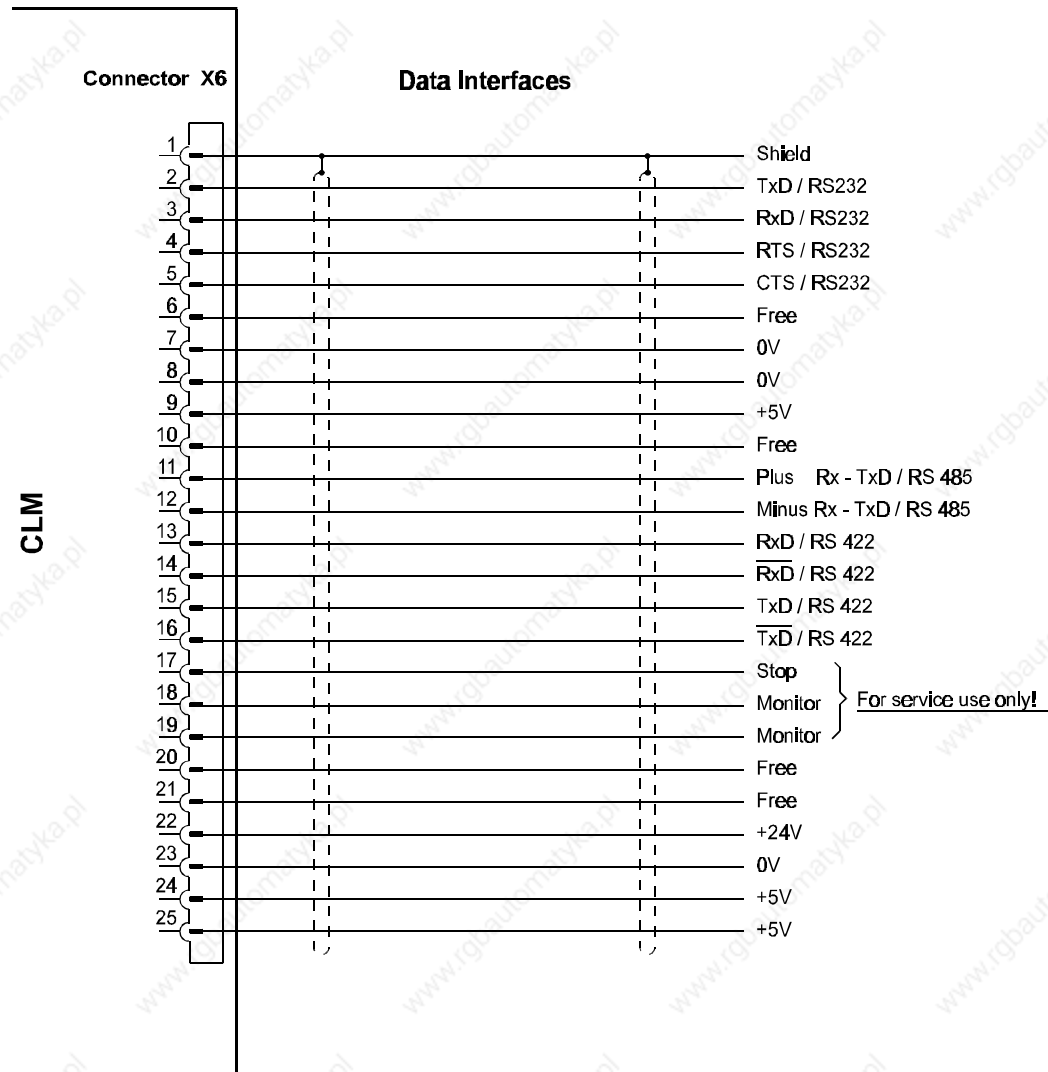
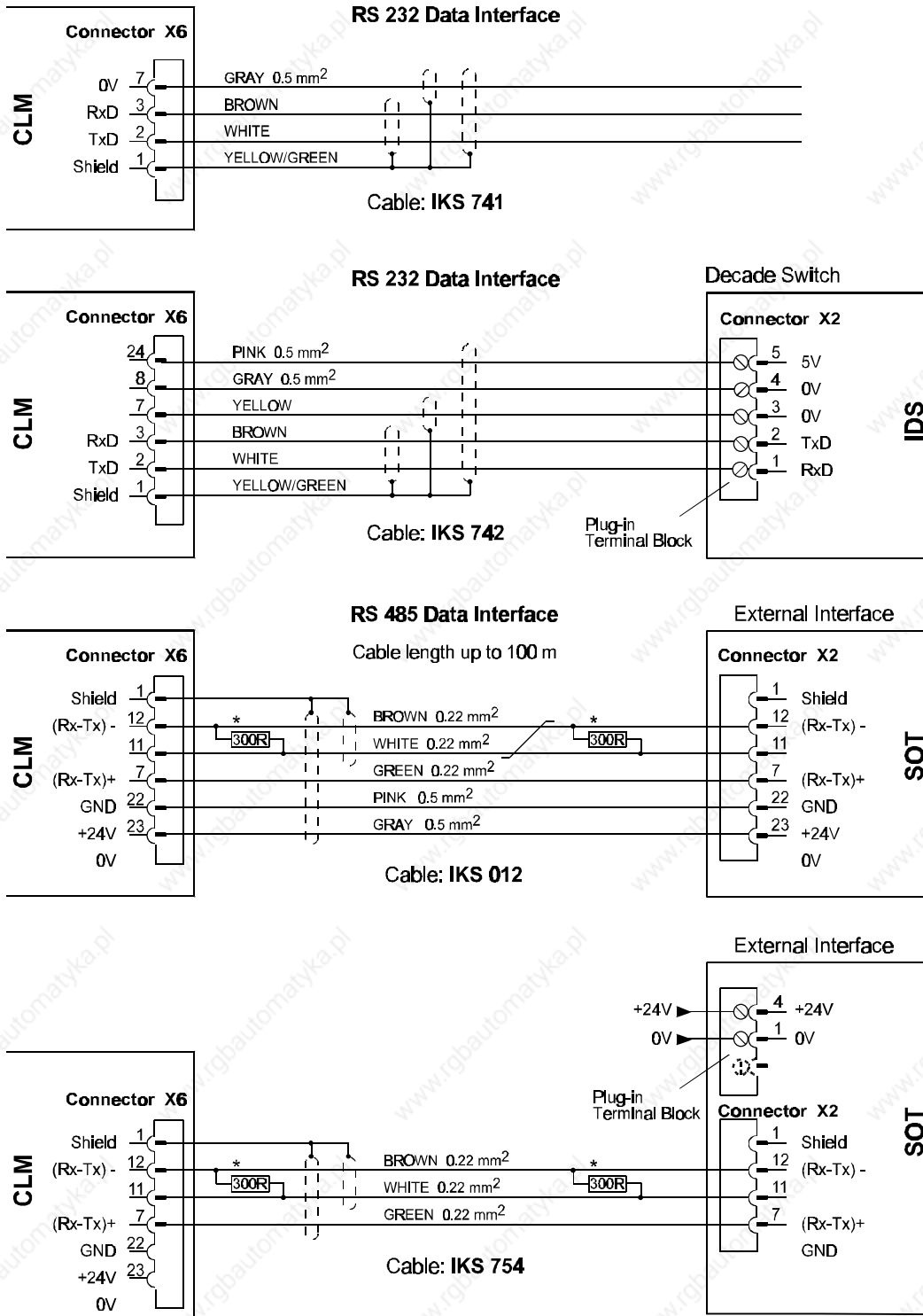

Fig. 9.7. Interf. CLM

Figure F-6 Data Interfaces

F.7 RS 232 / RS 485 Interface Connections



* = Both cable ends should have a resistance of 300R.

Fig. 9.8 RS485 CLM

Figure F-7 RS 232 / RS 485 Data Interfaces

F.8 RS 485 (w / SOT) Interface Connections

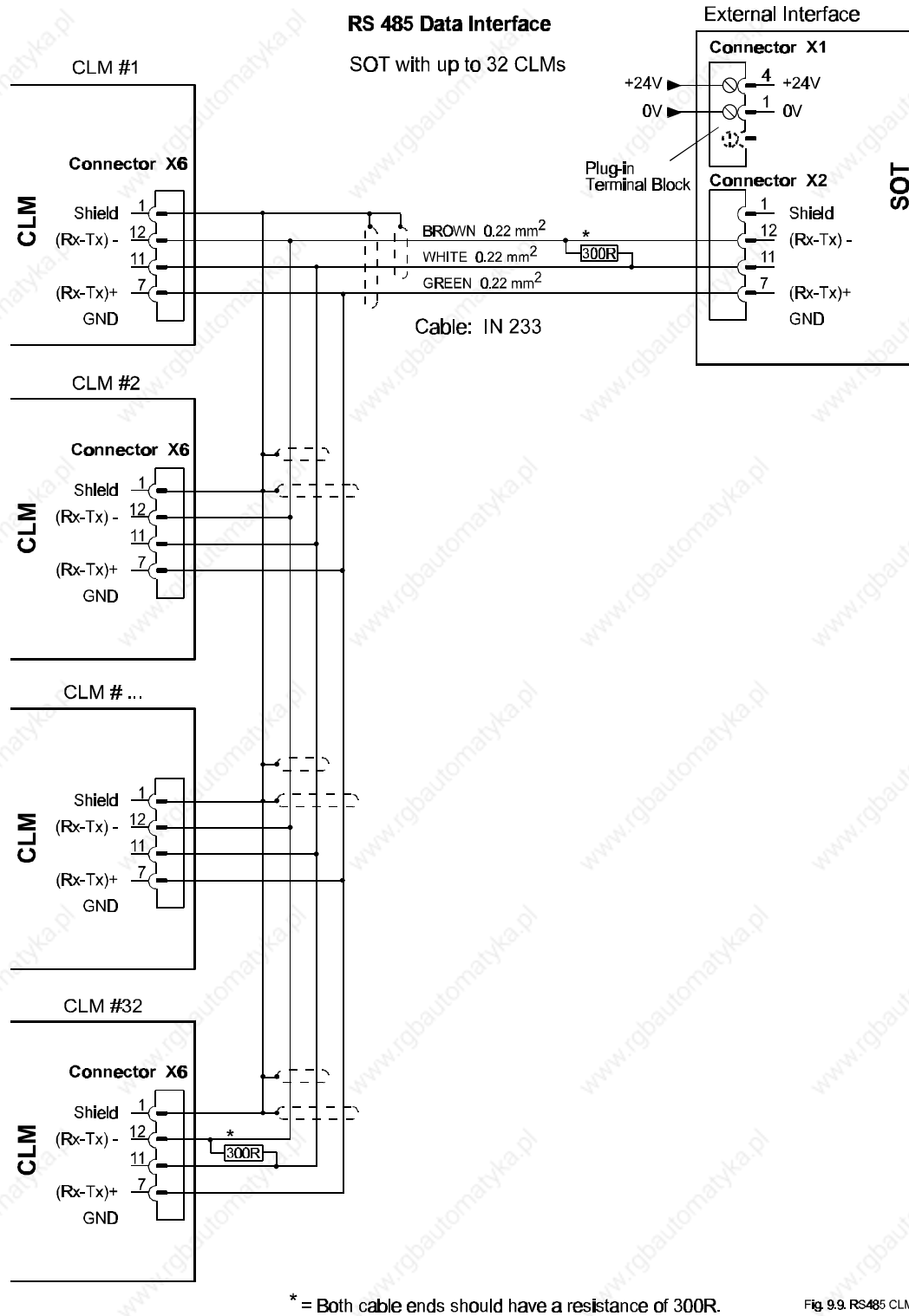

Figure F-8 SOT with up to 32 CLM Stations

F.9 Input Connections

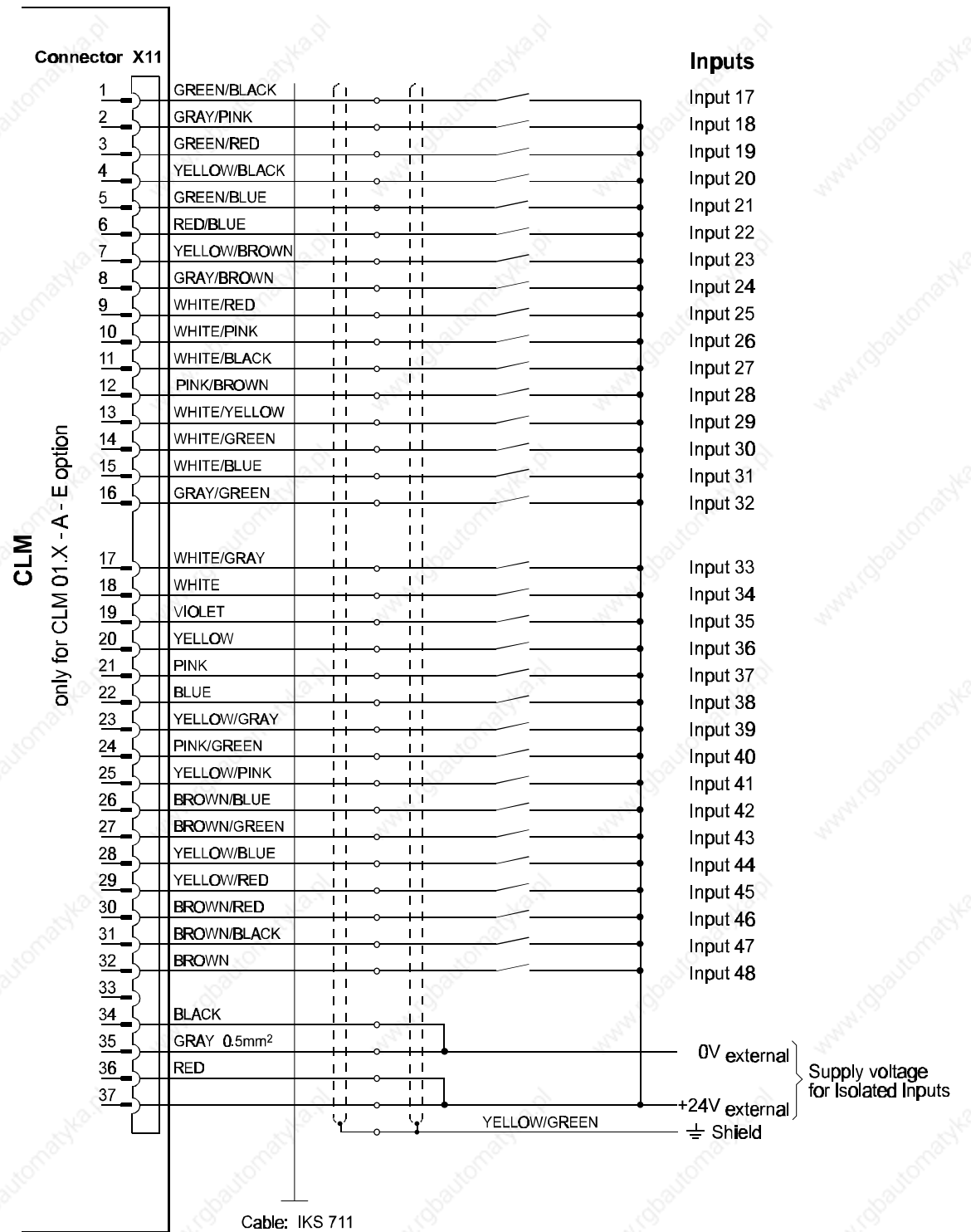

Fig. 9.10. Inp. CLM

Figure F-9 Inputs 17-48 (expanded)

F.10 Input Connections

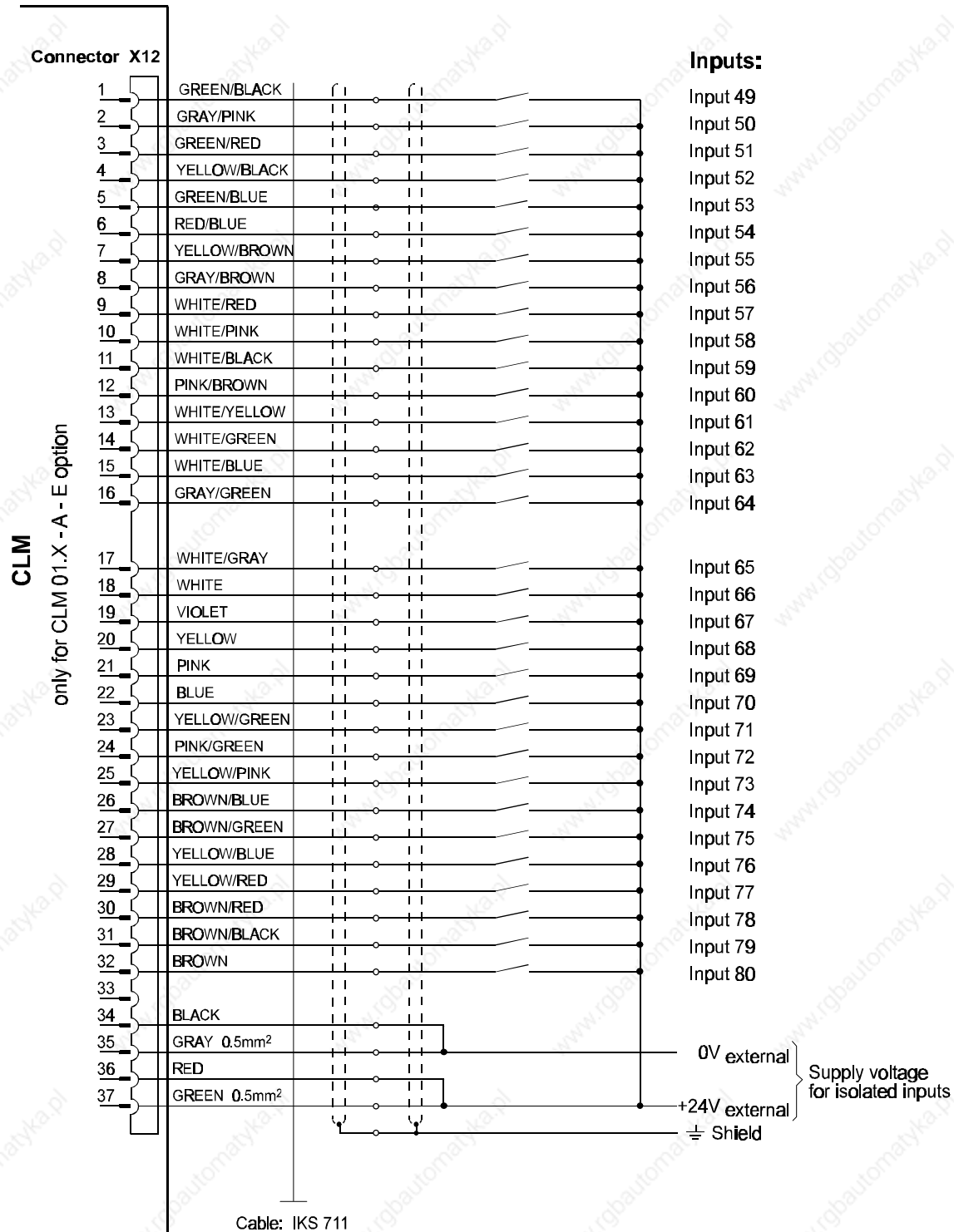
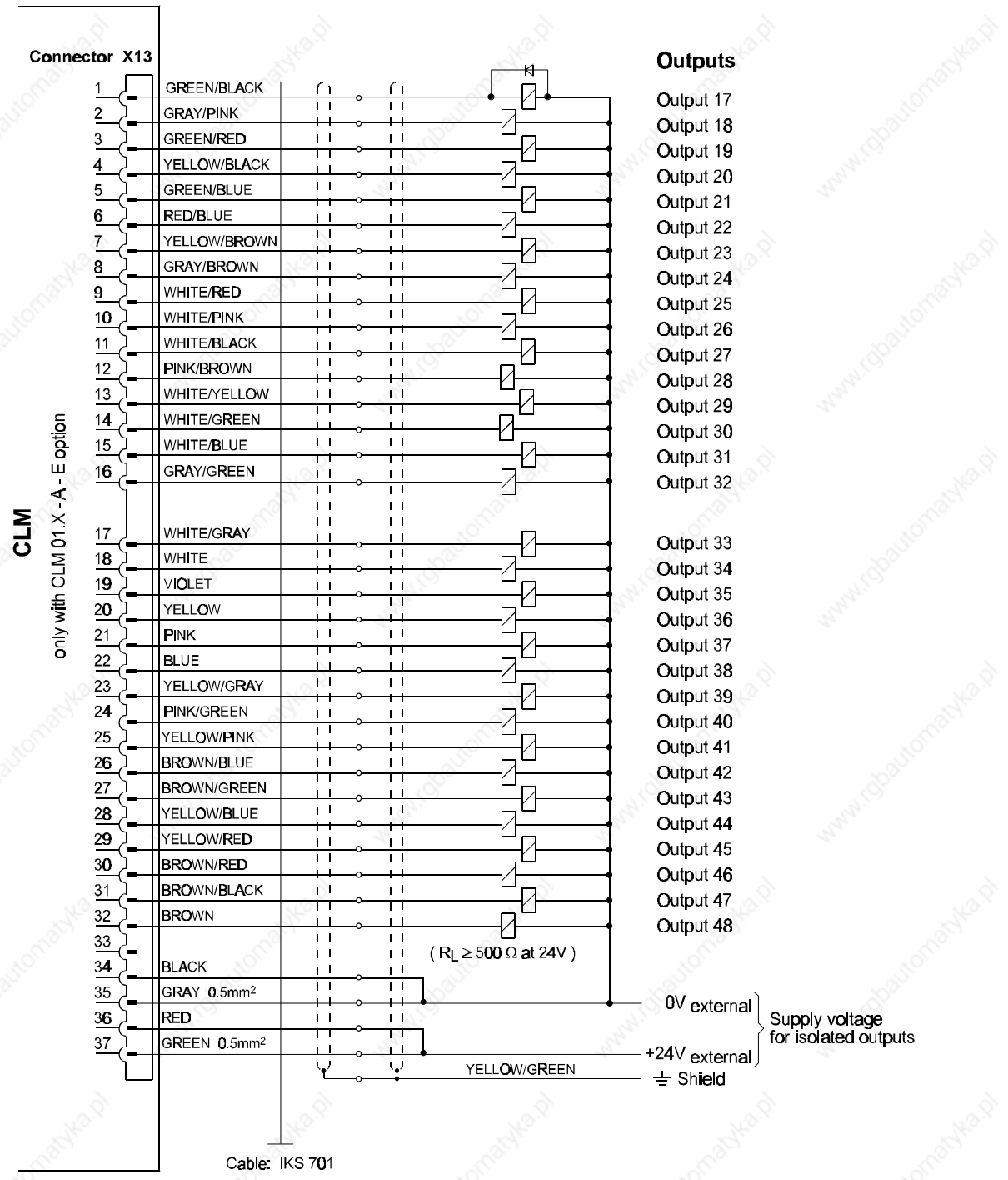

Fig. 9.11. Inp. CLM

Figure F-10 Inputs 49-80 (expanded)

F.11 Output Connections



All relays must have protective diodes!

Fig. 9.12. Outp. CLM

Figure F-11 Outputs 17-48 (expanded)

F.12 Command Value / Drive Enable and I/O Connections

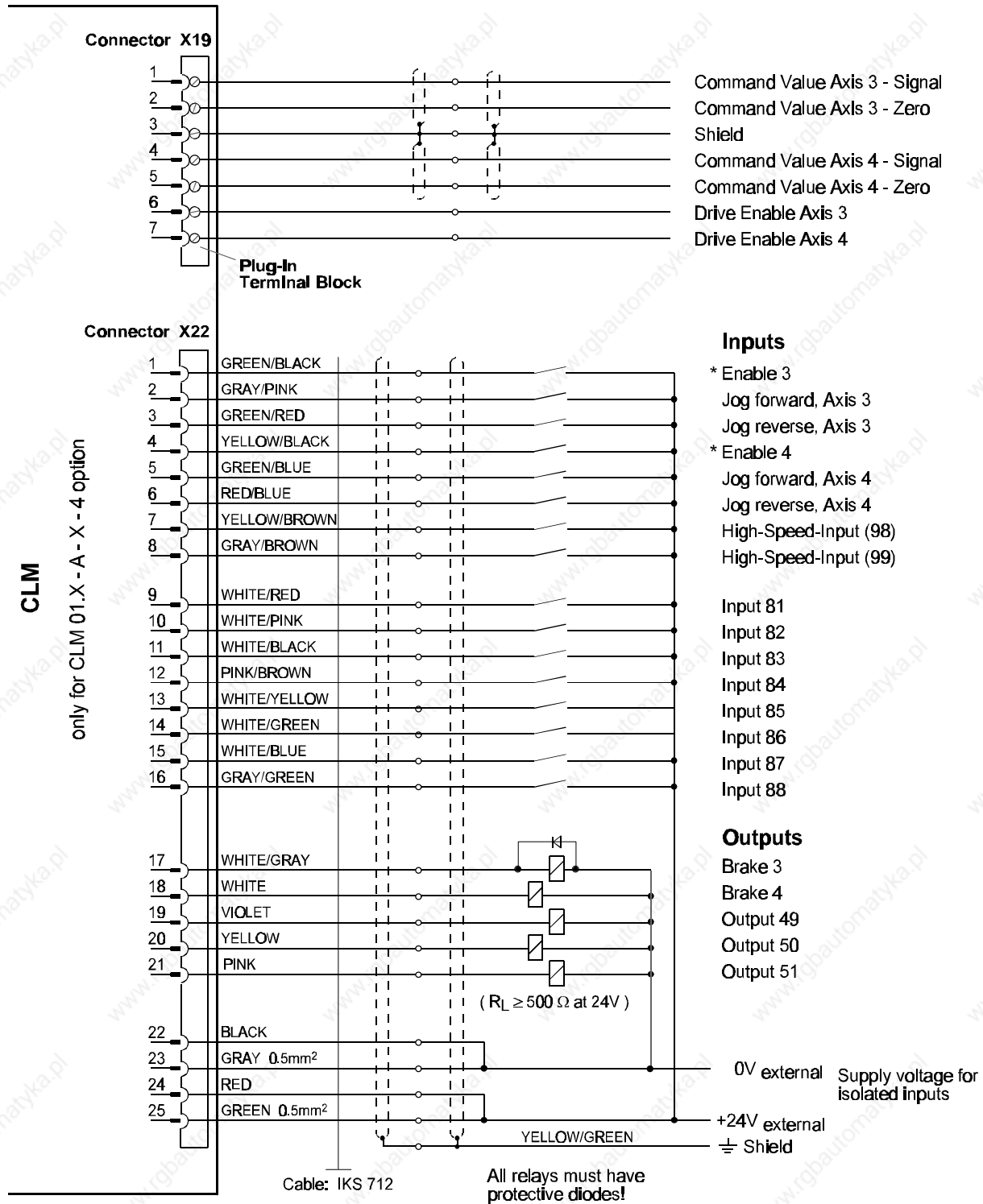

* = the necessary signals must be constant (no intermittent signals)!

Fig. 9.13. I/O CLM

Figure F-12 Command Value for Axes 3 and 4, Inputs/Outputs for Axes 3 and 4

F.13 Encoder Inputs, Axis 3

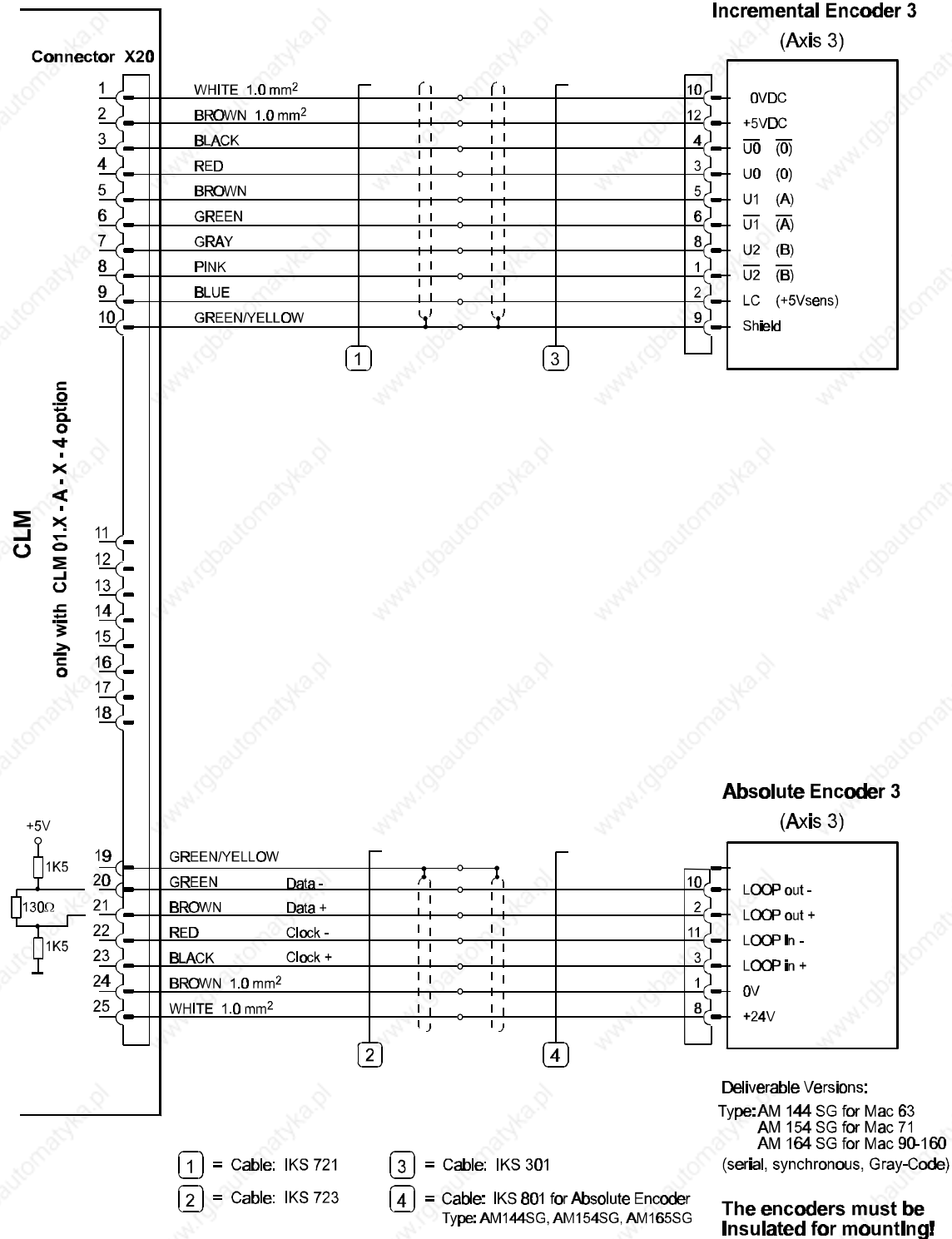

Fig. 9.14. Enc. A3 CLM

Figure F-13 Encoder, Axis 3 (Incremental Encoder, Absolute Encoder)

F.14 Encoder Inputs, Axis 4

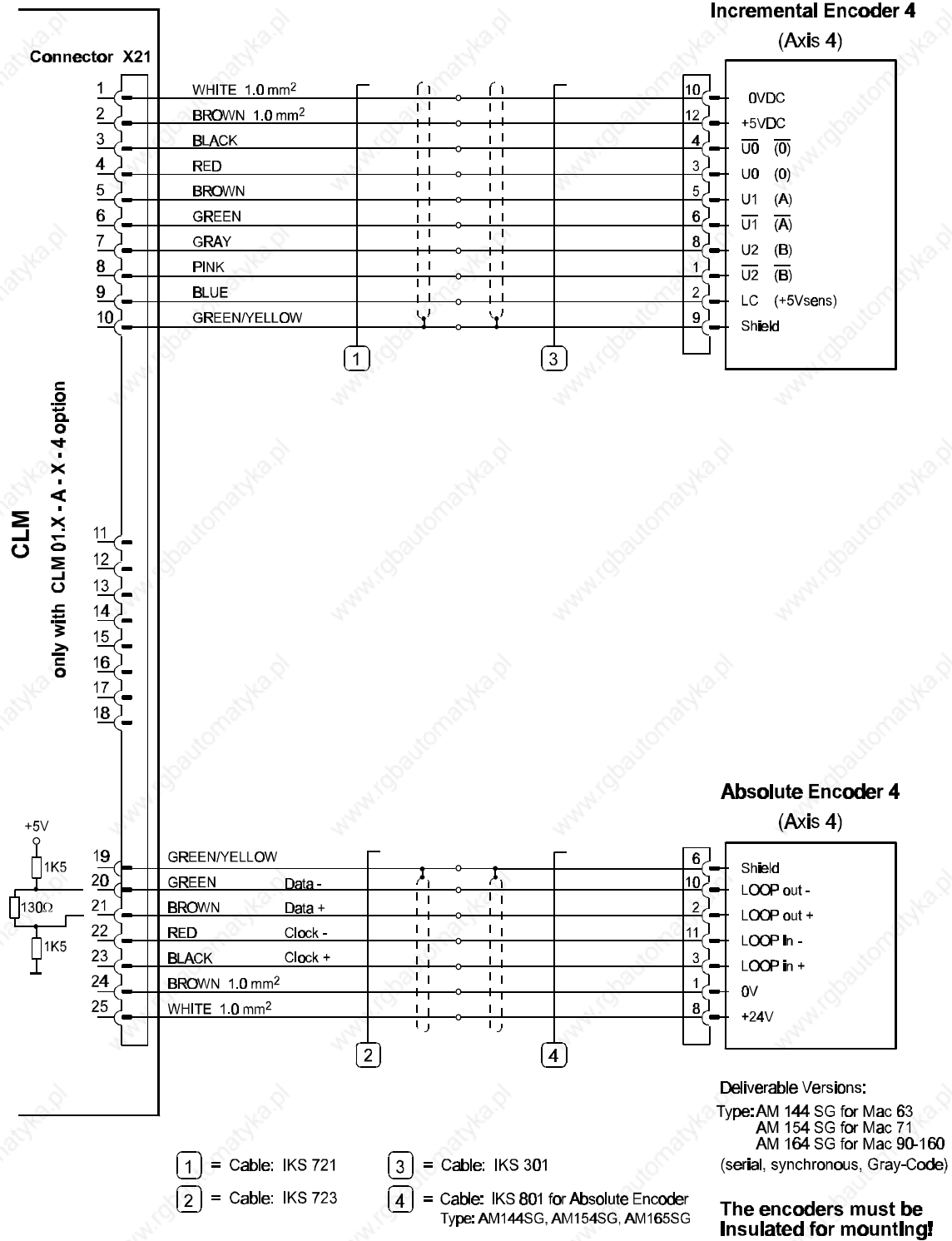

Fig. 9.15. Enc. AM CLM

Figure F-14 Encoder, Axis 4 (Incremental Encoder, Absolute Encoder)

F.15 CLM-TVM / TDM 1.2 & 2.1

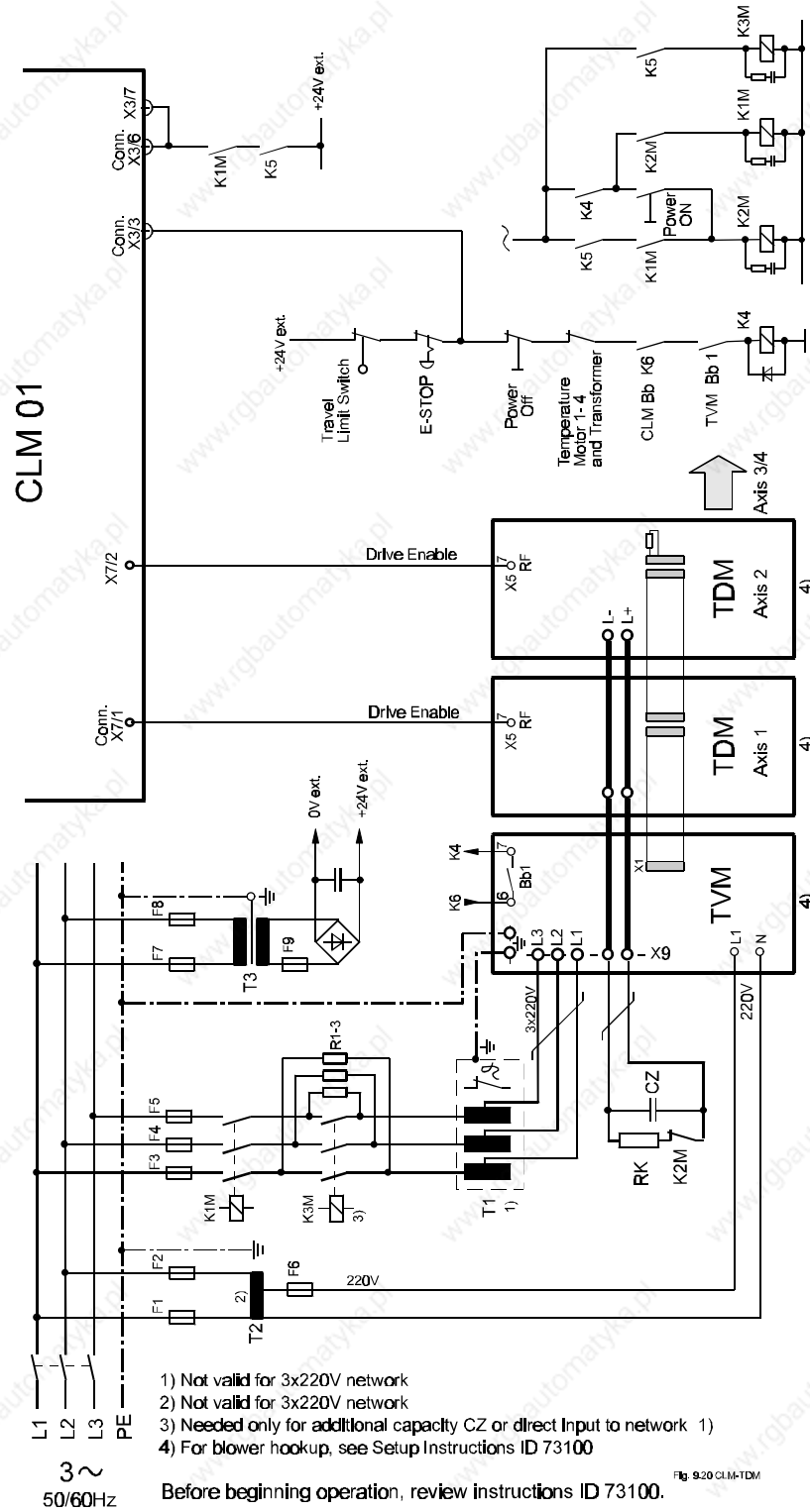

Figure F-15 CLM-TDM

F.16 CLM-TVM / TDM 1.2 & 2.1

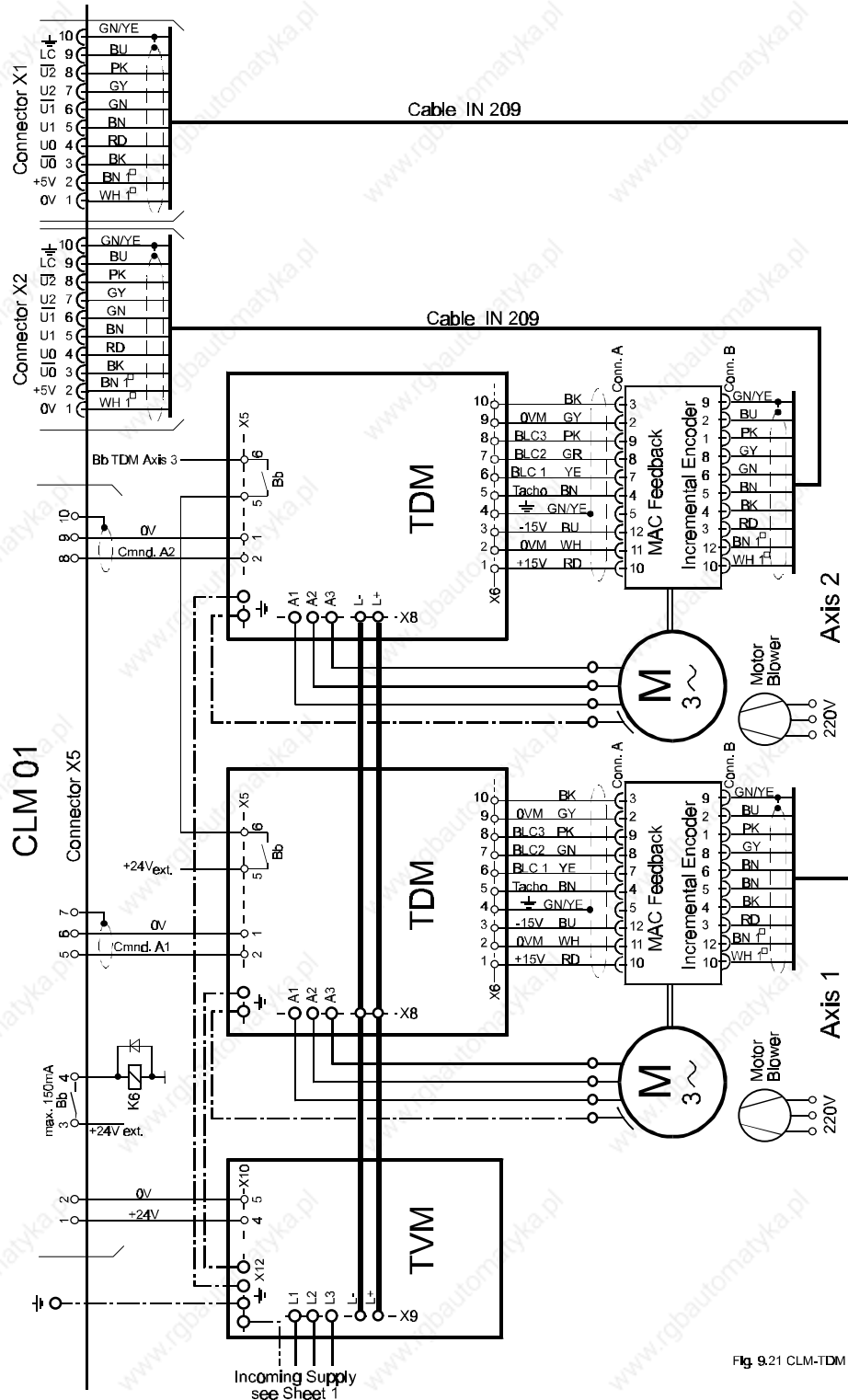

Fig. 9.21 CLM-TDM

Figure F-16 CLM-TDM

F.17 CLM-TVM / TDM 1.2 & 2.1

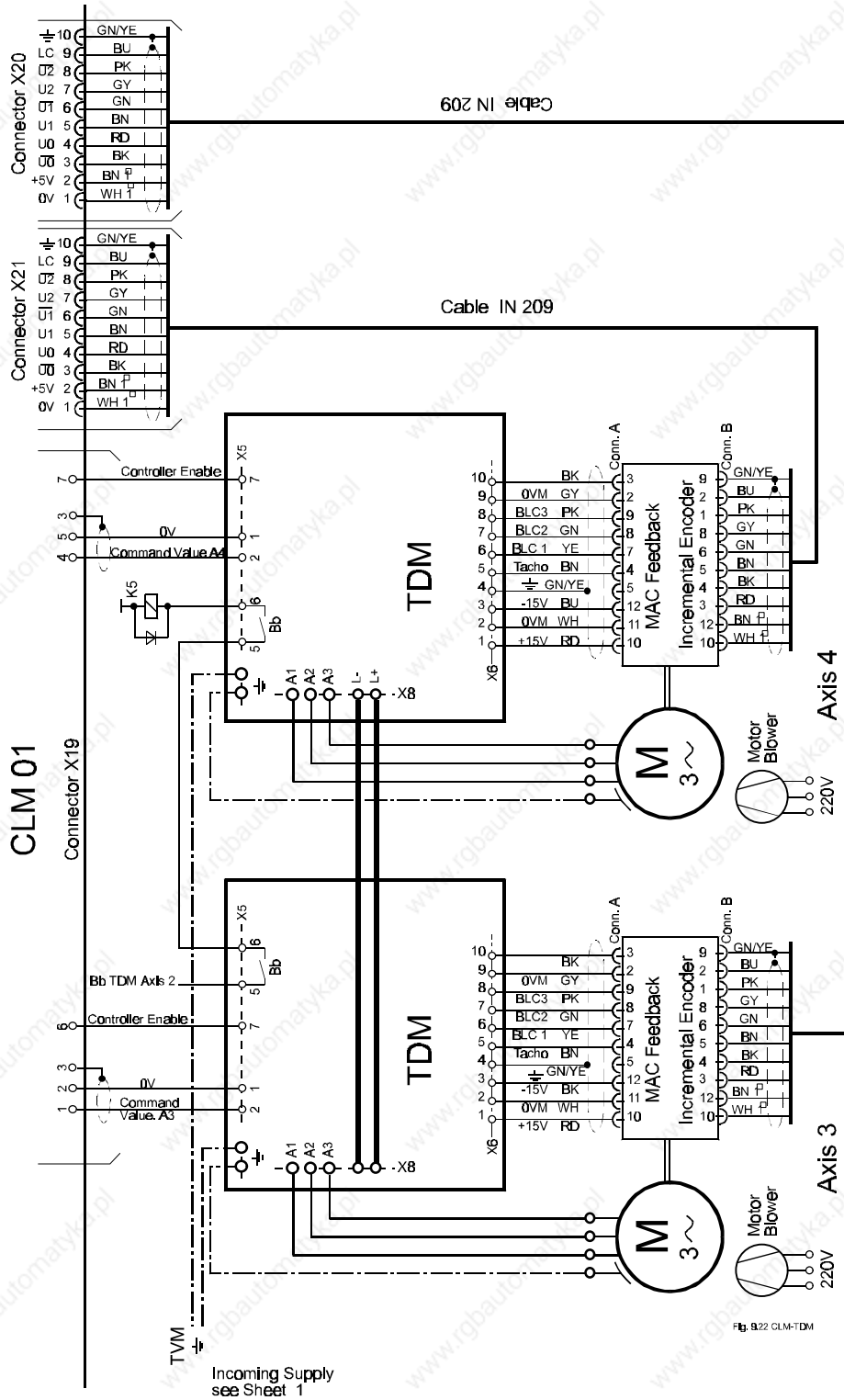

Figure F-17 CLM-TDM

F.18 CLM-TVM / TDM 3.2

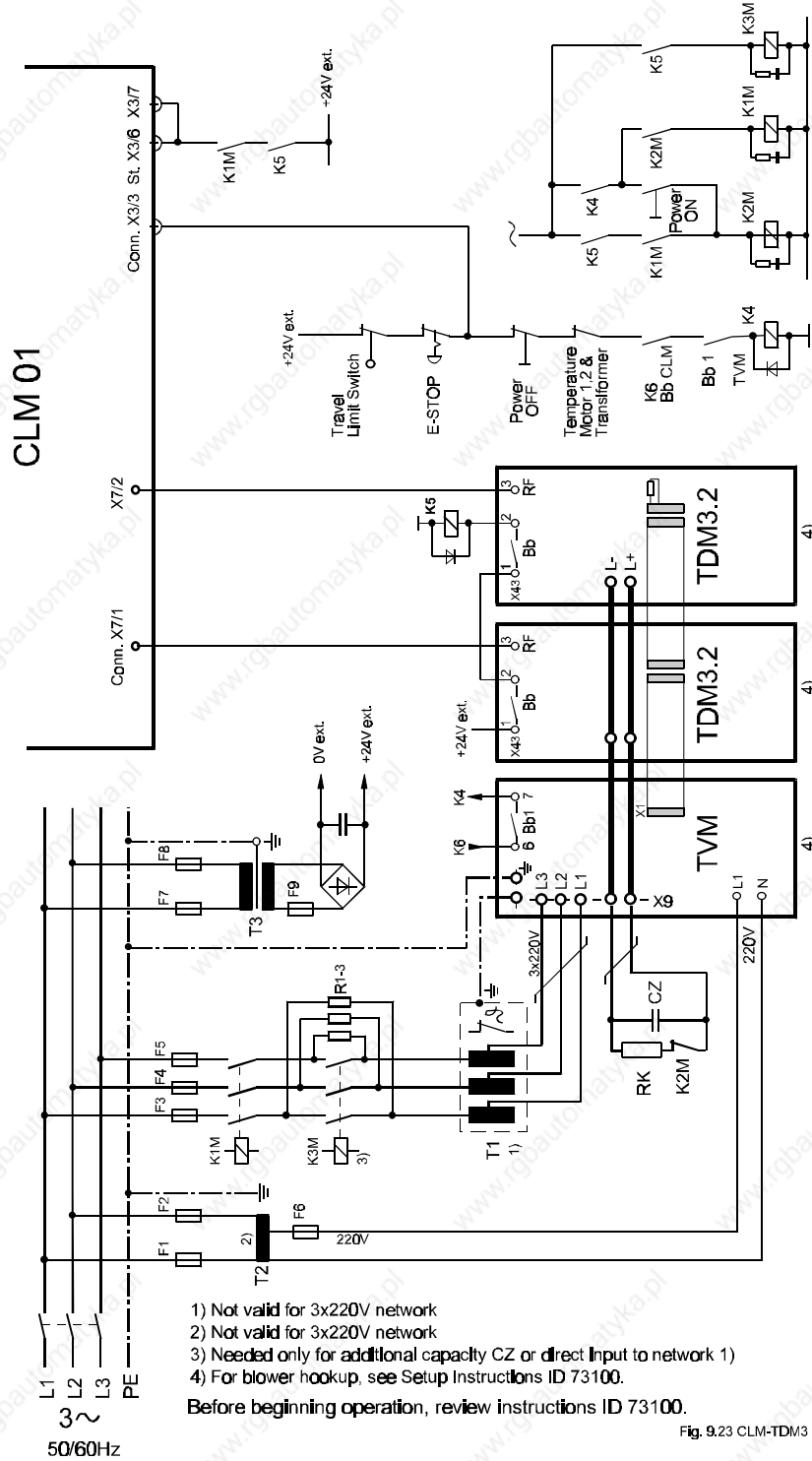

Figure F-18 CLM-TDM3

F.19 CLM-TVM / TDM 3.2

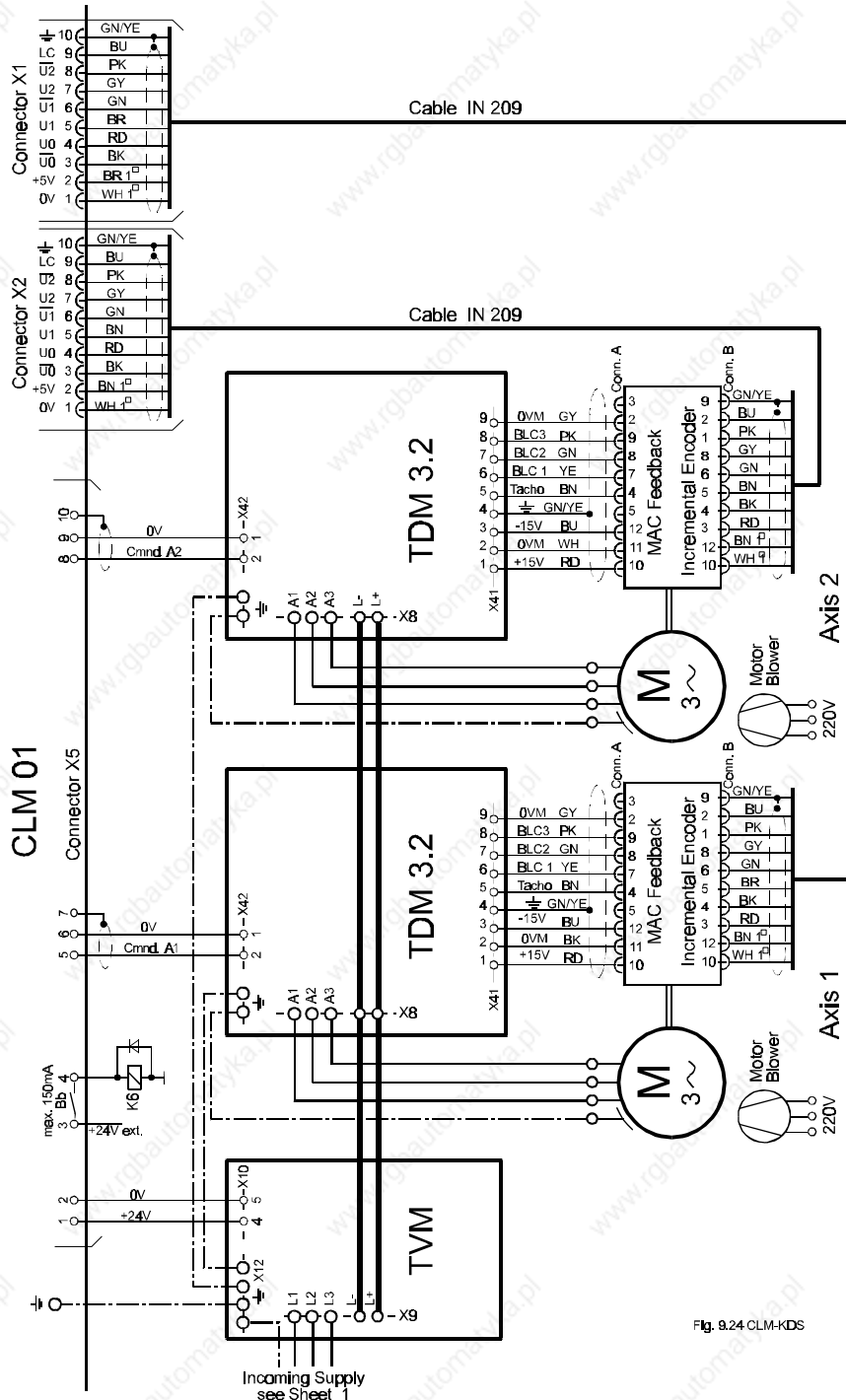

Fig. 9.24-CLM-KDS

Figure F-19 CLM-TDM3

F.21 CLM-KDV / KDS

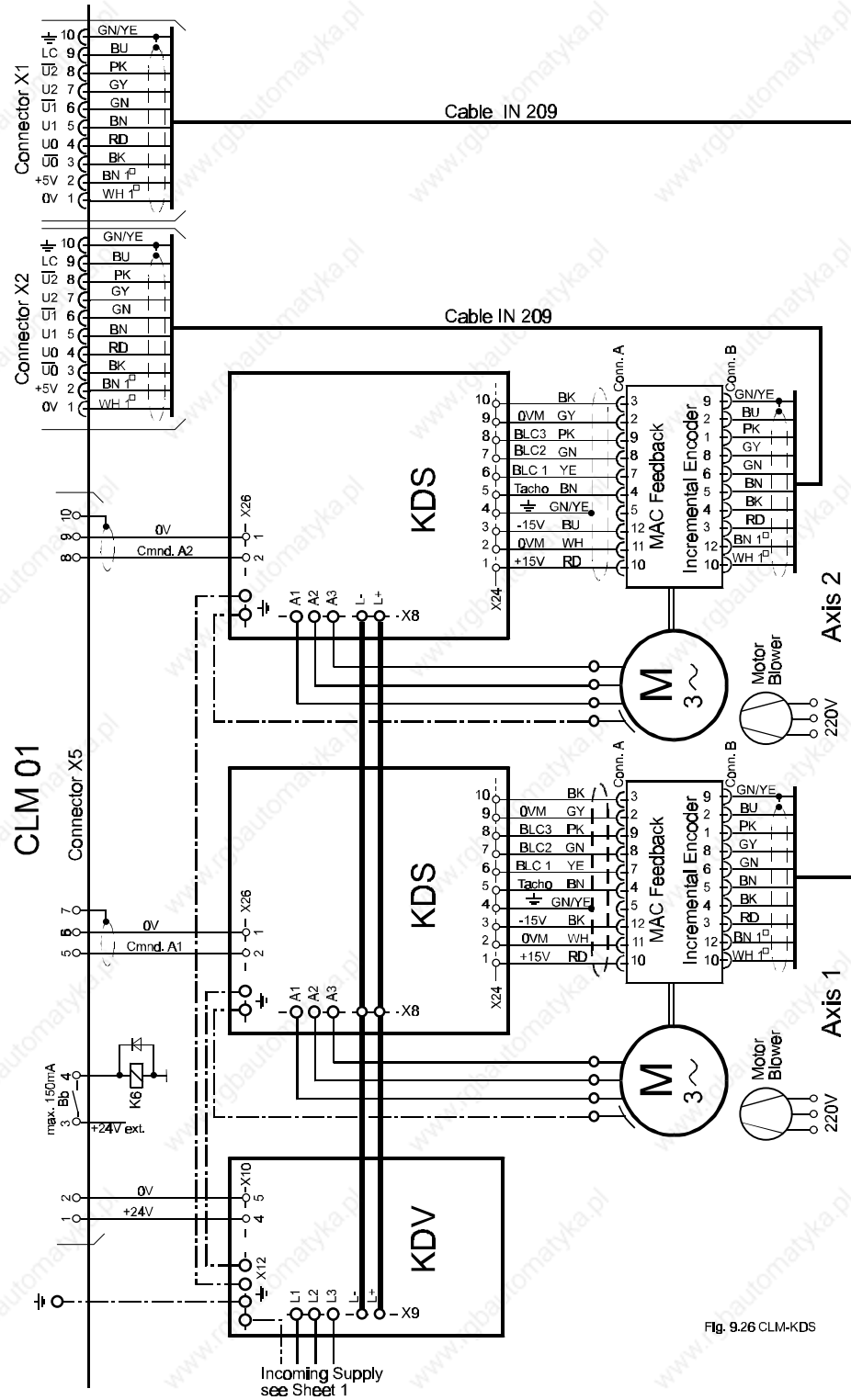
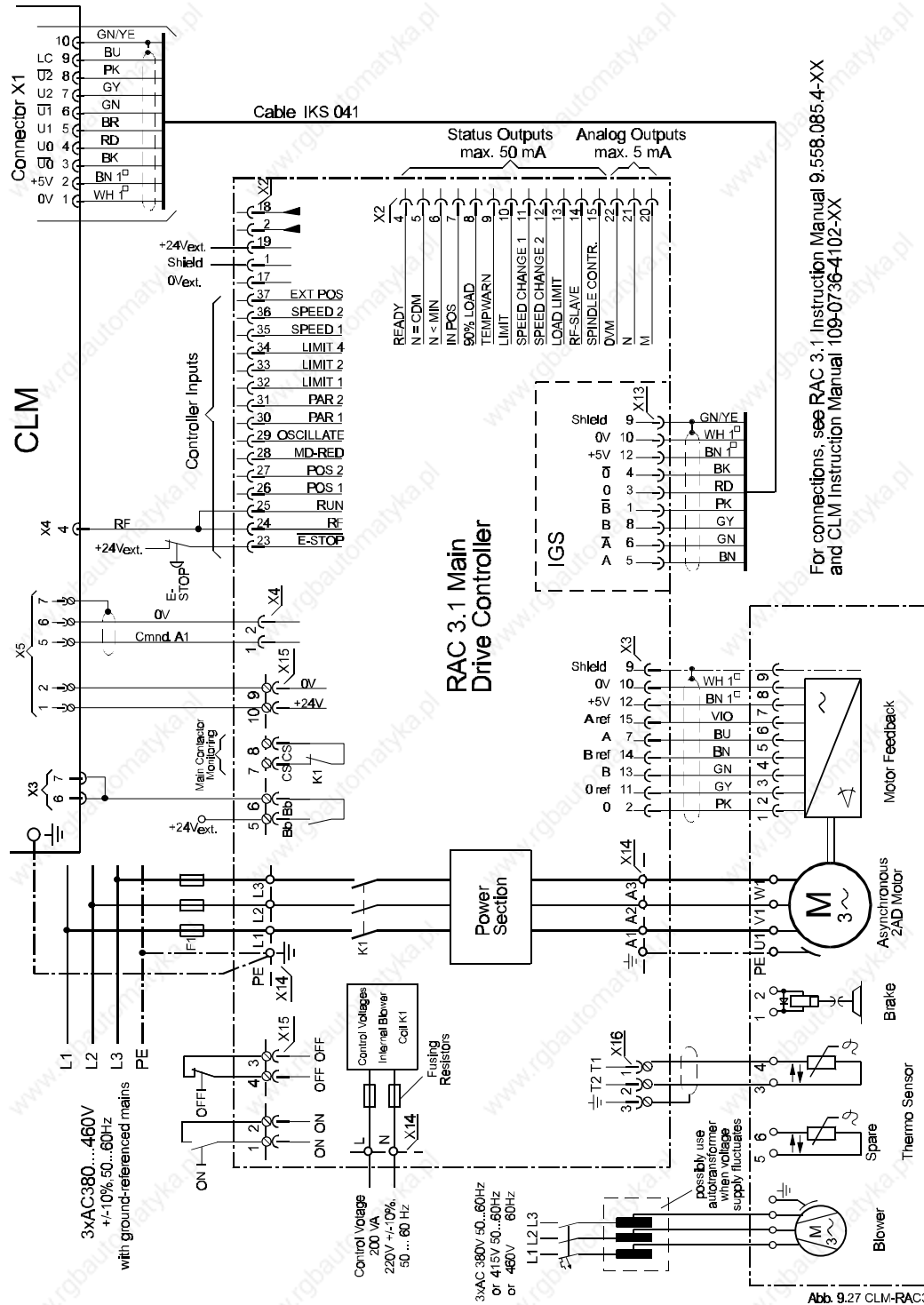

Fig. 9.26 CLM-KDS

Figure F-21 CLM-KDS

F.22 CLM-RAC 3.1



For connections, see RAC 3.1 Instruction Manual 9.558.085.4-XX and CLM Instruction Manual 109-0736-4102-XX

Abb. 9.27 CLM-RAC3

Figure F-22 CLM-RAC3

F.23 CLM-RAC 2.2



Abb. 9.28 CLM-RAC2

Figure F-23 CLM-RAC2

F.26 CLM-NAM / TVD / DDS (Absolute)

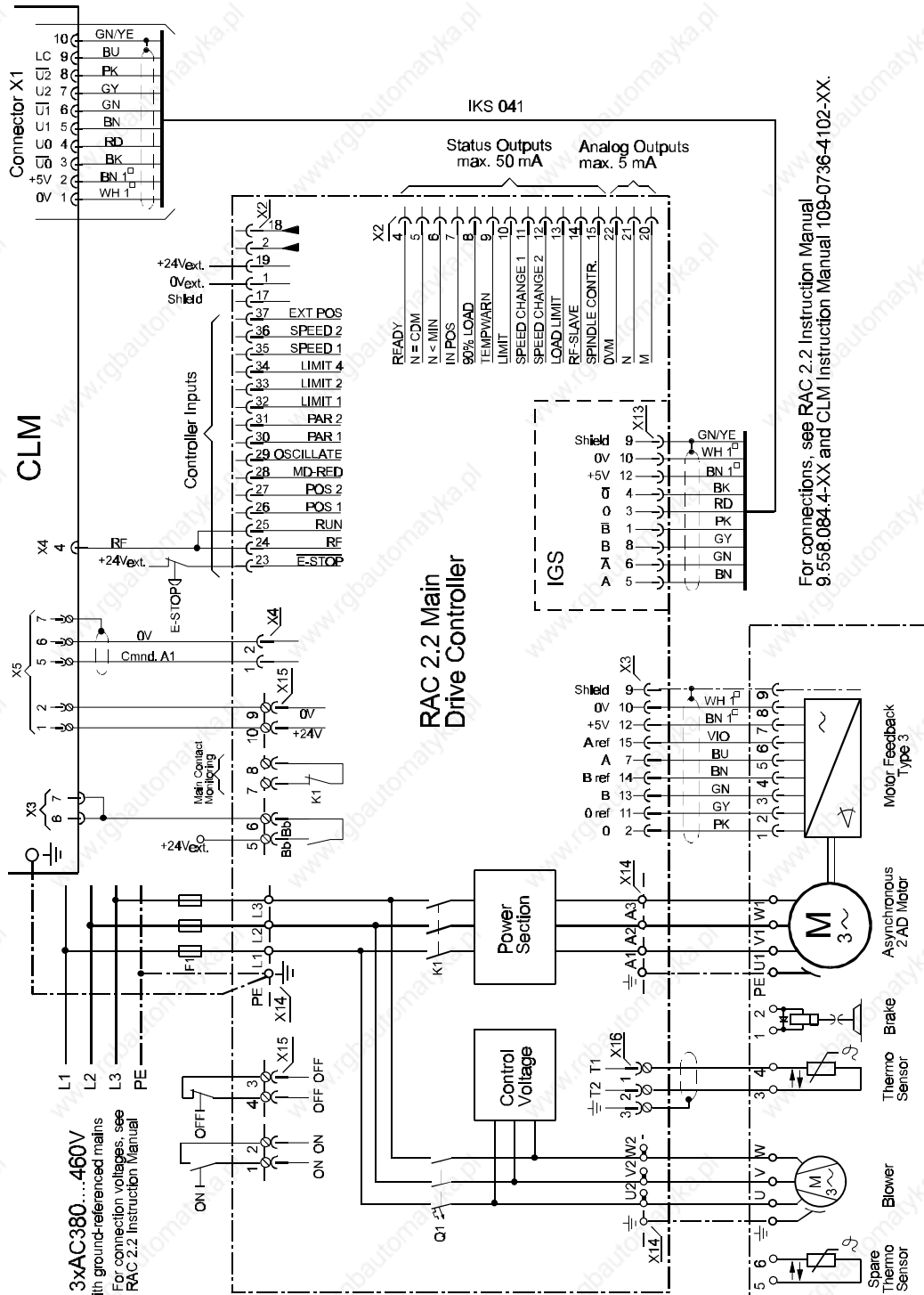
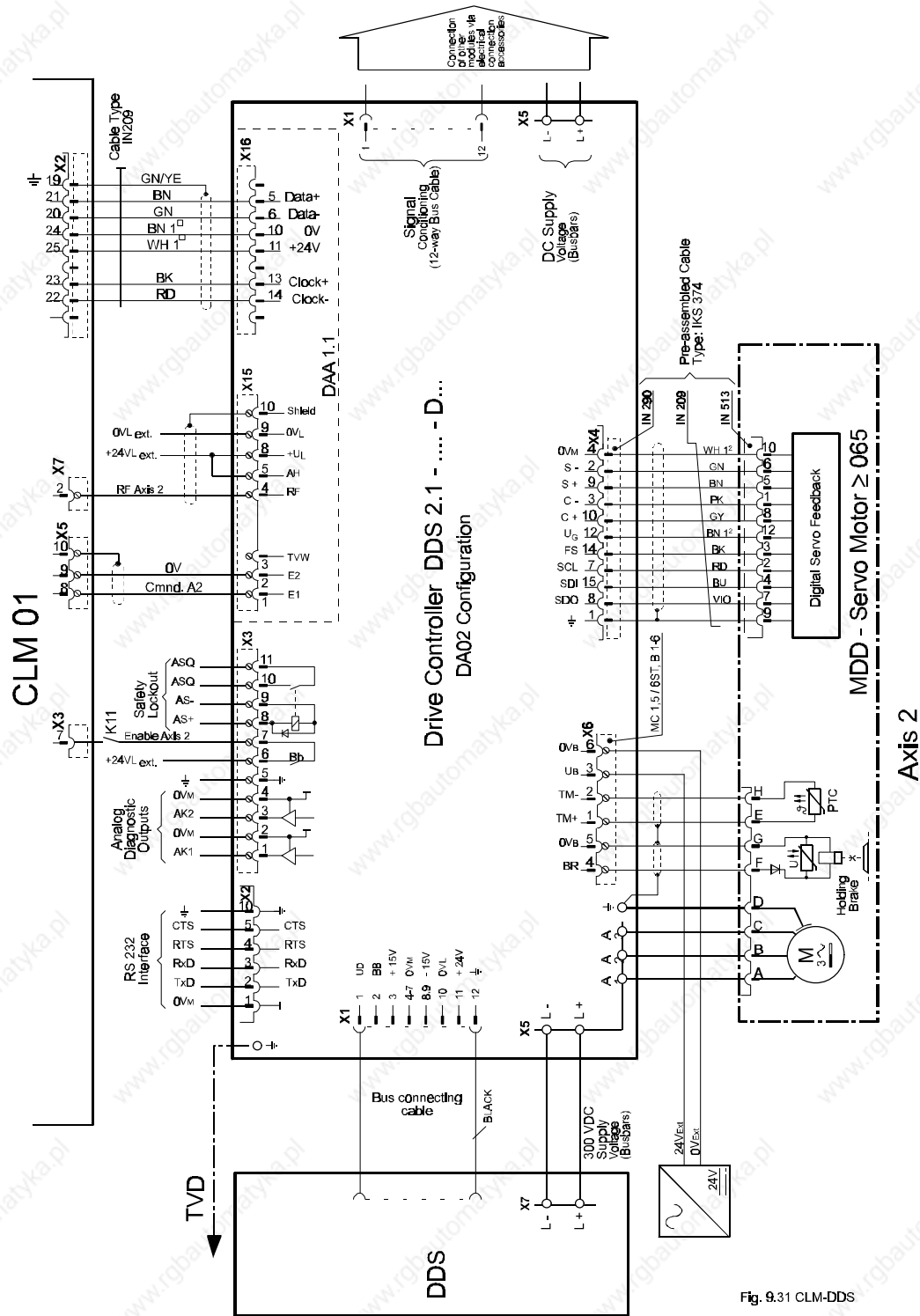

Fig. 9.31 CLM-DDS

Figure F-26 CLM-DDS

F.27 CLM-DKS / DAE (Incremental)

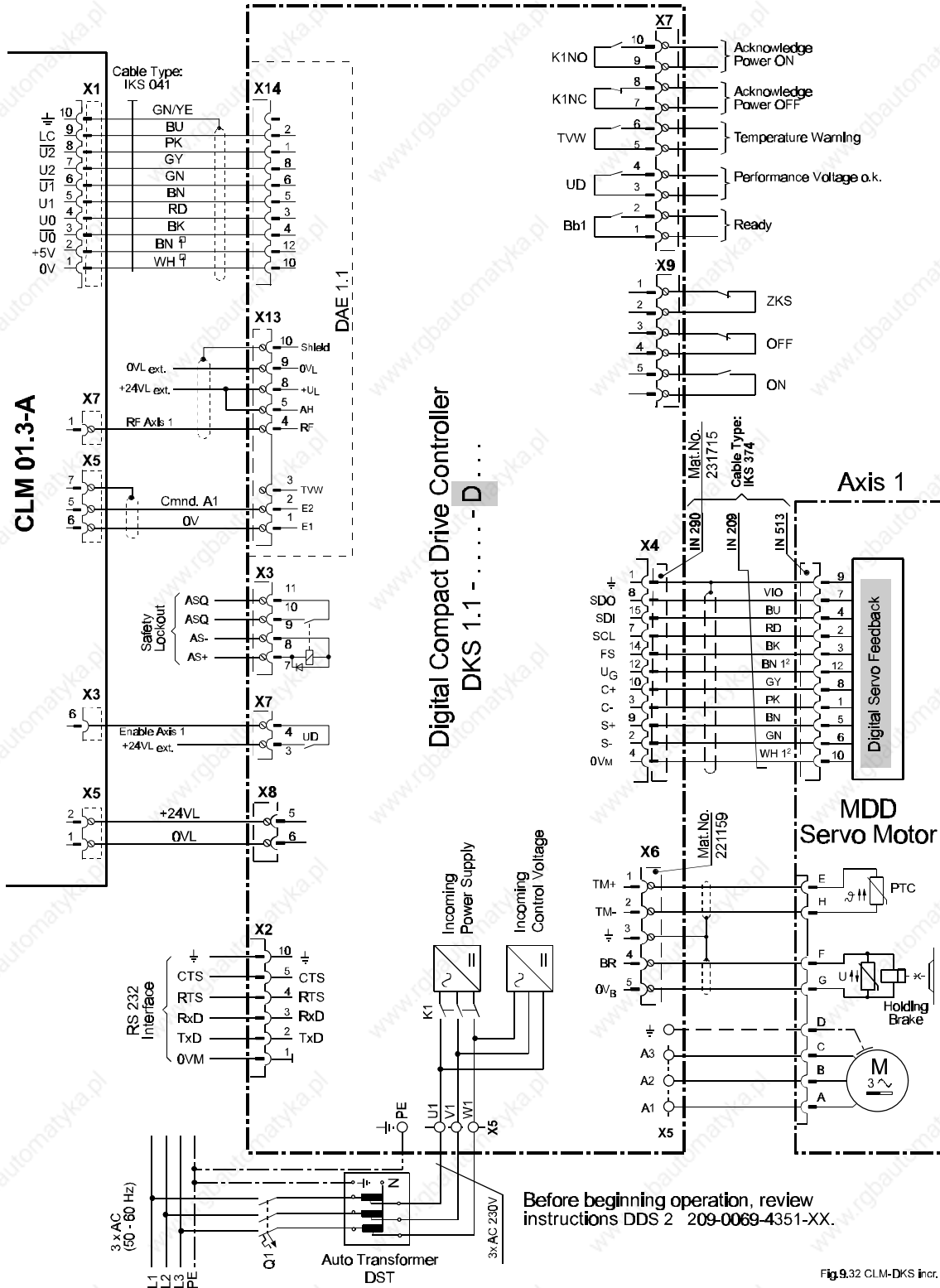

Fig.9.32 CLM-DKS incr.

Figure F-27 CLM-DKS / DAE

F.28 CLM-DKA / DAA (Absolute)

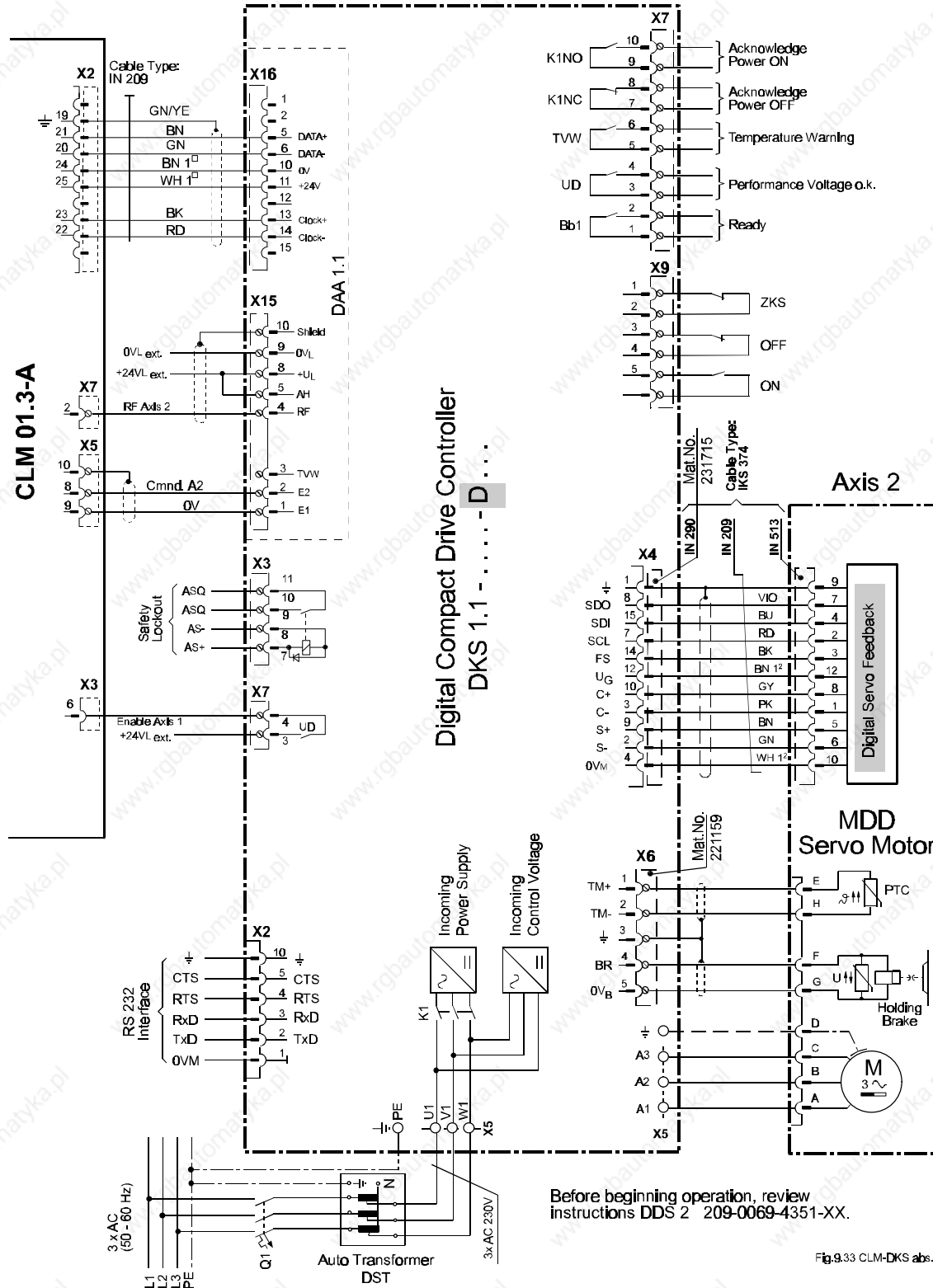

Fig.9.33 CLM-DKS abs.

Figure F-28 CLM-DKS / DAA

F.29 CLM-DKC (Incremental)

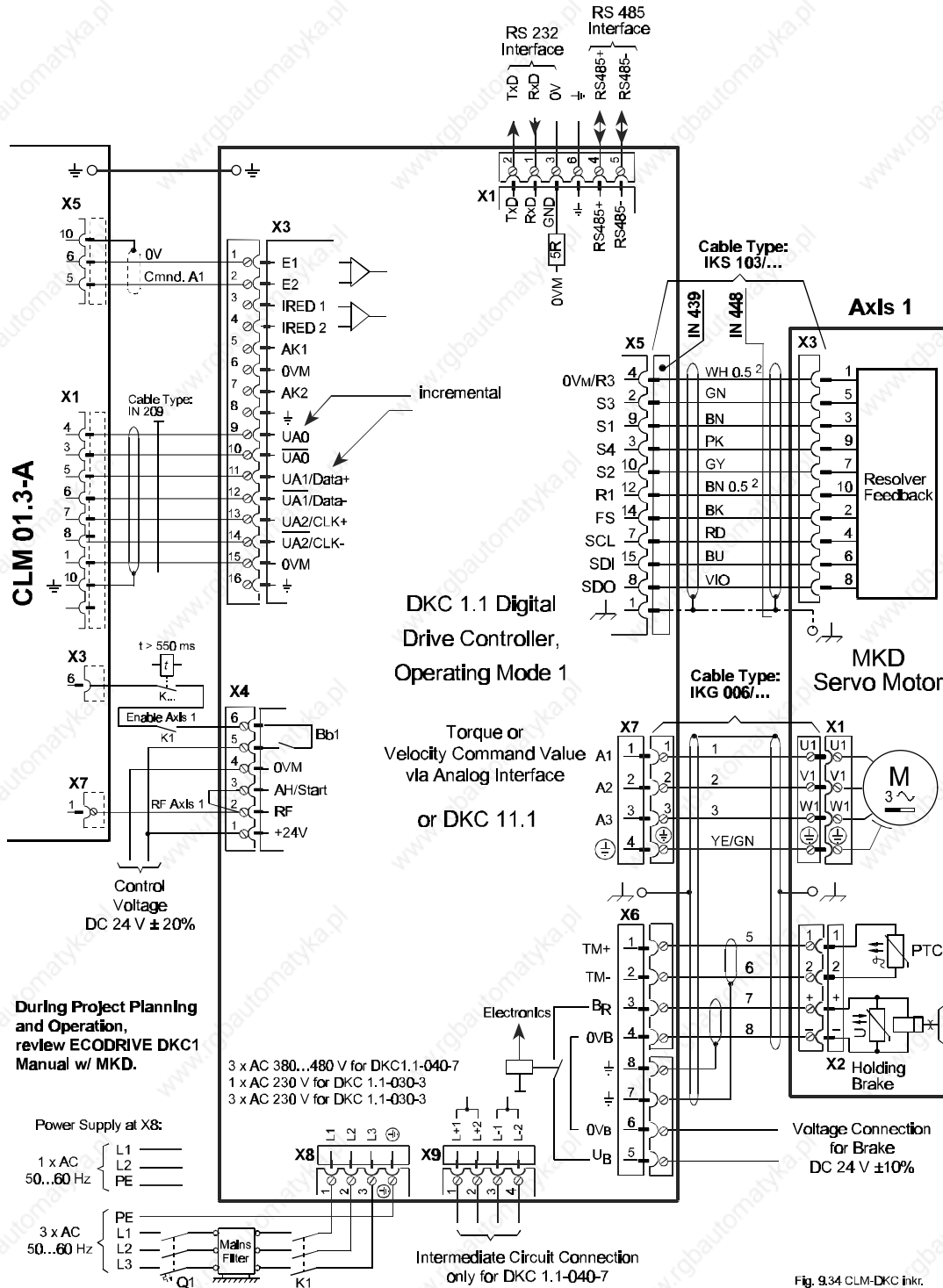

Fig. 9.34 CLM-DKC incr.

Figure F-29 CLM-DKC (Incremental)

F.30 CLM-DKC (Absolute)

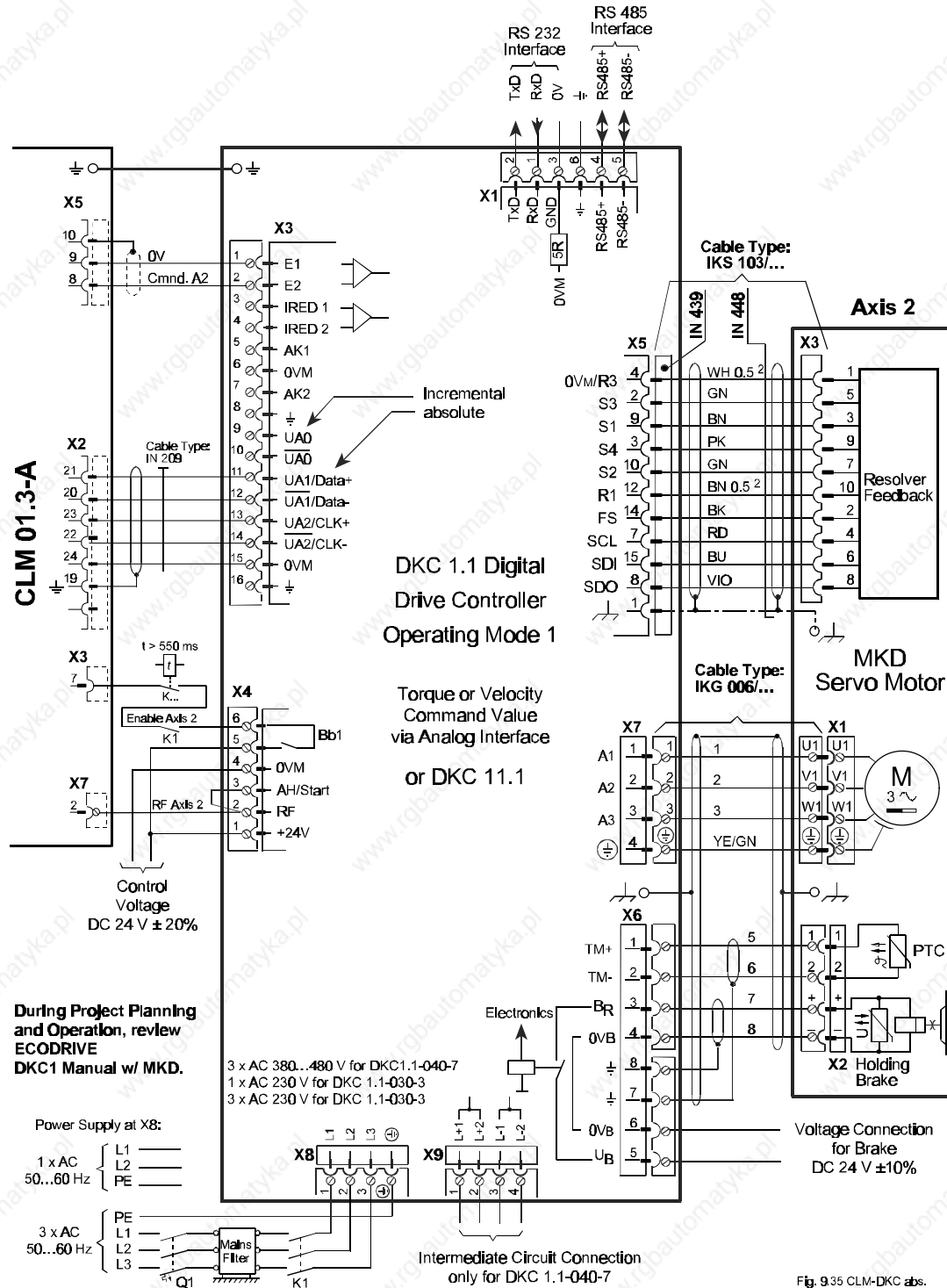

Fig. 9.35 CLM-DKC abs.

Figure F-30 CLM-DKC (Absolute)

G. INSTALLATION DRAWINGS

CAUTION: The drawings in this Appendix are included for illustrative purposes only and are subject to change without notice. Check with Indramat to be sure you are working with the latest drawings prior to installing, wiring and powering equipment.

G.1 Keypad Replacement Face Plate Panel Dimensions (AM 1037)

(Refer to this drawing when keypad is to be remote-mounted.)

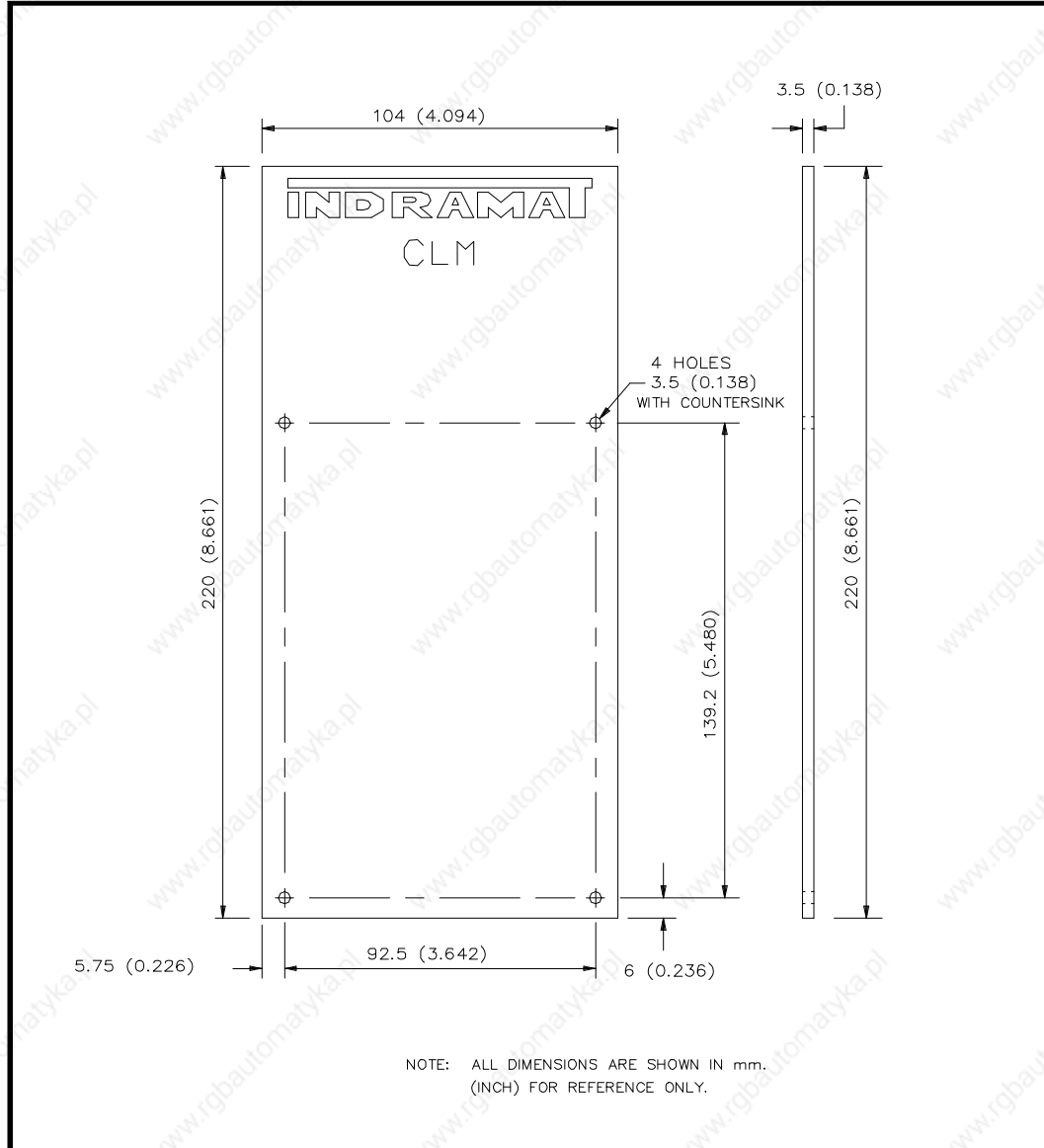

NOTE: ALL DIMENSIONS ARE SHOWN IN mm.
(INCH) FOR REFERENCE ONLY.

REXROTH INDRAMAT HOFFMAN ESTATES, IL.		CLM KEYPAD REPLACEMENT PANEL					QUALITY DRIVES INDRAMAT				
		DRAWING NUMBER AM-1037									
INFO.	NAME	DATE	REV.	DESCRIPTION	DATE	NAME	E.C.O. NUMBER	PART NUMBER	SCALE	N.T.S.	SHEET 1 OF 1
DRAWN BY	D. PADILLA	7/17/89									REVISION FOR
CHECKED BY											REVISED BY
ENGINEER APPROVAL											
<small>REPRINTS PROHIBITED. THIS DOCUMENT FOR CUSTOMER USE ONLY. NOT TO BE COPIED OR RELEASED. REFERENCE COPYRIGHT LAW</small>											

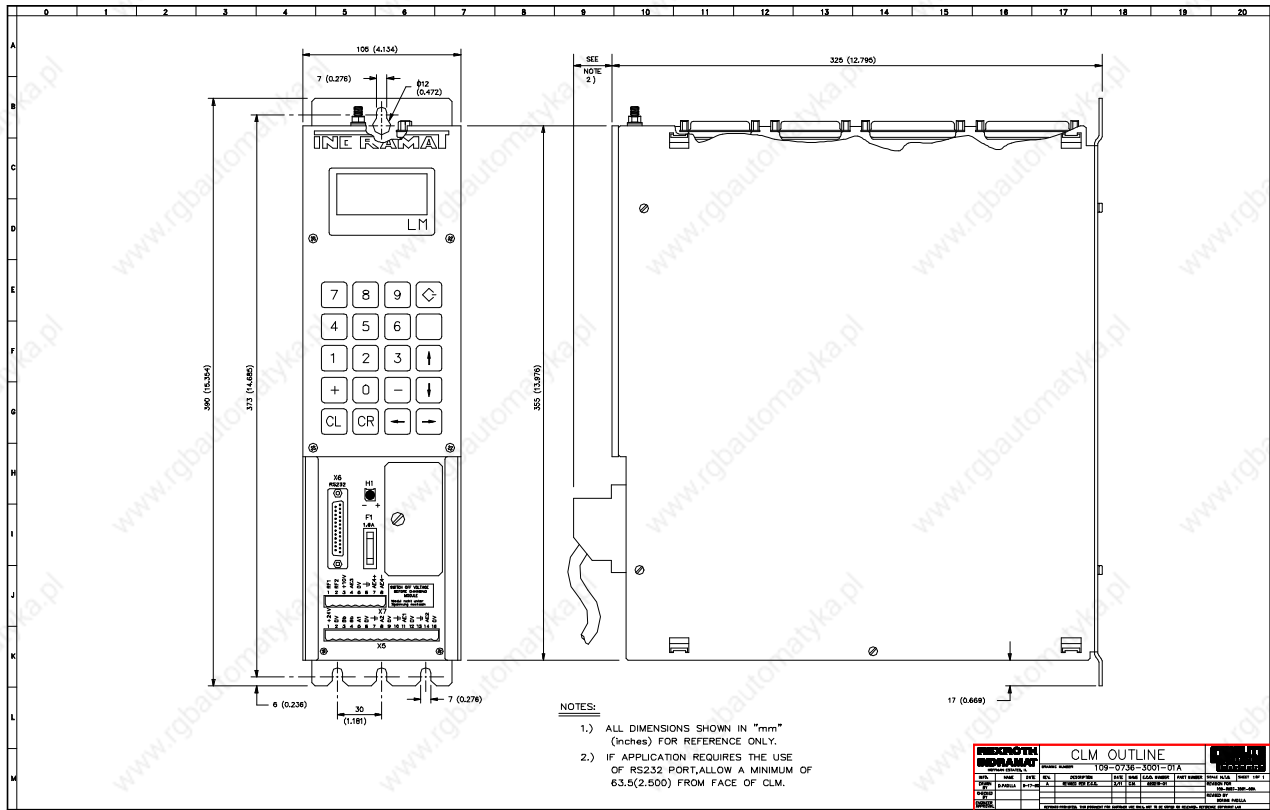
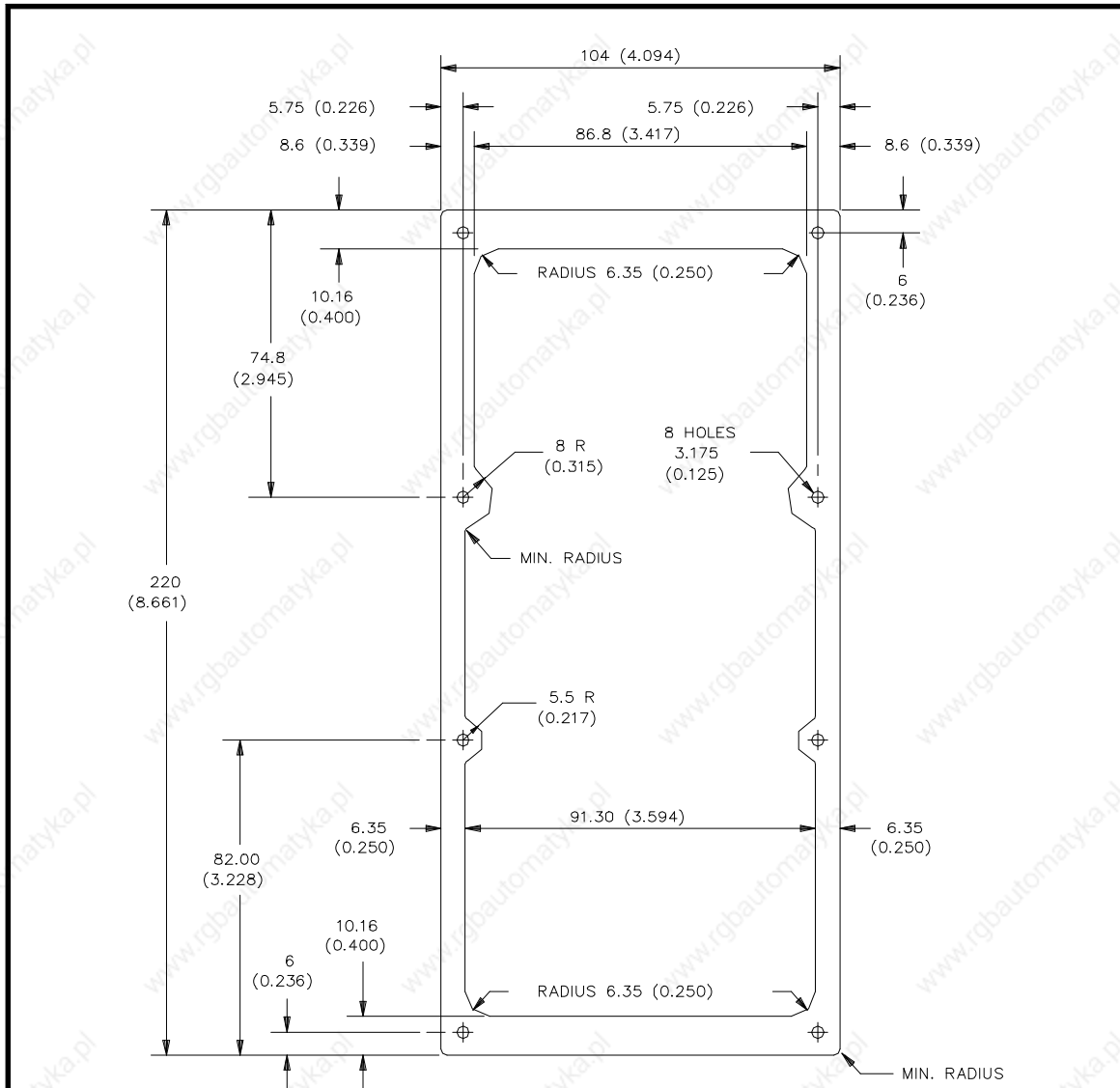

Figure G-1 CLM Outline/Mounting Dimensions (109-0736-3001-01A)



- NOTES:
- 1.) ALL DIMENSIONS ARE SHOWN IN mm, (INCH) FOR REFERENCE ONLY.
 - 2.) GASKET THICKNESS = 3/16"
 - 3.) GASKET MATERIAL = CLOSED CELL NEOPRENE BLEND FOAM
 - 4.) BOTH SIDES OF GASKET HAVE APPLICATION OF PRESSURE SENSITIVE ADHESIVE

REXROTH INDRAMAT HOFFMAN ESTATES, IL.		CLM/CTA KEYPAD REMOTE INSTALLATION GASKET						QUALITY DRIVES INDRAMAT		
		DRAWING NUMBER AM-1035								
INFO.	NAME	DATE	REV.	DESCRIPTION	DATE	NAME	E.C.O. NUMBER	PART NUMBER	SCALE N.T.S.	SHEET 1 OF 1
DRAWN BY	D. PADILLA	6/16/89	A	CORRECTED NOTES 2 & 3, ADDED 4	07/17/89	D.P.			REVISION FOR	
CHECKED BY			B	MODIFIED GASKET FOR BOTH CLM'S	06/04/91	D.P.			REVISED BY	
ENGINEER APPROVAL			C	REVISED PER E.C.O.	03/18/93	C.M.	940218-03			
REPRINTS PROHIBITED. THIS DOCUMENT FOR CUSTOMER USE ONLY, NOT TO BE COPIED OR RELEASED. REFERENCE COPYRIGHT LAW										

Figure G-2 CLM Keypad Remote Installation Gasket (AM 1035)

H. CLM TYPE CODE DESCRIPTIONS

H.1 CLM Hardware Type Code Description

Hardware Type Code Designation:

CLM - XX.X - X - X - X - X

Indramat Position Control Designation _____

CLM Hardware Version Number _____

- 1.0 (and 1.1) Original Version
- 1.2 Two Line Display
- *01.2 AK11 Memory Module,
additional drive connectors
- 01.3 Four Line Display

Corresponding Software Type _____

- A = Standard Two Axis
- M = Flying Cutoff
- R = Feed to Length (Single Axis CFS emulation)
- S = Sidecut Extrusion Cutoff
- Z = Rollfeed Dual Axis Feed to Length

Hardware Options _____

- 0 = No Option
- E = Expansion I/O Board

Number of Axes _____

- 1 = 1 Axis Flying Shear and Standard I/O
- 2 = 2 Axis
- 4 = 4 Axis

Display _____

- 0 = Standard LCD Display
- 1 = Backlit LCD Display

* Many 01.2 units were shipped with 4-line display.
(The lower two lines were not used.)

H.3 IDS Hardware Type Code Description

Hardware Type Code Designation: IDS - X . X - X

Product Type _____

Ids Hardware Version Number _____

IDS Hardware Revision Number _____

Number of Digits to the Right of _____
the Decimal Point (0 to 3)
(These decade switches will be in Red as opposed to Black.)

H.4 IDS Software Type Code Description

Software Type Code Designation: IDS - X . X - X

Product Type _____

IDS Software Version Number _____

IDS Software Revision Number _____

Corresponding CLM Software Version (Letter) _____
Required For The IDS Software To Work

H.5 SOT Hardware Type Codes

Hardware Type Code Designation:	<u>SOT</u>	<u>XX</u>	<u>X</u>	<u>X</u>	<u>X</u>	<u>-</u>	<u>XX</u>
Model Name: SOT Station Operator Terminal _____							
Hardware Version _____ 01= 8 line display 02= 16 line display							
Construction _____ E = Station Unit A = Portable (not yet available)							
RAM Capacity _____ 1 = 128 KB 2 = 512 KB							
Keyboard _____ A = Standard R = Rollfeed							
CLM Application _____ CA = Standard CR = Rollfeed CU = Standard (Programmable with ScreenManager™) CZ = Infeed/Outfeed							

H.6 SOT Software Type Codes

Software Type Code Designation:

	<u>S</u>	<u>C</u>	<u>2.00</u>	-	<u>XX.02.X</u>	<u>X</u>
Model Name: SOT Station Operator Terminal						
Control Type _____						
M = MT-CNC						
C = CLM						
Hardware Version Number _____						
Revision Number _____						
Software Version _____						
CR = Rollfeed						
CU = Standard (Programmable with ScreenManager)						
CZ = Infeed/Outfeed						
Software Revision _____						
Revision Supported with Documentation _____						
Minor Revision (Not Supported with Documentation) _____						

READER COMMENT CARD AND REGISTRATION FORM

We welcome your evaluation of this manual. Please complete this form to help us to improve our publications and also to receive notification of revisions to this manual.

Publication: **CLM 01.3-A Four-Axis Positioning Control**
Type of Manual: **User's Manual**
Publication No. 74794
Part No. 279795
Revision: **C, 05/98**

Please indicate the degree to which each statement applies to you by circling whether you
① strongly agree, ② agree, ③ are uncertain, ④ disagree, or ⑤ strongly disagree with the statement.

- | | |
|--|-----------|
| 1. The manual is well organized. | ① ② ③ ④ ⑤ |
| 2. I can find the information I want. | ① ② ③ ④ ⑤ |
| 3. The index is thorough. | ① ② ③ ④ ⑤ |
| 4. The information is easy to understand. | ① ② ③ ④ ⑤ |
| 5. The manual is clearly written. | ① ② ③ ④ ⑤ |
| 6. Concepts and vocabulary are easy to understand. | ① ② ③ ④ ⑤ |
| 7. Examples are clear and helpful. | ① ② ③ ④ ⑤ |
| 8. The manual contains enough illustrations. | ① ② ③ ④ ⑤ |
| 9. Layout and format enhance the manual's usefulness. | ① ② ③ ④ ⑤ |
| 10. The quality of this manual would influence any repeat purchase decision. | ① ② ③ ④ ⑤ |
| 11. The scope of the information in the manual meets my needs. | ① ② ③ ④ ⑤ |

Name _____

Company _____

Address _____ **Dept** _____

City _____ **State** _____ **Zip** _____

Telephone (____) _____

Comments: _____

----- Tape Closed -----

From:

Technical Documentation Department
Rexroth Corporation/Indramat Division
5150 Prairie Stone Parkway
Hoffman Estates, Illinois 60192
U.S.A.

----- Tape Closed -----

