



Allen-Bradley

***160 SSC™
Variable Speed
Controller
(Series B)***

***0.37 – 2.2 kW (0.5 – 3 HP)
FRN 5.xx – 6.xx***

**User
Manual**

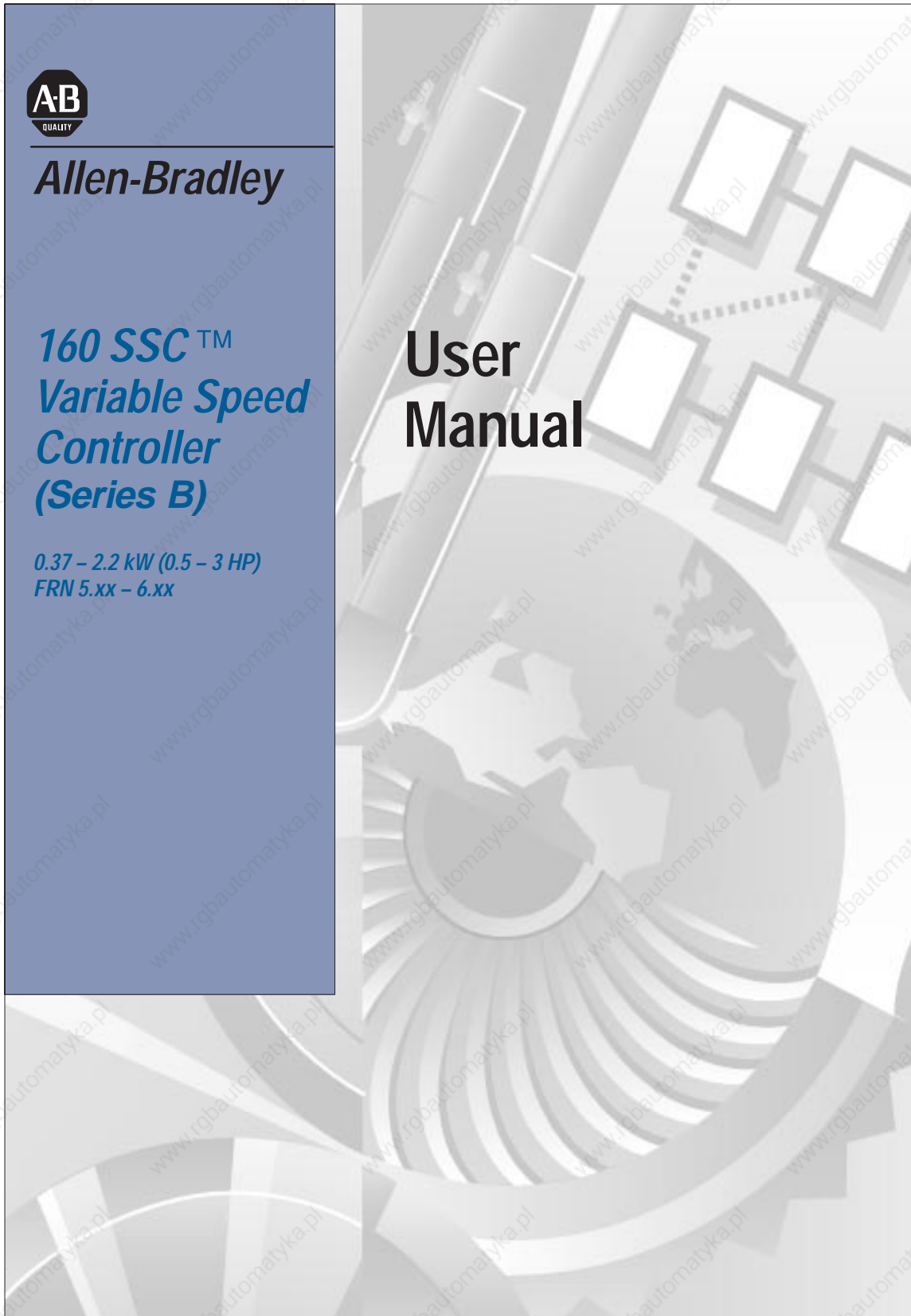

Important User Information

In no event will the Allen-Bradley Company be responsible or liable for indirect or consequential damages resulting from the use or application of this equipment.

The examples and diagrams in this manual are included solely for illustrative purposes. Because of the many variables and requirements associated with any particular installation, the Allen-Bradley Company cannot assume responsibility or liability for actual use based on the examples and diagrams.

No patent liability is assumed by Allen-Bradley Company with respect to use of information, circuits, equipment, or software described in this manual.

Reproduction of the contents of this manual, in whole or in part, without written permission of the Allen-Bradley Company is prohibited.

Throughout this manual we use notes to make you aware of safety considerations.

The information in this manual is organized in numbered chapters. Read each chapter in sequence and perform procedures when you are instructed to do so. Do not proceed to the next chapter until you have completed all procedures.

Throughout this manual we use notes to make you aware of safety considerations:



ATTENTION: Identifies information about practices or circumstances that can lead to personal injury or death, property damage or economic loss.

Attentions help you:

- identify a hazard
- avoid the hazard
- recognize the consequences

Important: Identifies information that is especially important for successful application and understanding of the product.

This Page Intentionally Left Blank.

This Page Intentionally Left Blank.

This Page Intentionally Left Blank.

This Page Intentionally Left Blank.

Attach template to mounting surface
and drill four (4) 4.5mm (0.177 inches) diameter holes.
Dimensions are in millimeters [inches].

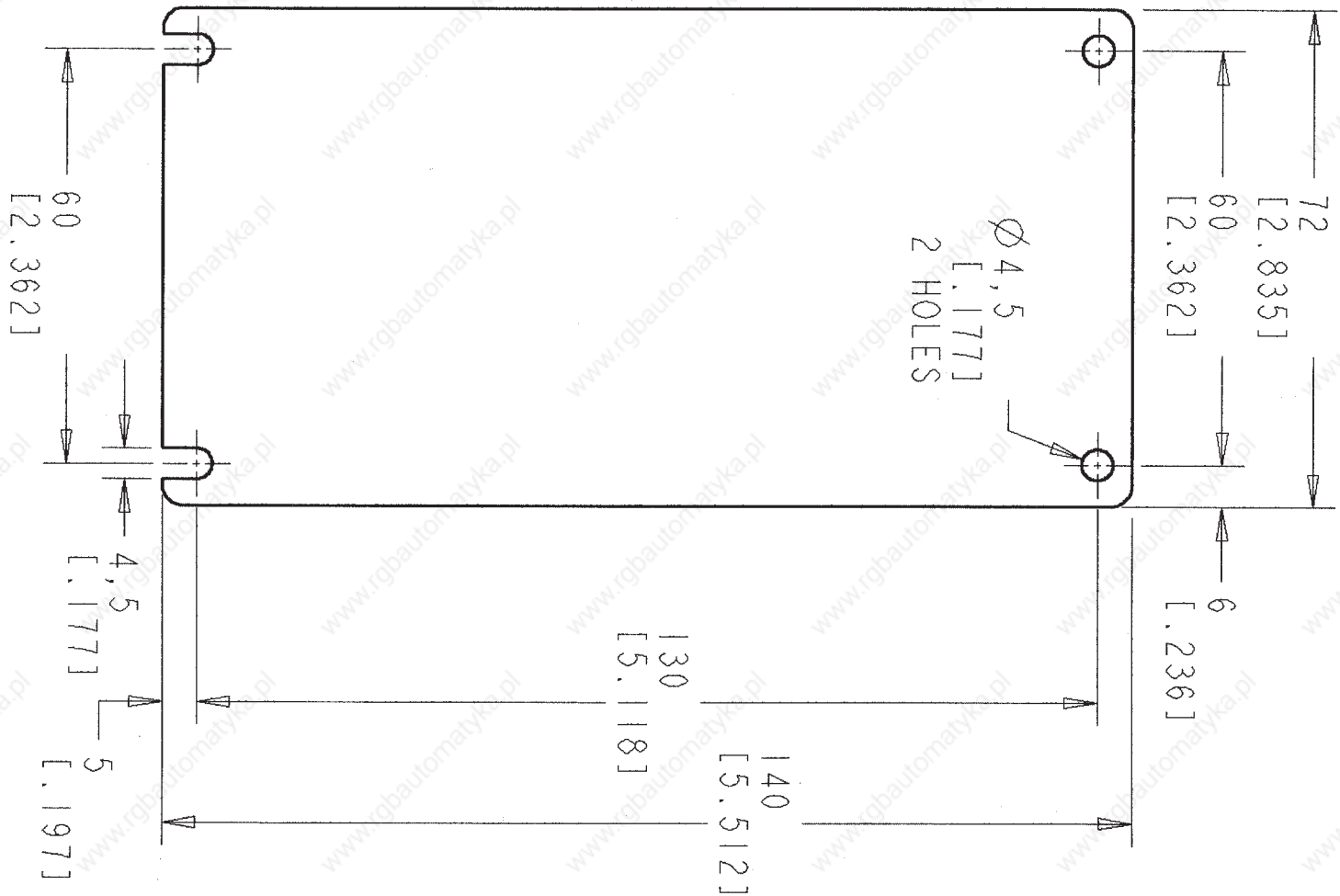

Publication 160-5.9 Summary of Changes

- The Firmware Version of the drive was changed from FRN5.01 to FRN6.0.
- The parameter **P78 – [Compensation]** was added to help eliminate non-sinusoidal motor currents that are generated by some motor/drive combinations. See page 5-12. This information was supplied previously in the form of a Document Update, Publication 160-5.9DU4, which has been eliminated.
- Firmware version FRN 6.0 includes enhancements made to the current sensing to help filter out capacitive current. These enhancements improve the overall accuracy of the drive's displayed output current. Due to this improvement, the installation of a "Reactor at Drive" is no longer recommended because it negatively effects the drive's current sensing accuracy. If an external device is required to be mounted at the drive for Reflected Wave purposes, an RWR protective device is recommended. Cable length recommendations for an "RWR at Drive" have been added to both Table 2.F and Table 2.G replacing our previous recommendations of a "Reactor at Drive".
- The paragraph titled "Recommended Line Side Protection" has been updated to provide added clarity on the use of devices other than fuses for the purposes of line side protection. Table 2.C and Table 2.D have also been updated.
- The paragraph titled "Motor Cable Recommendations" has been updated. Table 2.E was added to provide recommended cable types based on cable distances and environmental conditions.
- Part numbers and dimensional information for the new 24V DC interface module and "RF" series of line filters have been added to Appendix A.
- Publication 160-5.9DU2 has been incorporated into the manual. The contents of the document update can now be found in Appendix B.

Summary of Changes

This Page Intentionally Blank

Chapter 1 – Information and Precautions	1-1
General Information	1-1
General Precautions	1-1
Conventions Used In This Manual	1-2
Chapter 2 – Installation and Wiring	2-1
Installation and Storage	2-1
CE Compliance	2-1
Controller Features	2-1
Power Wiring For Preset Speed and Analog Signal Follower Models	2-2
Input Power Conditioning	2-2
Recommended Line Side Protection	2-3
Motor Cable Recommendations	2-4
Control Wiring Requirements	2-6
Control Wiring – Analog Signal Follower Model	2-7
Control Wiring – Preset Speed Model	2-7
Control Wiring Diagrams	2-8
Chapter 3 – Program Keypad Module	3-1
Features	3-1
Display Mode	3-1
Program Mode	3-1
Removing Program Keypad Module	3-2
Chapter 4 – Start-Up	4-1
Start-up Procedure	4-1
Chapter 5 – Parameters and Programming	5-1
Overview of Parameters	5-1
Programming Example	5-1
Display Group Parameters	5-2
Program Group Parameters	5-4
Chapter 6 – Troubleshooting and Fault Information	6-1
Fault Information	6-1
Troubleshooting	6-3
Block Diagram of Bulletin 160 Analog Signal Follower	6-4
Appendix A	
Controller Specifications	A-1
Catalog Numbers for Bulletin 160 Accessories	A-4
Controller Dimensions	A-5
Accessory Dimensions	A-6

Appendix B

CE Compliance B-1
Essential Requirements for a Conforming EMC Installation B-1
General Instructions for an EMC Compliant Installation B-2
Low Voltage Directive 73/23/EEC Compliance B-4

Index

Index I-1

General Information

Receiving – It is your responsibility to thoroughly inspect the equipment before accepting the shipment from the freight company. Check the item(s) received against the purchase order. If any items are obviously damaged, do not accept delivery until the freight agent notes the damage on the freight bill.

If you find any concealed damage during unpacking notify the freight agent. Also, leave the shipping container intact and have the freight agent make a visual inspection of the equipment in order to verify damage.

Unpacking – Remove all packing material, wedges, or braces from within and around the controller. Remove all packing material from the heat sink.

Inspection – After unpacking, check the item(s) nameplate catalog number against the purchase order. An explanation of the catalog numbering system for the Bulletin 160 controller is included as an aid for nameplate interpretation. Refer to the following page for complete nomenclature.

Important: Before you install and start up the controller, inspect the mechanical integrity of the system (e.g., look for loose parts, wires, connections, etc.).

General Precautions

In addition to the precautions listed throughout this manual, you must read and understand the following statements which are general to the system.



ATTENTION: This controller contains ESD (Electrostatic Discharge) sensitive parts and assemblies. Static control precautions are required when installing, testing, servicing or repairing this assembly. Component damage may result if ESD control procedures are not followed. If you are not familiar with static control procedures, reference A-B Publication 8000-4.5.2, “Guarding Against Electrostatic Damage” or any other applicable ESD protection handbook.



ATTENTION: Only personnel familiar with the controller and associated machinery should plan or implement the installation, start-up, and subsequent maintenance of the system. Failure to comply may result in personal injury and/or equipment damage.



ATTENTION: The surface temperatures of the controller may become hot, which may cause injury.



ATTENTION: An incorrectly applied or installed controller can result in component damage or reduction in product life. Wiring or application errors such as undersizing the motor, supplying an incorrect or an inadequate AC supply, or excessive ambient temperatures may result in system malfunction.



ATTENTION: The controller contains high voltage capacitors which take time to discharge after removal of mains supply. Before working on controller, ensure isolation of mains supply from line inputs [L1, L2, L3 (U, V, W)]. Wait one minute for capacitors to discharge to safe voltage levels. Failure to do so may result in personal injury or death.

Figure 1.1 – Catalog Number Code Explanation

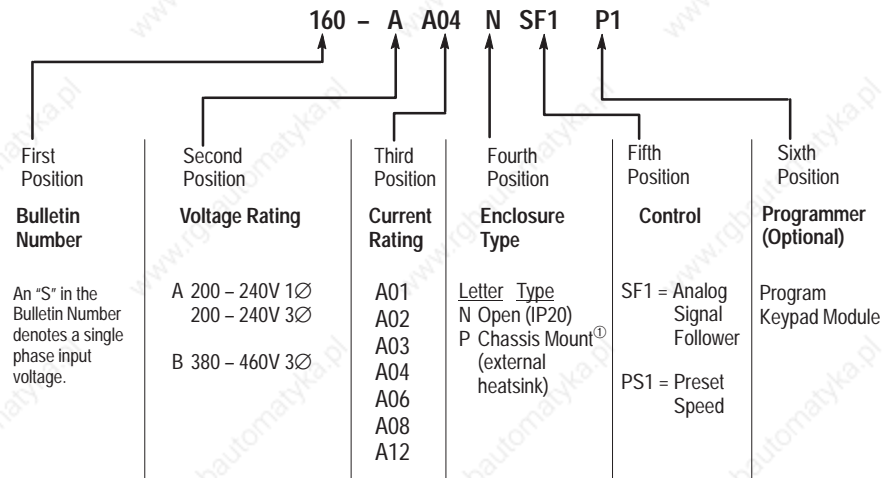

① This manual applies only to the open style (IP20) device. Refer to separate instruction sheets for Chassis Mount and NEMA 4 (IP66) devices.

Figure 1.2 – Nameplate Information

CAT160-AA04NSF1P1		SER B	FRN: 6.xx
I N P U T	V: 200-240 3Ø	O U T P U T	V: 200-230 3Ø
	A: 5.4		A: 4.5
	Hz: 50/60		Hz: 0-240 <input type="checkbox"/>
	VA: 2200		Motor Rating: 0.75kW/1HP
ALLEN-BRADLEY		MADE IN U.S.A.	

Nameplate is located on the side of the unit.

S/N 32098	
OPERATING AMBIENT TEMP: 0 – 50°C	
SHORT CIRCUIT CURRENT: 10KA	
POWER TERMINAL WIRE: Use 75°C Cu Wire	
IP20	4mm ² – .75mm ² (12 – 18 AWG.)
	Torque 1.35 Nm (12 in.-lbs.)
WARNING: ! Allow 1 Minute after power is removed before servicing. Accessible surfaces may be hot. Compatible with Type B RCD protection devices only.	

Conventions Used In This Manual

Parameter numbers and names are shown in bold typeface and follow the format PXX – [*] where P denotes parameter, XX denotes the two digit parameter number, and * represents the parameter name. For example, **P01 – [Output Frequency]**.

Installation and Storage

Take these actions to prolong controller life and performance:

- store within an ambient temperature range of -40° to $+85^{\circ}\text{C}$
- store within a relative humidity range of 0% to 95%, non-condensing
- protect the cooling fan by avoiding dust or metallic particles
- avoid storing or operating the controller where it could be exposed to a corrosive atmosphere
- protect from moisture and direct sunlight
- operate at an ambient temperature range of 0° to $+50^{\circ}\text{C}$

To maintain proper working conditions, install the controller on a flat, vertical and level surface. Use mounting screws up to 4.5mm (0.177 inches) in diameter or mount on 35mm DIN Rail.

CE Compliance

Refer to Appendix B for detailed information.

Mounting Requirements

Description	Metric	English
Min. Panel Thickness (14 GA)	1.9mm	0.0747 in.
Mounting Base Screws	m4 x 0.7	# 8-32
Mounting Torque	1.13 to 1.56 Nm.	10-14 lb. in.

- See Appendix A for details on controller dimensions and weights.
- There must be a minimum of 12.5mm (0.5 inches) clearance around all sides of the controller. Use either DIN rail or mounting holes. (Use the drilling template at the back of the manual for mounting the controller.)
- Leave debris cover attached during controller installation to protect from falling debris. To ensure proper controller operation, remove cover before applying power.

Controller Features

Figure 2.1 below details the features of both the Analog Signal Follower and Preset Speed models.

Important: The features are the same for single and three phase units.

Figure 2.1 – Controller Features

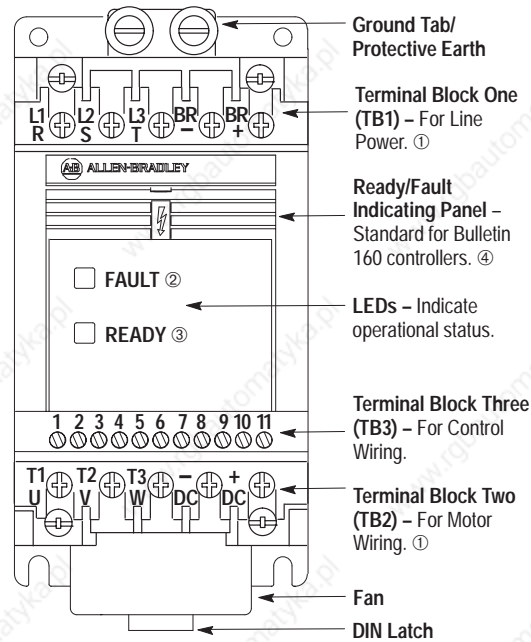



- ① Refer to Figure 2.2
- ② The **FAULT** (red) indicator illuminates when a controller fault condition exists. Refer to Chapter 6 for details on how to clear a fault and general troubleshooting procedures.
- ③ The **READY** (green) indicator illuminates when the DC bus is charged and the controller is ready to run.
- ④ Bulletin 160 controllers are fully functional when installed with a Ready/Fault indicating panel. All control functions can be performed from the control terminal block (TB3). Factory default parameter settings cannot be changed with the Ready/Fault indicating panel.

A **Program Keypad Module** can be ordered separately, Catalog 160-P1, or as a factory-installed option by adding "P1" to the end of the catalog number. Refer to Chapter 3, Program Keypad Module for a detailed explanation of functionality.

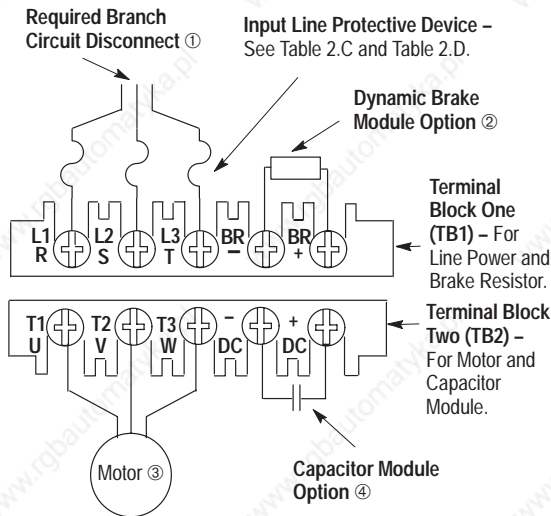
Figure 2.2 – Power Wiring For Analog Signal Follower and Preset Speed Models



- ① For single phase input applications, connect the AC input line to input terminals (L1) R and (L2) S.
- ② Connection for dynamic brake resistors for all models. **Important:** P52 – [DB Enable] must be enabled for proper operation. See Appendix A for part numbers.

- ③  and  listed as motor overload protective devices. An external overload relay is not required for single motor applications.
- ④ Connection for an external capacitor module. Provides extended ride through capability and improved inherent braking performance. See Appendix A for part number.



ATTENTION: The controller is intended to be commanded by control input signals that will start and stop the motor. A device that routinely disconnects then reapplies line power to the controller for the purpose of starting and stopping the motor should not be used. If it is necessary to use this method for starting and stopping or if frequent cycling of power is unavoidable, make sure that it does not occur more than *once* a minute.



ATTENTION: Do not connect power factor correction capacitors to controller output terminals T1, T2, and T3 (U, V, and W) or component damage could occur.

Power Wiring For Preset Speed and Analog Signal Follower Models

Table 2.A – Power Terminal Block Specifications

Terminal Block	Screw Size	Max/Min Wire Size mm ² (AWG)	Max/Min Torque Nm. (lb.in.)
TB1 ^⑤	M4	4 – 0.75 (12 – 18)	1.81 – 1.35 (16 – 12)
TB2 ^⑤	M4	4 – 0.75 (12 – 18)	1.81 – 1.35 (16 – 12)

⑤ The Bulletin 160 SSC is IP20 with wires installed on power terminal blocks.

Input Power Conditioning

The controller is suitable for direct connection to AC power lines within the rated voltage of the controller (see Appendix A). **Listed below are certain power line conditions which may cause component damage or reduction in product life.** If any of the conditions exist as described in the table below, install “one” of the devices listed under the heading “Corrective Action” on the line side of the controller. **Important:** Only one device per branch circuit is required. It should be mounted closest to the branch and sized to handle the total current of the branch circuit.

Table 2.B – Power Line Conditions

Power Line Condition	Corrective Action
Available short circuit currents (fault currents) greater than 10,000 Amps	<ul style="list-style-type: none"> • Check supply voltage. • Line Reactor (See A-4) or • Isolation Transformer
Line has power factor correction capacitors	<ul style="list-style-type: none"> • Line Reactor (See A-4) or • Isolation Transformer
Line has frequent power interruptions	<ul style="list-style-type: none"> • Line Reactor (See A-4) or • Isolation Transformer
Line has high frequency (>10 Hz) noise spikes in excess of 900V (Induction heaters, RF equipment, choppers)	<ul style="list-style-type: none"> • MOV option (See A-4) or • Line Reactor (See A-4) or • Isolation Transformer
Line has intermittent noise spikes in excess of 2000V (lightening)	<ul style="list-style-type: none"> • MOV option (See A-4) or • Line Reactor (See A-4) or • Isolation Transformer

Recommended Line Side Protection

The Bulletin 160 Smart Speed Controller has been UL tested and approved for use with a fuse, circuit breaker or manual motor starter installed on the line side of the controller. The maximum branch circuit protective rating is limited to four times the rated output current of the drive or 30 amperes, whichever is less.

The ratings in Table 2.C and Table 2.D are the “**minimum**” recommended values for use with each drive rating. It should be noted that the products listed under the column heading “Other Protective Devices” must follow the proper application guidelines stated for those products in order to meet local or national electrical codes.

When using Bulletin 140 manual motor starters or Bulletin 1492 circuit breakers the following

guidelines must be followed in order to meet the NEC requirements for branch circuit protection:

Bulletin 140 manual motor starters can be used in single and group motor applications. In single motor applications, a fuse or UL489 rated circuit breaker is required upstream from the Bulletin 140 manual motor starter. In group motor installations, the Bulletin 140 can be used for protection of an individual motor within the group and “one set” of fuses or a UL489 rated circuit breaker serves as the Short Circuit Protective Device for the entire “Group Installation”.

Bulletin 1492 circuit breakers are rated as supplementary protective devices. When using this device, upstream fuses or UL489 rated circuit breakers are required for each motor in the branch circuit regardless if it is a single or group motor installation.

Table 2.C – Minimum Recommended Line Side Protective Devices for 200 – 240V rated units

3 ∅ Rating kW (HP)	1 ∅ Rating kW (HP)	Fuse Rating	Fuse Types [®]		Other Protective Devices	
			Class CC	Class J	Rating	Type
.37 (1/2)	N/A	6			16	
.55 (3/4)	.37 (1/2)	6	KLDR/CCMR ^②	JDT ^②	16	140-MN-**** ^⑤
.75 (1)	.55 (3/4)	10	ATMR ^③	AJT ^③	16	1492-CB3-H**** ^⑥
1.5 (2)	.75 (1)	15 (16)	FNQR ^④	LPJ ^④	16	HFD ***L ^⑦
2.2 (3)	1.5 (2)	25			20	

Table 2.D – Minimum Recommended Line Side Protective Devices for 380 – 460V rated units

3 ∅ Rating kW (HP)	1 ∅ Rating kW (HP)	Fuse Rating	Fuse Types [®]		Other Protective Devices	
			Class CC	Class J	Rating	Type
.37 (1/2)	N/A	3 (4) ^①			6.3	
.55 (3/4)	N/A	3 (4) ^①	KLDR/CCMR ^②	JDT ^②	6.3	140-MN-**** ^⑤
.75 (1)	N/A	6 ^①	ATDR/ATQR ^③	AJT ^③	6.3	1492-CB3-H**** ^⑥
1.5 (2)	N/A	10	FNQR ^④	LPJ ^④	16	HFD ***L ^⑦
2.2 (3)	N/A	15 (16)			16	

① Must be dual element time delay.

② Littlefuse

③ Gould Shawmut

④ Bussman

⑤ Allen-Bradley Bulletin 140 manual motor starter. Not recommended for repetitive application of power to the input of the drive.

⑥ Allen-Bradley Bulletin 1492 circuit breaker. Not recommended for repetitive application of power to the input of the drive.

⑦ Westinghouse type HFD circuit breaker

⑧ Controller is also compatible with RK1, RK5, and BS88 fuse types.

Fuse ratings in () denote European size.

Motor Cable Recommendations

A variety of cable types are acceptable for variable speed controller installations. For many installations, *unshielded* cable is adequate, provided it can be separated from sensitive circuits. As an approximate guide, allow a spacing of 1 meter (3.3 feet) for every 10 meters (33 feet) of unshielded length. If you cannot separate motor cables from sensitive circuits, or if you must run motor cables from multiple controllers (more than three) in a common conduit or cable trays, *shielded* motor cable is recommended to reduce system noise.

Motor cables should be four-conductor with the ground lead and shield (if using shielded cable) connected to the controller ground terminal and the motor frame ground terminal.

Table 2.E provides the recommended wire type for both wet and dry installations as defined by NEC 1996 (70-31). These recommendations are based upon a variety of factors such as insulation thickness, susceptibility to moisture and susceptibility to nicks and cuts during installation.

Table 2.F – Cable Length Recommendations – Reflected Wave^②

380 – 460V Ratings	Motor Insulation Rating	Motor Cable Only				RWR at Drive ^③				Reactor at Motor			
		Shielded		Unshielded		Shielded		Unshielded		Shielded		Unshielded	
		ft.	m.	ft.	m.	ft.	m.	ft.	m.	ft.	m.	ft.	m.
2.2 kW (3 HP)	1000 Vp-p	40	12	40	12	360	110	300	92	210	64	210	64
	1200 Vp-p	60	18	60	18	360	110	600	183	260	79	260	79
	1600 Vp-p	500 ^④	152 ^④	500 ^④	152 ^④	360	110	600	183	500 ^④	152 ^④	500 ^④	152 ^④
1.5kW (2 HP)	1000 Vp-p	40	12	40	12	300	92	300	92	250	76	250	76
	1200 Vp-p	60	18	60	18	300	92	540	165	340	104	340	104
	1600 Vp-p	500 ^④	152 ^④	500 ^④	152 ^④	300	92	540	165	500 ^④	152 ^④	500 ^④	152 ^④
0.75 kW (1 HP)	1000 Vp-p	55	17	40	12	300	92	300	92	325	99	325	99
	1200 Vp-p	125	43	60	18	300	92	375	114	500	152	325	99
	1600 Vp-p	500 ^④	152 ^④	500 ^④	152 ^④	300	92	375	114	500 ^④	152 ^④	500 ^④	152 ^④
0.55 kW (0.75 HP)	1000 Vp-p	45	14	40	12	300	92	300	92	300	92	300	92
	1200 Vp-p	125	38	60	18	300	92	375	114	500	152	500	152
	1600 Vp-p	500 ^④	152 ^④	500 ^④	152 ^④	300	92	375	114	500 ^④	152 ^④	500 ^④	152 ^④
0.37 kW (0.5 HP)	1000 Vp-p	45	14	40	12	300	92	300	92	300	92	300	92
	1200 Vp-p	125	38	50	15	300	92	375	114	500	152	500	152
	1600 Vp-p	500 ^④	152 ^④	500 ^④	152 ^④	300	92	375	114	500 ^④	152 ^④	500 ^④	152 ^④

② The reflected wave data applies to all PWM frequencies 2 to 8 kHz. For 230V ratings see Table 2.G.

③ Cable lengths listed are for PWM frequencies of 2 kHz. Refer to publication 1204-5.1 for cable length recommendations at other PWM frequencies.

④ The maximum peak-to-peak voltage of the controller is 1400V due to the minimum on/off time software. Reflective Wave Testing has been done on cable lengths up to 500 feet. See Table 2.G for Capacitive Current Considerations.

Table 2.E – Recommended Cable Type(s)

Condition	Insulation Type(s)	Example(s)
Dry	PVC ^①	THHN
	XLPE	XHHW-2
Wet	XLPE	XHHW-2

① For AC line voltages in excess of 264V AC, or motor cable distances greater than 50 ft (15m), wire with XLPE insulation is recommended.

Long Motor Cable Effects

The controller should be installed as close to the motor whenever possible. Installation with long motor cables may require the addition of external devices to limit voltage reflections at the motor (reflected wave phenomena). See Table 2.F for recommendations.

Important: The use of an external device to limit reflected wave issues may effect the accuracy of the Bulletin 160 current sensing. Table 2.G provides recommended cable length due to Capacitive Current considerations.

Table 2.G – Cable Length Recommendations — Capacitive Current

380 – 460V Ratings	kHz	Motor Cable Only				RWR at Drive ^①				Reactor at Motor			
		Shielded ^②		Unshielded		Shielded ^②		Unshielded		Shielded ^②		Unshielded	
		ft.	m.	ft.	m.	ft.	m.	ft.	m.	ft.	m.	ft.	m.
2.2 kW (3 HP)	2	360	110	750	229	280	85	600	183	410	125	525	160
	4	335	102	600	183	260	79	600	183	370	113	475	145
	8	300	91	410	125	①	①	①	①	310	94	420	128
1.5 kW (2 HP)	2	300	91	540	165	430	131	540	165	310	94	425	130
	4	300	91	425	130	410	125	425	130	300	91	400	122
	8	300	91	300	91	①	①	①	①	300	91	350	107
0.75 kW (1 HP)	2	300	91	375	114	250	76	375	114	300	91	300	91
	4	300	91	300	91	225	69	375	114	300	91	300	91
	8	300	91	300	91	①	①	①	①	300	91	300	91
0.55 kW (0.75 HP)	2	300	91	375	114	250	76	375	114	300	91	300	91
	4	300	91	310	94	225	69	375	114	300	91	300	91
	8	300	91	300	91	①	①	①	①	300	91	300	91
0.37 kW (0.5 HP)	2	300	91	375	114	250	76	375	114	300	91	300	91
	4	300	91	325	99	225	69	375	114	300	91	300	91
	8	300	91	300	91	①	①	①	①	300	91	300	91

200 – 240V Ratings	Motor Cable Only				RWR at Drive				Reactor at Motor			
	Shielded		Unshielded		Shielded		Unshielded		Shielded		Unshielded	
	ft.	m.	ft.	m.	ft.	m.	ft.	m.	ft.	m.	ft.	m.
0.37 to 2.2 kW (0.5 to 3 HP) 2 thru 8 kHz	500	152	800	244	③	③	③	③	500	152	800	244

① Not recommended for use above 4 kHz PWM frequency.

② When using shielded cable at lightly loaded conditions, the 0.75 Kw (1 Hp) and below cable length recommendations are 61m (200 ft.)

③ Not recommended for 230V applications.

Control Wiring Requirements

- run all signal wiring in either a shielded cable, or a separate metal conduit.
- only connect shield wire at control terminal block **common** terminals TB3-3 and TB3-7.
- do not exceed control wiring length of 15 meters (50 feet). Control signal cable length is highly dependent on electrical environment and installation practices. To improve noise immunity the control terminal block **common** must be connected to earth ground.
- use Belden 8760 (or equivalent) — 18AWG (0.750mm²), twisted pair, shielded or 3 conductor.

Table 2.H – Control Terminal Block Specifications

Terminal Block	Max/Min Wire Size mm ² (AWG)	Max/Min Torque Nm. (lb.in.)
TB3	2.5 – 0.5 (14 – 22)	0.8 – 0.4 (8 – 4)



ATTENTION: The controller is supplied with an internal 12V supply. Dry contacts or open collectors are required for discrete control inputs. If an external voltage is applied, component damage could occur.



ATTENTION: The drive start/stop control circuitry includes solid-state components. If hazards due to accidental contact with moving machinery or unintentional flow of liquid, gas or solids exist, an additional hardwired stop circuit is required to remove AC line power to the drive. When AC input power is removed, there will be a loss of inherent regenerative braking effect and the motor will coast to a stop. An auxiliary braking method may be required.

Control Wiring – Analog Signal Follower Model

You can control the output frequency of the controller via the Control Terminal Block (TB3) using a remote potentiometer, a –10 to +10V DC analog input, a 4 – 20mA analog input, or use **P58 – [Internal Frequency]**. **Important:** Only one frequency source may be connected at a time. If the frequency reference potentiometer and the 4 – 20mA reference are connected at the same time, an undetermined frequency reference will result.

Control Wiring – Preset Speed Model

You can control the output frequency of the controller via the Control Terminal Block (TB3) using dry contacts or open collector inputs to SW1, SW2, and SW3 or use **P58 – [Internal Frequency]**. A program keypad module is required to change the factory default settings. Refer to Chapter 5, *parameters 61 – 68* for the eight preset frequency factory default settings and switch configurations.

Wiring Diagrams

Important: Refer to the diagrams on the following pages for control wiring information.

Control Wiring

Figure 2.3 – TB3 Control Wiring for Analog Signal Follower Model

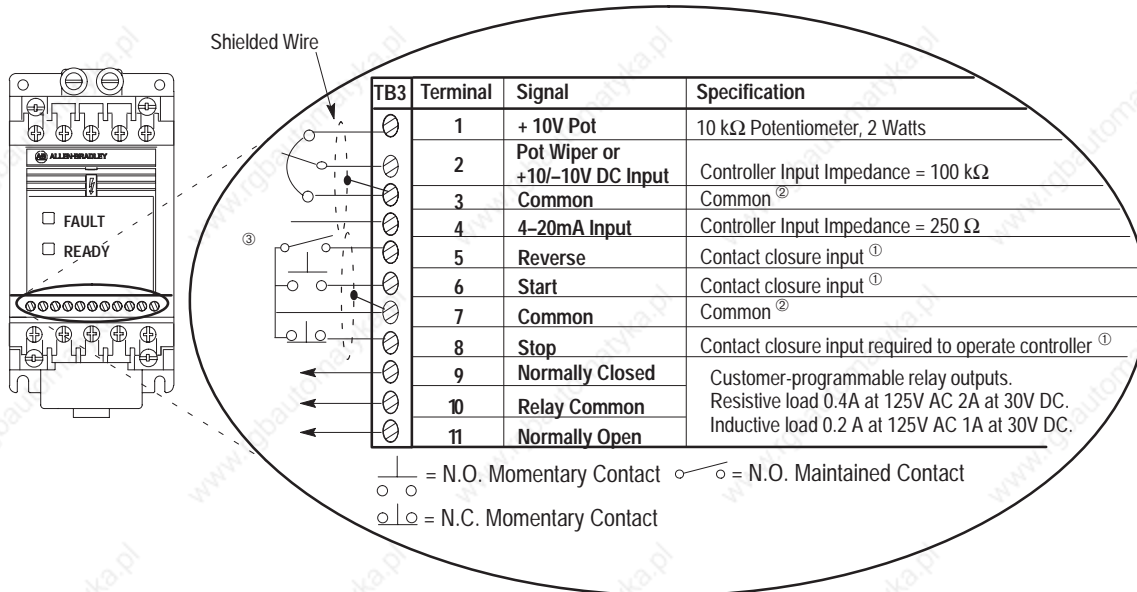
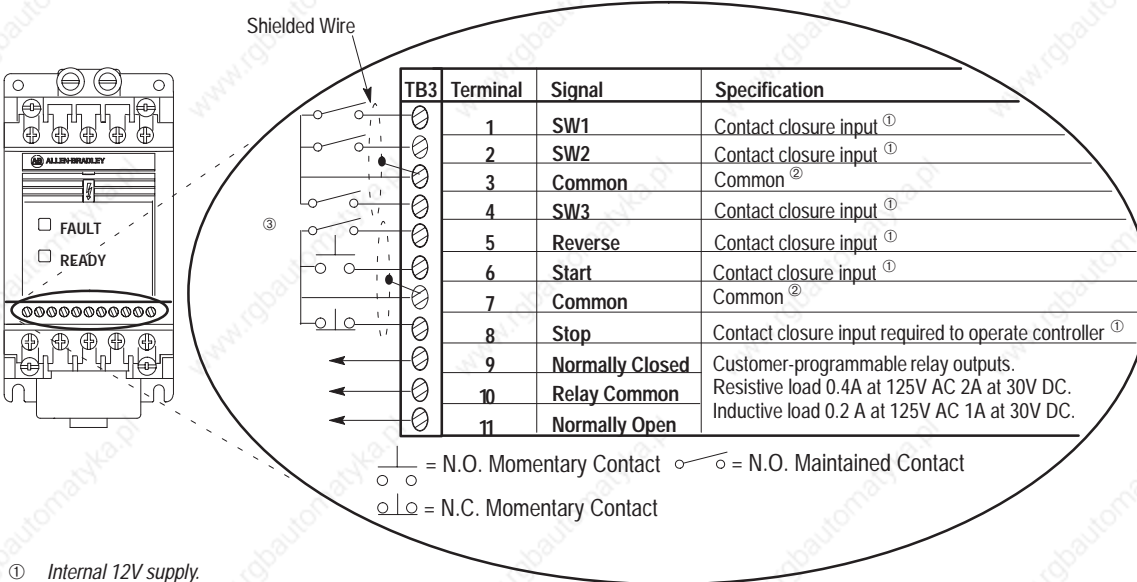

Figure 2.4 – TB3 Control Wiring for Preset Speed Model



- ① Internal 12V supply.
- ② Do not exceed control wiring length of 15 meters (50 feet). Control signal cable length is highly dependent on electrical environment and installation practices. To improve noise immunity the control terminal block **common** must be connected to earth ground.
- ③ This diagram shows "three wire" control. Refer to the following page for diagrams of other control wiring methods.





Control Wiring (continued)

Use **P46** – [Input Mode] to select the control method for start, stop, and direction control.

Important: Settings 4 through 6 provide additional flexibility of TB3 control input terminal 8.

- Setting 0 — Three Wire Control. (This is the factory default setting). Refer to Figure 2.5.
- Setting 1 — Two Wire “Run Forward/Run Reverse” Control. Refer to Figure 2.6.
- Setting 2 — Program Keypad Module control. See Page 3-1.
- Setting 3 — Momentary “Run Forward/Run Reverse” control. Refer to Figure 2.7.
- Setting 4 — Two Wire “Accel/Decel” control. Refer to Figure 2.8.
- Setting 5 — Two Wire “Enable” control. Refer to Figure 2.9.
- Setting 6 — Two Wire “Local/Remote” control. Refer to Figure 2.10.

Explanation of Symbols:

-  = N.O. Momentary Contact
-  = N.C. Momentary Contact
-  = N.O. Maintained Contact
-  = N.C. Maintained Contact

- ① Internal 12V supply.
- ② If both Run Forward and Run Reverse inputs are closed at the same time an undetermined state could occur.
- ③ Do not exceed control wiring length of 15 meters (50 feet). Control signal cable length is highly dependent on electrical environment and installation practices. To improve noise immunity the control terminal block common must be connected to earth ground.

Figure 2.5 – TB3 Three Wire control (Setting 0) (Factory Default Setting)

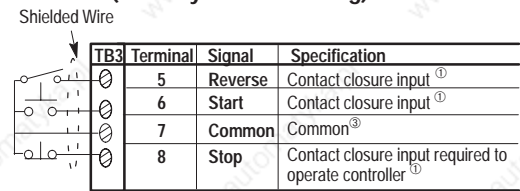

Important: After a Stop input, the Start input must be toggled to Run again.

Figure 2.6 – TB3 Two Wire “Run Forward/Run Reverse” control (Setting 1)

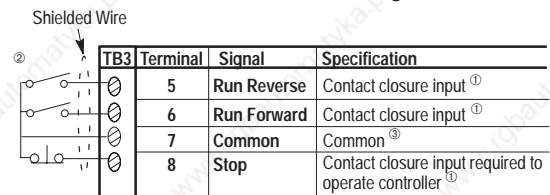

Important: The “Run” inputs must be maintained. After a Stop input, either a Run Forward or a Run Reverse input must be toggled to run again.

Figure 2.7 – TB3 Momentary “Run Forward/Run Reverse” control (Setting 3)

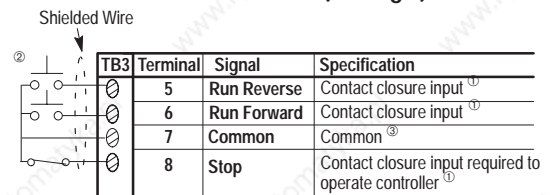

Important: The “Run” inputs do not need to be maintained. After a stop input, either a Run Forward or a Run Reverse input does not need to be toggled to run again.



ATTENTION: Hazard of injury exists due to unintended operation. When **P46** – [Input Mode] is set to “3” and the “Run” input is maintained, a stop function is provided only when the stop input is active (open).

Control Wiring (continued)

Figure 2.8 – TB3 Two Wire “Accel/Decel” control (Setting 4)

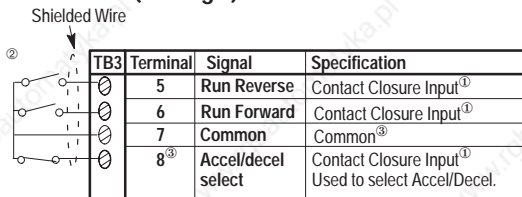

③ Refer to Figure 2.11.

Figure 2.9 – TB3 Two Wire “Enable” control (Setting 5)

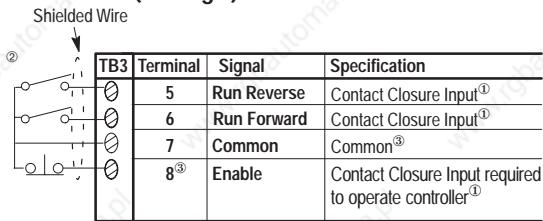

③ Refer to Figure 2.11.

Figure 2.10 – TB3 Two Wire “Local/Remote” control (Setting 6)

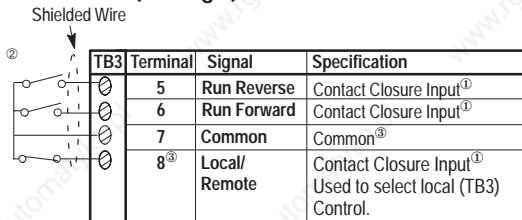

③ Refer to Figure 2.11.

Figure 2.11

Input Mode Setting	TB3-8 Open	TB3-8 Closed
4 ^④	Accel 2 ^⑤ Decel 2	Accel 1 Decel 1
5 ^④	Controller ^⑥ Disabled	Controller Enabled
6 ^④	Local (TB3) ^⑦ Control	Remote Control

④ The “Run” input must be a maintained input. After a stop command, either a “Run Forward” or “Run Reverse” input must be toggled to start the controller.

⑤ When this input is in an open state, P69 – [Accel Time 2] and P70 – [Decel Time 2] are active.

⑥ When this input is in an open state, all power is removed from the motor and it will “coast to rest”.

⑦ When this input is in an open state the Frequency source is always from the terminal block regardless of the setting of P59 – [Frequency Select].

Important: In modes 4 through 6, Terminal TB3-8 is also used to clear faults. See Figure 2.12 for details.

Important: The system programmer is responsible for returning terminal TB3-8 to its original state if necessary.

Figure 2.12

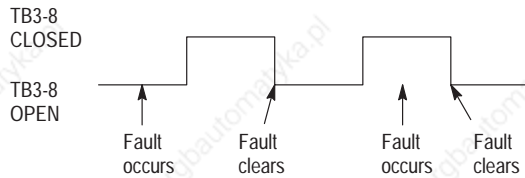

This Page Intentionally Blank

Features

The program keypad module is located on the front panel of the controller. It features the following:

- five keys on the module for display or programming controller parameters
- three keys for control inputs to the controller
- directional LEDs
- a 6 digit, seven segment LED display

Display Mode

The controller always powers up in the display mode. While in this mode you may view all read only controller parameters, but not modify them.

Program Mode

You enter the program mode by pressing the ESC key. While in program mode, you can edit any programmable controller parameters. Refer to Chapter 5 for programming steps.

Figure 3.1 – Program Keypad Module Features

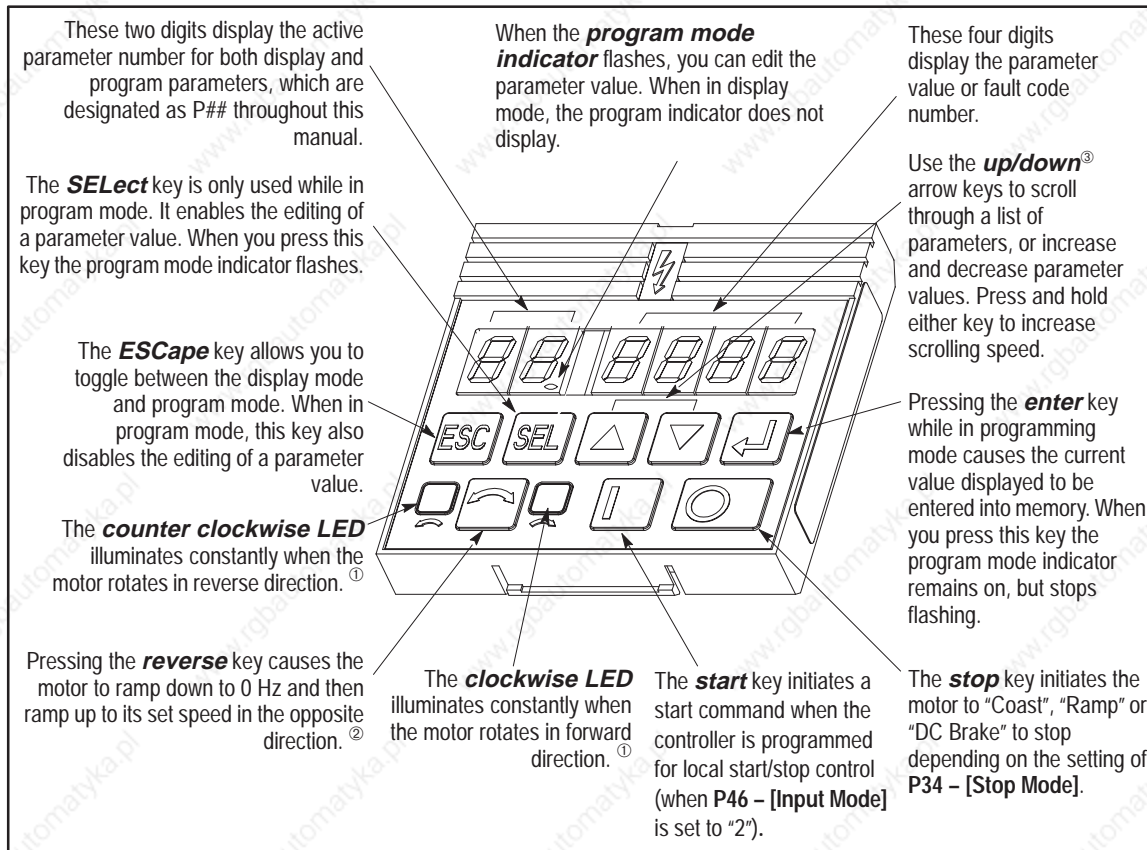

^① Indicates commanded direction. Actual motor rotation could be different if motor leads are not connected properly. See Chapter 4, Start-up for details on how to verify motor rotation.
^② When the motor is running, pressing this key causes the (currently illuminated) LED to flash indicating motor rotation while

decelerating to zero. The opposite LED will illuminate indicating the commanded direction.
^③ Real time frequency adjustment can be achieved when using P58 – [Internal Frequency].

Removing Program Keypad Module



ATTENTION: Ensure that you disconnect line power and wait one minute before installing or removing the program keypad module. Failure to do so may result in personal injury or death.



ATTENTION: This controller contains ESD (Electrostatic Discharge) sensitive parts and assemblies. Static control precautions are required when installing, testing, servicing or repairing this assembly. Component damage may result if ESD control procedures are not followed. If you are not familiar with static control procedures, reference A-B Publication 8000-4.5.2, “Guarding Against Electrostatic Damage” or any other applicable ESD protection handbook.

Figure 3.2 – Removing Program Keypad Module

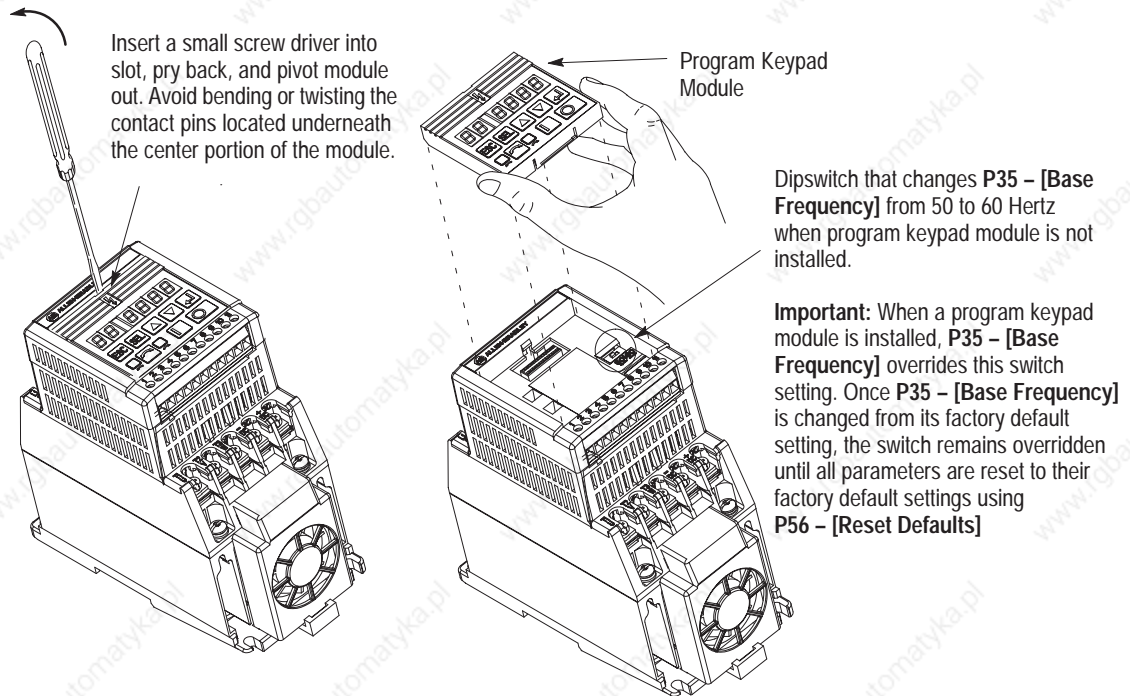

Installing Program Keypad Module

Insert the module bottom end first and then press on the  symbol at the top of the module until the module is fully seated. The module is fully seated when its face is flush with the edges of its surrounding case.

Chapter 5 provides a comprehensive description of all controller parameters. Review the factory default settings. If your controller is equipped with a Program Keypad Module these parameters can be changed to meet your specific application requirements. An example of how to program a parameter is shown at the beginning of Chapter 5.

Commonly Changed Parameters

Parameter	Set to...
P30 – [Accel Time 1]	desired accel time.
P31 – [Decel Time 1]	desired decel time.
P33 – [Maximum Frequency]	maximum frequency required.
P34 – [Stop Mode Select]	desired stopping mode.
P35 – [Base Frequency]	motors rated nameplate frequency.
P36 – [Base Voltage]	motors rated nameplate voltage.
P42 – [Motor Overload Current]	motor nameplate Full Load Amps [FLA].
P46 – [Input Mode]	desired control method.
P47 – [Output Configure]	desired output functionality.
<i>Preset Speed Model Only</i>	
P61 – P68 – [Preset Frequency 0–7]	desired preset frequencies.

Start Here

ATTENTION: Power must be applied to the controller to perform the following start-up procedure. Some of the voltages present are at incoming line potential. To avoid electric shock hazard or damage to equipment, only **qualified service personnel** should perform the following procedure. Thoroughly read and understand the procedure before beginning. If an event does not occur while performing this procedure, **Do Not Proceed. Remove Power** by opening the branch circuit disconnect device and correct the malfunction before continuing.

Start-Up Checklist
 Verify the controller is installed per instructions outlined in Chapter 2 including:

- Minimum clearance distance between controller and other equipment.
- Proper grounding practices have been followed.
- Proper power and control wiring has been used.

Verify that AC line power at the disconnect device is within the rated value of the controller.

Disconnect and lock out all incoming power to the controller including incoming AC power to terminals L1, L2 and L3 (R, S and T) of power terminal block TB1.

ATTENTION: A DC Bus voltage may be present at the power terminal blocks (TB1) and (TB2) for approximately one minute after power is removed from the controller.

Verify that the motor leads are connected to the power terminal block TB2, terminals T1, T2, T3 (U, V, W).

Verify that the **STOP** input is present at the TB3 control terminal block. See page 2-9 for details on TB3-8 functionality when using **P46 – [Input Mode]** settings 4 through 6.

Confirm that all other control inputs are connected to the correct terminals and are secure. **GO TO THE NEXT PAGE.**

A

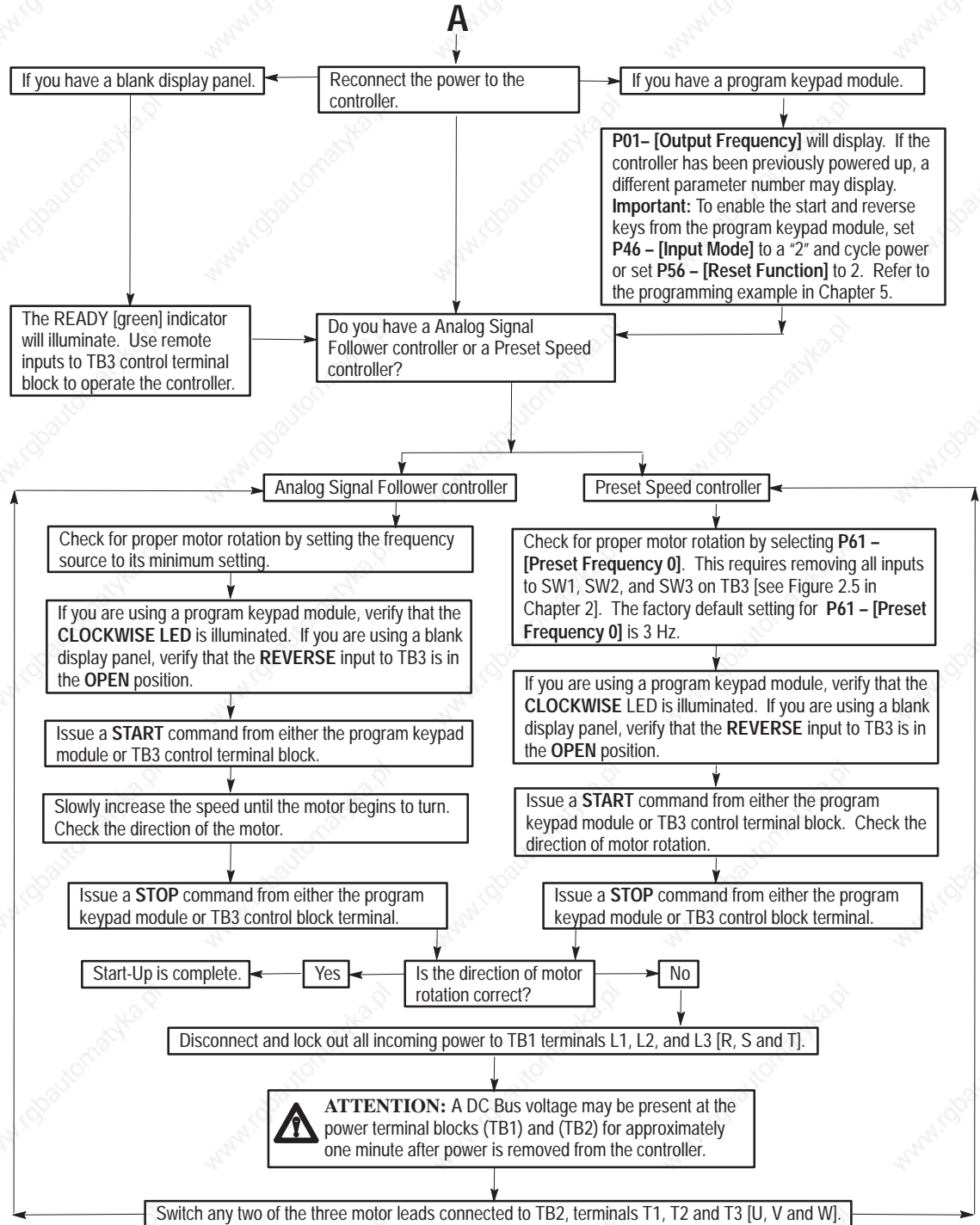

Overview of Parameters

This chapter covers both *display* and *program* parameters. *Display* parameters are **read only** (they cannot be programmed), while *program* parameters **can be changed** to fit your motor control requirements. You must have a Program Keypad Module to view/change *display* and *program* parameters. The table below describes which parameters apply to the Preset Speed and Analog Signal Follower models. Refer to the programming example below for programming instructions.

Parameter Type	Parameter Numbers	
	Analog Signal Follower Model	Preset Speed Model
Display	1 through 14 and 16	1 through 15
Program	30 through 60 and 69 through 76, 78	30 through 59 and 61 through 73, 78









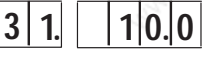

The following pages contain descriptions of both display and program parameters. Any parameter description that is shaded pertains only to the Preset Speed or Analog Signal Follower model. Refer to the legend to the right.

= Parameter applies only to the Analog Signal Follower model
 = Parameter applies only to the Preset Speed model

Programming Example

The following is an example of the programming steps required to change a *program group* parameter setting. In this example, parameter 31 – [Decel Time] is changed from its factory default setting of 10.0 seconds to 2.2 seconds. Refer to Chapter 3, Figure 3.1 on page 3-1 for an explanation of Program Keypad Module display and programming keys.

Important: To reset ALL values to original factory default settings, refer to P56 – [Reset Defaults].

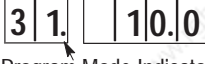
Action	Description	Keypad Display
	1. To program the value of a <i>program group</i> parameter, enter the program group by pressing the ESCape key. The “program mode indicator” will illuminate.	 Program Mode Indicator
	2. Press up/down keys until the desired parameter displays. In this case, press the up key until parameter 31 – [Decel Time] displays.	
	3. Press the SElect key. The program mode indicator flashes indicating that you can use the up/down keys to change the parameter value.	 Program Mode Indicator Flashes
	4. Change the decel time value from the factory default of 10 seconds to 2.2 seconds by pressing the down key until 2.2 displays.	
	5. When the desired value displays, press the ENTER key. This writes the new value to memory. The program mode indicator will stop flashing and the display will flash once indicating that the new value has been accepted.	 Program Mode Indicator Stops Flashing
	Important: If at any time (while in the program mode) you wish to abort the editing process, press the ESCape key. The original value of the parameter will remain unchanged and you will be exited from the program mode.	 Program Mode Indicator Stops Flashing

Display Group Parameters

This group of parameters consists of commonly viewed controller operating conditions such as controller output frequency, output voltage, output current and frequency command. All parameters in this group are *read only*.

Important: The last user selected Display Group parameter will be saved on power down.

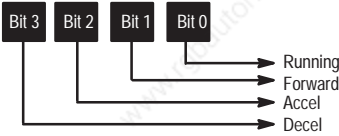
Display Group			
P#	Parameter Description	Min/Max Range	Units
01	[Output Frequency] Displays the output frequency at TB2 terminals T1, T2 and T3 (U, V and W).	0 to 240	0.1 Hz
02	[Output Voltage] Displays the output voltage present at TB2 terminals T1, T2 and T3 (U, V and W).	0 to [Max Voltage]	1 Volt
03	[Output Current] Displays the output current present at TB2 terminals T1, T2 and T3 (U, V and W).	0 to 2 Times Controller Rated Output Current	0.01Amps
04	[Output Power] Displays the output power present at TB2 terminals T1, T2 and T3 (U, V and W).	0 to 2 Times Rated Controller Output Power	0.01 kW
05	[Bus Voltage] Displays the DC Bus Voltage level.	0 to 400 – [230V] 0 to 800 – [460V]	1 Volt
06	[Frequency Command] Displays the frequency that the controller is commanded to output. This command may come from any of the frequency sources selected by P59 – [Frequency Select] or from a currently selected preset frequency.	0 to 240	0.1 Hz
07	[Last Fault] Displays the coded last fault number. If a fault is currently active (has not been cleared) the display will flash. See Chapter 6 for fault code descriptions.	0 to 49	Numeric Value
08	[Heatsink Temperature] Displays the temperature of the controller heatsink.	0 to 150	1 Degree C
09	<p>[Controller Status] Displays the status of the controller in a binary coded format.</p> <p>Important: A "0" = inactive and a "1" = active.</p> 	0000 to 1011	Binary Number
10	[Controller Type] Used by Rockwell Automation field service personnel.	Numeric Value	Numeric Value
11	[Control Version] Displays version of controller firmware. Used by Rockwell Automation field service personnel.	Fixed Value	Numeric Value

Display Group

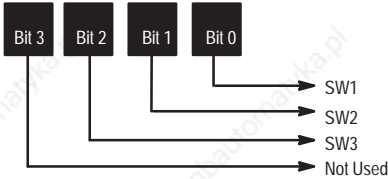
P#	Parameter Description	Min/Max Range	Units																																								
12	<p>[Input Status] Displays the open (0) and closed (1) state of the inputs to TB3 in binary coded format as follows:</p> <div style="text-align: center;">  </div> <table border="1" style="width: 100%; border-collapse: collapse; margin-top: 10px;"> <thead> <tr> <th></th> <th style="text-align: center;">Input Mode 0 (3-Wire)</th> <th style="text-align: center;">Input Mode 1 (2-Wire)</th> <th style="text-align: center;">Input Mode 2 (Keypad)</th> <th style="text-align: center;">Input Mode 3 (Momentary Run FWD/ Run REV)</th> <th style="text-align: center;">Input Mode 4 (Accel/ Decel)</th> <th style="text-align: center;">Input Mode 5 (Enable)</th> <th style="text-align: center;">Input Mode 6 (Local/ Remote)</th> </tr> </thead> <tbody> <tr> <td style="text-align: center;">Bit 0 TB3-5</td> <td style="text-align: center;">Reverse</td> <td style="text-align: center;">Run Reverse</td> <td style="text-align: center;">N/A</td> <td style="text-align: center;">Run Reverse</td> <td style="text-align: center;">Run Reverse</td> <td style="text-align: center;">Run Reverse</td> <td style="text-align: center;">Run Reverse</td> </tr> <tr> <td style="text-align: center;">Bit 1 TB3-8</td> <td style="text-align: center;">Stop</td> <td style="text-align: center;">Stop</td> <td style="text-align: center;">Stop</td> <td style="text-align: center;">Stop</td> <td style="text-align: center;">0=Accel 2/ Decel 2 1=Accel 1/ Decel 1</td> <td style="text-align: center;">0=Drive Disable 1=Drive Enable</td> <td style="text-align: center;">0=Local (TB3) Control 1=Remote Control</td> </tr> <tr> <td style="text-align: center;">Bit 2 TB3-6</td> <td style="text-align: center;">Start</td> <td style="text-align: center;">Run Forward</td> <td style="text-align: center;">N/A</td> <td style="text-align: center;">Run Forward</td> <td style="text-align: center;">Run Forward</td> <td style="text-align: center;">Run Forward</td> <td style="text-align: center;">Run Forward</td> </tr> <tr> <td style="text-align: center;">Bit 3 Polarity</td> <td colspan="7" style="text-align: center;">0 = Positive Analog Input 1 = Negative Analog Input</td> </tr> </tbody> </table>		Input Mode 0 (3-Wire)	Input Mode 1 (2-Wire)	Input Mode 2 (Keypad)	Input Mode 3 (Momentary Run FWD/ Run REV)	Input Mode 4 (Accel/ Decel)	Input Mode 5 (Enable)	Input Mode 6 (Local/ Remote)	Bit 0 TB3-5	Reverse	Run Reverse	N/A	Run Reverse	Run Reverse	Run Reverse	Run Reverse	Bit 1 TB3-8	Stop	Stop	Stop	Stop	0=Accel 2/ Decel 2 1=Accel 1/ Decel 1	0=Drive Disable 1=Drive Enable	0=Local (TB3) Control 1=Remote Control	Bit 2 TB3-6	Start	Run Forward	N/A	Run Forward	Run Forward	Run Forward	Run Forward	Bit 3 Polarity	0 = Positive Analog Input 1 = Negative Analog Input							0000 to 1111	Binary Number
	Input Mode 0 (3-Wire)	Input Mode 1 (2-Wire)	Input Mode 2 (Keypad)	Input Mode 3 (Momentary Run FWD/ Run REV)	Input Mode 4 (Accel/ Decel)	Input Mode 5 (Enable)	Input Mode 6 (Local/ Remote)																																				
Bit 0 TB3-5	Reverse	Run Reverse	N/A	Run Reverse	Run Reverse	Run Reverse	Run Reverse																																				
Bit 1 TB3-8	Stop	Stop	Stop	Stop	0=Accel 2/ Decel 2 1=Accel 1/ Decel 1	0=Drive Disable 1=Drive Enable	0=Local (TB3) Control 1=Remote Control																																				
Bit 2 TB3-6	Start	Run Forward	N/A	Run Forward	Run Forward	Run Forward	Run Forward																																				
Bit 3 Polarity	0 = Positive Analog Input 1 = Negative Analog Input																																										
13	<p>[Power Factor Angle] Displays the angle in electrical degrees between motor voltage and motor current.</p>	0.0 to 180.0	0.1 degrees																																								
14	<p>[Memory Probe Display] Used by Rockwell Automation field service personnel.</p>	Numeric Value	Numeric Value																																								
15	<p>[Preset Status] Displays the open (0) and closed (1) state of Terminal Block Three (TB3) inputs SW1, SW2, and SW3 in binary coded format. This parameter applies to the Preset Speed model only.</p> <div style="text-align: center; margin-top: 10px;">  </div>	0000 to 0111	Binary Number																																								
16	<p>[Analog Input] Displays the analog input as a percent of full scale. Used in setting P60 – [Zero Offset], P75 – [Analog Input Minimum], and P76 – [Analog Input Maximum]. Important: On initial set up of the controller, apply a 0V or 4mA analog command to the controller. Once applied, if the value of this parameter displays something other than zero, program that value into P60 – [Zero Offset]. Important: The value of the [Zero Offset] will be subtracted from the value of this parameter.</p>	-150 to +150.0	0.1%																																								

= This parameter applies only to the Preset Speed model.

= This parameter applies only to the Analog Signal Follower model.

Program Group Parameters

This group contains parameters whose values *can* be programmed. Refer to the “Programming Example” outlined earlier in this chapter. Unless otherwise stated, parameters that are programmed while the controller is running take immediate effect.

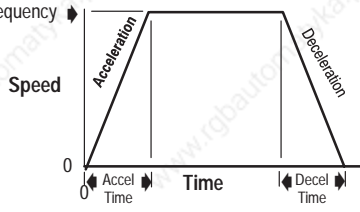
Program Group				
P#	Parameter Description	Min/Max Range	Units	Factory Default
30	<p>[Accel Time 1] Time for the controller to ramp from 0.0 Hz. to P33 – [Maximum Frequency]. The rate is linear for any increase in command frequency unless P53 – [S-Curve] is set to a value other than “0”. Setting this to 0.0 sec. gives 0.1 sec acceleration with the initial current limit turned off. This allows quicker acceleration times for low inertia systems. For medium to high inertia systems, the minimum value should be 0.1 sec.</p> 	0.0 to 600	0.1 Seconds	10.0 Seconds
31	<p>[Decel Time 1] Time for the controller to ramp from P33 – [Maximum Frequency] to 0.0 Hz. The rate is linear for any decrease in command frequency unless P53 – [S-Curve] is set to a value other than “0”. See P30 – [Accel Time 1] figure above.</p>	0.1 to 600	0.1 Seconds	10.0 Seconds
32 ^①	<p>[Minimum Frequency] Lowest frequency that controller will output continuously.</p>	0 to 240	1 Hz	0 Hz
33 ^①	<p>[Maximum Frequency] Highest frequency the controller will output. Important: This parameter can't be changed while running.</p>	0 to 240	1 Hz	60 Hz
34	<p>[Stop Mode Select] Determines stopping mode used by the controller when a stop is initiated. Refer to the P44 – [DC Hold Time] and P45 – [DC Hold Voltage] diagrams. Settings: 0 = Ramp to Stop 1 = Coast to Stop 2 = DC Injection Braking 3 = DC Injection Braking (w/Auto Shutoff) Important: DC Injection braking with auto shutoff: works the same as standard DC injection braking except that it may shut off before the P44 – [DC Hold Time]. This occurs if the controller is out of current limit before the P44 – [DC Hold Time] expires.</p>	0 to 3	Numeric Value	0
35	<p>[Base Frequency] Set value to motor's rated nameplate frequency.</p>	10 to 240	1 Hz	60 Hz ^②
36	<p>[Base Voltage] Set value to motor's rated nameplate voltage.</p>	20 to 460 for 460V units and 20 to 230 for 230V units	1 Volt	460 Volts for 460V units and 230 for 230V units

① The analog inputs to the controller (i.e., 4–20mA, 0 to +10V, or remote potentiometer) can be scaled to P32 – **[Minimum Frequency]** and P33 – **[Maximum Frequency]** by programming P75 – **[Analog Input Minimum]** and P76 – **[Analog Input Maximum]**.

② For controllers without a program keypad module, you can change P35 – **[Base Frequency]** to 50 Hz via a dipswitch located under the blank front panel. See the Removing Program Keypad Module section in Chapter 3.

Program Group

P#	Parameter Description	Min/Max Range	Units	Factory Default																														
37	[Maximum Voltage] Sets the highest voltage that the controller will output. P37 – [Maximum Voltage] must be greater than or equal to P36 – [Base Voltage].	20 to 510 for 460V units and 20 to 255 for 230V units	1 Volt	460 Volts for 460V units and 230 for 230V units																														
38	<p>[Boost Select] Sets the boost voltage and redefines the Volts per Hz curve.</p> <table border="1"> <thead> <tr> <th>Setting</th> <th>Boost Voltage % of [Base Voltage]</th> </tr> </thead> <tbody> <tr><td>0</td><td>0</td></tr> <tr><td>1</td><td>2.5</td></tr> <tr><td>2</td><td>5.0</td></tr> <tr><td>3</td><td>7.5</td></tr> <tr><td>4</td><td>10.0</td></tr> <tr><td>5</td><td>12.5</td></tr> <tr><td>6</td><td>15.0</td></tr> <tr><td>7</td><td>17.5</td></tr> <tr><td>8</td><td>20.0</td></tr> </tbody> </table> <table border="1"> <thead> <tr> <th>Setting</th> <th>Fan/Pump Curves ^①</th> </tr> </thead> <tbody> <tr><td>9</td><td>45.0</td></tr> <tr><td>10</td><td>40.0</td></tr> <tr><td>11</td><td>35.0</td></tr> <tr><td>12</td><td>30.0</td></tr> </tbody> </table> <p>^① Break Point Voltages in % of [Base Voltage].</p>	Setting	Boost Voltage % of [Base Voltage]	0	0	1	2.5	2	5.0	3	7.5	4	10.0	5	12.5	6	15.0	7	17.5	8	20.0	Setting	Fan/Pump Curves ^①	9	45.0	10	40.0	11	35.0	12	30.0	0 to 12	Numeric Value	2
Setting	Boost Voltage % of [Base Voltage]																																	
0	0																																	
1	2.5																																	
2	5.0																																	
3	7.5																																	
4	10.0																																	
5	12.5																																	
6	15.0																																	
7	17.5																																	
8	20.0																																	
Setting	Fan/Pump Curves ^①																																	
9	45.0																																	
10	40.0																																	
11	35.0																																	
12	30.0																																	
39	<p>[Skip Frequency] Works in conjunction with P40 – [Skip Frequency Band] creating a range of frequencies at which the controller will not operate continuously.</p>	0 to 240	1 Hz	240 Hz																														
40	[Skip Frequency Band] Determines the band around the P39 – [Skip Frequency] parameter. The actual band width will be 2 times [Skip Frequency Band] – 1/2 the band above and 1/2 the band below. A value of zero will disable the skip frequency.	0 to 30	1 Hz	0 Hz																														

Program Group				
P#	Parameter Description	Min/Max Range	Units	Factory Default
41	<p>[Motor Overload Select] Selects the derating factor for the I²t overload function.</p> <div style="display: flex; justify-content: space-around;"> <div style="text-align: center;"> <p>No Derating</p> </div> <div style="text-align: center;"> <p>Min Derating</p> </div> <div style="text-align: center;"> <p>Max Derating</p> </div> </div> <p>Settings: 0 = No Derating 1 = Minimum Derating 2 = Maximum Derating</p>	0 to 2	Numeric Value	0
42	<p>[Motor Overload Current] Set to motor nameplate full load Amps (FLA).</p>	0.1 to 200% of controller rating	.01 Amperes	115% of Controller Rating
43	<p>[Current Limit] Maximum output current allowed before current limiting occurs. Value set in percent of controller rated output current.</p>	1 to 180% of controller rating	1 %	150%
44	<p>[DC Hold Time] Time that P45 – [DC Hold Voltage] will be applied to the motor when P34 – [Stop Mode Select] is set to either “DC Injection Braking” or “Ramp to Stop” mode.</p>	0 to 25	0.1 Second	0 Seconds
45	<p>[DC Hold Voltage] DC Voltage level applied to the motor during braking when P34 – [Stop Mode Select] is set to either “DC Injection Braking” or “Ramp to Stop” mode.</p> <p>Important: If the current exceeds P43 – [Current Limit] the voltage applied to the motor will be less than this setting.</p>	0 to 115	1 Volt	0 Volts

Ramp to Stop Mode

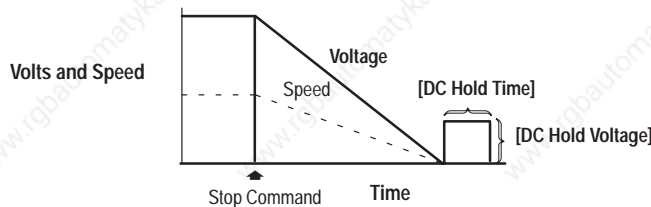

DC Injection Braking Mode

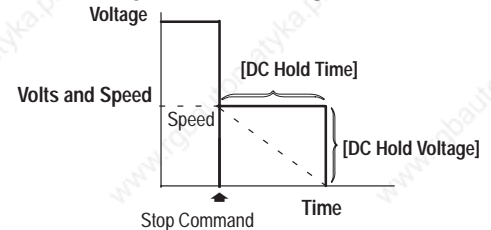

Program Group																										
P#	Parameter Description	Min/Max Range	Units	Factory Default																						
46	<p>[Input Mode] Configures the TB3 control inputs for various “3 wire” or “2 wire run-fwd/run-rev control” schemes. Also enables/disables the program keypad module input control. Important: This parameter cannot be programmed while the controller is running. Also, power must be cycled or P56 – [Reset Function] must be set to “2” for the change to take effect.</p> <p>Settings:</p> <ul style="list-style-type: none"> 0 = “3 wire” control 1 = “2 wire” control 2 = Program Keypad Module control 3 = Momentary “Run Forward/ Run Reverse” control 4 = 2 wire “Accel/Decel” control 5 = 2 wire “Enable” control 6 = 2 wire “Local/Remote” control <p>See Chapter 2 for wiring diagrams and description of settings.</p>	0 to 6	Numeric Value	0																						
47	<p>[Output Configure] Configures the TB3 relay output functionality.</p> <table border="1" style="width: 100%; border-collapse: collapse;"> <thead> <tr> <th style="width: 25%;">Settings</th> <th>Output changes state when...</th> </tr> </thead> <tbody> <tr> <td>0 = <i>Controller Ready/Faulted</i></td> <td>energized and returns to shelf state when power is removed or when a fault occurs.</td> </tr> <tr> <td>1 = <i>At Frequency</i></td> <td>the controller reaches commanded frequency.</td> </tr> <tr> <td>2 = <i>Controller Running</i></td> <td>the controller is running.</td> </tr> <tr> <td>3 = <i>Reverse</i></td> <td>the controller is commanded to run in the reverse direction.</td> </tr> <tr> <td>4 = <i>Motor Overload</i></td> <td>when a motor overload condition exists.</td> </tr> <tr> <td>5 = <i>Ramp Regulated</i></td> <td>the ramp regulator is modifying the programmed accel/decel times to avoid an overcurrent or overvoltage fault from occurring.</td> </tr> <tr> <td>6 = <i>Above Frequency</i></td> <td>the controller exceeds the frequency value set in P48 – [Output Threshold].</td> </tr> <tr> <td>7 = <i>Above Current</i></td> <td>the controller exceeds the value set in P48 – [Output Threshold]. Important: Value for P48 – [Output Threshold] must be entered in % of controller rated output current.</td> </tr> <tr> <td>8 = <i>Above DC Bus Voltage</i></td> <td>the controller exceeds the DC bus voltage value set in P48 – [Output Threshold].</td> </tr> <tr> <td>9 = <i>Retries Exhausted</i></td> <td>the number of retries for P50 – [Restart Tries] is exceeded.</td> </tr> </tbody> </table>	Settings	Output changes state when...	0 = <i>Controller Ready/Faulted</i>	energized and returns to shelf state when power is removed or when a fault occurs.	1 = <i>At Frequency</i>	the controller reaches commanded frequency.	2 = <i>Controller Running</i>	the controller is running.	3 = <i>Reverse</i>	the controller is commanded to run in the reverse direction.	4 = <i>Motor Overload</i>	when a motor overload condition exists.	5 = <i>Ramp Regulated</i>	the ramp regulator is modifying the programmed accel/decel times to avoid an overcurrent or overvoltage fault from occurring.	6 = <i>Above Frequency</i>	the controller exceeds the frequency value set in P48 – [Output Threshold].	7 = <i>Above Current</i>	the controller exceeds the value set in P48 – [Output Threshold]. Important: Value for P48 – [Output Threshold] must be entered in % of controller rated output current.	8 = <i>Above DC Bus Voltage</i>	the controller exceeds the DC bus voltage value set in P48 – [Output Threshold].	9 = <i>Retries Exhausted</i>	the number of retries for P50 – [Restart Tries] is exceeded.	0 to 9	Numeric Value	0
Settings	Output changes state when...																									
0 = <i>Controller Ready/Faulted</i>	energized and returns to shelf state when power is removed or when a fault occurs.																									
1 = <i>At Frequency</i>	the controller reaches commanded frequency.																									
2 = <i>Controller Running</i>	the controller is running.																									
3 = <i>Reverse</i>	the controller is commanded to run in the reverse direction.																									
4 = <i>Motor Overload</i>	when a motor overload condition exists.																									
5 = <i>Ramp Regulated</i>	the ramp regulator is modifying the programmed accel/decel times to avoid an overcurrent or overvoltage fault from occurring.																									
6 = <i>Above Frequency</i>	the controller exceeds the frequency value set in P48 – [Output Threshold].																									
7 = <i>Above Current</i>	the controller exceeds the value set in P48 – [Output Threshold]. Important: Value for P48 – [Output Threshold] must be entered in % of controller rated output current.																									
8 = <i>Above DC Bus Voltage</i>	the controller exceeds the DC bus voltage value set in P48 – [Output Threshold].																									
9 = <i>Retries Exhausted</i>	the number of retries for P50 – [Restart Tries] is exceeded.																									

Program Group																						
P#	Parameter Description	Min/Max Range	Units	Factory Default																		
48	<p>[Output Threshold] Determines the on/off point for the TB3 output relay when [P47 – Output Configure] is set to 6, 7, and 8.</p> <table border="1"> <thead> <tr> <th>Settings</th> <th>Ranges</th> </tr> </thead> <tbody> <tr> <td>6</td> <td>0 to 240 Hz</td> </tr> <tr> <td>7</td> <td>0 to 180 %</td> </tr> <tr> <td>8</td> <td>0 to 815 Volts</td> </tr> </tbody> </table>	Settings	Ranges	6	0 to 240 Hz	7	0 to 180 %	8	0 to 815 Volts	0 to 815	Numeric Value	0										
Settings	Ranges																					
6	0 to 240 Hz																					
7	0 to 180 %																					
8	0 to 815 Volts																					
49	<p>[PWM Frequency] Carrier frequency for the PWM output waveform. The chart below provides derating guidelines based on the PWM freq. setting.</p> <table border="1"> <caption>Derating Guidelines Data</caption> <thead> <tr> <th>Carrier Frequency (kHz)</th> <th>% Output Current (A)</th> </tr> </thead> <tbody> <tr><td>1</td><td>100</td></tr> <tr><td>2</td><td>100</td></tr> <tr><td>3</td><td>100</td></tr> <tr><td>4</td><td>100</td></tr> <tr><td>5</td><td>96</td></tr> <tr><td>6</td><td>92</td></tr> <tr><td>7</td><td>88</td></tr> <tr><td>8</td><td>85</td></tr> </tbody> </table> <p>Important: Ignoring derating guidelines can cause reduced controller performance.</p>	Carrier Frequency (kHz)	% Output Current (A)	1	100	2	100	3	100	4	100	5	96	6	92	7	88	8	85	2.0 to 8.0	0.1 kHz	4.0 kHz
Carrier Frequency (kHz)	% Output Current (A)																					
1	100																					
2	100																					
3	100																					
4	100																					
5	96																					
6	92																					
7	88																					
8	85																					
50	<p>[Restart Tries] Maximum number of times the controller will attempt to reset a fault.</p>	0 to 9	Numeric Value	0																		
51	<p>[Restart Time] Time between restart attempts.</p>	0.5 to 300	0.1 Seconds	10.0 Seconds																		
52	<p>[DB Enable] Enables/disables external dynamic braking. Setting "0" = Disable. Settings 1 through 100 = % duty cycle braking. Important: The Rockwell Automation Bulletin 160 DB Resister package is rated for 5% duty cycle. Use of this package above 5% should not be used and voids the UL rating of this device. When setting this parameter to a value above 5% duty cycle the resister must be sized to avoid overheating of the resister package. Important: This parameter cannot be programmed while the controller is running.</p>	0 to 100	Numeric Value	0																		

Program Group

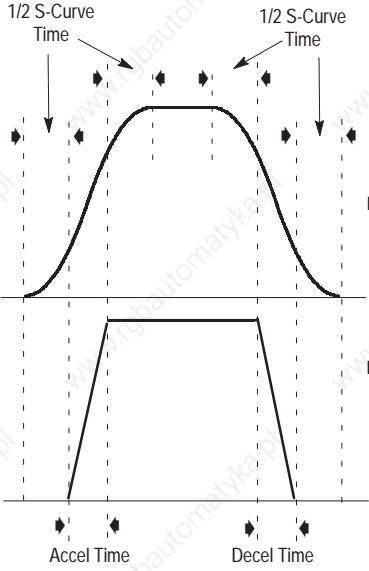
P#	Parameter Description	Min/Max Range	Units	Factory Default
53	<p>[S-Curve] Enables a fixed shape S-Curve. See formula below:</p> <div style="border: 1px solid black; padding: 5px; width: fit-content;"> <p>Formula: S-Curve Time = Accel or Decel Time x "S-Curve" setting (in percent) ^①</p> </div>  <div style="border: 1px solid black; padding: 5px; width: fit-content; margin-top: 10px;"> <p>Example: Accel Time = 10 seconds S-Curve Setting = 3 S-Curve Time = 10 x .3 = 3 Seconds</p> </div> <p>Important: Maximum S-Curve time is 60 seconds.</p> <p>^① See values in the <i>Min/Max Range</i> column</p>	<p>S-Curve Setting</p> <ul style="list-style-type: none"> 0 = 0% 1 = 10% 2 = 20% 3 = 30% 4 = 40% 5 = 50% 6 = 60% 7 = 70% 8 = 80% 9 = 90% 10 = 100% 	Numeric Value	0
54	<p>[Clear Fault] Setting this parameter to a "1" performs a fault reset. When the fault reset function is complete, the value is automatically set back to "0".</p> <p>Important: This parameter cannot be programmed while the controller is running.</p>	0 to 1	Numeric Value	0
55	<p>[Memory Probe Address] Used by Rockwell Automation field service personnel.</p>	Numeric Value	Numeric Value	Numeric Value

Program Group				
P#	Parameter Description	Min/Max Range	Units	Factory Default
56	<p>[Reset Functions] When using this parameter, the controller's parameters and their associated defaults are reset according to the descriptions below:</p> <p>0 = Idle State 1 = Reset defaults (restores all controller parameter settings to factory defaults). 2 = Update input mode (restores the controller to most recent programmed P46 – [Input Mode] setting).</p> <p>After the reset/update function is complete, this parameter will set itself back to a "0". This parameter cannot be programmed while the controller is running. Important: For setting "1" only, an F48 – [Reprogram Fault] will occur and must be cleared by cycling the STOP input to the controller. Important: P46 – [Input Mode] factory defaults to "3 wire" control. If using keypad control, change parameter setting back to a "2" to regain program keypad control.</p>	0 to 2	Numeric Value	0
57	<p>[Program Lock] When set to a "1", this parameter protects all controller parameters from being changed by unauthorized personnel.</p>	0 to 1	Numeric Value	0
58	<p>[Internal Frequency] When P59 – [Frequency Select] is set to a "1" this parameter provides the controller frequency command. This parameter will change the frequency command in "Real time".</p> <p>Important: Follow normal programming procedures. Once the desired command frequency is reached the ENTER key must be pressed to store this value to EEPROM memory. If the ESC key is used before the ENTER key, the frequency will return to the original value following the normal accel/decel curve.</p>	0 to 240	0.1 Hz	60.0 Hz
59	<p>[Frequency Select] Selects the source of the frequency command for the controller.</p> <p>Settings: 0 = external frequency command 1 = internal frequency command from P58 – [Internal Frequency].</p>	0 to 1	Numeric Value	0
60	<p>[Zero Offset] Used to add or subtract any system offset to the analog input. See P16 – [Analog Input] for additional information. Important: This parameter cannot be programmed while the drive is running.</p>	-50.0 to 50.0	Numeric Value	0%

= This parameter applies only to the Analog Signal Follower model.

Program Group

P#	Parameter Description	Min/Max Range	Units	Factory Default
61	[Preset Frequency 0] The programmed value sets the frequency that the controller outputs when selected.	0 to 240	0.1 Hz	3 Hz
62	[Preset Frequency 1] The programmed value sets the frequency that the controller outputs when selected	0 to 240	0.1 Hz	20 Hz
63	[Preset Frequency 2] The programmed value sets the frequency that the controller outputs when selected.	0 to 240	0.1 Hz	30 Hz
64	[Preset Frequency 3] The programmed value sets the frequency that the controller outputs when selected.	0 to 240	0.1 Hz	40 Hz
65	[Preset Frequency 4] The programmed value sets the frequency that the controller outputs when selected.	0 to 240	0.1 Hz	45Hz
66	[Preset Frequency 5] The programmed value sets the frequency that the controller outputs when selected.	0 to 240	0.1 Hz	50 Hz
67	[Preset Frequency 6] The programmed value sets the frequency that the controller outputs when selected.	0 to 240	0.1 Hz	55 Hz
68	[Preset Frequency 7] The programmed value sets the frequency that the controller outputs when selected.	0 to 240	0.1 Hz	60 Hz
69	[Accel Time 2] Time for the controller to ramp from 0.0 Hz. to P33 – [Maximum Frequency] . The rate is linear for any increase in command frequency unless P53 – [S-Curve] is set to a value other than “0”. Setting this to 0.0 sec. gives 0.1 sec acceleration with the initial current limit turned off. This allows quicker acceleration times for low inertia systems. For medium to high inertia systems, the minimum value should be 0.1 sec.	0.0 to 600	0.1 Sec.	20.0 Sec.
70	[Decel Time 2] Time for the controller to ramp from P33 – [Maximum Frequency] to 0.0 Hz. The rate is linear for any decrease in command frequency unless P53 – [S-Curve] is set to a value other than “0”.	0.1 to 600	0.1 Sec.	20.0 Sec.

= This parameter applies only to the Preset Speed model

Preset Accel/Decel Chart For Preset Speed Model Only

TB3-4 (SW3)	TB3-2 (SW2)	TB3-1 (SW1)	Preset	Accel ^①	Decel ^①
0	0	0	Preset 0	P30 – [Accel Time 1]	P31 – [Decel Time 1]
0	0	1	Preset 1		
0	1	0	Preset 2		
0	1	1	Preset 3		
1	0	0	Preset 4	P69 – [Accel Time 2]	P70 – [Decel Time 2]
1	0	1	Preset 5		
1	1	0	Preset 6		
1	1	1	Preset 7		

Refer to Figure 2.4 for the Preset Speed model control wiring diagram.

① When using P46 – **[Input Mode]** setting “4” the Accel and Decel times are selected by providing an input to TB3-8. See page 2-9 for additional information.

Program Group				
P#	Parameter Description	Min/Max Range	Units	Factory Default
71	[IR Compensation] The programmed value adds a voltage to the output based on the torque current. An additional 31 volts (150%) are added to 460 volt units to compensate for stator resistance. 15.5 volts (150%) is added for 230 volt units. If the drive trips on an Overload fault (F7), or has trouble accelerating to commanded speed, this value should be reduced. A setting of 0% disables this function.	0 to 150	1%	50%
72	[Slip Compensation] This parameter compensates for the inherent slip in an induction motor. A frequency is added to the commanded output frequency based on torque current. If motor shaft speed decreases significantly under heavy loads then this value should be increased. A setting of 0.0 Hz disables the function.	0.0 to 5.0	0.1 Hz	2.0 Hz
73	[Reverse Disable] When this parameter is set to a 1, the reverse is disabled. The reverse command may come from the analog input, the TB3-5 input, the keypad, or a serial command. With a negative analog input and reverse disabled, the frequency command will be zero in bipolar mode and minimum frequency in unipolar mode. All digital reverse inputs including two-wire "Run Reverse" will be ignored with reverse disabled. Important: This parameter cannot be programmed while the drive is running.	0 to 1	Numeric value	0
74	[Analog Select] 0 = unipolar analog input 0 to +10V 1 = bipolar analog input -10 to +10V Important: With bipolar analog input selected, the reverse inputs (keypad, terminal block, serial) are ignored. In addition, two-wire "Run Reverse" commands, P75 – [Analog Input Minimum] and P32 – [Minimum Frequency] settings are ignored. Important: This parameter cannot be programmed while the drive is running.	0 to 1	Numeric value	0
75	[Analog Input Minimum] Important: Do not adjust this parameter until setting P60 – [Zero Offset] . Sets the percent of analog input used to represent P32 – [Minimum Frequency] . If the minimum analog input equals minimum frequency no action is needed. If it is desired to adjust the analog input to equal [Minimum Frequency] , use P16 – [Analog Input] to adjust the analog input to the desired level and then enter this value into P75. Analog inversion can be accomplished by setting this value larger than P76. Important: This parameter cannot be programmed while the drive is running.	0.0 to 150.0	0.1%	0.0%
76	[Analog Input Maximum] Important: Do not adjust this parameter until setting P60 – [Zero Offset] . Sets the percent of analog input used to represent P33 – [Maximum Frequency] . If the maximum analog input equals maximum frequency no action is needed. If it is desired to adjust the analog input to equal [Maximum Frequency] , use P16 – [Analog Input] to adjust the analog input to the desired level and then enter this value into P76. Analog inversion can be accomplished by setting this value smaller than P75. Important: This parameter cannot be programmed while the drive is running.	0.0 to 150.0	0.1%	100.0%
78	[Compensation] Some drive/motor combinations have inherent instabilities which are exhibited as non-sinusoidal motor currents. A setting of 1 will enable this parameter and attempt to correct this condition. A setting of 0 disables this function. Important: Available in FRN 6.XX and later.	0 to 1	Numeric value	0

//// = This parameter applies only to the Analog Signal Follower model.

Fault Information

Figure 6.1 – Fault Display

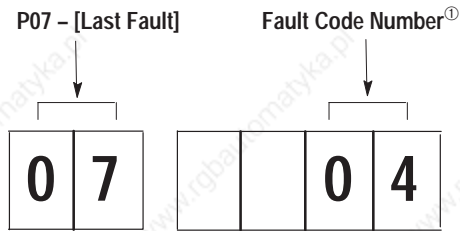

① See Table 6.A below for fault descriptions.

Controllers equipped with a program keypad module will flash the display when a fault is present. If a fault occurs, parameter **07** – [**Last Fault**] displays. You can cross reference the number that appears on the display (e.g., **04**) with the fault numbers listed in Table 6.A.

Fault LED – (Without Program Keypad Module)

Controllers without a program keypad module come equipped with a fault LED. When the fault LED illuminates, a fault condition exists.

Tips To Clear a Fault

Important: If a fault occurs, it is important to address and correct the fault as well as the condition that caused the fault.

To clear a fault, perform one of the following:

- Press the program keypad’s stop button.
- Cycle power to the controller.
- Cycle the input signal at TB3-8 to the controller.
- Set **P54** – [**Clear Fault**] parameter to a “1”.

Table 6.A – Bulletin 160 Fault Descriptions

Fault Number	Fault Indication	Fault Description	Corrective Action
03	Power Loss Fault	DC Bus voltage remains below 85% nominal on power up for longer than 5 seconds.	Monitor incoming AC line for low voltage or line power interruption.
04	Under Voltage Fault	DC Bus voltage fell below the minimum. For controllers rated at input voltage 200 – 240V AC, undervoltage trip occurs at 210V DC bus voltage (equivalent to 150V AC incoming line voltage). For controllers rated at input voltage 380 – 460V AC, undervoltage trip occurs at 390V DC bus voltage (equivalent to 275V AC incoming line voltage).	Monitor incoming AC line for low voltage or line power interruption.
05	Over Voltage Fault	DC Bus maximum voltage exceeded. For controllers rated at input voltage 200 – 240V AC, overvoltage trip occurs at 410V DC bus voltage (equivalent to 290V AC incoming line voltage). For controllers rated at input voltage 380 – 460V AC, overvoltage trip occurs at 815V DC bus voltage (equivalent to 575V AC incoming line voltage).	Bus overvoltage caused by motor regeneration. Monitor incoming AC line for excessive voltage. Extend the decel time or install dynamic brake module or external capacitor module. See Appendix A.

Table 6.A – Bulletin 160 Fault Descriptions (continued)

Fault Number	Fault Indication	Fault Description	Corrective Action
06	Motor Stall Fault	Motor has stalled. Motor load is excessive.	Longer acceleration time or a reduced load required.
07	Motor Overload Fault	Internal electronic overload trip. Excessive motor load exists.	Reduce motor load until controller output current does not exceed the current set by P42 – [Motor Overload Current]. Reduce P38 – [Boost Select].
08	Over Temperature Fault	Excessive heat detected.	Clear blocked or dirty heat sink fins. Check ambient temperature. Check for blocked or non-operating fan.
11	Operator Fault	Keypad has been removed while controller is powered.	Clear fault. Do not remove keypad under power.
12	Overcurrent Fault	Overcurrent detected in hardware trip circuit.	Check short circuit at the controller output or excessive load conditions at the motor.
32	EEPROM Fault	EEPROM has invalid data.	Reset EEPROM using P56 – [Reset Functions]. Set to 1. Cycle power.
33	Max Retries Fault	Controller failed to reset fault within the number of retries set in P50 – [Restart Tries].	Repair system fault.
38	Phase U Fault	Phase to ground fault detected between controller and motor in phase U.	Check the wiring between the controller and motor. Check motor for grounded phase.
39	Phase V Fault	Phase to ground fault detected between controller and motor in phase V.	Check the wiring between the controller and motor. Check motor for grounded phase.
40	Phase W Fault	Phase to ground fault detected between controller and motor in phase W.	Check the wiring between the controller and motor. Check motor for grounded phase.
41	UV Short Fault	Excessive current has been detected between these two controller output terminals.	Check the motor and external wiring to the controller output terminals for a shorted condition.
42	UW Short Fault	Excessive current has been detected between these two controller output terminals.	Check the motor and external wiring to the controller output terminals for a shorted condition.
43	VW Short Fault	Excessive current has been detected between these two controller output terminals.	Check the motor and external wiring to the controller output terminals for a shorted condition.
48	Reprogram Fault	Occurs when controller parameters are reset to defaults.	Clear fault.
49	Zero Overload Fault	Occurs when load requires excessive current at zero hertz, or P38 – [Boost Volts] set too high.	Reduce motor load at zero hertz. Reduce motor dwell time at zero hertz. Reduce P38 – [Boost Volts].

Table 6.B – Troubleshooting

Problem	Corrective Action
Motor does not start (No output voltage to motor).	<ol style="list-style-type: none"> 1. Check power circuit. <ul style="list-style-type: none"> • Check supply voltage. • Check all fuses and disconnects. 2. Check motor. <ul style="list-style-type: none"> • Verify that motor is connected properly. 3. Check control input signals. <ul style="list-style-type: none"> • Verify that START signal is present. • Verify that STOP signal is present. • Verify that RUN FORWARD and RUN REVERSE signals are NOT both active. 4. Check P46 – [Input Mode]. <ul style="list-style-type: none"> • If P46 – [Input Mode] is set to "2", only the program keypad module Start button will start the motor.
Controller Started but motor NOT rotating. (P01 – [Output Frequency] displays "0.0").	<ol style="list-style-type: none"> 1. Check motor. <ul style="list-style-type: none"> • Verify that motor is connected properly. 2. Check frequency source P06 – [Frequency Command]. <ul style="list-style-type: none"> • Verify that frequency signal is present at terminal block TB3. • -10- +10V signal • 4-20mA signal • Verify that Preset Frequencies are set properly. 3. Check control input signals. <ul style="list-style-type: none"> • Verify that SW1, SW2 and SW3 are correct. (Refer to the chart at the end of Chapter 5). 4. Check parameter settings. <ul style="list-style-type: none"> • Verify that P59 – [Frequency Select] is showing desired frequency source. • Verify that P58 – [Internal Frequency] is the desired value.
Motor not accelerating properly.	<ol style="list-style-type: none"> 1. Check motor. <ul style="list-style-type: none"> • Verify that motor is connected properly. • Verify that no mechanical problems exist. 2. Check parameter settings. <ul style="list-style-type: none"> • Verify that P30 – [Accel Time 1] or P69 – [Accel Time 2] is set properly. • Verify that P43 – [Current Limit] is set properly. • Verify that P38 – [Boost Volts] is set properly.
Can not operate in "RUN FWD/ RUN REV" mode.	<ol style="list-style-type: none"> 1. Verify that P46 – [Input Mode] is set to "1". 2. Verify that P73 – [Reverse Disable] or P74 – [Analog Select] are not set to "1". 3. Verify that power has been cycled for above change to take effect. 4. Verify that both RUN FORWARD and RUN REVERSE switches are NOT closed simultaneously.

Block Diagram of Bulletin 160 Analog Signal Follower

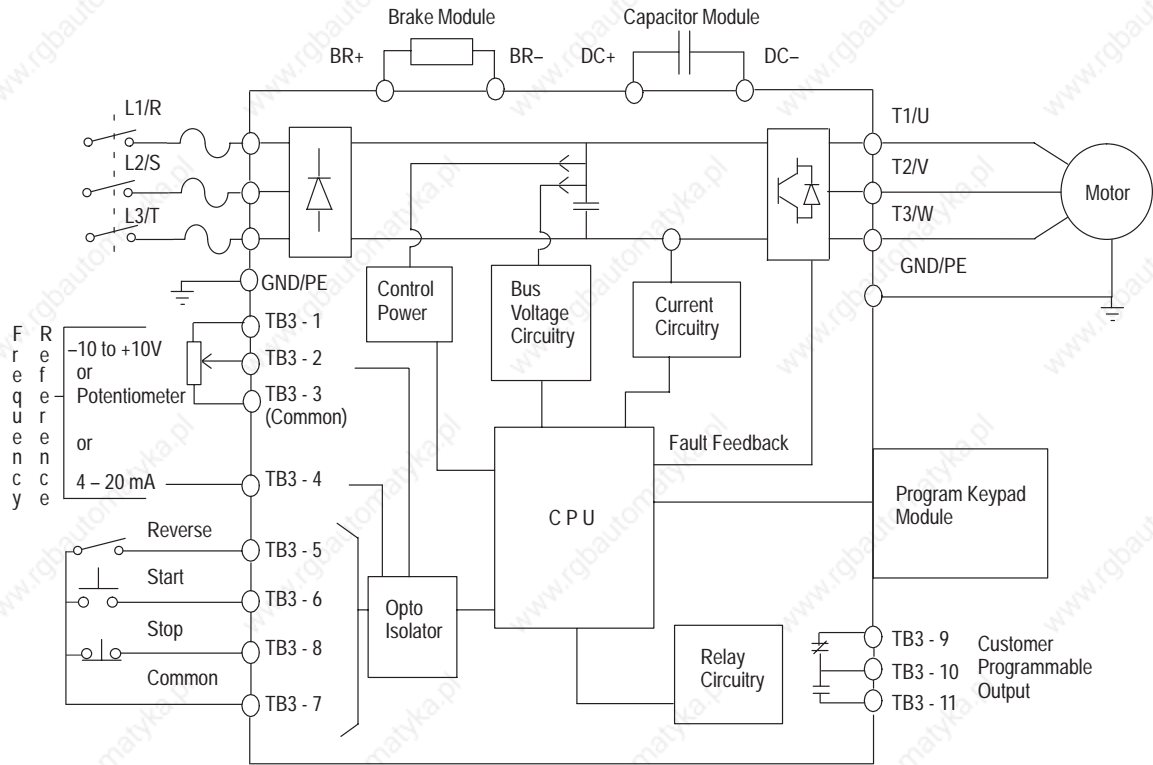

Controller Specifications

Table A.1 and Table A.2 contain information that is unique to each SSC™ Controller rating. Table A.3 contains information that applies to all Controller ratings.

Table A.1 – Specifications for Controllers Rated 200 – 240V Single and Three Phase Input



	<i>Controller Catalog Number</i>				
Single Phase (input)	160S-AA02	160S-AA03	160S-AA04	160S-AA08	
Three Phase (input)	160-AA02	160-AA03	160-AA04	160-AA08	160-AA12
Output Ratings					
3 Phase Motor Rating kW (HP)	0.37 (1/2)	0.55 (3/4)	0.75 (1)	1.5 (2)	2.2 (3)
Output Current (A) Max	2.3	3.0	4.5	8.0	12.0
Power Dissipation (Watts)	20	25	40	70	105
Input Ratings					
Input Voltage, Frequency	200/240V Single Phase and Three Phase, 50/60 Hz				
Operational Range (V)	180 – 265V				
Input kVA	1.1	1.4	2.2	3.7	5.7
Environmental Specifications					
Cooling Method	Convection Cooled		Fan Cooled		
AC Dynamic Braking Torque ^①					
With external Dynamic Brake Module (%)	300	233	200	150	115
Without external Dynamic Brake Module (%)	100	100	100	50	50

Table A.2 – Specifications for Controllers Rated 380 – 460V Three Phase Input

	<i>Controller Catalog Number</i>				
Three Phase (input)	160-BA01	160-BA02	160-BA03	160-BA04	160-BA06
Output Ratings					
3 Phase Motor Rating kW (HP)	0.37 (1/2)	0.55 (3/4)	0.75 (1)	1.5 (2)	2.2 (3)
Output Current (A) Max	1.2	1.7	2.3	4.0	6.0
Power Dissipation (Watts)	25	30	40	65	80
Input Ratings					
Input Voltage, Frequency	380/460V Three Phase, 50/60 Hz				
Operational Range (V)	340 – 506V				
Input kVA	1.1	1.6	2.2	3.7	5.7
Environmental Specifications					
Cooling Method	Convection Cooled		Fan Cooled		
AC Dynamic Braking Torque ^①					
With external Dynamic Brake Module (%)	300	233	200	150	115
Without external Dynamic Brake Module (%)	100	100	100	50	50

① Estimated. Actual value depends on motor characteristics.

Table A.3 – Specifications For All Controller Ratings

Input/Output Ratings (All Controller Ratings)	
Output Voltage (V)	Adjustable from 0V to input voltage
Output Frequency (Hz)	0 to 240 Hertz Programmable
Efficiency (%)	97.5% (Typical)
Transient Protection	Standard 2 kV (Optional 6 kV using MOV module). See accessories on page A-5.
Environmental Specifications (All Controller Ratings)	
Enclosure	IP 20
Ambient Temperature	0°C to 50°C
Storage Temperature	-40°C to 85°C
Relative Humidity	0 to 95% (non condensing)
Vibration	1.0 G Operational – 2.5 G Non-operational
Shock	15 G Operational – 30 G Non-operational
Altitude	1,000 m (3,300 ft.) without derating
Control Inputs (All Controller Ratings)	
Control Input Type	For dry contact closure input – the controller has an internal 12V power supply that provides 10mA (typical) current flow. Also accepts open collector/solid state inputs (sinking) with maximum leakage current of 50 µA. Optional 24V DC interface allows use of 24V DC sinking inputs. See page A-4 for ordering information.
Start, Stop, Forward/Reverse	Configurable inputs for 2 or 3 wire control
SW1, SW2, SW3 (Preset Speed Model only)	Configurable Inputs for control of 8 preset speeds and 2 Accel/Decel times
Programmable Input	TB3-8 can be configured to select: Accel/Decel Times Controller Enable/Disable Local/Remote
Approvals and Standards Compliance (All Controller Ratings)	
Approvals	 UL508C  CSA 22.2 
Designed to meet these standards	IEC 146-1-1 FCC Class A ^① and B ^① VDE 0871 ^① and 0875 ^①
Control Inputs (Analog Signal Follower only – All Controller Ratings)	
External Speed Potentiometer	1K to 10K Ohms, 2 Watts Minimum
Analog Input (4 to 20mA)	Input Impedance 250 Ohms
Analog Input (-10 to +10V DC)	Input Impedance 100K Ohms
Control Output (All Controller Ratings)	
Programmable Output (Form C Relay contact)	Resistive rating: 0.4A @125V AC, 0.2A @ 230V AC, 2A @ 30V DC Inductive rating: 0.2A @ 125V AC, 0.1A @ 230V AC, 1A @30V DC

^① With external components.

Table A.3 – Specifications For All Controller Ratings (continued)

Control Features (All Controller Ratings)	
PWM Algorithm	Sine Weighted PWM with Harmonic Compensation
Switching Device (3-Phase Output)	IGBT (Intelligent Power Module)
V/Hz Ratio	Programmable
Carrier Frequency	Adjustable from 2 kHz to 8 kHz in 100 Hz Increments (Factory default is 4 kHz)
DC Boost	Adjustable – Select from a family of Boost Curves
Current Limiting	Trip Free Operation, Co-ordinated for Controller and Motor Protection – Programmable from 1% to 180% of Controller Output Current
Motor Protection	I ² t Overload Protection – 150% for 60 seconds, 200% for 30 seconds
Overload Pattern #0	Flat response over speed range (no speed compensation)
Overload Pattern #1	Speed compensation below 25% of Base Speed
Overload Pattern #2	Speed compensation below 100% of Base Speed
Acceleration/Deceleration Time(s)	0.1 to 600 Seconds
S-Curve Accel/Decel Time(s)	0 to 100% of Accel/Decel time – not to exceed 60 seconds
Stopping Modes	3 modes (programmable)
Ramp to stop	0.1 to 600 seconds
Coast to stop	Stops all PWM Output
DC Injection Braking	Applies DC Voltage to the Motor for 0 to 25 seconds
Protective Features (All Controller Ratings)	
Overcurrent	200% hardware limit, 300% instantaneous fault
Excessive Temperature	Embedded temperature sensor trips if heatsink temperature exceeds 95°C
Over/Under Voltage	DC Bus voltage is monitored for safe operation. For controllers rated at input voltage 200 – 240V AC, overvoltage trip occurs at 410V DC bus voltage (equivalent to 290V AC incoming line voltage). For controllers rated at input voltage 380 – 460V AC, overvoltage trip occurs at 815V DC bus voltage (equivalent to 575V AC incoming line voltage). For controllers rated at input voltage 200 – 240V AC, undervoltage trip occurs at 210V DC bus voltage (equivalent to 150V AC incoming line voltage). For controllers rated at input voltage 380 – 460V AC, undervoltage trip occurs at 390V DC bus voltage (equivalent to 275V AC incoming line voltage).
Control Ride Through	Minimum ride through is 0.5 seconds – typical value 2 seconds
Ground Short	Any output phase to ground, detected at run
Faultless Ride Through	100 Milliseconds
Output Short Circuit	Any output phase to phase short
Programming (All Controller Ratings)	
Programmer	Optional, Removable Program Keypad Module
Type of Display	6 character LED – two digit parameter number and four digit value
Local Controls	SPEED, RUN, STOP, and DIRECTION controls

Accessories

For All Controller Ratings – 0.37 to 2.2kW (1/2 to 3 HP)								
Controller Ratings			Dynamic Brake Module	MOV Module	3% Line Reactors Open Style ^①	Line Filters		Capacitor Module
Input Voltage Rating	HP	kW	Cat. No.	Cat. No.	Cat. No.	Cat. No. ^②	Cat. No. ^③	Cat. No.
200 – 240V 50/60Hz 1 Phase	1/2	0.37	160-BMA1	160-MMA1	–	160S-LFA1	160S-RFA-6-A	160-CMA1
	3/4	0.55	160-BMA1	160-MMA1	–	160S-LFA1	160S-RFA-6-A	160-CMA1
	1	0.75	160-BMA1	160-MMA1	–	160S-LFA1	160S-RFA-10-A	160-CMA1
	2	1.5	160-BMA2	160-MMA1	–	160S-LFA1	160S-RFA-16-A	④
200 – 230V 50/60Hz 3 Phase	1/2	0.37	160-BMA1	160-MMA1	1321-3R4-B	160-LFA1	160-RFB-3-A	160-CMA1
	3/4	0.55	160-BMA1	160-MMA1	1321-3R4-A	160-LFA1	160-RFB-3-A	160-CMA1
	1	0.75	160-BMA1	160-MMA1	1321-3R4-A	160-LFA1	160-RFB-9-A	160-CMA1
	2	1.5	160-BMA2	160-MMA1	1321-3R8-A	160-LFA1	160-RFB-9-A	160-CMA1
	3	2.2	160-BMA2	160-MMA1	1321-3R12-A	160-LFA2	–	160-CMA1
380 – 460V 50/60Hz 3 Phase	1/2	0.37	160-BMB1	160-MMB1	1321-3R2-B	160-LFB1	160-RFB-3-A	160-CMB1
	3/4	0.55	160-BMB1	160-MMB1	1321-3R2-A	160-LFB1	160-RFB-3-A	160-CMB1
	1	0.75	160-BMB1	160-MMB1	1321-3R2-A	160-LFB1	160-RFB-3-A	160-CMB1
	2	1.5	160-BMB2	160-MMB1	1321-3R4-B	160-LFB1	160-RFB-9-A	160-CMB1
	3	2.2	160-BMB2	160-MMB1	1321-3R8-B	160-LFB1	160-RFB-9-A	160-CMB1

Replacement Parts and Accessories

Fan ^⑤ Replacement Kit	Ready/Fault Panel	Program Keypad Module	DeviceNet Communication Module
Cat. No.	Cat. No.	Cat. No.	Cat. No.
160-FRK1	160-B1	160-P1	160-DN1

Drive Model	24V DC Interface ^⑥
	Cat. No.
Analog	160-DM-SF1
Preset	160-DM-PS1

- ① Catalog numbers listed are for 3% impedance open style units. NEMA 1 and 5% impedance reactor types are also available, refer to Publication 1321-2.0 for detailed information.
- ② The 160-LF type filters are designed to meet Class A conducted emissions. These units have been tested with a maximum motor cable length of 75m (250 ft.) for 230V units and 40m (133 ft.) for 460V units.
- ③ The 160-RF type filters are designed to meet Class A and B conducted emissions. These units have been tested with a maximum motor cable length of 25m (80 ft.) for both 230V and 460V units.
- ④ Included with controller.
- ⑤ The MTBF for the fan is 40,000 hours at 50° C.
- ⑥ Allows 24V DC sinking inputs.

Figure A.1 – Controller Dimensions

Controllers Rated 200 – 240V Single Phase

Overall Dimensions	160S AA02	160S AA03	160S AA04	160S AA08 ^①
H mm (inches)	152 (6.00)	152 (6.00)	152 (6.00)	152 (6.00)
W mm (inches)	72 (2.83)	72 (2.83)	72 (2.83)	72 (2.83)
D mm (inches)	136 (5.4)	136 (5.4)	136 (5.4)	136 (5.4)
Weight Kg. (lbs.)	0.8 (1.76)	0.8 (1.76)	0.9 (1.98)	0.9 (1.98)

Controllers Rated 200 – 240V 3 Phase

Overall Dimensions	160 AA02	160 AA03	160 AA04	160 AA08	160 AA12
H mm (inches)	152 (6.00)	152 (6.00)	152 (6.00)	152 (6.00)	152 (6.00)
W mm (inches)	72 (2.83)	72 (2.83)	72 (2.83)	72 (2.83)	130 (5.12)
D mm (inches)	136 (5.4)	136 (5.4)	136 (5.4)	136 (5.4)	136 (5.4)
Weight Kg. (lbs.)	0.8 (1.76)	0.8 (1.76)	0.9 (1.98)	0.9 (1.98)	1.1 (2.46)

Controllers Rated 380 – 460V 3 Phase

Overall Dimensions	160 BA01	160 BA02	160 BA03	160 BA04	160 BA06
H mm (inches)	152 (6.00)	152 (6.00)	152 (6.00)	152 (6.00)	152 (6.00)
W mm (inches)	72 (2.83)	72 (2.83)	72 (2.83)	72 (2.83)	130 (5.12)
D mm (inches)	136 (5.4)	136 (5.4)	136 (5.4)	136 (5.4)	136 (5.4)
Weight Kg. (lbs.)	0.8 (1.76)	0.8 (1.76)	0.8 (1.98)	0.9 (1.98)	1.1 (2.46)

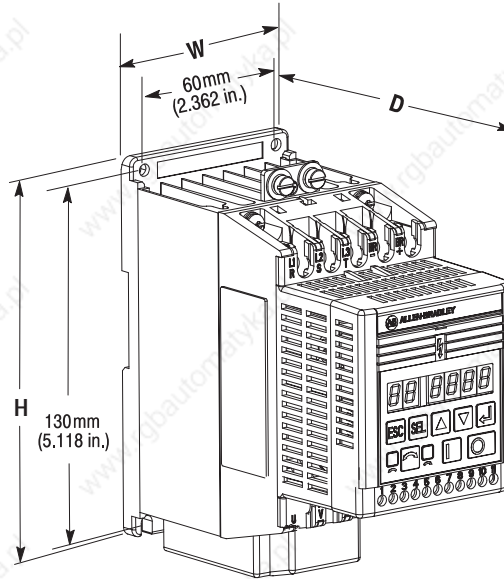

^① External capacitor modules are provided with this model and mount separately.

Use the drilling template at the back of the manual for mounting the controller.

Figure A.2 – Mounting Requirements

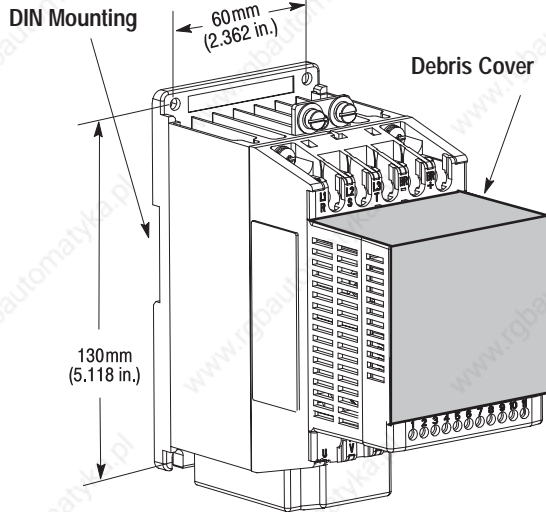

Dimensions	Metric	English
Min. Panel Thickness (14 GA)	19mm	0.0747 in.
Mounting Base Screws	m4 x 0.7	# 8 – 32
Mounting Torque	1.13 to 1.56 Nm	10 – 14 lb. in.

- See Figure A.1 for details on controller dimensions and weights.
- There must be a minimum of 12.5mm (0.5 inches) clearance around all sides of the controller. Use either DIN rail or mounting holes. (Use the drilling template at the back of the manual for mounting the controller.)
- Leave debris cover attached during controller installation to protect from falling debris. To ensure proper controller operation, remove cover before applying power.

Approximate Dimensions

Dimensions are shown in millimeters (inches). Dimensions are not to be used for manufacturing purposes.

Figure A.3 – Dynamic Brake Module – Both Sizes

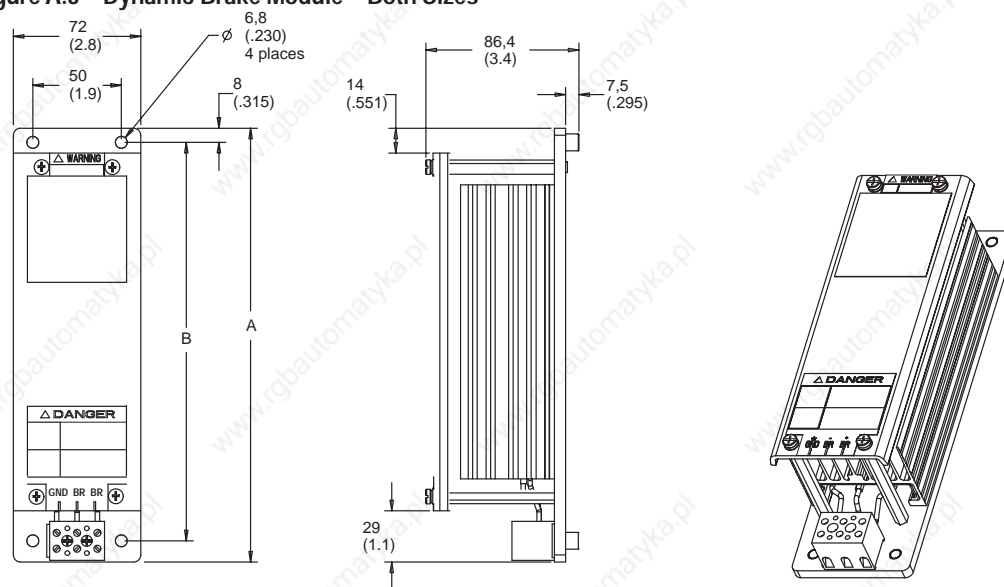

Cat. No.	A	B
160-BMA1 & 160-BMB1	245 (9.64)	225 (8.86)
160-BMA2 & 160-BMB2	334 (13.15)	314 (12.36)

Approximate Dimensions, Continued

Dimensions are shown in millimeters (inches). Dimensions are not to be used for manufacturing purposes.

Figure A.4 – MOV Module

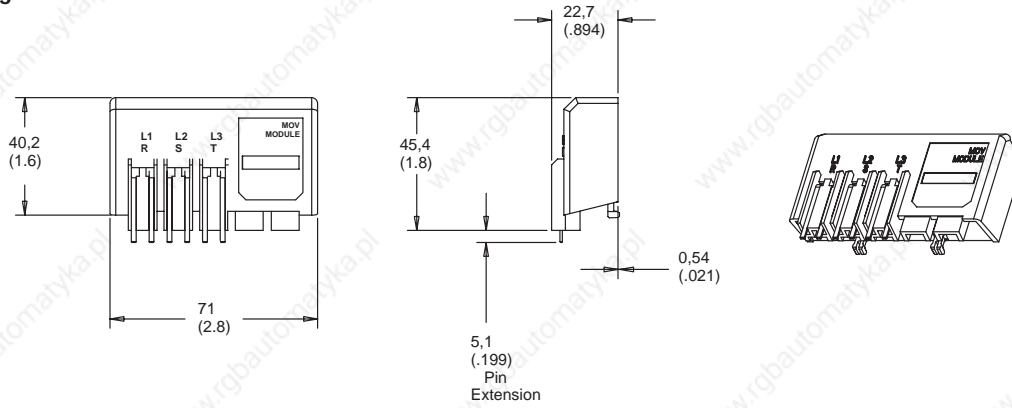
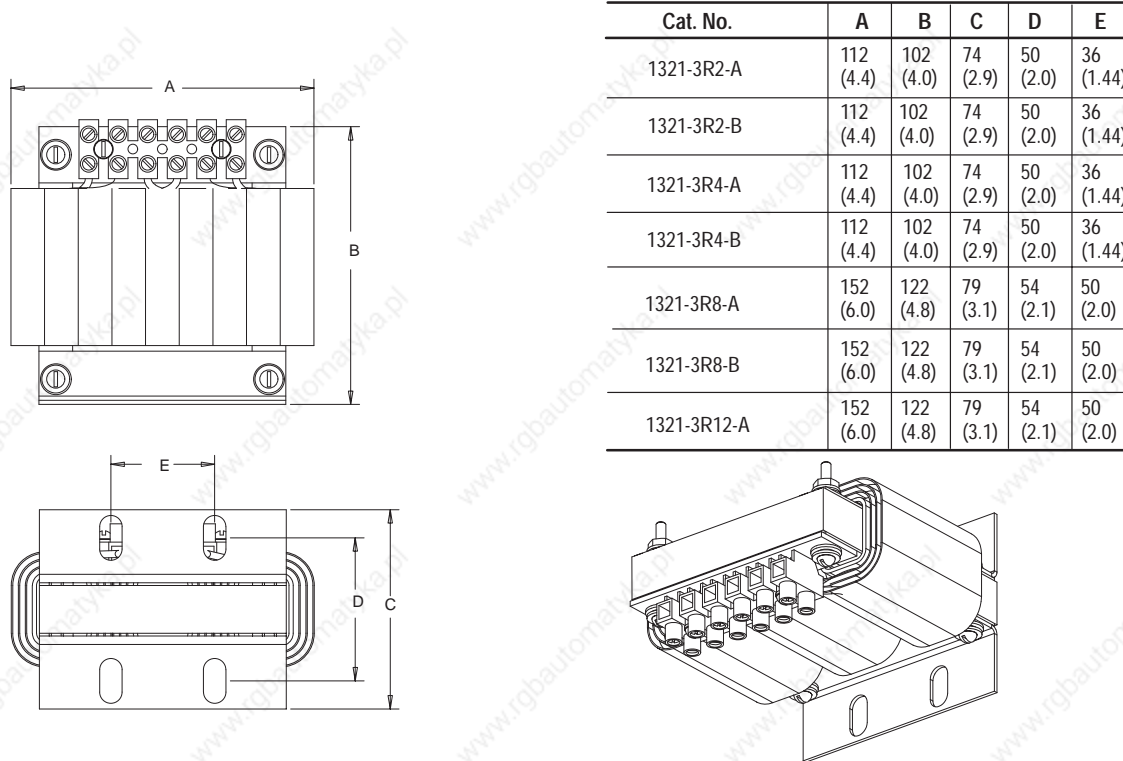

Figure A.5 – Line Reactor



Cat. No.	A	B	C	D	E
1321-3R2-A	112 (4.4)	102 (4.0)	74 (2.9)	50 (2.0)	36 (1.44)
1321-3R2-B	112 (4.4)	102 (4.0)	74 (2.9)	50 (2.0)	36 (1.44)
1321-3R4-A	112 (4.4)	102 (4.0)	74 (2.9)	50 (2.0)	36 (1.44)
1321-3R4-B	112 (4.4)	102 (4.0)	74 (2.9)	50 (2.0)	36 (1.44)
1321-3R8-A	152 (6.0)	122 (4.8)	79 (3.1)	54 (2.1)	50 (2.0)
1321-3R8-B	152 (6.0)	122 (4.8)	79 (3.1)	54 (2.1)	50 (2.0)
1321-3R12-A	152 (6.0)	122 (4.8)	79 (3.1)	54 (2.1)	50 (2.0)

Approximate Dimensions, Continued

Dimensions are shown in millimeters (inches). Dimensions are not to be used for manufacturing purposes.

Figure A.6 – Line Filters

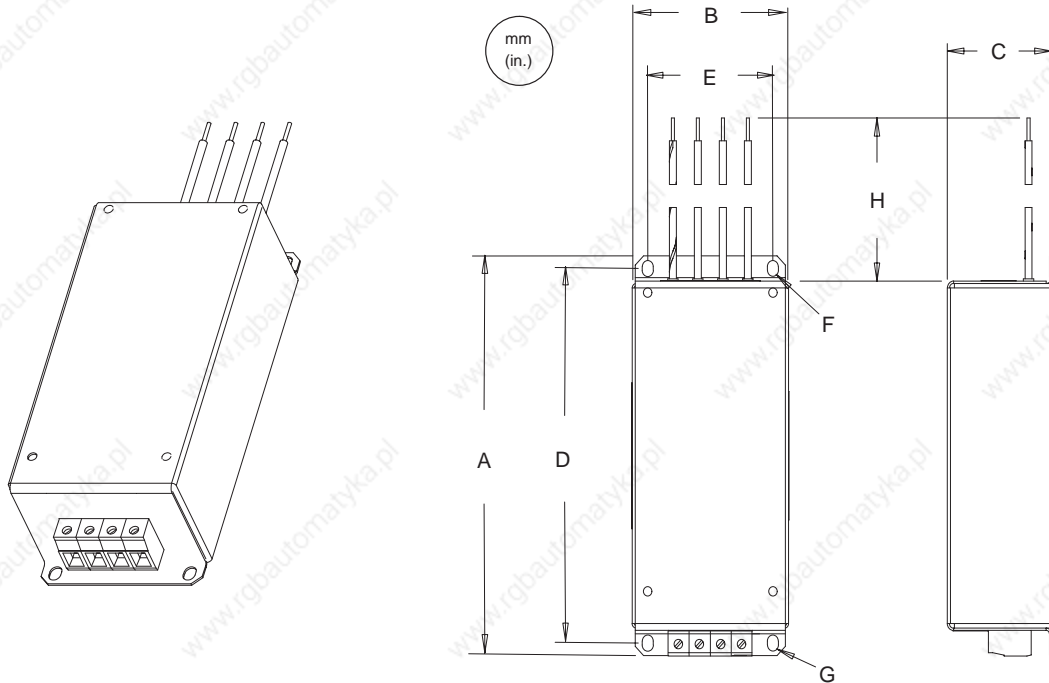

Line Filter Module	A	B	C	D	E	F	G	H
160S-RFA-6-A 160S-RFA-10-A 160S-RFA-16-A	182.0 (7.17)	75.0 (2.95)	30.0 (1.18)	167.0 (6.57)	60.0 (2.36)	6.5 x 4.5 (0.26 x 0.18) hole dim. (2 places)	4.2 (0.17) dia. hole (2 places)	200 (7.87)
160-RFB-3-A	182.0 (7.17)	75.0 (2.95)	35.0 (1.38)	167.0 (6.57)	60.0 (2.36)			
160-RFB-9-A	182.0 (7.17)	75.0 (2.95)	47.5 (1.87)	167.0 (6.57)	60.0 (2.36)			
160-LF (All Types)	174.0 (6.85)	75.0 (2.95)	50.0 (1.97)	163.0 (6.41)	60.0 (2.36)	6.9 x 5.25 (0.272 x 0.207) hole dim.	6.9 x 5.25 (0.272 x 0.207) hole dim.	200 (7.87)

Approximate Dimensions, Continued

Dimensions are shown in millimeters (inches). Dimensions are not to be used for manufacturing purposes.

Figure A.7 – Capacitor Module

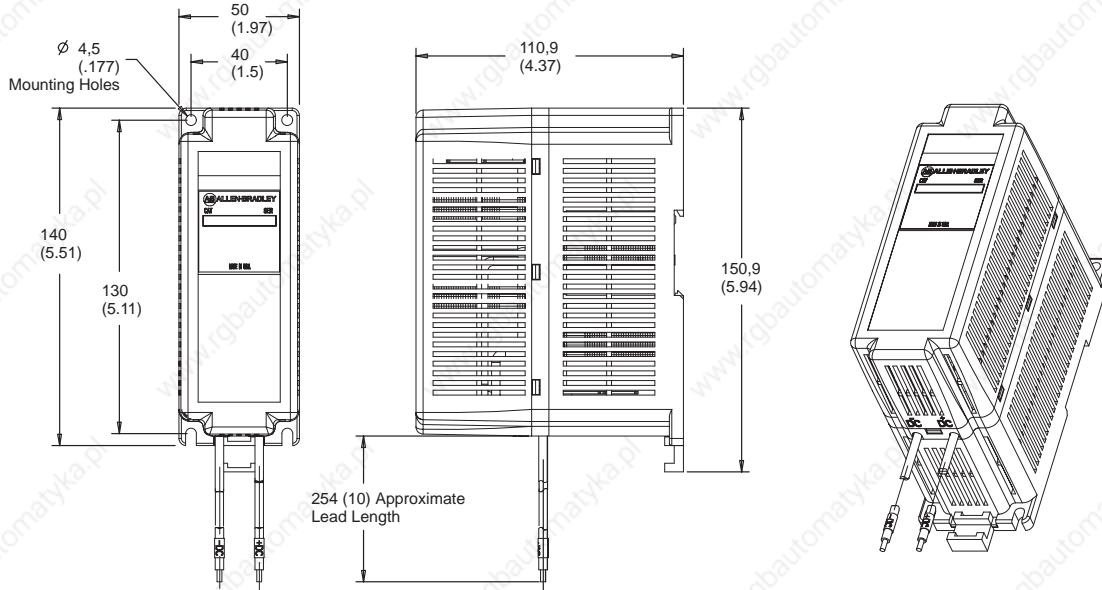

Approximate Dimensions, Continued

Dimensions are shown in millimeters (inches). Dimensions are not to be used for manufacturing purposes.

Figure A.8 – DeviceNet Module Attached to Controller

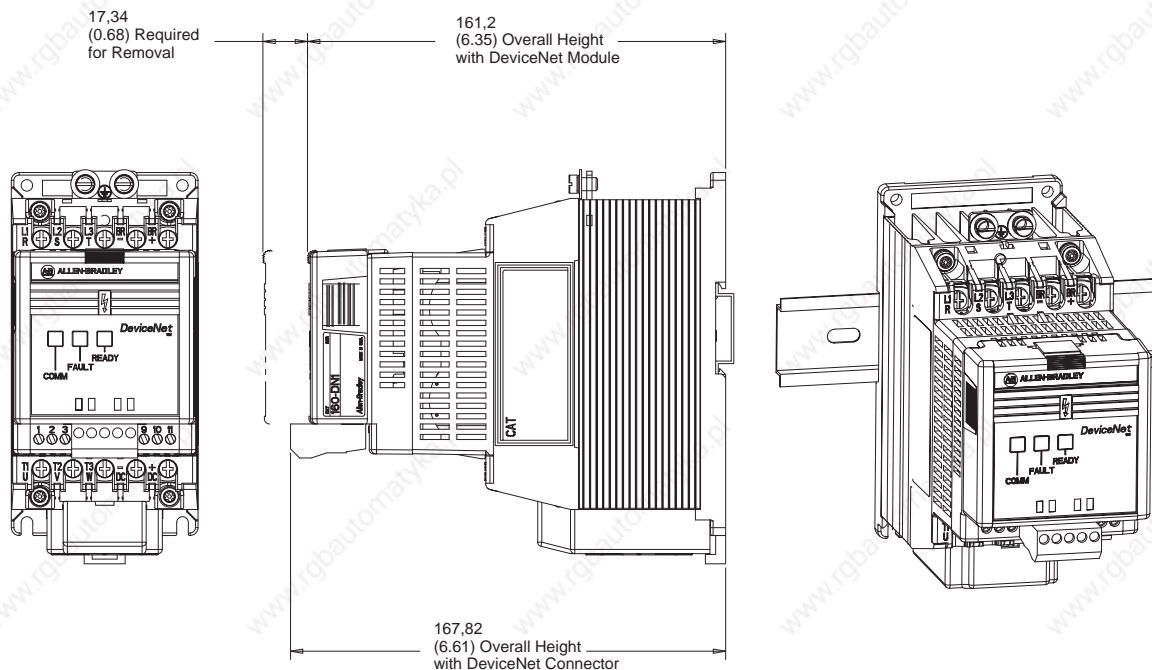
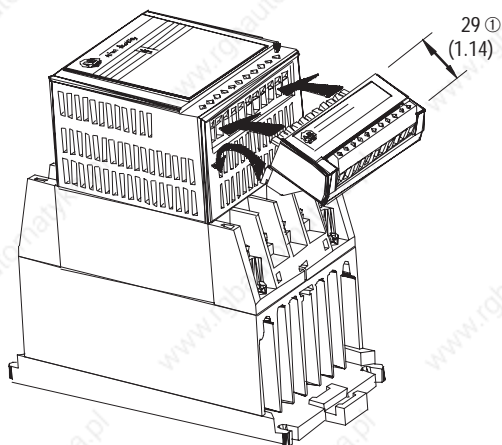

Figure A.9 – 24V DC Interface Module



① This device does not effect the overall height of the drive.

CE Compliance

This controller is a component intended for implementation in machines or systems for the industrial environment. It has been tested to meet the Council Directive 89/336 Electromagnetic Compatibility (EMC) and all applicable standards.

Important: The conformity of the controller and filter to any standard does not guarantee that the entire installation will conform. Many other factors can influence the total installation and only direct measurements can verify total conformity. It is therefore the responsibility of the machine manufacturer, to ensure, that the conformity is met.

A copy of the Declaration of Conformity (DOC) is available from your local Rockwell Automation sales office.

Essential Requirements for a Conforming EMC Installation

1. An input line filter module (see “Accessories” in Appendix A) must be installed to reduce conducted emissions.
“LF type” Filters – These units have been tested with a maximum motor cable length of 75 meters (250 feet) for controllers rated 200 – 240V AC, and 40 meters (130 feet) for controllers rated 380 – 460V AC.
“RF type” Filters – These units have been tested with a maximum motor cable length of 25 meters (80 feet) for all ratings.
2. The controller system must be mounted in a shielded enclosure to reduce radiated emissions.
3. Grounding of equipment and cable shields must be solid, with low impedance connections.
4. Motor and control cables entering the shielded enclosure must have EMC-tested shielded cable clamps, or grounded metal conduit.
5. All motor cables must use shielded cable, or be in grounded metal conduit.
6. All control and signal wiring must use shielded cable or be in grounded metal conduit.
7. The Common terminals (TB3-3 & 7) must have a solid connection to PE (protective earth).

General Instructions for an EMC Compliant Installation

Refer to Figure B.1.

Shielded Enclosure

- Typical NEMA or IEC metal enclosures are adequate.
- The ground connection of the shielded enclosure must be solidly connected to the PE terminal of the controller. Good conductivity must be assured – grounding must provide a low impedance path to high frequency signals.
- All wiring, except input power leads, must use shielded cable.
- Input power, output power and control wiring inside the enclosure must be physically separated.

- Input power, output power and control wiring outside the enclosure must use separate shielded cables, or separate conduit.

Cable Clamps

- Use suitable EMC-tested cable clamps only.
- The connection area must be 360 degrees around the shielded cable.
- The cable clamps also provide strain-relief for the cable.
- When using conduit, the contact point of metal entry connections must be free of paint or non-conductive surfaces and solidly connected with good conductivity to the enclosure.

Figure B.1 – Recommended Grounding Configuration

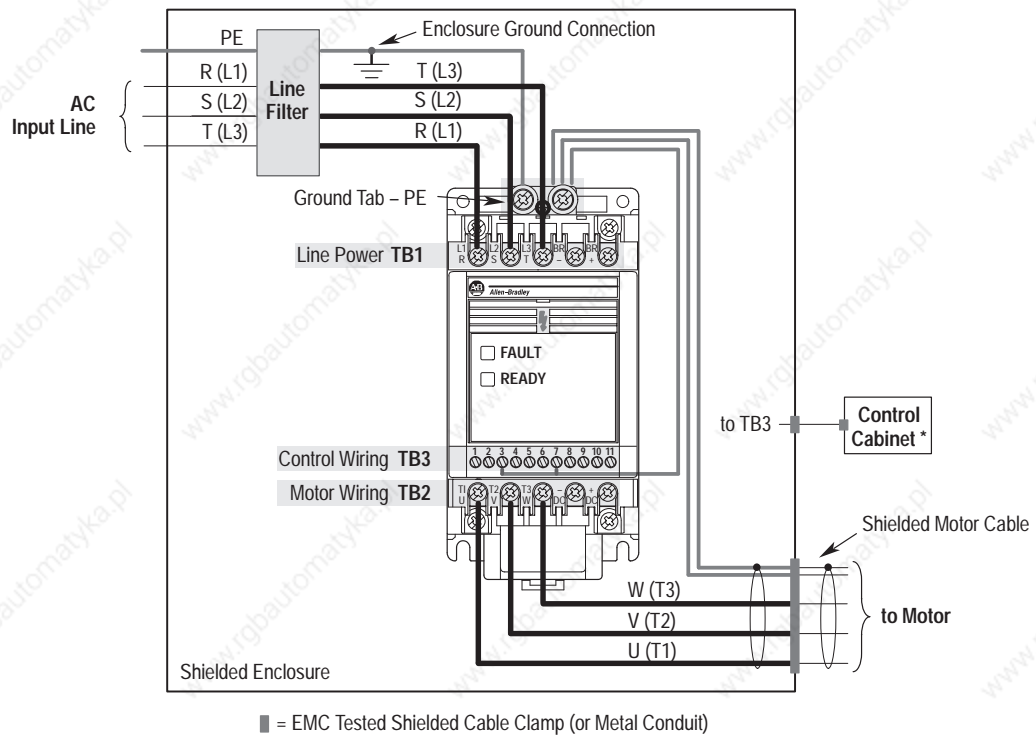

Motor Cable

- The cable between the controller and motor must be a 4-wire shielded cable (three phases and ground). Refer to Figure B.2 and Figure B.3.
- Do not exceed the maximum motor cable length for the specific line filter module used.
- Inside the shielded enclosure, shielded motor cable must be used as close to the controller’s output terminals as possible. The shield must be solidly connected to the PE terminal of the controller.
- Where the shielded motor cable exits the enclosure, an EMC-tested cable clamp, or metal conduit must be used to solidly connect the cable shield to the enclosure.
- The shield on the motor side must be solidly connected to the motor housing with an EMC-tested cable clamp, or conduit, providing good conductivity from the cable shield to the motor housing.

Figure B.2 – Motor Connections

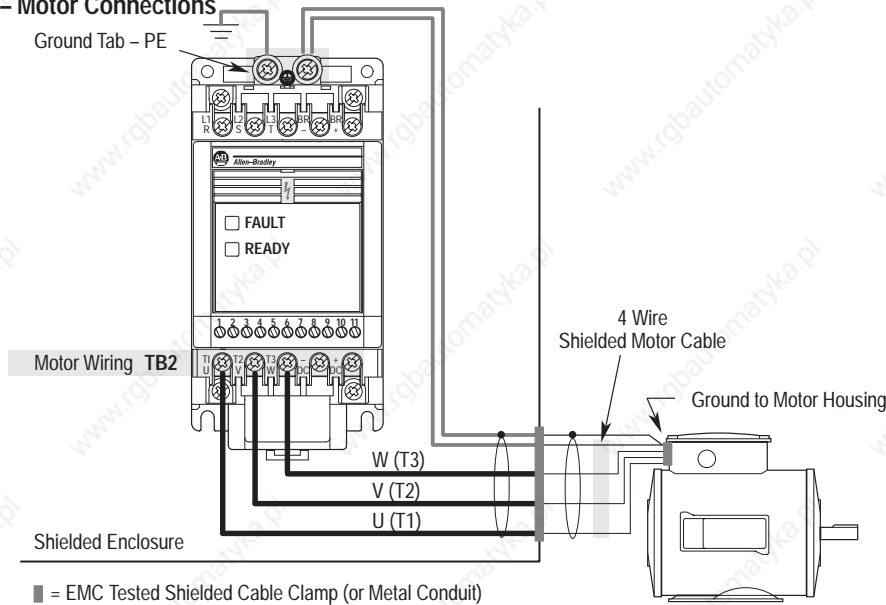

Figure B.3 – Shielded Motor and Control Cable Example



Control Cable

- Control wiring must use shielded cable, or grounded metal conduit. Refer to Figure B.3 and Figure B.4.
- The shield must be connected to signal common at both ends of the cable.
- The Common terminals (TB3-3 & 7) must be solidly connected (and as short as possible) to the PE terminal of the controller.

Figure B.4 – Control Connections

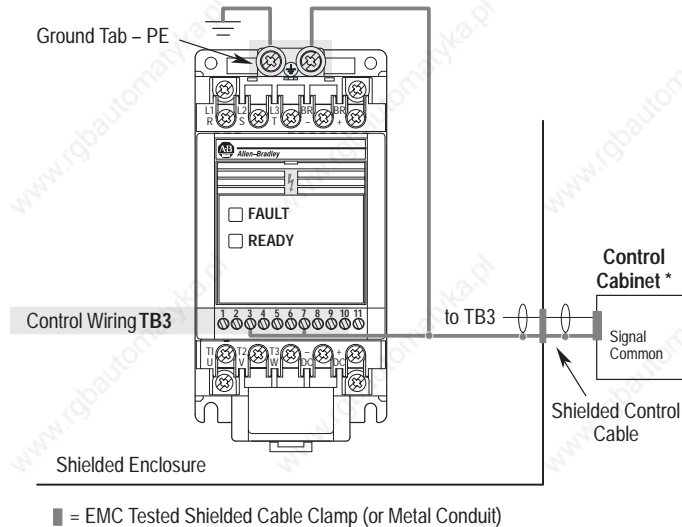

* When the control circuitry is located outside of the 160 enclosure.

Low Voltage Directive 73/23/EEC Compliance

This product complies with Low Voltage Directive 73/23/EEC when conforming with the following installation requirements:

- Review the General Precautions section on page 1-1, inside front cover, and other ATTENTION statements throughout this manual prior to installation of the controller.

- The controller is intended to be installed with a fixed connection to the earth. The use of residual-current-operated protective devices (RCDs) or ground fault indicators is not recommended. If unavoidable, the Bulletin 160 is compatible with type B RCDs only.
- The controller should be installed in an appropriate or suitable enclosure.

Important: The conformity of this controller and filter to any standard does not guarantee that the entire installation will conform. Many factors can influence the total installation and only direct measurements can verify total conformity.

Numbers

24V DC interface, A-10
 50 Hz dipswitch, 3-2
 60 Hz dipswitch, 3-2

A

AC input wiring, 2-2
 accel/decel control, 5-4, 5-11
 accessories, A-4
 ambient temperature, A-2
 analog input, 2-6, 2-7
 analog scaling
 analog input, 5-3
 zero offset, 5-10
 analog input maximum, 5-12
 analog input minimum, 5-12
 analog select, 5-12
 approvals, A-2
 auto restart
 restart time, 5-8
 restart tries, 5-8

B

block diagram, 6-4
 branch circuit disconnect, 2-2, 2-3

C

cable length recommendations
 capacitive current, 2-5
 reflected wave, 2-4
 capacitive current, cable length recommendations, 2-5
 capacitor module, A-9
 connecting, 2-2
 carrier frequency, pwm, 5-8, A-3
 catalog number description, 1-2
 CE, 2-1, A-2, B-1
 changing base frequency, from factory default, 3-2
 clearing faults, 5-9, 6-1
 compensation, 5-12
 control wiring
 Analog Signal Follower model, 2-6
 Preset Speed model, 2-6
 control wiring requirements
 Analog Signal Follower model, 2-6, 2-7
 Preset Speed model, 2-6, 2-7
 controller features, 2-1
 controller specifications, A-1
 conventions used in this manual, 1-2
 CSA, A-2
 CUL, A-2

current limiting, 5-6
 current rating, A-1

D

DB enable, 5-8
 DC brake to stop, 5-4, 5-6
 DC hold level, 5-6
 defaults, resetting to, 5-10
 determining drive information, 1-2
 DeviceNet module, A-10
 diagnostics, 5-2, 5-3, 6-2, 6-3
 dimensions, A-5
 display group, 5-2, 5-3
 display group parameters, 5-2, 5-3
 display mode, 3-1
 dynamic brake, connection, 2-2
 dynamic brake module, A-6

E

electrostatic discharge, 1-1, 3-2
 EMC
 control connections, B-4
 grounding configuration, B-2
 installation, B-1
 motor connections, B-3
 shielded motor and control cable example, B-3

F

fan/pump volts/hz patterns, 5-5
 fault buffer, 5-2
 fault information, troubleshooting, 6-1
 fault LED, 6-1
 faults, clearing, 5-9, 6-1
 frequency dipswitch, 3-2
 frequency source selection
 Analog Signal Follower model, 2-6, 2-7, 5-10
 Preset Speed Model, 2-6, 2-7, 5-11

G

general precautions, 1-1
 grounding, 2-6

I

input mode selection, 2-8, 5-7
 input power conditioning, 2-2

L

line filters, A-4, A-8
 line reactor, A-4, A-8
 line side protection, 2-3

low voltage directive compliance, B-4

M

min/max frequency, 5-4
minimum clearance, 2-1
motor cable lengths, effects, 2-4
motor cable recommendations, 2-4
mounting requirements, 2-1, A-5
MOV module, A-4, A-7

N

nameplate information, 1-2

O

operating controller
 with program keypad module, 2-1, 3-1
 without program keypad module, 2-1
output contacts, 2-7, 5-7
output ratings, A-1
overload protection, 2-2, 5-6

P

parameters
 display group, 5-2
 overview, 5-1
 program group, 5-4
potentiometer wiring, 2-6
power, wiring, 2-2
precautions, 1-1
preset frequencies, 2-7, 5-11
program group, parameters, 5-4
program keypad module
 description, 3-1
 display mode, 3-1
 features, 3-1
 installation, 3-2
 key descriptions, 3-1
 program mode, 3-1
 removal, 3-2
program lock, 5-10
program mode, 3-1

I-2

programming, 3-1, 5-1

R

reflected wave, cable length recommendations, 2-4
replacement parts, A-4
resetting, to factory defaults, 5-10
reverse, 2-6, 3-1
RWR (reflected wave reducer), 2-4, 2-5

S

S-curve, 5-9
skip frequency, 5-5
specifications, A-1, A-2, A-3
standards compliance, A-2
start, 2-7, 2-8, 2-9, 3-1
start-up, 4-1
stopping, 2-7, 2-8, 2-9, 3-1, 5-4
storage temperature, 2-1, A-2

T

terminal blocks
 specifications, 2-2, 2-6
 TB1, 2-1, 2-2
 TB2, 2-1, 2-2
 TB3, 2-1, 2-2, 2-7
torque ratings, A-1
troubleshooting, 6-3
 fault descriptions, 6-1

V

vibration, A-2
voltage rating, A-1

W

wiring
 control and signal, 2-6, 2-7, 2-8, 2-9
 input line fuses, 2-3
 motor cable recommendations, 2-4
 terminal blocks specifications, 2-2, 2-6
 wire size recommendations, 2-2, 2-6



Allen-Bradley

Rockwell Automation helps its customers receive a superior return on their investment by bringing together leading brands in industrial automation, creating a broad spectrum of easy-to-integrate products. These are supported by local technical resources available worldwide, a global network of system solutions providers, and the advanced technology resources of Rockwell.

Worldwide representation.



Argentina • Australia • Austria • Bahrain • Belgium • Bolivia • Brazil • Bulgaria • Canada • Chile • China, People's Republic of • Colombia • Costa Rica • Croatia • Cyprus • Czech Republic • Denmark • Dominican Republic • Ecuador • Egypt • El Salvador • Finland • France • Germany • Ghana • Greece • Guatemala • Honduras • Hong Kong • Hungary • Iceland • India • Indonesia • Iran • Ireland • Israel • Italy • Jamaica • Japan • Jordan • Korea • Kuwait • Lebanon • Macau • Malaysia • Malta • Mexico • Morocco • The Netherlands • New Zealand • Nigeria • Norway • Oman • Pakistan • Panama • Peru • Philippines • Poland • Portugal • Puerto Rico • Qatar • Romania • Russia • Saudi Arabia • Singapore • Slovakia • Slovenia • South Africa, Republic of • Spain • Sweden • Switzerland • Taiwan • Thailand • Trinidad • Tunisia • Turkey • United Arab Emirates • United Kingdom • United States • Uruguay • Venezuela

Rockwell Automation Headquarters, 1201 South Second Street, Milwaukee, WI 53204 USA, Tel: (1) 414 382-2000

Fax: (1) 414 382-4444

Publication 0160-5.9 – May 1998

40055-180-01(01)

Supersedes Publications 0160-5.9 – December 1996, 0160-5.9DU2 – May 1997, 0160-5.9DU4 – January 1998

Copyright 1996 Allen-Bradley Company, Inc., a Rockwell International company