

SIMATIC

S7-400, M7-400 Programmable Controllers Module Specifications

Reference Manual

This manual is part of the documentation
package with the order number:
6ES7498-8AA03-8BA0

Edition 09/2003

A5E00069467-07

| | |
|--|-----------|
| Preface, Contents | 1 |
| General Technical Specifications | 2 |
| Racks | 3 |
| Power Supply Modules | 4 |
| Digital Modules | 5 |
| Analog Modules | 6 |
| Interface Modules | 7 |
| IM 463-2 | 8 |
| PROFIBUS DP Master Interface IM 467/IM 467 FO | 9 |
| Cable Duct and Fan Subassemblies | 10 |
| RS 485 Repeater | 11 |
| CPUs for M7-400 | 12 |
| M7-400 Expansions | 13 |
| Interface Submodules | |
| Appendices | |
| Parameter Sets for Signal Modules | A |
| Diagnostic Data of the Signal Modules | B |
| Spare Parts and Accessories | C |
| Guidelines for Handling Electro- static Sensitive Devices (ESD) | D |
| List of Abbreviations | E |
| Glossary, Index | |

Safety Guidelines

This manual contains notices intended to ensure personal safety, as well as to protect the products and connected equipment against damage. These notices are highlighted by the symbols shown below and graded according to severity by the following texts:



Danger

indicates that death, severe personal injury or substantial property damage will result if proper precautions are not taken.



Warning

indicates that death, severe personal injury or substantial property damage can result if proper precautions are not taken.



Caution

indicates that minor personal injury can result if proper precautions are not taken.

Caution

indicates that property damage can result if proper precautions are not taken.

Notice

draws your attention to particularly important information on the product, handling the product, or to a particular part of the documentation.

Qualified Personnel

Only **qualified personnel** should be allowed to install and work on this equipment. Qualified persons are defined as persons who are authorized to commission, to ground and to tag circuits, equipment, and systems in accordance with established safety practices and standards.

Correct Usage

Note the following:



Warning

This device and its components may only be used for the applications described in the catalog or the technical description, and only in connection with devices or components from other manufacturers which have been approved or recommended by Siemens.

This product can only function correctly and safely if it is transported, stored, set up, and installed correctly, and operated and maintained as recommended.

Trademarks

SIMATIC®, SIMATIC HMI® and SIMATIC NET® are registered trademarks of SIEMENS AG.

Third parties using for their own purposes any other names in this document which refer to trademarks might infringe upon the rights of the trademark owners.

Copyright © Siemens AG 1999-2003 All rights reserved Disclaim of Liability

The reproduction, transmission or use of this document or its contents is not permitted without express written authority. Offenders will be liable for damages. All rights, including rights created by patent grant or registration of a utility model or design, are reserved.

Siemens AG
Bereich Automation and Drives
Geschäftsgebiet Industrial Automation Systems
Postfach 4848, D- 90327 Nuernberg

We have checked the contents of this manual for agreement with the hardware and software described. Since deviations cannot be precluded entirely, we cannot guarantee full agreement. However, the data in this manual are reviewed regularly and any necessary corrections included in subsequent editions. Suggestions for improvement are welcomed.

© Siemens AG 1999-2003
Technical data subject to change.

Preface

Purpose of the Manual

The manual contains reference information on operator actions, descriptions of functions and technical specifications of the central processing units, power supply modules and interface modules of the S7-400.

How to configure, assemble and wire these modules in an S7-400 or M7-400 system is described in the installation manuals for each system.

Required Basic Knowledge

You will need a general knowledge of automation to understand this manual.

In addition, you are required to know how to use computers or devices with similar functions (e. g. programming devices) under Windows 95/98/2000 or NT operating systems. Since S7-400 is configured with the STEP 7 basic software, you have to have a good working knowledge of the software. You can acquire this knowledge in the manual "Programming with STEP 7". Read the notes on the safety of electronic controllers in the appendix of the Installation manual – especially when using a S7-400 in safety-relevant areas.

Target Group

This manual is aimed at people with the required qualifications to commission, operate and maintain the products described.

Where is this Manual valid?

The manual is valid for the S7-400, M7-400 programmable controller.

Changes Compared to the Previous Version

Since the previous version of the “Module Specifications” reference manual, the following changes have been made:

- The descriptions of the CPU and the CPU relevant products and topics have been put together in one manual, “CPU Specifications”.
- The descriptions of the H CPUs and their associated products and topics have been moved to the manual “**S7–400 H Programmable Controller, Redundant Systems**”

Note: The previous version of this “Module Specifications” reference manual can be recognized by the number in the footer: A5E00069467-06.

The current number is: A5E00069467-07.

Certification

The SIMATIC S7-400 product range has the following certificates:

- Underwriters Laboratories, Inc.: UL 508 (Industrial Control Equipment)
- Canadian Standards Association: CSA C22.2 Nummer 142 (Process Control Equipment)
- Factory Mutual Research: Approval Standard Class Number 3611.

You can find details on the certificates and approvals in the reference manual “Module Specifications”.

CE Labeling

The SIMATIC S7-400 product range complies with the requirements and protection objectives of the following EU directives:

- EC low voltage directive 73/23/EEC
- EC electromagnetic compatibility directive 89/336/EEC

C-Tick Mark

The SIMATIC S7-400 product range complies with the requirements of the AS/NZS 2064 standard (Australia and New Zealand).

Standards

The SIMATIC S7-400 product range complies with the requirements and criteria of the IEC 61131-2.

Place of this Documentation in the Information Environment

This manual forms part of the S7-400 and M7-400 documentation.

| System | Documentation Package |
|---------------|---|
| S7-400/M7-400 | <ul style="list-style-type: none">• <i>S7-400, M7-400 Programmable Controllers; Hardware and Installation</i>• <i>S7-400, M7-400 Programmable Controllers; Module Specifications</i>• <i>Automation System S7-400 CPU Data</i>• <i>S7-400 Instruction List</i> |

Finding Your Way

To help you find special information quickly, the manual contains the following access aids:

- At the start of the manual you will find a complete table of contents and a list of the diagrams and tables that appear in the manual.
- An overview of the contents of each section is provided in the left column on each page of each chapter.
- You will find a glossary in the appendix at the end of the manual. The glossary contains definitions of the main technical terms used in the manual.
- At the end of the manual you will find a comprehensive index which gives you rapid access to the information you need.

Specific Information for S7-400

You require the following manuals and manual packages in order to program and commission an S7-400:

| Manual/ Manual Package | Contents |
|--|--|
| <p><i>Standard Software for S7 and M7</i> STEP 7 Basic Information</p> | <ul style="list-style-type: none"> • Installing and starting up STEP 7 on a programming device / PC • Working with STEP 7 with the following contents: <ul style="list-style-type: none"> Managing projects and files Configuring and assigning parameters to the S7-400 configuration Assigning symbolic names for user programs Creating and testing a user program in STL/LAD Creating data blocks Configuring the communication between two or more CPUs Loading, storing and deleting user programs in the CPU / programming device Monitoring and controlling user programs Monitoring and controlling the CPU • Guide for efficiently implementing the programming task with the programming device / PC and STEP 7 • How the CPUs work (for example, memory concept, access to inputs and outputs, addressing, blocks, data management) • Description of STEP 7 data management • Using data types of STEP 7 • Using linear and structured programming • Using block call instructions • Using the debug and diagnostic functions of the CPUs in the user program (for example, error OBs, status word) |
| <p>STEP 7 Reference Information <i>Statement List (STL) for S7-300 and S7-400</i> <i>Ladder Logic (LAD) for S7-300 and S7-400</i> <i>Function Block Diagram (FBD) for S7-300 and S7-400</i> <i>System and Standard Functions</i></p> | <ul style="list-style-type: none"> • Basic procedure for working with STL, LAD, or FBD (for example, structure of STL, LAD, or FBD, number formats, syntax) • Description of all instructions in STEP 7 (with program examples) • Description of the various addressing methods in STEP 7 (with examples) • Description of all functions integrated in the CPUs • Description of the internal registers in the CPU • Description of all system functions integrated in the CPUs • Description of all organization blocks integrated in the CPUs |
| <p>Manual <i>PG 7xx</i></p> | <ul style="list-style-type: none"> • Description of the programming device hardware • Connecting a programming device to various devices • Starting up a programming device |

Specific Information for M7-400

This documentation package describes the hardware of the M7-400. You will need the following additional documentation for programming and starting up an M7-400:

| Documentation | Contents | Order No. |
|---|--|--------------------|
| System Software for M7-300/400 Program Design Programming Manual | Designing, writing and testing a C program for M7 CPU/FM modules with the M7 SYS programming package, using the M7 SYS functions | 6ES7802-0FA14-0BA0 |
| System Software for M7-300/400 System and Standard Functions Reference Manual | Detailed description of the M7 SYS functions and data structures, listing of messages types | |
| System Software for M7-300/400 Installation and Operation User Manual | Installing and configuring the operating system and system software | |

Recycling and Disposal

The S7-400 is environmentally friendly and can thus be recycled. Consult a certified disposal agency for electronics junk to recycle and dispose of your old equipment in an environmentally friendly manner.

Further Support

If you have any technical questions, please get in touch with your Siemens representative or agent responsible.

<http://www.siemens.com/automation/partner>

Training Centers

Siemens offers a number of training courses to familiarize you with the SIMATIC S7 automation system. Please contact your regional training center or our central training center in D 90327 Nuremberg, Germany for details:

Telephone: +49 (911) 895-3200.

Internet: <http://www.sitrain.com>

A&D Technical Support

Worldwide, available 24 hours a day:



| | | |
|---|--|---|
| <p>Worldwide (Nuernberg) Technical Support</p> <p>24 hours a day, 365 days a year Phone: +49 (180) 5050-222 Fax: +49 (180) 5050-223 E-Mail: adsupport@siemens.com GMT: +1:00</p> | | |
| <p>Europe / Africa (Nuernberg) Authorization</p> <p>Local time: Mon.-Fri. 8:00 AM to 5:00 PM Phone: +49 (180) 5050-222 Fax: +49 (180) 5050-223 E-Mail: adsupport@siemens.com GMT: +1:00</p> | <p>United States (Johnson City) Technical Support and Authorization</p> <p>Local time: Mon.-Fri. 8:00 AM to 5:00 PM Phone: +1 (423) 262 2522 Fax: +1 (423) 262 2289 E-Mail: simatic.hotline@sea.siemens.com GMT: -5:00</p> | <p>Asia / Australia (Beijing) Technical Support and Authorization</p> <p>Local time: Mon.-Fri. 8:00 AM to 5:00 PM Phone: +86 10 64 75 75 75 Fax: +86 10 64 74 74 74 E-Mail: adsupport.asia@siemens.com GMT: +8:00</p> |
| <p>The languages of the SIMATIC Hotlines and the authorization hotline are generally German and English.</p> | | |

Service & Support on the Internet

In addition to our documentation, we offer our Know-how online on the internet at:

<http://www.siemens.com/automation/service&support>

where you will find the following:

- The newsletter, which constantly provides you with up-to-date information on your products.
- The right documents via our Search function in Service & Support.
- A forum, where users and experts from all over the world exchange their experiences.
- Your local representative for Automation & Drives via our representatives database.
- Information on field service, repairs, spare parts and more under “Services”.

Contents

| | | |
|----------|--|------------|
| 1 | General Technical Specifications | 1-1 |
| 1.1 | Standards and Approvals | 1-2 |
| 1.2 | Electromagnetic Compatibility | 1-9 |
| 1.3 | Shipping and Storage Conditions for Modules and Backup Batteries | 1-12 |
| 1.4 | Mechanical and Ambient Climatic Conditions for Operating the S7-400/M7-400 | 1-14 |
| 1.5 | Information on Insulation Tests, Protection Class and Degree of Protection | 1-18 |
| 1.6 | Using S7-400 in a zone 2 explosion–risk area | 1-19 |
| 2 | Racks | 2-1 |
| 2.1 | Function and Structure of the Racks | 2-2 |
| 2.2 | The Racks UR1; (6ES7400-1TA01-0AA0) and UR2; (6ES7400-1JA01-0AA0) | 2-3 |
| 2.3 | The Rack UR2-H; (6ES7400-2JA00-0AA0) | 2-5 |
| 2.4 | The Rack CR2; (6ES7401-2TA01-0AA0) | 2-7 |
| 2.5 | The Rack CR3; (6ES7401-2TA01-0AA0) | 2-8 |
| 2.6 | The Racks ER1; (6ES7403-1TA01-0AA0) and ER2; (6ES7403-1JA01-0AA0) | 2-9 |
| 3 | Power Supply Modules | 3-1 |
| 3.1 | Common Characteristics of the Power Supply Modules | 3-2 |
| 3.2 | Redundant Power Supply Modules | 3-4 |
| 3.3 | Backup Battery (Option) | 3-6 |
| 3.4 | Controls and Indicators | 3-8 |
| 3.5 | Fault/Error Messages via LEDs | 3-13 |
| 3.6 | Power Supply Module PS 407 4A; (6ES7407-0DA00-0AA0) | 3-19 |
| 3.7 | Power Supply Module PS 407 4A; (6ES7407-0DA01-0AA0) | 3-21 |
| 3.8 | Power Supply Modules PS 407 10A; (6ES7407-0KA01-0AA0) and PS 407 10A R; (6ES7407-0KR00-0AA0) | 3-23 |
| 3.9 | Power Supply Module PS 407 20A; (6ES7407-0RA00-0AA0) | 3-26 |
| 3.10 | Power Supply Module PS 407 20A; (6ES7407-0RA01-0AA0) | 3-28 |
| 3.11 | Power Supply Module PS 405 4A; (6ES7405-0DA00-0AA0) | 3-30 |

| | | |
|----------|--|------------|
| 3.12 | Power Supply Module PS 405 4A; (6ES7405-0DA01-0AA0) | 3-32 |
| 3.13 | Power Supply Module PS 405 10A; (6ES7405-0KA00-0AA0) | 3-34 |
| 3.14 | Power Supply Modules PS 405 10A; (6ES7405-0KA01-0AA0) and PS 405 10A R; (405-0KR00-0AA0) | 3-36 |
| 3.15 | Power Supply Module PS 405 20A; (6ES7405-0RA00-0AA0) | 3-38 |
| 3.16 | Power Supply Module PS 405 20A; (6ES7405-0RA01-0AA0) | 3-40 |
| 4 | Digital Modules | 4-1 |
| 4.1 | Module Overview | 4-3 |
| 4.2 | Sequence of Steps from Choosing to Commissioning the Digital Module | 4-5 |
| 4.3 | Digital Module Parameter Assignment | 4-6 |
| 4.3.1 | Parameters of the Digital Input Modules | 4-7 |
| 4.3.2 | Parameters of the Digital Output Modules | 4-8 |
| 4.4 | Diagnostics of the Digital Modules | 4-9 |
| 4.5 | Interrupts of the Digital Modules | 4-13 |
| 4.6 | Input Characteristic Curve for Digital Inputs | 4-15 |
| 4.7 | Digital Input Module SM 421; DI 32 × 24 VDC (6ES7421-1BL00-0AA0) | 4-17 |
| 4.8 | Digital Input Module SM 421; DI 32 × 24 VDC; (6ES7421-1BL01-0AA0) | 4-20 |
| 4.9 | Digital Input Module SM 421; DI 16 × 24 VDC; (6ES7421-7BH00-0AB0) | 4-23 |
| 4.9.1 | Assigning Parameters to the SM 421; DI 16 × 24 VDC | 4-27 |
| 4.9.2 | Behavior of the SM 421; DI 16 × 24 VDC | 4-29 |
| 4.10 | Digital Input Module SM 421; DI 16 × 24 VDC; (6ES7421-7BH00-0AB0) | 4-32 |
| 4.10.1 | Assigning Parameters to the SM 421; DI 16 × 24 VDC | 4-36 |
| 4.10.2 | Behavior of the SM 421; DI 16 24 VDC | 4-38 |
| 4.11 | Digital Input Module SM 421; DI 16 × 120 VAC; (6ES7421-5EH00-0AA0) | 4-41 |
| 4.12 | Digital Input Module SM 421; DI 16 × 24/60 VUC; (6ES7 421-7DH00-0AB0) | 4-44 |
| 4.12.1 | Assigning Parameters to the SM 421; DI 16 × 24/60 VUC | 4-47 |
| 4.13 | Digital Input Module SM 421; DI 16 × 120/230 VUC; (6ES7 421-1FH00-0AA0) | 4-50 |
| 4.14 | Digital Input Module SM 421; DI 16 × 120/230 VUC; (6ES7421-1FH20-0AA0) | 4-53 |
| 4.15 | Digital Input Module SM 421; DI 32 × 120 VUC; (6ES7421-1EL00-0AA0) | 4-56 |
| 4.16 | Digital Output Module SM 422; DO 16 × 24 VDC/2 A; (6ES7422-1BH10-0AA0) | 4-59 |

| | | |
|----------|---|------------|
| 4.17 | Digital Output Module SM 422; DO 16 × 24 VDC/2 A; (6ES7422-1BH11-0AA0) | 4-62 |
| 4.18 | Digital Output Module SM 422; DO 16 × 0-125 VDC/1.5 A; (6ES7422-5EH10-0AB0) | 4-65 |
| 4.18.1 | Assigning Parameters to the SM 422; DO 16 × 20-125 VDC/1.5 A | 4-69 |
| 4.19 | Digital Output Module SM 422; DO 32 × 24 VDC/0.5 A; (6ES7422-1BL00-0AA0) | 4-70 |
| 4.20 | Digital Output Module SM 422; DO 32 × 24 VDC/0.5 A; (6ES7422-7BL00-0AB0) | 4-73 |
| 4.20.1 | Assigning Parameters to the SM 422; DO 32 × 24 VDC/0.5 A | 4-77 |
| 4.20.2 | Behavior of the SM 422; DO 32 × 24 VDC/0.5 A | 4-78 |
| 4.21 | Digital Output Module SM 422; DO 8 × 120/230 VAC/5 A; (6ES7422-1FF00-0AA0) | 4-79 |
| 4.22 | Digital Output Module SM 422; DO 16 × 120/230 VAC/2 A; (6ES7422-1FH00-0AA0) | 4-83 |
| 4.23 | Digital Output Module SM 422; DO 16 × 20-120 VAC/2 A; (6ES7422-5EH00-0AB0) | 4-87 |
| 4.23.1 | Assigning Parameters to the SM 422; DO 16 × 20-120 VAC/2 A | 4-90 |
| 4.24 | Relay Output Module SM 422; DO 16 × 30/230 VUC/Rel. 5 A; (6ES7422-1HH00-0AA0) | 4-91 |
| 5 | Analog Modules | 5-1 |
| 5.1 | Module Overview | 5-3 |
| 5.2 | Sequence of Steps from Choosing to Commissioning the Analog Modules | 5-5 |
| 5.3 | Analog Value Representation | 5-6 |
| 5.3.1 | Analog Value Representation for Analog Input Channels | 5-7 |
| 5.3.2 | Analog Value Representation for Analog Output Channels | 5-22 |
| 5.4 | Setting the Measuring Method and Measuring Ranges of the Analog Input Channels | 5-27 |
| 5.5 | Behavior of the Analog Modules | 5-30 |
| 5.5.1 | Effect of Supply Voltage and Operating Mode | 5-30 |
| 5.5.2 | Effect of Range of Values of the Analog Values | 5-31 |
| 5.5.3 | Effect of Operational Limit and Basic Error Limit | 5-32 |
| 5.6 | Conversion, Cycle, Setting and Response Time of Analog Modules | 5-34 |
| 5.7 | Analog Module Parameter Assignment | 5-38 |
| 5.7.1 | Parameters of the Analog Input Modules | 5-39 |
| 5.7.2 | Parameters of the Analog Output Modules | 5-41 |
| 5.8 | Connecting Sensors to Analog Inputs | 5-42 |
| 5.9 | Connecting Voltage Sensors | 5-45 |
| 5.10 | Connecting Current Sensors | 5-46 |
| 5.11 | Connecting Resistance Thermometers and Resistors | 5-49 |
| 5.12 | Connecting Thermocouples | 5-52 |

| | | |
|--------|--|-------|
| 5.13 | Connecting Loads/Actuators to Analog Outputs | 5-58 |
| 5.14 | Connecting Loads/Actuators to Voltage Outputs | 5-59 |
| 5.15 | Connecting Loads/Actuators to Current Outputs | 5-61 |
| 5.16 | Diagnostics of the Analog Modules | 5-62 |
| 5.17 | Analog Module Interrupts | 5-66 |
| 5.18 | Analog Input Module SM 431; AI 8 × 13 Bit; (6ES7431-1KF00-0AB0) .. | 5-69 |
| 5.18.1 | Commissioning the SM 431; AI 8 × 13 Bit | 5-73 |
| 5.18.2 | Measuring Methods and Measuring Ranges of the SM 431; AI 8 13 Bit . | 5-74 |
| 5.19 | Analog Input Module SM 431; AI 8 × 14 Bit; (6ES7 431-1KF10-0AB0) . | 5-76 |
| 5.19.1 | Commissioning the SM 431; AI 8 × 14 Bit | 5-82 |
| 5.19.2 | Measuring Methods and Measuring Ranges of the SM 431; AI 8 14 Bit . | 5-84 |
| 5.20 | Analog Input Module SM 431; AI 8 × 4 Bit; (6ES7431-1KF20-0AB0) ... | 5-89 |
| 5.20.1 | Commissioning the SM 431; AI 8 × 4 Bit | 5-93 |
| 5.20.2 | Measuring Methods and Measuring Ranges of the SM 431; AI 8 × 4 Bit | 5-95 |
| 5.21 | Analog Input Module SM 431; AI 16 × 13 Bit; (6ES7431-0HH00-0AB0) | 5-98 |
| 5.21.1 | Commissioning the SM 431; AI 16 × 13 Bit | 5-103 |
| 5.21.2 | Measuring Methods and Measuring Ranges of the SM 431; AI 16 × 13 Bit | 5-104 |
| 5.22 | Analog Input Module SM 431; AI 16 × 16 Bit; (6ES7431-7QH00-0AB0) | 5-106 |
| 5.22.1 | Commissioning the SM 431; AI 16 × 16 Bit | 5-114 |
| 5.22.2 | Measuring Methods and Measuring Ranges of the SM 431; AI 16 × 16 Bit | 5-117 |
| 5.23 | Analog Input Module SM 431; AI 8 × RTD × 16 Bit; (6ES7 431-7KF10-0AB0) | 5-122 |
| 5.23.1 | Commissioning the SM 431; AI 8 × RTD × 16 Bit | 5-126 |
| 5.23.2 | Measuring Methods and Measuring Ranges of the SM 431; AI 8 × RTD × 16 Bit | 5-129 |
| 5.24 | Analog Input Module SM 431; AI 8 × 16 Bit; (6ES7431-7KF00-0AB0) | 5-130 |
| 5.24.1 | Commissioning the SM 431; AI 8 × 16 Bit | 5-135 |
| 5.24.2 | Measuring Methods and Measuring Ranges of the SM 431; AI 8 × 16 Bit | 5-139 |
| 5.25 | Analog Output Module SM 432; AO 8 × 13 Bit; (6ES7432-1HF00-0AB0) | 5-141 |
| 5.25.1 | Commissioning the SM 432; AO 8 × 13 Bit | 5-145 |
| 5.25.2 | Output Ranges of the Analog Output Module SM 432; AO 8 × 13 Bit | 5-145 |

| | | |
|----------|---|------------|
| 6 | Interface Modules | 6-1 |
| 6.1 | Common Features of the Interface Modules | 6-2 |
| 6.2 | The Interface Modules IM 460-0; (6ES7460-0AA00-0AB0, 6ES7460-0AA01-0AB0) and IM 461-0; (6ES7461-0AA00-0AA0, 6ES7461-0AA01-0AA0) | 6-7 |
| 6.3 | The Interface Modules IM 460-1; (6ES7460-1BA00-0AB0, 6ES7460-1BA01-0AB0) and IM 461-1; (6ES7461-1BA00-0AA0, 6ES7461-1BA01-0AA0) | 6-10 |
| 6.4 | The Interface Modules IM 460-3; (6ES7460-3AA00-0AB0, 6ES7460-3AA01-0AB0) and IM 461-3; (6ES7461-3AA00-0AA0, 6ES7461-3AA01-0AA0) | 6-14 |
| 6.5 | The Interface Modules IM 460-4; (6ES7460-4AA01-0AB0) and IM 461-4; (6ES7461-4AA01-0AA0) | 6-18 |
| 7 | IM 463-2 | 7-1 |
| 7.1 | Using SIMATIC S5 Expansion Units in an S7-400 | 7-2 |
| 7.2 | Rules for Connecting S5 Expansion Units | 7-3 |
| 7.3 | Operator Controls and Indicators | 7-4 |
| 7.4 | Installing and Connecting the IM 463-2 | 7-6 |
| 7.5 | Setting the Operating Modes of the IM 314 | 7-8 |
| 7.6 | Configuring S5 Modules for Operation in the S7-400 | 7-10 |
| 7.7 | Pin Assignments of the 721 Connecting Cable | 7-11 |
| 7.8 | Terminating Connector for IM 314 | 7-13 |
| 7.9 | Technical Specifications (6ES7463-2AA00-0AA0) | 7-14 |
| 8 | PROFIBUS DP Master Interface IM 467/IM 467 FO | 8-1 |
| 8.1 | PROFIBUS DP Master Interface IM 467/IM 467 FO | 8-2 |
| 8.1.1 | Indicators and the Mode Selector | 8-4 |
| 8.2 | Configuration | 8-6 |
| 8.3 | Connection to PROFIBUS DP | 8-8 |
| 8.3.1 | Bus Connector | 8-8 |
| 8.3.2 | Optical Connection to PROFIBUS DP | 8-9 |
| 8.3.3 | Connecting a Fiber-Optic Cable to the IM 467 FO | 8-10 |
| 8.4 | Technical Specifications | 8-12 |
| 8.4.1 | Technical Specifications of the IM 467 | 8-12 |
| 8.4.2 | Technical Specifications of the IM 467 FO | 8-13 |
| 9 | Cable Duct and Fan Subassemblies | 9-1 |
| 9.1 | Fan Monitoring in the Fan Subassemblies | 9-2 |
| 9.2 | Cable Duct; (6ES7408-0TA00-0AA0) | 9-4 |
| 9.3 | The 120/230 VAC Fan Subassembly; (6ES7408-1TB00-0XA0) | 9-5 |
| 9.4 | The 24 VDC Fan Subassembly; (6ES7408-1TA00-0XA0) | 9-7 |

| | | |
|-----------|---|-------------|
| 10 | RS 485 Repeater | 10-1 |
| 10.1 | Application and Characteristics (6ES7972-0AA01-0XA0) | 10-2 |
| 10.2 | Appearance of the RS 485 Repeater; (6ES7972-0AA01-0XA0) | 10-3 |
| 10.3 | RS 485 Repeater in Ungrounded and Grounded Operation | 10-4 |
| 10.4 | Technical Specifications | 10-6 |
| 11 | CPUs for M7-400 | 11-1 |
| 11.1 | Performance Features | 11-2 |
| 11.2 | Technical Specifications | 11-3 |
| 11.3 | Function Elements | 11-4 |
| 11.3.1 | Status and Fault LEDs | 11-6 |
| 11.3.2 | Memory Cards | 11-8 |
| 11.3.3 | Mode Selector Switch | 11-9 |
| 11.3.4 | Submodule Receptacles for Interface Submodules | 11-11 |
| 11.3.5 | Memory Submodules Suitable for the Main Memory | 11-13 |
| 11.3.6 | Expansion Socket | 11-14 |
| 11.3.7 | Multipoint Interface (MPI) | 11-15 |
| 11.4 | The BIOS Setup | 11-16 |
| 11.4.1 | BIOS Power Up | 11-17 |
| 11.4.2 | BIOS Hot Keys | 11-19 |
| 11.4.3 | Operator Inputs in the BIOS Setup | 11-20 |
| 11.4.4 | Opening and Exiting the BIOS Setup | 11-23 |
| 11.4.5 | Setup Page "User Help" | 11-25 |
| 11.4.6 | Setup Page "IF modules" | 11-26 |
| 11.4.7 | Setup Page "Timeout Function" | 11-30 |
| 11.4.8 | Setup Page "Security" | 11-31 |
| 11.4.9 | Setup Page "Date and Time" | 11-33 |
| 11.4.10 | "Hard Disk" Setup Page | 11-34 |
| 11.4.11 | Setup Page "Floppy/Card" | 11-36 |
| 11.4.12 | Setup Page "Boot Options" | 11-37 |
| 11.4.13 | Setup Page "System" | 11-39 |
| 11.5 | I/O Addresses, Main Memory and Interrupt Assignments | 11-41 |
| 12 | M7-400 Expansions | 12-1 |
| 12.1 | Overview | 12-2 |
| 12.2 | EXM 478 Expansion Module; (6ES7 478-2AC00-0AC0) | 12-6 |
| 12.2.1 | Addressing the EXM 478 Expansion Module | 12-7 |
| 12.2.2 | Interrupt Assignments, Signal Switching EXM 478 | 12-13 |
| 12.2.3 | Technical Specifications of the EXM 478 Expansion Module | 12-14 |
| 12.3 | ATM 478 AT Adapter Module; (6ES7 478-2CA00-0AC0) | 12-15 |
| 12.3.1 | Pin Assignments of the AT Module | 12-16 |
| 12.3.2 | Technical Specifications of the ATM 478 AT Adapter Module | 12-19 |
| 12.4 | MSM 478 Mass Storage Module; (6ES7 478-2BA00-0AC0) | 12-22 |
| 12.4.1 | LPT1 Parallel Port | 12-23 |
| 12.4.2 | Technical Specifications of the MSM 478 Mass Storage Module | 12-25 |

| | | |
|-----------|--|-------------|
| 13 | Interface Submodules | 13-1 |
| 13.1 | Interface Submodules Overview | 13-2 |
| 13.2 | Submodule IDs and Insertion Rules | 13-4 |
| 13.3 | IF 962-VGA Interface Submodule for M7-300/400; (6ES7962-1BA00-0AC0) | 13-5 |
| 13.3.1 | Pin Assignments | 13-6 |
| 13.3.2 | Addressing, Interrupts, and Submodule ID | 13-7 |
| 13.3.3 | Technical Specifications | 13-8 |
| 13.4 | IF 962-COM Interface Submodule for M7-300/400; (6ES7962-3AA00-0AC0) | 13-10 |
| 13.4.1 | Pin Assignments | 13-11 |
| 13.4.2 | Addressing and Interrupts | 13-12 |
| 13.4.3 | Technical Specifications | 13-15 |
| 13.5 | IF 962-LPT Interface Submodule for M7-300/400; (6ES7962-4AA00-0AC0) | 13-16 |
| 13.5.1 | Pin Assignments | 13-17 |
| 13.5.2 | Addressing and Interrupts | 13-18 |
| 13.5.3 | Technical Specifications | 13-22 |
| 13.6 | IF 961-DIO Interface Submodule for M7-300/400; (6ES7961-1AA00-0AC0) | 13-23 |
| 13.6.1 | Pin Assignments | 13-24 |
| 13.6.2 | Addressing and Interrupts | 13-26 |
| 13.6.3 | Technical Specifications | 13-31 |
| 13.7 | IF 961-AIO Interface Submodule for M7-300/400; (6ES7961-2AA00-0AC0) | 13-33 |
| 13.7.1 | Pin Assignments and Terminal Connection Diagram | 13-34 |
| 13.7.2 | Connecting Measured Value Sensors to Analog Inputs | 13-37 |
| 13.7.3 | Connecting Loads/Actuators to Analog Outputs | 13-42 |
| 13.7.4 | Conversion Time and Cycle Time of the Analog Input Channels | 13-44 |
| 13.7.5 | Conversion Time, Cycle Time, Settling Time, and Response Time of the Analog Output Channels | 13-45 |
| 13.7.6 | Starting Up the IF 961-AIO Interface Submodule | 13-46 |
| 13.7.7 | Addressing | 13-46 |
| 13.7.8 | Analog Output Function | 13-47 |
| 13.7.9 | Analog Input Function | 13-48 |
| 13.7.10 | Analog Value Representation for the Measuring Ranges of the Analog Inputs | 13-51 |
| 13.7.11 | Analog Value Representation for the Measuring Ranges of the Analog Outputs | 13-52 |
| 13.7.12 | Diagnostics, Interrupts, and Submodule ID | 13-53 |
| 13.7.13 | Technical Specifications | 13-54 |
| 13.8 | IF 961-CT1 Interface Submodule for M7-300/400; (6ES7961-3AA00-0AC0) | 13-56 |
| 13.8.1 | What Can the IF961-CT1 Interface Submodule Do? | 13-57 |
| 13.8.2 | Addressing and Interrupts | 13-59 |
| 13.8.3 | Technical Specifications | 13-60 |

| | | |
|----------|---|-------------------|
| 13.9 | IF 964-DP Interface Submodule for S7-400 and M7-400 | 13-61 |
| 13.9.1 | Pin Assignments | 13-63 |
| 13.9.2 | Addressing and Interrupts | 13-64 |
| 13.9.3 | Technical Specifications | 13-65 |
| A | Parameter Sets for Signal Modules | A-1 |
| A.1 | How to Assign the Parameters for Signal Modules in the User Program .. | A-2 |
| A.2 | Parameters of the Digital Input Modules | A-4 |
| A.3 | Parameters of the Digital Output Modules | A-7 |
| A.4 | Parameters of the Analog Input Modules | A-10 |
| B | Diagnostic Data of the Signal Modules | B-1 |
| B.1 | Evaluating the Diagnostic Data of the Signal Modules in the User Program | B-2 |
| B.2 | Structure and Contents of Diagnostic Data Bytes 0 and 1 | B-3 |
| B.3 | Diagnostic Data of the Digital Input Modules as of Byte 2 | B-4 |
| B.4 | Diagnostic Data of the Digital Output Modules as of Byte 2 | B-8 |
| B.5 | Diagnostic Data of the Analog Input Modules as of Byte 2 | B-14 |
| C | Spare Parts and Accessories | C-1 |
| D | Guidelines for Handling Electrostatic Sensitive Devices (ESD) | D-1 |
| D.1 | What is ESD? | D-2 |
| D.2 | Electrostatic Charging of Persons | D-3 |
| D.3 | General Protective Measures Against Electrostatic Discharge Damage .. | D-4 |
| E | List of Abbreviations | E-1 |
| | Glossary | Glossary-1 |
| | Index | Index-1 |

Figures

| | | |
|------|---|------|
| 1-1 | Power supply to the backup battery | 1-6 |
| 2-1 | Structure of a Rack with 18 Slots | 2-2 |
| 2-2 | Dimensions of the UR1 18-Slot or UR2 9-Slot Rack | 2-3 |
| 2-3 | Rack Dimensions | 2-5 |
| 2-4 | CR2 Rack | 2-7 |
| 2-5 | CR3 Rack | 2-8 |
| 2-6 | ER1 Rack with 18 Slots and ER2 Rack with 9 Slots | 2-10 |
| 3-1 | Controls and Indicators on the PS 407 20A Power Supply Module | 3-8 |
| 3-2 | Controls and Indicators of the PS 407 4A | 3-19 |
| 3-3 | Controls and Indicators of the PS 407 4 A | 3-21 |
| 3-4 | Controls and Displays of the PS 407 10A and PS 407 10A R | 3-23 |
| 3-5 | Controls and Displays of the PS 407 20A | 3-25 |
| 3-6 | Controls and Indicators of the PS 407 20 A | 3-27 |
| 3-7 | Controls and Indicators of the PS 405 4 A | 3-29 |
| 3-8 | Controls and Indicators of the PS 405 4 A | 3-31 |
| 3-9 | Controls and Indicators of the PS 405 10 A | 3-33 |
| 3-10 | Controls and Displays of the PS 405 10A and PS 405 10A R | 3-35 |
| 3-11 | Controls and Indicators of the PS 405 20 A | 3-37 |
| 3-12 | Controls and Indicators of the PS 405 20 A | 3-39 |
| 4-1 | Input Characteristic Curve for Digital Inputs | 4-16 |
| 4-2 | Terminal Assignment and Block Diagram of the SM 421; DI 32 x 24 VDC | 4-18 |
| 4-3 | Terminal Assignment and Block Diagram of the SM 421; DI 32 x 24 VDC | 4-21 |
| 4-4 | Terminal Assignment and Block Diagram of the SM 421; DI 16 x 24 VDC | 4-24 |
| 4-5 | Terminal Assignment Diagram for the Redundant Supply of Sensors of the SM 421; DI 16 x 24 VDC | 4-25 |
| 4-6 | Terminal Assignment and Block Diagram of the SM 421; DI 16 x 24 VDC | 4-33 |
| 4-7 | Terminal Assignment Diagram for the Redundant Supply of Sensors of the SM 421; DI 16 x 24 VDC | 4-34 |
| 4-8 | Terminal Assignment Diagram of the SM 421; DI 16 120 VDC | 4-42 |
| 4-9 | Terminal Assignment and Block Diagram of the SM 421; DI 16 x 24/60 VUC | 4-45 |
| 4-10 | Circuit as for Active High or Active Low Input | 4-49 |
| 4-11 | Terminal Assignment and Block Diagram of the SM 421; DI 16 x 120/230 VUC | 4-51 |
| 4-12 | Terminal Assignment and Block Diagram of the SM 421; DI 16 x 120/230 VUC | 4-54 |
| 4-13 | Terminal Assignment and Block Diagram of the SM 421; DI 32 x 120 VUC | 4-57 |
| 4-14 | Terminal Assignment and Block Diagram of the SM 422; DO 16 x 24 VDC/2 A | 4-60 |
| 4-15 | Terminal Assignment and Block Diagram of the SM 422; DO 16 x 24 VDC/2 A | 4-63 |
| 4-16 | Terminal Assignment Diagram of the SM 422; DO 16 x 20-125 VDC/1.5 A | 4-66 |
| 4-17 | Terminal Assignment and Block Diagram of the SM 422; DO 32 x 24 VDC/0.5 A | 4-71 |
| 4-18 | Terminal Assignment and Block Diagram of the SM 422; DO 32 x 24 VDC/0.5 A | 4-74 |

| | | |
|------|--|-------|
| 4-19 | Terminal Assignment and Block Diagram of the SM 422; DO 8 x 120/230 VAC/5 A | 4-80 |
| 4-20 | Terminal Assignment and Block Diagram of the SM 422; DO 16 x 120/230 VAC/2 A | 4-84 |
| 4-21 | Terminal Assignment Diagram of the SM 422; DO 16 x 20-120 VAC/2 A | 4-88 |
| 4-22 | Terminal Assignment and Block Diagram of the SM 422; DO 16 x 30/230 VUC/Rel. 5 A | 4-92 |
| 5-1 | Levering the Measuring Range Module out of the Analog Input Module . | 5-29 |
| 5-2 | Inserting the Measuring Range Module into the Analog Input Module ... | 5-30 |
| 5-3 | Example of the Relative Error of an Analog Output Module | 5-34 |
| 5-4 | Scan Time of an Analog Input or Output Module | 5-35 |
| 5-5 | Example of the Influence of Smoothing on the Step Response | 5-37 |
| 5-6 | Settling and Response Times of the Analog Output Channels | 5-38 |
| 5-7 | Connecting Isolated Sensors to an Isolated AI | 5-44 |
| 5-8 | Connecting Non-Isolated Sensors to an Isolated AI | 5-45 |
| 5-9 | Connecting Voltage Sensors to an AI | 5-46 |
| 5-10 | Connecting Two-Wire Transmitters to an Isolated AI | 5-48 |
| 5-11 | Connecting Two-Wire Transmitters to an SM 431; 8 x 13 Bit | 5-48 |
| 5-12 | Connecting Four-Wire Transmitters to an AI | 5-49 |
| 5-13 | Connecting Four-Wire Transmitters to an SM 431; 8 x 13 Bit | 5-49 |
| 5-14 | Four-Conductor Connection of Resistance Thermometers on an AI | 5-51 |
| 5-15 | Three-Wire Connection of Resistance Thermometers to an AI | 5-52 |
| 5-16 | Two-Wire Connection of Resistance Thermometers to an AI | 5-52 |
| 5-17 | Design of Thermocouples | 5-53 |
| 5-18 | Connection of Thermocouples without Compensation or Using the Reference Temperature Value to an Isolated AI | 5-56 |
| 5-19 | Connection of a Thermocouple with Reference Junction (Order No. M72166-xxx00) to an Isolated AI | 5-57 |
| 5-20 | Connection of Thermocouples of the Same Type with External Compensation by Means of a Resistance Thermometer, Connected to Channel 0 | 5-58 |
| 5-21 | Connecting Loads to a Voltage Output of an Isolated AO over a Four-Conductor Connection | 5-61 |
| 5-22 | Two-Conductor Connection of Loads to a Voltage Output of an Isolated AO | 5-61 |
| 5-23 | Connecting Loads to a Current Output of an Isolated AO | 5-62 |
| 5-24 | Start Information of OB 40: Which Event Triggered the Hardware Interrupt at the Limit Value | 5-68 |
| 5-25 | Block Diagram of the SM 431; AI 8 x 13 Bit | 5-71 |
| 5-26 | Terminal Assignment Diagram of the SM 431; AI 8 x 13 Bit | 5-72 |
| 5-27 | Block Diagram of the SM 431; AI 8 x 14 Bit | 5-77 |
| 5-28 | Terminal Assignment Diagram of the SM 431; AI 8 x 14 Bit | 5-78 |
| 5-29 | Step Response of the SM 431; AI 8 x 14 Bit | 5-84 |
| 5-30 | Block Diagram of the SM 431; AI 8 x 14 Bit | 5-90 |
| 5-31 | Terminal Assignment Diagram of the SM 431; AI 8 x 14 Bit | 5-91 |
| 5-32 | Step Response of the SM 431; AI 8 x 14 Bit (6ES7 431-1KF20-0AB0) .. | 5-96 |
| 5-33 | Block Diagram of the SM 431; AI 16 x 13 Bit | 5-100 |
| 5-34 | Terminal Assignment Diagram of the SM 431; AI 16 x 13 Bit | 5-101 |
| 5-35 | Block Diagram of the SM 431; AI 16 x 16 Bit | 5-108 |
| 5-36 | Terminal Assignment Diagram of the SM 431; AI 16 x 16 Bit | 5-109 |
| 5-37 | Step Response of the SM 431; AI 16 x 16 Bit (6ES7431-7QH00-0AB0) . | 5-116 |

| | | |
|------|--|-------|
| 5-38 | Block Diagram of the SM 431; AI 8 x RTD x 16 Bit | 5-123 |
| 5-39 | Terminal Assignment Diagram of the SM 431; AI 8 x RTD x 16 Bit | 5-124 |
| 5-40 | Step Response of the SM 431; AI 8 x RTD x 16 Bit | 5-127 |
| 5-41 | Block Diagram of the SM 431; AI 8 x 16 Bit | 5-131 |
| 5-42 | Terminal Assignment Diagram SM 431; AI 8 x 16 Bit | 5-132 |
| 5-43 | Step Response at 10 Hz Interference Frequency Suppression of the SM 431; AI 8 x 16 Bit | 5-137 |
| 5-44 | Step Response at 50 Hz Interference Frequency Suppression of the SM 431; AI 8 x 16 Bit | 5-137 |
| 5-45 | Step Response at 60 Hz Interference Frequency Suppression of the SM 431; AI 8 x 16 Bit | 5-138 |
| 5-46 | Step Response at 400 Hz Interference Frequency Suppression of the SM 431; AI 8 x 16 Bit | 5-138 |
| 5-47 | Block Diagram of the SM 432; AO 8 x 13 Bit | 5-141 |
| 5-48 | Terminal Assignment Diagram of the SM 432; AO 8 x 13 Bit | 5-142 |
| 6-1 | Example: Configuration with Send IMs, Receive IMs and Terminators ... | 6-5 |
| 6-2 | Position of the Operator Controls and Indicators of the IM 460-0 and IM 461-0 | 6-7 |
| 6-3 | Position of the Operator Controls and Indicators of the IM 460-1 and IM 461-1 | 6-10 |
| 6-4 | Position of the Operator Controls and Indicators of the IM 460-3 and IM 461-3 | 6-14 |
| 6-5 | Position of the Operator Controls and Indicators of the IM 460-4 and IM 461-4 | 6-18 |
| 7-1 | Layout of the Controls and Indicators of the IM 463-2 | 7-4 |
| 7-2 | Settings of the IM 314 with Expansion Units | 7-8 |
| 7-3 | Connection Variant for CCs and EUs via the IM 463-2 and IM 314 | 7-10 |
| 8-1 | Configuration of the IM 467/467 FO | 8-3 |
| 8-2 | LEDs of the IM 467/467 FO | 8-4 |
| 8-3 | Connecting the Bus Connector to the IM 467 | 8-8 |
| 8-4 | Connector Pin Assignment | 8-9 |
| 8-5 | Optical Connection to PROFIBUS DP | 8-9 |
| 8-6 | Installing the Connector | 8-10 |
| 8-7 | Inserting the Fiber-Optic Cables into the IM 467 FO | 8-11 |
| 9-1 | Example of a Message Concept | 9-3 |
| 9-2 | Front View of the Cable Channel | 9-4 |
| 9-3 | Controls and Indicators of the Fan Subassembly 120/230 VAC (6ES7408-1TB00-0XA0) | 9-5 |
| 9-4 | Controls and Indicators of the Fan Subassembly 24 VDC (6ES7408-1TA00-0XA0) | 9-7 |
| 10-1 | RC Network with 10 MW for Configuration with Ungrounded Reference Potential | 10-5 |
| 10-2 | Isolation Between the Bus Segments | 10-5 |
| 10-3 | Block Diagram of the RS 485 Repeater | 10-7 |
| 11-1 | Front and Rear View of a CPU 486-3 and CPU 488-3 without Covering Flap | 11-4 |
| 11-2 | Status and Fault LEDs on the CPU 486-3 and CPU 488-3 | 11-6 |
| 11-3 | Mode Selector Switch | 11-9 |
| 11-4 | Position of the Receptacles for Interface Submodules on the CPU 486-3 and CPU 488-3 | 11-11 |
| 11-5 | Submodule Receptacle Numbers on the CPU486-3/CPU488-3 and EXM478 | 11-12 |

| | | |
|-------|--|-------|
| 11-6 | POST Window for a CPU 488-3 | 11-17 |
| 11-7 | Warm Restart Window for a CPU | 11-18 |
| 11-8 | Context-Sensitive Help Window | 11-22 |
| 11-9 | Setup Menu | 11-23 |
| 11-10 | "Setup Exit" Dialog Box | 11-24 |
| 11-11 | "User Help" Setup Page | 11-25 |
| 11-12 | "IF Modules" Setup Page | 11-26 |
| 11-13 | Setup Page "Timeout Function" | 11-30 |
| 11-14 | "Security" Setup Page | 11-31 |
| 11-15 | "Date and Time" Setup Page (Default) | 11-33 |
| 11-16 | "Hard Disk" Setup Page with only the Master Hard Disk Present | 11-34 |
| 11-17 | "Floppy/Card" Setup Page | 11-36 |
| 11-18 | "Boot Options" Setup Page | 11-37 |
| 11-19 | "System" Setup Page | 11-39 |
| 12-1 | Positions of Expansion Socket and Expansion Connector | 12-3 |
| 12-2 | Maximum Expansion with Expansion Modules | 12-4 |
| 12-3 | EXM 478 Expansion Module | 12-6 |
| 12-4 | Submodule Receptacle Numbers for the FM 456-4 and EXM 478 | 12-8 |
| 12-5 | Submodule Receptacle Numbers for the CPU 486-3, CPU 488-3, and EXM 478 | 12-9 |
| 12-6 | Base Addresses of the Expansion Modules and the Interface Submodules | 12-10 |
| 12-7 | ATM 478 AT Adapter Module | 12-15 |
| 12-8 | ATM 478 AT Adapter Module, 98-Pin Standard Direct Connector | 12-16 |
| 12-9 | Dimension Specifications for AT Modules to be Installed in an ATM 478 .. | 12-21 |
| 12-10 | MSM 478 Mass Storage Module | 12-22 |
| 13-1 | IF 962-VGA Interface Submodule | 13-5 |
| 13-2 | X2 Socket, Keyboard Plug Connection IF 961-VGA (6-Pin Mini DIN Socket Connector) | 13-6 |
| 13-3 | IF 962-COM Interface Submodule | 13-10 |
| 13-4 | IF 962-LPT Interface Submodule | 13-16 |
| 13-5 | IF 961-DIO Interface Submodule | 13-23 |
| 13-6 | X1 Socket Assignments, IF 961-DIO (25-Pin Sub D Connector) | 13-24 |
| 13-7 | Circuit Block Diagram and Terminal Connection Diagram for Wiring the Digital Inputs | 13-25 |
| 13-8 | Circuit Block Diagram and Terminal Connection Diagram for Wiring the Digital Outputs | 13-25 |
| 13-9 | IF 961-AIO Interface Submodule | 13-33 |
| 13-10 | X1 Socket Assignments (25-Pin Sub D Connector) and Terminal Connection Diagram of the IF 961-AIO | 13-34 |
| 13-11 | Circuit Block Diagram of the IF 961-AIO Interface Submodule | 13-35 |
| 13-12 | Grounding the Analog Inputs/Outputs of the Interface Submodule IF 961-AIO | 13-36 |
| 13-13 | Connection of Isolated Measured Value Sensors | 13-38 |
| 13-14 | Connection of Non-Isolated Measured Value Sensors | 13-39 |
| 13-15 | Connection of Voltage Sensors | 13-39 |
| 13-16 | Connection of Two-Wire Transducers | 13-40 |
| 13-17 | Connection of Four-Wire Transducers | 13-40 |
| 13-18 | Four-Wire Connection of Resistance Thermometers/Resistances with One Constant Current Source Each | 13-41 |
| 13-19 | Four-Wire Connection of Resistance Thermometers/Resistances with a Common Constant Current Source | 13-41 |

| | | |
|-------|---|-------|
| 13-20 | Connecting Loads/Actuators via a Two-Wire Connection to a Current Output | 13-42 |
| 13-21 | Connecting Loads/Actuators via a Three-Wire Connection to a Voltage Output | 13-43 |
| 13-22 | Cycle Time of the Analog Input Module | 13-44 |
| 13-23 | Response Time of the Analog Output Channels | 13-45 |
| 13-24 | IF 961-CT1 Interface Submodule | 13-56 |
| 13-25 | IF 964-DP Interface Submodule | 13-61 |
| A-1 | Data Record 1 of the Parameters of the Digital Input Modules | A-5 |
| A-2 | Data Record 1 for Parameters of the Digital Input Modules | A-6 |
| A-3 | Data Record 1 for Parameters of the Digital Output Modules | A-8 |
| A-4 | Data Record 1 for Parameters of the Digital Output Modules | A-9 |
| A-5 | Data Record 1 for Parameters of the Analog Input Modules | A-11 |
| B-1 | Bytes 0 and 1 of the Diagnostic Data | B-3 |
| B-2 | Bytes 2 and 3 of the Diagnostic Data of the SM 421; DI 16 x 24 VDC ... | B-4 |
| B-3 | Bytes 4 to 8 of the Diagnostic Data of the SM 421; DI 16 x 24 VDC | B-5 |
| B-4 | Diagnostic Byte for a Channel of the SM 421; DI 16 x 24 VDC | B-5 |
| B-5 | Bytes 2 and 3 of the Diagnostic Data of the SM 421; DI 16 x 24/60 VUC | B-6 |
| B-6 | Bytes 4 to 8 of the Diagnostic Data of the SM 421; DI 16 x 24/60 VUC .. | B-6 |
| B-7 | Diagnostic Byte for a Channel of the SM 421; DI 16 x 24/60 VUC | B-7 |
| B-8 | Bytes 2 and 3 of the Diagnostic Data of the SM 422; DO 16 x 20-125 VDC/1.5 A | B-8 |
| B-9 | Bytes 4 to 8 of the Diagnostic Data of the SM 422; DO 16 x 20-125 VDC/1.5 A | B-9 |
| B-10 | Diagnostic Byte for a Channel of the SM 422; DO 16 x 20-125 VDC/1.5 A | B-9 |
| B-11 | Bytes 2 and 3 of the Diagnostic Data of the SM 422; DO 32 x 24 VDC/0.5 A | B-10 |
| B-12 | Bytes 4 to 10 of the Diagnostic Data of the SM 422; DO 32 x 24 VDC/0.5 A | B-11 |
| B-13 | Diagnostic Byte for a Channel of the SM 422; DO 32 x 24 VDC/0.5 A ... | B-12 |
| B-14 | Bytes 2 and 3 of the Diagnostic Data of the SM 422; DO 16 x 20-120 VAC/2 A | B-12 |
| B-15 | Bytes 4 to 8 of the Diagnostic Data of the SM 422; DO 16 x 20-120 VAC/2 A | B-13 |
| B-16 | Diagnostic Byte for a Channel of the SM 422; DO 16 x 20-120 VAC/2 A . | B-13 |
| B-17 | Bytes 2 and 3 of the Diagnostic Data of the SM 431; AI 16 x 16 Bit | B-14 |
| B-18 | Bytes 4 to 8 of the Diagnostic Data of the SM 431; AI 16 x 16 Bit | B-15 |
| B-19 | Diagnostic Byte for a Channel of the SM 431; AI 16 x 16 Bit | B-15 |
| B-20 | Bytes 2 and 3 of the Diagnostic Data of the SM 431; AI 8 x RTD x 16 Bit | B-16 |
| B-21 | Bytes 4 to 7 of the Diagnostic Data of the SM 431; AI 8 x RTD x 16 Bit .. | B-16 |
| B-22 | Even Diagnostic Byte for a Channel of the SM 431; AI 8 x RTD x 16 Bit . | B-17 |
| B-23 | Odd Diagnostic Byte for a Channel of the SM 431; AI 8 x RTD x 16 Bit .. | B-17 |
| B-24 | Bytes 2 and 3 of the Diagnostic Data of the SM 431; AI 8 x 16 Bit | B-18 |
| B-25 | Bytes 4 to 7 of the Diagnostic Data of the SM 431; AI 8 x 16 Bit | B-18 |
| B-26 | Even Diagnostic Byte for a Channel of the SM 431; AI 8 x 16 Bit | B-19 |
| B-27 | Odd Diagnostic Byte for a Channel of the SM 431; AI 8 x 16 Bit | B-19 |
| D-1 | Electrostatic Voltages which Can Build up on a Person | D-3 |

Tables

| | | |
|------|---|------|
| 1-1 | Use in an Industrial Environment | 1-2 |
| 1-2 | Products that Fulfill the Requirements of the Low-Voltage Directive | 1-3 |
| 1-3 | Power Supply Modules | 1-8 |
| 1-4 | Pulse-Shaped Interference | 1-10 |
| 1-5 | Sinusoidal Interference | 1-10 |
| 1-6 | Interference emission of electromagnet fields | 1-11 |
| 1-7 | Interference emission via the mains AC power supply | 1-11 |
| 1-8 | Power Supply Modules that Comply with System Perturbation Standards | 1-11 |
| 1-9 | Shipping and Storage Conditions for Modules | 1-12 |
| 1-10 | Mechanical Conditions | 1-14 |
| 1-11 | Ambient Mechanical Conditions for the MSM 478 Mass Storage Module in Operation | 1-15 |
| 1-12 | Ambient Mechanical Conditions Test | 1-15 |
| 1-13 | Ambient Climatic Conditions for the S7-400 | 1-15 |
| 1-14 | Power Supply Modules for Use at up to + 1500 m | 1-16 |
| 1-15 | Ambient Climatic Conditions for the M7-400 | 1-17 |
| 1-16 | Test Voltages | 1-18 |
| 3-1 | Compliance with the NAMUR recommendation | 3-3 |
| 3-2 | Redundant power supply modules | 3-4 |
| 3-3 | INTF, DC 5V, DC 24 V LEDs | 3-9 |
| 3-4 | BAF, BATTF LEDs | 3-9 |
| 3-5 | BAF, BATT1F, BATT2F LEDs | 3-9 |
| 3-6 | Function of the operator controls of the power supply modules | 3-11 |
| 3-7 | Error messages of the power supply modules | 3-13 |
| 3-8 | INTF, DC5V, DC24V LEDs | 3-13 |
| 3-9 | BAF, BATTF; BATT INDIC LEDs on BATT | 3-16 |
| 3-10 | BAF, BATT1F, BATT2F; BATT INDIC LEDs on 1BATT | 3-17 |
| 3-11 | BAF, BATT1F, BATT2F; BATT INDIC LEDs on 2BATT | 3-18 |
| 4-1 | Digital Input Modules: Characteristics at a Glance | 4-3 |
| 4-2 | Digital Output Modules: Characteristics at a Glance | 4-4 |
| 4-3 | Relay Output Module: Characteristics at a Glance | 4-4 |
| 4-4 | Sequence of Steps from Choosing to Commissioning the Digital Module | 4-5 |
| 4-5 | Static and dynamic parameters of the digital modules | 4-6 |
| 4-6 | Parameters of the Digital Input Modules | 4-7 |
| 4-7 | Parameters of the Digital Output Modules | 4-8 |
| 4-8 | Diagnostic Messages of the Digital Modules | 4-10 |
| 4-9 | Diagnostic Messages of the Digital Modules, Causes of Errors and Remedial Measures | 4-11 |
| 4-10 | Parameters of the SM 421; DI 16 × 24 VDC | 4-27 |
| 4-11 | How the Input Values Depend on the Operating Mode of the CPU and on the Supply Voltage L+ of the SM 421; DI 16 × 24 VDC | 4-29 |
| 4-12 | How the Input Values Are Affected by Faults and by the Parameter Assignment of the SM 421; DI 16 × 24 VDC | 4-30 |
| 4-13 | Parameters of the SM 421; DI 16 × 24 VDC | 4-36 |
| 4-14 | How the Input Values Depend on the Operating Mode of the CPU and on the Supply Voltage L+ of the SM 421; DI 16 × 24 VDC | 4-38 |
| 4-15 | How the Input Values Are Affected by Faults and by the Parameter Assignment of the SM 421; DI 16 × 24 VDC | 4-39 |
| 4-16 | Parameters of the SM 421; DI 16 × 24/60 VDC | 4-47 |

| | | |
|------|---|------|
| 4-17 | Parameters of the SM 422; DO 16 × 20-125 VDC/1.5 A | 4-69 |
| 4-18 | Parameters of the SM 422; DO 32 × 24 VDC/0.5 A (6ES7422-7BL00-0AB0) | 4-77 |
| 4-19 | Dependence of the Output Values on the Operating Mode of the CPU and on the Supply Voltage L+ of the SM 422; DO 32 × 24 VDC/0.5 A .. | 4-78 |
| 4-20 | Parameters of the SM 422; DO 16 × 20-120 VAC/2 A | 4-90 |
| 5-1 | Analog Input Modules: Characteristics at a Glance | 5-3 |
| 5-2 | Analog Output Modules: Characteristics at a Glance | 5-4 |
| 5-3 | Sequence of Steps from Choosing to Commissioning the Analog Module | 5-6 |
| 5-4 | Example: Bit Pattern of a 16-Bit and a 13-Bit Analog Value | 5-8 |
| 5-5 | Possible Resolutions of the Analog Values | 5-9 |
| 5-6 | Bipolar Input Ranges | 5-10 |
| 5-7 | Unipolar Input Ranges | 5-10 |
| 5-8 | Life-Zero Input Ranges | 5-11 |
| 5-9 | Analog Value Representation in Voltage Measuring Ranges + 10 V to + 1 V | 5-11 |
| 5-10 | Analog Value Representation in the Voltage Measuring Ranges + 500 mV to + 25 mV | 5-12 |
| 5-11 | Analog Value Representation in the Voltage Measuring Ranges 1 to 5 V and 0 to 10 V | 5-12 |
| 5-12 | Analog Value Representation in the Current Measuring Ranges + 20 mA to + 3.2 mA | 5-13 |
| 5-13 | Analog Value Representation in Current Measuring Ranges 0 to 20 mA .. | 5-13 |
| 5-14 | Analog Value Representation in Current Measuring Ranges 4 to 20 mA .. | 5-14 |
| 5-15 | Analog Value Representation for Resistance-Type Sensors from 48 W to 6 kW | 5-14 |
| 5-16 | Analog Value Representation for Resistance Thermometers Pt 100, 200, 500,1000 | 5-15 |
| 5-17 | Analog Value Representation for Resistance Thermometers Pt 100, 200, 500,1000 | 5-15 |
| 5-18 | Analog Value Representation for Resistance Thermometers Ni100, 120, 200, 500, 1000 | 5-16 |
| 5-19 | Analog Value Representation for Resistance Thermometers Ni 100, 120, 200, 500, 1000 | 5-16 |
| 5-20 | Analog Value Representation for Resistance Thermometers Cu 10 | 5-17 |
| 5-21 | Analog Value Representation for Resistance Thermometers Cu 10 | 5-17 |
| 5-22 | Analog Value Representation for Thermocouple Type B | 5-18 |
| 5-23 | Analog Value Representation for Thermocouple Type E | 5-18 |
| 5-24 | Analog Value Representation for Thermocouple Type J | 5-19 |
| 5-25 | Analog Value Representation for Thermocouple Type K | 5-19 |
| 5-26 | Analog Value Representation for Thermocouple Type L | 5-20 |
| 5-27 | Analog Value Representation for Thermocouple Type N | 5-20 |
| 5-28 | Analog Value Representation for Thermocouple Types R, S | 5-21 |
| 5-29 | Analog Value Representation for Thermocouple Type T | 5-21 |
| 5-30 | Analog Value Representation for Thermocouple Type U | 5-22 |
| 5-31 | Bipolar Output Ranges | 5-23 |
| 5-32 | Unipolar Output Ranges | 5-24 |
| 5-33 | Life-Zero Output Ranges | 5-25 |
| 5-34 | Analog Value Representation in Output Range + 10 V | 5-26 |
| 5-35 | Analog Value Representation in Output Ranges 0 to 10 V and 1 to 5 V .. | 5-26 |
| 5-36 | Analog Value Representation in Output Range + 20 mA | 5-27 |

| | | |
|------|---|-------|
| 5-37 | Analog Value Representation in Output Ranges 0 and 20 mA and 4 to 20 mA | 5-27 |
| 5-38 | Dependencies of the Analog Input/Output Values on the Operating Mode of the CPU and the Supply Voltage L+ | 5-31 |
| 5-39 | Behavior of the Analog Input Modules as a Function of the Position of the Analog Value Within the Range of Values | 5-32 |
| 5-40 | Behavior of the Analog Output Modules as a Function of the Position of the Analog Value Within the Range of Values | 5-33 |
| 5-41 | Static and dynamic parameters of the analog groups | 5-39 |
| 5-42 | Parameters of the Analog Input Modules | 5-40 |
| 5-43 | Parameters of the Analog Output Modules | 5-42 |
| 5-44 | Options for Compensation of the Reference Junction Temperature | 5-54 |
| 5-45 | Ordering Data of the Comparison Point | 5-57 |
| 5-46 | Diagnostic Messages of the Analog Input Modules | 5-64 |
| 5-47 | Diagnostics Messages of the Analog Input Modules, Causes of Errors and Remedial Measures | 5-65 |
| 5-48 | Parameters of the SM 431; AI 8 x 13 Bit | 5-74 |
| 5-49 | Channels for Resistance Measurement of the SM 431; AI 8 x 13 Bit | 5-75 |
| 5-50 | Measuring Ranges of the SM 431; AI 8 x 13 Bit | 5-76 |
| 5-51 | Parameters of the SM 431; AI 8 x 14 Bit | 5-83 |
| 5-52 | Selection of the Measuring Method for Channel n and Channel n+1 of the SM 431; AI 8 x 14 Bit | 5-85 |
| 5-53 | Channels for Resistance and Temperature Measurement with the SM 431; AI 8 x 14 Bit | 5-86 |
| 5-54 | Thermocouple with Reference Junction Compensation via RTD on Channel 0 | 5-86 |
| 5-55 | Measuring Ranges of the SM 431; AI 8 x 14 Bit | 5-87 |
| 5-56 | Parameters of the SM 431; AI 8 x 14 Bit (6ES7431-1KF20-0AB0) | 5-94 |
| 5-57 | Interference Frequency Suppression and Filter Settling Time with Smoothing of the SM 431; AI 8 x 14 Bit (6ES7431-1KF20-0AB0) ... | 5-95 |
| 5-58 | Selection of the Measuring Method for Channel n and Channel n+1 of the SM 431; AI 8 x 14 Bit (6ES7 431-1KF20-0AB0) | 5-97 |
| 5-59 | Channels for Resistance Measurement of the SM 431; AI 8 x 14 Bit (6ES7431-1KF20-0AB0) | 5-97 |
| 5-60 | Measuring Ranges of the SM 431; AI 8 x 14 Bit (6ES7431-1KF20-0AB0) | 5-98 |
| 5-61 | Parameters of the SM 431; AI 16 x 13 Bit | 5-104 |
| 5-62 | Selection of the Measuring Method for Channel n and Channel n+1 of the SM 431; AI 16 x 13 Bit | 5-105 |
| 5-63 | Measuring Ranges of the SM 431; AI 16 x 13 Bit | 5-106 |
| 5-64 | Parameters of the SM 431; AI 16 x 16 Bit | 5-114 |
| 5-65 | Diagnostic Information of the SM 431; AI 16 x 16 Bit | 5-116 |
| 5-66 | Selection of the Measuring Method for Channel n and Channel n+1 of the SM 431; AI 16 x 16 Bit | 5-117 |
| 5-67 | Channels for Resistance and Temperature Measurement of the SM 431; AI 16 x 16 Bit | 5-118 |
| 5-68 | Reference Junction Compensation via RTD on Channel 0 of the SM 431; AI 16 x 16 Bit | 5-118 |
| 5-69 | Measuring Ranges of the SM 431; AI 16 x 16 Bit | 5-119 |
| 5-70 | Points to Note when Checking for "Underflow" | 5-121 |
| 5-71 | Parameters of the SM 431; AI 8 x RTD x 16 Bit | 5-126 |
| 5-72 | Diagnostic Information of the SM 431; AI 8 x RTD x 16 Bit | 5-128 |
| 5-73 | Measuring Ranges of the SM 431; AI 8 x RTD x 16 Bit | 5-129 |

| | | |
|------|--|-------|
| 5-74 | Parameters of the SM 431; AI 8 x 16 Bit | 5-135 |
| 5-75 | How Response Times Depend on the Parameterized Interference Frequency Suppression and Smoothing of the SM 431; AI 8 x 16 Bit | 5-136 |
| 5-76 | Diagnostic Information of the SM 431; AI 8 x 16 Bit | 5-139 |
| 5-77 | Measuring Ranges of the SM 431; AI 8 x 16 Bit | 5-140 |
| 5-78 | Output Ranges of the Analog Output Module SM 432; AO8 x 13 Bit | 5-145 |
| 6-1 | Interface Modules of the S7-400 | 6-2 |
| 6-2 | Terminators for the Receive IMs | 6-4 |
| 6-3 | Connecting Cable for Interface Modules | 6-5 |
| 7-1 | S5 Interface Modules | 7-2 |
| 7-2 | LEDs of the IM 4632 | 7-5 |
| 7-3 | LEDs of the IM 463-2 | 7-5 |
| 7-4 | Switch Position: Interface Selector of the IM 463-2 | 7-5 |
| 7-5 | Settings Address Areas on the IM 314 | 7-9 |
| 7-6 | Assignment of the Connecting Cable 721 | 7-11 |
| 7-7 | Assignment of the Terminator 760-1AA11 | 7-13 |
| 8-1 | Operating Modes of the IM 467/467 FO | 8-4 |
| 8-2 | CPU and IM 467/467 FO | 8-7 |
| 9-1 | Function of Fan Monitoring | 9-2 |
| 10-1 | Maximum Cable Length of a Segment | 10-2 |
| 10-2 | Maximum Cable Length between Two RS 485 Repeaters | 10-2 |
| 10-3 | Description and Functions of the RS 485 Repeater | 10-3 |
| 11-1 | Performance Features of the CPUs | 11-2 |
| 11-2 | Technical Specifications of the CPUs | 11-3 |
| 11-3 | Elements of the CPU 486-3 and CPU 488-3 | 11-5 |
| 11-4 | Meaning of the Status and Fault LEDs on the CPU 486-3 and CPU 488-3 | 11-7 |
| 11-5 | Positions of the Mode Selector Switch | 11-9 |
| 11-6 | Main Memory Expansion Possibilities | 11-13 |
| 11-7 | BIOS Hot Keys with German and English Key Assignments | 11-19 |
| 11-8 | Main Memory Assignment | 11-41 |
| 11-9 | Interrupt Assignment | 11-43 |
| 12-1 | Expansion Possibilities of the CPU 486-3, CPU 488-3, or FM 456 | 12-5 |
| 12-2 | Division of Addresses Within an Expansion Module | 12-11 |
| 12-3 | Base Addresses of the Interface Submodules with FM 456-4 | 12-12 |
| 12-4 | Base Addresses of the Expansion Modules with CPU 486-3, CPU 488-3 | 12-12 |
| 12-5 | Pin Assignments of the 98-Pin Standard Direct Connector (ATConnector) | 12-17 |
| 12-6 | Calculation Example for Total Power Losses of an ATM 478 with AT Module | 12-20 |
| 12-7 | MSM 478 Parallel Port, Socket X1 (25-Pin Sub D Socket) | 12-24 |
| 13-1 | Format of the Interrupt Entry in the BIOS Setup of the Interface Submodule | 13-3 |
| 13-2 | Overview of the Submodule IDs for the Interface Submodules | 13-4 |
| 13-3 | Insertion Rules for Interface Submodules that Cannot be Used in All Receptacles | 13-4 |
| 13-4 | Socket X1, VGA Screen Connection IF 962-VGA (15-Pin High-Density Sub D Socket Connector) | 13-6 |
| 13-5 | X2 Socket, Keyboard Plug Connection IF 961-VGA (6-Pin Mini DIN Socket Connector) | 13-6 |
| 13-6 | Interrupt Assignments of the IF 962-VGA Interface Submodule | 13-7 |
| 13-7 | Video Modes of the IF 962-VGA Interface Submodule | 13-9 |

| | | |
|-------|--|-------|
| 13-8 | Socket X1, X2 IF 962-COM (9-Pin Sub D Plug Connector) | 13-11 |
| 13-9 | Addressing the COM Ports in the AT-Compatible Address Area | 13-12 |
| 13-10 | Offset Address Assignments for the IF 962-COM Interface Submodule .. | 13-13 |
| 13-11 | Offset Address for the Configuration Register (IF 962-COM) | 13-13 |
| 13-12 | Meaning of the Data Bits in the Configuration Register (IF 962-COM) ... | 13-13 |
| 13-13 | Meaning of the Addressing Type Bits in the Configuration Register (IF 962-COM) | 13-14 |
| 13-14 | Interrupt Assignments of the IF 962-COM Interface Submodule | 13-15 |
| 13-15 | Socket X1, IF 962-LPT (25-Pin Sub D Socket Connector) | 13-17 |
| 13-16 | Addressing the LPT Ports | 13-18 |
| 13-17 | Offset Address Assignments for the IF 962-LPT Interface Submodule ... | 13-19 |
| 13-18 | Offset Address for the Configuration Register (IF 962-LPT) | 13-20 |
| 13-19 | Meaning of the Data Bits in the Configuration Register (IF 962-LPT) | 13-20 |
| 13-20 | Meaning of the Addressing Type Bits in the Configuration Register (IF 962-LPT) | 13-21 |
| 13-21 | Offset Address Assignments for the IF 961-DIO Interface Submodule ... | 13-26 |
| 13-22 | Offset Address for the Digital Input Function (IF 961-DIO) | 13-26 |
| 13-23 | Assignment of the Digital Input (DI) Channels to the Bits (IF 961-DIO) .. | 13-26 |
| 13-24 | Offset Address for the Digital Output Function (IF 961-DIO) | 13-27 |
| 13-25 | Assignment of the Digital Output (DO) Channels to the Bits (IF 961-DIO) | 13-27 |
| 13-26 | Offset Address for the Acknowledgment Register (IF 961-DIO) | 13-27 |
| 13-27 | Meaning of the Bits in the Acknowledgment Register (IF 961-DIO) | 13-27 |
| 13-28 | Offset Address for the Interrupt Register (IF 961-DIO) | 13-28 |
| 13-29 | Meaning of the Bits in the Interrupt Register (IF 961-DIO) | 13-28 |
| 13-30 | Offset Address for the Interrupt Enable Register (IF 961-DIO) | 13-28 |
| 13-31 | Meaning of the Bits in the Interrupt Enable Register (IF 961-DIO) | 13-28 |
| 13-32 | Offset Address for the Selection Register Rising Edge (IF 961-DIO) | 13-29 |
| 13-33 | Meaning of the Bits in the Selection Register Rising Edge (IF 961-DIO) . | 13-29 |
| 13-34 | Offset Address for the Selection Register Falling Edge (IF 961-DIO) | 13-29 |
| 13-35 | Meaning of the Bits in the Selection Register Falling Edge (IF 961-DIO) . | 13-29 |
| 13-36 | Offset Address for the Mode Register (IF 961-DIO) | 13-30 |
| 13-37 | Meaning of the Bits in the Mode Register (IF 961-DIO) | 13-30 |
| 13-38 | Meaning of the Signals of the X1 Socket of the IF 961-AIO Interface Submodule | 13-35 |
| 13-39 | Offset Address Assignments for the IF 961-AIO Interface Submodule ... | 13-46 |
| 13-40 | Meaning of the Data Bits in the Analog Output Function (IF 961-AIO) ... | 13-47 |
| 13-41 | Meaning of the Input Bits in the Analog Input Function (IF 961-AIO) | 13-48 |
| 13-42 | Meaning of the Control Bits in the Analog Input Function (IF 961-AIO) .. | 13-49 |
| 13-43 | Representation of the Digitized Measured Value for the Analog Input Function (Voltage and Current Measuring Range) .. | 13-51 |
| 13-44 | Representation of the Analog Output Ranges (Voltage and Current Output Ranges) | 13-52 |
| 13-45 | X1 Socket, IF 964-DP (9-Pin Sub D Connector) | 13-63 |
| A-1 | SFCs for assigning Parameters to Signal Modules | A-2 |
| A-2 | Parameters of the Digital Input Modules | A-4 |
| A-3 | Parameters of the Digital Output Modules | A-7 |
| A-4 | Parameters of the Analog Input Modules | A-10 |
| B-1 | Codes of the Module Types | B-3 |

General Technical Specifications

1

What are General Technical Specifications?

General technical specifications include the following:

- The standards and test specifications complied with and met by the modules of the S7-400/M7-400 programmable controllers
- The test criteria against which the S7-400/M7-400 modules were tested

Chapter Overview

| Section | Description | Page |
|---------|--|------|
| 1.1 | Standards and Approvals | 1-2 |
| 1.2 | Electromagnetic Compatibility | 1-9 |
| 1.3 | Shipping and Storage Conditions for Modules and Backup Batteries | 1-12 |
| 1.4 | Mechanical and Ambient Climatic Conditions for Operating the S7-400/M7-400 | 1-14 |
| 1.5 | Information on Insulation Tests, Protection Class and Degree of Protection | 1-18 |
| 1.6 | Using S7-400 in a zone 2 explosion–risk area | 1-19 |

1.1 Standards and Approvals

Note

You will find the current approvals on the identification label of the respective products.

IEC 61131-2

The S7-400/M7-400 programmable controller satisfies the requirements and criteria of the IEC 61131-2 standard (programmable controllers, part 2 on equipment requirements and tests).

CE Mark



Our products satisfy the requirements and protection objectives of the EC Directives listed below and comply with the harmonized European standards (EN) promulgated in the Official Journals of the European Community for programmable controllers:

- 73/23/EEC “Electrical Equipment Designed for Use between Certain Voltage Limits” (Low-Voltage Directive)
- 89/336/EEC “Electromagnetic Compatibility” (EMC Directive)
- 94/9/EG “Devices and protection systems to be used as prescribed in potentially explosive areas (Guidelines for Explosion Protection)”

The declarations of conformity are held at the disposal of the competent authorities at the address below:

Siemens Aktiengesellschaft
Bereich Automation and Drives
A&D AS RD 42
Postfach 1963
D-92209 Amberg

EMC Directive

SIMATIC products have been designed for use in industrial environments.

Table 1-1 Use in an Industrial Environment

| EMC Directive | Requirements in respect of: | |
|---------------|-----------------------------|--------------------|
| | Emitted interference | Immunity |
| Industry | EN 61000-6-4 : 001 | EN 61000-6-2 : 001 |

Low Voltage Directive

The products listed in the table below fulfill the requirements of EU low-voltage directive (73/23/EEC). Adherence to this EU directive was tested in accordance with IEC 61131-2.

Table 1-2 Products that Fulfill the Requirements of the Low-Voltage Directive

| Name | Order number |
|---|--|
| Digital Input Module SM 421; DI 32 x 120 VUC | 6ES7421-1EL00-0AA0 |
| Digital Input Module SM 421; DI 16 x 120/230 VUC | 6ES7421-1FH00-0AA0 |
| Digital Output Module SM 422; DO 8 x 120/230 VAC/5 A | 6ES7422-1FF00-0AA0 |
| Digital Output Module SM 422; DO 16 x 120/230 VAC/2 A | 6ES7422-1FH00-0AB0 |
| Relay Output Module SM 422; DO 16 x 30/230 VUC/Rel5A | 6ES7422-1HH00-0AA0 |
| Digital input module SM 421; DI 16 x UC 120/230 V | 6ES7421-1FH20-0AA0 |
| The 120/230 VAC Fan Subassembly | 6ES7408-1TB00-0XA0 |
| PS 407 4A | 6ES7407-0DA00-0AA0 6ES7407-0DA01-0AA0 |
| PS 407 10A | 6ES7407-0KA00-0AA0 6ES7407-0KA01-0AA0 |
| PS 407 20A | 6ES7407-0RA00-0AA0 6ES7407-0RA01-0AA0 |
| PS 407 10AR | 6ES7407-0KR00-0AA0 |

Note

In the new releases, some of the devices listed above fulfil the requirements of the explosion protection guidelines instead of that of the low-voltage directive. Please note the information on the identification label.

Explosion Protection Guidelines



According to EN 50021 (Electrical apparatus for potentially explosive atmospheres; Type of protection “n”)



II 3 G EEx nA II T3..T6

Mark for Australia and New Zealand



Our products satisfy the requirements of Standard AS/NZS 2064 (Class A).

Note

You will recognize the approval assigned to your product from the mark on the identification label. The approvals are listed below UL/CSA or cULus.

UL Approval



UL recognition mark

Underwriters Laboratories (UL) to the UL 508 Standard:

- Report E 85972
- Report 143289 for the modules in Table 1-3

CSA Approval



CSA certification mark

Canadian Standard Association (CSA) to Standard C 22.2 No. 142:

- Certification Record 212191-0-000
- Report 111 879 for the modules in Table 1-3

or

cULus Approval

Underwriters Laboratories Inc. nach



- UL 508 (Industrial Control Equipment)
- CSA C22.2 No. 142 (Process Control Equipment)

or
cULus Approval, Hazardous Location



CULUS Listed 7RA9 INT. CONT. EQ. FOR HAZ. LOC.

Underwriters Laboratories Inc. nach

HAZ. LOC.

- UL 508 (Industrial Control Equipment)
- CSA C22.2 No. 142 (Process Control Equipment)
- UL 1604 (Hazardous Location)
- CSA-213 (Hazardous Location)

APPROVED for Use in

- Cl. 1, Div. 2, GP. A, B, C, D T4A
- Cl. 1, Zone 2, GP. IIC T4

Please read the notes below.

or
cULus Approvals, Hazardous Location for Relay Modules



CULUS Listed 7RA9 INT. CONT. EQ. FOR HAZ. LOC.

Underwriters Laboratories Inc. nach

HAZ. LOC.

- UL 508 (Industrial Control Equipment)
- CSA C22.2 No. 142 (Process Control Equipment)
- UL 1604 (Hazardous Location)
- CSA-213 (Hazardous Location)

APPROVED for Use in

- Cl. 1, Div. 2, GP. A, B, C, D T4A
- Cl. 1, Zone 2, AEx nC IIC T4
- Cl. 1, Zone 2, Ex nC IIC T4

Please read the notes below.

Note

This plant has to be mounted according to the NEC (National Electric Code) stipulations.

When used in environments according to class I, division 2 (see above) , S7-400 must be mounted in a housing that corresponds to at least IP54 according to EN 60529.

cuULu requirements on hazardous location on the battery power supply for CPUs

The power supply to the backup battery of a CPU must be via a non-incendive plug. The figure below portrays the concept of such connection.

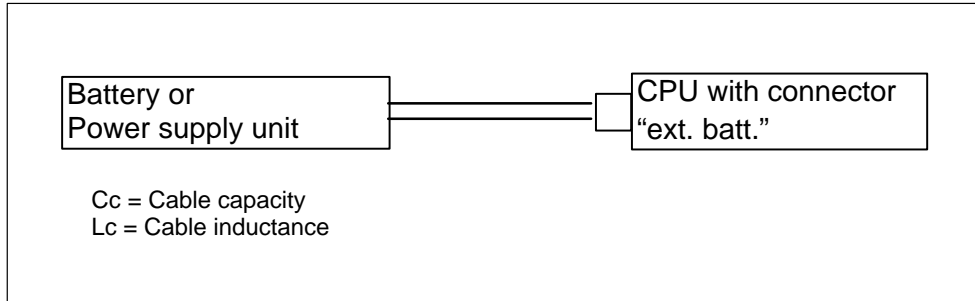

Figure 1-1 Power supply to the backup battery

The following conditions apply to the performance characteristics of this connection:

- | | |
|--|--------------------|
| Voc (no load voltage) = 15V | Vmax = 15V |
| Isc (short-circuit current) = 50 mA | Imax = 50 mA |
| Ca = Battery capacity/ power supply | Ci = 25 nF maximum |
| La = Battery inductance/ power supply | Li = 2 mH maximum |

The battery/power supply which supplies the non-ingnitable connection must have the following values:

| Battery/Power supply | | CPU input "Ext. Batt." incl. cabel |
|----------------------|---|------------------------------------|
| Voc | ≤ | Vmax (15V) |
| Isc | ≤ | Imax (50 mA) |

| Battery/Power supply | | CPU input "Ext. Batt." incl. cable |
|----------------------|--------|------------------------------------|
| Ca | \geq | $C_i + C_c (25\text{nF} + C_c)$ |
| La | \geq | $L_i + L_c (2\text{mH} + L_c)$ |

The batteries used must have the following properties:

- Battery technology: Li/SOCL2
- Model: AA
- Voltage: 3.6 V

The batteries stipulated by Siemens fulfil requirements that go beyond the ones mentioned above.

You may only use batteries approved by Siemens !

Note

If you do not know the capacity and inductance of the cable, you can use the following values:

$C_c = 197 \text{ pF/m (60 pF/ft.)}$, $L_c = 0.66 \text{ pF/m (0.2 mH/ft)}$

Example

The battery of type 4022 from Varta together with a 1.5 m long cable and a plug connection of type 02–02.1500 from Leonhardy meet these conditions.

FM Approval



Factory Mutual Approval Standard Class Number 3611, Class I, Division 2, Group A, B, C, D.

Temperature class: T4 at 60 °C ambient temperature

Exception:

The following applies to the power supply modules in Table 1-3:

- Temperature class T3C at 60 °C ambient temperature
- Temperature class T4 at 40 °C ambient temperature

In the case of the modules in Table 1-3 the T4 temperature class is achieved for the whole system if the ambient temperature does not exceed 40 °C during operation. There are also certain additional requirements that you can comply with by installing the system in cabinets.

Table 1-3 Power Supply Modules

| Name | Order number |
|---------------------------------|---------------------|
| PS 407 4 A Power Supply Module | 6ES7 407-0DA00-0AA0 |
| PS 407 10 A Power Supply Module | 6ES7 407-0KA00-0AA0 |
| PS 407 20 A Power Supply Module | 6ES7 407-0RA00-0AA0 |
| PS 405 4 A Power Supply Module | 6ES7 405-0DA00-0AA0 |
| PS 405 10 A Power Supply Module | 6ES7 405-0KA00-0AA0 |
| PS 405 20 A Power Supply Module | 6ES7 405-0RA00-0AA0 |



Warning

Personal injury or property damage can result.

In hazardous areas, personal injury or property damage can result if you create or break an electrical circuit during operation of an S7-400/M7-400 (for example, by means of plug-in connections, fuses, switches).

Do not create or break live electric circuits unless you are certain there is no danger of explosion.

If you use S7-400 under FM conditions, it has to be mounted in a housing, which at least corresponds to IP54 in accordance with EN 60529.

Safety Requirements for Installation

The S7-400/M7-400 programmable controllers are “open type” equipment to the IEC 61131-2 standard and therefore adhere to the EU directive 73/23/EEC “Low-Voltage Directive” and are UL/CSA certified as such.

To fulfill requirements for safe operation with regard to mechanical stability, flame retardance, stability, and shock-hazard protection, the following alternative types of installation are specified:

- Installation in a suitable cabinet
- Installation in a suitable housing
- Installation in a suitably equipped, enclosed operating area.

1.2 Electromagnetic Compatibility

Introduction

In this section you will find information on the noise immunity of S7-400/M7-400 modules and on radio interference suppression.

All the components of S7-400/M7-400 systems meet the requirements of the standards that apply in Europe provided they are installed in accordance with all the appropriate regulations (see *Installation Manual*, Chapters 2 and 4).

Definition of “EMC”

Electromagnetic compatibility (EMC) is the ability of an electrical installation to function satisfactorily in its electromagnetic environment without interfering with that environment.



Warning

Personal injury or property damage can result.

Installation of expansions that have not been approved for the S7-400/M7-400 can result in violations of the requirements and regulations for safety and electromagnetic compatibility.

Use only expansions that have been approved for the system.

Pulse-Shaped Interference

The following table shows the electromagnetic compatibility of modules when there are pulse-shaped disturbance variables. A requirement for this is that the S7-400/M7-400 system complies with the relevant requirements and guidelines on electric design.

Table 1-4 Pulse-Shaped Interference

| Pulse-Shaped Interference | Test Voltage | Degree of Severity |
|---|--|--------------------|
| Electrostatic discharge To IEC 61000-4-2 | Discharge to air: ±8 kV Contact discharge: ±6 kV | 3 |
| Bursts (fast transient interference in accordance with IEC 61000-4-4) | 2 kV (power supply line) 2 kV (signal line > 30 m) 1 kV (signal line < 30 m) | 3 |
| Energy-rich single impulse (surge) to IEC 61000-4-5 <ul style="list-style-type: none"> • Asymmetrical coupling • Symmetrical coupling | 2 kV (supply line) DC voltage with protective elements 2 kV (signal line/data line > 30 m only), possibly with protective elements 1 kV (supply line) DC voltage with protective elements 1 kV (signal line > 30 m only), possibly with protective elements | 3 |

Sinusoidal Interference

The following table shows you the EMC behavior of the S7-400/M7-400 modules when there is sinusoidal interference.

Table 1-5 Sinusoidal Interference

| Sinusoidal Interference | Test Values | Degree of Severity |
|---|---|--------------------|
| RF irradiation (electromagnetic fields) To IEC 61000-4-3 To IEC 61000-4-3 | 10 V/m with 80% amplitude modulation of 1 kHz over the range from 80 MHz to 1000 MHz 10 V/m with 50% pulse modulation at 900 MHz | 3 |
| RF conductance on cables and cable shields to IEC 61000-4-6 | Test voltage 10 V with 80% amplitude modulation of 1 kHz over the range from 9 MHz to 80 MHz | 3 |

Emission of Radio Interference

Interference emission of electromagnetic fields in accordance with EN 55011: Limit value class A, Group 1.

Table 1-6 Interference emission of electromagnet fields

| Frequency Range | Limit Value |
|---|-----------------------------------|
| From 20 to 230 MHz | 30 dB ($\mu\text{V}/\text{m}$)Q |
| From 230 to 1000 MHz | 37 dB ($\mu\text{V}/\text{m}$)Q |
| Measured at a distance of 30 m (98.4 ft.) | |

Emitted interference via the mains AC power supply in accordance with EN 55011: Limit value class A, group 1.

Table 1-7 Interference emission via the mains AC power supply

| Frequency Range | Limit Value |
|----------------------|--------------------------|
| From 0.15 to 0.5 MHz | 79 dB (μV)Q |
| | 66 dB (μV)M |
| From 0.5 to 5 MHz | 73 dB (μV)Q |
| | 60 dB (μV)M |
| From 5 to 30 MHz | 73 dB (μV)Q |
| | 60 dB (μV)M |

System Perturbation

The products listed in the table below fulfill the requirements of the following standards for system perturbation:

| | |
|-------------------------------------|--------------|
| Harmonic currents: | EN 61000-3-2 |
| Voltage fluctuations and flickering | EN 61000-3-3 |

Table 1-8 Power Supply Modules that Comply with System Perturbation Standards

| Name | Order Number |
|--|--------------------|
| PS 407 4 A Power Supply Module | 6ES7407-0DA01-0AA0 |
| PS 407 10 A Power Supply Module | 6ES7407-0KA01-0AA0 |
| PS 407R 10 A Redundant Power Supply Module | 6ES7422-0KR00-0AA0 |
| PS 407 20 A Power Supply Module | 6ES7407-0RA01-0AA0 |

Additional Measures

If you want to connect an S7-400 or M7-400 system to the public power system, you must ensure compliance with **limit value class B in accordance with EN 55022**.

Suitable additional measures must be taken, if you need to enhance the noise immunity of the system as a result of high external noise levels.

1.3 Shipping and Storage Conditions for Modules and Backup Batteries

Shipping and Storage of Modules

S7-400/M7-400 modules surpass the requirements of IEC 61131-2 in respect of shipping and storage requirements. The following details apply to modules shipped and/or stored in their original packing.

The climatic conditions conform to IEC 60721, Part 3-3, Class 3K7 for storage and IEC 60721, Part 3-2, Class 2K4 for transport.

The mechanical conditions conform to IEC 60721, Part 3-2, Class 2M2.

Table 1-9 Shipping and Storage Conditions for Modules

| | Permitted Range |
|--|--|
| Free fall | ≤ 1 m (up to 10 kg) |
| Temperature | −40 °C to +70 °C |
| Atmospheric pressure | 1080 to 660 hPa (corresponds to a height of -1000 to 3500 m) |
| Relative humidity (at +25 °C) | 5 to 95 %, without condensation |
| Sinusoidal oscillations to IEC 60068-2-6 | 5 to 9 Hz: 3.5 mm 9 to 500 Hz: 9.8 m/s ² |
| Shock to IEC 60068-2-29 | 250 m/s ² , 6 ms, 1000 shocks |

Shipping of Backup Batteries

Wherever possible, transport backup batteries in their original packing. No special measures are required for the transport of the backup batteries used in the S7-400/M7-400 systems. The lithium component of the backup battery is less than 0.5 g.

Storing Backup Batteries

Backup batteries must be stored in a cool, dry place. The maximum storage time is 10 years.



Warning

Improper handling of backup batteries can cause injury and material damage. If backup batteries are not treated properly, they can explode and cause severe burning.

Please observe the following rules when handling backup batteries used in the S7-400/M7-400 programmable controllers:

- never charge them
 - never heat them
 - never throw them in the fire
 - never damage them mechanically (drill, squeeze, etc.)
-

1.4 Mechanical and Ambient Climatic Conditions for Operating the S7-400/M7-400

Operating Conditions

The S7-400/M7-400 is designed for weather-protected use as a permanent installation. The S7-400/M7-400 fulfills the requirements for use in accordance with IEC 60721-3-3:

- Class 3M3 (mechanical requirements)
- Class 3K3 (ambient climatic conditions)

Use with Additional Measures

The S7-400/M7-400, for example, must **not** be used without taking additional measures:

- In locations exposed to a high degree of ionizing radiation
- In hostile environments caused, for instance, by
 - Dust accumulation
 - Corrosive vapors or gases
 - Strong electric or magnetic fields
- In installations requiring special monitoring, for example
 - Elevators
 - Electrical installations in particularly hazardous areas

An additional measure might be, for instance, installation of the S7-400/M7-400 in a cabinet or in a housing.

Ambient Mechanical Conditions

The ambient mechanical conditions for S7-400/M7-400 modules are listed in the following table in the form of sinusoidal oscillations.

Table 1-10 Mechanical Conditions

| Frequency Range in Hz | Test Values |
|-----------------------|---------------------------|
| $10 \leq f < 58$ | 0.075 mm amplitude |
| $58 \leq f < 500$ | 1 g constant acceleration |

Table 1-11 Ambient Mechanical Conditions for the MSM 478 Mass Storage Module in Operation

| Frequency Range in Hz | Test Values |
|-----------------------------|---|
| 10 ≤ f < 58 58 ≤ f < 500 | 0.035 mm amplitude 0.5 g constant acceleration |
| Shock | Semi-sinusoidal 5 g, 11 ms |

Reducing Vibrations

If the S7-400/M7-400 is subject to high levels of shock or vibration, you must take suitable measures to reduce the acceleration or amplitude.

We recommend that you install the S7-400/M7-400 on vibration-damping materials (for example, rubber-metal antivibration mountings).

Tests for Ambient Mechanical Conditions

The following table contains important information on the type and scope of tests for ambient mechanical conditions.

Table 1-12 Ambient Mechanical Conditions Test

| Test ... | Test Standard | Remarks |
|------------|--|---|
| Vibrations | Vibration test in accordance with IEC 60068-2-6 (sinusoidal) | Type of oscillation: frequency sweeps with a rate of change of 1 octave/minute. 10 Hz ≤ f < 58 Hz, constant amplitude 0.075 mm 58 Hz ≤ f < 500 Hz, constant acceleration 1 g Duration of oscillation: 10 frequency sweeps per axis in each of three axes perpendicular to each other |
| Shock | Shock test in accordance with IEC 60068-2-29 | Type of shock: half-sine Severity of shock: 10 g peak value, 6 ms duration Direction of shock: 100 shocks in each of the 3 axes arranged vertically to each other |

Ambient Climatic Conditions for the S7-400

You can use the S7-400 under the following ambient climatic conditions:

Table 1-13 Ambient Climatic Conditions for the S7-400

| Climatic Conditions | Permitted Range | Remark |
|---------------------|-----------------|--------|
| Temperature | 0 to +60 °C | |
| Temperature change | Max. 10 °C/h | |

Table 1-13 Ambient Climatic Conditions for the S7-400

| Climatic Conditions | Permitted Range | Remark |
|-------------------------------|--|---|
| Relative humidity | Max. 95 % at +25 °C | No condensation, corresponds to RH stressing level 2 in accordance with IEC 61131-2 |
| Atmospheric pressure | 1080 to 795 hPa (corresponds to a height of -1000 to 2000 m) | The power supply modules in Table 1-12 achieve the following values: 1080 to 869 hPa (corresponds to a level of -1000 to 1500 m) |
| Concentration of contaminants | SO ₂ : < 0.5 ppm; RH < 60 %, no condensation H ₂ S: < 0.1 ppm; RH < 60 %, no condensation | Test: 10 ppm; 4 days Test: 1 ppm; 4 days |

Table 1-14 Power Supply Modules for Use at up to + 1500 m

| Name | Order number |
|--------------------------------|--------------------|
| Power supply module PS 407 4A | 6ES7407-0DA00-0AA0 |
| Power supply module PS 407 10A | 6ES7407-0KA00-0AA0 |
| Power supply module PS 407 20A | 6ES7407-0RA00-0AA0 |
| Power supply module PS 405 4A | 6ES7405-0DA00-0AA0 |
| Power supply module PS 405 10A | 6ES7405-0KA00-0AA0 |
| Power supply module PS 405 20A | 6ES7405-0RA00-0AA0 |

Ambient Climatic Conditions for the M7-400

The M7-400 may be used under the following ambient climatic conditions:

Table 1-15 Ambient Climatic Conditions for the M7-400

| Climatic Conditions | Permitted Range | Remark |
|-------------------------------|--|--|
| Temperature | 0 to +60 °C 5 to +55 °C 5 to +40 °C | When using a CPU 486-3 or 488-3 When using an MSM 478 without diskette operation but with ventilation When using an MSM 478 with diskette operation or without ventilation (when using an ATM 478, the permissible temperature range is restricted by the AT module used) |
| Relative humidity | Max. 95 % | No condensation, corresponds to RH stressing level 2 in accordance with IEC 61131-2 |
| Atmospheric pressure | 1080 to 795 kPa (corresponds to a height of -1000 to 2000 m) | Note the restriction on the power supply in Table 1-12. |
| Concentration of contaminants | SO ₂ : < 0.5 ppm; RH < 60 %, no condensation) H ₂ S: < 0.1 ppm; RH < 60 %, no condensation) | Test: 10 ppm; 4 days 1 ppm; 4 days |

1.5 Information on Insulation Tests, Protection Class and Degree of Protection

Test Voltages

Insulation resistance was demonstrated in routine testing with the following test voltages in accordance with IEC 61131-2:

Table 1-16 Test Voltages

| Circuits with Rated Voltage U_e to Other Circuits or Ground | Test Voltage |
|---|--------------|
| $0 \text{ V} < U_e \leq 50 \text{ V}$ | 350 V |
| $50 \text{ V} < U_e \leq 100 \text{ V}$ | 700 V |
| $100 \text{ V} < U_e \leq 150 \text{ V}$ | 1300 V |
| $150 \text{ V} < U_e \leq 300 \text{ V}$ | 2200 V |

Protection Class

Safety class I to IEC 60536 (VDE 0106, Part 1). In other words, a connection is required from the protective conductor to the power supply module.

Protection Against Ingress of Foreign Bodies and Water

Degree of protection IP 20 to IEC 60529. In other words, there is protection against contact with standard probes.

There is no special protection against the ingress of water.

1.6 Using S7-400 in a zone 2 explosion–risk area

You will find important information in different languages in the chapters below.

Chapter overview

| Chapter | Thema |
|---------|---|
| 1.6.1 | Einsatz der S7-400 im explosionsgefährdeten Bereich Zone 2 |
| 1.6.2 | Use of the S7-400 in a Zone 2 Hazardous Area |
| 1.6.3 | Utilisation de la S7-400 dans un environnement à risque d'explosion en zone 2 |
| 1.6.4 | Aplicación del S7-400 en áreas con peligro de explosión, zona 2 |
| 1.6.5 | Impiego dell' S7-400 nell'area a pericolo di esplosione zona 2 |
| 1.6.6 | Gebruik van de S7-400 in het explosieve gebied zone 2 |
| 1.6.7 | Brug af S7-400 i det explosionsfarlige område zone 2 |
| 1.6.8 | S7-400:n käyttö räjähdysvaarannetuilla alueilla, vyöhyke 2 |
| 1.6.9 | Användning av S7-400 i explosionsriskområde zon 2 |
| 1.6.10 | Uso do S7-400 em área exposta ao perigo de explosão, zona 2 |
| 1.6.11 | Χρήση της συσκευής S7-400 σε ... |

1.6.1 Einsatz der S7-400 im explosionsgefährdeten Bereich Zone 2

Zone 2

Explosionsgefährdete Bereiche werden in Zonen eingeteilt. Die Zonen werden nach der Wahrscheinlichkeit des Vorhandenseins einer explosionsfähigen Atmosphäre unterschieden.

| Zone | Explosionsgefahr | Beispiel |
|------------------|---|---|
| 2 | explosive Gasatmosphäre tritt nur selten und kurzzeitig auf | Bereiche um Flanschverbindungen mit Flachdichtungen bei Rohrleitungen in geschlossenen Räumen |
| sicherer Bereich | nein | <ul style="list-style-type: none">• außerhalb der Zone 2• Standardanwendungen von dezentraler Peripherie |

Nachfolgend finden Sie wichtige Hinweise für die Installation der SIMATIC S7-400 im explosionsgefährdeten Bereich.

Weitere Informationen

Weitere Informationen zu den verschiedenen S7-400-Baugruppen finden Sie im Handbuch.

Fertigungsort

Siemens AG, Bereich A&D
Östliche Rheinbrückenstraße 50
76187 Karlsruhe
Germany

Zulassung

 II 3 G EEx nA II T3 .. T6 nach EN 50021 : 1999
Prüfnummer: **KEMA 03ATEX1125 X**

Hinweis

Baugruppen mit der Zulassung  II 3 G EEx nA II T3 .. T6 dürfen nur in Automatisierungssystemen SIMATIC S7-400 der Gerätekategorie 3 eingesetzt werden.

Instandhaltung

Für eine Reparatur muss die betroffene Baugruppe an den Fertigungsort geschickt werden. Nur dort darf die Reparatur durchgeführt werden.

Besondere Bedingungen

1. Die SIMATIC S7-400 muss in einen Schaltschrank oder ein metallisches Gehäuse eingebaut werden. Diese müssen mindestens die Schutzart IP 54 (nach EN 60529) gewährleisten. Dabei sind die Umgebungsbedingungen zu berücksichtigen, in denen das Gerät installiert wird. Für das Gehäuse muss eine Herstellererklärung für Zone 2 vorliegen (gemäß EN 50021).
2. Wenn am Kabel bzw. an der Kabeleinführung dieses Gehäuses unter Betriebsbedingungen eine Temperatur $> 70\text{ °C}$ erreicht wird oder wenn unter Betriebsbedingungen die Temperatur an der Aderverzweigung $> 80\text{ °C}$ sein kann, müssen die Temperatureigenschaften der Kabel mit den tatsächlich gemessenen Temperaturen übereinstimmen.
3. Die eingesetzten Kabeleinführungen müssen der geforderten IP-Schutzart und dem Abschnitt 7.2 (gemäß EN 50021) entsprechen.
4. Alle Geräte, einschließlich Schalter etc., die an den Ein- und Ausgängen von S7-400-Systemen angeschlossen werden, müssen für den Explosionsschutz Typ EEx nA oder EEx nC genehmigt sein.
5. Es müssen Maßnahmen getroffen werden, dass die Nennspannung durch Transienten um nicht mehr als 40 % überschritten werden kann.
6. Umgebungstemperaturbereich: 0 °C bis 60 °C
7. Innerhalb des Gehäuses ist an einem nach dem Öffnen gut sichtbaren Platz ein Schild mit folgender Warnung anzubringen:

Warnung

Das Gehäuse darf nur kurze Zeit geöffnet werden, z. B. für visuelle Diagnose. Betätigen Sie dabei keine Schalter, ziehen oder stecken keine Baugruppen und trennen keine elektrischen Leitungen (Steckverbindungen).

Diese Warnung kann unberücksichtigt bleiben, wenn bekannt ist, dass keine explosionsgefährdete Atmosphäre herrscht.

Liste der zugelassenen Baugruppen

Die Liste mit den zugelassenen Baugruppen finden Sie im Internet:

<http://www4.ad.siemens.de/view/cs/>

unter der Beitrags-ID 13702947

1.6.2 Use of the S7-400 in a Zone 2 Hazardous Area

Zone 2

Hazardous areas are divided up into zones. The zones are distinguished according to the probability of the existence of an explosive atmosphere.

| Zone | Explosion Hazard | Example |
|-----------|--|--|
| 2 | Explosive gas atmosphere occurs only seldom and for a short time | Areas around flange joints with flat gaskets in pipes in enclosed spaces |
| Safe area | No | <ul style="list-style-type: none">• Outside zone 2• Standard distributed I/O applications |

Below you will find important information on the installation of the SIMATIC S7-400 in a hazardous area.

Further Information

You will find further information on the various S7-400 modules in the manual.

Production Location

Siemens AG, Bereich A&D
Östliche Rheinbrückenstraße 50
76187 Karlsruhe
Germany

Certification

 II 3 G EEx nA II T3 .. T6 in accordance with EN 50021 : 1999

Test number: **KEMA 03ATEX1125 X**

Note

Modules with  II 3 G EEx nA II T3 .. T6 certification can only be used in SIMATIC S7-400 automation systems belonging to equipment category 3.

Maintenance

If repair is necessary, the affected module must be sent to the production location. Repairs can only be carried out there.

Special Conditions

1. The SIMATIC S7-400 must be installed in a cabinet or metal housing. These must comply with the IP 54 (in accordance with EN 60529) degree of protection as a minimum. The environmental conditions under which the equipment is installed must be taken into account. There must be a manufacturer's declaration for zone 2 available for the housing (in accordance with EN 50021).
2. If a temperature of $> 70\text{ }^{\circ}\text{C}$ is reached in the cable or at the cable entry of this housing under operating conditions, or if a temperature of $> 80\text{ }^{\circ}\text{C}$ can be reached at the junction of the conductors under operating conditions, the temperature-related properties of the cables must correspond to the temperatures actually measured.
3. The cable entries used must comply with the required IP degree of protection and Section 7.2 (in accordance with EN 50021).
4. All devices (including switches, etc.) that are connected to the inputs and outputs of S7-400 systems must be approved for EEx nA or EEx nC explosion protection.
5. Steps must be taken to ensure that the rated voltage through transients cannot be exceeded by more than 40 %.
6. Ambient temperature range: 0°C to 60°C
7. A sign containing the following warning must be put up inside the housing in an easily visible position when the housing is opened:

Warning

The housing can only be opened for a short time (e.g. for visual diagnostics). If you do this, do not operate any switches, remove or install any modules or disconnect any electrical cables (plug-in connections).

You can disregard this warning if you know that the atmosphere is not hazardous (i.e. there is no risk of explosion).

List of Approved Modules

You will find the list of approved modules under the ID 13702947 on the Internet:

<http://www4.ad.siemens.de/view/cs/>.

1.6.3 Utilisation du S7-400 dans un environnement à risque d'explosion en zone 2

Zone 2

Les environnements à risque d'explosion sont répartis en zones. Les zones se distinguent par la probabilité de présence d'une atmosphère explosive.

| Zone | Risque d'explosion | Exemple |
|-----------|--|---|
| 2 | Formation rare et brève d'une atmosphère gazeuse explosive | Environnement de raccords à joints plats dans le cas de conduites dans des locaux fermés |
| Zone sûre | Non | <ul style="list-style-type: none">• A l'extérieur de la zone 2• Utilisation standard de périphérie décentralisée |

Vous trouverez ci-après des remarques importantes pour l'installation du SIMATIC S7-400 dans un environnement présentant un risque d'explosion.

Informations complémentaires

Des informations complémentaires sur les divers modules S7-400 se trouvent dans le manuel.

Lieu de production

Siemens AG, Bereich A&D
Östliche Rheinbrückenstraße 50
76187 Karlsruhe
Germany

Homologation

 II 3 G EEx nA II T3 .. T6 selon EN 50021 : 1999

Numéro de contrôle : **KEMA 03ATEX1125 X**

Nota

Les modules homologués  II 3 G EEx nA II T3 .. T6 ne peuvent être utilisés que dans des automates SIMATIC S7-400 de catégorie 3.

Entretien

Si une réparation est nécessaire, le module concerné doit être expédié au lieu de production. La réparation ne doit être effectuée qu'en ce lieu.

Conditions particulières

1. Le SIMATIC S7-400 doit être installé dans une armoire ou un boîtier métallique. Ceux-ci doivent assurer au moins l'indice de protection IP 54. Il faut alors tenir compte des conditions d'environnement dans lesquelles l'appareil est installé. Le boîtier doit faire l'objet d'une déclaration de conformité du fabricant pour la zone 2 (selon EN 50021).
2. Si dans les conditions d'exploitation, une température > 70 °C est atteinte au niveau du câble ou de l'entrée du câble dans ce boîtier, ou bien si la température au niveau de la dérivation des conducteurs peut être > 80 °C, les capacités de résistance thermique des câbles doivent correspondre aux températures effectivement mesurées.
3. Les entrées de câbles utilisées doivent avoir le niveau de protection IP exigé et être conformes au paragraphe 7.2 (selon EN 50021).
4. Tous les appareillages (y compris les interrupteurs, etc.) raccordés aux entrées et sorties de modules de signaux à sécurité intrinsèque doivent être homologués pour la protection antidéflagrante type EEx nA ou EEx nC.
5. Il faut prendre des mesures pour que la tension nominale ne puisse pas être dépassée de plus de 40% sous l'influence de transitoires.
6. Plage de température ambiante : 0° C à 60° C
7. A l'intérieur du boîtier, il faut placer, à un endroit bien visible après ouverture, une plaquette comportant l'avertissement suivant :
Avertissement
Ouvrir le boîtier le moins longtemps possible, par exemple pour effectuer un diagnostic visuel. Ce faisant, n'actionnez aucun commutateur, ne déconnectez aucun module et ne débanchez pas de câbles électriques (connexions).
Le respect de cet avertissement n'est pas impératif s'il est certain que l'environnement ne présente pas de risque d'explosion.

Liste des modules homologués

Vous trouverez sur Internet la liste des modules homologués :

<http://www4.ad.siemens.de/view/cs/>

référence ID 13702947

1.6.4 Aplicación de la S7-400 en áreas con peligro de explosión, zona 2

Zona 2

Las áreas con peligro de explosión se clasifican en zonas. Las zonas se diferencian según la probabilidad de la existencia de una atmósfera capaz de sufrir una explosión.

| Zona | Peligro de explosión | Ejemplo |
|-------------|--|--|
| 2 | La atmósfera explosiva de gas sólo se presenta rara vez y muy brevemente | Áreas alrededor de uniones abridadas con juntas planas en tuberías en locales cerrados |
| Área segura | No | <ul style="list-style-type: none">Fuera de la zona 2Aplicaciones estándar de la periferia descentralizada |

A continuación encontrará importantes informaciones para la instalación del SIMATIC S7-400 en áreas con peligro de explosión.

Otras informaciones

Encontrará otras informaciones relativas a los distintos módulos S7-400 en el Manual.

Lugar de fabricación

Siemens AG, Bereich A&D
Östliche Rheinbrückenstraße 50
76187 Karlsruhe
Germany

Homologación

 II 3 G EEx nA II T3 .. T6 según norma EN 50021 : 1999

Número de comprobación: **KEMA 03ATEX1125 X**

Nota

Los módulos con la homologación  II 3 G EEx nA II T3 .. T6 pueden utilizarse únicamente en los autómatas programables SIMATIC S7-400 de la categoría de equipo 3.

Mantenimiento

Para una reparación se ha de remitir el módulo afectado al lugar de fabricación. Sólo allí se puede realizar la reparación.

Condiciones especiales

1. El SIMATIC S7-400 se ha de montar en un armario eléctrico de distribución o en una carcasa metálica. Éstos deben garantizar como mínimo el grado de protección IP 54 (conforme a EN 60529). Para ello se han de tener en cuenta las condiciones ambientales, en las cuales se instala el equipo. La caja deberá contar con una declaración del fabricante para la zona 2 (conforme a EN 50021).
2. Si durante la operación se alcanzara una temperatura $> 70^{\circ}\text{C}$ en el cable o la entrada de cables de esta caja o bien una temperatura $> 80^{\circ}\text{C}$ en la bifurcación de hilos, deberán adaptarse las propiedades térmicas de los cables a las temperaturas medidas efectivamente.
3. Las entradas de cable utilizadas deben cumplir el grado de protección IP exigido y lo expuesto en el apartado 7.2 (conforme a EN 50021).
4. Todos los dispositivos –inclusive interruptores, etc.– conectados a las entradas y salidas sistemas S7-400 deben estar homologados para la protección contra explosiones del tipo EEx nA o EEx nC.
5. Es necesario adoptar las medidas necesarias para evitar que la tensión nominal se pueda rebasar en más del 40 % debido a efectos transitorios.
6. Margen de temperatura ambiente: 0°C hasta 60°C
7. Dentro de la caja deberá colocarse en un lugar perfectamente visible tras su apertura un rótulo con la siguiente advertencia:

Precaución

Abrir la caja sólo brevemente, p.ej. para el diagnóstico visual. Durante este tiempo Ud. no deberá activar ningún interruptor, desenchufar o enchufar módulos ni separar conductores eléctricos (conexiones enchufables). Esta advertencia puede ignorarse si Ud. sabe que en la atmósfera existente no hay peligro de explosión.

Lista de los módulos homologados

En internet hallará Ud. una lista con los módulos homologados:

<http://www4.ad.siemens.de/view/cs/>

bajo el ID de asignación 13702947

1.6.5 Impiego dell'S7-400 nell'area a pericolo di esplosione zona 2

Zona 2

Le aree a pericolo di esplosione vengono suddivise in zone. Le zone vengono distinte secondo la probabilità della presenza di un'atmosfera esplosiva.

| Zona | Pericolo di esplosione | Esempio |
|-------------|---|--|
| 2 | L'atmosfera esplosiva si presenta solo raramente e brevemente | Aree intorno a collegamenti a flange con guarnizioni piatte nelle condotte in ambienti chiusi |
| Area sicura | No | <ul style="list-style-type: none">• Al di fuori della zona 2• Applicazioni standard di periferia decentrata |

Qui di seguito sono riportate delle avvertenze importanti per l'installazione del SIMATIC S7-400 nell'area a pericolo di esplosione.

Ulteriori informazioni

Ulteriori informazioni sulle diverse unità S7-400 si trovano nel manuale.

Luogo di produzione

Siemens AG, Bereich A&D
Östliche Rheinbrückenstraße 50
76187 Karlsruhe
Germany

Autorizzazione



II 3 G

EEx nA II T3 .. T6

secondo EN 50021 : 1999

Numero di controllo:

KEMA 03ATEX1125 X

Avvertenza

Le unità con l'autorizzazione II 3 G EEx nA II T3 .. T6 possono essere impiegate solo nei sistemi di controllori programmabili SIMATIC S7-400 della categoria di apparecchiature 3.

Manutenzione

Per una riparazione, l'unità interessata deve essere inviata al luogo di produzione. La riparazione può essere effettuata solo lì.

Condizioni particolari

1. Il SIMATIC S7-400 deve essere montato in un armadio elettrico o in un contenitore metallico. Questi devono assicurare almeno il tipo di protezione IP 54 (secondo EN 60529). In questo caso bisogna tenere conto delle condizioni ambientali nelle quali l'apparecchiatura viene installata. Per il contenitore deve essere presente una dichiarazione del costruttore per la zona 2 (secondo EN 50021).
2. Se nei cavi o nel loro punto di ingresso in questo contenitore viene raggiunta in condizioni di esercizio una temperatura $> 70\text{ °C}$ o se in condizioni di esercizio la temperatura nella derivazione dei fili può essere $> 80\text{ °C}$, le caratteristiche di temperatura dei cavi devono essere conformi alla temperatura effettivamente misurata.
3. Gli ingressi dei cavi usati devono essere conformi al tipo di protezione IP richiesto e alla sezione 7.2 (secondo EN 50021).
4. Tutte le apparecchiature, inclusi interruttori, ecc. che vengono collegati a ingressi/uscite di sistemi S7-400, devono essere stati omologati per la protezione da esplosione tipo EEx nA o EEx nC.
5. Devono essere prese delle misure per evitare che la tensione nominale possa essere superata per più del 40% da parte di transienti.
6. Campo termico ambientale: da 0 °C a 60 °C
7. All'interno del contenitore va apporata, in un luogo ben visibile dopo l'apertura, una targhetta con il seguente avvertimento:

Attenzione

Il contenitore può rimanere aperto solo per breve tempo, ad esempio per una diagnostica a vista. In tal caso non azionare alcun interruttore, non disinnestare o innestare unità e non staccare connessioni elettriche (connettori).

Non è necessario tenere conto di questo avvertimento se è noto che non c'è un'atmosfera a rischio di esplosione.

Elenco delle unità omologate

La lista con le unità omologate si trova in Internet al sito:

<http://www4.ad.siemens.de/view/cs/>

all'ID di voce 13702947

1.6.6 Gebruik van de S7-400 in het explosief gebied zone 2

Zone 2

Explosieve gebieden worden ingedeeld in zones. Bij de zones wordt onderscheiden volgens de waarschijnlijkheid van de aanwezigheid van een explosieve atmosfeer.

| Zone | Explosiegevaar | Voorbeeld |
|---------------|--|--|
| 2 | Een explosieve gasatmosfeer treedt maar zelden op en voor korte duur | Gebieden rond flensverbindingen met pakkingen bij buisleidingen in gesloten vertrekken |
| Veilig gebied | Neen | <ul style="list-style-type: none"> • Buiten de zone 2 • Standaardtoepassingen van decentrale periferie |

Hierna vindt u belangrijke aanwijzingen voor de installatie van de SIMATIC S7-400 in het explosief gebied.

Verdere informatie

In het handboek vindt u verdere informatie over de verschillende S7-400-modulen.

Productieplaats

Siemens AG, Bereich A&D
 Östliche Rheinbrückenstraße 50
 76187 Karlsruhe
 Germany

Vergunning

 II 3 G EEx nA II T3 .. T6 conform EN 50021 : 1999
 Keuringsnummer: **KEMA 03ATEX1125 X**

Opmerking

Modulen met de vergunning  II 3 G EEx nA II T3 .. T6 mogen slechts worden gebruikt in automatiseringssystemen SIMATIC S7-400 van de apparaatcategorie 3.

Instandhouding

Voor een reparatie moet de betreffende module naar de plaats van vervaardiging worden gestuurd. Alleen daar mag de reparatie worden uitgevoerd.

Speciale voorwaarden

1. Het SIMATIC S7-400 moet worden ingebouwd in een schakelkast of in een behuizing van metaal. Deze moeten minstens de veiligheidsgraad IP 54 (volgens EN 60529) waarborgen. Hierbij dient rekening te worden gehouden met de omgevingsvoorwaarden waarin het apparaat wordt geïnstalleerd. Voor de behuizing dient een verklaring van de fabrikant voor zone 2 te worden ingediend (volgens EN 50021).
2. Als aan de kabel of aan de kabelinvoering van deze behuizing onder bedrijfsomstandigheden een temperatuur wordt bereikt $> 70\text{ °C}$ of als onder bedrijfsomstandigheden de temperatuur aan de adervertakking $> 80\text{ °C}$ kan zijn, moeten de temperatuureigenschappen van de kabel overeenstemmen met de werkelijk gemeten temperaturen.
3. De aangebrachte kabelinvoeringen moeten de vereiste IP-veiligheidsgraad hebben en in overeenstemming zijn met alinea 7.2 (volgens EN 50021).
4. Alle apparaten, schakelaars enz. inbegrepen, die worden aangesloten op de in- en uitgangen van S7-400 systemen, moeten zijn goedgekeurd voor de explosiebeveiliging type EEx nA of EEx nC.
5. Er dienen maatregelen te worden getroffen, zodat de nominale spanning door transiënten met niet meer dan 40 % kan worden overschreden.
6. Omgevingstemperatuurbereik: 0 °C tot 60 °C
7. Binnen de behuizing dient op een na het openen goed zichtbare plaats een bord te worden aangebracht met de volgende waarschuwing:

Waarschuwing

De behuizing mag slechts voor korte tijd worden geopend, bijv. voor een visuele diagnose. Bedien hierbij geen schakelaar, trek of steek geen modules en ontkoppel geen elektrische leidingen (steekverbindingen).

Deze waarschuwing kan buiten beschouwing blijven, indien bekend is dat er geen explosieve atmosfeer heerst.

Lijst van de toegelaten modules

De lijst met de toegelaten modules vindt u in het internet:

<http://www4.ad.siemens.de/view/cs/>

onder de bijdrage-ID 13702947

1.6.7 Brug af S7-400 i det eksplosionsfarlige område zone 2

Zone 2

Eksplodingsfarlige områder inddeles i zoner. Zonerne adskiller sig indbyrdes efter hvor sandsynligt det er, at der er en eksplosiv atmosfære.

| Zone | Eksplodingsfare | Eksempel |
|----------------|--|--|
| 2 | Eksplodings gasatmosfære optræder kun sjældent og varer kort | Områder rundt om flangeforbindelser med flade pakninger ved rørledninger i lukkede rum |
| Sikkert område | Nej | <ul style="list-style-type: none">• Uden for zone 2• Standardanvendelser decentral periferi |

I det følgende findes vigtige henvisninger vedr. installation af SIMATIC S7-400 i det eksplosionsfarlige område.

Yderligere informationer

Yderligere informationer om de forskellige S7-400-komponenter findes i manualen.

Produktionssted

Siemens AG, Bereich A&D
Östliche Rheinbrückenstraße 50
76187 Karlsruhe
Germany

Godkendelse

 II 3 G EEx nA II T3 .. T6 efter EN 50021 : 1999
Kontrolnummer: **KEMA 03ATEX1125 X**

Bemærk

Komponenter med godkendelsen  II 3 G EEx nA II T3 .. T6 må kun monteres i automatiseringssystemer SIMATIC S7-400 - udstyrskategori 3.

Vedligeholdelse

Skal den pågældende komponent repareres, bedes De sende den til produktionsstedet. Reparation må kun udføres der.

Særlige betingelser

1. SIMATIC S7-400 skal monteres i et kontrolskab eller et metalkabinet. Disse skal mindst kunne sikre beskyttelsesklasse IP 54. I denne forbindelse skal der tages højde for de omgivelsestemperaturer, i hvilke udstyret er installeret. Der skal være udarbejdet en erklæring fra fabrikanten for kabinettet for zone 2 (iht. EN 50021).
2. Hvis kablet eller kabelindføringen på dette hus når op på en temperatur på $> 70\text{ }^{\circ}\text{C}$ under driftsbetingelser eller hvis temperaturen på åreforegningen kan være $> 80\text{ }^{\circ}\text{C}$ under driftsbetingelser, skal kablernes temperaturegenskaber stemme overens med de temperaturer, der rent faktisk måles.
3. De benyttede kabelindføringer skal være i overensstemmelse med den krævede IP-beskyttelsestype og afsnittet 7.2 (iht. EN 50021).
4. Alle apparater, inkl. kontakter osv., der forbindes med ind- og udgangene på S7-400 systemer, skal være godkendt til eksplosionsbeskyttelse af type EEx nA eller EEx nC.
5. Der skal træffes foranstaltninger, der sørger for, at den nominelle spænding via transienter ikke kan overskrides mere end 40 %.
6. Omgivelsestemperaturområde: 0°C til 60°C
7. I kabinettet skal der anbringes et skilt, der skal kunne ses, når kabinettet åbnes. Dette skilt skal have følgende advarsel:

Advarsel

Kabinettet må kun åbnes i kort tid, f.eks. til visuel diagnose. Tryk i denne forbindelse ikke på kontakter, træk eller isæt ikke komponenter og afbryd ikke elektriske ledninger (stikforbindelser).

Denne advarsel skal der ikke tages højde for, hvis man ved, at der ikke er nogen eksplosionsfarlig atmosfære.

Liste over godkendte komponenter

Listen med de godkendte komponenter findes på internettet:

<http://www4.ad.siemens.de/view/cs/>

under bidrags-ID 13702947

1.6.8 S7-400:n käyttö räjähdysvaarannetuilla alueilla, vyöhyke 2

Vyöhyke 2

Räjähdysvaarannetut alueet jaetaan vyöhykkeisiin. Vyöhykkeet erotellaan räjähdyskelpoisen ilmakehän olemassa olon todennäköisyyden mukaan.

| Vyöhyke | Räjähdysvaara | Esimerkki |
|------------------|--|--|
| 2 | Räjähävä kaasuilmakehä ilmaantuu vain harvoin ja lyhytaikaisesti | Alueet putkistojen lattatiivisteillä varustuilla laippaliitoksilla suljetuissa tiloissa |
| turvallinen alue | Ei | <ul style="list-style-type: none">vyöhykkeen 2 ulkopuolellaHajautetun ulkopiirin vakiosovellukset |

Seuraavasta löydätte tärkeitä ohjeita
SIMATIC S7-400 asennukseen räjähdysvaarannetuilla alueilla.

Lisätietoja

Lisätietoja erilaisiin S7-400-rakenneryhmiin löydätte ohjekirjasta.

Valmistuspaikka

Siemens AG, Bereich A&D
Östliche Rheinbrückenstraße 50
76187 Karlsruhe
Germany

Hyväksyntä

 II 3 G EEx nA II T3 .. T6 EN 50021 mukaan: 1999

Tarkastusnumero: **KEMA 03ATEX1125 X**

Ohje

Rakenneryhmät hyväksynnän  II 3 G EEx nA II T3 .. T6 kanssa saadaan käyttää ainoastaan laitekategorian 3 automatisointijärjestelmissä SIMATIC S7-400.

Kunnossapito

Korjausta varten täytyy kyseinen rakenneryhmä lähettää valmistuspaikkaan. Korjaus voidaan suorittaa ainoastaan siellä.

Erityiset vaatimukset

1. SIMATIC S7-400 täytyy asentaa kytkentäkaappiin tai metalliseen koteloon. Näiden täytyy olla vähintään kotelointiluokan IP 54 mukaisia. Tällöin on huomioitava ympäristöolosuhteet, johon laite asennetaan. Kotelolle täytyy olla valmistajaselvitys vyöhykettä 2 varten (EN 50021 mukaan).
2. Kun johdolla tai tämän kotelon johdon sisäänviennillä saavutetaan $> 70^{\circ}\text{C}$ lämpötila tai kun käyttöolosuhteissa lämpötila voi pihuhajaotuksella olla $> 80^{\circ}\text{C}$, täytyy johdon lämpötilaominaisuuksien vastata todellisesti mitattuja lämpötiloja.
3. Käytettyjen johtojen sisäänohjauksien täytyy olla vaaditun IP-kotelointiluokan ja kohdan 7.2 (EN 50021 mukaan) mukaisia.
4. Kaikkien laitteiden, kytkimet jne. mukaan lukien, jotka liitetään virheitä suojattujen signaalirakenneryhmien tuloille ja lähdöille, täytyy olla hyväksytyjä tyyppin EEx nA tai EEx nC räjähdysuojausta varten.
5. Toimenpiteet täytyy suorittaa, ettei nimellisjännite voi transienttien kautta ylittyä enemmän kuin 40 %.
6. Ympäristölämpötila-alue: $0^{\circ}\text{C} \dots 60^{\circ}\text{C}$
7. Kotelon sisälle, avauksen jälkeen näkyvälle paikalle, on kiinnitettävä kilpi, jossa on seuraava varoitus:

Varoitus

Kotelo saadaan avata ainoastaan lyhyeksi ajaksi, esim. visuaalista diagnoosia varten. Älä tällöin käytä mitään kytkimiä, vedä tai liitä mitään rakenneryhmiä, äläkä erota mitään sähköjohtoja (pistoliittimiä). Tätä varoitusta ei tarvitse huomioida, kun on tiedossa, että minkäänlaista räjähdysvaarannettua ilmakehää ei ole olemassa.

Hyväksytyjen rakenneryhmien lista

Lista hyväksytyistä rakennesarjoista löytyy internetistä osoitteesta:

<http://www4.ad.siemens.de/view/cs/>

käyttäjätunnuksella 13702947

1.6.9 Användning av S7-400 i explosionsriskområde zon 2

Zon 2

Explosionsriskområden delas in i zoner. Zonerna delas in enligt sannolikheten att en atmosfär med explosionsfara föreligger.

| Zon | Explosionsfara | Exempel |
|---------------|---|--|
| 2 | Explosiv gasatmosfär uppstår endast sällan eller kortvarigt | Områden kring flänsförbindelser med packningar vid rörledningar i slutna utrymmen |
| Säkert område | Nej | <ul style="list-style-type: none">• Utanför zon 2• Standardanvändning av decentral periferi |

Nedan följer viktiga anvisningar om installationen av SIMATIC S7-400 i ett explosionsriskområde.

Ytterligare information

Ytterligare information om de olika S7-400-komponentgrupperna finner du i handboken.

Tillverkningsort

Siemens AG, Bereich A&D
Östliche Rheinbrückenstraße 50
76187 Karlsruhe
Germany

Godkännande

 II 3 G EEx nA II T3 .. T6 enligt EN 50021 : 1999
Kontrollnummer: **KEMA 03ATEX1125 X**

Anvisning

Komponentgrupper med godkännande  II 3 G EEx nA II T3 .. T6 får endast användas i automatiseringssystemen SIMATIC S7-400 från apparatgrupp 3.

Underhåll

Vid reparation måste den aktuella komponentgruppen insändas till tillverkaren. Reparationer får endast genomföras där.

Särskilda villkor

1. SIMATIC S7-400 måste monteras i ett kopplingskåp eller metallhus. Dessa måste minst vara av skyddsklass IP 54. Därvid ska omgivningsvillkoren där enheten installeras beaktas. För kåpan måste en tillverkardeklaration för zon 2 föreligga (enligt EN 50021).
2. Om en temperatur på $> 70^{\circ}\text{C}$ uppnås vid husets kabel resp kabelinföring under driftvillkor eller om temperaturen vid trådförgreningen kan vara $> 80^{\circ}\text{C}$ under driftvillkor, måste kabelns temperaturegenskaper överensstämja med den verkliga uppmätta temperaturen.
3. De använda kabelinföringarna måste uppfylla kraven i det krävda IP-skyddsutförandet och i avsnitt 7.2 (enligt EN 50021).
4. Alla apparater, inklusive brytare osv, som ansluts S7 400 systemens in- och utgångar, måste vara godkända för explosionskydd av typ EEx nA eller EEx nC.
5. Åtgärder måste vidtas så, att märkspänningen ej kan överskridas med mer än 40 % genom transienter.
6. Omgivningstemperatur: 0°C till 60°C
7. När huset öppnats ska en skylt med följande varning monteras på ett tydligt synligt ställe huset:

Varning

Huset får endast öppnas under kort tid, t ex för visuell diagnos. Använd därvid inga brytare, lossa eller anslut inga enheter och frånskilj inga elektriska ledningar (insticksanslutningar).

Ingen hänsyn måste tas till denna varning om det är säkert att det inte råder någon explosionsfarlig atmosfär.

Lista över godkända komponentgrupper

Lista över godkända enheter återfinns i Internet:

<http://www4.ad.siemens.de/view/cs/>

under bidrags-ID 13702947

1.6.10 Uso do S7-400 em área exposta ao perigo de explosão 2

Zona 2

As áreas expostas ao perigo de explosão são divididas em zonas. As zonas são diferenciadas de acordo com a probabilidade da existência de uma atmosfera explosiva.

| Zona | Perigo de explosão | Exemplo |
|-------------|---|---|
| 2 | Só raramente e por um breve período de tempo surgem atmosferas explosivas | Áreas em torno de ligações flangeadas com vedações chatas em tubulações em recintos fechados |
| Área segura | Não | <ul style="list-style-type: none">• fora da zona 2• Aplicações padrão de periferia descentralizada |

A seguir, o encontrará avisos importantes para a instalação do SIMATIC S7-400 em área exposta ao perigo de explosão.

Mais informações

Para obter mais informações sobre os diversos componentes S7-400, consulte o manual.

Local de produção

Siemens AG, Bereich A&D
Östliche Rheinbrückenstraße 50
76187 Karlsruhe
Germany

Licença

 II 3 G EEx nA II T3 .. T6 seg. EN 50021 : 1999

Número de ensaio: **KEMA 03ATEX1125 X**

Aviso

Componentes com a licença  II 3 G EEx nA II T3 .. T6 só podem ser aplicados em sistemas de automação SIMATIC S7-400 da categoria de aparelho 3.

Reparo

Os componente em questão deve ser remetido para o local de produção a fim de que seja realizado o reparo. Apenas lá deve ser efetuado o reparo.

Condições especiais

1. O SIMATIC S7-400 deve ser montado em um armário de distribuição ou em uma caixa metálica. Estes devem garantir no mínimo o tipo de proteção IP 54. Durante este trabalho deverão ser levadas em consideração as condições locais, nas quais o aparelho será instalado. Para a caixa deverá ser apresentada uma declaração do fabricante para a zona 2 (de acordo com EN 50021).
2. Caso no cabo ou na entrada do cabo desta caixa sob as condições operacionais seja atingida uma temperatura de $> 70^{\circ}\text{C}$ ou caso sob condições operacionais a temperatura na ramificação do fio possa atingir $> 80^{\circ}\text{C}$, as características de temperatura deverão corresponder às temperaturas realmente medidas.
3. As entradas de cabo utilizadas devem corresponder ao tipo exigido de proteção IP e à seção 7.2 (de acordo com o EN 50021).
4. Todos os aparelhos, inclusive as chaves, etc., que estejam conectadas em entradas e saídas dos sistemas do S7;400 devem possuir a licença para a proteção de explosão do tipo EEx nA ou EEx nC.
5. Precisam ser tomadas medidas para que a tensão nominal através de transitórios não possa ser ultrapassada em mais que 40 %.
6. Área de temperatura ambiente: 0°C até 60°C
7. No âmbito da caixa deve ser colocada em um ponto bem visível após a sua abertura uma placa com a seguinte advertência:

Advertência

A carcaça deve ser aberta apenas por um breve período de tempo, por ex. para diagnóstico visual. Não acione nenhum interruptor, não retire ou conecte nenhum componente e não separe nenhum fio elétrico (ligações de tomada). Esta advertência poderá ser ignorada caso se saiba que não há atmosfera alguma sujeita ao perigo de explosão.

Lista dos componentes autorizados

A lista com os componentes autorizados encontram-se na Internet:

<http://www4.ad.siemens.de/view/cs/>

sob o número de ID 13702947

1.6.11 Χρήση της συσκευής S7-400 σε επικίνδυνη για έκρηξη περιοχή, ζώνη 2

Ζώνη 2

Οι επικίνδυνες για έκρηξη περιοχές χωρίζονται σε ζώνες. Οι ζώνες διαφέρουν σύμφωνα με την πιθανότητα ύπαρξης ενός ικανού για έκρηξη περιβάλλοντος.

| Ζώνη | Κίνδυνος έκρηξης | Παράδειγμα |
|-----------------|--|---|
| 2 | Εκρηκτικό περιβάλλον αερίου παρουσιάζεται μόνο σπάνια και για σύντομο χρονικό διάστημα | Περιοχές γύρω από φλαντζωτές συνδέσεις με τσιμούχες σε σωληνώσεις σε κλειστούς χώρους |
| Ασφαλής περιοχή | Όχι | <ul style="list-style-type: none"> Εκτός της ζώνης 2 Τυπικές εφαρμογές αποκεντρωμένης περιφέρειας |

Στη συνέχεια θα βρείτε σημαντικές υποδείξεις για την εγκατάσταση του δομικού συγκροτήματος SIMATIC S7-400 σε επικίνδυνη για έκρηξη περιοχή.

Επιπλέον πληροφορίες

Επιπλέον πληροφορίες για τα διάφορα δομικά συγκροτήματα (ενότητες) S7-400 θα βρείτε στο εγχειρίδιο.

Τόπος κατασκευής

Siemens AG, Bereich A&D
Östliche Rheinbrückenstrasse 50
76187 Karlsruhe
Germany

Άδεια

 II 3 G EEx nA II T3 .. T6 σύμφωνα με το πρότυπο
EN 50021 : 1999

Αριθμός ελέγχου: **KEMA 03ATEX1125 X**

Υπόδειξη

Τα δομικά συγκροτήματα με την άδεια  II 3 G EEx nA II T3 .. T6 επιτρέπεται να τοποθετηθούν μόνο σε συστήματα αυτοματισμού SIMATIC S7-400 της κατηγορίας συσκευής 3.

Συντήρηση

Για μια επισκευή πρέπει να σταλθεί το αντίστοιχο δομικό συγκρότημα στον τόπο κατασκευής. Μόνο εκεί επιτρέπεται να γίνει η επισκευή.

Ιδιαίτερες προϋποθέσεις

1. Το δομικό συγκρότημα SIMATIC S7-400 πρέπει να ενσωματωθεί σε ένα ερμάριο ζεύξης ή σε ένα μεταλλικό περίβλημα. Αυτά πρέπει να εξασφαλίζουν το λιγότερο το βαθμό προστασίας IP 54. Σε αυτήν την περίπτωση πρέπει να ληφθούν υπόψη οι περιβαλλοντικές συνθήκες, στις οποίες θα εγκατασταθεί η συσκευή. Για το περίβλημα πρέπει να προβλέπεται δήλωση του κατασκευαστή για τη ζώνη 2 (σύμφωνα με το πρότυπο EN 50021).
2. Εάν στο καλώδιο ή στην είσοδο του καλωδίου αυτού του περιβλήματος κάτω από συνθήκες λειτουργίας η θερμοκρασία ξεπεράσει τους 70 °C ή όταν κάτω από συνθήκες λειτουργίας η θερμοκρασία στη διακλάδωση του σύρματος μπορεί να είναι μεγαλύτερη από 80 °C, πρέπει οι θερμοκρασιακές ιδιότητες των καλωδίων να ταυτίζονται με τις πραγματικά μετρημένες θερμοκρασίες.
3. Οι χρησιμοποιούμενες εισόδους καλωδίων πρέπει να συμμορφώνονται με το βαθμό προστασίας IP 54 στην ενότητα 7.2 (σύμφωνα με το πρότυπο EN 50021).
4. Όλες οι συσκευές, συμπεριλαμβανομένων διακοπών κ.α., που συνδέονται στις εισόδους και εξόδους των συστημάτων S7-400, πρέπει να φέρουν εγκριμένη προστασία κατά έκρηξης τύπου EEx nA ή EEx nC.
5. Πρέπει να ληφθούν μέτρα, να μην μπορεί να γίνει υπέρβαση της ονομαστικής τάσης μέσω αιφνίδιας μεταβολής της τάσης πάνω από 40 %.
6. Περιοχή θερμοκρασίας περιβάλλοντος: 0° C έως 60° C
7. Πρέπει να τοποθετηθεί μέσα στο περίβλημα σε ευδιάκριτο σημείο μετά το άνοιγμα μία πινακίδα με την ακόλουθη προειδοποίηση:

Προειδοποίηση

Το περίβλημα επιτρέπεται να ανοίγει μόνο για μικρό χρονικό διάστημα, π.χ. για τη διενέργεια οπτικής διάγνωσης. Μην κάνετε χρήση διακοπών, μην τραβάτε ή εμβυσματώνετε δομικά συγκροτήματα και μη διαχωρίζετε ηλεκτροφόρους αγωγούς (εμβυσματώσιμες συνδέσεις).

Η προειδοποίηση αυτή δε χρειάζεται να ληφθεί υπ' όψιν, εάν είναι γνωστό ότι δεν υφίσταται ατμόσφαιρα παρουσιάζουσα κίνδυνο έκρηξης.

Κατάλογος των εγκεκριμένων δομικών συγκροτημάτων

Η λίστα με τα εγκεκριμένα δομικά συγκροτήματα υπάρχει στο διαδίκτυο:

<http://www4.ad.siemens.de/view/cs/>

με τον κωδικό συνδρομής 13702947

Racks

2

Chapter Overview

| Section | Description | Page |
|---------|---|------|
| 2.1 | Function and Structure of the Racks | 2-2 |
| 2.2 | The Racks UR1; (6ES7400-1TA01-0AA0) and UR2; (6ES7400-1JA01-0AA0) | 2-3 |
| 2.3 | The Rack UR2-H; (6ES7400-2JA00-0AA0) | 2-5 |
| 2.4 | The Rack CR2; (6ES7401-2TA01-0AA0) | 2-7 |
| 2.5 | The Rack CR3; (6ES7401-2TA01-0AA0) | 2-8 |
| 2.6 | The Racks ER1; (6ES7403-1TA01-0AA0) and ER2; (6ES7403-1JA01-0AA0) | 2-9 |

2.1 Function and Structure of the Racks

Introduction

The racks in the S7-400 have the following tasks:

- They hold the modules
- They supply the modules with operating voltage
- They connect the individual modules to each other via the signal buses

Structure of the Racks

A rack consists of the following elements:

- Mounting rail with threaded bolts for fixing the modules and lateral cutouts for mounting the rack
- Plastic parts that function, among other things, as guides when swinging the modules into place.
- A backplane bus, an I/O bus and, if necessary, a communication bus with bus connector
- Connection for local ground

Figure 2-1 shows the mechanical configuration of a rack (UR1).

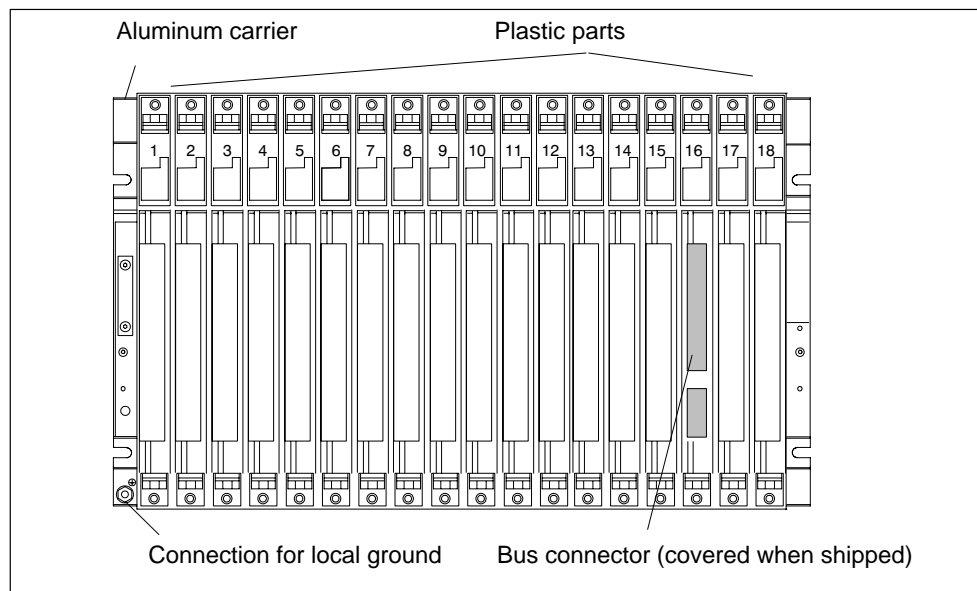

Figure 2-1 Structure of a Rack with 18 Slots

UL/CSA Note

Special requirements should be taken into consideration in the area of influence of the UL/CSA; these may be fulfilled by installing the system in a cabinet.

2.2 The Racks UR1; (6ES7400-1TA01-0AA0) and UR2; (6ES7400-1JA01-0AA0)

Introduction

The UR1 and UR2 racks are used for assembling central racks and expansion racks. The UR1 and UR2 racks have both an I/O bus and a communication bus.

Suitable Modules for UR1 and UR2

You can use the following modules in the UR1 and UR2 racks:

- When the UR1 or UR2 is used as a central rack:
All S7-400 modules with the exception of receive IMs
- When the UR1 or UR2 is used as an expansion rack:
All S7-400 modules with the exception of CPUs and send IMs

Special case: Power supply modules cannot be used in conjunction with the IM 461-1 receive IM.

Structure of the UR1 and UR2

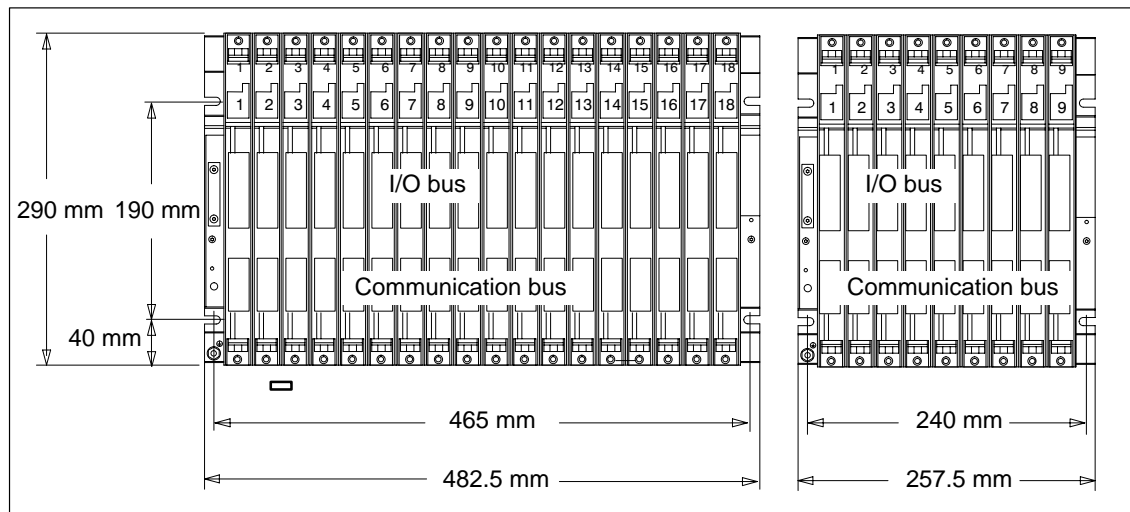

Figure 2-2 Dimensions of the UR1 18-Slot or UR2 9-Slot Rack

Technical Specifications of the UR1 and UR2 Racks

| Rack | UR1 | UR2 |
|------------------------------|-------------------------------|------------------------------|
| Number of single-width slots | 18 | 9 |
| Dimensions W x H x D (in mm) | 482.5 x 290 x 27.5 | 257.5 x 290 x 27.5 |
| Weight (in kg) | 3 4.1 as of version 03 | 1.5 2.15 as of version 04 |
| Buses | I/O bus and communication bus | |

2.3 The Rack UR2-H; (6ES7400-2JA00-0AA0)

Introduction

The UR2-H rack is used for assembling two central racks or expansion racks in one rack. The UR2-H rack essentially represents two electrically isolated UR2 racks on the same rack profile. The main area of application of the UR2-H is in the compact structure of redundant S7-400H systems (two subracks or subsystems in one rack).

Suitable Modules for the UR2-H

You can use the following modules in the UR2-H rack:

When the UR2-H is used as a central rack:

- All S7-400 modules with the exception of receive IMs

When the UR2-H is used as an expansion rack:

- All S7-400 modules apart from CPUs, send IMs, the IM 463-2, and the adapter module

Special case: Power supply modules cannot be used in conjunction with the IM 461-1 receive IM.

Structure of the UR2-H

Figure 2-3 shows the structure of the UR2-H rack with 2 x 9 slots.

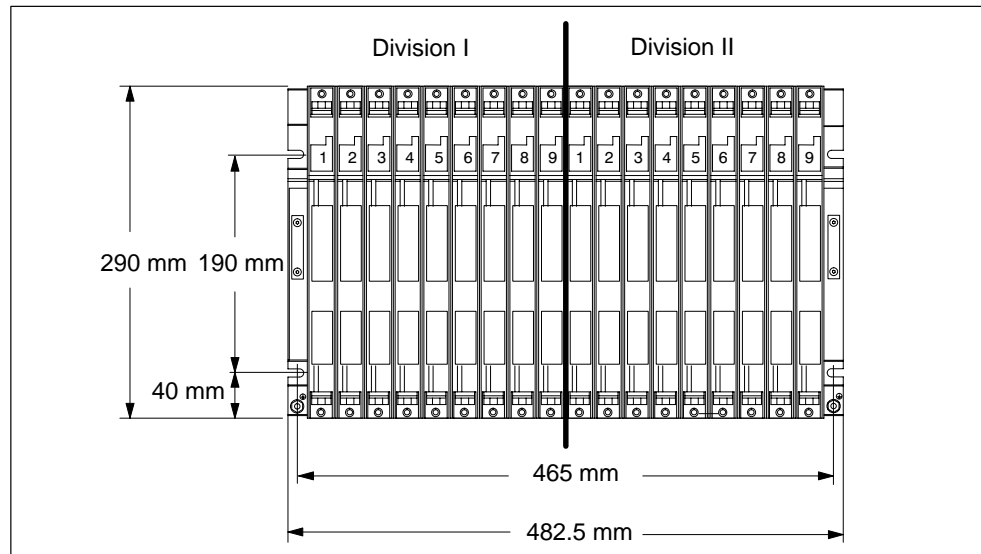

Figure 2-3 Rack Dimensions

**Caution**

Danger of damage to equipment.

If you insert a power supply module in a slot that is not permitted for power supply modules, the module may be damaged. Slots 1 to 4 are permitted, whereby power supply modules starting from slot 1 must be inserted without leaving gaps.

Make sure that power supply modules are only inserted in permitted slots. Take particular notice of the option of swapping modules in slot 1 on subrack II and slot 9 on subrack I.

Technical Specifications of the UR2-H Rack

| Rack | UR2-H |
|------------------------------|---|
| Number of single-width slots | 2 x 9 |
| Dimensions W x H x D (in mm) | 482.5 x 290 x 27.5 |
| Weight (in kg) | 3 4.1 as of version 03 |
| Buses | Segmented I/O bus, segmented communication bus |

2.4 The Rack CR2; (6ES7401-2TA01-0AA0)

Introduction

The CR2 rack is used for assembling segmented central racks. The CR2 has both an I/O bus and a communication bus. The I/O bus is split into two local bus segments with 10 or 8 slots.

Suitable Modules for the CR2

You can use the following modules in the CR2 rack:

- All S7-400 modules with the exception of receive IMs

Structure of the CR2

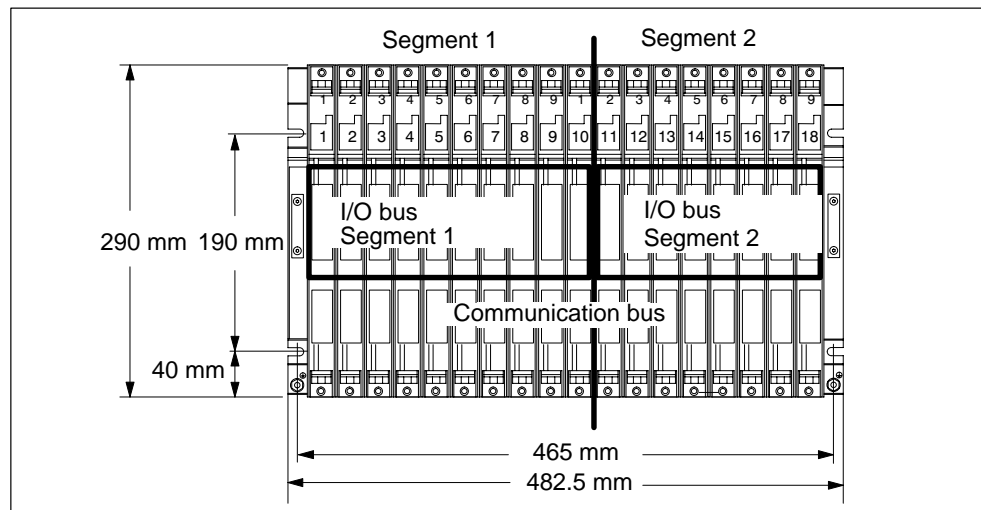

Figure 2-4 CR2 Rack

Technical Specifications of the CR2 Rack

| Rack | CR2 |
|---------------------------------------|--|
| Number of single-width slots | 18 |
| Dimensions W x H x D (in mm) | 482.5 x 290 x 27.5 |
| Weight | 3 kg 4.1 as of version 03 |
| Busses | Segmented I/O bus, continuous communication bus |
| Only one power supply module required | |

2.5 The Rack CR3; (6ES7401-2TA01-0AA0)

Introduction

The CR3 rack is used for the assembly of CRs in standard systems (not in fault-tolerant systems). The CR3 has an I/O bus and a communication bus.

Suitable Modules for CR 3

You can use the following modules in CR3:

- All S7-400 modules with the exception of receive IMs
- You can only use the CPU 414-4H and CPU 417-4H in stand-alone operation.

Structure of the CR3

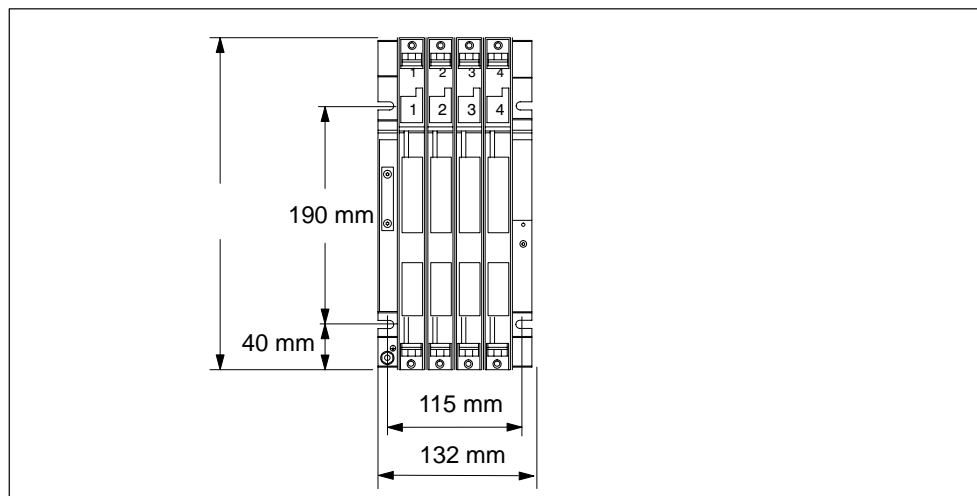

Figure 2-5 CR3 Rack

Technical Specifications of the CR3 Rack

| Rack | CR3 |
|--------------------------------|----------------------------------|
| Associated programming package | As of STEP7 V 5.1; ServicePack 3 |
| Number of single-width slots | 4 |
| Dimensions W x H x D (in mm) | 122.5 x 290 x 27.5 |
| Weight (in kg) | 0.75 |
| Buses | I/O bus and communication bus |

2.6 The Racks ER1; (6ES7403-1TA01-0AA0) and ER2; (6ES7403-1JA01-0AA0)

Introduction

The ER1 and ER2 racks are used for assembling expansion racks.

The ER1 and ER2 racks have only one I/O bus with the following restrictions:

- Interrupts from modules in the ER1 or ER2 have no effect since there are no interrupt lines provided.
- Modules in the ER1 or ER2 are not supplied with 24 V. Modules requiring a 24 V supply are not provided for use in the ER1 or ER2.
- Modules in the ER1 or ER2 are not backed up either by the battery in the power supply module or by the voltage supplied externally to the CPU or the receive IM (EXT.-BATT. socket).

There is therefore no advantage in using backup batteries in the power supply modules in ER1 and ER2.

Battery faults and backup voltage faults are not reported to the CPU.

The battery monitoring function of a power supply module installed in the ER1 or ER2 should therefore always be switched off.

Suitable Modules for ER1 and ER2

You can use the following modules in the ER1 and ER2 racks:

- All power supply modules
- Receive IMs
- All signal modules provided the above-mentioned restrictions are observed.

However: Power supply modules cannot be used in conjunction with the IM 461-1 receive IM.

Structure of ER1 and ER2

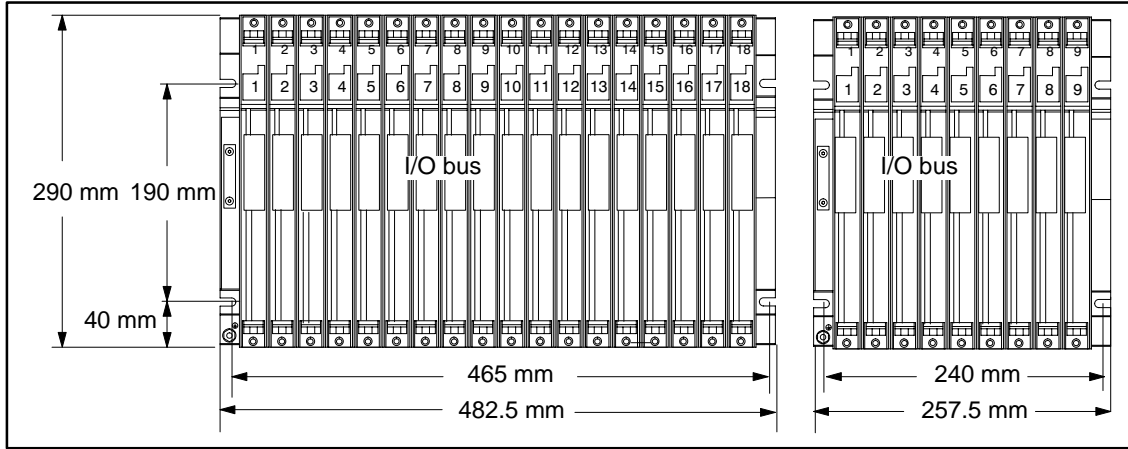

Figure 2-6 ER1 Rack with 18 Slots and ER2 Rack with 9 Slots

Technical Specifications of the ER1 and ER2 Racks

| Rack | ER1 | ER2 |
|------------------------------|-----------------------------|------------------------------|
| Number of single-width slots | 18 | 9 |
| Dimensions W x H x D (in mm) | 482.5 x 290 x 27.5 | 257.5 x 290 x 27.5 |
| Weight (in kg) | 2.5 3.8 as of version 03 | 1.25 2.0 as of version 03 |
| Busses | Restricted I/O bus | Restricted I/O bus |

3

Power Supply Modules

Chapter Overview

| Section | Description | Page |
|---------|--|------|
| 3.1 | Common Characteristics of the Power Supply Modules | 3-2 |
| 3.2 | Redundant Power Supply Modules | 3-4 |
| 3.3 | Backup Battery (Option) | 3-6 |
| 3.4 | Controls and Indicators | 3-8 |
| 3.5 | Fault/Error Messages via LEDs | 3-13 |
| 3.6 | Power Supply Module PS 407 4A; (6ES7407-0DA00-0AA0) | 3-19 |
| 3.7 | Power Supply Module PS 407 4A; (6ES7407-0DA01-0AA0) | 3-21 |
| 3.8 | Power Supply Modules PS 407 10A; (6ES7407-0KA01-0AA0) and PS 407 10A R; (6ES7407-0KR00-0AA0) | 3-23 |
| 3.9 | Power Supply Module PS 407 20A; (6ES7407-0RA00-0AA0) | 3-26 |
| 3.10 | Power Supply Module PS 407 20A; (6ES7407-0RA01-0AA0) | 3-28 |
| 3.11 | Power Supply Module PS 405 4A; (6ES7405-0DA00-0AA0) | 3-30 |
| 3.12 | Power Supply Module PS 405 4A; (6ES7405-0DA01-0AA0) | 3-32 |
| 3.13 | Power Supply Module PS 405 10A; (6ES7405-0KA00-0AA0) | 3-34 |
| 3.14 | Power Supply Modules PS 405 10A; (6ES7405-0KA01-0AA0) and PS 405 10A R; (6ES7405-0KR00-0AA0) | 3-36 |
| 3.15 | Power Supply Module PS 405 20A; (6ES7405-0RA00-0AA0) | 3-38 |
| 3.16 | Power Supply Module PS 405 20A; (6ES7405-0RA01-0AA0) | 3-40 |

3.1 Common Characteristics of the Power Supply Modules

Tasks of the Power Supply Modules

The power supply modules of the S7-400 supply the other modules in the rack with their operating voltages via the backplane bus. They do not provide load voltages for the signal modules.

Common Characteristics of the Power Supply Modules

The power supply modules share certain common characteristics in addition to their special technical specifications. The most important common characteristics are:

- Encapsulated design for use in mounting racks of the S7-400 system
- Cooling via natural convection
- Plug-in connection of the supply voltage with AC - DC coding
- Protection class I (with protective conductor) in accordance with IEC 60536; VDE 0106, Part 1
- Limitation of making current in accordance with NAMUR recommendation part 1 of August 1998
- Short circuit-proof outputs
- Monitoring of both output voltages. If one of these voltages fails, the power supply module signals a fault to the CPU.
- Both output voltages (5 VDC and 24 VDC) share a common ground.
- Primary clocked
- Battery backup as option. The parameters set and the memory contents (RAM) are backed up via the backplane bus in the CPUs and programmable modules. In addition, the backup battery enables you to carry out a restart of the CPU. Both the power supply module and the backed up modules monitor the battery voltage.
- Operating and fault/error LEDs on the front plate.

Warning

A mains disconnecting device must be provided when installing AC power supply modules.

Switching the Line Voltage Off/On

The power supply modules have a making-current limiter in accordance with NAMUR.

Power Supply Module in Invalid Slot

If you insert the power supply module of a rack in an invalid slot, it will not power up. In this case, proceed as follows to start up the power supply module correctly:

1. Disconnect the power supply module from the mains (not just the standby switch).
2. Remove the power supply module.
3. Install the power supply module in slot 1.
4. Wait at least 1 minute and then switch the line voltage on again.



Caution

Damage can result.

If you insert the power supply module in a slot that is not intended for power supply modules, the module may be damaged. Slots 1 to 4 are permissible as long as you start at slot 1 and leave no gaps.

Make sure that power supply modules are only inserted in permissible slots.

Compliance with the NAMUR Recommendation

If you use one of the modules listed below, you can achieve mains buffering in accordance with the NAMUR recommendation with a central power supply in accordance with NAMUR or an uninterrupted power supply.

Table 3-1 Compliance with the NAMUR recommendation

| Name | Order number |
|---------------------------------|--------------------|
| Power Supply Module PS 407 4 A | 6ES7407-0DA00-0AA0 |
| Power Supply Module PS 407 20 A | 6ES7407-0RA00-0AA0 |
| Power Supply Module PS 405 4 A | 6ES7405-0DA00-0AA0 |
| Power Supply Module PS 405 10 A | 6ES7405-0KA00-0AA0 |
| Power Supply Module PS 405 20 A | 6ES7405-0RA00-0AA0 |

3.2 Redundant Power Supply Modules

Order Numbers and Function

Table 3-2 Redundant power supply modules

| Type | Order Number | Input Voltage | Output Voltage | See Section |
|--------------|--------------------|---|------------------------------|-------------|
| PS 407 10A R | 6ES7407-0KR00-0AA0 | 85 VAC to 264 VAC or 88 VDC to 300 VDC | 5 VDC/10 A and 24 VDC/1 A | 3.8 |
| PS 405 10A R | 6ES7405-0KR00-0AA0 | 19.2 VDC to 72 VDC | 5 VDC/10 A and 24 VDC/1 A | 3.14 |

Redundant Operation

If you use two power supply modules of type PS 407 10A R or PS 405 10A R, you can install a redundant power supply on a mounting rack. We recommend this if you want to increase the availability of your programmable controller, particularly if you are operating it on an unreliable power system.

Configuring a Redundant Power Supply

Redundant operation is possible with any of the S7 CPUs and racks described in this manual. STEP 7 as of V4.02 is also required.

To set up a redundant power supply, insert a power supply module in slots 1 and 3 of the rack. You can then insert as many modules as can be supplied by a single power supply module. In other words, in redundant operation all the modules can only draw a total of 10 A.

Characteristics

The redundant power supply of an S7-400 has the following characteristics:

- The power supply module delivers a making current in accordance with NAMUR.
- Each of the power supply modules can take over the supply of power to the whole rack if the other one fails. There is no loss of operation.
- Each of the power supply modules can be exchanged while the system is in operation. No loss of power and no peak stress occurs with the effective voltages when the modules are removed or inserted.
- Each of the power supply modules monitors its function and sends a message if it fails.
- Neither of the power supply modules can generate an error which affects the output voltage of the other power supply module.
- A redundant battery concept (backup concept) is only provided when two backup batteries are used in each of the power supply modules. If only one battery is used in each module, only non-redundant backup is possible, since both batteries are being used at the same time.
- The failure of a power supply module is registered via a plug and remove interrupt (default STOP). Only if used in the second segment of the CR 2 is no message sent if the power supply module fails.
- If two power supply modules are inserted but only one is switched on, there is a power-up delay of up to one minute when the line voltage is switched on.

Note

The check box "Startup if preset configuration not equal to actual configuration" should be activated in the "Properties" dialog box of the CPU.

3.3 Backup Battery (Option)

Introduction

The power supply modules of the S7-400 have a battery compartment for one or two backup batteries. Use of these batteries is optional.

Function of the Backup Batteries

If backup batteries have been installed, the parameters set and the memory contents (RAM) will be backed up via the backplane bus in CPUs and programmable modules if the supply voltage fails. The battery voltage must be within the tolerance range.

In addition, the backup battery enables you to carry out a restart of the CPU after power-on.

Both the power supply module and the backed up modules monitor the battery voltage.

Power Supply Modules With Two Backup Batteries:

Some power supply modules contain a battery compartment for two batteries. If you use two batteries and set the switch to 2BATT, the power supply module defines one of the two batteries as the backup battery. This assignment remains in force until the battery is empty. When the backup battery is completely discharged, the system switches to the reserve battery which is then in turn used as the backup battery for the duration of its life. The status "backup battery" is also stored in the event of a power failure.

Battery Type

Only batteries approved by Siemens must be used (see Appendix C: Spare Parts)

The batteries can form a passivation layer. Depassivation takes place when the batteries are inserted in the power supply module.

Technical Specifications of the Backup Battery

| Backup Battery | |
|----------------|----------------|
| Order number | 6ES7971-0BA00 |
| Type | 1 x lithium AA |
| Rated voltage | 3.6 V |
| Rated capacity | 1.9 Ah |

Backup Times

The maximum backup time is based on the capacity of the backup batteries used and the backup current in the rack. The backup current is the sum of all individual currents of the inserted backed-up modules as well as the requirements of the power supply module when the power is switched off.

Example for the Calculation of Backup Times

The capacity of the batteries is listed in the technical specifications of the power supply. The typical and maximum backup current of the backed-up module is listed in the technical specifications of the module.

The typical backup current of a CPU is an empirically determined value. The maximum backup current is a worst-case value that is calculated based on the corresponding manufacturer specifications for the memory blocks.

The following technical specifications produce backup times for a CR with a PS 407 4A and a CPU 417-4 as the only backed-up module:

Capacity of the backup battery: 1.9 Ah

Maximum backup current (including own requirement at power off) of the power supply: 100 μ A

Typical backup current of the CPU 417-4: 75 μ A

A rated capacity of less than 100% is to be assumed when calculating the backup time because the backup battery is also affected at power on by the regular depassivation.

A battery capacity of 63% of the rated capacity produces the following values:

Backup time = $1.9 \text{ Ah} * 0.63 / (100 + 75) \mu\text{A} = (1.197 / 175) * 1\,000\,000 = 6840 \text{ h}$

This produces a maximum backup time of 285 days.

3.4 Controls and Indicators

Introduction

The power supply modules of the S7-400 have essentially the same controls and indicators. The main differences are:

- Not all the power supply modules have a voltage selector.
- Power supply modules with a backup battery have an LED (BATTF) that indicates an empty, defective, or missing backup battery.

Power supply modules with two redundant backup batteries have two LEDs (BATT1F and BATT2F) to indicate empty, defective or missing backup batteries.

Operator Controls and Indicators

Figure 3-1 shows you an example of a power supply module (PS 407 20A) with two (redundant) backup batteries. The LEDs are at the top left of the module front plate.

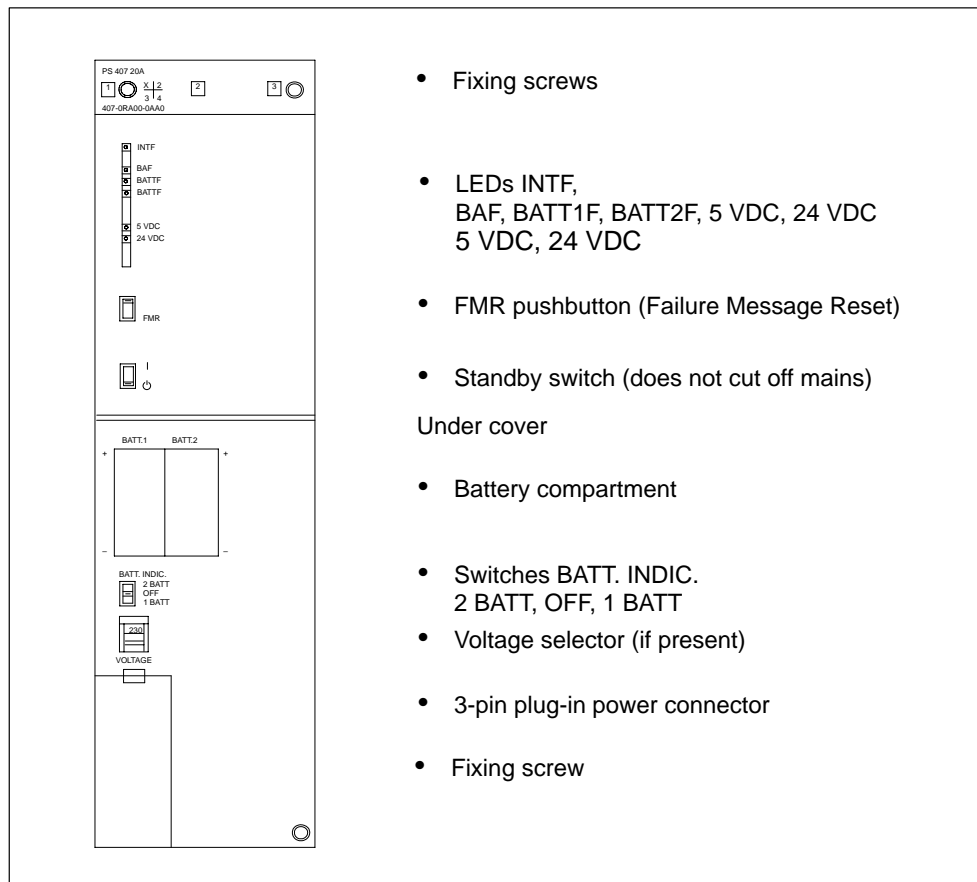

Figure 3-1 Controls and Indicators on the PS 407 20A Power Supply Module

Meaning of the LEDs

The meaning of the LEDs on the power supply modules is described in the tables below. Section 3.5 contains a list of the faults indicated by these LEDs and notes on how to acknowledge the faults.

INTF, 5 VDC, 24 VDC

Table 3-3 INTF, DC 5V, DC 24 V LEDs

| LED | Color | Meaning |
|--------|-------|--|
| INTF | red | Lights up in the event of an internal fault |
| 5 VDC | green | Lights up as long as the 5 V voltage is within the tolerance limits |
| 24 VDC | green | Lights up as long as the 24 V voltage is within the tolerance limits |

BAF, BATTF

Power supply modules with a backup battery have the following indicators:

Table 3-4 BAF, BATTF LEDs

| LED | Color | Meaning |
|-------|--------|---|
| BAF | Red | Lights up if the battery voltage on the backplane bus is too low and the BATT INDIC switch is at the BATT position |
| BATTF | Yellow | Lights up if the battery is empty, if the polarity is reversed, or if the battery is missing, and the BATT INDIC switch is at the BATT position |

BAF, BATT1F, BATT2F

Power supply modules with two backup batteries have the following indicators:

Table 3-5 BAF, BATT1F, BATT2F LEDs

| LED | Color | Meaning |
|-------|--------|--|
| BAF | Red | Lights up if the battery voltage on the backplane bus is too low and the BATT INDIC switch is at the 1 BATT or 2 BATT position |
| BATTF | Yellow | Lights up if battery 1 is empty or if the polarity is reversed or if the battery is missing, and the BATT INDIC switch is at the 1 BATT or 2 BATT position |
| BATTF | Yellow | Lights up if battery 2 is empty or if the polarity is reversed, or if the battery is missing, and the BATT INDIC switch is at the 2 BATT position |

Battery Voltage on the Backplane Bus

The battery voltage is either supplied by the backup battery or externally into the CPU or receive IM. In its normal state, the level of the battery voltage is between 2.7 V and 3.6 V.

The battery voltage is monitored for the lower limit. Violation of the lower limit is indicated by the BAF LED and reported to the CPU.

BAF lights up if the battery voltage on the backplane bus is too low. Possible causes of this include:

- Battery (batteries) empty or battery polarity has been reversed.
- External supply via CPU or receive IM is defective or supply from secondary power supply module is defective or missing.
- Short circuit or overload on the battery voltage.

Note

Due to internal capacities, if you remove the battery or switch off the external supply, some time may elapse before BAF, BATT1F, or BATT2F lights up.

Function of the Operator Controls

Table 3-6 Function of the operator controls of the power supply modules

| | |
|----------------------------------|---|
| FMR momentary-contact pushbutton | For acknowledging and resetting a fault indicator after correcting the fault |
| Standby switch | Switches the output voltages (5 VDC/24 VDC) to 0 V by intervening in the control loop (no mains disconnection). <ul style="list-style-type: none"> I : Output voltages at rated value ⏻ : Output voltages 0 V |
| BATT INDIC switch | Used for setting LEDs and battery monitoring <p>Where one battery can be used (PS 407 4A, PS 405 4A):</p> <ul style="list-style-type: none"> OFF: LEDs and monitor signals inactive BATT: BAF/BATTF LEDs and monitor signals active <p>Where two batteries can be used (PS 407 10A, PS 407 20A, PS 405 10A, PS 405 20A):</p> <ul style="list-style-type: none"> OFF: LEDs and monitor signals inactive 1 BATT: Only BAF/BATT1F LEDs (for battery 1) active. 2 BATT: BAF/BATT1F/BATT2F LEDs (for batteries 1 and 2) active. |
| Voltage selector (if present) | For setting the primary voltage (120 VAC or 230 VAC), protected by its own cover. (Please note the following information) |
| Battery compartment | For backup battery (batteries) |
| Power connection | 3-pin connector for line voltage connection (do not plug in or remove when power is on). |



Caution

One of the following power supply modules could be damaged:

Power supply module PS 407 4A (6ES7407-0DA00-0AA0)
 Power supply module PS 407 20A (6ES7407-0RA00-0AA0)

If you set the voltage selector to 120 V on these AC power supply modules and connect the power supply modules to a 230 V power system, it might damage the power supply modules. Warranty is excluded in such a case.

Set the voltage selector on these AC power supply modules to the line voltage.

Cover

The battery compartment, battery selector switch, voltage selector switch and power connection are housed under one cover. The cover must remain closed during operation in order to protect these operator controls and to prevent static electricity from affecting the battery connections.

If you have to carry out measurements on a module, you must discharge your body before you start the measurement by touching grounded metallic parts. Use grounded measuring devices only.

3.5 Fault/Error Messages via LEDs

Introduction

The power supply modules of the S7-400 indicate module faults and backup battery faults via LEDs on the front plate.

Overview of the Fault/Error Messages

Table 3-7 Error messages of the power supply modules

| Type of Fault/Error | LEDs |
|----------------------|--|
| Module fault | INTF 5 VDC 24 VDC |
| Backup battery fault | Power supplies with 1 backup battery: BAF BATTF |
| | Power supplies with 2 backup batteries: BAF BATT1F BATT2F |

INTF, 5 VDC, 24 VDC

The following table shows the faults indicated by the INTF, 5 VDC, and 24 VDC LEDs and lists how to remedy the faults.

The status of the BAF, BATTF, BATT1F, and BATT2F LEDs is not relevant here.

Table 3-8 INTF, DC5V, DC24V LEDs

| LED | | | Cause of Fault | Remedy |
|------|------|-------|--|---|
| INTF | DC5V | DC24V | | |
| D | D | D | Standby switch in  position | Set standby switch to the I position |
| | | | Line voltage missing | Check line voltage |
| | | | Internal fault, power supply module defective | Replace power supply module |
| | | | Cutoff after overvoltage on 5 V or illegal external supply | Disconnect from mains and reconnect after approximately 1 minute; if necessary, remove external supply |
| | | | Power supply module operated in wrong slot | Install the power supply module in the correct slot (slot 1) |
| | | | Short circuit or overload on 5 V | Switch off the power supply module, remove the source of the short circuit; after approximately 3 seconds, the power supply module can be switched on with the standby switch or via the power system.* |
| D | H | D | Overvoltage on 24 V | Check if the supply is external; if not, replace power supply module |

Table 3-8 INTF, DC5V, DC24V LEDs, continued

| LED | | | Cause of Fault | Remedy |
|------|------|--------|---|---|
| INTF | DC5V | DC24V | | |
| H | D* | D | Short circuit or overload on 5 V and 24 V | Check load on the power supply module. Possibly remove modules |
| H | D* | H/D ** | Short circuit or overload on 5 V | Check load on the power supply module. Possibly remove modules |
| H | H | D | If the standby switch is at the ϕ position, illegal external supply on 5 V | Remove all modules. Determine which module is faulty |
| | | | If the standby switch is at the I position, short-circuit or overload on 24 V | Check load on the power supply module. Possibly remove modules |
| D | B | H | Voltage restored after short circuit or overload on 5 V if faults occur in operation | Press FMR momentary-contact pushbutton: Flashing light changes to constant light |
| | | | Dynamic overload on 5 V | Check load on the power supply module. Possibly remove modules |
| D | H | B | Voltage restored after short-circuit or overload on 24 V if faults occur in operation | Press FMR momentary-contact pushbutton: Flashing light changes to constant light |
| | | | Dynamic overload on 24 V | Check load on the power supply module. Possibly remove modules |
| D | B | B | Voltage restored after short circuit or overload on 5 V and 24 V if faults occur in operation | Press FMR momentary-contact pushbutton: Flashing light changes to constant light |
| D | B | B | Dynamic overload on 5 V and 24 V | Check load on the power supply module. Possibly remove modules |

D = LED is dark; L = LED lights up; F = LED flashing;

* If the power supply module does not start up again after a few seconds once the overload has been removed, remove power to the module for 5 minutes and then switch it on again. If the module still does not start up, you must replace it. This applies to 6ES7407-0KA01-0AA0, release 3 and for 6ES7407-0KR00-0AA0, release ≤ 5 .

** Depending on the short-circuit resistance

If either the 5 VDC or 24 VDC LEDs remains dark after switching on, the system has not powered up.

If either of the 5 VDC or 24 VDC LEDs of the PS 407 10AR remains dark for longer than 1 or 2 seconds after it is switched on, the power supply module will not start up.

The following power supply modules will switch off in the event of a short circuit or overload after 1 s to 3 s. The module will try to restart after no more than 3 s. If the error has been eliminated by then, the module will start up. This applies to the following modules:

| | | | |
|--------------|----------------------|--------------|---|
| PS 405 4A | (6ES7405-0DA01-0AA0) | PS 407 4A | (6ES7407-0DA01-0AA0) |
| PS 405 10A | (6ES7405-0KA01-0AA0) | PS 407 10A | (6ES7407-0KA01-0AA0), release ≥ 5 |
| PS 405 10A R | (6ES7405-0KR00-0AA0) | PS 407 10A R | (6ES7407-0KR00-0AA0), release ≥ 7 |
| PS 405 20A | (6ES7405-0RA01-0AA0) | PS 407 20A | (6ES7407-0RA01-0AA0) |

Overload at 24 V

In the event of overload at 24 V the output current is electronically limited to a value between 100% and 150% of the rated value. If the voltage then goes below the undervoltage threshold of 19.2 V ($-0/+ 5\%$ corresponds to 19.2 V to 20.16 V), the modules respond as follows:

- In the case of power supply modules with 4 A/0.5 A output current, the 24 V voltage is disconnected and reconnected at a repeat rate of approx. 0.5 s to 1 s until there is an output voltage that exceeds the undervoltage threshold.
- In the case of power supply modules with 10 A/1 A or 20 A/1 A output current, the voltage depends on the load impedance, and the module runs in characteristic curve mode.

After the overload has been eliminated, the voltage returns to the rated range and the green 24 V LED flashes. The CPU sets the EXTF LED (external fault) and saves the fault in the diagnostic buffer. You can trigger other responses, such as CPU STOP or a message to a control room, in OB 81 (power supply error). If OB 81 is not parameterized, the CPU continues as normal.

Overload at 5 V

In the event of an overload at 5V, the power supply modules with 10 A or 20 A output current can retain an output current of 16 A or 26 A for 300ms. The power supply modules with 4 A output current can retain an output current of 8 A for 300 ms. The CPU will then go to DEFECT afterwards. If the LED DC 5 V flashes on the power supply and is resettable with the FMR button, you will be able to perform a restart. The CPU will remain in STOP afterwards and will then require a memory reset.

BAF, BATT F

The following table applies to power supply modules with one battery if the BATT INDIC switch is in the BATT position. It shows the faults indicated and lists how to remedy the faults.

Table 3-9 BAF, BATT F; BATT INDIC LEDs on BATT

| LED | | Cause of Fault | Remedy |
|-----|--------|---|--|
| BAF | BATT F | | |
| H | H | Battery empty or missing No backup voltage available | Insert new battery. Press FMR momentary-contact pushbutton |
| D | H | Battery empty or missing | Insert new battery. Press FMR momentary-contact pushbutton |
| | | Battery has been stored for too long | Depassivate battery (see <i>Installation Manual</i> , Chapter 7) |
| H | D | Battery in order No backup voltage available (short circuit) | <ul style="list-style-type: none"> Fault after plugging in a module: Plugged-in module defective Fault after switching on: Remove all modules and plug in individually |
| D | D | Battery in order | – |

D = LED is dark; L = LED lights up;

BAF, BATT1F, BATT2F

The following table applies to power supply modules with two batteries if the BATT INDIC switch is in the 1BATT position. It shows the faults indicated and lists how to remedy the faults.

Nothing is indicated about the condition of any second battery that may be in use.

Table 3-10 BAF, BATT1F, BATT2F; BATT INDIC LEDs on 1BATT

| LED | | | Cause of Fault | Remedy |
|-----|--------|--------|---|--|
| BAF | BATT1F | BATT2F | | |
| H | H | D | Battery 1 empty or missing No backup voltage available | Insert new battery in compartment 1. Press FMR momentary-contact pushbutton |
| D | H | D | Battery 1 empty or missing | Insert new battery in compartment 1. Press FMR momentary-contact pushbutton |
| | | | Battery has been stored for too long | Depassivate battery (see <i>Installation Manual</i> , Chapter 7) |
| H | D | D | Battery 1 in order No backup voltage available (short circuit) | <ul style="list-style-type: none"> • Fault after plugging in a module: Plugged-in module defective • Fault after switching on: Remove all modules and plug in individually |
| D | D | D | Battery 1 in order | – |

D = LED is dark; L = LED lights up;

The following table applies to power supply modules with two batteries if the BATT INDIC switch is in the 2BATT position. It shows the faults indicated and lists how to remedy the faults.

Table 3-11 BAF, BATT1F, BATT2F; BATT INDIC LEDs on 2BATT

| LED | | | Cause of Fault | Remedy |
|-----|--------|--------|---|--|
| BAF | BATT1F | BATT2F | | |
| H | H | H | Both batteries are empty or missing. No backup voltage available | Insert new batteries in compartments 1 and 2 Press FMR momentary-contact pushbutton |
| D | H | H | Both batteries empty or missing | Insert new batteries in compartments 1 and 2 Press FMR momentary-contact pushbutton |
| H | H | D | Battery 1 empty or missing | Insert new battery in compartment 1. Press FMR momentary-contact pushbutton |
| | | | No backup voltage available (short circuit or overload) | <ul style="list-style-type: none"> Fault after plugging in a module: Plugged-in module defective Fault after switching on: Remove all modules and plug in individually |
| D | H | D | Battery 1 empty or missing | Insert new battery in compartment 1. Press FMR momentary-contact pushbutton |
| | | | Battery has been stored for too long | Depassivate battery (see <i>Installation Manual</i> , Chapter 7) |
| H | D | H | Battery 2 empty or missing | Insert new battery in compartment 2. Press FMR momentary-contact pushbutton |
| | | | No backup voltage available (short-circuit or overload) | <ul style="list-style-type: none"> Fault after plugging in a module: Plugged-in module defective Fault after switching on: Remove all modules and plug in individually |
| D | D | H | Battery 2 empty or missing | Insert new battery in compartment 2. Press FMR momentary-contact pushbutton |
| | | | Battery has been stored for too long | Depassivate battery (see <i>Installation Manual</i> , Chapter 7) |
| H | D | D | Both batteries in order. No backup voltage available (short circuit) | <ul style="list-style-type: none"> Fault after plugging in a module: Plugged-in module defective Fault after switching on: Remove all modules and plug in individually |
| D | D | D | Both batteries in order. | – |

D = LED is dark; L = LED lights up;

3.6 Power Supply Module PS 407 4A; (6ES7407-0DA00-0AA0)

Function

The PS 407 4 A power supply module is designed for connecting to an AC line voltage of 120/230 VAC and supplies 5 VDC/4 A and 24 VDC/0.5 A on the secondary side.

Controls and Indicators of the PS 407 4A

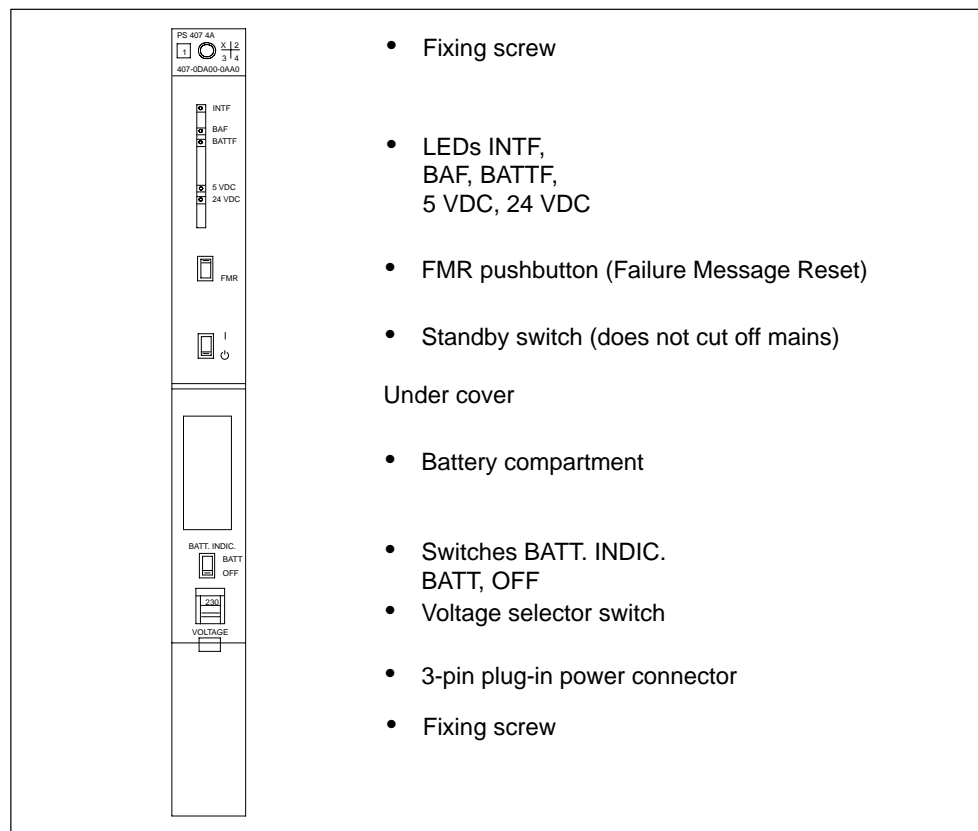

Figure 3-2 Controls and Indicators of the PS 407 4A

Technical Specifications of the PS 407 4A

| Programming Package | | Output Variables | |
|---|--|---|--|
| Associated programming package | As of STEP7 V 2.0 package | Output voltages | |
| Dimensions, Weight, and Cable Cross-Sections | | • Rated values | 5.1 VDC /24 VDC |
| Dimensions WxHxD (mm) | 25x290x217 | Output currents | |
| Weight | 0.78 kg | • Rated values | 5 VDC: 4 A 24 VDC: 0.5 A |
| Cable cross-section | 3x1.5 mm ² (litz wire with wire end ferrule with insulating collar; use only flexible sheath cable) | Max. residual ripple | 5 VDC: 50 mV _{SS} 24 VDC: 200 mV _{SS} |
| Cable diameter | 3 to 9 mm | Max. switching peaks | 5 VDC: 150 mV _S 24 VDC: 500 mV _S |
| Input Rating | | Idle conditions | 5 VDC: 100 mA Base load required 24 VDC: Idling-proof (no base load required) |
| Input voltage | | Other Parameters | |
| • Rated value | 120/230 VAC | Protection class in accordance with IEC 60536 | I, with protective grounding conductor |
| • Permitted range | 85 to 132 VAC / 170 to 264 VAC | Overvoltage category | II |
| System frequency | | Pollution severity | 2 |
| • Rated value | 50 / 60 Hz | Rated voltage U _e | Test Voltage |
| • Permitted range | 47 to 63 Hz | 0 < U _e ≤ 50 V | 700 VDC (secondary ↔ PE) |
| Rated input current | | 150 V < U _e ≤ 300 V | 2200 VDC (primary ↔ PE) |
| • At 120 VAC | 0.55 A | Buffering of power failures: | |
| • At 230 VAC | 0.31 A | • At 50 Hz | 4.5 ms to 7.5 ms |
| Inrush current | | • At 60 Hz | 6.5 ms to 8.5 ms |
| • With rated voltage of 264 V | Peak value 15 A Half-value width 2 ms | Power input | 46.5 W |
| • With rated voltage of 132 V | Peak value 18 A Half-value width 2 ms | Power loss | 13.9 W |
| Leakage current | < 3.5 mA | Backup current | Max. 100 µA at power off |
| Overvoltage resistance | In accordance with DIN VDE 0160, curve W2 | Backup battery (option) | 1 x Lithium AA, 3.6 V / 1.9 Ah |
| | | Protective separation to IEC 61131-2 | Yes |

3.7 Power Supply Module PS 407 4A; (6ES7407-0DA01-0AA0)

Function

The PS 407 4A power supply module is designed for connecting to either an AC line voltage of 85 to 264 V or a DC line voltage of 88 to 300 V and supplies 5 VDC/4 A and 24 VDC/0.5 A on the secondary side.

Controls and Indicators of the PS 407 4 A

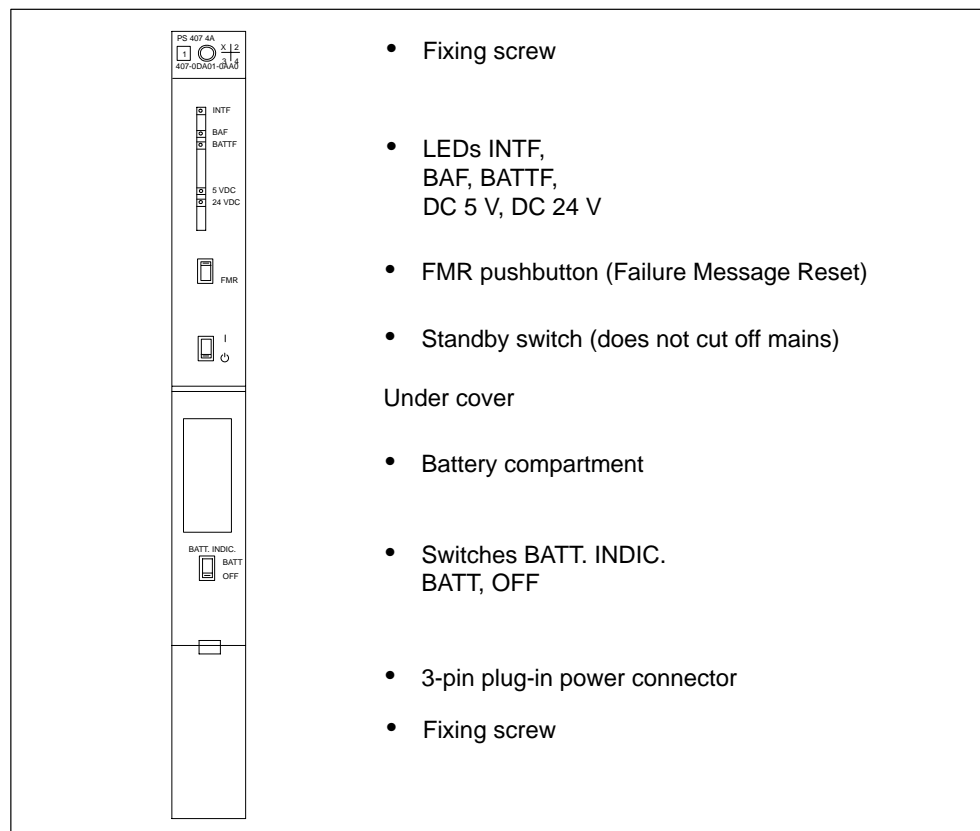

Figure 3-3 Controls and Indicators of the PS 407 4 A

Power connection

In contrast to the instructions on installing a power supply module in the “S7-400, M7-400 Programmable Controllers, Hardware and Installation” manual, an AC power connector is used for connecting the PS 407 4A to both an AC and DC supply.

Polarity Reversal of L+ and L-

The polarity reversal of L+ and L- with supply voltages of between 88 VDC and 300 VDC has no effect on the function of the power supply. The connection should be made as described in the instructions in the Installation Manual, Chapter 6.

Technical Specifications of the PS 407 4 A

| Dimensions, Weight, and Cable Cross-Sections | | Output Rating | |
|--|--|---|---|
| Dimensions WxHxD (mm) | 25x290x217 | Output voltages | |
| Weight | 0.76 kg | • Rated values | 5.1 VDC /24 VDC |
| Cable cross-section | 3x1.5 mm ² (litz wire with wire end ferrule with insulating collar; use only flexible sheath cable) | Output currents | |
| Cable diameter | 3 to 9 mm | • Rated values | 5 VDC: 4 A 24 VDC: 0.5 A |
| Input Rating | | Max. residual ripple | 5 VDC: 50 mV _{SS} 24 VDC: 200 mV _{SS} |
| Input voltage | | Max. switching peaks | 5 VDC: 150 mV _S 24 VDC: 500 mV _S |
| • Rated value | 110/230 VDC 120/230 VAC | Idle conditions | 5 VDC: 100 mA Base load required 24 VDC: Idling-proof (no base load required) |
| • Permitted range | 88 to 300 VDC, 85 to 264 VAC (long-range input) | Other Parameters | |
| System frequency | | Protection class in accordance with IEC 60536 | I, with protective grounding conductor |
| • Rated value | 50 / 60 Hz | Overvoltage category | II |
| • Permitted range | 47 to 63 Hz | Pollution severity | 2 |
| Rated input current | | Rated voltage U _e | Test Voltage |
| • At 120 VAC | 0.38 A | 0 < U _e ≤ 50 V | 700 VDC (secondary ↔ PE) |
| • At 120 VDC | 0.37 A | 150 V < U _e ≤ 300 V | 2200 VDC (primary ↔ PE) |
| • At 240 VAC | 0.22 A | Buffering of power failures: | >20 ms Complies with the NAMUR recommendation NE 21 of August 1998 at a repeat rate of 1 s |
| • At 240 VDC | 0.19 A | Power consumption 240 VDC | 52 W |
| Leakage current | < 3.5 mA | Power loss | 20 W |
| Overvoltage resistance | In accordance with DIN VDE 0160, curve W2 | Backup current | Max. 100 µA at power off |
| | | Backup battery (option) | 1 x Lithium AA, 3.6 V / 1.9 Ah |
| | | Protective separation to IEC 61131-2 | Yes |

3.8 Power Supply Modules

PS 407 10A; (6ES7407-0KA01-0AA0) and PS 407 10A R; (6ES7407-0KR00-0AA0)

Function

The power supply modules PS 407 10A (standard) and PS 407 10A R (redundancy-capable, see Section 3.2) are designed for connection to an AC line voltage of 85 to 264 V or DC line voltage of 88 to 300 V and supply 5 VDC/10 A and 24 VDC/1 A on the secondary side.

Controls and Displays of the PS 407 10A and thge PS 407 10A R

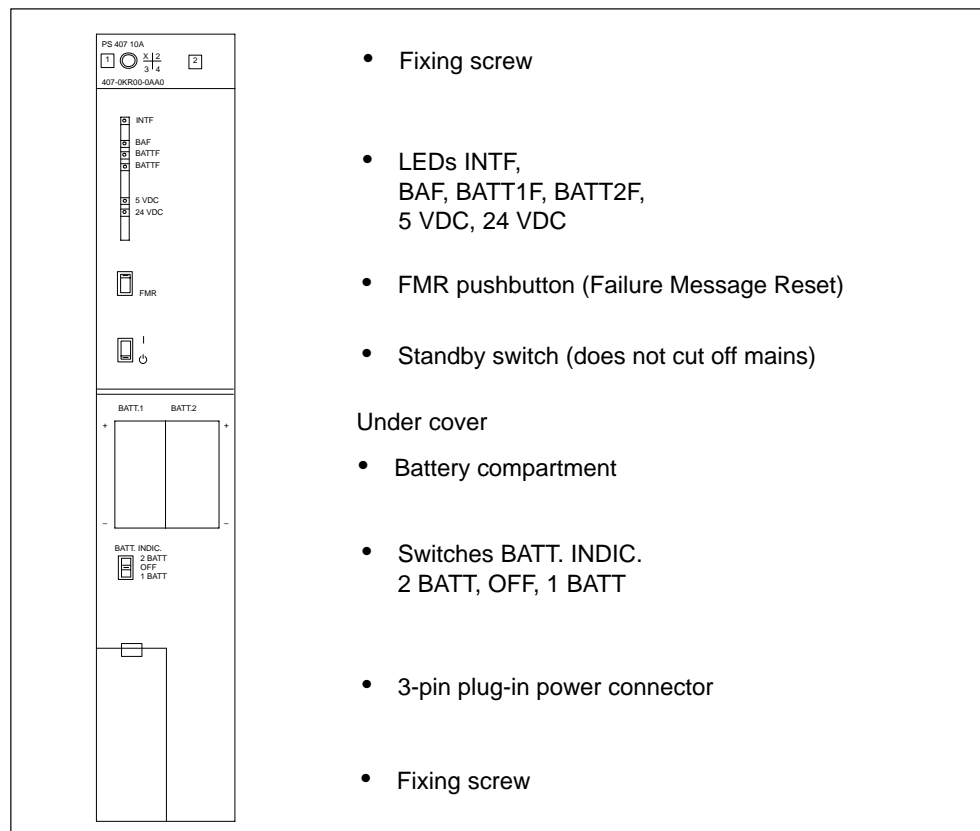

Figure 3-4 Controls and Displays of the PS 407 10A and PS 407 10A R

Power Connection

In contrast to the instructions on installing a power supply module described in the *"S7-400, M7-400 Programmable Controllers, Hardware and Installation"* manual, an AC connector is used for connecting the PS 407 10A and the PS 407 10A R to both an AC and a DC supply.

Polarity Reversal of L+ and L-

The polarity reversal of L+ and L- with supply voltages of between 88 VDC and 300 VDC has no effect on the function of the power supply. The connection should be made as described in the instructions in the Installation Manual, Chapter 6.

Technical Specifications of the PS 407 10A and the PS 407 10A R

| Dimensions, Weight, and Cable Cross-Sections | | Output Variables | |
|--|--|---|--|
| Dimensions WxHxD (mm) | 50x290x217 | Output voltages | |
| Weight | 1.36 kg | • Rated values | 5.1 VDC /24 VDC |
| Cable cross-section | 3 x 1.5 mm ² (litz wire with wire end ferrule with insulating collar; use only flexible sheath cable) | Output currents | |
| Cable diameter | 3 to 9 mm | • Rated values | 5 VDC: 10 A 24 VDC: 1.0 A |
| Input Rating | | Max. residual ripple | 5 VDC: 50 mV _{SS} 24 VDC: 200 mV _{SS} |
| Input voltage | | Max. switching peaks | 5 VDC: 150 mV _S 24 VDC: 500 mV _S |
| • Rated value | 110/230 VDC | Idle conditions | 5 VDC: 200 mA base load required 24 VDC: Idling-proof (no base load required) |
| • Permitted range | 120/230 VAC 88 to 300 VDC, 85 to 264 VAC (long-range input) | Other Parameters | |
| System frequency | | Protection class in accordance with IEC 60536 | I, with protective grounding conductor |
| • Rated value | 50 / 60 Hz | Overtoltage category | II |
| • Permitted range | 47 to 63 Hz | Pollution severity | 2 |
| Rated input current | | Rated voltage U _e | Test Voltage |
| • At 120 VAC | 1.2 A (0.9 A*) | 0 < U _e ≤ 50 V | 700 VDC (secondary ↔ PE) |
| • At 110 VDC | 1.2 A (1.0 A*) | 150 V < U _e ≤ 300 V | 2300 VDC (primary ↔ PE) |
| • At 230 VAC | 0.6 A (0.5 A*) | Buffering of power failures: | > 20 ms Complies with the NAMUR recommendation NE 21 of August 1998 at a repeat rate of 1 s |
| • At 230 VDC | 0.6 A (0.5 A*) | Power input | 105 W* |
| Starting current inrush | | Power loss | 29.7 W |
| • At 230 VAC | Peak value 230 A, half-value width 200 μs Peak value 63 A*, half-value width 1 ms* | Backup current | Max. 100 μA at power off |
| • At 300 VDC | Peak value 230 A, half-value width 200 μs Peak value 58 A*, half-value width 1 ms | Backup batteries (optional) | 2 x Lithium AA, 3.6 V / 1.9 Ah |
| Leakage current | < 3.5 mA | Protective separation to IEC 61131-2 | Yes |
| Overtoltage resistance | In accordance with DIN VDE 0160, curve W2 | | |

* PS 407 10A: As of version 5

* PS 407 10A R: As of version 7

3.9 Power Supply Module PS 407 20A; (6ES7407-0RA00-0AA0)

Function

The PS 407 20 A power supply module is designed for connecting to an AC line voltage of 120/230 VAC and supplies 5 VDC/20 A and 24 VDC/1 A on the secondary side.

Controls and Indicators of the PS 407 20 A

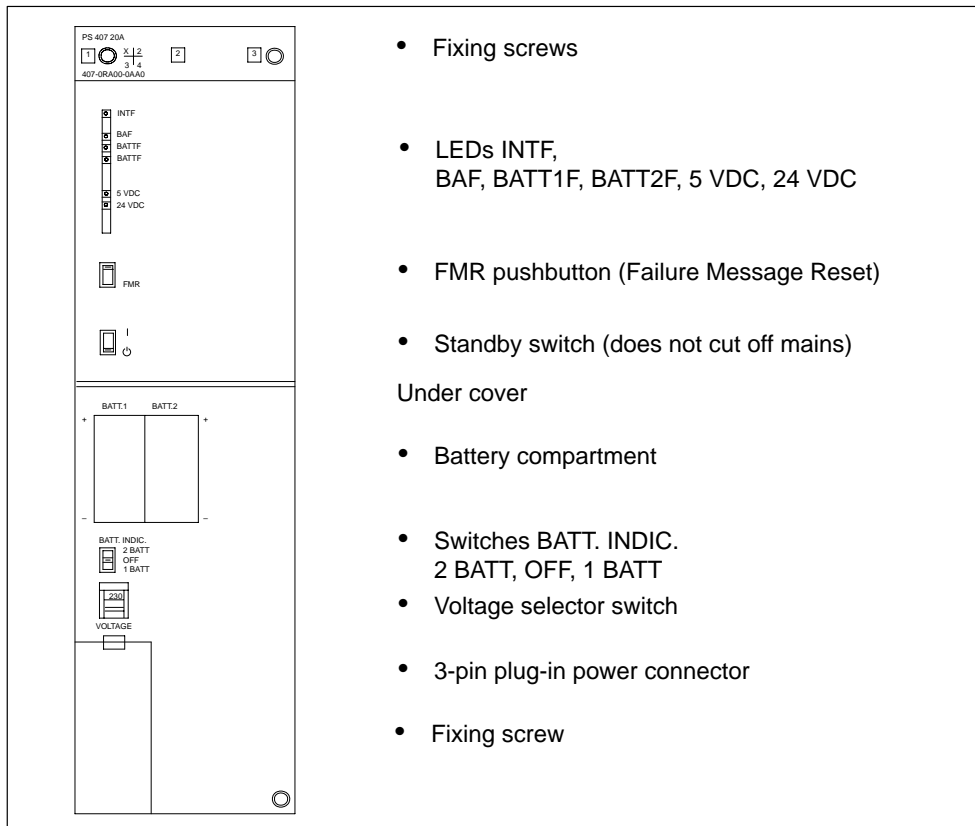

Figure 3-5 Controls and Displays of the PS 407 20A

Technical Specifications of the PS 407 20 A

| Programming Package | | Output Rating | |
|---|--|---|--|
| Associated programming package | As of STEP7 V 2.0 | Output voltages | |
| Dimensions, Weight, and Cable Cross-Sections | | • Rated values | 5.1 VDC /24 VDC |
| Dimensions WxHxD (mm) | 75x290x217 | Output currents | |
| Weight | 1.93 kg | • Rated values | 5 VDC: 20 A 24 VDC: 1.0 A |
| Cable cross-section | 3x1.5 mm ² (litz wire with wire end ferrule with insulating collar; use only flexible sheath cable) | Max. residual ripple | 5 VDC: 50 mV _{SS} 24 VDC: 200 mV _{SS} |
| Cable diameter | 3 to 9 mm | Max. switching peaks | 5 VDC: 150 mV _S 24 VDC: 500 mV _S |
| Input Rating | | Idle conditions | 5 VDC: 200 mA base load required 24 VDC: Idling-proof (no base load required) |
| Input voltage | | Other Parameters | |
| • Rated value | 120/230 VAC | Protection class in accordance with IEC 60536 | I, with protective grounding conductor |
| • Permitted range | 85 to 132 VAC / 170 to 264 VAC | Overvoltage category | II |
| System frequency | | Pollution severity | 2 |
| • Rated value | 50 / 60 Hz | Rated voltage U _e | Test Voltage |
| • Permitted range | 47 to 63 Hz | 0 < U _e ≤ 50 V | 700 VDC (secondary ↔ PE) |
| Rated input current | | 150 V < U _e ≤ 300 V | 2200 VDC (primary ↔ PE) |
| • At 120 VAC | 1.87 A | Buffering of power failures: | |
| • At 230 VAC | 1 A | • At 50 Hz | 4.5 ms to 7.5 ms |
| Starting current inrush | | • At 60 Hz | 6.5 ms to 8.5 ms |
| • Rated input current 264 V | Peak value 70 A | Power input | 162 W |
| • Rated input current 132 V | Half-value width 2 ms Peak value + 110 A/ – 65 A Half-value width 1.5 ms | Power loss | 35.6 W |
| Leakage current | < 3.5 mA | Backup current | Max. 100 μA at power off |
| Overvoltage resistance | In accordance with DIN VDE 0160, curve W2 | Backup batteries (optional) | 2 x Lithium AA, 3.6 V / 1.9 Ah |
| | | Protective separation to IEC 61131-2 | Yes |

3.10 Power Supply Module PS 407 20A; (6ES7407-0RA01-0AA0)

Function

The PS 407 20 A power supply module is designed for connecting to either an AC line voltage of 85 to 264 VAC or a DC line voltage of 88 to 300 VDC and supplies 5 VDC/20 A and 24 VDC/1 A on the secondary side.

Controls and Indicators of the PS 407 20 A

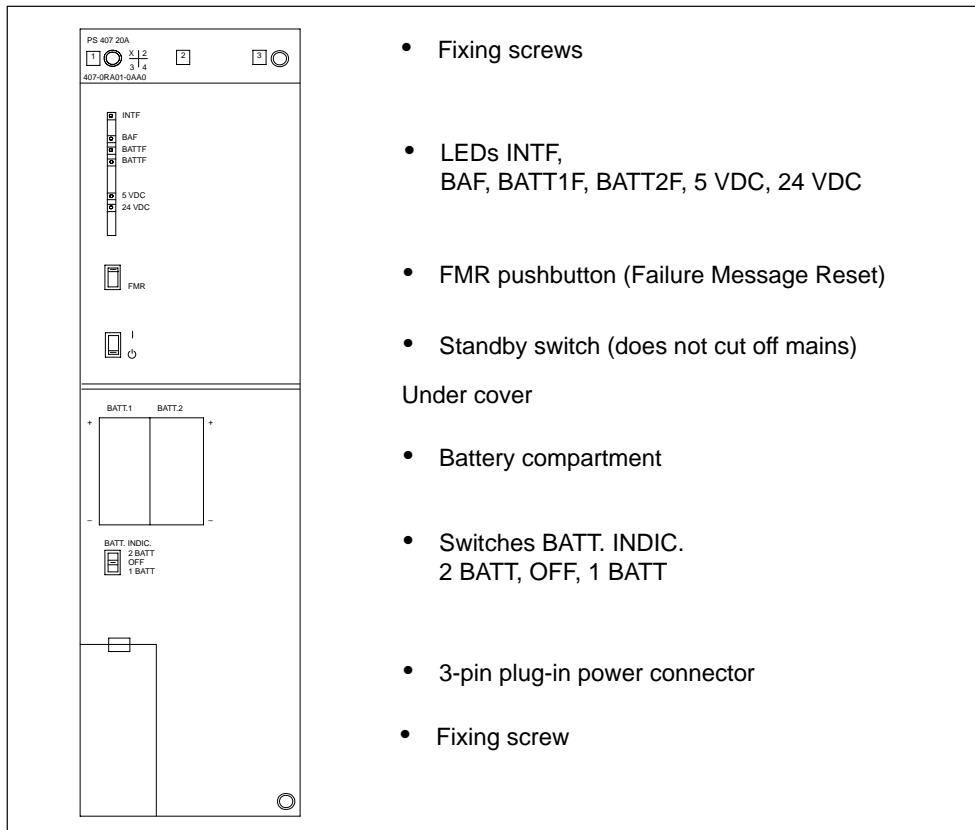

Figure 3-6 Controls and Indicators of the PS 407 20 A

Power Connection

In contrast to the instructions on installing a power supply module in the “S7-400, M7-400 Programmable Controllers, Hardware and Installation” manual, an AC power connector is used for connecting the PS 407 20A to both an AC and DC supply.

Polarity Reversal of L+ and L-

The polarity reversal of L+ and L- with supply voltages of between 88 VDC and 300 VDC has no effect on the function of the power supply. The connection should be made as described in the instructions in the Installation Manual, Chapter 6.

Technical Specifications of the PS 407 20 A

| Dimensions, Weight, and Cable Cross-Sections | | Output Rating | |
|--|--|---|--|
| Dimensions WxHxD (mm) | 75x290x217 | Output voltages | |
| Weight | 2.2 kg | • Rated values | 5.1 VDC /24 VDC |
| Cable cross-section | 3x1.5 mm ² (litz wire with wire end ferrule with insulating collar; use only flexible sheath cable) | Output currents | |
| Cable diameter | 3 to 9 mm | • Rated values | 5 VDC: 20 A 24 VDC: 1.0 A |
| Input Rating | | Max. residual ripple | 5 VDC: 50 mV _{SS} 24 VDC: 200 mV _{SS} |
| Input voltage | | Max. switching peaks | 5 VDC: 150 mV _S 24 VDC: 500 mV _S |
| • Rated value | 110/230 VDC | Idle conditions | 5 VDC: 200 mA base load required 24 VDC: Idling-proof (no base load required) |
| • Permitted range | 120/230 VAC 88 to 300 VDC, 85 to 264 VAC (long-range input) | Other Parameters | |
| System frequency | | Protection class in accordance with IEC 60536 | I, with protective grounding conductor |
| • Rated value | 50 / 60 Hz | Overvoltage category | II |
| • Permitted range | 47 to 63 Hz | Pollution severity | 2 |
| Rated input current | | Rated voltage U _e | Test Voltage |
| • At 120 VAC / 110 VDC | 1.5 A | 0 < U _e ≤ 50 V | 700 VDC (secondary ↔ PE) |
| • At 230 VAC / 230 VDC | 0.8 A | 150 V < U _e ≤ 300 V | 2300 VDC (primary ↔ PE) |
| Starting current inrush | Peak value 88 A half-value width 1.1 ms | Buffering of power failures: | > 20 ms Complies with the NAMUR recommendation NE 21 of August 1998 at a repeat rate of 1 s |
| Leakage current | < 3.5 mA | Power input | 168 W |
| Overvoltage resistance | In accordance with DIN VDE 0160, curve W2 | Power loss | 44 W |
| | | Backup current | Max. 100 μA at power off |
| | | Backup batteries (optional) | 2 x Lithium AA, 3.6 V / 1.9 Ah |
| | | Protective separation to IEC 61131-2 | Yes |

3.11 Power Supply Module PS 405 4A; (6ES7405-0DA00-0AA0)

Function

The PS 405 4 A power supply module is designed for connecting to a DC line voltage of 24 VDC and supplies 5 VDC/4 A and 24 VDC/0.5 A on the secondary side.

Controls and Indicators of the PS 405 4 A

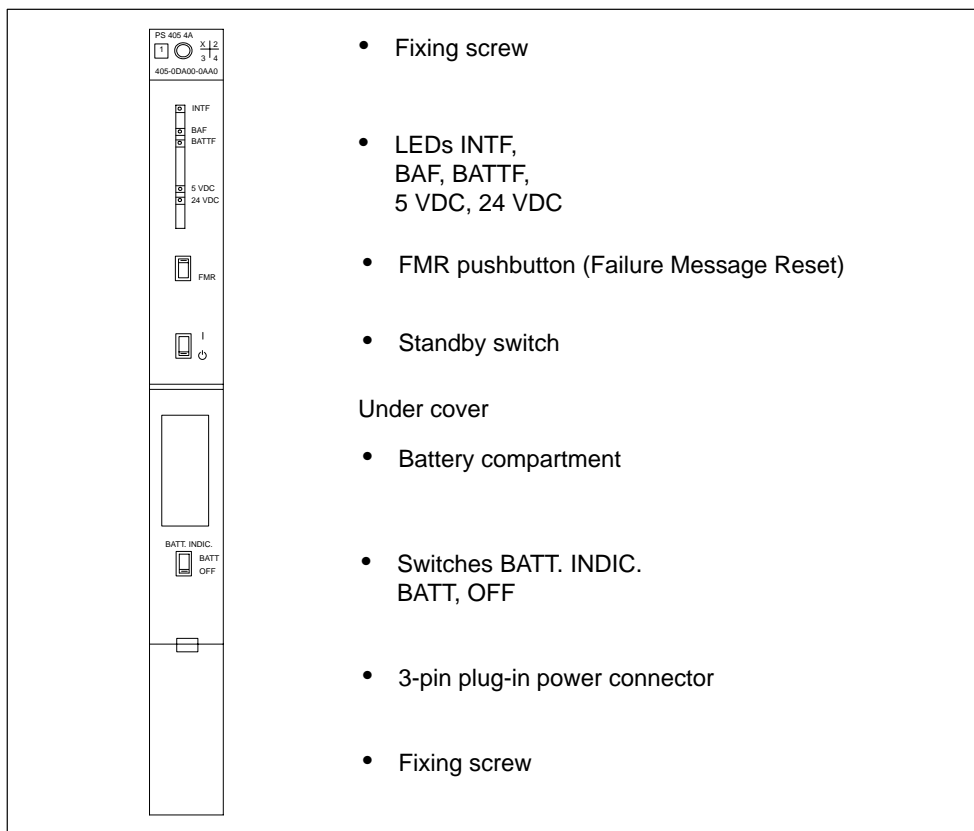

Figure 3-7 Controls and Indicators of the PS 405 4 A

Technical Specifications of the PS 405 4 A

| Programming Package | | Output Rating | |
|---|---|---|--|
| Associated programming package | As of STEP7 V 2.0 | Output voltages | |
| Dimensions, Weight, and Cable Cross-Sections | | • Rated values | 5.1 VDC /24 VDC |
| Dimensions WxHxD (mm) | 25x290x217 | Output currents | |
| Weight | 0.8 kg | • Rated values | 5 VDC: 4 A 24 VDC: 0.5 A |
| Cable cross-section | 3 x 1.5 mm ² (litz wire with wire end ferrule, use component conductor or flexible sheath cable) | Max. residual ripple | 5 VDC: 50 mV _{SS} 24 VDC: 200 mV _{SS} |
| Cable diameter | 3 to 9 mm | Max. switching peaks | 5 VDC: 150 mV _S 24 VDC: 500 mV _S |
| Input Rating | | Idle conditions | 5 VDC: 100 mA Base load required 24 VDC: Idling-proof (no base load required) |
| Input voltage | | Other Parameters | |
| • Rated value | 24 VDC | Protection class in accordance with IEC 60536 | I, with protective grounding conductor |
| • Permitted range | Static: 19.2 VDC to 30 VDC Dynamic: 18.5 VDC to 30.2 VDC | Overvoltage category | II |
| Rated input current | 2 A | Pollution severity | 2 |
| Starting current inrush | Peak value 27 A Half-value width 10 ms | Rated voltage U _e | Test Voltage |
| Overvoltage resistance | In accordance with DIN VDE 0160, curve B2 | 0 < U _e ≤ 50 V | 700 VDC (secondary ↔ PE) |
| | | 150 V < U _e ≤ 300 V | 2200 VDC (primary ↔ PE) |
| | | Buffering of power failures: | 4 ms to 5 ms |
| | | Power input | 48 W |
| | | Power loss | 16 W |
| | | Backup current | Max. 100 μA at power off |
| | | Backup battery (option) | 1 x Lithium AA, 3.6 V / 1.9 Ah |
| | | Protective separation to IEC 61131-2 | Yes |

3.12 Power Supply Module PS 405 4A; (6ES7405-0DA01-0AA0)

Function

The PS 405 4A power supply module is designed for connection to a DC line voltage of 19.2 to 72 VDC and supplies 5 VDC/4 A and 24 VDC/0.5 A on the secondary side.

Controls and Indicators of the PS 405 4 A

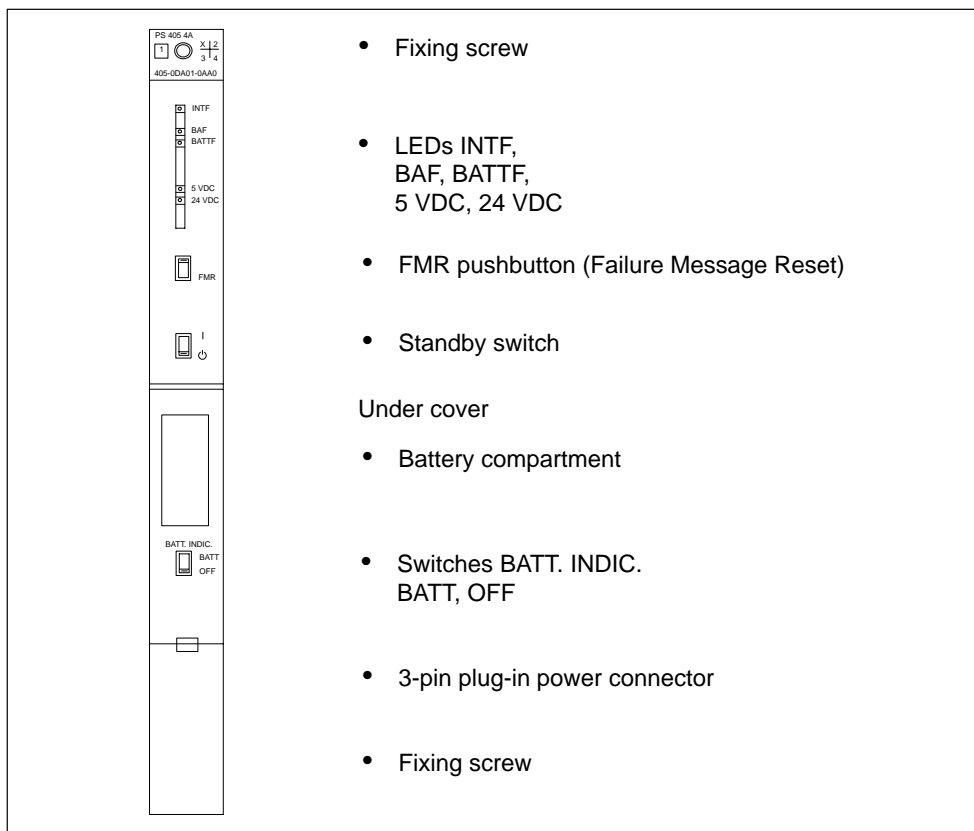

Figure 3-8 Controls and Indicators of the PS 405 4 A

Technical Specifications of the PS 405 4 A

| Dimensions, Weight, and Cable Cross-Sections | | Output Rating | |
|--|---|---|--|
| Dimensions WxHxD (mm) | 25x290x217 | Output voltages | |
| Weight | 0.76 kg | • Rated values | 5.1 VDC /24 VDC |
| Cable cross-section | 3 x 1.5 mm ² (litz wire with wire end ferrule; use component conductor or flexible sheath cable) | Output currents | |
| Cable diameter | 3 to 9 mm | • Rated values | 5 VDC: 4 A 24 VDC: 0.5 A |
| Input Rating | | Max. residual ripple | 5 VDC: 50 mV _{SS} 24 VDC: 200 mV _{SS} |
| Input voltage | | Max. switching peaks | 5 VDC: 150 mV _S 24 VDC: 500 mV _S |
| • Rated value | 24/48/60 VDC | Idle conditions | 5 VDC: 100 mA Base load required 24 VDC: Idling-proof (no base load required) |
| • Permitted range | Static: 19.2 VDC to 72 VDC Dynamic: 18.5 VDC to 75.5 VDC | Other Parameters | |
| Rated input current | 2 A/1 A/0.8 A | Protection class in accordance with IEC 60536 | I, with protective grounding conductor |
| Overvoltage resistance | In accordance with DIN VDE 0160, curve B2 | Overvoltage category | II |
| | | Pollution severity | 2 |
| | | Rated voltage U _e | Test Voltage |
| | | 0 < U _e ≤ 50 V | 700 VDC (secondary ↔ PE) |
| | | 150 V < U _e ≤ 300 V | 2200 VDC (primary ↔ PE) |
| | | Buffering of power failures: | > 20 ms Complies with the NAMUR recommendation NE 21 of August 1998 at a repeat rate of 1 s |
| | | Power consumption (24 VDC) | 48 W |
| | | Power loss | 16 W |
| | | Backup current | Max. 100 μA at power off |
| | | Backup battery (option) | 1 x Lithium AA, 3.6 V / 1.9 Ah |
| | | Protective separation to IEC 61131-2 | Yes |

3.13 Power Supply Module PS 405 10A; (6ES7405-0KA00-0AA0)

Function

The PS 405 10A power supply module is designed for connection to a DC line voltage of 24 VDC and supplies 5 VDC/10 A and 24 VDC/1 A on the secondary side.

Controls and Indicators of the PS 405 10 A

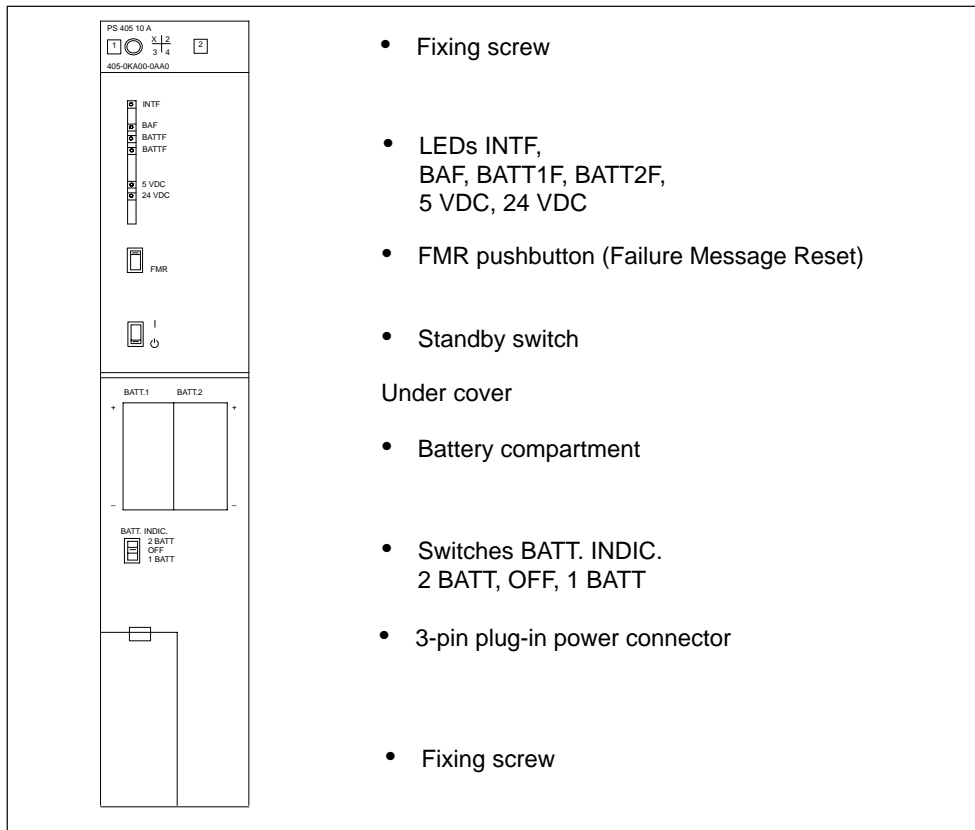

Figure 3-9 Controls and Indicators of the PS 405 10 A

Technical Specifications of the PS 405 10 A

| Programming Package | | Output Rating | |
|---|---|---|--|
| Associated programming package | As of STEP7 V 2.0 | Output voltages | |
| Dimensions, Weight, and Cable Cross-Sections | | • Rated values | 5.1 VDC /24 VDC |
| Dimensions WxHxD (mm) | 50x290x217 | Output currents | |
| Weight | 1.4 kg | • Rated values | 5 VDC: 10 A 24 VDC: 1.0 A |
| Cable cross-section | 3x1.5 mm ² (litz wire with wire end ferrule; use component conductor or flexible sheath cable) | Max. residual ripple | 5 VDC: 50 mV _{SS} 24 VDC: 200 mV _{SS} |
| Cable diameter | 3 to 9 mm | Max. switching peaks | 5 VDC: 150 mV _S 24 VDC: 500 mV _S |
| Input Rating | | Idle conditions | 5 VDC: 200 mA base load required 24 VDC: Idling-proof (no base load required) |
| Input voltage | | Other Parameters | |
| • Rated value | 24 VDC | Protection class in accordance with IEC 60536 | I, with protective grounding conductor |
| • Permitted range | Static: 19.2 VDC to 30 VDC Dynamic: 18.5 VDC to 30.2 VDC | Overvoltage category | II |
| Rated input current | 4.5 A | Pollution severity | 2 |
| Starting current inrush | Peak value 44 A Half-value width 20 ms | Rated voltage U _e | Test Voltage |
| Overvoltage resistance | In accordance with DIN VDE 0160, curve B2 | 0 < U _e ≤ 50 V | 700 VDC (secondary ↔ PE) |
| | | 150 V < U _e ≤ 300 V | 2200 VDC (primary ↔ PE) |
| | | Buffering of power failures: | 4 ms to 5 ms |
| | | Power input | 108 W |
| | | Power loss | 33 W |
| | | Backup current | Max. 100 μA at power off |
| | | Backup batteries (optional) | 2 x Lithium AA, 3.6 V / 1.9 Ah |
| | | Protective separation to IEC 61131-2 | Yes |

3.14 Power Supply Modules PS 405 10A; (6ES7405-0KA01-0AA0) and PS 405 10A R; (405-0KR00-0AA0)

Function

The power supply modules PS 405 10A (standard) and PS 405 10A R (redundancy-capable, see Section 3.2) are designed for connection to a DC line voltage of 19.2 VDC to 72 VDC and supply 5 VDC/10 A and 24 VDC/1 A on the secondary side.

Controls and Displays of the PS 405 10A and the PS 405 10A R

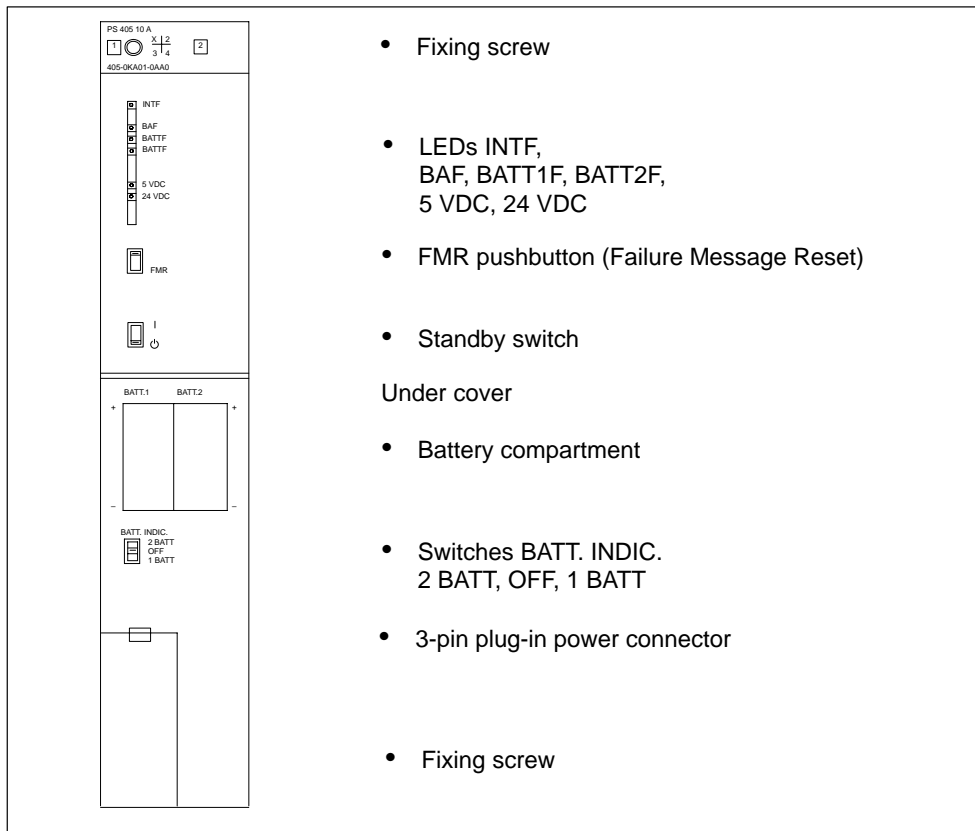

Figure 3-10 Controls and Displays of the PS 405 10A and PS 405 10A R

Technical Specifications of the PS 405 10A and the PS 405 10A R

| Dimensions, Weight, and Cable Cross-Sections | | Output Rating | |
|--|---|---|--|
| Dimensions WxHxD (mm) | 50x290x217 | Output voltages | |
| Weight | 1.4 kg | • Rated values | 5.1 VDC/24 VDC |
| Cable cross-section | 3 x 1.5 mm ² (litz wire with wire end ferrule, use component conductor or flexible sheath cable) | Output currents | |
| Cable diameter | 3 to 9 mm | • Rated values | 5 VDC: 10 A 24 VDC: 1.0 A |
| Input Rating | | Max. residual ripple | 5 VDC: 50 mV _{SS} 24 VDC: 200 mV _{SS} |
| Input voltage | | Max. switching peaks | 5 VDC: 150 mV _S 24 VDC: 500 mV _S |
| • Rated value | 24/48/60 VDC | Idle conditions | 5 VDC: 200 mA base load required 24 VDC: Idling-proof (no base load required) |
| • Permitted range | Static: 19.2 VDC to 72 VDC Dynamic: 18.5 VDC to 75.5 VDC | Other Parameters | |
| Rated input current | 4.3 A/2.1 A/1.7 A | Protection class in accordance with IEC 60536 | I, with protective grounding conductor |
| Starting current inrush | Peak value 18 A Half-value width 20 ms | Overvoltage category | II |
| Overvoltage resistance | In accordance with DIN VDE 0160, curve B2 | Pollution severity | 2 |
| | | Rated voltage U _e | Test Voltage |
| | | 0 < U _e ≤ 50 V | 700 VDC (secondary ↔ PE) |
| | | 150 < U _e ≤ 300 V | 2300 VDC (primary ↔ PE) |
| | | Buffering of power failures: | > 20 ms Complies with the NAMUR recommendation NE 21 of August 1998 at a repeat rate of 1 s |
| | | Power input | 104 W |
| | | Power loss | 29 W |
| | | Backup current | Max. 100 μA at power off |
| | | Backup batteries (optional) | 2 x Lithium AA, 3.6 V / 1.9 Ah |
| | | Protective separation to IEC 61131-2 | Yes |

3.15 Power Supply Module PS 405 20A; (6ES7405-0RA00-0AA0)

Function

The PS 405 20 A power supply module is designed for connecting to a DC line voltage of 24 VDC and supplies 5 VDC/20 A and 24 VDC/1 A on the secondary side.

Controls and Indicators of the PS 405 20 A

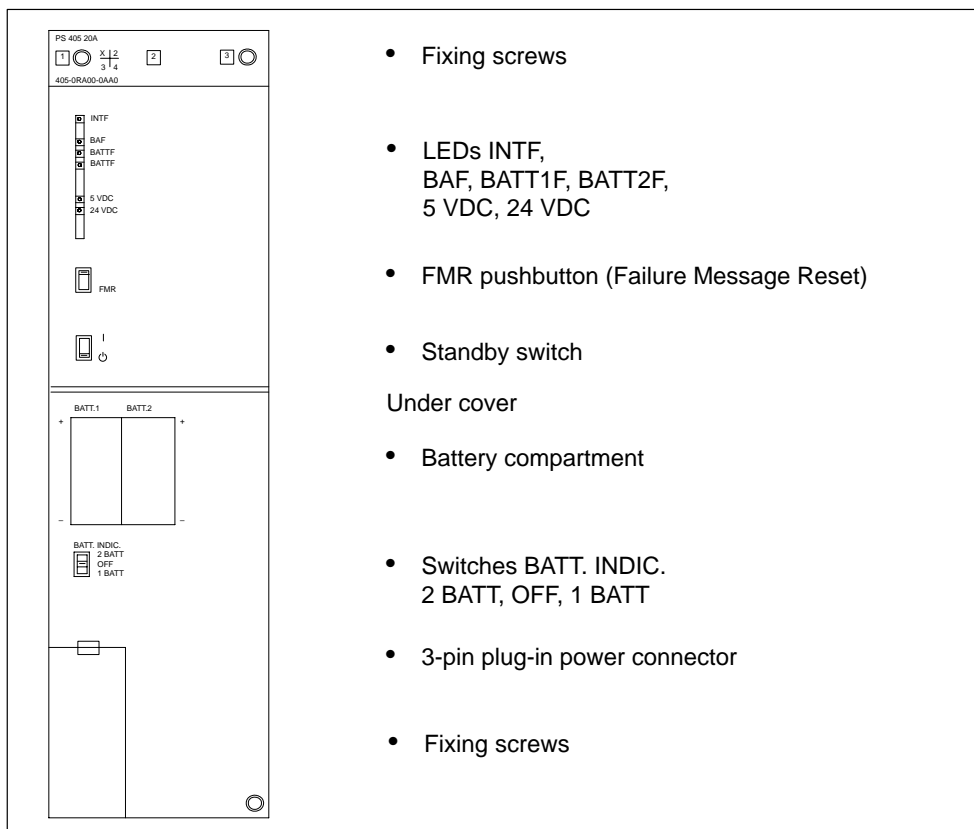

Figure 3-11 Controls and Indicators of the PS 405 20 A

Technical Specifications of the PS 405 20 A

| Programming Package | | Output Rating | |
|---|---|---|--|
| Associated programming package | As of STEP7 V 2.0 | Output voltages | |
| Dimensions, Weight, and Cable Cross-Sections | | • Rated values | 5.1 VDC/24 VDC |
| Dimensions WxHxD (mm) | 75x290x217 | Output currents | |
| Weight | 2.2 kg | • Rated values | 5 VDC: 20 A 24 VDC: 1.0 A |
| Cable cross-section | 3x1.5 mm ² (litz wire with wire end ferrule; use component conductor or flexible sheath cable) | Max. residual ripple | 5 VDC: 50 mV _{SS} 24 VDC: 200 mV _{SS} |
| Cable diameter | 3 to 9 mm | Max. switching peaks | 5 VDC: 150 mV _S 24 VDC: 500 mV _S |
| Input Rating | | Idle conditions | 5 VDC: 200 mA base load required 24 VDC: Idling-proof (no base load required) |
| Input voltage | | Other Parameters | |
| • Rated value | 24 VDC | Protection class in accordance with IEC 60536 | I, with protective grounding conductor |
| • Permitted range | Static: 19.2 VDC to 30 VDC Dynamic: 18.5 VDC to 30.2 VDC | Overvoltage category | II |
| Rated input current | 7.2 A | Pollution severity | 2 |
| Starting current inrush | Peak value 48 A Half-value width 25 ms | Rated voltage U _e | Test Voltage |
| Overvoltage resistance | In accordance with DIN VDE 0160, curve B2 | 0 < U _e ≤ 50 V | 700 VDC (secondary ↔ PE) |
| | | 150 V < U _e ≤ 300 V | 2200 VDC (primary ↔ PE) |
| | | Buffering of power failures: | 4 ms to 5 ms |
| | | Power input | 172.8 W |
| | | Power loss | 46.8 W |
| | | Backup current | Max. 100 μA at power off |
| | | Backup batteries (optional) | 2 x Lithium AA, 3.6 V / 1.9 Ah |
| | | Protective separation to IEC 61131-2 | Yes |

3.16 Power Supply Module PS 405 20A; (6ES7405-0RA01-0AA0)

Function

The PS 405 20A power supply module is designed for connection to a DC line voltage of 19.2 VDC to 72 VDC and supplies 5 VDC/20 A and 24 VDC/1 A on the secondary side.

Controls and Indicators of the PS 405 20 A

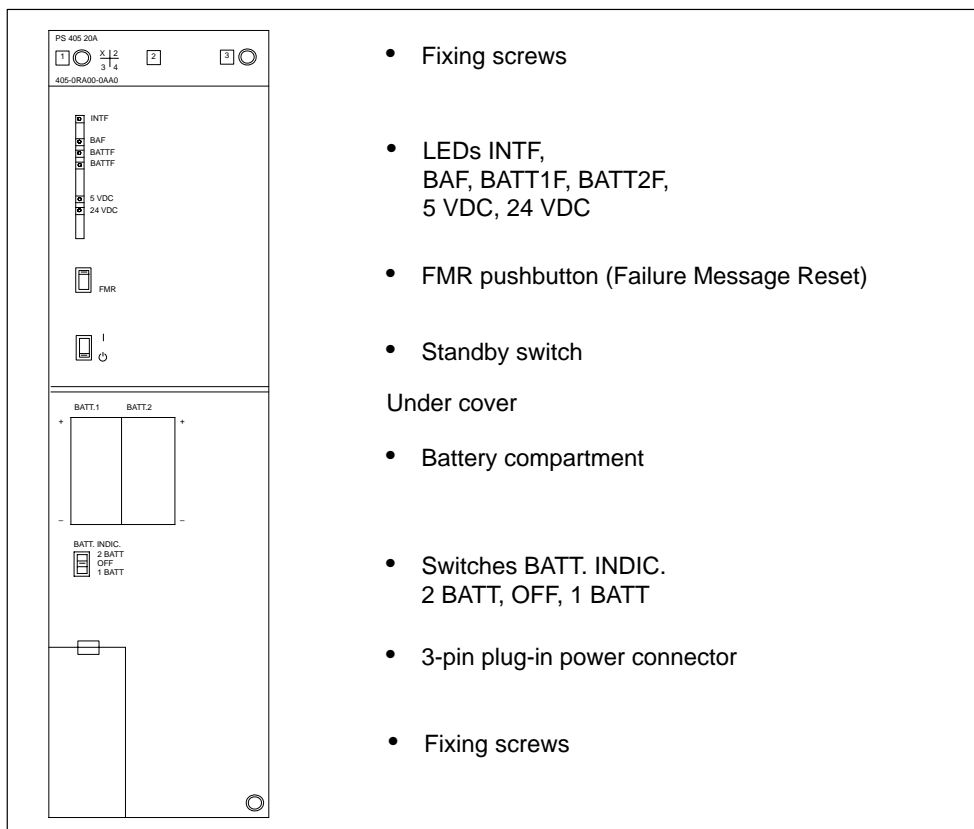

Figure 3-12 Controls and Indicators of the PS 405 20 A

Technical Specifications of the PS 405 20 A

| Dimensions, Weight, and Cable Cross-Sections | | Output Rating | |
|--|---|---|--|
| Dimensions WxHxD (mm) | 75x290x217 | Output voltages | |
| Weight | 2.2 kg | • Rated values | 5.1 VDC/24 VDC |
| Cable cross-section | 3x1.5 mm ² (litz wire with wire end ferrule; use component conductor or flexible sheath cable) | Output currents | |
| Cable diameter | 3 to 9 mm | • Rated values | 5 VDC: 20 A 24 VDC: 1.0 A |
| Input Rating | | Max. residual ripple | 5 VDC: 50 mV _{SS} 24 VDC: 200 mV _{SS} |
| Input voltage | | Max. switching peaks | 5 VDC: 150 mV _S 24 VDC: 500 mV _S |
| • Rated value | 24/48/60 VDC | Idle conditions | 5 VDC: 200 mA base load required 24 VDC: Idling-proof (no base load required) |
| • Permitted range | Static: 19.2 VDC to 72 VDC Dynamic: 18.5 VDC to 75.5 VDC | Other Parameters | |
| Rated input current | 7.3 A/3.45 A/2.75 A | Protection class in accordance with IEC 60536 | I, with protective grounding conductor |
| Starting current inrush | Peak value 56 A half-value width 1.5 ms | Overvoltage category | II |
| Overvoltage resistance | In accordance with DIN VDE 0160, curve B2 | Pollution severity | 2 |
| | | Rated voltage U _e | Test Voltage |
| | | 0 < U _e ≤ 50 V | 700 VDC (secondary ↔ PE) |
| | | 150 V < U _e ≤ 300 V | 2300 VDC (primary ↔ PE) |
| | | Buffering of power failures: | > 20 ms Complies with the NAMUR recommendation NE 21 of August 1998 at a repeat rate of 1 s |
| | | Power input | 175 W |
| | | Power loss | 51 W |
| | | Backup current | Max. 100 μA at power off |
| | | Backup batteries (optional) | 2 x Lithium AA, 3.6 V / 1.9 Ah |
| | | Protective separation to IEC 61131-2 | Yes |

Digital Modules

4

Structure of the Chapter

The present chapter is subdivided into the following subjects:

1. Overview containing the modules that are available here and a description
2. Information that is generally valid – in other words, relating to all digital modules (for example, parameter assignment and diagnostics)
3. Information that refers to specific modules (for example, characteristics, diagram of connections and block diagram, technical specifications and special characteristics of the module):
 - a) for digital input modules
 - b) for digital output modules

Additional Information

Appendix A describes the structure of the parameter records (data records 0, 1 and 128) in the system data. You must be familiar with this structure if you want to modify the parameters of the modules in the *STEP 7* user program.

Appendix B describes the structure of the diagnostic data (data records 0, 1) in the system data. You must be familiar with this structure if you want to evaluate the diagnostic data of the modules in the *STEP 7* user program.

Chapter Overview

| Section | Description | Page |
|---------|--|------|
| 4.1 | Module Overview | 4-3 |
| 4.2 | Sequence of Steps from Choosing to Commissioning the Digital Module | 4-5 |
| 4.3 | Digital Module Parameter Assignment | 4-6 |
| 4.4 | Diagnostics of the Digital Modules | 4-9 |
| 4.5 | Interrupts of the Digital Modules | 4-13 |
| 4.6 | Input Characteristic Curve for Digital Inputs | 4-15 |
| 4.7 | Digital Input Module SM 421; DI 32 × 24 VDC; (6ES7421-1BL00-0AA0) | 4-17 |
| 4.8 | Digital Input Module SM 421; DI 32 × 24 VDC; (6ES7421-1BL01-0AA0) | 4-20 |
| 4.9 | Digital Input Module SM 421; DI 16 × 24 VDC; (6ES7421-7BH00-0AB0) | 4-23 |
| 4.10 | Digital Input Module SM 421; DI 16 × 24 VDC; (6ES7421-7BH01-0AB0) | 4-32 |
| 4.11 | Digital Input Module SM 421; DI 16 × 120 VAC; (6ES7421-5EH00-0AA0) | 4-41 |
| 4.12 | Digital Input Module SM 421; DI 16 × 24/60 VUC; (6ES7421-7DH00-0AB0) | 4-44 |
| 4.13 | Digital Input Module SM 421; DI 16 × 120/230 VUC; (6ES7421-1FH00-0AA0) | 4-50 |
| 4.14 | Digital Input Module SM 421; DI 16 × 120/230 VUC; (6ES7421-1FH20-0AA0) | 4-53 |
| 4.15 | Digital Input Module SM 421; DI 32 × 120 VUC; (6ES7421-1EL00-0AA0) | 4-56 |
| 4.16 | Digital Output Module SM 422; DO 16 × 24 VDC/2 A; (6ES7422-1BH10-0AA0) | 4-59 |
| 4.17 | Digital Output Module SM 422; DO 16 × 24 VDC/2 A; (6ES7422-1BH11-0AA0) | 4-62 |
| 4.18 | Digital Output Module SM 422; DO 16 × 20-125 VDC/1.5 A; (6ES7422-5EH10-0AB0) | 4-65 |
| 4.19 | Digital Output Module SM 422; DO 32 × 24 VDC/0.5 A; (6ES7422-1BL00-0AA0) | 4-70 |
| 4.20 | Digital Output Module SM 422; DO 32 × 24 VDC/0.5 A; (6ES7422-7BL00-0AB0) | 4-73 |
| 4.21 | Digital Output Module SM 422; DO 8 × 120/230 VAC/5 A; (6ES7422-1FF00-0AA0) | 4-79 |
| 4.22 | Digital Output Module SM 422; DO 16 × 120/230 VAC/2 A; (6ES7422-1FH00-0AA0) | 4-83 |
| 4.23 | Digital Output Module SM 422; DO 16 × 20-120 VAC/2 A; (6ES7422-5EH00-0AB0) | 4-87 |
| 4.24 | Relay Output Module SM 422; DO 16 × 30/230 VUC/Rel. 5 A; (6ES7422-1HH00-0AA0) | 4-91 |

4.1 Module Overview

Introduction

The following tables summarize the most important characteristics of the digital modules. This overview is intended to make it easy to choose the suitable module for your task.

Table 4-1 Digital Input Modules: Characteristics at a Glance

| Module Characteristics | SM 421; DI 32 × 24 VDC (-1BL0x-) | SM 421; DI 16 × 24 VDC (-7BH00-) | SM 421; DI 16 × 120 VAC (-5EH00-) | SM 421; DI 16 × 24/ 60 VUC (-7DH00-) | SM 421; DI 16 × 120 /230 VUC (-1FH00-) | SM 421; DI 16 × 120 /230 VUC (-1FH20-) | SM 421; DI 32 × 120 VUC (-1EL00-) |
|--|---|---|--|--|---|--|--|
| Number of inputs | 32 DI; isolated in groups of 32 | 16 DI; isolated in groups of 8 | 16 DI; isolated in groups of 1 | 16 DI; isolated in groups of 1 | 16 DI; isolated in groups of 4 | 16 DI; isolated in groups of 4 | 32 DI; isolated in groups of 8 |
| Rated input voltage | 24 VDC | 24 VDC | 120 VAC | 24 VUC to 60 VUC | 120 VAC/ 230 VDC | 120/230 VUC | 120 VAC/ VDC |
| Suitable for... | Switches Two-wire proximity switches (BEROs) | | | | | | |
| Programmable diagnostics | No | Yes | No | Yes | No | No | No |
| Diagnostic Interrupt | No | Yes | No | Yes | No | No | No |
| Hardware interrupt upon edge change | No | Yes | No | Yes | No | No | No |
| Adjustable input delays | No | Yes | No | Yes | No | No | No |
| Substitute value output | – | Yes | – | – | – | – | – |
| Special Features | High packaging density | Quick and with interrupt capability | Channel-specific isolation | Interrupt capability with low, variable voltages | For high, variable voltages | For high, variable voltages Input characteristic curve to IEC 61131-2 | High packaging density |

Table 4-2 Digital Output Modules: Characteristics at a Glance

| Module \ Characteristics | SM 422; DO 16 × 24 VDC/2 A (-1BH1x) | SM 422; DO 16 × 20-125 VDC/1.5 A (-5EH10) | SM 422; DO 32 × 24 VDC/ 0.5 A (-1BL00) | SM 422; DO 32 × 24 VDC/0.5 A (-7BL00) | SM 422; DO 8 × 120/230 VAC/5 A (-1FF00) | SM 422; DO 16 × 120/230 VAC/2 A (-1FH00) | SM 422; DO 16 × 20-120 VAC/2 A (-5EH00) |
|---------------------------------|-------------------------------------|--|--|--|---|--|---|
| Number of outputs | 16 DO; isolated in groups of 8 | 16 DO; isolated and reverse polarity protection in groups of 8 | 32 DO; isolated in groups of 32 | 32 DO; isolated in groups of 8 | 8 DO; isolated in groups of 1 | 16 DO; isolated in groups of 4 | 16 DO; isolated in groups of 1 |
| Output current | 2 A | 1.5 A | 0.5 A | 0.5 A | 5 A | 2 A | 2 A |
| Rated load voltage | 24 VDC | 20 to 125 VDC | 24 VDC | 24 VDC | 120/230 VAC | 120/230 VAC | 20 to 120 VAC |
| Programmable diagnostics | No | Yes | No | Yes | No | No | Yes |
| Diagnostic Interrupt | No | Yes | No | Yes | No | No | Yes |
| Substitute value output | No | Yes | No | Yes | No | No | Yes |
| Special Features | For high currents | For variable voltages | High packaging density | Particularly quick and with interrupt capability | For high currents with channel-specific isolation | – | For variable currents with channel-specific isolation |

Table 4-3 Relay Output Module: Characteristics at a Glance

| Module \ Characteristics | SM 422; DO 16 × 30/230 VUC/Rel. 5 A (-1HH00) |
|--------------------------|--|
| Number of Outputs | 16 outputs, isolated in groups of 8 |
| Load Voltage | 125 VDC 230 VAC |
| Special Features | – |

4.2 Sequence of Steps from Choosing to Commissioning the Digital Module

Introduction

The following table contains the tasks that you have to perform one after the other to commission digital modules successfully.

The sequence of steps is a suggestion, but you can perform individual steps either earlier or later (for example, assign parameters to the module) or install other modules or install, commission etc. other modules in between times.

Sequence of Steps

Table 4-4 Sequence of Steps from Choosing to Commissioning the Digital Module

| Step | Procedure | Refer To... |
|------|---|--|
| 1. | Select the module | Section 4.1 and specific module section from Section 4.8 |
| 2. | Install the module in the SIMATIC S7 network | "Installation" section in the manual for the programmable controller being used: <ul style="list-style-type: none"> • S7-400/M7-400 Programmable Controllers, Hardware and Installation |
| 3. | Assign parameters to module | Section 4.3 and, if necessary, the specific module section as of Section 4.7 |
| 4. | Commission configuration | Section on commissioning in the manual for the programmable controller being used: <ul style="list-style-type: none"> • S7-400/M7-400 Programmable Controllers, Hardware and Installation |
| 5. | If commissioning was not successful, diagnose configuration | Section 4.4 |

4.3 Digital Module Parameter Assignment

Introduction

Digital modules can have different characteristics. You can set the characteristics of some modules by means of parameter assignment.

Tools for Parameter Assignment

You assign parameters to digital modules in *STEP 7*. You must perform parameter assignment in STOP mode of the CPU.

When you have set all the parameters, download the parameters from the programming device to the CPU. When there is a transition from STOP to RUN mode, the CPU transfers the parameters to the individual digital modules.

Static and dynamic parameters

The parameters are divided into static and dynamic parameters.

Set the static parameters in STOP mode of the CPU, as described above.

In addition, you can modify the dynamic parameters in the current user program in an S7 programmable controller by means of SFCs. Note, however, that after a change from RUN → STOP, STOP → RUN of the CPU, the parameters set in *STEP 7* apply again. You will find a description of the parameter assignment of modules in the user program in Appendix A.

Table 4-5 Static and dynamic parameters of the digital modules

| Parameter | Settable with | CPU Operating Mode |
|-----------|----------------------------|--------------------|
| Static | PG (STEP 7 HWCONFIG) | STOP |
| Dynamic | PG (STEP 7 HWCONFIG) | STOP |
| | SFC 55 in the user program | RUN |

4.3.1 Parameters of the Digital Input Modules

The parameterized digital input modules use a subset of the parameters and ranges of values listed in the table below, depending on functionality. Refer to the section on a particular digital module, starting from Section 4.7, to find out which subset it is capable of using.

Don't forget that some digital modules have different time delays after parameter assignment.

The default settings apply if you have not performed parameter assignment in *STEP 7*.

Table 4-6 Parameters of the Digital Input Modules

| Parameter | Value Range | Default ² | Parameter Type | Scope |
|--------------------------------------|--|----------------------|----------------|---------|
| Enable | | | | |
| • Diagnostic interrupt ¹⁾ | Yes/no | No | Dynamic | Module |
| • Hardware interrupt ¹⁾ | Yes/no | No | | |
| • Destination CPU for interrupt | 1 to 4 | – | Static | Module |
| Diagnostics | | | | |
| • Wire break | Yes/no | No | Static | Channel |
| • No load voltage L+/sensor supply | Yes/no | No | | |
| Trigger for hardware interrupt | | | | |
| • Rising (positive) edge | Yes/no | No | Dynamic | Channel |
| • Falling (negative) edge | Yes/no | No | | |
| Input delay | 0.1 ms (DC) 0.5 ms (DC) 3 ms (DC) 20 ms (DC/AC) | 3 (DC) | Static | Channel |
| Reaction to error | Substitute a value (SV) Keep last value (KLV) | SV | Dynamic | Module |
| Substitute "1" | Yes/no | No | Dynamic | Channel |

- 1) If you use the module in ER-1/ER-2, you must set this parameter to "No" because the interrupt lines are not available in ER-1/ER-2.
- 2) Only in the CC (central controller) is it possible to start up the digital modules with the default settings and without HWCONFIG support.

4.3.2 Parameters of the Digital Output Modules

The parameterized digital output modules use a subset of the parameters and ranges of values listed in the table below, depending on the functionality. Refer to the section on the relevant digital module, starting from Section 4.16, to find out which subset it is capable of using.

The default settings apply if you have not performed parameter assignment in *STEP 7*.

Table 4-7 Parameters of the Digital Output Modules

| Parameter | Value Range | Default ²⁾ | Parameter Type | Scope |
|---|--|----------------------------|----------------|---------|
| Enable <ul style="list-style-type: none"> Diagnostic interrupt¹⁾ Destination CPU for interrupt | Yes/no | No | Dynamic | Module |
| | 1 to 4 | – | Static | Module |
| Reaction to CPU-STOP | Substitute a value (SV) Keep last value (KLV) | SV | Dynamic | Module |
| Diagnostics <ul style="list-style-type: none"> Wire break No load voltage L+ Short circuit to M Short circuit to L+ Fuse blown | Yes/no Yes/no Yes/no Yes/no Yes/no | No No No No No | Static | Channel |
| Substitute "1" | Yes/no | No | Dynamic | Channel |

- 1) If you use the module in ER-1/ER-2, you must set this parameter to "No" because the interrupt lines are not available in ER-1/ ER-2.
- 2) Only in the CC (central controller) is it possible to start up the digital modules with the default settings and without support from HWCONFIG.

4.4 Diagnostics of the Digital Modules

Programmable and Non-Programmable Diagnostic Messages

In diagnostics, we make a distinction between programmable and non-programmable diagnostic messages.

You obtain programmable diagnostic messages only if you have enabled diagnostics by parameter assignment. You perform parameter assignment in the "Diagnostics" parameter block in *STEP 7* (refer to Section 5.7).

Non-programmable diagnostic messages are always made available by the digital module irrespective of diagnostics being enabled.

Actions Following Diagnostic Message in *STEP 7*

Each diagnostic message leads to the following actions:

- The diagnostic message is entered in the diagnostics of the digital module, forwarded to the CPU and can be read out by the user program.
- The fault LED on the digital module lights up.
- If you have parameterized "Enable Diagnostic Interrupt" in *STEP 7*, a diagnostic interrupt is triggered and OB 82 is called (refer to Section 4.5).

Reading Out Diagnostic Messages

You can read out detailed diagnostic messages by means of SFCs in the user program (refer to the Appendix "Diagnostic Data of Signal Modules").

You can view the cause of the error in *STEP 7* in the module diagnosis (refer to the *STEP 7* online help system).

Diagnostics Using the INTF and EXTF LEDs

Some digital modules indicate faults by means of their two fault LEDs INTF (internal fault) and EXTF (external fault). The LEDs go out when all the internal and external faults have been eliminated.

Refer to the technical specifications of the modules, starting at Section 4.7, to find out which digital modules have these fault LEDs.

Diagnostic Messages of the Digital Modules

The table below gives an overview of the diagnostic messages for the digital modules with diagnostics capability.

You can find out which diagnostic message each module is capable of in the Appendix entitled “Diagnostic Data of the Signal Modules”.

Table 4-8 Diagnostic Messages of the Digital Modules

| Diagnostic Message | LED | Scope of the Diagnosis | Parameters Can Be Assigned |
|-----------------------------------|-----------|------------------------|----------------------------|
| Module problem | INTF/EXTF | Module | No |
| Internal malfunction | INTF | Module | No |
| External malfunction | EXTF | Module | No |
| Channel error present | INTF/EXTF | Module | No |
| External auxiliary supply missing | EXTF | Module | No |
| Front connector missing | EXTF | Module | No |
| Module not parameterized. | INTF | Module | No |
| Wrong parameters | INTF | Module | No |
| Channel information available | INTF/EXTF | Module | No |
| STOP mode | – | Module | No |
| Internal voltage failure | INTF | Module | No |
| EPROM error | INTF | Module | No |
| Hardware interrupt lost | INTF | Module | No |
| Parameter assignment error | INTF | Channel | No |
| Short-circuit to M | EXTF | Channel | Yes |
| Short-circuit to L+ | EXTF | Channel | Yes |
| Wire break | EXTF | Channel | Yes |
| Fuse blown | INTF | Channel | Yes |
| Sensor supply missing | EXTF | Channel/channel group | Yes |
| No load voltage L+ | EXTF | Channel/channel group | Yes |

Note

A prerequisite for detecting the errors indicated by programmable diagnostic messages is that you have assigned parameters to the digital module accordingly in *STEP 7*.

Causes of Errors and Remedial Measures for Digital Modules

Table 4-9 Diagnostic Messages of the Digital Modules, Causes of Errors and Remedial Measures

| Diagnostic Message | Possible Error Cause | Remedy |
|---|--|--|
| Module malfunction | An error detected by the module has occurred | - |
| Internal malfunction | The module has detected an error within the programmable controller | - |
| External malfunction | The module has detected an error outside the programmable controller | - |
| There is a channel error | Indicates that only certain channels are faulty | - |
| No external auxiliary voltage | Voltage required to operate the module is missing (load voltage, sensor supply) | Supply missing voltage |
| No front connector | Jumper between connections 1 and 2 in the front connector missing | Install jumper |
| Parameters have not been assigned to the module | The module requires the information as to whether it should work with system default parameters or with your parameters | Message queued after power-on until parameter transmission by the CPU has been completed; parameterize the module, as required |
| Wrong parameters | One parameter or the combination of parameters is not plausible | Reassign module parameter |
| Channel information available | Channel error present; the module can supply additional channel information | - |
| Operating mode STOP | Module was not parameterized and the first module cycle has not been completed | If after rebooting the CPU all the input values are in the intermediate memory, this message is reset |
| Internal voltage failure | Module is defective | Replace module |
| EPROM error | Module is defective | Replace module |
| Hardware interrupt lost | The module cannot send an interrupt, since the previous interrupt was not acknowledged; configuration error possible | Change the interrupt handling in the CPU (change priority for interrupt OB; shorten interrupt program) |
| Parameter assignment error | Incorrect parameters transferred to the module (for example, impossible input delay); the corresponding channel is deactivated | Reassign module parameter |
| Short circuit to M | Overload of output | Eliminate overload |
| | Short-circuit of output to M | Check the wiring of the outputs |
| Short circuit to L+ | Short circuit of output to L+ | Check the wiring of the outputs |

Table 4-9 Diagnostic Messages of the Digital Modules, Causes of Errors and Remedial Measures, continued

| Diagnostic Message | Possible Error Cause | Remedy |
|---------------------------|--|--|
| Wire break | Lines interrupted | Close circuit |
| | No external sensor supply | Wire sensors with 10 to 18 kΩ |
| | Channel not connected (open) | Disable the "Diagnostics – Wire Break" parameter for the channel in <i>STEP 7</i> Connect channel |
| Fuse blown | One or more fuses on the module has blown and caused this fault. | Remove the overload and replace the fuse |
| No sensor supply | Overload of sensor supply | Eliminate overload |
| | Short circuit of sensor supply to M | Eliminate short circuit |
| No load voltage L+ | Power supply L+ to module missing | Feed in supply voltage L+ |
| | Fuse in module is defective | Replace module |

4.5 Interrupts of the Digital Modules

Introduction

This section describes the interrupt behavior of the digital modules. The following interrupts exist:

- Diagnostic Interrupt
- Hardware interrupt

Note that not all digital modules have interrupt capability or they are only capable of a subset of the interrupts described here. Refer to the technical specifications of the modules, starting at Section 4.7, to find out which digital modules have interrupt capability.

The OBs and SFCs mentioned below can be found in the online help system for *STEP 7*, where they are described in greater detail.

Enabling Interrupts

The interrupts are not preset – in other words, they are inhibited without appropriate parameter assignment. You enable the interrupts in *STEP 7* (refer to Section 5.7).

Special Feature: The Module is Inserted in ER-1/ER-2

Note

If you use the digital module in ER-1/ER-2, you must set the parameters for enabling all the interrupts to “No” because the interrupt lines are not available in ER-1/ER-2.

Diagnostic Interrupt

If you have enabled diagnostic interrupts, then active error events (initial occurrence of the error) and departing error events (message after troubleshooting) are reported by means of an interrupt.

The CPU interrupts the execution of the user program and processes the diagnostic interrupt block (OB 82).

In the user program, you can call SFC 51 or SFC 59 in OB 82 to obtain more detailed diagnostic information from the module.

The diagnostic information is consistent until such time as OB 82 is exited. When OB 82 is exited, the diagnostic interrupt is acknowledged on the module.

Hardware Interrupt

A digital input module can trigger a hardware interrupt for each channel at a rising or falling edge, or both, of a signal status change.

You perform parameter assignment for each channel separately. It can be modified at any time (in RUN mode using the user program).

Pending hardware interrupts trigger hardware interrupt processing in the CPU (OB 40 to OB 47). The CPU interrupts the execution of the user program or of the priority classes with low priority.

In the user program of the hardware interrupt OB (OB 40 to OB 47) you can specify how the programmable controller is to respond to an edge change. When the hardware interrupt OB is exited, the hardware interrupt is acknowledged on the module.

For each channel the digital input module can buffer an interrupt that has not been triggered. If no higher priority run-time levels are waiting to be processed, the buffered interrupts (of all modules) are serviced one after the other by the CPU according to the order in which they occurred.

Hardware Interrupt Lost

In an interrupt has been buffered for a channel and another interrupt occurs on that channel before it has been processed by the CPU, a diagnostic interrupt "hardware interrupt lost" is triggered.

More interrupts on this channel are not acquired until processing of the interrupt buffered on this channel has been executed.

Interrupt-Triggering Channels

The interrupt-triggering channels are stored in the local data of the hardware interrupt OBs (in the start information of the corresponding OB). The start information is two words long (bits 0 to 31). The bit number is the channel number. Bits 16 to 31 are not assigned.

4.6 Input Characteristic Curve for Digital Inputs

IEC 61131, Type 1 and Type 2

The IEC 61131 standard requires the following for the input current:

- In the case of type 2, an input current of ≥ 2 mA already at + 5 V
- In the case of type 1, an input current of ≥ 0.5 mA already at + 5 V

EN 60947-5-2, Two-Wire BEROs

The standard for BEROs (EN 60947-5-2) specifies that there can be a current of ≤ 1.5 mA for BEROs in the "0" signal state.

The input current of the module in the "0" signal state is decisive for the operation of two-wire BEROs. This must be in accordance with BERO requirements.

Input Characteristic Curve for Digital Inputs

As long as the current flowing into the module remains ≤ 1.5 mA, the module recognizes this as a "0" signal.

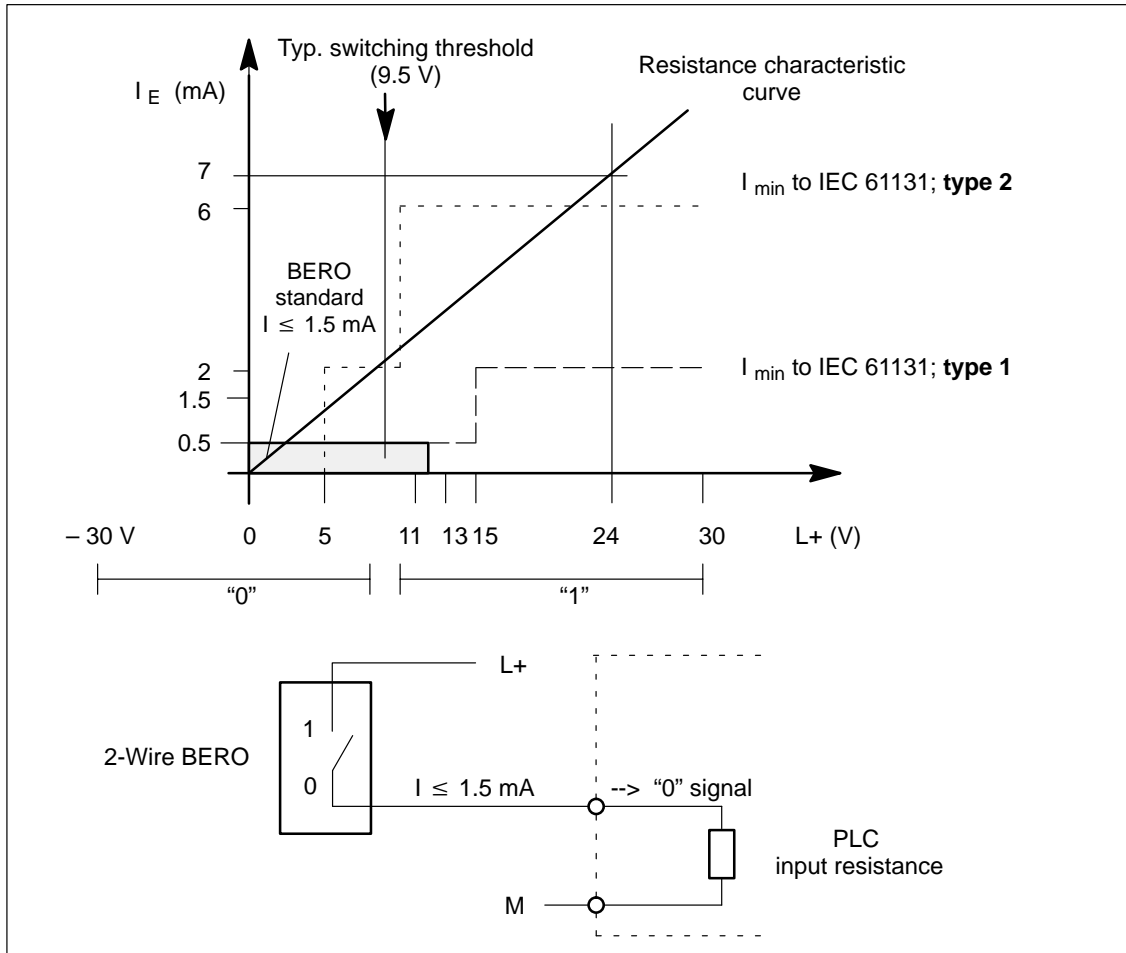

Figure 4-1 Input Characteristic Curve for Digital Inputs

IEC 61131, Type 1 in the Case of the Digital Input Module (6ES7421-1BL01-0AA0)

The input current in the case of the digital input module (6ES7421-1BL01-0AA0) reaches 1.5 mA only above the +5 V switching threshold but under the switching threshold of the module (typ. 9.5 V). Therefore only type 1 can be specified with the IEC 61131 standard.

4.7 Digital Input Module SM 421; DI 32 × 24 VDC (6ES7421-1BL00-0AA0)

Characteristics

The SM 421;DI 32 x 24 VDC is a digital input module with the following features:

- 32 inputs, isolated in a group of 32. In other words, all inputs share the same chassis ground.
- Rated load voltage: 24 VDC
- Suitable for switches and 2-wire proximity switches (BEROs, IEC 61131; type 2).

The status LEDs indicate the process status.

Functional Expansion as of Version 03

The lower limit of the rated input range is increased at signal "0" from –3 to –30 V.

The rated input voltage for signal "0" is thus: –30 V to 5 V

**Terminal Assignment and Block Diagram of the Digital Input Module SM 421;
DI 32 x 24 VDC**

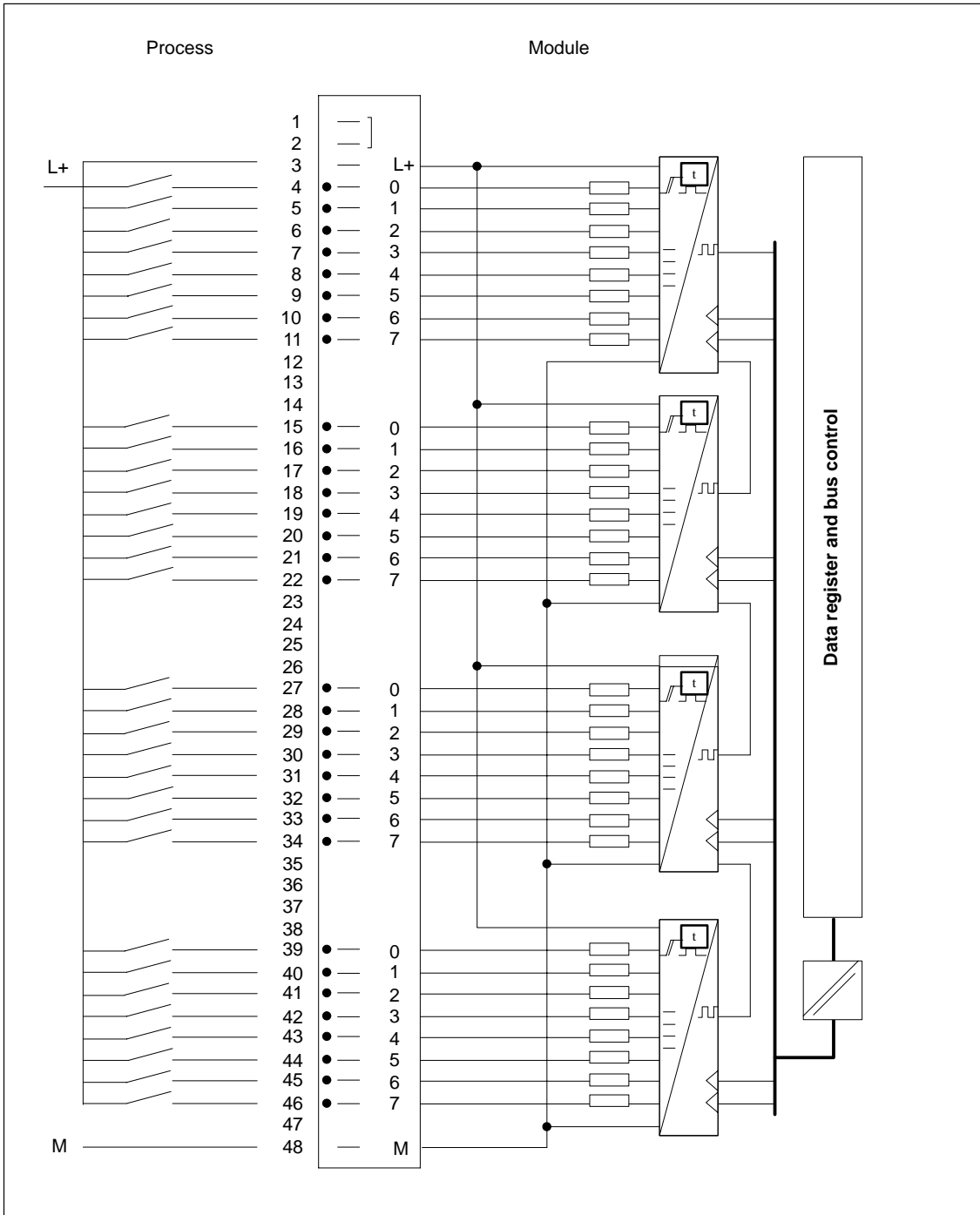

Figure 4-2 Terminal Assignment and Block Diagram of the SM 421; DI 32 × 24 VDC

Technical Specifications of the SM 421; DI 32 x 24 VDC

| Programming package | | Status, Interrupts, Diagnostics | |
|--|--------------------|---------------------------------|-------------------------------|
| Associated programming package | As of STEP 7 V 2.0 | Status display | Green LED per channel |
| Dimensions and Weight | | Interrupts | None |
| Dimensions W × H × D (in millimeters) | 25 × 290 × 210 | Diagnostic functions | None |
| Weight | Approx. 600 g | Substitute value can be applied | No |
| Data for Specific Module | | Sensor Selection Data | |
| Number of inputs | 32 | Input voltage | |
| Length of cable | | • Rated value | 24 VDC |
| • Unshielded | Max. 600 m | • For signal "1" | 11 V to 30 V |
| • Shielded | Max. 1000 m | • For signal "0" | -3 V to 5 V |
| Voltages, Currents, Potentials | | | -30 V to 5 V as of version 03 |
| Power rated voltage of the electronics L+ | 24 VDC | Input current | |
| • Reverse polarity protection | Yes | • At signal "1" | 6 mA to 8 mA |
| • Power failure buffering | None | Input delay | |
| Number of inputs that can be triggered simultaneously | 32 | • At "0" to "1" | 1.2 ms to 4.8 ms |
| Isolation | | • At "1" to "0" | 1.2 ms to 4.8 ms |
| • Between channels and backplane bus | Yes | Input characteristic curve | To IEC 61131; type 2 |
| • Between channels and power supply of the electronics | No | Connection of two-wire BEROs | Possible |
| • Between the channels | No | • Permitted bias current | Max. 2.5 mA |
| Permitted potential difference | | | |
| • Between the different circuits | 75 VDC / 60 VAC | | |
| Insulation tested with | | | |
| • Channels against backplane bus and load voltage L+ | 500 VDC | | |
| Current consumption | | | |
| • From the backplane bus | Max. 30 mA | | |
| • From supply voltage L+ | Max. 30 mA | | |
| Power dissipation of the module | Typ. 6 W | | |

4.8 Digital Input Module SM 421; DI 32 × 24 VDC; (6ES7421-1BL01-0AA0)

Characteristics

The digital input module SM 421; DI 32 × 24 VDC has the following features:

- 32 inputs, isolated in a group of 32
- 24 VDC rated input voltage
- Suitable for switches and two/three/four-wire proximity switches (BEROs, IEC 61131; type 1)

The status LEDs indicate the process status.

Notice

If you use the module with the order number 6ES7421-1BL01-0AA0 as a replacement for the module with the order number 6ES7421-1BL00-0AA0, you can leave PIN 3 wired. If you run modules 6ES7421-1BL00-0AA0 and 6ES7421-1BL01-0AA0 involved in mutual exchange, you have to wire and supply PIN 3 as described in Section 4.7.

Terminal Assignment and Block Diagram of the SM 421; DI 32 × 24 VDC

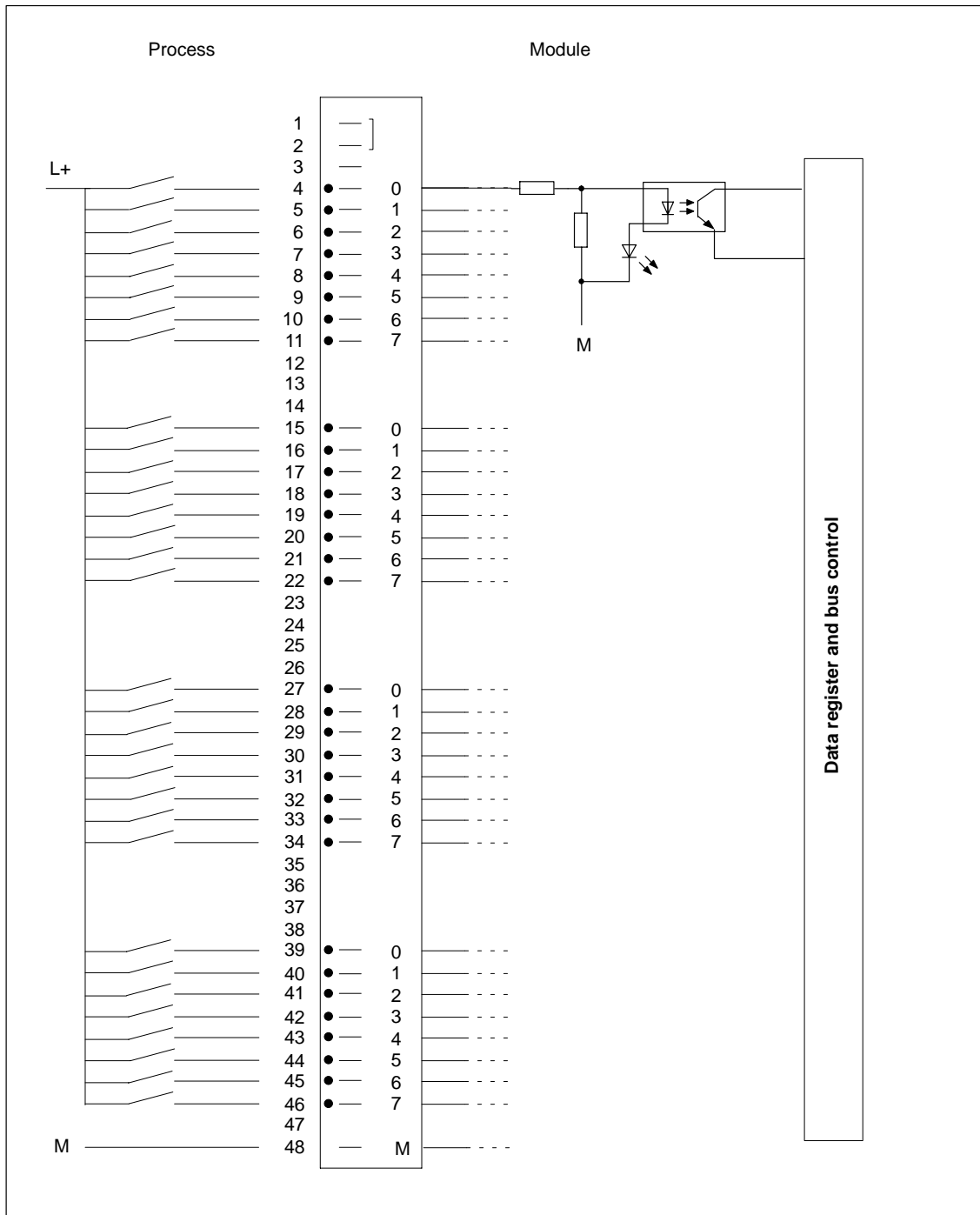

Figure 4-3 Terminal Assignment and Block Diagram of the SM 421; DI 32 × 24 VDC

Technical Specifications of the SM 421; DI 32 x 24 VDC

| Dimensions and Weight | | Status, Interrupts, Diagnostics | |
|---|-----------------|---------------------------------|-----------------------|
| Dimensions W × H × D (in millimeters) | 25 × 290 × 210 | Status display | Green LED per channel |
| Weight | Approx. 500 g | Interrupts | None |
| Data for Specific Module | | Diagnostic functions | None |
| Number of inputs | 32 | Substitute value can be applied | No |
| Length of cable | | Data for Selecting a Sensor | |
| • Unshielded | Max. 600 m | Input voltage | |
| • Shielded | Max. 1000 m | • Rated value | 24 VDC |
| Voltages, Currents, Potentials | | • For signal "1" | 13 V to 30 V |
| Power rated voltage of the electronics L+ | Not required | • For signal "0" | -30 V to 5 V |
| Number of inputs that can be triggered simultaneously | 32 | Input current | |
| Isolation | | • At signal "1" | 7 mA |
| • Between channels and backplane bus | Yes | Input delay | |
| • Between the channels | No | • At "0" to "1" | 1.2 ms to 4.8 ms |
| Permitted potential difference | | • At "1" to "0" | 1.2 ms to 4.8 ms |
| • Between the different circuits | 75 VDC / 60 VAC | Input characteristic curve | To IEC 61131; type 1 |
| Insulation tested with | | Connection of two-wire BEROs | Possible |
| • Channels against backplane bus and load voltage L+ | 500 VDC | • Permitted bias current | Max. 1.5 mA |
| Current consumption | | | |
| • From the backplane bus | Max. 20 mA | | |
| Power dissipation of the module | Typ. 6 W | | |

4.9 Digital Input Module SM 421; DI 16 × 24 VDC; (6ES7421-7BH00-0AB0)

Characteristics

The digital input module SM 421; DI 16 × 24 VDC has the following features:

- 16 inputs, isolated in 2 groups of 8
- 24 VDC rated input voltage
- Suitable for switches and two/three/four-wire proximity switches (BEROs, IEC 61131; type 2)
- 2 short-circuit-proof sensor supplies for 8 channels each
- External redundant power supply possible to supply sensors
- "Sensor supply (Vs) O.K." status display
- Group error display for internal faults (INTF) and external faults (EXTF)
- Programmable diagnostics
- Programmable diagnostic interrupt
- Programmable hardware interrupt
- Programmable input delays
- Parameterizable substitute values in the input range

The status LEDs indicate the process status.

Terminal Assignment and Block Diagram of the SM 421; DI 16 × 24 VDC

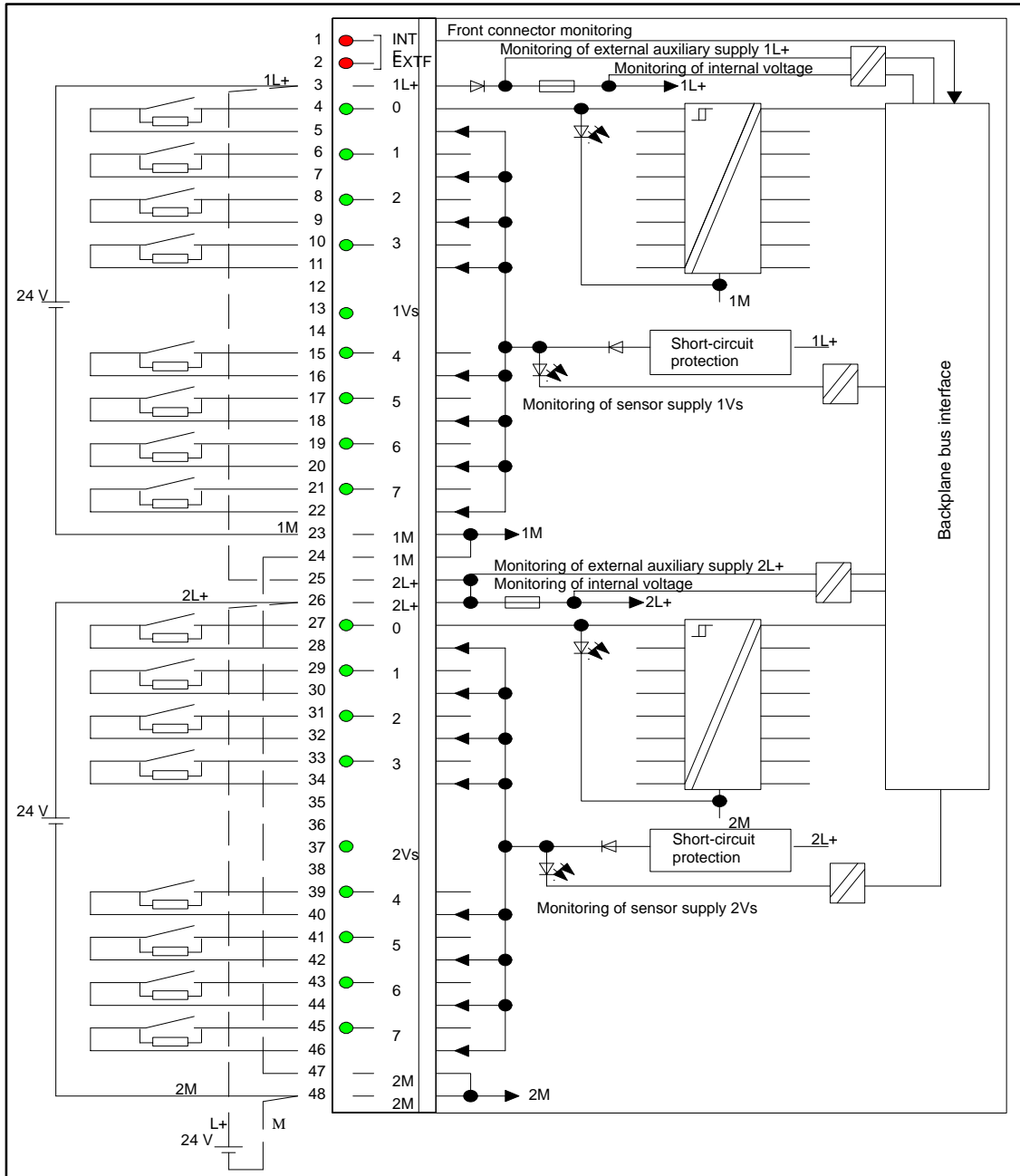

Figure 4-4 Terminal Assignment and Block Diagram of the SM 421; DI 16 × 24 VDC

Terminal Assignment Diagram for Redundant Supply of Sensors

The figure below shows how sensors can additionally be supplied by means of V_s with a redundant voltage source – for example, via another module).

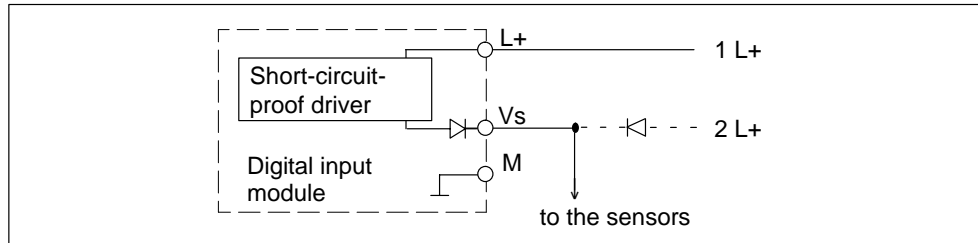

Figure 4-5 Terminal Assignment Diagram for the Redundant Supply of Sensors of the SM 421; DI 16 × 24 VDC

Technical Specifications of the SM 421; DI 16 × 24 VDC

| Dimensions and Weight | | Voltages, Currents, Potentials | |
|--|----------------|--|----------------|
| Dimensions W × H × D (in millimeters) | 25 × 290 × 210 | Rated supply voltage of the electronics and sensor L+ | 24 VDC |
| Weight | Approx. 600 g | • Reverse polarity protection | Yes |
| Data for Specific Module | | Number of inputs that can be triggered simultaneously | 16 |
| Number of inputs | 16 | Isolation | |
| Length of cable | | • Between channels and backplane bus | Yes |
| • Unshielded input delay | | • Between channels and power supply of the electronics | No |
| – 0.1 ms | Max. 20 m | • Between the channels | Yes |
| – 0.5 ms | Max. 50 m | – In groups of | 2 |
| – 3 ms | Max. 600 m | Permitted potential difference | |
| • Shielded input delay | | • Between the different circuits | 75 VDC, 60 VAC |
| – 0.1 ms | Max. 30 m | Insulation tested with | |
| – 0.5 ms | Max. 70 m | • Channels against backplane bus and load voltage L+ | 500 VDC |
| – 3 ms | Max. 1000 m | • Channel groups between themselves | 500 VDC |
| | | Current consumption | |
| | | • From the backplane bus | Max. 130 mA |
| | | • From the power supply L+ | Max. 120 mA |
| | | Power dissipation of the module | Typ. 5 W |

| Status, Interrupts, Diagnostics | | Data for Selecting a Sensor | |
|--|---|--|----------------------|
| Status display | Green LED per channel | Input voltage | |
| Interrupts | | <ul style="list-style-type: none"> Rated value 24 VDC For signal "1" 11 V to 30 V For signal "0" -30 V to 5 V | |
| <ul style="list-style-type: none"> Hardware interrupt Diagnostic Interrupt | Parameters can be assigned | Input current | |
| Diagnostic functions | | <ul style="list-style-type: none"> At signal "1" 6 mA to 12 mA At signal "0" < 6 mA | |
| <ul style="list-style-type: none"> Monitoring of the power supply voltage of the electronics Load voltage monitor Group error display <ul style="list-style-type: none"> For internal fault For external fault Channel error display (F) Diagnostic information can be displayed | Yes Green LED per group Red LED (INTF) Red LED (EXTF) None Yes | Input characteristic curve | To IEC 61131; type 2 |
| Monitoring for | | Connection of two-wire BEROs | Possible |
| <ul style="list-style-type: none"> Wire break | I < 1 mA | <ul style="list-style-type: none"> Permitted bias current | Max. 3 mA |
| Substitute value can be applied | Yes | Time, Frequency | |
| Sensor Power Supply Outputs | | Internal preparation time for | |
| Number of outputs | 2 | <ul style="list-style-type: none"> Only hardware interrupt enable <ul style="list-style-type: none"> Input delay the same for both channel groups Max. 70 μs Input delay not the same for both channel groups Max. 120 μs Enable hardware and diagnostic interrupts Max. 5 ms | |
| Output voltage | | Input delay | |
| <ul style="list-style-type: none"> with load | Min. L+(-2.5 V) | <ul style="list-style-type: none"> Parameters can be assigned Yes Rated value 0.1/0.5/3 ms Input frequency (with a time delay of 0.1 ms) < 2 kHz | |
| Output current | | Both values go into cycle and response times. | |
| <ul style="list-style-type: none"> Rated value Permitted range | 120 mA 0 to 150 mA | Sensor Circuit | |
| Additional (redundant) supply | Possible | Resistance circuit of the sensor for wire break monitoring | 10 to 18 kΩ |
| Short-circuit protection | Yes, electronic | | |

4.9.1 Assigning Parameters to the SM 421; DI 16 × 24 VDC

Parameter Assignment

You will find a description of the general procedure for assigning parameters to digital modules in Section 5.7.

Parameters of the SM 421; DI 16 × 24 VDC

You will find an overview of the parameters you can set and their default settings for the SM 421; DI 16 × 24 VDC in the table below.

Table 4-10 Parameters of the SM 421; DI 16 × 24 VDC

| Parameter | Value Range | Default ²⁾ | Parameter Type | Scope |
|--------------------------------------|--|-----------------------|----------------|---------------|
| Enable | | | | |
| • Diagnostic interrupt ¹⁾ | Yes/no | No | Dynamic | Module |
| • Hardware interrupt ¹⁾ | Yes/no | No | Dynamic | Module |
| • Destination CPU for interrupt | 1 to 4 | – | Static | Module |
| Diagnostics | | | | |
| • Wire break | Yes/no | No | Static | Channel |
| • No load voltage L+/sensor supply | Yes/no | No | Static | Channel group |
| Trigger for hardware interrupt | | | | |
| • Rising edge | Yes/no | – | Dynamic | Channel |
| • Falling edge | Yes/no | – | Dynamic | Channel |
| Input delay | 3 ms (DC) 0.1 ms (DC) 0.5 ms (DC/AC) | 3 (DC) | Static | Channel group |
| Reaction to Error | Substitute a Value (SV) Keep Last Value (KLV) | SV | Dynamic | Module |
| Enable substitute value "1" | Yes/no | No | Dynamic | Channel |

1) If you use the module in ER-1/ER-2, you must set this parameter to "No" because the interrupt lines are not available in ER-1/ER-2.

2) Only in the CC (central controller) is it possible to start up the digital modules with the default settings.

Assignment of the Encoder Supplies to Channel Groups

The two encoder supplies of the module are used to supply two channel groups: inputs 0 to 7 and inputs 8 to 15. In these two channel groups, you parameterize the diagnostics for the encoder supply, too.

Ensuring a Wire Break Check Is Carried Out

To ensure that a wire break check is carried out, you require an external sensor circuit using a resistor of 10 to 18 k Ω . The resistor should be connected parallel to the contact and should be arranged as closely as possible to the sensor.

This additional resistor is not required in the following cases:

- If two-wire BEROs are used
- If you don't parameterize the "Wire Break" diagnosis

Setting the Input Delay for Channel Groups

You can only set the input delay for each group of channels. In other words, the setting for channel 0 applies to inputs 0 to 7 and the setting for channel 8 applies to inputs 8 to 15.

Note

The parameters that are entered for the remaining channels (1 to 7 and 9 to 15) must be equal to the value 0 or 8, otherwise those channels will be reported as being incorrectly parameterized.

Any hardware interrupts that have occurred in the meantime will be reported after acknowledgement.

Optimum Signal Propagation Delay

You can achieve the fastest signal propagation delay with the following settings:

- Both channel groups are parameterized with an input delay of 0.1 ms
- All the diagnoses (load voltage error, wire break) are deactivated
- Diagnostic interrupt is not enabled

4.9.2 Behavior of the SM 421; DI 16 × 24 VDC

Effect of Operating Mode and Supply Voltage on the Input Values

The input values of the SM 421; DI 16 × 24 DC depend on the operating mode of the CPU and on the supply voltage of the module.

Table 4-11 How the Input Values Depend on the Operating Mode of the CPU and on the Supply Voltage L+ of the SM 421; DI 16 × 24 VDC

| CPU Operating Mode | | Power Supply L+ to Digital Module | Input Value of Digital Module |
|--------------------|------|-----------------------------------|-------------------------------|
| POWER ON | RUN | L+ exists | Process value |
| | | L+ missing | 0 signal * |
| | STOP | L+ exists | Process value |
| | | L+ missing | 0 signal* |
| POWER OFF | – | L+ exists | – |
| | | L+ missing | – |

* Depends on the parameter assignment (see Table 4–12)

Behavior upon Failure of the Supply Voltage

Failure of the supply voltage of the SM 421; DI 16 × 24 DC is always indicated by the EXTf LED on the module. Furthermore, this information is made available on the module (entry in diagnosis).

Triggering of the diagnostic interrupt depends on the parameter assignment (see Section 4.9.1).

Short-Circuit of Sensor Supply Vs

Irrespective of the parameter assignment, the corresponding Vs LED goes out if a short-circuit of the encoder supply Vs occurs.

Effect of Errors and Parameter Assignment on the Input Values

The input values of the SM 421; DI 16 × 24 DC are affected by certain errors and the parameter assignment of the module. The following table lists the effects on the input values.

You will find more diagnostic messages of the module in the Appendix entitled “Diagnostic Data of the Signal Modules”.

Table 4-12 How the Input Values Are Affected by Faults and by the Parameter Assignment of the SM 421; DI 16 × 24 VDC

| Diagnostic Message | “Diagnostics” Parameter | “Reaction to Error” Parameter | Input Value of Digital Module |
|---|-------------------------|-------------------------------|---|
| Module not parameterized | Cannot be disabled | Not relevant | 0 signal (all channels) |
| No front connector | | SV | Parameterized substitute value |
| | | KLV | Last read, valid value |
| Incorrect parameters (module/channel) | Cannot be disabled | Not relevant | 0 signal (module/all incorrectly parameterized channels) |
| STOP operating mode | Cannot be disabled | – | Process value (not updated) |
| Internal voltage failure | Cannot be disabled | SV | Parameterized substitute value |
| | | KLV | Last read, valid value |
| Hardware interrupt lost | Cannot be disabled | Not relevant | Current process value |
| Wire break (for each channel) | Deactivated | – | 0 signal |
| | Activated | SV | Parameterized substitute value |
| KLV | | Last read, valid value | |
| Sensor supply missing (also activated via “No Load Voltage L+”) | Deactivated | – | 0 signal |
| | Activated | SV | Parameterized substitute value |
| KLV | | Last read, valid value | |
| No load voltage L+ (for each channel group) | Deactivated | – | 0 signal, if the contact is connected via the sensor supply; process value for the external sensor supply |
| | | Activated | SV |
| KLV | Last read, valid value | | |

Behavior when the Input Delay Equals 0.1 ms and an Error Occurs

If you have parameterized the following:

- An input delay of 0.1 ms
- KLV or SV as the response to an error
- Substitute "1"

In the event of a fault on a channel that has a 1 signal, the following could occur before the last valid value or the substitute value "1" is output:

- An 0 signal may be briefly output
- If parameterized, a hardware interrupt may be generated

4.10 Digital Input Module SM 421; DI 16 × 24 VDC; (6ES7421-7BH01-0AB0)

Characteristics

The digital input module SM 421; DI 16 × 24 VDC has the following features:

- 16 inputs, isolated in 2 groups of 8
- 24 VDC rated input voltage
- Suitable for switches and two/three/four-wire proximity switches (BEROs, IEC 61131; type 2)
- 2 short-circuit-proof sensor supplies for 8 channels each
- External redundant power supply possible to supply sensors
- “Sensor supply (Vs) O.K.” status display
- Group error display for internal faults (INTF) and external faults (EXTF)
- Programmable diagnostics
- Programmable diagnostic interrupt
- Programmable hardware interrupt
- Programmable input delays
- Parameterizable substitute values in the input range

The status LEDs indicate the process status.

Note

The spare parts of this module is compatible with SM 421; DI 16 × DC 24 V; (6ES7 421-7BH00-0AB0).

To be able to use the new function “input delay 50 μs”, you require STEP 7 V 5.2.

Terminal Assignment and Block Diagram of the SM 421; DI 16 × 24 VDC

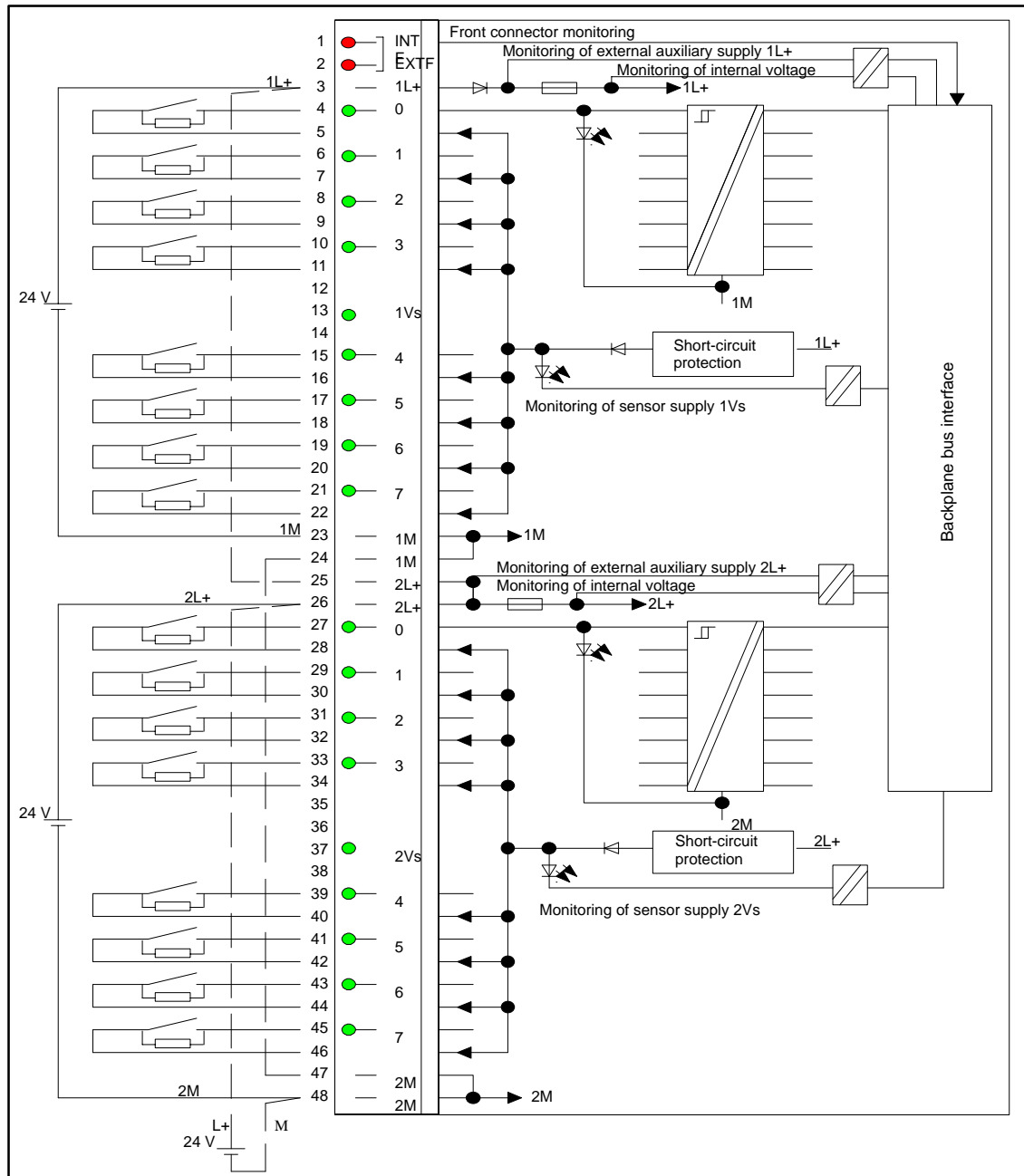

Figure 4-6 Terminal Assignment and Block Diagram of the SM 421; DI 16 × 24 VDC

Terminal Assignment Diagram for Redundant Supply of Sensors

The figure below shows how sensors can additionally be supplied by means of V_s with a redundant voltage source – for example, via another module).

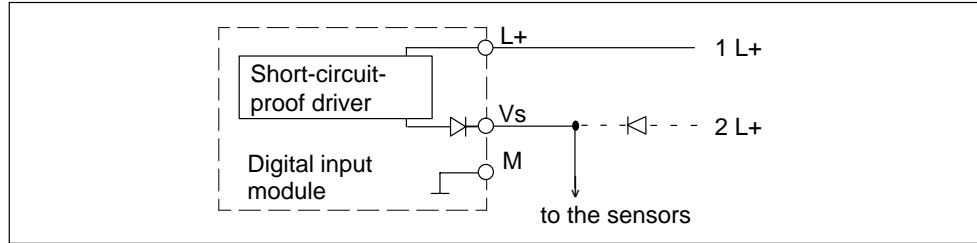

Figure 4-7 Terminal Assignment Diagram for the Redundant Supply of Sensors of the SM 421; DI 16 × 24 VDC

Technical Specifications of the SM 421; DI 16 × 24 VDC

| Dimensions and Weight | | Voltages, Currents, Potentials | |
|---------------------------------------|----------------|--|----------------|
| Dimensions W × H × D (in millimeters) | 25 × 290 × 210 | Rated supply voltage of the electronics and sensor L+ | 24 VDC |
| Weight | Approx. 600 g | • Reverse polarity protection | Yes |
| Data for Specific Module | | Number of inputs that can be triggered simultaneously | 16 |
| Number of inputs | 16 | Isolation | |
| Length of cable | | • Between channels and backplane bus | Yes |
| • Unshielded input delay | | • Between channels and power supply of the electronics | No |
| – 0.1 ms | Max. 20 m | • Between the channels | Yes |
| – 0.5 ms | Max. 50 m | – In groups of | 2 |
| – 3 ms | Max. 600 m | Permitted potential difference | |
| • Shielded input delay | | • Between the different circuits | 75 VDC, 60 VAC |
| – 0.1 ms | Max. 30 m | Insulation tested with | |
| – 0.5 ms | Max. 70 m | • Channels against backplane bus and load voltage L+ | 500 VDC |
| – 3 ms | Max. 1000 m | • Channel groups between themselves | 500 VDC |
| | | Current consumption | |
| | | • From the backplane bus | Max. 130 mA |
| | | • From the power supply L+ | Max. 120 mA |
| | | Power dissipation of the module | Typ. 5 W |

| Status, Interrupts, Diagnostics | | Time, Frequency | |
|---|----------------------------|---|--------------|
| Status display | Green LED per channel | Internal preparation time ¹⁾ for | |
| Interrupts | | • only status recognition | |
| • Hardware interrupt | Parameters can be assigned | – Input delay of the channel groups 0.05 ms/0.05 ms | max. 50 µs |
| • Diagnostic Interrupt | Parameters can be assigned | – Input delay of the channel groups 0.05 ms/0.1 ms or 0.1 ms/0.1 ms | max. 70 µs |
| Diagnostic functions | | – Input delay of the channel groups ≥ 0.5 ms | max. 180 µs |
| • Monitoring of the power supply voltage of the electronics | Yes | • Status recognition and enable process interrupt | max. 60 µs |
| • Load voltage monitor | Green LED per group | – Input delay of the channel groups 0.05 ms/0.05 ms ²⁾ | |
| • Group error display | | – Input delay for the channel groups 0.05 ms/0.1 ms or 0.1 ms/0.1 ms | max. 80 µs |
| – For internal fault | Red LED (INTF) | – Input delay of the channel groups ≥ 0.5 ms | max. 190 µs |
| – For external fault | Red LED (EXTF) | | |
| • Channel error display (F) | None | | |
| • Diagnostic information can be displayed | Yes | | |
| Monitoring for | | | |
| • Wire break | I < 1 mA | | |
| Substitute value can be applied | Yes | | |
| Sensor Power Supply Outputs | | Internal preparation time for diagnostics/diagnostic interrupt | max. 5 ms |
| Number of outputs | 2 | Input delay | |
| Output voltage | | • Parameters can be assigned | Yes |
| • with load | Min. L+(–2.5 V) | • Rated value | 0.1/0.5/3 ms |
| Output current | | • Input frequency (with a time delay of 0.1 ms) | < 2 kHz |
| • Rated value | 120 mA | | |
| • Permitted range | 0 to 150 mA | | |
| Additional (redundant) supply | Possible | | |
| Short-circuit protection | Yes, electronic | | |
| Data for Selecting a Sensor | | Sensor Circuit | |
| Input voltage | | Resistance circuit of the sensor for wire break monitoring | 10 to 18 kΩ |
| • Rated value | 24 VDC | | |
| • For signal "1" | 11 V to 30 V | | |
| • For signal "0" | -30 V to 5 V | | |
| Input current | | | |
| • At signal "1" | 6 mA to 12 mA | | |
| • At signal "0" | < 6 mA | | |
| Input characteristic curve | To IEC 61131; type 2 | | |
| Connection of two-wire BEROs | Possible | | |
| • Permitted bias current | Max. 3 mA | | |

¹⁾ The filter times are added to the overall runtime of the selected input delay.

²⁾ Substitute functionality; diagnostics and diagnostic interrupt are not to be selected.

4.10.1 Assigning Parameters to the SM 421; DI 16 × 24 VDC

Parameter Assignment

You will find a description of the general procedure for assigning parameters to digital modules in Section 5.7.

Parameters of the SM 421; DI 16 × 24 VDC

You will find an overview of the parameters you can set and their default settings for the SM 421; DI 16 × 24 VDC in the table below.

Table 4-13 Parameters of the SM 421; DI 16 × 24 VDC

| Parameter | Value Range | Default ²⁾ | Parameter Type | Scope |
|--------------------------------------|--|-----------------------|----------------|---------------|
| Enable | | | | |
| • Diagnostic interrupt ¹⁾ | Yes/no | No | Dynamic | Module |
| • Hardware interrupt ¹⁾ | Yes/no | No | | |
| • Destination CPU for interrupt | 1 to 4 | – | Static | Module |
| Diagnostics | | | | |
| • Wire break | Yes/no | No | Static | Channel |
| • No load voltage L+/sensor supply | Yes/no | No | | Channel group |
| Trigger for hardware interrupt | | | | |
| • Rising edge | Yes/no | – | Dynamic | Channel |
| • Falling edge | Yes/no | | | |
| Input delay | 3 ms (DC) 0.1 ms (DC) 0.5 ms (DC/AC) | 3 | Static | Channel group |
| Reaction to Error | Substitute a Value (SV) Keep Last Value (KLV) | SV | Dynamic | Module |
| Enable substitute value "1" | Yes/no | No | Dynamic | Channel |

¹⁾ If you use the module in ER-1/ER-2, you must set this parameter to "No" because the interrupt lines are not available in ER-1/ER-2.

²⁾ Only in the CC (central controller) is it possible to start up the digital modules with the default settings.

Assignment of the Encoder Supplies to Channel Groups

The two encoder supplies of the module are used to supply two channel groups: inputs 0 to 7 and inputs 8 to 15. In these two channel groups, you parameterize the diagnostics for the encoder supply, too.

Ensuring a Wire Break Check Is Carried Out

To ensure that a wire break check is carried out, you require an external sensor circuit using a resistor of 10 to 18 k Ω . The resistor should be connected parallel to the contact and should be arranged as closely as possible to the sensor.

This additional resistor is not required in the following cases:

- If two-wire BEROs are used
- If you don't parameterize the "Wire Break" diagnosis

Setting the Input Delay for Channel Groups

You can only set the input delay for each group of channels. In other words, the setting for channel 0 applies to inputs 0 to 7 and the setting for channel 8 applies to inputs 8 to 15.

Note

The parameters that are entered for the remaining channels (1 to 7 and 9 to 15) must be equal to the value 0 or 8, otherwise those channels will be reported as being incorrectly parameterized.

Any hardware interrupts that have occurred in the meantime will be reported after acknowledgement.

Optimum Signal Propagation Delay

You can achieve the fastest signal propagation delay with the following settings:

- Both channel groups are parameterized with an input delay of 0.1 ms
- All the diagnoses (load voltage error, wire break) are deactivated
- Diagnostic interrupt is not enabled

4.10.2 Behavior of the SM 421; DI 16 × 24 VDC

Effect of Operating Mode and Supply Voltage on the Input Values

The input values of the SM 421; DI 16 × 24 DC depend on the operating mode of the CPU and on the supply voltage of the module.

Table 4-14 How the Input Values Depend on the Operating Mode of the CPU and on the Supply Voltage L+ of the SM 421; DI 16 × 24 VDC

| CPU Operating Mode | | Power Supply L+ to Digital Module | Input Value of Digital Module |
|--------------------|------|-----------------------------------|-------------------------------|
| POWER ON | RUN | L+ exists | Process value |
| | | L+ missing | 0 signal * |
| | STOP | L+ exists | Process value |
| | | L+ missing | 0 signal* |
| POWER OFF | - | L+ exists | - |
| | | L+ missing | - |

* Depends on the parameter assignment (see Table 4-13)

Behavior upon Failure of the Supply Voltage

Failure of the supply voltage of the SM 421; DI 16 × 24 DC is always indicated by the EXTf LED on the module. Furthermore, this information is made available on the module (entry in diagnosis).

Triggering of the diagnostic interrupt depends on the parameter assignment (see Section 4.9.1).

Short-Circuit of Sensor Supply Vs

Irrespective of the parameter assignment, the corresponding Vs LED goes out if a short-circuit of the encoder supply Vs occurs.

Effect of Errors and Parameter Assignment on the Input Values

The input values of the SM 421; DI 16 × 24 DC are affected by certain errors and the parameter assignment of the module. The following table lists the effects on the input values.

You will find more diagnostic messages of the module in the Appendix entitled “Diagnostic Data of the Signal Modules”.

Table 4-15 How the Input Values Are Affected by Faults and by the Parameter Assignment of the SM 421; DI 16 × 24 VDC

| Diagnostic Message | “Diagnostics” Parameter | “Reaction to Error” Parameter | Input Value of Digital Module |
|---|-------------------------|-------------------------------|---|
| Module not parameterized | Cannot be disabled | Not relevant | 0 signal (all channels) |
| No front connector | | SV | Parameterized substitute value |
| | | KLV | Last read, valid value |
| Incorrect parameters (module/channel) | Cannot be disabled | Not relevant | 0 signal (module/all incorrectly parameterized channels) |
| STOP operating mode | Cannot be disabled | – | Process value (not updated) |
| Internal voltage failure | Cannot be disabled | SV | Parameterized substitute value |
| | | KLV | Last read, valid value |
| Hardware interrupt lost | Cannot be disabled | Not relevant | Current process value |
| Wire break (for each channel) | Deactivated | – | 0 signal |
| | Activated | SV | Parameterized substitute value |
| | | KLV | Last read, valid value |
| Sensor supply missing (also activated via “No Load Voltage L+”) | Deactivated | – | 0 signal |
| | Activated | SV | Parameterized substitute value |
| | | KLV | Last read, valid value |
| No load voltage L+ (for each channel group) | Deactivated | – | 0 signal, if the contact is connected via the sensor supply; process value for the external sensor supply |
| | | SV | Parameterized substitute value |
| | | KLV | Last read, valid value |

Behavior when the Input Delay Equals 0.1 ms and an Error Occurs

If you have parameterized the following:

- An input delay of 0.1 ms or 0.05 ms
- KLV or SV as the response to an error
- Substitute "1"

In the event of a fault on a channel that has a 1 signal, the following could occur before the last valid value or the substitute value "1" is output:

- An 0 signal may be briefly output
- If parameterized, a hardware interrupt may be generated

4.11 Digital Input Module SM 421; DI 16 × 120 VAC; (6ES7421-5EH00-0AA0)

Characteristics

The SM 421; DI 16 × 120 VAC has the following features:

- 16 inputs, isolated
- 120 VAC rated input voltage
- Suitable for switches and two-wire proximity switches (BEROs, IEC 61131; type 2)

Terminal Assignment Diagram of the SM 421; DI 16 × 120 VAC

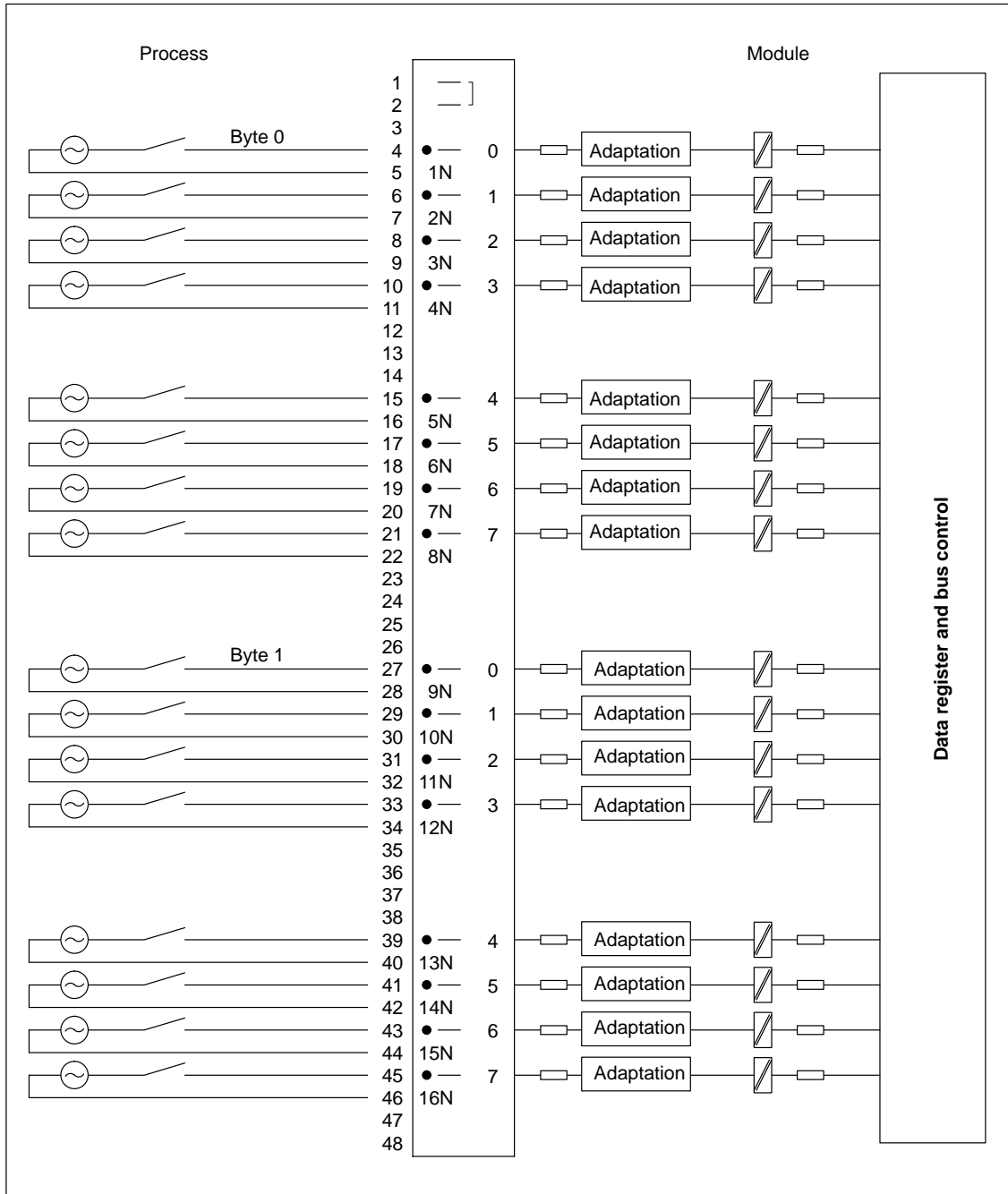

Figure 4-8 Terminal Assignment Diagram of the SM 421; DI 16 × 120 VDC

Technical Specifications of the SM 421; DI 16 × 120 VAC

| Dimensions and Weight | | Sensor Selection Data | |
|---|-----------------------|--|----------------------|
| Dimensions W × H × D (in millimeters) | 25 × 290 × 210 | Input voltage | |
| Weight | Approx. 650 g | <ul style="list-style-type: none"> • Rated value 120 V • For signal "1" 72 to 132 VAC • For signal "0" 0 to 20 V • Frequency range 47 to 63 Hz | |
| Data for Specific Module | | Input current | |
| Number of inputs | 16 | <ul style="list-style-type: none"> • At signal "1" 6 to 20 mA • At signal "0" 0 to 4 mA | |
| Length of cable | | Input delay | |
| <ul style="list-style-type: none"> • Unshielded 600 m • Shielded 1000 m | | <ul style="list-style-type: none"> • At "0" to "1" 2 to 15 ms • At "1" to "0" 5 to 25 ms | |
| Voltages, Currents, Potentials | | Input characteristic curve | To IEC 61131; type 2 |
| Number of inputs that can be triggered simultaneously | 16 | Connection of two-wire BEROs | Possible |
| Isolation | | <ul style="list-style-type: none"> • Permitted bias current Max. 4 A | |
| <ul style="list-style-type: none"> • Between channels and backplane bus Yes • Between the channels Yes – In groups of 1 | | | |
| Permitted potential difference | | | |
| <ul style="list-style-type: none"> • Between M_{internal} and the inputs 120 VAC • Between the inputs of the different groups 250 VAC | | | |
| Insulation tested with | 1500 VAC | | |
| Current consumption | | | |
| <ul style="list-style-type: none"> • From the backplane bus Max. 0.1 A | | | |
| Power dissipation of the module | Typ. 3.0 W | | |
| Status, Interrupts, Diagnostics | | | |
| Status display | Green LED per channel | | |
| Interrupts | None | | |
| Diagnostic functions | None | | |

4.12 Digital Input Module SM 421; DI 16 × 24/60 VUC; (6ES7 421-7DH00-0AB0)

Characteristics

The SM 421; DI 16 × 24/60 VUC is characterized by the following features:

- 16 inputs, individually isolated
- Rated input voltage 24 VUC to 60 VUC
- Suitable for switches and two-wire proximity switches (BEROs)
- Suitable as active high and active low input
- Group error display for internal faults (INTF) and external faults (EXTF)
- Programmable diagnostics
- Programmable diagnostic interrupt
- Programmable hardware interrupt
- Programmable input delays

The status LEDs indicate the process status.

Terminal Assignment and Block Diagram of the SM 421; DI 16 × 24/60 VUC

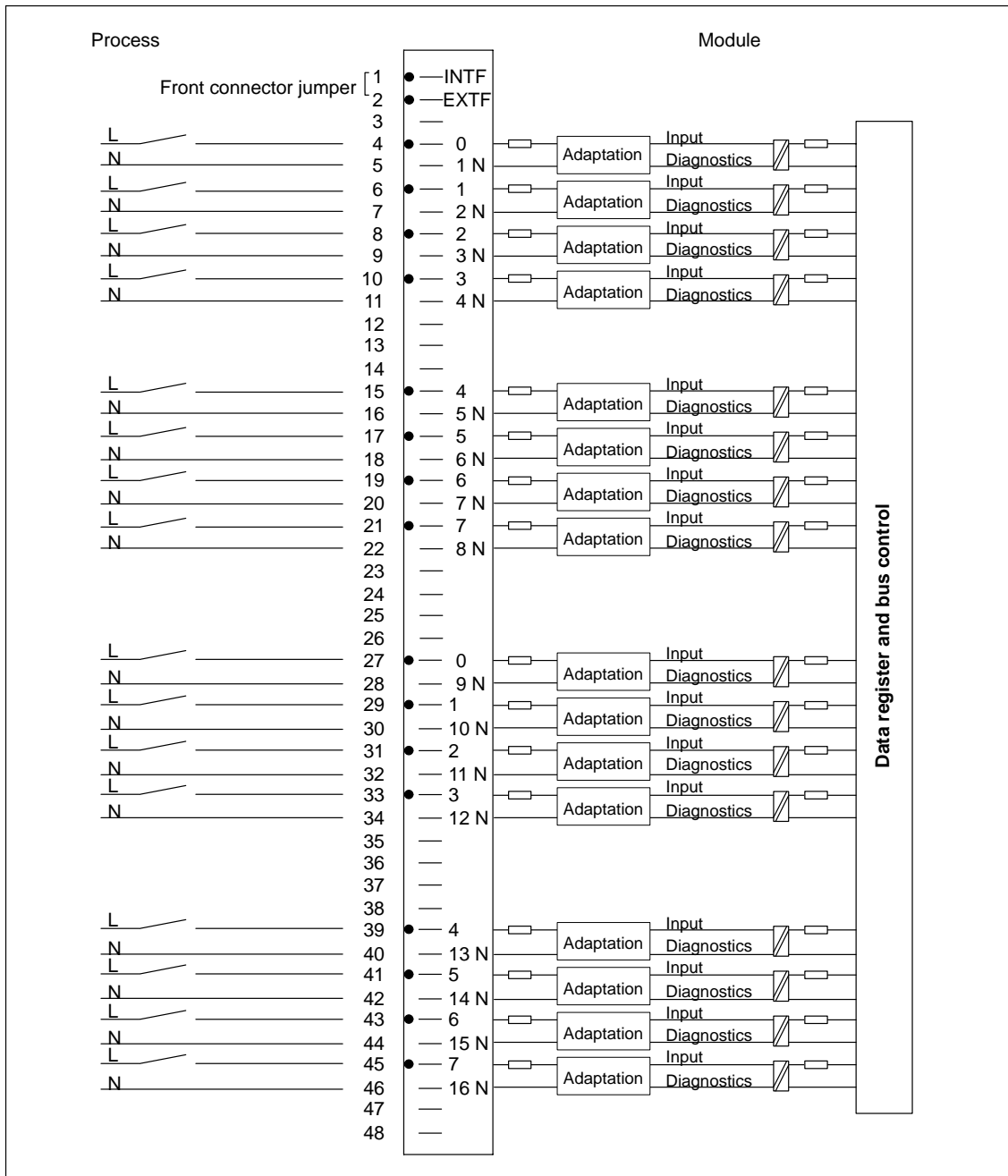

Figure 4-9 Terminal Assignment and Block Diagram of the SM 421; DI 16 × 24/60 VUC

Technical Specifications of the SM 421; DI 16 × 24/60 VUC

| Programming package | | | |
|---|----------------------------|--|--|
| Associated programming package | As of STEP 7 V 2.0 | • Channel error display (F) | None |
| Dimensions and Weight | | • Diagnostic information can be displayed | Possible |
| Dimensions W × H × D (in millimeters) | 25 × 290 × 210 | Monitoring for | |
| Weight | Approx. 600 g | • Wire break | I > 0.7 mA |
| Data for Specific Module | | Substitute value can be applied | No |
| Number of inputs | 16 | Sensor Selection Data | |
| Length of cable | | Input voltage | |
| • Unshielded input delay | | • Rated value | 24 VUC to 60 VUC |
| – 0.5 ms | Max. 100 m | • For signal "1" | 15 to 72 VDC -15 VDC to -72 VDC 15 to 60 VAC |
| – 3 ms | Max. 600 m | • For signal "0" | -6 VDC to +6 VDC 0 VAC to 5 VAC |
| – 10 / 20 ms | Max. 600 m | Frequency range | 47 DC/AC to 63 Hz |
| • Shielded line length | 1000 m | Input current | |
| Voltages, Currents, Potentials | | • At signal "1" | Typ. 4 mA to 10 mA |
| Number of inputs that can be triggered simultaneously | 16 | Input characteristic curve | Similar to IEC 61131 ¹⁾ |
| Isolation | | Connection of two-wire BEROs | Possible |
| • Between channels and backplane bus | Yes | • Permitted bias current | Max. 0.5 mA to 2 mA ²⁾ |
| • Between the channels | Yes | Time, Frequency | |
| – In groups of | 1 | Internal preparation time for | |
| Permitted potential difference | | • Only hardware interrupt enable | Max. 450 μs |
| • Between the different circuits | 75 VDC, 60 VAC | • Enable hardware and diagnostic interrupts | Max. 2 ms |
| Insulation tested with | | Input delay | |
| • Channels against backplane bus and load voltage L+ | 1500 VAC | • Parameters can be assigned | Yes |
| • Channels among one another | 1500 VAC | • Rated value | 0.5/3/10/20 ms |
| Current consumption | | Values go into cycle and response times. | |
| • From the backplane bus | Max. 150 mA | Sensor Circuit | |
| Power dissipation of the module | Typ. 8 W | Resistance circuit of the sensor for wire break monitoring | |
| Status, Interrupts, Diagnostics | | • Rated voltage 24 V (15 V to 35 V) | 18 kΩ |
| Status display | Green LED per channel | • Rated voltage 48 V (30 V to 60 V) | 39 kΩ |
| Interrupts | | • Rated voltage 60 V (50 V to 72V) | 56 kΩ |
| • Hardware interrupt | Parameters can be assigned | | |
| • Diagnostic Interrupt | Parameters can be assigned | | |
| Diagnostic functions | Parameters can be assigned | | |
| • Group error display | | | |
| – For internal fault | Red LED (INTF) | | |
| – For external fault | Red LED (EXTF) | | |

1) IEC 61131 does not specify any data for UC modules. The values have been adapted as much as possible to IEC 61131.
 2) Minimum closed-circuit current is required for wire break monitoring.

4.12.1 Assigning Parameters to the SM 421; DI 16 × 24/60 VUC

Parameter Assignment

You will find a description of the general procedure for assigning parameters to digital modules in Section 4.3.

Parameters of the SM 421; DI 16 × 24/60 VUC

The following table contains an overview of the parameters you can set and their default settings for the SM 421; DI 16 × 24/60 VUC.

Table 4-16 Parameters of the SM 421; DI 16 × 24/60 VUC

| Parameter | Value Range | Default ²⁾ | Parameter Type | Scope |
|--------------------------------------|---|-----------------------|----------------|---------------|
| Enable | | | | |
| • Diagnostic interrupt ¹⁾ | Yes/no | No | Dynamic | Module |
| • Hardware interrupt ¹⁾ | Yes/no | No | | |
| • Destination CPU for interrupt | 1 to 4 | – | Static | Module |
| Diagnostics | | | | |
| • Wire break | Yes/no | No | Static | Channel |
| Trigger for hardware interrupt | | | | |
| • Rising (positive) edge | Yes/no | – | Dynamic | Channel |
| • Falling (negative) edge | Yes/no | | | |
| Input delay ³⁾ | 0.5 ms (DC) 3 ms (DC) 20 ms (DC/AC) | 3 (DC) | Static | Channel group |

1) If you use the module in ER-1/ER-2, you must set this parameter to “No” because the interrupt lines are not available in ER-1/ER-2.

2) Only in the CC (central controller) is it possible to start up the digital modules with the default settings.

3) If you assign 0.5 ms, then you should not parameterize a diagnosis because the internal processing time for diagnostic functions can be > 0.5 ms.

Ensuring a Wire Break Check Is Carried Out

To ensure that a wire break check is carried out, you require an external sensor circuit using a resistor of 18 to 56 kΩ. The resistor should be connected parallel to the contact and should be arranged as closely as possible to the sensor.

This additional resistor is not required in the following cases:

- If two-wire BEROs are used
- If you don't parameterize the “Wire Break” diagnosis

Setting the Input Delay for Channel Groups

You can only set the input delay for each group of channels. In other words, the setting for channel 0 applies to inputs 0 to 7 and the setting for channel 8 applies to inputs 8 to 15.

Note

The parameters that are entered for the remaining channels (1 to 7 and 9 to 15) must be equal to the value 0 or 8, otherwise those channels will be reported as being incorrectly parameterized.

Any hardware interrupts that have occurred in the meantime will be reported after acknowledgement.

Optimum Signal Propagation Delays

You can achieve the fastest signal propagation delay with the following settings:

- Both channel groups are parameterized with an input delay of 0.5 ms
- The Diagnostics parameter is disabled
- The Diagnostic Interrupt parameter is disabled

Circuit as for active high or active low input

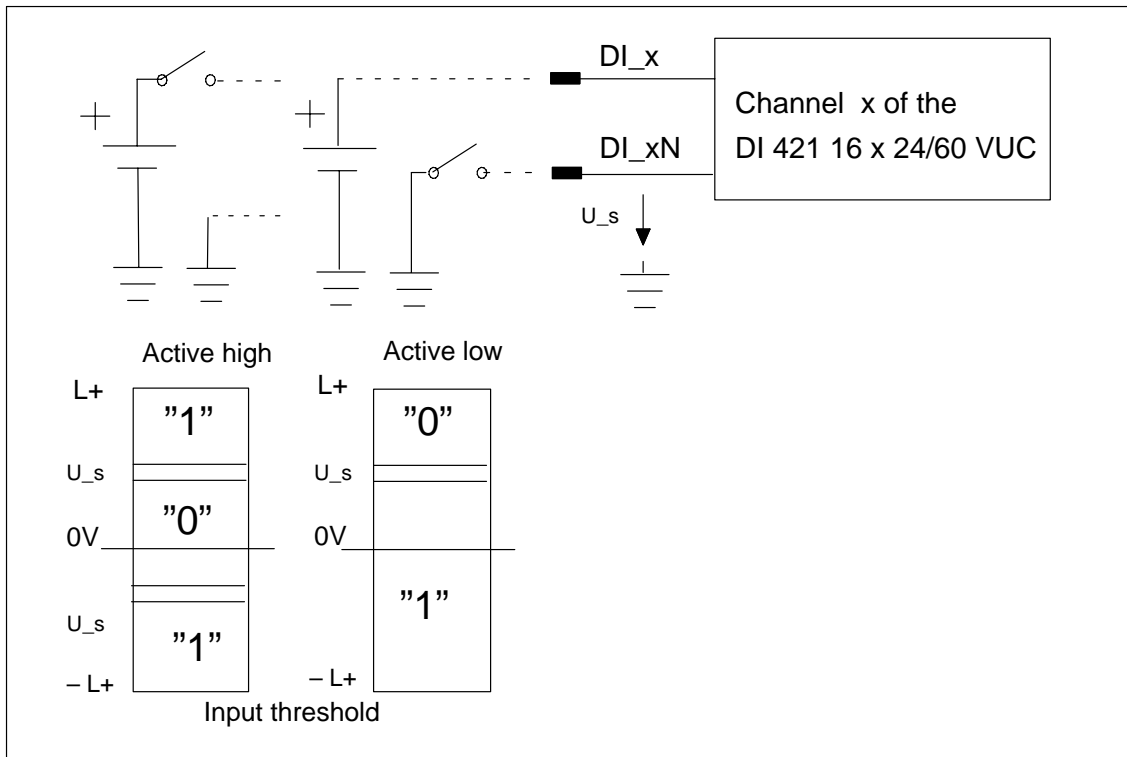

Figure 4-10 Circuit as for Active High or Active Low Input

4.13 Digital Input Module SM 421; DI 16 × 120/230 VUC; (6ES7 421-1FH00-0AA0)

Characteristics

The SM 421; DI 16 × 120/230 VUC is characterized by the following features:

- 16 inputs, isolated
- Rated input voltage 120/230 VAC/VDC
- Suitable for switches and two-wire proximity switches

Terminal Assignment and Block Diagram of the SM 421; DI 16 × 120/230 VUC

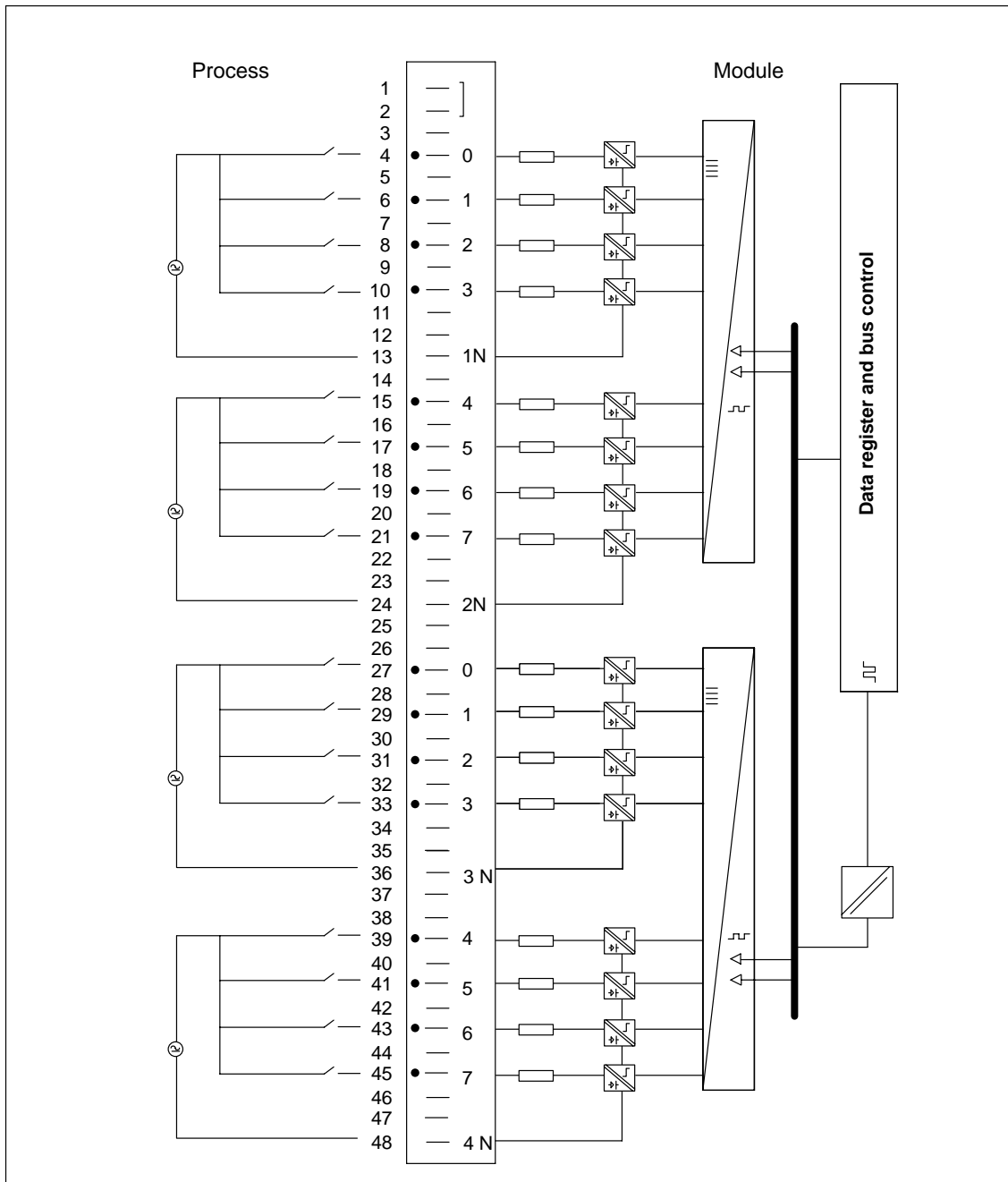

Figure 4-11 Terminal Assignment and Block Diagram of the SM 421; DI 16 × 120/230 VUC

Technical Specifications of the SM 421; DI 16 × 120/230 VUC

| Programming package | | Data for Selecting a Sensor | |
|---|--|------------------------------|--------------------------------|
| Associated programming package | As of STEP 7 V 2.0 | Input voltage | |
| Dimensions and Weight | | • Rated value | 120/230 VUC |
| Dimensions W × H × D (in millimeters) | 25 × 290 × 210 | • For signal "1" | 79 to 264 VAC 80 to 264 VDC |
| Weight | Approx. 650 g | • For signal "0" | 0 VUC to 40 VUC |
| Data for Specific Module | | • Frequency range | 47 to 63 Hz |
| Number of inputs | 16 | Input current | |
| Length of cable | | • At signal "1" | 2 mA to 5 mA |
| • Unshielded | 600 m | • At signal "0" | 0 to 1 mA |
| • Shielded | 1000 m | Input delay | |
| Voltages, Currents, Potentials | | • At "0" to "1" | 5 to 25 ms |
| Number of inputs that can be triggered simultaneously | 16 at 120 V 8 at 240 V 16 with fan subassembly | • At "1" to "0" | 5 to 25 ms |
| Isolation | | Input characteristic curve | To IEC 61131; type 1 |
| • Between channels and backplane bus | Yes | Connection of two-wire BEROs | Possible |
| • Between the channels | Yes | • Permitted bias current | Max. 1 mA |
| – In groups of | 4 | | |
| Permitted potential difference | | | |
| • Between M _{internal} and the inputs | 230 VAC | | |
| • Between the inputs of the different groups | 500 VAC | | |
| Insulation resistance | 4000 VAC | | |
| Current consumption | | | |
| • From the backplane bus | Max. 0.1 A | | |
| Power dissipation of the module | Typ. 3.5 W | | |
| Status, Interrupts, Diagnostics | | | |
| Status display | Green LED per channel | | |
| Interrupts | None | | |
| Diagnostic functions | None | | |

4.14 Digital Input Module SM 421; DI 16 × 120/230 VUC; (6ES7421-1FH20-0AA0)

Characteristics

The SM 421; DI 16 × 120/230 VUC is characterized by the following features:

- 16 inputs, isolated in groups of 4
- Rated input voltage 120/230 VUC
- Input characteristic curve to IEC 61131; type 2
- Suitable for switches and two-wire proximity switches (BEROs)

The status LEDs indicate the process status.

Terminal Assignment and Block Diagram of the SM 421; DI 16 × 120/230 VUC

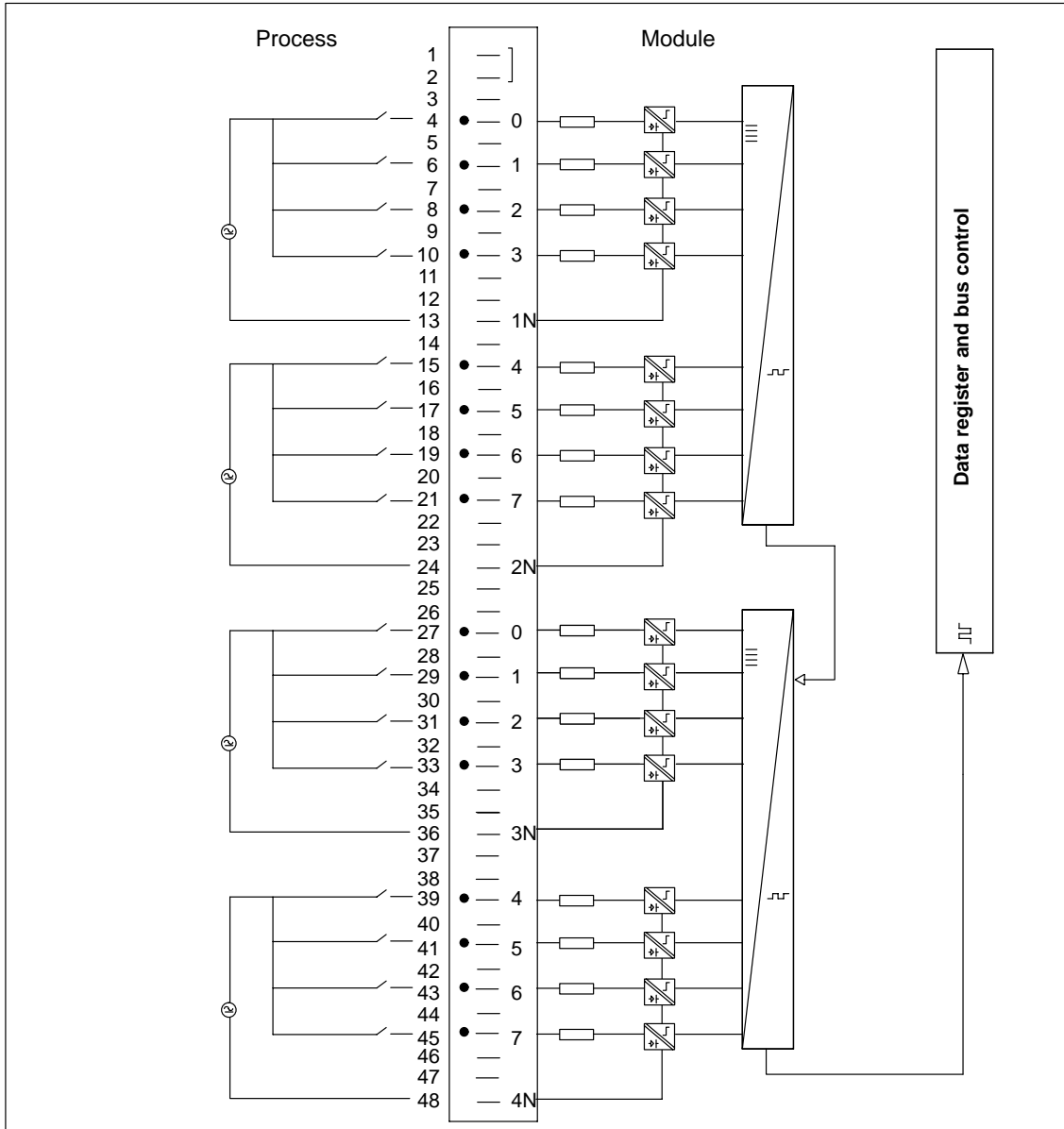

Figure 4-12 Terminal Assignment and Block Diagram of the SM 421; DI 16 × 120/230 VUC

Technical Specifications of the SM 421; DI 16 x 120/230 VUC

| Dimensions and Weight | | Data for Selecting a Sensor | |
|---|-----------------------|---|---|
| Dimensions W × H × D (in millimeters) | 25 × 290 × 210 | Input voltage | |
| Weight | Approx. 650 g | <ul style="list-style-type: none"> Rated value For signal "1" For signal "0" | 120/230 VUC 74 to 264 VAC 80 to 264 VDC -80 to -264 VDC 0 to 40 VAC -40 to +40 VDC |
| Data for Specific Module | | Frequency range | 47 to 63 Hz |
| Number of inputs | 16 | Input current | |
| Length of cable | | <ul style="list-style-type: none"> At signal "1" (120 V) At signal "1" (230 V) At signal "0" | Typ. 10 mA AC Typ. 1.8 mA DC Typ. 14 mA AC Typ. 2 mA DC 0 to 6 mA AC 0 to 2 mA DC |
| <ul style="list-style-type: none"> Unshielded Shielded | 600 m 1000 m | Input delay | |
| Voltages, Currents, Potentials | | <ul style="list-style-type: none"> At "0" to "1" At "1" to "0" | Max. 20 ms AC Max. 15 ms DC Max. 30 ms AC Max. 25 ms DC |
| Power rated voltage of the electronics L+ | None | Input characteristic curve | To IEC 61131; type 2 |
| Number of inputs that can be triggered simultaneously | 16 | Connection of two-wire BEROs | Possible |
| Isolation | | <ul style="list-style-type: none"> Permitted bias current | Max. 5 mA AC |
| <ul style="list-style-type: none"> Between channels and backplane bus Between the channels – In groups of | Yes Yes 4 | | |
| Permitted potential difference | | | |
| <ul style="list-style-type: none"> Between M_{internal} and the inputs Between the inputs of the different groups | 250 VAC 500 VAC | | |
| Insulation resistance | 4000 VAC | | |
| Current consumption | | | |
| <ul style="list-style-type: none"> From the backplane bus | Max. 80 mA | | |
| Power dissipation of the module | Typ. 12 W | | |
| Status, Interrupts, Diagnostics | | | |
| Status display | Green LED per channel | | |
| Interrupts | None | | |
| Diagnostic functions | None | | |
| Substitute value can be applied | No | | |

4.15 Digital Input Module SM 421; DI 32 × 120 VUC; (6ES7421-1EL00-0AA0)

Characteristics

The SM 421; DI 32 × 120 VUC is characterized by the following features:

- 32 inputs, isolated
- Rated input voltage 120 VAC/VDC
- Suitable for switches and two-wire proximity switches

Terminal Assignment and Block Diagram of the SM 421; DI 32 × 120 VUC

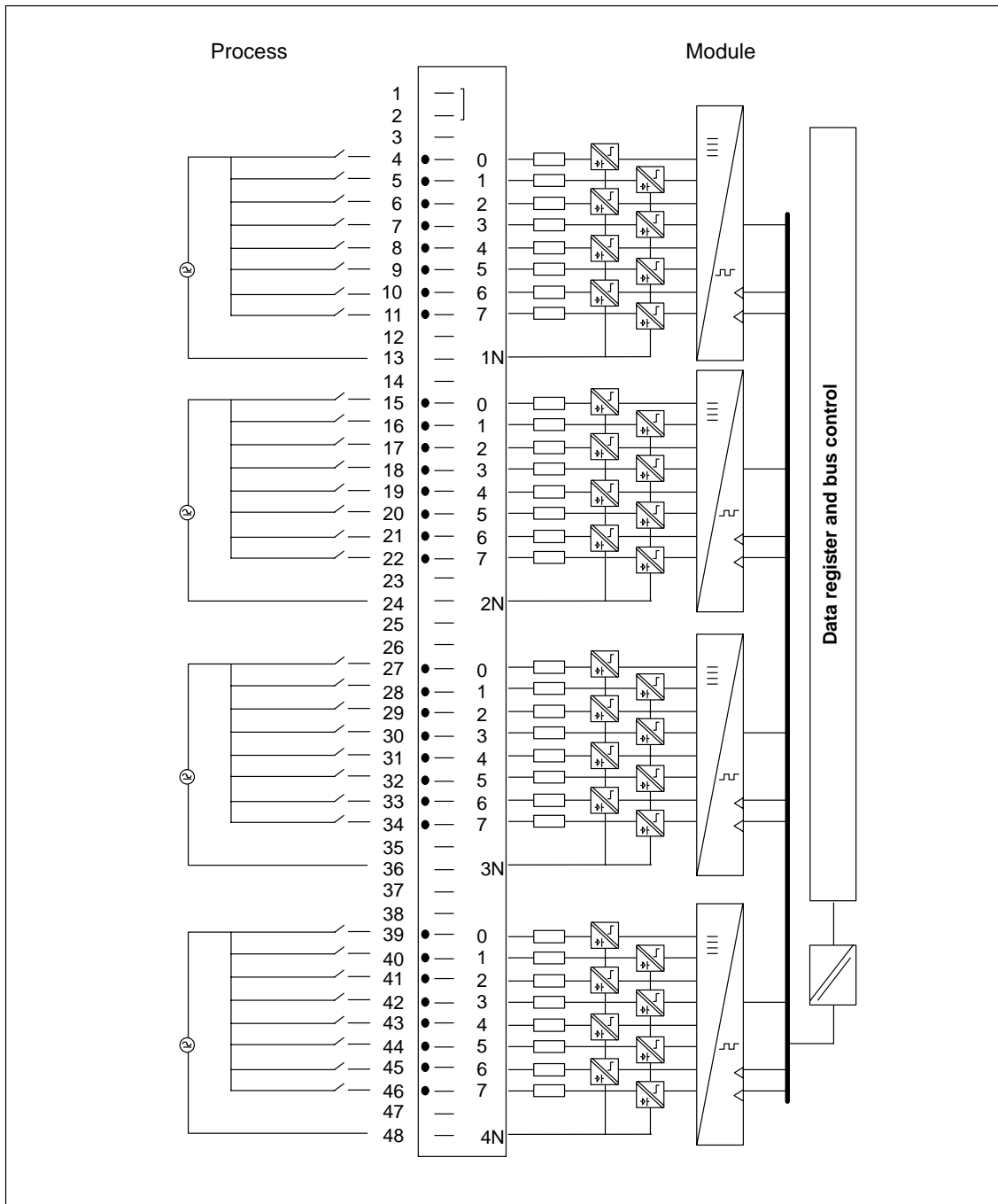

Figure 4-13 Terminal Assignment and Block Diagram of the SM 421; DI 32 × 120 VUC

Technical Specifications of the SM 421; DI 32 × 120 VUC

| Dimensions and Weight | | Data for Selecting a Sensor | |
|---|--------------------------------|------------------------------|----------------------|
| Dimensions W × H × D (mm) | 25 × 290 × 210 | Input voltage | |
| Weight | Approx. 600 g | • Rated value | 120 VUC |
| Data for Specific Module | | • For signal "1" | 79 to 132 VAC |
| Number of inputs | 32 | 80 VDC to 132 VDC | |
| Length of cable | | • For signal "0" | 0 to 20 V |
| • Unshielded | 600 m | • Frequency range | 47 to 63 Hz |
| • Shielded | 1000 m | Input current | |
| Voltages, Currents, Potentials | | • At signal "1" | 2 mA to 5 mA |
| Rated load voltage L+ | 79 to 132 VAC 80 to 132 VDC | • At signal "0" | 0 to 1 mA |
| • Reverse polarity protection | Yes | Input delay | |
| Number of inputs that can be triggered simultaneously | 32 | • At "0" to "1" | 5 to 25 ms |
| Isolation | | • At "1" to "0" | 5 to 25 ms |
| • Between channels and backplane bus | Yes | Input characteristic curve | To IEC 61131; type 1 |
| • Between the channels | Yes | Connection of two-wire BEROs | Possible |
| – In groups of | 8 | • Permitted bias current | Max.1 mA |
| Permitted potential difference | | | |
| • Between M _{internal} and the inputs | 120 VAC | | |
| • Between the inputs of the different groups | 250 VAC | | |
| Insulation tested with | 1500 VAC | | |
| Current consumption | | | |
| • From the backplane bus | Max. 0.2 A | | |
| Power dissipation of the module | Typ. 6.5 W | | |
| Status, Interrupts, Diagnostics | | | |
| Status display | Green LED per channel | | |
| Interrupts | None | | |
| Diagnostic functions | None | | |

4.16 Digital Output Module SM 422; DO 16 × 24 VDC/2 A; (6ES7422-1BH10-0AA0)

Characteristics

The digital output module SM 422; DO 16 × 24 VDC/2 A has the following features.

- 16 outputs, isolated in two groups of 8
- 2 A output current
- 24 VDC rated load voltage

The status LEDs also indicate the system status even when the front connector is not inserted.



Caution

To commission the module, the rated load voltage must be applied at least once to each group of 8 outputs (e.g. connection of 1L **and** 3L). If voltage is not applied to a group due, for example, to 1L and 2L failing, **all** the outputs switch off, even those in the second group. The status LED continues to function in the same way.

Terminal Assignment and Block Diagram of the SM 422; DO 16 × 24 VDC/2 A

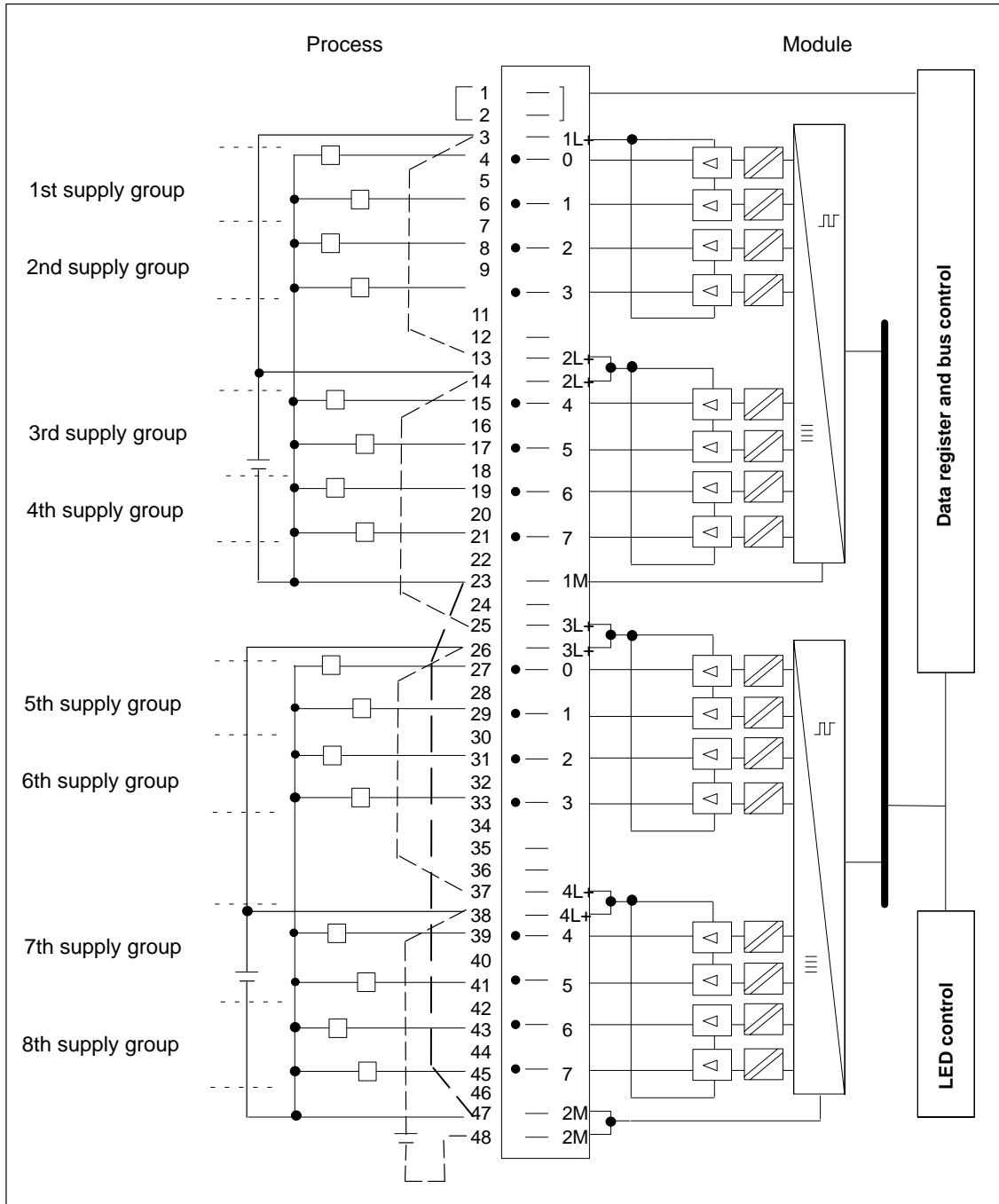

Figure 4-14 Terminal Assignment and Block Diagram of the SM 422; DO 16 × 24 VDC/2 A

Technical Specifications of the SM 422; DO 16 × 24 VDC/2 A

| Programming package | | Interrupts | None |
|---|-----------------------|--|---|
| Associated programming package | As of STEP 7 V 2.0 | Diagnostic functions | None |
| Dimensions and Weight | | Data for Selecting an Actuator | |
| Dimensions W × H × D (in millimeters) | 25 × 290 × 210 | Output voltage | |
| Weight | Approx. 600 g | • At signal "1" | Min. L+ (-0,5 V) |
| Data for Specific Module | | Output current | |
| Number of outputs | 16 | • At signal "1" | |
| Length of cable | | Rated value | 2A |
| • Unshielded | 600 m | Permitted range | 5 mA to 2.4 A |
| • Shielded | 1000 m | • At signal "0" (leakage current) | Max. 0.5 mA |
| Voltages, Currents, Potentials | | Output delay (for resistive load) | |
| Power rated voltage of the electronics L+ | 24 VDC | • From "0" to "1" | Max. 1 ms |
| Rated load voltage L+ | 24 VDC | • At "1" to "0" | Max. 1 ms |
| Aggregate current of the outputs (two outputs per supply group) | | Load resistor range | 12 Ω to 4 kΩ |
| Up to 40 °C | Max. 3 A | Lamp load | Max. 10 W |
| Up to 60 °C | Max. 2 A | Parallel connection of 2 outputs | |
| Isolation | | • For redundant triggering of a load | Possible (only outputs of the same group) |
| • Between channels and backplane bus | Yes | • To increase performance | Not possible |
| • Between the channels | Yes | Triggering a digital input | Possible |
| In groups of | 8 | Switch rate | |
| Permitted potential difference | | • For resistive load | 100 Hz |
| • Between the different circuits | 75 VDC / 60 VAC | • For inductive load to IEC 947-51, DC 13 | 0.2 Hz at 1 A 0.1 Hz at 2A |
| Insulation tested with | | • For lamp load | Max. 10 Hz |
| • Channels against backplane bus and load voltage L+ | 500 VDC | Limit (internal) of the inductive circuit interruption voltage up to | Max. -30 V |
| • Between the outputs of the different groups | 500 VDC | Short-circuit protection of output ¹ | Electronically cyclic ¹ |
| Current consumption | | • Threshold on | 2.8 to 6A |
| • From the backplane bus | Max. 160 mA | | |
| • Power supply and load voltage L+ (no load) | Max. 30 mA | | |
| Power dissipation of the module | Typ. 5 W | | |
| Status, Interrupts, Diagnostics | | | |
| Status display | Green LED per channel | | |

1) A supply group always consists of two adjacent channels starting with channel 0. Channels 0 and 1, 2 and 3 and so on up to 14 and 15 therefore form one supply group.

2) Following a short circuit, reclosing under a full load is not guaranteed. To prevent this, you can do one of the following things:

- Change the signal at the output
- Interrupt the load voltage of the module, or
- Briefly disconnect the load from the output

4.17 Digital Output Module SM 422; DO 16 × 24 VDC/2 A; (6ES7422-1BH11-0AA0)

Characteristics

The digital output module SM 422; DO 16 × 24 VDC/2 A has the following features.

- 16 outputs, isolated in two groups of 8
- 2 A output current
- 24 VDC rated load voltage

The status LEDs also indicate the system status even when the front connector is not inserted.

A Note about Commissioning

The following technical feature applies to the digital output module SM 422; DO 16 × 24 VDC/2 A with the order number 6ES7 422-1BH11-0AA0 but not to the digital output module SM 422; DO 16 × 24 VDC/2 A with the order number 6ES7 422-1BH10-0AA0:

To commission the module, it is **no** longer necessary to apply load voltage (1L+ and 3L+, for example,) to each group of 8 outputs. The module is fully operative even if only one group is supplied with L+.

Note

It is no longer possible to switch off all the outputs by disconnecting a single L+ supply as might have been the case with the previous module (6ES7 422-1BH10-0AA0)L+.

Terminal Assignment and Block Diagram of the SM 422; DO 16 × 24 VDC/2 A

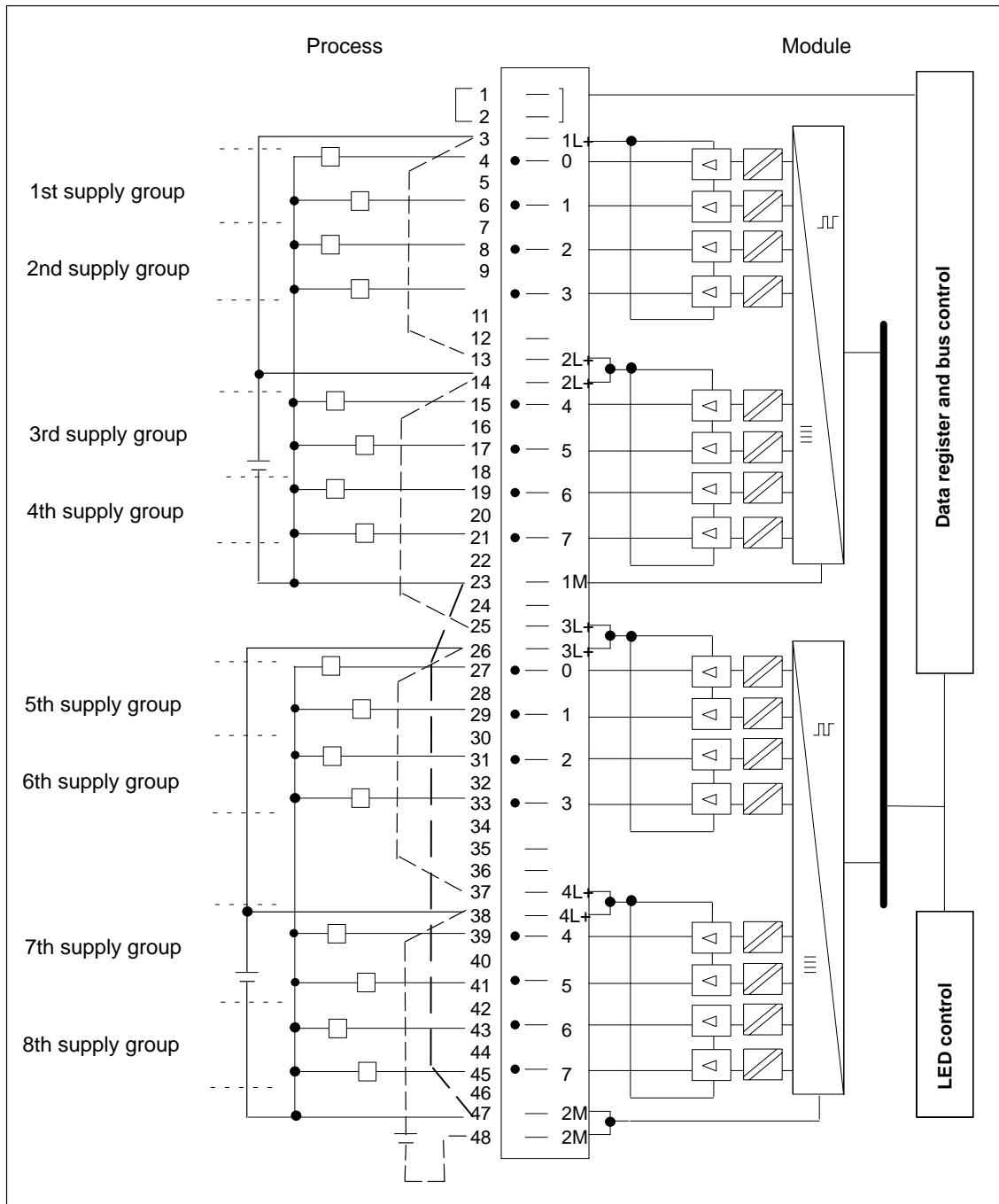

Figure 4-15 Terminal Assignment and Block Diagram of the SM 422; DO 16 × 24 VDC/2 A

Technical Specifications of the SM 422; DO 16 × 24 VDC/2 A

| Dimensions and Weight | | Data for Selecting an Actuator | |
|--|-----------------------|--|---|
| Dimensions W × H × D (in millimeters) | 25 × 290 × 210 | Output voltage | |
| Weight | Approx. 600 g | • At signal "1" | Min. L+ (-0,5 V) |
| Data for Specific Module | | Output current | |
| Number of outputs | 16 | • At signal "1" | |
| Length of cable | | Rated value | 2A |
| • Unshielded | 600 m | Permitted range | 5 mA to 2.4 A |
| • Shielded | 1000 m | • At signal "0" (leakage current) | Max. 0.5 mA |
| Voltages, Currents, Potentials | | Output delay (for resistive load) | |
| Power rated voltage of the electronics L+ | 24 VDC | • From "0" to "1" | Max. 1 ms |
| Rated load voltage L+ | 24 VDC | • At "1" to "0" | Max. 1 ms |
| Aggregate current of the outputs (two outputs per supply group ¹⁾) | | Load resistor range | 24 Ω to 4 kΩ |
| Up to 40 °C | Max. 3 A | Lamp load | Max. 10 W |
| Up to 60 °C | Max. 2 A | Parallel connection of 2 outputs | |
| Isolation | | • For redundant triggering of a load | Possible (only outputs of the same group) |
| • Between channels and backplane bus | Yes | • To increase performance | Not possible |
| • Between the channels | Yes | Triggering a digital input | Possible |
| In groups of | 8 | Switch rate | |
| Permitted potential difference | | • For resistive load | 100 Hz |
| • Between the different circuits | 75 VDC / 60 VAC | • For inductive load to IEC 947-51, DC 13 | 0.2 Hz at 1 A 0.1 Hz at 2A |
| Insulation tested with | | • For lamp load | Max. 10 Hz |
| • Channels against backplane bus and load voltage L+ | 500 VDC | Limit (internal) of the inductive circuit interruption voltage up to | Max. -30 V |
| • Between the outputs of the different groups | 500 VDC | Short-circuit protection of output ¹ | Electronically cyclic ²⁾ |
| Current consumption | | • Threshold on | 2.8 A to 6 A |
| • From the backplane bus | Max. 160 mA | | |
| • Power supply and load voltage L+ (no load) | Max. 30 mA | | |
| Power dissipation of the module | Typ. 5 W | | |
| Status, Interrupts, Diagnostics | | | |
| Status display | Green LED per channel | | |
| Interrupts | None | | |
| Diagnostic functions | None | | |

1) A supply group always consists of two adjacent channels starting with channel 0. Channels 0 and 1, 2 and 3 and so on up to 14 and 15 therefore form one supply group.

2) Following a short circuit, reclosing under a full load is not guaranteed. To prevent this, you can do one of the following things:

- Change the signal at the output, or
- Interrupt the load voltage of the module
- Briefly disconnect the load from the output

4.18 Digital Output Module

SM 422; DO 16 × 20-125 VDC/1.5 A;

(6ES7422-5EH10-0AB0)

Characteristics

The SM 422; DO 16 × 20-125 VDC/1.5 A has the following features:

- 16 outputs, each channel is fused; reverse polarity protection and isolated in groups of 8
- 1.5 A output current
- Rated load voltage 20 to 125 VDC
- Group error display for internal faults (INTF) and external faults (EXTF)
- Programmable diagnostics
- Programmable diagnostic interrupt
- Programmable substitute value output

Terminal Assignment Diagram of the SM 422; DO 16 × 20-125 VDC/1.5 A

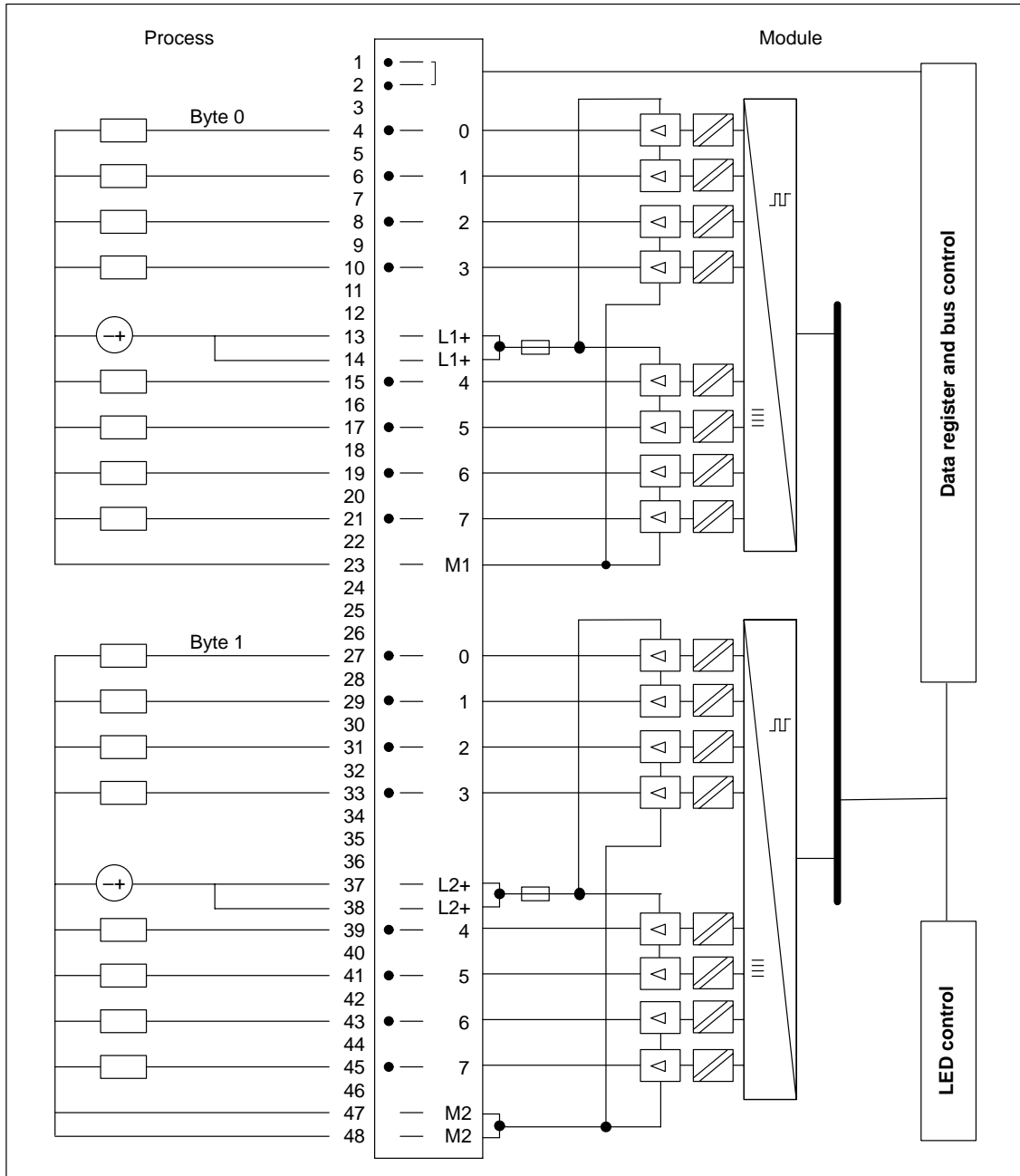

Figure 4-16 Terminal Assignment Diagram of the SM 422; DO 16 × 20-125 VDC/1.5 A

Technical Specifications of the SM 422; DO 16 × 20-125 VDC/1.5 A

| Dimensions and Weight | | Data for Selecting an Actuator | |
|--|-------------------------------|---|--|
| Dimensions W × H × D (in millimeters) | 25 × 290 × 210 | Output voltage | |
| Weight | Approx. 800 g | • At signal "1" | Min. L+ (-1,0 V) |
| Data for Specific Module | | Output current | |
| Number of outputs | 16 | • At signal "1" | |
| Length of cable | | Rated value | 1.5 A |
| • Unshielded | Max. 600 m | Permitted range | 10 mA to 1.5 A |
| • Shielded | Max. 1000 m | Permitted surge current | Max. 3 A (for 10 ms) |
| Voltages, Currents, Potentials | | • At signal "0" (leakage current) | Max. 0.5 mA |
| Rated load voltage L1 | 20 VDC to 138 VDC | Output delay (for resistive load) | |
| • Reverse polarity protection | Yes, with fuse | • From "0" to "1" | Max. 2 ms |
| Total current of the outputs ¹⁾ | | • At "1" to "0" | Max. 13 ms |
| Up to 40 °C | With fan subassembly | Parallel connection of 2 outputs | |
| Up to 60 °C | Max. 16 A 21 A | • For redundant triggering of a load | Possible (only outputs of the same group) |
| | Max. 8 A 14 A | • To increase performance | Possible (only outputs of the same group) |
| Isolation | | Triggering a digital input | Possible |
| • Between channels and backplane bus | Yes | Switch rate | |
| • Between the channels In groups of | Yes 8 | • For resistive load | Max. 10 Hz |
| Permitted potential difference | | • For inductive load to IEC 947-5-1, DC 13 | Max. 0.5 Hz |
| • Between the outputs of the different groups | 250 VAC | Short-circuit protection of output | Electronically protected ²⁾ |
| Insulation tested with | 1500 VAC | • Threshold on | Typ. 04 A to 5 A |
| Current consumption | | Replacement fuses | Fuse, 8 A/250 V, quick blow |
| • From the backplane bus | Max. 700 mA | | |
| • From load voltage L + (without load) | Max. 2 mA | | |
| Power dissipation of the module | Typ. 10 W | | |
| Status, Interrupts, Diagnostics | | | |
| Status display | Green LED per channel | | |
| Interrupts | | | |
| • Diagnostic Interrupt | Parameters can be assigned | | |
| Diagnostic functions | Parameters can be assigned | | |
| • Group error display | | | |
| – For internal fault | Red LED (INTF) | | |
| – For external fault | Red LED (EXTF) | | |
| • Diagnostic information readable | Yes | | |
| Substitute value can be applied | Yes, programmable | | |

1) To achieve maximum performance capability, distribute the high-current load between the two groups.

2) To reset a deactivated output, first set the output signal to 0 and then to 1. If output signal 1 is written to a deactivated output and the short circuit remains, additional interrupts are generated (provided the diagnostic interrupt parameter was set).

Note

If the power supply is switched on by means of a mechanical contact, a voltage pulse may occur at the outputs. The transient pulse lasts a maximum of 0.5 ms.

Changing Fuses



Warning

This can result in injury.

If you change a fuse without removing the front connector of the module, you could be injured by an electric shock.

Consequently, always remove the front connector before you change the fuse.

4.18.1 Assigning Parameters to the SM 422; DO 16 × 20-125 VDC/1.5 A

Parameter Assignment

You will find a description of the general procedure for assigning parameters to digital modules in Section 5.7.

Parameters of the SM 421; DO 16 × 20-125 VDC/1.5 A

You will find an overview of the parameters you can set and their default settings for the SM 422; DO 16 × 20-125 VDC/1.5 A in the following table.

Table 4-17 Parameters of the SM 422; DO 16 × 20-125 VDC/1.5 A

| Parameter | Value Range | Default ²⁾ | Parameter Type | Scope |
|---|--|-----------------------|----------------|---------------|
| Enable <ul style="list-style-type: none"> Diagnostic interrupt¹⁾ Destination CPU for interrupt | Yes/no | No | Dynamic | Module |
| | 1 to 4 | – | Static | Module |
| Reaction to CPU-STOP | Substitute a value (SV) Keep last value (KLV) | SV | Dynamic | Module |
| Diagnostics <ul style="list-style-type: none"> No load voltage L+ Short circuit to M | Yes/no | No | Static | Channel group |
| | Yes/no | No | | Channel |
| Enable substitute value "1" | Yes/no | No | Dynamic | Channel |

1) If you use the module in ER-1/ER-2, you must set this parameter to "No" because the interrupt lines are not available in ER-1/ER-2.

2) Only in the CC (central controller) is it possible to start up the digital modules with the default settings.

Assigning the "No Load Voltage L+" Diagnosis to Channel Groups

You can only set the "No Load Voltage L+" diagnosis separately for each channel group. In other words, the setting for channel 0 applies to inputs 0 to 7, and the setting for channel 8 applies to inputs 8 to 15.

4.19 Digital Output Module SM 422; DO 32 × 24 VDC/0.5 A; (6ES7422-1BL00-0AA0)

Characteristics

The SM 422; DO 32 x 24 VDC/0.5 A has the following features:

- 32 outputs, isolated in a group of 32
- Power is supplied to 8 channels in groups.
- A supply group always consists of eight adjacent channels starting with channel 0. Channels 0 to 7, 8 to 15, 16 to 23 and 24 to 32 therefore form one supply group
- Each of these supply groups can be switched off separately by isolating L+, however you have to take note of the common ground connection.
- 0.5 A output current
- 24 VDC rated load voltage

The status LEDs also indicate the system status even when the front connector is not inserted.

Terminal Assignment and Block Diagram of the SM 422; DO 32 × 24 VDC/0.5 A

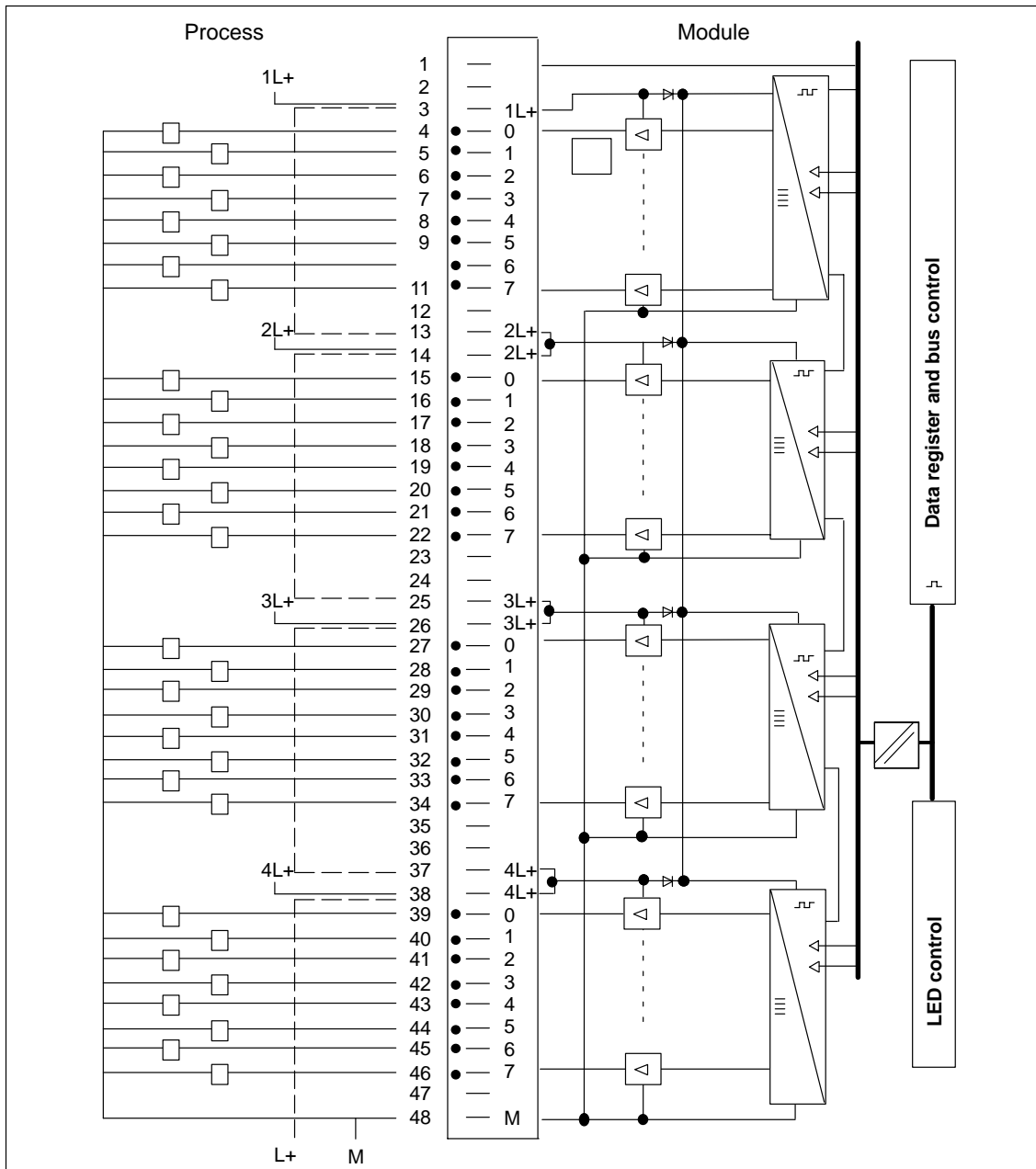

Figure 4-17 Terminal Assignment and Block Diagram of the SM 422; DO 32 × 24 VDC/0.5 A

Technical Specifications of the SM 422; DO 32 × 24 VDC/0.5 A

| Programming package | | Status, Interrupts, Diagnostics | |
|--|--------------------|--|--|
| Associated programming package | As of STEP 7 V 2.0 | Status display | Green LED per channel |
| Dimensions and Weight | | Interrupts | None |
| Dimensions W × H × D (in millimeters) | 25 × 290 × 210 | Diagnostic functions | None |
| Weight | Approx. 600 g | Data for Selecting an Actuator | |
| Data for Specific Module | | Output voltage | |
| Number of outputs | 32 | • At signal "1" | Min. L+ (-0,3 V) |
| Length of cable | | Output current | |
| • Unshielded | 600 m | • At signal "1" | |
| • Shielded | 1000 m | Rated value | 0.5 A |
| Voltages, Currents, Potentials | | Permitted range | 5 mA to 0.6 A |
| Power rated voltage of the electronics L+ | 24 VDC | • At signal "0" (leakage current) | Max. 0.3 mA |
| Rated load voltage L+ | 24 VDC | Output delay (for resistive load) | |
| Aggregate current of the outputs (per supply group of 8 outputs) | | • From "0" to "1" | Max. 1 ms |
| Up to 40 °C | Max. 4 A | • At "1" to "0" | Max. 1 ms |
| Up to 60 °C | Max. 2 A | Load resistor range | 48 Ω to 4 kΩ |
| Isolation | | Lamp load | Max. 5 W |
| • Between channels and backplane bus | Yes | Parallel connection of 2 outputs | |
| • Between the channels | No | • For redundant triggering of a load | Possible (only outputs of the same group) |
| Permitted potential difference | | • To increase performance | Possible (only outputs of the same group) |
| • Between the different circuits | 75 VDC / 60 VAC | Triggering a digital input | Possible |
| Insulation tested with | | Switch rate | |
| • Channels against backplane bus and load voltage L+ | 500 VDC | • For resistive load | Max. 100 Hz |
| • Load voltage L+ against backplane bus | 500 VDC | • For inductive load to IEC 947-5-1, DC 13 | Max. 2 Hz at 0.3 A Max. 0.5 Hz at 0.5 A |
| Current consumption | | • For lamp load | Max. 10 Hz |
| • From the backplane bus | Max. 200 mA | Limit (internal) of the inductive circuit interruption voltage up to | Typ. – 27 V |
| • Power supply and load voltage L+ (no load) | Max. 30 mA | Short-circuit protection of the output | Electronically cyclic |
| Power dissipation of the module | Typ. 4 W | • Threshold on | Typ. 0.7 A to 1.5 A |

¹⁾ A supply group always consists of eight adjacent channels starting with channel 0. Channels 0 to 7, 8 to 15, 16 to 23 and 24 to 32 therefore form one supply group.

4.20 Digital Output Module SM 422; DO 32 × 24 VDC/0.5 A; (6ES7422-7BL00-0AB0)

Characteristics

The digital output module SM 422; DO 32 × 24 VDC/0.5 A has the following features:

- 32 outputs, fused and isolated in groups of 8
- 0.5 A output current
- 24 VDC rated load voltage
- Group error display for internal faults (INTF) and external faults (EXTF)
- Programmable diagnostics
- Programmable diagnostic interrupt
- Programmable substitute value output

The status LEDs also indicate the system status even when the front connector is not inserted.

Terminal Assignment and Block Diagram of the SM 422; DO 32 × 24 VDC/0.5 A

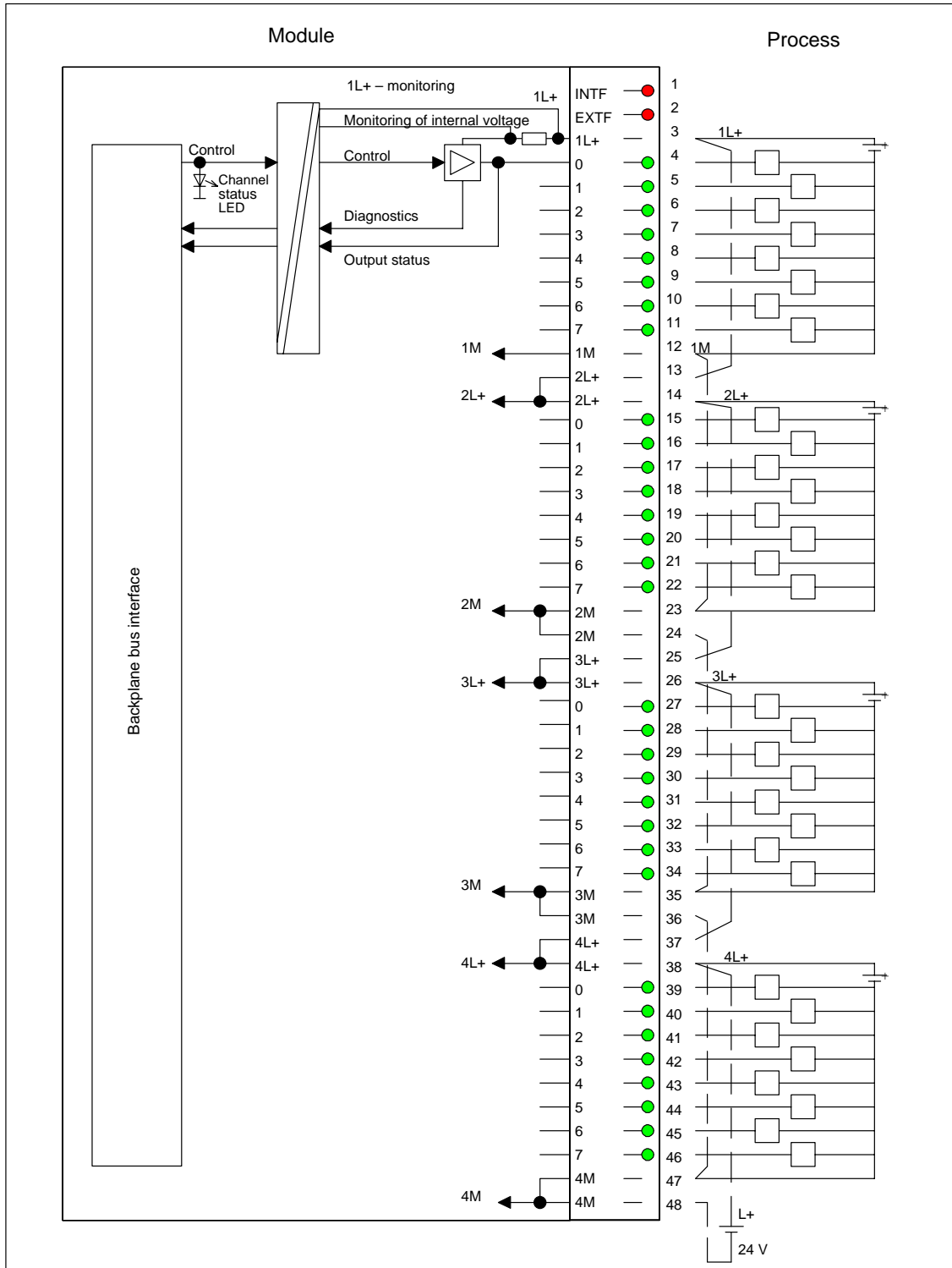

Figure 4-18 Terminal Assignment and Block Diagram of the SM 422; DO 32 × 24 VDC/0.5 A

Technical Specifications of the SM 422; DO 32 × 24 VDC/0.5 A

| Dimensions and Weight | |
|--|----------------------------|
| Dimensions W × H × D (in millimeters) | 25 × 290 × 210 |
| Weight | Approx. 600 g |
| Data for Specific Module | |
| Number of outputs | 32 |
| Length of cable | |
| • Unshielded | 600 m |
| • Shielded | 1000 m |
| Voltages, Currents, Potentials | |
| Power rated voltage of the electronics L+ | 24 VDC |
| Rated load voltage L+ | 24 VDC |
| Total current of the outputs (per group) | |
| Up to 40 °C | Max. 4 A |
| Up to 60 °C | Max. 2 A |
| Isolation | |
| • Between channels and backplane bus | Yes |
| • Between the channels in groups of | Yes 8 |
| Permitted potential difference | |
| • Between the different circuits | 75 VDC, 60 VAC |
| Insulation tested with | |
| • Channels against backplane bus and load voltage L+ | 500 VDC |
| • Between the outputs of the different groups | 500 VDC |
| Current consumption | |
| • From the backplane bus | Max. 200 mA |
| • Power supply and load voltage L+ (no load) | Max. 120 mA |
| Power dissipation of the module | Typ. 8 W |
| Status, Interrupts, Diagnostics | |
| Status display | Green LED per channel |
| Interrupts | |
| • Diagnostic Interrupt | Parameters can be assigned |
| • Hardware interrupt | Parameters can be assigned |

| Diagnostic functions | |
|--|---|
| • Monitoring of the load voltage | Yes |
| • Group error display | |
| – For internal fault | Red LED (INTF) |
| – For external fault | Red LED (EXTF) |
| • Diagnostic information readable | Yes |
| Monitoring for | |
| • Short circuit | > 1 A (typ.) |
| • Wire break | < 0.15 mA |
| Substitute value can be applied | Yes |
| Data for Selecting an Actuator | |
| Output voltage | |
| • At signal "1" | Min. L + (– 0.8 V) |
| Output current | |
| • At signal "1" | |
| Rated value | 0.5 A |
| Permitted range | 5 mA to 0.6 A |
| • At signal "0" (leakage current) | Max. 0.5 mA |
| Load resistor range | 48 Ω to 4 kΩ |
| Parallel connection of 2 outputs | |
| • For redundant triggering of a load | Possible (only outputs of the same group) |
| • To increase performance | Possible (only outputs of the same group) |
| Triggering a digital input | Possible |
| Switch rate | |
| • For resistive load | Max. 100 Hz |
| • For inductive load to IEC 947-5-1, DC 13 | Max. 2 Hz |
| • For lamp load | Max. 2 Hz |
| Limit (internal) of the inductive circuit interruption voltage up to | Typ. L + (– 45 V) |
| Short-circuit protection of the output | Electronically cyclic |
| • Threshold on | Typ. 0.75 A to 1.5 A |

| Time, Frequency | |
|---|-------------|
| Internal preparation time between backplane bus and input of the output driver ¹⁾ | |
| Up to hardware release 03 | |
| <ul style="list-style-type: none"> • independent of enable diagnostics/diagnostic interrupt/ substitute value | max. 100 µs |
| Up to hardware release 04 | |
| <ul style="list-style-type: none"> • without enable diagnostics/ diagnostic interrupt/ substitute value | max. 60 µs |
| <ul style="list-style-type: none"> • with enable diagnostics/ diagnostic interrupt/ substitute value | max. 100 µs |
| ¹⁾ The switching time of the output driver is added to the overall runtime on the module (< 100 µs for resistive load) | |

4.20.1 Assigning Parameters to the SM 422; DO 32 × 24 VDC/0.5 A

Parameter Assignment

You will find a description of the general procedure for assigning parameters to digital modules in Section 5.7.

Parameters of the SM 422; DO 32 × 24 VDC/0.5 A

You will find an overview of the parameters that you can set and their default settings for the SM 422; DO 32 × 24 VDC/0.5 A in the table below.

Table 4-18 Parameters of the SM 422; DO 32 × 24 VDC/0.5 A (6ES7422-7BL00-0AB0)

| Parameter | Value Range | Default ²⁾ | Parameter Type | Scope |
|---|--|-----------------------|----------------|---------------|
| Enable <ul style="list-style-type: none"> Diagnostic interrupt¹⁾ Destination CPU for interrupt | Yes/no | No | Dynamic | Module |
| | 1 to 4 | – | Static | Module |
| Reaction to CPU-STOP | Substitute a value (SV) Keep last value (KLV) | SV | Dynamic | Module |
| Diagnostics <ul style="list-style-type: none"> Wire break No load voltage L+/sensor supply Short circuit to M Short circuit to L+ | Yes/no | No | Static | Channel |
| | Yes/no | no | | Channel group |
| | Yes/no | No | | Channel |
| | Yes/no | No | | Channel |
| Substitute "1" | Yes/no | No | Dynamic | Channel |

1) If you use the module in ER-1/ER-2, you must set this parameter to "No" because the interrupt lines are not available in ER-1/ER-2.

2) Only in the CC (central controller) is it possible to start up the digital modules with the default settings.

4.20.2 Behavior of the SM 422; DO 32 × 24 VDC/0.5 A

Effect of Operating Mode and Supply Voltage on the Output Values

The output values of the SM 422; DO 32 × 24 VDC/0.5 A depend on the operating mode of the CPU and on the supply voltage of the module.

Table 4-19 Dependence of the Output Values on the Operating Mode of the CPU and on the Supply Voltage L+ of the SM 422; DO 32 × 24 VDC/0.5 A

| CPU Operating Mode | | Power Supply L+ to Digital Module | Output Value of Digital Module |
|--------------------|------|-----------------------------------|---|
| POWER ON | RUN | L+ exists | CPU value |
| | | L+ missing | 0 signal |
| | STOP | L+ exists | Substitute value/last value (0 signal preset) |
| | | L+ missing | 0 signal |
| POWER OFF | – | L+ exists | 0 signal |
| | | L+ missing | 0 signal |

Behavior in the Event of Failure of the Supply Voltage

The failure of the supply voltage of the SM 422; DO 32 × 24VDC/0.5 A is always indicated by the EXTf LED on the module. Furthermore, this information is made available on the module (entry in diagnosis).

Triggering of the diagnostic interrupt depends on the parameter assignment (see Section 4.20.1).

4.21 Digital Output Module SM 422; DO 8 × 120/230 VAC/5 A; (6ES7422-1FF00-0AA0)

Characteristics

The SM 422; DO 8 × 120/230 VAC/5 A has the following features:

- 8 outputs, isolated in groups of 1
- Output current 5 A
- 120/230 VAC rated load voltage

The status LEDs also indicate the system status even when the front connector is not inserted.

**Terminal Assignment and Block Diagram of the SM 422;
DO 8 × 120/230 VAC/5 A**

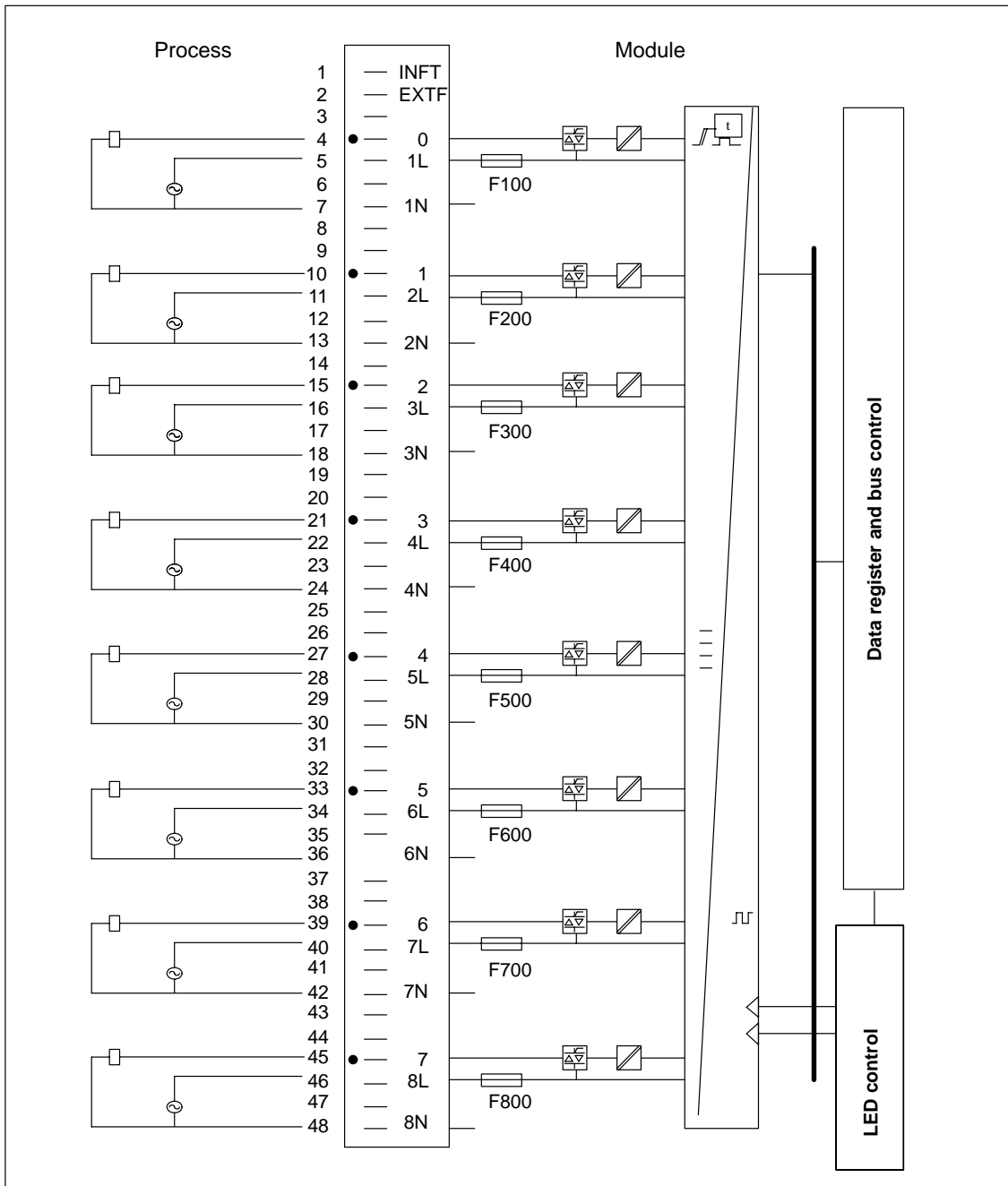

Figure 4-19 Terminal Assignment and Block Diagram of the SM 422; DO 8 × 120/230 VAC/5 A

Technical Specifications of the SM 422; DO 8 × 120/230 VAC/5 A

| Programming package | | – For external fault | | Red LED (EXTF) failed load voltage |
|--|----------------------------------|---|--|---------------------------------------|
| Associated programming package | As of STEP 7 V 2.0 | | | |
| Dimensions and Weight | | Data for Selecting an Actuator | | |
| Dimensions W × H × D (in millimeters) | 25 × 290 × 210 | Output voltage | | |
| Weight | Approx. 800 g | • At signal "1" | At maximum current min. L1 (–1.5 Vrms) | |
| Data for Specific Module | | | At maximum current min. L1 (–10.7 Vrms) | |
| Number of outputs | 8 | Output current | | |
| Length of cable | | • At signal "1" | | |
| • Unshielded | 600 m | Rated value | 5 A | |
| • Shielded | 1000 m | Permitted range | 10 mA to 5 A | |
| Voltages, Currents, Potentials | | Permitted surge current (per group) | Max. 50 A per cycle | |
| Rated load voltage L1 | 79 to 264 VAC | • At signal "0" (leakage current) | Max. 3.5 mA | |
| Permitted frequency range | 47 to 63 Hz | Output delay (for resistive load) | | |
| Total current of the outputs | | • From "0" to "1" | Not more than 1 AC scan cycle | |
| | With fan subassembly | • At "1" to "0" | Not more than 1 AC scan cycle | |
| Up to 40 °C | Max. 16 A 24 A | Minimum load current | 10 mA | |
| Up to 60 °C | Max. 8 A 20 A | Zero cross inhibit voltage | Max. 55 V | |
| Isolation | | Size of the motor starter | Max. size 5 to NEMA | |
| • Between channels and backplane bus | Yes | Lamp load | Max. 100 W | |
| • Between the channels in groups of | Yes 1 | Parallel connection of 2 outputs | | |
| Permitted potential difference | | • For redundant triggering of a load | Possible (only outputs connected to the same load) | |
| • Between the outputs of the different groups | 500 VAC | Triggering a digital input | Possible | |
| Insulation resistance | 4000 VAC | Switch rate | | |
| Current consumption | | • For resistive load | Max. 10 Hz | |
| • From the backplane bus | Max. 250 mA | • For inductive load to IEC 947-5-1, DC 13 | Max. 0.5 Hz | |
| • From load voltage L + (without load) | Max. 1.5 mA | • For lamp load | 1 Hz | |
| Power dissipation of the module | Typ. 16 W | Short-circuit protection of the output | Fuse, 8 A, 250 V (per output) | |
| Status, Interrupts, Diagnostics | | • Min. current required for fuse to blow | Min. 100 A | |
| Status display | Green LED per channel | • Max. response time | Max. 100 ms | |
| Interrupts | None | Replacement fuses | Fuse, 8 A, quick-acting | |
| Diagnostic functions | Parameters cannot be assigned | • Wickmann | 194-1800-0 | |
| • Group error display | | • Schurter | SP001.1013 | |
| – For internal fault | Red LED (INTF) failed fuse | • Littelfuse | 217.008 | |

Changing Fuses



Warning

This can result in injury.

If you change a fuse without removing the front connector of the module, you could be injured by an electric shock.

Consequently, always remove the front connector before you change the fuse.

4.22 Digital Output Module SM 422; DO 16 × 120/230 VAC/2 A; (6ES7422-1FH00-0AA0)

Characteristics

The SM 422; DO 16 × 120/230 VAC/2 A has the following features:

- 16 outputs, isolated in groups of 4
- 2 A output current
- 120/230 VAC rated load voltage

The status LEDs also indicate the system status even when the front connector is not inserted.

**Terminal Assignment and Block Diagram of the SM 422;
DO 16 × 120/230 VAC/2 A**

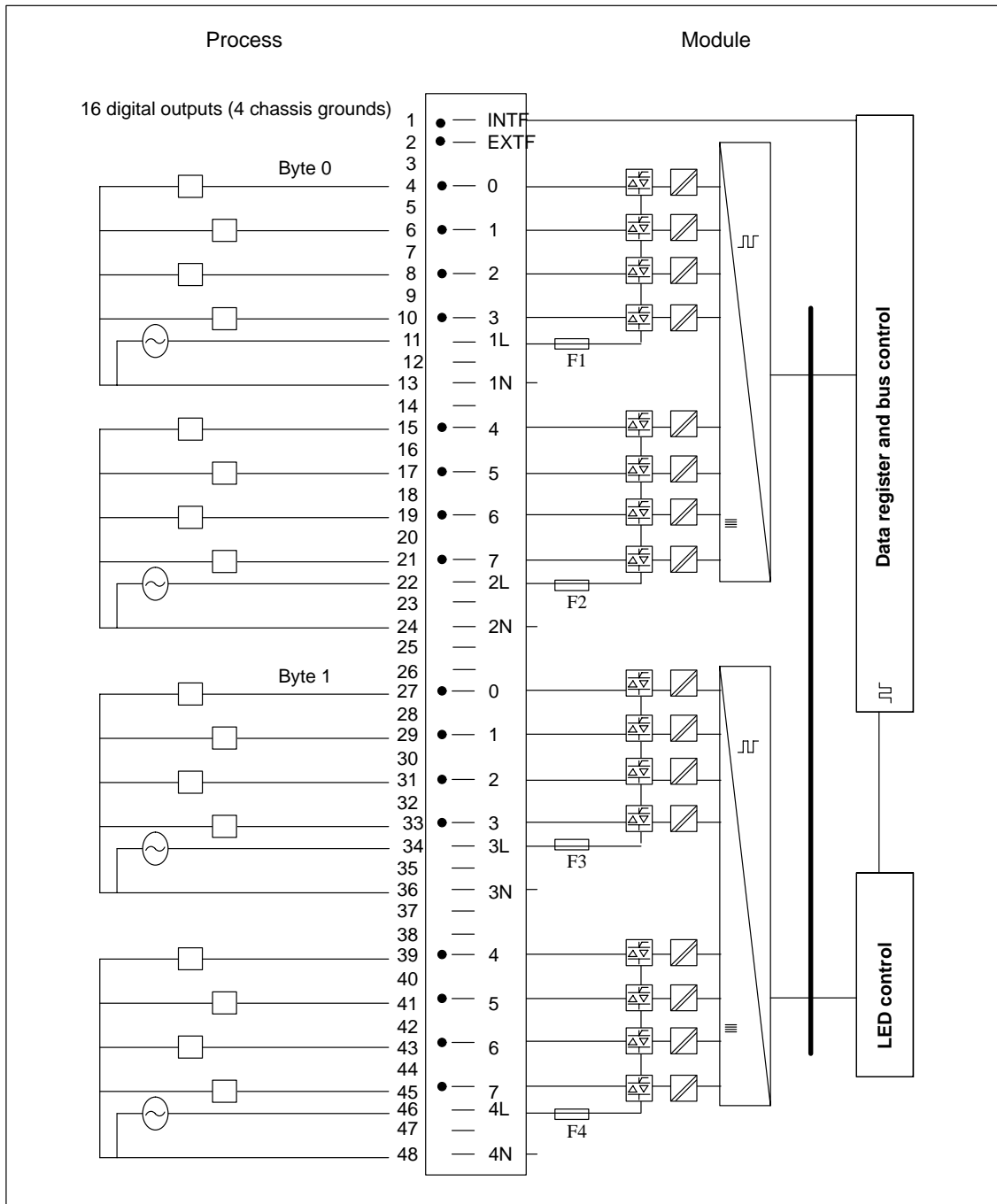

Figure 4-20 Terminal Assignment and Block Diagram of the SM 422; DO 16 × 120/230 VAC/2 A

Technical Specifications of the SM 422; DO 16 × 120/230 VAC/2 A

| Programming package | | Data for Selecting an Actuator | |
|--|---------------------------------------|--|---|
| Associated programming package | As of STEP 7 V 2.0 | Output voltage | |
| Dimensions and Weight | | • At signal "1" | At maximum current min. L1 (–1.3 Vrms) At minimum current min. L1 (–18.1 Vrms) |
| Dimensions W × H × D (in millimeters) | 25 × 290 × 210 | Output current | |
| Weight | Approx. 800 g | • At signal "1" | |
| Data for Specific Module | | Rated value | 2 A |
| Number of outputs | 16 | Permitted range | 10 mA to 2 A |
| Length of cable | | Permitted surge current (per group) | Max. 50 A per cycle |
| • Unshielded | 600 m | • At signal "0" (leakage current) | Max. 2.6 mA |
| • Shielded | 1000 m | Output delay (for resistive load) | |
| Voltages, Currents, Potentials | | • From "0" to "1" | Max. 1 ms |
| Rated load voltage L1 | 79 to 264 VAC | • At "1" to "0" | Not more than 1 AC scan cycle |
| Permitted frequency range | 47 to 63 Hz | Minimum load current | 10 mA |
| Total current of the outputs (per group) | | Zero cross inhibit voltage | Non-zero cross outputs |
| | With fan subassembly | Size of the motor starter | Max. size 5 to NEMA |
| Up to 40 °C | Max. 4 A 6 A | Lamp load | Max. 50 W |
| Up to 60 °C | Max. 2 A 5 A | Parallel connection of 2 outputs | |
| Isolation | | • For redundant triggering of a load | Possible (only outputs connected to the same load) |
| • Between channels and backplane bus | Yes | Triggering a digital input | Possible |
| • Between the channels In groups of | Yes 4 | Switch rate | |
| Permitted potential difference | | • For resistive load | Max. 10 Hz |
| • Between the outputs of the different groups | 500 VAC | • For inductive load, to IEC 947-5-1, AC 15 | Max. 0.5 Hz |
| Insulation resistance | 4000 VAC | • For lamp load | 1 Hz |
| Current consumption | | Short-circuit protection of the output | Fuse, 8 A, 250 V (per group) |
| • From the backplane bus | Max. 400 mA | • Min. current required for fuse to blow | Min. 100 A |
| • From load voltage L + (without load) | 1.5 mA | • Max. response time | Max. 100 ms |
| Power dissipation of the module | Typ. 16 W | Replacement fuses | Fuse, 8 A, quick-acting |
| Status, Interrupts, Diagnostics | | • Wickmann | 194-1800-0 |
| Status display | Green LED per channel | • Schurter | SP001.1013 |
| Interrupts | None | • Littelfuse | 217.008 |
| Diagnostic functions | Parameters cannot be assigned | | |
| • Group error display | | | |
| – For internal fault | Red LED (INTF) failed fuse | | |
| – For external fault | Red LED (EXTF) failed load voltage | | |

Changing Fuses



Warning

This can result in injury.

If you change a fuse without removing the front connector of the module, you could be injured by an electric shock.

Consequently, always remove the front connector before you change the fuse.

4.23 Digital Output Module SM 422; DO 16 × 20-120 VAC/2 A; (6ES7422-5EH00-0AB0)

Characteristics

The SM 422; DO 16 × 20-120 VAC/2 A has the following features:

- 16 outputs, isolated in groups of 1
- 2 A output current
- Rated load voltage 20 VAC to 120 VAC
- Group error display for internal faults (INTF) and external faults (EXTF)
- Programmable diagnostics
- Programmable diagnostic interrupt
- Programmable substitute value output

Terminal Assignment Diagram of the SM 422; DO 16 × 20-120 VAC/2 A

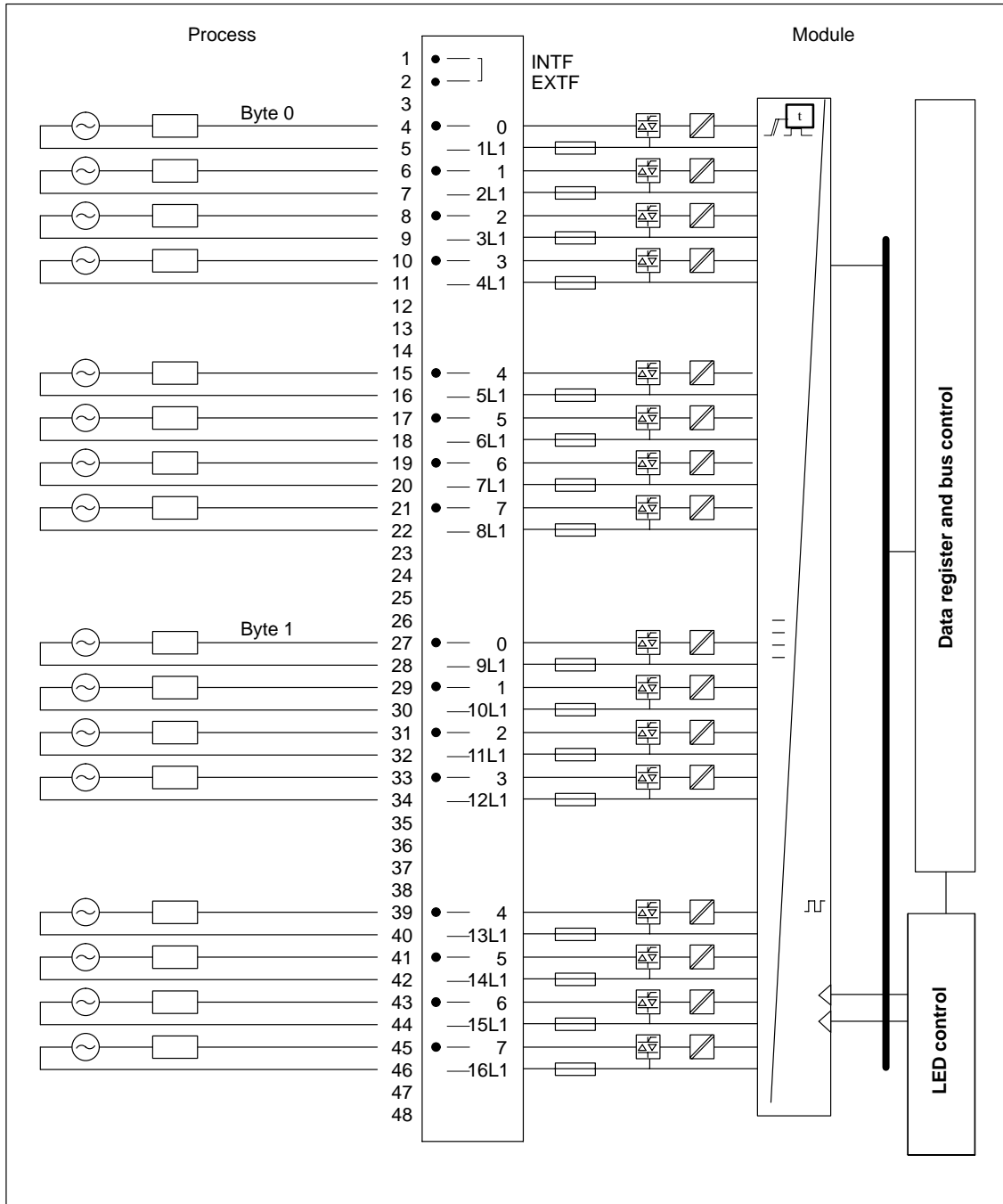

Figure 4-21 Terminal Assignment Diagram of the SM 422; DO 16 × 20-120 VAC/2 A

Technical Specifications of the SM 422; DO 16 × 20-120 VAC/2 A

| Dimensions and Weight | | • Diagnostic information readable | | Possible |
|---|----------------------------|--|-------------------|---|
| Dimensions W × H × D (in millimeters) | 25 × 290 × 210 | Substitute value can be applied | Yes, programmable | |
| Weight | Approx. 800 g | Data for Selecting an Actuator | | |
| Data for Specific Module | | Output voltage | | |
| Number of outputs | 16 | • At signal "1" | | L1 (–1.5 Vrms) |
| Length of cable | | Output current | | |
| • Unshielded | Max. 600 m | • At signal "1" | | |
| • Shielded | Max. 1000 m | Rated value | | 2 A |
| Voltages, Currents, Potentials | | Permitted range | | 100 mA to 2 A |
| Rated load voltage L+ | 20 to 132 VAC | Permitted surge current (per group) | | Max. 20 A/2 cycles |
| • Permitted frequency range | 47 Hz to 63 Hz | • At signal "0" (leakage current) | | Max. 2.5 mA at 30 V Max. 4.5 mA at 132 V |
| Total current of the outputs | | Output delay (for resistive load) | | |
| | With fan subassembly | • From "0" to "1" | | 1 ms |
| Up to 40 °C | Max. 16 A | • At "1" to "0" | | 1 AC cycle |
| Up to 60 °C | Max. 7 A | Zero cross inhibit voltage | | Non-zero cross outputs |
| Isolation | | Size of the motor starter | | Max. size 5 to NEMA |
| • Between channels and backplane bus | Yes | Lamp load | | Max. 50 W |
| • Between the channels in groups of | Yes 1 | Parallel connection of 2 outputs | | |
| Permitted potential difference | | • For redundant triggering of a load | | Possible (only outputs of the same group) |
| • Between M _{internal} and the outputs | 120 VAC | • To increase performance | | Not possible |
| • Between the outputs of the different groups | 250 VAC | Triggering a digital input | | Possible |
| Insulation tested with | 1500 VDC | Switch rate | | |
| Current consumption | | • For resistive load | | Max. 10 Hz |
| • From the backplane bus | Max. 600 mA | • For inductive load to IEC 947-5-1, DC 13 | | Max. 0.5 Hz |
| • From load voltage L + (without load) | Max. 0 mA | • For lamp load | | 1 Hz |
| Power dissipation of the module | Typ. 20 W | Short-circuit protection of the output | | Fuse 8A/125 V 2AG (per output) |
| Status, Interrupts, Diagnostics | | • Min. current required for fuse to blow | | Min. 40 A |
| Status display | Green LED per channel | • Max. response time | | Typ. 33 ms |
| Interrupts | | Replacement fuses | | Fuse, 8 A, quick-acting |
| • Diagnostic Interrupt | Parameters can be assigned | • Littelfuse | | 225.008 |
| Diagnostic functions | Parameters can be assigned | | | |
| • Group error display | | | | |
| – For internal fault | Red LED (INTF) | | | |
| – For external fault | Red LED (EXTF) | | | |

Changing Fuses



Warning

This can result in injury.

If you change a fuse without removing the front connector of the module, you could be injured by an electric shock.

Consequently, always remove the front connector before you change the fuse.

4.23.1 Assigning Parameters to the SM 422; DO 16 × 20-120 VAC/2 A

Parameter Assignment

You will find a description of the general procedure for assigning parameters to digital modules in Section 5.7.

Parameters of the SM 422; DO 16 × 20-120 VAC/2 A

You will find an overview of the parameters you can set and their default settings for the SM 422; DO 16 × 20-120 VAC/2 A in the following table.

Table 4-20 Parameters of the SM 422; DO 16 × 20-120 VAC/2 A

| Parameter | Value Range | Default ²⁾ | Parameter Type | Scope |
|---|--|-----------------------|----------------|---------|
| Enable <ul style="list-style-type: none"> Diagnostic interrupt¹⁾ Destination CPU for interrupt | Yes/no | No | Dynamic | Module |
| | 1 to 4 | – | Static | Module |
| Reaction to CPU STOP | Substitute a value (SV) Keep last value (KLV) | SV | Dynamic | Module |
| Diagnostics <ul style="list-style-type: none"> Fuse blown | Yes/no | No | Static | Channel |
| Enable substitute value "1" | Yes/no | No | Dynamic | Channel |

1) If you use the module in ER-1/ER-2, you must set this parameter to "No" because the interrupt lines are not available in ER-1/ER-2.

2) Only in the CC (central controller) is it possible to start up the digital modules with the default settings.

4.24 Relay Output Module SM 422; DO 16 × 30/230 VUC/Rel. 5 A; (6ES7422-1HH00-0AA0)

Characteristics

The SM 422; DO 16 × 30/230 VUC/Rel. 5 A has the following features:

- 16 outputs, isolated in 8 groups of 2
- Output current 5 A
- Rated load voltage 230 VAC/ 125 VDC

The status LEDs also indicate the system status even when the front connector is not inserted.

**Terminal Assignment and Block Diagram of the SM 422;
DO 16 × 30/230 VUC/Rel. 5 A**

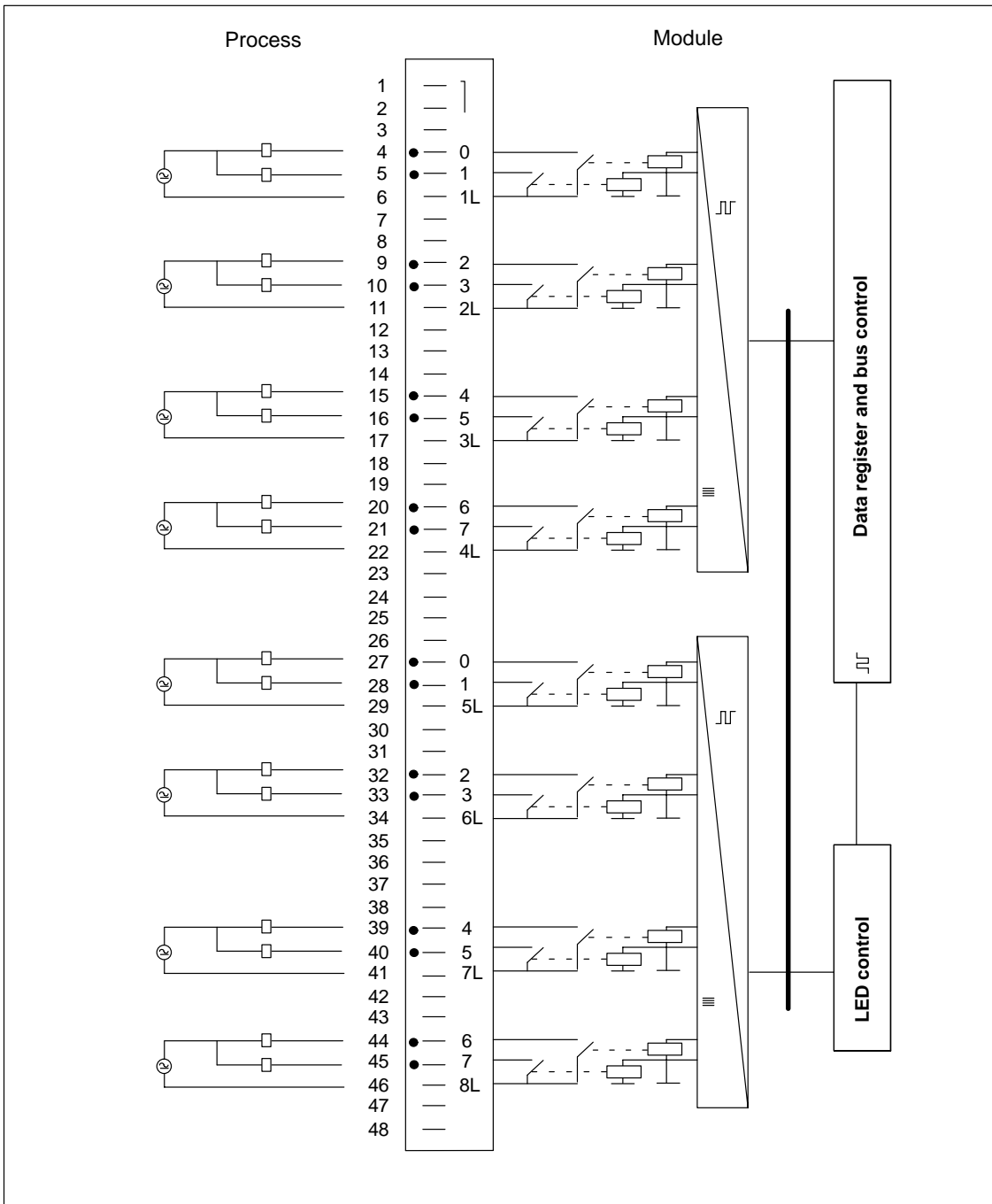

Figure 4-22 Terminal Assignment and Block Diagram of the SM 422; DO 16 × 30/230 VUC/Rel. 5 A

Technical Specifications of the SM 422; DO 16 × 30/230 VUC/Rel. 5 A

| Programming package | | Data for Selecting an Actuator | | | | | | | | | | | | | | | | | | |
|--|---|--|-------------------------|--|--|---------|---------|------------------------------|-------------------------|-------|-----------|---------------------|-------|----------|---------|-------|----------|---------|-------|-----------|
| Associated programming package | As of STEP 7 V 2.0 package | Continuous thermal current | Max. 5 A | | | | | | | | | | | | | | | | | |
| Dimensions and Weight | | Minimum load current | 10 mA | | | | | | | | | | | | | | | | | |
| Dimensions W × H × D (in millimeters) | 25 × 290 × 210 | External fuse for relay outputs | Fuse, 6 A, quick-acting | | | | | | | | | | | | | | | | | |
| Weight | Approx. 700 g | Switching capacity and lifetime of the contacts | | | | | | | | | | | | | | | | | | |
| Data for Specific Module | | <ul style="list-style-type: none"> For resistive load <table border="1"> <thead> <tr> <th>Voltage</th> <th>Current</th> <th>No. of switching cyc. (typ.)</th> </tr> </thead> <tbody> <tr> <td>30 VDC</td> <td>5.0 A</td> <td>0.18 mill</td> </tr> <tr> <td>60 VDC</td> <td>1.2 A</td> <td>0.1 mill</td> </tr> <tr> <td>125 VDC</td> <td>0.2 A</td> <td>0.1 mill</td> </tr> <tr> <td>230 VAC</td> <td>5.0 A</td> <td>0.18 mill</td> </tr> </tbody> </table> | | | | Voltage | Current | No. of switching cyc. (typ.) | 30 VDC | 5.0 A | 0.18 mill | 60 VDC | 1.2 A | 0.1 mill | 125 VDC | 0.2 A | 0.1 mill | 230 VAC | 5.0 A | 0.18 mill |
| Voltage | Current | No. of switching cyc. (typ.) | | | | | | | | | | | | | | | | | | |
| 30 VDC | 5.0 A | 0.18 mill | | | | | | | | | | | | | | | | | | |
| 60 VDC | 1.2 A | 0.1 mill | | | | | | | | | | | | | | | | | | |
| 125 VDC | 0.2 A | 0.1 mill | | | | | | | | | | | | | | | | | | |
| 230 VAC | 5.0 A | 0.18 mill | | | | | | | | | | | | | | | | | | |
| Number of outputs | 16 | <ul style="list-style-type: none"> For inductive load to IEC 947-5-1 13 DC/15 AC <table border="1"> <thead> <tr> <th>Voltage</th> <th>Current</th> <th>No. of switching cyc. (typ.)</th> </tr> </thead> <tbody> <tr> <td>30 VDC (τ=7 ms max.)</td> <td>5.0 A</td> <td>0.1 mill</td> </tr> <tr> <td>230 VAC (pf=0.4)</td> <td>5.0 A</td> <td>0.1 mill</td> </tr> </tbody> </table> | | | | Voltage | Current | No. of switching cyc. (typ.) | 30 VDC (τ=7 ms max.) | 5.0 A | 0.1 mill | 230 VAC (pf=0.4) | 5.0 A | 0.1 mill | | | | | | |
| Voltage | Current | No. of switching cyc. (typ.) | | | | | | | | | | | | | | | | | | |
| 30 VDC (τ=7 ms max.) | 5.0 A | 0.1 mill | | | | | | | | | | | | | | | | | | |
| 230 VAC (pf=0.4) | 5.0 A | 0.1 mill | | | | | | | | | | | | | | | | | | |
| Length of cable | | Size of the motor starter | | | | | | | | | | | | | | | | | | |
| <ul style="list-style-type: none"> Unshielded Shielded | Max. 600 m Max. 1000 m | Max. size 5 to NEMA Max. 60 W | | | | | | | | | | | | | | | | | | |
| Voltages, Currents, Potentials | | Contact protection (internal) | | | | | | | | | | | | | | | | | | |
| Total current of the outputs (per group) | | None | | | | | | | | | | | | | | | | | | |
| | With fan subassembly | Connecting two outputs in parallel | | | | | | | | | | | | | | | | | | |
| Up to 40 °C | Max. 10 A 10 A | <ul style="list-style-type: none"> For redundant actuation of a load | | | | | | | | | | | | | | | | | | |
| Up to 60 °C | Max. 5 A 10 A | <ul style="list-style-type: none"> To increase performance | | | | | | | | | | | | | | | | | | |
| Isolation | | Triggering a digital input | | | | | | | | | | | | | | | | | | |
| <ul style="list-style-type: none"> Between channels and backplane bus Between the channels | Yes Yes | Possible | | | | | | | | | | | | | | | | | | |
| In groups of | 2 | Switch rate | | | | | | | | | | | | | | | | | | |
| Permitted potential differences: | | <ul style="list-style-type: none"> Mechanical For resistive load For inductive load to IEC 947-5-1, 13 DC/15 AC For lamp load | | | | | | | | | | | | | | | | | | |
| <ul style="list-style-type: none"> Between the outputs of the different groups | 500 VAC | Max. 20 Hz Max. 10 Hz 1 Hz 1 Hz | | | | | | | | | | | | | | | | | | |
| Insulation resistance | 4000 VAC | | | | | | | | | | | | | | | | | | | |
| Current consumption | | | | | | | | | | | | | | | | | | | | |
| <ul style="list-style-type: none"> From the backplane bus | Max. 1 A | | | | | | | | | | | | | | | | | | | |
| Power dissipation of the module | Typ. 4.5 W | | | | | | | | | | | | | | | | | | | |
| Status, Interrupts, Diagnostics | | | | | | | | | | | | | | | | | | | | |
| Status display | Green LED per channel | | | | | | | | | | | | | | | | | | | |
| Interrupt | None | | | | | | | | | | | | | | | | | | | |
| Diagnostic functions | None | | | | | | | | | | | | | | | | | | | |
| Relay Features | | | | | | | | | | | | | | | | | | | | |
| Relay response times | | | | | | | | | | | | | | | | | | | | |
| <ul style="list-style-type: none"> Power up Power down | Max. 10 ms Typ. 5.5 ms Max. 5 ms Typ. 3 ms | | | | | | | | | | | | | | | | | | | |
| Debouncing time | Typ. 0.5 ms | | | | | | | | | | | | | | | | | | | |

Note

Use a suppressor circuit in environments with high humidity and where sparks might occur at the relay contacts. This will increase the life of the relay contacts.

To do this, connect an RC element or a varistor parallel to the relay contacts or to the load. The dimensions depend on the size of the load (see Chapter 4 of the installation manual).

Analog Modules

Structure of the Chapter

The present chapter is broken down into the following subjects:

1. Overview containing the modules that are available here and a description
2. Information that is generally available – in other words, affects all analog modules (such as parameter assignment and diagnostics)
3. Information that refers to specific modules (for example, characteristics, diagram of connections and block diagram, technical specifications and special characteristics of the module):
 - a) For analog input modules
 - b) For analog output modules

STEP 7 Blocks for Analog Functions

You can use blocks FC 100 to FC 111 to read and output analog values in *STEP 7*. You will find the FCs in the standard library of *STEP 7* in the subdirectory called “S5-S7 Converting Blocks” (for a description refer to the *STEP 7* online help system for the FCs).

Additional Information

Appendix A describes the structure of the parameter records (data records 0 and 1) in the system data. You must be familiar with this structure if you want to modify the parameters of the modules in the *STEP 7* user program.

Appendix B describes the structure of the diagnostic data (data records 0, 1) in the system data. You must be familiar with this structure if you want to evaluate the diagnostic data of the modules in the *STEP 7* user program.

Chapter Overview

| Section | Description | Page |
|---------|--|-------|
| 5.1 | Module Overview | 5-3 |
| 5.2 | Sequence of Steps from Choosing to Commissioning the Analog Modules | 5-6 |
| 5.3 | Analog Value Representation | 5-7 |
| 5.4 | Setting the Measuring Method and Measuring Ranges of the Analog Input Channels | 5-28 |
| 5.5 | Behavior of the Analog Modules | 5-31 |
| 5.6 | Conversion, Cycle, Setting and Response Time of Analog Modules | 5-35 |
| 5.7 | Analog Module Parameter Assignment | 5-39 |
| 5.8 | Connecting Sensors to Analog Inputs | 5-43 |
| 5.9 | Connecting Voltage Sensors | 5-46 |
| 5.10 | Connecting Current Sensors | 5-47 |
| 5.11 | Connecting Resistance Thermometers and Resistors | 5-50 |
| 5.12 | Connecting Thermocouples | 5-53 |
| 5.13 | Connecting Loads/Actuators to Analog Outputs | 5-59 |
| 5.14 | Connecting Loads/Actuators to Voltage Outputs | 5-60 |
| 5.15 | Connecting Loads/Actuators to Current Outputs | 5-62 |
| 5.16 | Diagnostics of the Analog Modules | 5-63 |
| 5.17 | Analog Module Interrupts | 5-67 |
| 5.18 | Analog Input Module SM 431; AI 8 × 13 Bit; (6ES7431-1KF00-0AB0) | 5-70 |
| 5.19 | Analog Input Module SM 431; AI 8 × 14 Bit; (6ES7431-1KF10-0AB0) | 5-77 |
| 5.20 | Analog Input Module SM 431; AI 8 × 14 Bit; (6ES7431-1KF20-0AB0) | 5-90 |
| 5.21 | Analog Input Module SM 431; AI 16 × 13 Bit; (6ES7431-0HH00-0AB0) | 5-99 |
| 5.22 | Analog Input Module SM 431; AI 16 × 16 Bit; (6ES7431-7QH00-0AB0) | 5-107 |
| 5.23 | Analog Input Module SM 431; AI 8 × RTD × 16 Bit; (6ES7431-7KF10-0AB0) | 5-122 |
| 5.24 | Analog Input Module SM 431; AI 8 × 16 Bit; (6ES7431-7KF00-0AB0) | 5-130 |
| 5.25 | Analog Output Module SM 432; AO 8 × 13 Bit; (6ES7432-1HF00-0AB0) | 5-141 |

5.1 Module Overview

Introduction

The following tables summarize the most important characteristics of the analog modules. This overview is intended to make it easy to choose the suitable module for your task.

Table 5-1 Analog Input Modules: Characteristics at a Glance

| Module \ Characteristics | SM 431; AI 8 × 13 Bit (-1KF00-) | SM 431; AI 8 × 14 Bit (-1KF10-) | SM 431; AI 8 × 14 Bit (-1KF20-) | SM 431; AI 13 × 16 Bit (-0HH0-) | SM 431; AI 16 × 16 Bit (-7QH00-) | SM 431; AI 8 × RTD 16 Bit (-7KF10-) | SM 431; AI 8 × 16 Bit (-7KF00-) |
|--|---|---|---|--|--|--|--|
| Number of Inputs | 8 AI U/I measurement 4 AI for resistance measurement | 8 AI for U/I measurement 4 AI for resistance/temperature measurement | 8 AI for U/I measurement 4 AI for resistance measurement | 16 inputs | 16 AI for U/I/temperature measurement 8 AI for resistance measurement | 8 inputs | 8 inputs |
| Resolution | 13 bits | 14 bits | 14 bits | 13 bits | 16 bits | 16 bits | 16 bits |
| Measuring Method | Voltage Current Resistors | Voltage Current Resistors Temperature | Voltage Current Resistors | Voltage Current | Voltage Current Resistors Temperature | Resistors | Voltage Current Temperature |
| Measuring Principle | Integrating | Integrating | Instantaneous value encoding | Integrating | Integrating | Integrating | Integrating |
| Programmable Diagnostics | No | No | No | No | Yes | Yes | Yes |
| Diagnostic Interrupt | No | No | No | No | Adjustable | Yes | Yes |
| Limit value Monitoring | No | No | No | No | Adjustable | Adjustable | Adjustable |
| Hardware Interrupt upon Limit Violation | No | No | No | No | Adjustable | Adjustable | Adjustable |
| Hardware Interrupt at End of Cycle | No | No | No | No | Adjustable | No | No |
| Potential Relationships | Analog section isolated from CPU | | | Non-isolated | Analog section isolated from CPU | | |

Table 5-1 Analog Input Modules: Characteristics at a Glance, continued

| Module Characteristics | SM 431; AI 8 × 13 Bit (-1KF00-) | SM 431; AI 8 × 14 Bit (-1KF10-) | SM 431; AI 8 × 14 Bit (-1KF20-) | SM 431; AI 13 × 16 Bit (-0HH0-) | SM 431; AI 16 × 16 Bit (-7QH00-) | SM 431; AI 8 × RTD 16 Bit (-7KF10-) | SM 431; AI 8 × 16 Bit (-7KF00-) |
|---|--|--|---|--|--|--|--|
| Max. Permissible Common Mode Voltage | Between the channels or between the reference potential of the connected sensors and M _{ANA} : 30 VAC | Between the channels or between the channel and central ground point: 120 VAC | Between the channels or between the reference potential of the connected sensors and M _{ANA} : 8 VAC | Between the channels or between the reference potential of the connected sensor and central ground point: 2 VDC/AC | Between the channels or between the channel and central ground point: 120 VAC | Between channel and central ground point: 120 VAC | Between the channels or between the channel and central ground point: 120 VAC |
| Ext. Power Supply Necessary | No | 24 VDC (only with current, 2-DMU) | 24 VDC (only with current, 2-DMU) | 24 VDC (only with current, 2-DMU) | 24 VDC (only with current, 2-DMU) | No | No |
| Special Features | – | Suitable for temperature measurement Temperature sensor types can be parameterized Linearization of the sensor characteristic curves Smoothing of the measured values | Rapid A/D change, suitable for highly dynamic processes Smoothing of the measured values | – | Suitable for temperature measurement Temperature sensor types can be parameterized Linearization of the sensor characteristic curves Smoothing of the measured values | Resistance thermometer can be parameterized Linearization of the sensor characteristic curves Smoothing of the measured values | Internal measuring resistor Field connection with internal reference temperature (included with the module) Smoothing of the measured values |

2-DMU

Two-wire transmitter

Table 5-2 Analog Output Modules: Characteristics at a Glance

| Module Characteristics | SM 432; AO 8 × 13 Bit (-1HF00-) |
|---------------------------|---|
| Number of outputs | 8 outputs |
| Resolution | 13 bits |
| Output type | Channel by channel: <ul style="list-style-type: none"> • Voltage • Current |
| Programmable diagnostics | No |
| Diagnostic Interrupt | No |
| Substitute value output | No |
| Potential relationships | Analog section isolated from: <ul style="list-style-type: none"> • CPU • The load voltage |

Table 5-2 Analog Output Modules: Characteristics at a Glance

| Module | SM 432; AO 8 × 13 Bit (-1HF00-) |
|--------------------------------------|---|
| Characteristics | |
| Max. permissible common mode voltage | Between the channels and the channels against M _{ANA} 3 VDC |
| Special Features | – |

5.2 Sequence of Steps from Choosing to Commissioning the Analog Modules

Introduction

The following table contains the tasks that you have to perform one after the other to commission analog modules successfully.

The sequence of steps is a suggestion, but you can perform individual steps either earlier or later (for example, assign parameters to the module) or install other modules or install, commission etc. other modules in between times.

Sequence of Steps

Table 5-3 Sequence of Steps from Choosing to Commissioning the Analog Module

| Step | Procedure | Refer To... |
|------|---|---|
| 1. | Select the module | Section 5.1 and specific module section from Section 5.18 |
| 2. | With some analog input modules: set the measuring method and measuring range by means of the measuring range module | Section 5.4 |
| 3. | Install the module in the SIMATIC S7 network | "Installation" section in the manual for the programmable controller being used: <ul style="list-style-type: none"> S7-400/M7-400 Programmable Controllers, Hardware and Installation |
| 4. | Assign parameters to module | Section 5.7 |
| 5. | Connect measuring sensor or loads to module | Sections 5.8 to 5.15 |
| 6. | Commission configuration | "Commissioning" section in the manual for the programmable controller being used: <ul style="list-style-type: none"> S7-400/M7-400 Programmable Controllers, Hardware and Installation |
| 7. | If commissioning was not successful, diagnose configuration | Section 5.16 |

5.3 Analog Value Representation

Introduction

This section describes the analog values for all the measuring ranges and output ranges which you can use with the analog modules.

Converting Analog Values

Analog input modules convert the analog process signal into digital form.

Analog output modules convert the digital output value into an analog signal.

Analog Value Representation with 16-Bit Resolution

The digitized analog value is the same for both input and output values having the same nominal range. The analog values are represented as a fixed-point number in two's complement. The resulting assignment is as follows:

| | | | | | | | | | | | | | | | | |
|---------------|----------|----------|----------|----------|----------|----------|-------|-------|-------|-------|-------|-------|-------|-------|-------|-------|
| Bit | 15 | 14 | 13 | 12 | 11 | 10 | 9 | 8 | 7 | 6 | 5 | 4 | 3 | 2 | 1 | 0 |
| Value of bits | 2^{15} | 2^{14} | 2^{13} | 2^{12} | 2^{11} | 2^{10} | 2^9 | 2^8 | 2^7 | 2^6 | 2^5 | 2^4 | 2^3 | 2^2 | 2^1 | 2^0 |

Bit 15 Can Be Interpreted as a Sign

The sign of the analog value is always contained in bit number 15:

- "0" → +
- "1" → -

Resolution Less than 16 Bits

If the resolution of an analog module has fewer than 16 bits, the analog value is stored left-justified on the module. The lower-order bit positions not used are padded with zeros ("0").

Example

In the following example you can see how the positions not padded with “0” are written for low resolution.

Table 5-4 Example: Bit Pattern of a 16-Bit and a 13-Bit Analog Value

| Resolution | Analog Value | | | | | | | | | | | | | | | |
|---------------------|--------------|----|----|----|----|----|---|---|---|---|---|---|---|----------|----------|----------|
| Bit | 15 | 14 | 13 | 12 | 11 | 10 | 9 | 8 | 7 | 6 | 5 | 4 | 3 | 2 | 1 | 0 |
| 16-bit analog value | 0 | 1 | 0 | 0 | 0 | 1 | 1 | 0 | 0 | 1 | 1 | 1 | 0 | 0 | 1 | 1 |
| 13-bit analog value | 0 | 1 | 0 | 0 | 0 | 1 | 1 | 0 | 0 | 1 | 1 | 1 | 0 | 0 | 0 | 0 |

5.3.1 Analog Value Representation for Analog Input Channels

Introduction

The tables in this chapter contain the measured value representations for the various measuring ranges of the analog input modules. The values in the tables apply to all modules with the corresponding measuring ranges.

Notes for Readers of the Tables

Tables 5-6 to 5-8 contain the binary representation of the measured values.

Since the binary representation of the measured values is always the same, starting at 5-9 these tables only contain the measured values and the units.

Measured-Value Resolution

The resolution of the analog values can differ depending on the analog module and its parameter assignment. With resolutions < 16 bit, the bits marked with “x” are set to “0”.

Note: This resolution doesn’t apply to temperature values. The changed temperature values are the result of recalculation in the analog module (see Tables 5-16 to 5-30).

Table 5-5 Possible Resolutions of the Analog Values

| Resolution in Bits | Units | | Analog Value | |
|-----------------------|---------|-----------------|-----------------|----------------|
| | Decimal | Hexadecimal | High-Order Byte | Low-Order Byte |
| 9 | 128 | 80 _H | 00000000 | 1xxxxxxx |
| 10 | 64 | 40 _H | 00000000 | 01xxxxxx |
| 11 | 32 | 20 _H | 00000000 | 001xxxxx |
| 12 | 16 | 10 _H | 00000000 | 0001xxxx |
| 13 | 8 | 8 _H | 00000000 | 00001xxx |
| 14 | 4 | 4 _H | 00000000 | 000001xx |
| 15 | 2 | 2 _H | 00000000 | 0000001x |
| 16 | 1 | 1 _H | 00000000 | 00000001 |

Binary Representation of the Input Ranges

The input ranges shown in Tables 5-6 to 5-8 are defined in two's complement representation:

Table 5-6 Bipolar Input Ranges

| Units | Measured Value in % | Data Word | | | | | | | | | | | | | | | | Range |
|--------|---------------------|-----------------|-----------------|-----------------|-----------------|-----------------|-----------------|----------------|----------------|----------------|----------------|----------------|----------------|----------------|----------------|----------------|----------------|-------------|
| | | 2 ¹⁵ | 2 ¹⁴ | 2 ¹³ | 2 ¹² | 2 ¹¹ | 2 ¹⁰ | 2 ⁹ | 2 ⁸ | 2 ⁷ | 2 ⁶ | 2 ⁵ | 2 ⁴ | 2 ³ | 2 ² | 2 ¹ | 2 ⁰ | |
| 32767 | > 118.515 | 0 | 1 | 1 | 1 | 1 | 1 | 1 | 1 | 1 | 1 | 1 | 1 | 1 | 1 | 1 | 1 | Over-flow |
| 32511 | 117.589 | 0 | 1 | 1 | 1 | 1 | 1 | 1 | 0 | 1 | 1 | 1 | 1 | 1 | 1 | 1 | 1 | Over-range |
| 27649 | > ≥ 100.004 | 0 | 1 | 1 | 0 | 1 | 1 | 0 | 0 | 0 | 0 | 0 | 0 | 0 | 0 | 0 | 1 | |
| 27648 | 100.000 | 0 | 1 | 1 | 0 | 1 | 1 | 0 | 0 | 0 | 0 | 0 | 0 | 0 | 0 | 0 | 0 | Rated range |
| 1 | 0.003617 | 0 | 0 | 0 | 0 | 0 | 0 | 0 | 0 | 0 | 0 | 0 | 0 | 0 | 0 | 0 | 1 | |
| 0 | 0.000 | 0 | 0 | 0 | 0 | 0 | 0 | 0 | 0 | 0 | 0 | 0 | 0 | 0 | 0 | 0 | 0 | |
| -1 | -0.003617 | 1 | 1 | 1 | 1 | 1 | 1 | 1 | 1 | 1 | 1 | 1 | 1 | 1 | 1 | 1 | 1 | |
| -27648 | -100.000 | 1 | 0 | 0 | 1 | 0 | 1 | 0 | 0 | 0 | 0 | 0 | 0 | 0 | 0 | 0 | 0 | |
| -27649 | ≤ - 100.004 | 1 | 0 | 0 | 1 | 0 | 0 | 1 | 1 | 1 | 1 | 1 | 1 | 1 | 1 | 1 | 1 | Under range |
| -32512 | -117.593 | 1 | 0 | 0 | 0 | 0 | 0 | 0 | 1 | 0 | 0 | 0 | 0 | 0 | 0 | 0 | 0 | |
| -32768 | ≤ - 117.596 | 1 | 0 | 0 | 0 | 0 | 0 | 0 | 0 | 0 | 0 | 0 | 0 | 0 | 0 | 0 | 0 | Under-flow |

Table 5-7 Unipolar Input Ranges

| Units | Measured Value in % | Data Word | | | | | | | | | | | | | | | | Range |
|--------|---------------------|-----------------|-----------------|-----------------|-----------------|-----------------|-----------------|----------------|----------------|----------------|----------------|----------------|----------------|----------------|----------------|----------------|----------------|-------------|
| | | 2 ¹⁵ | 2 ¹⁴ | 2 ¹³ | 2 ¹² | 2 ¹¹ | 2 ¹⁰ | 2 ⁹ | 2 ⁸ | 2 ⁷ | 2 ⁶ | 2 ⁵ | 2 ⁴ | 2 ³ | 2 ² | 2 ¹ | 2 ⁰ | |
| 32767 | ≥ 118.515 | 0 | 1 | 1 | 1 | 1 | 1 | 1 | 1 | 1 | 1 | 1 | 1 | 1 | 1 | 1 | 1 | Overflow |
| 32511 | 117.589 | 0 | 1 | 1 | 1 | 1 | 1 | 1 | 0 | 1 | 1 | 1 | 1 | 1 | 1 | 1 | 1 | Over-range |
| 27649 | ≥ 100.004 | 0 | 1 | 1 | 0 | 1 | 1 | 0 | 0 | 0 | 0 | 0 | 0 | 0 | 0 | 0 | 1 | |
| 27648 | 100.000 | 0 | 1 | 1 | 0 | 1 | 1 | 0 | 0 | 0 | 0 | 0 | 0 | 0 | 0 | 0 | 0 | Rated range |
| 1 | 0.003617 | 0 | 0 | 0 | 0 | 0 | 0 | 0 | 0 | 0 | 0 | 0 | 0 | 0 | 0 | 0 | 1 | |
| 0 | 0.000 | 0 | 0 | 0 | 0 | 0 | 0 | 0 | 0 | 0 | 0 | 0 | 0 | 0 | 0 | 0 | 0 | |
| -1 | -0.003617 | 1 | 1 | 1 | 1 | 1 | 1 | 1 | 1 | 1 | 1 | 1 | 1 | 1 | 1 | 1 | 1 | Under-range |
| -4864 | - 17.593 | 1 | 1 | 1 | 0 | 1 | 1 | 0 | 1 | 0 | 0 | 0 | 0 | 0 | 0 | 0 | 0 | |
| -32768 | ≤ - 17.596 | 1 | 0 | 0 | 0 | 0 | 0 | 0 | 0 | 0 | 0 | 0 | 0 | 0 | 0 | 0 | 0 | Under-flow |

Table 5-8 Life-Zero Input Ranges

| Units | Measured Value in % | Data Word | | | | | | | | | | | | | | | | Range |
|--|---------------------|-----------------|-----------------|-----------------|-----------------|-----------------|-----------------|----------------|----------------|----------------|----------------|----------------|----------------|----------------|----------------|----------------|----------------|-----------|
| | | 2 ¹⁵ | 2 ¹⁴ | 2 ¹³ | 2 ¹² | 2 ¹¹ | 2 ¹⁰ | 2 ⁹ | 2 ⁸ | 2 ⁷ | 2 ⁶ | 2 ⁵ | 2 ⁴ | 2 ³ | 2 ² | 2 ¹ | 2 ⁰ | |
| ≥ 32767 | ≥ 118.515 | 0 | 1 | 1 | 1 | 1 | 1 | 1 | 1 | 1 | 1 | 1 | 1 | 1 | 1 | 1 | 1 | Over-flow |
| 32511 | 117.589 | 0 | 1 | 1 | 1 | 1 | 1 | 1 | 0 | 1 | 1 | 1 | 1 | 1 | 1 | 1 | Over-range | |
| 27649 | ≥ 100.004 | 0 | 1 | 1 | 0 | 1 | 1 | 0 | 0 | 0 | 0 | 0 | 0 | 0 | 0 | 1 | | |
| 27648 | 100.000 | 0 | 1 | 1 | 0 | 1 | 1 | 0 | 0 | 0 | 0 | 0 | 0 | 0 | 0 | 0 | Rated range | |
| 1 | 0.003617 | 0 | 0 | 0 | 0 | 0 | 0 | 0 | 0 | 0 | 0 | 0 | 0 | 0 | 0 | 1 | | |
| 0 | 0.000 | 0 | 0 | 0 | 0 | 0 | 0 | 0 | 0 | 0 | 0 | 0 | 0 | 0 | 0 | 0 | | |
| -1 | -0.003617 | 1 | 1 | 1 | 1 | 1 | 1 | 1 | 1 | 1 | 1 | 1 | 1 | 1 | 1 | 1 | Under-range | |
| -4864 | -17.593 | 1 | 1 | 1 | 0 | 1 | 1 | 0 | 1 | 0 | 0 | 0 | 0 | 0 | 0 | 0 | | |
| In the event of wire break, the module reports 7FFF _H | | | | | | | | | | | | | | | | | | |

Analog Value Representation in Voltage Measuring Ranges

Table 5-9 Analog Value Representation in Voltage Measuring Ranges ± 10 V to ± 1 V

| System | Voltage Measuring Range | | | | | | |
|------------|-------------------------|------|------------|-----------|-----------|-----------|-------------|
| | Dec. | Hex. | ± 10 V | ± 5 V | ± 2.5 V | ± 1 V | |
| 118.515% | 32767 | 7FFF | 11.851 V | 5.926 V | 2.963 V | 1.185 V | Overflow |
| 117.593% | 32512 | 7F00 | | | | | |
| 117.589% | 32511 | 7EFF | 11.759 V | 5.879 V | 2.940 V | 1.176 V | Overrange |
| | 27649 | 6C01 | | | | | |
| 100.000% | 27648 | 6C00 | 10 V | 5 V | 2.5 V | 1 V | Rated range |
| 75.000% | 20736 | 5100 | 7.5 V | 3.75 V | 1.875 V | 0.75 V | |
| 0.003617% | 1 | 1 | 361.7 μV | 180.8 μV | 90.4 μV | 36.17 μV | |
| 0% | 0 | 0 | 0 V | 0 V | 0 V | 0 V | |
| | -1 | FFFF | | | | | |
| - 75.00% | - 20736 | AF00 | - 7.5 V | - 3.75 V | - 1.875 V | - 0.75 V | |
| - 100.000% | -27648 | 9400 | - 10 V | - 5 V | - 2.5 V | - 1 V | |
| | -27649 | 93FF | | | | | Underrange |
| -117.593% | -32512 | 8100 | - 11.759 V | - 5.879 V | - 2.940 V | - 1.176 V | |
| - 117.596% | - 32513 | 80FF | | | | | Underflow |
| - 118.519% | -32768 | 8000 | - 11.851 V | - 5.926 V | - 2.963 V | - 1.185 V | |

Table 5-10 Analog Value Representation in the Voltage Measuring Ranges ± 500 mV to ± 25 mV

| System | | | Voltage Measuring Range | | | | | |
|-----------|--------|------|-------------------------|--------------|--------------|--------------|-------------|-------------|
| | Dec. | Hex. | ± 500 mV | ± 250 mV | ± 80 mV | ± 50 mV | ± 25 mV | |
| 118.515% | 32767 | 7FFF | 592.6 mV | 296.3 mV | 94.8 mV | 59.3 mV | 29.6 mV | Overflow |
| 117.593% | 32512 | 7F00 | | | | | | |
| 117.589% | 32511 | 7EFF | 587.9 mV | 294.0 mV | 94.1 mV | 58.8 mV | 29.4 mV | Overrange |
| | 27649 | 6C01 | | | | | | |
| 100.000% | 27648 | 6C00 | 500 mV | 250 mV | 80 mV | 50 mV | 25 mV | Rated range |
| 75% | 20736 | 5100 | 375 mV | 187.54 mV | 60 mV | 37.5 mV | 18.75 mV | |
| 0.003617% | 1 | 1 | 18.08 μ V | 9.04 μ V | 2.89 μ V | 1.81 μ V | 904.2 nV | |
| 0% | 0 | 0 | 0 mV | 0 mV | 0 mV | 0 mV | 0 mV | |
| | -1 | FFFF | | | | | | |
| -75.00% | -20736 | AF00 | -375 mV | -187.54 mV | -60 mV | -37.5 mV | -18.75 mV | |
| -100.000% | -27648 | 9400 | -500 mV | -250 mV | -80 mV | -50 mV | -25 mV | |
| | -27649 | 93FF | | | | | | Underrange |
| -117.593% | -32512 | 8100 | -587.9 mV | -294.0 mV | -94.1 mV | -58.8 mV | -29.4 mV | |
| -117.596% | -32513 | 80FF | | | | | | Underflow |
| -118.519% | -32768 | 8000 | -592.6 mV | -296.3 mV | -94.8 mV | -59.3 mV | -29.6 mV | |

Table 5-11 Analog Value Representation in the Voltage Measuring Ranges 1 to 5 V and 0 to 10 V

| System | | | Voltage Measuring Range | | |
|------------------|--------|------|-------------------------|------------------------------|-------------|
| | Dec. | Hex. | 1 to 5 V | 0 to 10 V | |
| 118.515% | 32767 | 7FFF | 5.741 V | 11.852 V | Overflow |
| 117.593% | 32512 | 7F00 | | | |
| 117.589% | 32511 | 7EFF | 5.704 V | 11.759 V | Overrange |
| | 27649 | 6C01 | | | |
| 100.000% | 27648 | 6C00 | 5 V | 10 V | Rated range |
| 75% | 20736 | 5100 | 3.75 V | 7.5 V | |
| 0.003617% | 1 | 1 | 1 V + 144.7 μ V | 0 V + 361.7 μ V | |
| 0% | 0 | 0 | 1 V | 0 V | |
| | -1 | FFFF | | | |
| -17.593% | -4864 | ED00 | 0.296 V | Negative values not possible | Underrange |
| | -4865 | ECFF | | | |
| $\leq -17.596\%$ | -32768 | 8000 | | | |

Analog Value Representation in Current Measuring Ranges

Table 5-12 Analog Value Representation in the Current Measuring Ranges ± 20 mA to ± 3.2 mA

| System | | | Current Measuring Range | | | | |
|-----------|--------|------|-------------------------|-------------|------------|--------------|-------------|
| | Dec. | Hex. | ± 20 mA | ± 10 mA | ± 5 mA | ± 3.2 mA | |
| 118.515% | 32767 | 7FFF | 23.70 mA | 11.85 mA | 5.93 mA | 3.79 mA | Overflow |
| 117.593% | 32512 | 7F00 | | | | | |
| 117.589% | 32511 | 7EFF | 23.52 mA | 11.76 mA | 5.88 mA | 3.76 mA | Overrange |
| | 27649 | 6C01 | | | | | |
| 100.000% | 27648 | 6C00 | 20 mA | 10 mA | 5 mA | 3.2 mA | Rated range |
| 75% | 20736 | 5100 | 15 mA | 7.5 mA | 3.75 mA | 2.4 mA | |
| 0.003617% | 1 | 1 | 723.4 nA | 361.7 nA | 180.8 nA | 115.7 nA | |
| 0% | 0 | 0 | 0 mA | 0 mA | 0 mA | 0 mA | |
| | -1 | FFFF | | | | | |
| -75% | -20736 | AF00 | -15 mA | -7.5 mA | -3.75 mA | -2.4 mA | |
| -100.000% | -27648 | 9400 | -20 mA | -10 mA | -5 mA | -3.2 mA | |
| | -27649 | 93FF | | | | | Underrange |
| -117.593% | -32512 | 8100 | -23.52 mA | -11.76 mA | -5.88 mA | -3.76 mA | |
| -117.596% | -32513 | 80FF | | | | | Underflow |
| -118.519% | -32768 | 8000 | -23.70 mA | -11.85 mA | -5.93 mA | -3.79 mA | |

Table 5-13 Analog Value Representation in Current Measuring Ranges 0 to 20 mA

| System | | | Current Measuring Range | | |
|------------------|----------|-------|-------------------------|-------------|------------|
| | Dec. | Hex. | 0 to 20 mA | | |
| 118.515% | 32767 | 7FFF | 23.70 mA | Overflow | |
| 117.593% | 32512 | 7F00 | | | |
| 117.589% | 32511 | 7EFF | 23.52 mA | Overrange | |
| | 27649 | 6C01 | | | |
| 100.000% | 27648 | 6C00 | 20 mA | Rated range | |
| 75% | 20736 | 5100 | 15 mA | | |
| 0.003617% | 1 | 1 | 723.4 nA | | |
| 0% | 0 | 0 | 0 mA | | |
| | -1 | FFFF | | | |
| | -17.593% | -4864 | ED00 | -3.52 mA | Underrange |
| | -4865 | ECFF | | | |
| $\leq -17.596\%$ | -32768 | 8000 | | Underflow | |

Table 5-14 Analog Value Representation in Current Measuring Ranges 4 to 20 mA

| System | | | Current Measuring Range | |
|-------------|---------|------|-------------------------|-------------|
| | Dec. | Hex. | 4 to 20 mA | |
| 118.515% | 32767 | 7FFF | 22.96 mA | Overflow |
| 117.593% | 32512 | 7F00 | | |
| 117.589% | 32511 | 7EFF | 22.81 mA | Overrange |
| | 27649 | 6C01 | | |
| 100.000% | 27648 | 6C00 | 20 mA | Rated range |
| 75% | 20736 | 5100 | 16 mA | |
| 0.003617% | 1 | 1 | 4 mA + 578.7 nA | |
| 0% | 0 | 0 | 4 mA | |
| | - 1 | FFFF | | Underrange |
| - 17.593% | - 4864 | ED00 | 1.185 mA | |
| | | | | Underflow |
| ≤ - 17.596% | - 32767 | 7FFF | | |

Analog Value Representation for Resistance-Type Sensors

Table 5-15 Analog Value Representation for Resistance-Type Sensors from 48 Ω to 6 kΩ

| System | | | Resistance-Type Sensor Range | | | | | |
|-----------|-------|------|---|----------|----------|----------|---------|-------------|
| | Dec. | Hex. | 48 Ω | 150 Ω | 300 Ω | 600 Ω | 6 kΩ | |
| 118.515% | 32767 | 7FFF | 56.89 Ω | 177.77 Ω | 355.54 Ω | 711.09 Ω | 7.11 kΩ | Overflow |
| 117.593% | 32512 | 7F00 | | | | | | |
| 117.589% | 32511 | 7EFF | 56.44Ω | 176.38 | 352.77 Ω | 705.53 Ω | 7.06 kΩ | Overrange |
| | 27649 | 6C01 | | | | | | |
| 100.000% | 27648 | 6C00 | 48 Ω | 150 Ω | 300 Ω | 600 Ω | 6 kΩ | Rated range |
| 75% | 20736 | 5100 | 36 Ω | 112.5 Ω | 225Ω | 450 Ω | 4.5 kΩ | |
| 0.003617% | 1 | 1 | 1.74mΩ | 5.43mΩ | 10.85mΩ | 21.70mΩ | 217.0mΩ | |
| 0% | 0 | 0 | 0 Ω | 0 Ω | 0 Ω | 0 Ω | 0 Ω | |
| | | | (negative values physically not possible) | | | | | Underrange |
| | | | | | | | | |

Analog Value Representation for Resistance Thermometers Pt x00 Standard

Table 5-16 Analog Value Representation for Resistance Thermometers Pt 100, 200, 500,1000

| Pt x00 Standard in °C (1 Digit = 0.1°C) | Units | | Pt x00 Standard in °F (1 Digit = 0.1 °F) | Units | | Pt x00 Standard in K (1 Digit = 0.1 K) | Units | | Range |
|--|---------|-------------------|---|---------|-------------------|---|---------|-------------------|-------------|
| | Decimal | Hexadecimal | | Decimal | Hexadecimal | | Decimal | Hexadecimal | |
| > 1000.0 | 32767 | 7FFF _H | > 1832.0 | 32767 | 7FFF _H | > 1273.2 | 32767 | 7FFF _H | Overflow |
| 1000.0 | 10000 | 2710 _H | 1832.0 | 18320 | 4790 _H | 1273.2 | 12732 | 31BC _H | Ovrange |
| : | : | : | : | : | : | : | : | : | |
| 850.1 | 8501 | 2135 _H | 1562.1 | 15621 | 3D05 _H | 1123.3 | 11233 | 2BE1 _H | |
| 850.0 | 8500 | 2134 _H | 1562.0 | 15620 | 3D04 _H | 1123.2 | 11232 | 2BE0 _H | Rated range |
| : | : | : | : | : | : | : | : | : | |
| -200.0 | -2000 | F830 _H | -328.0 | -3280 | F330 _H | 73.2 | 732 | 2DC _H | |
| -200.1 | -2001 | F82F _H | -328.1 | -3281 | F32F _H | 73.1 | 731 | 2DB _H | Underrange |
| : | : | : | : | : | : | : | : | : | |
| -243.0 | -2430 | F682 _H | -405.4 | -4054 | F02A _H | 30.2 | 302 | 12E _H | |
| < -243.0 | -32768 | 8000 _H | < -405.4 | -32768 | 8000 _H | < 30.2 | 32768 | 8000 _H | Underflow |

Analog Value Representation for Resistance Thermometers Pt x00 Climatic

Table 5-17 Analog Value Representation for Resistance Thermometers Pt 100, 200, 500,1000

| Pt x00 Climatic in °C (1 Digit = 0.01°C) | Units | | Pt x00 Climatic in °F (1 Digit = 0.01 °F) | Units | | Range |
|---|---------|-------------------|--|---------|-------------------|-------------|
| | Decimal | Hexadecimal | | Decimal | Hexadecimal | |
| > 155.00 | 32767 | 7FFF _H | > 311.00 | 32767 | 7FFF _H | Overflow |
| 155.00 | 15500 | 3C8C _H | 311.00 | 31100 | 797C _H | Ovrange |
| : | : | : | : | : | : | |
| 130.01 | 13001 | 32C9 _H | 266.01 | 26601 | 67E9 _H | |
| 130.00 | 13000 | 32C8 _H | 266.00 | 26600 | 67E8 _H | Rated range |
| : | : | : | : | : | : | |
| -120.00 | -12000 | D120 _H | -184.00 | -18400 | B820 _H | |
| -120.01 | -12001 | D11F _H | -184.01 | -18401 | B81F _H | Underrange |
| : | : | : | : | : | : | |
| -145.00 | -14500 | C75C _H | -229.00 | -22900 | A68C _H | |
| < -145.00 | -32768 | 8000 _H | < -229.00 | -32768 | 8000 _H | Underflow |

Analog Value Representation for Resistance Thermometers Ni x00 Standard

Table 5-18 Analog Value Representation for Resistance Thermometers Ni100, 120, 200, 500, 1000

| Ni x00 Standard in °C (1 Digit = 0.1°C) | Units | | Ni x00 Standard in °F (1 Digit = 0.1 °F) | Units | | Ni x00 Standard in K (1 Digit = 0.1 K) | Units | | Range |
|--|---------|-------------------|---|---------|-------------------|---|---------|-------------------|-------------|
| | Decimal | Hexadecimal | | Decimal | Hexadecimal | | Decimal | Hexadecimal | |
| > 295.0 | 32767 | 7FFF _H | > 563.0 | 32767 | 7FFF _H | > 568.2 | 32767 | 7FFF _H | Overflow |
| 295.0 | 2950 | B86 _H | 563.0 | 5630 | 15FE _H | 568.2 | 5682 | 1632 _H | Overrange |
| : | : | : | : | : | : | : | : | : | |
| 250.1 | 2501 | 9C5 _H | 482.1 | 4821 | 12D5 _H | 523.3 | 5233 | 1471 _H | Rated range |
| 250.0 | 2500 | 9C4 _H | 482.0 | 4820 | 12D4 _H | 523.2 | 5232 | 1470 _H | |
| : | : | : | : | : | : | : | : | : | Underrange |
| -60.0 | -600 | FDA8 _H | -76.0 | -760 | FD08 _H | 213.2 | 2132 | 854 _H | |
| -60.1 | -601 | FDA7 _H | -76.1 | -761 | FD07 _H | 213.1 | 2131 | 853 _H | Underflow |
| : | : | : | : | : | : | : | : | : | |
| -105.0 | -1050 | FBE6 _H | -157.0 | -1570 | F9DE _H | 168.2 | 1682 | 692 _H | |
| < -105.0 | -32768 | 8000 _H | < -157.0 | -32768 | 8000 _H | < 168.2 | 32768 | 8000 _H | |

Analog Value Representation for Resistance Thermometers Ni x00 Climatic

Table 5-19 Analog Value Representation for Resistance Thermometers Ni 100, 120, 200, 500, 1000

| Ni x00 Climatic in °C (1 Digit = 0.01°C) | Units | | Ni x00 Climatic in °F (1 Digit = 0.01 °F) | Units | | Range |
|---|---------|-------------------|--|---------|-------------------|-------------|
| | Decimal | Hexadecimal | | Decimal | Hexadecimal | |
| > 295.00 | 32767 | 7FFF _H | > 325.11 | 32767 | 7FFF _H | Overflow |
| 295.00 | 29500 | 733C _H | 327.66 | 32766 | 7FFE _H | Overrange |
| : | : | : | : | : | : | |
| 250.01 | 25001 | 61A9 _H | 280.01 | 28001 | 6D61 _H | Rated range |
| 250.00 | 25000 | 61A8 _H | 280.00 | 28000 | 6D60 _H | |
| : | : | : | : | : | : | Underrange |
| -60.00 | -6000 | E890 _H | -76.00 | -7600 | E250 _H | |
| -60.01 | -6001 | E88F _H | -76.01 | -7601 | E24F _H | Underflow |
| : | : | : | : | : | : | |
| -105.00 | -10500 | D6FC _H | -157.00 | -15700 | C2AC _H | |
| < -105.00 | -32768 | 8000 _H | < -157.00 | -32768 | 8000 _H | |

Analog Value Representation for Resistance Thermometers Cu 10 Standard

Table 5-20 Analog Value Representation for Resistance Thermometers Cu 10

| Cu 10 Standard in °C (1 Digit = 0.01°C) | Units | | Cu 10 Standard in °F (1 Digit = 0.01 °F) | Units | | Cu 10 Standard in K (1 Digit = 0.01 K) | Units | | Range |
|--|---------|-------------------|---|---------|-------------------|---|---------|-------------------|-------------|
| | Decimal | Hexadecimal | | Decimal | Hexadecimal | | Decimal | Hexadecimal | |
| > 312.0 | 32767 | 7FFF _H | > 593.6 | 32767 | 7FFF _H | > 585.2 | 32767 | 7FFF _H | Overflow |
| 312.0 | 3120 | C30 _H | 593.6 | 5936 | 1730 _H | 585.2 | 5852 | 16DC _H | Overrange |
| : | : | : | : | : | : | : | : | : | |
| 260.1 | 2601 | A29 _H | 500.1 | 5001 | 12D5 _H | 533.3 | 5333 | 14D5 _H | |
| 260.0 | 2600 | A28 _H | 500.0 | 5000 | 1389 _H | 533.2 | 5332 | 14D4 _H | Rated range |
| : | : | : | : | : | : | : | : | : | |
| -200.0 | -2000 | F830 _H | -328.0 | -3280 | F330 _H | 73.2 | 732 | 2DC _H | |
| -200.1 | -2001 | F82F _H | -328.1 | -3281 | F32F _H | 73.1 | 731 | 2DB _H | Underrange |
| : | : | : | : | : | : | : | : | : | |
| -240.0 | -2400 | F6A0 _H | -400.0 | -4000 | F060 _H | 33.2 | 332 | 14C _H | |
| < -240.0 | -32768 | 8000 _H | < -400.0 | -32768 | 8000 _H | < 33.2 | 32768 | 8000 _H | Underflow |

Analog Value Representation for Resistance Thermometers Cu 10 Climatic

Table 5-21 Analog Value Representation for Resistance Thermometers Cu 10

| Cu 10 Climatic in °C (1 Digit = 0.01°C) | Units | | Cu 10 Climatic in °F (1 Digit = 0.01 °F) | Units | | Range |
|--|---------|-------------------|---|---------|--------------------|-------------|
| | Decimal | Hexadecimal | | Decimal | Hexadecimal | |
| > 180.00 | 32767 | 7FFF _H | > 325.11 | 32767 | 7FFF _H | Overflow |
| 180.00 | 18000 | 4650 _H | 327.66 | 32766 | 7FFE _H | Overrange |
| : | : | : | : | : | : | |
| 150.01 | 15001 | 3A99 _H | 280.01 | 28001 | 6D61A _H | |
| 150.00 | 15000 | 3A98 _H | 280.00 | 28000 | 6D60 _H | Rated range |
| : | : | : | : | : | : | |
| -50.00 | -5000 | EC78 _H | -58.00 | -5800 | E958 _H | |
| -50.01 | -5001 | EC77 _H | -58.01 | -5801 | E957 _H | Underrange |
| : | : | : | : | : | : | |
| -60.00 | -6000 | E890 _H | -76.00 | -7600 | E250 _H | |
| < -60.00 | -32768 | 8000 _H | < -76.00 | -32768 | 8000 _H | Underflow |

Analog Value Representation for Thermocouple Type B

Table 5-22 Analog Value Representation for Thermocouple Type B

| Type B in °C | Units | | Type B in °F | Units | | Type B in K | Units | | Range |
|-----------------|--------------|-----------------------|-----------------|--------------|-----------------------|----------------|--------------|-----------------------|-------------|
| | Deci- mal | Hexa- deci- mal | | Deci- mal | Hexa- deci- mal | | Deci- mal | Hexa- deci- mal | |
| > 2070.0 | 32767 | 7FFF _H | > 3276.6 | 32767 | 7FFF _H | > 2343.2 | 32767 | 7FFF _H | Overflow |
| 2070.0 | 20700 | 50DC _H | 3276.6 | 32766 | 7FFE _H | 2343.2 | 23432 | 5B88 _H | Overrange |
| : | : | : | : | : | : | : | : | : | |
| 1821.0 | 18210 | 4722 _H | 2786.6 | 27866 | 6CDA _H | 2094.2 | 20942 | 51CE _H | |
| 1820.0 | 18200 | 4718 _H | 2786.5 | 27865 | 6CD9 _H | 2093.2 | 20932 | 51C4 _H | Rated range |
| : | : | : | : | : | : | : | : | : | |
| 0,0 | 0 | 0000 _H | -32.0 | -320 | FEC0 _H | 273.2 | 2732 | 0AAC _H | |
| : | : | : | : | : | : | : | : | : | Underrange |
| -120.0 | -1200 | FB50 _H | -184.0 | -1840 | F8D0 _H | 153.2 | 1532 | 05FC _H | |
| < -120.0 | -32768 | 8000 _H | < -184.0 | -32768 | 8000 _H | < 153.2 | 32768 | 8000 _H | Underflow |

Analog Value Representation for Thermocouple Type E

Table 5-23 Analog Value Representation for Thermocouple Type E

| Type E in °C | Units | | Type E in °F | Units | | Type E in K | Units | | Range |
|--|--------------|-----------------------|---|--------------|-----------------------|---|--------------|-----------------------|-------------|
| | Deci- mal | Hexa- deci- mal | | Deci- mal | Hexa- deci- mal | | Deci- mal | Hexa- deci- mal | |
| > 1200.0 | 32767 | 7FFF _H | > 2192,0 | 32767 | 7FFF _H | > 1473.2 | 32767 | 7FFF _H | Overflow |
| 1200.0 | 12000 | 2EE0 _H | 2192.0 | 21920 | 55A0 _H | 1473.2 | 14732 | 398C _H | Overrange |
| : | : | : | : | : | : | : | : | : | |
| 1000.1 | 10001 | 2711 _H | 1833.8 | 18338 | 47A2 _H | 1274.2 | 12742 | 31C6 _H | |
| 1000.0 | 10000 | 2710 _H | 1832.0 | 18320 | 4790 _H | 1273.2 | 12732 | 31BC _H | Rated range |
| : | : | : | : | : | : | : | : | : | |
| -270.0 | -2700 | F574 _H | -454.0 | -4540 | EE44 _H | 0 | 0 | 0000 _H | |
| < -270.0 | < -2700 | < F574 _H | < -454.0 | < -4540 | < EE44 _H | < 0 | < 0 | < 0000 _H | Underflow |
| In the case of incorrect wiring (for example, polarity reversal or open inputs) or of a sensor error in the negative range (for example, incorrect thermocouple type), the analog input module reports an underflow... | | | | | | | | | |
| ...if F0C4 _H is violated and outputs 8000 _H | | | ...if FB70 _H is violated and outputs 8000 _H | | | ...if E5D4 _H is violated and outputs 8000 _H | | | |

Analog Value Representation for Thermocouple Type J

Table 5-24 Analog Value Representation for Thermocouple Type J

| Type J in °C | Units | | Type J in °F | Units | | Type J in K | Units | | Range |
|---|--------------|--------------------|---|--------------|-----------------------|---|--------------|-----------------------|-------------|
| | Deci- mal | Hexade- cimal | | Deci- mal | Hexa- decim- al | | Deci- mal | Hexa- decim- al | |
| > 1450.0 | 32767 | 7FFF _H | > 2642.0 | 32767 | 7FFF _H | > 1723.2 | 32767 | 7FFF _H | Overflow |
| 1450.0 | 14500 | 38A4 _H | 2642.0 | 26420 | 6734 _H | 1723.2 | 17232 | 4350 _H | Overrange |
| : | : | : | : | : | : | : | : | : | |
| 1201.0 | 12010 | 2EEA _H | 2193.8 | 21938 | 55B2 _H | 1474.2 | 14742 | 3996 _H | |
| 1200.0 | 12000 | 2EE0 _H | 2192.0 | 21920 | 55A0 _H | 1473.2 | 14732 | 398C _H | Rated range |
| : | : | : | : | : | : | : | : | : | |
| -210.0 | -2100 | F7CC _H | -346.0 | -3460 | F27C _H | 63.2 | 632 | 0278 _H | |
| < -210.0 | < -2100 | <F7CC _H | < -346.0 | < -3460 | <F27C _H | < 63.2 | < 632 | < 0278 _H | Underflow |
| In the case of incorrect wiring (for example, polarity reversal or open inputs) or of a sensor error in the negative range (for example incorrect thermocouple type), the analog input module reports an underflow... | | | | | | | | | |
| ...if F31C _H is violated and outputs 8000 _H | | | ...if EA0C _H is violated and outputs 8000 _H | | | ...if FDC8 _H is violated and outputs 8000 _H | | | |

Analog Value Representation for Thermocouple Type K

Table 5-25 Analog Value Representation for Thermocouple Type K

| Type K in °C | Units | | Type K in °F | Units | | Type K in K | Units | | Range |
|--|--------------|---------------------|---|--------------|-----------------------|---|--------------|-----------------------|-------------|
| | Deci- mal | Hexade- cimal | | Deci- mal | Hexa- decim- al | | Deci- mal | Hexa- decim- al | |
| > 1622.0 | 32767 | 7FFF _H | > 2951.6 | 32767 | 7FFF _H | > 1895.2 | 32767 | 7FFF _H | Overflow |
| 1622.0 | 16220 | 3F5C _H | 2951.6 | 29516 | 734C _H | 1895.2 | 18952 | 4A08 _H | Overrange |
| : | : | : | : | : | : | : | : | : | |
| 1373.0 | 13730 | 35A2 _H | 2503.4 | 25034 | 61CA _H | 1646.2 | 16462 | 404E _H | |
| 1372.0 | 13720 | 3598 _H | 2501.6 | 25061 | 61B8 _H | 1645.2 | 16452 | 4044 _H | Rated range |
| : | : | : | : | : | : | : | : | : | |
| -270.0 | -2700 | F574 _H | -454.0 | -4540 | EE44 _H | 0 | 0 | 0000 _H | |
| < -270.0 | < -2700 | < F574 _H | < -454.0 | < -4540 | <EE44 _H | < 0 | < 0 | < 0000 _H | Underflow |
| In the case of incorrect wiring (for example, polarity reversal or open inputs) or of a sensor error in the negative range (for example, incorrect thermocouple type), the analog input module reports an underflow... | | | | | | | | | |
| ...if F0C4 _H is violated and outputs 8000 _H | | | ...if E5D4 _H is violated and outputs 8000 _H | | | ...if FB70 _H is violated and outputs 8000 _H | | | |

Analog Value Representation for Thermocouple Type L

Table 5-26 Analog Value Representation for Thermocouple Type L

| Type L in °C | Units | | Type L in °F | Units | | Type L in K | Units | | Range |
|--|--------------------|---|---|---------------------|---|---|---------------------|---|-------------|
| | Decimal | Hexa- decimal | | Deci- mal | Hexa- decim- al | | Deci- mal | Hexa- decimal | |
| > 1150.0 | 32767 | 7FFF _H | > 2102.0 | 32767 | 7FFF _H | > 1423.2 | 32767 | 7FFF _H | Overflow |
| 1150.0 : 901.0 | 11500 : 9010 | 2CEC _H : 2332 _H | 2102.0 : 1653.8 | 21020 : 16538 | 521C _H : 409A _H | 1423.2 : 1174.2 | 14232 : 11742 | 3798 _H : 2DDE _H | Overrange |
| 900.0 : -200.0 | 9000 : -2000 | 2328 _H : F830 _H | 1652.0 : -328.0 | 16520 : -3280 | 4088 _H : F330 _H | 1173.2 : 73.2 | 11732 : 732 | 2DD4 _H : 02DC _H | Rated range |
| < -200.0 | < -2000 | < F830 _H | < -328.0 | < -3280 | < F330 _H | < 73.2 | < 732 | < 02DC _H | Underflow |
| In the case of incorrect wiring (for example, polarity reversal or open inputs) or of a sensor error in the negative range (for example, incorrect thermocouple type), the analog input module reports an underflow... | | | | | | | | | |
| ...if F380 _H is violated and outputs 8000 _H | | | ...if EAC0 _H is violated and outputs 8000 _H | | | ...if FE2C _H is violated and outputs 8000 _H | | | |

Analog Value Representation for Thermocouple Type N

Table 5-27 Analog Value Representation for Thermocouple Type N

| Type N in °C | Units | | Type N in °F | Units | | Type N in K | Units | | Range |
|--|---------------------|---|---|---------------------|---|---|---------------------|---|-------------|
| | Deci- mal | Hexa- decim- al | | Deci- mal | Hexa- decim- al | | Deci- mal | Hexa- decim- al | |
| > 1550.0 | 32767 | 7FFF _H | > 2822.0 | 32767 | 7FFF _H | > 1823.2 | 32767 | 7FFF _H | Overflow |
| 1550.0 : 1300.1 | 15500 : 13001 | 3C8C _H : 32C9 _H | 2822.0 : 2373.8 | 28220 : 23738 | 6E3C _H : 5CBA _H | 1823.2 : 1574.2 | 18232 : 15742 | 4738 _H : 3D7E _H | Overrange |
| 1300.0 : -270.0 | 13000 : -2700 | 32C8 _H : F574 _H | 2372.0 : -454.0 | 23720 : -4540 | 5CA8 _H : EE44 _H | 1573.2 : 0 | 15732 : 0 | 3D74 _H : 0000 _H | Rated range |
| < -270.0 | < -2700 | < F574 _H | < -454.0 | < -4540 | < EE44 _H | < 0 | < 0 | < 0000 _H | Underflow |
| In the case of incorrect wiring (for example, polarity reversal or open inputs) or of a sensor error in the negative range (for example, incorrect thermocouple type), the analog input module reports an underflow... | | | | | | | | | |
| ...if F0C4 _H is violated and outputs 8000 _H | | | ...if E5D4 _H is violated and outputs 8000 _H | | | ...if FB70 _H is violated and outputs 8000 _H | | | |

Analog Value Representation for Thermocouple Types R, S

Table 5-28 Analog Value Representation for Thermocouple Types R, S

| Types R, S in °C | Units | | Types R, S in °F | Units | | Types R, S in K | Units | | Range |
|---------------------|--------------|-----------------------|------------------------|--------------|-----------------------|-----------------------|--------------|-----------------------|-------------|
| | Deci- mal | Hexa- deci- mal | | Deci- mal | Hexa- deci- mal | | Deci- mal | Hexa- deci- mal | |
| > 2019.0 | 32767 | 7FFF _H | > 3276.6 | 32767 | 7FFF _H | > 2292.2 | 32767 | 7FFF _H | Overflow |
| 2019.0 | 20190 | 4EDE _H | 3276.6 | 32766 | 7FFE _H | 2292.2 | 22922 | 598A _H | Overrange |
| : | : | : | : | : | : | : | : | : | |
| 1770.0 | 17770 | 4524 _H | 3218.0 | 32180 | 7DB4 _H | 2043.2 | 20432 | 4FD0 _H | |
| 1769.0 | 17690 | 451A _H | 3216.2 | 32162 | 7DA2 _H | 2042.2 | 20422 | 4FC6 _H | Rated range |
| : | : | : | : | : | : | : | : | : | |
| -50.0 | -500 | FE0C _H | -58.0 | -580 | FDBC _H | 223.2 | 2232 | 08B8 _H | |
| -51.0 | -510 | FE02 _H | -59.8 | -598 | FDA A _H | 222.2 | 2222 | 08AE _H | Underrange |
| : | : | : | : | : | : | : | : | : | |
| -170.0 | -1700 | F95C _H | -274.0 | -2740 | F54C _H | 103.2 | 1032 | 0408 _H | |
| < -170.0 | -32768 | 8000 _H | < -274.0 | -32768 | 8000 _H | < 103.2 | < 1032 | 8000 _H | Underflow |

Analog Value Representation for Thermocouple Type T

Table 5-29 Analog Value Representation for Thermocouple Type T

| Type T in °C | Units | | Type T in °F | Units | | Type T in K | Units | | Range |
|--|--------------|-----------------------|---|--------------|-----------------------|---|--------------|-----------------------|-------------|
| | Deci- mal | Hexa- deci- mal | | Deci- mal | Hexa- deci- mal | | Deci- mal | Hexa- deci- mal | |
| > 540.0 | 32767 | 7FFF _H | > 1004.0 | 32767 | 7FFF _H | > 813.2 | 32767 | 7FFF _H | Overflow |
| 540.0 | 5400 | 1518 _H | 1004.0 | 10040 | 2738 _H | 813.2 | 8132 | 1FC4 _H | Overrange |
| : | : | : | : | : | : | : | : | : | |
| 401.0 | 4010 | 0FAA _H | | | | | | | |
| 400.0 | 4000 | 0FA0 _H | 752.0 | 7520 | 1D60 _H | 673.2 | 6732 | 1AAC _H | Rated range |
| : | : | : | : | : | : | : | : | : | |
| -270.0 | -2700 | F574 _H | -454.0 | -4540 | EE44 _H | 3.2 | 32 | 0020 _H | |
| < -270.0 | < -2700 | H | < -454.0 | < -4540 | < EE44 _H | < 3.2 | < 32 | < 0020 _H | Underflow |
| In the case of incorrect wiring (for example, polarity reversal or open inputs) or of a sensor error in the negative range (for example, incorrect thermocouple type), the analog input module reports an underflow... | | | | | | | | | |
| ...if F0C4 _H is violated and outputs 8000 _H | | | ...if E5D4 _H is violated and outputs 8000 _H | | | ...if FB70 _H is violated and outputs 8000 _H | | | |

Analog Value Representation for Thermocouple Type U

Table 5-30 Analog Value Representation for Thermocouple Type U

| Type U in °C | Units | | Type U in °F | Units | | Type U in K | Units | | Range |
|--|----------------------|---|---|---------------------|---|---|--------------------|---|-------------|
| | Deci- mal | Hexa- deci- mal | | Deci- mal | Hexa- deci- mal | | Deci- mal | Hexa- decimal | |
| > 850.0 | 32767 | 7FFF _H | > 1562.0 | 32767 | 7FFF _H | > 1123.2 | 32767 | 7FFF _H | Overflow |
| 850.0 : 601.0 | 8500 : 6010 | 2134 _H : 177A _H | 1562.0 : 1113.8 | 15620 : 11138 | 2738.0 H : 2B82 _H | 1123.2 : 874.2 | 11232 : 8742 | 2BE0 _H : 2226 _H | Overrange |
| 600.0 : -200.0 | 6000 W : -2000 | 1770 _H : F830 _H | 1112.0 : -328.0 | 11120 : -3280 | 2B70 _H : F330 _H | 873.2 : 73.2 | 8732 : 732 | 221C _H : 02DC _H | Rated range |
| < -200.0 | < -2000 | H | < -328.0 | < -3280 | H | < 73.2 | < 732 | <02DC _H | Underflow |
| In the case of incorrect wiring (for example, polarity reversal or open inputs) or of a sensor error in the negative range (for example, incorrect thermocouple type), the analog input module reports an underflow... | | | | | | | | | |
| ...if F380 _H is violated and outputs 8000 _H | | | ...if EAC0 _H is violated and outputs 8000 _H | | | ...if FE2C _H is violated and outputs 8000 _H | | | |

5.3.2 Analog Value Representation for Analog Output Channels

Introduction

The tables in this chapter contain the analog value representation for output channels of the analog output modules. The values in the tables apply to all modules with the corresponding output ranges.

Notes on How to Read the Tables

Tables 5-31 to 5-33 contain the binary representation of the output values.

Since the binary representation of the output values is always the same, starting at 5-34 these tables only contain the output ranges and the units.

Binary Representation of the Output Ranges

The output ranges shown in Tables 5-31 to 5-33 are defined in two's complement representation:

Table 5-31 Bipolar Output Ranges

| Units | Output Value in % | Data Word | | | | | | | | | | | | | | | | Range |
|---------|-------------------|-----------------|-----------------|-----------------|-----------------|-----------------|-----------------|----------------|----------------|----------------|----------------|----------------|----------------|----------------|----------------|----------------|----------------|-------------|
| | | 2 ¹⁵ | 2 ¹⁴ | 2 ¹³ | 2 ¹² | 2 ¹¹ | 2 ¹⁰ | 2 ⁹ | 2 ⁸ | 2 ⁷ | 2 ⁶ | 2 ⁵ | 2 ⁴ | 2 ³ | 2 ² | 2 ¹ | 2 ⁰ | |
| ≥ 32512 | 0% | 0 | 1 | 1 | 1 | 1 | 1 | 1 | 1 | x | x | x | x | x | x | x | x | Overflow |
| 32511 | 117.589 | 0 | 1 | 1 | 1 | 1 | 1 | 1 | 0 | 1 | 1 | 1 | 1 | 1 | 1 | 1 | 1 | Overrange |
| 27649 | ≥ 100.004 | 0 | 1 | 1 | 0 | 1 | 1 | 0 | 0 | 0 | 0 | 0 | 0 | 0 | 0 | 0 | 1 | |
| 27648 | 100.000 | 0 | 1 | 1 | 0 | 1 | 1 | 0 | 0 | 0 | 0 | 0 | 0 | 0 | 0 | 0 | 0 | Rated range |
| 1 | 0.003617 | 0 | 0 | 0 | 0 | 0 | 0 | 0 | 0 | 0 | 0 | 0 | 0 | 0 | 0 | 0 | 1 | |
| 0 | 0.000 | 0 | 0 | 0 | 0 | 0 | 0 | 0 | 0 | 0 | 0 | 0 | 0 | 0 | 0 | 0 | 0 | |
| -1 | -0.003617 | 1 | 1 | 1 | 1 | 1 | 1 | 1 | 1 | 1 | 1 | 1 | 1 | 1 | 1 | 1 | 1 | |
| -27648 | -100.000 | 1 | 0 | 0 | 1 | 0 | 1 | 0 | 0 | 0 | 0 | 0 | 0 | 0 | 0 | 0 | 0 | Under range |
| -27649 | ≤ 100.004 | 1 | 0 | 0 | 1 | 0 | 0 | 1 | 1 | 1 | 1 | 1 | 1 | 1 | 1 | 1 | 1 | |
| -32512 | -117.593 | 1 | 0 | 0 | 0 | 0 | 0 | 0 | 1 | 0 | 0 | 0 | 0 | 0 | 0 | 0 | 0 | Underflow |
| ≤ 32513 | 0% | 1 | 0 | 0 | 0 | 0 | 0 | 0 | 0 | x | x | x | x | x | x | x | x | |

Table 5-32 Unipolar Output Ranges

| Units | Output Value in % | Data Word | | | | | | | | | | | | | | | Range | |
|---------|-------------------|----------------------------|----------------------------|----------------------------|----------------------------|-----------------------------|---------------|---------------|---------------|---------------|---------------|---------------|---------------|---------------|---------------|---------------|-------|---|
| | | ²¹ ₅ | ²¹ ₄ | ²¹ ₃ | ²¹ ₂ | ²¹¹ ₀ | ²⁹ | ²⁸ | ²⁷ | ²⁶ | ²⁵ | ²⁴ | ²³ | ²² | ²¹ | ²⁰ | | |
| ≥ 32512 | 0% | 0 | 1 | 1 | 1 | 1 | 1 | 1 | 1 | x | x | x | x | x | x | x | x | Overflow |
| 32511 | 117.589 | 0 | 1 | 1 | 1 | 1 | 1 | 1 | 0 | 1 | 1 | 1 | 1 | 1 | 1 | 1 | 1 | Overrange |
| 27649 | ≥ 100.004 | 0 | 1 | 1 | 0 | 1 | 1 | 0 | 0 | 0 | 0 | 0 | 0 | 0 | 0 | 0 | 1 | |
| 27648 | 100.000 | 0 | 1 | 1 | 0 | 1 | 1 | 0 | 0 | 0 | 0 | 0 | 0 | 0 | 0 | 0 | 0 | Rated range |
| 1 | 0.003617 | 0 | 0 | 0 | 0 | 0 | 0 | 0 | 0 | 0 | 0 | 0 | 0 | 0 | 0 | 0 | 1 | |
| 0 | 0.000 | 0 | 0 | 0 | 0 | 0 | 0 | 0 | 0 | 0 | 0 | 0 | 0 | 0 | 0 | 0 | 0 | |
| -1 | 0.000 | 1 | 1 | 1 | 1 | 1 | 1 | 1 | 1 | 1 | 1 | 1 | 1 | 1 | 1 | 1 | 1 | Limited to rated range lower limit of 0 V and 0 mA |
| -32512 | | 1 | 0 | 0 | 0 | 0 | 0 | 0 | 1 | 0 | 0 | 0 | 0 | 0 | 0 | 0 | 0 | |
| ≤ 32513 | 0% | 1 | 0 | 0 | 0 | 0 | 0 | 0 | 0 | x | x | x | x | x | x | x | x | Underflow |

Table 5-33 Life-Zero Output Ranges

| Units | Output Value in % | Data Word | | | | | | | | | | | | | | | | Range |
|----------|-------------------|----------------------------|----------------------------|----------------------------|----------------------------|----------------------------|----------------------------|---------------|---------------|---------------|---------------|---------------|---------------|---------------|---------------|---------------|--|-----------|
| | | ²¹ ₅ | ²¹ ₄ | ²¹ ₃ | ²¹ ₂ | ²¹ ₁ | ²¹ ₀ | ²⁹ | ²⁸ | ²⁷ | ²⁶ | ²⁵ | ²⁴ | ²³ | ²² | ²¹ | ²⁰ | |
| ≥ 32512 | 0 % | 0 | 1 | 1 | 1 | 1 | 1 | 1 | 1 | x | x | x | x | x | x | x | x | Over-flow |
| 32511 | 117.589 | 0 | 1 | 1 | 1 | 1 | 1 | 1 | 0 | 1 | 1 | 1 | 1 | 1 | 1 | 1 | Over-range | |
| 27649 | ≥ 100.004 | 0 | 1 | 1 | 0 | 1 | 1 | 0 | 0 | 0 | 0 | 0 | 0 | 0 | 0 | 1 | | |
| 27648 | 100.000 | 0 | 1 | 1 | 0 | 1 | 1 | 0 | 0 | 0 | 0 | 0 | 0 | 0 | 0 | 0 | Rated range | |
| 1 | 0.003617 | 0 | 0 | 0 | 0 | 0 | 0 | 0 | 0 | 0 | 0 | 0 | 0 | 0 | 0 | 1 | | |
| 0 | 0.000 | 0 | 0 | 0 | 0 | 0 | 0 | 0 | 0 | 0 | 0 | 0 | 0 | 0 | 0 | 0 | | |
| -1 | -0.003617 | 1 | 1 | 1 | 1 | 1 | 1 | 1 | 1 | 1 | 1 | 1 | 1 | 1 | 1 | 1 | Under-range | |
| -6912 | -25.000 | 1 | 1 | 1 | 0 | 0 | 1 | 0 | 1 | 0 | 0 | 0 | 0 | 0 | 0 | 0 | | |
| -6913 | | 1 | 1 | 1 | 0 | 0 | 1 | 0 | 0 | 1 | 1 | 1 | 1 | 1 | 1 | 1 | Limited to over-range lower limit 0 V and 0 mA | |
| -32512 | -25.000 | 1 | 0 | 0 | 0 | 0 | 0 | 0 | 1 | 0 | 0 | 0 | 0 | 0 | 0 | 0 | | |
| ≤ -32513 | -25% | 1 | 0 | 0 | 0 | 0 | 0 | 0 | 0 | x | x | x | x | x | x | x | Under-flow | |

Analog Value Representation in Voltage Output Ranges

Table 5-34 Analog Value Representation in Output Range ± 10 V

| System | | | Voltage Output Range | |
|------------|---------|------|----------------------|--|
| | Dec. | Hex. | ± 10 V | |
| 118.5149% | 32767 | 7FFF | 0.00 V | Overflow, off circuit and deenergized |
| | 32512 | 7F00 | | |
| 117.589% | 32511 | 7EFF | 11.76 V | Overrange |
| | 27649 | 6C01 | | |
| 100% | 27648 | 6C00 | 10 V | Rated range |
| 75% | 20736 | 5100 | 7.5 V | |
| 0.003617% | 1 | 1 | 361.7 μ V | |
| 0% | 0 | 0 | 0 V | |
| | -1 | FFFF | - 361.7 μ V | |
| - 75% | - 20736 | AF00 | - 7.5 V | |
| - 100% | -27648 | 9400 | - 10 V | |
| | -27649 | 93FF | | Underrange |
| -117.593% | -32512 | 8100 | - 11.76 V | |
| | - 32513 | 80FF | | Underflow, off circuit and deenergized |
| - 118.519% | -32768 | 8000 | 0.00 V | |

Table 5-35 Analog Value Representation in Output Ranges 0 to 10 V and 1 to 5 V

| System | | | Voltage Output Range | | |
|------------|---------|------|----------------------|------------------|--|
| | Dec. | Hex. | 0 to 10 V | 1 to 5 V | |
| 118.5149% | 32767 | 7FFF | 0.00 V | 0.00 V | Overflow, off circuit and deenergized |
| | 32512 | 7F00 | | | |
| 117.589% | 32511 | 7EFF | 11.76 V | 5.70 V | Overrange |
| | 27649 | 6C01 | | | |
| 100% | 27648 | 6C00 | 10 V | 5 V | Rated range |
| 75% | 20736 | 5100 | 7.5 V | 3.75 V | |
| 0.003617% | 1 | 1 | 361.7 μ V | 1V+144.7 μ V | |
| 0% | 0 | 0 | 0 V | 1 V | |
| | -1 | FFFF | | | |
| - 25% | -6912 | E500 | | 0 V | Underrange |
| | -6913 | E4FF | | | |
| -117.593% | -32512 | 8100 | | | Not possible. The output value is limited to 0 V. |
| | - 32513 | 80FF | | | Underflow, off circuit and deenergized |
| - 118.519% | -32768 | 8000 | 0.00 V | 0.00 V | |

Analog Value Representation in Current Output Ranges

Table 5-36 Analog Value Representation in Output Range ± 20 mA

| System | | | Current Output Range | |
|------------|---------|------|----------------------|--|
| | Dec. | Hex. | ± 20 mA | |
| 118.5149% | 32767 | 7FFF | 0.00 mA | Overflow, off circuit and deenergized |
| | 32512 | 7F00 | | |
| 117.589% | 32511 | 7EFF | 23.52 mA | Overrange |
| | 27649 | 6C01 | | |
| 100% | 27648 | 6C00 | 20 mA | Rated range |
| 75% | 20736 | 5100 | 15 mA | |
| 0.003617% | 1 | 1 | 723.4 nA | |
| 0% | 0 | 0 | 0 mA | |
| | -1 | FFFF | - 723.4 mA | |
| - 75% | - 20736 | AF00 | - 15 mA | |
| - 100% | -27648 | 9400 | - 20 mA | Underrange |
| | -27649 | 93FF | | |
| -117.593% | -32512 | 8100 | - 23.52 mA | |
| | - 32513 | 80FF | | Underflow, off circuit and deenergized |
| - 118.519% | -32768 | 8000 | 0.00 mA | |

Table 5-37 Analog Value Representation in Output Ranges 0 and 20 mA and 4 to 20 mA

| System | | | Current Output Range | | |
|------------|---------|------|----------------------|--------------|--|
| | Dec. | Hex. | 0 to 20 mA | 4 to 20 mA: | |
| 118.5149% | 32767 | 7FFF | 0.00 mA | 0.00 mA | Overflow, off circuit and deenergized |
| | 32512 | 7F00 | | | |
| 117.589% | 32511 | 7EFF | 23.52 mA | 22.81 mA | Overrange |
| | 27649 | 6C01 | | | |
| 100% | 27648 | 6C00 | 20 mA | 20 mA | Rated range |
| 75% | 20736 | 5100 | 15 mA | 15 mA | |
| 0.003617% | 1 | 1 | 723.4 nA | 4mA+578.7 nA | |
| 0% | 0 | 0 | 0 mA | 4 mA | |
| | -1 | FFFF | | | Underrange |
| - 25% | -6912 | E500 | | 0 mA | |
| | -6913 | E4FF | | | Not possible. The output value is limited to 0 mA. |
| -117.593% | -32512 | 8100 | | | |
| | - 32513 | 80FF | | | Underflow, off circuit and deenergized |
| - 118.519% | -32768 | 8000 | 0.00 mA | 0.00 mA | |

5.4 Setting the Measuring Method and Measuring Ranges of the Analog Input Channels

Two Procedures

There are two procedures for setting the measuring method and the measuring ranges of the analog input channels of the analog modules:

- With a measuring range module and *STEP 7*
- By wiring the analog input channel and *STEP 7*

Which of these two methods is used for the individual analog modules depends on the module and is described in detail in the specific module sections.

The procedure for setting the measuring method and measuring range of the module in *STEP 7* is described in Section 5.7.

The following section describes how you set the measuring method and the measuring range by means of measuring range modules.

Setting the Measuring Method and the Measuring Ranges with Measuring Range Modules

If the analog modules have measuring range modules, they are supplied with the measuring range modules plugged in.

If necessary, the measuring range modules must be replugged to change the measuring method and the measuring range.

Attention

Make sure that the measuring range modules are on the side of the analog input module.

Before installing the analog input module, therefore, check whether the measuring range modules have to be set to another measuring method and another measuring range.

Possible Settings for the Measuring Range Modules

The measuring range modules can be set to the following positions: "A", "B", "C" and "D".

Which measuring range module positions you must select for the individual measuring methods and measuring ranges is described in detail in the specific module section.

The settings for the various types of measurement and measuring ranges are also printed on the analog module.

Replugging Measuring Range Modules

If you want to replug a measuring range module, perform the following steps:

1. Use a screwdriver to ease the measuring range module out of the analog input module.

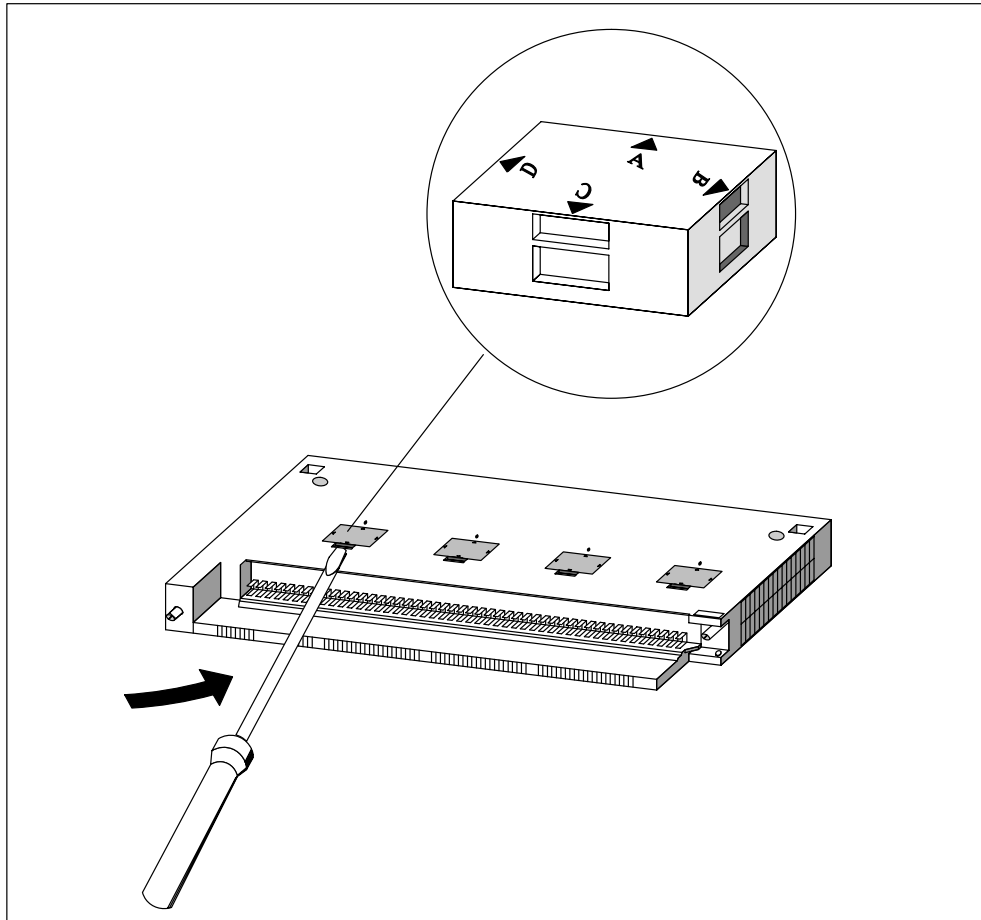

Figure 5-1 Levering the Measuring Range Module out of the Analog Input Module

2. Insert the measuring range module (correctly positioned (1)) into the analog input module.

The measuring range selected is the one that points to marker point on module (2).

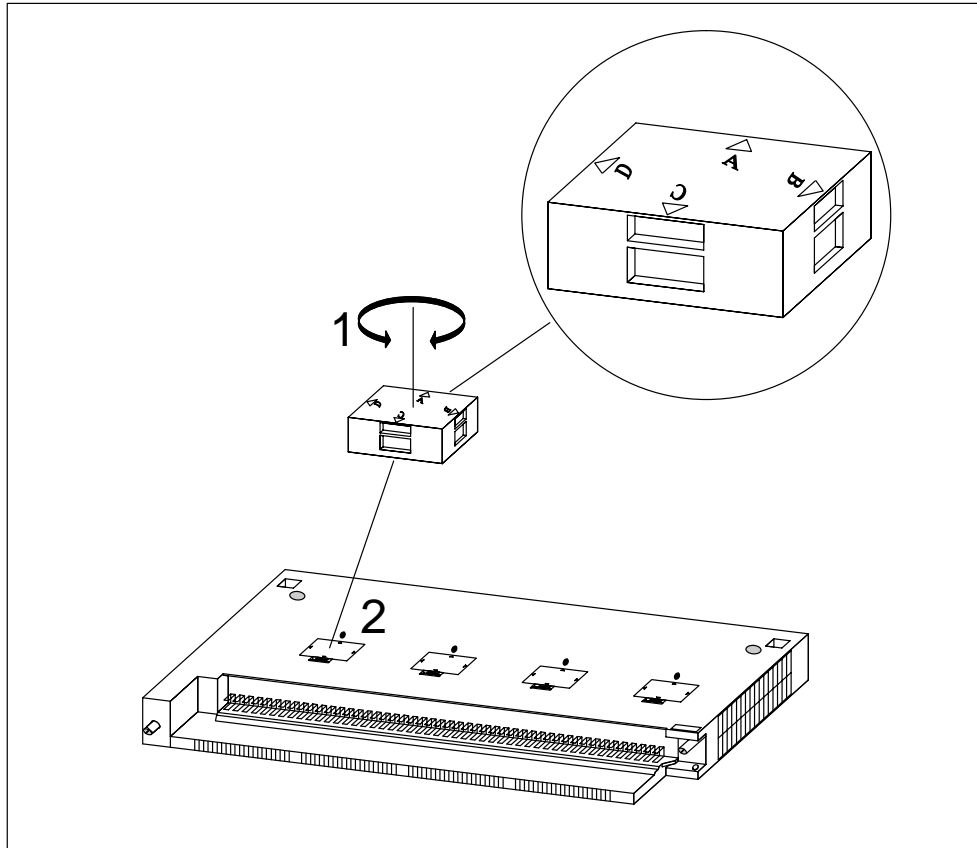

Figure 5-2 Inserting the Measuring Range Module into the Analog Input Module

Perform the same steps for all other measuring range modules.

The next step is to install the module.



Caution

This can result in damage.

If you have not set the measuring range modules correctly, the module may be destroyed.

Make sure that the measuring range module is in the correct position before connecting a sensor to the module.

5.5 Behavior of the Analog Modules

Introduction

In this section, you will find information on:

- How the analog input and output values depend on the operating modes of the CPU and the supply voltage of the analog module
- The behavior of the analog modules depending on where the analog values lie within the value range
- The effect of errors on analog modules with diagnostics capability
- The effect of the operational limit of the analog module on the analog input and output value, as illustrated by an example

5.5.1 Effect of Supply Voltage and Operating Mode

The input and output values of the analog modules depend on the operating mode of the CPU and on the supply voltage of the module.

Table 5-38 Dependencies of the Analog Input/Output Values on the Operating Mode of the CPU and the Supply Voltage L+

| CPU Operating Mode | | Supply Voltage L+ at Analog Module | Output Value of the Analog Output Module | Input Value of the Analog Input Module* |
|--------------------|------|------------------------------------|--|--|
| POWER ON | RUN | L+ present | CPU values Until the first conversion... <ul style="list-style-type: none"> • after power-up has been completed, a signal of 0 mA or 0 V is output. • after parameter assignment has been completed, the previous value is output. | Measured value |
| | | L+ missing | 0 mA/0 V | 7FFF _H until the first conversion following power-up or after parameter assignment of the module has been completed |
| POWER ON | STOP | L+ present | Substitute value/last value (default values: 0 mA/0 V) | Measured value |
| | | L+ missing | 0 mA/0 V | 7FFF _H until the first conversion following power-up or after parameter assignment of the module has been completed |
| POWER OFF | – | L+ present | 0 mA/0 V | – |
| | | L+ missing | 0 mA/0 V | – |

* L+ only required with 2-wire transmitters

Behavior on Failure of the Supply Voltage

Failure of the load power supply L+ of the diagnostics-capable analog module is indicated in the case of parameterized two-wire transmitters by the EXTF LED on the module. Furthermore, this information is made available on the module (entry in diagnostic buffer).

Triggering of a diagnostic interrupt depends on the parameter assignment (see Section 5.7).

5.5.2 Effect of Range of Values of the Analog Values

Effect of Errors on Analog Modules with Diagnostics Capability

Any errors that occur can lead to a diagnostics entry and a diagnostic interrupt with analog modules with diagnostics capability and corresponding parameter assignment. You will find the errors that might be involved in Section 5.16.

Effect of Range of Values on the Analog Input Module

The behavior of the analog modules depends on where the input values lie within the range of values.

Table 5-39 Behavior of the Analog Input Modules as a Function of the Position of the Analog Value Within the Range of Values

| Measured Value In | Input Value | LED (EXTF) | Diagnostics | Interrupt |
|-----------------------------|----------------|----------------------|----------------------|-----------------------------------|
| Rated range | Measured value | – | – | – |
| Ovrange/ underrange | Measured value | – | – | – |
| Overflow | 7FFFH | Flashes ¹ | Entered ¹ | Diagnostic interrupt ¹ |
| Underflow | 8000H | Flashes ¹ | Entered ¹ | Diagnostic interrupt ¹ |
| Beyond the programmed limit | Measured value | – | – | Hardware interrupt ¹ |

¹⁾ Only for modules with diagnostics capability and depending on parameter assignment

Effect of Range of Values on the Analog Output Module

The behavior of the analog modules depends on where the output values lie within the value range.

Table 5-40 Behavior of the Analog Output Modules as a Function of the Position of the Analog Value Within the Range of Values

| Process Value Lies Within | Output Value | LED (EXTF) | Diagnostics | Interrupt |
|---------------------------|--------------|------------|-------------|-----------|
| Rated range | CPU value | – | – | – |
| Ovrange/underrange | CPU value | – | – | – |
| Overflow | 0 signal | – | – | – |
| Underflow | 0 signal | – | – | – |

5.5.3 Effect of Operational Limit and Basic Error Limit

Operational Limit

The operational limit is the measuring error or output error of the analog module over the entire temperature range authorized for the module, referred to the rated range of the module.

Basic Error Limit

The basic error limit is the operational limit at 25°C, referred to the rated range of the module.

Note

The percentage details of operational and basic error limits in the technical specifications of the module always refer to the **highest possible** input and output value in the rated range of the module.

Example of Determination of the Output Error of a Module

An analog output module SM 432; AO 8 × 13 Bit is being used for voltage output. The output range “± 10 V” is used. The module is operating at an ambient temperature of 30°C. The operational limit thus applies. The technical specifications of the module state:

- Operational limit for voltage output: $\times \pm 0.5\%$

An output error, therefore, of $\pm 0.05 \text{ V}$ ($\pm 0.5\%$ of 10 V) over the whole rated range of the module must be expected.

This means that with an actual voltage of, say, 1 V, a value in the range from 0.95 V to 1.05 V is output by the module. The relative error is $\pm 5\%$ in this case.

The figure below shows for the example how the relative error becomes increasingly less the more the output value approximates to the end of the rated range of 10 V.

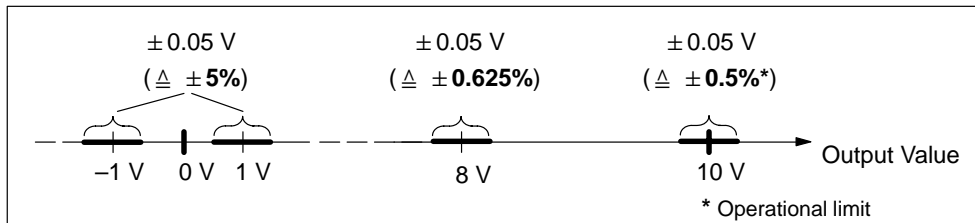

Figure 5-3 Example of the Relative Error of an Analog Output Module

5.6 Conversion, Cycle, Setting and Response Time of Analog Modules

Conversion Time of Analog Input Channels

The conversion time consists of a basic conversion time and additional processing times of the module for:

- Resistance test
- Wire-break monitoring

The basic conversion time depends directly on the conversion method of the analog input channel (integrating method, instantaneous value conversion).

In the case of integrating conversion methods, the integration time has a direct influence on the conversion time. The integration time depends on the interference frequency suppression that you set in *STEP 7* (refer to Section 4.3.1).

To find out the basic conversion times and additional processing times of the different analog modules, refer to the technical specifications of the module concerned, starting at Section 5.18.

Scan Time of Analog Input Channels

Analog-to-digital conversion and the transfer of the digitized measured values to the memory and/or to the bus backplane are performed sequentially – in other words, the analog input channels are converted one after the other. The scan time – in other words, the time elapsing until an analog input value is again converted, is the sum of the conversion times of all activated analog input channels of the analog input module.

The following figure illustrates the components of the scan time for an n-channel analog module.

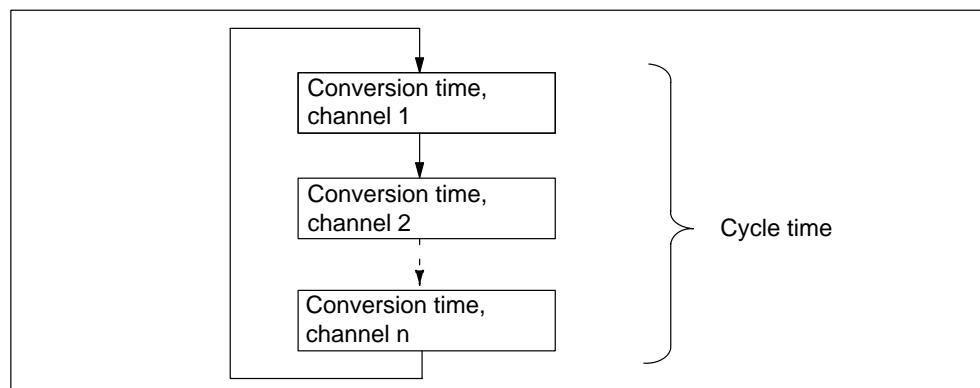

Figure 5-4 Scan Time of an Analog Input or Output Module

Basic Execution Time of the Analog Input Channels

The basic execution time corresponds to the cycle time for all the enabled channels.

Setting the Smoothing of Analog Values

You can set the smoothing of the analog values in *STEP 7* for some analog input modules.

Using Smoothing

Smoothing of analog values ensures a stable analog signal for further processing.

It makes sense to smooth the analog values with slow variations of measured values – for example, with temperature measurements.

Smoothing Principle

The measured values are smoothed by digital filtering. Smoothing is accomplished by the module calculating average values from a defined number of converted (digitized) analog values.

The user assigns parameters to smoothing at not more than four levels (none, low, average, high). The level determines the number of analog signals used for averaging.

The higher the smoothing level chosen, the more stable is the smoothed analog value and the longer it takes until the smoothed analog signal is applied after a step response (refer to the following example).

Example

The following figure shows the number of module cycles for a step response after which the smoothed analog value is approximately 100% applied, as a function of the smoothing that has been set. The figure applies to every change of signal at the analog input.

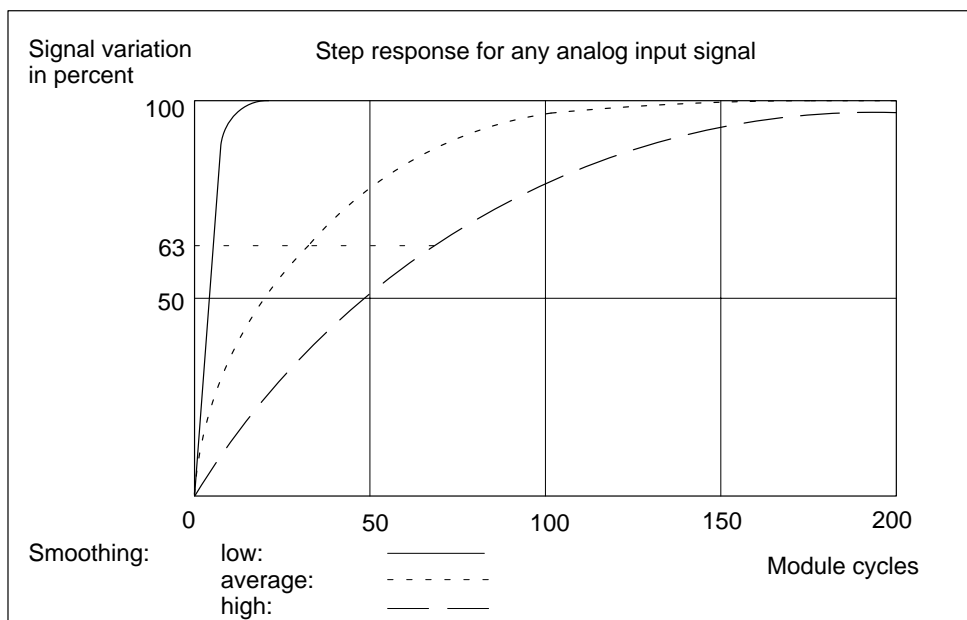

Figure 5-5 Example of the Influence of Smoothing on the Step Response

Additional Information on Smoothing

Refer to the specific section on the analog input module (from Section 5.18) to determine whether smoothing can be set for the specific module and for any special features that have to be taken into account.

Conversion Time of the Analog Output Channels

The conversion time of the analog output channels comprises the transfer of the digitized output values from the internal memory and the digital-to-analog conversion.

Scan Time of Analog Output Channels

The analog output channels are converted sequentially – in other words, the analog output channels are converted one after the other.

The scan time – in other words, the time elapsing until an analog output value is again converted – is the sum of the conversion times of all activated analog output channels (refer to 5-4).

Basic Execution Time of the Analog Output Channels

The basic execution time corresponds to the cycle time for all the enabled channels.

Tip

You should disable any analog channels that are not being used to reduce the scan time in *STEP 7*.

Overview of the Settling Time and Response Time of the Analog Output Modules

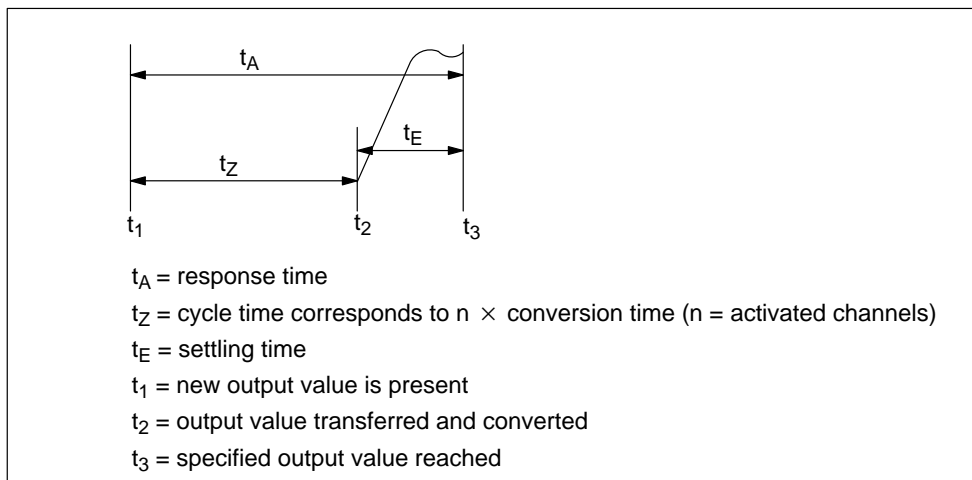

Figure 5-6 Settling and Response Times of the Analog Output Channels

Settling Time

The settling time (t_2 to t_3) – in other words, the time elapsing from application the converted value until the specified value is reached at the analog output – is load-dependent. A distinction is made between resistive, capacitive and inductive loads.

For the settling times of the different analog output modules as a function of load refer to the technical specifications of the module concerned, starting at Section 5.25.

Response Time

The response time (t_1 to t_3) – in other words, the time elapsing from application of the digital output values in the internal memory until the specified value is reached at the analog output – in a worst case scenario is the sum of the scan time and the settling time.

You have a worst case situation if, shortly prior to the transfer of a new output value, the analog channel has been converted and is not converted again until all other channels are converted (cycle time).

5.7 Analog Module Parameter Assignment

Introduction

Analog modules can have different characteristics. You can set the characteristics of the modules by means of parameter assignment.

Tools for Parameter Assignment

You assign parameters to analog modules with *STEP 7*. You must perform parameter assignment in STOP mode of the CPU.

When you have set all the parameters, download the parameters from the programming device to the CPU. When there is a transition from STOP to RUN mode, the CPU transfers the parameters to the individual analog modules.

In addition, if necessary you must place the measuring range modules of the module in the necessary position (refer to Section 5.4).

Static and Dynamic Parameters

The parameters are divided into static and dynamic parameters.

Set the static parameters in STOP mode of the CPU, as described above.

You can similarly modify the dynamic parameters in the current user program by means of SFCs. Note, however, that after a change from RUN → STOP, STOP → RUN of the CPU, the parameters set in *STEP 7* apply again. You will find a description of the parameter assignment of modules in the user program in Appendix A.

Table 5-41 Static and dynamic parameters of the analog groups

| Parameter | Settable with | CPU Operating Mode |
|-----------|----------------------------|--------------------|
| Static | PG (STEP 7 HWCONFIG) | STOP |
| Dynamic | PG (STEP 7 HWCONFIG) | STOP |
| | SFC 55 in the user program | RUN |

5.7.1 Parameters of the Analog Input Modules

The analog input modules use a subset of the parameters and ranges of values listed in the table below, depending on the functionality. Refer to the section on the module concerned, starting from Section 5.18, to find out which subset the module is capable of using.

The default settings apply if you have not performed parameter assignment in *STEP 7*.

Table 5-42 Parameters of the Analog Input Modules

| Parameter | Value Range | Default ²⁾ | Parameter Type | Scope |
|--|--|----------------------------|----------------|---------|
| Enable <ul style="list-style-type: none"> • Diagnostic interrupt¹⁾ • Hardware interrupt¹⁾ • Destination CPU for interrupt | Yes/no | No | Dynamic | Module |
| | Yes/no | No | | |
| | 1 to 4 | – | Static | Module |
| Trigger for hardware interrupt <ul style="list-style-type: none"> • End of scan cycle reached at input • High limit • Low limit | Yes/no | No | Static | Channel |
| | Constraint possible due to measuring range 32511 to – 32512 – 32512 to 32511 | – | Dynamic | Channel |
| Diagnostics <ul style="list-style-type: none"> • Wire break • Reference channel error • Underflow • Overflow • Short circuit to M | Yes/no Yes/no Yes/no Yes/no Yes/no | No No No No No | Static | Channel |

Table 5-42 Parameters of the Analog Input Modules, continued

| Parameter | Value Range | Default ²⁾ | Parameter Type | Scope |
|---|--|-----------------------|----------------|---------|
| Measurement | | | | |
| • Measuring type | Disabled U Voltage 4DMU Current (four-wire transmitter) 2DMU Current (two-wire transmitter) R-4L Resistance (four-conductor connection) R-3L Resistance three-conductor connection RTD-4L Thermal resistor (linear, four-conductor connection) RTD-3L Thermal resistor (linear, three-conductor connection) TC-L Thermocouple (linear) | U | Static | Channel |
| • Measuring range | For the settable measuring ranges of the input channels, please refer to the individual module description. | ± 10 V | | |
| • Reference temperature | - 273.15 to 327.67 °C | 0 °C | Dynamic | Module |
| • Temperature unit | Degrees Celsius; degrees Fahrenheit; Kelvins | Degrees Celsius | Static | Module |
| • Temperature coefficient for temperature measurement with thermal resistor (RTD) | Platinum (Pt) 0.00385 $\Omega/\Omega/^\circ\text{C}$ 0.003916 $\Omega/\Omega/^\circ\text{C}$ 0.003902 $\Omega/\Omega/^\circ\text{C}$ 0.003920 $\Omega/\Omega/^\circ\text{C}$ Nickel (Ni) 0.00618 $\Omega/\Omega/^\circ\text{C}$ 0.00672 $\Omega/\Omega/^\circ\text{C}$ | 0.00385 | Static | Channel |
| • Interference frequency suppression | 400 Hz; 60 Hz; 50 Hz; 10 Hz; none | 50 or 60 Hz | | |
| • Smoothing | None Low Average High | None | | |
| • Reference junction | None Internal RTD on channel 0 Reference temperature value dynamic | None | | |

1) If you use the module in ER-1/ER-2, you must set this parameter to “No” because the interrupt lines are not available in ER-1/ER-2.

2) Only in the CC (central controller) is it possible to start up the analog modules with the default settings.

5.7.2 Parameters of the Analog Output Modules

The analog output modules use a subset of the parameters and ranges of values listed in the table below, depending on the functionality. Refer to the section on the module concerned, starting from Section 5.25, to find out which subset the module is capable of using.

The default settings apply if you have not performed parameter assignment in *STEP 7*.

Table 5-43 Parameters of the Analog Output Modules

| Parameter | Value Range | Default ¹ | Parameter Type | Scope |
|------------------|--|----------------------|----------------|---------|
| Output | | | | |
| • Type of output | Disabled Voltage Current | U | Static | Channel |
| • Output range | For the settable measuring ranges of the output channels, please refer to the individual module description. | ± 10 V | | |

¹⁾ Only in the CC (central controller) is it possible to start up the analog modules with the default settings.

5.8 Connecting Sensors to Analog Inputs

Introduction

You can connect different sensors to the analog input modules depending on the measuring method; voltage and current sensors, and resistors.

This section contains general information that is generally applicable to all the connection options for sensors described in the sections that follow.

Cables for Analog Signals

To reduce electrical interference, you should use twisted-pair shielded cables for the analog signals. The shield of the analog signal cables should be grounded at both cable ends.

If there are potential differences between the cable ends, an equipotential bonding current can flow over the shield, which leads to an interference of the analog signals. In such a case, you should ground the shield at one end of the cable only.

Non-Isolated Analog Input Modules

In the case of the non-isolated analog input modules there is an electrical connection between the reference point of the measuring circuit M_{ANA} and chassis ground.

You use non-isolated analog modules if there are few or no potential differences between the measuring sensors and chassis ground.

Isolated Analog Input Modules

With the isolated analog input modules there is no electrical connection between the reference point of the measuring circuit M_{ANA} and chassis ground.

You use isolated analog input modules if a potential difference U_{ISO} can occur between the reference point of the measuring circuit M_{ANA} and chassis ground. By means of an equipotential bonding conductor between the M_{ANA} terminal and chassis ground, make sure that U_{ISO} does not exceed the permitted value.

Limited Potential Difference U_{CM}

Only a limited potential difference U_{CM} (common mode voltage) may occur amongst the $M-$ measuring lines of the input channels and between the leads and the reference point of the measuring circuit M_{ANA} . In order to prevent the permissible value from being exceeded, you must take different actions, described below, depending on the potential connection of the sensors.

Abbreviations and Mnemonics Used in the Figures Below

The abbreviations and mnemonics used in the figures below have the following meanings:

- M +: Measuring line (positive)
- M -: Measuring line (negative)
- M_{ANA}: Reference potential of the analog measuring circuit
- U_{CM}: Potential difference between inputs and reference potential of the M_{ANA} measuring circuit
- U_{ISO}: Potential difference between M_{ANA} and chassis ground

Connection of Isolated Measuring Sensors

The isolated sensors are not connected with the local ground potential (local ground). They can be operated free of potential.

With isolated sensors, potential differences might arise between the different sensors. These potential differences can arise as a result of interference or the local distribution of the sensors.

To ensure that the permissible value for U_{CM} is not exceeded during use in heavily EMC-affected environments, connect M- to M_{ANA} in modules with an M_{ANA} connection.

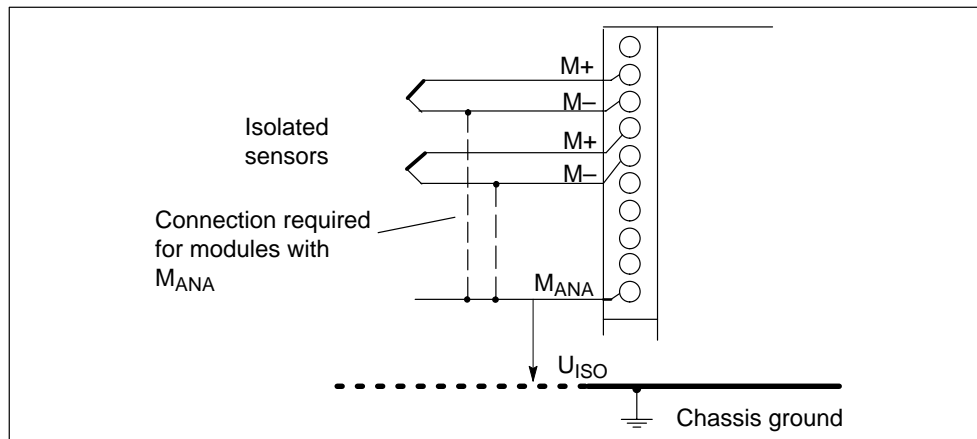

Figure 5-7 Connecting Isolated Sensors to an Isolated AI

Note

Do not connect M- to M_{ANA} when connecting two-wire transmitters for current measurement and when connecting resistance-type sensors. This also applies to inputs which are not used.

Non-Isolated Sensors

The non-isolated sensors are connected with the local ground potential (local ground). When using non-isolated sensors, you must connect M_{ANA} to chassis ground.

Connecting Non-Isolated Sensors

Caused by local conditions or interference, potential differences U_{CM} (static or dynamic) can occur between the locally distributed individual measuring points. If the potential difference U_{CM} exceeds the permissible value, you must provide equipotential bonding conductors between the measuring points.

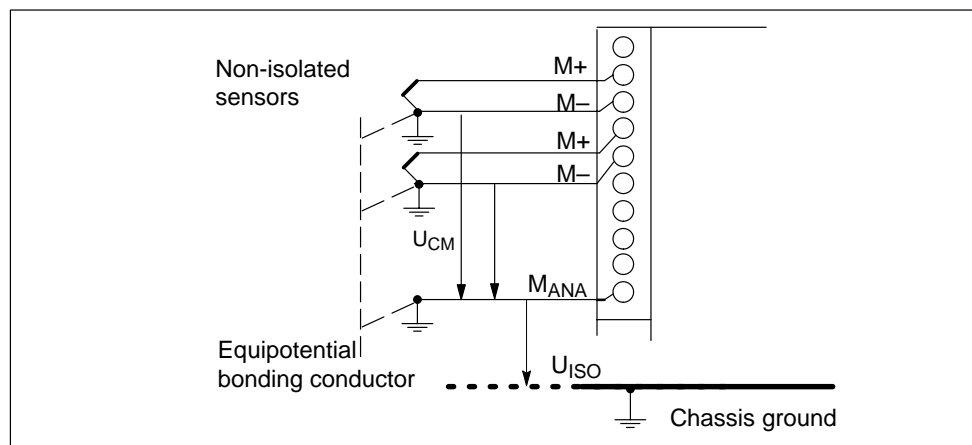

Figure 5-8 Connecting Non-Isolated Sensors to an Isolated AI

Note

Do not use non-isolated two-wire transmitters and non-isolated resistance sensors!

5.9 Connecting Voltage Sensors

Note

The necessary connecting cables, which result from the potential connection of the analog input module and the sensors, are not drawn in the figures shown below.

In other words, you must continue to take note of and implement Section 5.8 with its generally applicable information on connecting sensors.

Abbreviations and Mnemonics Used in the Figure Below

The abbreviations and mnemonics used in the figure below have the following meanings:

- M +: Measuring line (positive)
- M -: Measuring line (negative)
- M_{ANA}: Reference potential of the analog measuring circuit

Connection of Voltage Sensors

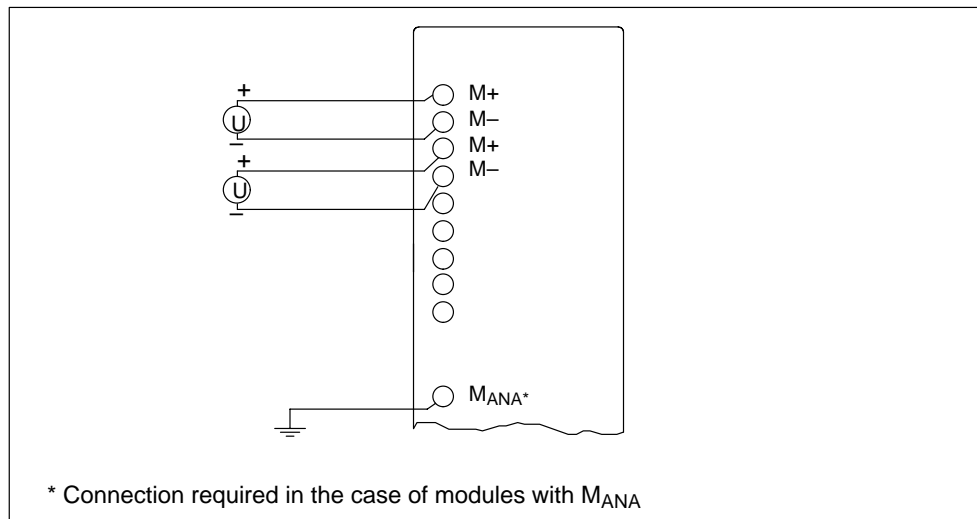

Figure 5-9 Connecting Voltage Sensors to an AI

5.10 Connecting Current Sensors

Note

The necessary connecting cables, which result from the potential connection of the analog input module and the sensors, are not drawn in the figures shown below.

In other words, you must continue to take note of and implement Section 5.8 with its generally applicable information for connecting sensors.

Abbreviations and Mnemonics Used in the Figures Below

The abbreviations and mnemonics used in the figures below have the following meanings:

| | |
|--------------------|---|
| M +: | Measuring line (positive) |
| M –: | Measuring line (negative) |
| M _{ANA} : | Reference potential of the analog measuring circuit |
| M : | Ground terminal |
| L +: | Terminal for 24 VDC supply voltage |
| U _H : | Auxiliary supply |
| M _{I+} : | Current measuring line (positive) |
| M _{V+} : | Voltage measuring line (positive) |

Supply Voltage of the Sensors

The two-wire transmitter receives its short-circuit-proof power supply via the terminals of the analog input module.

This transmitter then converts the measured variable into a current.

Because the two-wire transmitter is supplied by the module, you must **not** ground the M- cables.

Four-wire transmitters require a separate supply voltage U_H (auxiliary supply).

Connecting Two-Wire Transmitters

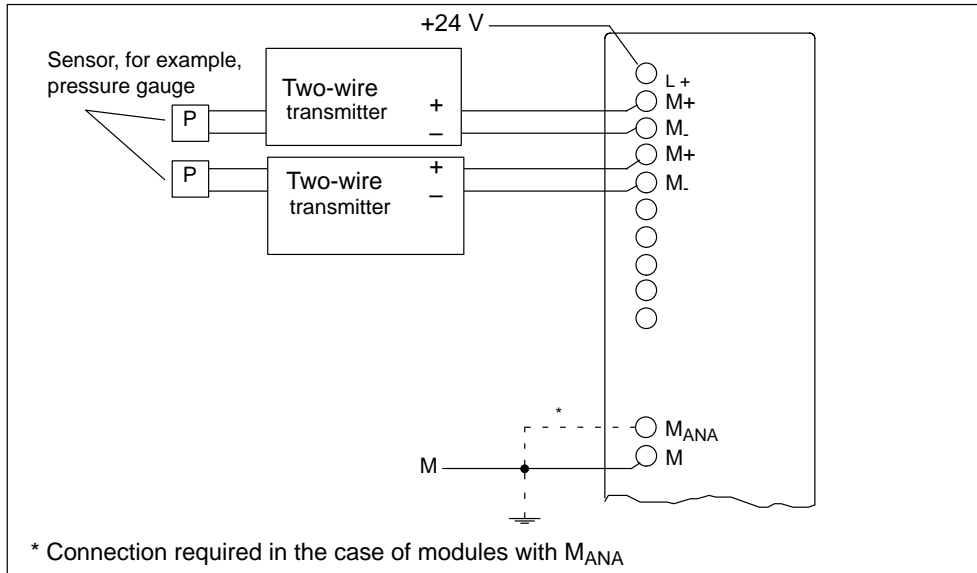

Figure 5-10 Connecting Two-Wire Transmitters to an Isolated AI

SM 431; 8 x 13 Bit: Connecting Two-Wire Transmitters

Because the supply voltage for the two-wire transmitters is not fed by the SM 431; 8 x 13 Bit, you must supply the sensors separately with 24 V.

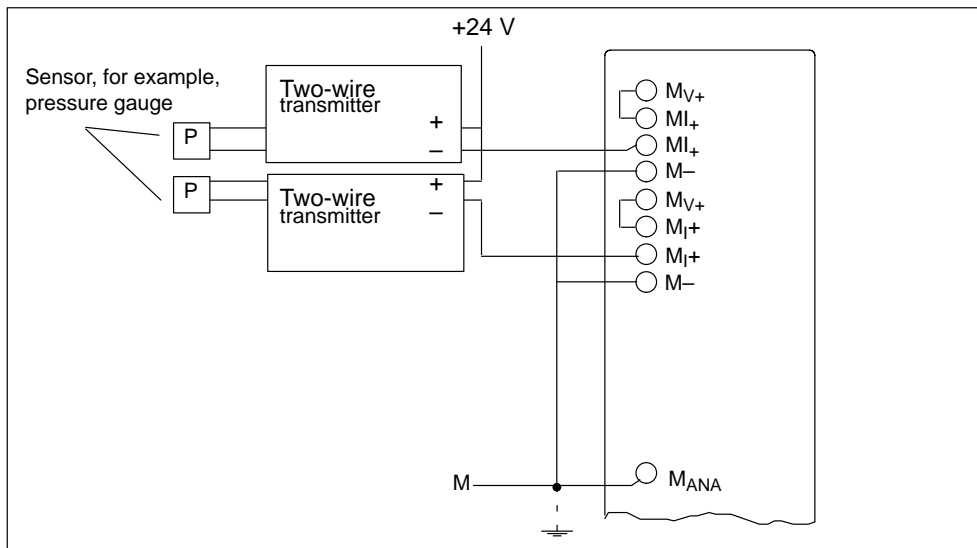

Figure 5-11 Connecting Two-Wire Transmitters to an SM 431; 8 x 13 Bit

Connecting Four-Wire Transmitters

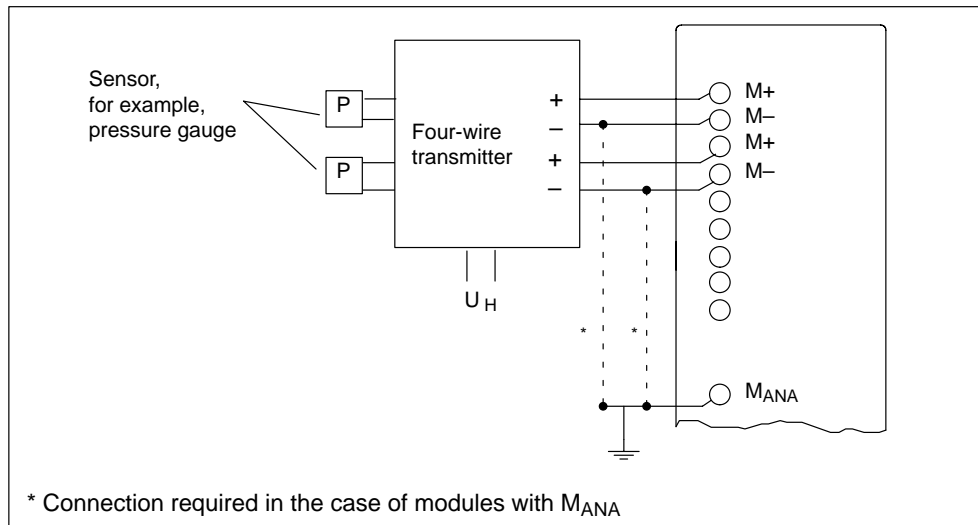

Figure 5-12 Connecting Four-Wire Transmitters to an AI

SM 431; 8 x 13 Bit: Connecting Four-Wire Transmitters

To ensure that the permissible value for U_{CM} is not exceeded, you must connect the M- cables to M_{ANA}.

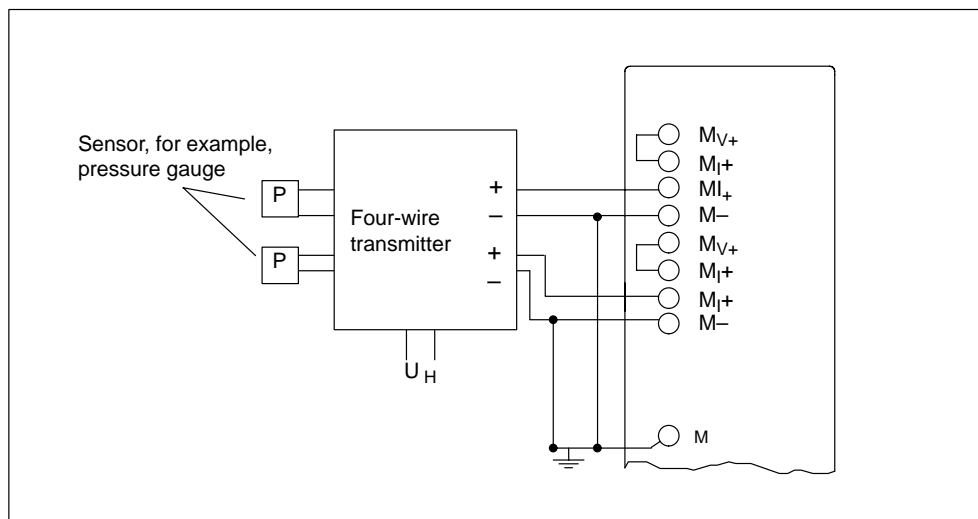

Figure 5-13 Connecting Four-Wire Transmitters to an SM 431; 8 x 13 Bit

5.11 Connecting Resistance Thermometers and Resistors

Note

The necessary connecting cables, which result from the potential connection of the analog input module and the sensors, are not drawn in the figures shown below.

In other words, you must continue to take note of and implement Section 5.8 with its generally applicable information for connecting sensors.

Abbreviations and Mnemonics Used in the Figures Below

The abbreviations and mnemonics used in the figures below have the following meanings:

| | |
|------------|----------------------------------|
| I_{C+} : | Constant-current lead (positive) |
| I_{C-} : | Constant-current lead (negative) |
| M_+ : | Measuring line (positive) |
| M_- : | Measuring line (negative) |

Connecting Resistance Thermometers and Resistors

The resistance thermometers/resistors are wired in a four-conductor, three-conductor or two-conductor connection.

With four-conductor and three-conductor connections, the module supplies a constant current via terminals I_{C+} and I_{C-} so that the potential drop occurring on the measuring cables is compensated. It is important that the connected constant current cables are directly connected to the resistance thermometer/resistor.

Measurements with four-conductor or three-conductor connections supply a more precise measuring result due to compensation than measurements with a two-conductor connection.

Four-Conductor Connection of a Resistance Thermometer

The voltage generated at the resistance thermometer is measured via the M_+ and M_- terminals. When you connect, watch out for the polarity of the connected cable (connect $I_C +$ and M_+ as well as $I_C -$ and M_- to the resistance thermometer).

Make sure that the connected cables **$I_C +$ and M_+** and **SO and $SE+$** and cables **$I_C -$ and M_-** and **$AGND$ and $SE-$** are connected directly on the resistance thermometer.

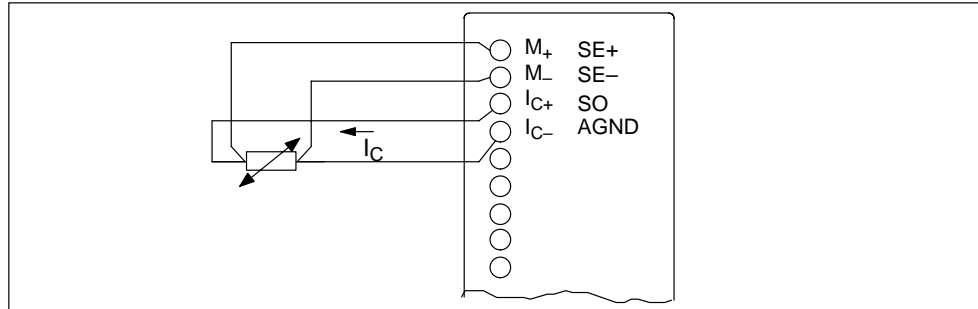

Figure 5-14 Four-Conductor Connection of Resistance Thermometers on an AI

Three-Conductor Connection of a Resistance Thermometer

During three-conductor connection to modules with 4 terminals per resistance thermometer, you must set up a **jumper between M₋ and I_{C-}** and **SE₋ and AGND** (see Figure 5-15).

The module compensates in this circuit for the effect of the line resistance between the module and the resistance thermometer/resistor.

Make sure that the connected cables **I_{C+}** and **M₊** and the cables **SO** and **SE₊** are directly connected to the resistance thermometer.

To get an accurate measurement, make sure that the connected cables **M₊**, **I_{C+}** and **I_{C-}** and the cables **SE₊**, **SO** and **AGND** are the same length and have the same cross-section.

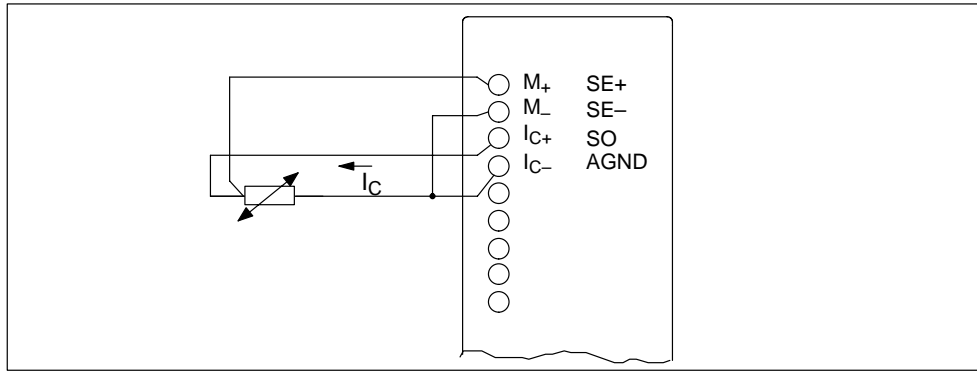

Figure 5-15 Three-Wire Connection of Resistance Thermometers to an AI

Two-Conductor Connection of a Resistance Thermometer

With a two-conductor connection, you must insert jumpers on the module between M₊ and I_{C+} and between M₋ and I_{C-}.

Note: Cable resistance is also measured.

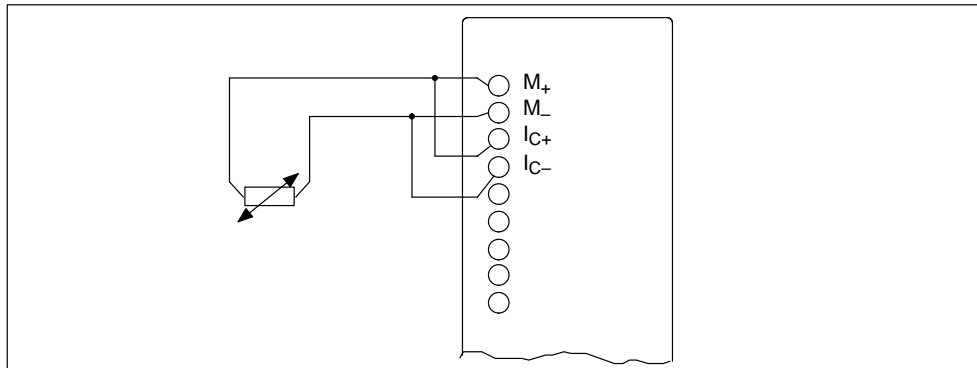

Figure 5-16 Two-Wire Connection of Resistance Thermometers to an AI

5.12 Connecting Thermocouples

Design of Thermocouples

A thermocouple consists of a pair of sensors and the necessary installation and connecting parts. The thermocouple consists of two wires of dissimilar metals or metal alloys soldered or welded together at the ends.

There are different types of thermocouple, depending on the composition of the material used – for example, K, J, N thermocouples. The measuring principle of all thermocouples is the same, irrespective of their type.

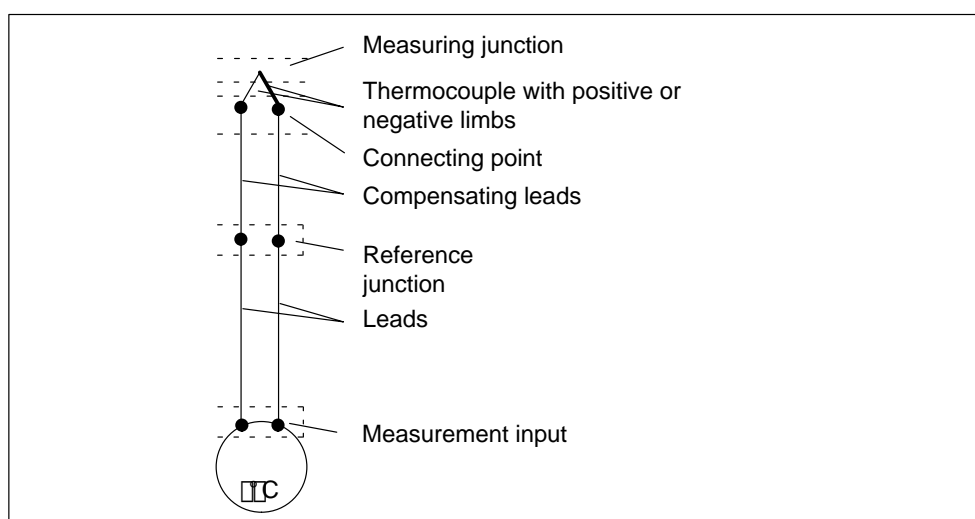

Figure 5-17 Design of Thermocouples

Principle of Operation of Thermocouples

If the measuring point is subjected to a temperature different from that of the free ends of the thermocouple (point of connection), a voltage, the thermo emf, occurs at the free ends. The magnitude of the thermo-e.m.f. generated depends on the difference between the temperature at the measuring junction and the temperature at the free ends, as well as on the material combination used for the thermocouple.

Since a thermocouple always measures a temperature difference, the free ends must be kept at a known temperature at a reference junction in order to determine the temperature of the measuring junction.

The thermocouples can be extended from their point of connection to the reference junction by means of compensating wires. These compensating wires consist of the same material as the thermocouple wires. The supply leads are copper wire.

Note: Make sure these wires are connected with the correct polarity, otherwise there will be considerable measuring errors.

Compensation of the Reference Junction Temperature

There are several options for you to choose from for acquiring the reference junction temperature in order to obtain an absolute temperature value from the difference in temperature between the reference junction and measuring point.

You can use internal or external compensation, depending on where you want the reference junction to be.

The last column of the following table lists the feature you must set for the “Reference Junction” parameter in *STEP 7*. The reference temperature value is a separate parameter in *STEP 7*.

Table 5-44 Options for Compensation of the Reference Junction Temperature

| Option | Explanation | Ref. Junction |
|---|--|-----------------------------|
| No compensation (refer to Figure 5-18 for connection) | When you want to acquire only the difference in temperature between the measuring point and the reference junction | None |
| Internal compensation (refer to Figure 5-18 for connection) | If you employ internal compensation, the internal temperature of the module is used for comparison purposes. | Internal |
| External compensation with a compensating box in leads of an individual thermocouple (see Figure 5-19 for connection) | You have already acquired and compensated the reference junction temperature using a compensating box, which you have looped into an individual thermocouple. No further processing is necessary owing to the module. | None |
| External compensation with a resistance thermometer to obtain the reference junction temperature (recommended method) (see Figure 5-20 for connection) | You can acquire the reference temperature by means of a resistance thermometer (pt 100) and have it calculated by the module for any thermocouple. | RTD on Channel 0 |
| External compensation with a resistance thermometer when thermocouples with the same reference junction are divided amongst several modules (see Figure 5-20 for connection) | Use a resistance thermometer on a module that measures the reference junction temperature. Read in the climatic temperature value to the CPU and transfer the value to the other modules using SFC55. | RTD on Channel 0 |
| Constant reference junction temperature (thermometer, ice bath; see Figure 5-18 for connection) | If the reference junction temperature is constant and known, you can specify this value in parameter assignment in <i>STEP 7</i> . | Reference temperature value |

Theory of Operation of Internal Compensation

With internal compensation, you can establish the reference point across the terminals of the analog input modules. In this case, you must run the compensating lines right up to the analog module. The internal temperature sensor acquires the temperature of the module and supplies a compensation voltage.

Note that internal compensation is not as accurate as external compensation.

Theory of Operation of External Compensation with Compensating Box

If you employ external compensation, the temperature of the reference junction of the thermocouples is taken into account via a compensating box, for example.

The compensating box contains a bridge circuit calibrated for a definite reference junction temperature. The reference junction is formed by the connections for the ends of the thermocouple's compensating leads.

If the actual temperature deviates from the compensating temperature, the temperature-sensitive bridge resistance changes. This results in a positive or negative compensating voltage, which is added to the thermo-e.m.f.

Abbreviations and Mnemonics Used in the Figures Below

The abbreviations and mnemonics used in the figures below have the following meanings:

- M₊: Measuring line (positive)
- M₋: Measuring line (negative)
- I_{C+}: Constant-current lead (positive)
- I_{C-}: Constant-current lead (negative)

Note

The necessary connecting cables, which result from the potential connection of the analog input module and the sensors, are not drawn in the figures shown below.

In other words, you must continue to take note of and implement Section 5.8 with its generally applicable information for connecting sensors.

Connection of Thermocouples without Compensation or Using the Reference Temperature Value

Connect the thermocouples to the inputs of the module, either directly or by means of compensating lines. Each channel can use a thermocouple type supported by the analog module independently of the other channels.

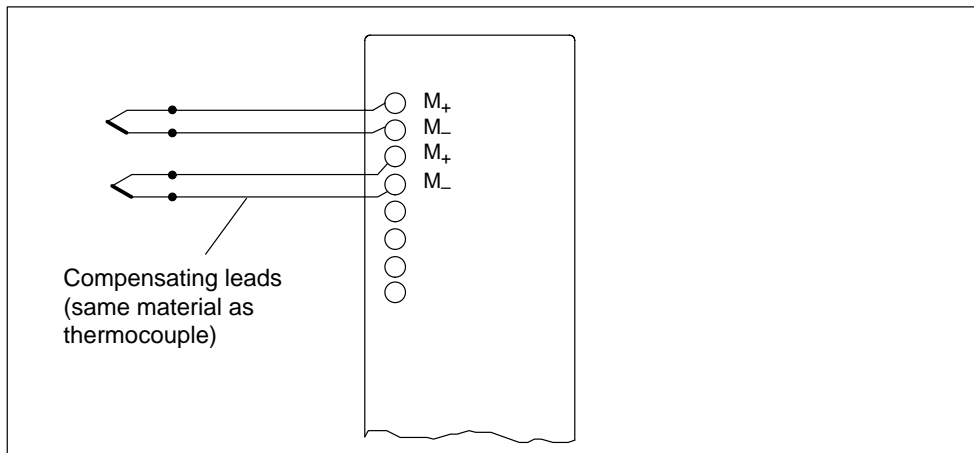

Figure 5-18 Connection of Thermocouples without Compensation or Using the Reference Temperature Value to an Isolated AI

Connecting the Compensating Box

The compensating box is looped in in the leads of each thermocouple. The compensating box must have an isolated supply. The power supply must have adequate filtering, for example by means of a grounded shielding winding.

Each channel can use a thermocouple type supported by the analog module independently of the other channels. Each channel requires its own compensating box.

Note

Use compensating boxes with a **reference junction temperature of 0 °C** for analog input modules.

Recommended Compensating Box

We recommend you to use a comparison point (with integrated power supply unit) from Siemens as a compensating box. You will find the necessary ordering data in the table below.

Table 5-45 Ordering Data of the Comparison Point

| Recommended Compensating Box | | Order Number |
|---|---|--------------|
| Reference junction with integrated power supply unit, for rail mounting | | M72166-□□□□□ |
| Auxiliary power | 220 VAC 110 VAC 24 VAC 24 VDC | |
| Connection to thermocouple | Fe-CuNi Type L Fe/Cu Ni Type J Ni Cr/Ni Type K Pt 10% Rh/Pt Type S Pt 13% Rh/Pt Type R Cu-CuNi Type U Cu/Cu Ni Type T | |
| Reference temperature | 0 °C | 0 0 |

Connecting to the Comparison Point (Order No. M72166-xxx00)

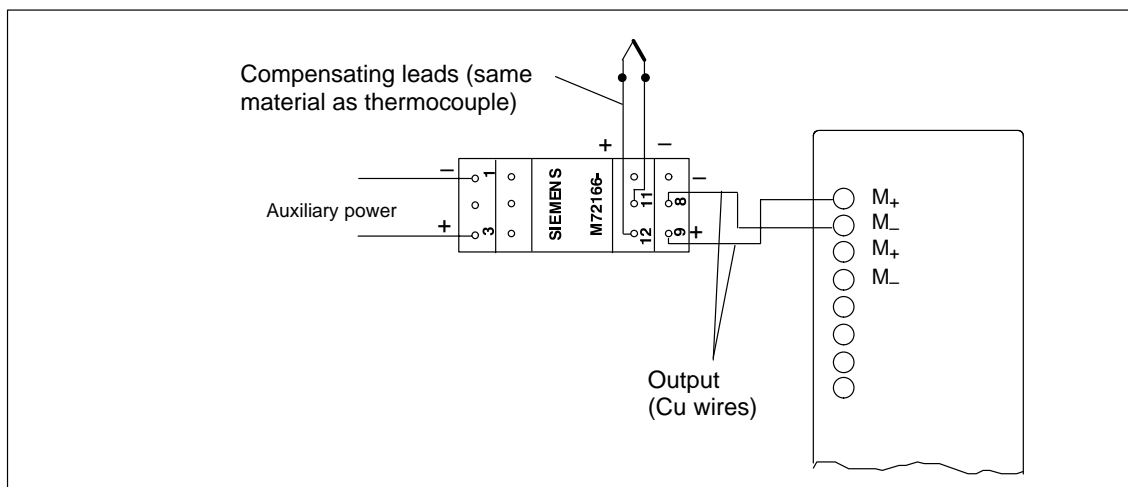

Figure 5-19 Connection of a Thermocouple with Reference Junction (Order No. M72166-xxx00) to an Isolated AI

Connecting Thermocouples and Resistance Thermometers

Connect the resistance thermometer to channel 0 of the module. Make sure that you parameterize the "RTD on Channel 0" reference junction in *STEP 7* for each channel that has a thermocouple connected to it.

If all thermocouples connected to the inputs of the module have the same comparison point, you compensate as follows:

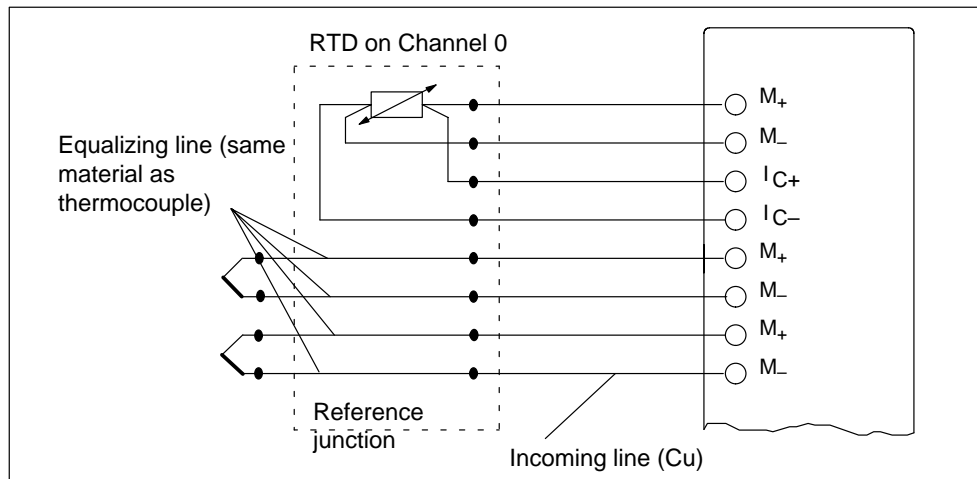

Figure 5-20 Connection of Thermocouples of the Same Type with External Compensation by Means of a Resistance Thermometer, Connected to Channel 0

5.13 Connecting Loads/Actuators to Analog Outputs

Introduction

You can use the analog output modules to supply loads and actuators with current and voltage.

This section contains general information that is generally applicable to all the connection options for loads and actuators described in the sections that follow.

Cables for Analog Signals

For the analog signals, you should use shielded and twisted pair cables. The cables Q_V and S_+ and M and S_- , respectively, are to be twisted together. This reduces the interference. Ground the screen of the analog cables at both ends of the cables.

If there are potential differences between the cable ends, an equipotential bonding current, which can flow over the shield, can cause interference of the analog signals. In such a case, you should ground the shield at one end of the cable only.

Isolated Analog Output Modules

With the isolated analog output modules there is no electrical connection between the reference point of the measuring circuit M_{ANA} and chassis ground.

You must use isolated analog output modules if a potential difference U_{ISO} can occur between the reference point of the measuring circuit M_{ANA} and chassis ground. By means of an equipotential bonding conductor between the M_{ANA} terminal and chassis ground, make sure that U_{ISO} does not exceed the permitted value.

5.14 Connecting Loads/Actuators to Voltage Outputs

Connecting Loads to a Voltage Output

Connecting loads to a voltage output is possible both in a four-conductor and a two-conductor connection.

Note

The necessary connecting cables, which result from the potential connection of the analog output module, are not drawn in the figures shown below.

In other words, you must continue to take note of and implement Section 5.13 with its generally applicable information for connecting loads and actuators.

Abbreviations and Mnemonics Used in the Figures Below

The abbreviations and mnemonics used in the figures below have the following meanings:

| | |
|-------------|---|
| Q_V : | Analog output voltage |
| S +: | Detector lead (positive) |
| S –: | Detector lead (negative) |
| M_{ANA} : | Reference potential of analog circuit |
| R_L : | Load impedance |
| L +: | Terminal for 24 VDC supply voltage |
| M : | Ground terminal |
| U_{ISO} : | Potential difference between M_{ANA} and chassis ground |

Four-Conductor Connection of Loads to a Voltage Output

A high accuracy at the load can be achieved through the four-conductor connection. You must therefore connect the sensor leads (S– and S+) directly to the load. The voltage is thus measured and corrected directly at the load.

Problems or a voltage drop can result in a potential difference between the sensor lead S– and the reference circuit of the analog circuit M_{ANA} . This potential difference (U_{CM}) must not exceed the permissible value. If the permissible potential difference is exceeded, the accuracy of the analog signal is impaired.

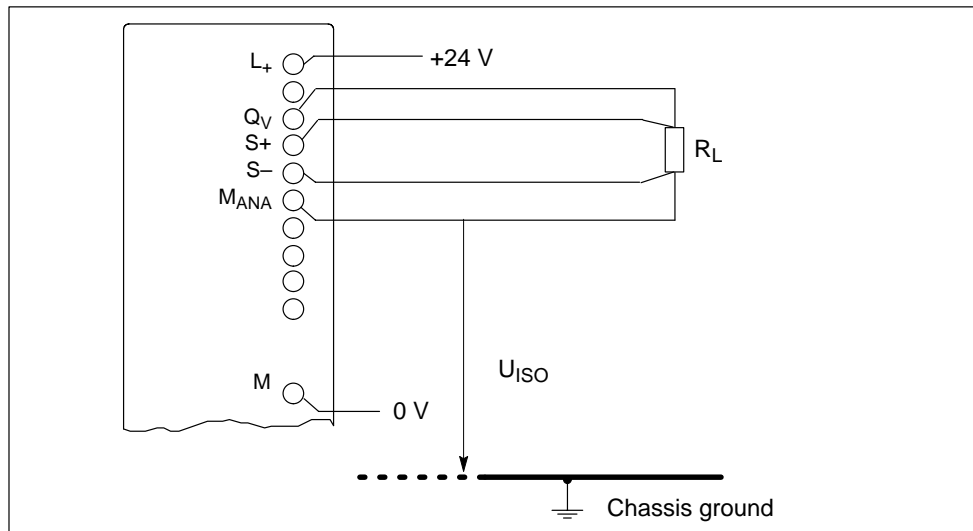

Figure 5-21 Connecting Loads to a Voltage Output of an Isolated AO over a Four-Conductor Connection

Two-Conductor Connection of Loads to a Voltage Output

In the case of a two-conductor connection, connect Q_V to S+ and M_{ANA} to S- on the front connector. However, this will not produce the accuracy of a four-conductor connection.

Connect the load to terminals Q_V and to the reference point of the measuring circuit M_{ANA} of the module.

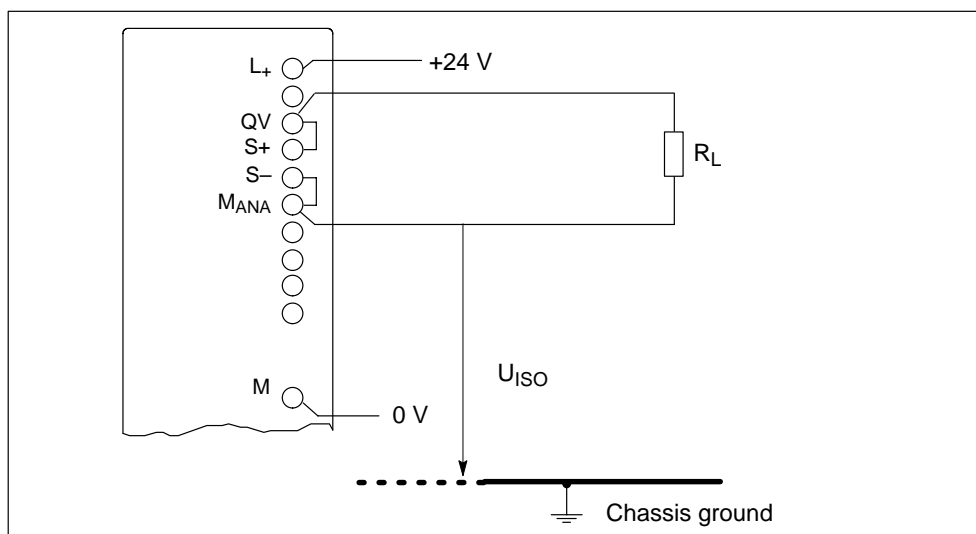

Figure 5-22 Two-Conductor Connection of Loads to a Voltage Output of an Isolated AO

5.15 Connecting Loads/Actuators to Current Outputs

Note

The necessary connecting cables, which result from the potential connection of the analog output module, are not drawn in the figures shown below.

In other words, you must continue to take note of and implement Section 5.13 with its generally applicable information for connecting loads/actuators.

Abbreviations and Mnemonics Used in the Figure Below

The abbreviations and mnemonics used in the figure below have the following meanings:

| | |
|-------------|---|
| Q_i : | Analog output current |
| M_{ANA} : | Reference potential of analog circuit |
| R_L : | Load impedance |
| L +: | Terminal for 24 VDC supply voltage |
| M : | Ground terminal |
| U_{ISO} : | Potential difference between M_{ANA} and chassis ground |

Connecting Loads to a Current Output

You must connect loads to Q_i and the reference point of the analog circuit M_{ANA} of a current output.

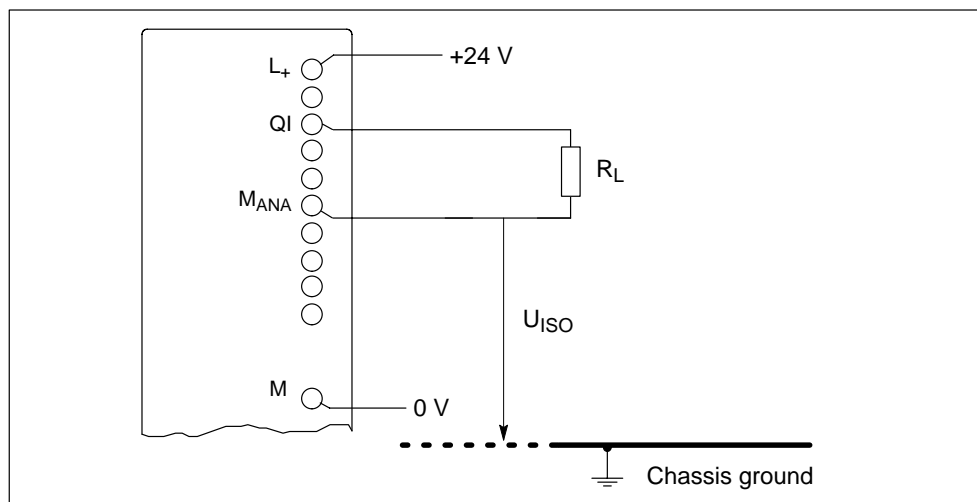

Figure 5-23 Connecting Loads to a Current Output of an Isolated AO

5.16 Diagnostics of the Analog Modules

Programmable and Non-Programmable Diagnostic Messages

In diagnostics, we make a distinction between programmable and non-programmable diagnostic messages.

You obtain programmable diagnostic messages only if you have enabled diagnostics by parameter assignment. You perform parameter assignment in the “Diagnostics” parameter block in *STEP 7* (refer to Section 5.7).

Non-programmable diagnostic messages are always made available by the analog module irrespective of diagnostics being enabled.

Actions Following Diagnostic Messages in *STEP 7*

Each diagnostic message leads to the following actions:

- The diagnostic message is entered in the diagnosis of the analog module, forwarded to the CPU and can be read out by the user program.
- The error LED on the analog module lights.
- If you have enabled diagnostic interrupts in *STEP 7*, a diagnostic interrupt is triggered and OB 82 is called (refer to Section 4.5).

Reading out Diagnostic Messages

You can read out detailed diagnostic messages by means of SFCs in the user program (refer to the Appendix “Diagnostic Data of Signal Modules”).

You can view the cause of the error in *STEP 7* in the module diagnosis (refer to the *STEP 7* online help system).

Diagnostic Message in the Measured Value of Analog Input Modules

Every analog input module supplies the measured value $7FFF_H$ irrespective of the parameter assignment when an error is detected. This measured value means either Overflow, Malfunction or a channel is disabled.

Diagnostic Message via the INTF and EXTF LEDs

Some analog input modules indicate faults by means of their two fault LEDs INTF (internal fault) and EXTF (external fault). The LEDs go out when all the internal and external faults have been eliminated.

Refer to the technical specifications of the modules, starting at Section 5.18, to find out which analog input modules have these fault LEDs.

Diagnostic Messages of the Analog Input Modules

The table below gives an overview of the diagnostic messages for the analog input modules with diagnostics capability.

You can find out which diagnostic messages are possible with which modules in the Appendix entitled “Diagnostic Data of the Signal Modules”.

Table 5-46 Diagnostic Messages of the Analog Input Modules

| Diagnostic Message | LED | Diagnostics Effective for | Parameters Can Be Assigned |
|---|-----------|---------------------------|----------------------------|
| Module problem | INTF/EXTF | Module | No |
| Internal malfunction | INTF | Module | No |
| External malfunction | EXTF | Module | No |
| Channel error present | INTF/EXTF | Module | No |
| External auxiliary supply missing | EXTF | Module | No |
| Front connector missing | EXTF | Module | No |
| Module not parameterized. | INTF | Module | No |
| Wrong parameters | INTF | Module | No |
| Channel information available | INTF/EXTF | Module | No |
| Coding key incorrect or missing | INTF | Module | No |
| Thermocouple connection fault | EXTF | Module | No |
| STOP operating mode | – | Module | No |
| EPROM error | INTF | Module | No |
| RAM error | INTF | Module | No |
| ADC/DAC error | INTF | Module | No |
| Hardware interrupt lost | INTF | Module | No |
| Configuring/parameter assignment error | INTF | Channel | No |
| Short-circuit to M | EXTF | Channel | Yes |
| Wire break | EXTF | Channel | Yes |
| Reference channel error | EXTF | Channel | Yes |
| Underflow | EXTF | Channel | Yes |
| Overflow | EXTF | Channel | Yes |
| User connection not wired | EXTF | Channel | No |
| Open conductor in + direction | EXTF | Channel | No |
| Open conductor in – direction | EXTF | Channel | No |
| Run time calibration error | EXTF | Channel | No |
| Underrange or overrange | EXTF | Channel | No |
| Open conductor in the current source | EXTF | Channel | No |
| User calibration doesn't correspond to the parameter assignment | EXTF | Channel | No |

Note

A prerequisite for detecting the errors indicated by programmable diagnostic messages is that you must have assigned parameters to the analog module accordingly in *STEP 7*.

Causes of Errors and Remedial Measures for Analog Input Modules

Table 5-47 Diagnostics Messages of the Analog Input Modules, Causes of Errors and Remedial Measures

| Diagnostics Message | Possible Error Cause | Remedy |
|---|---|---|
| Module malfunction | An error detected by the module has occurred | - |
| Internal malfunction | The module has detected an error within the programmable controller | - |
| External malfunction | The module has detected an error outside the programmable controller | - |
| There is a channel error | Indicates that only certain channels are faulty | - |
| No external auxiliary voltage | Load voltage to supply the 2-wire transmitter is missing on terminals L+ and M | Feed supply L+ |
| No front connector | Jumper between connections 1 and 2 in the front connector missing | Install jumper |
| Parameters have not been assigned to the module | The module requires the information as to whether it should work with system default parameters or with your parameters | Message queued after power-on until parameter transmission by the CPU has been completed; parameterize the module, as required |
| Wrong parameters | A parameter or combination of parameters is incorrect; impermissible measurement range, for example | Reassign module parameter |
| Channel information available | Channel error present; the module can supply additional channel information | - |
| Measuring range module incorrect/missing | One or more measuring range modules is missing or incorrectly inserted | Insert the measuring range modules on the module according to the parameter assignment of the type of measurement and the measurement range |
| STOP operating mode | Module not parameterized and the first module cycle not completed | If a reboot of the CPU all the digitized analog values are in the intermediate memory, this message is reset |

Table 5-47 Diagnostics Messages of the Analog Input Modules, Causes of Errors and Remedial Measures, continued

| Diagnostics Message | Possible Error Cause | Remedy |
|--|--|---|
| EPROM error | The module is defective | Replace module |
| RAM error | | |
| ADC/DAC error | | |
| Hardware interrupt lost | The module cannot send an interrupt, since the previous interrupt was not acknowledged; configuration error possible | Change interrupt handling in the CPU (change priority for interrupt OB; shorten interrupt program) |
| Configuring/parameter assignment error | Illegal parameters transferred to module | Check measuring range module |
| | | Reassign module parameter |
| Short circuit to M | A short circuit to the M potential has occurred on the sensor supply of two-wire transmitters | Eliminate short circuit |
| Wire break | Resistance too high in the sensor connection | Use different type of sensor or connection, e.g. use conductors with a larger cross-sectional core area |
| | Open circuit between module and sensor | Close circuit |
| | Channel not connected (open) | Disable channel ("Measuring Type" parameter) Connect channel |
| Reference channel error | The reference junction connected at channel 0 is faulty due to a wire break, for example | Check terminals |
| | The reference temperature value transferred is not within the value range | Reparameterize the reference temperature |
| Underflow | Input value violates underrange, error may be caused: Wrong measuring range selected | Configure other measuring range |
| | With the measuring ranges 4 to 20 mA and 1 to 5 V, if necessary by polarity reversal of sensor connection | Check terminals |
| Overflow | Input value overflows overrange | Configure other measuring range |
| Run time calibration error | A wiring fault has occurred on a channel during the calibration cycle | Eliminate the wiring fault (fault remains until the next calibration; in other words, a maximum 6 minutes or until there is a STOP-RUN transition of the CPU) |

5.17 Analog Module Interrupts

Introduction

In this Section, the interrupt behavior of the analog modules is described. The following interrupts exist:

- Diagnostic Interrupt
- Hardware interrupt

Note that not all analog modules have interrupt capability or they are only capable of a subset of the interrupts described here. Refer to the technical specifications of the modules, starting at Section 5.18, to find out which analog modules have interrupt capability.

The OBs and SFCs mentioned below can be found in the online help system for *STEP 7*, where they are described in greater detail.

Enabling Interrupts

The interrupts are not preset – in other words, they are inhibited without appropriate parameter assignment. You enable interrupts in *STEP 7* (refer to Section 5.7).

Special Feature: The Module is Inserted in ER-1/ER-2

Note

If you use the analog module in ER-1/ER-2, you must set the parameters for the input of all the interrupts to “No” because the interrupt lines are not available in ER-1/ER-2.

Diagnostic Interrupt

If you have enabled diagnostic interrupts, then active error events (initial occurrence of the error) and departing error events (message after troubleshooting) are reported by means of an interrupt.

The CPU interrupts the execution of the user program and processes the diagnostic interrupt block (OB 82).

In the user program, you can call SFC 51 or SFC 59 in OB 82 to obtain more detailed diagnostic information from the module.

The diagnostic information is consistent until such time as OB 82 is exited. When OB 82 is exited, the diagnostic interrupt is acknowledged on the module.

Hardware Interrupt with Trigger “Upper or Lower Limit Exceeded”

Define a working range by setting parameters for an upper and lower limit value. If the process signal (for example, the temperature) leaves this working range, the module triggers a hardware interrupt, provided the interrupt is enabled.

The CPU interrupts execution of the user program and processes the hardware interrupt block (OB 40).

In the user program of OB 40, you can set how the programmable controller is required to react to a limit value being surpassed or not being reached.

When OB 40 is exited, the hardware interrupt is acknowledged on the module.

Note

Note that a hardware interrupt is not triggered if you have set the upper limit above the overrange or the lower limit below the underrange.

Structure of the Start Information Tag OB40_POINT_ADDR of OB 40

The limit values exceeded by the different channels are entered in the start information of OB 40 in the tag OB40_POINT_ADDR. The following figure shows the assignment to the bits of local data double word 8.

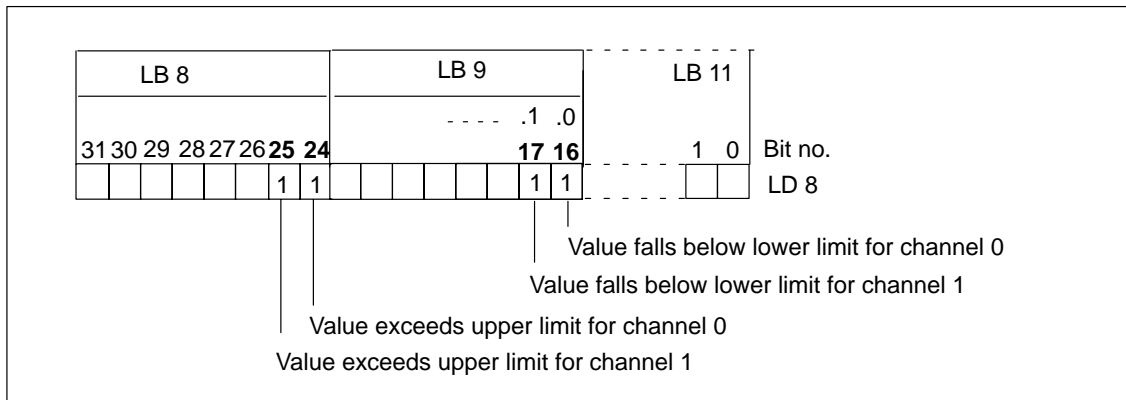

Figure 5-24 Start Information of OB 40: Which Event Triggered the Hardware Interrupt at the Limit Value

Hardware Interrupt on Trigger “Reached End of Scan Cycle”

By parameterizing the hardware interrupt at the end of the scan cycle, you have the option of synchronizing a process with the scan cycle of the analog input module.

A scan cycle includes the conversion of the measured values of all enabled channels of the analog input module. The module processes the channels one after the other. After all the measured values have been converted, the module of the CPU reports by means of an interrupt that there are new measured values on all channels.

You can use the interrupt to load the currently converted analog values.

5.18 Analog Input Module SM 431; AI 8 × 13 Bit; (6ES7431-1KF00-0AB0)

Characteristics

The analog input module SM 431; AI 8 × 13 Bit has the following features:

- 8 inputs for voltage/current measurement
- 4 inputs for resistance measurement
- Unlimited measuring range selection
- 13-bit resolution
- Analog section isolated from CPU
- The maximum permissible common mode voltage between the channels and between the reference potential of the connected sensors and M_{ANA} is 30 VAC

Block Diagram of the SM 431; AI 8 × 13 Bit

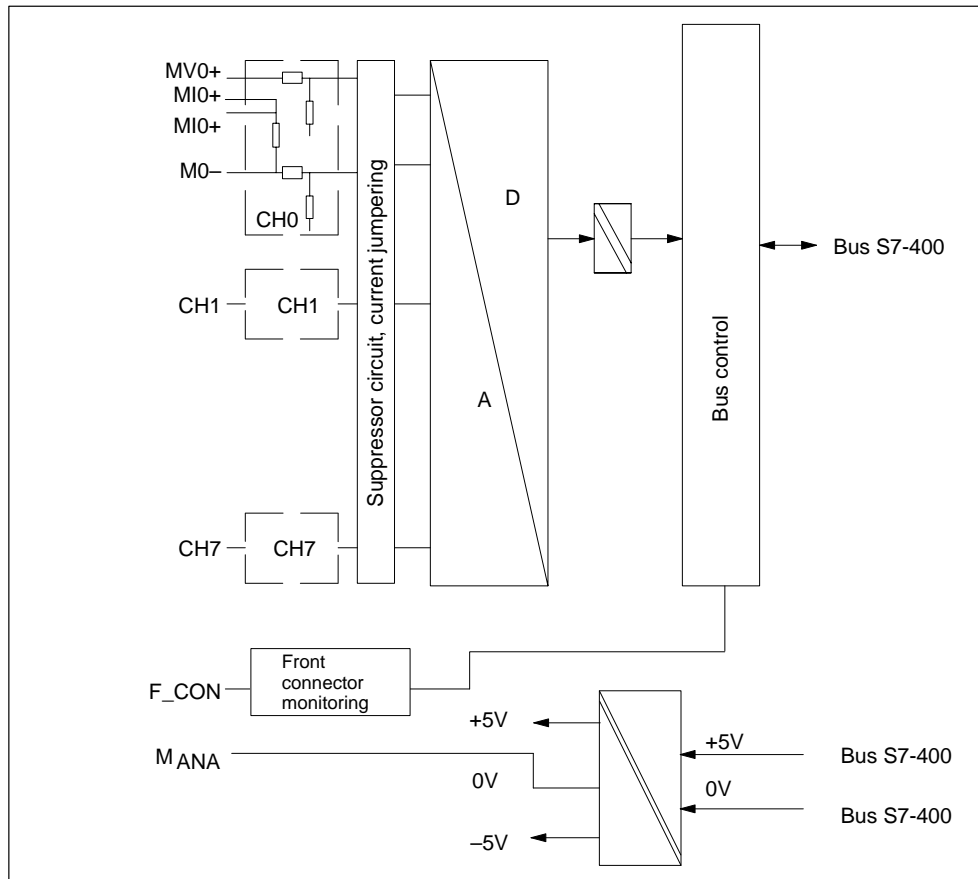

Figure 5-25 Block Diagram of the SM 431; AI 8 x 13 Bit



Warning

The module can be damaged.

The shunt resistor of an input channel can be destroyed if you inadvertently connect a voltage sensor to the M-/MI+ terminals of a channel.

Make sure that the front connector wiring corresponds to the following terminal assignment diagram.

Terminal Assignment Diagram of the SM 431; AI 8 × 13 Bit

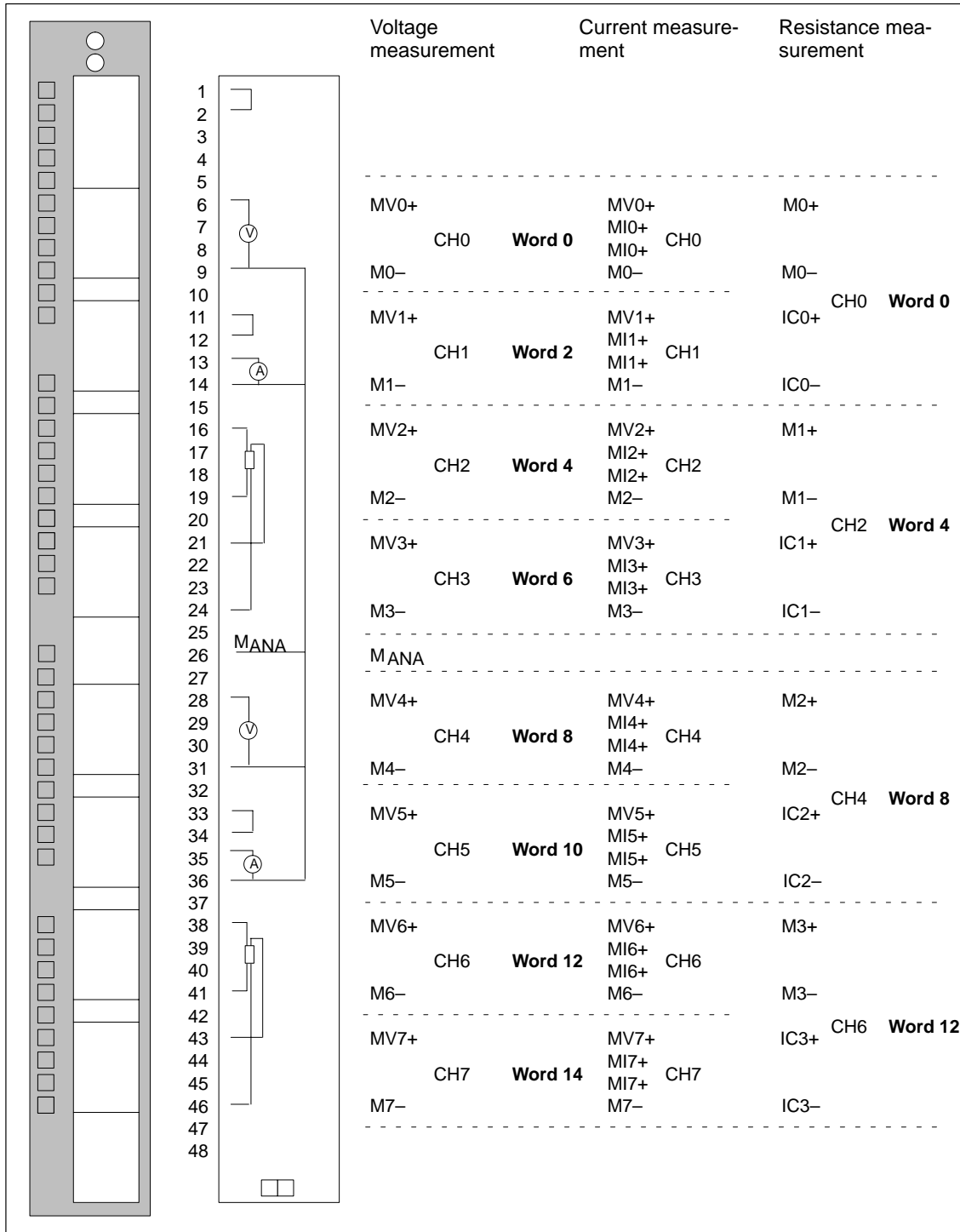

Figure 5-26 Terminal Assignment Diagram of the SM 431; AI 8 x 13 Bit

Technical Specifications of the SM 431; AI 8 × 13 Bit

| Programming package | | Basic execution time of the module, in ms (all channels enabled) | |
|---|--------------------------------------|---|--|
| Associated programming package | As of STEP 7 V 2.0 | 184/200 | |
| Dimensions and Weight | | Suppression of Interference, Limits of Error | |
| Dimensions W × H × D (in millimeters) | 25 × 290 × 210 | Interference voltage suppression for $f = nx$ ($f1 \pm 1\%$), ($f1 =$ interference frequency) $n = 1, 2, \dots$ | |
| Weight | Approx. 500 g | <ul style="list-style-type: none"> Common-mode interference ($U_{CM} < 30$ V) > 100 dB Series-mode interference (peak value of interference < rated value of input range) > 40 dB | |
| Data for Specific Module | | Crosstalk between the inputs > 50 dB | |
| Number of inputs | 8 | Operational limit (in the entire temperature range, with reference to the input range) | |
| • For resistance-type sensor | 4 | <ul style="list-style-type: none"> Voltage input <ul style="list-style-type: none"> – ± 1 V $\pm 1.0\%$ – ± 10 V $\pm 0.6\%$ – 1 V to 5 V $\pm 0.7\%$ Current input <ul style="list-style-type: none"> – ± 20 mA $\pm 1.0\%$ – 4 mA to 20 mA $\pm 1.0\%$ Resistance measurement 0 to 500 Ω; four-conductor measurement (in the range of 600Ω) $\pm 1.25\%$ | |
| Length of cable | | Basic error (operational limit at 25 °5C, referred to input range) | |
| • Shielded | max. 200 m | <ul style="list-style-type: none"> Voltage input <ul style="list-style-type: none"> – ± 1 V $\pm 0.7\%$ – ± 10 V $\pm 0.4\%$ – 1 V to 5 V $\pm 0.5\%$ Current input <ul style="list-style-type: none"> – ± 20 mA $\pm 0.7\%$ – 4 mA to 20 mA $\pm 0.7\%$ Resistance measurement 0 to 500 Ω; four-conductor measurement (in the range of 600Ω) $\pm 0.8\%$ | |
| Voltages, Currents, Potentials | | Temperature error with reference to the input range | |
| Rated load voltage L+ | Not required | <ul style="list-style-type: none"> In the resistance measurement range $\pm 0.02\%$ K In all the other measurement ranges $\pm 0.007\%$ K | |
| Constant measured current for resistance-type sensor | Typ. 1.67 mA | Linearity error (with reference to the input range) $\pm 0.05\%$ K | |
| Isolation | | Repeat accuracy (in the steady state at 25 °C, referred to the input range) $\pm 0.1\%$ | |
| • Between channels and backplane bus | Yes | | |
| • Between the channels | No | | |
| Permitted potential difference | | | |
| • Between inputs and M_{ANA} (U_{CM}) | 30 VAC | | |
| • Between the inputs (E_{CM}) | 30 VAC | | |
| • Between M_{ANA} and $M_{internal}$ (U_{ISO}) | 75 VDC / 60 VAC | | |
| Insulation tested with | | | |
| • Between bus and analog section | 2120 VDC | | |
| • Between bus and chassis ground | 500 VDC | | |
| • Between analog section and chassis ground | 2120 VDC | | |
| Current consumption | | | |
| • From the backplane bus | Max. 350 mA | | |
| Power dissipation of the module | Typ. 1.8 W | | |
| Analog Value Generation | | | |
| Measuring principle | Integrative | | |
| Integration time/conversion time/resolution (per channel) | (Does not go into the response time) | | |
| • Parameters can be assigned | Yes | | |
| • Interference voltage suppression $f1$ in Hz | 60/50 | | |
| • Integration time in milliseconds | 16.7/20 | | |
| • Basic conversion time in ms | 23/25 | | |
| • Resolution including sign | 13/13 Bit | | |
| Smoothing of the measured values | Not possible | | |

| Status, Interrupts, Diagnostics | | Connection of the signal sensors | |
|---|--|----------------------------------|---|
| Interrupts | None | • For measuring voltage | Possible |
| Diagnostic functions | None | • For measuring current | |
| Substitute value can be applied | No | – As two-wire transmitter | Possible; with external transmitter supply |
| Data for Selecting a Sensor | | – As four-wire transmitter | Possible |
| Input range (rated values)/input resistance | | • For measuring resistance | |
| • Voltage | ± 1 V/200 kΩ ± 10 V/200 kΩ 1 V to 5 V/200 kΩ | – With two-conductor terminal | Possible; cable resistance is also measured |
| • Current | ± 20 mA/80 Ω 4 mA to 20 mA/80 Ω | – With three-conductor terminal | |
| • Resistors | 0 to 600 Ω; of use up to 500 Ω | – With four-conductor terminal | Possible |
| Maximum input current for current input (destruction limit) | 40 mA continuous | Characteristic linearization | No |

5.18.1 Commissioning the SM 431; AI 8 × 13 Bit

You set the mode of operation of the SM 431; AI 8 × 13 Bit in *STEP 7*.

Parameters

You will find a description of the general procedure for assigning parameters to analog modules in Section 5.7.

An overview of the parameters that you can set and their default settings are shown in the table below.

Table 5-48 Parameters of the SM 431; AI 8 × 13 Bit

| Parameter | Value Range | Default ¹⁾ | Parameter Type | Scope |
|----------------------------|--|-----------------------|----------------|---------|
| Measurement | | | | |
| • Measuring method | Disabled U Voltage 4DMU Current (4-wire transmitter) 2DMU Current (2-wire transmitter) R-4L Resistance (four-conductor connection) | U | Static | Channel |
| • Measuring range | Refer to Section 5.18.2 for the measuring ranges of the input channels that you can set. | ± 10 V | | |
| • Interference suppression | 60 Hz; 50 Hz | 50 Hz | | |

¹⁾ Only in the CC (central controller) is it possible to start up the analog modules with the default settings.

5.18.2 Measuring Methods and Measuring Ranges of the SM 431; AI 8 × 13 Bit

Measuring Methods

You can set the following measuring methods for the input channels:

- Voltage measurement
- Current measurement
- Resistance test

You perform the setting with the “Measuring Type” parameter in *STEP 7*.

Wiring for Resistance Measurement

The following conditions apply when measuring the resistance with the SM 431; AI 8 x 13 Bit:

Table 5-49 Channels for Resistance Measurement of the SM 431; AI 8 × 13 Bit

| Measuring Type Parameter | Permissible for Channel n | Condition |
|--|---------------------------|--|
| Resistance (four-conductor connection) | 0, 2, 4 or 6 | You must disable the “Measuring Type” parameter for channels n+1 (1, 3, 5, 7). The reason: The connections of channel n+1 are used to supply the resistance that is connected to channel n. |

Unused Channels

Unused channels can usually be left open. You can improve the noise immunity of the module in a measuring environment with serious interference by short-circuiting the channels and connecting to M_{ANA} . Disable the “Measuring Type” parameter for unused channels. In this way you shorten the scan time of the module.

Measuring Ranges

You set the measuring ranges by means of the “Measuring Range” parameter in *STEP 7*.

Table 5-50 Measuring Ranges of the SM 431; AI 8 x 13 Bit

| Method Selected | Measuring Range | Description |
|--|-------------------------------------|--|
| U: Voltage | ± 1 V 1 to 5 V ± 10 V | You will find the digitized analog values in Section 5.3.1 in the voltage measuring range |
| 2DMU: Current (two-wire transmitter) | 4 to 20 mA | You will find the digitized analog values in Section 5.3.1 in the current measuring range |
| 4DMU: Current (four-wire transmitter) | 4 to 20 mA ± 20 mA | You will find the digitized analog values in Section 5.3.1 in the current measuring range |
| R-4L: Resistance (four-conductor connection) | 600 Ω | You will find the digitized analog values in Section 5.3.1 in the resistance measuring range |

Default Settings

The default settings of the module are “Voltage” for the measuring method and “ ± 10 V” for the measuring range. You can use this combination of measuring method and measuring range without parameterizing the SM 431; AI 8 x 13 Bit in *STEP 7*.

5.19 Analog Input Module SM 431; AI 8 × 14 Bit; (6ES7 431-1KF10-0AB0)

Characteristics

The analog input module SM 431; AI 8 × 14 Bit has the following features:

- 8 inputs for voltage/current measurement
- 4 inputs for resistance and temperature measurement
- Unlimited measuring range selection
- 14-bit resolution
- Particularly suitable for measuring temperatures
- Temperature sensor types can be parameterized
- Linearization of the sensor characteristic curves
- Supply voltage 24 VDC required only for the connection of 2-wire transmitters
- Analog section isolated from CPU
- The maximum permissible common mode voltage between the channels and between the channel and the central ground point is 120 VAC

Block Diagram of the SM 431; AI 8 × 14 Bit

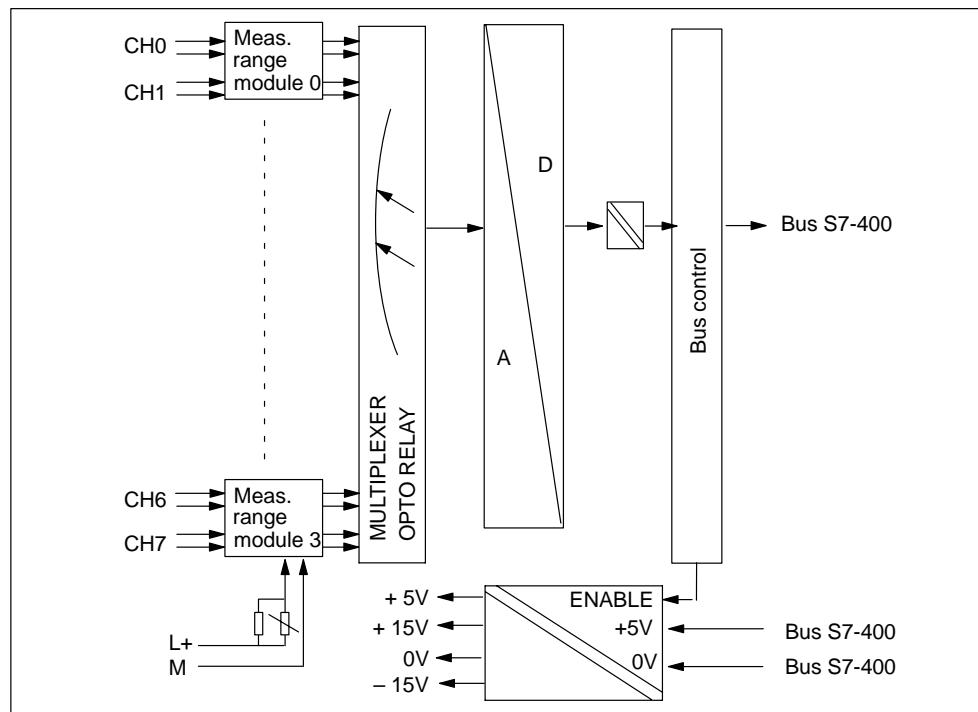

Figure 5-27 Block Diagram of the SM 431; AI 8 x 14 Bit

Terminal Assignment Diagram of the SM 431; AI 8 × 14 Bit

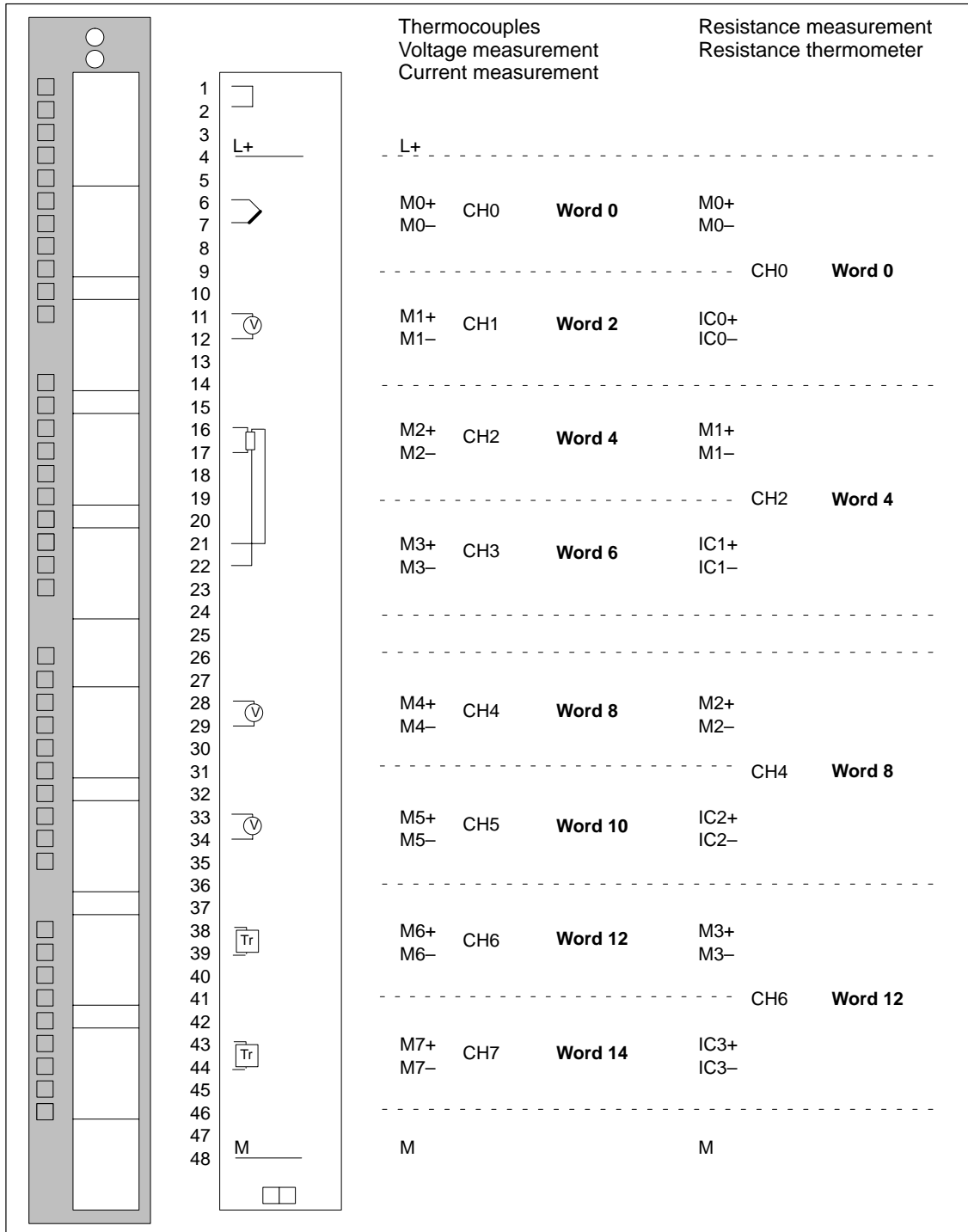

Figure 5-28 Terminal Assignment Diagram of the SM 431; AI 8 x 14 Bit

Technical Specifications of the SM 431; AI 8 × 14 Bit

| Programming package | | Current consumption | |
|---|--|--|---|
| Associated programming package | As of STEP 7 V 2.0 | <ul style="list-style-type: none"> From the backplane bus From the backplane bus L+ | Max. 600 mA Max. 200 mA (with 8 connected, fully controlled two-wire transmitters) |
| Dimensions and Weight | | Power dissipation of the module | |
| Dimensions W × H × D (in millimeters) | 25 × 290 × 210 | | Typ. 3.5 W |
| Weight | Approx. 500 g | Analog Value Generation | |
| Data for Specific Module | | Measuring principle | Integrative |
| Number of inputs | 8 | Integration time/conversion time/resolution (per channel) | (Does not go into the response time) |
| <ul style="list-style-type: none"> For resistance-type sensor | 4 | <ul style="list-style-type: none"> Parameters can be assigned Interference voltage suppression f1 in Hz Integration time in milliseconds Basic conversion time in ms Additional conversion time for measuring resistance in ms Additional conversion time for open-circuit monitoring in ms Additional conversion time for measuring resistance in ms Resolution including sign <ul style="list-style-type: none"> Smoothing activated | Yes 60/50 16.7/20 20.1/23.5 40.2/47 4.3/4.3 5.5/5.5 14/14 bit 16/16 bit |
| Length of cable | | Smoothing of the measured values | Parameters can be assigned in 4 stages |
| <ul style="list-style-type: none"> Shielded in the 80 mV input range and with thermocouples | Max. 200 m Max. 50 m | Basic execution time of the module, in ms (all channels enabled) | 161/188 |
| Voltages, Currents, Potentials | | | |
| Rated load voltage L+ | 24 VDC (required only for the supply of two-wire transmitters) | | |
| <ul style="list-style-type: none"> Reverse polarity protection | Yes | | |
| Power supply of the transmitters | | | |
| <ul style="list-style-type: none"> Supply current Short-circuit proof | max. 50 mA Yes Typ. 1.67 mA | | |
| Constant measured current for resistance-type sensor | | | |
| Isolation | | | |
| <ul style="list-style-type: none"> Between channels and backplane bus Between the channels Between channels and load voltage L+ | Yes No Yes | | |
| Permitted potential difference | | | |
| <ul style="list-style-type: none"> Between inputs and M_{ANA} (U_{CM}) Between the inputs (E_{CM}) Between M_{ANA} and $M_{internal}$ (U_{ISO}) | 120 VAC 120 VAC 75 VDC / 60 VAC | | |
| Insulation tested with | | | |
| <ul style="list-style-type: none"> Between bus and L+/M Between bus and analog section Between bus and chassis ground Between analog section and L+/M Between analog section and chassis ground Between L+/M and chassis ground | 2120 VDC 2120 VDC 500 VDC 707 VDC 2120 VDC 2120 VDC | | |

| Suppression of Interference, Limits of Error | |
|--|--------------|
| Interference voltage suppression for $f = nx$ ($f1 \pm 1\%$), ($f1 =$ interference frequency) $n = 1, 2, \dots$ | |
| • Common-mode interference ($U_{CM} < 120 V_{SS}$) | > 100 dB |
| • Series-mode interference (peak value of interference < rated value of input range) | > 40 dB |
| Crosstalk between the inputs | >70 dB |
| Operational limit (in the entire temperature range, with reference to the input range) | |
| • Voltage input | |
| – ± 80 mV | $\pm 0.38\%$ |
| – ± 250 mV | $\pm 0.35\%$ |
| – ± 500 mV | $\pm 0.35\%$ |
| – ± 1 V | $\pm 0.35\%$ |
| – ± 2.5 V | $\pm 0.35\%$ |
| – ± 5 V | $\pm 0.35\%$ |
| – 1 V to 5 V | $\pm 0.35\%$ |
| – ± 10 V | $\pm 0.35\%$ |
| • Current input | |
| – 0 ... 20 mA | $\pm 0.35\%$ |
| – ± 20 mA | $\pm 0.35\%$ |
| – 4 mA to 20 mA | $\pm 0.35\%$ |
| • Resistance test | |
| – 0 to 48 Ω ; four-conductor measurement | $\pm 0.35\%$ |
| – 0 to 150 Ω ; four-conductor measurement | $\pm 0.35\%$ |
| – 0 to 300 Ω ; four-conductor measurement | $\pm 0.35\%$ |
| – 0 to 600 Ω ; four-conductor measurement | $\pm 0.35\%$ |
| – 0 to 5000 Ω ; four-conductor measurement (in the range of 6000 Ω) | $\pm 0.35\%$ |
| – 0 to 300 Ω ; three-conductor measurement | $\pm 0.5\%$ |
| – 0 to 600 Ω ; three-conductor measurement | $\pm 0.5\%$ |
| – 0 to 5000 Ω ; three-conductor measurement (in the range of 6000 Ω) | $\pm 0.5\%$ |
| • Thermocouples | |
| – TC type B | ± 14.8 K |
| – TC type R | ± 9.4 K |
| – TC type S | ± 10.6 K |
| – TC type T | ± 2.2 K |
| – TC type E | ± 4.0 K |
| – TC type J | ± 5.2 K |
| – TC type K | ± 7.6 K |
| – TC type U | ± 3.5 K |
| – TC type L | ± 5.1 K |
| – TC type N | ± 5.5 K |
| • Resistance thermocouples, four-conductor standard measuring range | |
| – Pt 100 | ± 4.6 K |
| – Pt 200 | ± 5.7 K |
| – Pt 500 | ± 4.6 K |
| – Pt 1000 | ± 3.7 K |
| – Ni 100 | ± 0.9 K |
| – Ni 1000 | ± 0.9 K |
| Climatic measuring range | |
| – Pt 100 | ± 0.5 K |
| – Pt 200 | ± 0.5 K |
| – Pt 500 | ± 0.5 K |
| – Pt 1000 | ± 0.5 K |
| – Ni 100 | ± 0.9 K |
| – Ni 1000 | ± 0.9 K |
| • Resistance thermocouples, three-conductor standard measuring range | |
| – Pt 100 | ± 5.2 K |
| – Pt 200 | ± 8.2 K |
| – Pt 500 | ± 6.5 K |
| – Pt 1000 | ± 5.2 K |
| – Ni 100 | ± 1.3 K |
| – Ni 1000 | ± 1.3 K |
| Climatic measuring range | |
| – Pt 100 | ± 0.7 K |
| – Pt 200 | ± 0.7 K |
| – Pt 500 | ± 0.7 K |
| – Pt 1000 | ± 0.7 K |
| – Ni 100 | ± 1.3 K |
| – Ni 1000 | ± 1.3 K |

| | | | |
|--|--|--|--|
| Basic error (operational limit at 25 °C, referred to input range) | | <ul style="list-style-type: none"> Resistance thermocouples, four-conductor standard measuring range <ul style="list-style-type: none"> Pt 100 ± 2.0 K Pt 200 ± 2.5 K Pt 500 ± 2.0 K Pt 1000 ± 1.6 K Ni 100 ± 0.4 K Ni 1000 ± 0.4 K Climatic measuring range <ul style="list-style-type: none"> Pt 100 ± 0.2 K Pt 200 ± 0.2 K Pt 500 ± 0.2 K Pt 1000 ± 0.2 K Ni 100 ± 0.4 K Ni 1000 ± 0.4 K Resistance thermocouples, three-conductor standard measuring range <ul style="list-style-type: none"> Pt 100 ± 3.1 K Pt 200 ± 4.9 K Pt 500 ± 3.9 K Pt 1000 ± 3.1 K Ni 100 ± 0.8 K Ni 1000 ± 0.8 K Climatic measuring range <ul style="list-style-type: none"> Pt 100 ± 0.4 K Pt 200 ± 0.4 K Pt 500 ± 0.4 K Pt 1000 ± 0.4 K Ni 100 ± 0.8 K Ni 1000 ± 0.8 K Temperature error (with reference to the input range) ± 0.004% K Linearity error (with reference to the input range) ± 0.01% K Repeat accuracy (in the steady state at 25 °C, referred to the input range) ± 0.1% | |
| <ul style="list-style-type: none"> Voltage input <ul style="list-style-type: none"> ± 80 mV ± 0.17% ± 250 mV ± 0.15% ± 500 mV ± 0.15% ± 1 V ± 0.15% ± 2.5 V ± 0.15% ± 5 V ± 0.15% 1 V to 5 V ± 0.15% ± 10 V ± 0.15% Current input <ul style="list-style-type: none"> 0 mA to 20 mA ± 0.15% ± 20 mA ± 0.15% 4 ... 20 mA ± 0.15% Resistance test <ul style="list-style-type: none"> 0 to 48 Ω; four-conductor measurement ± 0.15% 0 to 150 Ω; four-conductor measurement ± 0.15% 0 to 300 Ω; four-conductor measurement ± 0.15% 0 to 600 Ω; four-conductor measurement ± 0.15% 0 to 5000 Ω; four-conductor measurement (in the range of 6000 Ω) ± 0.15% 0 to 300 Ω; three-conductor measurement ± 0.3% 0 to 600 Ω; three-conductor measurement ± 0.3% 0 to 5000 Ω; three-conductor measurement (in the range of 6000 Ω) ± 0.3% Thermocouples <ul style="list-style-type: none"> TC type B ± 8.2 K TC type R ± 5.2 K TC type S ± 5.9 K TC type T ± 1.2 K TC type E ± 1.8 K TC type J ± 2.3 K TC type K ± 3.4 K TC type U ± 1.8 K TC type L ± 2.3 K TC type N ± 2.9 K | | | |

| Status, Interrupts, Diagnostics | |
|---|--|
| Interrupts | None |
| Diagnostic functions | None |
| Substitute value can be applied | No |
| Data for Selecting a Sensor | |
| Input range (rated values)/Input resistance | |
| • Voltage | ± 80 mV/1 MΩ ± 250 mV/1 MΩ ± 500 mV/1 MΩ ± 1 V/1 MΩ ± 2.5 V/1 MΩ ± 5 V/1 MΩ 1 to 5 V/1 MΩ ± 10 V/1 MΩ |
| • Current | 0 to 20 mA/50 Ω ± 20 mA/50 Ω 4 to 20 mA/50 Ω |
| • Resistors | 0 to 48 Ω/1 MΩ 0 to 150 Ω/1 MΩ 0 to 300 Ω/1 MΩ 0 to 600 Ω/1 MΩ 0 to 6000 Ω/1 MΩ (can be used up to 5000 Ω) |
| • Thermocouples | TC type B/1 MΩ TC type R/1 MΩ TC type S/1 MΩ TC type T/1 MΩ TC type E/1 MΩ TC type J/1 MΩ TC type K/1 MΩ TC type U/1 MΩ TC type L/1 MΩ TC type N/1 MΩ |
| • Resistance thermometer | Pt 100/1 MΩ Pt 200/1 MΩ Pt 500/1 MΩ Pt 1000/1 MΩ Ni 100/1 MΩ Ni 1000/1 MΩ |
| Maximum input voltage for voltage input (destruction limit) | Max. 18 V continuous 75 V for 1 ms (cycle factor 1 : 20) |
| Maximum input current for current input (destruction limit) | 40 mA continuous |
| Connection of the sensor | |
| • For measuring voltage | Possible |
| • For measuring current | |
| – As two-wire transmitter | Possible |
| – As four-wire transmitter | Possible |
| • For measuring resistance | |
| – With two-conductor terminal | Possible; cable resistance is also measured |
| – With three-conductor terminal | Possible |
| – With four-conductor terminal | Possible |
| • Load of the two-wire transmitter | Max. 750 Ω |
| Characteristic linearization | Parameters can be assigned |
| • For thermocouples | Types B, R, S, T, E, J, K, U, L, N |
| • For resistance thermometers | Pt 100, Pt 200, Pt 500, Pt 1000, Ni 100, Ni 1000 |
| Temperature compensation | Yes, programmable |
| • Internal temperature compensation | No |
| • External temperature compensation with compensating box | Possible |
| • External temperature compensation with Pt 100 | Possible |
| • Compensation for definable reference junction temperature | Possible |
| Unit for temperature measurement | Degrees Celsius |

5.19.1 Commissioning the SM 431; AI 8 × 14 Bit

You set the mode of operation of the SM 431; AI 8 × 14 Bit by means of measuring range modules on the module and in *STEP 7*.

Measuring Range Module

A measuring range module of the module matches two channels and one resistance channel to each type of sensor. If necessary, the measuring range modules must be replugged to change the measuring method and the measuring range. The steps you have to perform to do this are described in detail in Section 5.4.

The corresponding table in Section 5.19.2 tells you which assignment you have to select for which measuring method and measuring range. In addition, the necessary settings are embossed on the module.

Parameter

You will find a description of the general procedure for assigning parameters to analog modules in Section 5.7.

An overview of the parameters that you can set and their default settings are shown in the table below.

Table 5-51 Parameters of the SM 431; AI 8 × 14 Bit

| Parameter | Value Range | Default ¹ | Parameter Type | Scope |
|--|--|----------------------|----------------|---------|
| Diagnostics • Wire break | Yes/no | No | Static | Channel |
| Measurement • Measuring type • Measuring range | Disabled U Voltage 4DMU Current (four-wire transmitter) 2DMU Current (two-wire transmitter) R-4L Resistance (four-conductor terminal) R-3L Resistance (three-conductor terminal) RTD-4L Thermal resistor (linear, four-conductor terminal) RTD-3L Thermal resistor (linear, three-conductor terminal) TC-L Thermocouple (linear) | U | Static | Channel |
| • Reference Temperature | – 273.15 to 327.67 °C | 0,00 °C | Dynamic | Module |

Table 5-51 Parameters of the SM 431; AI 8 × 14 Bit, continued

| Parameter | Value Range | Default ¹ | Parameter Type | Scope |
|----------------------------|---|----------------------|----------------|---------|
| • Interference suppression | 60 Hz; 50 Hz | 50 Hz | Static | Channel |
| • Smoothing | None Low Average High | None | Static | Channel |
| • Ref. junction | None RTD on Channel 0 Reference temperature value dynamic | None | | |

¹ Only in the CC (central controller) is it possible to start up the analog modules with the default settings.

Smoothing of the Measured Values

You will find information that is generally applicable to the smoothing of analog values in Section 5.6.

The following figure indicates for the module in the case of a step response the number of module cycles after which the smoothed analog value applies at almost 100%, depending on the smoothing setting. The figure applies to every change of signal at an analog input.

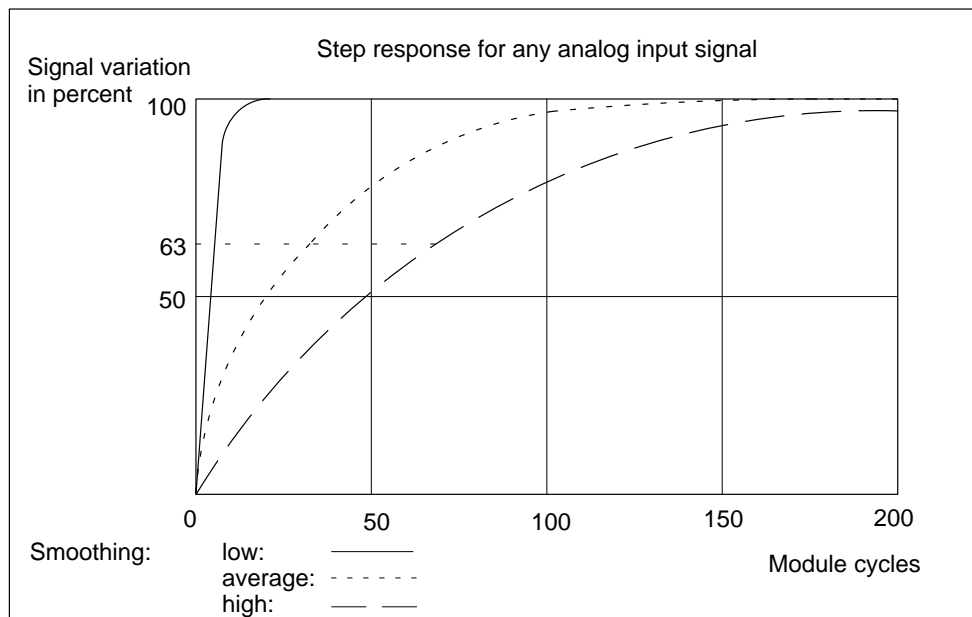

Figure 5-29 Step Response of the SM 431; AI 8 × 14 Bit

5.19.2 Measuring Methods and Measuring Ranges of the SM 431; AI 8 × 14 Bit

Measuring Methods

You can set the following measuring methods for the input channels:

- Voltage measurement
- Current measurement
- Resistance test
- Temperature measurement

You specify the setting by means of the measuring range modules on the module and by means of the “Measuring Type” parameter in *STEP 7*.

Circuit Variants for the Channels

Two channels are set in each case with the measuring range module. There are therefore restrictions as regards the measuring method for the adjacent channels 0/1, 2/3, 4/5 and 6/7, as shown in the following table:

Table 5-52 Selection of the Measuring Method for Channel n and Channel n+1 of the SM 431; AI 8 × 14 Bit

| Meas. Method Chan. n+1 / Meas. Method Channel n | Dis- abled | Voltage | Current 4-DMU | Current 2-DMU | R-4L | R-3L | RTD-4L | RTD-3L | TC-L |
|--|---------------|---------|------------------|------------------|------|------|--------|--------|------|
| Disabled | x | x | x | x | | | | | x |
| Voltage | x | x | | | | | | | x |
| Current four-wire transmitter | x | | x | | | | | | |
| Current two-wire transmitter | x | | | x | | | | | |
| Resistor four-conductor | x | | | | | | | | |
| Resistor three-conductor | x | | | | | | | | |
| Thermal resistor four-conductor | x | | | | | | | | |
| Thermal resistor three-conductor | x | | | | | | | | |
| Thermocouples | x | x | | | | | | | x |

Example

If you select “current (two-wire transmitter)” for channel 6, you can then only deactivate the measuring method or set “current (two-wire transmitter)” for channel 7.

Wiring for Resistance and Temperature Measurement

The following conditions apply when measuring the resistance and temperature with the SM 431; AI 8 x 14 Bit:

Table 5-53 Channels for Resistance and Temperature Measurement with the SM 431; AI 8 × 14 Bit

| Measuring Type Parameter | Permissible for Channel n | Condition |
|--|---------------------------|--|
| Resistor (four-conductor terminal) | 0, 2, 4 or 6 | You must disable the "Measuring Type" parameter for channels n+1 (1, 3, 5, 7). The reason: The connections of channel n+1 are used to supply the resistance that is connected to channel n. |
| Resistor (three-conductor terminal) | 0, 2, 4 or 6 | |
| Thermal resistor (linear, four-conductor terminal) | 0, 2, 4 or 6 | |
| Thermal resistor (linear, four-conductor terminal) | 0, 2, 4 or 6 | |

Wiring for Junction Compensation for Thermocouples

If you select "RTD on Channel 0" as a reference junction for reference junction compensation for thermocouples, the following applies:

Table 5-54 Thermocouple with Reference Junction Compensation via RTD on Channel 0

| Reference Junction Parameter | Permissible for Channel n | Condition |
|------------------------------|---------------------------|---|
| RTD on Channel 0 | 2 to 7 | You must connect and parameterize on channel 0 a resistance thermometer with linearization, a 3- or 4- conductor connection in the climatic range (channels 0 and 1 are thus assigned). The reason: If channel 0 is to be used as the reference junction, a resistance-type sensor must be connected there to record absolute temperatures in the climatic range. |

Unused Channels

Unused channels can usually be left open. Put the measuring range module in position "A". You can improve the noise immunity of the module in a measuring environment with serious interference by short-circuiting the channels.

Disable the "Measuring Type" parameter for unused channels. In this way you shorten the scan time of the module.

Measuring Ranges

You set the measuring ranges by means of the measuring range modules on the module and the “Measuring Type” parameter in *STEP 7*.

Table 5-55 Measuring Ranges of the SM 431; AI 8 x 14 Bit

| Method Selected | Measuring Range (Type of Sensor) | Measuring Range Module Setting | Description |
|--|--|--------------------------------|---|
| U: Voltage | ± 80 mV ± 250 mV ± 500 mV ± 1 V ± 2.5 V ± 5 V 1 to 5 V ± 10 V | A | You will find the digitized analog values in Section 5.3.1 in the voltage measuring range |
| 2DMU: Current (two-wire transmitter) | 4 to 20 mA | D | To supply these transmitters with current you must connect 24 V to the L+ and M front connector terminals. You will find the digitized analog values in Section 5.3.1 in the current measuring range |
| 4DMU: Current (four-wire transmitter) | 0 to 20 mA 4 to 20 mA ± 20 mA | C | You will find the digitized analog values in Section 5.3.1 in the current measuring range |
| R-4L: Resistors (four-conductor connection) | 48 Ω 150 Ω 300 Ω 600 Ω 6000 Ω | A | You will find the digitized analog values in Section 5.3.1 in the resistance measuring range |
| R-3L: Resistors (three-conductor connection) | 300 Ω 600 Ω 6000 Ω | | |

Table 5-55 Measuring Ranges of the SM 431; AI 8 x 14 Bit, continued

| Method Selected | Measuring Range (Type of Sensor) | Measuring Range Module Setting | Description |
|---|--|--------------------------------|---|
| TC-L: Thermocouple (linear) (temperature measurement) | Type B Type N Type E Type R Type S Type J Type L Type T Type K Type U | A | You will find the digitized analog values in Section 5.3.1 in the temperature range |
| RTD-4L: thermal resistor (linear, four-conductor connection) (temperature measurement) | Pt 100 climatic Pt 200 climatic Pt 500 climatic Pt 1000 climatic Ni 100 climatic Ni 1000 climatic | A | |
| RTD-3L: thermal resistor (linear, three-conductor connection) (temperature measurement) | Pt 100 standard Pt 200 standard Pt 500 standard Pt 1000 standard Ni 100 standard Ni 1000 standard | | |

Default Settings

The module has the following default settings in *STEP 7*:

- Channels 0 to 7: “Voltage” for the measuring method ; “± 10 V” for the measuring range

You can use these measuring methods and measuring ranges without parameterizing the SM 431; AI 8 × 14 Bit in *STEP 7*.

Wire Break Check for Temperature or Resistance Measurement

The wire break check is intended primarily for temperature measurements (TC, RTD) or resistance measurements. Always parameterize the wire break check in these cases as this ensures that, in the event of a wire break, the measured value provided by the module accepts the data for overrun 7FFFH.

Special Characteristics of the Wire Break Check for the Voltage Measurement Methods

In some transmitters, incorrect measured values may be obtained due to the fact that the wire break check is enabled. If so, disable the wire break check.

The reason Some transmitters try to correct the test current and in doing so corrupt the setpoint value provided.

5.20 Analog Input Module SM 431; AI 8 × 14 Bit; (6ES7431-1KF20-0AB0)

Characteristics

The analog input module SM 431; AI 8 × 14 Bit has the following features:

- Rapid A/D changeover, therefore particularly suitable for highly dynamic processes
- 8 inputs for voltage/current measurement
- 4 inputs for resistance measurement
- Unlimited measuring range selection
- 14-bit resolution
- Supply voltage: 24 VDC required only for the connection of 2-wire transmitters
- Analog section isolated from CPU
- The maximum permissible common mode voltage between the channels and between the reference potential of the connected sensors and M_{ANA} is 8 VAC

Block Diagram of the SM 431; AI 8 × 14 Bit

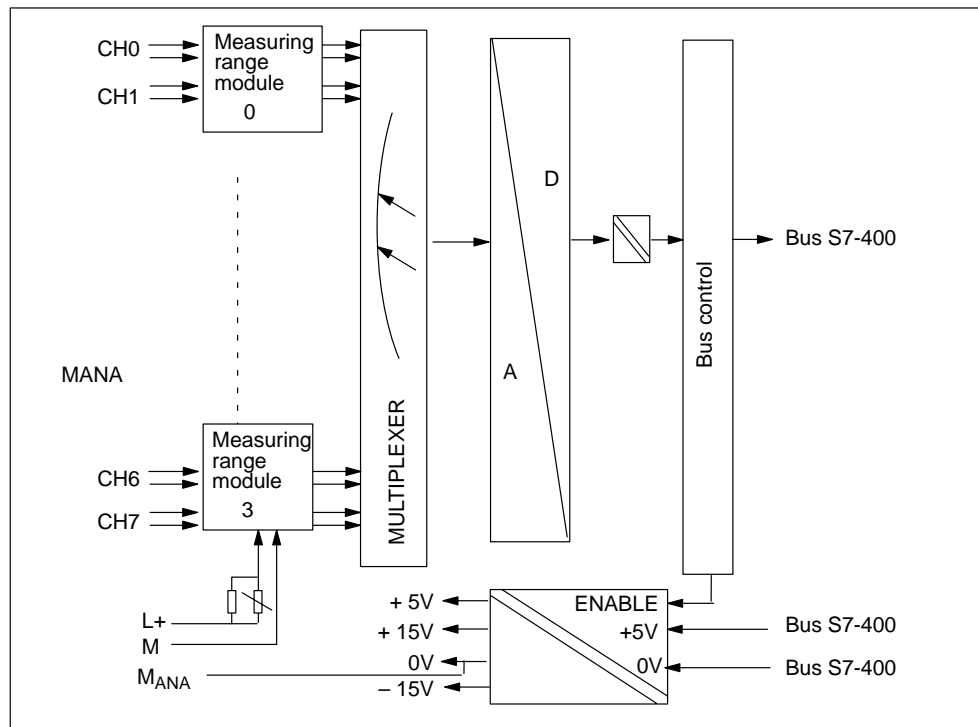

Figure 5-30 Block Diagram of the SM 431; AI 8 x 14 Bit

Terminal Assignment Diagram of the SM 431; AI 8 × 14 Bit

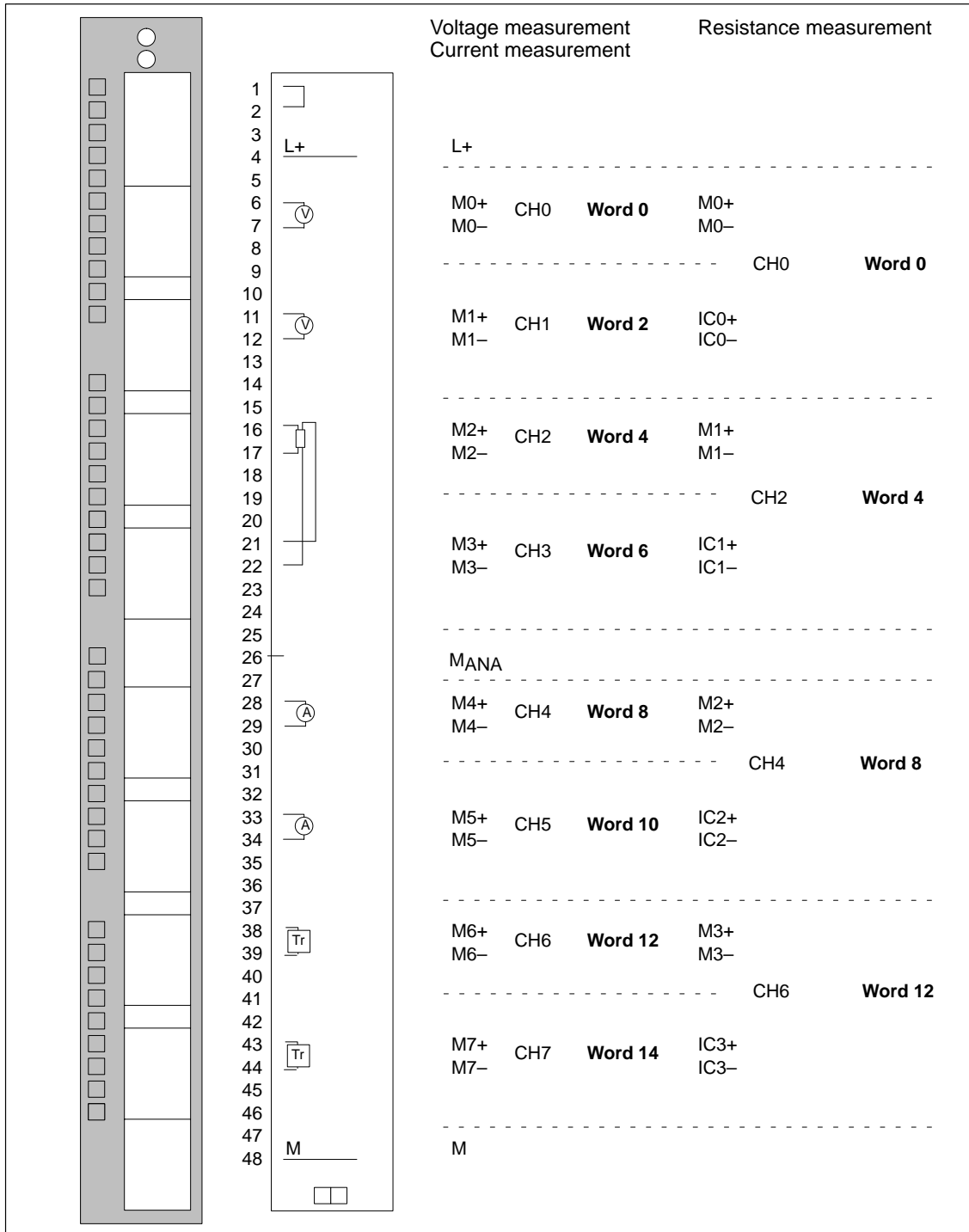

Figure 5-31 Terminal Assignment Diagram of the SM 431; AI 8 x 14 Bit

Technical Specifications of the SM 431; AI 8 × 14 Bit

| Programming package | |
|--|--|
| Associated programming package | As of STEP 7 V 2.0 |
| Dimensions and Weight | |
| Dimensions W × H × D (in millimeters) | 25 × 290 × 210 |
| Weight | Approx. 500 g |
| Data for Specific Module | |
| Number of inputs | 8 |
| • For resistance-type sensor | 4 |
| Length of cable | |
| • Shielded | Max. 200 m |
| Voltages, Currents, Potentials | |
| Rated load voltage L+ | 24 VDC (required only for the supply of 2-wire transmitters) |
| • Reverse polarity protection | Yes |
| Power supply of the transmitters | |
| • Supply current | Max. 50 mA |
| • Short-circuit proof | Yes |
| Constant measured current for resistance-type sensor | Typ. 1.67 mA |
| Isolation | |
| • Between channels and backplane bus | Yes |
| • Between the channels | No |
| • Between channels and load voltage L+ | Yes |
| Permitted potential difference | |
| • Between inputs and M _{ANA} (U _{CM}) | 8 VAC |
| • Between the inputs (E _{CM}) | 8 VAC |
| • Between M _{ANA} and M _{internal} (U _{ISO}) | 75 VDC/60 VAC |
| Insulation tested | |
| • Between bus and analog section | 2120 VDC |
| • Between bus and chassis ground | 500 VDC |
| • Between analog section and L+/M | 707 VDC |
| • Between analog section and chassis ground | 2120 VDC |
| • Between L+/M and chassis ground | 2120 VDC |
| Current consumption | |
| • From the backplane bus | Max. 1000 mA |
| • From the backplane bus L+ | Max. 200 mA (with 8 connected, fully controlled 2-wire transmitters) |
| Power dissipation of the module | Typ. 4.9 W |
| Analog Value Generation | |
| Measuring principle | Actual-value conversion |
| Integration time/conversion time/resolution (per channel) | (Does not go into the response time) |
| • Parameters can be assigned | Yes |
| • Interference voltage suppression f1 in Hz | None/400/60/50 |
| • Basic conversion time in ms | 52 μs |
| • Resolution (incl. overrange) | 14/14/14 |
| Smoothing of the measured values | Can be parameterized "none – a lot" |
| Time constant of the input filter | 15 μs |
| Basic execution time of the module, in ms (all channels enabled) | 0.420 |

| Suppression of interference, Limits of Error | Data for Selecting a Sensor |
|--|--|
| <p>Interference voltage suppression parameterized for $f = n \times (f_1 \pm 1\%)$, ($f_1 =$ interference frequency) $n = 1, 2, \dots$ filter 400/60/50 Hz</p> <ul style="list-style-type: none"> • Common-mode interference ($U_{CM} < 11 V_{SS}$) > 80 db • Series-mode interference (peak value of interference < rated value of input range) > 40 dB <p>Crosstalk between the inputs > 70 dB</p> <p>Operational limit (in the entire temperature range, with reference to the input range)</p> <ul style="list-style-type: none"> • Voltage input <ul style="list-style-type: none"> – $\pm 1 V$ $\pm 0.7\%$ – $\pm 10 V$ $\pm 0.9\%$ – 1 V to 5 V $\pm 0.9\%$ • Current input <ul style="list-style-type: none"> – $\pm 20 mA$ $\pm 0.8\%$ – 4 mA to 20 mA $\pm 0.8\%$ • Resistance test <ul style="list-style-type: none"> – 0...600 Ω; $\pm 1.0\%$ <p>Basic error (operational limit at 25°C, referred to input range)</p> <ul style="list-style-type: none"> • Voltage input <ul style="list-style-type: none"> – $\pm 1 V$ $\pm 0.6\%$ – $\pm 10 V$ $\pm 0.75\%$ – 1 ... 5 V $\pm 0.75\%$ • Current input <ul style="list-style-type: none"> – $\pm 20 mA$ $\pm 0.7\%$ – 4 mA to 20 mA $\pm 0.7\%$ • Resistance test <ul style="list-style-type: none"> – 0 to 600 Ω; $\pm 0.7\%$ <p>Temperature error (with reference to the input range) $\pm 0,03\% K$</p> <p>Linearity error (with reference to the input range) $\pm 0,05\% K$</p> <p>Repeat accuracy (in the steady state at 25 °C, referred to the input range) $\pm 0.2\%$</p> | <p>Input range (rated values)/Input resistance</p> <ul style="list-style-type: none"> • Voltage $\pm 1 V/10 M\Omega$ $\pm 10 V/10 M\Omega$ 1 V to 5 V/10 MΩ • Current $\pm 20 mA/50 \Omega$ 4 mA to 20 mA/50 Ω • Resistors 0 to 600 $\Omega/10 M\Omega$ <p>Maximum input voltage for voltage input (destruction limit) Max. 18 V continuous; 75 V for 1 ms (cycle factor 1 : 20)</p> <p>Maximum input current for current input (destruction limit) 40 mA continuous</p> <p>Connection of the signal sensor</p> <ul style="list-style-type: none"> • For measuring voltage Possible • For measuring current <ul style="list-style-type: none"> – As two-wire transmitter Possible – As four-wire transmitter Possible • For measuring resistance <ul style="list-style-type: none"> – With two-conductor terminal Possible; cable resistance is also measured – With three-conductor terminal – With four-conductor terminal Possible • Load of the two-wire transmitter Max. 750 Ω <p>Characteristic linearization No</p> |
| Status, Interrupts, Diagnostics | |
| Interrupts | None |
| Diagnostic functions | None |
| Substitute value can be applied | No |

5.20.1 Commissioning the SM 431; AI 8 × 14 Bit

You set the mode of operation of the SM 431; AI 8 × 14 Bit by means of measuring range modules on the module and in *STEP 7*.

Measuring Range Modules

A measuring range module of the module matches two channels and one resistance channel to each type of sensor. If necessary, the measuring range modules must be replugged to change the measuring method and the measuring range. The steps you have to perform to do this are described in detail in Section 5.4.

The corresponding table in Section 5.20.2 tells you which assignment you have to select for which measuring method and measuring range. In addition, the necessary settings are embossed on the module.

Parameters

You will find a description of the general procedure for assigning parameters to analog modules in Section 5.7.

An overview of the parameters that you can set and their default settings are shown in the table below.

Table 5-56 Parameters of the SM 431; AI 8 × 14 Bit (6ES7431-1KF20-0AB0)

| Parameter | Value Range | Default ¹⁾ | Parameter Type | Scope |
|---------------------------------|---|-----------------------|----------------|---------|
| Measurement • Measuring type | Disabled U Voltage 4DMU Current (four-wire transmitter) 2DMU Current (two-wire transmitter) R-4L Resistance (four-conductor terminal) | U | Static | Channel |
| • Measuring range | Refer to Section 5.20.2 for the measuring ranges of the input channels that you can set. | ± 10 V | | |
| • Interference suppression | 400 Hz; 60 Hz; 50 Hz; none | 50 Hz | | |
| • Smoothing | None High | None | | |

¹⁾ Only in the CC (central controller) is it possible to start up the analog modules with the default settings.

Smoothing of the Measured Values

You will find information that is generally applicable to the smoothing of analog values in Section 5.6. You can only set strong smoothing for the SM 431; AI 8 × 14 Bit.

The module cycle time is a constant, irrespective of how many channels are enabled. It therefore has no effect on the filter settling time, which is defined by the parameter assignment of interference frequency suppression and smoothing.

Note

It is only advisable to parameterize smoothing if you also parameterize interference frequency suppression; otherwise, the measured value resolution will be reduced to 9 bits (analog value representation is right aligned in this case).

Filter Settling Time with Strong Smoothing

Table 5-57 Interference Frequency Suppression and Filter Settling Time with Smoothing of the SM 431; AI 8 × 14 Bit (6ES7431-1KF20-0AB0)

| Interference Suppression | Smoothing | Filter settling time in ms |
|--------------------------|-----------|----------------------------|
| None | High | – |
| 50 Hz | High | 100 |
| 60 Hz | High | 83.333 |
| 400 Hz | High | 12.5 |

Step Response with Strong Smoothing

The following figure illustrates the contents of Table 5-57. It shows the filter settling time after which, in the case of a step response, the smoothed analog value is applied to almost 100%, depending on the interference frequency suppression that has been set. The figure applies to every change of signal at an analog input.

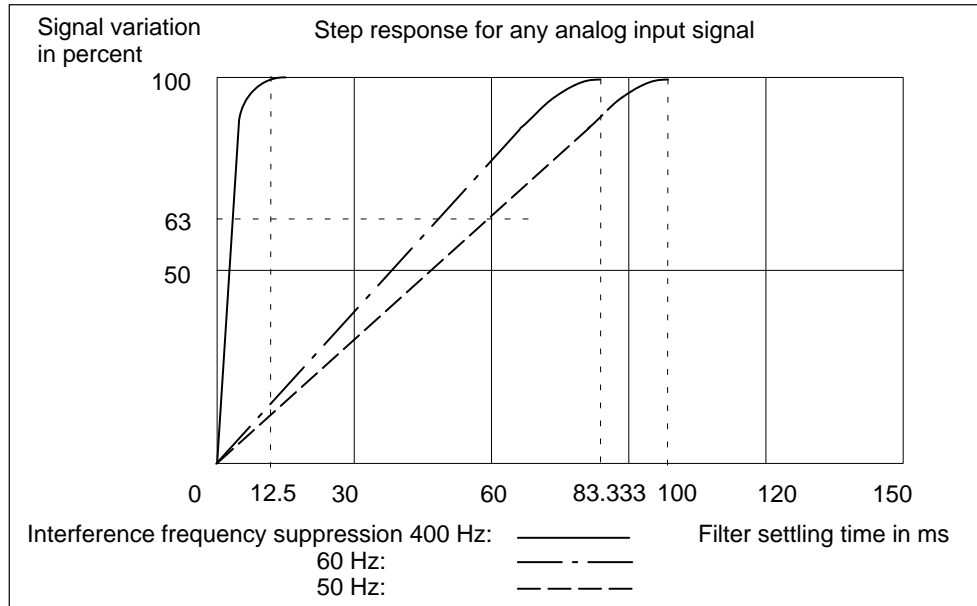

Figure 5-32 Step Response of the SM 431; AI 8 × 14 Bit (6ES7 431-1KF20-0AB0)

5.20.2 Measuring Methods and Measuring Ranges of the SM 431; AI 8 × 14 Bit

Measuring Methods

You can set the following measuring methods for the input channels:

- Voltage measurement
- Current measurement
- Resistance test

You specify the setting by means of the measuring range modules on the module and the "Measuring Type" parameter in *STEP 7*.

Circuit Variants of the Channels

Two channels are set in each case with the measuring range module. There are therefore restrictions as regards the measuring method for the adjacent channels 0/1, 2/3, 4/5 and 6/7, as shown in the following table:

Table 5-58 Selection of the Measuring Method for Channel n and Channel n+1 of the SM 431; AI 8 × 14 Bit (6ES7 431-1KF20-0AB0)

| Meas. Type Channel n+1 \ Meas. Type Channel n | Disabled | Voltage ± 1 V | Voltage 1 to 5 V | Voltage ± 10 V | Current 4-DMU | Current 2-DMU | R-4L |
|---|----------|---------------|------------------|----------------|---------------|---------------|------|
| Disabled | x | x | x | x | x | x | |
| Voltage ± 1 V | x | x | | | | | |
| Voltage 1 to 5 V | x | | x | x | | | |
| Voltage ± 10 V | x | | x | x | | | |
| Current four-wire transmitter | x | | | | x | | |
| Current two-wire transmitter | x | | | | | x | |
| Resistance four-conductor | x | | | | | | |

Example

If you select “current (two-wire transmitter)” for channel 6, you can only disable the measuring method or set “current (two-wire transmitter)” for channel 7.

Circuit for Resistance Measurement

The following conditions apply when measuring the resistance with the SM 431; AI 8 x 14 Bit:

Table 5-59 Channels for Resistance Measurement of the SM 431; AI 8 × 14 Bit (6ES7431-1KF20-0AB0)

| Measuring Type Parameter | Permissible for Channel n | Condition |
|------------------------------------|---------------------------|---|
| Resistor (four-conductor terminal) | 0, 2, 4 or 6 | You must disable the “Measuring Type” parameter for channels n+1 (1, 3, 5, 7). The reason The connections of channel n+1 are used to supply the resistance that is connected to channel n. |

Unused Channels

Unused channels can usually be left open. Put the measuring range modules in position “B”. You can improve the noise immunity of the module in a measuring environment with serious interference by connecting M– and M_{ANA}.

Measuring Ranges

You set the measuring ranges by means of the measuring range modules on the module and the “Measuring Type” parameter in *STEP 7*.

Table 5-60 Measuring Ranges of the SM 431; AI 8 x 14 Bit (6ES7431-1KF20-0AB0)

| Method Selected | Measuring Range (Type of Sensor) | Measuring Range Module Setting | Description |
|--|----------------------------------|--------------------------------|---|
| U: Voltage | ± 1 V | A | You will find the digitized analog values in Section 5.3.1 in the voltage measuring range |
| | 1 to 5 V | B | |
| | ± 10 V | | |
| 2DMU: Current (two-wire transmitter) | 4 to 20 mA | D | To supply these transmitters with current you must connect 24 V to the L+ and M front connector terminals. You will find the digitized analog values in Section 5.3.1 in the current measuring range |
| 4DMU: Current (four-wire transmitter) | 4 to 20 mA ± 20 mA | C | You will find the digitized analog values in Section 5.3.1 in the current measuring range |
| R-4L: Resistor (four-conductor terminal) | 600 Ω | A | You will find the digitized analog values in Section 5.3.1 in the resistance measuring range |

Default Settings

The module has the following default settings in *STEP 7*:

- Channels 0 to 7: “Voltage” for the measuring method ; “± 10 V” for the measuring range

You can use these measuring methods and measuring ranges without parameterizing the SM 431; AI 8 × 14 Bit in *STEP 7*.

5.21 Analog Input Module SM 431; AI 16 × 13 Bit; (6ES7431-0HH00-0AB0)

Characteristics

The analog input module SM 431; AI 13 × 16 Bit has the following features:

- 16 inputs for voltage/current measurement
- Unlimited measuring range selection
- 13-bit resolution
- Non-isolated between the analog section and bus
- The maximum permissible common mode voltage between the channels and the reference potentials of the connected sensors and central ground point is 2 VDC/VAC

Block Diagram of the SM 431; AI 16 x 13 Bit

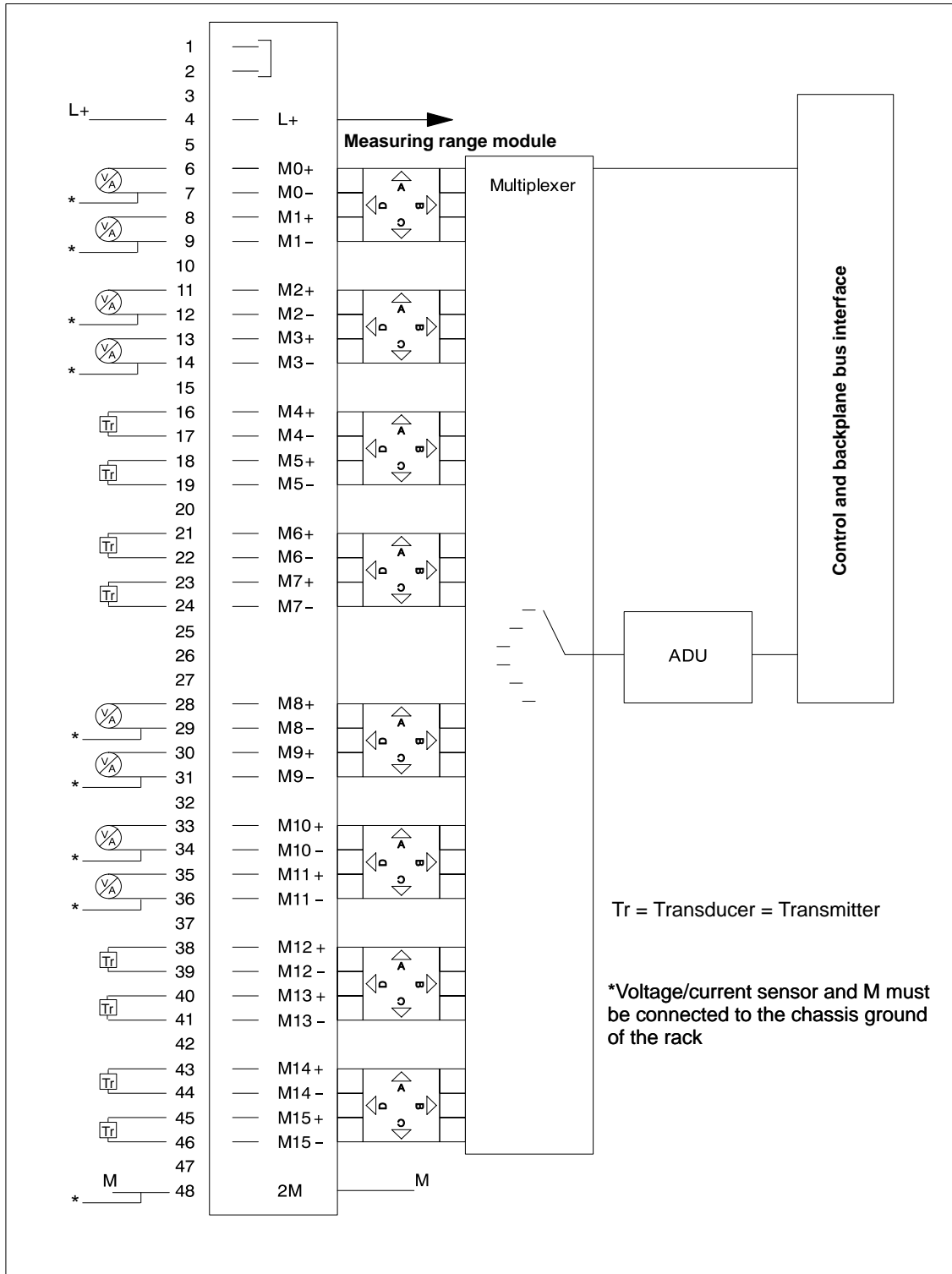

Figure 5-33 Block Diagram of the SM 431; AI 16 x 13 Bit

Terminal Assignment Diagram of the SM 431; AI 16 x 13 Bit

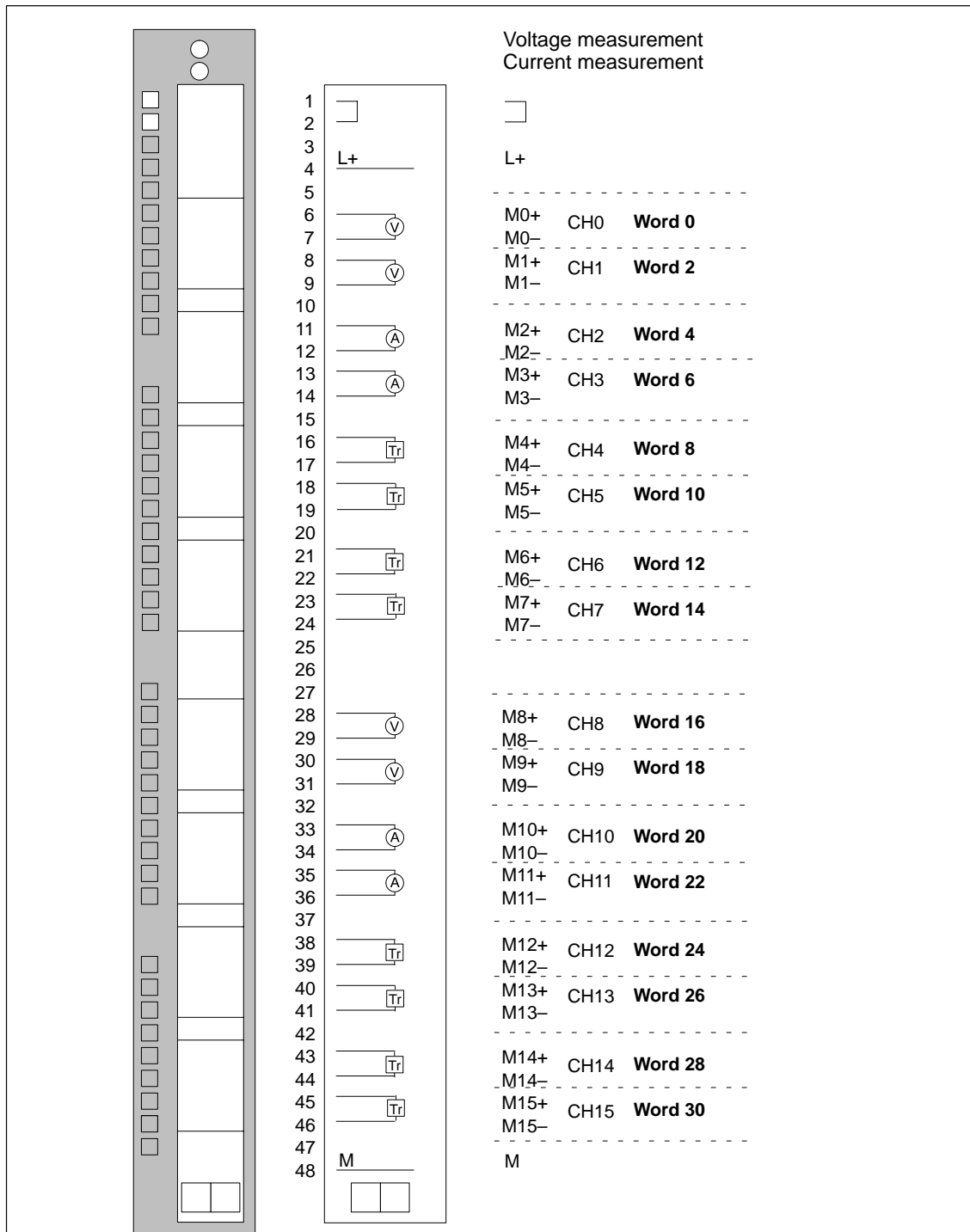

Figure 5-34 Terminal Assignment Diagram of the SM 431; AI 16 x 13 Bit

Technical Specifications of the SM 431; AI 16 x 13 Bit

| Dimensions and Weight | |
|--|--|
| Dimensions W × H × D (in millimeters) | 25 × 290 × 210 |
| Weight | Approx. 500 g |
| Data for Specific Module | |
| Number of inputs | 16 |
| • Shielded | Max. 200 m |
| Voltages, Currents, Potentials | |
| Rated load voltage L+ | 24 VDC (only required for the supply of 2-wire transmitters) |
| • Reverse polarity protection | Yes |
| Power supply of the transmitters | |
| • Supply current | Max. 50 mA |
| • Short-circuit proof | Yes |
| Constant measured current for resistance-type sensor | Typ. 1.67 mA |
| Isolation | |
| • Between channels and backplane bus | No |
| • Between the channels | No |
| • Between channels and load voltage L+ | No |
| Permitted potential difference | |
| • Between inputs and M _{ANA} (U _{CM}) | 2 VDC/2 VAC _{SS} |
| • Between the inputs (E _{CM}) | 2 VDC/2 VAC _{SS} |
| Insulation tested with | |
| • Between bus and chassis ground | 500 VDC |
| Current consumption | |
| • From the backplane bus | Max. 100 mA |
| • From load voltage L+ (with 16 connected, fully controlled two-wire transmitters) | Max. 400 mA |
| Power dissipation of the module | Typ. 2 W |
| Analog Value Generation | |
| Measuring principle | Integrative |
| Integration time/conversion time/resolution (per channel) | (Does not go into the response time) |
| • Parameters can be assigned | Yes |
| • Interference voltage suppression f1 in Hz | 60/50 |
| • Integration time in milliseconds | 50/60 |
| • Basic conversion time in ms | 55/65 |
| • Resolution including sign | 13 bits |
| Smoothing of the measured values | Not possible |
| Basic execution time of the module, in ms (all channels enabled) | 880/1040 |
| Suppression of Interference, Limits of Error | |
| Interference voltage suppression for $f = nx$ ($f1 \pm 1\%$), ($f1$ = interference frequency) $n = 1, 2, \dots$ | |
| • Common-mode interference (U _{CM} < 2 V) | > 86 dB |
| • Series-mode interference (peak value of interference < rated value of input range) | > 60 dB |
| Crosstalk between the inputs | > 50 dB |
| Operational limit (in the entire temperature range, with reference to the input range) | |
| • Voltage input | |
| – ± 1 V | ± 0.65% |
| – ± 10 V | ± 0.65% |
| – 1 V to 5 V | ± 1 % |
| • Current input | |
| – ± 20 mA | ± 0.65% |
| – 4 mA to 20 mA | ± 0.65% |
| Basic error (operational limit at 25 °C, referred to input range) | |
| • Voltage input | |
| – ± 1 V | ± 0.25% |
| – ± 10 V | ± 0.25% |
| – 1 V to 5 V | ± 0.5% |
| • Current input | |
| – ± 20 mA | ± 0.25% |
| – 4 mA to 20 mA | ± 0.25% |
| Temperature error (with reference to the input range) | ± 0.01% |
| Linearity error (with reference to the input range) | ± 0.05% |
| Repeat accuracy (in the steady state at 25 °C, referred to the input range) | ± 0.01% |
| Status, Interrupts, Diagnostics | |
| Interrupts | None |
| Diagnostic functions | None |
| Substitute value can be applied | No |

| Data for Selecting a Sensor | | Connection of the signal sensor | |
|---|---|------------------------------------|------------|
| Input range (rated values)/Input resistance | | • For measuring voltage | Possible |
| • Voltage | ± 1 V/10 MΩ ± 10 V/100 MΩ 1 V to 5 V/100 MΩ | • For measuring current | |
| • Current | ± 20 mA/50 Ω 4 mA to 20 mA/50 Ω | – As two-wire transmitter | Possible |
| Maximum input voltage for voltage input (destruction limit) | 20 V continuous; 75 V for 1 ms (cycle factor 1 : 20) | – As four-wire transmitter | Possible |
| Maximum input current for current input (destruction limit) | 40 mA | • Load of the two-wire transmitter | Max. 750 Ω |
| | | Characteristic linearization | No |

5.21.1 Commissioning the SM 431; AI 16 × 13 Bit

You set the mode of operation of the SM 431; AI 16 × 13 Bit by means of measuring range modules on the module and in *STEP 7*.

Measurement Range Modules

A measuring range module of the module matches two consecutive channels to each type of sensor. If necessary, the measuring range modules must be replugged to change the measuring method and the measuring range. The steps you have to perform to do this are described in detail in Section 5.4.

The corresponding table in Section 5.21.2 tells you which assignment you have to select for which measuring method and measuring range. In addition, the necessary settings are embossed on the module.

Parameters

You will find a description of the general procedure for assigning parameters to analog modules in Section 5.7.

An overview of the parameters that you can set and their default settings are shown in the table below.

Table 5-61 Parameters of the SM 431; AI 16 × 13 Bit

| Parameter | Value Range | Default ¹⁾ | Parameter Type | Scope |
|----------------------------|--|-----------------------|----------------|---------|
| Measurement | | | | |
| • Measuring type | Disabled U Voltage 4DMU Current (four-wire transmitter) 2DMU Current (two-wire transmitter) | U | Static | Channel |
| • Measuring range | Refer to Section 5.21.2 for the measuring ranges of the input channels that you can set. | ± 10 V | | |
| • Interference suppression | 60 Hz; 50 Hz | 50 Hz | | |

¹⁾ Only in the CC (central controller) is it possible to start up the analog modules with the default settings.

5.21.2 Measuring Methods and Measuring Ranges of the SM 431; AI 16 × 13 Bit

Measuring Methods

You can set the following measuring methods for the input channels:

- Voltage measurement
- Current measurement

You specify the setting by means of the measuring range modules on the module and the “Measuring Type” parameter in *STEP 7*.

Circuit Variants of the Channels

Two channels are set in each case with the measuring range module. There are therefore restrictions as regards the measuring method for the adjacent channels 0/1, 2/3, 4/5, 6/7, 8/9, 10/11, 12/13 and 14/15, as shown in the following table:

Table 5-62 Selection of the Measuring Method for Channel n and Channel n+1 of the SM 431; AI 16 × 13 Bit

| Meas. Type Channel n+1 \ Meas. Type Channel n | Disabled | Voltage ± 1 V | Voltage 1 to 5 V | Voltage ± 10 V | Current 4-DMU | Current 2-DMU |
|---|----------|---------------|------------------|----------------|---------------|---------------|
| Disabled | x | x | x | x | x | x |
| Voltage ± 1 V | x | x | | | | |
| Voltage 1 to 5 V | x | | x | x | | |
| Voltage ± 10 V | x | | x | x | | |
| Current four-wire transmitter | x | | | | x | |
| Current two-wire transmitter | x | | | | | x |

Example

If you select “current (two-wire transmitter)” for channel 6, you can only disable the measuring method or set “current (two-wire transmitter)” for channel 7.

Unused Channels

Unused channels can usually be left open. Put the measuring range modules in position “B”. You can improve the noise immunity of the module in a measuring environment with serious interference by connecting M– and chassis ground.

Disable the “Measuring Type” parameter for unused channels. In this way you shorten the scan time of the module.

Measuring Ranges

You set the measuring ranges by means of the measuring range modules on the module and the “Measuring Type” parameter in *STEP 7*.

Table 5-63 Measuring Ranges of the SM 431; AI 16 x 13 Bit

| Method Selected | Measuring Range (Type of Sensor) | Measuring Range Module Setting | Description |
|---------------------------------------|----------------------------------|--------------------------------|---|
| U: Voltage | ± 1 V | A | You will find the digitized analog values in Section 5.3.1 in the voltage measuring range |
| | 1 to 5 V | B | |
| | ± 10 V | | |
| 2DMU: Current (two-wire transmitter) | 4 to 20 mA | D | To supply these transmitters with current you must connect 24 V to the L+ and M front connector terminals. You will find the digitized analog values in Section 5.3.1 in the current measuring range |
| 4DMU: Current (four-wire transmitter) | 4 to 20 mA ± 20 mA | C | You will find the digitized analog values in Section 5.3.1 in the current measuring range |

Default Settings

The default settings of the module in *STEP 7* are “Voltage” for the measuring method and “± 10 V” for the measuring range. You can use this combination of measuring method and measuring range without parameterizing the SM 431; AI 16 × 13 Bit in *STEP 7*.

5.22 Analog Input Module SM 431; AI 16 × 16 Bit; (6ES7431-7QH00-0AB0)

Characteristics

The analog input module SM 431; AI 16 × 16 Bit has the following features:

- 16 inputs for voltage/current and temperature measurement
- 8 inputs for resistance measurement
- Unlimited measuring range selection
- 16-bit resolution
- Programmable diagnostics
- Programmable diagnostic interrupt
- Programmable hardware interrupt when limit has been exceeded
- Programmable end-of-scan-cycle interrupt
- Analog section isolated from CPU
- The maximum permissible common mode voltage between the channels and between the channel and the central ground point is 120 VAC

Block Diagram of the SM 431; AI 16 × 16 Bit

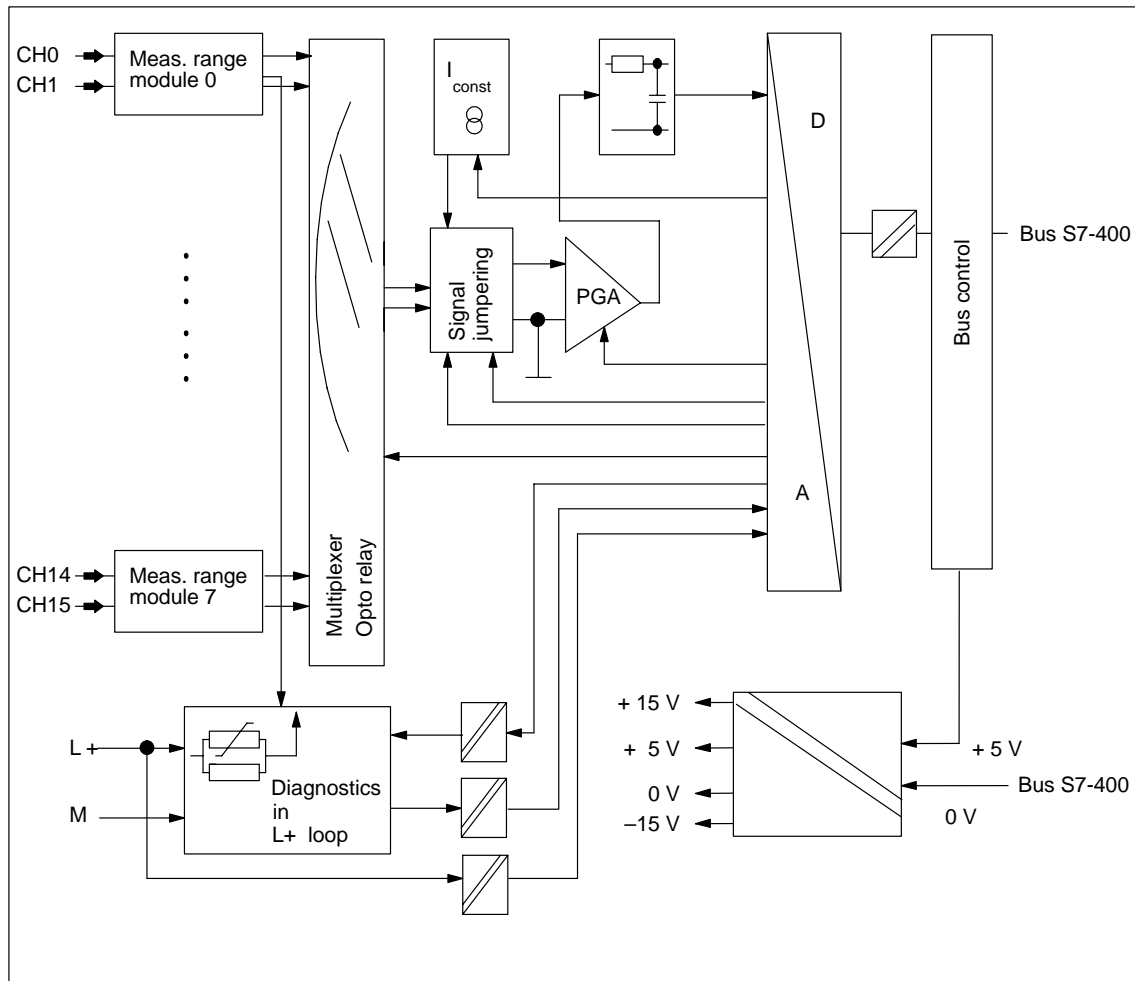

Figure 5-35 Block Diagram of the SM 431; AI 16 x 16 Bit

Terminal Assignment Diagram of the SM 431; AI 16 × 16 Bit

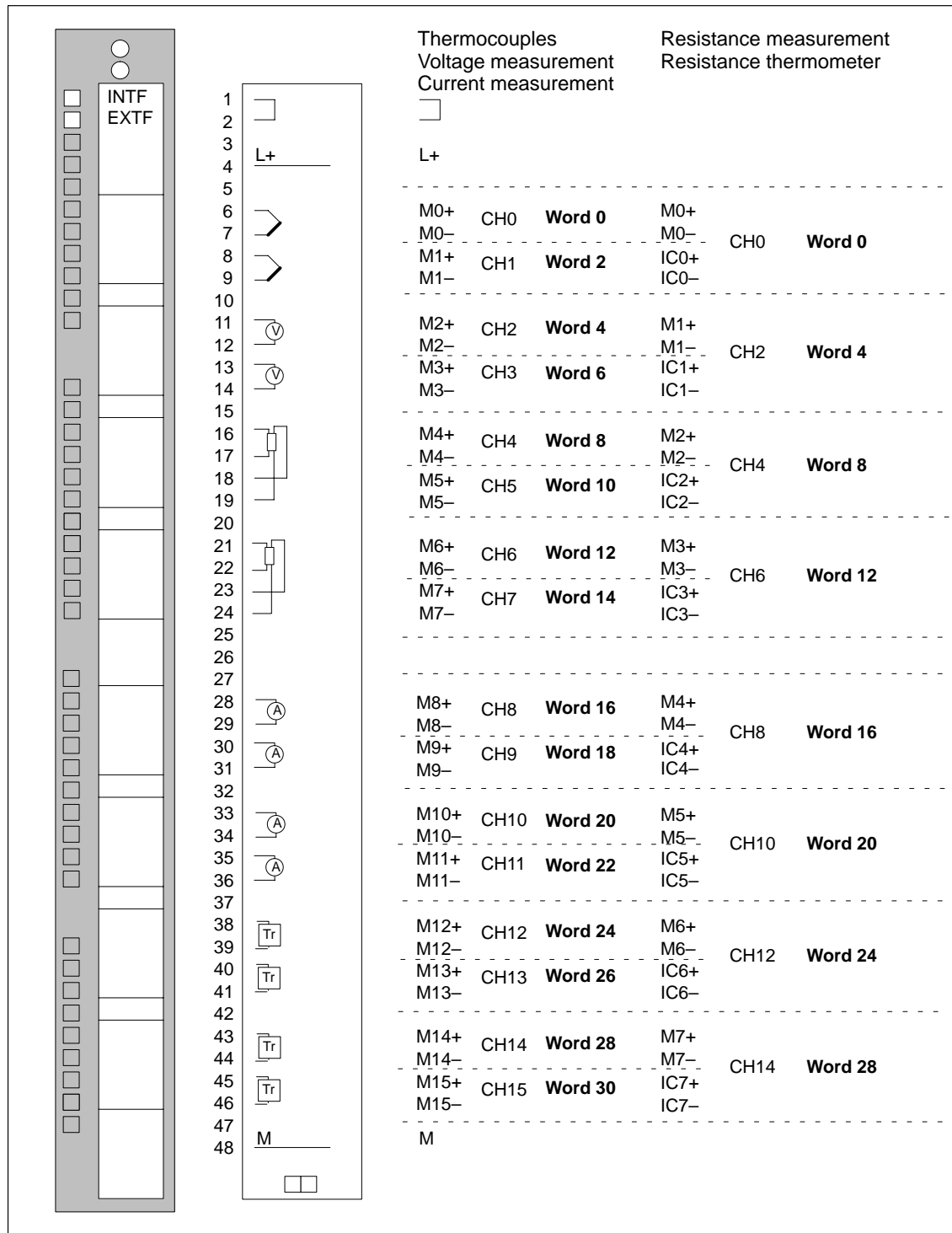

Figure 5-36 Terminal Assignment Diagram of the SM 431; AI 16 x 16 Bit

Technical Specifications of the SM 431; AI 16 × 16 Bit

| Programming package | |
|--|--|
| Associated programming package | As of STEP 7 V 2.0 |
| Dimensions and Weight | |
| Dimensions W × H × D (in millimeters) | 25 × 290 × 210 |
| Weight | Approx. 500 g |
| Data for Specific Module | |
| Number of inputs | 16 |
| • For resistance-type sensor | 8 |
| Length of cable | |
| • Shielded in the input ranges ≤ 80 mV and with thermocouples | Max. 200 m Max. 50 m |
| Voltages, Currents, Potentials | |
| Rated load voltage L+ | 24 VDC (only required for the supply of two-wire transmitters) |
| • Reverse polarity protection | Yes |
| Power supply of the transmitters | |
| • Supply current | Max. 50 mA |
| • Short-circuit proof | Yes |
| Constant measured current for resistance-type sensor | Typ. 1.67 mA |
| Isolation | |
| • Between channels and backplane bus | Yes |
| • Between the channels | No |
| • Between channels and load voltage L+ | Yes |
| Permitted potential difference | |
| • Between inputs and M _{ANA} (U _{CM}) | 120 VAC |
| • Between the inputs (E _{CM}) | 120 VAC |
| • Between M _{ANA} and M _{internal} (U _{ISO}) | 75 VDC/60 VAC |
| Insulation tested with | |
| • Between bus and L+/M | 2120 VDC |
| • Between bus and analog section | 2120 VDC |
| • Between bus and chassis ground | 500 VDC |
| • Between analog section and L+/M | 707 VDC |
| • Between analog section and chassis ground | 2120 VDC |
| • Between L+/M and chassis ground | 2120 VDC |
| Current consumption | |
| • From the backplane bus | Max. 700 mA |
| • From load voltage L+ (with 16 connected, fully controlled two-wire transmitters) | Max. 400 mA |
| Power dissipation of the module | Typ. 4.5 W |
| Analog Value Generation | |
| Measuring principle | Integrative |
| Integration time/conversion time/resolution (per channel) | (Does not go into the response time) |
| • Parameters can be assigned | Yes |
| • Interference voltage suppression f1 in Hz | 400/60/50 |
| • Integration time in ms | 2.5/16.7/20 |
| • Basic conversion time in ms | 6/20.1/23.5 |
| • Additional conversion time for measuring resistance, in ms | 12/40.2/47 |
| • Additional conversion time for open-circuit monitoring, in ms | 4.3/4.3/4.3 |
| • Additional conversion time for measuring resistance in ms | 5.5/5.5/5.5 |
| • Resolution including sign | 16/16/16 bit |
| Smoothing of the measured values | Parameters can be assigned in 4 stages |
| Basic execution time of the module, in ms (all channels enabled) | 96/322/376 |

| Suppression of Interference, Limits of Error | |
|--|--------------|
| Interference voltage suppression for $f = nx$ ($f1 \pm 1\%$), ($f1 =$ interference frequency) $n = 1, 2, \dots$ | |
| • Common-mode interference ($U_{CM} < 120 V_{SS}$) | > 100 dB |
| • Series-mode interference (peak value of interference < rated value of input range) | > 40 dB |
| Crosstalk between the inputs | > 70 dB |
| Operational limit (in the entire temperature range, with reference to the input range) | |
| • Voltage input | |
| – ± 25 mV | $\pm 0.35\%$ |
| – ± 50 mV | $\pm 0.32\%$ |
| – ± 80 mV | $\pm 0.31\%$ |
| – ± 250 mV | $\pm 0.3\%$ |
| – ± 500 mV | $\pm 0.3\%$ |
| – ± 1 V | $\pm 0.3\%$ |
| – ± 2.5 V | $\pm 0.3\%$ |
| – ± 5 V | $\pm 0.3\%$ |
| – 1 V to 5 V | $\pm 0.3\%$ |
| – ± 10 V | $\pm 0.3\%$ |
| • Current input | |
| – 0 mA to 20 mA | $\pm 0.3\%$ |
| – ± 5 mA | $\pm 0.3\%$ |
| – ± 10 mA | $\pm 0.3\%$ |
| – ± 20 mA | $\pm 0.3\%$ |
| – 4 mA to 20 mA | $\pm 0.3\%$ |
| • Resistance test | |
| – 0 to 48 Ω ; four-conductor measurement | $\pm 0.3\%$ |
| – 0 to 150 Ω , four-conductor measurement | $\pm 0.3\%$ |
| – 0 to 300 Ω , four-conductor measurement | $\pm 0.3\%$ |
| – 0 to 600 Ω ; four-conductor measurement | $\pm 0.3\%$ |
| – 0 to 5000 Ω ; four-conductor measurement (in the range of 6000 Ω) | $\pm 0.3\%$ |
| – 0 to 300 Ω ; three-conductor measurement | $\pm 0.4\%$ |
| – 0 to 600 Ω ; three-conductor measurement | $\pm 0.4\%$ |
| – 0 to 5000 Ω ; three-conductor measurement (in the range of 6000 Ω) | $\pm 0.4\%$ |
| • Thermocouples | |
| – TC type B | ± 11.5 K |
| – TC type R | ± 7.3 K |
| – TC type S | ± 8.3 K |
| – TC type T | ± 1.7 K |
| – TC type E | ± 3.2 K |
| – TC type J | ± 4.3 K |
| – TC type K | ± 6.2 K |
| – TC type U | ± 2.8 K |
| – TC type L | ± 4.2 K |
| – TC type N | ± 4.4 K |
| • Resistance thermocouples, four-conductor standard measuring range | |
| – Pt 100 | ± 3.1 K |
| – Pt 200 | ± 4.9 K |
| – Pt 500 | ± 3.9 K |
| – Pt 1000 | ± 3.1 K |
| – Ni 100 | ± 0.8 K |
| – Ni 1000 | ± 0.8 K |
| Climatic measuring range | |
| – Pt 100 | ± 0.4 K |
| – Pt 200 | ± 0.4 K |
| – Pt 500 | ± 0.4 K |
| – Pt 1000 | ± 0.4 K |
| – Ni 100 | ± 0.8 K |
| – Ni 1000 | ± 0.8 K |
| • Resistance thermocouples, three-conductor standard measuring range | |
| – Pt 100 | ± 4.2 K |
| – Pt 200 | ± 6.5 K |
| – Pt 500 | ± 5.2 K |
| – Pt 1000 | ± 4.2 K |
| – Ni 100 | ± 1.0 K |
| – Ni 1000 | ± 1.0 K |
| Climatic measuring range | |
| – Pt 100 | ± 0.5 K |
| – Pt 200 | ± 0.5 K |
| – Pt 500 | ± 0.5 K |
| – Pt 1000 | ± 0.5 K |
| – Ni 100 | ± 1.0 K |
| – Ni 1000 | ± 1.0 K |

| | | |
|---|--|---|
| <p>Basic error (operational limit at 25 °C, referred to input range)</p> <ul style="list-style-type: none"> • Voltage input <ul style="list-style-type: none"> - ± 25 mV ± 0.23% - ± 50 mV ± 0.19% - ± 80 mV ± 0.17% - ± 250 mV ± 0.15% - ± 500 mV ± 0.15% - ± 1 V ± 0.15% - ± 2.5 V ± 0.15% - ± 5 V ± 0.15% - 1 V to 5 V ± 0.15% - ± = 10 V ± 0.15% • Current input <ul style="list-style-type: none"> - 0 mA to 20 mA ± 0.15% - ± 5 mA ± 0.15% - ± 10 mA ± 0.15% - ± 20 mA ± 0.15% - 4 mA to 20 mA ± 0.15% • Resistance test <ul style="list-style-type: none"> - 0 to 48 Ω; four-conductor measurement ± 0.15% - 0 to 150 Ω; four-conductor measurement ± 0.15% - 0 to 300 Ω; four-conductor measurement ± 0.15% - 0 to 600 Ω; four-conductor measurement ± 0.15% - 0 to 5000 Ω; four-conductor measurement (in the range of 6000 Ω) ± 0.15% - 0 to 300 Ω; three-conductor measurement ± 0.3% - 0 to 600 Ω; three-conductor measurement ± 0.3% - 0 to 5000 Ω; three-conductor measurement (in the range of 6000 Ω) ± 0.3% | | <ul style="list-style-type: none"> • Thermocouples <ul style="list-style-type: none"> - TC type B ± 7.6 K - TC type R ± 4.8 K - TC type S ± 5.4 K - TC type T ± 1.1 K - TC type E ± 1.8 K - TC type J ± 2.3 K - TC type K ± 3.4 K - TC type U ± 1.7 K - TC type L ± 2.3 K - TC type N ± 2.6 K • Resistance thermocouples, four-conductor standard measuring range <ul style="list-style-type: none"> - Pt 100 ± 1.6 K - Pt 200 ± 2.5 K - Pt 500 ± 2.0 K - Pt 1000 ± 1.6 K - Ni 100 ± 0.4 K - Ni 1000 ± 0.4 K <p>Climatic measuring range</p> <ul style="list-style-type: none"> - Pt 100 ± 0.2 K - Pt 200 ± 0.2 K - Pt 500 ± 0.2 K - Pt 1000 ± 0.2 K - Ni 100 ± 0.4 K - Ni 1000 ± 0.4 K • Resistance thermocouples, three-conductor standard measuring range <ul style="list-style-type: none"> - Pt 100 ± 3.1 K - Pt 200 ± 4.9 K - Pt 500 ± 3.9 K - Pt 1000 ± 3.1 K - Ni 100 ± 0.8 K - Ni 1000 ± 0.8 K <p>Climatic measuring range</p> <ul style="list-style-type: none"> - Pt 100 ± 0.4 K - Pt 200 ± 0.4 K - Pt 500 ± 0.4 K - Pt 1000 ± 0.4 K - Ni 100 ± 0.8 K - Ni 1000 ± 0.8 K <p>Temperature error (with reference to the input range) ± 0.004% K</p> <p>Linearity error (with reference to the input range) ± 0.01% K</p> <p>Repeat accuracy (in the steady state at 25 °C, referred to the input range) ± 0.1%</p> |
|---|--|---|

| Status, Interrupts, Diagnostics | |
|---|--|
| Interrupts | |
| • Hardware interrupt | Parameters can be assigned |
| • Hardware interrupt when limit has been exceeded | Parameters can be assigned |
| • Diagnostic Interrupt | Parameters can be assigned |
| Diagnostic functions | |
| • Group error display | |
| – For internal fault | Red LED (INTF) |
| – For external fault | Red LED (EXTF) |
| • Diagnostic information readable | Yes |
| Substitute value can be applied | No |
| Data for Selecting a Sensor | |
| Input range (rated values)/Input resistance | |
| • Voltage | ± 25 mV/1 MΩ ± 50 mV/1 MΩ ± 80 mV/1 MΩ ± 250 mV/1 MΩ ± 500 mV/1 MΩ ± 1 V/1 MΩ ± 2.5 V/1 MΩ ± 5 V/1 MΩ 1 V to 5 V/1 MΩ ± 10 V/1 MΩ |
| • Current | 0 mA to 20 mA/50 Ω ± 5 mA/50 Ω ± 10 mA/50 Ω ± 20 mA/50 Ω 4 mA to 20 mA/50 Ω |
| • Resistors | 0 to 48 Ω/1 MΩ 0 to 150 Ω/1 MΩ 0 to 300 Ω/1 MΩ 0 to 600 Ω/1 MΩ 0 to 6000 Ω/1 MΩ (can be used up to 5000 Ω) |
| • Thermocouples | TC type B/1 MΩ TC type R/1 MΩ TC type S/1 MΩ TC type T/1 MΩ TC type E/1 MΩ TC type J/1 MΩ TC type K/1 MΩ TC type U/1 MΩ TC type L/1 MΩ TC type N/1 MΩ |
| • Resistance thermometer | Pt 100/1 MΩ Pt 200/1 MΩ Pt 500/1 MΩ Pt 1000/1 MΩ Ni 100/1 MΩ Ni 1000/1 MΩ |
| Maximum input voltage for voltage input (destruction limit) | Max. 18 V continuous; 75 V for 1 ms (cycle factor 1 : 20) |
| Maximum input current for current input (destruction limit) | 40 mA |
| Connection of the signal sensor | |
| • For measuring voltage | Possible |
| • For measuring current | |
| – As two-wire transmitter | Possible |
| – As four-wire transmitter | Possible |
| • For measuring resistance | |
| – With two-conductor terminal | Possible; cable resistance is also measured |
| – With three-conductor terminal | Possible |
| – With four-conductor terminal | Possible |
| • Load of the two-wire transmitter | Max. 750 Ω |
| Characteristic linearization | |
| • For thermocouples | Types B, R, S, T, E, J, K, U, L, N |
| • For resistance thermometer | Pt 100, Pt 200, Pt 500, Pt 1000, Ni 100, Ni 1000 |
| Temperature compensation | |
| • Internal temperature compensation | No |
| • External temperature compensation with compensating box | Possible |
| • External temperature compensation with Pt 100 | Possible |
| • Compensation for definable reference junction temperature | Possible |
| Unit for temperature measurement | Degrees Celsius |

5.22.1 Commissioning the SM 431; AI 16 × 16 Bit

You set the mode of operation of the SM 431; AI 16 × 16 Bit by means of measuring range modules on the module and in *STEP 7*.

Measuring Range Module

A measuring range module of the module matches two channels and one resistance channel to each type of sensor. If necessary, the measuring range modules must be replugged to change the measuring method and the measuring range. The steps you have to perform to do this are described in detail in Section 5.4.

The corresponding table in Section 5.22.2 tells you which assignment you have to select for which measuring method and measuring range. In addition, the necessary settings are embossed on the module.

Parameters

You will find a description of the general procedure for assigning parameters to analog modules in Section 5.7.

An overview of the parameters that you can set and their default settings are shown in the table below.

Table 5-64 Parameters of the SM 431; AI 16 × 16 Bit

| Parameter | Value Range | Default ²⁾ | Parameter Type | Scope |
|--|------------------|-----------------------|----------------|---------|
| Enable <ul style="list-style-type: none"> • Diagnostic interrupt¹⁾ • Hardware interrupt¹⁾ • Destination CPU for interrupt | Yes/no | No | Dynamic | Module |
| | Yes/no | No | | |
| Trigger for hardware interrupt <ul style="list-style-type: none"> • End of scan cycle reached at input • High limit • Low limit | 1 to 4 | – | Static | Module |
| | Yes/no | No | Static | Channel |
| Diagnostics <ul style="list-style-type: none"> • Wire break • Reference channel error • Underflow • Overflow • Short circuit to M | 32511 to – 32512 | – | Dynamic | Channel |
| | – 32512 to 32511 | | | |
| Diagnostics <ul style="list-style-type: none"> • Wire break • Reference channel error • Underflow • Overflow • Short circuit to M | Yes/no | No | Static | Channel |
| | Yes/no | No | | |
| | Yes/no | No | | |
| | Yes/no | No | | |
| | Yes/no | No | | |

Table 5-64 Parameters of the SM 431; AI 16 × 16 Bit, continued

| Parameter | Value Range | Default ²⁾ | Parameter Type | Scope |
|----------------------------|---|-----------------------|----------------|---------|
| Measurement | | | | |
| • Measuring type | Disabled U Voltage 4DMU Current (4-wire transmitter) 2DMU Current (two-wire transmitter) R-4L Resistor (four-conductor terminal) R-3L Resistor (three-conductor terminal) RTD-4L Thermal resistor (linear, four-conductor terminal) RTD-3L Thermal resistor (linear, three-conductor terminal) TC-L Thermocouple (linear) | U | Static | Channel |
| • Measuring range | Refer to Section 5.22.2 for the measuring ranges of the input channels that you can set. | ± 10 V | | |
| • reference Temperature | – 273.15 to 327.67 °C | 0.00 °C | | |
| • Interference suppression | 400 Hz; 60 Hz; 50 Hz | 50 Hz | | |
| • Smoothing | None Low Average High | None | Dynamic | Module |
| • Ref. junction | None RTD on Channel 0 Reference temperature value | None | | |

1) If you use the module in ER-1/ER-2, you must set this parameter to “No” because the interrupt lines are not available in ER-1/ER-2.

2) Only in the CC (central controller) is it possible to start up the analog modules with the default settings.

A Point to Note About Channels for Hardware Interrupts with the End of Scan Cycle Trigger

You can parameterize hardware interrupts for the end of scan cycle **for one** of the 16 channels because the module can only trigger these interrupts on one channel.

Smoothing of the Measured Values

You will find information that is generally applicable to the smoothing of analog values in Section 5.6.

The following figure indicates for the module the number of module cycles after which, in the case of a step response, the smoothed analog value is applied at almost 100%, depending on the smoothing setting. The figure applies to every change of signal at an analog input.

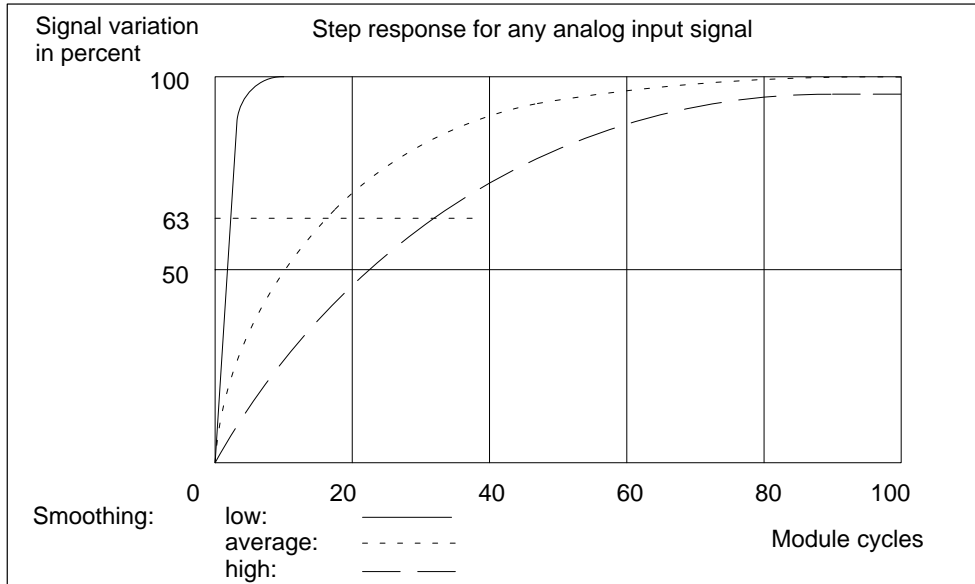

Figure 5-37 Step Response of the SM 431; AI 16 × 16 Bit (6ES7431-7QH00-0AB0)

Displaying Parameter Assignment Errors

The SM 431; AI 16 × 16 Bit has diagnostics capability. Below you will find an overview of the displays that are possible for modules with parameter assignment errors.

Table 5-65 Diagnostic Information of the SM 431; AI 16 × 16 Bit

| Incorrect Parameter Assignment | Possible Display | Explanation |
|--------------------------------|---|--|
| Of the module | <ul style="list-style-type: none"> Module malfunction Internal malfunction Wrong parameters | You can find an explanation of the diagnostic information in Tables 4-8 and 5-47 on Pages 4-10 and 5-65. |
| Affecting certain channels | <ul style="list-style-type: none"> Module malfunction Internal malfunction There is a channel error Wrong parameters Channel information available Vector channel error Channel parameter assignment error | |

5.22.2 Measuring Methods and Measuring Ranges of the SM 431; AI 16 × 16 Bit

Measuring Methods

You can set the following measuring methods for the input channels:

- Voltage measurement
- Current measurement
- Resistance test
- Temperature measurement

You specify the setting by means of the measuring range modules on the module and the “Measuring Type” parameter in *STEP 7*.

Circuit Variants for the Channels

Two channels are set in each case with the measuring range module. There are therefore restrictions as regards the measuring method for the adjacent channels 0/1, 2/3, 4/5, 6/7, 8/9, 10/11, 12/13 and 14/15, as shown in the following table:

Table 5-66 Selection of the Measuring Method for Channel n and Channel n+1 of the SM 431;
AI 16 × 16 Bit

| Meas. Type Channel n+1 \ Meas. Type Channel n | Disabled | Voltage | Current 4-DMU | Current 2-DMU | R-4L | R-3L | RTD-4L | RTD-3L | TC-L |
|---|----------|---------|---------------|---------------|------|------|--------|--------|------|
| Disabled | x | x | x | x | | | | | x |
| Voltage | x | x | | | | | | | x |
| Current four-wire transmitter | x | | x | | | | | | |
| Current two-wire transmitter | x | | | x | | | | | |
| Resistance four-conductor | x | | | | | | | | |
| Resistance three-conductor | x | | | | | | | | |
| Thermal resistor four-conductor | x | | | | | | | | |
| Thermal resistor three-conductor | x | | | | | | | | |
| Thermocouples | x | x | | | | | | | x |

Example

If you have select “current (two-wire transmitter)” for channel 6, you can only disable the measuring method or set “current (two-wire transmitter)” for channel 7.

Circuit for Resistance and Temperature Measurement

The following conditions apply when measuring the resistance and temperature with the SM 431; AI 16 x 16 Bit:

Table 5-67 Channels for Resistance and Temperature Measurement of the SM 431; AI 16 × 16 Bit

| Measuring Type Parameter | Permissible for Channel n | Condition |
|--|-----------------------------|--|
| Resistor (four-conductor terminal) | 0, 2, 4, 6, 8, 10, 12 or 14 | You must disable the “Measuring Type” parameter for channels n+1 (1, 3, 5, 7, 9, 11, 13, 15). The reason The connections of channel n+1 are used to supply the resistance that is connected to channel n. |
| Resistor three-conductor terminal | 0, 2, 4, 6, 8, 10, 12 or 14 | |
| Thermal resistor (linear, four-conductor terminal) | 0, 2, 4, 6, 8, 10, 12 or 14 | |
| Thermal resistor (linear, four-conductor terminal) | 0, 2, 4, 6, 8, 10, 12 or 14 | |
| Thermocouple (linear) | 0 to 15 | You can select the reference junction. It is only advisable to specify a reference junction with thermocouples. |

Circuit for Reference Junction Compensation for Thermocouples

If you select “RTD on Channel 0” as a reference junction for reference junction compensation for thermocouples, the following applies:

Table 5-68 Reference Junction Compensation via RTD on Channel 0 of the SM 431; AI 16 × 16 Bit

| Reference Junction Parameter | Permissible for Channel n | Condition |
|------------------------------|---------------------------|--|
| RTD on Channel 0 | 2 to 15 | You must connect and parameterize on channel 0 a resistance thermometer with linearization, a 3- or 4- conductor terminal in climatic range . This means that channels 0 and 1 are assigned. The reason If channel 0 is to be used as the reference junction, a resistance-type sensor must be connected there to establish the absolute temperatures in the climatic range. |

Unused Channels

Unused channels can usually be left open. Put the measuring range modules in position “A”. You can improve the noise immunity of the module in a measuring environment with serious interference by short-circuiting the channels.

Disable the “Measuring Type” parameter for unused channels. In this way you shorten the scan time of the module.

Measuring Ranges

You set the measuring ranges by means of the measuring range modules on the module and the “Measuring Type” parameter in *STEP 7*.

Table 5-69 Measuring Ranges of the SM 431; AI 16 x 16 Bit

| Method Selected | Measuring Range (Type of Sensor) | Measuring Range Module Setting | Description |
|---------------------------------------|--|--------------------------------|--|
| U: Voltage | ± 25 mV ± 50 mV ± 80 mV ± 250 mV ± 500 mV ± 1 V ± 2.5 V ± 5 V 1 to 5 V ± 10 V | A | You will find the digitized analog values in Section 5.3.1 in the voltage measuring range |
| 2DMU: Current (two-wire transmitter) | 4 to 20 mA | D | To supply these transmitters with current you must connect 24 V to the L+ and M front connector terminals. You will find the digitized analog values in Section 5.3.1 in the current measuring range |
| 4DMU: Current (four-wire transmitter) | ± 5 mA ± 10 mA 0 to 20 mA 4 to 20 mA ± 20 mA | C | You will find the digitized analog values in Section 5.3.1 in the current measuring range |

Table 5-69 Measuring Ranges of the SM 431; AI 16 x 16 Bit, continued

| Method Selected | Measuring Range (Type of Sensor) | Measuring Range Module Setting | Description |
|---|--|--------------------------------|--|
| R-3L: Resistor (three-conductor terminal) | 300 Ω 600 Ω 6000 Ω (max. 5000 Ω) | A | You will find the digitized analog values in Section 5.3.1 in the resistance measuring range |
| R-4L: Resistor (four-conductor terminal) | 48Ω 150 Ω 300 Ω 600 Ω 6000 Ω (max. 5000 Ω) | | |
| TC-L: Thermocouple (linear) (temperature measurement) | Type B Type N Type E Type R Type S Type J Type L Type T Type K Type U | A | You will find the digitized analog values in Section 5.3.1 in the temperature range |
| RTD-3L: thermal resistor linear, three-conductor terminal (temperature measurement) | Pt 100 climatic Pt 200 climatic Pt 500 climatic Pt 1000 climatic Ni 100 climatic Ni 1000 climatic | A | You will find the digitized analog values in Section 5.3.1 in the temperature range |
| RTD-4L: thermal resistor linear, four-conductor terminal (temperature measurement) | Pt 100 standard Pt 200 standard Pt 500 standard Pt 1000 standard Ni 100 standard Ni 1000 standard | | |

Default Settings

The default settings of the module in *STEP 7* are “Voltage” for the measuring method and “± 10 V” for the measuring range. You can use this combination of measuring method and measuring range without parameterizing the SM 431; AI 16 × 16 Bit in *STEP 7*.

Wire Break Check

The wire break check is intended primarily for temperature measurements (TC, RTD) or resistance measurements. Always parameterize the wire break check in these cases as this ensures that in the event of a wire break the measured value provided by the module accepts the data for overrun 7FFFH.

Special Characteristics of the Wire Break Check for the Voltage Measurement Methods

In some transmitters, incorrect measured values may occur due to the fact that the wire break check is enabled. If so, disable the wire break check.

The reason Some transmitters try to correct the test current and in doing so corrupt the setpoint value they provide.

Points to Note About the Wire Break Check when Current Sensors Are Connected

A wire break check of current sensors is not possible for the SM 431; AI 16 × 16 Bit except in life-zero areas. You can therefore only parameterize the wire break check for the “Current (four-wire transmitter)” measuring method and the “4 to 20 mA” measuring range.

Checking for Reference Channel Errors when Connecting Thermocouples

If you have connected a thermocouple, you can then enable the “Reference channel error” diagnosis if you have parameterized an “RTD on Channel 0” or “Reference Temperature Value” reference junction.

Points to Note About Checking for “Underflow” with some Measuring Methods and Measuring Ranges

There is now underflow in life-zero areas. A value that is too low or is negative is interpreted as a wire break. You can therefore **not** parameterize the underflow check for the SM 431; AI 16 × 16 Bit for the following measuring methods and ranges:

Table 5-70 Points to Note when Checking for “Underflow”

| Measuring Method | Measuring Range |
|---------------------------------|-----------------|
| Voltage | 1 to 5 V |
| Current (four-wire transmitter) | 4 to 20 mA |
| Current (two-wire transmitter) | 4 to 20 mA |

Points to Note About the “Short Circuit to M” Diagnosis

You can only parameterize the check for “Short Circuit to M” for the SM 431; AI 16 × 16 Bit for the “Current (2-wire transmitter)” measuring method.

5.23 Analog Input Module SM 431; AI 8 × RTD × 16 Bit; (6ES7 431-7KF10-0AB0)

Characteristics

The analog input module SM 431; AI 8 × RTD × 16 Bit has the following features:

- 8 differential inputs for the resistance thermometer
- Resistance thermometer can be parameterized
- Linearization of the resistance thermometer characteristic curves
- 16-bit resolution
- Update rate of 25 ms for 8 channels
- Programmable diagnostics
- Programmable diagnostic interrupt
- Programmable hardware interrupt when limit has been exceeded
- Analog section isolated from CPU
- The maximum permissible common mode voltage between the channel and the central ground point is 120 VAC

Calibration Software

The analog input module AI 8 x RTD x 16 Bit; (6ES7431-7KF10-0AB0) is delivered with the software "S7-400 RTD User Calibration" on two diskettes. After installing the software, you can define user-specific calibration values for each channel and and each module input range. You will find further information under ID 12436891 at the Customer Support FAQ site.

Block Diagram of the SM 431; AI 8 × RTD × 16 Bit

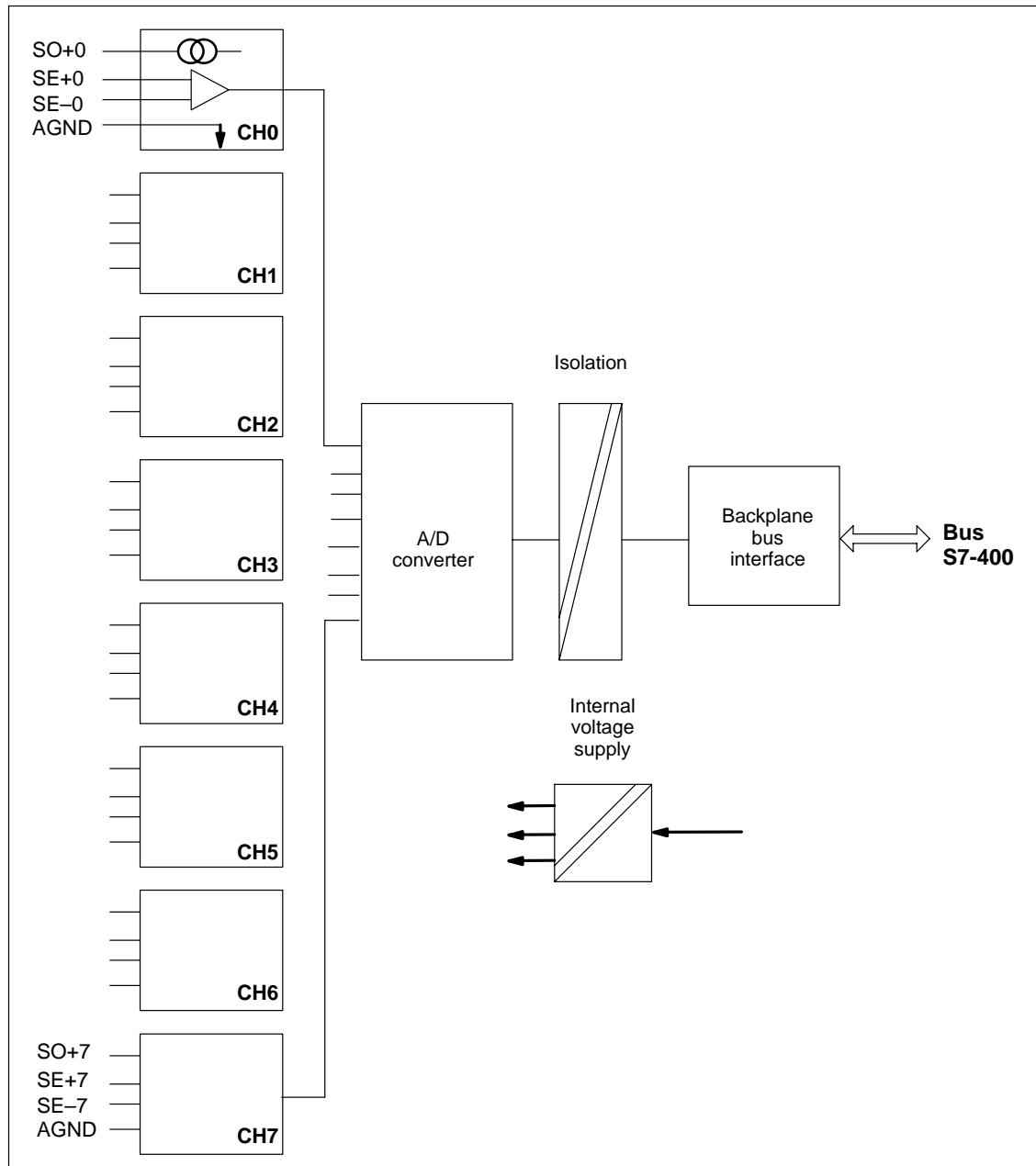

Figure 5-38 Block Diagram of the SM 431; AI 8 x RTD x 16 Bit

Note

An external protective network is required in the signal leads in accordance with IEC 61000-4-5 (150 V/14 mm MOV across each + and – input to chassis ground)

Terminal Assignment Diagram of the SM 431; AI 8 × RTD × 16 Bit

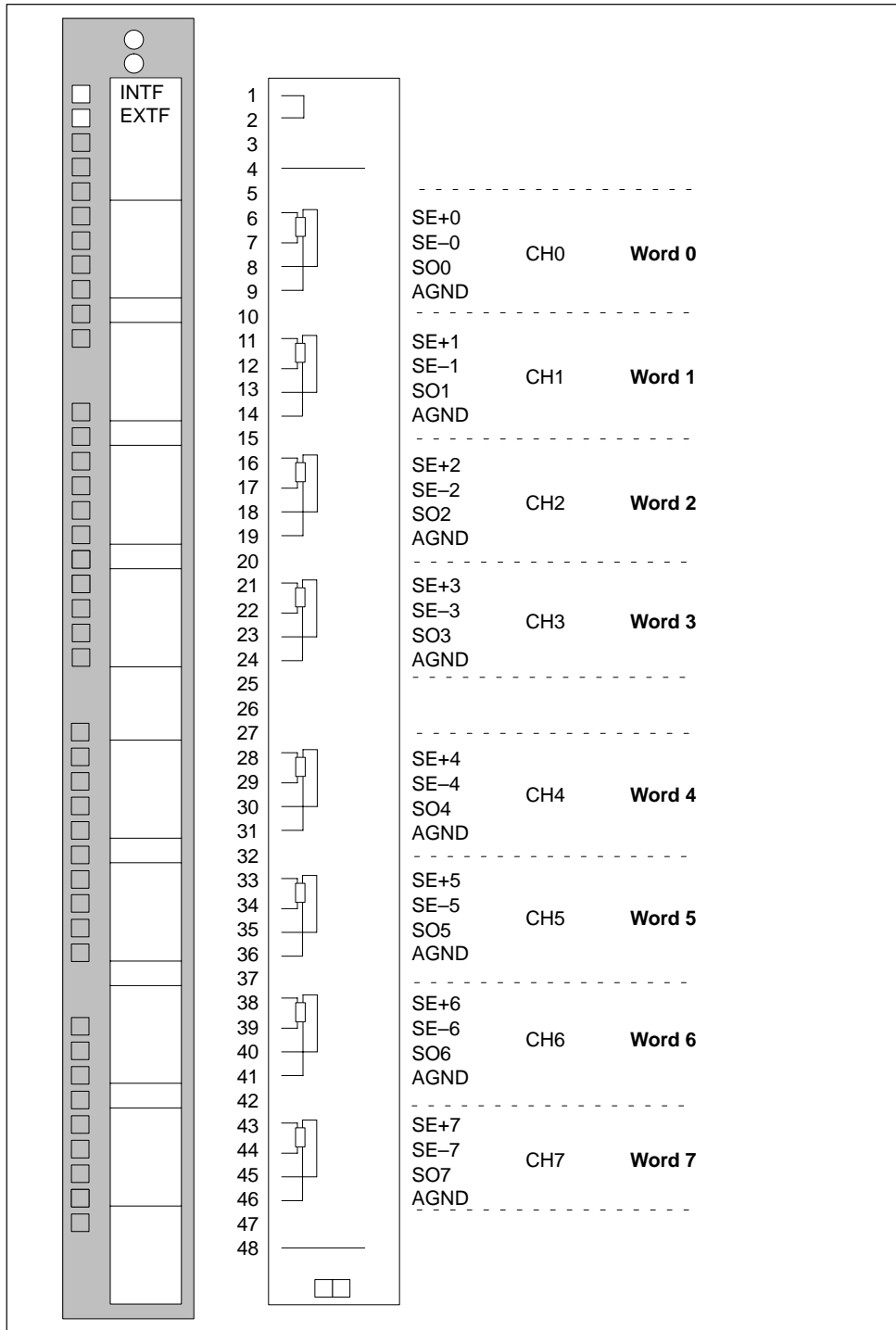

Figure 5-39 Terminal Assignment Diagram of the SM 431; AI 8 x RTD x 16 Bit

Technical Specifications of the SM 431; AI 8 × RTD × 16 Bit

| Dimensions and Weight | |
|--|--|
| Dimensions W × H × D (in millimeters) | 25 × 290 × 210 |
| Weight | Approx. 650 g |
| Data for Specific Module | |
| Number of inputs | 8 |
| • For resistance-type sensor | 4 |
| Length of cable | |
| • Shielded | Max. 200 m |
| Voltages, Currents, Potentials | |
| Constant current for resistance-type sensor | Max. 1 mA |
| Isolation | |
| • Between channels and backplane bus | Yes |
| Permitted potential difference | |
| • Between M_{ANA} and $M_{internal}$ (U_{ISO}) | 120 VAC |
| Insulation tested with | 1500 VAC |
| Current consumption | |
| • From the backplane bus | Max. 650 mA |
| Power dissipation of the module | Typ. 3.3 W |
| Analog Value Generation | |
| Measuring principle | Integrative |
| Integration/conversion time/resolution (per channel) | (Does not go into the response time) |
| • Parameterizable | Yes |
| • Basic conversion time in ms | 22/25 |
| • Additional conversion time for measuring resistance, in ms | Max. 200 |
| • Resolution including sign | 16/16 bit |
| • Noise suppression for interference frequency f_1 in Hz | 60/50 |
| Smoothing of the measured values | Parameters can be assigned in 4 stages |
| Basic response time of module (all channels enabled) | 22/25 ms |
| Suppression of interference, Limits of Error | |
| Noise suppression for $f = n \times (f_1 \pm 1\%)$, ($f_1 =$ interference frequency) $n = 1, 2$, etc. | |
| • Common-mode interference ($U_{CM} < 120V$) | > 100 dB |
| • Series-mode interference (peak value of interference < rated value of the input range) | > 50 dB |
| Crosstalk between the inputs | > 70 dB |
| Operational limit (over entire temperature range, referred to 0 to 60 °C input range) | |
| • RTD input | ± 1.0 °C |
| Basic error (operational limit at 25 °C, referred to input range) | |
| • RTD input | ± 0.5 °C |
| Temperature error (with reference to the input range) | $\pm 0.007\%/K$ |
| Linearity error (with reference to the input range) | ± 0.2 °C |
| Repeat accuracy (in the steady state at 25 °C, referred to the input range) | ± 0.2 °C |
| Status, Interrupts, Diagnostics | |
| Interrupts | |
| • Hardware interrupt when limit has been exceeded | Parameters can be assigned |
| • Diagnostic Interrupt | Parameters can be assigned |
| Diagnostic functions | Parameters can be assigned |
| • Group error display | |
| – For internal fault | Red LED (INTF) |
| – For external fault | Red LED (EXTF) |
| • Diagnostic information can be displayed | Possible |
| Data for Selecting a Sensor | |
| Input range (rated values) input resistance | |
| • Resistance thermometer | Pt 100, Pt 200, Pt 500, Pt 1000, Ni 100, Ni 1000 |
| • Maximum input voltage for voltage input (destruction limit) | 35 V continuous; 75 V for max. 1 s (duty factor 1:20) |
| Connection of the sensor | |
| • For measuring resistance | |
| With three-conductor terminal | Possible |
| With four-conductor terminal | Possible |
| Characteristic linearization | |
| • For resistance thermometer | Pt 100, 0,00385 to DIN IEC 751 Ni 100, 0,00618 to DIN 43760 |
| Unit for temperature measurement | Degrees Celsius; degrees Fahrenheit |

5.23.1 Commissioning the SM 431; AI 8 × RTD × 16 Bit

You set the mode of operation of the SM 431; AI 8 × RTD × 16 Bit in *STEP 7*.

Parameters

You will find a description of the general procedure for assigning parameters to analog modules in Section 5.7.

An overview of the parameters that you can set and their default settings are shown in the table below.

Table 5-71 Parameters of the SM 431; AI 8 × RTD × 16 Bit

| Parameter | Value Range | Default ²⁾ | Parameter Type | Scope |
|---|---|-----------------------|----------------|---------|
| Enable | | | | |
| • Diagnostic interrupt ¹⁾ | Yes/no | No | Dynamic | Module |
| • Hardware interrupt ¹⁾ | Yes/no | No | | |
| • Destination CPU for interrupt | 1 to 4 | – | Static | Module |
| Trigger for hardware interrupt ³⁾ | | | | |
| • High limit | 32767 to – 32768 | – | Dynamic | Channel |
| • Low limit | – 32768 to 32767 | | | |
| Diagnostics | | | | |
| • Wire break | Yes/no | No | | |
| • Underflow | Yes/no | No | | |
| • Overflow | Yes/no | No | | |
| Measurement | | | | |
| • Measuring type | Disabled RTD-4L Thermal resistor (linear, four-conductor terminal) RTD-3L Thermal resistor (linear, three-conductor terminal) | RTD-3L | Static | Channel |
| • Measuring range | Refer to Section 5.23.2 for the measuring ranges of the input channels that you can set. | Pt 100 standard | | |
| • Temperature unit | Degrees Celsius; degrees Fahrenheit | Degrees Celsius | Static | Module |
| • Temperature coefficient for temperature measurement with thermal resistor (RTD) | For platinum (Pt) 0.00385 Ω/Ω/ °C 0.003916 Ω/Ω/ °C 0.003902 Ω/Ω/ °C 0.003920 Ω/Ω/ °C For nickel (Ni) 0.00618 Ω/Ω/ °C 0.00672 Ω/Ω/ °C | 0.00385 | Static | Channel |

Table 5-71 Parameters of the SM 431; AI 8 × RTD × 16 Bit, continued

| Parameter | Value Range | Default ²⁾ | Parameter Type | Scope |
|---|--|-----------------------|----------------|---------|
| <ul style="list-style-type: none"> Interference suppression Smoothing | 60 Hz; 50 Hz; none None Low Average High | 60 Hz None | Static | Channel |

- 1) If you use the module in ER-1/ER-2, you must set this parameter to “No” because the interrupt lines are not available in ER-1/ER-2.
- 2) Only in the CC (central controller) is it possible to start up the analog modules with the default settings.
- 3) The limit values must be within the temperature range of the connected sensor.

Smoothing of the Measured Values

You will find information that is generally applicable to the smoothing of analog values in Section 5.6.

The following figure shows for the module the number of module cycles, in the case of a step response, after which the smoothed analog value is applied to almost 100%, depending on the smoothing setting. The figure applies to every change of signal at an analog input.

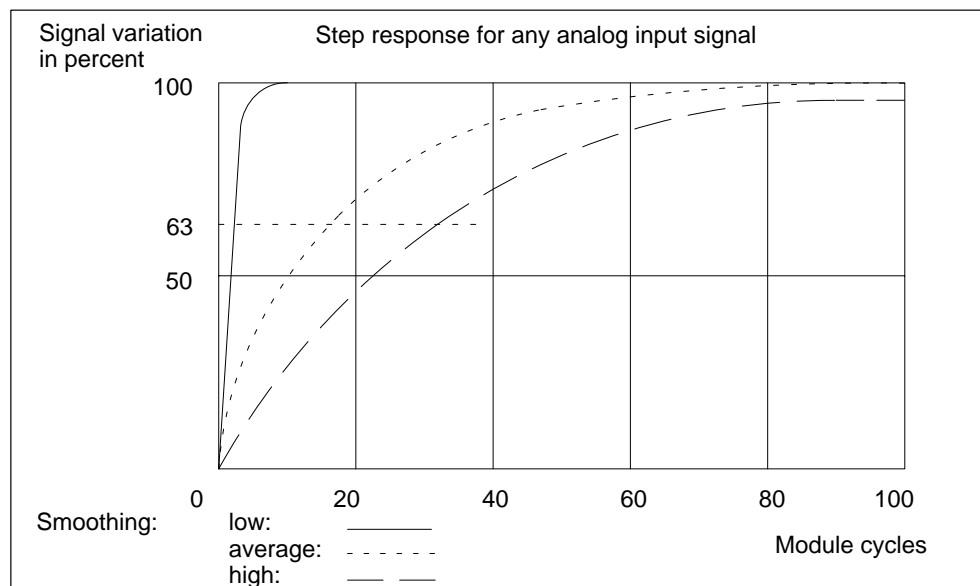

Figure 5-40 Step Response of the SM 431; AI 8 × RTD × 16 Bit

Displaying Parameter Assignment Errors

The SM 431; AI 8 × RTD × 16 Bit is capable of diagnostics. Below you will find an overview of the displays that are possible for modules with parameter assignment errors.

Table 5-72 Diagnostic Information of the SM 431; AI 8 × RTD × 16 Bit

| Incorrect Parameter Assignment | Possible Display | Explanation |
|--------------------------------|--|--|
| Of the module | <ul style="list-style-type: none"> • Module malfunction • Internal malfunction • Wrong parameters • Module not parameterized. | You can find an explanation of the diagnostic information in Tables 4-8 and 5-47 on Pages 4-10 and 5-65. |
| Affecting certain channels | <ul style="list-style-type: none"> • Module malfunction • Internal malfunction • There is a channel error • Wrong parameters • Channel information available • Vector channel error • Channel parameter assignment error • User calibration doesn't correspond to the parameter assignment | |

5.23.2 Measuring Methods and Measuring Ranges of the SM 431; AI 8 × RTD × 16 Bit

Measuring Methods

As the measuring method for the input channels, you can set the temperature measurement.

Unused Channels

Disable the “Measuring Type” parameter for unused channels. In this way you shorten the scan time of the module.

Measuring Ranges

You set the measuring ranges with the “Measuring Type” parameter in *STEP 7*.

Table 5-73 Measuring Ranges of the SM 431; AI 8 x RTD x 16 Bit

| Method Selected | Measuring Range | Description |
|--|---|---|
| RTD-3L: Thermal resistor (linear, three-conductor terminal) (temperature measurement) | Pt 100 standard Pt 200 standard Pt 500 standard Pt 1000 standard | You will find the digitized analog values in Section 5.3.1 in the temperature range |
| RTD-4L: Thermal resistor (linear, four-conductor terminal) (temperature measurement) | Ni 100 standard Ni 1000 standard | |

Default Settings

The default settings of the module in *STEP 7* are “Thermal resistor (linear, 3-conductor terminal)” for the measuring method and “Pt 100 standard” for the measuring range. You can use this measuring method with this measuring range without parameterizing the SM 431; AI 8 × RTD × 16 Bit with *STEP 7*.

5.24 Analog Input Module SM 431; AI 8 × 16 Bit; (6ES7431-7KF00-0AB0)

Characteristics

The analog input module SM 431; AI 8 × 16 Bit has the following features:

- 8 isolated differential inputs for voltage/current/temperature measurement
- Unlimited measuring range selection
- Linearization of the thermocouple characteristic curves
- 16-bit resolution
- Programmable diagnostics
- Programmable diagnostic interrupt
- Programmable hardware interrupt when limit has been exceeded
- Analog section isolated from CPU
- The maximum permissible common mode voltage between the channels and between the channel and the central ground point is 120 VAC
- Internal measured resistance
- Field connection (6ES7431-7K00-6AA0) with internal reference temperature (included with the product)

Calibration Software

The analog input module SM 431; AI x 16 Bit; (6ES7431-7KF00-0AB0) is delivered with the software “S7-400 Thermocouple User Calibration” on two diskettes. After installing the software, you can define user-specific calibration values for each channel and each module input range. You will find further information under ID 12436891 at the Customer Support FAQ site.

Block Diagram of the SM 431; AI 8 × 16 Bit

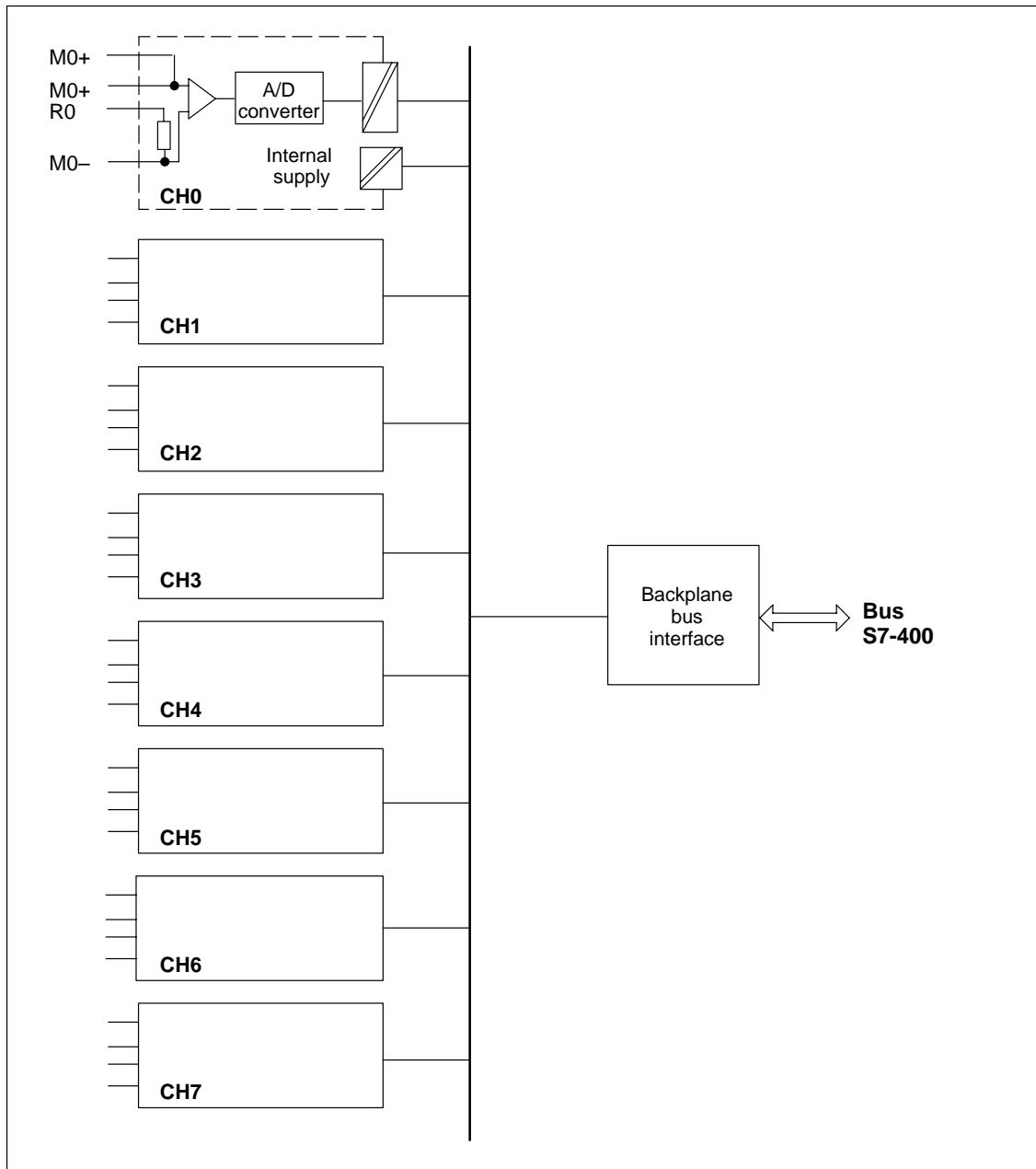

Figure 5-41 Block Diagram of the SM 431; AI 8 x 16 Bit

Note

An external protective network is required in the signal leads in accordance with IEC 61000-4-5 (150 V/14 mm MOV across each + and – input to chassis ground)

Terminal Assignment Diagram of the SM 431; AI 8 × 16 Bit

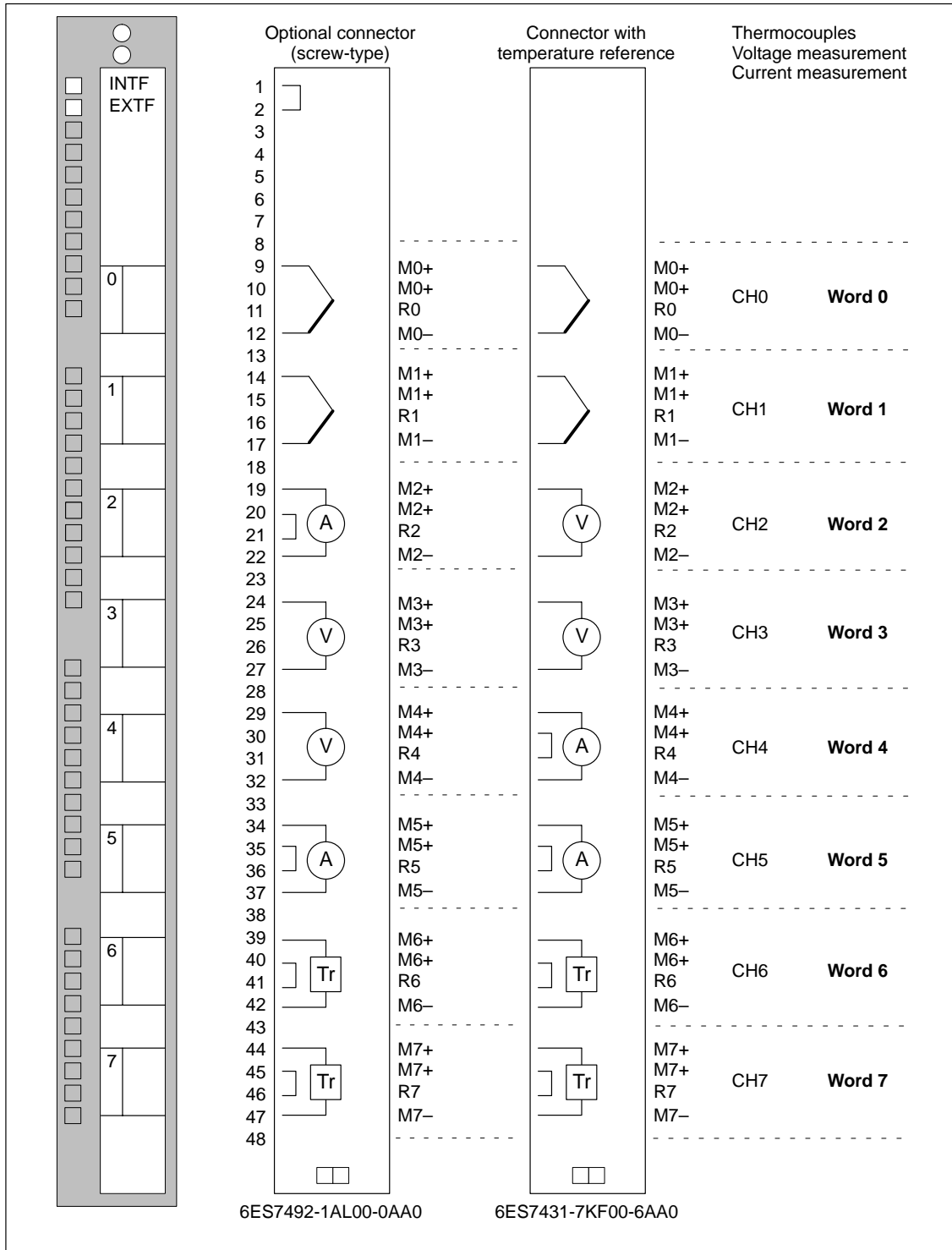

Figure 5-42 Terminal Assignment Diagram SM 431; AI 8 x 16 Bit

Technical Specifications of the SM 431; AI 8 × 16 Bit

| Dimensions and Weight | | Analog Value Generation | | | | |
|---|----------------|--|--|------|----|-----|
| Dimensions W × H × D (in millimeters) | 25 × 290 × 210 | Measuring principle | Integrative | | | |
| Weight | Approx. 650 g | Integration time/conversion time/resolution (per channel) | (Does not go into the response time) | | | |
| Data for Specific Module | | • Parameters can be assigned | Yes | | | |
| Number of inputs | 8 | • Integration time in milliseconds | 2.5 | 16.7 | 20 | 100 |
| Length of cable | | • Basic conversion time including integration time in milliseconds | 10 | 16.7 | 20 | 100 |
| • Shielded | 200 m | • Resolution in bits (incl. overrange) | 16 bits | | | |
| Voltages, Currents, Potentials | | • Noise suppression for frequency f1 in Hz | 400 | 60 | 50 | 10 |
| Isolation | | • Basic execution time of the module, in ms (all channels enabled) | 10 | 16.7 | 20 | 100 |
| • Between channels and backplane bus | Yes | Smoothing of the measured values | Parameters can be assigned in 4 stages | | | |
| • Between the channels | Yes | Suppression of Interference, Limits of Error | | | | |
| Permitted potential difference | | Interference voltage suppression for $f = n \times (f1 \pm 1\%)$, (f1 = interference frequency) n= 1.2 ... | | | | |
| • Between the inputs (U_{CM}) | 120 VAC | • Common-mode interference ($U_{CM} < 2.5$ V) | > 130 dB | | | |
| • Between M_{ANA} and $M_{internal}$ (U_{ISO}) | 120 VAC | • Series-mode noise (peak value of noise < nominal value of input range) | > 80 dB | | | |
| Insulation tested with | 1500 VAC | Crosstalk between the inputs | > 130 dB | | | |
| Current consumption | | | | | | |
| • From the backplane bus | Max. 1200 mA | | | | | |
| Power dissipation of the module | Typ. 4.6 W | | | | | |

| | | | | |
|--|------------|---|---|----------------|
| Operational limit (in the entire temperature range, with reference to the input range) | | Status, Interrupts, Diagnostics | | |
| • Voltage input | ± 0.3 % | Interrupts | | |
| • Current input | ± 0.5 % | • Hardware interrupt | Parameters can be assigned | |
| • Thermocouple | Type B | ± 3.5 °C | • Diagnostic Interrupt | Programmable |
| | Type N | ± 2.7 °C | Diagnostic functions | Programmable |
| | Type E | ± 1.8 °C | • Group error display | Programmable |
| | Type R | ± 3.3 °C | – For internal fault | Red LED (INTF) |
| | Type S | ± 3.2 °C | – For external fault | Red LED (EXTF) |
| | Type J | ± 2.4 °C | • Diagnostic information can be displayed | Yes |
| | Type L | ± 1.7 °C | | |
| | Type T | ± 0.8 °C | | |
| | Type K | ± 2.5 °C | | |
| | Type U | ± 1.2 °C | | |
| Basic error (operational limit at 25 °C, referred to input range) | | Data for Selecting a Sensor | | |
| • Voltage input | ± 0.05 % | Input range (rated values)/Input resistance | | |
| • Current input | ± 0.15 % | • Voltage | ± 25 mV >2 MΩ | |
| • Thermocouple | Type B | ± 0.9 °C | ± 50 mV >2 MΩ | |
| | Type N | ± 0.7 °C | ± 80 mV >2 MΩ | |
| | Type E | ± 0.5 °C | ± 100 mV >2 MΩ | |
| | Type R | ± 0.9 °C | ± 250 mV >2 MΩ | |
| | Type S | ± 0.8 °C | ± 500 mV >2 MΩ | |
| | Type J | ± 0.6 °C | ± 1 V >2 MΩ | |
| | Type L | ± 0.4 °C | ± 2.5 V >2 MΩ | |
| | Type T | ± 0.2 °C | ± 5 V >2 MΩ | |
| | Type K | ± 0.6 °C | ± 10 V >2 MΩ | |
| | Type U | ± 0.3 °C | • Current | ± 25 mA /50 Ω |
| Temperature error (with reference to the input range) | ± 0.015%/K | • Thermocouple | Types B, N, E, R, S, J, L, T, K, U >2 MΩ | |
| Linearity error (with reference to the input range) | ± 0.15% | Maximum input voltage for voltage input (destruction limit) | 35 V continuous; 75 V for max. 1 s (duty factor 1:20) | |
| Repeatability (in steady state at 25 °C, with reference to the input range) | ± 0.15% | Maximum input current for current input (destruction limit) | 32 mA | |
| | | Connection of the sensor | | |
| | | • For measuring voltage | Possible | |
| | | • For measuring current | | |
| | | As four-wire transmitter | Possible | |
| | | Characteristic linearization | | |
| | | • For thermocouples | Types B, N, E, R, S, J, L, T, K, U | |
| | | Temperature compensation | Yes, programmable | |
| | | • Internal temperature compensation | Possible | |
| | | Unit for temperature measurement | Degrees Celsius; degrees Fahrenheit | |

5.24.1 Commissioning the SM 431; AI 8 × 16 Bit

You set the mode of operation of the SM 431; AI 8 × 16 Bit in *STEP 7*.

Parameter

You will find a description of the general procedure for assigning parameters to analog modules in Section 5.7.

An overview of the parameters that you can set and their default settings are shown in the table below.

Table 5-74 Parameters of the SM 431; AI 8 × 16 Bit

| Parameter | Value Range | Default ²⁾ | Parameter Type | Scope |
|--|--|-----------------------|----------------|---------|
| Enable | | | | |
| • Diagnostic interrupt ¹⁾ | Yes/no | No | Dynamic | Module |
| • Hardware interrupt ¹⁾ | Yes/no | No | | |
| • Destination CPU for interrupt | 1 to 4 | – | Static | Module |
| Trigger for hardware interrupt ³⁾ | | | | |
| • High limit | 32767 to – 32768 | – | Dynamic | Channel |
| • Low limit | – 32768 to 32767 | – | | |
| Diagnostics | | | | |
| • Wire break | Yes/no | No | Static | Channel |
| • Reference channel error | Yes/no | No | | |
| • Underflow | Yes/no | No | | |
| • Overflow | Yes/no | No | | |
| Measurement | | | | |
| • Measuring method | Disabled U Voltage 4DMU Current (four-wire transmitter) TC-L Thermocouple (linear) | TC-L | Static | Channel |
| • Measuring range | Refer to Section 5.24.2 for the measuring ranges of the input channels that you can set. | Type J | | |
| • Reference temperature | – 273.15 to 327.67 °C –327.68 to 327.67 °F | 100 °C | Dynamic | Module |
| • Temperature unit ⁴⁾ | Degrees Celsius; degrees Fahrenheit | Degrees Celsius | | |
| • Interference suppression | 400 Hz; 60 Hz; 50 Hz; 10 Hz | 60 Hz | Static | Module |

Table 5-74 Parameters of the SM 431; AI 8 × 16 Bit, continued

| Parameter | Value Range | Default ²⁾ | Parameter Type | Scope |
|---|---|-----------------------|----------------|--------|
| <ul style="list-style-type: none"> Smoothing | None Low Average High | None | | |
| <ul style="list-style-type: none"> Reference junction (reference to the cold junction) | None Internal Reference temperature value dynamic | Internal | Static | Module |

- 1) If you use the module in ER-1/ER-2, you must set this parameter to “No” because the interrupt lines are not available in ER-1/ER-2.
- 2) Only in the CC (central controller) is it possible to start up the analog modules with the default settings.
- 3) The limit values must be within the temperature range of the connected sensor.
- 4) Valid for the format of the output temperature and the dynamic reference temperature

Smoothing of the Measured Values

You will find information that is generally applicable to the smoothing of analog values in Section 5.6.

The cycle time of the module is a constant in the SM 431; AI 8 × 16 Bit that is not dependent on the number of channels that are enabled. It therefore has no effect on the step response, which is defined by the parameter assignment of interference frequency suppression and smoothing.

Step Response

Table 5-75 How Response Times Depend on the Parameterized Interference Frequency Suppression and Smoothing of the SM 431; AI 8 × 16 Bit

| Interference Frequency Suppression in Hz | Response Time in ms with Parameterized Smoothing: | | | |
|--|---|------|---------|------|
| | None | Low | Average | High |
| 10 | 100 | 200 | 1600 | 3200 |
| 50 | 20 | 40 | 320 | 640 |
| 60 | 16.7 | 33.3 | 267 | 533 |
| 400 | 10 | 20 | 160 | 320 |

The following figures illustrate the contents of Table 5-75. They show the response time required for a step response before the smoothed analog value is almost applied to 100%. The figures apply to every change of signal at an analog input.

Step Response at an Interference Frequency Suppression of 10 Hz

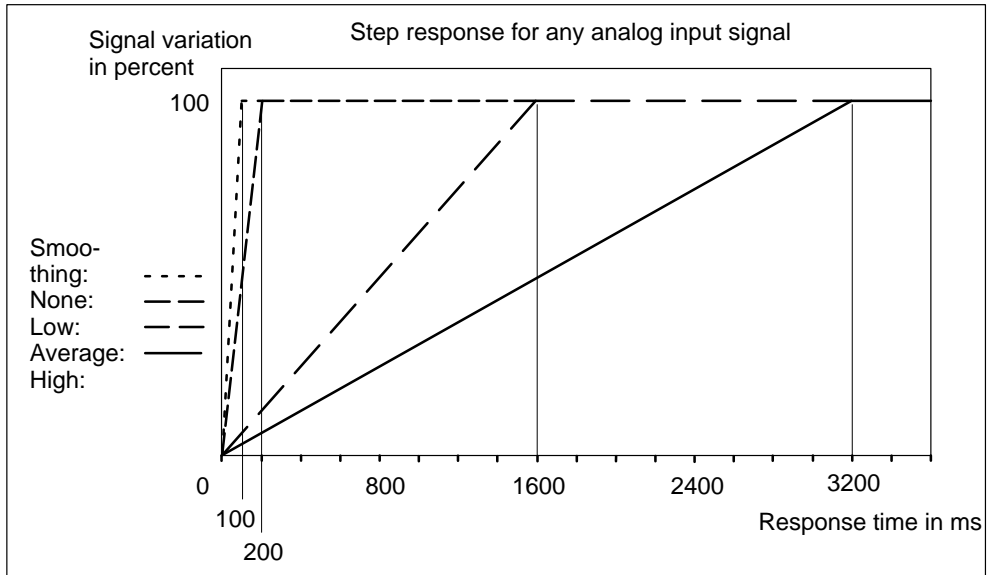

Figure 5-43 Step Response at 10 Hz Interference Frequency Suppression of the SM 431; AI 8 × 16 Bit

Step Response at an Interference Frequency Suppression of 50 Hz

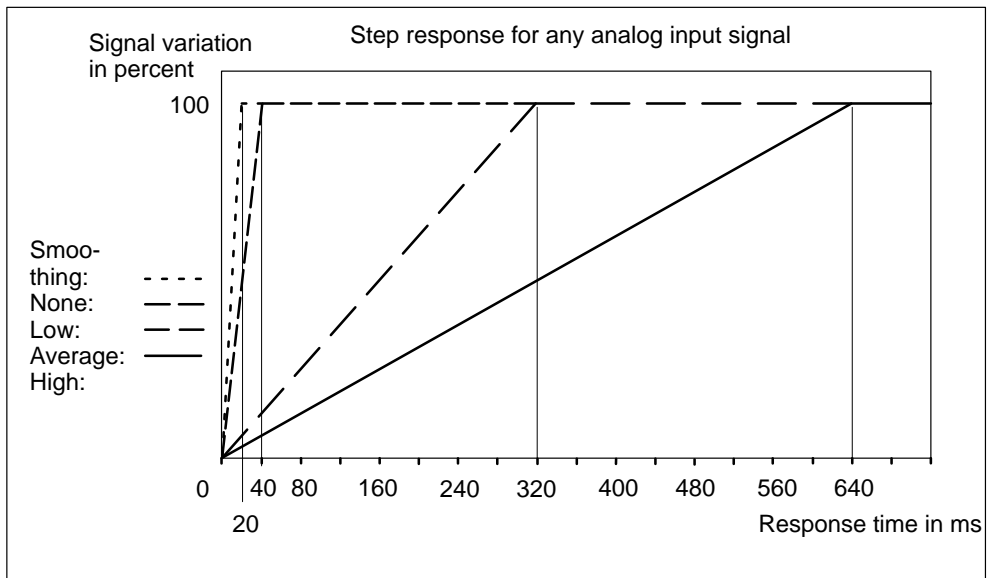

Figure 5-44 Step Response at 50 Hz Interference Frequency Suppression of the SM 431; AI 8 × 16 Bit

Step Response at an Interference Frequency Suppression of 60 Hz

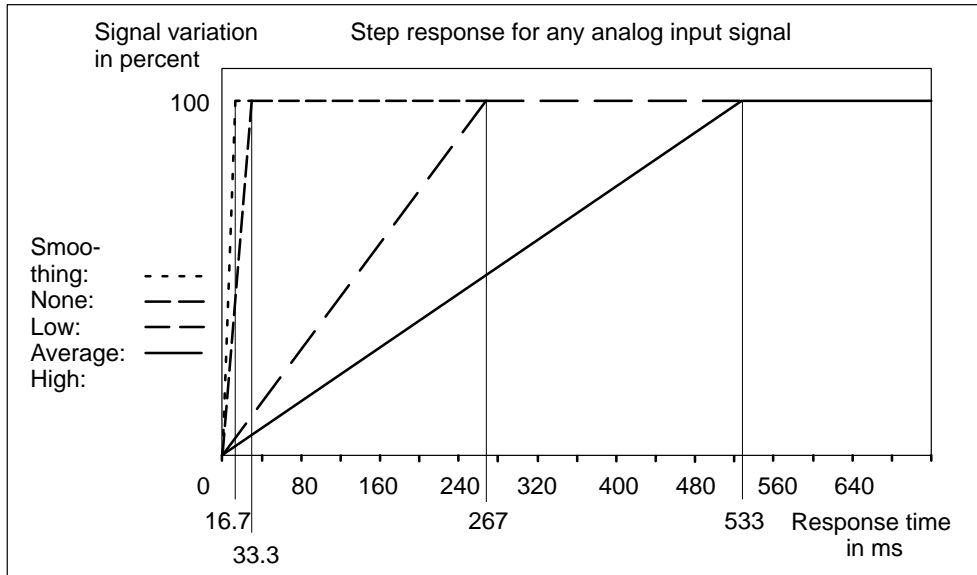

Figure 5-45 Step Response at 60 Hz Interference Frequency Suppression of the SM 431; AI 8 × 16 Bit

Step Response at an Interference Frequency Suppression of 400 Hz

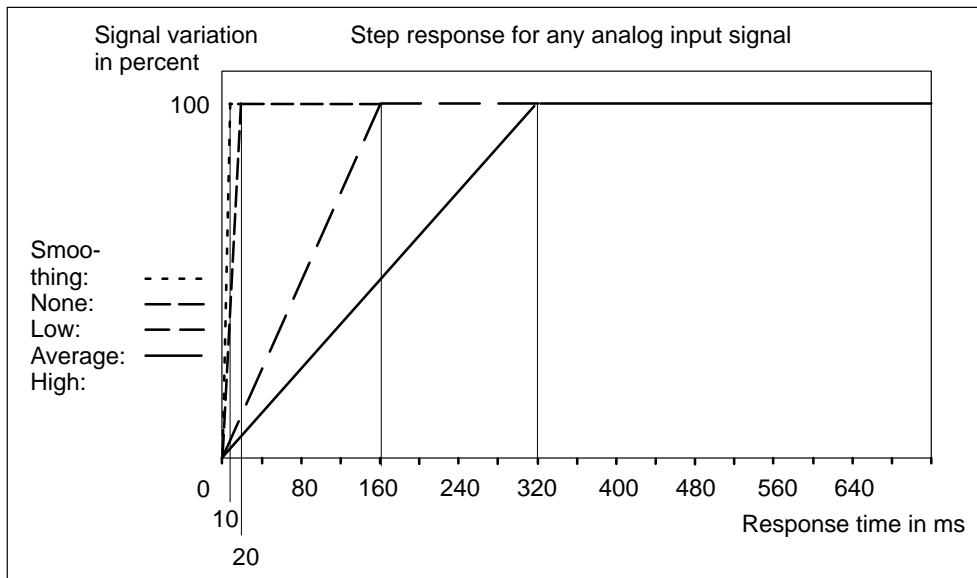

Figure 5-46 Step Response at 400 Hz Interference Frequency Suppression of the SM 431; AI 8 × 16 Bit

Displaying Parameter Assignment Errors

The SM 431; AI 8 × 16 Bit has diagnostics capability. Below you will find an overview of the displays that are possible for modules with parameter assignment errors.

Table 5-76 Diagnostic Information of the SM 431; AI 8 × 16 Bit

| Incorrect Parameter Assignment | Possible Display | Explanation |
|--------------------------------|--|--|
| Of the module | <ul style="list-style-type: none"> • Module malfunction • Internal malfunction • Wrong parameters • Module not parameterized. | You can find an explanation of the diagnostic information in Tables 4-8 and 5-47 on Pages 4-10 and 5-65. |
| Affecting certain channels | <ul style="list-style-type: none"> • Module malfunction • Internal malfunction • There is a channel error • Wrong parameters • Channel information available • Vector channel error • Channel parameter assignment error • User calibration doesn't correspond to the parameter assignment | |

5.24.2 Measuring Methods and Measuring Ranges of the SM 431; AI 8 × 16 Bit

Measuring Methods

You can set the following measuring methods for the input channels:

- Voltage measurement
- Current measurement
- Temperature measurement

You specify the setting by means of the “Measuring Type” parameter in *STEP 7*.

Unused Channels

Disable the “Measuring Type” parameter for unused channels. In this way you shorten the scan time of the module.

Measuring Ranges

You set the measuring ranges by means of the “Measuring Range” parameter in *STEP 7*.

Table 5-77 Measuring Ranges of the SM 431; AI 8 x 16 Bit

| Method Selected | Measuring Range | Description |
|---|--|---|
| U: Voltage | ± 25 mV ± 50 mV ± 80 mV ± 100 mV ± 250 mV ± 500 mV ± 1 V ± 2.5 V ± 5 V ± 10 V 1 to 5 V | You will find the digitized analog values in Section 5.3.1 in the voltage measuring range |
| 4DMU: Current (four-wire transmitter) | ± 3.2 mA ± 5 mA ± 10 mA ± 20 mA 0 to 20 mA 4 to 20 mA | You will find the digitized analog values in Section 5.3.1 in the current measuring range |
| TC-L: Thermocouple (linear) (temperature measurement) | Type B Type N Type E Type R Type S Type J Type L Type T Type K Type U | You will find the digitized analog values in Section 5.3.1 in the temperature range |

Default Settings

The default settings of the module in *STEP 7* are “Thermocouple (linear)” for the measuring method and “Type J” for the measuring range. You can use this combination of measuring method and measuring range without parameterizing the SM 431; AI 8 × 16 Bit in *STEP 7*.

5.25 Analog Output Module SM 432; AO 8 × 13 Bit; (6ES7432-1HF00-0AB0)

Characteristics

The SM 432; AO 8 x 13 Bit has the following features:

- 8 outputs
- The individual output channels can be programmed as
 - Voltage outputs
 - Current outputs
- 13-bit resolution
- Analog section Isolated to CPU and load voltage
- Maximum permissible common mode voltage between the channels and the channels against M_{ANA} is 3 VDC

Block Diagram of the SM 432; AO 8 x 13 Bit

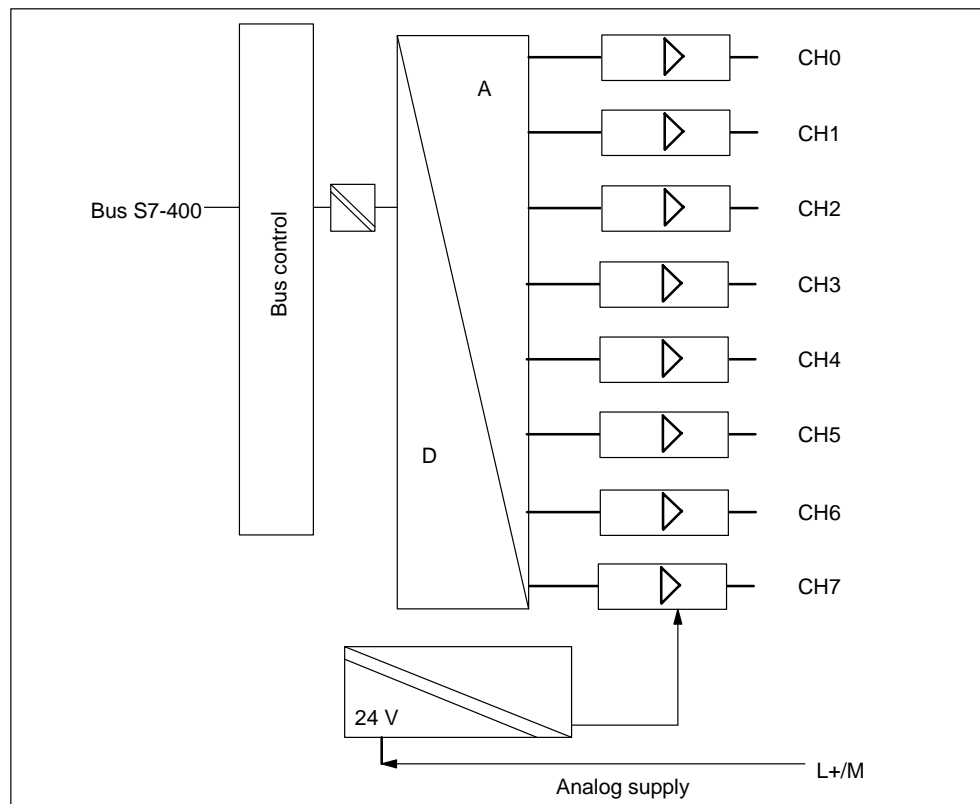

Figure 5-47 Block Diagram of the SM 432; AO 8 x 13 Bit

Terminal Assignment Diagram of the SM 432; AO 8 x 13 Bit

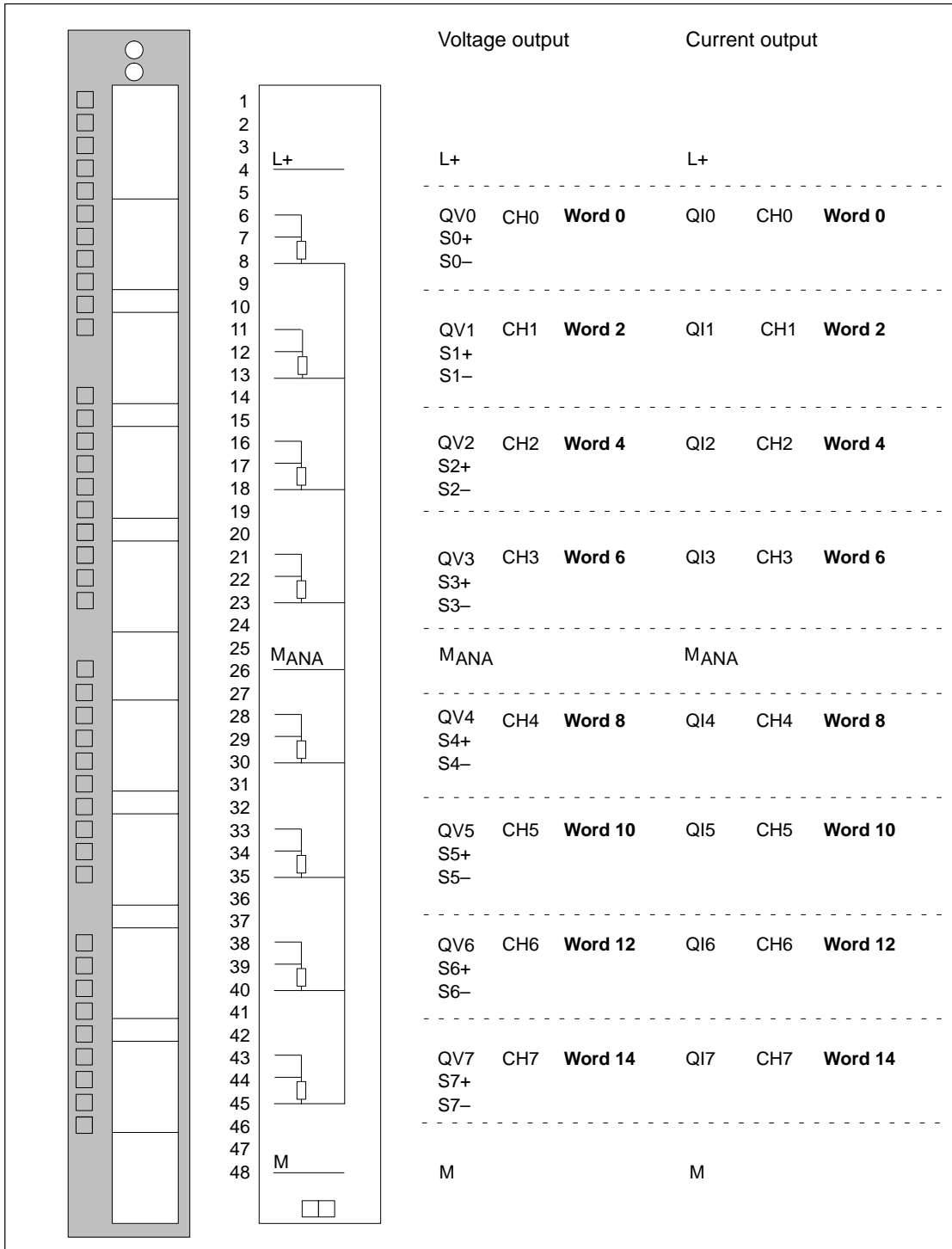

Figure 5-48 Terminal Assignment Diagram of the SM 432; AO 8 x 13 Bit

Technical Specifications of the SM 432; AO 8 x 13 Bit

| Programming package | | Analog Value Generation | |
|---|----------------------------|---|-------------------------------|
| Associated programming package | As of STEP 7 V 2.0 package | Resolution including sign | 13 bits |
| Dimensions and Weight | | Conversion time (per channel) | |
| Dimensions W × H × D (in millimeters) | 25 × 290 × 210 | <ul style="list-style-type: none"> In the ranges 1 V to 5 V and 4 mA to 20 mA | 420 μs |
| Weight | Approx. 650 g | <ul style="list-style-type: none"> In all ranges | 300 μs |
| Data for Specific Module | | Basic response time of module (all channels enabled) | |
| Number of outputs | 8 | <ul style="list-style-type: none"> In the ranges 1 V to 5 V and 4 mA to 20 mA | 3.36 ms |
| Length of cable | | <ul style="list-style-type: none"> In all the other ranges | 2.4 ms |
| <ul style="list-style-type: none"> Shielded | Max. 200 m | Settling time | |
| Voltages, Currents, Potentials | | <ul style="list-style-type: none"> For resistive load For capacitive load For inductive load | 0.1 ms 3.5 ms 0.5 ms |
| Supply voltage of the electronics L+ | 24 VDC | Suppression of Interference, Limits of Error | |
| Rated load voltage L+ | 24 VDC | Interference voltage suppression for $f = n \times (f_1 \pm 1\%)$, ($f_1 =$ interference frequency) $n=1.2 \dots$ | |
| <ul style="list-style-type: none"> Reverse polarity protection | Yes | <ul style="list-style-type: none"> Common-mode interference ($U_{CM} < AC 3 V_{SS}/50 Hz$) | >60 dB |
| Isolation | | Crosstalk between the outputs | > 40 dB |
| <ul style="list-style-type: none"> Between channels and backplane bus | Yes | Operational limit (in the entire temperature range, with reference to the output range) | |
| <ul style="list-style-type: none"> Between the channels | No | <ul style="list-style-type: none"> Voltage outputs | |
| <ul style="list-style-type: none"> Between channels and load voltage L+ | Yes | <ul style="list-style-type: none"> – ± 10 V – 0 V to 10 V – 1 V to 5 V | ± 0.5 % ± 0.5 % ± 0.5 % |
| Permitted potential difference | | <ul style="list-style-type: none"> Current outputs | |
| <ul style="list-style-type: none"> Between the outputs (E_{CM}) | 3 VDC | <ul style="list-style-type: none"> – ± 20 mA – 4 mV to 20 mV | ± 1% ± 1% |
| <ul style="list-style-type: none"> Between S– and M_{ANA} (U_{CM}) | 3 VDC | Basic error (operational limit at 25 °C, referred to the output range) | |
| <ul style="list-style-type: none"> Between M_{ANA} and $M_{internal}$ (U_{ISO}) | 75 VDC/60 VAC | <ul style="list-style-type: none"> Voltage outputs | |
| Insulation tested | | <ul style="list-style-type: none"> – ± 10 V – 0 V to 10 V – 1 V to 5 V | ± 0.5% ± 0.5% ± 0.5% |
| <ul style="list-style-type: none"> Between bus and L+/M | 2120 VDC | <ul style="list-style-type: none"> Current outputs | |
| <ul style="list-style-type: none"> Between bus and analog section | 2120 VDC | <ul style="list-style-type: none"> – ± 20 mA – 0 mA to 20 mA | ± 0.5% ± 0.5% |
| <ul style="list-style-type: none"> Between bus and chassis ground | 500 VDC | Temperature error (with reference to the output range) | ± 0.02% K |
| <ul style="list-style-type: none"> Between analog section and L+/M | 707 VDC | Linearity error (with reference to the output range) | ± 0.05% |
| <ul style="list-style-type: none"> Between analog section and chassis ground | 2120 VDC | | |
| <ul style="list-style-type: none"> Between L+/M and chassis ground | 2120 VDC | | |
| Current consumption | | | |
| <ul style="list-style-type: none"> From the backplane bus | Max. 150 mA | | |
| <ul style="list-style-type: none"> Power supply and load voltage L+ (with rated load) | Max. 400 mA | | |
| <ul style="list-style-type: none"> Power supply and load voltage L+ (no load) | Max. 200 mA | | |
| Power dissipation of the module | Typ. max. 9 W | | |

| | | | |
|--|---|---|---|
| Repeat accuracy (in the steady state at 25 °C, referred to the output range) | ± 0.05% | Destruction limit for voltages/ currents connected from outside | <ul style="list-style-type: none"> Voltage at outputs to M_{ANA} Max. 20 V continuous 75 V for 1 ms (cycle factor 1 : 20) Current Max. 40 mA continuous |
| Output ripple; band width 0 to 50 kHz (with reference to the output range) | ± 0.05% | | |
| Status, Interrupts, Diagnostics | | | |
| Interrupts | None | | |
| Diagnostic functions | None | | |
| Substitute value can be applied | No | | |
| Data for Selecting an Actuator | | | |
| Output ranges (rated values) | | | |
| • Voltage | ± 10 V 0 V to 10 V 1 V to 5 V | | |
| • Current | ± 20 mA 0 mA to 20 mA 4 mA to 20 mA | | |
| Load resistance (in the nominal range of the output) | | | |
| • For voltage outputs | Min. 1 kΩ | | |
| – capacitive load | Max. 1 μF | | |
| • For current outputs | Max. 500 Ω 600 Ω with reduced U _{CM} to < 1 V | | |
| – Inductive load | Max. 1 mH | | |
| Voltage outputs | | | |
| • Short-circuit protection | Yes | | |
| • Short-circuit current | Max. 30 mA | | |
| Current outputs | | | |
| • No-load voltage | Max. 19 V | | |
| | | Connection of actuators <ul style="list-style-type: none"> For voltage output <ul style="list-style-type: none"> – Two-conductor connection Possible, without compensation for circuit resistance – Four-conductor connection (measuring circuit) Possible For current output <ul style="list-style-type: none"> – Two-conductor connection Possible | |

5.25.1 Commissioning the SM 432; AO 8 × 13 Bit

Parameter

You will find a description of the general procedure for assigning parameters to analog modules in Section 5.7.

You will find an overview of the programmable parameters and their default values in Table 5-43, on page 5-42.

Assigning Parameters to Channels

You can configure each output channel of the SM 432; AO 8 × 13 Bit individually. You can thus assign different parameters to each output channel.

5.25.2 Output Ranges of the Analog Output Module SM 432; AO 8 × 13 Bit

Wiring the Analog Outputs

You can wire the outputs as voltage or current outputs, or disable them. You wire the outputs by means of the “Type of Output” parameter in *STEP 7*.

Unused Channels

To ensure that output channels of the SM 432; AO 8 × 13 Bit remain de-energized, you must disable the “Type of Output” parameter and leave the terminal open.

Output Ranges

You program the output ranges for voltage and current outputs in *STEP 7*.

Table 5-78 Output Ranges of the Analog Output Module SM 432; AO8 × 13 Bit

| Selected Type of Output | Output Range | Description |
|-------------------------|-------------------------------------|---|
| Voltage | 1 to 5 V 0 to 10 V ± 10 V | You will find the digital analog values in Section 5.3.2 in the voltage and current output ranges |
| Current | 0 to 20 mA 4 to 20 mA ± 20 mA | |

Default Settings

The default settings of the module are “Voltage” for the output type and “± 10 V” for the output range. You can use this combination of output type and output range without parameterizing the SM 432; AO 8 × 13 Bit in *STEP 7*.

Interface Modules

6

Chapter Overview

| Section | Description | Page |
|---------|---|------|
| 6.1 | Common Features of the Interface Modules | 6-2 |
| 6.2 | The Interface Modules IM 460-0; (6ES7460-0AA00-0AB0, 6ES7460-0AA01-0AB0) and IM 461-0; (6ES7461-0AA00-0AA0, 6ES7461-0AA01-0AA0) | 6-7 |
| 6.3 | The Interface Modules IM 460-1; (6ES7460-1BA00-0AB0, 6ES7460-1BA01-0AB0) and IM 461-1; (6ES7461-1BA00-0AA0, 6ES7461-1BA01-0AA0) | 6-10 |
| 6.4 | The Interface Modules IM 460-3; (6ES7460-3AA00-0AB0, 6ES7460-3AA01-0AB0) and IM 461-3; (6ES7461-3AA00-0AA0, 6ES7461-3AA01-0AA0) | 6-14 |
| 6.5 | The Interface Modules IM 460-4; (6ES7460-4AA01-0AB0, IM 461-4; (6ES7461-4AA01-0AA0) | 6-18 |

You will find a description of the IM 463-2 in Chapter 7.

6.1 Common Features of the Interface Modules

Function

Interface modules (a send IM and a receive IM) are required if one or more expansion units (EU) are to be connected to a central controller (CC). This configuration is described in the *Installation Manual*, Chapter 4.

Configuration

Interface modules must always be used together. The send modules (send IMs) are inserted in the CC, whilst the corresponding receive modules (receive IMs) are plugged into the series-connected EU.

Table 6-1 Interface Modules of the S7-400

| Partner | Areas of Application |
|----------|---|
| IM 460-0 | Send IM for local link without PS transfer; with communication bus |
| IM 461-0 | Receive IM for local link without PS transfer; with communication bus |
| IM 460-1 | Send IM for local link with PS transfer; without communication bus |
| IM 461-1 | Receive IM for local link with PS transfer; without communication bus |
| IM 460-3 | Send IM for remote link up to 102 m; with communication bus |
| IM 461-3 | Receive IM for remote link up to 102 m; with communication bus |
| IM 460-4 | Send IM for remote link up to 605 m; without communication bus |
| IM 461-4 | Receive IM for remote link up to 605 m; without communication bus |

Overview of the Properties of the Connections

Note the rules for connections in the section after next.

| | Local connection | | Remote connection | |
|--|------------------|-------|-------------------|-------|
| | 460-0 | 460-1 | 460-3 | 460-4 |
| Send IM | 460-0 | 460-1 | 460-3 | 460-4 |
| Receive IM | 461-0 | 461-1 | 461-3 | 461-4 |
| Max. number of connectable EMs per chain | 4 | 1 | 4 | 4 |
| Max. distance | 3 m | 1.5 m | 102.25 m | 605 m |
| 5 V transfer | No | Yes | No | No |
| Max. current transfer per interface | – | 5 A | – | – |
| Communication bus transmission | Yes | No | Yes | No |

Connection possibilities for central racks and expansion racks

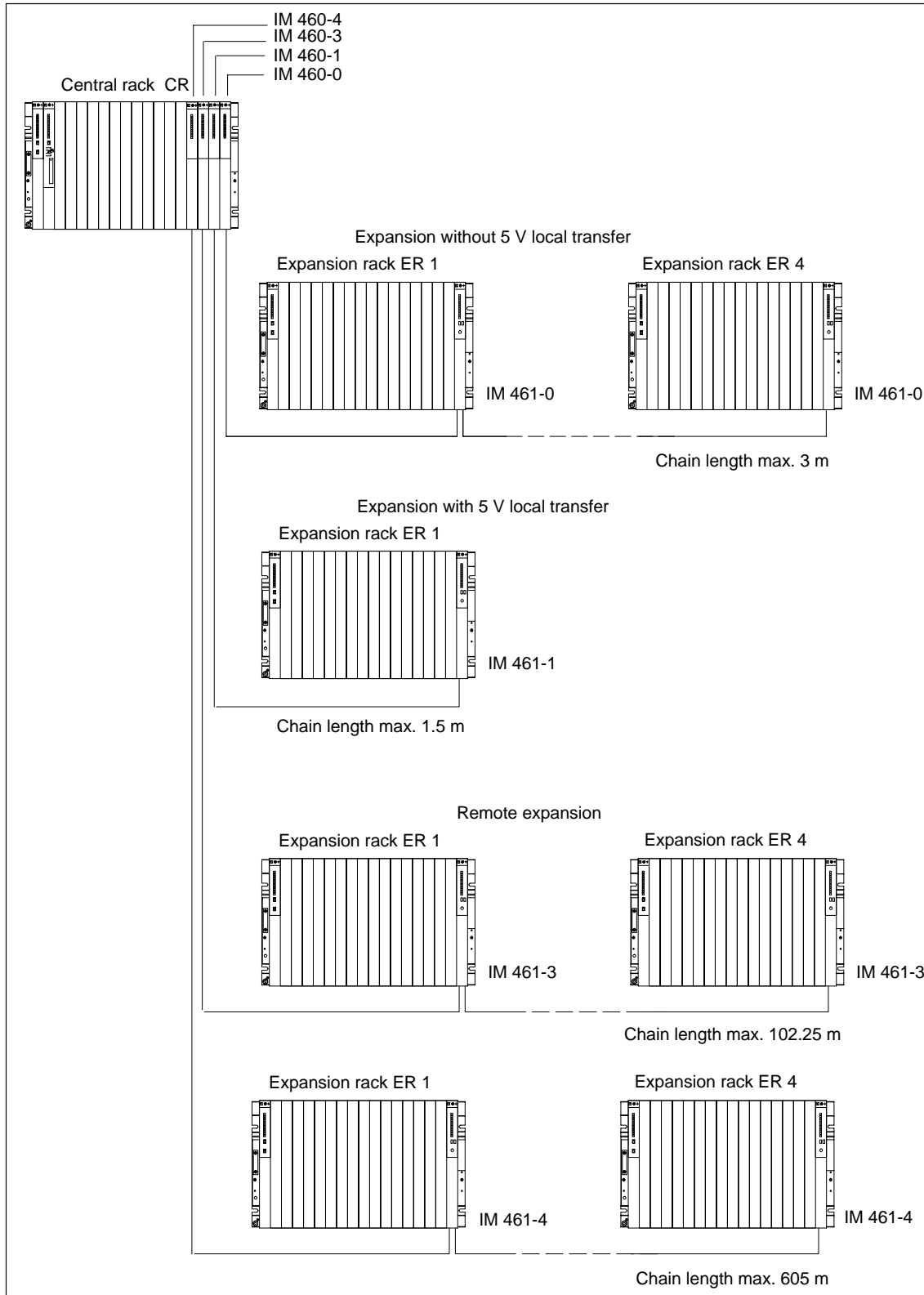

Rules for Connection

When you connect a central rack to expansion racks, you must observe the following rules:

- You can connect up to 21 ERs of the S7-400 to one CR.
- The ERs are assigned numbers to identify them. The rack number must be set on the coding switch of the receive IM. Any rack number between 1 and 21 may be assigned. Numbers must not be duplicated.
- You may insert up to six send IMs in one CR. However, only two send IMs with 5 V transfer are allowed in one CR.
- Each chain connected to the interface of a send IM can comprise up to four ERs (without 5 V transfer) or one ER (with 5 V transfer).
- The exchange of data via the communication bus is limited to 7 racks, meaning the CR and ER numbers 1 to 6.
- The maximum (total) cable lengths specified for the type of connection must not be exceeded.

| Connection type | Maximum (total) line length |
|---|-----------------------------|
| Local connection with 5 V transfer via IM 460-1 and IM 461-1 | 1.5 m |
| Local connection without 5 V transfer via IM 460-0 and IM 461-0 | 3 m |
| Remote connection via IM 460-3 and IM 461-3 | 102.25 m |
| Remote connection via IM 460-4 and IM 461-4 | 605 m |

Terminator

The bus must be terminated in the last EU of a line. To do this, plug in the appropriate terminator in the lower front connector of the receive IM in the last EU of the line. Unused front connectors in a send IM do not have to be terminated. The IM 461-1 with the order number 6ES7 461-1BA01-0AA0 does not require a terminator.

Table 6-2 Terminators for the Receive IMs

| Receive IM | Terminator |
|------------|--------------------|
| IM 461-0 | 6ES7461-0AA00-7AA0 |
| IM 461-1 | 6ES7461-1BA00-7AA0 |
| IM 461-3 | 6ES7461-3AA00-7AA0 |
| IM 461-4 | 6ES7461-4AA00-7AA0 |

The following figure shows you a typical configuration with send IMs, receive IMs and terminators.

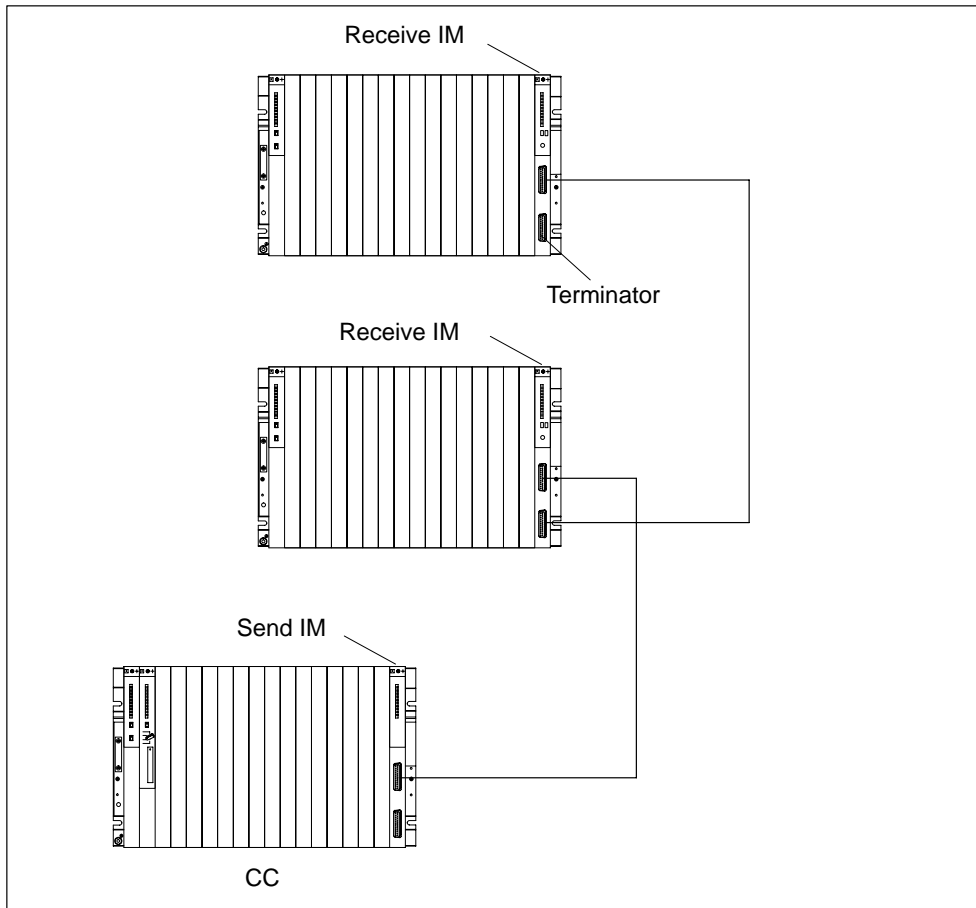

Figure 6-1 Example: Configuration with Send IMs, Receive IMs and Terminators

Connecting Cable

Precut cables are available in different fixed lengths for connecting the individual interface modules. (See Appendix C: Accessories and Spare Parts)

Table 6-3 Connecting Cable for Interface Modules

| Interface Modules | Connecting Cable |
|--|--|
| IM 460-0 and IM 461-0 IM 460-3 and IM 461-3 | 6ES7468-1... (P bus and communication bus are transferred) |
| IM 460-1 and IM 461-1 | 6ES7468-3... (P bus is transferred; mounting rack is supplied with current via the IM) |
| IM 460-4 and IM 461-4 | 6ES7468-1... |

Installation and Removal of the Modules During Operation

Please read the following warning on the insertion and removal of the interface modules and associated connecting cables.



Caution

Data may be lost or corrupted.

Removing or inserting the interface modules and/or their associated connecting cables under voltage can result in the loss or corruption of data.

Switch off the power supply modules to the CC and EUs you are working on before you carry out any changes.

Feeding in External Backup Voltage to the “EXT.-BATT.” Socket (Not Possible in Modules as of Order Number -0AA01-)

When changing the battery in the power supply modules of the S7-400, you can ensure uninterruptible backup in the CC if you apply between 5 VDC and 15 VDC to the “EXT.-BATT.” socket of the CPU. This only provides backup power to the CC.

You can achieve corresponding backup in an EU in the case of the following receive IMs by applying between 5 VDC and 15 VDC to the “EXT.-BATT.” socket.

- IM 461-0 6ES7461-0AA00-0AA0
- IM 461-1 6ES7461-1BA00-0AA0
- IM 461-3 6ES7461-3AA00-0AA0

The “EXT.-BATT.” input has the following features:

- Reverse polarity protection
- A short-circuit current limit of 20 mA

To provide an incoming supply at the “EXT.-BATT” socket, you need a connecting cable with a 2.5 mm \varnothing jack, as illustrated in the following figure. Note the polarity of the jack.

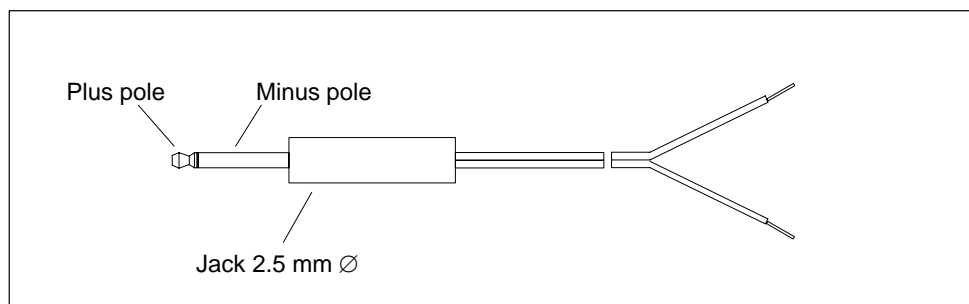

6.2 The Interface Modules

IM 460-0; (6ES7460-0AA00-0AB0, 6ES7460-0AA01-0AB0) and IM 461-0; (6ES7461-0AA00-0AA0, 6ES7461-0AA01-0AA0)

Position of the Operator Controls and Indicators of the IM 460-0 and IM 461-0

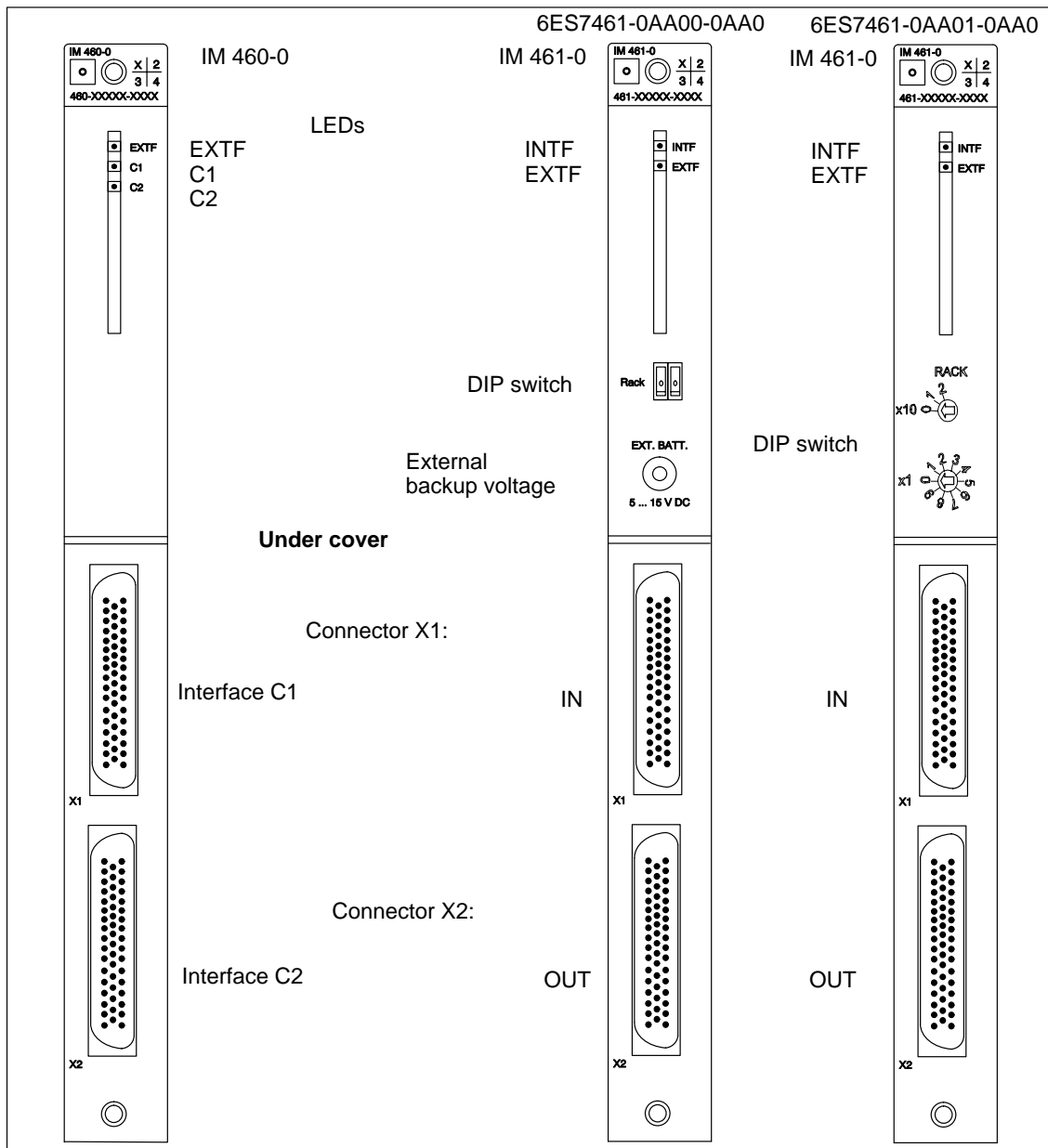

Figure 6-2 Position of the Operator Controls and Indicators of the IM 460-0 and IM 461-0

Function

The interface module pair IM 460-0 (send IM) and IM 461-0 (receive IM) are used for a local link. The communication bus is transferred at the full transmission rate.

Parameter Assignment for the Mounting Rack Number

Using the DIP switch on the front panel of the module, you must set the number of the mounting rack in which the receive IM is installed. The permitted range is 1 to 21.

Setting/Changing the Number

Proceed as follows:

1. Put the switch of the power supply module in the EU in which you want to make a change in the position  (Output voltage 0 V).
2. Enter the number using the DIP switch.
3. Switch the power supply module on again.

Operator Controls and Indicators on the Send IM

| | |
|----------------------------|--|
| EXTF LED (red) | Lights up in the event of an external fault Line 1 or line 2 is faulty (terminator missing or broken cable) |
| C1 LED (green) | Line 1 (via front connector X1, connection 1) is correct. |
| C1 LED (flashing green) | An EU in the line is not ready for operation because <ul style="list-style-type: none">• The power supply module is not switched on or• A module has not yet completed the initialization process |
| C2 LED (green) | Line 2 (via front connector X2, connection 2) is correct. |
| C2 LED (flashing green) | An EU in the line is not ready for operation because <ul style="list-style-type: none">• The power supply module is not switched on or• A module has not yet completed the initialization process |
| Front connectors X1 and X2 | Connector (output) for line 1 and line 2 X1 = upper front connector; X2 = lower front connector |

Operator Controls and Indicators of the Receive IM

| | |
|---|--|
| INTF LED (red) | Lights up if a rack number > 21 or = 0 was set. Lights up if you have changed the rack number under voltage. |
| EXTF LED (red) | Lights up in the event of an external fault (line fault, for example, if the terminator is not inserted or if a module has not yet completed the initialization process). |
| DIP switch | DIP switch to set the number of the mounting rack. |
| Socket for external backup voltage EXT.BATT. | On the IM 461-0 (order number 6ES7461-0AA00-0AA0) you can connect external backup voltage (5 V to 15 V) or central backup (see <i>Installation Manual</i> , Chapter 9) to this socket when you want to replace the mounting rack power supply. This will ensure backup of the corresponding EU without interruption. If you use this IM in a cabinet, you should, for reasons of space, use an angled connector for the incoming supply. |
| Front connector X1 | Upper connector (input) for the connecting cable from the previous interface module. |
| Front connector X2 | Lower connector (output) for the connecting cable to the next interface module or for the terminator. |

Technical Specifications of the IM 460-0 and IM 461-0

| | |
|--|---|
| Maximum line length (total) | 3 m, 5 m in the IM 461-0 with the order number 6ES7461-0AA01-0AA0, in the IM 461-0 with the order number 6ES7461-0AA00-0AA0 as of version A4, in the IM 460-0 with the order number 6ES7460-1AA01-0AA0 and in the IM 460-0 with the order number 6ES7460-1AA00-0AA0 as of version A5 |
| Dimensions W x H x D (mm) | 25 x 290 x 280 |
| Weight <ul style="list-style-type: none"> • IM 460-0 • IM 461-0 | 600 g 610 g |
| Current consumption from the S7-400 bus 5 VDC <ul style="list-style-type: none"> • IM 460-0 • IM 461-0 | Typ. 130 mA Max. 140 mA Typ. 260 mA Max. 290 mA |
| Power loss <ul style="list-style-type: none"> • IM 460-0 • IM 461-0 | Typ. 650 mW Max. 700 mW Typ. 1300 mW Max. 1450 mW |
| Terminator | 6ES7461-0AA00-7AA0 |
| Backup current | No |

6.3 The Interface Modules

IM 460-1; (6ES7460-1BA00-0AB0, 6ES7460-1BA01-0AB0) and IM 461-1; (6ES7461-1BA00-0AA0, 6ES7461-1BA01-0AA0)

Position of the Operator Controls and Indicators of the IM 460-1 and IM 461-1

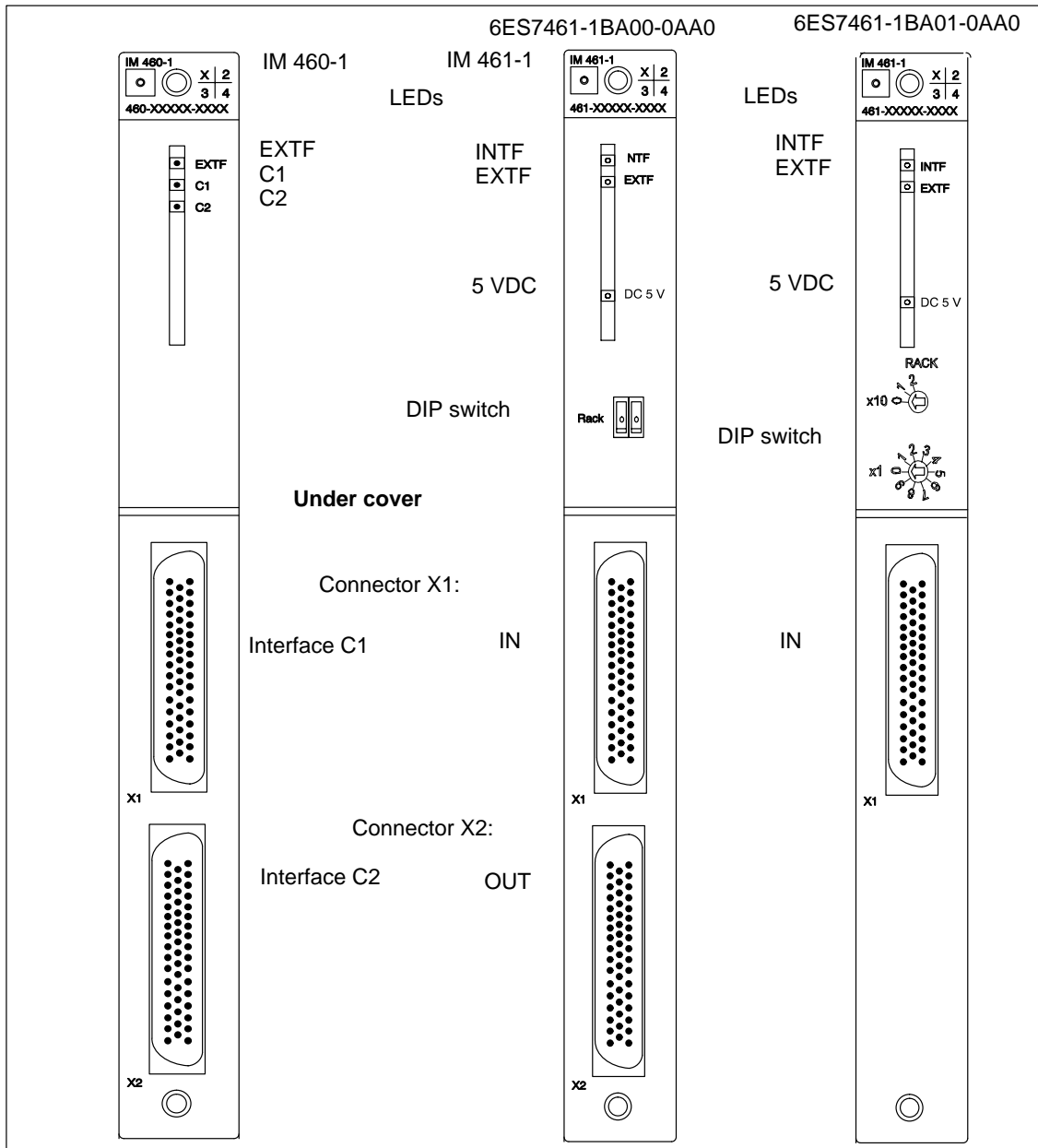

Figure 6-3 Position of the Operator Controls and Indicators of the IM 460-1 and IM 461-1

Function

The interface module pair IM 460-1 (send IM) and IM 461-1 (receive IM) are used for a local link (up to a maximum 1.5 m in total). A 5 V supply voltage is also transferred with these interface modules. Please particularly remember the following points:

- The current requirements of the module plugged into the EU must not exceed 5 V/5 A.
- You can only connect one EU per line.
- The modules in this mounting rack are not supplied with 24 V and are not backed up.
- The communication bus is not transferred with the interface module pair IM 460-1 and IM 461-1.
- You must not use a power supply module in the EU.

Note

If you connect an EU via a local link with 5 V transmission, ungrounded operation is prescribed for the EU (see *Installation Manual*, Chapter 4)

Parameter Assignment for the Mounting Rack Number

Using the DIP switch on the front panel of the module, you must set the number of the mounting rack in which the receive IM is installed. The permitted range is 1 to 21.

Setting/Changing the Number

Proceed as follows:

1. Put the power supply module in the CC into the position  (Output voltage 0 V).
2. Enter the number using the DIP switch.
3. Switch the power supply module on again.

Operator Controls and Indicators on the Send IM

| | |
|----------------------------|---|
| EXTF LED (red) | Lights up in the event of an external fault Line 1 or line 2 is faulty (terminator missing or open circuit) |
| C1 LED (green) | Line 1 (via front connector X1, connection 1) is correct. |
| C1 LED (flashing green) | A module has not yet completed the initialization process |
| C2 LED (green) | Line 2 (via front connector X2, connection 2) is correct. |
| C2 LED (flashing green) | A module has not yet completed the initialization process |
| Front connectors X1 and X2 | Connector (output) for line 1 and line 2 X1 = upper front connector; X2 = lower front connector |

Operator Controls and Indicators of the Receive IM

| | |
|--------------------|---|
| INTF LED (red) | Lights up if a rack number > 21 or = 0 was set. Lights up if you have changed the rack number under voltage. |
| EXTF LED (red) | Lights up in the event of an external fault (line fault, for example, if the terminator is not inserted or if a module has not yet completed the initialization process, but not when the CC is switched off) |
| 5 VDC (green) | Power supply in the EU is correct. |
| DIP switch | DIP switch to set the number of the mounting rack. |
| Front connector X1 | Upper connector (input) for the connecting cable from the previous interface module. |
| Front connector X2 | Lower connector (output) for terminator. The front connector X2 is no longer required for the IM 461-1 (order number 6ES7 461-1BA01-0AA0). The terminator (6ES7461-1BA00-7AA0) previously required is now integrated in the module. |



Caution

Modules can be damaged.

If you want to connect an EU via the IM 461-1 interface module and use a power supply module in this EU, you might damage the modules.

Don't use a power supply module in an EU that you want to connect to the CC via the IM 461-1 interface module.

Technical Specifications of the IM 460-1 and IM 461-1

| | |
|--|--|
| Maximum line length (total) | 1.5 m |
| Dimensions W x H x D (mm) | 25 x 290 x 280 |
| Weight <ul style="list-style-type: none"> • IM 460-1 • IM 461-1 | 600 g 610 g |
| Current consumption from the S7-400 bus 5 VDC <ul style="list-style-type: none"> • IM 460-1 • IM 461-1 | Typ. 50 mA max. 85 mA Typ. 120 mA max. 100 mA |
| Power loss <ul style="list-style-type: none"> • IM 460-1 • IM 461-1 | Typ. 250 mW max. 425 mW Typ. 500 mW max. 600 mW |
| Terminator | 6ES7 461-1BA00-7AA0 |
| Power supply for EU | 5 V/5 A per line |
| Backup current | No |

6.4 The Interface Modules

IM 460-3; (6ES7460-3AA00-0AB0, 6ES7460-3AA01-0AB0) and IM 461-3; (6ES7461-3AA00-0AA0, 6ES7461-3AA01-0AA0)

Position of the Operator Controls and Indicators of the IM 460-3 and IM 461-3

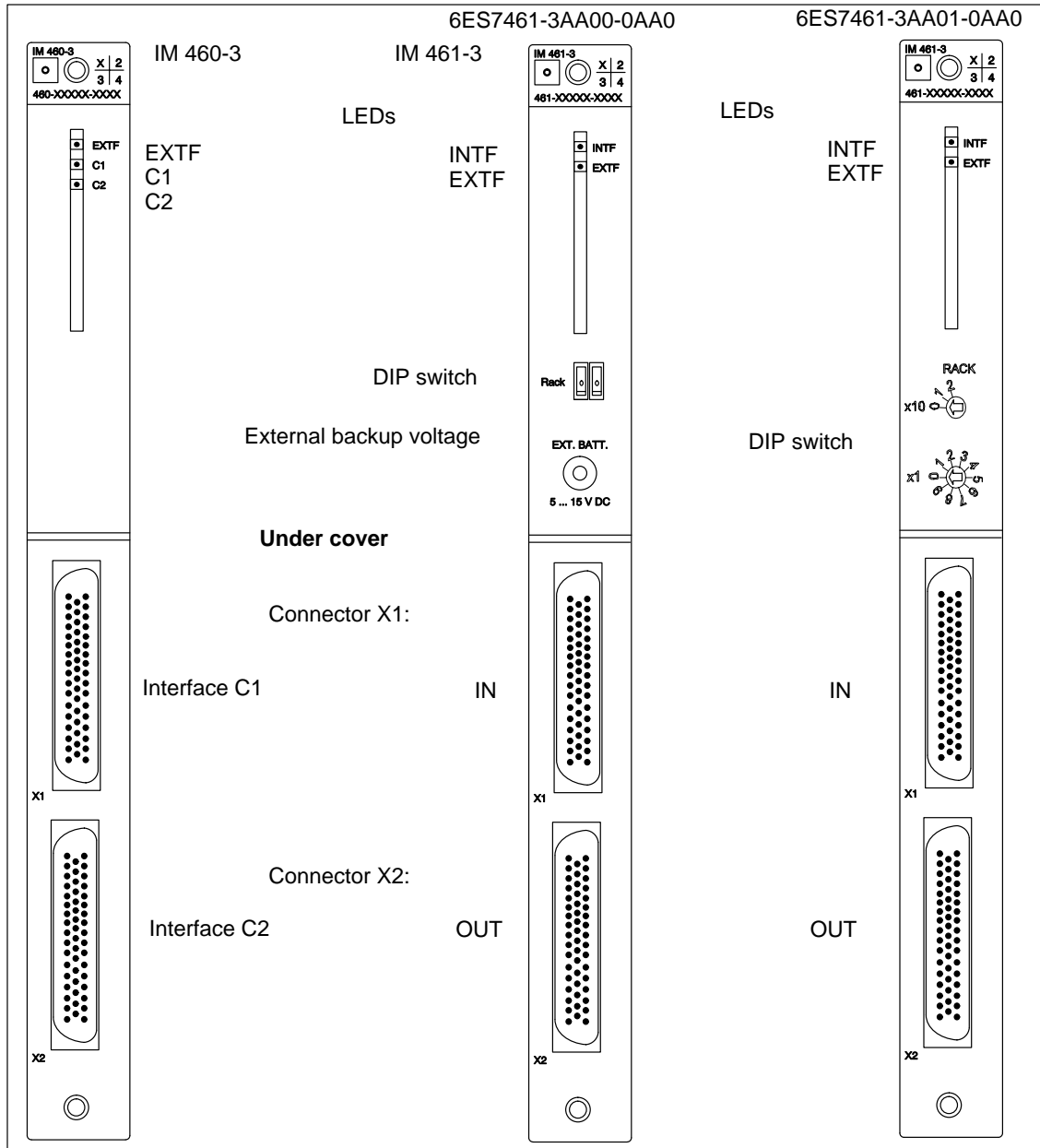

Figure 6-4 Position of the Operator Controls and Indicators of the IM 460-3 and IM 461-3

Function

The interface module pair IM 460-3 (send IM) and IM 461-3 (receive IM) are used for a remote link of up to a maximum 102 m (exactly: 100 m plus inputs/outputs of 0.75 m in the line). The communication bus is transferred at the full transmission rate.

Parameterization

Using the DIP switch on the front panel of the module, you must set the number of the mounting rack that the receive IM is installed on. The permitted range is 1 to 21.

If required, you can change the distance setting for the line on the programming device using STEP 7.

The default setting for the distance is 100 m.

Ensure that the distance corresponds as closely as possible to the current length (the sum of all the connecting cables per line) as this will accelerate data transmission.

Note

The distance set must always be longer than the actual length of cable per line.

Setting/Changing the Number

Proceed as follows:

1. Put the switch of the power supply module in the EU in which you want to make a change in the position  (Output voltage 0 V).
2. Enter the number using the DIP switch.
3. Switch the power supply module on again.

Operator Controls and Indicators on the Send IM

| | |
|-------------------------|---|
| EXTF LED (red) | Lights up in the event of an external fault Line 1 or line 2 is faulty (terminator missing or broken cable) |
| C1 LED (green) | Line 1 (via front connector X1, connection 1) is correct. |
| C1 LED (flashing green) | An EU in the line is not ready for operation because <ul style="list-style-type: none"> The power supply module is not switched on or A module has not yet completed the initialization process |
| C2 LED (green) | Line 2 (via front connector X2, connection 2) is correct. |
| C2 LED (flashing green) | An EU in the line is not ready for operation because <ul style="list-style-type: none"> The power supply module is not switched on or A module has not yet completed the initialization process |

Operator Controls and Indicators of the Receive IM

| | |
|---|---|
| INTF LED (red) | Lights up if a rack number > 21 or = 0 was set. Lights up if you have changed the rack number under voltage. |
| EXTF LED (red) | Lights up in the event of an external fault (line fault, for example, if the terminator is not inserted or if a module has not yet completed the initialization process, or if the CC is switched off) |
| DIP switch | DIP switch to set the number of the mounting rack. |
| Socket for external backup voltage EXT.BATT. | On the IM 461-3 (order number 6ES7461-3AA00-0AA0) you can connect an external backup voltage (5 V to 15 V) or a central backup to this socket when you want to replace the mounting rack power supply. This will ensure a backup of the corresponding EU without interruption. If you use the receive IM in a cabinet, you should, for reasons of space, use an angled connector for the incoming supply. |
| Front connector X1 | Upper connector (input) for the connecting cable from the previous interface module. |
| Front connector X2 | Lower connector (output) for the connecting cable to the next interface module or for the terminator. |

Technical Specifications of the IM 460-3 and IM 461-3

| | |
|--|--|
| Maximum line length (total) | 102 m |
| Dimensions W x H x D (mm) | 25 x 290 x 280 |
| Weight <ul style="list-style-type: none"> • IM 460-3 • IM 461-3 | 630 g 620 g |
| Current consumption from the S7-400 bus 5 VDC <ul style="list-style-type: none"> • IM 460-3 • IM 461-3 | Typ. 1350 mA Max. 1550 mA Typ. 590 mA Max. 620 mA |
| Power loss <ul style="list-style-type: none"> • IM 460-3 • IM 461-3 | Typ. 6750 mW Max. 7750 mW Typ. 2950 mW Max. 3100 mW |
| Terminator | 6ES7461-3AA00-7AA0 |
| Backup current | No |

6.5 The Interface Modules IM 460-4; (6ES7460-4AA01-0AB0) and IM 461-4; (6ES7461-4AA01-0AA0)

Position of the Operator Controls and Indicators of the IM 460-4 and IM 461-4

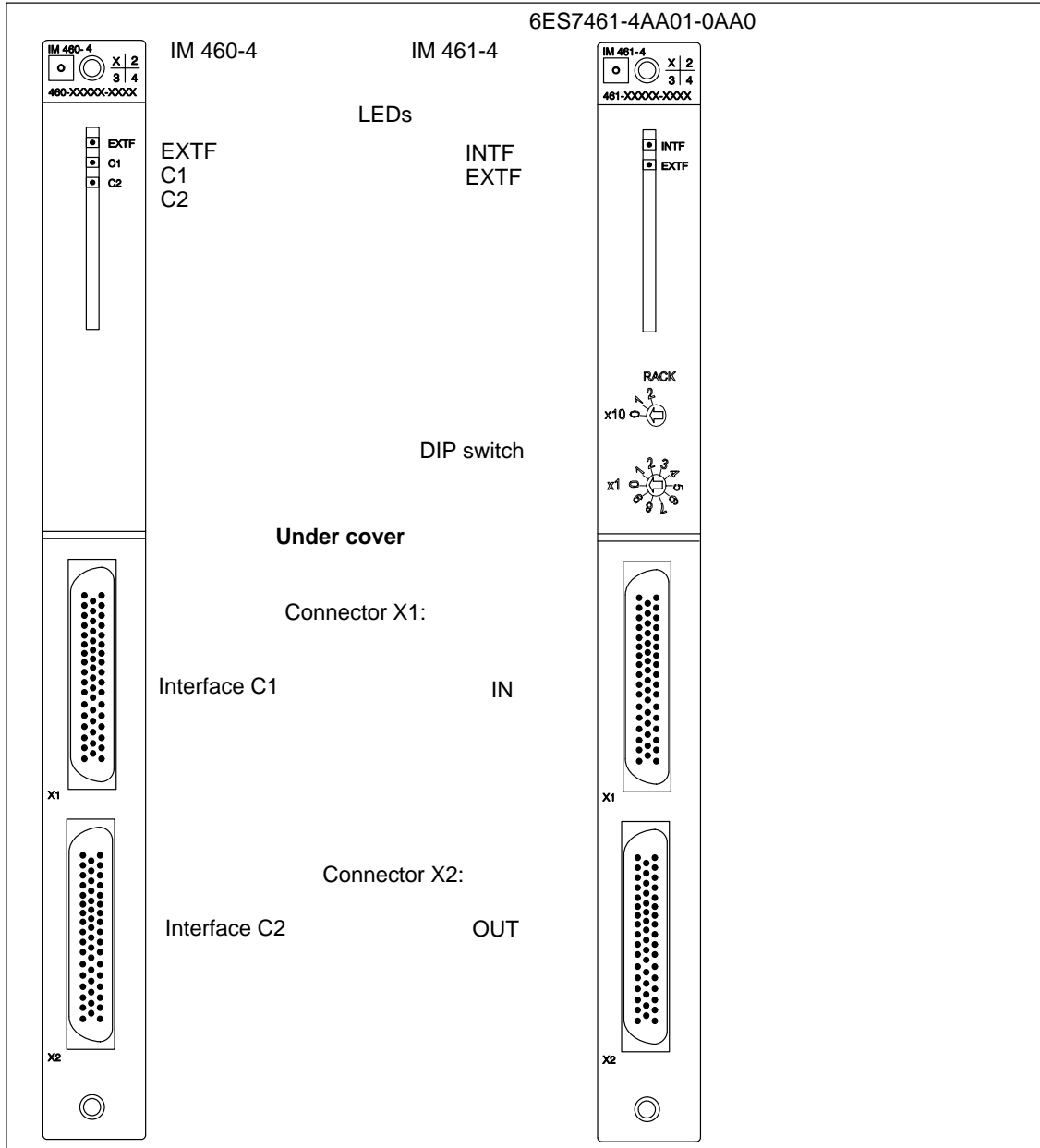

Figure 6-5 Position of the Operator Controls and Indicators of the IM 460-4 and IM 461-4

Function

The interface module pair IM 460-4 (send IM) and IM 461-4 (receive IM) are used for a remote link of up to a maximum 605 m (exactly: 600 m plus inputs/outputs of 1.5 m in the line).

Parameterization

Using the DIP switch on the front panel of the module, you must set the number of the mounting rack in which the receive IM is installed. The permitted range is 1 to 21.

If required, you can change the distance setting for the line on the programming device using STEP 7.

The default setting for the distance is 600 m.

Ensure that the distance corresponds as closely as possible to the current length (the sum of all the connecting cables per line) as this will accelerate data transmission.

Note

The distance set must always be longer than the actual length of cable per line.

Setting/Changing the Number

Proceed as follows:

1. Put the switch of the power supply module in the EU in which you want to make the change in the position ☹ (Output voltage 0 V).
2. Enter the number using the DIP switch.
3. Switch the power supply module on again.

Operator Controls and Indicators on the Send IM

| | |
|-------------------------|---|
| EXTF LED (red) | Lights up in the event of an external fault Line 1 or line 2 is faulty (terminator missing or broken cable) |
| C1 LED (green) | Line 1 (via front connector X1, connection 1) is correct. |
| C1 LED (flashing green) | An EU in the line is not ready for operation because <ul style="list-style-type: none"> • The power supply module is not switched on or • A module has not yet completed the initialization process |
| C2 LED (green) | Line 2 (via front connector X2, connection 2) is correct. |
| C2 LED (flashing green) | An EU in the line is not ready for operation because <ul style="list-style-type: none"> • The power supply module is not switched on or • A module has not yet completed the initialization process |

Operator Controls and Indicators of the Receive IM

| | |
|--------------------|--|
| INTF LED (red) | Lights up if a rack number > 21 or = 0 was set. Lights up if you have changed the rack number under voltage. |
| EXTF LED (red) | Lights up in the event of an external fault (line fault, for example, if the terminator is not inserted or if a module has not yet completed the initialization process, or if the CC is switched off) |
| DIP switch | DIP switch to set the number of the mounting rack. |
| Front connector X1 | Upper connector (input) for the connecting cable from the previous interface module. |
| Front connector X2 | Lower connector (output) for the connecting cable to the next interface module or for the terminator. |

Technical Specifications of the IM 460-4 and IM 461-4

| | |
|--|--|
| Maximum line length (total) | 605 m |
| Dimensions W x H x D (mm) | 25 x 290 x 280 |
| Weight <ul style="list-style-type: none"> • IM 460-4 • IM 461-4 | 630 g 620 g |
| Current consumption from the S7-400 bus 5 VDC <ul style="list-style-type: none"> • IM 460-4 • IM 461-4 | Typ. 1350 mA Max. 1550 mA Typ. 590 mA Max. 620 mA |
| Power loss <ul style="list-style-type: none"> • IM 460-4 • IM 461-4 | Typ. 6750 mW Max. 7750 mW Typ. 2950 mW Max. 3100 mW |
| Terminator | 6ES7461-4AA00-7AA0 |
| Backup current | No |

Compatibility

You cannot use the IM 460-4 and IM 461-4 interface modules with CPUs that have the following order numbers:

- 6ES7412-1XF00-0AB0
- 6ES7413-1XG00-0AB0
- 6ES7413-2XG00-0AB0
- 6ES7414-1XG00-0AB0
- 6ES7414-2XG00-0AB0
- 6ES7416-1XJ00-0AB0

IM 463-2

7

Chapter Overview

| Section | Description | Page |
|----------------|--|-------------|
| 7.1 | Using SIMATIC S5 Expansion Units in an S7-400 | 7-2 |
| 7.2 | Rules for Connecting S5 Expansion Units | 7-3 |
| 7.3 | Operator Controls and Indicators | 7-4 |
| 7.4 | Installing and Connecting the IM 463-2 | 7-6 |
| 7.5 | Setting the Operating Modes of the IM 314 | 7-8 |
| 7.6 | Configuring S5 Modules for Operation in the S7-400 | 7-10 |
| 7.7 | Pin Assignments of the 721 Connecting Cable | 7-11 |
| 7.8 | Terminating Connector for IM 314 | 7-13 |
| 7.9 | Technical Specifications | 7-14 |

Order Number

| | |
|-----------------|---------------------------|
| IM 463-2 | 6ES7463-2AA00-0AA0 |
|-----------------|---------------------------|

7.1 Using SIMATIC S5 Expansion Units in an S7-400

Area of Application

The IM 463-2 interface module is used for distributed connection of S5 expansion units to an S7-400.

You can use the IM 463-2 in the CR of the S7-400. In the S5 expansion unit, you use an IM 314.

This allows you to connect the following S5 expansion units to an S7-400:

- EU 183U
- EU 185U
- EU 186U
- ER 701-2
- ER 701-3

Accordingly, you can use all digital and analog I/O modules suitable for these EUs or ERs.

Basic Requirement

If you connect an S5 expansion unit to a CR of the S7-400 via an IM 463-2, the SIMATIC S5 basic requirements concerning EMC, ambient conditions, etc., apply for the overall system.

Note

In environments contaminated by radiated noise, you must apply the type 721 cable shield (see *Installation Manual*, Chapter 4).

Expanding the Distributed Connection

You can also centrally expand the EUs connected in a distributed configuration via an IM 463-2. The following table lists the S5 interface modules that you can use for this purpose.

Table 7-1 S5 Interface Modules

| Module | Order Number |
|--------|---|
| IM 300 | 6ES5300-5CA11 6ES5300-3AB11 6ES5300-5LB11 |
| IM 306 | 6ES5306-7LA11 |

7.2 Rules for Connecting S5 Expansion Units

Introduction

When you connect S5 expansion units to an S7-400 via the IM 463-2, there are rules to observe with regard to cable length, maximum expansion, use of a terminating connector and permissible potential differences.

Cable Length

The maximum cable length per IM 463-2 from the CR of the S7-400 to the last S5 expansion unit is 600 m. You set the actual cable length at the IM 463-2 (see Section 7.3).

Maximum Expansion

You can use up to four IM 463-2s in one S7-400 CR.

At each IM 463-2 interface (C1 and C2), you can connect up to four S5 expansion units in a distributed configuration.

You can connect further EUs centrally to the EUs connected in the distributed configuration.

Addressing of the S5 modules

All S5 address areas are available (P, Q, IM3, IM4)

Note

Note that every S5 address can only be used once, even **across different chains**.

Terminating Connector

You must terminate the IM 314 of the last EU in each chain with the 6ES5760-1AA11 terminating connector.

Permissible Potential Differences

For the safe functioning of the distributed configuration, you must ensure that the potential difference between two devices is not more than 7 V. Use an equipotential bonding conductor.

7.3 Operator Controls and Indicators

Introduction

All controls and indicators on the IM 463-2 are arranged on the front plate. The following figure shows the arrangement of the controls and indicators.

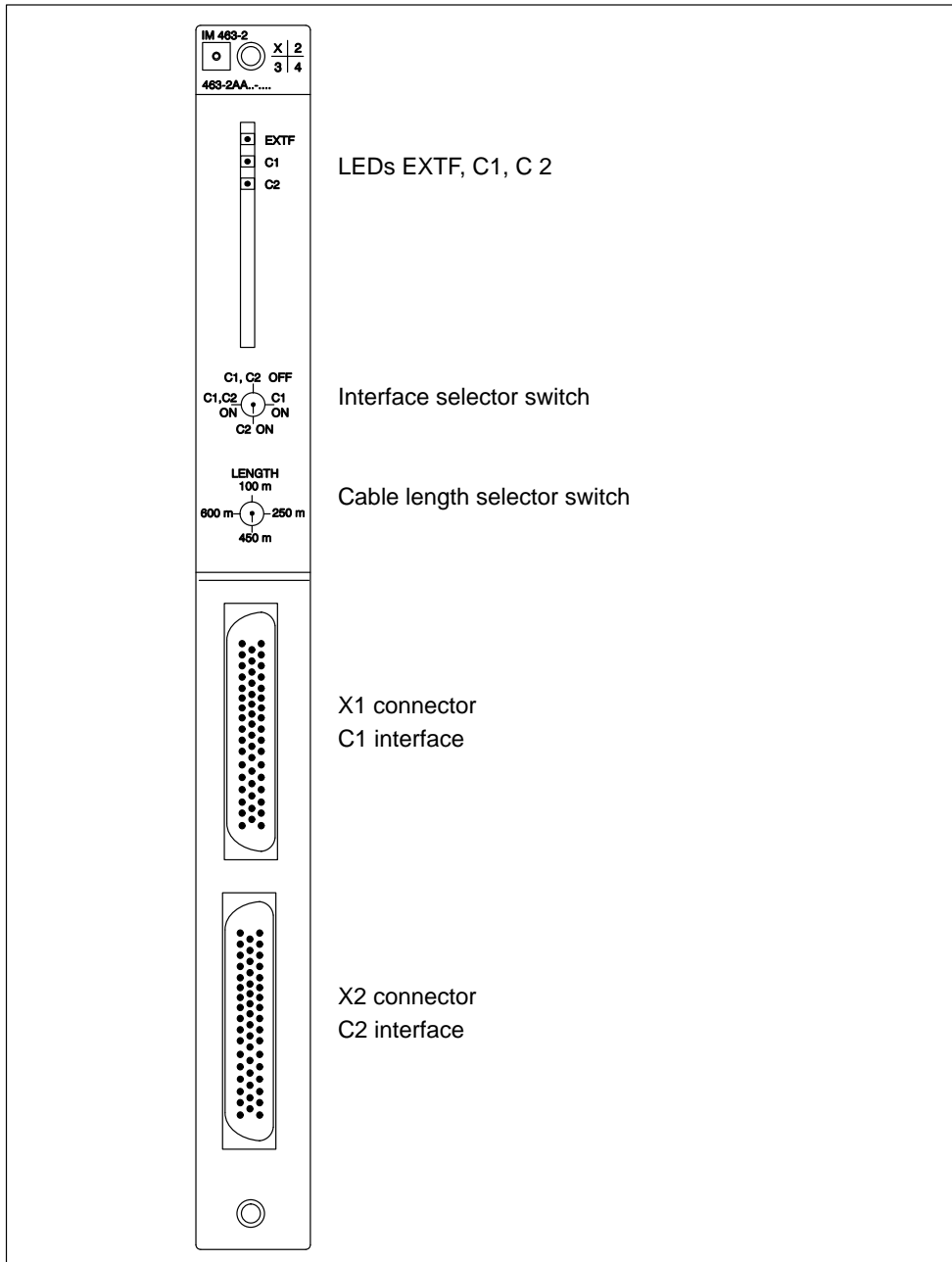

Figure 7-1 Layout of the Controls and Indicators of the IM 463-2

LEDs

Table 7-2 LEDs of the IM 4632

| LED | Meaning |
|---------------------------|---|
| LED EXTF (red) | Lights up in the event of an external fault. Chain 1 or chain 2 has a fault (power supply failed in the EU; terminating connector missing; wire break, or interface selector switch wrongly set). |
| LED C1 (green) | Chain 1 (via front connector X1, connection 1) is in order. |
| LED C2 (green) | Chain 2 (via front connector X2, connection 2) is in order. |
| Front connector X1 and X2 | Connector plug (output) for chain 1 and chain 2. X1 = upper front connector; X2 = lower front connector |

Interface Selector Switch

Table 7-3 LEDs of the IM 463-2

| Switch Position | Meaning |
|-----------------|---|
| C1 ON | You use only interface C1. |
| C2 ON | You use only interface C2. |
| C1, C2 ON | You use both interfaces. |
| C1, C2 OFF | You use neither of the two interfaces. You do not want to operate an S5 EU at present. |

Cable Length Selector Selector

Table 7-4 Switch Position: Interface Selector of the IM 463-2

| Switch Position | Meaning |
|-----------------|---------------------------|
| 100 | Cable length 1 to 100 m |
| 250 | Cable length 100 to 250 m |
| 450 | Cable length 250 to 450 m |
| 600 | Cable length 450 to 600 m |



Warning

Danger of data loss.

Changing the setting of the interface selector switch and the cable length selector switch in RUN mode can result in loss of data.

Change the settings of these switches only in STOP mode of the CPU.

7.4 Installing and Connecting the IM 463-2

Introduction

To install an IM 463-2 in a CR of the S7-400, proceed in the same way as when installing other S7-400 modules (see *Installation Manual*, Chapter 5).

To connect an IM 463-2, follow the steps outlined below:

1. Prepare the connecting cable
2. Plug in the connecting cable
3. Select the interface
4. Select the cable length

Preparing the Connecting Cable

You can use the 721 connecting cable. However, you must change the connector housing on the connection side of the IM 463-2.

Two connector housings are enclosed with every IM 463-2. You can prepare a connecting cable for an IM 463-2 using one of these connector housings and a 721 connecting cable (see *Catalog ST 54.1*). To prepare the connecting cable, follow the steps outlined below:

1. Remove one connector housing on the 721 connecting cable.
2. Open one of the connector housings enclosed with the IM 463-2.
3. Attach this connector housing to the 721 connecting cable.
4. Close the connector housing.

Plugging in the Connecting Cable

To plug in the connecting cable, follow the steps outlined below:

1. Open the cover of the IM 463-2.
2. Plug the new connector of the connecting cable into one of the connectors of the IM 463-2.

Interface C1 corresponds to the upper connector; interface C2 corresponds to the lower connector.

3. Screw the connector of the connecting cable onto the connector of the IM 463-2.
4. Close the cover.

Selecting the Interface

You select the interface with the selector switch on the front plate. Set the interface(s) here that you want to use. Make the settings on the IM 463-2 only when the CPU is in STOP mode.

Selecting the Cable Length

You select the cable length with the selector switch on the front plate. Set the range corresponding to the chain length. Make the settings on the IM 463-2 only when the CPU is in STOP mode.

7.5 Setting the Operating Modes of the IM 314

Introduction

To operate the IM 463-2, you must set on the IM 314 the S5 expansion unit used and the address area of the S5 I/O modules.

Setting the S5 Expansion Unit

You set the S5 expansion unit in which you want to use the IM 314 using jumpers BR1, BR2, and BR3 on the IM 314.

The following figure shows where these jumpers are located on the IM 314 and which setting corresponds to which expansion unit.

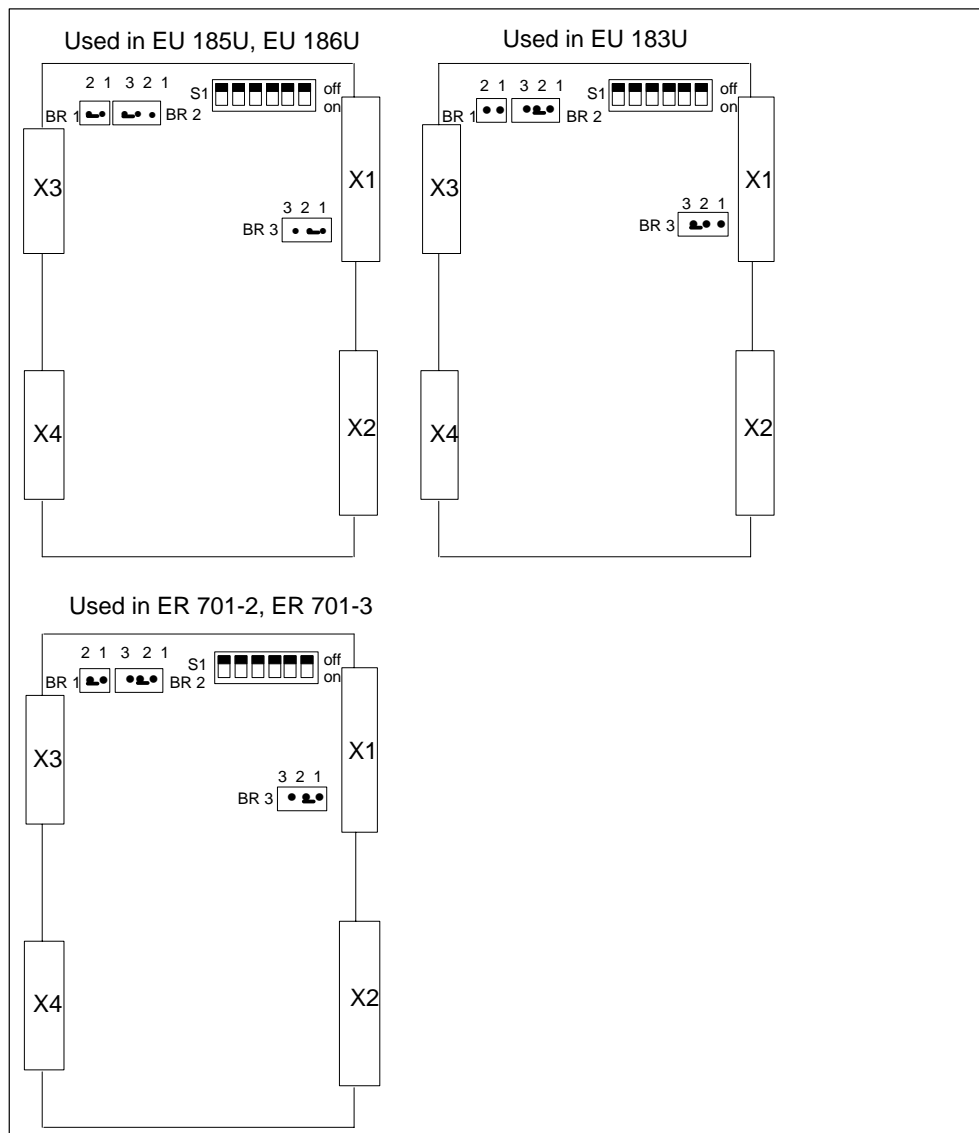



Figure 7-2 Settings of the IM 314 with Expansion Units

Setting the Address Area

The address area of the S5 I/O modules is set on the IM 314. This setting applies only for the digital and analog I/O modules.

The address areas P, Q, IM3, and IM4 are available. Set the switch to the relevant position to address the digital and analog I/O modules in these areas.

Table 7-5 Settings Address Areas on the IM 314

| I/O Area Address | Switch Position | |
|-----------------------|-----------------|---|
| | 0 = OFF, | 1 = ON |
| P area: F000 - F0FF | S1: 0000 *) |  |
| Q area: F100 - F1FF | 0001 | |
| IM3 area: FC00 - FCFF | 1100 | |
| IM4 area: FD00 - FDFF | 1101 | |

*) Status as shipped

7.6 Configuring S5 Modules for Operation in the S7-400

You configure the S5 modules using STEP 7. See the description of STEP 7 or the online help function for details of how to proceed.

The following figure shows a possible connection of CRs and EUs via the IM 463-2 and IM 314.

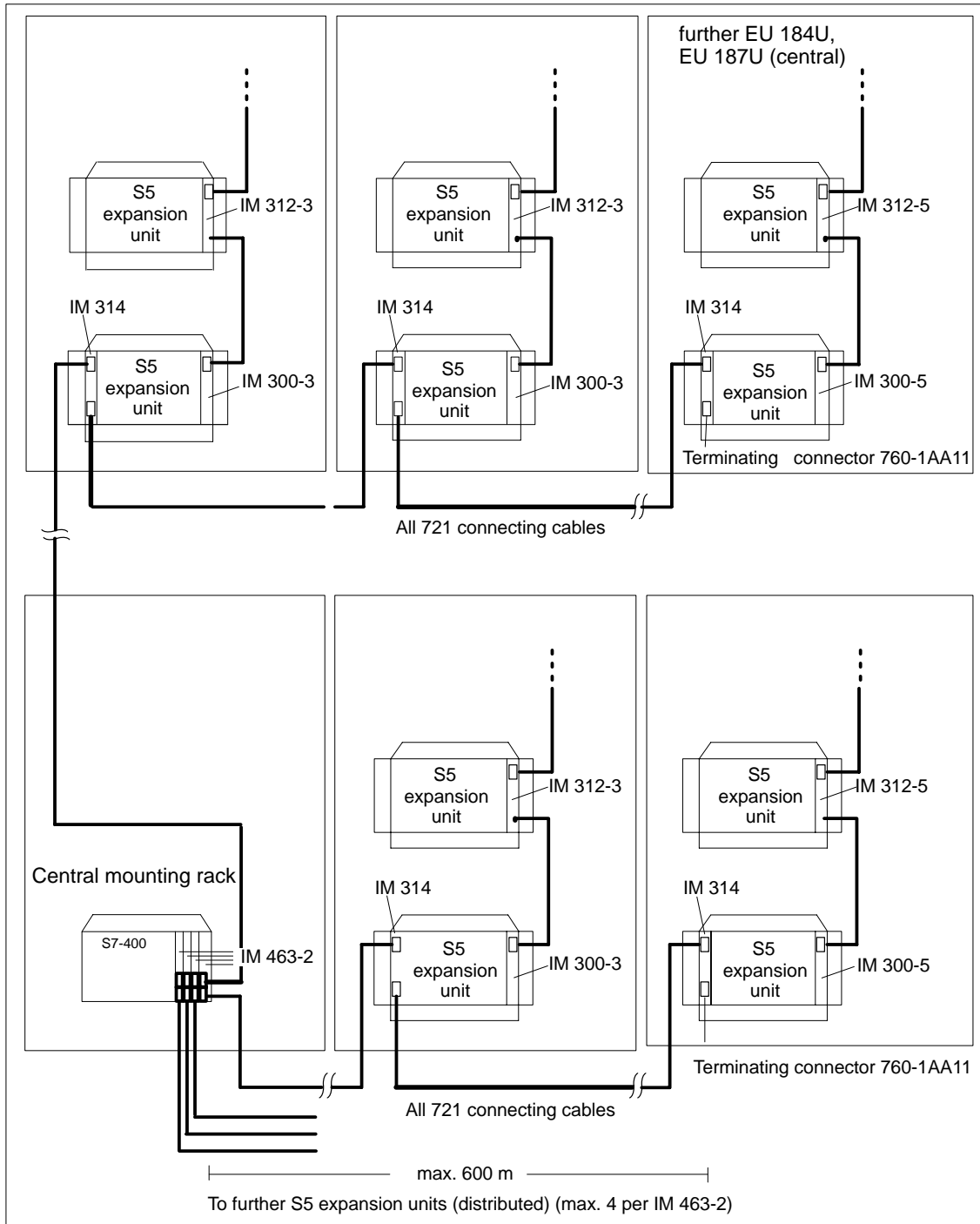
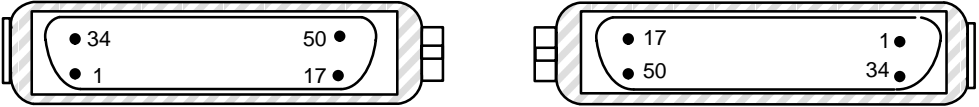

Figure 7-3 Connection Variant for CCs and EUs via the IM 463-2 and IM 314

7.7 Pin Assignments of the 721 Connecting Cable

Table 7-6 Assignment of the Connecting Cable 721



| Connector 50-Pin Contact | Bundle Ident. Sheath | Identification Foil | Core Color | Connector 50-Pin Contact |
|--------------------------|----------------------|---------------------|------------|--------------------------|
| 20 | 1 No. 16 | red | white | 20 |
| 21 | | | brown | 21 |
| 4 | | | green | 4 |
| 5 | | | yellow | 5 |
| 18 | | | gray | 18 |
| 19 | | | pink | 19 |
| 2 | | | blue | 2 |
| 3 | | | red | 3 |
| 24 | 2 No. 17 | green | white | 24 |
| 25 | | | brown | 25 |
| 8 | | | green | 8 |
| 9 | | | yellow | 9 |
| 22 | | | gray | 22 |
| 23 | | | pink | 23 |
| 6 | | | blue | 6 |
| 7 | | | red | 7 |
| 26 | 3 No. 18 | yellow | white | 26 |
| 27 | | | brown | 27 |
| 10 | | | green | 10 |
| 11 | | | yellow | 11 |
| 42 | | | gray | 42 |
| 43 | | | pink | 43 |
| 44 | | | blue | 44 |
| 45 | | | red | 45 |

Table 7-6 Assignment of the Connecting Cable 721, continued

| Connector 50-Pin Contact | Bundle Ident. Sheath | Identification Foil | Core Color | Connector 50-Pin Contact |
|-----------------------------|-------------------------|---------------------|------------|-----------------------------|
| 28 | 4 No. 19 | brown | white | 28 |
| 29 | | | brown | 29 |
| 12 | | | green | 12 |
| 13 | | | yellow | 13 |
| 46 | | | gray | 46 |
| 47 | | | pink | 47 |
| 30 | | | blue | 30 |
| 31 | | | red | 31 |
| 34 | 5 No. 20 | black | white | 34 |
| 35 | | | brown | 35 |
| 36 | | | green | 36 |
| 37 | | | yellow | 37 |
| 38 | | | gray | 38 |
| 39 | | | pink | 39 |
| 40 | | | blue | 40 |
| 41 | | | red | 41 |
| 48 | 6 No. 21 | blue | white | 48 |
| 49 | | | brown | 49 |
| 14 | | | green | 14 |
| 15 | | | yellow | 15 |
| 32 | | | gray | 32 |
| 33 | | | pink | 33 |
| - | Shield | | | - |

7.8 Terminating Connector for IM 314

Introduction

The IM 314 of the last expansion unit of each chain is terminated with the 6ES5 760-1AA11 terminating connector.

Table 7-7 Assignment of the Terminator 760-1AA11

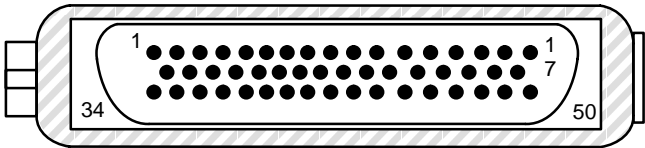
|  | | | |
|--|------------------------------|--|-----------------|
| Plug Connection | 180-Ohm Resistance or Jumper | | Plug Connection |
| 28 | | | 8 |
| 29 | | | 9 |
| 26 | | | 6 |
| 27 | | | 7 |
| 48 | | | 4 |
| 47 | | | 5 |
| 44 | | | 2 |
| 45 | | | 3 |
| 42 | | | 24 |
| 43 | | | 25 |
| 38 | 1) | | 22 |
| 39 | | | 23 |
| 34 | 1) | | 20 |
| 35 | | | 21 |
| 36 | 1) | | 18 |
| 37 | | | 19 |
| 40 | 1) | | 12 |
| 41 | | | 13 |
| 48 | 2) | | 10 |
| 49 | | | 11 |
| 15 | | | 30 |
| 16 | | | 31 |
| 14 | | | |
| 50 | | | |
| 1) 100 Ω | | | |
| 2) 200 Ω | | | |

7.9 Technical Specifications (6ES7463-2AA00-0AA0)

| Programming package | | Voltages, Currents, Potentials | |
|--|---|---------------------------------------|---------------------------|
| Associated programming package | As of STEP7 V 2.1 | Supply voltage from S7-400 bus | +5 V |
| Dimensions and Weight | | Current consumption | typ. 1.2 A max. 1.32 A |
| Dimensions WxHxD (mm) | 25x290x280 | Power losses | typ. 6 W max. 6.6 W |
| Weight | 360 g | | |
| Module-Specific Data | | | |
| Number and type of interfaces | 2 parallel, symmetrical interfaces | | |
| Cable length: from IM 463-2 to the last IM 314 (per interface) | max. 600 m | | |
| Transmission rate | 2 Mbytes/s to 100 Kbytes/s | | |
| Parameter sets of the signal modules | differential signal in accordance with RS 485 | | |
| Front connector | 2 connectors, 50-pin male | | |

PROFIBUS DP Master Interface IM 467/IM 467 FO

8

Chapter Overview

| Section | Description | Page |
|---------|---|------|
| 8.1 | PROFIBUS DP Master Interface IM 467/IM 467 FO | 8-2 |
| 8.2 | Configuration | 8-6 |
| 8.3 | Connection to PROFIBUS DP | 8-8 |
| 8.4 | Technical Specifications | 8-12 |

8.1 PROFIBUS DP Master Interface IM 467/IM 467 FO

Order Numbers

| | |
|-----------|-----------------------------|
| IM 467 | 6ES7467-5GJ02-0AB0 (RS 485) |
| IM 467 FO | 6ES7467-5FJ00-0AB0 (FO) |

Application

PROFIBUS DP, standardized to IEC 61784–1:2002 Ed1 CP 3/1, enables rapid communication in the field between programmable controllers, PCs and field devices. Field devices are devices such as: ET 200 distributed I/O devices, drives, valve terminals, switchgear and many others.

The IM 467/IM 467 FO interface module is meant to be used in an S7-400 programmable controller. It permits the S7-400 to be connected to PROFIBUS DP.

Note

The PROFIBUS DP master interface IM 467 or IM 467 FO is not a DP master in accordance with DPV 1.

Configuration

- Configured as for the S7-400
- Can be operated without a fan
- A maximum of 4 IM 467/IM 467 FO can be used in the central controller. There are no slot rules.
- The IM 467/IM 467 FO and the CP 443-5 Extended cannot be used together.
- The transmission rate of 9.6 kbps to 12 Mbps can be set in steps using software
- Configuration and programming are possible via PROFIBUS DP. You must **not**, however, change the PROFIBUS DP parameters.
- IM 467 with 9-pin subminiature D female connector for connection to PROFIBUS DP (6ES7467-5GJ02-0AB0)
- IM 467 FO with fiber-optic cable for connection to PROFIBUS DP (6ES7467-5FJ00-0AB0)

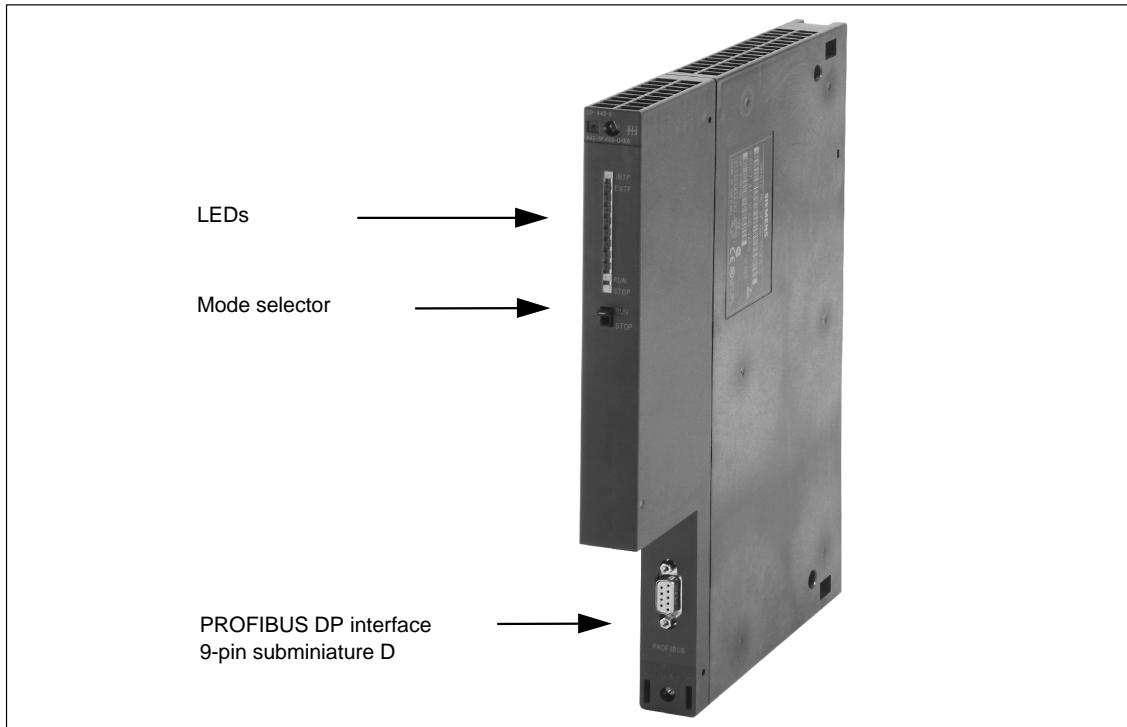

Figure 8-1 Configuration of the IM 467/467 FO

Communication Services

The IM 467/IM 467 FO offers two communication services:

- PROFIBUS DP

The IM 467/IM 467 FO is a PROFIBUS DP master in accordance with EN 50 170. It is configured entirely with STEP 7. It behaves in basically the same way as the integrated PROFIBUS DP interfaces on the CPU modules (see the technical specifications of the IM 467/IM 467 FO for the differences).

DP communication does not require any function calls in the STEP 7 user program.

- S7 functions

The S7 functions guarantee optimal and easy communication in a SIMATIC S7/M7/C7 automation solution. The following S7 functions are enabled for the IM 467/IM 467 FO:

- Programming device functions via PROFIBUS DP
- Operator control and monitoring functions via PROFIBUS DP

Communication takes place without any additional configuration on the IM 467/IM 467 FO.

S7 functions can be used on their own or in parallel with the PROFIBUS DP protocol. If they are used in parallel with DP communication, this affects the PROFIBUS DP bus cycle time.

8.1.1 Indicators and the Mode Selector

LED

The LED plate on the front panel of the IM 467/IM 467 FO has the following four indicators:

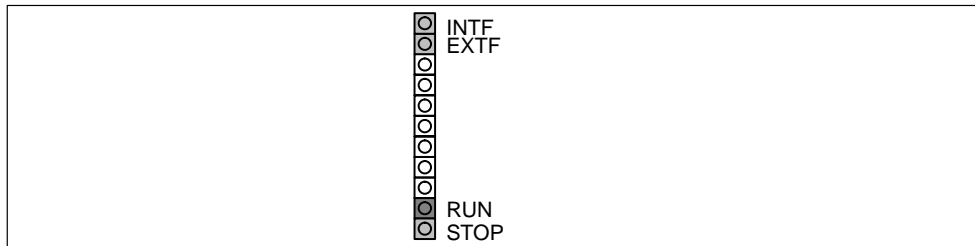

Figure 8-2 LEDs of the IM 467/467 FO

IM Operating Mode

The LEDs indicate the operating mode of the IM in accordance with the following table:

Table 8-1 Operating Modes of the IM 467/467 FO

| STOP LED (yellow) | RUN LED (green) | EXTf LED (red) | INTf LED (red) | CP Operating Mode |
|----------------------|--------------------|-------------------|-------------------|---|
| On | Flashing | Off | Off | Startup |
| Off | On | Off | Off | RUN |
| Flashing | On | Off | Off | STOPPING |
| On | Off | Off | Off | STOP |
| On | Off | Off | On | STOP with internal error (IM not configured, for example) |
| Flashing | Off | Off | Off | Waiting for FW update (takes 10 sec. after power up) |
| Flashing | Off | On | On | Waiting for FW update (IM currently contains an incomplete FW version). |
| Off | On | On | Off | RUN and PROFIBUS DP bus fault |
| Off | On | Flashing | Off | RUN; but there are faults on the DP line (the DP slave is not taking part in data transfer, or the module in the DP slave is faulty, for example) |
| Flashing | Flashing | Flashing | Flashing | Module error/ System error |

Controlling the Operating Mode

There are two ways to control the operating mode of the IM 467/IM 467 FO:

- By using the mode selector
- By using the programming device/PC

Mode Selector

You can switch operating modes as follows using the mode selector:

- From STOP to RUN

All the configured communication services and S7 communication services are available in RUN.

The IM operating mode can only be controlled from the programming device/PC when the switch is in the RUN position.

- From RUN to STOP

The IM goes into STOP mode. Any existing S7 connections are cleared down, and the DP slaves are no longer supplied.

Loadable Firmware

The IM 467/IM 467 FO supports the updating of firmware (FW) by means of the FW loader. The FW loader is a component of the NCM S7 configuration software for PROFIBUS DP. Authorization is not required for this. After a FW update, the central controller must be switched off and on again before normal operation can be resumed.

Note

You can find additional information on loading firmware in the NCM S7 for PROFIBUS DP manual and in the readme file of the NCM S7 for PROFIBUS DP configuration software.

Note

An optical bus terminal (OBT) is required to load FW in the IM 467 FO.

8.2 Configuration

The IM 467/IM 467 FO is configured with STEP 7. The configuration data are retained even in the event of a power failure; a memory module is not required. Using the S7 functions it is possible to program and configure remotely all the IM 467/IM 467 FO connected to the network and all the CPUs connected via the SIMATIC S7-400 backplane bus.

SIMATIC STEP 7 is the prerequisite for this.

- STEP 7 V3.1

The IM 467 (MLFB no. 6ES7467-5GJ00-0AB0) can be configured as of STEP 7 version 3.1.

- STEP 7 V4.02

The IM 467 (MLFB no. 6ES7467-5GJ01-0AB0) supports the SYNC/FREEZE functional enhancement as of STEP 7 version 4.02.

- STEP 7 as of version 5.00

The IM 467/IM 467 FO (MLFB number 6ES7467-5GJ02-0AB0/6ES7467-5FJ00-0AB0) supports the functional expansions of routing of programming device functions, DP direct communication and equidistance as of STEP 7 version 5.00.

Module Replacement Without a Programming Device

The configuration data are stored in the load memory of the CPU. The non-volatile storage of configuration data in the CPU is ensured by battery backup or EPROM module cards.

The IM 467/IM 467 FO can be replaced without the need to explicitly reload the configuration data.

It is only possible to remove and insert the IM 467/IM 467 FO in a deenergized state.

Multiprocessor Operation

The connected DP slaves can only be assigned to and processed by one CPU.

Configuration and Diagnostics Cannot Be Carried Out Simultaneously

When configuration is in progress, the IM 467/IM 467 FO cannot be diagnosed at the same time via MPI.

Prerequisites

The IM 467/IM 467 FO is supported by all the CPU operating systems beginning with the release numbers listed below.

You will also find the following information in the table:

- The number of IM 467/IM 467 FO that can be operated on a CPU
- Support of multiprocessor operation

Table 8-2 CPU and IM 467/467 FO

| CPU | MLFB Number | Release | Multiprocessor Operation Possible | No. of IM 467 Possible |
|-------|--------------------|---------|-----------------------------------|------------------------|
| 412 | 6ES7412-1XF03-0AB0 | 1 | Yes | 4 |
| 412-2 | 6ES7412-2XG00-0AB0 | 1 | Yes | 4 |
| 414-2 | 6ES7414-2XG03-0AB0 | 1 | Yes | 4 |
| 416-2 | 6ES7416-2XK02-0AB0 | 1 | Yes | 4 |
| 416-3 | 6ES7414-3XL00-0AB0 | 1 | Yes | 4 |
| 417-4 | 6ES7417-4XL00-0AB0 | 1 | Yes | 4 |

Note

The 3 MB and 6 MB transmission rates are not enabled for the IM 467-FO.

8.3 Connection to PROFIBUS DP

There are two ways of connecting to PROFIBUS DP:

- Electrical connection via a bus connector
- Optical connection using a fiber-optic cable

8.3.1 Bus Connector

Only with 6ES7467-5GJ02-0AB0.

The bus cable is connected to the IM 467 by means of this connector. (See the detailed description in the chapter on networking in the S7-400/M7-400, Hardware and Installation manual.)

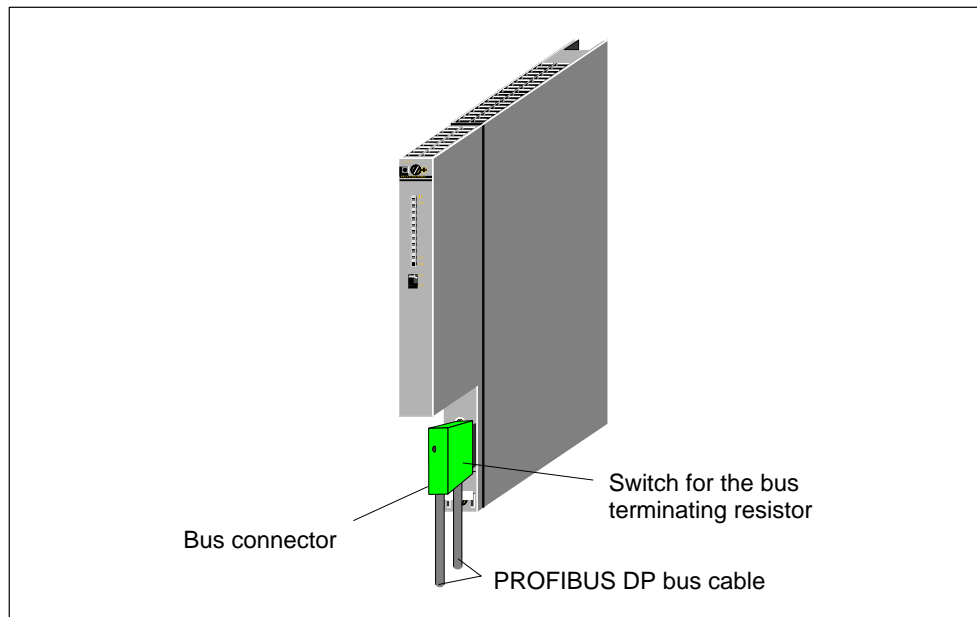

Figure 8-3 Connecting the Bus Connector to the IM 467

Maximum Cable Lengths for PROFIBUS DP

| | | | | | | | | | |
|--|--------|--------|--------|--------|-------|-------|-------|--------|-------|
| Transmission Rate in Kbps | 9.6 | 19.2 | 93.75 | 187.5 | 500 | 1500 | 3000 | 6000 W | 12000 |
| Max. Length of a Bus Segment in m | 1.000 | 1.000 | 1.000 | 1.000 | 400 | 200 | 100 | 100 | 100 |
| Max. Number of Bus Segments 1) | 10 | 10 | 10 | 10 | 10 | 10 | 10 | 10 | 10 |
| Max. Length in m | 10.000 | 10.000 | 10.000 | 10.000 | 4.000 | 2.000 | 1.000 | 1.000 | 1.000 |

¹⁾ Bus segments are interconnected by means of RS 485 repeaters

Connector Pin Assignment

The electrical interface used to connect to PROFIBUS DP (9-pin subminiature D female connector) is specified in the following table.

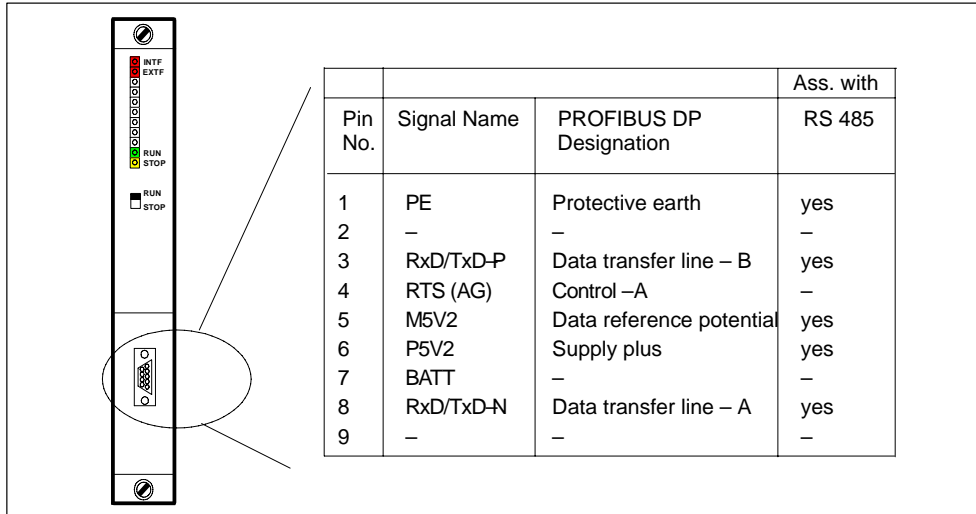

Figure 8-4 Connector Pin Assignment

8.3.2 Optical Connection to PROFIBUS DP

Only in the case of 6ES7467-5FJ00-0AB0.

The IM 467 FO with an integrated fiber-optic cable interface is available for connecting to the optical version of PROFIBUS DP.

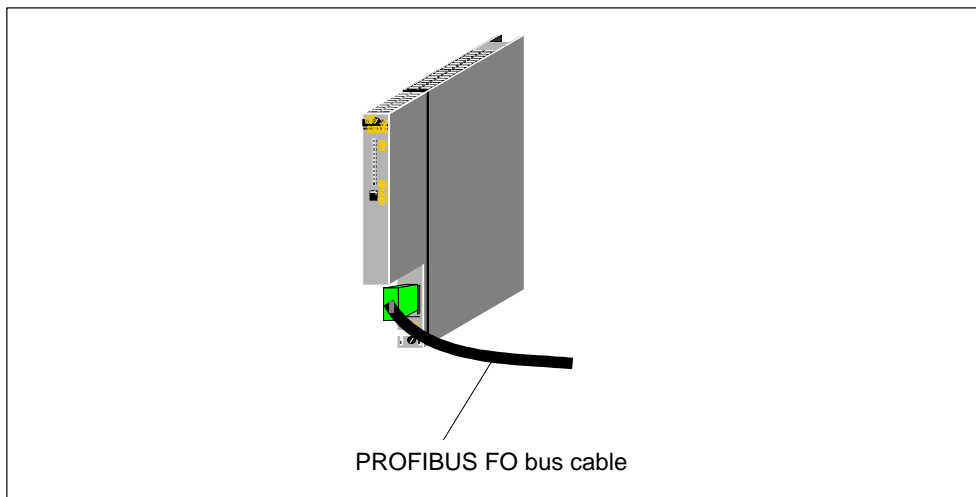

Figure 8-5 Optical Connection to PROFIBUS DP

8.3.3 Connecting a Fiber-Optic Cable to the IM 467 FO

Accessories Required

- Pack of Simplex connectors and polishing sets (6GK1901-0FB00-0AA0)
- Pack of plug-in adapters (6ES7195-1BE00-0XA0)

Installing Connectors

1. Remove approximately 30 cm of the sheath of the fiber-optic duplex cable.
2. Install the fiber-optic duplex cable with the associated Simplex connectors. You can find a detailed description of Simplex connectors in the "SIMATIC NET PROFIBUS Networks" manual.

TIP: Close the two Simplex connectors together rather than separately to obtain a Duplex connector. This ensures a more secure position in the plug-in adapter.

IMPORTANT: The polished surface of the plastic fibers must be absolutely smooth and even. The plastic sheath must not stick out or be cut unevenly. If this is not the case, considerable attenuation of the light signal via the fiber-optic cable may occur.

3. Place the Simplex connectors in the plug-in adapter for the IM 467 FO and the fiber-optic cable in the cable guides provided. Insert the plug-in adapter until you hear the sides clearly latch into position.

Make sure when you insert the plugs in the plug-in adapter that the sender is always at the top and the receiver is underneath.

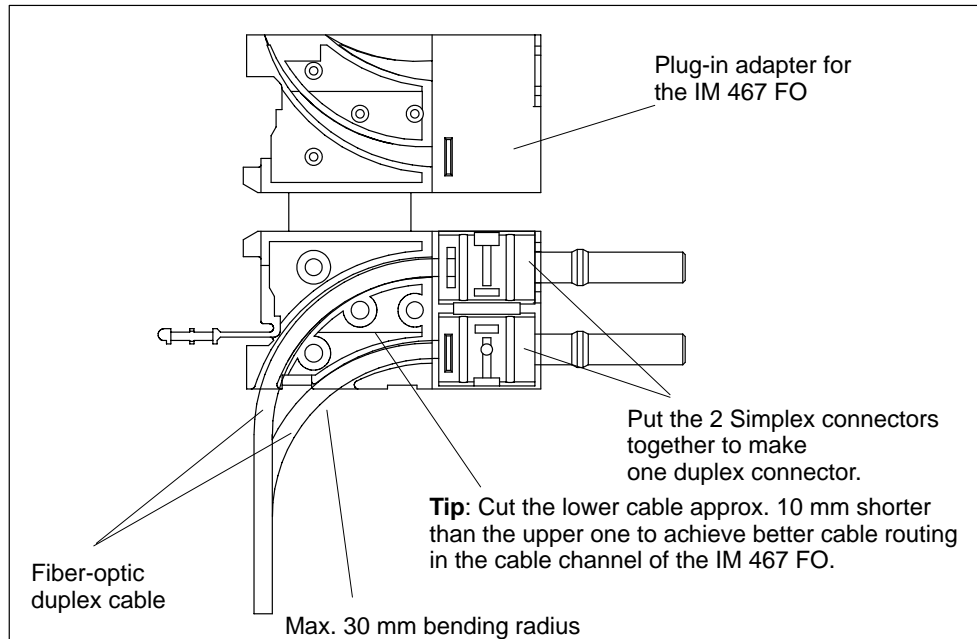

Figure 8-6 Installing the Connector

Reusing Fiber-Optic Cables

Note

If you insert used fiber-optic cables in the plug-in adapter again, you must cut off the bent lengths of both fiber-optic cable cores and install the Simplex connectors again.

This avoids any attenuation losses due to parts of the cores of the fiber-optic duplex cables being bent again and overstressed.

Inserting the Fiber-Optic Cables into the IM 467 FO

Insert the fiber-optic cables and attached plug-in adapters into the IM 467 FO. Move the protruding handle of the plug-in adapter upwards.

Make sure that it is correctly positioned: The sender fiber-optic cable is plugged into the receiver socket, and the receiver fiber-optic cable is inserted into the sender socket of the fiber-optic interface of the IM 467 FO.

If the IM 467 FO is the last node in the fiber-optic network, you must close the unoccupied fiber-optic cable interface with filler connectors (the connectors are already in place when the IM 467 FO is delivered).



Caution

Do not look directly into the opening of the optical sender diodes. The light beam could damage your eyes.

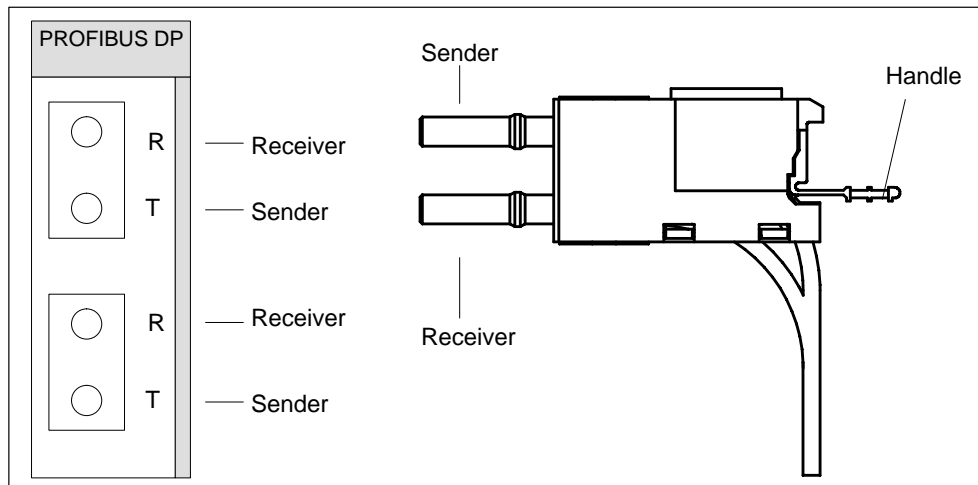

Figure 8-7 Inserting the Fiber-Optic Cables into the IM 467 FO

Bending Radius for the Fiber-Optic Cable

Make sure when you wire the fiber-optic duplex cable cores and insert them into the plug-in adapter that the permissible bending radius of 30 mm is not violated. See also the installation guidelines on fiber-optic cables in the SIMATIC NET PROFIBUS Networks manual.

8.4 Technical Specifications

8.4.1 Technical Specifications of the IM 467

6ES7467-5GJ02-0AB0.

| Dimensions and Weight | |
|--|--|
| Dimensions W x H x D (mm) | 25 x 290 x 210 |
| Weight | 700 g |
| PROFIBUS DP | |
| <ul style="list-style-type: none"> Standard | PROFIBUS DP, EN 50 170 |
| <ul style="list-style-type: none"> Transmission rate | 9.6 kbps to 12 Mbps, parameterizable in steps |
| <ul style="list-style-type: none"> Transmission technology | RS 485 via 9-pin subminiature D female connector |
| Current consumption | |
| Current consumption from the S7-400 bus (24 VDC) The IM does not consume any current at 24 V, and it only makes this voltage available at the MPI/DP interface. | Total current consumption of the components connected to the DP interfaces, with a maximum of 150 mA |

| PROFIBUS DP | |
|--|---|
| Conditions of Use | |
| Can be used in | SIMATIC S7-400, max. 4 IM 467 in the central controller |
| IM 467 cannot be used together with the CP 443-5 | |
| Supply voltage | 5 VDC via the backplane bus |
| Current consumption | 1.3 A |
| <ul style="list-style-type: none"> From 5 VDC | |
| Addressing range | Max. 4 KB for inputs and 4 KB for outputs |
| DP master | Yes |
| <ul style="list-style-type: none"> DPV 1 | No |
| <ul style="list-style-type: none"> Enable/disable | No |
| Number of connectable I/O devices (slaves) | 96 |
| Number of connections for S7 functions for the programming device and operation and monitoring | 32 + 1 diagnostic connection |
| Data volume per slave | Max. 244 bytes |
| Consistency | Max. 128 bytes |
| Configuration software | STEP 7 |
| DP slave | No |
| Deviations from the DP Interface Integrated in the CPU | |
| <ul style="list-style-type: none"> Different SSL IDs for system diagnostics Possibly extended SFC run times Additional return codes for SFC 14 and SFC 15 | |

8.4.2 Technical Specifications of the IM 467 FO

6ES7 467-5FJ00-0AB0

| Dimensions and Weight | |
|--|--|
| Dimensions W x H x D (mm) | 25 x 290 x 210 |
| Weight | 700 g |
| PROFIBUS DP | |
| <ul style="list-style-type: none"> Standard | PROFIBUS DP, EN 50 170 |
| <ul style="list-style-type: none"> Transmission rate | 9.6 kbps to 12 Mbps, parameterizable in steps (3 Mbps and 6 Mbps not possible) |
| <ul style="list-style-type: none"> Transmission technology | FOC Wavelength $\lambda = 660 \text{ nm}$ 2 x Duplex socket |
| Current consumption | |
| Current consumption from the S7-400 bus (24 VDC) The IM does not consume any current at 24 V, and it only makes this voltage available at the MPI/DP interface. | Total current consumption of the components connected to the DP interfaces, with a maximum of 150 mA |

| PROFIBUS DP | |
|--|---|
| Conditions of Use | |
| Can be used in | SIMATIC S7-400, max. 4 IM 467 in the central controller |
| IM 467 cannot be used with the CP 443-5 | |
| Supply voltage | 5 VDC via the backplane bus |
| Current consumption | 1.3 A |
| <ul style="list-style-type: none"> From 5 VDC | |
| Addressing range | Max. 4 KB for inputs and 4 KB for outputs |
| DP master | Yes |
| <ul style="list-style-type: none"> DPV 1 | No |
| <ul style="list-style-type: none"> Enable/disable | No |
| Number of connectable I/O devices (slaves) | 96 |
| Number of connections for S7 functions for the programming device and operator control and monitoring | 32 + 1 diagnostic connection |
| Data volume per slave | Max. 244 bytes |
| Consistency | Max. 128 bytes |
| Configuration software | STEP 7 |
| DP slave | No |
| Deviations from the DP Interface Integrated in the CPU | |
| <ul style="list-style-type: none"> Different SSL IDs for system diagnostics Possibly extended SFC run times Additional return codes for SFC 14 and SFC 15 | |

9

Cable Duct and Fan Subassemblies

Chapter Overview

| Section | Description | Page |
|---------|---|------|
| 9.1 | Fan Monitoring in the Fan Subassemblies | 9-2 |
| 9.2 | Cable Duct; (6ES7408-0TA00-0AA0) | 9-4 |
| 9.3 | The 120/230 VAC Fan Subassembly; (6ES7408-1TB00-0XA0) | 9-5 |
| 9.4 | The 24 VDC Fan Subassembly; (6ES7408-1TA00-0XA0) | 9-7 |

Characteristics

The cable duct and the fan subassembly have the following characteristics

- The air inflow area is variable.
- Shield and cable clamping are possible.

In addition, the fan subassembly has the following characteristics:

- Fans and filter frames can be replaced from the front during operation.
- The fan function is controlled by means of speed monitoring.
- Operation with filter frames is optional.

9.1 Fan Monitoring in the Fan Subassemblies

In this section, you will find out how to monitor the fans.
There is a signaling concept example at the end of the section.

LEDs

The three red LEDs are assigned to the individual fans. From left to right, these are:

- F1 – for fan 1
- F2 – for fan 2
- F3 – for fan 3

Fans

The fans have a redundant design. The fan subassembly continues to function even if one fan fails.

Fan Monitoring

The function of the fans is controlled by means of speed monitoring. If the speed of a fan drops below the limit speed of 1750 rpm, the LED assigned to it lights up. In addition, the relay K1 drops out.

If the speed of a second fan drops below the limit speed, the LED assigned to it lights up; in addition, the relay K2 drops out.

The following table is the function table for the fan monitoring.

Table 9-1 Function of Fan Monitoring

| Fan1 | Fan2 | Fan3 | LED F1 | LED F2 | LED F3 | Relay K1 | Relay K2 |
|------|------|------|--------|--------|--------|----------|----------|
| – | – | – | L | L | L | – | – |
| – | – | + | L | L | D | – | – |
| – | + | – | L | D | L | – | – |
| + | – | – | D | L | L | – | – |
| – | + | + | L | D | D | – | + |
| + | – | + | D | L | D | – | + |
| + | + | – | D | D | L | – | + |
| + | + | + | D | D | D | + | + |
| –* | –* | –* | D* | D* | D* | –* | –* |

- + Fan in operation or relay picked up
- Fan failed or relay dropped out
- D LEDs dark
- L LEDs lit
- * Power off

Signaling Concept Example

You can check the fault-free functioning of the fan subassembly using digital inputs.

You can cause the power supply to be cut off after the failure of at least two fans by using the relay K2. For example, you can use an intermediate contactor to interrupt the mains.

The relay contacts are labeled as follows:

Relay K1: No. 1...3

Relay K2: No. 4...6

The following diagram explains the circuit in the fan subassembly when all fans are functioning.

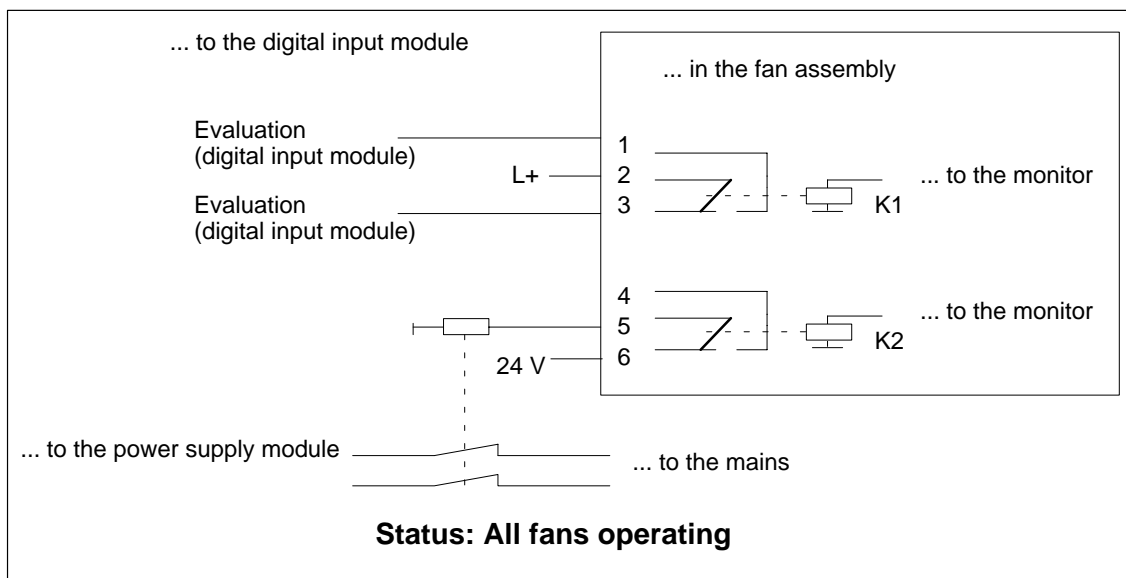

Figure 9-1 Example of a Message Concept

9.2 Cable Duct; (6ES7408-0TA00-0AA0)

Function

The cable duct is used in installations outside the cabinet for

- Cable clamping and/or for
- Shielding or for
- Air circulation without fan assistance

Front View of the Cable Duct

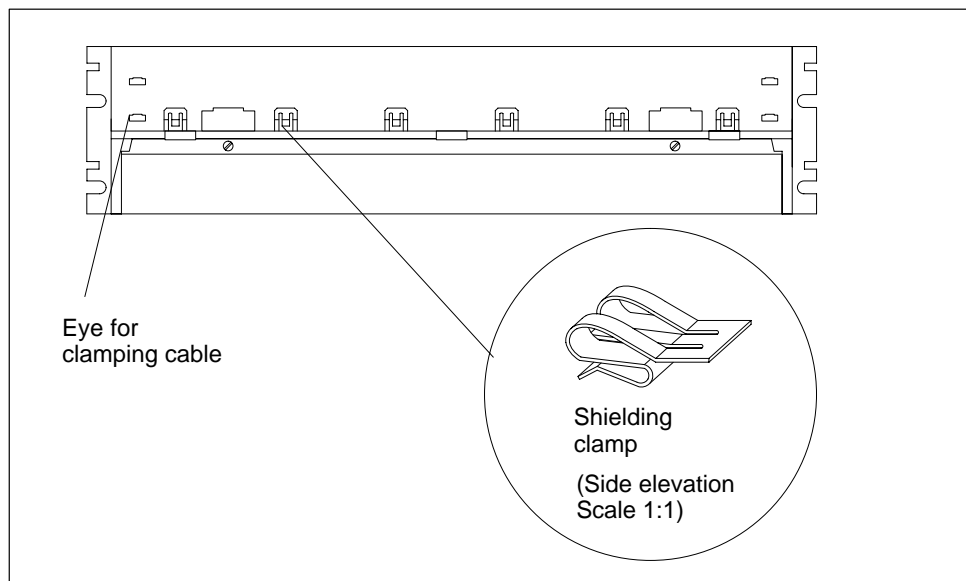

Figure 9-2 Front View of the Cable Channel

Shielding Clamps

If you do not require the shielding clamps supplied, do not install them in the cable duct.

Technical Specifications

| | |
|---------------------------|---------------------|
| Dimensions W × H × D (mm) | 482.5 × 109.5 × 235 |
| Weight | ca. 1200 g |

9.3 The 120/230 VAC Fan Subassembly; (6ES7408-1TB00-0XA0)

Operator Controls and Indicators on the 120/230 VAC Fan Subassembly

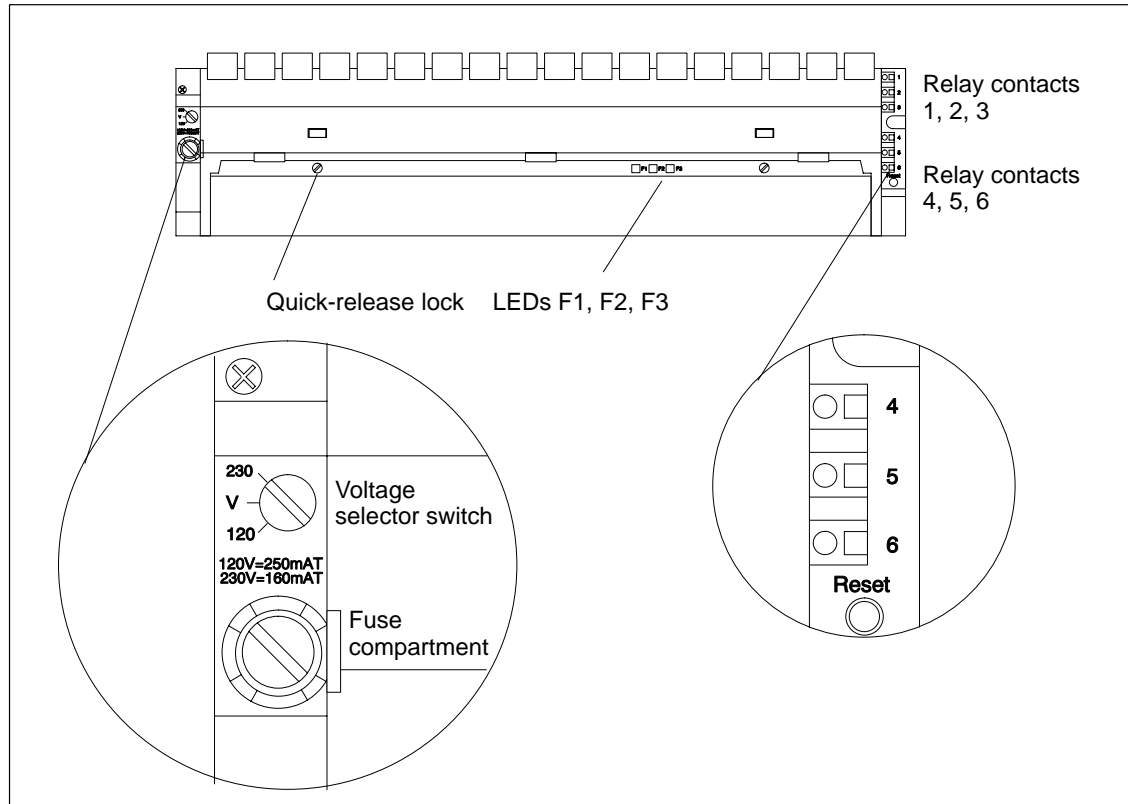

Figure 9-3 Controls and Indicators of the Fan Subassembly 120/230 VAC (6ES7408-1TB00-0XA0)

Fuse

Included in this fan subassembly are standard cartridge fuse links, 5 x 20 mm, conforming to DIN

- 250 mAT for 120 V
- 160 mAT for 230 V.

The fuse for the 230 V range is already installed on shipping from the factory.

Note

If you change the voltage range, you must also insert the fuse for this voltage range in the fan subassembly. You will find a description of how to change the fuse in the *Installation Manual*, Chapter 9.

Shielding Clamps

If you do not require the shielding clamps supplied, do not install them in the fan subassembly.

Technical Specifications

| Dimensions, Weights | | Voltages, Currents, Potentials | |
|--|-----------------|--------------------------------|-----------------|
| Dimensions WxHxD (mm) | 482.5×109.5×235 | At nominal voltage of | 230 VAC 120 VAC |
| Weight | appr. 2000 g | Power consumption | |
| Cable diameter | 3 bis 9 mm | • with fan | 17 W 18 W |
| Nominal Sizes | | • without fan | 5 W 4 W |
| Lifespan of the fans | | Starting current | 0,6 A 1,15 A |
| • at 40 °C | 70000 h | Fuses | 160 mA 250 mA |
| • at 75 °C | 25000 h | | |
| Max. contact load of relay contacts 1 to 6 | | | |
| • Switching voltage | 24 VDC | | |
| • Switching current | 200 mA | | |



Warning

Electrical current can lead to personal injury.

If you remove the left cover when installing or removing the fan subassembly, the terminals on the transformer are accessible briefly.

Remove the voltage from the fan subassembly before you install or remove it. Disconnect the supply cable before you remove the fan subassembly.



Caution

Danger of damage to equipment.

If you mix up the power supply PCB and the monitoring PCB in the fan subassembly, the fan subassembly may be damaged.

During maintenance of the unit, make sure you do not mix up the power supply PCB and the monitoring PCB.

Monitoring Function

In the case of a fault (defective fans) the fans are not switched off. Once you have replaced the defective fan(s), the fault is acknowledged automatically as soon as the fans have reached the required speed. Any faults that occur are not stored.

When you switch on the fan subassembly, the fans start running. After approximately 10 s the current status of the fans is indicated via LEDs and relays.

9.4 The 24 VDC Fan Subassembly; (6ES7408-1TA00-0XA0)

Operator Controls and Indicators on the 24 VDC Fan Subassembly

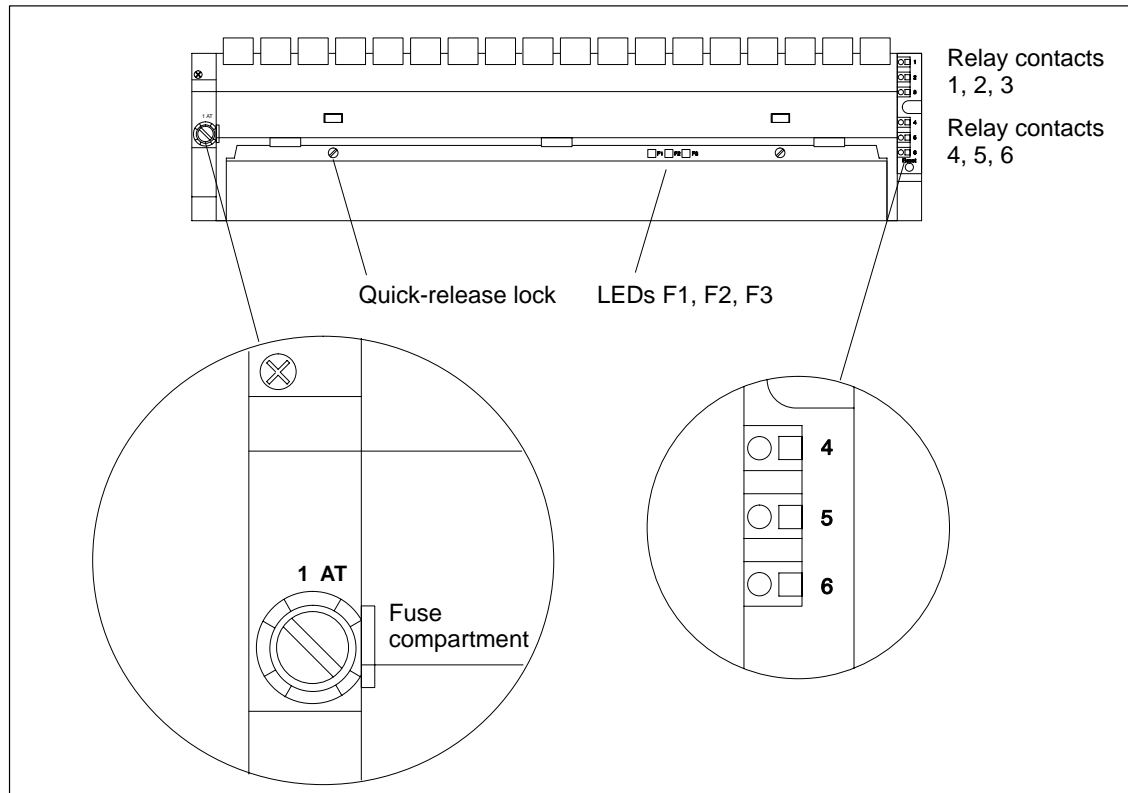

Figure 9-4 Controls and Indicators of the Fan Subassembly 24 VDC (6ES7408-1TA00-0XA0)

Characteristics

The 24 VDC fan subassembly has the same construction and functional characteristics as the 120/230 VAC fan subassembly.

Installation

Installing the 24 VDC fan subassembly is the same as for the 120/230 VAC fan subassembly.

Wiring

You connect the 24 VDC fan subassembly to the 24 VDC supply in the same manner as for the 120/230 VAC fan subassembly. You should note the polarity of the spring connections L+ and L-.

Signaling Concept

The signaling concept of the 24 VDC fan subassembly is identical to the signaling concept of the 120/230 VAC fan subassembly.

Fuse

Included in this fan subassembly are standard cartridge fuse links, 5 x 20 mm, conforming to DIN

- 1.0 AT for 24 V

The fuse is already installed on shipping from the factory.

Shielding Clamps

If you do not require the shielding clamps supplied, do not install them in the fan subassembly.

Technical Specifications

| Dimensions, Weights | | Voltages, Currents, Potentials | |
|--|-----------------|--------------------------------|----------------------------|
| Dimensions WxHxD (mm) | 482.5x109.5x235 | Input voltage | |
| Weight | appr. 2000 g | • Nominal value | DC 24 V |
| Kabeldurchmesser | 3 bis 9 mm | • Valid range | Static 19.2 V up to 30 V |
| Nominal Sizes | | | Dynamic: 18.5 up to 30.2 V |
| Lifespan of the fans | | Starting current | 0.9 A at 24 V |
| • at 40 °C | 70000 h | Fuses | 1.0 AT |
| • at 75 °C | 25000 h | Power consumption | |
| Max. contact load of relay contacts 1 to 6 | | • with fan | 12 W |
| • Switching voltage | 24 VDC | • without fan | 1.4 W |
| • Switching current | 200 mA | | |



Caution

Danger of damage to equipment.

If you insert the monitoring PCB in the wrong position in the fan subassembly, the fan subassembly may be damaged.

During maintenance of the unit, make sure you do not replace the monitoring PCB in the wrong position.

Monitoring Function

In the case of a fault (defective fans) the fans are not switched off. Once you have replaced the defective fan(s), the fault is acknowledged automatically as soon as the fans have reached the required speed. Any faults that occur are not stored.

When you switch on the fan subassembly, the fans start running. After approximately 10 s the current status of the fans is indicated via LEDs and relays.

RS 485 Repeater

In this Chapter

In this chapter, you will find a detailed description of the RS 485 repeater.

Included in the description are:

- The purpose of the RS 485 repeater
- The maximum cable lengths possible between two RS 485 repeaters
- The functions of the individual operating elements and terminals
- Information about grounded and non-grounded operation
- Technical specifications and the block diagram

Further Information

You will find further information on the RS 485 repeater in the manuals *Hardware and Installation* in the Chapter “Configuring of an MPI or PROFIBUS DP network”.

Chapter Overview

| Section | Description | Page |
|---------|--|------|
| 10.1 | Application and Characteristics; (6ES7972-0AA01-0XA0) | 10-2 |
| 10.2 | Appearance of the RS-485 Repeater; (6ES7972-0AA01-0XA0) | 10-3 |
| 10.3 | RS 485 Repeater in Ungrounded and Grounded Operation | 10-4 |
| 10.4 | Technical Specifications | 10-6 |

10.1 Application and Characteristics (6ES7972-0AA01-0XA0)

What is an RS 485 Repeater?

The RS 485 repeater amplifies data signals on bus lines and interconnects bus segments.

Application of the RS 485 Repeater

You need an RS 485 repeater if:

- more than 32 nodes are connected to the bus
- bus segments are to be operated non-grounded on the bus, or
- the maximum cable length of a segment is exceeded. (See table 10-1).

Table 10-1 Maximum Cable Length of a Segment

| Baud Rate | Max. Cable Length of a Segment (in m) |
|--------------------|---------------------------------------|
| 9.6 to 187.5 kbaud | 1000 |
| 500 kbaud | 400 |
| 1.5 Mbaud | 200 |
| 3 to 12 Mbaud | 100 |

Rules

If you configure the bus with RS 485 repeaters:

- Up to 9 RS 485 repeaters can be connected in series.
- The maximum cable length between two nodes must not exceed the values in Table 10-2.

Table 10-2 Maximum Cable Length between Two RS 485 Repeater

| Baud Rate | Maximum Length of Cable between 2 Nodes (in m) with RS 485 Repeater (6ES7 972-0AA01-0XA0) |
|--------------------|---|
| 9.6 to 187.5 kbaud | 10000 |
| 500 kbaud | 4000 |
| 1.5 Mbaud | 2000 |
| 3 to 12 Mbaud | 1000 |

10.2 Appearance of the RS 485 Repeater; (6ES7972-0AA01-0XA0)

The table below shows the appearance of the RS 485 repeater and lists its functions.

Table 10-3 Description and Functions of the RS 485 Repeater

| Repeater Design | No | Function |
|-----------------|----|--|
| | ① | Connection for the RS 485 repeater power supply (pin "M5.2" is the ground reference, if you want to measure the voltage difference between terminals "A2" and "B2"). |
| | ② | Shield clamp for the strain relief and grounding of the bus cable of bus segment 1 or bus segment 2 |
| | ③ | Terminals for the bus cable of bus segment 1 |
| | ④ | Terminating resistance for bus segment 1 |
| | ⑤ | Switch for OFF operating mode (= isolate bus segments from each other – for example, for startup) |
| | ⑥ | Terminating resistance for bus segment 2 |
| | ⑦ | Terminals for the bus cable of bus segment 2 |
| | ⑧ | Slide for mounting and removing the RS 485 repeater on the standard rail |
| | ⑨ | Interface for programming device/OP in bus segment 1 |
| | ⑩ | LED 24 V supply voltage |
| | ⑪ | LED for bus segment 1 |
| | ⑫ | LED for bus segment 2 |

10.3 RS 485 Repeater in Ungrounded and Grounded Operation

Grounded or Ungrounded

The RS 485 repeater is ...

- grounded, if all other nodes in the segment are also operated with a grounded potential
- ungrounded, if all other nodes in the segment are operated with an ungrounded potential

Note

The bus segment 1 is grounded if you connect a programming device to the PG/OP socket of the RS 485 repeater. Ground connection is effected since the MPI in the programming device is grounded and the PG/OP socket is connected internally with bus segment 1 in the RS 485 repeater.

Grounded Operation of the RS 485 Repeater

For grounded operation of the RS 485 repeater, you must jump terminals “M” and “PE” on the top of the RS 485 repeater.

Ungrounded Operation of the RS 485 Repeater

For ungrounded operation of the RS 485 repeater, “M” and “PE” on the top of the RS 485 repeater must not be interconnected. In addition, the supply voltage of the RS 485 repeater must be ungrounded.

Terminal Connection Diagram

In the case of a repeater configuration with ungrounded reference potential (ungrounded operation), any interference currents and static charges are discharged by means of an RC network integrated in the repeater (refer to Figure 10-1) to the protective conductor.

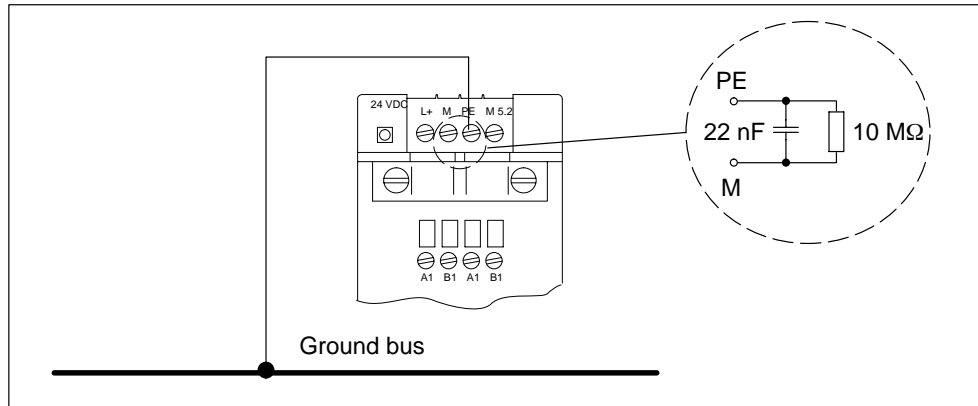

Figure 10-1 RC Network with 10 MΩ for Configuration with Ungrounded Reference Potential

Isolation Between Bus Segments

Bus segment 1 and bus segment 2 are galvanically isolated from each other. The PG/OP interface is connected internally to the port for bus segment 1. Figure 10-2 shows the front panel of the RS 485 repeater.

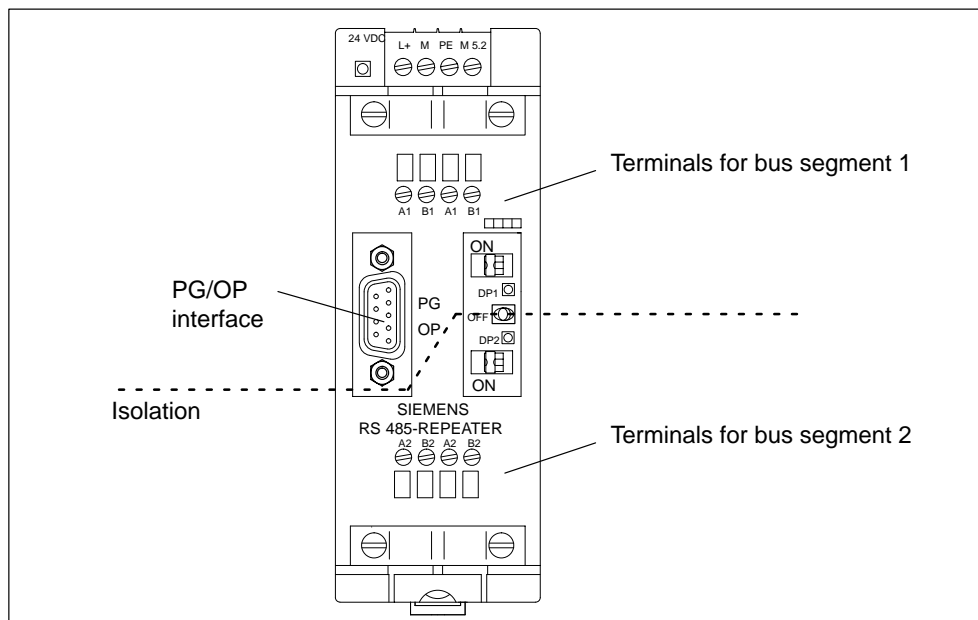

Figure 10-2 Isolation Between the Bus Segments

Amplification of the Bus Signals

The amplification of the bus signals takes place between the port for bus segment 1 or the PG/OP interface and the port for bus segment 2.

10.4 Technical Specifications

Technical Specifications of the RS 485 Repeater

| Technical Specification | |
|--|--|
| Power supply | |
| <ul style="list-style-type: none"> Rated voltage Ripple | 24 VDC 20.4 to 28.8 VDC |
| Current consumption at rated voltage | |
| <ul style="list-style-type: none"> without node at PG/OP socket Node at PG/OP socket (5 V/90 mA) Node at PG/OP socket (24 V/100 mA) | 200 mA 230 mA 200 mA |
| Isolation | Yes, 500 VAC |
| Connection of fiber optic cables | Yes, via repeater adapters |
| Redundancy operation | No |
| Transmission rate (automatically detected by the repeater) | 9.6 kbaud, 19.2 kbaud, 45.45 kbaud, 93.75 kbaud, 187.5 kbaud, 500 kbaud, 1,5 Mbaud, 3 Mbaud, 6 Mbaud, 12 Mbaud |
| Degree of protection | IP 20 |
| Dimensions W × H × D (in millimeters) | 45 × 128 × 67 mm |
| Weight (incl. packaging) | 350 g |

Pin Assignment of the Sub-D Connector (PG/OP Socket)

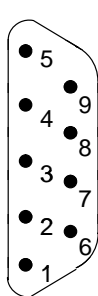
| View | Pin No. | Signal Name | Designation |
|---|---------|-------------|---|
|  | 1 | – | – |
| | 2 | M24V | Ground 24 V |
| | 3 | RxD/TxD-P | Data line B |
| | 4 | RTS | Request To Send |
| | 5 | M5V2 | Data reference potential (from station) |
| | 6 | P5V2 | Supply plus (from station) |
| | 7 | P24V | 24 V |
| | 8 | RxD/TxD-N | Data line A |
| | 9 | – | – |

Block Diagram of the RS 485 Repeater

- Bus segment 1 and bus segment 2 are galvanically isolated from each other.
- Bus segment 2 and the PG/OP socket are galvanically isolated from each other.
- Signals are amplified
 - between bus segment 1 and bus segment 2
 - between PG/OP socket and bus segment 2

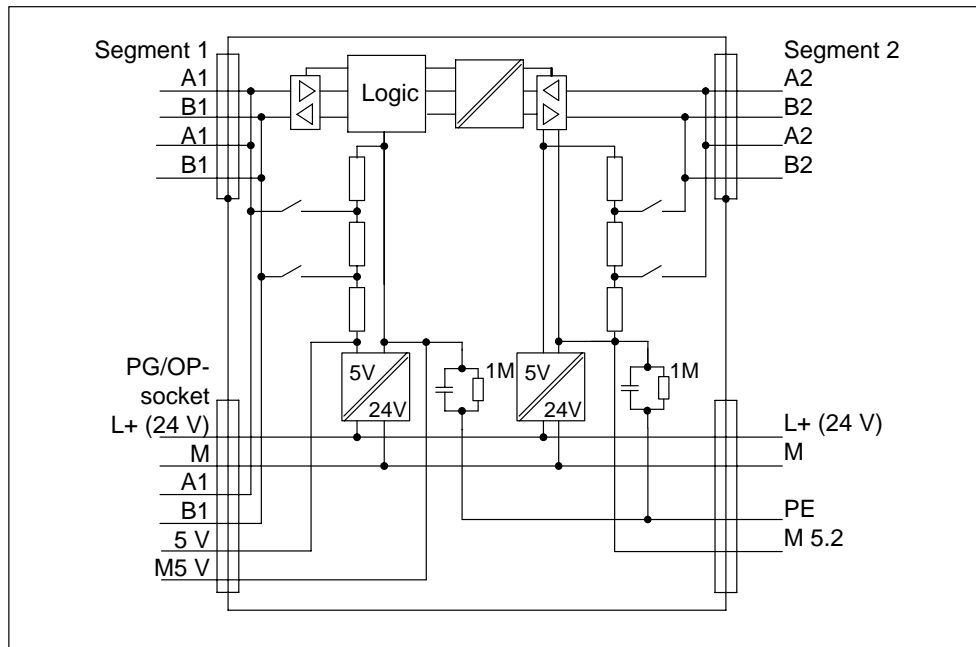

Figure 10-3 Block Diagram of the RS 485 Repeater

CPUs for M7-400

11

In this Chapter

This chapter describes the CPUs of the M7-400 automation computer:

- CPU 486-3,
- CPU 488-3,

The CPUs differ essentially in their clock frequencies. You will find a comparison of their performance features in Table 11-1.

The tables in Sections 11.1 and 11.2 give an overview of the performance features and technical specifications of the CPUs.

Following this overview, the modules are described in detail.

Chapter Overview

| Section | Description | Page |
|---------|--|-------|
| 11.1 | Performance Features | 11-2 |
| 11.2 | Technical Specifications | 11-3 |
| 11.3 | Function Elements | 11-4 |
| 11.4 | The BIOS Setup | 11-16 |
| 11.5 | I/O Addresses, Main Memory and Interrupt Assignments | 11-40 |

11.1 Performance Features

Introduction

There are two CPUs with different clock frequencies available for use with the automation computer.

Table 11-1 gives you an overview of the most important performance features of these CPUs.

Table 11-1 Performance Features of the CPUs

| Performance Features | CPU 486-3 (6ES7486-3AA00-0AB0) | CPU 488-3 (6ES7488-3AA00-0AB0) |
|---|---|---|
| Processor | Pentium 75 MHz | Pentium 120 MHz |
| MEM 478 DRAM memory submodules* for main memory <ul style="list-style-type: none"> • Expansion capability • Supply voltage | 16 Mbytes 3.3 V | 16 Mbytes 3.3 V |
| Second-level cache | No | 250 Kbytes |
| Submodule receptacle for memory card | Yes | |
| Submodule receptacles for interface submodules | 2 | |
| Connection of expansions | Max. 3 | |
| MPI | Yes | |
| Watchdog * | Yes | |
| * see M7-SYS User Manual | | |

11.2 Technical Specifications

The following table contains the technical specifications of the CPUs for the M7-400 automation computer.

Table 11-2 Technical Specifications of the CPUs

| | CPU 486-3 (6ES7486-3AA00-0AB0) | CPU 488-3 (6ES7488-3AA00-0AB0) |
|--|---|---|
| Nominal voltage | 5 VDC (4.75 to 5.25 VDC) | |
| Typical current consumption | 2.75 A | 3.0 A |
| Maximum permissible power consumption | 3.25 A | 3.5 A |
| Maximum permissible power losses | 16.25 W | 17.5 W |
| Maximum permissible power losses with interface submodules | 19.25 W | 20.5 W |
| Forced ventilation required | No | |
| Weight | 1300 g | |
| Dimensions W x H x D (mm) | 50 x 290 x 219 | |

11.3 Function Elements

Introduction

In this section you will become familiar with the individual function elements of the CPU 486-3 and CPU 488-3. You require the information here to be able to respond to displays, start up, and operate an M7-400 automation computer and handle further components (for example, memory cards, expansions).

In addition, you will find information on the watchdog, the BIOS setup and the address assignments and interrupt assignments.

General View

Figure 11-1 shows the front and rear view of the CPU 486-3 and CPU 488-3 without covering flap. The positions of the indicators, operator controls, and other elements required for operation can be seen from this figure.

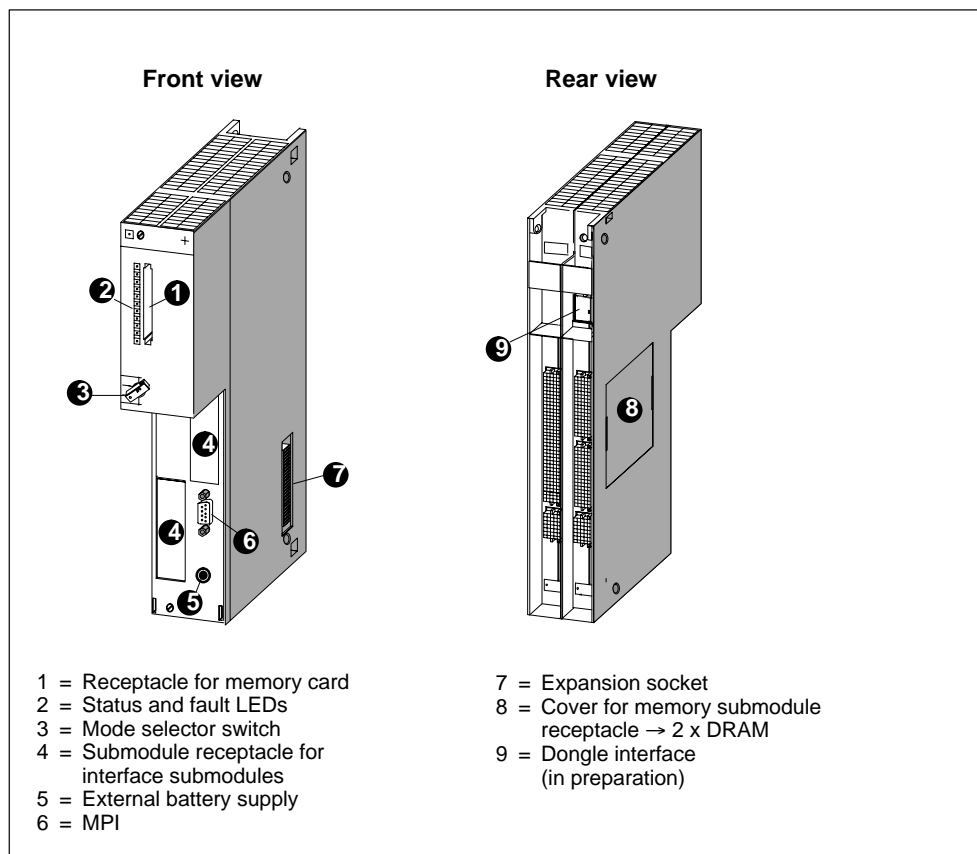

Figure 11-1 Front and Rear View of a CPU 486-3 and CPU 488-3 without Covering Flap

CPU Elements

The following table gives the meanings of the individual elements of the CPU 486-3 and CPU 488-3.

Table 11-3 Elements of the CPU 486-3 and CPU 488-3

| Element | Meaning |
|--|--|
| Status and fault LEDs | The status and fault LEDs indicate the operating state of your CPU. See page 11-6 for more detailed explanations. |
| Submodule receptacle for memory card | A long memory card can be inserted in the submodule receptacle. The system and user software can be loaded from this card into the main memory during startup. See page 11-8 for more detailed explanations. |
| Mode Selector | The mode selector switch is a key switch. See page 11-9 for more detailed explanations. |
| Submodule receptacles for interface submodules | Interface submodules can be plugged into these submodule receptacles. See page 11-11 for more detailed explanations. |
| Main memory | The main memory is freely accessible via a cover on the left-hand side of the housing. This allows problem-free insertion and replacement of memory submodules. See page 11-13 for more detailed explanations. |
| Expansion socket | Expansions such as the EXM expansion module, AT adapter module, ATM and MSM mass storage can be connected via the expansion socket. See page 11-14 for more detailed explanations. |
| MPI (9-pin sub D socket) | The CPU 486-3 and CPU 488-6 are equipped with a multipoint interface. See page 11-15 for more detailed explanations. |
| External battery supply | An external battery can be connected via this socket so that, for example, the contents of the SRAM and the time of day are not lost if the power supply fails. The same technical details apply as for the S7-400 CPUs. |

11.3.1 Status and Fault LEDs

Status and Fault LEDs

The CPU 486-3 and CPU 488-3 have the following status and fault LEDs:

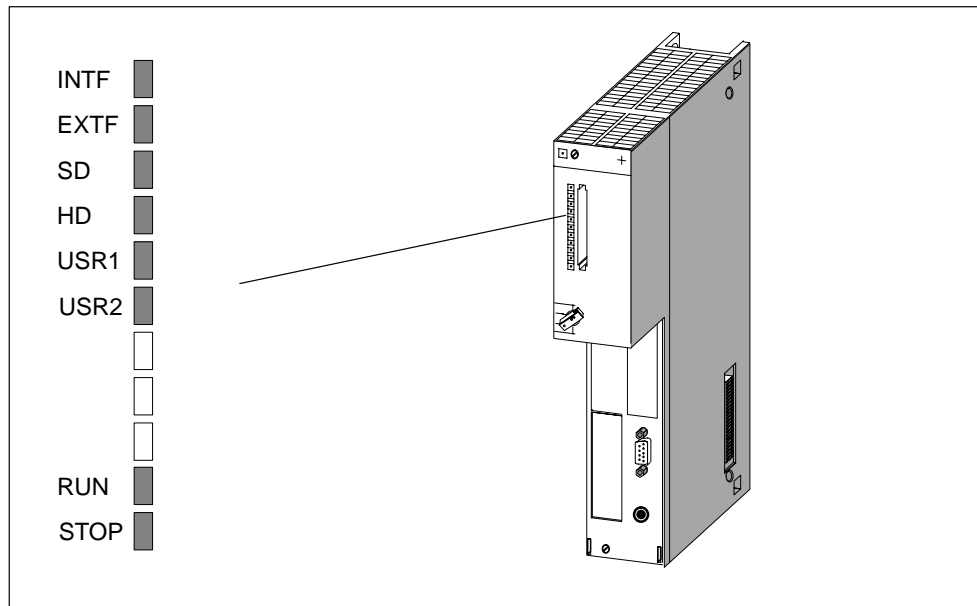

Figure 11-2 Status and Fault LEDs on the CPU 486-3 and CPU 488-3

Meaning of the Status and Fault LEDs

The status and fault LEDs are explained in Table 11-4 in the order in which they are arranged on the CPU 486-3 and CPU 488-3 modules. The following status and fault LEDs are available:

Table 11-4 Meaning of the Status and Fault LEDs on the CPU 486-3 and CPU 488-3

| LED | Meaning | Explanations |
|--------------------------|--|---|
| INTF (red) EXTF (red) | Internal or external fault indicator | Lights up in the event of: <ul style="list-style-type: none"> • Hardware faults • Firmware faults • Programming faults • Parameter assignment faults • Computational faults • Timer faults • Memory card faults • I/O faults Use the programming device for precise fault-finding (read out diagnostic buffer). |
| SD (green) | Access to memory card | Lights up if read or write access to the memory card is taking place. |
| HD (green) | Hard disk access | Lights up if read or write access to the hard disk of the mass storage module is taking place |
| USR1 (yellow) | Special LED for the user program (User) | Can be assigned by the user (see Programming Manual) |
| USR2 (yellow) | Special LED for the user program (User) | |
| RUN (green) | “ RUN ” state LED | Lights up if the system software is loaded and user programs are running (I/O access enabled). |
| STOP (yellow) | “ STOP ” state LED | <ul style="list-style-type: none"> • Lights up when the user program of the programmable module is not controlling the process (I/O access disabled) • Flashes when a memory reset is requested or is being performed |

11.3.2 Memory Cards

Introduction

The CPU 486-3 and CPU 488-3 offer the possibility of operating a memory card in the same way as a diskette. In this section, you will learn how you can use these options.

Note

If the power fails during a write access to the memory card, the entire contents of the memory card can be damaged under unfavorable conditions.

Please note that in contrast to a diskette, a memory card is only designed for a limited number of write accesses.

Memory Card

A memory card emulates a diskette from which an operating system can also be booted. In addition, a memory card can also be used to exchange user software and user data.

Memory cards with Flash EPROM are available for the CPUs (see the ordering data).

Drive Assignment

The memory card is accessed by the operating system in the same way as a conventional drive.

You can set the drive assignment in the BIOS setup (Section 11.4.11, page 11-35).

Boot Sequence

You can set the boot sequence in the BIOS setup (Section 11.4.12, page 11-36).

Formatting

Memory cards are formatted with the program **FTLFORM.EXE** included with the system software. Read the relevant sections in the *M7-SYS User Manual*.

Note

The memory capacity specified for the memory card is the actual physical memory capacity (gross). Formatting reduces the gross memory capacity to approximately 80% (net) that is then available to the operating system for storing data/programs.

UNDELETE: Files which were deleted from the memory card cannot be restored using UNDELETE programs.

11.3.3 Mode Selector Switch

Mode Selector Switch

The mode selector switch of the CPUs is a keyswitch.

You can see the positions of the mode selector switch in the following figure.

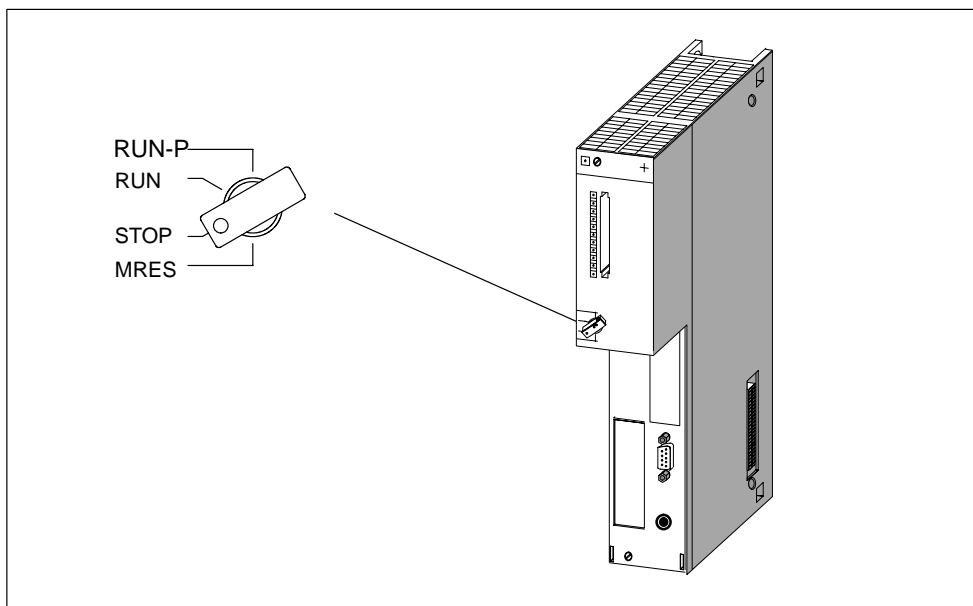

Figure 11-3 Mode Selector Switch

Positions of the Mode Selector Switch

The positions of the mode selector switch are explained in Table 11-5 in the order in which they are arranged on the CPUs.

Table 11-5 Positions of the Mode Selector Switch

| Position of the Mode Selector Switch | Explanations |
|--------------------------------------|--|
| RUN-P | The CPU executes the user program. The key cannot be removed in this position. Write and read access to the CPU are possible. |
| RUN | The CPU executes the user program. Read access only to the CPU is possible. The key can be removed in this position to prevent any unauthorized persons from changing the operating mode. |

Table 11-5 Positions of the Mode Selector Switch

| Position of the Mode Selector Switch | Explanations |
|--------------------------------------|---|
| STOP | I/O access is disabled for the user program of the CPU. The user program cannot control the process. The key can be removed in this position to prevent any unauthorized persons from changing the operating mode. |
| MRES | Position of the keyswitch for software-controlled resetting of the CPU (hardware reset). |

Activating MRES

To generate a hardware reset via MRES, follow the steps outlined below:

1. Turn the mode selector switch to the STOP position.

Result: The STOP LED lights up.

2. Turn the mode selector switch to the MRES position and hold it there.

Result: The STOP LED goes dark for a second, lights up for a second, goes dark again, and then remains lit.

3. Turn the switch back to the STOP position and then, in the next 3 seconds, to the MRES position again and back to STOP.

Result: The STOP LED flashes for approximately 3 seconds at 2 Hz (a memory reset is being carried out) and then remains lit.

4. If the STOP LED does not flash or other LEDs light up or flash, you must repeat steps 2 and 3.

Note

Resetting by activating MRES is controlled by the system software. If this has not been started, the CPU must be reset by switching the power supply off and on. If a keyboard is connected to the CPU, it is also possible to initiate a complete restart via hot keys (see Table 11-7 on page 11-19).

11.3.4 Submodule Receptacles for Interface Submodules

Submodule Receptacle Definition

The submodule receptacle is a slot for a submodule. The CPU 486-3 and CPU 488-3 have a receptacle for the memory card and two submodule receptacles for interface submodules.

Figure 11-4 shows the position of the two receptacles for interface submodules on the CPU 486-3 and CPU 488-3.

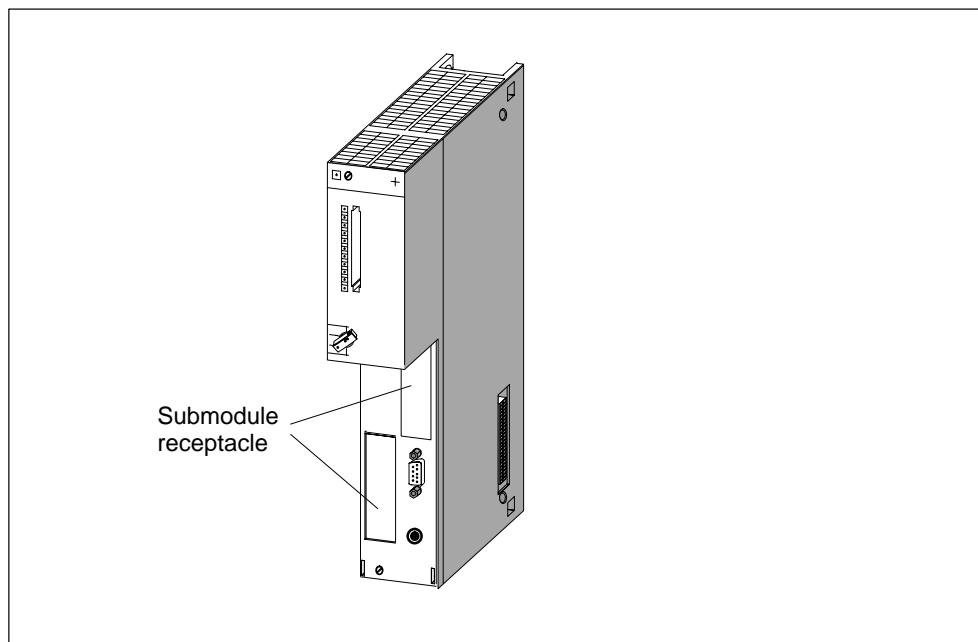

Figure 11-4 Position of the Receptacles for Interface Submodules on the CPU 486-3 and CPU 488-3

Numbering on the Submodule Receptacles

Each receptacle for an interface submodule has a submodule receptacle number assigned to it. The submodule receptacle number depends on the module slot and on the arrangement of the receptacle on the expansion module or the CPU. You can see the submodule receptacle numbers in Figure 11-5.

You require these submodule receptacle numbers for configurations that you undertake in the BIOS setup or for determining the I/O addresses of an interface module (see the Chapter “M7-400 Expansions”).

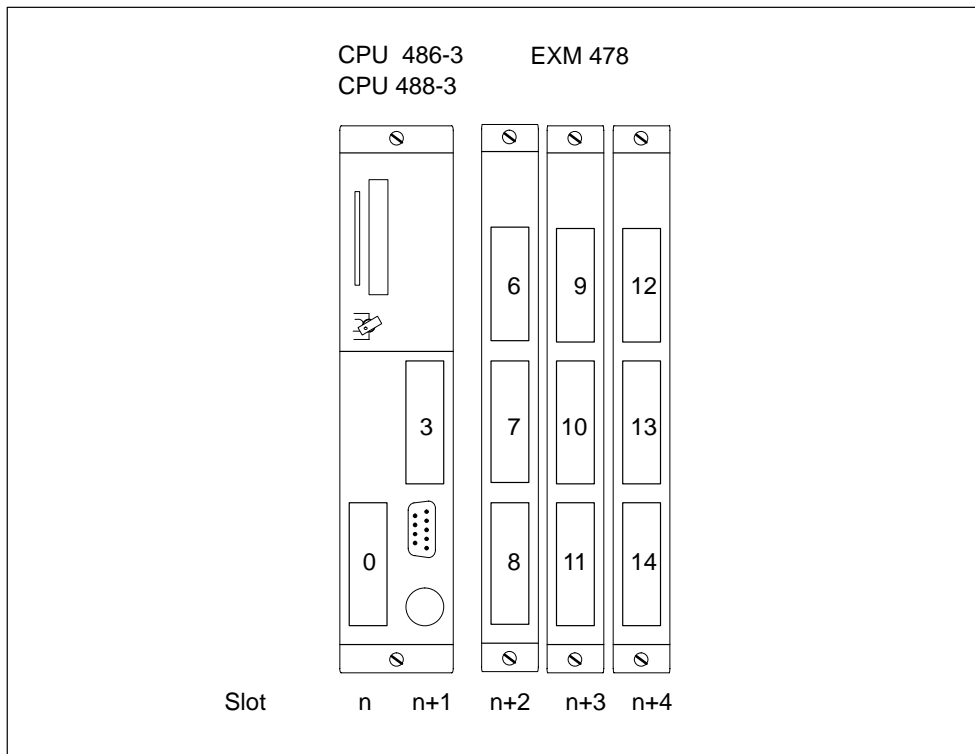

Figure 11-5 Submodule Receptacle Numbers on the CPU486-3/CPU488-3 and EXM478

Submodule Covers

Unused submodule receptacles are protected by submodule covers.

11.3.5 Memory Submodules Suitable for the Main Memory

Introduction

You must order the MEM 478 DRAM memory submodules for the main memory of the CPUs separately. They are also shipped separately. These memory submodules must be inserted before plugging into the mounting rack.

Main Memory Expansion

You can see from Table 11-6 which memory submodules you can use in which CPU.

Table 11-6 Main Memory Expansion Possibilities

| MEM478 DRAM Memory Submodules | CPU 486-3 | CPU 488-3 |
|-------------------------------|-----------|-----------|
| 2 x 8 Mbytes, 3.3 V | • | • |



Warning

DRAM memory submodules can be damaged.

If you use memory submodules for the main memory other than the DRAM submodules designed for the purpose, the submodules can be damaged.

Use only the MEM 478 DRAM memory submodules for the main memory.

Inserting the Memory Submodules

The sections “Installing an M7-400” and “Replacing Modules and Submodules” in the User Manual explain how to insert or replace the memory submodules.

11.3.6 Expansion Socket

Introduction

The CPU 486-3 and CPU 488-3 are each equipped with an expansion socket. The ISA bus is continued via the expansion socket.

Which Expansions Can Be Connected?

One EXM 478 extension module with up to three interface submodules, one MSM 478 mass storage module with diskette and hard disk drives, or one ATM 478 AT adapter module for short AT cards can be connected direct to the CPUs.

A total of up to three expansions can be connected in series to the CPU.

If three EXM 478 expansion modules are connected, up to 11 interface submodules can be operated together with the slots on each CPU (see Section 11.3.4).

11.3.7 Multipoint Interface (MPI)

X1 Interface

The X1 interface of the CPU 486-3 and CPU 488-3 for connecting devices such as PCs/programming devices is a multipoint interface (MPI) and is connected via a 9-pin sub D connector.

Suitable Devices

You can connect the following at the MPI:

- Programming devices (PGs/PCs)
- Operator panels (OPs)
- Additional CPUs.

You can address up to 127 communications partners (programming devices, OPs, CPUs) via the multipoint interface of the CPU 486-3 and CPU 488-3. A maximum of 44 connections can be made to the CPU.

Connectors

Use only bus connectors or PG cables for connecting devices to the MPI (see Chapter 6).

11.4 The BIOS Setup

Overview

The BIOS setup handles the configuration of the relevant CPUs in your M7-400 system. The settings and technical information concerning the configuration of this programmable module are displayed in the BIOS setup. The CPUs already have a default setup. It is set in such a way that the minimal configuration of a CPU (with memory card drive) will power up via BIOS setup without programming.

You can change the default settings in the BIOS setup. This becomes necessary if, for example, you want to connect expansions to your CPU (expansion module with interface submodules, mass storage module with diskette and hard disk drives, or AT adapter module with short AT card). You must inform the operating system of these expansions.

If you want to make settings in the BIOS setup, you can do so:

- Directly at the relevant module if your M7-400 is equipped with interface submodules and I/O devices such as a monitor and keyboard (interface submodule IF 962-VGA).
- Remote setup with a terminal program (for example, HyperTerminal under Windows 95) on programming device/PC or with an ANSI terminal via the COM1 port (interface submodule IF 962-COM).

Remote Setup

To run BIOS settings via the Remote Setup without the interface submodule IF 962-VGA, follow the steps outlined below:

1. Switch off the line voltage to your M7-400.
2. Connect the programming device to the COM1 port of the SIMATIC M7 device (see Section 8.7.2 of the Installation Manual).
3. On your programming device under Windows 95 select "Start > Accessories > Hyperterminal".
4. In the HyperTerminal window, select the menu command "File > New Connection". Enter a connection description and select the COM port with the following transmission properties: 19000 bps, 8 data bits, no parity, 1 stop bit, no flow control.
5. Switch on the line voltage to the M7-400 and hold the "Q" key pressed during startup until the M7-400 registers itself in the HyperTerminal with the hardware tests (a "U" appears).
6. Press the ESC button immediately.

Result: You are in the BIOS setup.

11.4.1 BIOS Power Up

Power Up without Error Message

After switching on or after warm restart of the CPU, the BIOS (Basic Input Output System) starts a "Power On Self Test" (POST) and displays the results in the POST window.

```

PowerBIOS Version 1.00
Copyright (C) 1984-1996, Award Software, Inc.
03/13/96 - Intel-82430HX-3A59I000 01 0000

Siemens AG M7-CPU M7-BIOS A2.00m

CPU Type.....Pentium 120Mhz
Math CoProcessor.....Internal
Base Memory.....640 Kb
Extended Memory.....31744 Kb
BIOS Shadow RAM.....Enabled
Video Shadow RAM.....Enabled
PS2 Mouse.....Disabled
Floppy Drives.....1 Found
Hard Drive(s).....IBM-DBCA-2540
Serial Ports.....2 Found
Parallel Ports.....1 Found
Testing Base Memory.....512 Kb

Press ESC to enter setup

```

Figure 11-6 POST Window for a CPU 488-3

If no error occurs, all LEDs on the CPU are switched off with the exception of the STOP LED.

Power Up with Warnings

During power up, warnings are given in the POST window after the "Video Shadow RAM..." line if:

- The battery power is missing
- There is no keyboard
- The CMOS checksum is wrong.

The warnings remain for 2 seconds. After this, the first line is suppressed from the POST window.

If battery power is missing, the date is reset to 1.1.1994.

Power Up with Error Message

If one of the following errors occurs:

- Memory test error
- Hard disk configuration error
- CMOS checksum error,

the INTF LED remains lit as well as the STOP LED. A window appears on the screen with the relevant error message. The window disappears after approximately two seconds and the power up continues.

With an incorrect CMOS checksum, the default settings are loaded.

Behavior in the Event of Serious Errors

In the case of serious errors, the power up is stopped. Serious errors include:

- No memory plugged in.
- More than one IF962-VGA interface submodule has been plugged in (INTF LED lights up).
- The CMOS memory location 15 (0xF) contains an invalid shutdown code during the warm restart.

These errors prevent screen output since the video unit is not initialized. The INTF LED lights up.

Ensure that the MEM 478 DRAM memory submodules required for operation are plugged into the CPU or check to see if more than one IF262-VGA interface submodule has been plugged into the CPU. If you do not find an error, there must be an invalid shutdown code. If this is the case, reset the CPU using power off/on.

Warm Restart

After a warm restart of the CPU, the following window appears signaling an accelerated system power up (see Section 11.4.2 “BIOS Hot Keys”).

```
PowerBIOS Version 1.00
Copyright (C) 1984-1996, Award Software, Inc.
03/13/96 - Intel-82430HX-3A591000 01 0000

Siemens AG M7-CPU M7-BIOS A2.00m
Press CTRL-ALT-ESC to enter setup
```

Figure 11-7 Warm Restart Window for a CPU

11.4.2 BIOS Hot Keys

BIOS Hot Keys

After power up, the BIOS offers the user a range of functions under MS-DOS. These functions are executed by pressing the following groups of keys simultaneously:

Table 11-7 BIOS Hot Keys with German and English Key Assignments

| English Key Assignments | German Key Assignments | Function |
|-------------------------|------------------------|---|
| CTRL + Alt + DEL | STRG + Alt + ENTF | Warm restart of the module |
| CTRL + Alt + HOME | STRG + Alt + POS1 | Cold restart of the module (power off/on with initialization of all blocks) |
| CTRL + Alt + ↓ | STRG + Alt + ↓ | IDE hard disk in standby mode |
| CTRL + Alt + PGDN | STRG + Alt + Bild ↓ | Screen saver on (dark screen) |
| CTRL + Alt + PGUP | STRG + Alt + Bild ↑ | Screen saver off |

Note

These functions can be overlaid by other operating systems or user programs such as Windows.

11.4.3 Operator Inputs in the BIOS Setup







Definition of the Setup Fields

Within the BIOS setup, there are fields in which you can make entries or selections. These fields have the following functions:

- Editbox;
You can enter desired values in this field . The field content must be deleted first with or .
- List box;
This field lists, for example, all menu pages in the setup menu, from which you can select and start one.
- Check box;
You can switch on the associated function by activating the check box [] and switch it off again by deactivating the check box [] .
- Option button;
By activating an option button (✱) you can select one of a range of options. Activating another option button has the effect of deactivating the previous option button ().

Key Control within the Setup Menu

The following keys are used for control within the Setup menu and the associated setup page (conforming to the Windows™ Standard):

-  With this key, you jump to the first line of a list box, edit box, check box, or option button.
- If the cursor is at a button (OK, CANCEL, ...) or at a selected line (inverse video) within a list box, you can activate the function with .
- If the cursor is not at a button when you press  this executes the same function as an activated OK button: Return to the Setup menu with any changes made in the setup page being retained.
-  This key executes the same function as a CANCEL button: Return to Setup menu with any changes in the setup page being deleted.
-  With this key, you can move the cursor from one box to the next box or to the next button.
-   With this key, you can move the cursor from one box to the next box or to the next button (only locally, not under Remote Setup).



With the cursor control keys, you can jump from line to line within a list box. The line you are in is marked with a dark bar.

You can page with the cursor control keys within an edit box if there are several values available for selection within the box.

You activate an option button if you position the cursor at the button using the cursor control keys.



With the cursor control keys, you can jump from character to character within an edit box.

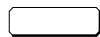

With the spacebar, you can confirm the selected lines as selected or activate a check box.

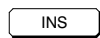

Holding the INSERT key pressed during a complete restart of the module leads to certain BIOS default settings being loaded which are required for a safe startup.

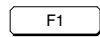

With this function key, a context-sensitive help window is displayed.

Figure 11-8 shows an example.

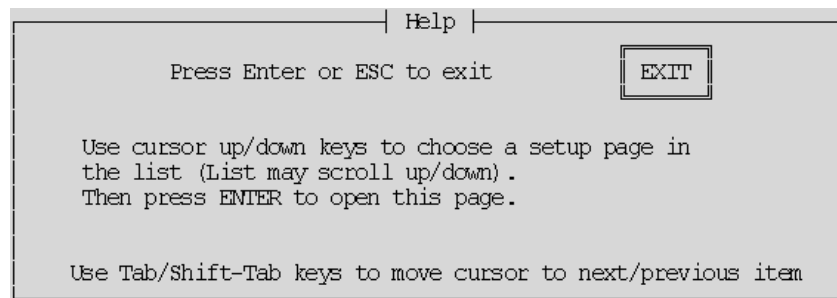

Figure 11-8 Context-Sensitive Help Window

The Remote Setup can either be operated with the keyboard of the remote computer or with the keyboard of the M7-400. In both cases the above key assignments apply.

In the edit windows:



sets the minimum value of the window.

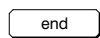

sets the maximum value of the window.

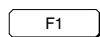

displays a context-sensitive help text.

11.4.4 Opening and Exiting the BIOS Setup

Opening the Setup Menu

To open the Setup menu, press the following keys simultaneously while the CPU is powering up and the POST window (Figure 11-6) is on the screen: + + or under Remote Setup.

The Setup menu then appears to allow you to select the setup pages.

Figure 11-9 shows the front and rear view of the CPU 486-3 and CPU 488-3 without covering flap.

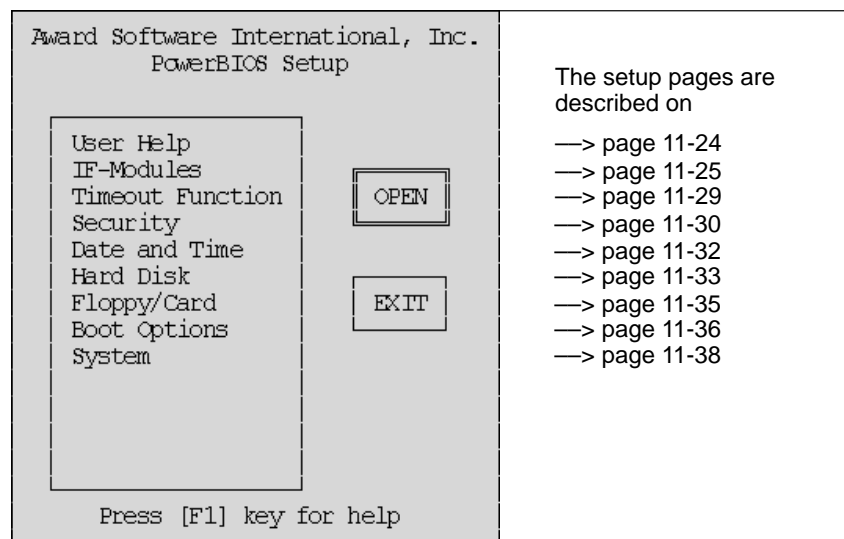

Figure 11-9 Setup Menu

The Setup menu consists of:

- A list box from which you can select the required setup page,
- An OPEN button which opens the selected setup page when activated,
- An EXIT button which closes the Setup menu after prompting you to decide whether changes are to be saved or not,

The setup pages for the CPU 486-3 and CPU 488-3 are shown below.

The setup pages below show the default settings.

Exiting the BIOS Setup

To exit the BIOS setup, activate the EXIT button shown in Figure 11-9 or press

. The "Setup Exit" dialog box then appears (see Figure 11-10).

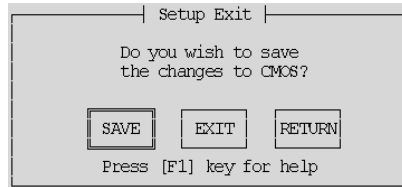

Figure 11-10 "Setup Exit" Dialog Box

Here you have the following choices:

- **SAVE**
saves the parameters to the CMOS and then runs a cold restart.
- **EXIT**
exits the setup without saving the parameters to the CMOS and then runs a cold restart (power off/on with initialization of all blocks).
- **RETURN**
returns to the setup. All changes that were made since Setup was opened are abandoned.

11.4.5 Setup Page "User Help"

Opening the Setup Page

If you have selected "User Help" and activated the OPEN button in the Setup menu (Figure 11-9 on page 11-23), this setup page appears on the screen (Figure 11-11).

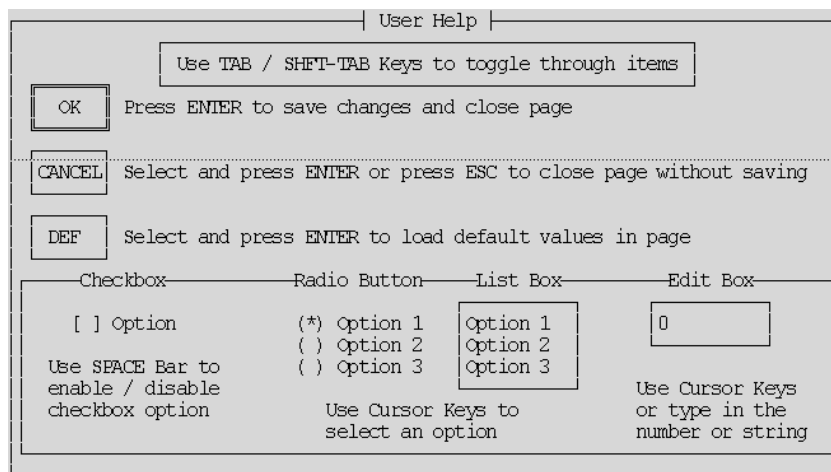

Figure 11-11 "User Help" Setup Page

What is the Purpose of the Setup Page?

This setup page contains notes that help you to use the Setup menu.

OK Button

Activating this button returns to the Setup menu.

11.4.6 Setup Page “IF modules”

Opening the Setup Page

If you have selected “IF Modules” and activated the OPEN button in the Setup menu (Figure 11-9 on page 11-23), this setup page appears on the screen (Figure 11-12)

| IF-Modules | | |
|---|---|--------|
| Select Module # 0 | I/O Base CD00 | OK |
| Type configured FF | 41 detected | CANCEL |
| Interrupt Source A FF E4 B FF E3 C FF FF Shared Dest. FF FF | DMA Request A FF FF B FF FF | |
| Config. Index 0 Value FF 36 | SIG Source 1 0 0 2 0 0 SIG Dest. 0 0 | |

Figure 11-12 “IF Modules” Setup Page

What is the Purpose of the Setup Page?

If you have expanded your CPU with expansion modules, you can configure the interface submodules used in the expansion modules on this setup page. See the “Interface Submodules” and “M7-400 Expansions” chapters for the settings you require.

You should only change the settings if you need to, otherwise the default settings should be used.

Representation of Information

Information cannot be edited. It is shown on this setup page in gray type. The gray type is not available in Remote Setup and is replaced there with black type.

Accepting Edited Values

Only the values for which the relevant interface submodule has been designed are accepted by the system in the edit boxes. If, for example, you enter three values under “Interrupt Source” and the interface submodule only has one interrupt, only the first value will be significant.

Any changed values are only saved when you confirm them with the key or with (only locally, not under Remote Setup).

Select Submodule Number

Here, you enter the consecutive number for the submodule receptacle containing the interface submodule or you select the number using the cursor control keys .

In the M7-400, you can enter submodule receptacle numbers 0 to 14 if the maximum possible three EXM 478 expansion modules are in use (see Section 12.2) Three submodule receptacle numbers are used per slot on the backplane bus.

The submodule receptacle number is linked to the other values on this setup page. If you change the submodule receptacle number, the associated values also appear, if they have been entered.

I/O Base (Gray Type)

Shows the current address of the expansion module (see Chapter 12 “M7-400 Expansions”) or CPU associated with the submodule receptacle. However, the double-width CPU has two addresses, one address for submodule receptacles in its left half and a second address, higher by + 100_H for the submodule receptacle in its right half. The information cannot be edited.

Type Configured + Detected (Gray Type)

At “Type configured,” you enter the type of interface submodule already plugged into this slot or still to be plugged in.

“Detected” indicates the type of interface submodule currently (at the last CPU power up) occupying this slot. The information cannot be edited.

The BIOS executes a SETPOINT/ACTUAL VALUE comparison. If the value set in “Type configured” does not agree with the value in “detected”, or if the value 0FFH has been configured in “Type configured”, the BIOS does not execute the configuration for this interface submodule.

If there is no interface submodule in the submodule receptacle, the value “FF” is displayed.

Interrupt Source

Here, you set interrupts A to C (see the “Interface Submodules” chapter) provided for the interface submodule. The values positioned on the left are setpoints. You can edit these. The value indicated in gray type to the right of these is the actual value (determined at the last CPU power up). It cannot be edited.

Note

For the IF 961-AIO, IF 961-DIO and IF 961-CT1 interface modules there are no default interrupts in the BIOS setup (default values are always 0xFF). Additionally, no error message is given if no interrupt is set for an interface module, which is configured for interrupt generation.

BIOS settings for interrupt capable interface modules

If you have set the interrupt generation for an interface module in the SIMATIC manager, you have to set an interrupt for this interface module in the BIOS setup page “IF modules”. For this, use an available interrupt (see above and Table 11-9 “Interrupt Assignment” on page 11-42).

Shared Dest.

Here, you set a shared interrupt for the interface submodule (see the “Interface Submodules” and “M7-400 Expansions” chapters). This value is entered only once per expansion module at the first submodule receptacle (0, 3, 6, 9, etc.). The value on the left-hand side is the setpoint value, which you can edit. The value indicated in gray type to the right of it is the actual value (determined at the last CPU power up). It cannot be edited.

DMA Request

Enter here the DMA request A and B for the interface submodule (see the “Interface Submodules” chapter). The values positioned on the left are setpoints. You can edit these. The value indicated in gray type to the right of these is the actual value (determined at the last CPU power up). It cannot be edited.

Config. Index

Here, you can address the 40 H configuration space of the interface submodules (0H to 3FH). You will find the address in the Table “Offset Address for the Configuration Register” of each interface submodule in the “Interface Submodules” chapter.

Value (Gray Type)

Under the address set with "Config. Index", you can now enter the configuration value. You will find this value and its significance in the chapter "Interface Submodules" under the relevant interface submodule.

The configuration value positioned on the left is the setpoint. You can edit this value. When you have entered it, confirm by pressing the key or the key combination , so that it is accepted. The configuration value shown to the right of this in gray type (black type in Remote Setup) is the actual value (determined at the last power up of the CPU). It cannot be edited. If there is no submodule in the submodule receptacle, the value "FF" is displayed.

SIG Source

Here, you enter the signal source if the relevant interface submodule is designed for it ("Interface Submodules" chapter). The values for the signal source positioned on the left are the setpoints. You can edit these. The values shown to the right of this in gray type (black type in Remote Setup) are the actual values (determined at the last power up of the CPU).

SIG Dest.

Here you enter the signal destination if the relevant interface submodule is designed for it ("Interface Submodules" chapter). This value is entered only once per expansion module at the first submodule receptacle (0, 3, 6, 9, etc.). The value for the signal destination positioned on the left is the setpoint. You can edit this value. The signal destination value shown to the right of this in gray type (black type in Remote Setup) is the actual value (determined at the last power up of the CPU). It cannot be edited.

OK Button

Returns to the Setup menu when activated. Changes on the setup page are retained.

CANCEL Button

Returns to the Setup menu when activated. Deletes all changes you have made on the setup page.

11.4.7 Setup Page “Timeout Function”

Opening the Setup Page

If you have selected “Timeout Function” in the Setup menu (Figure 11-9 on page 11-23) and activated the OPEN button, this setup page appears on the screen (Figure 11-13).

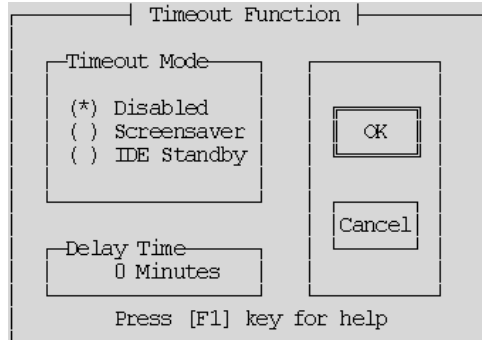

Figure 11-13 Setup Page “Timeout Function”

What is the Purpose of the Setup Page?

On this setup page, you determine whether the hard disk is to go into standby mode during access pauses or the screen is to be protected by a screen saver during entry pauses.

Timeout Mode

Timeout mode offers you the following possible selections:

| By Activating the Option Button... | You Can... |
|------------------------------------|---|
| Disabled | switch the timeout function off. |
| Screen saver | or have the screen saver switched on during entry pauses, |
| IDE Standby | or operate the hard disk in energy-saving standby mode during access pauses |

Delay Time

In this edit box, you enter the time in minutes that has to elapse after the last entry or the last hard disk access before the timeout function activates.

OK Button

Activating this button returns to the Setup menu. Changes on the setup page are retained.

CANCEL Button

Activating this button returns to the Setup menu. Deletes all changes you have made on the setup page.

11.4.8 Setup Page “Security”

Opening the Setup Page

If you have selected “Security” in the Setup menu (Figure 11-9 on page 11-23) and activated the OPEN button, this setup page appears on the screen (Figure 11-14).

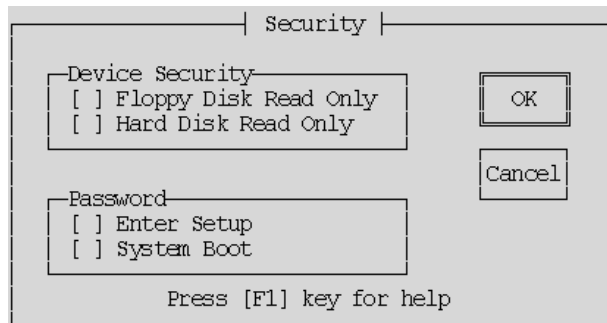

Figure 11-14 “Security” Setup Page

What is the Purpose of the Setup Page?

On this setup page, you activate or deactivate the write protection for the disk drive and hard drive and the password protection for setting up and/or booting the CPU.

Device Security

Floppy Disk Read Only

When this check box is activated, write access to the hard disk is no longer possible.

Hard Disk Read Only

When this check box is activated, write access to the hard disk is no longer possible.

Password

Enter Setup

By activating this check box, you can assign a password that authorizes access to the Setup.

System Boot

By activating this check box, you can assign a password that permits booting of the operating system.

You can only set this password if a valid password was already entered for "Enter Setup".

Note

The password can have a maximum of 8 alphanumeric characters. Upper and lower case are distinguished. If you use the American keyboard to enter the password and then change, for example, to using another national keyboard such as the German, this can have consequences for the password. For the password Johnny_* you would then have to enter Johnnz?

Write down your password and keep it in a safe place where you can find it again. If you lose or forget your password, contact your local Siemens dealer.

OK Button

Activating this button returns to the Setup menu. Changes on the setup page are retained.

CANCEL Button

Activating this button returns to the Setup menu. Deletes all changes you have made on the setup page.

11.4.9 Setup Page “Date and Time”

Opening the Setup Page

If you have selected “Date and Time” and activated the OPEN button in the Setup menu (Figure 11-9 on page 11-23), this BIOS setup page appears on the screen (Figure 11-15).

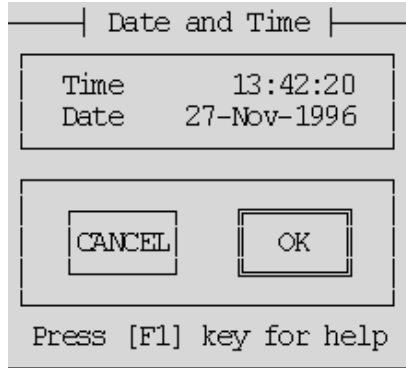

Figure 11-15 “Date and Time” Setup Page (Default)

What is the Purpose of the Setup Page?

On this setup page, you set the date and time for the programmable module.

Date

You enter the date in the form dd-mm-yyyy (day, month, year) in this edit box.

Time

You enter the time in the form hh:mm:ss (hour, minute, second) in this edit box.

The seconds in the setup page are updated continuously and only stopped when you select the seconds field. You can then accept the value displayed or set by pressing the key.

OK Button

Activating this button returns to the Setup menu. Changes on the setup page are retained.

CANCEL Button

Activating this button returns to the Setup menu. Deletes all changes you have made on the setup page with the exception of the time.

11.4.10 “Hard Disk” Setup Page

Opening the Setup Page

If you have selected “Hard Disk” and activated the OPEN button in the Setup menu (Figure 11-9 on page 11-23), this BIOS setup page appears on the screen (Figure 11-16).

| Primary IDE Controller | | | | | | | | | | | | |
|-------------------------------------|------|-----|-------|-----|---------|--------|------|--------|-------|-------|--------|------|
| Auto | Type | Cyl | Heads | SPT | Precomp | L-Zone | Size | Mode | Trans | Block | 32-Bit | Fast |
| <input checked="" type="checkbox"/> | USR1 | 525 | 32 | 63 | NONE | 1049 | 516 | LEA | | | | |
| <input type="checkbox"/> | NONE | 0 | 0 | 0 | 0 | 0 | 0 | Normal | | | | |

Figure 11-16 “Hard Disk” Setup Page with only the Master Hard Disk Present

What is the Purpose of the Setup Page?

The setup page is used for transferring the parameters of the hard disk in your mass storage module to the BIOS.

Only change the default settings if you install a different hard disk and this cannot be detected automatically (see Auto function). If the wrong hard disk type is entered, the operating system cannot be started.

AUTO All Drives

Sets the type and all parameters for the master and slave hard disks.

Auto

Sets the type and all parameters for the corresponding hard disk automatically during BIOS startup if the check box is activated.

Type Size

These are drive-specific parameters.

Translation Mode

In Translation Mode you have four possible settings:

- Auto
reads the hard disk parameters and automatically sets the correct mode (Normal, LBA, Large). The Translation Mode "Auto" is set as the default.
- Normal
used for hard disks with a memory capacity of ≤ 504 Mbytes.
- LBA (Logical Block Addressing)
is used for hard disks with a memory capacity of ≥ 504 Mbytes.
- Large
must be set for hard disks with a memory capacity of ≥ 504 Mbytes which do not support the LBA mode.

Block Mode

Sets the block mode for DMA transfers. As the hard disks in the M7-400 are not being operated in DMA mode, this check box should not be activated.

32 Bits

Sets 32-bit access mode. As this is not supported by ISA hard disk controllers, this check box should not be activated.

Fast PIO

Sets a faster Programmed Input Output mode.

OK Button

Activating this button returns to the Setup menu. Changes on the setup page are retained.

CANCEL Button

Activating this button returns to the Setup menu. Deletes all changes you have made on the setup page.

11.4.11 Setup Page “Floppy/Card”

Opening the Setup Page

If you have selected “Floppy/Card” and activated the OPEN button in the Setup menu (Figure 11-9 on page 11-23), this setup page appears on the screen (Figure 11-17).

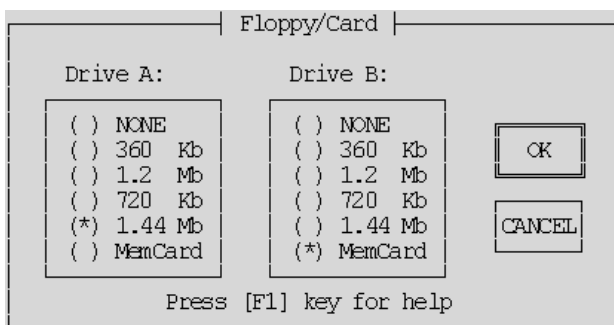

Figure 11-17 “Floppy/Card” Setup Page

What is the Purpose of the Setup Page?

You can enter the diskette (floppy disk) drive in your mass storage module and the memory card drive in your CPU on this page.

Drive A

At the first power up or after the key has been pressed during booting, the BIOS setup detects whether the CPU has been expanded by a mass storage module and whether it therefore has a floppy disk drive available or not.

- If a floppy disk drive is available, the BIOS assigns drive A to it by activating the option button “1.44 Mb”.
- If a floppy disk drive is not available, the BIOS assigns drive A to the memory card drive by activating the option button “MemCard”.

If you do not want either of the two drives entered, activate the option button “NONE”.

The other Drive A settings are not significant at the present time.

Drive B

Drive B stands only for the memory card drive within the CPU if a floppy disk drive is entered in Drive A.

- Activate the option button “MemCard” if you want to work with a memory card.
- Otherwise, activate the option button “NONE”.

The other Drive B settings are not significant at the present time.

OK Button

Activating this button returns to the Setup menu. Changes on the setup page are retained.

CANCEL Button

Activating this button returns to the Setup menu. Deletes all changes you have made on the setup page.

11.4.12 Setup Page “Boot Options”

Opening the Setup Page

If you have selected “Boot Options” and activated the OPEN button in the Setup menu (Figure 11-9 on page 11-23), this setup page appears on the screen (Figure 11-18).

```

Boot Options

Press [F1] key for help      [OK] [Cancel] [Default]

Boot Sequence
(*) A:, C:
( ) C:, A:

Keyboard State
[ ] Typematic Settings Enabled
Typematic Rate:      6 (char/s)
Typematic Delay:    250 (msec)
[V] Num Lock On

Halt On ...
( ) No Halt
( ) Keyboard Errors
( ) Disk Errors
(*) All Errors

System Memory
[V] Quick Memory Test
  
```

Figure 11-18 “Boot Options” Setup Page

What is the Purpose of the Setup Page?

On this page, you set the boot drive and the method for the main memory test.

Boot Sequence

By activating the relevant option button, you select here the drive from which the CPU is to boot at power up.

- Drive A represents the floppy disk drive or memory card, depending on which of them has been entered as Drive A in the “Floppy/Card” setup page. If there is no medium with boot capability in the floppy disk drive, the system will next try to boot from the memory card (“Floppy/Card” setup page → Drive B).
- Drive C represents the hard disk drive.

It is possible to designate a primary and secondary drive, that is, if there is no boot program in the primary drive, the system boots automatically from the secondary drive if there is a boot program there.

If neither Drive A nor Drive C contain a boot program, a message on the screen prompts you to insert a medium with boot capability and to confirm this by pressing .

Halt On ...

Here you can choose which error messages are displayed in an error window during booting. Displaying an error window delays booting by approximately 2 seconds.

Keyboard State**Typematic Settings Enabled**

If you activate this check box, the values "Typematic Rate" and "Typematic Delay" are set by the BIOS.

Typematic Rate

This value is used to set the maximum keyboard rate in characters per second.

Typematic Delay

This value is used to set the delay time in milliseconds, after which characters are transferred with the maximum keyboard rate.

Num Lock On

If you activate this check box, "Num Lock" becomes active after BIOS power up.

System Memory

If this check box is activated, only sample tests are made of the main memory at power up so the test is especially fast.

OK Button

Activating this button returns to the Setup menu. Changes on the setup page are retained.

CANCEL Button

Activating this button returns to the Setup menu. Deletes all changes you have made on the setup page.

DEFAULT Button

When this button is activated, the default settings are entered in the setup page again. The original settings are deleted.

11.4.13 Setup Page “System”

Opening the Setup Page

If you have selected “System” and activated the OPEN button in the Setup menu (Figure 11-9 on page 11-23), this setup page appears on the screen (Figure 11-19).

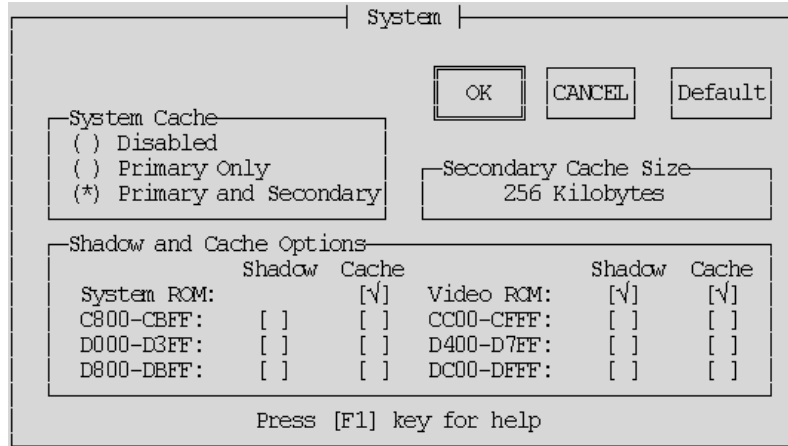

Figure 11-19 “System” Setup Page

What is the Purpose of the Setup Page?

On this page, you make the settings for the cache memory, the system ROM, and the video ROM. We recommend you use the default settings (see Figure 11-19).

System Cache

System Cache offers you the following possible selections:

| By Activating the Option Button... | You Can Switch... |
|------------------------------------|---|
| Disabled | all cache memory off, |
| Primary only | only the process-oriented cache on, |
| Primary and Secondary | both the internal and external cache on. If Size 0 is displayed for Secondary Cache, only the Primary Cache can be switched on. |

Secondary Cache Size

Indicates the size of the secondary cache memory. This field is for information only and cannot be edited.

System Cache

For the memory areas of the System ROM, the VIDEO ROM, and the addresses of BIOS expansions, you can set whether they are copied to the Shadow RAM and whether the cache should be used.

- System ROM offers you the following possible selections:

| By Activating the Option Button... | You Determine... |
|------------------------------------|--|
| Shadowed | that the BIOS address area of 128 Kbytes is to be copied into the high-speed shadow RAM. This option cannot be switched off. |
| Shadowed and Cached | that a cache memory is available for this memory area in addition to shadow RAM. |

Note

If you have switched off the cache memory in the “Primary and Secondary Cache” field, the setting in the “System ROM” field does not change automatically.

- Video ROM offers you the following possible selections:

| By Activating the Option Button... | You Determine... |
|------------------------------------|---|
| Shadowed | that the video ROM (32 Kbytes) is copied into the fast shadow RAM. This accelerates video output (faster screen buildup). |
| Shadowed and Cached | that a cache memory is available for this memory area in addition to shadow RAM. Further accelerates video output. |

OK Button

Activating this button returns to the Setup menu. Changes on the setup page are retained.

CANCEL Button

Activating this button returns to the Setup menu. Deletes all changes you have made on the setup page.

DEFAULT Button

When this button is activated, the default settings are entered in the setup page again. The original settings are deleted.

11.5 I/O Addresses, Main Memory and Interrupt Assignments

Introduction

This section gives you detailed information, in the form of a table, on the I/O address space assignment, main memory and interrupt assignments of the CPUs.

Memory Assignment

The main memory is assigned as follows in the M7-400:

Table 11-8 Main Memory Assignment

| Address | Content |
|--------------------|------------------------------------|
| 1 MB to 15 MB | User memory area |
| 15 MB to 16 MB | PROFIBUS DP*), otherwise free |
| E 8000H to F FFFFH | BIOS |
| E 0000H to E 7FFFH | Free (32 K) |
| D 0000H to D FFFFH | Free (64 K) |
| C F000H to C FFFFH | Free (4 K) |
| C C000H to C EFFFH | Memory card, otherwise free (12 K) |
| C 8000H to C BFFFH | Free (16 K) |
| C 0000H to C 7FFFH | Shadow VGA BIOS (32 K) |
| A 0000H to B FFFFH | VGA (128 K) |
| 0 0000H to 9 FFFFH | 640 K system area |

*) If the interface submodule IF 964-DP is not plugged in the preferred slot (see Table 13-3 on page 13-4)

Keeping Memory Areas Free

The memory areas that are not always marked as “free” should be kept free when using a memory manager.

SRAM Area

The size of the SRAM with battery backup is 64 Kbytes (net for data blocks 56 Kbytes). If the battery is removed and inserted again when there is no power connected, the SRAM content will be lost. This is indicated by the BAF LED.

Memory Areas for AT Cards

AT cards which are inserted in the expansion module ATM 478 can occupy the following memory areas:

| Range | M7 RMOS32 | M7 RMOS32 with MS-DOS | | M7 RMOS32 with MS-Windows |
|-----------------------------------|-----------|-----------------------|--------------------|---------------------------|
| | | Without EMS | With EMS | |
| D 0000H to E 7FFFH | 96 K | 96 K | 32 K ²⁾ | 32 K ²⁾ |
| C 8000H to C BFFFH | 16 K | 16 K | 16 K | 16 K |
| C C000H bis C EFFFH ¹⁾ | 12 K | 12 K | 12 K | 12 K |
| C F000H to C FFFFH | 4 K | 4 K | 4 K | 4 K |

- 1) The area is only available if no memory card is present.
- 2) Under M7 RMOS32 with MS Windows, or if the driver software under MS-DOS requires expanded memory (EMS), the memory manager EMM386 occupies 64K in the area D0000H to E7FFFH because it must be operated in EMS mode.

I/O Address Area

Addressing the ISA-compatible input/output components is done in the I/O area under the addresses from 0100_H to 03FF_H. The addresses specified by the ISA architecture are used here. In contrast to the original AT, the I/O addresses in the CPUs are completely decoded so that the addresses above 03 FF_H can be used for addressing M7-400-specific hardware.

I/O Address Area for AT Adapter Modules

If you are using AT adapter modules, the following address areas are available for addressing:

- 0200_H to 03FF_H
- Except for the area 3 E0H to 3 E3H and
- Except for the areas which the interface submodules are occupying (see the "Interface Submodules" chapter).

Interrupt Assignment

Table 11-9 Interrupt Assignment

| Interrupt | Function |
|------------------|---|
| NMI | Group interrupt for faults and reset signals |
| IRQ0 | System timer |
| IRQ1 | Reserved for keyboard |
| IRQ2 | Cascading of the 2nd interrupt controller |
| IRQ3 | Assigned to COM2, otherwise free |
| IRQ4 | Assigned to COM1, otherwise free |
| IRQ5 | Assigned to LPT2, otherwise free |
| IRQ6 | Assigned to floppy disk drive, otherwise free |
| IRQ7 | Assigned to LPT1, otherwise free |
| IRQ8 | Real-time clock |
| IRQ9 | Software interrupt, rerouted to IRQ2 |
| IRQ10 | IF 964-DP, otherwise free |
| IRQ11 | CP 1401, otherwise free |
| IRQ12 | Assigned to trackball/mouse |
| IRQ13 | Assigned to numeric coprocessor |
| IRQ14 | Assigned to hard disk drive, otherwise free |
| IRQ15 | Assigned |

M7-400 Expansions

12

Chapter Overview

| Section | Description | Page |
|---------|--|-------|
| 12.1 | Overview | 12-2 |
| 12.2 | EXM 478 Expansion Module; (6ES7 478-2AC00-0AC0) | 12-6 |
| 12.3 | ATM 478 AT Adapter Module; (6ES7 478-2CA00-0AC0) | 12-15 |
| 12.4 | MSM 478 Mass Storage Module; (6ES7 478-2BA00-0AC0) | 12-22 |

12.1 Overview

Introduction

You can expand your automation computer from the M7-400 range by adding expansion modules for interface submodules, short AT modules, and/or the mass storage module. The interface submodules can include the IF 962-COM, IF 962-LPT,

The following expansion modules are available:

- EXM 478 expansion module for up to 3 interface submodules
- ATM 478 AT adapter module for one short AT module
- MSM 478 mass storage module with hard disk and floppy disk drive and an LPT1 printer port.

Expansion Socket

On the right-hand side of a CPU or an M7-400 application module there is a 120-pin socket (AT-ISA bus) for connecting expansions. There is a matching connector for this socket on the left-hand side of the EXM 478, ATM 478, and MSM 478 expansion modules (Figure 12-1).

The EXM 478, ATM 478 and MSM 478 expansion modules have one expansion socket each on the right-hand side so that further expansion modules can be plugged in.

Behavior on the S7-400 Backplane Bus

The expansion modules can be accessed via the relevant programmable module and not via the S7-400 backplane bus.

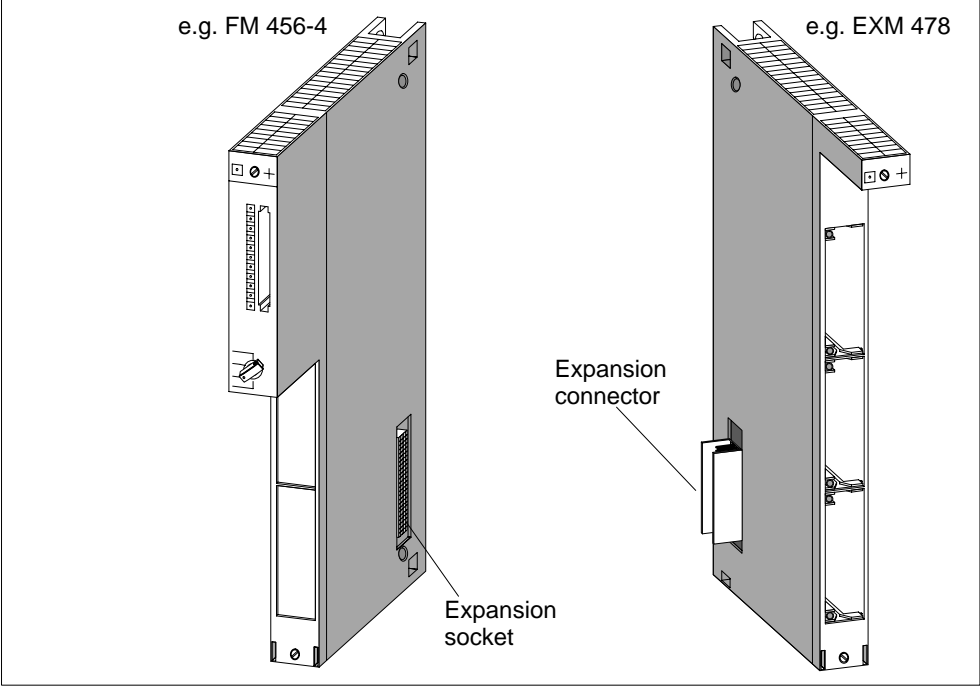

Figure 12-1 Positions of Expansion Socket and Expansion Connector

Maximum Expansion

Figure 12-2 shows the maximum possible expansion using expansion modules for a CPU 486-3, CPU 488-3, or FM 456.

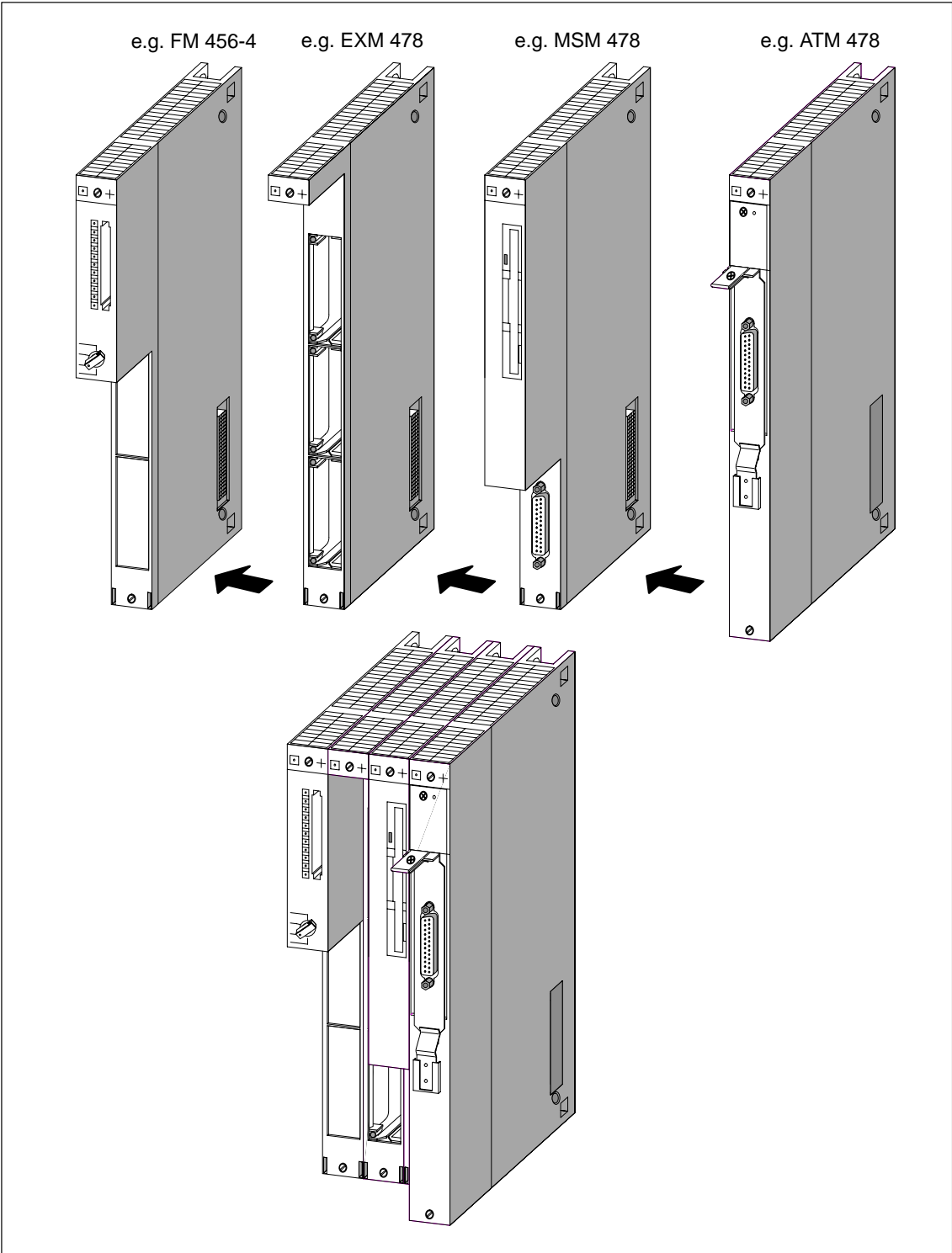

Figure 12-2 Maximum Expansion with Expansion Modules

Permissible Combinations

You can see from the table below which expansions can be connected to the programmable M7-400 modules.

Table 12-1 Expansion Possibilities of the CPU 486-3, CPU 488-3, or FM 456

| Programmable M7-400 Module | Slot | Slot | Slot |
|--|---------|---------|---------|
| Slot n in the Case of Single-Width Modules | n + 1 | n + 2 | n + 3 |
| Slot n and n+1 in the Case of Double-Width Modules | n + 2 | n + 3 | n + 4 |
| CPU 486-3, CPU 488-3, FM 456-4 | – | – | – |
| | EXM 478 | – | – |
| | EXM 478 | EXM 478 | – |
| | EXM 478 | EXM 478 | EXM 478 |
| | EXM 478 | EXM 478 | ATM 478 |
| | EXM 478 | ATM 478 | ATM 478 |
| | EXM 478 | ATM 478 | – |
| | ATM 478 | – | – |
| | ATM 478 | ATM 478 | – |
| | ATM 478 | ATM 478 | ATM 478 |
| | MSM 478 | – | – |
| | EXM 478 | MSM 478 | – |
| | EXM 478 | EXM 478 | MSM 478 |
| | EXM 478 | MSM 478 | ATM 478 |
| | MSM 478 | ATM 478 | ATM 478 |
| MSM 478 | ATM 478 | – | |

Rules for the Combinations

The following rules apply for expansions from left to right after a CPU or application module (slots n + 1, n + 2, n + 3 or n + 2, n + 3, n + 4):

1. Up to 3 EXM 478 expansion modules
2. Max. 1 MSM 478 mass storage module
(that is, always after the CPU 486-3, CPU 488-3, FM 456, or EXM 478)
3. Up to 3 ATM 478 AT adapter modules
(that is, always after the CPU 486-3, CPU 488-3, FM 456, EXM 478, or MSM 478)

In total, a CPU or application module can be expanded with up to three modules.

12.2 EXM 478 Expansion Module; (6ES7 478-2AC00-0AC0)

Characteristics

The EXM 478 expansion module is used to house up to three interface submodules. By installing the relevant interface submodule in this expansion module, such as the IF 962-VGA and IF 962-LPT, you can connect, for example, a VGA monitor, a keyboard, and a printer to your automation computer.

The EXM 478 expansion module has a 120-pin connector on the left-hand side and a 120-pin socket on the right-hand side for connecting a further expansion module or a mass storage module.

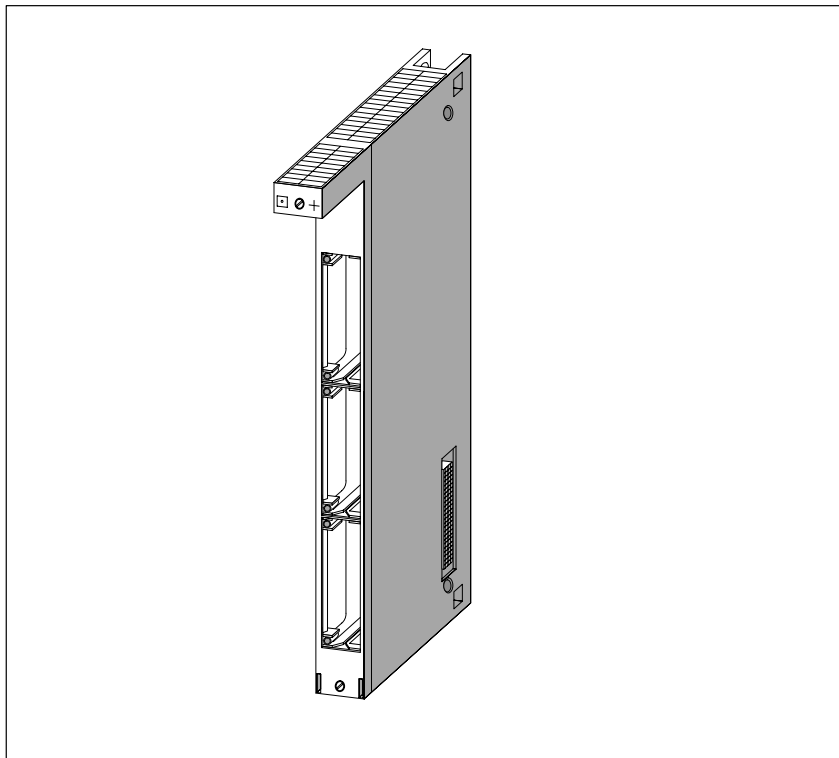

Figure 12-3 EXM 478 Expansion Module

12.2.1 Addressing the EXM 478 Expansion Module

Introduction

In order to be able to program the interface submodules in the EXM 478 expansion module, you must be able to determine their addresses. There are the following addressing methods:

- Addressing in the AT-compatible I/O address area
- Addressing in the M7-400-specific I/O address area

In this section, you will find information on both methods of addressing the interface submodules.

Addressing in the AT-Compatible I/O Address Area

Some of the interface submodules are automatically configured by the BIOS for operation in the AT-compatible I/O address area. This automatic configuration takes place, for example, for:

- The IF 962-VGA interface submodule
- Up to 4 COM ports (COM1 to COM4)
- Up to 3 LPT ports (one LPT port on the MSM 478 and two interface submodules IF 962-LPT)

Further interfaces are configured in the BIOS setup. See the CPU/FM description to learn how to operate the BIOS setup. The description of the interface submodules will show the specific settings possible.

To configure in the BIOS setup, you must know the submodule receptacle numbers of the interface submodule receptacles (slots). You will find this information in Figure 12-4 later in this section.

Addressing in the M7-400-Specific I/O Address Area

All interface submodules can be accessed via M7-400-specific I/O addresses. There is a description of how to determine the I/O address of an interface submodule in the “specific address area” starting from page 12-10.

You require this information to program an interface submodule that is not addressed in the AT-compatible address area.

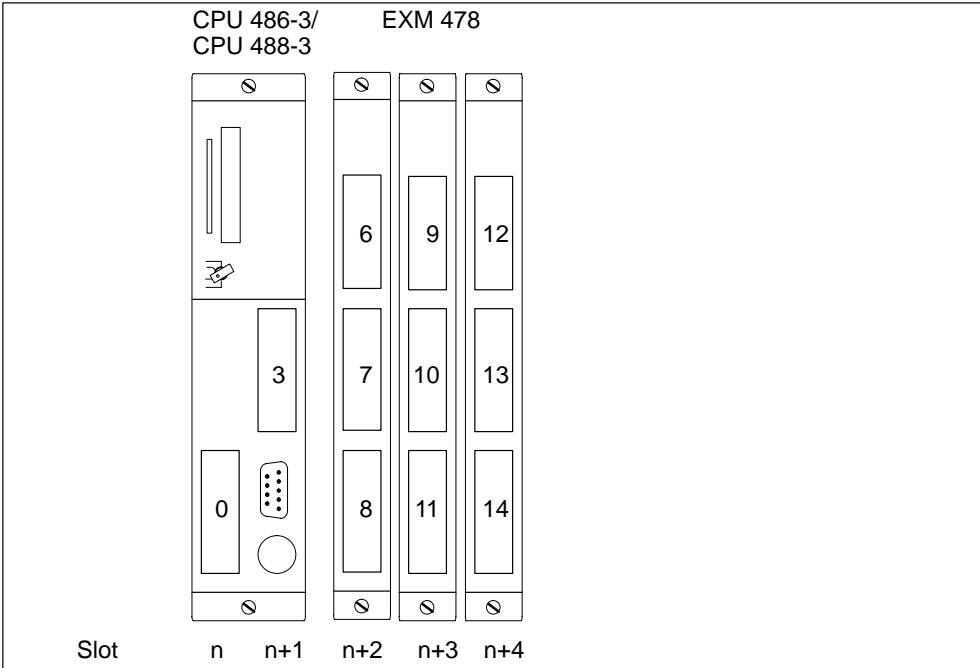

Figure 12-5 Submodule Receptacle Numbers for the CPU 486-3, CPU 488-3, and EXM 478

Division of Addresses in the M7-400-Specific I/O Address Area

The EXM 478 expansion module is operated on the ISA bus of the programmable module. The I/O address area from C000_H (to D2FF_H) in the CPU 486-3, CPU 488-3, or the FM 456 application module is reserved for this purpose. Each expansion module occupies 256 bytes (100_H) in this area. The division of the address area is shown in Figure 12-6 using the FM 456-4 as an example.

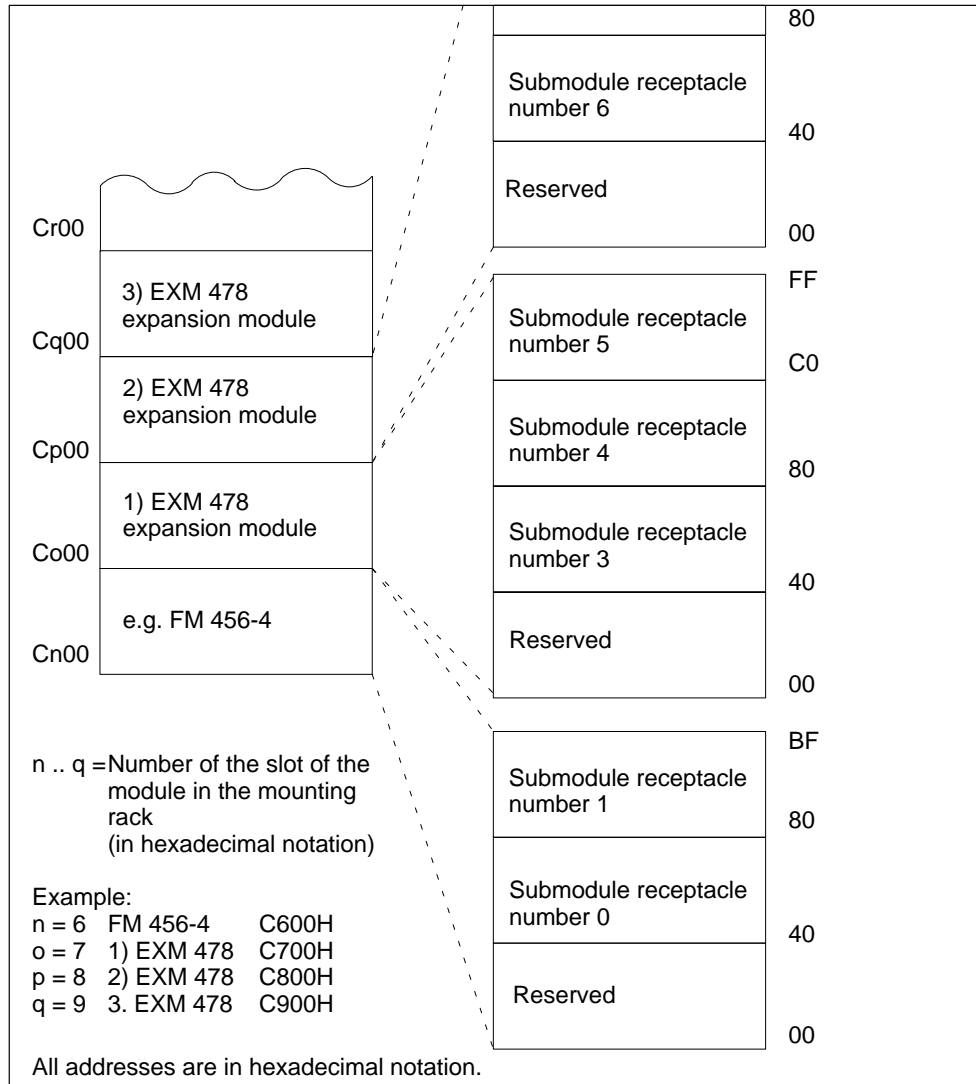

Figure 12-6 Base Addresses of the Expansion Modules and the Interface Submodules

Addresses Within an Expansion Module

Each expansion module occupies 256 bytes (100_H) within the CPU/FM address area. The division of the 256 addresses within an expansion module can be seen from Table 12-2.

Table 12-2 Division of Addresses Within an Expansion Module

| Address | Function/Slot | Remarks |
|------------------------------------|-----------------------|--|
| 00 _H to 3F _H | Reserved | In this address area, the automation computer's BIOS makes basic settings in the expansion module such as assignment of interrupts, etc. |
| 40 _H to 7F _H | Interface submodule x | |
| 80 _H to BF _H | Interface submodule y | |
| C0 _H to FF _H | Interface submodule z | |

Base Addresses of the Interface Submodules

Special characteristics of the interface submodules such as the location of the AT-compatible I/O addresses (IF 962-COM, IF 962-LPT, ...) are set via the base addresses, or the interface submodules are accessed exclusively via these base addresses (IF 961-DIO, IF 961-AIO,...).

The base address for an interface submodule is obtained from the sum of the slot-dependent address of the expansion module and the interface submodule address within the expansion module. You can find the resulting base addresses in Tables 12-3 and 12-4:

Table 12-3 Base Addresses of the Interface Submodules with FM 456-4

| Base Address | Modules | Interface Submodule in Submodule Receptacle ... |
|--|-------------------------------|---|
| Cn40 _H | FM 456-4 Slot n | Number 0 |
| Cn80 _H | | Number 1 |
| Co40 _H | 1st EXM 478 in slot o = n + 1 | Number 3 |
| Co80 _H | | Number 4 |
| CoC0 _H | | Number 5 |
| Cp40 _H | 2nd EXM 478 in slot p = n + 2 | Number 6 |
| Cp80 _H | | Number 7 |
| CpC0 _H | | Number 8 |
| Cq40 _H | 3rd EXM 478 in slot q = n + 3 | Number 9 |
| Cq80 _H | | Number 10 |
| CqC0 _H | | Number 11 |
| n .. q = Number of the module slot in the mounting rack in hexadecimal notation. | | |

Table 12-4 Base Addresses of the Expansion Modules with CPU 486-3, CPU 488-3

| Base Address | Modules | Interface Submodule in Submodule Receptacle ... |
|--|--------------------------------|---|
| Cn40 _H | CPU 486-3, CPU 488-3 Slot n | Number 0 |
| Co40 _H | | Number 3 |
| Cp40 _H | 1st EXM 478 in slot p = n + 2 | Number 6 |
| Cp80 _H | | Number 7 |
| CpC0 _H | | Number 8 |
| Cq40 _H | 2nd EXM 478 in slot q = n + 3 | Number 9 |
| Cq80 _H | | Number 10 |
| CqC0 _H | | Number 11 |
| Cr40 _H | 3rd EXM 478 in slot r = n + 4 | Number 12 |
| Cr80 _H | | Number 13 |
| CrC0 _H | | Number 14 |
| n .. r = Number of the module slot in the mounting rack in hexadecimal notation. | | |

12.2.2 Interrupt Assignments, Signal Switching EXM 478

Introduction

Up to three interrupts per interface submodule are permitted in an EXM 478 expansion module. The various possible methods of interrupt assignment or interrupt operation are described below.

Interrupt Assignment

When configuring the interface submodules in the BIOS setup, you can assign ISA interrupts to the three interrupts of an interface submodule (IRQa, IRQb, IRQc). For this purpose, enter the ISA interrupt provided in the relevant screen form.

If you enter the value “F0_H” instead of the ISA interrupt, this interrupt is processed via a shared interrupt. See below for details.

Shared Interrupt

Since the number of interrupts is limited due to AT-compatibility, it is possible to assign several individual interrupts of the interface submodules to a shared interrupt in the EXM 478 expansion modules. The shared interrupt is shared by all interface submodule interrupts within an expansion module where the interrupt assignment “F0_H” has been entered.

The shared interrupt is assigned to the ISA interrupt during configuration of the interface submodule in the BIOS setup.

Signal Switching

In an EXM 478 expansion module, two interface submodule signals can be switched to another (signal switching). This signal switching is done during configuration of the interface submodule in the BIOS setup.

Refer to the interface submodule description to find out if an interface submodule requires signals from a further interface submodule, that is, if signal switching is necessary.

Note

You will find a detailed description of the BIOS setup in the M7-400 application module or CPU description.

12.2.3 Technical Specifications of the EXM 478 Expansion Module

Technical Specifications of the EXM 478

The table below contains the technical specifications of the EXM 478 expansion module:

| EXM 478 | |
|--|----------------|
| 6ES7 478-2AC00-0AC0 | |
| Performance Features | |
| Number of connectable interface modules | 3 |
| Connection of expansion modules | Yes |
| Technical Specifications | |
| Supply voltage | 5 VDC |
| Current consumption (without interface submodules) | 0.2 A |
| Power losses (without interface submodules) | 0.5 W |
| Permissible power losses (with 3 interface submodules) | |
| • Without forced ventilation | max. 10 W |
| • With forced ventilation | max. 12 W |
| Dimensions | |
| W x H x D (mm) | 25 x 290 x 210 |
| Weight | 0.65 kg |

Note

The sum of the power losses of the EXM 478 expansion module and the interface submodules it contains must not exceed the maximum permissible power losses.

12.3 ATM 478 AT Adapter Module; (6ES7 478-2CA00-0AC0)

Characteristics

The ATM 478 AT adapter module is used to accommodate a short AT module (card).

The ATM 478 AT adapter module has a 120-pin connector on the left-hand side and a 120-pin socket on the right-hand side for connecting a further expansion module or a mass storage module.

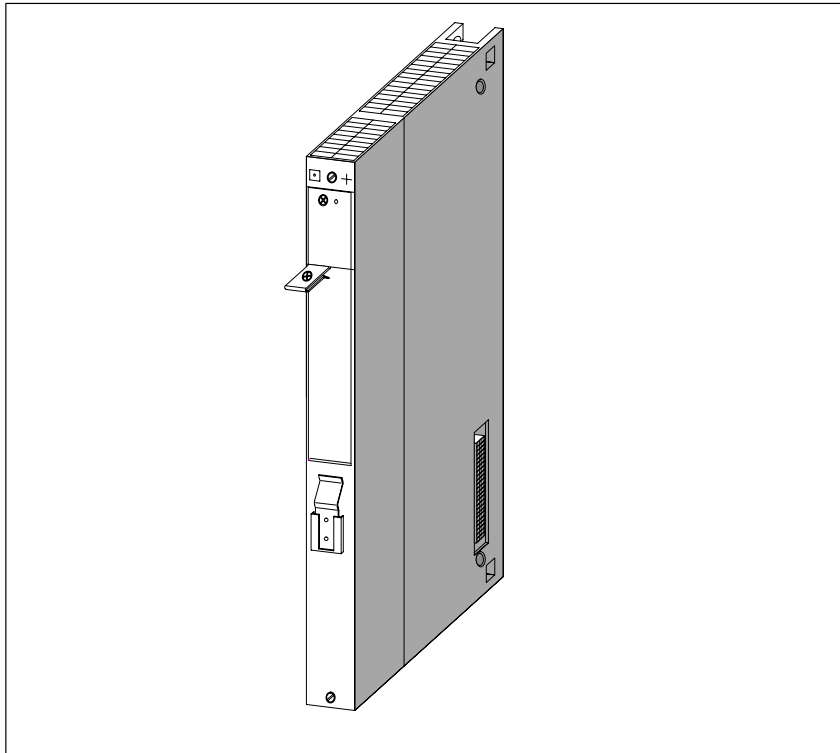

Figure 12-7 ATM 478 AT Adapter Module

12.3.1 Pin Assignments of the AT Module

Pin Assignments

The ATM 478 AT adapter module has a 98-pin standard direct connector for short AT modules (see Figure 12-8).

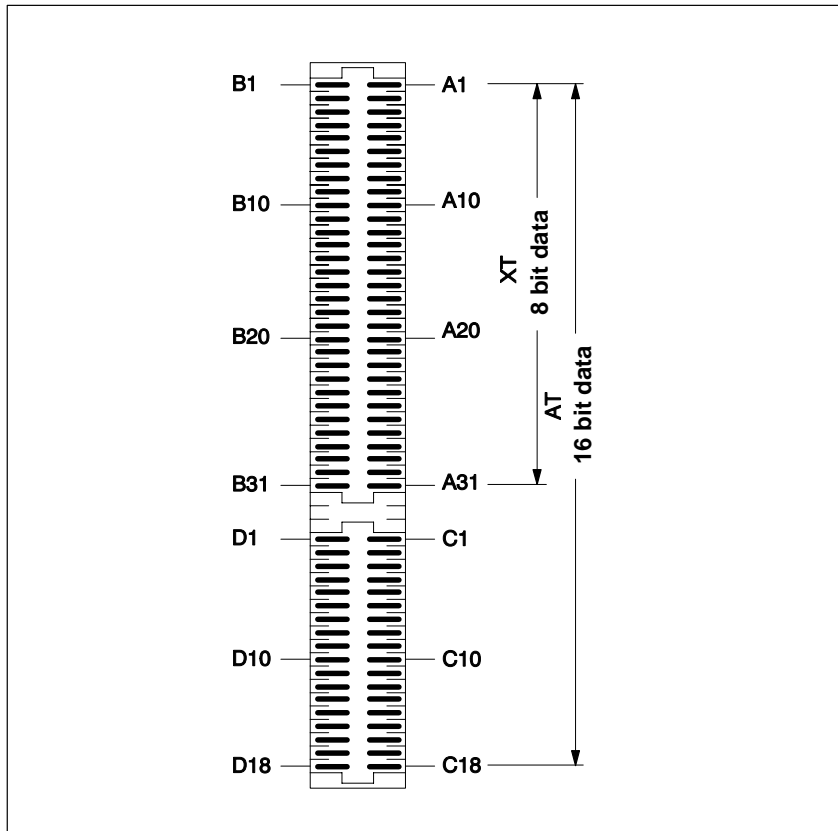

Figure 12-8 ATM 478 AT Adapter Module, 98-Pin Standard Direct Connector

See the following table for the pin assignments of the 98-pin standard direct connector.

Table 12-5 Pin Assignments of the 98-Pin Standard Direct Connector (ATConnector)

| Pin | Signal Name | Pin | Signal Name |
|------------|-------------|-----|-------------|
| XT Signals | | | |
| B1 | GND | A1 | I/OCHCK_N |
| B2 | RESET DRV | A2 | SD7 |
| B3 | P5V | A3 | SD6 |
| B4 | IRQ9 | A4 | SD5 |
| B5 | N5V | A5 | SD4 |
| B6 | DRQ2 | A6 | SD3 |
| B7 | N12V | A7 | SD2 |
| B8 | 0WS | A8 | SD1 |
| B9 | P12V | A9 | SD0 |
| B10 | GND | A10 | I/OCHRDY_N |
| B11 | SMEMW_N | A11 | AEN |
| B12 | SMEMR_N | A12 | SA19 |
| B13 | I/OW_N | A13 | SA18 |
| B14 | I/OR_N | A14 | SA17 |
| B15 | DACK3_N | A15 | SA16 |
| B16 | DRQ3 | A16 | SA15 |
| B17 | DACK1_N | A17 | SA14 |
| B18 | DRQ1 | A18 | SA13 |
| B19 | REFRESH | A19 | SA12 |
| B20 | SYSCLK | A20 | SA11 |
| B21 | IRQ7 | A21 | SA10 |
| B22 | IRQ6 | A22 | SA9 |
| B23 | IRQ5 | A23 | SA8 |
| B24 | IRQ4 | A24 | SA7 |
| B25 | IRQ3 | A25 | SA6 |
| B26 | DACK2_N | A26 | SA5 |
| B27 | T/C | A27 | SA4 |
| B28 | BALE | A28 | SA3 |
| B29 | P5V | A29 | SA2 |
| B30 | OSC | A30 | SA1 |
| B31 | GND | A31 | SA0 |

Table 12-5 Pin Assignments of the 98-Pin Standard Direct Connector (ATConnector), continued

| Pin | Signal Name | Pin | Signal Name |
|--------------|-------------|-----|-------------|
| AT Expansion | | | |
| D1 | MEMCS_16_N | C1 | SBHE_N |
| D2 | I/OCS16_N | C2 | LA23 |
| D3 | IRQ10 | C3 | LA22 |
| D4 | IRQ11 | C4 | LA21 |
| D5 | IRQ12 | C5 | LA20 |
| D6 | IRQ15 | C6 | LA19 |
| D7 | IRQ14 | C7 | LA18 |
| D8 | DACK0_N | C8 | LA17 |
| D9 | DRQ0 | C9 | MEMR_N |
| D10 | DACK5_N | C10 | MEMW_N |
| D11 | DRQ5 | C11 | SD8 |
| D12 | DACK6_N | C12 | SD9 |
| D13 | DRQ6 | C13 | SD10 |
| D14 | DACK7_N | C14 | SD11 |
| D15 | DRQ7 | C15 | SD12 |
| D16 | P5V | C16 | SD13 |
| D17 | MASTER_N | C17 | SD14 |
| D18 | GND | C18 | SD15 |

12.3.2 Technical Specifications of the ATM 478 AT Adapter Module

Technical Specifications of the ATM 478

The table below contains the technical specifications of the ATM 478 AT adapter module:

| ATM 478 | | Supply of the AT Module | |
|---|--|---|--------------|
| 6ES7 478-2CA00-0AC0 | | Supply voltage | max. current |
| Performance Features | | + 5 V (4.75 V to 5.25 V) | 4 A |
| Number of connectable AT modules (short) | 1 | - 5 V (- 4.4 V to - 5.3 V) | 70 mA |
| Connection of expansion modules | Yes | + 12 V (11.7 V to 12.3 V) | 500 mA |
| Technical Specifications | | - 12 V (- 10.9 V to - 13.5 V) | 100 mA |
| Supply voltage | 5 VDC | The supply voltages -5 V, +12 V, and -12 V are monitored. In the event of a fault, the "INTF" LED on the CPU or application module lights up. | |
| Current consumption (without AT module) | 0.12 A | | |
| Current consumption of the AT module | See calculation of current consumption | | |
| Power losses (without AT module) | 0.6 W | | |
| Permissible power losses (with AT module) | | | |
| • Without forced ventilation | max. 10 W | | |
| • With forced ventilation | max. 12 W | | |
| Dimensions | | | |
| W x H x D (mm) | 25 x 290 x 230 | | |
| Weight (without AT module) | 0.74 kg | | |

Calculation of Power Consumption

You can calculate the power consumption of the short AT module using the following formula:

$$I_{(\text{AT module})} = I_{(-5\text{ V})} \times 1.3 + (I_{(+12\text{ V})} + I_{(-12\text{ V})}) \times 3.12$$

Example of Power Loss Calculation

The following table contains a calculation example for the total power losses for an AT adapter module with an AT module.

Table 12-6 Calculation Example for Total Power Losses of an ATM 478 with AT Module

| Remark | Voltage | Current Consumption | Power Losses |
|--|--|---------------------|--------------|
| Power losses of the AT module | + 5 V | 0.8 A | 4 W |
| | + 12 V | 0.1 A | 1.2 W |
| | - 12 V | 0.05 A | 0.6 W |
| | - 5 V | – | – |
| Power losses of the internal power supply of the ATM 478 for supplying the AT module | $(P_{+12V} + P_{-12V} + P_{-5V}) \times 0.3$ $(1.2 + 0.6 + 0) \times 0.3 \text{ W}$ | | 0.54 W |
| Power losses of the ATM 478 AT adapter module | | | 0.6 W |
| Total power losses of the ATM 478 adapter module with AT module | | | 6.94 W |

In this example, the power losses are 6.94 W. The ATM 478 AT adapter module can be operated without forced ventilation.

Permissible Dimensions of AT Modules

The following illustration shows you the maximum and minimum dimensions in millimeters that AT modules must meet for the ATM 478 AT adapter module. If these dimensions are not conformed to, proper installation in the ATM 478 AT adapter module is no longer possible.

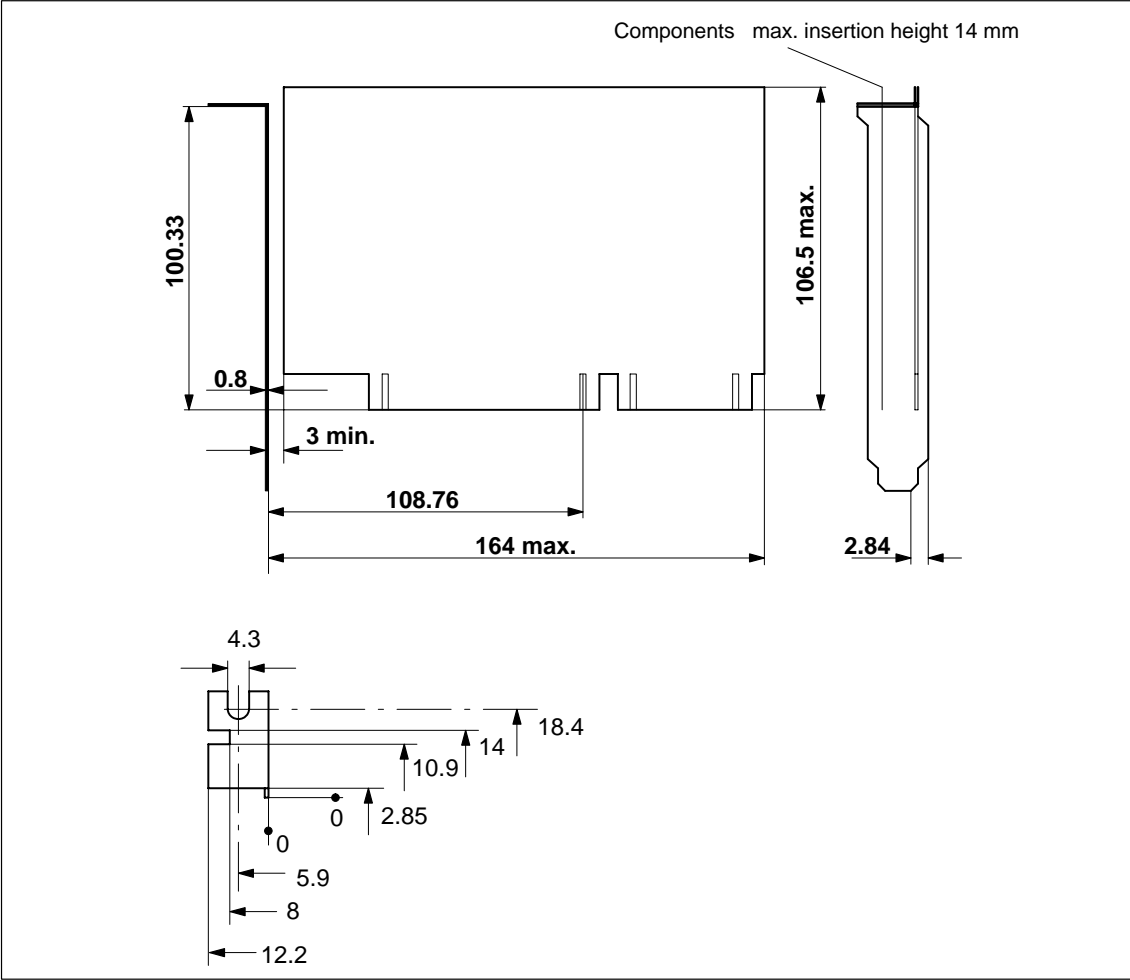

Figure 12-9 Dimension Specifications for AT Modules to be Installed in an ATM 478

12.4 MSM 478 Mass Storage Module; (6ES7 478-2BA00-0AC0)

Characteristics

The MSM 478 mass storage module is used for storing programs and larger quantities of data. It also has an AT-compatible parallel port (LPT).

The MSM 478 mass storage module has the following function units:

- One 3.5"/1.44-Mbyte floppy disk drive
- One hard disk drive with a capacity of $\geq 516 \times 10^6$ bytes
- One AT-compatible parallel port LPT1

The MSM 478 mass storage module has a 120-pin connector on the left-hand side and a 120-pin socket on the right-hand side for connecting further expansion modules.

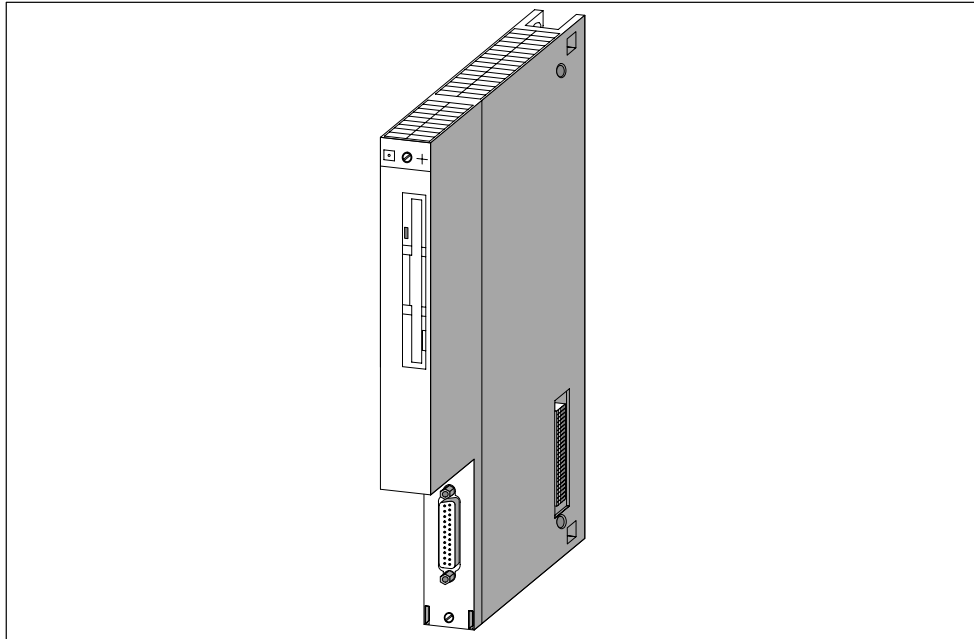

Figure 12-10 MSM 478 Mass Storage Module

System Integration BIOS Setup

So that the BIOS of your CPU 486-3, CPU 488-3, or your FM 456 can correctly access the diskette and the hard disk, you must make some settings in the BIOS setup of your CPU/FM.

To learn how to make these settings, see the “BIOS setup” section of the module description.

12.4.1 LPT1 Parallel Port

Characteristics

The MSM 478 mass storage module has an AT-compatible parallel port (LPT) for connecting a printer with Centronics interface. The parallel port can also be used as a bi-directional data interface. There is a 25-pin sub D socket connector on the frontside of the submodule for plugging in the connecting cable.

This parallel port is always configured by the BIOS as LPT1 regardless of the slot occupied by the MSM 478 mass storage module.

Addressing

I/O address of the parallel port (LPT): **03BC_H** (to 03BE_H)

Device name: **LPT1**

Interrupt Request

The parallel port (LPT) supplies the interrupt request IRQ7.

Pin Assignment of the Parallel Port

There is a 25-pin sub D socket connector on the frontside of the submodule for plugging in the connecting cable. See Table 12-7 for the pin assignments.

Cable Length

The cable length on the LPT1 parallel port should not exceed approximately 3 m.

Table 12-7 MSM 478 Parallel Port, Socket X1 (25-Pin Sub D Socket)

| Pin | Meaning | Direction |
|-----|------------|--------------|
| 1 | /STROBE | Input/output |
| 2 | Data 0 | Input/output |
| 3 | Data 1 | Input/output |
| 4 | Data 2 | Input/output |
| 5 | Data 3 | Input/output |
| 6 | Data 4 | Input/output |
| 7 | Data 5 | Input/output |
| 8 | Data 6 | Input/output |
| 9 | Data 7 | Input/output |
| 10 | /ACK | Input |
| 11 | BUSY | Input |
| 12 | PE | Input |
| 13 | SLCT | Input |
| 14 | /AUTO FEED | Output |
| 15 | /ERROR | Input |
| 16 | /RESET | Output |
| 17 | /SLCT IN | Output |
| 18 | GND | – |
| 19 | GND | – |
| 20 | GND | – |
| 21 | GND | – |
| 22 | GND | – |
| 23 | GND | – |
| 24 | GND | – |
| 25 | GND | – |

Note

Operational ground (GND signal) at the COMa or COMb ports is referenced to internal ground.

Suitable measures may be required on the process side to avoid ground loops.

12.4.2 Technical Specifications of the MSM 478 Mass Storage Module

Technical Specifications of the MSM 478

The table below contains the technical specifications of the MSM mass storage module: 478

| With Mass Storage Module MSM 478 | | Ambient Operating Conditions | |
|----------------------------------|-------------------------------|---|--|
| 6ES7 478-2AB00-0AC0 | | | |
| Performance Features | | | |
| Diskette | 3.5", 1.44 Mbytes | Temperature: Without forced ventilation | from 0 to 40 °C |
| Hard disk | ≥ 516 x 10 ⁶ bytes | With forced ventilation without diskette | from 0 to 55 °C |
| Parallel port | 1, LPT1 | with diskette | from 0 to 40 °C |
| Connection of expansion modules | Yes | Temperature change: | max. 10 K/h |
| Technical Specifications | | Relative humidity: | 8% to 80% at 25 °C, no condensation |
| Supply voltage | 5 VDC | Height (in relation to sea level) | -50 m to 2,000 m |
| Current consumption | 1 A | Mechanical vibrations (measured at the drive) | |
| Power losses | 5 W | 10 ≤ f ≤ 58 Hz | 0,035 mm, constant amplitude |
| Dimensions W x H x D (mm) | 25 x 290 x 210 | 58 ≤ f ≤ 500 Hz | 0.1 g, constant acceleration |
| Weight | 1.08 kg | Shocks: (measured at the drive) | Semisinusoidal: 5 g, 11 ms |
| | | Environmental Conditions for Storage/Transport | |
| | | Temperature: | from -10 to 60 °C |
| | | Temperature change: | max. 20 K/h |
| | | Relative humidity: | 8% to 80% at 25 °C, no condensation |
| | | Mechanical vibrations | |
| | | 5 ≤ f ≤ 9 Hz | 3.5 mm amplitude |
| | | 9 ≤ f ≤ 500 Hz | 1 g acceleration |
| | | Shocks: | Semisinusoidal: 50 g, 11 ms |

Note

The ambient conditions specified are limit values determined by the hard disk drive. The values must not be exceeded on the hard disk drive.

Interface Submodules

Chapter Overview

| Section | Description | Page |
|---------|--|-------|
| 13.1 | Interface Submodules Overview | 13-2 |
| 13.2 | Submodule IDs and Insertion Rules | 13-4 |
| 13.3 | IF 962-VGA Interface Submodule for M7-300/400; (6ES7962-1BA00-0AC0) | 13-5 |
| 13.4 | IF 962-COM Interface Submodule for M7-300/400; (6ES7962-3AA00-0AC0) | 13-10 |
| 13.5 | IF 962-LPT Interface Submodule for M7-300/400; (6ES7962-4AA00-0AC0) | 13-16 |
| 13.6 | IF 961-DIO Interface Submodule for M7-300/400; (6ES7961-1AA00-0AC0) | 13-23 |
| 13.7 | IF 961-AIO Interface Submodule for M7-300/400; (6ES7961-2AA00-0AC0) | 13-33 |
| 13.8 | IF 961-CT1 Interface Submodule for M7-300/400; (6ES7961-3AA00-0AC0) | 13-56 |
| 13.9 | IF 964-DP Interface Submodule for S7-400 and M7-400 | 13-61 |

13.1 Interface Submodules Overview

Introduction

The interface submodules are designed for use in the M7-300 and M7-400 automation computers. They can be operated in the M7-400 programmable modules and in the EXM 378/EXM 478 expansion modules. The interface submodules are controlled via the ISA bus.

The interface submodules are labeled on the front plate and so can be identified even when installed.

Handling

Interface submodules and their front connectors must only be plugged in or removed when the power is switched off. Avoid confusing front connectors since this can destroy the interface submodules or the connected devices.

ESD Guidelines

The interface submodules are not enclosed on the underside. For this reason, you must observe ESD guidelines when handling these modules.

Slots/Submodule Receptacle Numbers

To link the interface submodules into your system (for example, BIOS Setup), you require the submodule receptacle numbers. See the descriptions of the M7-400 programmable modules or the M7-300/400 expansion modules for the numbering of the individual submodule receptacles.

Addressing in the M7-300/400 - Reserved I/O Address Area

In the M7-300/400 automation computers, the I/O address area C000_H is reserved for addressing the interface submodules.

The base address at which an interface submodule can be addressed depends on the submodule receptacle of the M7-400 programmable module or the M7-300/400 expansion module containing the interface submodule. You can find the submodule-receptacle-dependent base address of the interface submodule in the description of the M7-400 programmable module or the M7-300/400 expansion module.

The sections below describe the registers and their meanings as well as the associated offset addresses for the individual interface submodules.

The resulting I/O address is the sum of the base address and the offset address.

Submodule ID

Each interface submodule has a submodule ID stored in read-only memory. This information is required in the BIOS Setup.

Interrupt Assignments

When configuring the interface submodules in the BIOS setup, you can assign ISA interrupts to the three interrupts of an interface submodule (IRQa, IRQb, IRQc). For this purpose, enter the ISA interrupt provided in the relevant screen form. See the table below for the format for entering the interrupt.

Table 13-1 Format of the Interrupt Entry in the BIOS Setup of the Interface Submodule

| Bit 7 | Bit 6 | Bit 5 | Bit 4 | Bit 3 | Bit 2 | Bit 1 | Bit 0 |
|-------|-------|-------|-------|----------------------|-------|-------|-------|
| 1 | 1 | 1 | 0 | ISA interrupt number | | | |

If you enter the value “F0_H” instead of the ISA interrupt (“EX_H”), this interrupt is processed via a shared interrupt.

Shared Interrupt

Since the number of interrupts is limited due to AT-compatibility, it is possible to assign several individual interrupts of the interface submodules to a shared interrupt. The shared interrupt is shared by all interface submodule interrupts within an expansion module where the interrupt assignment “F0_H” has been entered.

The shared interrupt is assigned to the ISA interrupt during configuration of the interface submodule in the BIOS setup.

Signal Switching

In an EXM 478 expansion module, two interface submodule signals can be switched to another (signal switching). This signal switching is done during configuration of the interface submodule in the BIOS setup.

Refer to the interface submodule description to find out if an interface submodule requires signals from a further interface submodule, that is, if signal switching is necessary.

13.2 Submodule IDs and Insertion Rules

Submodule IDs

The following table contains an overview of the submodule IDs for the interface submodules.

Table 13-2 Overview of the Submodule IDs for the Interface Submodules

| Interface Submodule | Submodule ID |
|---------------------|-----------------|
| IF 961-AIO | 01 _H |
| IF 961-CT1 | 03 _H |
| IF 961-DIO | 02 _H |
| IF 962-COM | 41 _H |
| IF 962-LPT | 44 _H |
| IF 962-VGA | 81 _H |
| IF 964-DP | 8C _H |

Insertion Rules

The interface submodules cannot be operated in all submodule receptacles. The following table shows the insertion rules for those interface submodules that cannot be used in all receptacles:

Table 13-3 Insertion Rules for Interface Submodules that Cannot be Used in All Receptacles

| Interface Submodule | Submodule Receptacle Numbers in the Following Modules | | | | | | | | | |
|-----------------------------------|---|---|-----------|---|---|----------|---|-------------------------|-----------------|---------|
| | EXM 378-2 | | EXM 378-3 | | | FM 456-4 | | CPU 486-3/ CPU 488-3 | | EXM 478 |
| | 1 | 2 | 3 | 4 | 5 | 0 | 1 | 0 | 3 | all |
| IF 962-VGA 6ES7 962-1BA00-0AC0 | • | • | – | • | • | • | • | • | • | • |
| IF 964-DP 6ES7 964-2AA00-0AB0 | • | • | – | • | • | • | • | • | • ^{*)} | • |

^{*)} Preferred slot for IF 964-DP if only one submodule is inserted, see Table 11-8 on page 11-40.

13.3 IF 962-VGA Interface Submodule for M7-300/400; (6ES7962-1BA00-0AC0)

Characteristics

The IF 962-VGA interface submodule is used to connect a keyboard and a VGA screen. The interfaces to the keyboard and the screen are AT-compatible.

As an alternative to a “normal” AT keyboard, a keyboard with an integrated trackball can be connected (for example, the PG 740 keyboard).

The IF 962-VGA interface submodule is designed for the local area and the distance to the I/O devices should not exceed approximately 2.5 m.

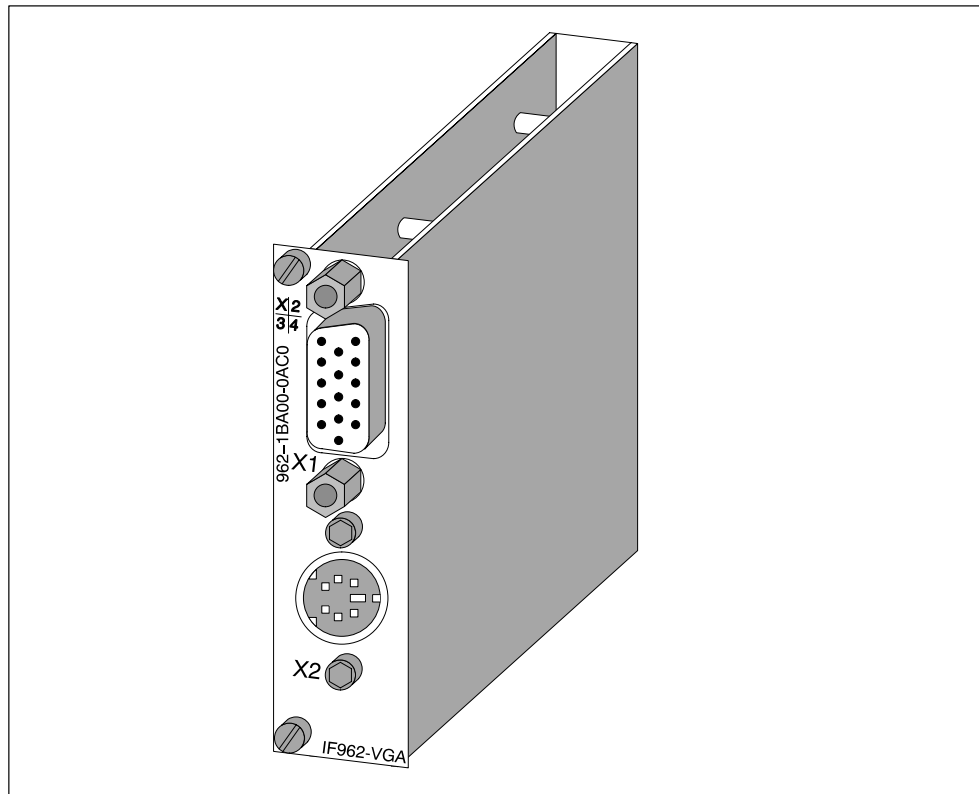

Figure 13-1 IF 962-VGA Interface Submodule

Note

You can operate a maximum of one keyboard/graphics submodule on one programmable module (CPU or FM).

13.3.1 Pin Assignments

Socket X1 VGA Screen Connection

Table 13-4 Socket X1, VGA Screen Connection IF 962-VGA (15-Pin High-Density Sub D Socket Connector)

| Pin | Meaning |
|-----|------------------|
| 1 | Analog red |
| 2 | Analog green |
| 3 | Analog blue |
| 4 | |
| 5 | Signal GND |
| 6 | Analog GND red |
| 7 | Analog GND green |
| 8 | Analog GND blue |
| 9 | |
| 10 | Signal GND |
| 11 | |
| 12 | |
| 13 | Horizontal sync |
| 14 | Vertical sync |
| 15 | |

Socket X2 Keyboard Connection

Table 13-5 X2 Socket, Keyboard Plug Connection IF 961-VGA (6-Pin Mini DIN Socket Connector)

| Pin | Meaning | Direction |
|-----|----------------|--------------|
| 1 | Keyboard data | Input/output |
| 2 | Mouse data | Input/output |
| 3 | Signal GND | – |
| 4 | 5 VDC | – |
| 5 | Keyboard clock | Input/output |
| 6 | Mouse clock | Input/output |

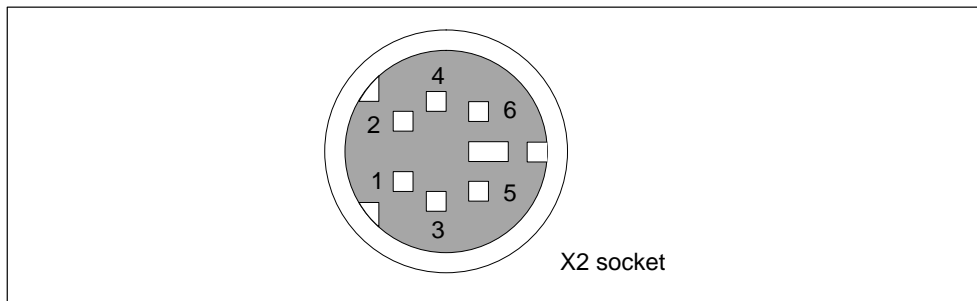

Figure 13-2 X2 Socket, Keyboard Plug Connection IF 961-VGA (6-Pin Mini DIN Socket Connector)

13.3.2 Addressing, Interrupts, and Submodule ID

Addressing

Addressing corresponds to the AT standard.

The following addresses are occupied by the IF 962-VGA interface submodule:

Memory addresses: A0000_H to C7FFF_H

I/O addresses: 060_H to 06F_H, 3B0_H to 3BB_H, 3BF_H to 3DF_H

Interrupt Request

The interface submodule supplies the following interrupts:

- IRQ a: Keyboard interrupt
- IRQ b: Mouse interrupt (trackball)
- IRQ c: VGA interrupt

The BIOS routes these interrupts to ISA interrupts in accordance with Table 13-6.

Table 13-6 Interrupt Assignments of the IF 962-VGA Interface Submodule

| Interrupt Source of the Interface Submodule | | ISA Interrupt |
|---|-------|------------------------------|
| Keyboard | IRQ a | IRQ 1 |
| Mouse (track ball) | IRQ b | IRQ 12 |
| VGA | IRQ c | Can be set in the BIOS setup |

Submodule ID

The IF 962-VGA interface submodule has the submodule ID **81_H**.

13.3.3 Technical Specifications

Technical Specifications

The IF 962-LPT interface submodule receives its supply voltage from the M7-400 programmable modules or from the M7-300/400 expansion modules. The current consumption given in the technical specifications is the consumption required for dimensioning the power supply, that is, the current consumption is referenced to 24 V in the M7-300 and to 5 V in the M7-400.

| 6ES7962-1BA00-0AC0 | |
|--|--|
| Technical Specifications | |
| Supply voltage | Supplied from the M7-400 programmable modules or from the M7-300/400 expansion modules |
| Current consumption in the M7-300 (for dimensioning the 24 V current supply) | 0.21 A |
| Current consumption in the M7-400 (for dimensioning the 5 V current supply) | 0.6 A |
| VGA controller | WD90C24 |
| Video controller | 1 Mbytes |
| Submodule ID | 81 _H |
| Power losses | 2.5 W |
| Dimensions W x H x D (mm) | 18.2 x 67 x 97 |
| Weight | 0.085 kg |

Operating Modes

The WD90C24 VGA controller is used on the IF 962-VGA interface submodule. Table 13-7 shows you the video modes supported by the BIOS of the IF 962-VGA interface submodule.

Table 13-7 Video Modes of the IF 962-VGA Interface Submodule

| Mode (HEX) | Text / Graphics | Monochrome/ Color | Resolution (Columns x Lines) | Number of colours | Character Size | Horizontal Frequency (kHz) | Vertical Frequency (Hz) |
|------------|-----------------|-------------------|------------------------------|-------------------|----------------|----------------------------|-------------------------|
| 0.1 | Text | Color | 320 x 200 | 16 | 8 x 8 | 31.5 | 70 |
| 0.1 | Text | Color | 320 x 350 | 16 | 8 x 14 | 31.5 | 70 |
| 0.1 | Text | Color | 360 x 400 | 16 | 9 x 16 | 31.3 | 70 |
| 2.3 | Text | Color | 640 x 200 | 16 | 8 x 8 | 31.5 | 70 |
| 2.3 | Text | Color | 640 x 350 | 16 | 8 x 14 | 31.5 | 70 |
| 2.3 | Text | Color | 720 x 400 | 16 | 9 x 16 | 31.3 | 70 |
| 4.5 | Graphics | Color | 320 x 400 | 4 | 8 x 8 | 31.5 | 70 |
| 6 | Graphics | Monochr. | 320 x 200 | 2 | 8 x 8 | 31.5 | 70 |
| 7 | Text | Monochr. | 720 x 350 | 2 | 9 x 14 | 31.3 | 70 |
| 0D | Graphics | Color | 320 x 200 | 16 | 8 x 8 | 31.5 | 70 |
| 0E | Graphics | Color | 640 x 200 | 16 | 8 x 8 | 31.5 | 70 |
| 0F | Graphics | Monochr. | 640 x 350 | 2 | 8 x 14 | 31.5 | 70 |
| 10 | Graphics | Color | 640 x 350 | 16 | 8 x 14 | 31.5 | 70 |
| 11 | Graphics | Monochr. | 640 x 480 | 2 | 8 x 16 | 31.5 | 60 |
| 12 | Graphics | Color | 640 x 480 | 16 | 8 x 16 | 31.5 | 60 |
| 13 | Graphics | Color | 320 x 200 | 256 | 8 x 8 | 31.5 | 70 |
| 54 | Text | Color | 1056 x 344 | 16 | 9 x 9 | 31.1 | 70 |
| 55 | Text | Color | 1056 x 400 | 16 | 8 x 16 | 31.1 | 70 |
| 5F | Graphics | Color | 640 x 480 | 256 | 8 x 16 | 31.5 | 60 |
| 58/6A | Graphics | Color | 800 x 600 | 16 | 8 x 8 | 35.1 | 56 |
| 58/6A | Graphics | Color | 800 x 600 | 16 | 8 x 8 | 37.8 | 60 |
| 58/6A | Graphics | Color | 800 x 600 | 16 | 8 x 8 | 47.7 | 72 |
| 5C | Graphics | Color | 800 x 600 | 256 | 8 x 8 | 35.1 | 56 |
| 5C | Graphics | Color | 800 x 600 | 256 | 8 x 8 | 37.8 | 60 |
| 5C | Graphics | Color | 800 x 600 | 256 | 8 x 8 | 47.7 | 72 |
| 5D | Graphics | Color | 1024 x 768 | 16 | 8 x 16 | 35.6 | 87 ¹⁾ |
| 5D | Graphics | Color | 1024 x 768 | 16 | 8 x 16 | 48.4 | 60 |
| 60 | Graphics | Color | 1024 x 768 | 256 | 8 x 16 | 35.6 | 87 ¹⁾ |
| 60 | Graphics | Color | 1024 x 768 | 256 | 8 x 16 | 48.4 | 60 |

¹⁾ Interlaced mode

13.4 IF 962-COM Interface Submodule for M7-300/400; (6ES7962-3AA00-0AC0)

Characteristics

The IF 962-COM interface submodule is used to connect devices with a serial port. It contains two serial AT-compatible ports (COMa, COMb).

Up to four COM ports can be accessed on AT I/O addresses in one programmable module using standard PC drivers. This also includes COM ports located on the programmable module itself and those located on expansions. The IF 962-LPT interface submodules can be operated in the AT-compatible address area and, if special drivers are used, also in the M7-300/400-reserved address area.

Connector X1 corresponds to the COMa port, connector X2 to the COMb port. The signal levels are defined in accordance with RS232C.

The cable length on the IF 962-COM interface submodule should not exceed approximately 10 m.

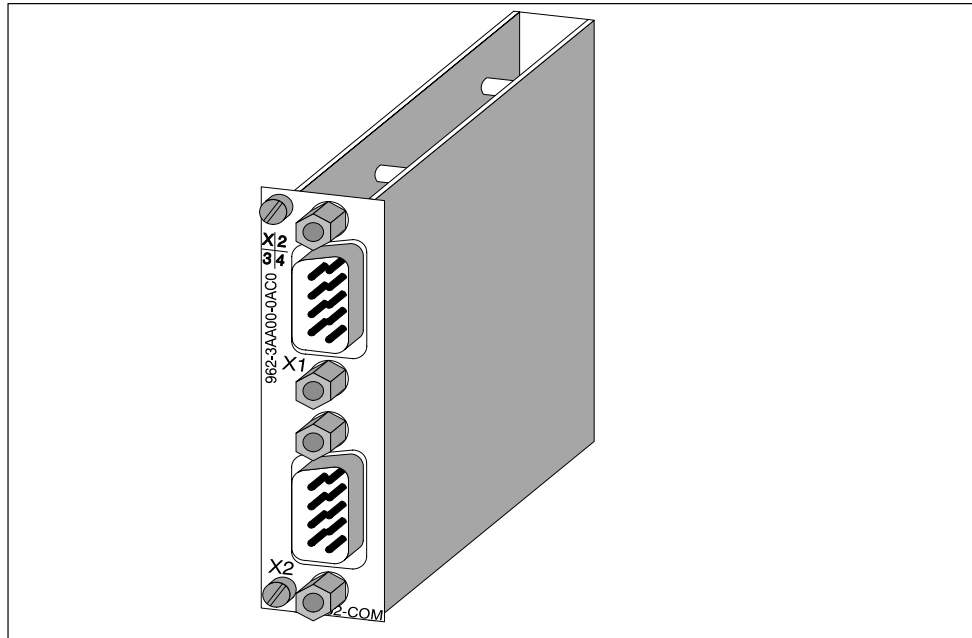

Figure 13-3 IF 962-COM Interface Submodule

What Can be Connected to the Ports?

All devices with an RS232 interface such as:

Printers, modems, terminals, etc.

13.4.1 Pin Assignments

Socket X1, X2 COMa, COMb

Table 13-8 Socket X1, X2 IF 962-COM (9-Pin Sub D Plug Connector)

| | | | |
|---|------------|--|--------|
| 1 | DCD | Receive signal level | Input |
| 2 | RxD | Receive data | Input |
| 3 | TxD | Transmitted data | Output |
| 4 | DTR | Data terminal ready | Output |
| 5 | Signal GND | Operational ground (GND _{int}) | – |
| 6 | DSR | Data set ready | Input |
| 7 | RTS | Request to send | Output |
| 8 | CTS | Clear to send | Input |
| 9 | RI | Ring indicator (incoming call) | Input |

Note

Operational ground (signal GND) at the COMa or COMb ports is referenced to internal ground.

Suitable measures may be required on the process side to avoid ground loops.

13.4.2 Addressing and Interrupts

Addressing

The IF 962-COM interface submodule can be addressed in the following two ways:

- In the AT-compatible I/O address area
- In the M7-300/400-reserved I/O address area (from C000_H).

Addressing in the AT-Compatible I/O Address Area

The COM ports can be operated in the AT-compatible I/O address area. The settings are made in the BIOS Setup. You can see the addresses that can be set in the BIOS Setup from the following table.

Table 13-9 Addressing the COM Ports in the AT-Compatible Address Area

| Name | I/O Address | Remarks |
|--|--|--|
| *) | 03F8 _H to 03FF _H | Automatically configured by the BIOS and can be set in the BIOS setup. |
| | 02F8 _H to 02FF _H | |
| | 03E8 _H to 03EF _H | |
| | 02E8 _H to 02EF _H | |
| – | 0380 _H to 0387 _H | |
| – | 0280 _H to 0287 _H | |
| *) The BIOS searches the addresses in the order 03F8 _H , 02F8 _H , 03E8 _H and 02E8 _H and assigns COM1, COM2, COM3 and COM4 in ascending order. There is no fixed assignment of the I/O addresses to COMx. For example, if only one COM port is detected at address 12E8 _H , this will be COM1. | | |

Example of Setting an AT-Compatible I/O Address

In the following example, the I/O addresses 03F8_H (COM1) for COMa and 02F8_H (COM2) for COMb are to be set in the BIOS setup. Proceed as follows to do this:

1. Select the "IF Modules" page in the BIOS setup.
2. Enter the submodule receptacle number of the interface submodule in "Select Module #".
3. Enter the offset address for the configuration register of the interface submodule "00_H" at "Config.Index".
4. Enter "36_H" at "Value". This value is then written into the configuration register (see also Table 13-13).
5. Press the OK button.

Addressing in the M7-300/400-Reserved I/O Address Area

Regardless of possible addresses in the AT-compatible I/O address area, the IF 962-COM interface submodule can be addressed in this reserved address area.

The base address depends on the interface submodule slot in the expansion module or the programmable module. See the descriptions “M7-300 Expansions”, “M7-400 Expansions” or the description of the M7-400 programmable modules for the slot-dependent base address of the interface submodule.

The I/O address is the sum of the base address and the offset address.

The registers and their meanings and the offset addresses are described below.

Table 13-10 Offset Address Assignments for the IF 962-COM Interface Submodule

| Offset Address | Function | Remarks |
|-----------------------------------|---------------------------|------------|
| 00 _H | Configuration register | Read/write |
| 08 _H - 0F _H | UART 16C552 parallel port | Unused |
| 10 _H - 17 _H | COMa UART 16C552 | Read/write |
| 18 _H - 1F _H | COMb UART 16C552 | Read/write |

Configuration Register

The BIOS setup defines in which AT-compatible I/O address area the COM interface is to be operated or whether it is only to be operated in the reserved I/O address area and this information is stored in the configuration register. Tables 13-11 to 13-13 give you an overview of the possible settings in the configuration register.

Table 13-11 Offset Address for the Configuration Register (IF 962-COM)

| Offset Address | Function | Remarks |
|-----------------|------------------------|------------|
| 00 _H | Configuration register | Read/write |

Table 13-12 Meaning of the Data Bits in the Configuration Register (IF 962-COM)

| Bit 7 | Bit 6 | Bit 5 | Bit 4 | Bit 3 | Bit 2 | Bit 1 | Bit 0 |
|-------|-----------------------|-------|-------|-------|-----------------------|-------|-------|
| 0 | Addressing type COM b | | | 0 | Addressing type COM a | | |

Table 13-13 Meaning of the Addressing Type Bits in the Configuration Register (IF 962-COM)

| I/O Address | Addressing Type COM b/a | | |
|---|-------------------------|---------|---------|
| | Bit 6/2 | Bit 5/1 | Bit 4/0 |
| Addressing only possible in the reserved I/O address area (from C000 _H) (default) | 0 | 0 | 0 |
| 280 _H | 0 | 0 | 1 |
| 2E8 _H | 0 | 1 | 0 |
| 2F8 _H | 0 | 1 | 1 |
| 380 _H | 1 | 0 | 0 |
| 3E8 _H | 1 | 0 | 1 |
| 3F8 _H | 1 | 1 | 0 |
| 0 | 1 | 1 | 1 |

Note

The AT-compatible I/O address can only be set **once** for each COM port of an automation computer (including those permanently installed in a programmable module).

COM Ports

The COM ports (COMa and COMb) of the UART 16C552 can be addressed from offset addresses 10_H or 18_H in accordance with component specification 16C552.

Data Formats

The following data formats can be set in the IF 962-COM interface submodule:

Data bits: 5 bits, 6 bits, 7 bits, 8 bits

Parity: Even, odd, disable

Stop bit: 1 bit, 1.5 bits, 2 bits

Transmission Speed

The following transmission speeds (transmission rates) can be set in the IF962-COM interface submodule:

AT-compatible transmission speeds and transmission speeds up to 115.2 Kbps.

Note

Please note that a safe level of transmission speed depends on factors such as cable length, cable type, and environmental interference.

Interrupt Request

The interface submodule supplies an interrupt request (IRQa and IRQb) for each serial port.

You can define the assignment of the interrupt requests IRQa and IRQb to the appropriate processor interrupt requests in the BIOS Setup.

Table 13-14 Interrupt Assignments of the IF 962-COM Interface Submodule

| Interrupt Source of the Interface Submodule | | ISA Interrupt |
|---|-------|------------------------------|
| COM a | IRQ a | Can be set in the BIOS setup |
| COM b | IRQ b | |

Default settings in the BIOS are: IRQ 4 for COM1 and IRQ3 for COM2.

Submodule ID

The IF 962-COM interface submodule has the submodule ID **41_H**.

13.4.3 Technical Specifications

Technical Specifications

The IF 962-COM interface submodule receives its supply voltage from the M7-400 programmable modules or from the M7-300/400 expansion modules. The current consumption given in the technical specifications is the consumption required for dimensioning the power supply, that is, the current consumption is referenced to 24 V in the M7-300 and to 5 V in the M7-400.

| 6ES7962-3AA00-0AC0 | |
|--|--|
| Technical Specifications | |
| Supply voltage | Supplied from the M7-400 programmable modules or from the M7-300/400 expansion modules |
| Current consumption in the M7-300 (for dimensioning the 24 V current supply) | 0.04 A |
| Current consumption in the M7-400 (for dimensioning the 5 V current supply) | 0.1 A |
| Submodule ID | 41 _H |
| Power losses | 0.5 W |
| Dimensions | |
| W x H x D (mm) | 18.2 x 67 x 97 |
| Weight | 0.080 kg |

13.5 IF 962-LPT Interface Submodule for M7-300/400; (6ES7962-4AA00-0AC0)

Characteristics

The IF 962-LPT interface submodule contains an AT-compatible parallel (LPT) port for connecting a printer with Centronics interface. The IF962-LPT submodule can also be used as a bi-directional data interface. There is a 25-pin sub D socket connector on the frontside of the submodule for plugging in the connecting cable.

Up to four LPT ports can be accessed on AT I/O addresses in one programmable module using standard PC drivers. This also includes LPT ports located on the programmable module itself and those located on expansions. The IF 962-LPT interface submodules can be operated in the AT-compatible address area and, if special drivers are used, also in the M7-300/400-reserved address area.

The cable length on the IF 962-LPT interface submodule should not exceed approximately 3 m.

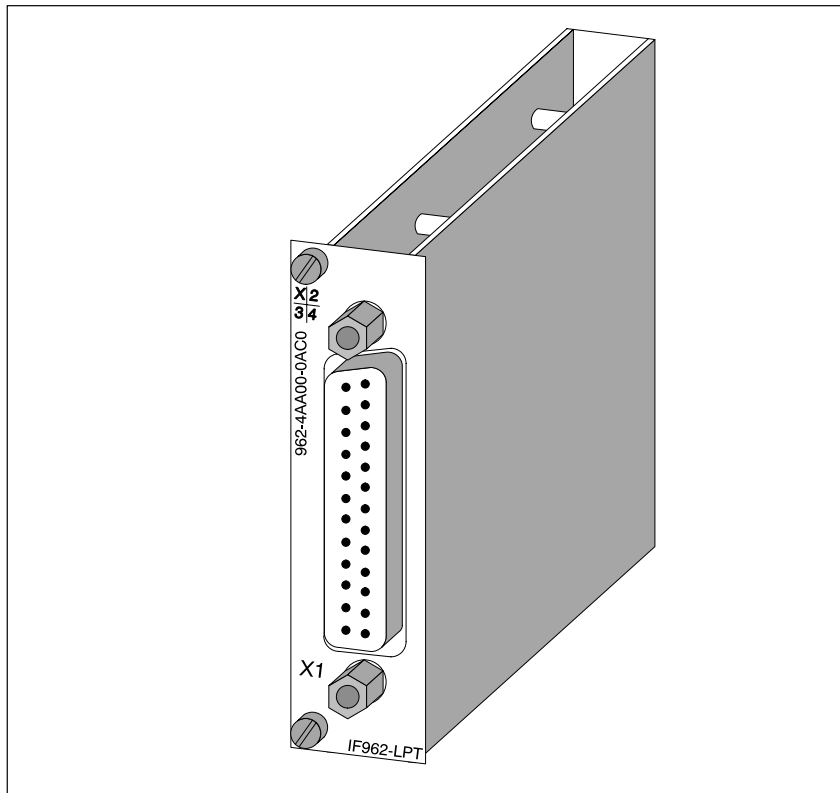

Figure 13-4 IF 962-LPT Interface Submodule

13.5.1 Pin Assignments

X1 Socket

Table 13-15 Socket X1, IF 962-LPT (25-Pin Sub D Socket Connector)

| Pin | Meaning | Direction |
|-----|------------|--------------|
| 1 | /STROBE | Input/output |
| 2 | Data 0 | Input/output |
| 3 | Data 1 | Input/output |
| 4 | Data 2 | Input/output |
| 5 | Data 3 | Input/output |
| 6 | Data 4 | Input/output |
| 7 | Data 5 | Input/output |
| 8 | Data 6 | Input/output |
| 9 | Data 7 | Input/output |
| 10 | /ACK | Input |
| 11 | BUSY | Input |
| 12 | PE | Input |
| 13 | SLCT | Input |
| 14 | /AUTO FEED | Output |
| 15 | /ERROR | Input |
| 16 | /RESET | Output |
| 17 | /SLCT IN | Output |
| 18 | GND | – |
| 19 | GND | – |
| : | GND | – |
| 24 | GND | – |
| 25 | GND | – |

Note

Operational ground (GND signal) at the COMa or COMb ports is referenced to internal ground.

Suitable measures may be required on the process side to avoid ground loops.

13.5.2 Addressing and Interrupts

Addressing

The IF 962-LPT interface submodule can be addressed in the following two ways:

- In the AT-compatible I/O address area
- In the M7-300/400-reserved I/O address area (from C000_H)

Addressing in the AT-Compatible I/O Address Area

The LPT ports can be operated in the AT-compatible I/O address area. The settings are made in the BIOS Setup. You can see the addresses that can be set in the BIOS Setup from the following table.

Table 13-16 Addressing the LPT Ports

| Name | I/O Address | Remarks |
|--|---------------------------------------|--|
| *) | 03BC _H to 3BE _H | Automatically configured by the BIOS and can be set in the BIOS setup. |
| | 0378 _H to 37F _H | |
| | 0278 _H to 27F _H | |
| *) The BIOS searches the addresses in the order 03BC _H , 0378 _H and 0278 _H and assigns LPT1, LPT2 and LPT3 in ascending order. There is no fixed assignment of the I/O addresses to LPTx. For example, if only one LPT port is detected at address 0378 _H , this will be LPT1. | | |

Note

The LPT port in the M7-400 expansion module MSM 478 is always at the I/O address **03BC_H**. For this reason, the I/O address 03BC_H must not be set for the IP 962-LPT interface submodule if an MSM 478 is in use.

Example of Setting an AT-Compatible I/O Address

In the following example, the I/O address 0278_H is to be set in the BIOS setup. Proceed as follows to do this:

1. Select the "IF Modules" page in the BIOS setup.
2. Enter the submodule receptacle number of the interface submodule in "Select Module #".
3. Enter the offset address for the configuration register of the interface submodule "00_H" at "Config.Index".
4. Enter "FE_H" or "02_H" at "Value". This value is then written into the configuration register (see also Table 13-20).
5. Press the OK button.

Addressing in the M7-300/400-Reserved I/O Address Area

Regardless of possible addresses in the AT-compatible I/O address area, the IF 962-COM interface submodule can be addressed in this reserved address area.

The base address depends on the interface submodule slot in the expansion module or the programmable module. See the descriptions "M7-300 Expansions", "M7-400 Expansions" or the description of the M7-400 programmable modules for the slot-dependent base address of the interface submodule.

The I/O address is the sum of the base address and the offset address.

The registers and their meanings and the offset addresses are described below.

Table 13-17 Offset Address Assignments for the IF 962-LPT Interface Submodule

| Offset Address | Function | Remarks |
|-----------------------------------|---------------------------|------------|
| 00 _H | Configuration register | Read/write |
| 10 _H - 17 _H | UART 16C552 parallel port | Read/write |

Default Settings in the BIOS

The following I/O addresses and interrupt numbers are set as defaults in the BIOS for LPT ports:

| Port | I/O Address | Interrupt No. |
|-------------------------------------|-------------|---------------|
| With mass storage module MSM 478 | | |
| LPT1 (on MSM 478) | 03BCH | 7 |
| LPT2 (IF 962-LPT) | 0378H | 5 |
| Without mass storage module MSM 478 | | |
| LPT1 (IF 962-LPT) | 0378H | 7 |
| LPT2 (IF 962-LPT) | 0278H | 5 |

Configuration register

The BIOS setup defines in which AT-compatible I/O address area the LPT interface is to be operated or whether it is only to be operated in the reserved I/O address area and this information is stored in the configuration register. Tables 13-18 to 13-20 give you an overview of the possible settings in the configuration register.

Table 13-18 Offset Address for the Configuration Register (IF 962-LPT)

| Offset Address | Function | Remarks |
|----------------|------------------------|------------|
| 0H | Configuration register | Read/write |

Table 13-19 Meaning of the Data Bits in the Configuration Register (IF 962-LPT)

| Bit 7 | Bit 6 | Bit 5 | Bit 4 | Bit 3 | Bit 2 | Bit 1 | Bit 0 |
|---|-------|-------|-------|-------|-------|---------------------|-------|
| Write: Any ("0" or "1") Read: Always "1" | | | | | | Addressing type LPT | |

Table 13-20 Meaning of the Addressing Type Bits in the Configuration Register (IF 962-LPT)

| I/O Address | Addressing Type | |
|--|-----------------|-------|
| | Bit 1 | Bit 0 |
| Addressing only possible in the reserved I/O address area (from C00 _H) (default) | 0 | 0 |
| 378 _H | 0 | 1 |
| 278 _H | 1 | 0 |
| 3BC _H | 1 | 1 |

Note

The AT-compatible I/O address can only be set **once** for each LPT port of a programmable module.

The LPT port in the M7-400 expansion module MSM 478 is always at the I/O address **03BC_H**. For this reason, the I/O address 03BC_H must not be set for the IP 962-LPT interface submodule if an MSM 478 is in use.

Parallel Port

The parallel port of the interface submodule's UART 16C552 can be addressed from offset address 10_H in accordance with component specification 16C552.

Interrupt Request

The interface submodule supplies an interrupt request (IRQa).

You can define the assignment of the IRQa interrupt request to the relevant processor interrupt request in the BIOS setup.

Submodule ID

The IF 962-LPT interface submodule has the submodule ID **44_H**.

13.5.3 Technical Specifications

Technical Specifications

The IF 962-LPT interface submodule receives its supply voltage from the M7-400 programmable modules or from the M7-300/400 expansion modules. The current consumption given in the technical specifications is the consumption required for dimensioning the power supply, that is, the current consumption is referenced to 24 V in the M7-300 and to 5 V in the M7-400.

| 6ES7962-4AA00-0AC0 | |
|---|--|
| Technical Specifications | |
| Supply voltage | Supplied from the M7-400 programmable modules or from the M7-300/400 expansion modules |
| Current consumption in the M7-300 (for dimensioning the 24 V current supply) | 0.04 A |
| Current consumption in the M7-400 (for dimensioning the 5 V current supply) | 0.1 A |
| Submodule ID | 44 _H |
| Power losses | 0.5 W |
| Dimensions W x H x D (mm) | 18.2 x 67 x 97 |
| Weight | 0.07 kg |

13.6 IF 961-DIO Interface Submodule for M7-300/400; (6ES7961-1AA00-0AC0)

Characteristics

The IF 961-DIO interface submodule has the following characteristics:

- 8 inputs, isolated in groups of 2
Input level 24 VDC; 8.5 mA
Input interrupt at rising and/or falling edge
Input delay can be set in common for all channels: approx. 750 μ s or approx. 3 ms
- 8 outputs, isolated in groups of 4
Level 24 VDC; 0.1A
Outputs short-circuit protected via electronic fuse.

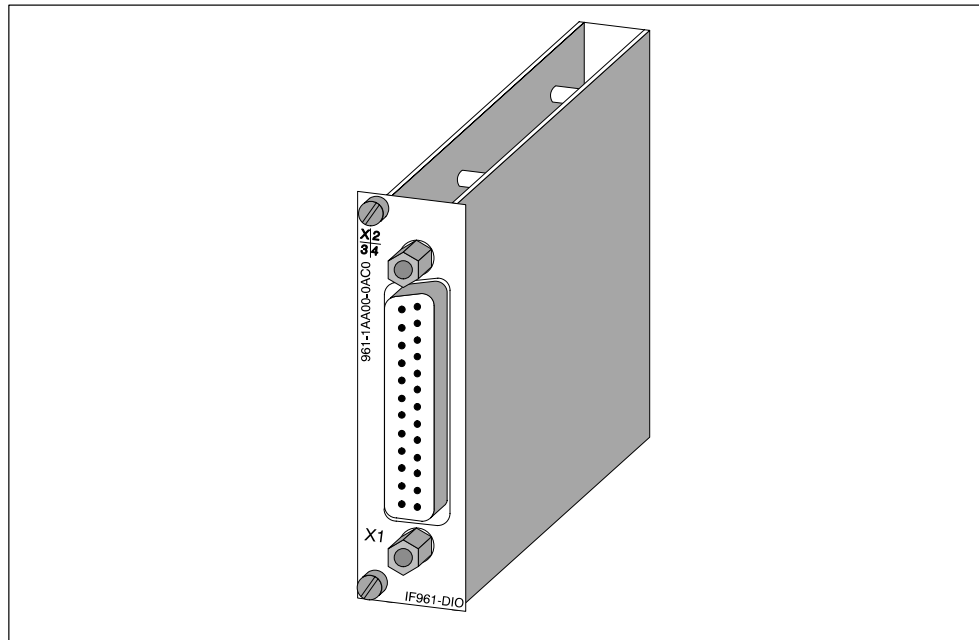

Figure 13-5 IF 961-DIO Interface Submodule

13.6.1 Pin Assignments

X1 Socket

There is a 25-pin sub D socket connector on the frontside of the submodule for plugging in the connecting cable.

Figure 13-6 shows the pin assignments of the submodule.

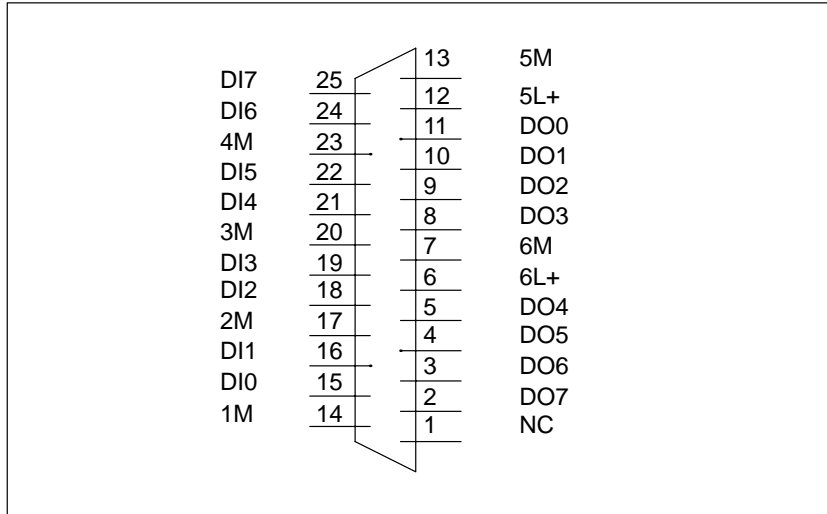

Figure 13-6 X1 Socket Assignments, IF 961-DIO (25-Pin Sub D Connector)

Figures 13-7 and 13-8 show the circuit block diagrams and the terminal connection diagrams for wiring the digital inputs and digital outputs.

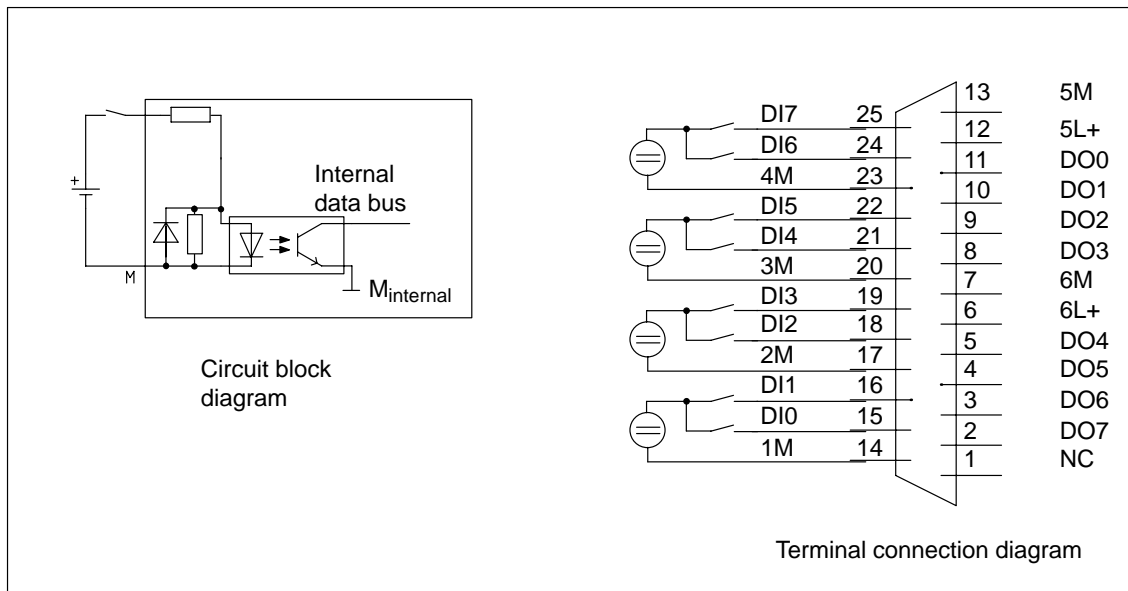

Figure 13-7 Circuit Block Diagram and Terminal Connection Diagram for Wiring the Digital Inputs

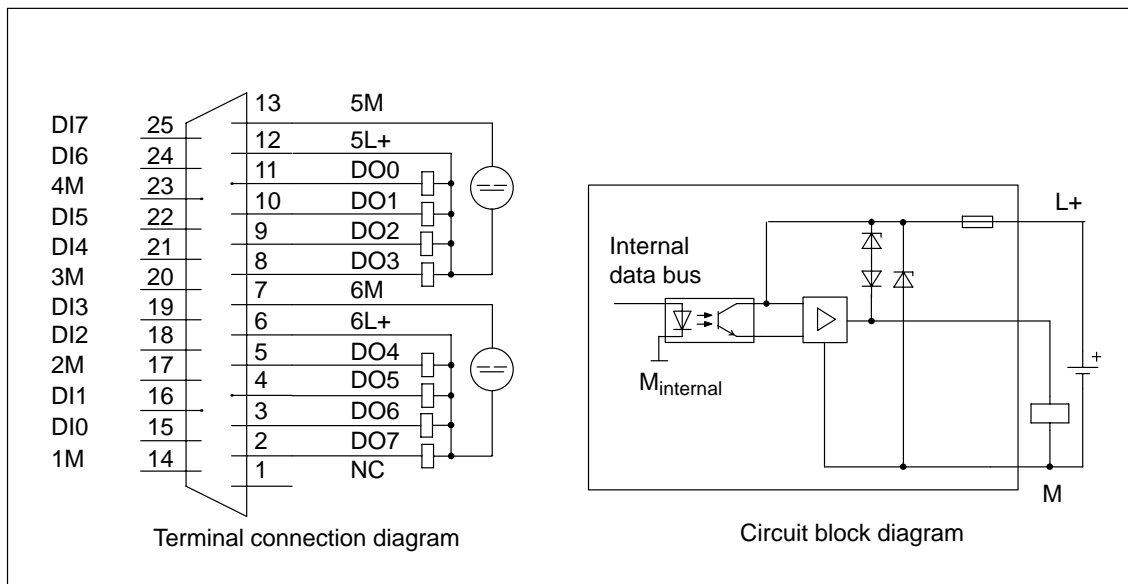

Figure 13-8 Circuit Block Diagram and Terminal Connection Diagram for Wiring the Digital Outputs

13.6.2 Addressing and Interrupts

Addressing in the M7-300/400-Reserved I/O Address Area

The base address depends on the interface submodule slot in the expansion module or the programmable module. See the descriptions “M7-300 Expansions”, “M7-400 Expansions” or the description of the M7-400 programmable modules for the slot-dependent base address of the interface submodule.

The I/O address is the sum of the base address and the offset address.

The registers and their meanings and the offset addresses are described below.

Table 13-21 Offset Address Assignments for the IF 961-DIO Interface Submodule

| Offset Address | Function | Remarks |
|-----------------|-----------------------------------|---|
| 00 _H | User data digital input function | DI0 - DI7 (D igital I nterupt) |
| 01 _H | User data digital output function | DO0 - DO7 (D igital O utput) |
| 02 _H | Acknowledgment register | Acknowledge interrupt |
| 03 _H | Interrupt register | Read cause of interrupt |
| 04 _H | Interrupt enable register | General enable of interrupt |
| 05 _H | Selection register rising edge | Interrupt generation at rising edge of a digital input |
| 06 _H | Selection register falling edge | Interrupt generation at falling edge of a digital input |
| 07 _H | Mode register | Set input delay |

Digital Input Function

Tables 13-22 and 13-23 give an overview of the digital input function.

Table 13-22 Offset Address for the Digital Input Function (IF 961-DIO)

| Offset Address | Function | Remarks |
|----------------|----------------------------------|-----------|
| 0 | User data digital input function | Read only |

Table 13-23 Assignment of the Digital Input (DI) Channels to the Bits (IF 961-DIO)

| Bit | Function | = 0 | = 1 |
|----------------|--------------|------------------------------|-----------------------------------|
| 2 ⁰ | DI channel 0 | In the range -30 V to 5 V | In the range from 13 V to 30 V |
| : | : | : | : |
| 2 ⁷ | DI channel 7 | In the range -30 V to 5 V | In the range from 13 V to 30 V |

Digital Output Function

Tables 13-24 and 13-25 give an overview of the digital output function.

Table 13-24 Offset Address for the Digital Output Function (IF 961-DIO)

| Offset Address | Function | Remarks |
|----------------|-----------------------------------|------------|
| 1 | User data digital output function | Read/write |

Table 13-25 Assignment of the Digital Output (DO) Channels to the Bits (IF 961-DIO)

| Bit | Function | = 0 | = 1 |
|----------------|--------------|-----|--------|
| 2 ⁰ | DO channel 0 | 0 V | + 24 V |
| : | : | : | : |
| 2 ⁷ | DO channel 7 | 0 V | + 24 V |

Acknowledgment Register

The interrupt is acknowledged in this register. Tables 13-26 and 13-27 give an overview of the acknowledgment register.

Table 13-26 Offset Address for the Acknowledgment Register (IF 961-DIO)

| Offset Address | Function | Remarks |
|----------------|-------------------------|------------|
| 2 | Acknowledgment register | Write only |

Table 13-27 Meaning of the Bits in the Acknowledgment Register (IF 961-DIO)

| Bit | Function | = 0 | = 1 |
|----------------|-----------------------|-----|-----|
| 2 ⁰ | Reserved | | |
| : | : | | |
| 2 ⁶ | Reserved | | |
| 2 ⁷ | Acknowledge interrupt | No | Yes |

Interrupt Register

The cause of the interrupt is stored in this register. Tables 13-28 and 13-29 give an overview of the interrupt register.

Table 13-28 Offset Address for the Interrupt Register (IF 961-DIO)

| Offset Address | Function | Remarks |
|----------------|--------------------|-----------|
| 3 | Interrupt register | Read only |

Table 13-29 Meaning of the Bits in the Interrupt Register (IF 961-DIO)

| Bit | Function | = 0 | = 1 |
|----------------|------------------------------|-----|-----|
| 2 ⁰ | Level change at DI channel 0 | No | Yes |
| : | : | : | : |
| 2 ⁷ | Level change at DI channel 7 | No | Yes |

Interrupt Enable Register

Tables 13-30 and 13-31 give an overview of the interrupt enable register.

Table 13-30 Offset Address for the Interrupt Enable Register (IF 961-DIO)

| Offset Address | Function | Remarks |
|----------------|---------------------------|------------|
| 4 | Interrupt enable register | Read/write |

Table 13-31 Meaning of the Bits in the Interrupt Enable Register (IF 961-DIO)

| Bit | Function | = 0 | = 1 |
|----------------|-----------|----------|---------|
| 2 ⁰ | Reserved | | |
| : | : | | |
| 2 ⁶ | Reserved | | |
| 2 ⁷ | Interrupt | Disabled | Enabled |

Selection Register Rising Edge

Tables 13-32 and 13-33 give an overview of the selection register for interrupt generation at a rising edge of a digital input.

Table 13-32 Offset Address for the Selection Register Rising Edge (IF 961-DIO)

| Offset Address | Function | Remarks |
|----------------|--------------------------------|------------|
| 5 | Selection register rising edge | Read/write |

Table 13-33 Meaning of the Bits in the Selection Register Rising Edge (IF 961-DIO)

| Bit | Function | = 0 | = 1 |
|----------------|--|----------|---------|
| 2 ⁰ | Interrupt generation at rising edge of the digital input channel 0 | Disabled | Enabled |
| : | : | : | : |
| 2 ⁷ | Interrupt generation at rising edge of the digital input channel 7 | Disabled | Enabled |

Selection Register Falling Edge

Tables 13-34 and 13-35 give an overview of the selection register for interrupt generation at a falling edge of a digital input.

Table 13-34 Offset Address for the Selection Register Falling Edge (IF 961-DIO)

| Offset Address | Function | Remarks |
|----------------|---------------------------------|------------|
| 6 | Selection register falling edge | Read/write |

Table 13-35 Meaning of the Bits in the Selection Register Falling Edge (IF 961-DIO)

| Bit | Function | = 0 | = 1 |
|----------------|---|----------|---------|
| 2 ⁰ | Interrupt generation at falling edge of the digital input channel 0 | Disabled | Enabled |
| : | : | : | : |
| 2 ⁷ | Interrupt generation at falling edge of the digital input channel 7 | Disabled | Enabled |

Mode Register

Tables 13-36 and 13-37 give an overview of the mode register.

Table 13-36 Offset Address for the Mode Register (IF 961-DIO)

| Offset Address | Function | Remarks |
|----------------|---------------|------------|
| 7 | Mode register | Read/write |

Table 13-37 Meaning of the Bits in the Mode Register (IF 961-DIO)

| Bit | Function | = 0 | = 1 |
|----------------|-------------|------|--------|
| 2 ⁰ | Input delay | 3 ms | 750 ms |
| 2 ¹ | Reserved | | |
| : | : | | |
| 2 ⁷ | Reserved | | |

Reset Status

After switching on the interface submodule, the input delay is set to 3 ms.

Interrupt Request

The interface submodule supplies an interrupt request (IRQa).

You can define the assignment of the IRQa interrupt request to the relevant processor interrupt request in the BIOS setup.

Submodule ID

The IF 961-DIO interface submodule has the submodule ID **02_H**.

13.6.3 Technical Specifications

Technical Specifications

The IF 961-DIO interface submodule receives its supply voltage from the M7-400 programmable modules or from the M7-300/400 expansion modules. The current consumption given in the technical specifications is the consumption required for dimensioning the power supply, that is, the current consumption is referenced to 24 V in the M7-300 and to 5 V in the M7-400.

| 6ES7961-1AA00-0AC0 | | | |
|---|--|--|------------------|
| Dimensions and Weight | | Permissible potential differences | |
| Dimensions W x H x D (mm) | 18.2 x 67 x 97 | • Between the M terminals of the groups | 75 VDC 60 VAC |
| W x H x D (mm) | | • Between the input (M terminal) and the central grounding point | 75 VDC 60 VAC |
| Weight | 0.065 kg | • Isolation checked with | 500 VDC |
| Module-Specific Data | | Supply voltage | |
| Submodule ID | 02 _H | Supplied from the M7-400 programmable modules or from the M7-300/400 expansion modules | |
| Number of inputs | 8 | Current consumption in the M7-300 (for dimensioning the 24 V current supply) | |
| Number of outputs | 8 | 0.03 A | |
| Cable length | | Current consumption in the M7-400 (for dimensioning the 5 V current supply) | |
| • Unshielded | 200 m at 750 μs, 600 m at 3 ms delay time | 0.085 A | |
| • Shielded | 1000 m | Power losses of the module | |
| Voltages, Currents, Potentials | | 2.4 W | |
| Nominal voltage | | | |
| Load current supply L+ | 24 VDC | | |
| Permissible nominal voltage range | | | |
| Load current supply L+ | 20.4 V to 28.8 V | | |
| Reverse polarity protection | No (fuse) | | |
| Current consumption L+ | Dependent on wiring | | |
| Number of inputs that can be controlled simultaneously | 8 | | |
| Number of outputs that can be controlled simultaneously | 8 | | |
| Galvanic isolation | Yes (optocoupler) | | |
| • In groups of | 2 | | |

| Status, Interrupts, Diagnostics | | Data for Selecting an Actuator | |
|---|--|--|-----------------------------------|
| Status indicated | – | Output voltage | |
| Interrupt | 1 sum interrupt from up to 8 sources | • At signal “0” | max. 3 V |
| Diagnostic functions | No | • At signal “1” | L+ - 1.5 V |
| Data for Selecting a Sensor | | Output current | |
| Input voltage | | • At signal “1” | |
| • Nominal value | 24 VDC | nominal value | 0.1 A |
| • For signal “1” | from 13 V to 30 V | permissible range | |
| • For signal “0” | - 30 V to + 5 V | • At signal “0” (residual current) | from 5 mA to 0.1 A max. 100 mA |
| Input current | | Lamp load | max. 2.4 W |
| • At signal “1” | from 4 mA to 8.5 mA | Parallel wiring of 2 outputs | No |
| Input delay time | 750 μs or 3 ms | Setting a digital input | Yes |
| Input characteristic | In accordance with IEC 1131, Part 2 | Switching frequency max. | |
| Type of input in accordance with IEC 1131 | Type 1 | • With resistive load/lamp load | 500 Hz |
| Connection of 2-wire BEROs | Possible under the following conditions: | • At inductive load | 2.0 Hz at 0.1 A |
| • Permissible quiescent current | ≤ 1.5 mA | Inductive cutoff voltage limited (internally) to | L+ - 39 V |
| • Permissible supply voltage | min. 22 V | Short-circuit protection of the output | yes, electronically |

13.7 IF 961-AIO Interface Submodule for M7-300/400; (6ES7961-2AA00-0AC0)

Characteristics

The IF 961-AIO interface submodule has the following characteristics:

- 4 analog inputs, each as voltage and current input
- 2 analog outputs, each as voltage and current output
- 24 VDC external power supply of the analog circuit section
- Hardware interrupt capability and diagnostic capability

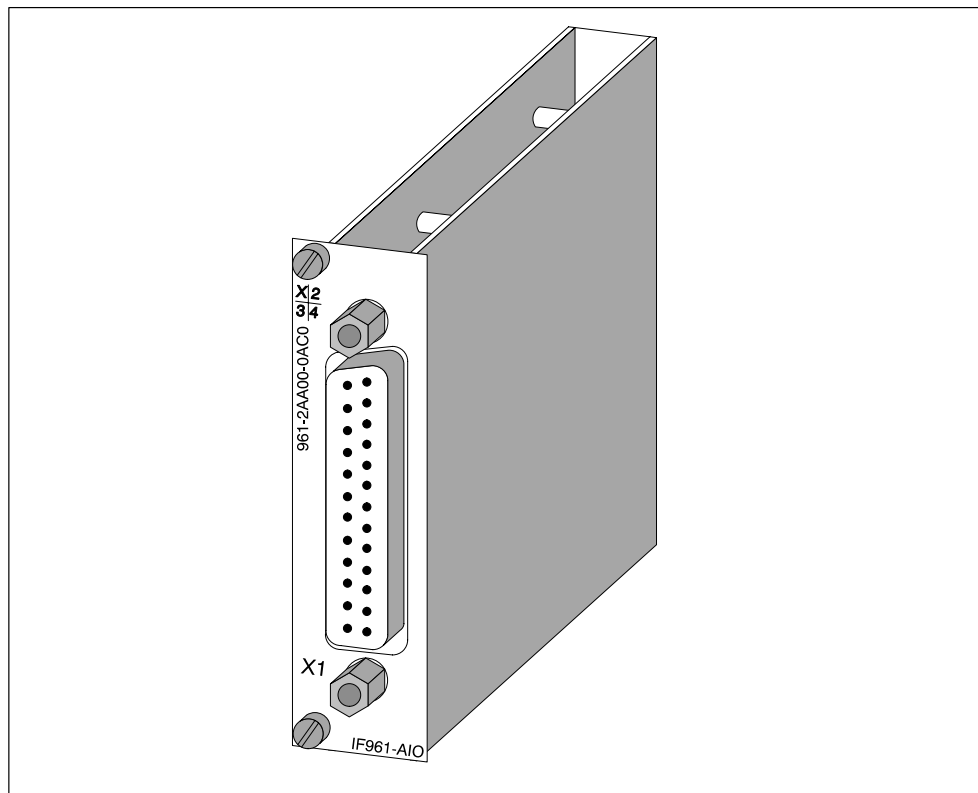

Figure 13-9 IF 961-AIO Interface Submodule

Special Feature of the Measuring Range Selection and Output Range Selection

You select the measuring type (current measuring or voltage measuring) of an input channel via the wiring of the analog inputs (see Figure 13-10). You select the output type (current or voltage output) via the wiring of the analog outputs (see Figure 13-10).

13.7.1 Pin Assignments and Terminal Connection Diagram

X1 Socket

There is a 25-pin sub D socket connector on the frontside of the submodule for plugging in the connecting cable.

Figure 13-10 shows the assignments for the X1 socket and the terminal connection diagram of the submodule.

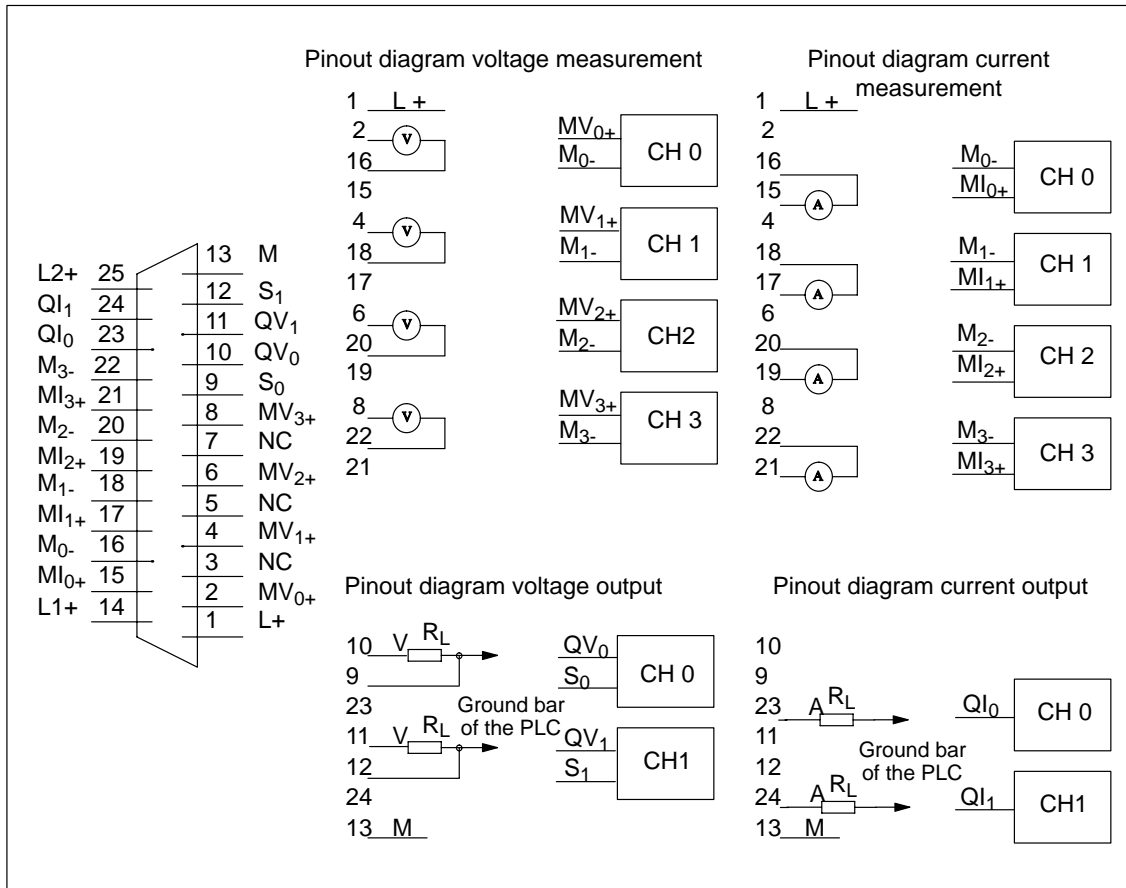

Figure 13-10 X1 Socket Assignments (25-Pin Sub D Connector) and Terminal Connection Diagram of the IF 961-AIO

Note

Use only shielded cables for connecting the inputs and outputs.

Meaning of Signals

The following table shows the meanings of the signals in Figure 13-10.

Table 13-38 Meaning of the Signals of the X1 Socket of the IF 961-AIO Interface Submodule

| Signal | Meaning |
|---------------------------------------|---|
| MV ₀₊ ... MV ₃₊ | Analog inputs: Voltage |
| MI ₀₊ ... MI ₃₊ | Analog inputs: Current |
| M ₀₋ ... M ₃₋ | Reference potential of the analog inputs |
| QV ₀ , QV ₁ | Analog outputs: Voltage |
| QI ₀ , QI ₁ | Analog outputs: Current |
| S ₀ , S ₁ | Reference potential of the analog outputs |
| L ₊ | Voltage supply input 24 VDC |
| L1 ₊ , L2 ₊ | Outputs for supplying the 2-wire transducers (24 VDC) |
| M | Ground (0 V) |

Circuit Block Diagram

Figure 13-11 shows the circuit block diagram of the IF 961-AIO interface submodule.

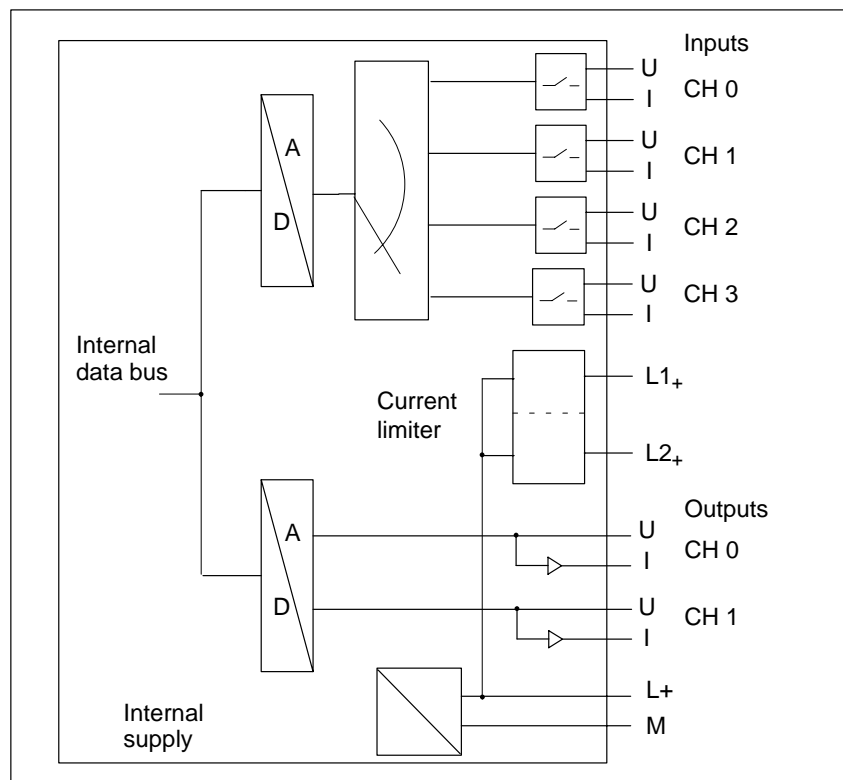

Figure 13-11 Circuit Block Diagram of the IF 961-AIO Interface Submodule

Grounding for the Analog Inputs

If the valid Common Mode area (V_{CM}) cannot be retained, the analog inputs must be grounded. To do this, the ground lines of the individual analog inputs (1) and the shielding must be routed to the grounding point **isolated**.

Refer to Figure 13-12 for the grounding of the analog inputs.

Grounding for the Analog Outputs

To do this, the ground lines of the individual analog outputs (2) and the shielding must be routed to the grounding point **isolated**.

With a grounded installation of the load current supply, the ground terminal of the load current supply must be connected with its own line to the grounding point (3). The following figure shows the grounding of the analog outputs.

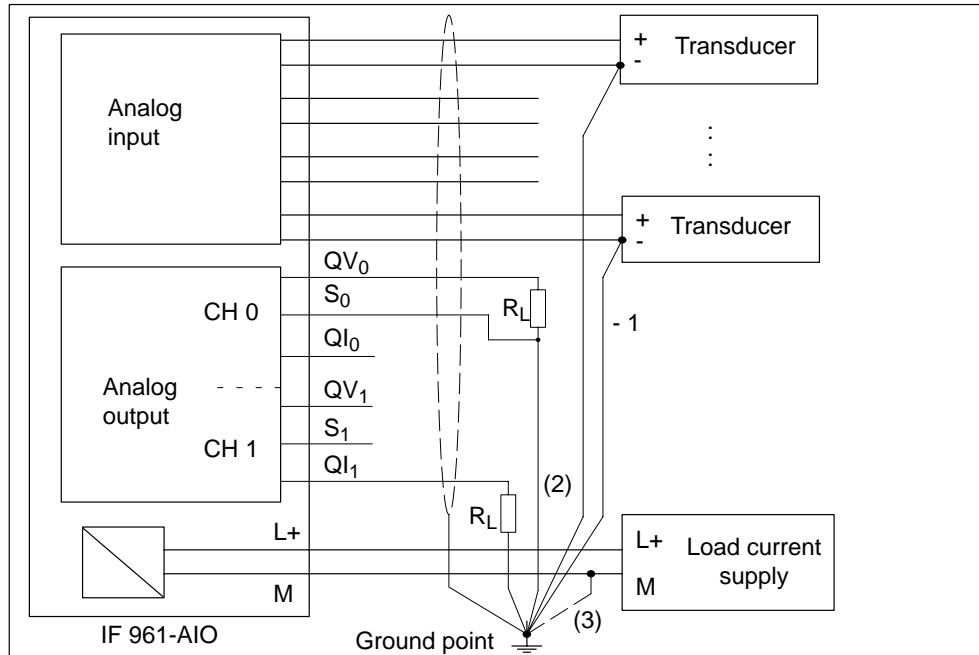

Figure 13-12 Grounding the Analog Inputs/Outputs of the Interface Submodule IF 961-AIO

13.7.2 Connecting Measured Value Sensors to Analog Inputs

Introduction

Depending on the measuring type, you can connect various measured value sensors to the analog inputs:

- Voltage sensors
- Current sensors as
 - two-wire transducers
 - four-wire transducers
- Resistance

This section describes how to connect the measured value sensors and what to look out for when connecting the measured value sensors.

Connecting Measured Value Sensors to Analog Inputs

The maximum permissible voltage difference ($V_{CM} = 8 \text{ V AC}$) between the inputs and the internal ground must not be exceeded.

The measuring ranges (current/voltage) are selected via the wiring of the front connector and by calling the software driver provided for the measuring range.

Unswitched Channels

You must short-circuit unswitched input channels and ground them. This achieves optimal noise immunity for the analog module.

Isolated Measured Value Sensors

Potential differences can occur between the individual measured value sensors in the case of isolated measured value sensors. These potential differences can occur as the result of interference or the physical distribution of the measured value sensors.

Note

Ensure that the V_{CM} (common mode voltage) does not exceed the permissible value. Violation of the permissible value can result in wrong measured values.

Figure 13-13 shows the connection of isolated measured value sensors.

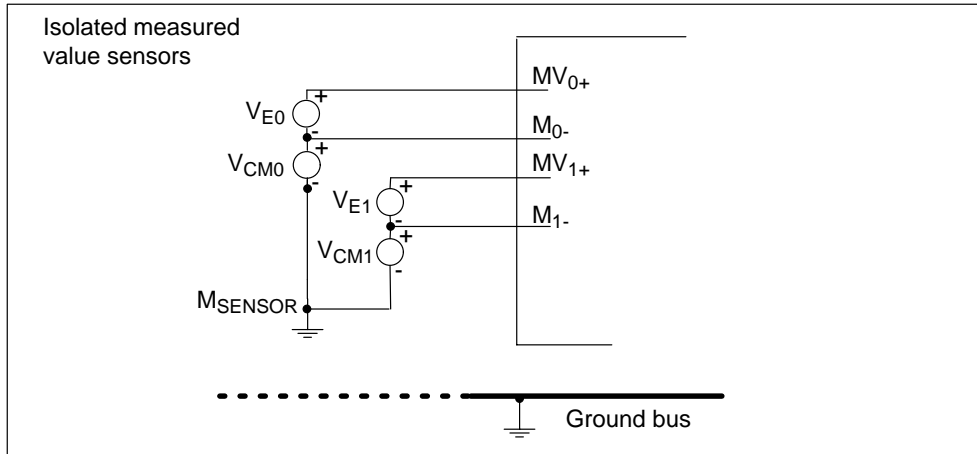

Figure 13-13 Connection of Isolated Measured Value Sensors

Non-Isolated Measured Value Sensors

Potential differences must not arise between non-isolated measured value sensors. If necessary, you must take additional installation measures (equipotential bonding conductor) to ensure this.

Figure 13-14 shows the connection of non-isolated measured value sensors.

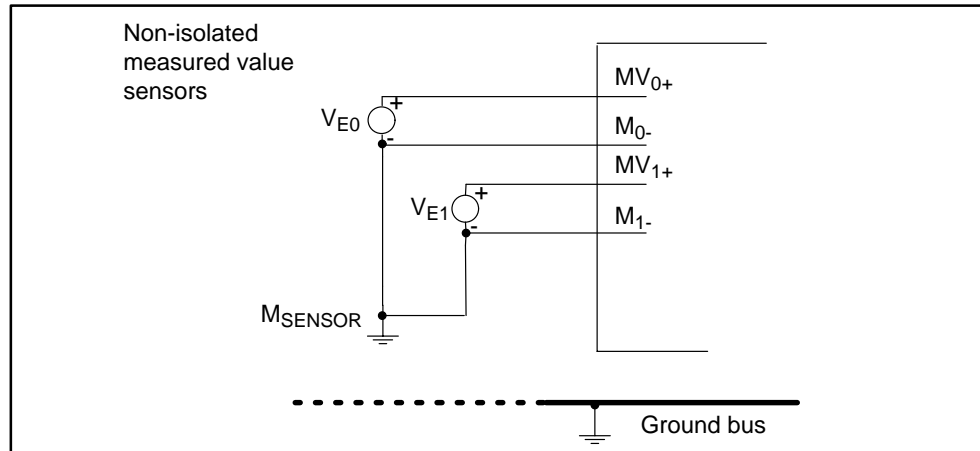

Figure 13-14 Connection of Non-Isolated Measured Value Sensors

Connection of Voltage Sensors

Figure 13-15 shows the connection of voltage sensors to the analog input module.

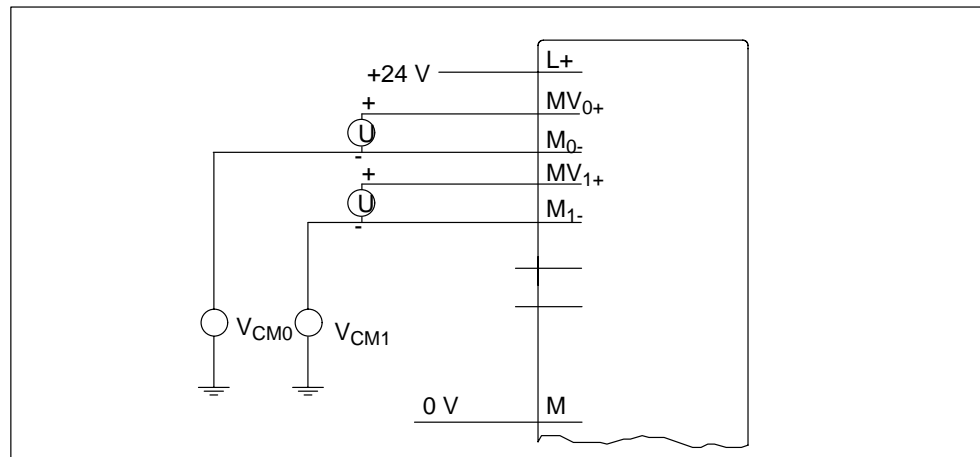

Figure 13-15 Connection of Voltage Sensors

Connection of Current Sensors as Two-Wire and Four-Wire Transducers

Figures 13-16 and 13-17 show you how to connect current sensors as two-wire and four-wire transducers to analog input modules.

The 24 V voltage is supplied to the two-wire transducer via a protected output (L1+, L2+). The two-wire transducer converts the measured variable to a current of 4 to 20 mA. The range 4 to 20 mA is converted to the required format by a software driver function.

Four-wire transducers have a separate supply voltage.

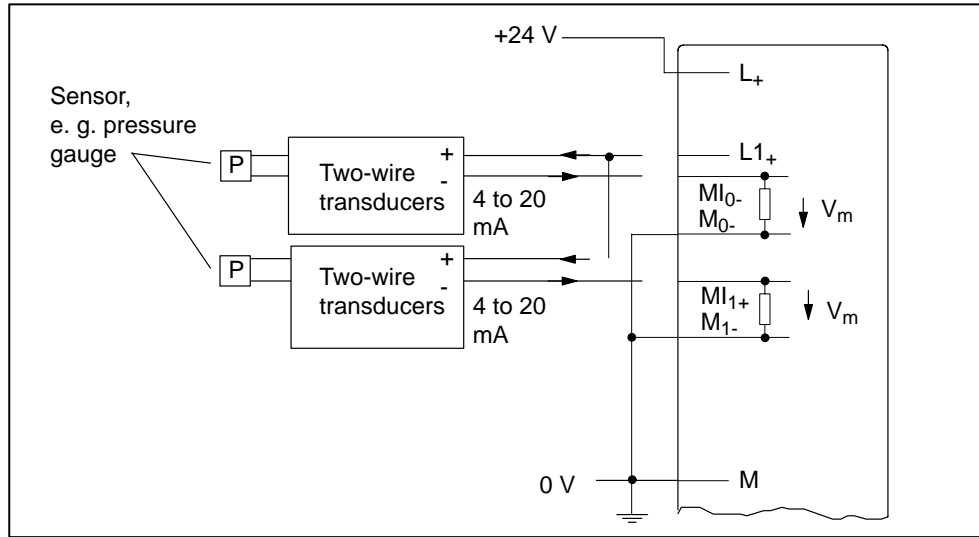

Figure 13-16 Connection of Two-Wire Transducers

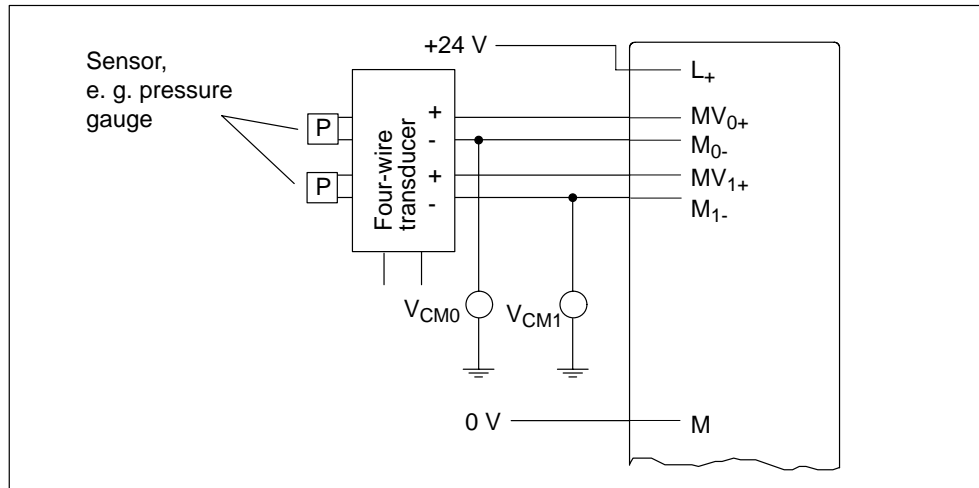

Figure 13-17 Connection of Four-Wire Transducers

Connection of Resistance Thermometers (e.g. Pt 100) and Resistances

The resistance thermometers/resistances are measured in a 4-wire connection. A constant current I_C which can be set is supplied to the resistance thermometers/resistances via one analog output QI each. The voltage arising at the resistance thermometer/resistance is measured over the M_+ and M_- terminals. This achieves a high degree of accuracy in the measured results for 4-wire connection.

The lines carrying the constant current are to be run in parallel to the measuring lines and are not to be connected together until the terminals on the resistance. Voltage drops on the constant current lines will then not corrupt the measured result.

Three-wire connection is not possible in the case of the IF 961-AIO interface submodule.

Figure 13-18 shows the connection of resistance thermometers/resistances with a single current supply via one analog output each.

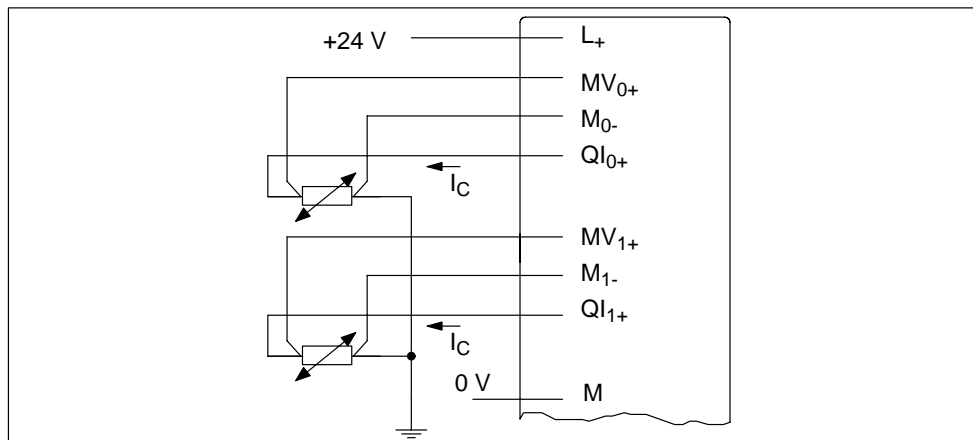

Figure 13-18 Four-Wire Connection of Resistance Thermometers/Resistances with One Constant Current Source Each

Figure 13-19 shows the connection of resistance thermometers/resistances with a common current supply via only one analog output. Please take account here of the maximum permissible load impedance for analog outputs and the maximum permissible common mode voltage (V_{CM}).

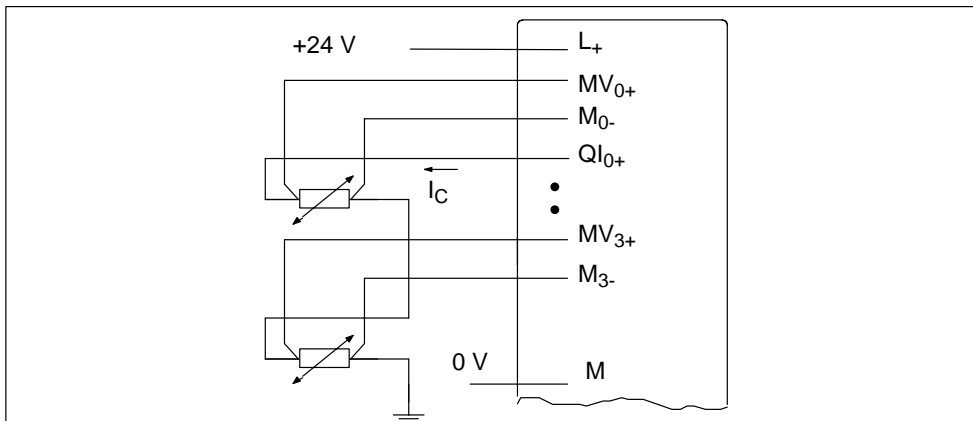

Figure 13-19 Four-Wire Connection of Resistance Thermometers/Resistances with a Common Constant Current Source

13.7.3 Connecting Loads/Actuators to Analog Outputs

Abbreviations Used

The abbreviations used in Figures 13-20 to 13-21 have the following meanings:

- QI: Analog output current
- QV: Analog output voltage
- S: Reference potential of the analog circuit
- R_L : Load resistance

Figures 13-20 and 13-21 show you how you must connect loads/actuators to the current or voltage outputs of the analog output module.

Connecting Loads to the Current Output

The following figure shows wiring on one channel as an example.

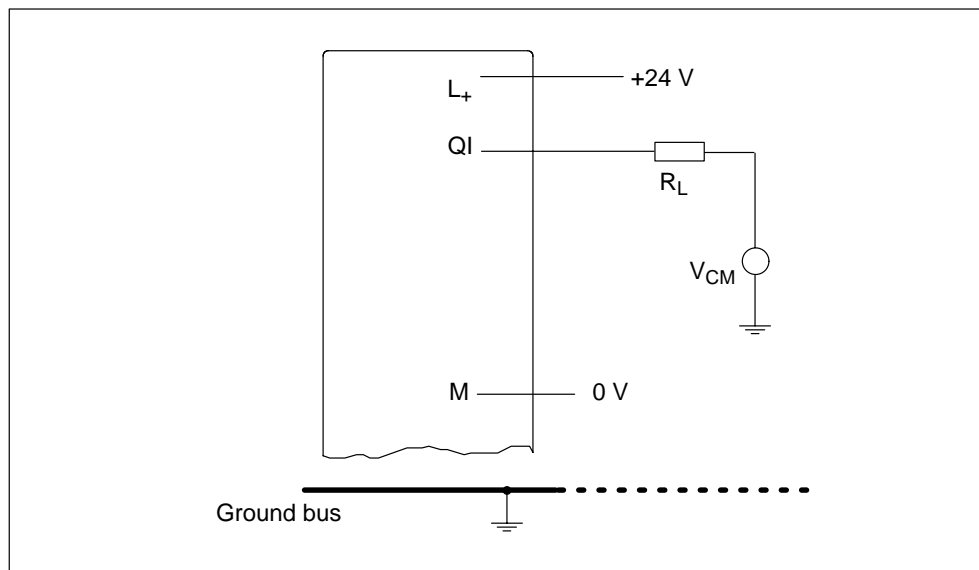

Figure 13-20 Connecting Loads/Actuators via a Two-Wire Connection to a Current Output

Connecting Loads to the Voltage Output

The following figure shows the wiring of two channels as an example.

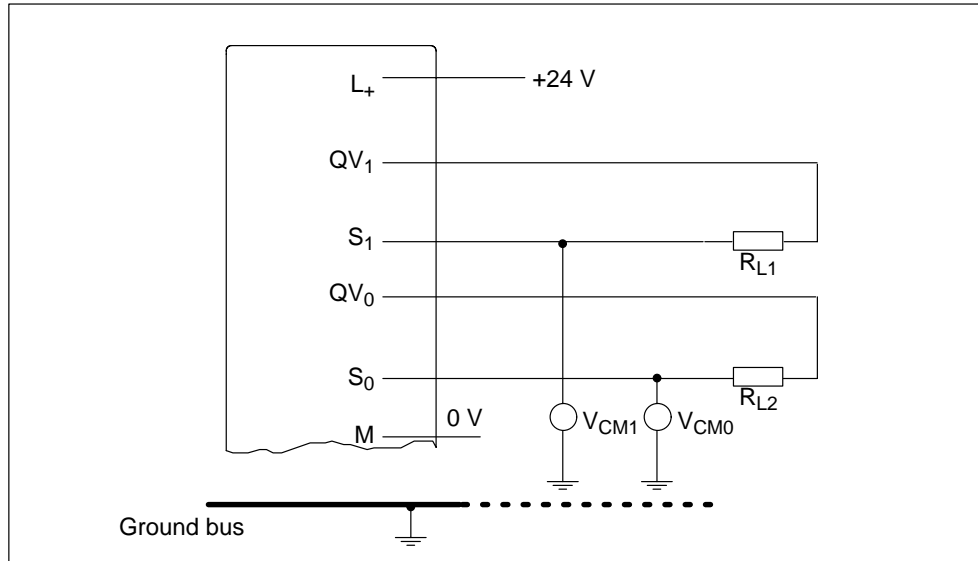

Figure 13-21 Connecting Loads/Actuators via a Three-Wire Connection to a Voltage Output

13.7.4 Conversion Time and Cycle Time of the Analog Input Channels

Introduction

This section contains the definitions of and relationships between the conversion time and the cycle time of analog input modules.

Conversion Time

The conversion time consists of the conversion time of the analog-digital converter (ADC) and the settling time of the multiplexer.

Cycle Time

Analog-digital conversion and transfer of the digitized measured values takes place upon request or by way of multiplexing (parameter assignment required), that is the analog input channels are converted in sequence one after the other. The cycle time, that is, the time until an analog input value has been converted again, is the sum of the conversion times of all analog input channels of the interface submodule.

Figure 13-22 gives a breakdown of the cycle time for an four-channel analog input module.

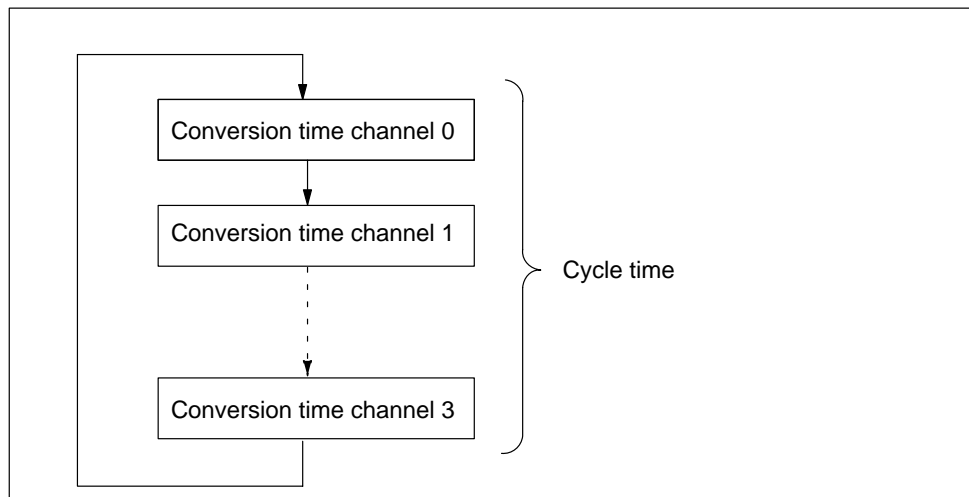

Figure 13-22 Cycle Time of the Analog Input Module

13.7.5 Conversion Time, Cycle Time, Settling Time, and Response Time of the Analog Output Channels

Introduction

This section contains the definitions and relationships of times relevant to the analog output modules.

Conversion Time

The conversion time of the analog output channels includes the transfer of the digitized output values from the internal memory and the digital-analog conversion.

Settling Time

The settling time, that is, the time between the presence of the converted value and reaching the specified value at the analog output, depends on the load. Here, a distinction must be made between resistive, capacitive, and inductive load.

Response Time

The response time, that is, the time between the presence of the digital output values in the internal memory and reaching the specified value at the analog output, is, in the worst case, the sum of the cycle time and the settling time. The worst case arises if the analog channel is converted shortly before transfer of a new output value and converted back only after conversion of the other channels (cycle time).

Figure 13-23 shows the response time of the analog output channels.

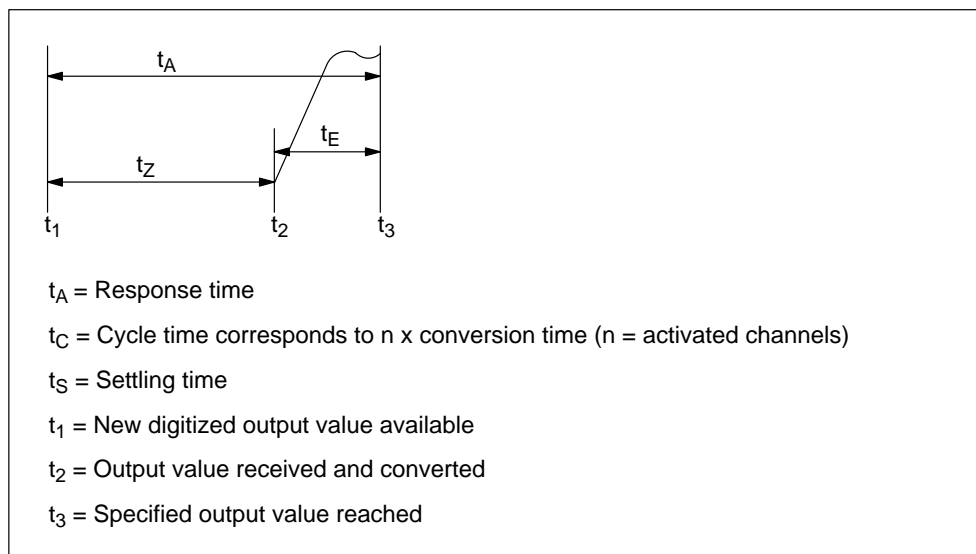

Figure 13-23 Response Time of the Analog Output Channels

13.7.6 Starting Up the IF 961-AIO Interface Submodule

Electrical Installation

You must connect the ground terminal (M and S_0/S_1) of the analog input/output module with the ground terminal of the load power supply. Use a cable with a cross-section of 1 mm² for this purpose.

Unswitched Channels

You must short-circuit unswitched input channels. This achieves optimal noise immunity for the analog module.

Leave unswitched output channels open.

13.7.7 Addressing

Addressing

The IF 961-AIO interface submodule is addressed with the M7-300/400-reserved I/O address area (starting from C000_H).

Addressing in the M7-300/400-Reserved I/O Address Area

The base address depends on the interface submodule slot in the expansion module or the programmable module. See the descriptions “M7-300 Expansions”, “M7-400 Expansions” or the description of the M7-400 programmable modules for the slot-dependent base address of the interface submodule.

The I/O address is the sum of the base address and the offset address.

The registers and their meanings and the offset addresses are described below.

Table 13-39 Offset Address Assignments for the IF 961-AIO Interface Submodule

| Offset Address | Function when Reading | Function when Writing |
|-----------------|---|--|
| 00 _H | ADC data channel 0 ($2^0 - 2^{15}$) | ADC data channel 0 ($2^0 - 2^{15}$) |
| 02 _H | ADC data channel 1 ($2^0 - 2^{15}$) | ADC data channel 1 ($2^0 - 2^{15}$) |
| 04 _H | ADC data channel 2 ($2^0 - 2^{15}$) | Reserved |
| 06 _H | ADC data channel 3 ($2^0 - 2^{15}$) | Reserved |
| 08 _H | Indication of settings such as automatic conversion, cycle time, interrupt enable | Setting of automatic conversion, cycle time and interrupt enable |
| 0A _H | Indication of channel number | Output of channel number |
| 0C _H | Indication of end of conversion (EOC) and voltage fault | Start of analog-digital conversion |
| 0E _H | Reserved | Interrupt acknowledgment |

13.7.8 Analog Output Function

Analog Output Function

The 12-bit digital value to be converted is loaded left-justified into the DAC data registers of the relevant DAC channel. After the data has been written into the register, digital-analog conversion takes place in the selected channel.

You can see the assignment of the address to the output channels and the meaning of the data bits in Table.

The data format of the analog output value is a 16-bit value in twos complement. You can see the representation of the digital output value in Table 13-44.

Table 13-40 Meaning of the Data Bits in the Analog Output Function (IF 961-AIO)

| Offset Address | Writing | | | | | | | | | | | | | | Remark | | |
|-----------------|-----------------|-----------------|----------------|----------------|----------------|----------------|----------------|----------------|----------------|----------------|----------------|----------------|----|---|--------|---|--------------------|
| | D15 | | | | | | | | | | | | D0 | | | | |
| 00 _H | 2 ¹¹ | 2 ¹⁰ | 2 ⁹ | 2 ⁸ | 2 ⁷ | 2 ⁶ | 2 ⁵ | 2 ⁴ | 2 ³ | 2 ² | 2 ¹ | 2 ⁰ | 0 | 0 | 0 | 0 | DAC data channel 0 |
| 02 _H | 2 ¹¹ | 2 ¹⁰ | 2 ⁹ | 2 ⁸ | 2 ⁷ | 2 ⁶ | 2 ⁵ | 2 ⁴ | 2 ³ | 2 ² | 2 ¹ | 2 ⁰ | 0 | 0 | 0 | 0 | DAC data channel 1 |

Status After Switching On

Both output channels contain the value "0".

13.7.9 Analog Input Function

Analog Input Function

Tables 13-41 and 13-42 contain an overview of the read and write registers for the analog input function.

The data format of analog input values is a 16-bit value in two's complement. You can see the representation of the digitized measured value in Table 13-43.

Table 13-41 Meaning of the Input Bits in the Analog Input Function (IF 961-AIO)

| Offset Address | Reading | | | | | | | | | | | | | | | Remark | |
|-----------------|-----------------|-----------------|---|-----------------|-----------------|-----------------|----------------|----------------|----------------|----------------|----------------|----------------|----------------|-----------------|----------------|----------------|---------------------|
| | D15 | | | | | | | | | | | | D0 | | | | |
| 00 _H | 2 ¹⁵ | 2 ¹⁴ | 2 ¹³ | 2 ¹² | 2 ¹¹ | 2 ¹⁰ | 2 ⁹ | 2 ⁸ | 2 ⁷ | 2 ⁶ | 2 ⁵ | 2 ⁴ | 2 ³ | 2 ² | 2 ¹ | 2 ⁰ | ADC data channel 0 |
| 02 _H | 2 ¹⁵ | 2 ¹⁴ | 2 ¹³ | 2 ¹² | 2 ¹¹ | 2 ¹⁰ | 2 ⁹ | 2 ⁸ | 2 ⁷ | 2 ⁶ | 2 ⁵ | 2 ⁴ | 2 ³ | 2 ² | 2 ¹ | 2 ⁰ | ADC data channel 1 |
| 04 _H | 2 ¹⁵ | 2 ¹⁴ | 2 ¹³ | 2 ¹² | 2 ¹¹ | 2 ¹⁰ | 2 ⁹ | 2 ⁸ | 2 ⁷ | 2 ⁶ | 2 ⁵ | 2 ⁴ | 2 ³ | 2 ² | 2 ¹ | 2 ⁰ | ADC data channel 2 |
| 06 _H | 2 ¹⁵ | 2 ¹⁴ | 2 ¹³ | 2 ¹² | 2 ¹¹ | 2 ¹⁰ | 2 ⁹ | 2 ⁸ | 2 ⁷ | 2 ⁶ | 2 ⁵ | 2 ⁴ | 2 ³ | 2 ² | 2 ¹ | 2 ⁰ | ADC data channel 3 |
| 08 _H | A C | I N T | 0 | 0 | 0 | 0 | 0 | 0 | 0 | 0 | 0 | 0 | 0 | ta | ta | ta | Control register 1 |
| 0A _H | 0 | 0 | 0 | 0 | 0 | 0 | 0 | 0 | 0 | 0 | 0 | 0 | 0 | ADC channel no. | | | Control register 2 |
| 0C _H | 0 | 0 | 0 | 0 | 0 | 0 | 0 | 0 | 0 | 0 | 0 | 0 | 0 | P F | E O C | | Status register ADC |
| | ta = 000 | | 5.7 ms cycle time of the automatic conversion function | | | | | | | | | | | | | | |
| | ta = 001 | | 2.8 ms | | | | | | | | | | | | | | |
| | ta = 010 | | 1.3 ms | | | | | | | | | | | | | | |
| | ta = 011 | | 600 μs | | | | | | | | | | | | | | |
| | ta = 100 | | 185 μs | | | | | | | | | | | | | | |
| | INT | | Interrupt enable, INT = 0 = not enabled, INT = 1 = enabled | | | | | | | | | | | | | | |
| | AC = 1 | | Automatic conversion of all ADC channels active | | | | | | | | | | | | | | |
| | ADC channel no. | | Number of the selected ADC channel (in the case of conversion on request) (individual encoding) | | | | | | | | | | | | | | |
| | ADC = 001 | | Channel 0 | | | | | | | | | | | | | | |
| | ADC = 010 | | Channel 1 | | | | | | | | | | | | | | |
| | ADC = 011 | | Channel 2 | | | | | | | | | | | | | | |
| | ADC = 100 | | Channel 3 | | | | | | | | | | | | | | |
| | PF = 1 | | Power failure, no external voltage | | | | | | | | | | | | | | |
| | EOC = 1 | | End of conversion, end of the analog-digital conversion of the selected channel | | | | | | | | | | | | | | |

Table 13-42 Meaning of the Control Bits in the Analog Input Function (IF 961-AIO)

| Offset Address | Writing | | | | | | | | | | | | D0 | | | Remark | |
|-----------------|-----------------|-------------|---|---|---|---|---|---|---|---|---|---|-----------------|----|--------|----------------------------------|--------------------|
| | D15 | | | | | | | | | | | | | | | | |
| 08 _H | A C | I N T | 0 | 0 | 0 | 0 | 0 | 0 | 0 | 0 | 0 | 0 | 0 | ta | ta | ta | Control register 1 |
| 0A _H | 0 | 0 | 0 | 0 | 0 | 0 | 0 | 0 | 0 | 0 | 0 | 0 | ADC channel no. | | | Control register 2 | |
| 0C _H | 0 | 0 | 0 | 0 | 0 | 0 | 0 | 0 | 0 | 0 | 0 | 0 | 0 | 0 | S C | Status register ADC | |
| 0E _H | x | x | x | x | x | x | x | x | x | x | x | x | x | x | x | Acknowledge interrupt x = any | |
| | ta = 000 | | 5.7 ms cycle time of the automatic conversion function | | | | | | | | | | | | | | |
| | ta = 001 | | 2.8 ms | | | | | | | | | | | | | | |
| | ta = 010 | | 1.3 ms | | | | | | | | | | | | | | |
| | ta = 011 | | 600 μs | | | | | | | | | | | | | | |
| | ta = 100 | | 185 μs | | | | | | | | | | | | | | |
| | AC = 1 | | Automatic conversion of all ADC channels active | | | | | | | | | | | | | | |
| | INT = 1 | | Generation of an interrupt after end of cycle | | | | | | | | | | | | | | |
| | ADC channel no. | | Number of the selected ADC channel: | | | | | | | | | | | | | | |
| | ADC = 001 | | channel 0 | | | | | | | | | | | | | | |
| | ADC = 010 | | channel 1 | | | | | | | | | | | | | | |
| | ADC = 011 | | channel 2 | | | | | | | | | | | | | | |
| | ADC = 100 | | channel 3 | | | | | | | | | | | | | | |
| | SC = 1 | | Start of analog-digital conversion, (SC = Start of conversion in the case of individual encoding) | | | | | | | | | | | | | | |

Status After Switching On

| | |
|----------------------|----------------------------------|
| Control register 1: | AC = 0, INT = 0, ta = 0 ⇒ 5.7 ms |
| Control register 2: | ADC = 001 ⇒ ADC channel no. = 0 |
| Status register ADC: | SC = 0 |

Individual Start of an ADC Channel

Below are listed the steps required for individual encoding in the case of an ADC channel:

1. Select the ADC input channel by writing the channel number into control register 2 (offset address "0A_H").
2. Start the ADC conversion by setting the SC bit in the status register ADC to "1" (offset address "0C_H").
3. Read bit "EOC" in the status register ADC at offset address (0C_H) and wait until EOC = 1.
4. Read the analog value at the relevant address (offset addresses "00_H" to "06_H").

Cyclic Conversion of the ADC Channels

Below are listed the steps required for cyclic conversion of the ADC channels:

1. Set the AC bit in control register 1 to "1" (offset address "08_H").
2. Wait for interrupt.
3. Read the values at the relevant address (offset addresses "00_H" to "06_H").
4. Acknowledge the interrupt by writing to the offset address "0E_H", data bits 0 to 15 are irrelevant here.

13.7.10 Analog Value Representation for the Measuring Ranges of the Analog Inputs

Voltage and Current Measuring Ranges

Table 13-43 contains the representation of the digitized measured value for

- The voltage measuring range ± 10 V and
- The current measuring range ± 20 mA.

Table 13-43 Representation of the Digitized Measured Value for the Analog Input Function (Voltage and Current Measuring Range)

| Range | Measured Value in % | Units | | Measuring Range ± 10 V | Measuring Range ± 20 mA |
|---------------|---------------------|---------|-------------------|----------------------------|-----------------------------|
| | | Decimal | Hexadecimal | | |
| Overflow | ≤ 118.51 | 32767 | 7FFF _H | ≤ 11.851 V | ≤ 23.7 mA |
| Ovrange | 117.589 | 32511 | 7EFF _H | 11.7589 V | 23.515 mA |
| | : | : | : | : | : |
| | 100.004 | 27649 | 6C01 _H | 10.0004 V | 20.001 mA |
| Nominal range | 100 | 27648 | 6C00 _H | 10 V | 20 mA |
| | : | : | : | : | : |
| | 0 | 0 | 0 _H | 0 V | 0 mA |
| | : | : | : | : | : |
| | -100 | -27648 | 9400 _H | -10 V | -20 mA |
| Underrange | -100.004 | -27649 | 93FF _H | -10.0004 V | -20.001 mA |
| | : | : | : | : | : |
| | -117.59 | -32512 | 8100 _H | -11.759 V | -23.516 mA |
| Underflow | ≥ -118.51 | -32768 | 8000 _H | ≥ -11.851 V | ≥ -23.7 mA |

13.7.11 Analog Value Representation for the Measuring Ranges of the Analog Outputs

Voltage and Current Output Ranges

Table 13-44 contains the representation of

- The voltage output range ± 10 V and
- The current output range ± 20 mA.

Table 13-44 Representation of the Analog Output Ranges (Voltage and Current Output Ranges)

| Range | Units | | Output Range ± 10 V | Output Range ± 20 mA |
|---------------|---------------|-------------------|----------------------------|-----------------------------|
| | Decimal | Hexadecimal | | |
| Overflow | ≥ 32512 | $\geq 7F00_H$ | 11.851 V | |
| Overrange | 32496 | 7EF0 _H | 11.7534 V | |
| | : | : | : | |
| | 27664 | 6C10 _H | 10.0005 V | |
| Nominal range | 27648 | 6C00 _H | 10 V | 20 mA |
| | : | : | : | : |
| | 0 | 0 _H | 0 V | 0 mA |
| | : | : | : | : |
| Underrange | -27648 | 9400 _H | -10 V | -20 mA |
| | -27664 | 93F0 _H | -10.0005 V | |
| | : | : | : | |
| Underflow | -32512 | 8100 _H | -11.759 V | |
| | ≤ -32528 | $\leq 80F0_H$ | -11.851 V | |

13.7.12 Diagnostics, Interrupts, and Submodule ID

Interrupt Request

The interface submodule supplies an interrupt request (IRQa).

You can define the assignment of the IRQa interrupt request to the relevant processor interrupt request in the BIOS setup.

Diagnostic and Hardware Interrupts

If the interface submodule IF 961-AIO was assigned parameters for cyclic conversion, you have the possibility of initiating hardware interrupts at the end-of-cycle. It is also possible to initiate a diagnostic interrupt if a hardware interrupt is lost.

Submodule ID

The IF 961-DIO interface submodule has the submodule ID **01_H**.

13.7.13 Technical Specifications

Technical Specifications

The IF 961-AIO interface submodule receives its supply voltage from the M7-400 programmable modules or from the M7-300/400 expansion modules. The current consumption given in the technical specifications is the consumption required for dimensioning the power supply, that is, the current consumption is referenced to 24 V in the M7-300 and to 5 V in the M7-400.

| 6ES7961-2AA00-0AC0 | | Voltages, Currents, Potentials | |
|---|-----------------|---|--|
| Dimensions and Weight | | Supply voltage | Supplied from the M7-400 programmable modules or from the M7-300/400 expansion modules |
| Dimensions W x H x D (mm) | 18.2 x 67 x 97 | Current consumption in the M7-300 (for dimensioning the 24 V current supply) | 0.03 A |
| Weight | 0.085 kg | Current consumption in the M7-400 (for dimensioning the 5 V current supply) | 0.085 A |
| Module-Specific Data | | Power losses | 2.5 W |
| Submodule ID | 01 _H | Analog Value Generation for the Inputs | |
| Number of inputs | 4 | Measuring principle | Instantaneous value encoding |
| Number of outputs | 2 | Resolution (incl. overrange) | 16 bits, bipolar, twos complement |
| Cable length, shielded | < 200 m | Conversion time / channel | 35 ms |
| Voltages, Currents, Potentials | | Cycle time (all channels) (automatic conversion) | 5.7 ms, 2.8 ms, 1.3 ms, 600 ms, 185 ms |
| Nominal voltage | | Interference Suppression, Error Limits for Outputs | |
| Load current supply L + | 24 VDC | Load-dependent error at voltage output (R _L in ohms) | Error (in %) = 19 x 100 / (19 + R _L) |
| Current consumption L + | 150 mA | | |
| Reverse polarity protection | No | | |
| Galvanic isolation | No | | |
| Permissible common mode range (V _{CM}) | | | |
| • Inputs to each other or to the central grounding point | < 8 VAC | | |
| • Voltage outputs to each other or to the central grounding point | < 1.5 VDC | | |
| • Current outputs to each other or to the central grounding point | < 2.4 VDC | | |

| Interference Suppression, Error Limits for Inputs | | Analog Value Generation for the Outputs | |
|--|--|---|-----------------------------------|
| Interference voltage suppression for $f = n$ (50/60 Hz \pm 1 %) $n = 1, 2, \dots$ | | Resolution (incl. overrange) | 12 bits, bipolar, twos complement |
| <ul style="list-style-type: none"> Common-mode interference ($V_{pp} < 1$ V) > 60 dB Normal-mode interference (Peak value of interference < nominal value of the input range) 0 dB | | Cycle time (all channels) | Per software |
| Cross-talk attenuation between the inputs > 60 dB | | Interference Suppression, Error Limits for Outputs | |
| Operating error limits (in the entire temperature range, related to the input range) | | Cross-talk attenuation between the outputs | > 60 dB |
| <ul style="list-style-type: none"> Voltage input ± 0.8 % Current input ± 0.8 % | | Operating error limits (over the entire temperature range related to the output range) | |
| Basic error limits (operating error limits at 25°C, related to input range) | | <ul style="list-style-type: none"> Voltage output ± 1.0 % Current output ± 1.0 % | |
| <ul style="list-style-type: none"> Voltage input ± 0.7 % Current input ± 0.7 % | | Basic error limit (operating error limits at 25°C, related to output range) | |
| Linearity error (related to input range) ± 0.05 % | | <ul style="list-style-type: none"> Voltage output ± 0.8 % Current output ± 0.8 % | |
| Repetition accuracy (in settled state at 25°C, related to the input range) ± 0.2 % | | Output ripple (related to "full scale" of the output range; bandwidth 50 kHz) ± 0.1 % | |
| Data for Selecting a Sensor | | Data for Selecting an Actuator | |
| Input ranges (nominal ranges)/input resistance | ± 10 V/100 k Ω ± 20 mA/50 Ω | Output ranges (nominal values) | ± 10 V ± 20 mA |
| Permissible input voltage for voltage input (destruction limit) | ± 18 V | Load impedance | |
| Permissible input current for current input (destruction limit) | ± 40 mA | <ul style="list-style-type: none"> At voltage output min. 2 kW At current output max. 500 W With capacitive load max. 1.6 mF | |
| Connection of signal sensors | | Voltage output | |
| <ul style="list-style-type: none"> For voltage measurement Possible For current measurement | | <ul style="list-style-type: none"> Short-circuit protection Yes Short-circuit current max. 40 mA | |
| As two-wire-transducer | Possible | Current output | |
| As four-wire-transducer | Possible | <ul style="list-style-type: none"> Idle voltage max. 13.1 V | |
| For resistance measurement | Possible ¹⁾ | Connection of actuators | |
| 1) When supplied via analog outputs with a constant current | | <ul style="list-style-type: none"> For voltage output | |
| | | Three-wire connection | Possible |
| | | Four-wire connection (measuring line) | Not possible |
| | | For current output | |
| | | Two-wire connection | Possible |
| | | Status, Interrupts, Diagnostics | |
| | | Interrupts | |
| | | End-of-cycle interrupt | Yes, can be set |
| | | Diagnostic interrupt | Yes, can be set |

13.8 IF 961-CT1 Interface Submodule for M7-300/400; (6ES7961-3AA00-0AC0)

Characteristics

The IF 961-CT1 interface submodule is used for connecting incremental encoders. It has the following characteristics:

- Connection with RS422 or 24 V signals
- 4 digital inputs (START, STOP, SET, RESET), isolated
- 2 digital outputs (Q1, Q2), isolated

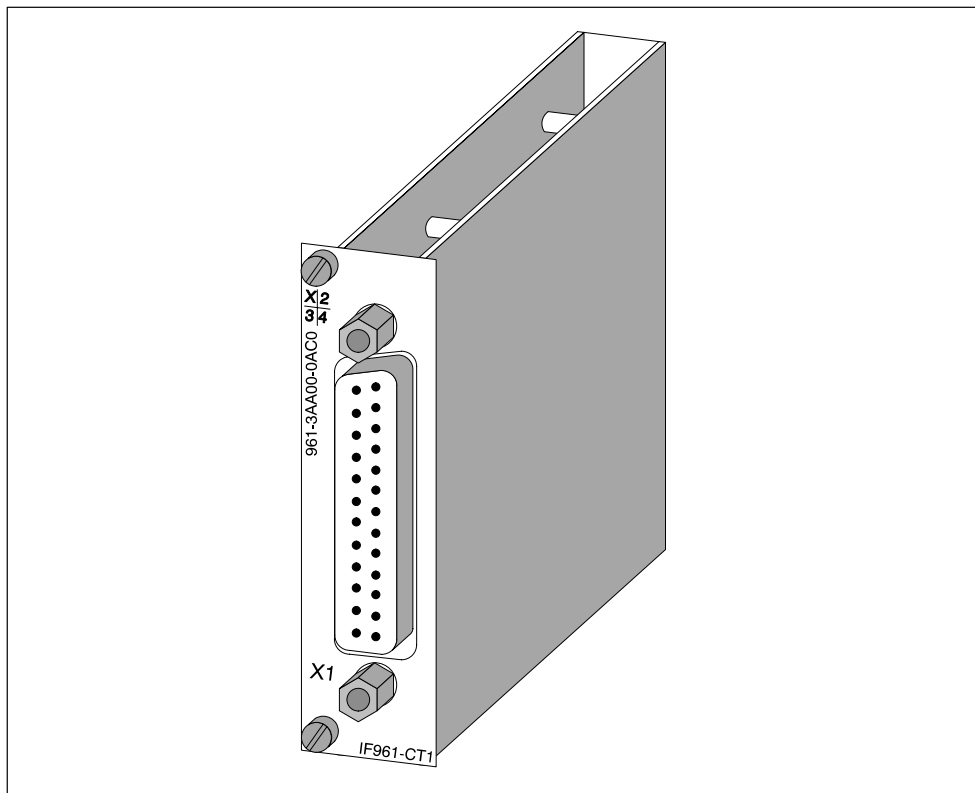

Figure 13-24 IF 961-CT1 Interface Submodule

13.8.1 What Can the IF961-CT1 Interface Submodule Do?

Introduction

This section contains an overview of the functionality of the IF 961-CT1 interface submodule.

This functionality is achieved using the relevant driver software.

What Can the IF 961-CT1 Interface Submodule Do?

The IF 961-CT1 interface submodule is a high-speed counter module. There is a counter on the submodule that can operate in the following counting ranges:

- 0 to 4 294 967 295 or
- - 2 147 483 648 to + 2 147 483 647.

The maximum input frequency of the counter signals is 500 kHz (5 V) or 200 kHz (24V).

You can use the IF 961-CT1 interface submodule for the following counting tasks:

- Endless count
- Single up/down count
- Periodic up/down count

You can start and stop the count either via the user program or via external signals.

Comparison Values

You can store two comparison values on the submodule assigned to the two outputs of the submodule. If the counter status reaches one of the comparison values, the relevant output can be set to initiate control sequences directly in the process.

Initial Value

You can specify an initial value (load value) for the IF 961-CT1. The counter is then set to the initial value when a signal is present at the 24 V digital input on the submodule.

Gate Functions

The count can be started and stopped in dependence on other events via gate functions.

The IF 961-CT1 interface submodule has two gate functions:

- A software gate controlled via the program.
- A hardware gate controlled via the digital inputs of the interface submodule.

Interrupts

The IF 961-CT1 can initiate an interrupt when comparison values are reached or in the event of overflow, underflow, or zero pass of the counter.

Diagnostic Interrupt

The IF 961-CT1 can initiate a diagnostic interrupt for the following events:

- Missing or incorrect counter module parameters
- Hardware interrupt lost
- Signal A, B, or N faulty

Which Signals Can the IF 961-CT1 Count?

The IF 961-CT1 interface submodule can count signals generated by incremental encoders with 5 V differential signals or with 24 V signals.

The IF 961-CT1 interface submodule can also count 24 V signals generated, for example, by a light barrier.

Additional Information

You will find more information about the interface submodule IF 961-CT1 in */108/, IF 961-CT1 Counter Function Module, Programming and Parameter Assignment Manual*.

13.8.2 Addressing and Interrupts

Addressing

The IF 961-CT1 interface submodule is addressed with the M7-300/400-reserved I/O address area (starting from C000_H).

Addressing in the M7-300/400-Reserved I/O Address Area

The base address depends on the interface submodule slot in the expansion module or the programmable module. See the descriptions “M7-300 Expansions”, “M7-400 Expansions” or the description of the M7-400 programmable modules for the slot-dependent base address of the interface submodule.

Interrupt Request

The interface submodule supplies an interrupt request (IRQa).

You can define the assignment of the IRQa interrupt request to the relevant processor interrupt request in the BIOS setup.

Submodule ID

The IF 961-CT1 interface submodule has the submodule ID 03_H.

13.8.3 Technical Specifications

Technical Specifications

The IF 961-CT1 interface submodule receives its supply voltage from the M7-400 programmable modules or from the M7-300/400 expansion modules. The current consumption given in the technical specifications is the consumption required for dimensioning the power supply, that is, the current consumption is referenced to 24 V in the M7-300 and to 5 V in the M7-400.

| 6ES7961-3AA00-0AC0 | | Counter Inputs 24 V | |
|--|--|----------------------------|---|
| Technical Specifications | | Number of counter channels | |
| Supply voltage | Supplied from the M7-400 programmable modules or from the M7-300/400 expansion modules | | 1, alternative to 5 V |
| Current consumption in the M7-300 (for dimensioning the 24 V current supply) | 0.053 A | Low level | - 30 V to + 5 V |
| Current consumption in the M7-400 (for dimensioning the 5 V current supply) | 0.15 A | High level | + 11 V to + 30 V |
| Nominal voltage load current supply 2L+ / 2M | 24 VDC | Input resistance | 1 kΩ |
| Current consumption 2L+ / 2M | Depends on the load of the digital outputs | Input current | typ. 7 mA |
| Type ID | 03 _H | Sensor voltage | No |
| Power losses | 1.5 W | Sensor monitoring | No |
| Dimensions W x H x D (mm) | 18.2 x 67 x 97 | Counter range | 32 bits |
| Weight | 0.07 kg | Max. counter frequency | 200 kHz |
| Counter Inputs 5 V | | Digital Inputs | |
| Number of counter channels | 1, alternative to 24 V | Supply voltage | 2L+ / 2M |
| Level | In accordance to RS422 | Number of inputs | 4 |
| Terminating resistance | approx. 220 ohms | Low level | - 30 V to + 5 V |
| Differential voltage | min 0.5 V | High level | + 11 V to + 30 V |
| Sensor voltage | No | Input current | typ. 7 mA |
| Sensor monitoring | Yes | Galvanic isolation | Yes, to all others except the digital outputs |
| Counter range | 32 bits | Input filter (can be set) | 50 kHz, 200 kHz |
| Max. counter frequency | 500 kHz | Digital Outputs | |
| | | Supply voltage | 2L+ / 2M |
| | | Number of outputs | 2 |
| | | Galvanic isolation | Yes, to all others except the digital inputs |
| | | Output voltage | |
| | | – Low level | max. 3 V |
| | | – High level | 2 L+ - 1.5 V |
| | | Switching current | |
| | | – Nominal value | 0.3 A |
| | | – Range | 5 mA to 0.3 A |
| | | Switching time | max. 300 ms |
| | | Cutoff voltage (inductive) | Limited to 2L+ + 39 V |
| | | Short-circuit protection | Yes, via electronic fuse |

13.9 IF 964-DP Interface Submodule for S7-400 and M7-400

Order Numbers

You can use the IF 964-DP interface submodule with order number 6ES7964-2AA00-0AB0 (up to 07/99) in the M7-400.

You can use the IF 964-DP interface submodule with order number 6ES7964-2AA01-0AB0 (as of 07/99) in the S7-400 and in the M7-400.

Characteristics

The IF 964-DP interface submodule is used for connecting distributed I/O via “PROFIBUS DP”. The submodule has an isolated RS485 interface. The maximum transmission rate is 12 Mbps.

The permissible cable length depends on the transmission rate and the number of nodes. In the case of a point-to-point connection with a speed of 12 Mbps, a cable length of 100 m is possible, and with a speed of 9.6 Kbps a cable length of 1,200 m is possible.

The system can be expanded to 125 stations.

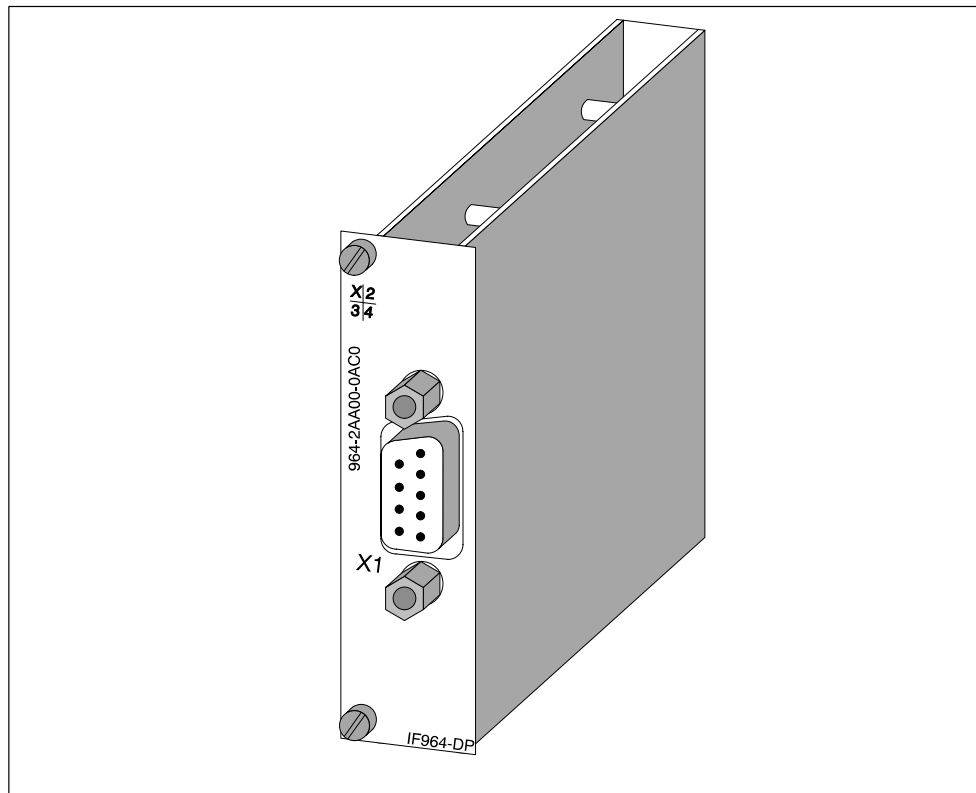

Figure 13-25 IF 964-DP Interface Submodule

Additional Front Cover

The IF 964-DP interface submodule with order number 6ES7964-2AA01-0AB0 has an additional front cover, which is similar to the front cover of the IF 960HF synchronization submodule. As long as this second front cover is not screwed on, the submodule interface on the S7-400 CPU remains off circuit. Only when you insert an IF submodule and screw on the second front cover, is the submodule interface on circuit.

When using the submodule in an M7 the additional front cover has no function, it should, however, be mounted for technical maintenance reasons and due to improved EMC properties.

Note

Even in an S7-400 CPU you may remove or insert the IF 964-DP interface submodule only if it is **off circuit**.

If you remove the front cover of the interface submodule while the power supply is switched on, the CPU goes into DEFECTIVE mode.

Additional Information

You can find information on "PROFIBUS DP" in the following technical overviews or manuals:

- Technical overview *Distributed I/O in SIMATIC S7 and M7*
- Manuals on the DP masters, for example, *S7-300 Programmable Controller* or *S7-400, M7-400 Programmable Controllers* for the PROFIBUS-DP interface of the S7-300
- Manuals on the DP slaves, for example, *ET 200M Distributed I/O Device* or *ET 200C Distributed I/O Device*
- The manual on the network components *SINEC L2/L2FO Network Manual*, such as bus connectors, RS 485 repeaters
- Manuals on STEP 7

13.9.1 Pin Assignments

X1 Connector

There is a 9-pin sub D socket connector on the frontside of the submodule for plugging in the connecting cable. See Table 13-45 for the pin assignments.

Table 13-45 X1 Socket, IF 964-DP (9-Pin Sub D Connector)

| Pin | Signal | Meaning | Direction |
|-----|-------------------|--|--------------|
| 1 | – | | |
| 2 | M 24 | 24 V reference potential (6ES7 964-2AA01-0AB0) | Output |
| 3 | LTG_B | Line B | Input/Output |
| 4 | RTSAS | Request to send (AS) | Output |
| 5 | M5 _{ext} | Operational ground (isolated) | Output |
| 6 | P5 _{ext} | + 5 V (isolated), max. 20 mA (for supplying the bus terminator) | Output |
| 7 | P 24 V | +24 V, max. 150 mA, non-isolated (6ES7 964-2AA01-0AB0) | Output |
| 8 | LTG_A | Line A | Input |
| 9 | – | | |

What Can be Connected to the Interface Submodule?

Devices with PROFIBUS can be connected, such as the following:

ET 200 M, ET 200 U (B/C) and other devices conforming to the standard.

Additional S7 DP masters (PG, OP)

13.9.2 Addressing and Interrupts

In the M7-300/400-Reserved I/O Address Area

The base address depends on the interface submodule slot in the expansion module or the programmable module. See the descriptions “M7-300 Expansions”, “M7-400 Expansions” or the description of the M7-400 programmable modules for the slot-dependent base address of the interface submodule.

You require the base address for assigning parameters to the driver software.

Intermediate Memory

The IF 964-DP interface submodule provides (intermediate) storage of the data in the dual-port RAM. The size of the memory and its address can be assigned via the driver used.

Protected Mode: 1 out of 8 areas of 512 Kbytes in the address area
C0 00 00_H bis FF FF FF_H.

Note

The memory address must not collide with other system addresses. The IF 964-VGA interface submodule, for example, occupies the addresses from C 00 00_H to C 7F FF_H.

Interrupt Request

The interrupt line of the interface submodule is switched with a processor interrupt per software parameter assignment.

Addressing in the S7-400 I/O Address Area

The interface submodule can be accessed by the respective interface in an assigned address window.

Interrupt Request

The interrupt line of the interface submodule is permanently assigned to the processor interrupt.

Submodule ID

The IF 964-DP interface submodule has the submodule ID **8C_H**.

13.9.3 Technical Specifications

Technical Specifications

The IF 964-DP interface submodule receives its supply voltage in the S7-400 from the central processing unit and in the M7-400 from the programmable modules or from the expansion modules. The current consumption given in the technical specifications is the consumption required for dimensioning the power supply, that is, the current consumption is referenced to 24 V in the M7-300 and to 5 V in the M7-400.

| 6ES7964-2AA00-0AB0 | | 6ES7964-2AA01-0AB0 | |
|--|---|---|---|
| Performance Features | | Performance Features | |
| Transmission rate | 9.6 Kbps to 12 Mbps | Transmission rate | 9.6 Kbps to 12 Mbps |
| Cable length | | Cable length | |
| • At 9.6 Kbps | 1200 m max. | • At 9.6 Kbps | 1200 m max. |
| • At 12 Mbps | 100 m max. | • At 12 Mbps | 100 m max. |
| Number of stations | ≤ 125 | Number of stations | ≤ 125 |
| Backup memory (dual-port RAM) | 256 Kbytes | Backup memory (dual-port RAM) | 256 Kbytes |
| Physical interface | RS485 | Physical interface | RS485 |
| Galvanic isolation | Yes | Galvanic isolation | Yes |
| Technical Specifications | | Technical Specifications | |
| Supply voltage | Supplied from the M7-400 programmable modules or from the M7-300/400 expansion modules | Supply voltage | Supplied from the S7-400 or from the M7-400 programmable modules or from the M7-300/400 expansion modules |
| Current consumption in the M7-300 (for dimensioning the 24 V power supply) The module does not consume any current at 24 V, and it only makes this voltage available at the DP interface. | Total current consumption of the components connected to the DP interface, with a maximum of 150 mA | Current consumption from the S7-400 bus/in M7-300 (DC 24 V for the dimensioning of the 24 V power supply) The module does not consume any current at 24 V, and it only makes this voltage available at the DP interface. | Total current consumption of the components connected to the DP interface, with a maximum of 150 mA |
| Current consumption in the M7-400 (for dimensioning the 5 V power supply) | 0.45 A | . | . |
| Current carrying capacity of the isolated 5 V (P5 _{ext}) | Max. 90 mA | Current carrying capacity of the isolated 5 V (P5 _{ext}) | Max. 90 mA |
| Load rating of the isolated 5V (P5 _{ext}) | max. 90 mA | Load rating of the isolated 5V (P5 _{ext}) | max. 90 mA |
| Submodule ID | 8C _H | Load rating of the 24 V | max. 150 mA |
| Power losses | 2 W | Submodule ID | 8C _H |
| Dimensions | | Power losses | 2 W |
| W x H x D (mm) | 18.2 x 67 x 97 | Dimensions | |
| Weight | 0.065 kg | W x H x D (mm) | 18.2 x 67 x 97 |
| | | Weight | 0.065 kg |

Parameter Sets for Signal Modules

A

Chapter Overview

| Section | Description | Page |
|----------------|---|-------------|
| A.1 | How to Assign the Parameters for Signal Modules in the User Program | A-2 |
| A.2 | Parameters of the Digital Input Modules | A-4 |
| A.3 | Parameters of the Digital Output Modules | A-7 |
| A.4 | Parameters of the Analog Input Modules | A-10 |

A.1 How to Assign the Parameters for Signal Modules in the User Program

Parameter Assignment in the User Program

You have already assigned parameters to the modules in *STEP 7*.

In the user program, you can use a SFC:

- to reassign parameters to the module and
- and transfer the parameters from the CPU to the addressed signal module

In the M7-400

In M7-400 programmable controllers you can also parameterize the signal modules in the user program with the *M7 API* software (refer to *System Software Manuals for M7-300/400*).

Parameters Stored in Data Records

The signal module parameters are stored in data records 0 and 1.

Modifiable Parameters

You can change the parameters of record 1 and pass them to the signal module using SFC 55. The parameters set on the CPU are not changed when you do this!

You cannot modify the parameters of data record 0 in the user program.

SFCs for Parameter Assignment

The following SFCs are available for assigning parameters to the signal modules in the user program:

Table A-1 SFCs for assigning Parameters to Signal Modules

| SFC No. | Identifier | Application |
|---------|------------|--|
| 55 | WR_PARM | Transfer of modifiable parameters (data record 1) to the addressed signal module. |
| 56 | WR_DPARM | Transfer of parameters (data record 0 or 1) from the CPU to the addressed signal module. |
| 57 | PARM_MOD | Transfer of all parameters (data record 0 and 1) from the CPU to the addressed signal module. |

Description of the Parameters

The following sections contain **all** the modifiable parameters for the various module classes. The parameters of the signal modules are described:

- in the online help of *STEP 7*.
- in this reference manual

You will find the parameters that can be adjusted for the signal module concerned in the specific sections for the different signal modules.

Further References

You can find an in-depth description of the principle of assigning parameters to signal modules in the user program and a description of the SFCs that can be used for this purpose in the *STEP 7* manuals.

A.2 Parameters of the Digital Input Modules

Parameters

The table below contains all the parameters you can set for digital input modules.

You will see which parameters you can modify from the list:

- in *STEP 7*
- with SFC 55 "WR_PARM"

The parameters set with *STEP 7* can also be transferred to the module with SFCs 56 and 57 (refer to the *STEP 7* manuals).

Table A-2 Parameters of the Digital Input Modules

| Parameter | Data Record No. | Parameters Can Be Assigned with ... | |
|--------------------------------------|-----------------|-------------------------------------|------------|
| | | ... SFC 55 | ... STEP 7 |
| Destination CPU for interrupts | 0 | No | Yes |
| Input delay | | No | Yes |
| Diagnostics | | No | Yes |
| Hardware interrupt enable | 1 | Yes | Yes |
| Diagnostic interrupt enable | | Yes | Yes |
| Reaction to error* | | Yes | Yes |
| Hardware interrupt with rising edge | | Yes | Yes |
| Hardware interrupt with falling edge | | Yes | Yes |
| Substitute "1" | | Yes | Yes |

* Only in 6ES7421-7BH00-0AB0

Note

If you want to enable the diagnostic interrupt in the user program in data record 1, you must enable the diagnosis in data record 0 beforehand using *STEP 7*.

Structure of Data Record 1

The figure below shows the structure of data record 1 (bytes 0, 1, 2 and 3) for the parameters of the digital input modules.

You enable a parameter by setting the corresponding bit to "1".

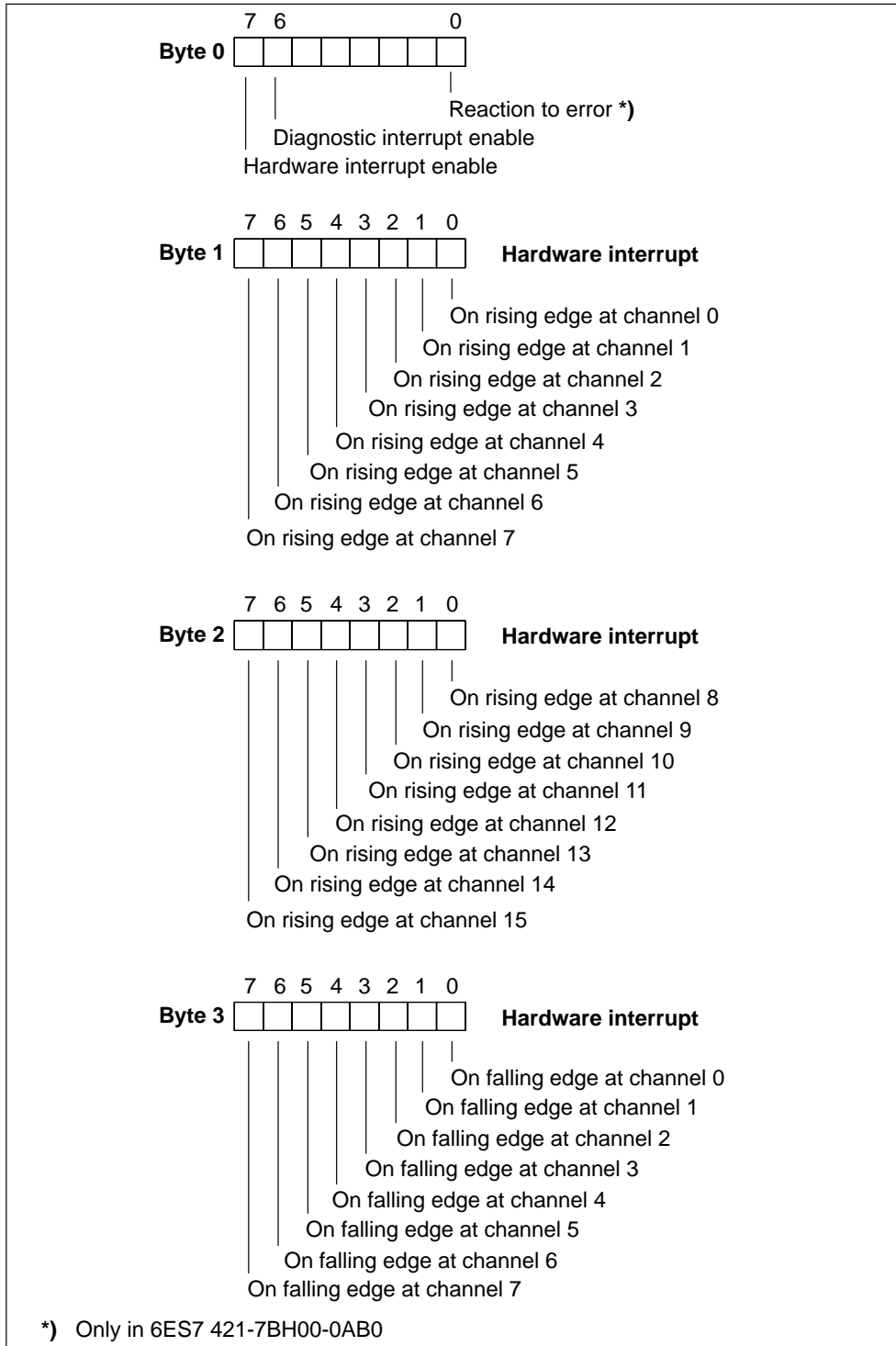

Figure A-1 Data Record 1 of the Parameters of the Digital Input Modules

The figure below shows the structure of data record 1 (bytes 4, 5 and 6) for the parameters of the digital input modules.

You enable a parameter by setting the corresponding bit to "1".

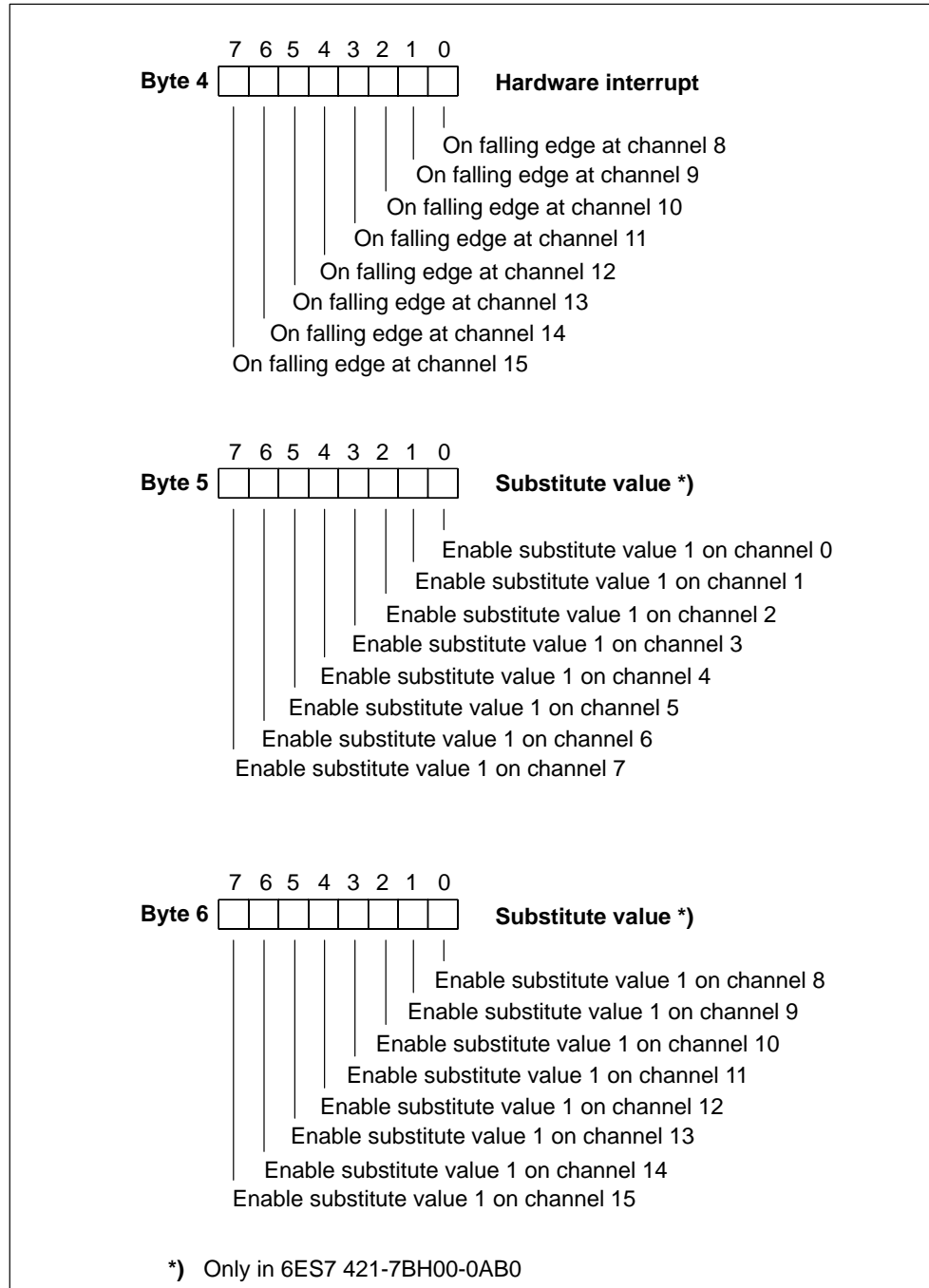

Figure A-2 Data Record 1 for Parameters of the Digital Input Modules

A.3 Parameters of the Digital Output Modules

Parameters

The table below contains all the parameters you can set for digital output modules. The comparison shows:

- Which parameters you can change with STEP 7 and
- Which parameters you can change with SFC 55 "WR_PARM"

The parameters set with STEP 7 can also be transferred to the module with SFCs 56 and 57 (refer to the STEP 7 manuals).

Table A-3 Parameters of the Digital Output Modules

| Parameter | Data Record No. | Parameters Can Be Assigned with ... | |
|--------------------------------|-----------------|-------------------------------------|------------|
| | | ... SFC 55 | ... STEP 7 |
| Destination CPU for Interrupts | 0 | No | Yes |
| Diagnostics | | No | Yes |
| Diagnostic interrupt enable | 1 | Yes | Yes |
| Reaction to CPU STOP | | Yes | Yes |
| Enable substitute value "1" | | Yes | Yes |

Note

If you want to enable the diagnostic interrupt in the user program in data record 1, you must enable the diagnosis in data record 0 beforehand using *STEP 7*.

Structure of Data Record 1

The figure below shows the structure of data record 1 (bytes 0, 1 and 2) for the parameters of the digital output modules.

You enable a parameter by setting the corresponding bit to “1”.

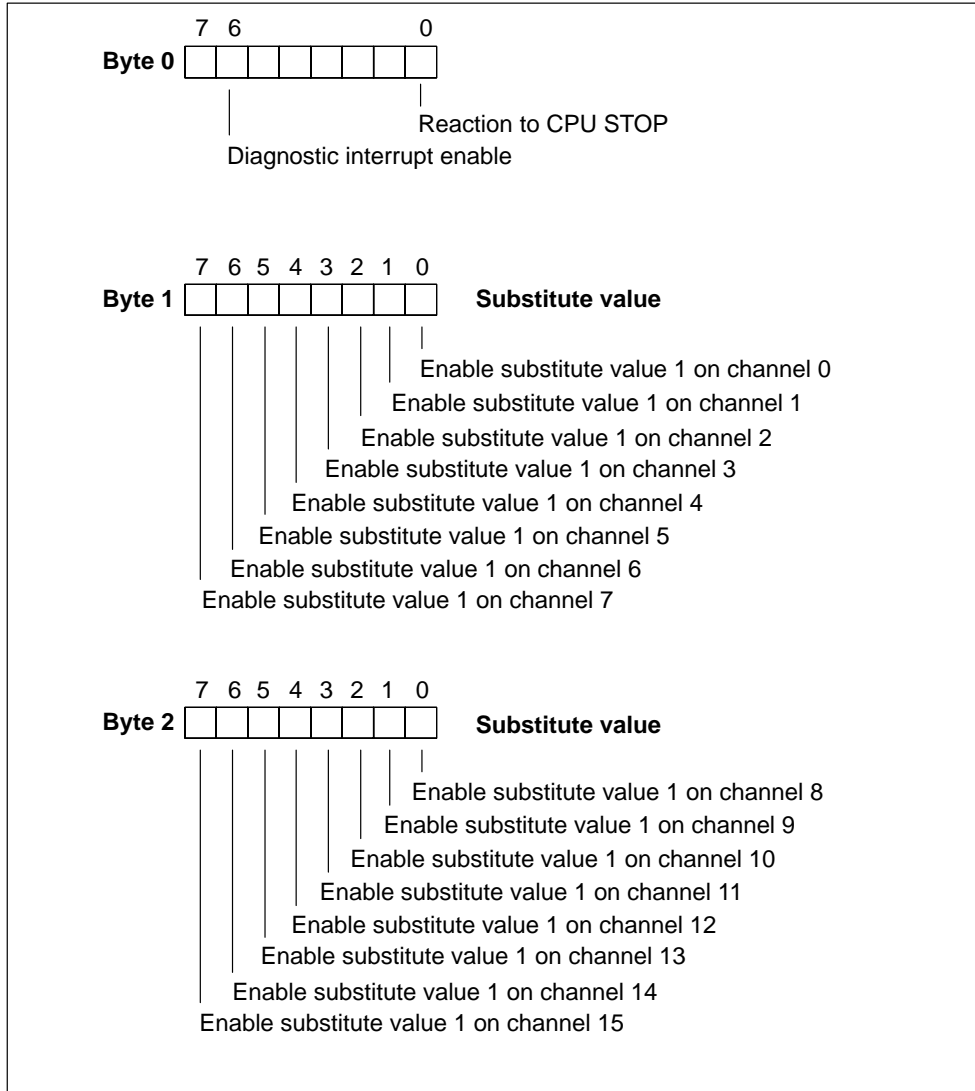

Figure A-3 Data Record 1 for Parameters of the Digital Output Modules

The figure below shows the structure of data record 1 (bytes 3 and 4) for the parameters of the digital output modules.

You enable a parameter by setting the corresponding bit to “1”.

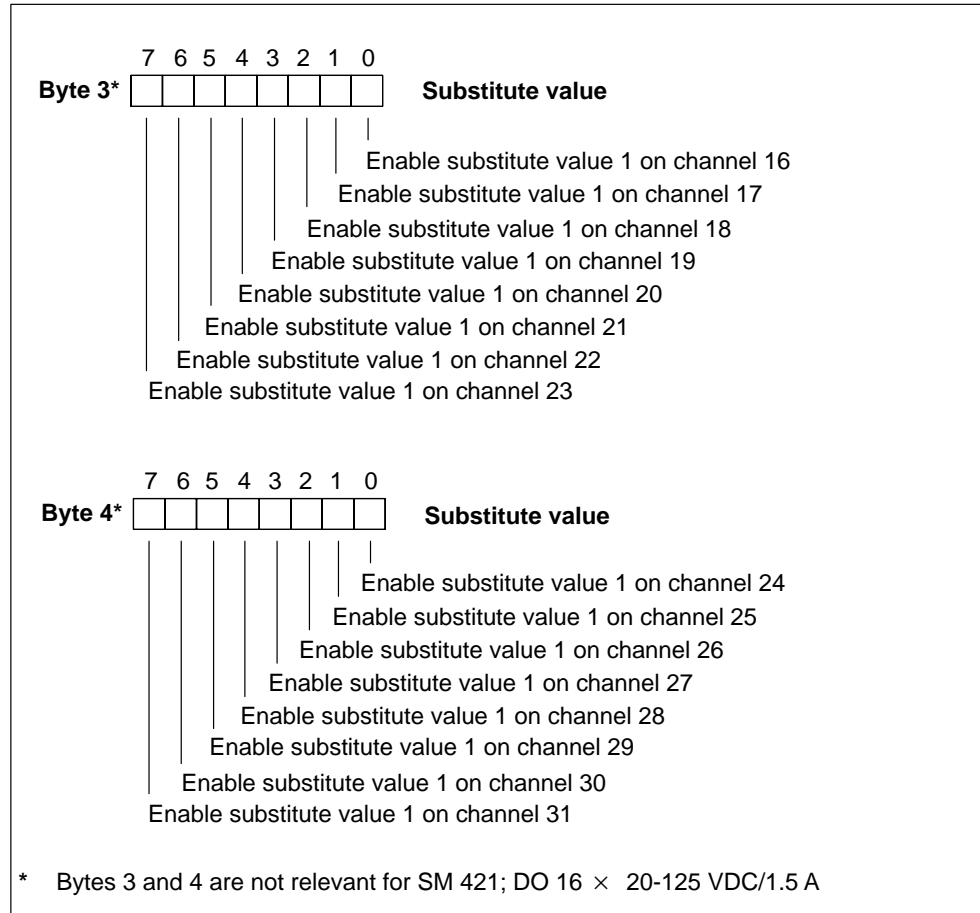

Figure A-4 Data Record 1 for Parameters of the Digital Output Modules

A.4 Parameters of the Analog Input Modules

Parameters

The table below contains all the parameters you can set for analog input modules.

You will see which parameters you can modify from the list:

- in *STEP 7*
- with SFC 55 "WR_PARM"

The parameters set with *STEP 7* can also be transferred to the module with SFCs 56 and 57 (refer to the *STEP 7* manuals).

Table A-4 Parameters of the Analog Input Modules

| Parameter | Data Record No. | Parameters Can Be Assigned with ... | |
|--------------------------------|-----------------|-------------------------------------|------------|
| | | ... SFC 55 | ... STEP 7 |
| Destination CPU for Interrupts | 0 | No | Yes |
| Measuring Type | | No | Yes |
| Measuring Range | | No | Yes |
| Diagnostics | | No | Yes |
| Temperature Unit | | No | Yes |
| Temperature Coefficient | | No | Yes |
| Interference Suppression | | No | Yes |
| Smoothing | | No | Yes |
| Reference Junction | | No | Yes |
| End-of-scan-cycle interrupt | | No | Yes |
| Diagnostic interrupt enable | 1 | Yes | Yes |
| Hardware interrupt enable | | Yes | Yes |
| Reference Temperature | 1 | Yes | Yes |
| High Limit | 1 | Yes | Yes |
| Low Limit | 1 | Yes | Yes |

Note

If you want to enable the diagnostic interrupt in the user program in data record 1, you must enable the diagnosis in data record 0 beforehand using *STEP 7*.

Structure of Data Record 1

The figure below shows the structure of data record 1 for the parameters of the analog input modules.

You enable a parameter by setting the corresponding bit to “1”.

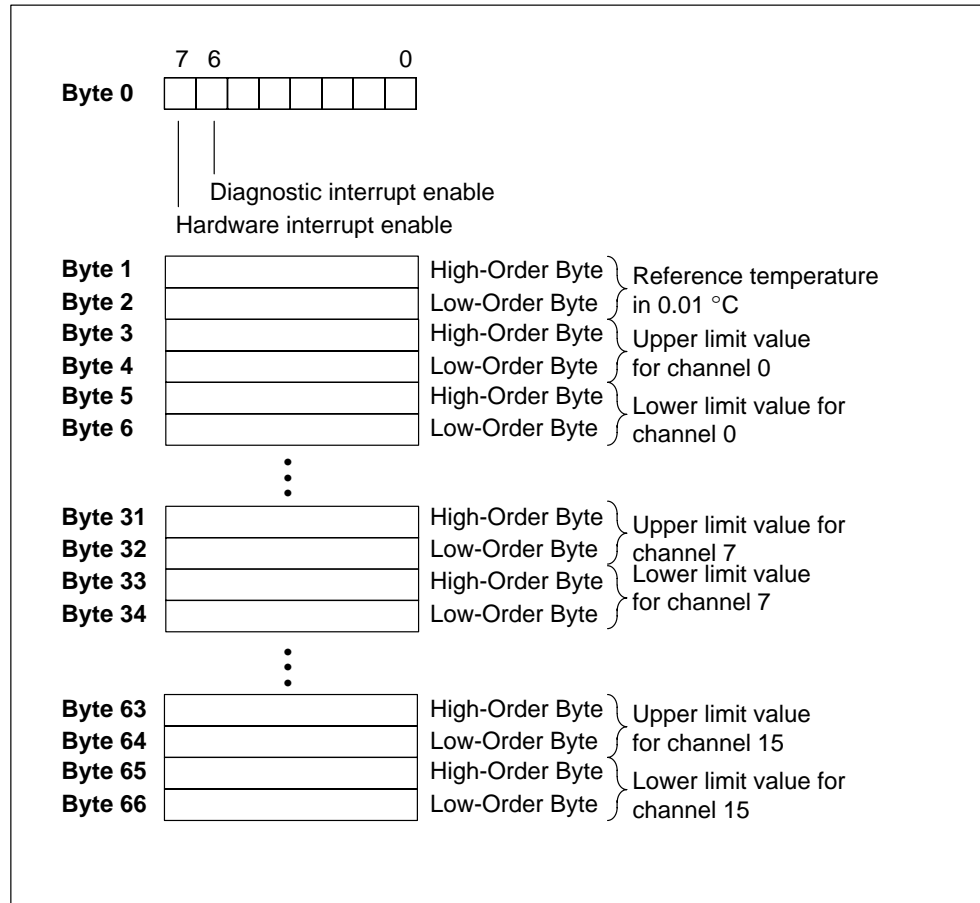

Figure A-5 Data Record 1 for Parameters of the Analog Input Modules

Note

The representation of the limit values and the reference temperature corresponds to the analog value representation (see Chapter 6). Please observe the range limits when setting the limit values.

Diagnostic Data of the Signal Modules

B

Chapter Overview

| Section | Description | Page |
|---------|--|------|
| B.1 | Evaluating the Diagnostic Data of the Signal Modules in the User Program | B-2 |
| B.2 | Structure and Contents of Diagnostic Data Bytes 0 and 1 | B-3 |
| B.3 | Diagnostic Data of the Digital Input Modules as of Byte 2 | B-4 |
| B.4 | Diagnostic Data of the Digital Output Modules as of Byte 2 | B-8 |
| B.5 | Diagnostic Data of the Analog Input Modules as of Byte 2 | B-14 |

B.1 Evaluating the Diagnostic Data of the Signal Modules in the User Program

In This Appendix

This Appendix describes the structure of the diagnostic data in the system data. You must be familiar with this structure if you want to evaluate the diagnostic data of the signal module in the *STEP 7* user program.

Diagnostic Data are Contained in Data Records

The diagnostic data of a module can be up to 43 bytes long and are contained in data records 0 and 1:

- Data record 0 contains 4 bytes of diagnostic data that describe the current status of a programmable controller.
- Data record 1 contains the four bytes of diagnostic data that are also contained in data record 0 **and** as many as 39 bytes of module-specific diagnostic data.

Further Reading

An in-depth description of the principle of evaluating the diagnostic data of signal modules in the user program and a description of the SFCs that can be used for that purpose will be found in the *STEP 7* manuals.

B.2 Structure and Contents of Diagnostic Data Bytes 0 and 1

The structure and contents of the different bytes of the diagnostic data are described below. The following general rule applies: When an error occurs, the bit concerned is set to "1".

Bytes 0 and 1

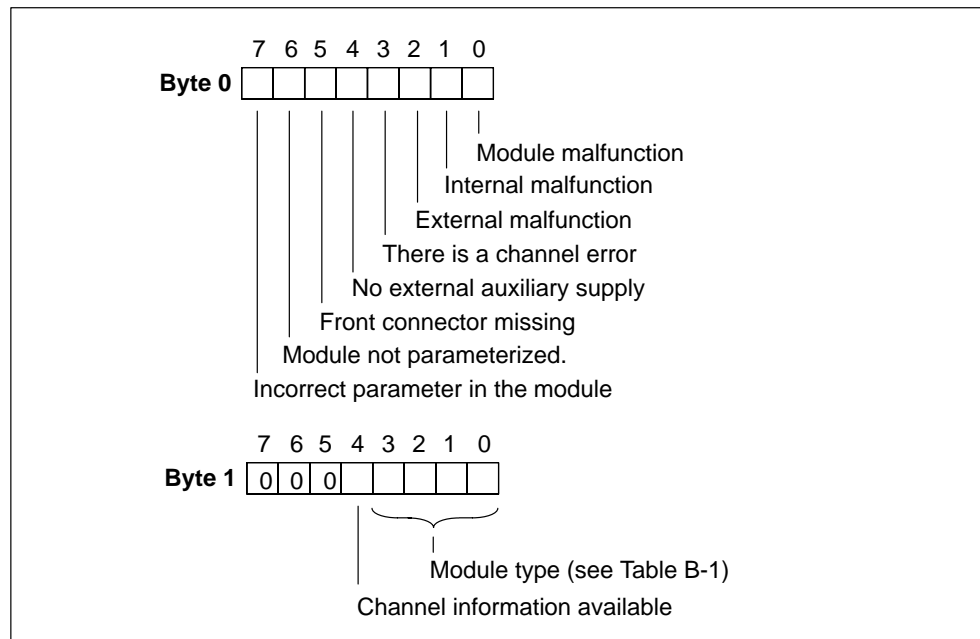

Figure B-1 Bytes 0 and 1 of the Diagnostic Data

Module Types

The following table contains the IDs of the module classes (bits 0 to 3 in byte 1).

Table B-1 Codes of the Module Types

| Code | Module Type |
|------|-----------------|
| 0101 | Analog module |
| 0110 | CPU |
| 1000 | Function module |
| 1100 | CP |
| 1111 | Digital module |

B.3 Diagnostic Data of the Digital Input Modules as of Byte 2

The structure and contents of the different bytes of the diagnostic data for special digital input modules are described below. The following general rule applies: When an error occurs, the bit concerned is set to "1".

You will find a description of possible error causes and appropriate remedies in the section called "Diagnostics of the Modules".

Bytes 2 and 3 of the SM 421; DI 16 × 24 VDC

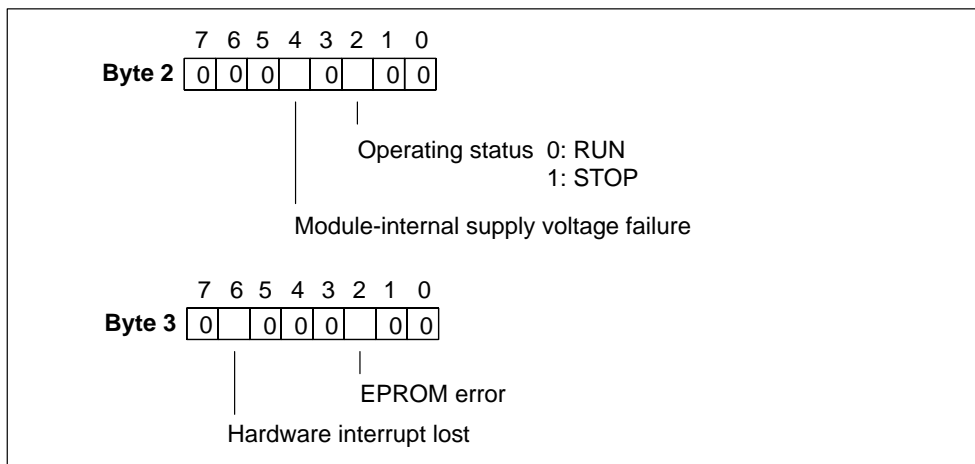

Figure B-2 Bytes 2 and 3 of the Diagnostic Data of the SM 421; DI 16 x 24 VDC

Bytes 4 to 8 of the SM 421; DI 16 × 24 VDC

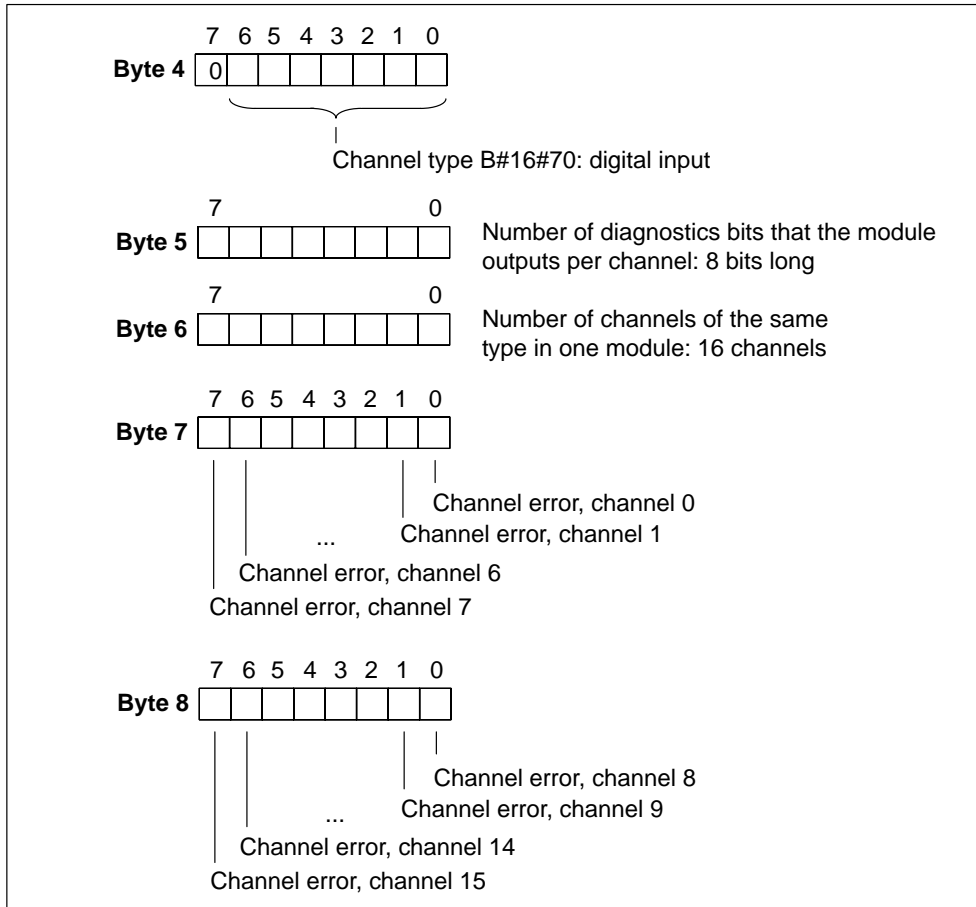

Figure B-3 Bytes 4 to 8 of the Diagnostic Data of the SM 421; DI 16 x 24 VDC

Bytes 9 to 24 of the SM 421; DI 16 × 24 VDC

Data record 1 with bytes 9 to 24 contains the channel-specific diagnostic data. The figure below shows the assignment of the diagnostic byte for a channel of the module.

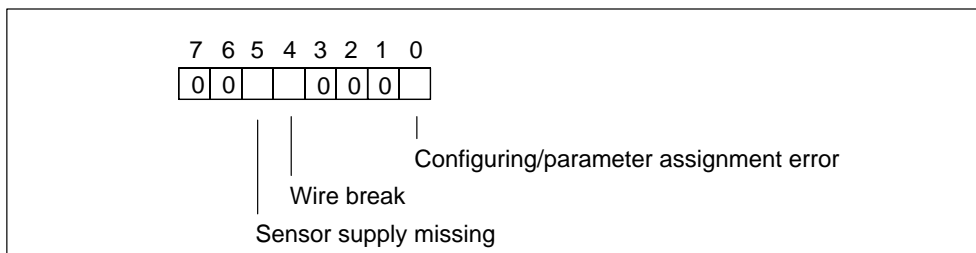

Figure B-4 Diagnostic Byte for a Channel of the SM 421; DI 16 x 24 VDC

Bytes 2 and 3 of the SM 421; DI 16 × 24/60 VUC

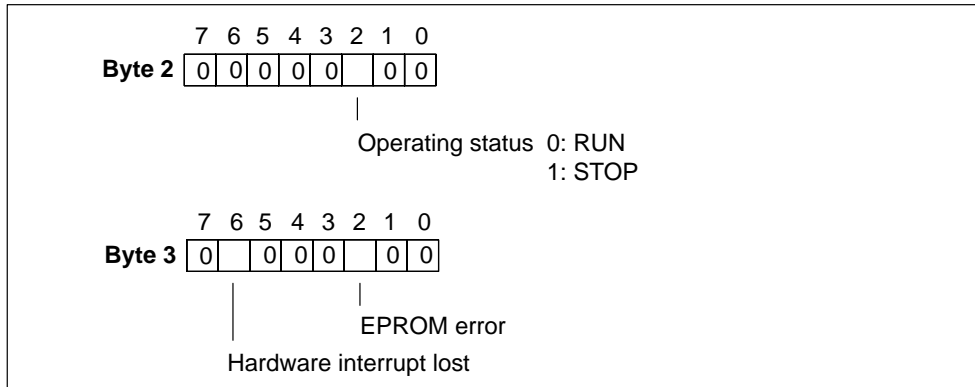

Figure B-5 Bytes 2 and 3 of the Diagnostic Data of the SM 421; DI 16 x 24/60 VUC

Bytes 4 to 8 of the SM 421; DI 16 × 24/60 VUC

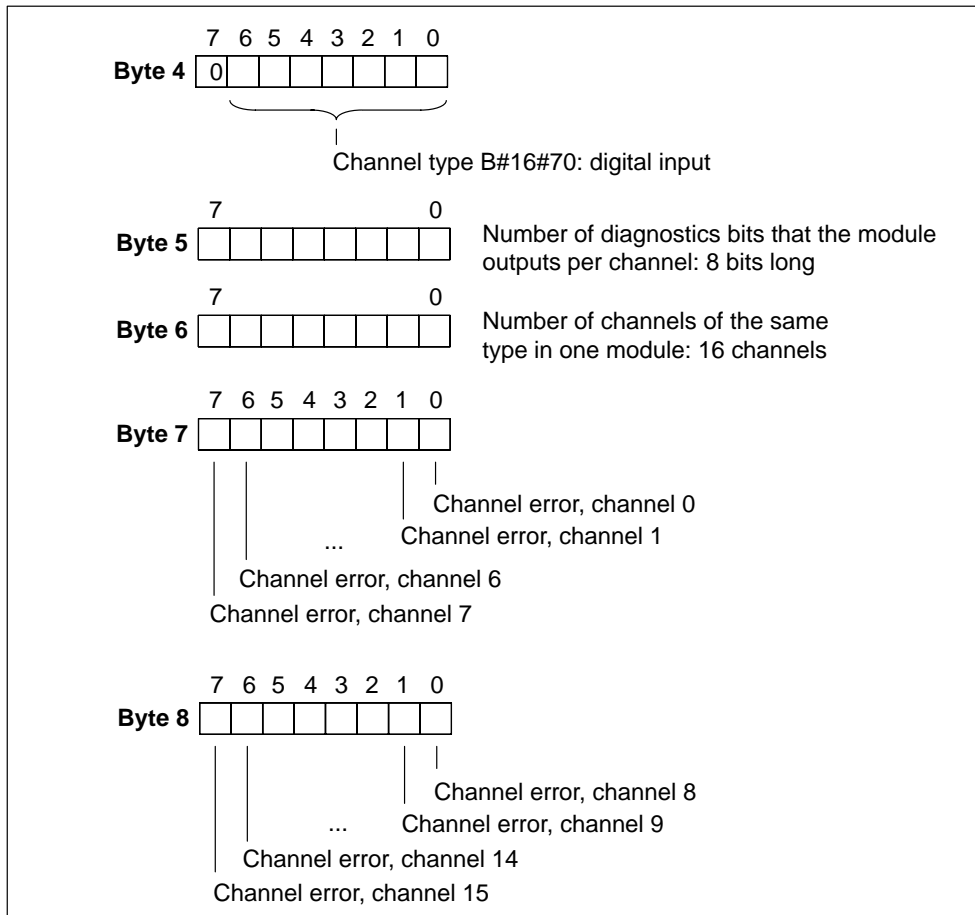

Figure B-6 Bytes 4 to 8 of the Diagnostic Data of the SM 421; DI 16 x 24/60 VUC

Bytes 9 to 24 of the SM 421; DI 16 × 24/60 VUC

Data record 1 with bytes 9 to 24 contains the channel-specific diagnostic data. The figure below shows the assignment of the diagnostic byte for a channel of the module.

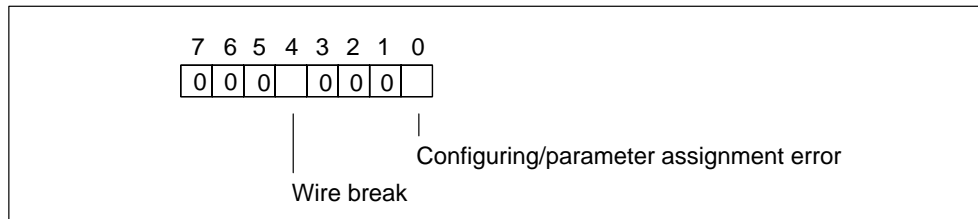

Figure B-7 Diagnostic Byte for a Channel of the SM 421; DI 16 x 24/60 VUC

B.4 Diagnostic Data of the Digital Output Modules as of Byte 2

The structure and contents of the different bytes of the diagnostic data for special digital output modules are described below. The following general rule applies: When an error occurs, the bit concerned is set to "1".

You will find a description of possible error causes and appropriate remedies in the section called on the special module.

Bytes 2 and 3 of the SM 422; DO 16 × 20-125 VDC/1.5 A

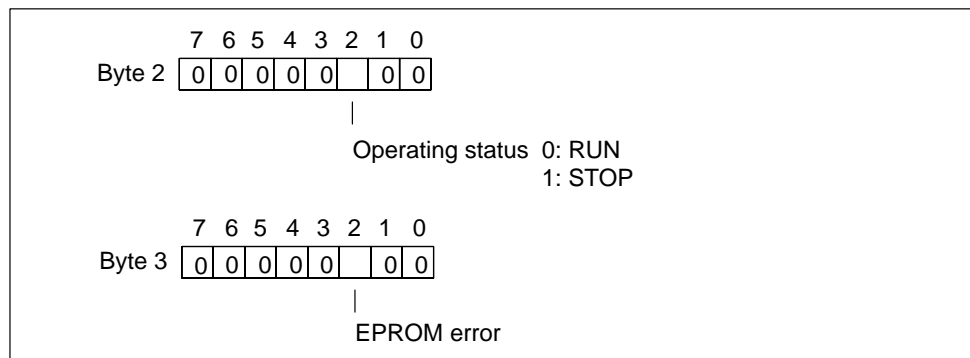

Figure B-8 Bytes 2 and 3 of the Diagnostic Data of the SM 422; DO 16 x 20-125 VDC/1.5 A

Bytes 4 to 8 of the SM 422; DO 16 × 20-125 VDC/1.5 A

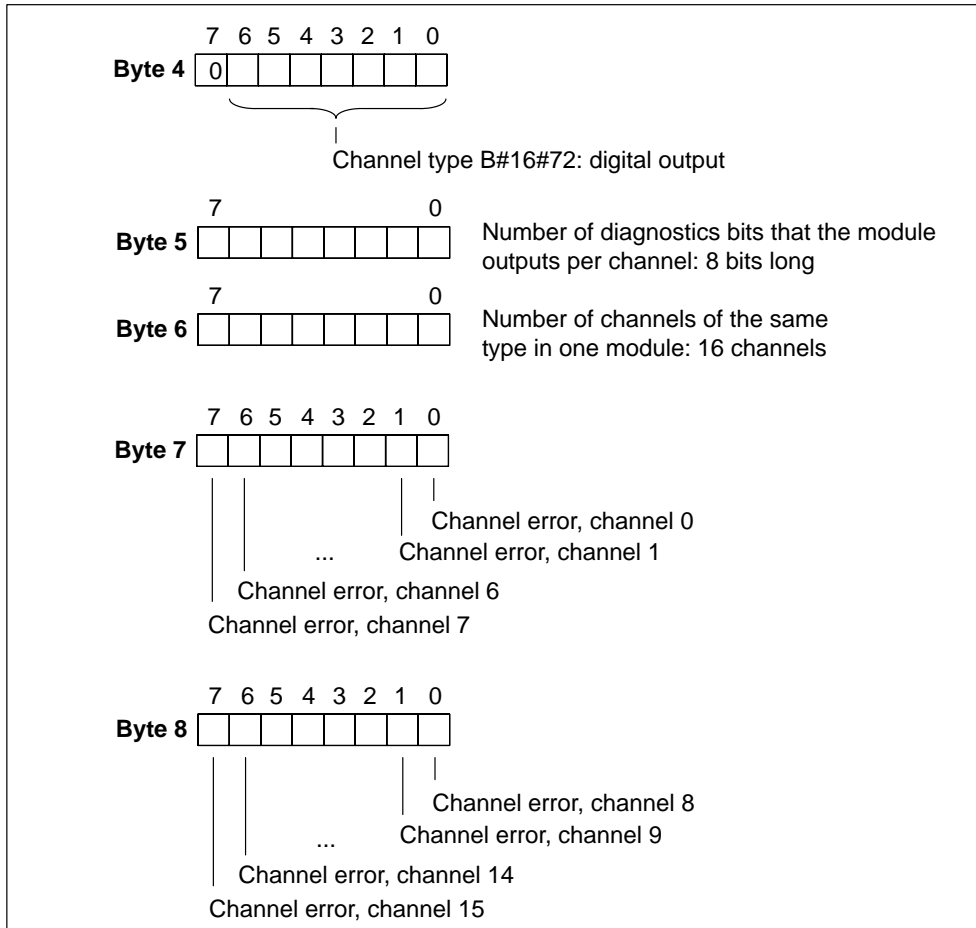

Figure B-9 Bytes 4 to 8 of the Diagnostic Data of the SM 422; DO 16 x 20-125 VDC/1.5 A

Bytes 9 to 24 of the SM 421; DO 16 × 20-125 VDC/1.5 A

Data record 1 with bytes 9 to 24 contains the channel-specific diagnostic data. The figure below shows the assignment of the diagnostic byte for a channel of the module.

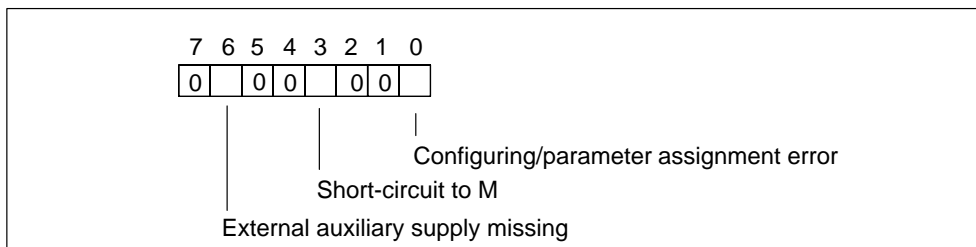

Figure B-10 Diagnostic Byte for a Channel of the SM 422; DO 16 x 20-125 VDC/1.5 A

Bytes 2 and 3 of the SM 422; DO 32 × 24 VDC/0.5 A

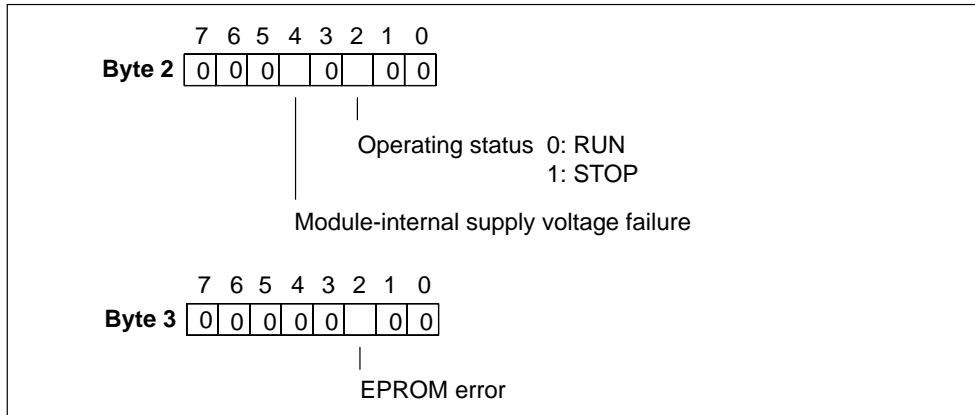

Figure B-11 Bytes 2 and 3 of the Diagnostic Data of the SM 422; DO 32 x 24 VDC/0.5 A

Bytes 4 to 10 of the SM 422; DO 32 × 24 VDC/0.5 A

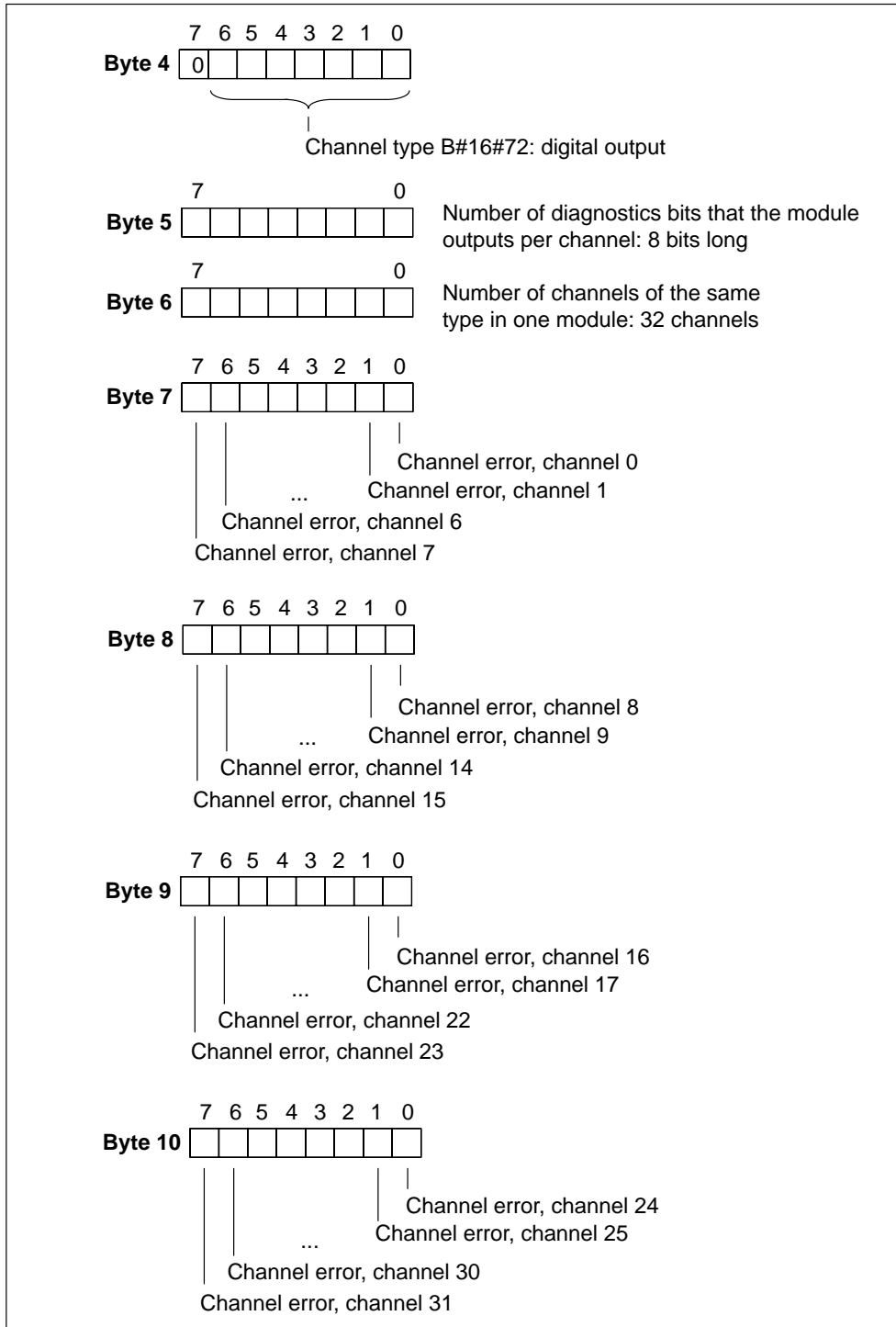

Figure B-12 Bytes 4 to 10 of the Diagnostic Data of the SM 422; DO 32 x 24 VDC/0.5 A

Bytes 11 to 42 of the SM 422; DO 32 × 24 VDC/0.5 A

Data record 1 with bytes 11 to 42 contains the channel-specific diagnostic data. The figure below shows the assignment of the diagnostic byte for a channel of the module.

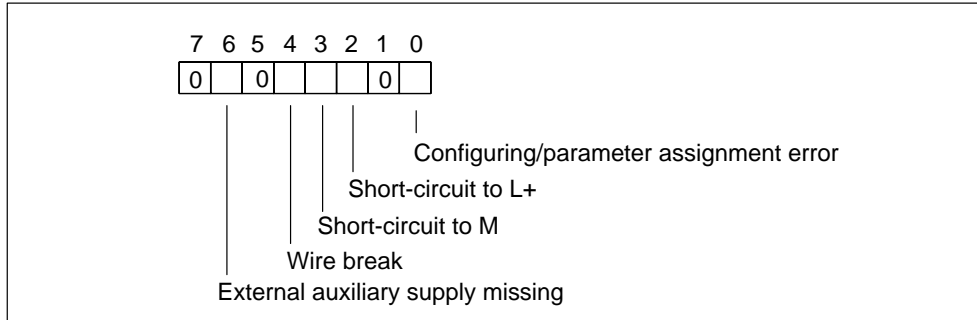

Figure B-13 Diagnostic Byte for a Channel of the SM 422; DO 32 x 24 VDC/0.5 A

Bytes 2 and 3 of the SM 422; DO 16 × 20-120 VAC/2 A

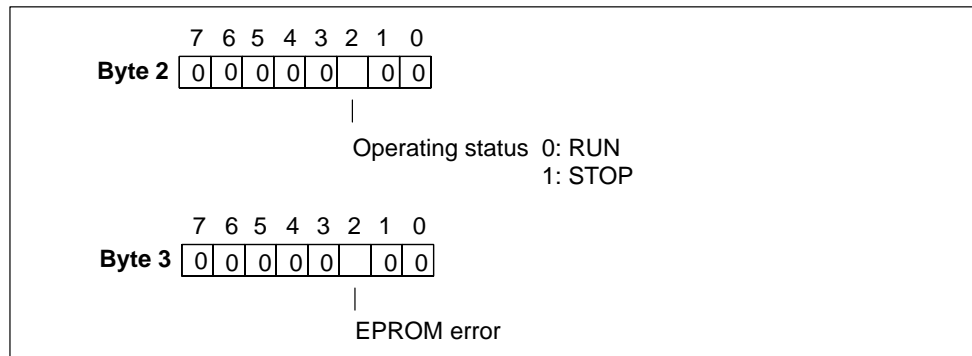

Figure B-14 Bytes 2 and 3 of the Diagnostic Data of the SM 422; DO 16 x 20-120 VAC/2 A

Bytes 4 to 8 of the SM 422; DO 16 × 20-120 VAC/2 A

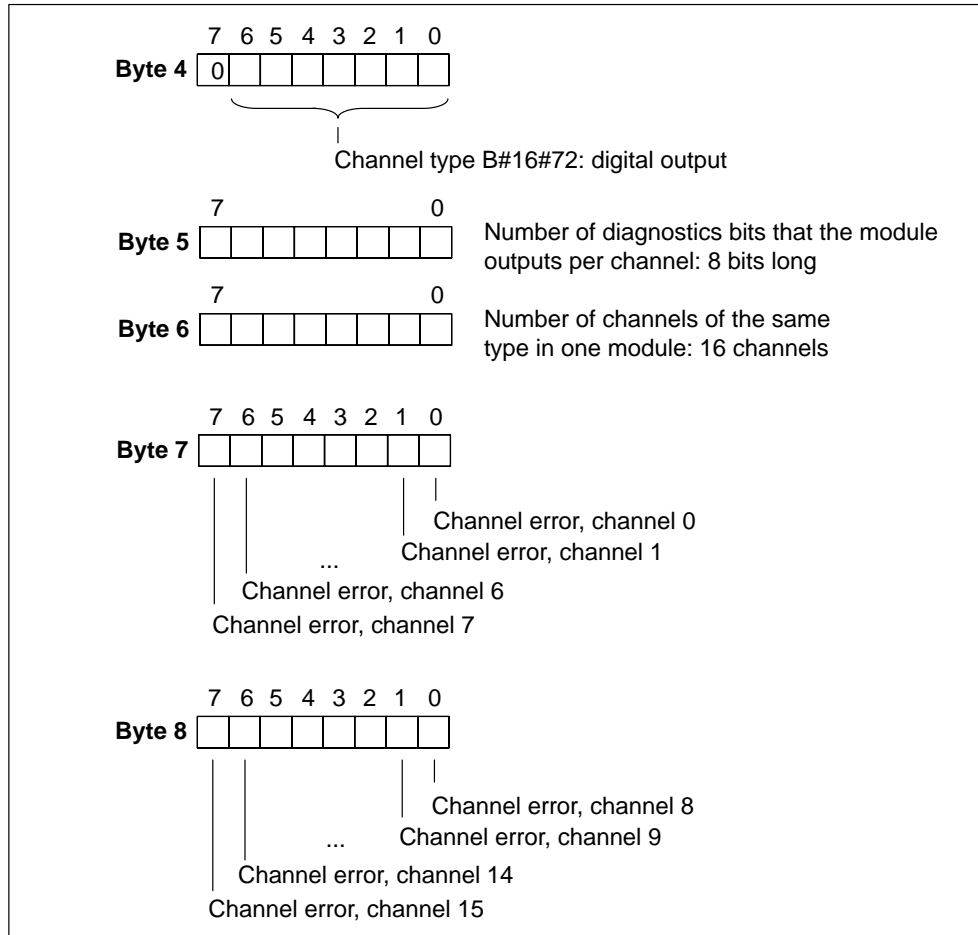

Figure B-15 Bytes 4 to 8 of the Diagnostic Data of the SM 422; DO 16 x 20-120 VAC/2 A

Bytes 9 to 24 of the SM 422; DO 16 × 20-120 VAC/2 A

Data record 1 with bytes 9 to 24 contains the channel-specific diagnostic data. The figure below shows the assignment of the diagnostic byte for a channel of the module.

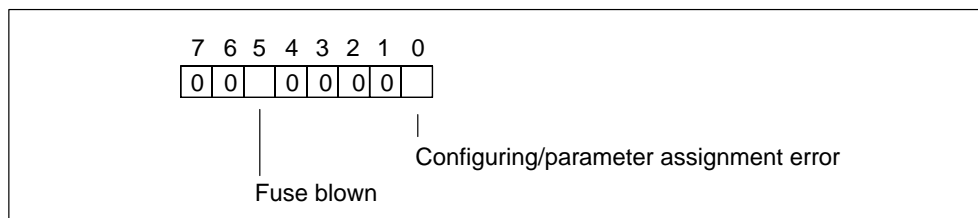

Figure B-16 Diagnostic Byte for a Channel of the SM 422; DO 16 x 20-120 VAC/2 A

B.5 Diagnostic Data of the Analog Input Modules as of Byte 2

The structure and contents of the different bytes of the diagnostic data for the special analog input modules are described below. The following general rule applies: When an error occurs, the bit concerned is set to "1".

You will find a description of possible error causes and appropriate remedies in the section called on the special module.

Bytes 2 and 3 of the SM 431; AI 16 × 16 Bit

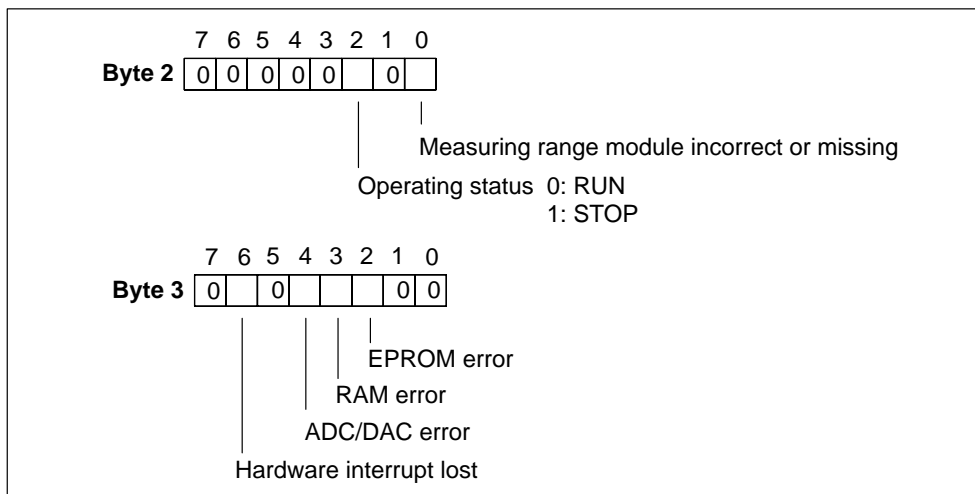

Figure B-17 Bytes 2 and 3 of the Diagnostic Data of the SM 431; AI 16 x 16 Bit

Bytes 4 to 8 of the SM 431; AI 16 × 16 Bit

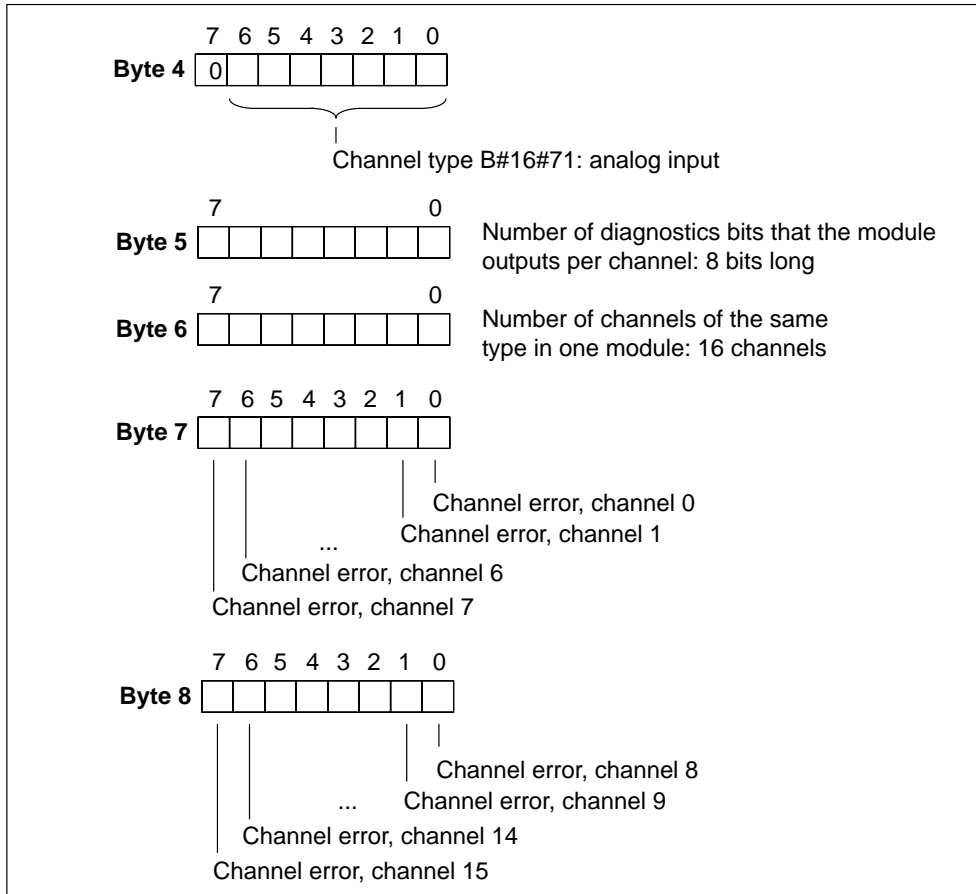

Figure B-18 Bytes 4 to 8 of the Diagnostic Data of the SM 431; AI 16 x 16 Bit

Bytes 9 to 24 of the SM 431; AI 16 x 16 Bit

Data record 1 with bytes 9 to 24 contains the channel-specific diagnostic data. The figure below shows the assignment of the diagnostic byte for a channel of the module.

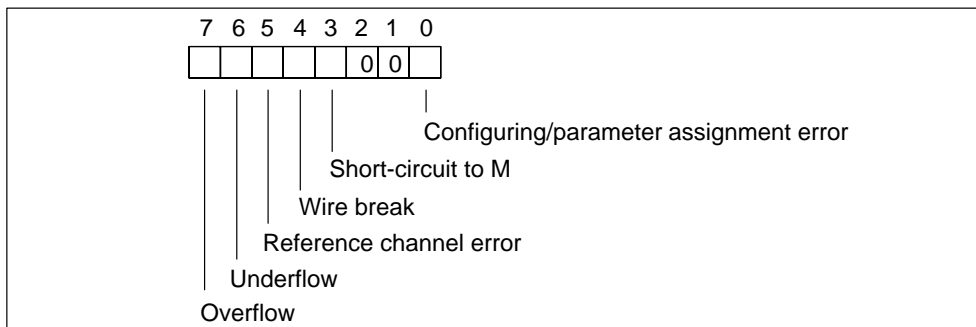

Figure B-19 Diagnostic Byte for a Channel of the SM 431; AI 16 x 16 Bit

Bytes 2 and 3 of the SM 431; AI 8 × RTD × 16 Bit

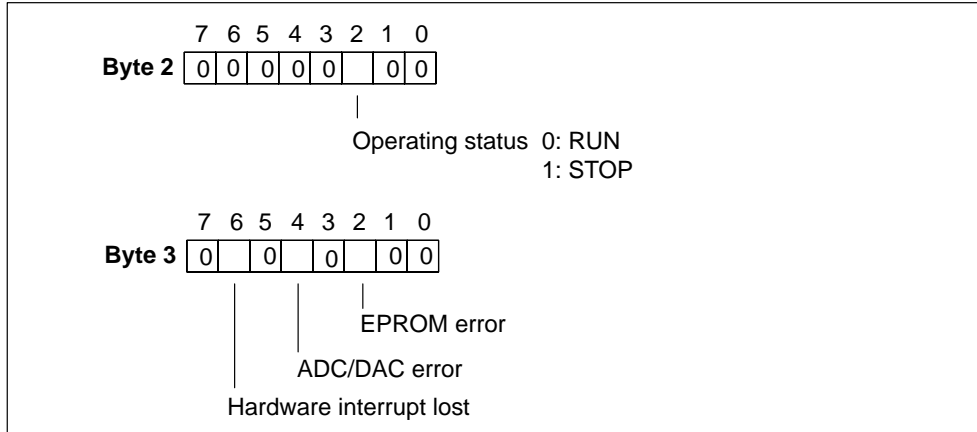

Figure B-20 Bytes 2 and 3 of the Diagnostic Data of the SM 431; AI 8 x RTD x 16 Bit

Bytes 4 to 7 of the SM 431; AI 8 × RTD × 16 Bit

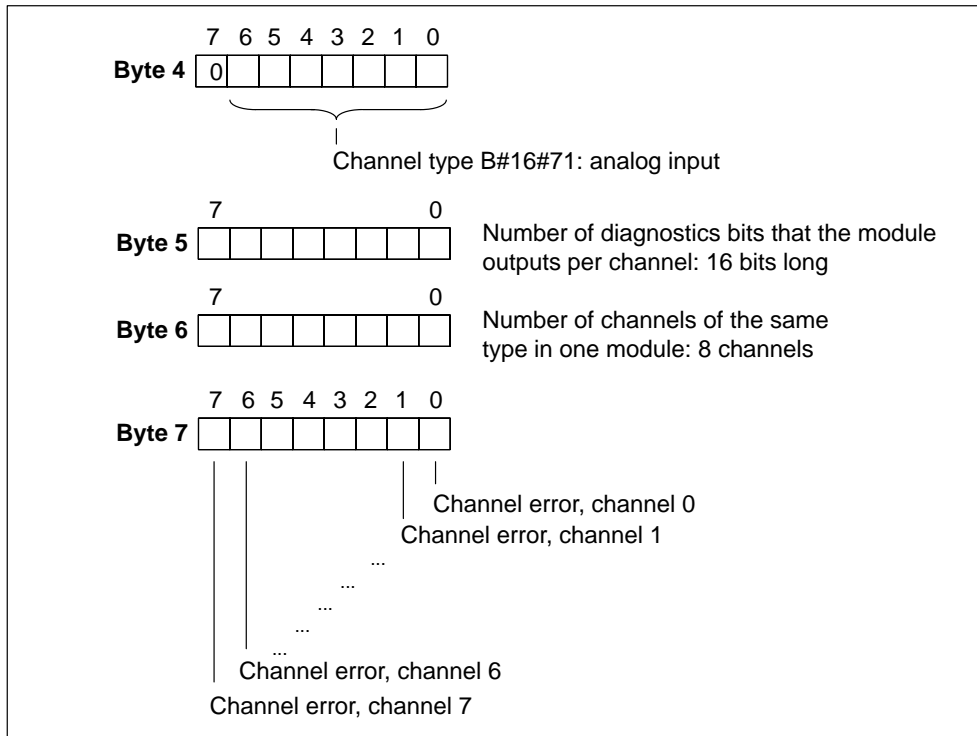

Figure B-21 Bytes 4 to 7 of the Diagnostic Data of the SM 431; AI 8 x RTD x 16 Bit

Bytes 2 and 3 of the SM 431; AI 8 × 16 Bit

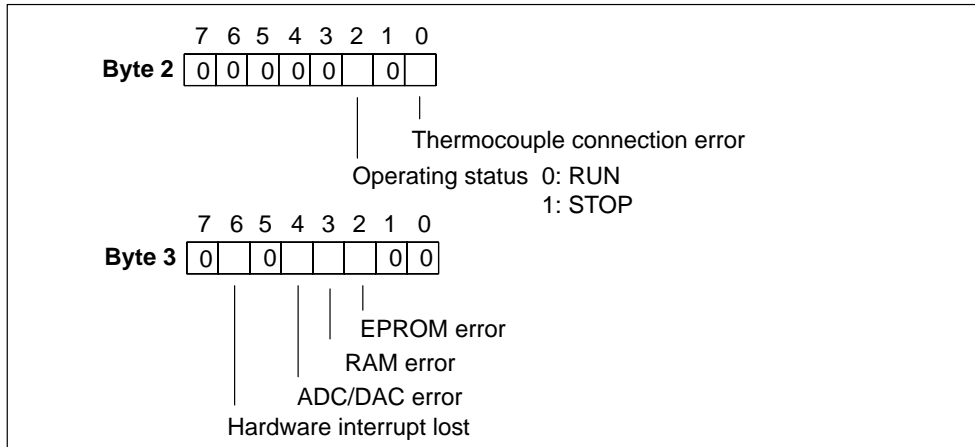

Figure B-24 Bytes 2 and 3 of the Diagnostic Data of the SM 431; AI 8 x 16 Bit

Bytes 4 to 7 of the SM 431; AI 8 × 16 Bit

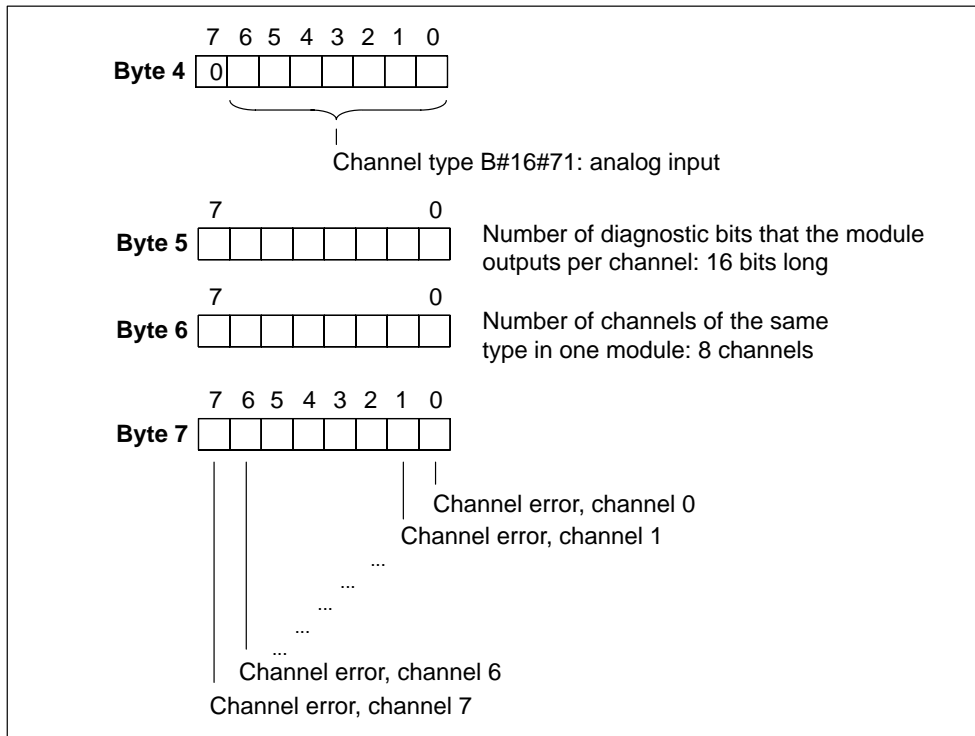

Figure B-25 Bytes 4 to 7 of the Diagnostic Data of the SM 431; AI 8 x 16 Bit

Spare Parts and Accessories

C

Spare Parts and Accessories

| | |
|---|--------------------|
| For Racks | |
| Number wheel for slot labeling | C79165-Z1523-A22 |
| Spare slot covers (qty 10) | 6ES7490-1AA00-0AA0 |
| For Power Supplies | |
| Spare connector for PS 405 (DC) | 6ES7490-0AA00-0AA0 |
| Spare connector for PS 407 (AC) | 6ES7490-0AB00-0AA0 |
| Backup battery | 6ES7971-0BA00 |
| For CPUs | |
| Key for CPU mode selector switch | 6ES7911-0AA00-0AA0 |
| 2 Mbyte memory submodule | 6ES7911-0AA00-0AA0 |
| 4 Mbyte memory submodule | 6ES7911-0AA00-0AA0 |
| For Digital Modules/Analog Modules | |
| Cover foil (10 x) for labeling strips of the SMs | 6ES7492-2XX00-0AA0 |
| Cover flap for fuse receptacle on the AC modules | 6ES7422-0XX00-7AA0 |
| Measuring range module for analog modules | 6ES7974-0AA00-0AA0 |
| Front connector screw-type connection | 6ES7492-1AL00-0AA0 |
| Front connector spring connection | 6ES7492-1BL00-0AA0 |
| Front connector crimp connection | 6ES7492-1CL00-0AA0 |
| Crimping tool for crimp contacts | 6XX3 071 |
| Crimp contacts (package of 250) | 6XX3 070 |
| Extraction tool for crimp contacts | 6ES5 497-8MA11 |
| Fuses, 8 A, quick blow | |
| • Wickmann | 194-1800-0 |
| • Schurter | SP001.1013 |
| • Littelfuse | 217.008 |
| Labeling sheet for the front connector, petrol blue | 6ES7492-2AX00-0AA0 |
| Labeling sheet for the front connector, beige | 6ES7492-2BX00-0AA0 |
| Labeling sheet for the front connector, yellow | 6ES7492-2CX00-0AA0 |
| Labeling sheet for the front connector, red | 6ES7492-2DX00-0AA0 |

| | |
|--|---|
| For IMs | |
| Terminating connector for IM 461-0 | 6ES7461-0AA00-7AA0 |
| Terminating connector for IM 461-1 | 6ES7461-1AA00-7AA0 |
| Terminating connector for IM 461-3 | 6ES7461-3AA00-7AA0 |
| IM 463-2, send IM, 600 m to IM 314 of the S5 | 6ES7463-2AA00-0AA0 |
| IM cable with communication bus, 0.75 m | 6ES7468-1AH50-0AA0 |
| IM cable with communication bus, 1.5 m | 6ES7468-1BB50-0AA0 |
| IM cable with communication bus, 5 m | 6ES7468-1BF00-0AA0 |
| IM cable with communication bus, 10 m | 6ES7468-1CB00-0AA0 |
| IM cable with communication bus, 25 m | 6ES7468-1CC50-0AA0 |
| IM cable with communication bus, 50 m | 6ES7468-1CF00-0AA0 |
| IM cable with communication bus, 100 m | 6ES7468-1DB00-0AA0 |
| IM cable with current transmission, 0.75 m | 6ES7468-3AH50-0AA0 |
| IM cable with current transmission, 1.5 m | 6ES7468-3BB50-0AA0 |
| For CP 441 | |
| IF963-RS232 interface submodule | 6ES7961-1AA00-0AA0 |
| IF963-TTY interface submodule | 6ES7961-2AA00-0AA0 |
| IF963-X27 interface submodule | 6ES7961-3AA00-0AA0 |
| IF module L2-DP | 6ES7964-2AA00-0AB0 |
| For Interfacing / Networking | |
| RS 485 repeater | 6ES7972-0AA00-0XA0 |
| DIN rail | 6ES5710-8MA... |
| PROFIBUS bus cable | 6XV1830-0BH10 6XV1830-3BH10 |
| PROFIBUS internal cable | 6XV1830-0BH10 |
| PROFIBUS grounding cable | 6XV1830-3BH10 |
| PROFIBUS bus connector without PG socket | 6ES7972-0BA00-0XA0 |
| PROFIBUS bus connector with PG socket | 6ES7972-0BB10-0XA0 |
| PROFIBUS bus connector without PG socket for CPU 417 | 6ES7972-0BA40-0X40 |
| PROFIBUS bus connector with PG socket for CPU 417 | 6ES7972-0BB40-0X40 |
| PROFIBUS RS 485 bus terminal | 6GK1500-0AA00 6GK1500-0AB00 6GK1500-0DA00 |
| PG cable, short | 6ES7901-0BF00-0AA0 |
| PG 705 cable | 6ES7705-0AA00-7BA0 |
| PC/MPI cable (5 m) | 6ES7901-2BF00-0AA0 |
| PC/MPI cable (16 m) | 6ES7901-2CB60-0AA0 |
| For Fan Subassembly | |
| Spare fan for fan subassembly | 6ES7408-1TA00-6AA0 |
| Filters (qty 10) for fan subassembly | 6ES7408-1TA00-7AA0 |
| Monitoring PCB for fan subassembly | 6ES7408-1TX00-6XA0 |
| Power supply PCB for fan subassembly | 6ES7408-1XX00-6XA0 |
| Cabinets | |
| Cabinet 2200 x 800 x 400 with extension set for SIMATIC S7-400 | 8 MC 2281-7FC11-8DA1 |
| Extension set for SIMATIC S7-400 | 8 MC 1605-0BS70-0AA0 |

| Cables | |
|--|--|
| Connecting cables for printers with <ul style="list-style-type: none"> Serial port (COM, 10 m) Parallel port (Centronics) | 9AB4173-2BN10-0CA0 6AP1901-0AL00 |
| Connecting cable for interface module <ul style="list-style-type: none"> 1 m 2.5 m 5 m 10 m | 6ES7368-3BB00-0AA0 6ES7368-3BC00-0AA0 6ES7368-3BF00-0AA0 6ES7368-3CB00-0AA0 |
| V.24 cable | 9AB4173-2BN10-0CA0 |
| Connector housing, gray <ul style="list-style-type: none"> 9-pin 15-pin 25-pin Connector housing, black <ul style="list-style-type: none"> 9-pin 15-pin 25-pin | V42254-A6000-G109 V42254-A6000-G115 V42254-A6000-G125 V42254-A6001-G309 V42254-A6001-G315 V42254-A6001-G325 |

Memory Submodules for M7-400

The following table lists the memory submodules that can be used in the CPU 486-3 and CPU 488-3.

| Product | Description | Order No. |
|----------------|---|--------------------|
| MEM 478 | Memory submodule for main memory DRAM 2 x 8 Mbytes/3.3 V | 6ES7791-0EP00-0XA0 |

In the CPUs the memory submodules must always be used in pairs.

Spare Parts for M7-400 Modules

| | |
|--|--|
| Memory cards <ul style="list-style-type: none"> Flash EPROM, 1 Mbyte Flash EPROM, 2 Mbytes Flash EPROM, 4 Mbytes Flash EPROM, 8 Mbytes Flash EPROM, 16 Mbytes | 6ES7952-1KK00-0AA0 6ES7952-1KL00-0AA0 6ES7952-1KM00-0AA0 6ES7952-1KP00-0AA0 6ES7952-1KS00-0AA0 |
| 10 cover foils for SM labeling strips | 6ES7492-2XX00-0AA0 |
| Cover flap for fuse receptacle, AC-SM | 6ES7422-0XX00-7AA0 |
| 12 spare submodule covers | 6ES7398-0BA00-0AA0 |
| 6 connecting clips | 6ES7498-6BA00-0AA0 |

Guidelines for Handling Electrostatic Sensitive Devices (ESD)

D

Introduction

In this appendix, we explain

- what is meant by “electrostatic sensitive devices”
- the precautions you must observe when handling and working with electrostatic sensitive devices.

Chapter Overview

This chapter contains the following sections on electrostatic sensitive devices:

| Section | Description | Page |
|---------|--|------|
| D.1 | What is ESD? | D-2 |
| D.2 | Electrostatic Charging of Persons | D-3 |
| D.3 | General Protective Measures Against Electrostatic Discharge Damage | D-4 |

D.1 What is ESD?

Definition

All electronic modules are equipped with large-scale integrated ICs or components. Due to their design, these electronic elements are very sensitive to overvoltages and thus to any electrostatic discharge.

These **E**lectrostatic **S**ensitive **D**evelopments are commonly referred to by the abbreviation **ESD**.

Electrostatic sensitive devices are labelled with the following symbol:

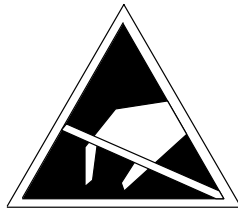

Caution

Electrostatic sensitive devices are subject to voltages that are far below the voltage values that can still be perceived by human beings. These voltages are present if you touch a component or the electrical connections of a module without previously being electrostatically discharged. In most cases, the damage caused by an overvoltage is not immediately noticeable and results in total damage only after a prolonged period of operation.

D.2 Electrostatic Charging of Persons

Charging

Every person with a non-conductive connection to the electrical potential of its surroundings can be charged electrostatically.

Figure D-1 shows you the maximum values for electrostatic voltages which can build up on a person coming into contact with the materials indicated in the figure. These values are in conformity with the specifications of IEC 61000-4-2.

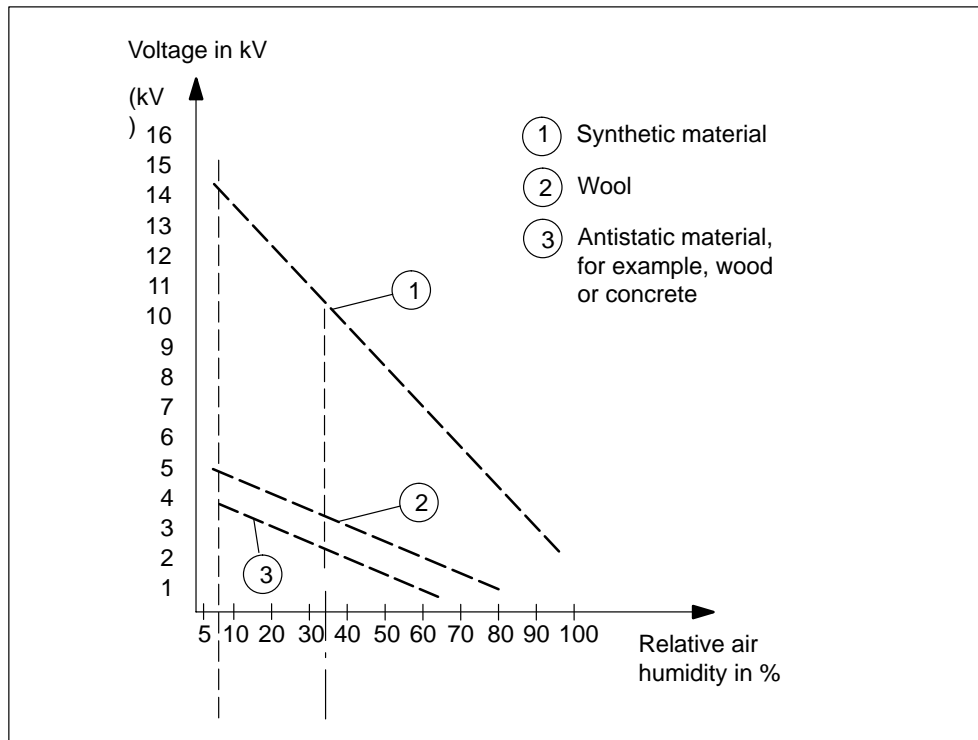

Figure D-1 Electrostatic Voltages which Can Build up on a Person

D.3 General Protective Measures Against Electrostatic Discharge Damage

Ensure Sufficient Grounding

Make sure that the personnel, working surfaces and packaging are sufficiently grounded when handling electrostatic sensitive devices. You thus avoid electrostatic charging.

Avoid Direct Contact

You should touch electrostatic sensitive devices only if it is unavoidable (for example, during maintenance work). Hold modules without touching the pins of components or printed conductors. In this way, the discharged energy cannot affect the sensitive devices.

If you have to carry out measurements on a module, you must discharge your body before you start the measurement by touching grounded metallic parts. Use grounded measuring devices only.

E

List of Abbreviations

| Abbreviation | Explanation |
|-----------------|---|
| AC | Alternating current |
| ADC | Analog to digital converter |
| AI | Analog input |
| AO | Analog output |
| AS | Automation system |
| BAF | Battery failure |
| BUSF1; BUSF2 | LED – bus failure on the MPI/Profibus DP interface 1 or 2 |
| CD | Central device |
| CH | Channel |
| COMP | Compensating terminal |
| CP | Communications processor |
| CR | Central rack |
| CPU | Central processing unit of a PLC |
| DAC | Digital-to-analog converter |
| DB | Data block |
| DC | Direct current |
| DI | Digital input |
| DO | Digital output |
| EMC | Electromagnetic compatibility |
| EEPROM | Electrically erasable programmable read-only memory |
| EPROM | Erasable programmable read-only memory |
| ER | Expansion rack |
| ES | Encoder supply |
| ESD | Electrostatic sensitive devices |
| EWS | Apply substitute value |
| EXM | Extension module |
| EXTF | Error LED “external fault” |
| FB | Function block |
| FBD | Function block diagram |

| | |
|--------------|---|
| FC | Function |
| FEPRM | Flash erasable programmable read only memory |
| FM | Function module |
| FOC | Fiber-optic cable |
| FRCE | Force |
| GD | Global data communication |
| I_C | Constant-current lead |
| ID | Input delay |
| IFM1F; IFM2F | LED error at interface module 1/2 |
| IM | Interface module |
| INTF | Error LED "internal fault" |
| IP | Intelligent periphery |
| L+ | Terminal for 24 VDC supply voltage |
| LAD | Ladder logic diagram |
| LWH | Hold last valid value |
| M | Ground terminal |
| M+ | Measuring lead (positive) |
| M- | Measuring lead (negative) |
| M_{ANA} | Reference potential of the analog measuring circuit |
| MPI | Multipoint interface |
| MRES | Master reset |
| MSM | Mass storage module |
| MSTR | Master |
| OB | Organization block |
| OP | Operator panel |
| OS | Operator system |
| PIQ | Process-image output table |
| PII | Process-image input table |
| PLC | Programmable logic controller |
| PG | Programming device |
| PS | Power supply |
| Q_I | Analog output current |
| Q_V | Analog output voltage |
| RAM | Random access memory |
| REDF | Redundancy fault |
| R_L | Load impedance |

| | |
|------------------|--|
| S + | Sensor lead (positive) |
| S – | Sensor lead (negative) |
| SCL | Structured control language |
| SP | Sensor power |
| SF | “Group error” LED |
| SFB | System function block |
| SFC | System function |
| SM | Signal module |
| SSI | Synchronous serial interface |
| SSL | System status list |
| STL | Statement list |
| TD | Text display |
| TR | Transducer |
| U _{CM} | Common mode voltage |
| U _H | Auxiliary voltage |
| U _{iso} | Potential difference between M _{ANA} and local ground |
| UC | Universal current |
| UR | Universal rack |
| USR | USR |
| V _s | Sensor voltage |
| VZ | Sign |

Glossary

Address

An address denotes a specific operand or address area; examples of this are: input I 12.1; memory word MW 25; data block DB 3.

Aggregate current

Sum of the currents of all output channels on a digital output module.

Backplane bus

The backplane bus is a serial data bus that is used by the modules to communicate with each other and to supply them with the voltage they require. The interconnection of the modules is established by the bus connector.

Backup battery

The backup battery ensures that the → user program is stored in a powerfail-proof manner in the → CPU, and that defined data areas and memory markers, timers and counters are kept → retentively.

Backup voltage, external

You can obtain the same kind of backup if you apply backup voltage to the "EXT.-BATT." socket of the CPU (DC voltage between 5 V and 15 V) as you can with a backup battery.

External backup voltage is required if you want to replace a power supply module and to provide a backup supply while the user program and data (for example, memory markers, timers, counters, system data, integrated clock) stored in RAM are to be buffered for the time it takes to replace the module.

Bus

A bus is a transmission medium that interconnects several nodes. Data transmission can be serial or parallel, and be performed over electric conductors or fiber-optic cables.

Bus connector

A physical connection between the bus nodes and the bus cable.

Bus segment

A bus segment is a self-contained section of a serial bus system. Bus segments are interconnected by means of → repeaters.

Central controller

An S7-400 consists of a central controller (CC) that can be allocated expansion units (EU), as required. The central controller is the mounting rack that contains the → CPU.

Central processing unit

→ CPU

Cold restart

→ Restart of the programmable controller and its user program, after all the dynamic data (variables of the input/output image, internal registers, timers, counters, etc. and the corresponding program sections) have been reset to a specified value.

A cold restart can be automatically triggered, such as after a power failure or loss of information in dynamic memory sections, etc., or manually by pressing the reset key.

Common mode voltage

A voltage that is common to all inputs/outputs of a group and is measured between this group and any reference point (usually to ground).

Communication load

This is the load on the cyclic program scanning of a CPU caused by communication operations (for example, via → PROFIBUS DP).

To prevent communication operations overloading cyclic program scanning, you can set the maximum permissible load that communication can place on the scan cycle by parameter assignment in *STEP 7*.

Communication processor

Programmable module for communication tasks, such as networking, point-to-point connection.

Comparison point

Parameter in *STEP 7* for analog input modules. Using this parameter, you can determine the reference junction (the point where the temperature is known) when thermocouples are used. The following can be reference junctions: resistance thermometer on channel 0 of the module; → compensating box, → reference temperature.

Compensating box

Compensating boxes can be used for measuring temperatures with thermocouples on analog input modules. The compensating box is a compensation circuit for compensating temperature fluctuations at the → reference junction.

Configure

Select and put together different components on a programmable controller and install the requisite software (for example, operating system on M7 automation computer) and adapt to the specific use (for example, by assigning parameters to the modules).

CP

→ Communication processor

CPU

The CPU (central processing unit) is a CPU module of the → programmable controller that stores and runs the user program. It contains the operating system, memory, processing unit and communication interface.

Data block

Data blocks (DB) are data areas in the user program that contain user data. Global data blocks can be accessed by all code blocks, whereas instance data blocks are assigned to a specific FB call.

Data, static

Static data is data that can only be used within a → function block. The data is saved in an instance data block belonging to the function block. The data stored in this way is retained until the next function block call.

Data, temporary

Temporary data are → local data of a block that are stored in the L stack during execution of a block and that are no longer available after execution.

Declaration

Assigning variables (parameters or local data of a block, for example) with a name, data type, comment, etc.

Default setting

The default setting is a sensible basic setting that is used whenever no other value is used.

Destination CPU for interrupt

Parameter in *STEP 7*. If several CPUs are installed, the user can use this parameter to select the destination CPU for hardware and diagnostic interrupts.

Diagnostic buffer

The diagnostic buffer is a buffered memory area in the CPU in which the diagnostic events are stored in the order in which they occur.
For troubleshooting, the user can read out the exact error cause in *STEP 7* (PLC -> Module Information) from the diagnostic buffer.

Diagnostic data

All the diagnostic events that occur are collected in the CPU and entered in the → diagnostic buffer. If there is an error OB, it is started.

Diagnostic interrupt

Modules with diagnostics capability report system errors to the → CPU by means of diagnostic interrupts. The operating system of the CPU calls OB 82 in the course of a diagnostic interrupt.

Diagnostics

Generic term for → system diagnostics, process error diagnostics and user-defined diagnostics.

Direct access

This is the direct accessing of the CPU by means of the → I/O bus to modules, bypassing the → process image.

Direct communication

Direct communication involves assigning local input address areas of an intelligent DP slave (for example, CPU 315-2 with PROFIBUS DP connection) or of a DP master to the input address areas of a PROFIBUS DP partner. The intelligent DP slave or DP master receives the input data that the PROFIBUS DP partner sends to its DP master via these assigned input address areas.

DP master

A node with a master function in the PROFIBUS DP. A master that behaves in accordance with the EN 50170 with the DP protocol is a DP master. The bus access right (token) is only passed amongst masters. The slaves, in this case DP slaves, can only respond on the request of a master. The following distinctions are made:

DP master (class 1): executes the user data communication with the DP slaves assigned to it.

DP master (class 2): provides services such as: reading of the input/output data, diagnostics, global control.

DP slave

A → slave that is operated on the PROFIBUS bus system with the PROFIBUS DP protocol is called a DP slave.

Edge, falling

Signal status change from 1 to 0

Edge, rising

Signal status change from 0 to 1

EEPROM

Electrically erasable programmable read-only memory

EPROM

Erasable programmable read-only memory

Equidistance

Equidistance is a DP bus cycle that is accurate to a few μs and can be configured in *STEP 7*.

Equipotential bonding

An electrical connection (equipotential bonding conductor) that brings the bodies of electrical resources and foreign conductive bodies to an identical or approximately identical potential in order to avoid interfering or hazardous voltages between these bodies.

External load memory

→ Memory card

FB

→ Function block

FC

→ Function

FEPROM

In their ability to retain data in the event of a power failure (even without a backup battery), FEPROMs (flash erasable programmable read only memories) are the equivalent of the electrically erasable → EEPROMS, but can be erased considerably more quickly.

Fiber-optic cable

A fiber-optic cable is a transmission medium made of glass fiber or plastic. Fiber-optic cables are resistant to electromagnetic faults and they make fast data transfer rates possible.

Force

The "Force" function overwrites a variable (for example, memory marker, output) with a value defined by the user.

At the same time, the variable is assigned write protection so that this value cannot be modified from any point (including from the *STEP 7* user program). The value is retained after the programming device is disconnected.

Write protection is not canceled until the "Unforce" function is called and the variable is written again with the value defined by the user program.

During commissioning, for example, the "Force" function allows certain outputs to be set to the "ON" state for any length of time even if the logic operations of the user program are not fulfilled (for example, because inputs are not wired).

FREEZE

Control command. The inputs of the → DP slaves are frozen to the current value.

Function

A function (FC) in accordance with IEC 1131-3 is a → code block **without** → static data. A function allows parameters to be passed in the user program. Functions are therefore suitable for programming complex functions, such as calculations that are frequently repeated.

Functional grounding

Grounding which has the sole purpose of safeguarding the intended function of the electrical equipment. Functional grounding short-circuits interference voltage that would otherwise have an impermissible impact on the equipment.

Function block

A function block (FB) in accordance with IEC 1131-3 is a → code block **with** → static data. Because an FB has a memory, its parameters (outputs, for example) can be accessed from any position in the user program.

Fuse blown

Parameter in *STEP 7* for digital output modules. When the parameter is enabled, the failure of one or more fuses is detected by the module. With corresponding parameter assignment, a → diagnostic interrupt is triggered.

Global data

Global data are data that can be addressed from any → code block (FC, FB, OB). In detail, this refers to bit memories (M), inputs (I), outputs (Q), timers, counters and data blocks (DB). Absolute or symbolic access is possible to global data.

Global data communication

Global data communication is a method of transferring → global data between CPUs.

Ground

The ground is the total number of all the interconnected inactive parts of a device that cannot take on a hazardous voltage in the event of a fault.

Ground

The conductive ground whose electric potential can be set to zero at any point. In the proximity of grounding electrodes, the ground can have a potential other than zero. The term "reference ground" is frequently used to describe such circumstances.

Ground, to

To ground means to connect an electrically conductive part via a grounding system to the grounding electrode (one or more conductive parts having a very good contact to ground).

Hardware interrupt

A hardware interrupt is triggered by interrupt-triggering modules in response to a particular event in the process (limit value violation; the module has completed the cyclic change of its channels).

The hardware interrupt is reported to the CPU. In accordance with the priority of this interrupt, the → organization block assigned to it is processed.

Input delay

Parameter in *STEP 7* for digital input modules. The input delay is used to suppress injected interference. Interfering pulses from 0 ms to the set input delay are suppressed.

The set input delay is subject to a tolerance that can be obtained from the technical specifications of the module. A high input delay suppresses long interfering pulses, whereas a low input delay suppresses short ones.

The permissible input delay depends on the length of the cable between the encoder and the module. For example, a high input delay has to be set for long unshielded supply conductors to the encoder (longer than 100m).

Integration time

The integration time is the inverse value of the → interference frequency suppression in ms.

Interface, multipoint

→ MPI

Interference frequency suppression

Parameter in *STEP 7* for analog input modules. The frequency of the AC network can interfere with the measured value, especially with measurements in low voltage ranges and with thermocouples. This parameter is used by the user to specify the prevailing line frequency on his system.

Interrupt

The SIMATIC S7 is familiar with 28 different run-time level, which govern running of the user program. These run-time levels include interrupts such as hardware interrupts, among other things. When an interrupt occurs, the operating system automatically calls an assigned organization block in which the user can program the reaction he wants (for example, in an FB).

Interrupt, diagnostic

→ Diagnostic Interrupt

Interrupt, end-of-scan-cycle

→ Hardwareinterrupt

Interrupt, hardware

→ Hardware interrupt

Interrupt response time

The interrupt response time is the time from when an interrupt signal first occurs to calling the first instruction in the interrupt OB. The following general rule applies: Higher priority interrupts take precedence. This means that the interrupt response time is increased by the program processing time of the higher priority interrupt OBs and interrupt OBs with the same priority that have not yet been processed (queue).

I/O bus

This is part of the → backplane bus in the programmable controller, optimized for the rapid exchange of signals between the CPU(s) and the signal modules. User data (for example, digital input signals of a signal module) and system data (for example, default parameter data records of a signal module) are transferred via the I/O bus.

Isolated

With optically isolated input/output modules, the reference potentials of the control and load circuit are galvanically isolated (by an optocoupler, contact assembly or repeater, for example). Input/output circuits can be connected to common potential.

Keep last value (KLV)

The module retains the last value read out before STOP mode.

Load memory

The load memory is part of a programmable module (CPU, CP). It contains objects generated by the programming device (load objects). It is implemented either as a plug-in memory card or a permanently integrated memory. In the case of SIMATIC M7, the load memory can also be defined as a directory on the hard disk.

Local data

Local data are data assigned to a → code block that is declared in its → declaration section and its variable declaration. It includes (depending on the block): formal parameters, → static data, → temporary data.

Logic block

In the context of SIMATIC S7, a logic block is a block that contains part of the *STEP 7* user program. By contrast, a data block only contains data. There are the following logic blocks: organization blocks (OBs), function blocks (FBs), functions (FCs), system function block (SFBs), system functions (SFCs).

M7

Owing to its standardized AT computer architecture, automation computers M7-300 and M7-400 represent a freely programmable expansion of the SIMATIC automation platform. The hardware configuration is similar to that of a S7-300 or S7-400. The user programs for the SIMATIC M7 can also be programmed in a high-level language, such as C, or graphically.

Master

When they are in possession of access rights on the → bus, masters can send data to other nodes and request data from other nodes (= active node).

Measuring principle, instantaneous value encoding

A module with instantaneous value encoding is always used for very fast measuring operations or variables that change very rapidly. In this process, the module accesses the variable to be measured as fast as possible and delivers an instantaneous snapshot of the signal at a particular time. Due to this measuring procedure, the modules are more "sensitive" than modules with an integrating measuring procedure. Interference affecting the measured value can thus corrupt the result. You must ensure when using these modules that the measuring signal is clean by adhering strictly to the installation guidelines, for example.

Measuring principle, integrating

A module with an integrating measuring procedure is always used for non-time-critical measuring operations. The integration time is inversely proportional to the line frequency. You can set the latter in *STEP 7*. This then gives you the integration time. If the line frequency is 50 Hz, the integration time is 20 ms or an even multiple of that. Because the measured value is included up to exactly this time period, at least one or more whole periods of the line frequency, which may overlay the measuring signal, are also included. The average value of the error is therefore included as zero (positive part of the first half period = negative part of the second half period). Only the user signal is thus recorded.

Measuring range module

Measuring range modules are plugged into the analog input modules for adaptation to different measuring ranges.

Memory card

Pluggable load memory. Memory cards are credit-card size storage media for CPUs and CPs. They are implemented as → RAM or → FEPROMs.

Memory reset

In a memory reset, the following memories of the CPU are deleted: working memory, write/read area of the load memory, system memory.

In S7 and M7, the MPI parameters and diagnostic buffer are preserved.

In M7, the operating system is also rebooted when the memory of the M7 computer is reset by means of the mode selector.

Mode selector

Using the mode selector, the user can set the current operating mode of the CPU (RUN, RUN-P, STOP) or reset the memory of the CPU (MRES).

Module filtering mode

By operating mode we mean:

1. The selection of an operating mode of the CPU using the mode switch or the PG
2. The type of program execution in the CPU

MPI

The multipoint interface (MPI) is the programming device interface of the SIMATIC S7. It is used to access programmable modules (CPUs, CPs), text displays and operator panel from a central point. The nodes on the MPI can communicate with each other.

Multicomputing

Multicomputing operation is the synchronous operation of several (2 to 4) CPUs in an appropriate central rack of the S7-400.

Multiprocessor operation

During multiprocessor operation, several CPUs access one or more master interfaces for → PROFIBUS DP.

Non-isolated

In the case of non-isolated input/output modules, the reference potentials of the control and load circuit are electrically connected.

OB

→ Organization block

Organization block

Organization blocks (OBs) form the interface between the operating system of the CPU and the user program. The order in which the user program is processed is defined in the organization blocks.

Operating mode

The SIMATIC S7 programmable controllers have the following operating modes: STOP, → STARTUP, RUN and STOP.

Operating system

The operating system of the CPU organizes all functions and processes of the CPU that are not tied to a specific control task.

Parameters

1st tag of a → logic block
2nd tag for setting the characteristics of a module (one or more per module).
When delivered to the customer, each module has a practical basic setting for its parameters, which the user can modify in *STEP 7*.

PG

→ Programming device

PLC

→ Programmable controller

Point-to-point connection

Only two nodes are physically linked with one another in a point-to-point connection. This type of communication link is used if the use of a communication network is not recommended or when, for example, different types of partners, such as a PLC and a process computer, are to be connected.

Priority class

The operating system of an S7 CPU has a maximum of 28 priority classes (= program execution levels) – for cyclic program scanning or program scanning controlled by hardware interrupt, for example.

Each priority class is assigned → organization blocks in which the user can program a response. By default, the OBs have different priorities determining the order in which they are executed or interrupted in the event that they are activated simultaneously. The user can change the default priorities.

Process image

The signal states of the digital input and output modules are stored in the CPU in a process image.

A distinction is made between the process input image and the process output image. The process input image (PII) is read by the input modules before the operating system scans the user program. The process output image (PIQ) is transferred to the output modules at the end of program scanning.

Product status

Products having an identical order number are distinguished by their product status. The product status is incremented for upwards compatible extensions, modifications due to production reasons (use of new component parts and components) and troubleshooting.

PROFIBUS-DP

Digital, analog and intelligent I/O modules and a wide range of field devices complying with EN 50170, Part 3, such as drives or valve terminals, are moved by the automation system to the process on site, over a distance of up to 23 km. The modules and field devices are connected to the programmable controller by means of the PROFIBUS-DP fieldbus and addressed in the same way as central I/O.

Programmable controller

Programmable controllers (PLCs) are electronic controllers whose function is stored as a program on the control device. The design and wiring of the device do not therefore depend on the function of the controller.

The architecture of a programmable controller is similar to that of a computer; it consists of a → CPU (central processing unit) with memory, input/output modules and an internal bus system. The I/O and the programming language are designed to meet the requirements of open-loop control.

Programmable controller

A programmable controller → consists of a → central device, a CPU and diverse input/output modules.

Programming device

A programming device (PG) is an industry-standard, compact personal computer. A PG is completely equipped for programming SIMATIC programmable controllers.

Protection level

The SIMATIC S7 access protection concept prevents the central processing unit from being accessed by unauthorized persons. It has three protection levels:
Protection level 1: all program device functions allowed
Protection level 2: read-only program device functions allowed
Protection level 3: no program device functions allowed

RAM

A RAM (random access memory) is a semiconductor memory with random access.

RC element

Series connection of ohmic resistance and capacitor. When a load is disconnected, overvoltage occurs in circuits with inductive load. This can result in an arc and reduce the lifetime of the contacts. To suppress this arc, you can bridge the contact with an RC element.

Reboot

In the S7-400: When a CPU starts up, (for example, by switching the mode selector from STOP to RUN or by switching the power on), either OB 101 (restart) or OB 100 (reboot) is processed before cyclic program scanning (OB 1). In rebooting, the → process input image is read in and the *STEP 7* user program is processed, starting with the first instruction in OB1.
In the M7-400: At rebooting the process input image is read. User programs continue to be processed and notified about the STARTUP and RUN modes.

Reference ground

→ Ground

Reference channel error

Parameter in *STEP 7* for analog input modules. Using this parameter, you can enable the group error message of the reference junction when thermocouples are used. A reference channel error occurs when thermocouples are used and the following occurs:

- If an error occurs (for example, wire break) on a reference channel on which a thermal resistor (RTD) is connected to compensate for temperature drift (channel 0).
- If the → reference temperature is outside the permissible range of values. Each input channel that is assigned the “RTD on Channel 0” reference junction has a reference channel error in the situation described above. The measured temperature is no longer compensated.

Reference potential

Potential from which the voltages of the circuits involved are viewed and measured.

Reference temperature

Parameter in *STEP 7* for analog input modules. The reference temperature is the temperature at the reference junction (in 1/100 °C climatic temperature range) when thermocouples are used. The reference temperature makes it possible to measure the temperature correctly using thermocouples. The temperature at the reference junction must be known because a thermocouple always measures the difference in temperature between the measuring point and the reference junction.

Repeater

A device for the amplification of bus signals and connection of → bus segments over long distances.

Resolution

With analog modules, the number of bits which represent the digitized analog value in binary. The resolution depends on the module and with analog input modules on the → integration time. The precision of the resolution of a measured value increases with the length of the integration time. The resolution can be as many as 16 bits, including sign.

Response time

The response time is the time from an input signal being detected to the change to an output signal linked to it.

The actual response time is somewhere between a shortest and a longest response time. When configuring a system, you must always assume the longest response time.

Restart

When a CPU starts up (through the use of the mode selector, for example, or when the power is switched on), either OB 101 (restart), OB 100 (reboot: warm restart) or OB 102 (cold restart) is processed before cyclic program scanning (OB 1). It is essential for a restart that the CPU is up.

The following applies: All the data areas (timers, counters, memory markers, data blocks) and their contents are preserved. The → process input image is read, and processing of the *STEP 7* user program is continued from the point at which it was last terminated (STOP, power off).

Other types of startup are the → cold restart and reboot (→ warm restart).

Retentivity

Data areas in data blocks, and also timers, counters and memory markers are retentive when their contents are not lost upon a complete restart or POWER DOWN.

S7 basic communication

Communication functions integrated in the CPU of the SIMATIC S7/M7/C7 that can be called by the user. The call is executed in the user program by means of → system functions. The user data volume can be up to 76 bytes (small data volume). S7 basic communication is implemented via → MPI.

S7 communication

Communication functions integrated in the CPU of the SIMATIC S7/M7/C7 that can be called by the user. The call is executed in the user program by means of → system function blocks. The user data volume can be up to 64 Kbytes (large data volume). S7 communication offers a network-independent interface between devices of the type SIMATIC S7/M7/C7 and the programming device/PC.

Scan time

The scan time is the time required by the → CPU to scan the → user program once.

SDB

→ System data block

Segment

→ Bus segment

Sequence layer

Sequence layers form the interface in M7 between the operating system of the CPU and the user program. The order in which the blocks of the user program are processed is defined in the sequence layers.

SFB

→ System function block

SFC

→ System function

Short-circuit

Connection with negligibly low impedance between operationally opposed live conductors. The current is a multiple of the operating current; this can result in thermal overloading (rated short-time current) or mechanical overloading (rated peak withstand current) of the switchgear and system components.

Shunt resistor

Parallel or shunt resistor in electrical circuits.

Signal module

Signal modules (SM) form the interface between the process and the programmable controller. There are input modules, output modules, input/output modules (both digital and analog).

Slave

A slave can only exchange data with a → master when requested by it to do so.

Smoothing

Parameter in *STEP 7* for analog input modules. The measured values are smoothed by digital filtering. For specific modules it is possible to choose between no, low, medium and high smoothing. The higher the smoothing, the greater is the time constant of the digital filter.

Standard communication

Communication via standard and standardized protocols, such as PROFIBUS DP or PROFIBUS FMS.

STARTUP

The STARTUP mode is traversed during the transition from STOP mode to RUN mode.

STARTUP can be triggered by the → mode selector or following power-on or by means of an operator input on the programming device.

Rebooting and restarting are the two different types of startup. Depending on the position of the mode selector, either a reboot or restart is executed in the case of the S7-400. A reboot is executed in the case of the M7-300/400.

STEP 7

Parameter assignment and programming software for the parameterization and creation of user programs for SIMATIC S7 controllers.

Substitute value

Substitute values are values that can be output to the process when signal output modules have failed or be used in the user program instead of a process value when signal input modules have failed.

The substitute values can be assigned parameters by the user in *STEP 7* (old value retained, substitute value 0 or 1). They are values which the output(s) have to output in the event of a CPU STOP.

SYNC

Control command of the → master to the → slave: freeze the outputs at their current value.

System data block

SDBs (system data blocks) are data areas on the central processing unit which contain system settings and module parameters. The system data blocks are created and modified in *STEP 7*.

System diagnostics

System diagnostics is the detection, analysis and reporting of errors that occur within the programmable controller. Examples of such errors are: program errors or failures on modules. System errors can be indicated with LED displays or in *STEP 7*.

System function

A system function (SFC) is a function integrated in the operating system of the CPU that can be called in the *STEP 7* user program like a function (→ FC), as required.

System function block

A system function block (SFB) is a → function block integrated in the operating system of the CPU that can be called in the *STEP 7* user program like a function block (FB), as required. The associated instance data block is in working memory.

Temperature coefficient

Parameter in *STEP 7* for analog input modules when measuring temperatures with a resistance thermometer (RTD). The temperature coefficient you select depends on the resistance thermometer being used (to DIN standard).

Transmission rate

Rate of data transmission (bit/s)

Two-conductor/three-conductor/four-conductor connection

Method of connection to the module – for example, of resistance thermometers/resistors to the front connector of the analog input module or of loads at the voltage output of an analog output module.

Two-wire transmitter/four-wire transmitter

Kind of transmitter (two-wire transmitter: supply (via terminals of the analog input module; four-wire transmitter: supply via separate terminals of the transmitter)

Ungrounded

Without galvanic connection to ground

User program

The user program contains all the statements, → declarations and data for signal processing required to control a system or process. It is assigned to a programmable module (CPU, FM, for example) and can be structured in smaller units (blocks).

Varistor

Voltage-dependent resistor

Warm restart

This is a reboot after a power failure using a set of dynamic data programmed by the user and a user program section defined in the system.

A warm restart is indicated by setting a status bit or by some other appropriate means that can be read by the user program and indicate that the standstill of the programmable controller, brought about by a power failure, has been detected in RUN mode.

Wire break

Parameter in *STEP 7*. A wire break test is used for monitoring the connection from the input to the encoder and from the output to the actuator. With wire break, the module detects a flow of current at the appropriately parameterized input/output.

Working memory

The working memory is a → random access memory in the → CPU which the processor accesses during program execution of the user program.

Index

A

- Accessories, C-1
- Accessories, M7-400, memory card, 11-8
- Actuator connection, to analog output module, 5-59
- Actuators, connecting, 13-42
- ADC-DAC error, analog input module, 5-66
- Address, Glossary-1
- Address area, setting, 7-9
- Address assignment, M7-400, CPUs, 11-40
- Aggregate current, Glossary-1
- Ambient conditions, 1-14, 7-2
 - climatic, 1-15
 - mechanical, 1-14
- Analog functions, STEP 7 blocks, 5-1
- Analog input module
 - ADC-DAC error, 5-66
 - channel error, 5-65
 - channel information available, 5-65
 - configuring error, 5-66
 - connecting resistance thermometers, 5-50
 - connecting resistors, 5-50
 - connecting sensor, 5-43
 - connecting thermocouple, 5-53
 - diagnostic data, B-14
 - diagnostic interrupt, 5-40
 - diagnostic message in measured value, 5-63
 - diagnostics, 5-40
 - EPROM error, 5-66
 - external malfunction, 5-65
 - ground short circuit, 5-66
 - hardware interrupt lost, 5-66
 - incorrect parameters, 5-65
 - interference frequency suppression, 5-41
 - internal malfunction, 5-65
 - isolated, 5-43
 - limit value, 5-40
 - measurement, 5-41
 - measuring range, 5-41
 - measuring range module incorrect/missing, 5-65
 - measuring type, 5-41
 - module malfunction, 5-65
 - no external auxiliary voltage, 5-65
 - no front connector, 5-65
 - non-isolated, 5-43
 - overflow, 5-66
 - parameter assignment error, 5-66
 - parameter assignment missing, 5-65
 - parameters, 5-40, A-10
 - potential difference, 5-43
 - RAM error, 5-66
 - reference channel error, 5-66
 - reference junction, 5-41
 - reference temperature, 5-41
 - run time calibration error, 5-66
 - SM 431; AI 16 x 13 Bit, 5-99
 - SM 431; AI 16 x 16 Bit, 5-107
 - SM 431; AI 8 x 13 Bit, 5-70
 - SM 431; AI 8 x 14 Bit, 5-77, 5-90
 - SM 431; AI 8 x 16 Bit, 5-130
 - SM 431; AI 8 x RTD x 16 Bit, 5-122
 - smoothing of analog input values, 5-36, 5-41
 - STOP operating mode, 5-65
 - structure of data record 1, A-11
 - temperature coefficient, 5-41
 - temperature unit, 5-41
 - underflow, 5-66
 - wire break, 5-66
 - wire break check, 5-40
- Analog input modules
 - causes of errors and remedies, 5-65
 - diagnostic messages, 5-64
- Analog module
 - assigning parameters, 5-39
 - behavior, 5-31
 - determination of measuring error/output error, 5-34
 - diagnostics, 5-63
 - EXTF LED, 5-63
 - interrupts, 5-67
 - INTF LED, 5-63
 - load voltage failure, 5-32
 - sequence of steps for commissioning, 5-6

- Analog output channel
 - conversion time, 5-37
 - response time, 5-38
 - Analog output module
 - connecting loads and actuators, 5-59
 - connecting loads to current output, 5-62
 - connecting loads to voltage output, 5-60
 - isolated, 5-59
 - output, 5-42
 - output range, 5-42
 - output type, 5-42
 - parameters, 5-42
 - response time, 5-38
 - settling time, 5-38
 - SM 432; AO 8 x 13 Bit, 5-141
 - Analog value
 - conversion, 5-7
 - sign, 5-7
 - Analog value representation, 5-7
 - binary representation of input ranges, 5-10
 - binary representation of output ranges, 5-23
 - for current measuring ranges, 5-13–5-16
 - for current output ranges, 5-27–5-30
 - for resistance thermometers, 5-15, 5-16, 5-17
 - for resistance-type sensors, 5-14
 - for thermocouple, 5-18, 5-19, 5-20, 5-21, 5-22
 - for voltage measurement ranges, 5-12
 - for voltage measuring ranges, 5-11–5-13
 - for voltage output ranges, 5-26–5-29
 - Analog-digital conversion, 13-44
 - Analog-to-digital conversion, 5-35
 - Approvals, 1-2
 - Area of application, 7-2
 - ATM 478, 12-15
 - dimensions of the AT module, 12-21
 - pin assignment of the AT module, 12-16
 - power consumptions, calculation, 12-19
 - technical specifications, 12-19
 - Auxiliary voltage missing
 - analog input module, 5-65
 - digital module, 4-11
- B**
- Backplane bus, Glossary-1
 - Backup battery, Glossary-1
 - shipping and storage conditions, 1-12
 - technical specifications, 3-6
 - Backup time, 3-7
 - calculating, 3-7
 - Backup voltage, external, Glossary-1
 - Basic error limit, 5-33
 - Basic execution time
 - analog input channels, 5-36
 - analog output channels, 5-38
 - Battery. *Siehe* backup battery
 - BIOS setup, M7-400, 11-16
 - exiting, 11-24
 - key control, 11-20
 - opening, 11-23
 - setup fields, 11-20
 - setup page "Boot Options", 11-36
 - setup page "Date/Time", 11-32
 - setup page "Floppy/Card", 11-35
 - setup page "Hard Disk", 11-33
 - setup page "IF modules", 11-25
 - setup page "Security", 11-30
 - setup page "System", 11-38
 - setup page "Timeout Function", 11-29
 - setup page "User Help", 11-24
 - BIOS, M7-400
 - hot keys, 11-19
 - power up, 11-17
 - warm restart, 11-18
 - Bus, Glossary-1
 - Bus connector, 11-15
 - Bus segment, Glossary-2
 - Bytes 0 and 1, of diagnostic data, B-3
- C**
- Cable length, 7-3
 - selecting, 7-7
 - Cable length selector switch, 7-5
 - Cables, for analog signals, 5-43, 5-59
 - Causes of errors and remedies
 - analog input module, 5-65
 - digital module, 4-11
 - CE mark, 1-2
 - Central controller, Glossary-2
 - Channel error
 - analog input module, 5-65
 - digital module, 4-11
 - Channel information available
 - analog input module, 5-65
 - digital module, 4-11
 - Cold restart, Glossary-2
 - Commissioning analog modules, sequence of steps, 5-6
 - Commissioning digital modules, sequence of steps, 4-5
 - Common mode voltage, Glossary-2

Communication bus, 2-5
 Communication load, Glossary-2
 Communication processor, Glossary-2
 Comparison point, 5-57, Glossary-3
 Compensating box, 5-55, Glossary-3
 connecting, 5-56
 Compensation
 external, 5-55
 internal, 5-55, 5-56
 Config. index, M7-400, 11-27
 Configure, Glossary-3
 Configuring error, analog input module, 5-66
 Connecting cable, 6-5
 plugging in, 7-7
 preparing, 7-6
 Connecting cable 721, 7-11
 Connection
 distributed, 7-2
 loads/actuators, 13-42
 rules, 6-4
 Conversion time
 analog input channel, 13-44
 analog input channels, 5-35
 analog output channel, 5-37, 13-45
 Converting, analog values, 5-7
 CP, Glossary-2
 CPU, Glossary-3
 CPU 488-4, M7-400
 performance features, 11-2
 technical specifications, 11-3
 CPU 488-5, M7-400
 performance features, 11-2
 technical specifications, 11-3
 CPUs, M7-400, 11-1
 expansion socket, 11-14
 function elements, 11-4
 main memory and interrupt assignment,
 11-40
 memory card, 11-8
 mode selector switch, 11-9
 multipoint interface (MPI), 11-15
 performance features, 11-2
 status and fault LEDs, 11-6
 submodule receptacles for interface
 submodules, 11-11
 suitable submodules, 11-13
 technical specifications, 11-3
 CSA, 1-4
 Current sensors, connecting, 5-47
 Cycle time, analog input module, 13-44

D

Data
 static, Glossary-3
 temporary, Glossary-3
 Data block, Glossary-3
 Data record, for diagnostic data, B-2
 Data record 1
 analog input module configuration, A-11
 digital output module configuration, A-8
 structure for digital input module, A-4
 Data records, for parameters, A-2
 Date, M7-400, 11-32
 Declaration, Glossary-4
 Default setting, Glossary-4
 Degree of protection, 1-18
 IP 20, 1-18
 Delay time, M7-400, 11-29
 Destination CPU for interrupt, Glossary-4
 digital output module, 4-8
 Device security, M7-400, 11-30
 Diagnostic buffer, Glossary-4
 Diagnostic data, Glossary-4
 bytes 0 and 1, B-3
 data record, B-2
 of the analog input modules, B-14
 of the digital input modules, B-4
 of the digital output modules, B-8
 of the SM 421; DI 16 x 24 VDC, B-4
 of the SM 421; DI 16 x 24/60 VUC, B-6
 of the SM 422; DO 16 x 20-120 VAC/2 A,
 B-12
 of the SM 422; DO 16 x 20-125 VDC/1.5 A,
 B-8
 of the SM 422; DO 32 x 24 VDC/0.5 A, B-10
 of the SM 431; AI 16 x 16 Bit, B-14
 of the SM 431; AI 8 x 16 Bit, B-18
 of the SM 431; AI 8 x RTD x 16 Bit, B-16
 Diagnostic interrupt enable
 digital input module, 4-7
 digital output module, 4-8
 Diagnostic interrupt
 IF 971-AIO, 13-53
 of analog modules, 5-67
 of digital modules, 4-13
 Diagnostic messages, 4-9, 5-63
 of analog input modules, 5-64
 of the digital modules, 4-10
 reading out, 4-9, 5-63

Diagnostics

- analog input module, 5-40
- digital input module, 4-7
- digital output module, 4-8
- of analog modules, 5-63
- of digital modules, 4-9
- system, Glossary-18

Diagnostics entry, 5-32

Digital input module

- diagnostic data, B-4
- diagnostic interrupt enable, 4-7
- diagnostics, 4-7
- hardware interrupt enable, 4-7
- input delay, 4-7
- keep last value, 4-7
- no load voltage L+, 4-7
- parameters, 4-7
- sensor supply missing, 4-7
- SM 421; DI 16 x 120 VAC, 4-41
- SM 421; DI 16 x 120/230 VUC, 4-50, 4-53
- SM 421; DI 16 x 24 VDC, 4-23, 4-32
- SM 421; DI 16 x 24/60 VUC, 4-44
- SM 421; DI 32 x 120 VUC, 4-56
- SM 421; DI 32 x 24 VDC, 4-17, 4-20
- structure of data record 1, A-4
- substitute "1", 4-7
- substitute a value, 4-7
- wire break check, 4-7

Digital input modules, parameters, A-4

Digital module

- assigning parameters, 4-6
- causes of errors and remedies, 4-11
- channel error, 4-11
- channel information available, 4-11
- diagnostic messages, 4-10
- diagnostics, 4-9
- EPROM error, 4-11
- external malfunction, 4-11
- EXTF LED, 4-9
- fuse blown, 4-12
- hardware interrupt, 4-14
- hardware interrupt lost, 4-11, 4-14
- internal malfunction, 4-11
- internal voltage failure, 4-11
- interrupt-triggering channels, 4-14
- interrupts, 4-13
- INTF LED, 4-9
- M short circuit, 4-11
- module malfunction, 4-11
- no auxiliary voltage, 4-11
- no front connector, 4-11
- no load voltage L+, 4-12
- no sensor supply, 4-12
- parameter assignment error, 4-11
- parameter assignment missing, 4-11
- sequence of steps for commissioning, 4-5
- short circuit to L+, 4-11
- STOP mode, 4-11
- wire break, 4-12
- wrong parameters, 4-11

- Digital output module
 - destination CPU for Interrupt, 4-8
 - diagnostic data, B-8
 - diagnostic interrupt enable, 4-8
 - diagnostics, 4-8
 - fuse blown, 4-8
 - keep last value, 4-8
 - no load voltage L+, 4-8
 - parameters, 4-8, A-7
 - short circuit to L+, 4-8
 - short circuit to M, 4-8
 - SM 422; DO 16 x 120/230 VAC/2 A, 4-83
 - SM 422; DO 16 x 20–120 VAC/2 A, 4-87
 - SM 422; DO 16 x 20–125 VDC/1.5 A, 4-65
 - SM 422; DO 16 x 24 VDC/2 A, 4-59, 4-62
 - SM 422; DO 16 x 30/230 VUC/Rel.5 A, 4-91
 - SM 422; DO 32 x 24 VDC/0.5 A, 4-70, 4-73
 - SM 422; DO 8 x 120/230 VAC/5 A, 4-79
 - structure of data record 1, A-8
 - substitute "1", 4-8
 - substitute a value, 4-8
 - wire break check, 4-8
 - Direct access, Glossary-4
 - Direct communication, Glossary-5
 - DMA request, M7-400, 11-27
 - DP master, Glossary-5
 - DP slave, Glossary-5
 - Drive A, M7-400, 11-35
 - Drive B, M7-400, 11-35
- E**
- Edge, Glossary-5
 - EEPROM, Glossary-5
 - Einsatz der ET 200 / S7–300 in Zone 2, 1-19
 - Electromagnetic compatibility, 1-9
 - EMC directive, 1-2
 - EMV, 7-2
 - EPROM, Glossary-5
 - EPROM error
 - analog input module, 5-66
 - digital module, 4-11
 - Equipdistance, Glossary-5
 - Equipotential bonding, Glossary-6
 - Error, of an analog module, 5-34
- EXM 478, 12-6
 - addressing, 12-7
 - base addresses of the interface
 - submodules, 12-11
 - interrupt assignment, 12-13
 - numbering of the submodule receptacles, 12-8
 - signal switching, 12-13
 - technical specifications, 12-14
 - Expansion modules, M7-400, submodule
 - receptacles for interface submodules, 11-11
 - Expansion socket, M7-400, CPU, 11-14
 - Expansions
 - expansion socket, 12-2
 - maximum expansions, 12-3
 - overview, 12-2
 - permissible combinations, 12-5
 - External malfunction
 - analog input module, 5-65
 - digital module, 4-11
 - EXTF LED
 - analog module, 5-63
 - digital module, 4-9
- F**
- Fault LEDs, M7-400, CPUs, 11-6
 - FB, Glossary-7
 - FC, Glossary-7
 - FEPROM, Glossary-6
 - Fiber-optic cable, Glossary-6
 - FM, approval, 1-8
 - Force, Glossary-6
 - Four-conductor connection, 5-51, Glossary-19
 - Four-wire transducers, 13-37
 - connection, 13-40
 - Four-wire transmitter, Glossary-19
 - Four-wire transmitters, 5-49
 - FREEZE, Glossary-6
 - Front connector missing
 - analog input module, 5-65
 - digital module, 4-11
 - Function (FC), Glossary-7
 - Function block (FB), Glossary-7
 - Function elements, M7-400, CPUs, 11-4

Functional grounding, Glossary-7

Fuse blown, Glossary-7

digital module, 4-12

digital output module, 4-8

G

Global data, Glossary-7

Ground, Glossary-7

Ground short circuit, analog input module, 5-66

Grounded operation, RS 485 repeater, 10-4

Grounding

for the analog inputs, IF 961-AIO, 13-36

for the analog outputs, IF 961-AIO, 13-36

H

Hardware interrupt, Glossary-8

end of scan cycle, 5-69

of digital modules, 4-14

when limit exceeded, 5-68

Hardware interrupt enable, digital input

module, 4-7

Hardware interrupt lost

analog input module, 5-66

digital module, 4-11, 4-14

Hardware interrupt, IF 961-AIO, 13-53

Hot keys, M7-400, 11-19

I

I/O base, M7-400, 11-26

I/O bus, 2-5, Glossary-9

IEC 61131-2, 1-2

IF 961-AIO, 13-33

addressing, 13-46

analog input function, 13-48

analog output function, 13-47

analog value representation inputs, 13-51

analog value representation output, 13-52

characteristics, 13-33

circuit block diagram, 13-35

cyclic conversion of the ADC channels,

13-50

electrical installation, 13-46

individual start of an ADC channel, 13-49

interrupt, 13-53

measured value sensors, connecting, 13-37

measuring range selection, 13-33

output range selection, 13-33

pin assignments, 13-34

starting up, 13-46

submodule ID, 13-53

technical specifications, 13-54

terminal connection diagram, 13-34

unswitched channels, 13-37, 13-46

IF 961-CT1, 13-56

addressing, 13-59

characteristics, 13-56

technical specifications, 13-60

IF 961-DIO, 13-23

addressing, 13-26

acknowledgment register, 13-27

digital input function, 13-26

digital output function, 13-27

interrupt enable register, 13-28

interrupt register, 13-28

mode register, 13-30

selection register falling edge, 13-29

selection register rising edge, 13-29

characteristics, 13-23

pin assignments, 13-24

technical specifications, 13-31

IF 962-COM, 13-10

addressing, 13-12

AT-compatible, 13-12

M7-300/400-reserved, 13-13

characteristics, 13-10

interrupts, 13-15

pin assignments COM, 13-11

technical specifications, 13-15

- IF 962-LPT, 13-16
 - addressing, 13-18
 - AT-compatible, 13-18
 - M7-300/400 reserved, 13-19
 - characteristics, 13-16
 - interrupt request, 13-21
 - pin assignments, 13-17
 - technical specifications, 13-22
- IF 962-VGA, 13-5
 - addressing, 13-7
 - characteristics, 13-5
 - interrupts, 13-7
 - keyboard connection, 13-6
 - pin assignments VGA, 13-6
 - submodule ID, 13-7
 - technical specifications, 13-8
 - video operating modes, 13-9
- IF 964-DP, 13-61
 - additional information, 13-62
 - addressing, 13-64
 - addressing (intermediate) memory, 13-64
 - characteristics, 13-61
 - interrupts, 13-64
 - pin assignments, 13-63
 - technical specifications, 13-65
- IM 314, 7-2
- IM 467, 8-2
 - communication services, 8-3
 - configuration, 8-6
 - connection to PROFIBUS DP, 8-8
 - technical specifications, 8-12
- IM 467 FO, 8-2
 - communication services, 8-3
 - configuration, 8-6
 - connection to PROFIBUS DP, 8-8
 - fiber-optic cable, connecting, 8-10
 - technical specifications, 8-13
- Input characteristic curve to IEC 61131, for digital inputs, 4-15
- Input delay, Glossary-8
 - digital input module, 4-7
- Insertion rules, interface submodule, 13-4
- Insulation test, 1-18
- Integration time, Glossary-8
- Interface, selecting, 7-7
- Interface module
 - IM 460-1 and IM 461-1, 6-10
 - IM 460-3, 6-14
 - IM 460-3 and IM 461-3, 6-14
 - IM 460-4, 6-18
 - IM 460-4 and IM 461-4, 6-18
 - IM 461-3, 6-14
 - signal switching, 13-3
- Interface modules
 - IM 460-0, 6-7
 - IM 460-1, 6-10
 - IM 461-0, 6-7
 - IM 461-1, 6-10
 - IM 461-4, 6-18
- Interface selector switch, 7-5
- Interface submodules
 - addressing, 13-2
 - in the AT-compatible I/O address area, 12-7
 - in the M7-400-specific I/O address area, 12-7
 - base address, 12-10, 12-11
 - insertion rules, 13-4
 - interrupt assignment, 12-13, 13-3
 - numbering of the submodule receptacles, 12-8
 - shared interrupt, 13-3
 - signal switching, 12-13
 - submodule ID, 13-4
- Interference
 - pulse-shaped, 1-10
 - sinusoidal, 1-10
- Interference frequency suppression, Glossary-8
 - analog input module, 5-41
- Internal fault (INTF), 3-14
- Internal malfunction
 - analog input module, 5-65
 - digital module, 4-11
- Internal voltage failure, digital module, 4-11
- Interrupt, Glossary-8
- Interrupt assignment, M7-300, CPUs, 11-40
- Interrupt response time, Glossary-9
- Interrupt source, M7-400, 11-27

- Interrupt-triggering channels, of the digital module, 4-14
 - Interrupts
 - enabling, 4-13, 5-67
 - of analog modules, 5-67
 - of the digital modules, 4-13
 - INTF LED
 - analog module, 5-63
 - digital module, 4-9
 - IP 20, 1-18
 - Isolated, Glossary-9
 - Isolated measuring sensor, 5-44
 - Isolated measuring sensors, connecting, 5-44
- K**
- Keep last value
 - digital input module, 4-7
 - digital output module, 4-8
 - Key control, M7-400, 11-20
 - KLV, Glossary-9
- L**
- LBA mode, M7-400, 11-34
 - LEDs, 7-5
 - Limit value, analog input module, 5-40
 - Load connection, to analog output module, 5-59
 - Load connection to current output, on analog output module, 5-62
 - Load connection to voltage output, to analog output module, 5-60
 - Load memory, Glossary-9
 - Load voltage failure, of the analog module, 5-32
 - Load voltage L+ missing, digital module, 4-12
 - Loads, connecting, 13-42
 - Local data, Glossary-10
 - Logic block, Glossary-10
 - Low voltage directive, 1-3
- M**
- M short circuit, digital module, 4-11
 - M7, Glossary-10
 - M7-400
 - main memory assignment, 11-40
 - parameter assignment in user program, A-2
 - Main memory assignment, 11-40
 - Master, Glossary-10
 - Maximum expansion, 7-3
 - Measured value sensors
 - isolated, 13-38
 - non-isolated, 13-39
 - Measurement, analog input module, 5-41
 - Measuring method, analog input channels, 5-28
 - Measuring principle
 - instantaneous value encoding, Glossary-10
 - integrating, Glossary-10
 - Measuring range
 - analog input channels, 5-28
 - analog input module, 5-41
 - Measuring range module, 5-28
 - replugging, 5-29
 - Measuring range module incorrect/missing, analog input module, 5-65
 - Measuring sensor, isolated, 5-44
 - Measuring type, analog input module, 5-41
 - Memory assignment, M7-400, 11-40
 - Memory card, Glossary-11
 - Memory card, M7-400, CPUs, 11-8
 - Memory reset, Glossary-11
 - Memory submodules, M7-400, note on ordering, C-3
 - Mode selector, Glossary-11
 - Mode selector switch, M7-400, CPUs, 11-9
 - Module classes, ID, B-3
 - Module filtering mode, Glossary-11
 - Module malfunction
 - analog input module, 5-65
 - digital module, 4-11
 - Module overview, 5-3
 - digital modules, 4-3
 - Modules, shipping and storage conditions, 1-12
 - MPI, Glossary-11
 - MSM 478
 - characteristics, 12-22
 - parallel port (LPT), 12-23
 - technical specifications, 12-25
 - Multicomputing, Glossary-11
 - Multipoint interface MPI, M7-400, CPUs, 11-15
 - Multiprocessor operation, Glossary-11
- N**
- NAMUR recommendation, 3-3
 - No load voltage L+, digital output module, 4-8
 - Non-isolated, Glossary-12

Non-isolated sensors, 5-45
 connecting, 5-45

O

OB, Glossary-12
 OB 40, 4-14, 5-68
 start information, 5-68
 OB 82, 4-13, 5-67
 Operating conditions, 1-14
 Operating mode, Glossary-12
 of CPU, 5-31
 Operating system, Glossary-12
 Operational limit, 5-33
 Order number
 6ES7 401-2TA01-0AA0, 2-8
 6ES7 405-0DA00-0AA0, 3-30
 6ES7 405-0DA01-0AA0, 3-32
 6ES7 405-0KA00-0AA0, 3-34
 6ES7 405-0KA01-0AA0, 3-36
 6ES7 405-0KR00-0AA0, 3-36
 6ES7 405-0RA00-0AA0, 3-38
 6ES7 405-0RA01-0AA0, 3-40
 6ES7 407-0DA00-0AA0, 3-19
 6ES7 407-0DA01-0AA0, 3-21
 6ES7 407-0KA01-0AA0, 3-23
 6ES7 407-0KR00-0AA0, 3-23
 6ES7 407-0RA00-0AA0, 3-26
 6ES7 407-0RA01-0AA0, 3-28
 6ES7 421-1BL00-0AA0, 4-17
 6ES7 421-1BL01-0AA0, 4-20
 6ES7 421-1EL00-0AA0, 4-56
 6ES7 421-1FH00-0AA0, 4-50
 6ES7 421-1FH20-0AA0, 4-53
 6ES7 421-5EH00-0AA0, 4-41
 6ES7 421-7BH00-0AB0, 4-23, 4-32
 6ES7 421-7DH00-0AB0, 4-44
 6ES7 422-1BH10-0AA0, 4-59
 6ES7 422-1BH11-0AA0, 4-62
 6ES7 422-1BL00-0AA0, 4-70
 6ES7 422-1FF00-0AA0, 4-79
 6ES7 422-1FH00-0AA0, 4-83
 6ES7 422-1HH00-0AA0, 4-91
 6ES7 422-5EH00-0AB0, 4-87
 6ES7 422-5EH10-0AB0, 4-65
 6ES7 422-7BL00-0AB0, 4-73
 6ES7 431-0HH00-0AB0, 5-99
 6ES7 431-1KF00-0AB0, 5-70
 6ES7 431-1KF10-0AB0, 5-77
 6ES7 431-1KF20-0AB0, 5-90
 6ES7 431-7KF00-0AB0, 5-130
 6ES7 431-7KF10-0AB0, 5-122

6ES7 431-7QH00-0AB0, 5-107
 6ES7 432-1HF00-0AB0, 5-141
 6ES7 460-0AA00-0AB0, 6-7
 6ES7 460-0AA01-0AB0, 6-7
 6ES7 460-1BA00-0AB0, 6-10
 6ES7 460-1BA01-0AB0, 6-10
 6ES7 460-3AA00-0AB0, 6-14
 6ES7 460-3AA01-0AB0, 6-14
 6ES7 460-4AA01-0AB0, 6-18
 6ES7 461-0AA00-0AA0, 6-7
 6ES7 461-0AA01-0AA0, 6-7
 6ES7 461-1BA00-0AA0, 6-10
 6ES7 461-1BA01-0AA0, 6-10
 6ES7 461-3AA00-0AA0, 6-14
 6ES7 461-3AA01-0AA0, 6-14
 6ES7 461-4AA01-0AA0, 6-18
 6ES7 467-5FJ00-0AB0, 8-2
 6ES7 467-5GJ00-0AB0, 8-2
 6ES7 467-5GJ01-0AB0, 8-2
 6ES7 467-5GJ02-0AB0, 8-2
 6ES7 972-0AA01-0XA0, 10-2

Organization block (OB), Glossary-12
 Output, analog output module, 5-42
 Output analog values, STEP 7 blocks, 5-1
 Output range, analog output module, 5-42
 Output type, analog output module, 5-42
 Overflow, analog input module, 5-66

P

Parameter assignment
 for analog modules, 5-39
 for digital modules, 4-6
 in user program, A-2
 Parameter assignment error
 analog input module, 5-66
 digital module, 4-11
 Parameter assignment missing
 analog input module, 5-65
 digital module, 4-11
 Parameters, Glossary-12
 analog input module, 5-40, A-10
 analog output module, 5-42
 data records, A-2
 digital input module, 4-7
 digital input modules, A-4
 digital output module, 4-8, A-7
 dynamic, 4-6, 5-39
 modifying in user program, 4-6, 5-39
 static, 4-6, 5-39
 Parameters incorrect, analog input module,
 5-65

- PARM_MOD, SFC 57, A-2
 Password, M7-400, 11-31
 Performance features, M7-400, CPUs, 11-2
 Permissible potential differences, 7-3
 PG cable, 11-15, C-2
 Pin assignment, RS 485 repeater, 10-6
 PLC, Glossary-13
 Point-to-point connection, Glossary-12
 Potential difference, with analog input modules, 5-43
 Power supply module
 PS 405 10A, 3-34, 3-36
 PS 405 10A R, 3-36
 PS 405 20A, 3-38, 3-40
 PS 405 4A, 3-30, 3-32
 PS 407 10A, 3-23
 PS 407 10A R, 3-23
 PS 407 20A, 3-26, 3-28
 PS 407 4A, 3-19, 3-21
 Priority class, Glossary-13
 Process image, Glossary-13
 Product status, Glossary-13
 PROFIBUS DP, Glossary-13
 PROFIBUS DP master interface, 8-2
 Programmable controller, Glossary-13
 Programmable controller (PLC), Glossary-13
 Programming device (PG), Glossary-14
 Protection class, 1-18
 Protection level, Glossary-14
 Pulse edge, 4-7
 Pulse-shaped interference, 1-10
- Q**
- Quick memory test, 11-37
- R**
- Rack
 CR2, 2-7
 CR3, 2-8
 ER1, 2-9
 ER2, 2-9
 UR1, 2-3, 2-5
 UR2, 2-3, 2-5
 Radio interference, emission of, 1-11
 RAM, Glossary-14
 RAM error, analog input module, 5-66
 RC element, Glossary-14
 Read analog values, STEP 7 blocks, 5-1
 Read only, M7-400, 11-30
 Reboot, Glossary-14
 Redundant operation, 3-4
 Redundant power supply modules, 3-4
 Reference channel error, Glossary-15
 analog input module, 5-66
 Reference junction, analog input module, 5-41
 Reference junction temperature with
 thermocouples, compensating, 5-54
 Reference potential, Glossary-15
 Reference temperature, Glossary-15
 analog input module, 5-41
 Repeater, Glossary-15
 Siehe auch RS 485 repeater
 Resistance thermometer, connections, 13-41
 Resistance thermometer connection, to analog
 input module, 5-50
 Resistor connection, to analog input module,
 5-50
 Resolution, 5-7, Glossary-15
 Response time, 5-38, Glossary-15
 analog output, 13-45
 Restart, Glossary-16
 Retentivity, Glossary-16
 RS 485 repeater, 10-1
 appearance, 10-3
 application, 10-2
 definition, 10-2
 grounded, 10-4
 grounded operation, 10-4
 rules, 10-2
 ungrounded, 10-4
 ungrounded operation, 10-4
 Run time calibration error, analog input
 module, 5-66
- S**
- S5 modules, configuring, 7-10
 S7 basic communication, Glossary-16
 S7 communication, Glossary-16
 Scan time, Glossary-16
 analog input channels, 5-35
 analog output channels, 5-37
 SDB, Glossary-18
 Secondary cache size, M7-400, 11-38
 Select boot sequence, M7-400, 11-36
 Select submodule, M7-400, 11-26
 Sensor connection, to analog input module,
 5-43

- Sensor supply missing
 - digital input module, 4-7
 - digital module, 4-12
- Sensors, non-isolated, 5-45
- Sequence layer, Glossary-17
- Settling time, 5-38
 - analog output, 13-45
- Setup fields, M7-400, 11-20
- Setup page, M7-400
 - "Boot Options", 11-36
 - "Date/Time", 11-32
 - "Floppy/Card", 11-35
 - "Hard Disk", 11-33
 - "IF modules", 11-25
 - "Security", 11-30
 - "System", 11-38
 - "Timeout Function", 11-29
 - User Help, 11-24
- SFB, Glossary-19
- SFC, Glossary-17, Glossary-18
- SFC 51, 4-13, 5-67
- SFC 55 WR_PARM, A-2
- SFC 56 WR_DPARM, A-2
- SFC 57 PARM_MOD, A-2
- SFC 59, 4-13, 5-67
- Shared destination, M7-400, 11-27
- Short circuit to L+
 - digital module, 4-11
 - digital output module, 4-8
- Short circuit to M, digital output module, 4-8
- Short-circuit, Glossary-17
- Shunt resistor, Glossary-17
- SIG destination, M7-400, 11-28
- SIG source, M7-400, 11-28
- Sign, analog value, 5-7
- Signal module, Glossary-17
- Sinusoidal interference, 1-10
- Slave, Glossary-17
- SM 421; DI 16 x 24 VDC, diagnostic data, B-4
- SM 421; DI 16 x 24/60 VUC, diagnostic data, B-6
- SM 422; DO 16 x 20-120 VAC/2 A, diagnostic data, B-12
- SM 422; DO 16 x 20-125 VDC/1.5 A, diagnostic data, B-8
- SM 422; DO 32 x 24 VDC/0.5 A, diagnostic data, B-10
- SM 431; AI 16 x 16 Bit, diagnostic data, B-14
- SM 431; AI 8 x 16 Bit, diagnostic data, B-18
- SM 431; AI 8 x RTD x 16 Bit, diagnostic data, B-16
- Smoothing, Glossary-17
- Smoothing of analog input values, 5-36
 - analog input module, 5-41
- Spare parts, C-1
- Standard communication, Glossary-17
- Standards, 1-2
- Startup, Glossary-18
- Status LEDs, M7-400, CPUs, 11-6
- STEP 7, Glossary-18
- STEP 7 blocks, for analog functions, 5-1
- STOP mode, digital module, 4-11
- STOP operating mode, analog input module, 5-65
- Submodule IDs, interface submodule, 13-4
- Submodule receptacles for interface submodules, M7-400
 - CPUs, 11-11
 - expansion modules, 11-11
- Substitute "1"
 - digital input module, 4-7
 - digital output module, 4-8
- Substitute a value
 - digital input module, 4-7
 - digital output module, 4-8
- Substitute value, Glossary-18
- Suitable submodules, M7-400, CPUs, 11-13
- SYNC, Glossary-18
- System cache, M7-400, 11-38
- System data block (SDB), Glossary-18
- System diagnostics, Glossary-18
- System function (SFC), Glossary-18
- System function block (SFB), Glossary-19
- System perturbation, 1-11
- System ROM, 11-39
- System ROM, M7-400, 11-39

T

Technical specifications

- IF 961-AIO, 13-54
- IF 961-DIO, 13-31
- IF 962-COM, 13-15
- IF 962-LPT, 13-22
- IF 962-VGA, 13-8
- IF 964-DP, 13-65
- IM 460-0 and 461-0, 6-9
- IM 460-1 and 461-1, 6-13
- IM 460-3 and 461-3, 6-17
- IM 460-4 and 461-4, 6-21
- PS 405 10 A, 3-35
- PS 405 10A, 3-37
- PS 405 10A R, 3-37
- PS 405 20 A, 3-39, 3-41
- PS 405 4 A, 3-31, 3-33
- PS 407 10A, 3-25
- PS 407 10A R, 3-25
- PS 407 20 A, 3-27, 3-29
- PS 407 4 A, 3-22
- PS 407 4A, 3-20
- RS 485 repeater, 10-6
- Technical specifications, M7-400, CPUs, 11-3
- Temperature coefficient, Glossary-19
 - analog input module, 5-41
- Temperature unit, analog input module, 5-41
- Terminating connector, 7-3, 7-13
- Test voltages, 1-18
- Thermo emf, 5-53
- Thermocouple
 - design, 5-53
 - principle of operation, 5-53
- Thermocouple connection, to analog input module, 5-53
- Three-conductor connection, 5-52, Glossary-19
- Time, M7-400, 11-32
- Timeout mode, M7-400, 11-29
- Transducer
 - four-wire, 13-37
 - two-wire, 13-37

- Transmission rate, Glossary-19
- Two-conductor connection, 5-52, Glossary-19
- Two-wire transducers, 13-37
 - connection, 13-40
- Two-wire transmitter, Glossary-19
- Two-wire transmitters, 5-48
- Type configured, M7-400, 11-26

U

- UL, 1-4
- Underflow, analog input module, 5-66
- Ungrounded operation, RS 485 repeater, 10-4
- User program, Glossary-19
 - parameter assignment in, A-2

V

- Value, M7-400, 11-28
- Varistor, Glossary-19
- Vibrations, 1-15
- Video ROM, 11-39
- Voltage sensors, 13-37
 - connecting, 5-46
 - connection, 13-39

W

- Warm restart, Glossary-20
- Warm restart, M7-400, 11-18
- Wire break, Glossary-20
 - analog input module, 5-66
 - digital module, 4-12
- Wire break check
 - digital input module, 4-7
 - digital output module, 4-8
- Working memory, Glossary-20
- WR_DPARM, SFC 56, A-2
- WR_PARM, SFC 55, A-2
- Wrong parameters, digital module, 4-11