

Rexroth ServoDyn D Connectivity Manual Stand Alone Version

1070066036
Edition 03

Mounting guidelines

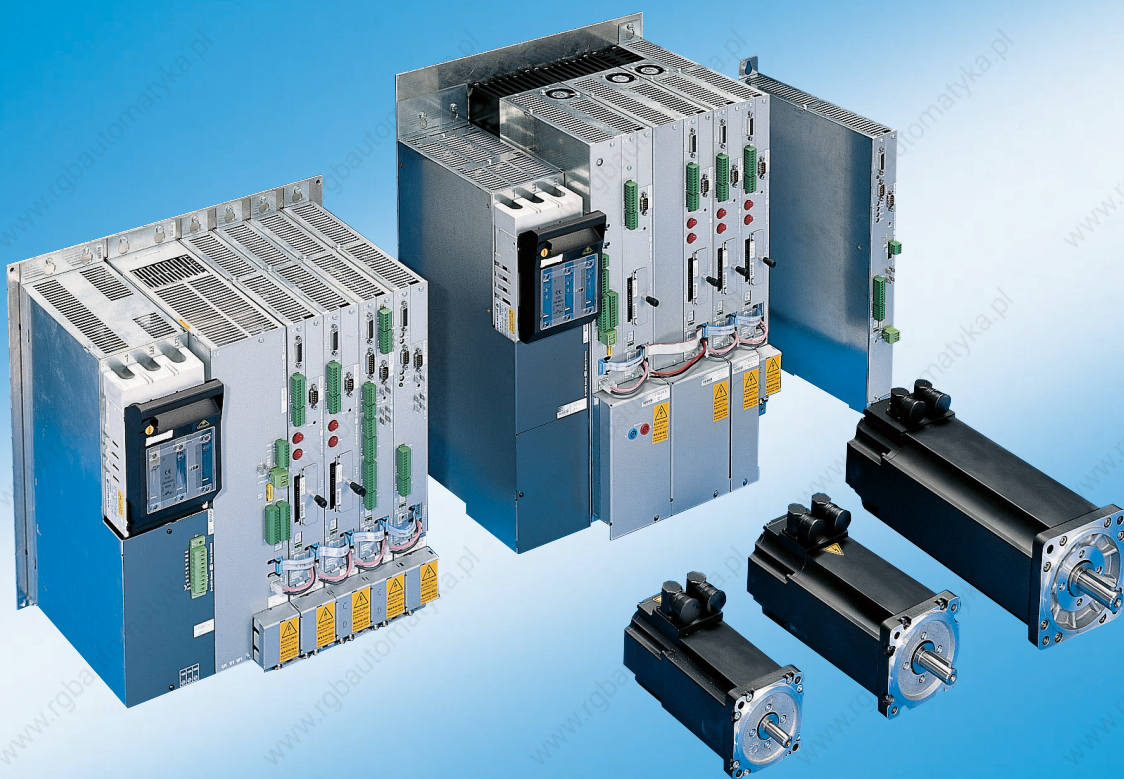

Title Rexroth ServoDyn D
Connectivity Manual
Stand alone version

Type of Documentation Mounting guidelines

Document Typecode DOK-SERV*D-STAND*ALONE-MA03-EN-P

Purpose of Documentation The present manual provides information on the installation of the ServoDyn D stand-alone inverters.

Record of Revisions

Description	Release Date	Notes
DOK-SERV*D-STAND*ALONE-MA03-EN-P	11.2004	

Copyright © Bosch Rexroth AG, 1998 – 2004

Copying this document, giving it to others and the use or communication of the contents thereof without express authority, are forbidden. Offenders are liable for the payment of damages. All rights are reserved in the event of the grant of a patent or the registration of a utility model or design (DIN 34-1).

Validity The data specified above only serve to describe the product. No statements concerning a certain condition or suitability for a certain application can be derived from our information. The given information does not release the user from the obligation of own judgement and verification. It must be remembered that our products are subject to a natural process of wear and aging.

Published by Bosch Rexroth AG
Postfach 11 62
D-64701 Erbach
Berliner Straße 25
D-64711 Erbach
Tel.: +49 (0) 60 62/78-0
Fax: +49 (0) 60 62/78-4 28
Abt.: BRC/ESM11 (WE)

Contents

Contents

	Page
1	Safety instructions 1–1
1.1	Intended use 1–1
1.2	Qualified personnel 1–2
1.3	Safety markings on products 1–3
1.4	Safety instructions in this manual 1–4
1.5	Safety instructions concerning the described product 1–5
1.6	Documentation, software release and trademarks 1–7
2	Switch cabinet structure 2–1
2.1	Drive components 2–1
2.2	Installation compartment 2–2
2.3	Layout of the drive components 2–3
2.3.1	Installation in compliance with UL/CSA 2–5
3	Installation 3–1
3.1	Layout and mounting position 3–1
3.2	Protective earth connection between the modules 3–2
3.3	Connection cables 3–2
4	Connection overview 4–1
4.1	NV and DS..K with analog interface 4–1
4.2	NV and DS..K with Motion Control 4–2
4.3	NV and DS..8001 frequency inverter with analog interface 4–3
4.4	NV and DS..K with SERCOS interface 4–4
4.5	NV and DS..K with CAN bus 4–5
4.6	NV and DS..K with PROFIBUS-DP 4–6
5	Power connection 5–1
5.1	Earthing 5–1
5.2	Electromagnetic compatibility (EMC) 5–3
5.3	Earth-leakage circuit-breaker 5–4
5.4	Mains supply 5–5
5.4.1	Connection via NV line wiring module 5–8
5.5	24 V supply 5–10
5.6	DC link connection 5–11
5.7	Motor connection 5–12
5.7.1	SF, SR servo motors power and brake connection 5–13
5.7.2	DU asynchronous motor power connection 5–20

Contents

6	Connections on supply module	6-1
6.1	Overview of DS..K xxx2 (in set-up mode)	6-1
6.2	Overview of DS..K xxx1	6-2
6.3	Terminal strips	6-3
6.4	Start logically linked to EMERGENCY-STOP switchgear .	6-6
7	DS control connections	7-1
7.1	Connection of analog interface or positioning function (MC)	7-1
7.1.1	Inputs	7-2
7.1.2	Outputs	7-6
7.2	Connection with SERCOS interface	7-7
7.3	Connection with CAN bus	7-10
7.4	Connection with PROFIBUS-DP	7-16
7.5	Connections on the DS..8001 frequency inverter	7-20
7.6	Standard connection of X34 (analog interface, SERCOS interface, CAN bus, PROFIBUS-DP)	7-28
7.7	RS 232 for commissioning and service system connection (DSS-D)	7-32
7.7.1	Motor encoder (X05)	7-33
7.8	Encoder switch / encoder simulation (X81)	7-37
7.9	Direct measuring system connection (X55)	7-39
7.10	High-speed analog outputs OM 04	7-48
8	Application instructions	8-1
8.1	Drive with SERCOS interface	8-1
8.1.1	Cycle power to the drive	8-1
8.1.2	EMERGENCY-STOP	8-4
8.2	Drive with analog interface, MC, CAN bus, PROFIBUS-DP	8-6
8.3	Transmission of the absolute encoder position with X81 .	8-7
8.4	Drives with positioning function	8-10
8.4.1	Jogging mode	8-10
8.4.2	Referencing	8-11
8.4.3	Automatic mode	8-12
9	Personality module	9-1
10	Dimensioned drawings	10-1
10.1	Dimensioned drawing, line wiring module NV with stand-alone inverters DS..K	10-1
10.2	Dimensioned drawing, plug braking modules	10-2
11	Part numbers	11-1
11.1	Accessories	11-1
11.2	Options	11-2
11.3	Spare fuses	11-2
A	Appendix	A-1
A.1	Index	A-1

Safety instructions

1 Safety instructions

Please read this manual before commissioning the ServoDyn D inverters. Store this manual in a place to which all users have access at any time.

1.1 Intended use

This manual contains information required for the intended use of this product.

The drive inverters described

- have been developed, manufactured, tested and documented in compliance with the safety standards. These products pose no danger to persons or property if they are used in accordance with the handling stipulations and safety notes prescribed for their configuration, mounting, and proper operation.
- comply with the requirements of
 - the EMC Directives (89/336/EEC, 93/68/EEC and 93/44/EEC)
 - the EMC product standard EN 61800-3 + A11
 - the Low-Voltage Directive (73/23/EEC)
 - the harmonized standards EN 50178 (VDE 0160) and EN 60146-1-1 (VDE 0558-11)
- are designed for operation in industrial environments, i.e.
 - no direct connection to public low-voltage power supply,
 - connection to the medium- or high-voltage system via a transformer.

In residential environments, in trade and commerce as well as small enterprises class A equipment may only be used if the following warning is attached:

 **This is a Class A device. In a residential area, this device may cause radio interference. In such case, the user may be required to introduce suitable countermeasures, and to bear the cost of the same.**

Before putting the drive inverters into operation, ensure that the machine which the inverters are to be installed in meets the stipulations of the machinery directive (98/37/EEC, 98/79/EEC) and the EMC directive (89/336/EEC).

The faultless, safe functioning of the product requires proper transport, storage, erection and installation as well as careful operation.

Safety instructions

1.2 Qualified personnel

The requirements as to qualified personnel depend on the qualification profiles described by ZVEI (central association of the electrical industry) and VDMA (association of German machine and plant builders) in:

Weiterbildung in der Automatisierungstechnik
edited by: ZVEI and VDMA
MaschinenbauVerlag
Postfach 71 08 64
D-60498 Frankfurt.

The present manual is designed for **drive technicians**.

Programming, start and operation as well as the modification of program parameters is reserved to properly trained personnel! This personnel must be able to judge potential hazards arising from programming, program changes and in general from the mechanical, electrical, or electronic equipment.

Interventions in the hardware and software of our products, unless described otherwise in this manual, are reserved to our specialized personnel.

Tampering with the hardware or software, ignoring warning signs attached to the components, or non-compliance with the warning notes given in this manual may result in serious bodily injury or material damage.

Only electrotechnicians as recognized under IEC 826-09-01 (modified) who are familiar with the contents of this manual may install and service the products described.

Such personnel are

- those who, being well trained and experienced in their field and familiar with the relevant norms, are able to analyze the jobs being carried out and recognize any hazards which may have arisen.
- those who have acquired the same amount of expert knowledge through years of experience that would normally be acquired through formal technical training.

With regard to the foregoing, please note our comprehensive range of training courses. Please visit our website at <http://www.boschrexroth.com> for the latest information concerning training courses, teaching and training systems. Personal information is available from our Didactic Center Erbach,
Telephone: (+49) (0) 60 62 78-600.

Safety instructions

1.3 Safety markings on products

Warning of dangerous electrical voltage!



Electrostatically sensitive components!



Warning of hazardous light emissions
(optical fibre cable emitters)!



Lug for connecting PE conductor only!



Connection of shield conductor only

Safety instructions

1.4 Safety instructions in this manual



DANGEROUS ELECTRICAL VOLTAGE

This symbol is used to warn of a **dangerous electrical voltage**. The failure to observe the instructions in this manual in whole or in part may result in **personal injury**.



DANGER

This symbol is used wherever insufficient or lacking compliance with instructions may result in **personal injury**.



CAUTION

This symbol is used wherever insufficient or lacking compliance with instructions may result in **damage to equipment or data files**.

☞ This symbol is used to draw the user's attention to special circumstances.

★ This symbol is used if user activities are required.

Safety instructions

1.5 Safety instructions concerning the described product**DANGER**

Danger of life through inadequate EMERGENCY-STOP devices! EMERGENCY-STOP devices must be active and within reach in all system modes. Releasing an EMERGENCY-STOP device must not result in an uncontrolled restart of the system! First check the EMERGENCY-STOP circuit, then switch the system on!

**DANGER**

**Danger for persons and equipment!
Test every new program before starting up a system!**

**DANGER**

**Retrofits or modifications may adversely affect the safety of the products described!
The consequences may include severe injury, damage to equipment, or environmental hazards. Possible retrofits or modifications to the system using third-party equipment therefore have to be approved by Rexroth.**

**DANGER**

**Health hazards through destroyed electrical components!
Do not destroy any built-in components. Dispose of destroyed components in a proper manner.**

**DANGER**

Do not look directly into the LEDs in the optical fiber connection. Due to their high output, this may result in eye injuries. When the inverter is switched on, do not look into the LED or the open end of a short connected lead.

**DANGER**

Please note your local, system-specific regulations and requirements as well as the proper use of tools, hoisting and transport equipment as well as the applicable standards, regulations, and accident prevention regulations.

Safety instructions



DANGEROUS ELECTRICAL VOLTAGE

Unless described otherwise, maintenance works must be performed on inactive systems! The system must be protected against unauthorized or accidental reclosing.

Measuring or test activities on the live system are reserved to qualified electrical personnel!



DANGEROUS ELECTRICAL VOLTAGE

Lethal voltages of up to 375 V DC against ground on all power connections and DC link connections!

The drives must not be switched on unless all covers have been fitted! When the drive has been disconnected from mains, wait for up to 5 minutes until the system is de-energized before removing any covers.

The drive must always be examined for safe isolation from supply!



CAUTION

Use only spare parts approved by Rexroth!



CAUTION

Danger to the module!

All ESD protection measures must be observed when using the module! Prevent electrostatic discharges!

The following protective measures must be observed for modules and components sensitive to electrostatic discharge (ESD)!

- Personnel responsible for storage, transport, and handling must have training in ESD protection.
- ESD-sensitive components must be stored and transported in the prescribed protective packaging.
- ESD-sensitive components may only be handled at special ESD-workplaces.
- Personnel, working surfaces, as well as all equipment and tools which may come into contact with ESD-sensitive components must have the same potential (e.g. by grounding).
- Wear an approved grounding bracelet. The grounding bracelet must be connected with the working surface through a cable with an integrated 1 MΩ resistor.
- ESD-sensitive components may by no means come into contact with chargeable objects, including most plastic materials.
- When ESD-sensitive components are installed in or removed from equipment, the equipment must be de-energized.

Safety instructions

1.6 Documentation, software release and trademarks

Documentation

The present manual provides information on the installation of the ServoDyn D stand-alone inverters.

Manuals	Part no.			
	German	English	French	Italian
Servo motors SF, SR	1070066 004	1070066 024	1070066 048	1070066 046
Asynchronous motors DU	1070066 007	1070066 027	–	–
ServoDyn D, Configuration - Manual for overview and rating	1070066 009	1070066 029	1070066 059	1070066 049
ServoDyn D, - Connectivity Manual - Stand alone version	1070066 016	1070066 036	1070066 066	1070066 056
ServoDyn D, - Parameter manual (without CANopen)	1070066 018	1070066 038	1070066 068	1070066 058
ServoDyn D, Servodyn-M - Parameter manual CANopen	1070066 094	1070066 095	–	–
ServoDyn D with SERCOS interface - Parameter and commissioning manual	1070066 011	1070066 031	–	1070066 051
ServoDyn D with analog interface - Commissioning manual	1070066 014	1070066 034	–	–
ServoDyn D with CANrho interface - Commissioning manual	1070066 017	1070066 037	–	–
ServoDyn D with motion control - Commissioning manual	1070066 015	1070066 035	–	–
ServoDyn D with PROFIBUS-DP - Commissioning manual	1070066 090	1070066 091	–	–
ServoDyn D Frequency inverters DM/DS..8001 (ASM) Parameter and commissioning manual	1070066 008	1070066 028	–	1070066 053
Diagnostics, maintenance	1070066 012	1070066 032	1070066 062	1070066 052
RSU, Redundant safety monitoring	1070066 006	1070066 026	1070066 081	1070066 082
EMC manual	1070066 072	1070066 074	1070066 075	1070066 076
External load switching module EBX	1070066 077	1070066 080	–	–

Release

- The current software release number can be viewed by selecting parameter S-0-0030 with the DSS-D Commissioning and Service System, or in the "Software" field of the module configuration display (DIAGNOSTICS ► MODULE CONFIGURATION).
- For information concerning the current DSS software release, refer to HELP ► ABOUT...

Safety instructions

- The current VM..B,C,D,F software release can only be read from the 7-segment display during test operation. For this purpose, turn dip switch "T" on the VM's personality module "on":

The following appears in a running, flashing display:
"Cxx.ZZ.ddmmyyyy"

Where: **xx** = software release number
ZZ = (internal)
dd = software creation day
mm = software creation month
yyyy = software creation year

Trademarks

All trademarks of software installed on Rexroth products upon delivery are the property of the respective manufacturer.

Upon delivery, all installed software is copyright-protected. The software may only be reproduced with the approval of Rexroth or in accordance with the license agreement of the respective manufacturer.

MS-DOS® and Windows™ are registered trademarks of Microsoft Corporation.

PROFIBUS® is a registered trademark of the PROFIBUS Nutzerorganisation e.V. (user organization).

SERCOS interface™ is a registered trademark of Interessengemeinschaft SERCOS interface e.V. (Joint VDW/ZVEI Working Committee).

Switch cabinet structure

2 Switch cabinet structure

2.1 Drive components

Line wiring module Type NV

The NV comprises mains contactor, fuses and mains filter. The mains voltage of 3 x 400...460 VAC is directly connected to this module.

The mains filter is a necessary interference suppression measure as specified in the EMC Directive (89/336 EEC). Thus, limit class A (B on request) for radio interference in accordance with EN 55 011 (VDE 0875) is complied with.

Stand-alone inverter type DS...K

The stand-alone inverters comprise the supply module and the drive output stage in a single housing. They are directly connected to 3 x 400...460 VAC by means of the line wiring module.

The stand-alone inverters drive Bosch servo motors type SF and SR as well as asynchronous standard motors and special motors, such as high-frequency spindles, built-in motors or linear motors.

24 V load power supply unit

The DS must be supplied from an external 24 VDC load power supply unit in accordance with EN 61131 (mean value 20.4 – 28.8 V).



CAUTION

Overvoltage!

The 24 VDC must satisfy the 'safety separation' requirements. The requirements in accordance with the overvoltage category III should be noted on the primary side !

In the inverters, the extra-low-voltage circuits are safety-separated from the mains circuit (safety separation to EN 50178).

Switch cabinet structure

2.2 Installation compartment

The ServoDyn D inverter modules are installed in a switch cabinet. Their component depth is fairly low, i.e. 270 mm or 290 mm, depending on the mechanics.

The switch cabinets must at least conform to the IP 54 protection standard (dust filter in front of the air inlet and air outlet).

The inverters are mounted in a vertical position with the terminals to the bottom.

The cooling air flow passes through the modules from the bottom to the top and must not be obstructed by other switch cabinet components or parts. In addition, a minimum clearance of 100 mm should be provided both above and below the inverter.

No minimum lateral clearance need be provided.

The air temperature inside the cabinets may be between 0...+55 °C (de-rating above 45 °C).

+55 °C is the maximum permitted supply air temperature for the uppermost inverter if several inverters are stacked one above the other.

Constructive measures have to be taken to ensure the appropriate air flow direction in the switching cabinet in this case.



CAUTION

Danger for product!

The ambient air must be free from high concentrations of dust, acids, alkalis, corrosives, salts, metal vapors etc.

Condensation on the modules is not permitted!

Condition in direct environment

For safety separation, the requirements of pollution degree 2 must not be exceeded.

For a definition of the pollution degree, refer to HD 625.1 and EN 50178.

Switch cabinet structure

2.3 Layout of the drive components

The following points must be considered in the layout of the drive components:

- Space requirements:
Depth = 288 mm,
Width = 50 mm grid,
Height = 452.5 mm,
600 mm provides clearance for ventilation
- The line wiring module is mounted on the left-hand side.
- All stand-alone inverters are positioned to the right of it.
- The power cables and control lines should be separately laid to ensure EMC (distance >100 mm). The following scheme can be adopted in the case of larger cabinets:

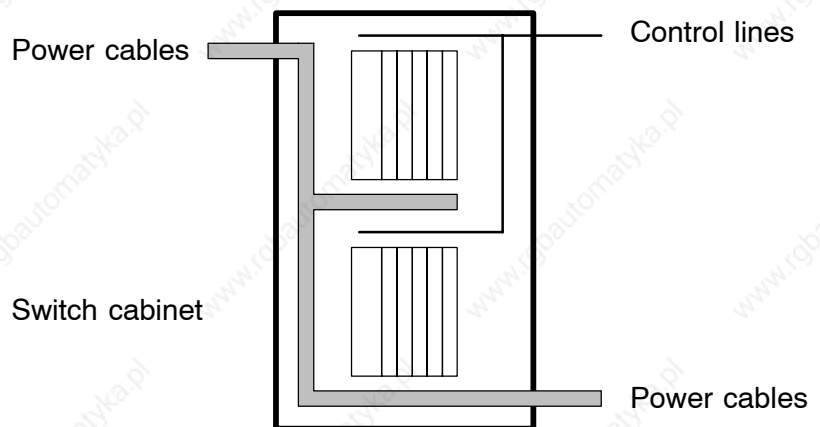

- The mains supply cable is connected to the top side of the NV module.
- The motors' power cables are connected to the bottom side of the module. They should enter the switch cabinet from the bottom.
- Control lines to the modules' front connectors are led upward into a cable duct on the top side of the inverter module.
- All drive components and electronic components such as CNC or PLC components should be arranged separately (distance > 100 mm).

Switch cabinet structure

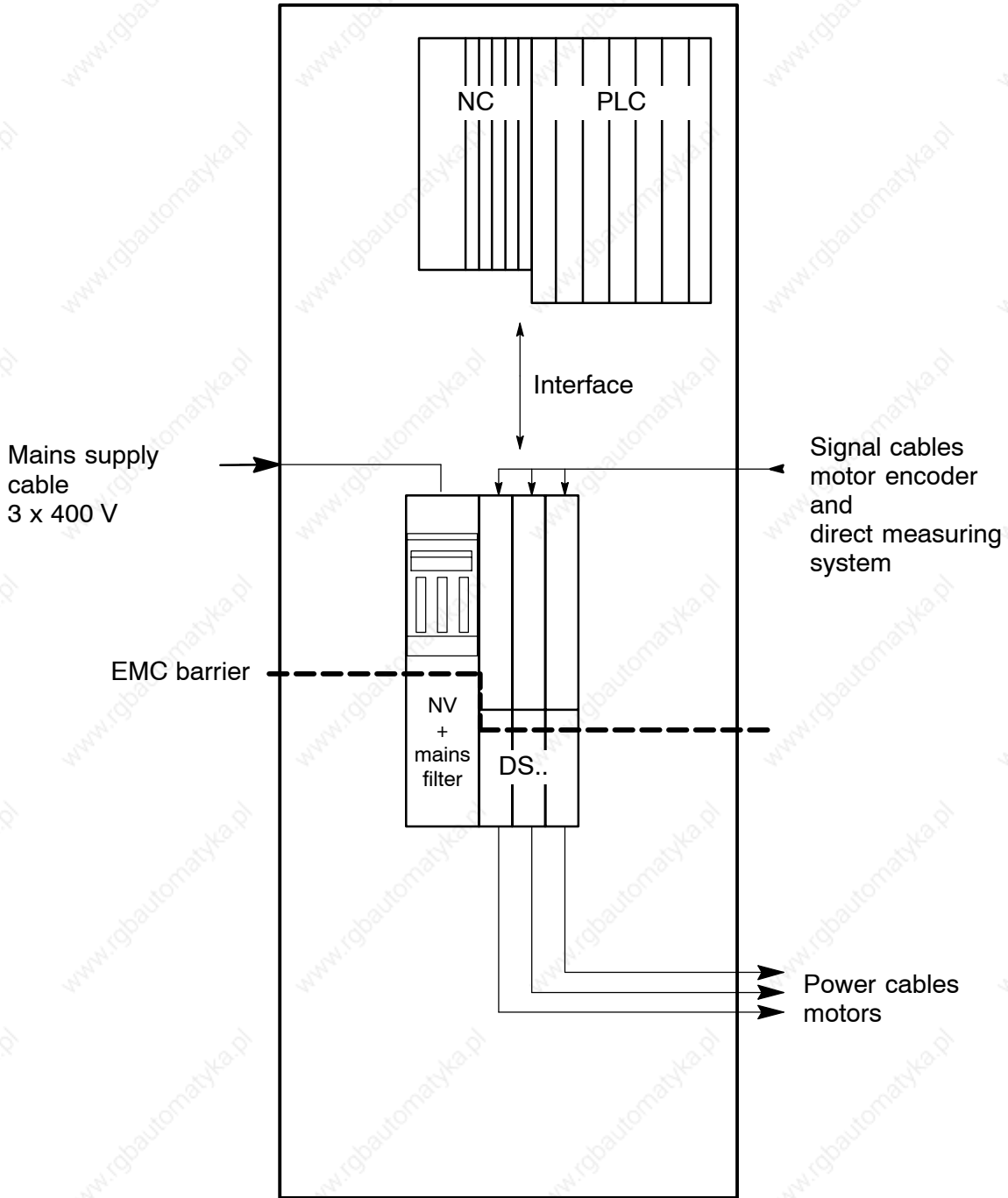

Basic switch cabinet structure, example of a possible layout

Switch cabinet structure

2.3.1 Installation in compliance with UL/CSA



A UL/CSA certification for the U.S. and Canada is available for a large number of ServoDyn D inverter types. These modules are listed in the “Product Identity 23 MB”, File No. E214694.

☞ For available components with UL/CSA approval, refer to “Servo-Dyn D, Configuration manual”, part number on page 1–7.

Installation in compliance with UL/CSA

In order to obtain a UL/CSA-compliant installation, the following must be noted in addition to the use of the certified components:

- Systems may only be used in environments with pollution severity 2.
- Observe the tightening torques on the connection terminals.
- The insulated copper wires must be specified for 60/75°C as a minimum.
- Only use insulated cable of class 1 or equivalent, e.g. according to UL Style 1015 (on motor side, H07: U₀/U: 600/1000 V) and UL Style 1007 or 1569 (on mains side, H05: U₀/U: 300/500 V)
- Suitable for installation in symmetrical supply networks with a short-circuit current of ≤ 10 kA with max. 460 V +10 %.

Operation in compliance with UL/CSA

For UL/CSA-compliant operation, the bimetal function (I²t monitoring) must be activated in the inverters using parameter P-0-0053 in order to provide motor protection:

- I_N of the motor is automatically retrieved from the electronic rating plate to the I²t- monitoring function.
- P-0-0053 is only used to set the desired time constant:
Factory setting: 0.0 (deactivated)
Normal setting range: 100...150
(corresponds to release characteristics of bimetal relay)

Switch cabinet structure

Notes:

Installation

3 Installation

3.1 Layout and mounting position

All inverter modules are installed in a vertical position with the terminals to the bottom. They should be connected on a level metal surface using two or four screws or bolts depending on size. The recommended size is M5. A conductive connection to the mounting surface must be established via the screws or bolts.

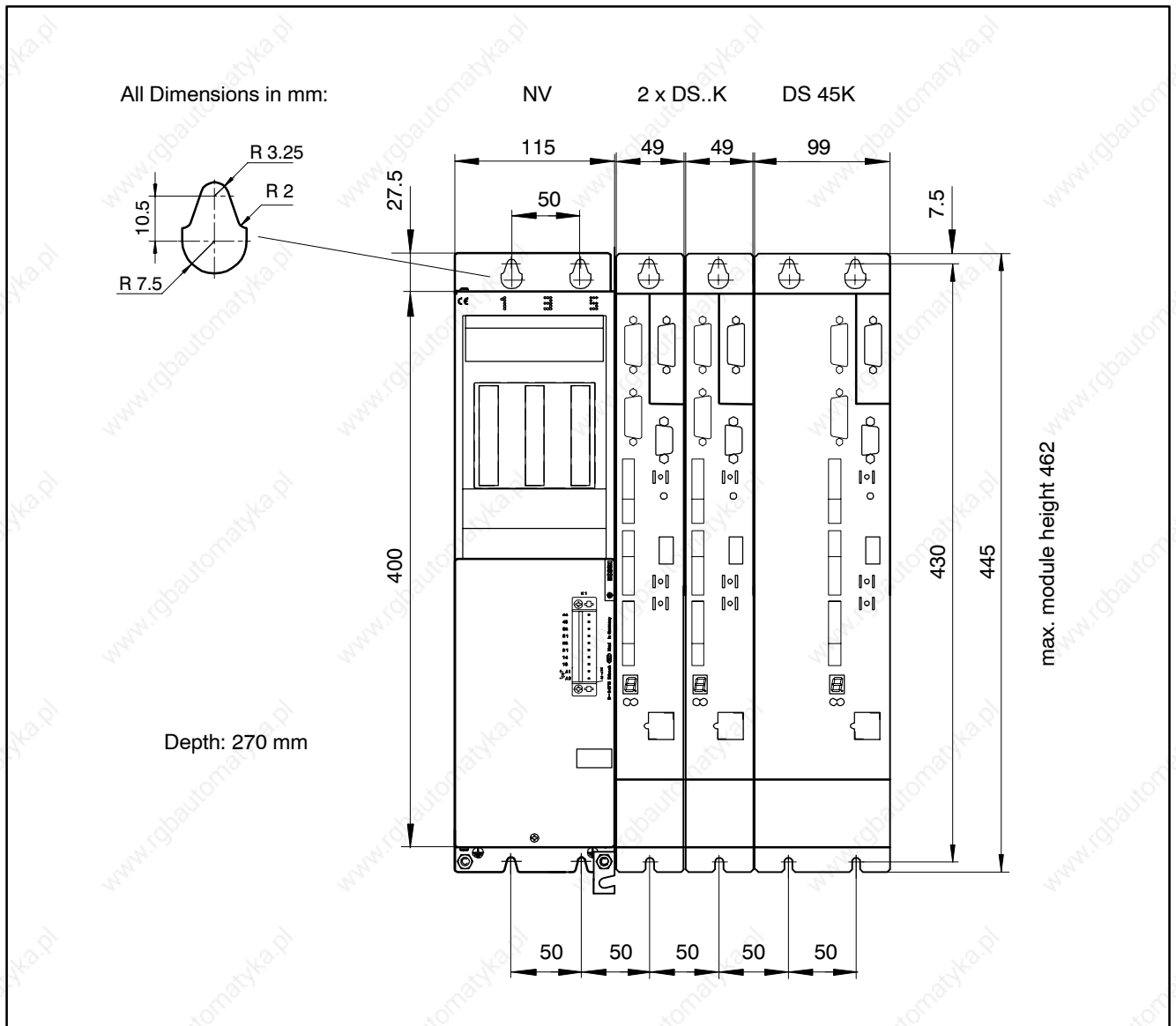

Installation

3.2 Protective earth connection between the modules

★ A protective earth connection between several DS inverters is made using an earth bar at each DS module:

1. Release screws of pre-assembled protective earth bar at the module front side, push bar below the fastening screw of the adjoining module to the left.
2. Reinstall the protective earth conductor bar.

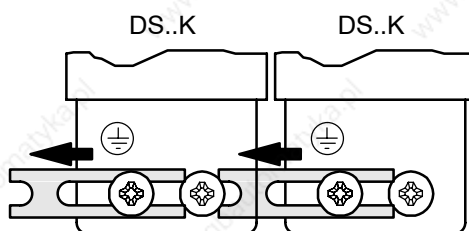

3.3 Connection cables

The power cables leading to the terminal block should be combined with strain relief.

Logic cables to the front connectors and power cables must not be laid together. They may be installed above the inverter module in a cable duct.

**CAUTION**

To protect the power unit from destruction, the tightening torque for the power connections U, V, W must not exceed 3 Nm.

Connection overview

4 Connection overview

4.1 NV and DS..K with analog interface

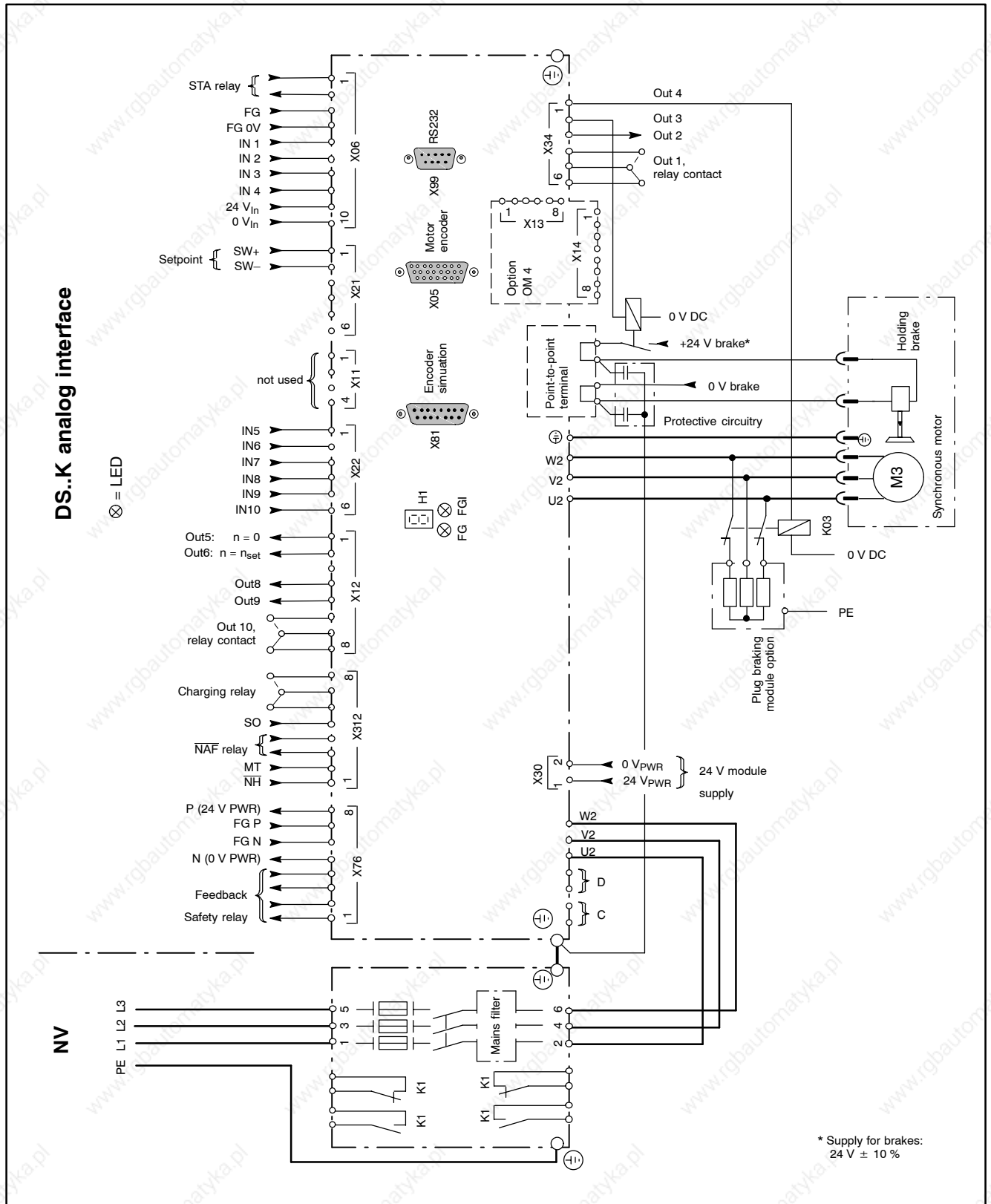

Connection overview

4.2 NV and DS..K with Motion Control

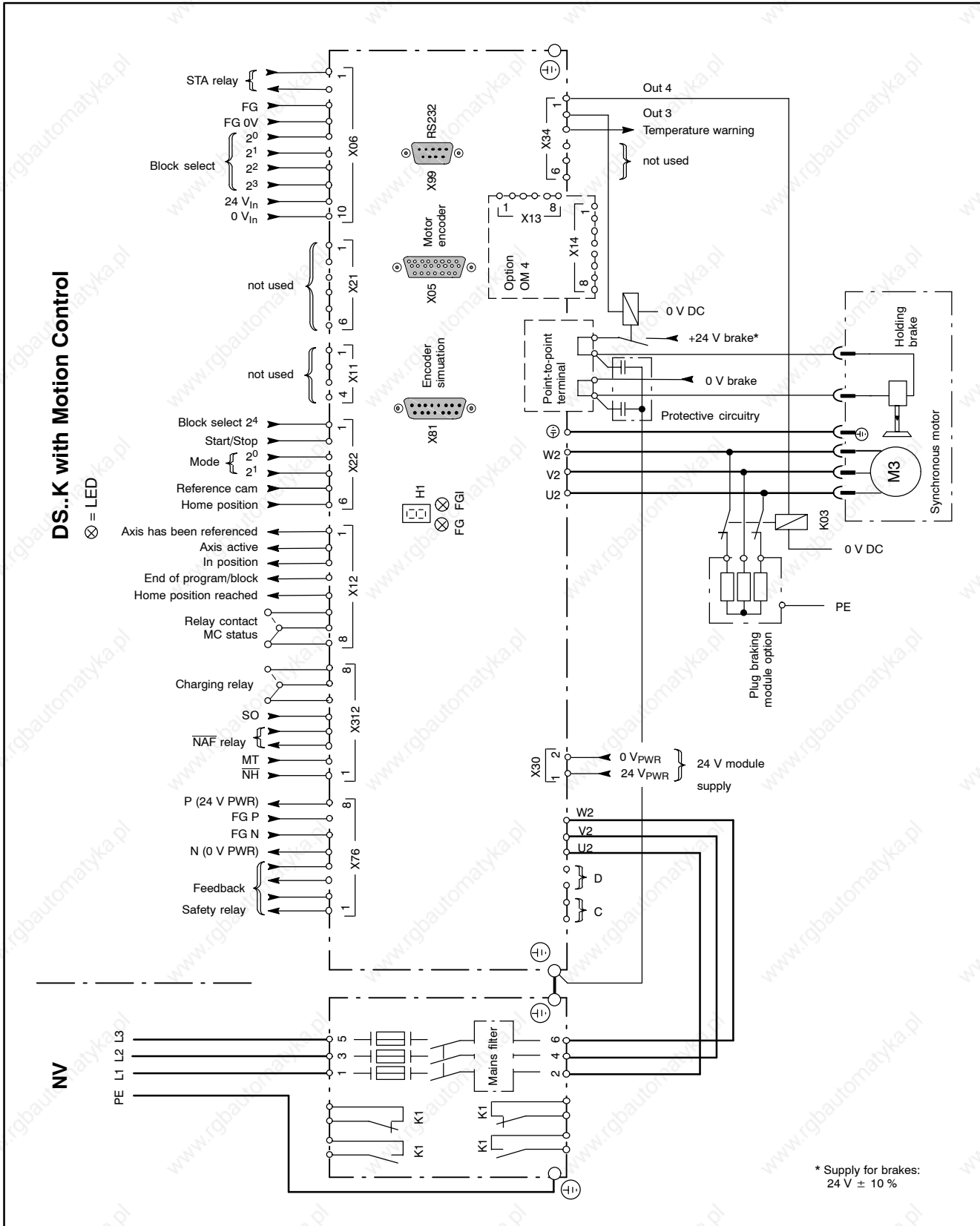

Connection overview

4.4 NV and DS..K with SERCOS interface

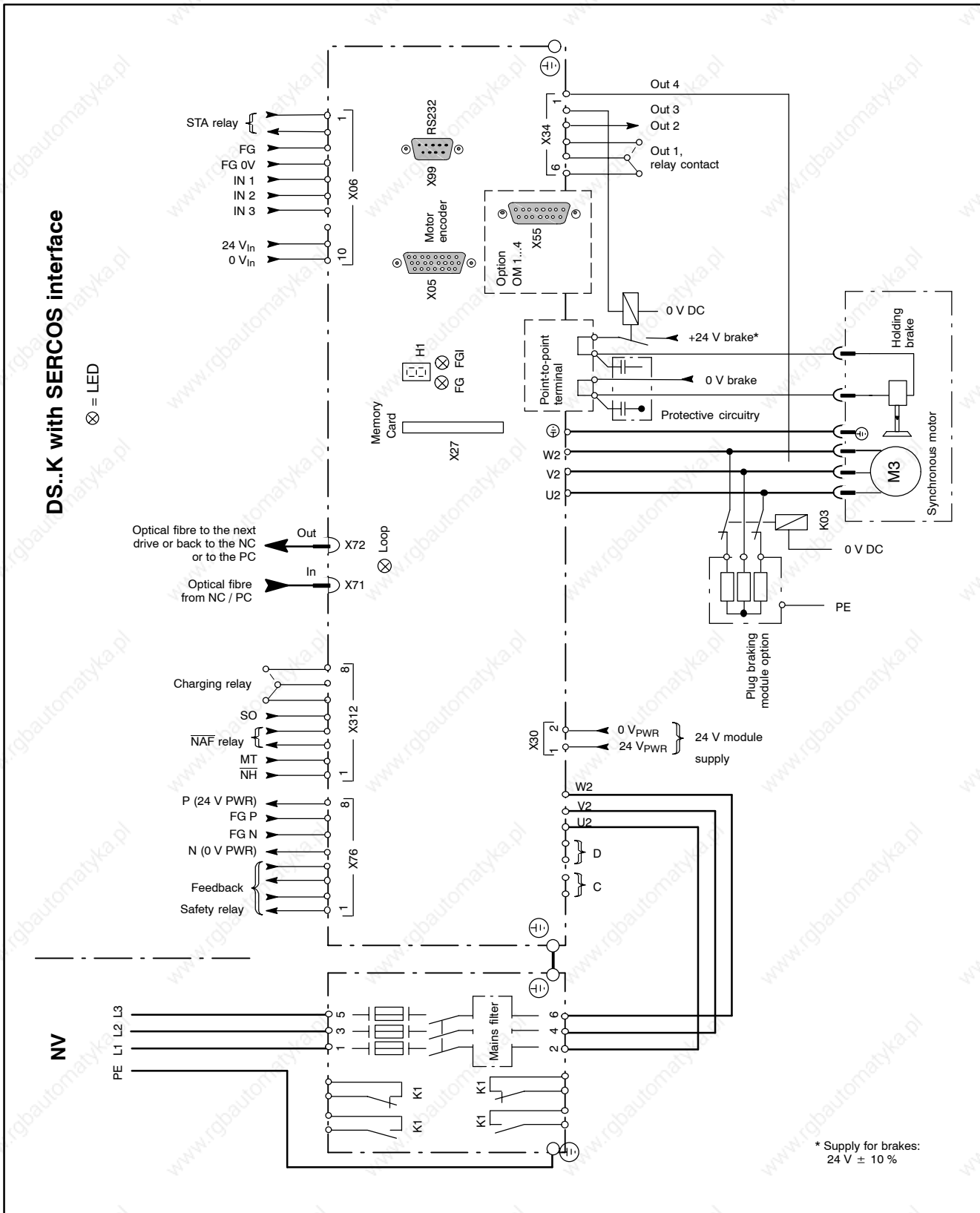

Connection overview

4.5 NV and DS..K with CAN bus

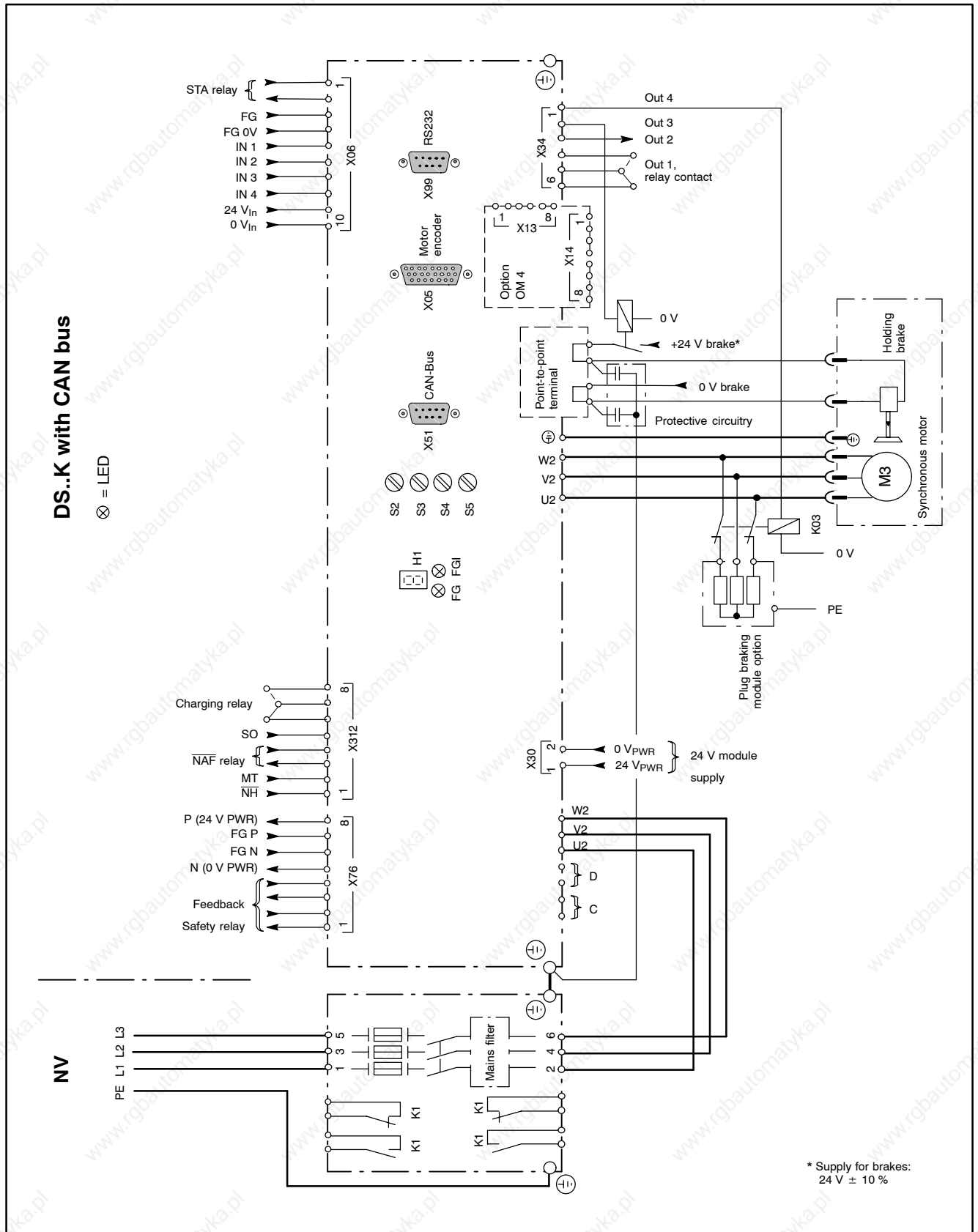

* Supply for brakes:
24 V ± 10 %

Connection overview

4.6 NV and DS..K with PROFIBUS-DP

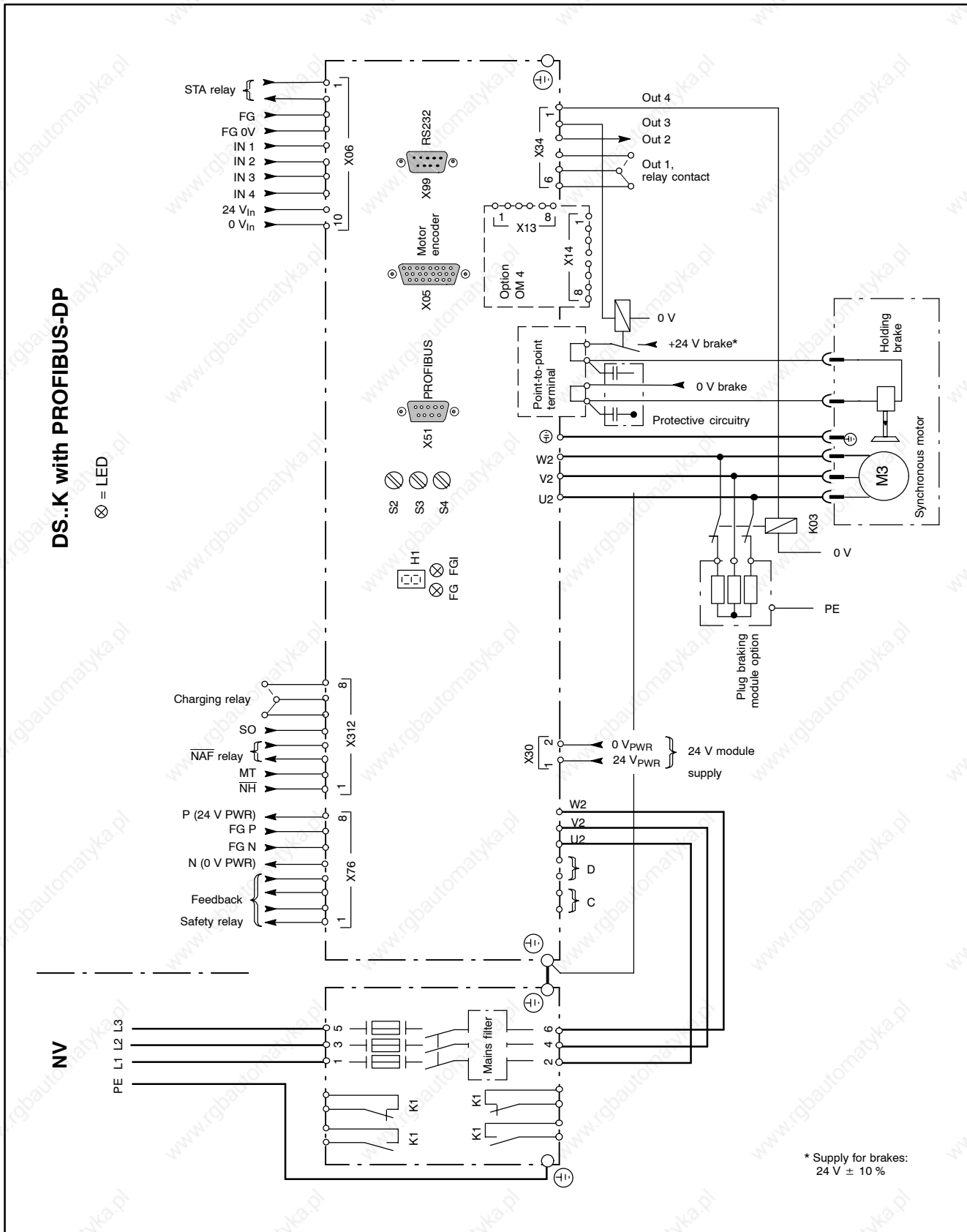

Power connection

5 Power connection

5.1 Earthing



CAUTION

Inverter modules may only be operated with an earthed neutral system.

Systems not directly earthed (IT protective system) must not be used for operation, as air clearances and leakage paths in the module may be overloaded.

Operation at asymmetrical mains systems (TT protective system, one mains phase is earthed) is not permissible!

DIN VDE 0100-300 defines mains systems subject to their type of earth connection.

Accordingly, in an IT protective system, all active parts are separated from earth, or one point is connected to earth via a resistor.

The exposed conductive parts of an electrical system are either

- earthed separately, or
- earthed jointly, or
- jointly connected to the system earth.

☞ Please note the information on earthing in the ServoDyn D EMC manual, for part no. refer to page 5-3.

Protective earthing of inverters



DANGEROUS ELECTRICAL VOLTAGE

The only permissible protective measure in accordance with EN 50 178 is a protective earth connection.

The protective conductor must at least have the same area as the mains feeder.

Earthing only one end of the DC link when operating by means of an isolating transformer is prohibited!

Earth connections in the switch cabinet must be designed in the form of a grid mesh.

The inverter housing and mounting plate of the switch cabinet must be earthed. The connection between the line filter and the inverter should be as short as possible.

The protective earth cross-section must at least correspond to the cross-section of the line feeder.

Power connection

**DANGER**

Dangerous shock currents through inappropriate protective earth connections!

Do not impair protective earth connections by mechanical, chemical or electro-chemical influences. The connection must be firm and lasting.

Several stand-alone inverters are interconnected using the pre-assembled earth bars (cf. section 3.2).

For connection to the PE bar, one of the fastening screws of the earth bar may be used.

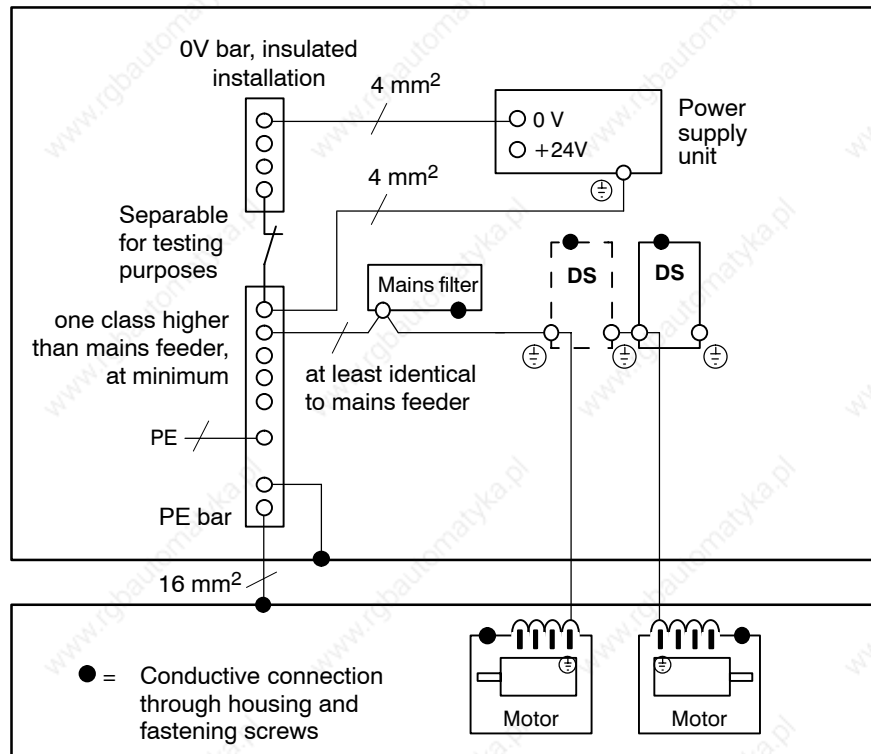
**Protective earthing of motors**

In accordance with DIN VDE 0160, the protective earth conductor cross-section must be rated for $\sqrt{3}$ times the rated load of the power conductors.

If at least two motors are used by the machine which are connected to each other via the housing, the PE conductor cross-section has grown accordingly in size and the condition mentioned above is satisfied.



For stand-alone inverters, the earth conductor of the motors is fitted with a cable lug and squeezed under the fastening screw of the earth bar.

Power connection

PE bar

The cross-section of the PE bar and mounting plate earth conductor must be selected one size bigger than the line feeder of the supply module.

24 V power supply unit

The PE connection and the secondary circuit earthing (non-isolated) must be designed in accordance with the secondary current, but must have a cross-section of at least 1.5 mm².

0 V bar

The 0V bar must have an insulated structure and may be earthed in a single point only.

This measure is designed to avoid 24V operating currents in the earth and shield connections.

5.2 Electromagnetic compatibility (EMC)

 Please note the information given in the ServoDyn D EMC manual:

Language	Part no.
German	1070 066 072
English	1070 066 074
French	1070 066 075
Italian	1070 066 076

Power connection

5.3 Earth-leakage circuit-breaker

Inverters incorporate switched power units which are always associated with capacitive leakage currents against earth. The leakage currents may depend on the number of inverters, the earthing conditions as well as the design and length of motor power cables.

Mains filters and shielded cables used to improve the electromagnetic compatibility (EMC) increase the leakage currents further. For this reason, no earth-leakage circuit-breakers with nominal leakage currents of less than 300 mA may be used.

**DANGEROUS ELECTRICAL VOLTAGE**

Personnel protection is only guaranteed if earth-leakage circuit-breakers with nominal leakage currents of less than 30 mA are used.



Inductors and/or capacitors present in the electric circuit may lead to spurious trips. If radio interference suppression filters are used, spurious trips can only be avoided by installing an isolating transformer.

**DANGEROUS ELECTRICAL VOLTAGE**

If a pulse power current sensitive e.l.c.b. type A in accordance with IEC-755 (VDE 0664) is used, its protective function is not guaranteed for inverters with a 3-phase mains connection (B6 circuit).

The protection of all electrical components connected together with inverters with a 3-phase mains connection to a pulse power current sensitive e.l.c.b. may be adversely affected.

Therefore, you should either install an isolating transformer with a protective device and earthing in the mains feeder, or use a universal current sensitive e.l.c.b. type B which also provides safety disconnection in the event of DC leakage currents.

Power connection

5.4 Mains supply



DANGEROUS ELECTRICAL VOLTAGE

The only permissible protective measure in accordance with EN 50 178 is a protective earth connection.

The protective conductor must at least have the same area as the mains feeder.

Earthing only one end of the DC link when operating by means of an isolating transformer is prohibited!



CAUTION

Inverter modules may only be operated with an earthed neutral system.

Systems not directly earthed (IT protective system) must not be used for operation, as air clearances and leakage paths in the module may be overloaded.

Operation at asymmetrical mains systems (TT protective system, one mains phase is earthed) is not permissible!

The mains system is connected using a plug at the bottom side of the housing, usually via a mains filter.

DS 15K



Power connection

DS 45K

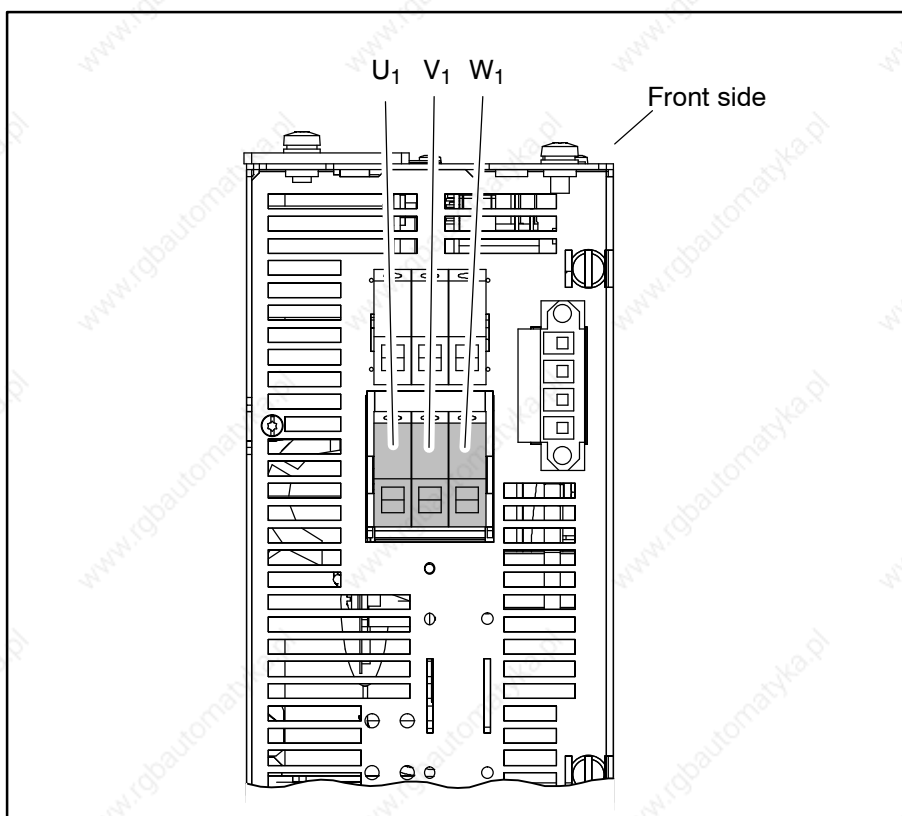

- Supply voltage $U = 400 \dots 460 \text{ V} \pm 10 \%$, 48...62 Hz
- The power electronics are excluded from the admissible total supply voltage dip for max. 10 ms required under EN 60204. Upon mains failure, the drive is switched off and an error message is output.
- Voltage peaks: Between conductors $\cong 1 \text{ kV}$
Conductor to ground $\cong 4 \text{ kV}$
- The lightning protector which limits the transient overvoltage to 4 kV is a prerequisite in the sub-distribution. All air clearances and leakage paths are designed for 4 kV (conductor to ground impulse withstand voltage).
- The power connection is designed in accordance with the requirements laid down in overvoltage category 3.

Power connection

Autotransformer

If the actual mains voltage is not identical with the specified supply voltage, an isolating transformer or an autotransformer with the following specifications may be used:

3-phase autotransformer to UL standard for inverter input	DS 15K	DS 45K
Inverter clock frequency	max. 8 kHz	
Output	5 kW	12 kW
Primary voltage	actual mains voltage	
Secondary voltage	3 x 400 V	
Secondary current	12 A	30 A
Short circuit voltage uk	1.5 %	
Protection standard	IP 00	
Insulation class	H/40	

Power connection

5.4.1 Connection via NV line wiring module

 **UL class 1 power cables (e.g. UL Style 1007 or 1569 on mains side, H05: U₀/U: 300/500 V) have to be used for UL/CSA-certified drive inverters.**

This is to ensure that the entire system meets the UL/CSA requirements.

If connected via the NV line wiring module with integrated mains filter, compliance with RFI suppression limit class A to EN 55011 (VDE 0875) is guaranteed.



CAUTION

In a discrete system, the mains filter must be installed between the mains contactor and the inverter in order to protect the inverter from damage.

NV line wiring module



* According to EN 60204 Part 1/1993, Tab. 5 for installation in the cable duct at an ambient temperature of 45°C

Power connection

Back-up fuses in special designs (encapsulated fuses) are used in NV modules with UL certification. They must not be used in standard modules without UL certification and vice versa.

Low-voltage supply for DS..K xxx2

Use low voltage < 60 V for set-up operations. This voltage may be generated, e.g., by an autotransformer.

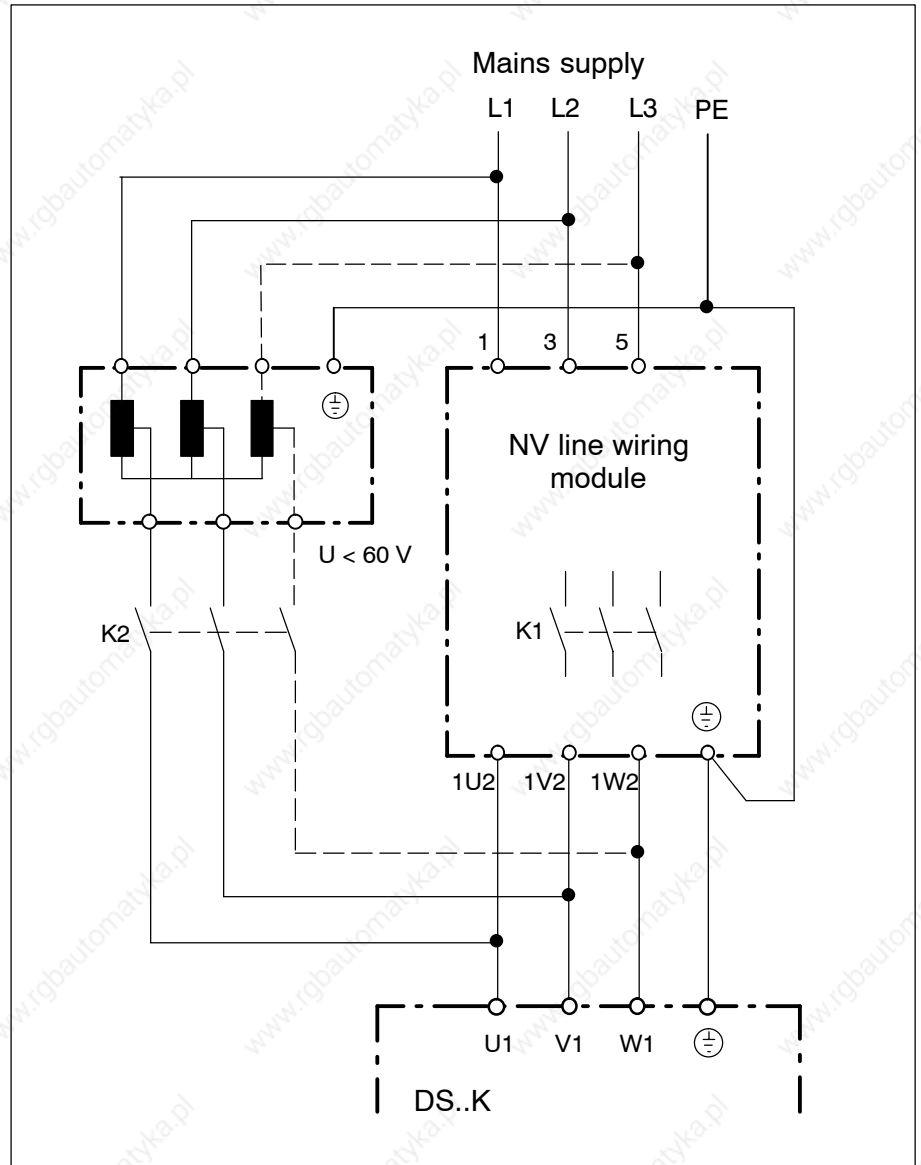

Power connection

5.5 24 V supply

The supply modules require a 24 V supply from an external 24 VDC load power supply module in accordance with EN 61 131 (20.4 – 28.8 V). A stabilized power supply unit is not required.

The input terminals are protected against polarity reversal.

The 0 V_{PWR} connection is internally floating against ground. If the 0 V are to be grounded, the ground connection has to be made, e.g., at the external 24 V power supply unit.



DANGEROUS ELECTRICAL VOLTAGE

The 24 VDC must satisfy the 'safety separation' requirements. The requirements in accordance with the overvoltage category III should be noted on the primary side!

In the inverters, the extra-low-voltage circuits are safety-separated from the mains circuit (safety separation to EN 50178).



CAUTION

Contact system destroyed!

Connector X30 may only be inserted or removed while the unit is disconnected from power. Furthermore, the connection screws have to be firmly tightened. Use a screw driver with a blade size 0.6 x 3.5 for this purpose.



DANGER

The drives coast to a standstill if the 24 V supply is interrupted! This can be avoided by taking one of the following measures:

- use a buffered 24 V power supply unit (no 100% safety)
- plug braking of the motors with KSB (plug braking) module
- use motors with a holding brake.

Current consumption

Module type	Current consumption 24 VDC
DS 15K	1.4 A
DS 45K	1.6 A

Power connection

5.6 DC link connection

The DC link of several stand-alone inverters can be connected via terminals X32.1, 2 (C) and X32.3,4 (D) in order to use the ballast switches of all stand-alone inverters jointly during braking. The load on the individual ballast switches is thus reduced.



CAUTION

Danger of damage to equipment!
Only link identical inverter sizes.
Do not mix DS 15K and DS 45K.

DS 15K

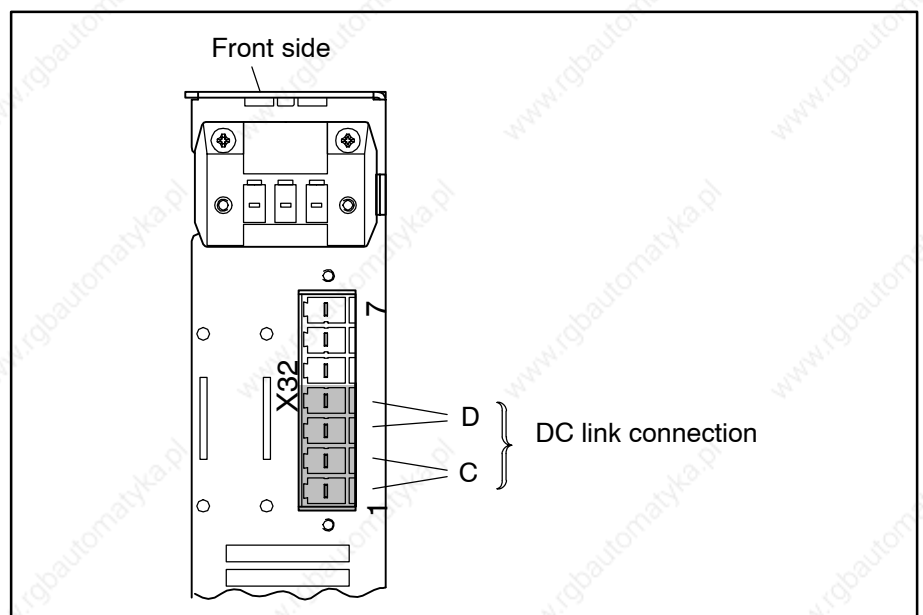

DS 45K

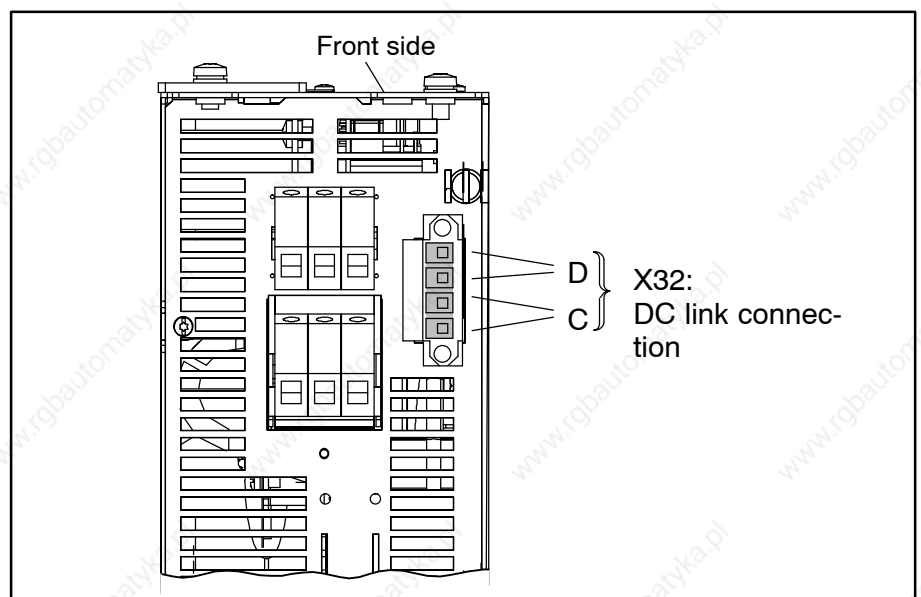

Power connection

5.7 Motor connection



DANGEROUS ELECTRICAL VOLTAGE

Due to the permanent magnet excitation, the power connector carries a hazardous high voltage if the rotor is rotating and the motor is not electrically connected!

The unit must be completely de-energized and halted before commencing any connection or installation work.

Motor cables

We recommend using prefabricated Bosch motor cables for the SF and SR servo motors. Depending on the individual case, these cables are available as

- Standard cables, shielded
- Standard cables, unshielded
- UL power cable

☞ **UL class 1 power cables (e.g. UL Style 1510 on motor side, H07: U_0/U : 600/1000 V) have to be used for UL/CSA-certified drive inverters. This is to ensure that the entire system meets the UL/CSA requirements.**



CAUTION

Damage to cables due to inadmissible movements.

Please note the technical data of the cables specified in the “Configuration manual”, part no. on page 1–7.

Cable bushing (metal flange)

For cable bushings, e.g. leading into the switch cabinet, a metal flange may be used in connection with a cable extension and a coupling. The connector housing is clamped and sealed to IP 65 when installed.

Flange: Zinc diecasting, nickel-plated

Gasket: Viton, black



Power connection

5.7.1 SF, SR servo motors power and brake connection



CAUTION

Damages at the inverter or encoder by inserting or removing plug-in connections on live systems!

Switch the drive off beforehand.

☞ Please note that unshielded motor cables may inject voltages into other cables laid in parallel due to capacitive injection mechanisms.

Noticeable voltages are particularly injected in unused brake cores. In accordance with IEC 1201, the line capacitance is not sufficient to generate lethal voltages (at a cable length of 100 m approx. 15 nF between cores, a dangerous value would be 28 nF at 400 V). Insulate the open ends of the brake cores.

If cables are laid in parallel, injection is approx. 10 times lower. Shielded motor cables do not produce injections.

Due to the mains pollution caused by shielded motor cables, the permissible length of the motor cables is limited depending on the mains filter of the NV module used.

NV with class A mains filter	Part no.	Maximum total length of shielded motor power cables
NV 20/1F	1070 078 431	25 m
NV 20/1VF	1070 084 594	150 m
NV 21/1F	1070 084 067	25 m

Power connection

DS 15K

Motor connection using plugs at the bottom side of the housing.

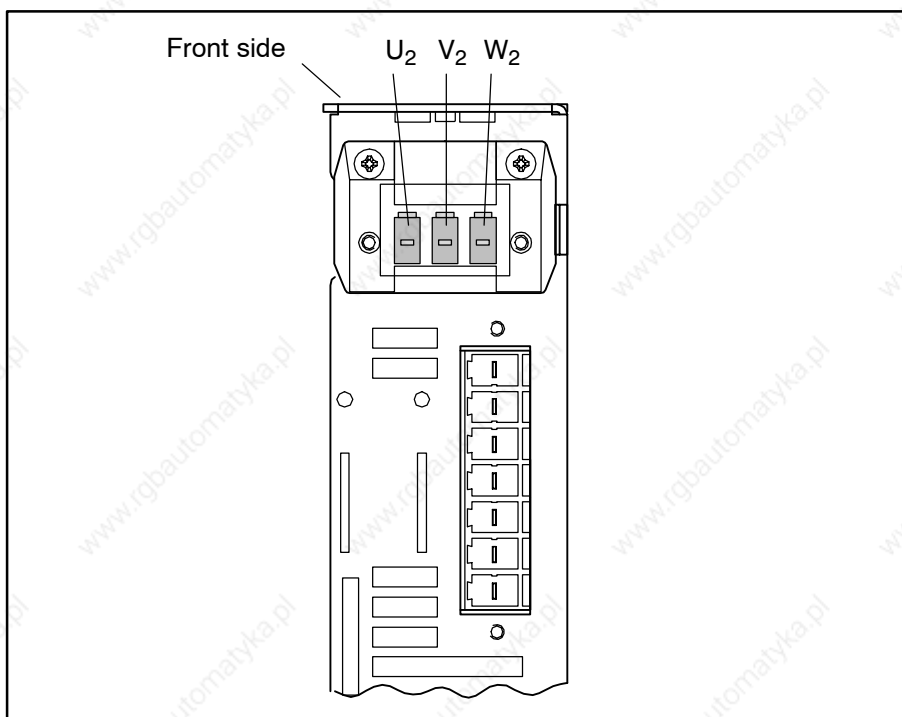

DS 45K

Motor connection using terminals at the bottom side of the housing.

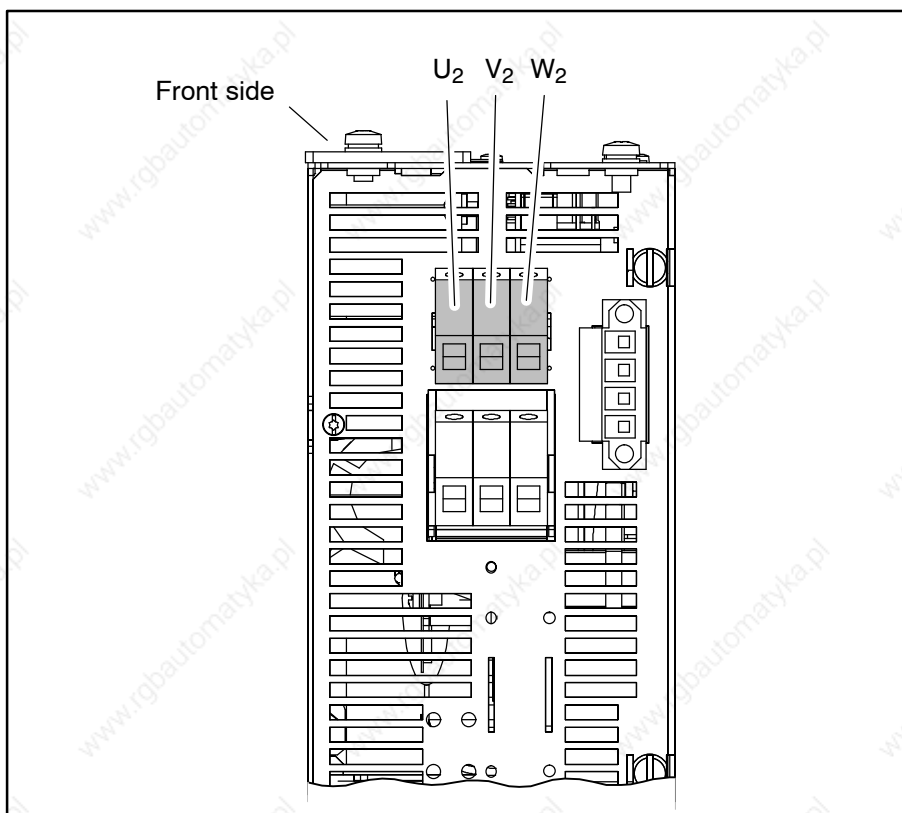

Power connection

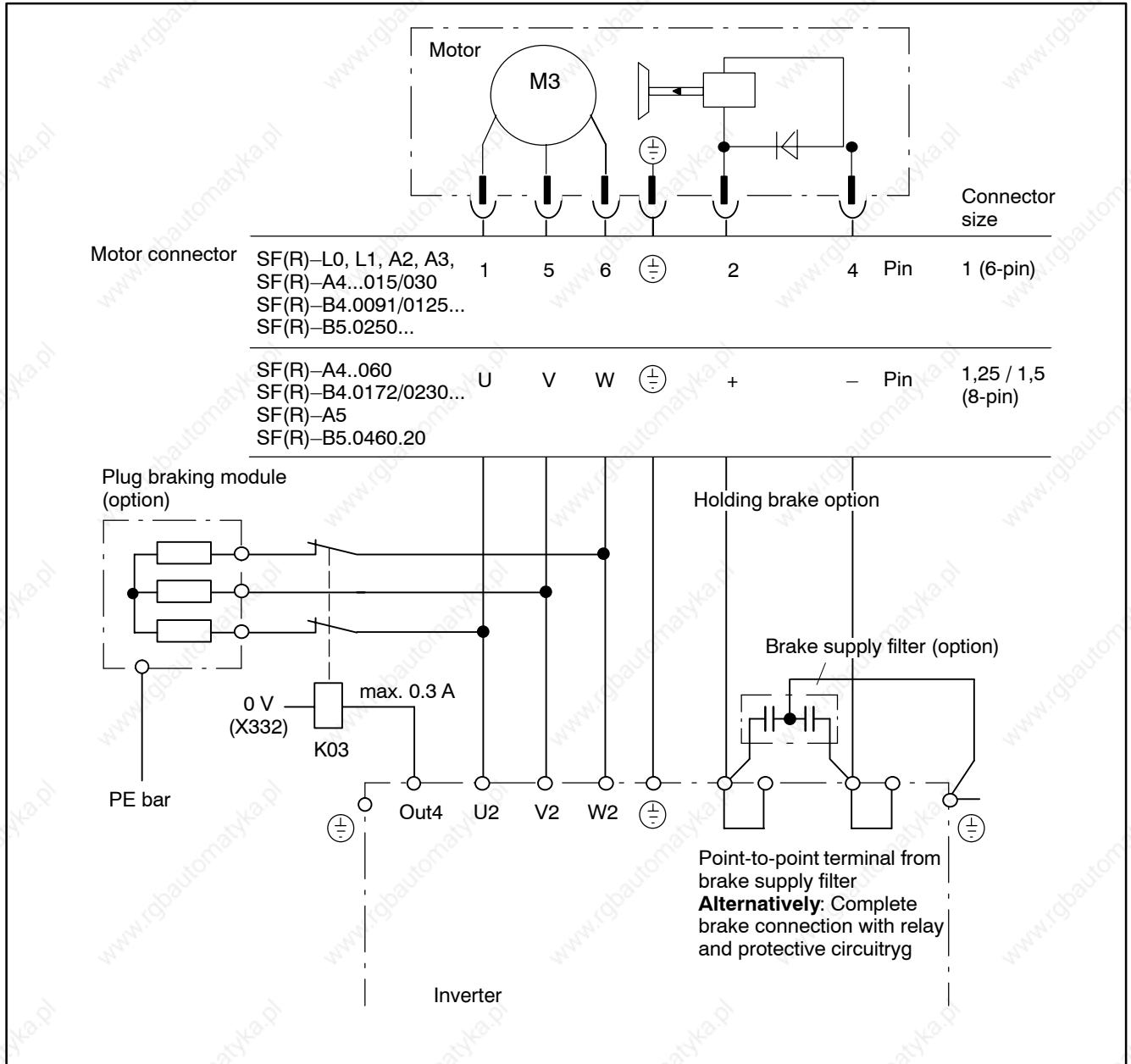

Rated voltage of the motor power cables:
 $U_0/U = 600/1000 \text{ VAC}$.



DANGEROUS ELECTRICAL VOLTAGE

Motor leads and brake leads are led in a multi-conductor cable. The cores of the brake lead must have the same insulation as the cores of the motor lead ($U_0/U = 600/1000 \text{ VAC}$). If no holding brake is connected, the open ends of the brake lead must be insulated!

☞ **For connection cross-sections and more information on the leads, please refer to the “Configuration” and “SF, SR servo motors” manuals.**

Power connection

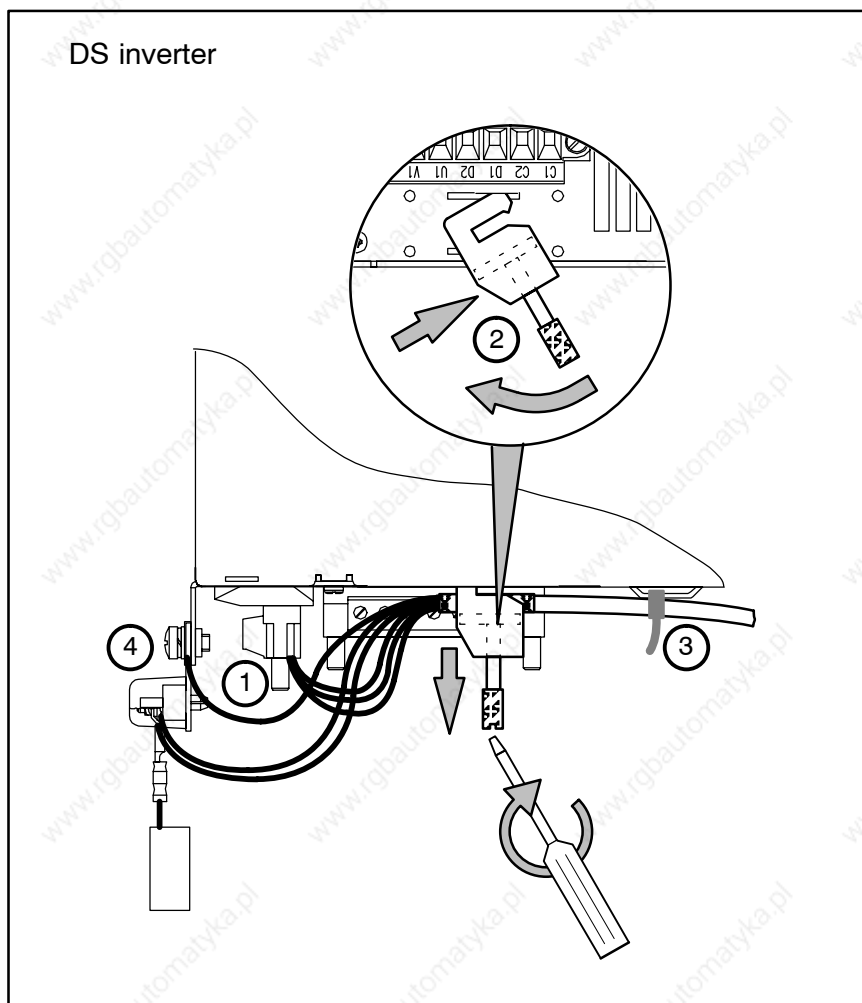
Shield connection to the DS..K

1. Connect power cables with connector ① on bottom side of housing.

2. Insert shield connection link ② into mounting slots on the bottom side of housing and push backwards until the stop.



The shield connection link is preferably inserted towards the back side, as shown. The room available for cable routing is limited in the DS inverter due to the additional connector in the front area.

3. Tighten link on the strapped shield end of the cable.

4. Fasten motor cable with cable strap ③ at bottom side of housing.

5. Finally make the PE connection ④.

The following can be installed for brake supply:

- protective circuitry with point-to-point terminal (cf. page 5-17) or
- brake connection with relay and protective circuitry (cf. page 5-18).

Power connection

Brake supply filter

Capacitive influences on the 24 V line for the holding brake may cause a delay in the brake disengagement. In order to avoid such interferences, please use the brake supply filter designed for this purpose.

The brake supply filter includes an additional point-to-point terminal which is to be plugged onto the module, thus providing for direct brake connection to the module.

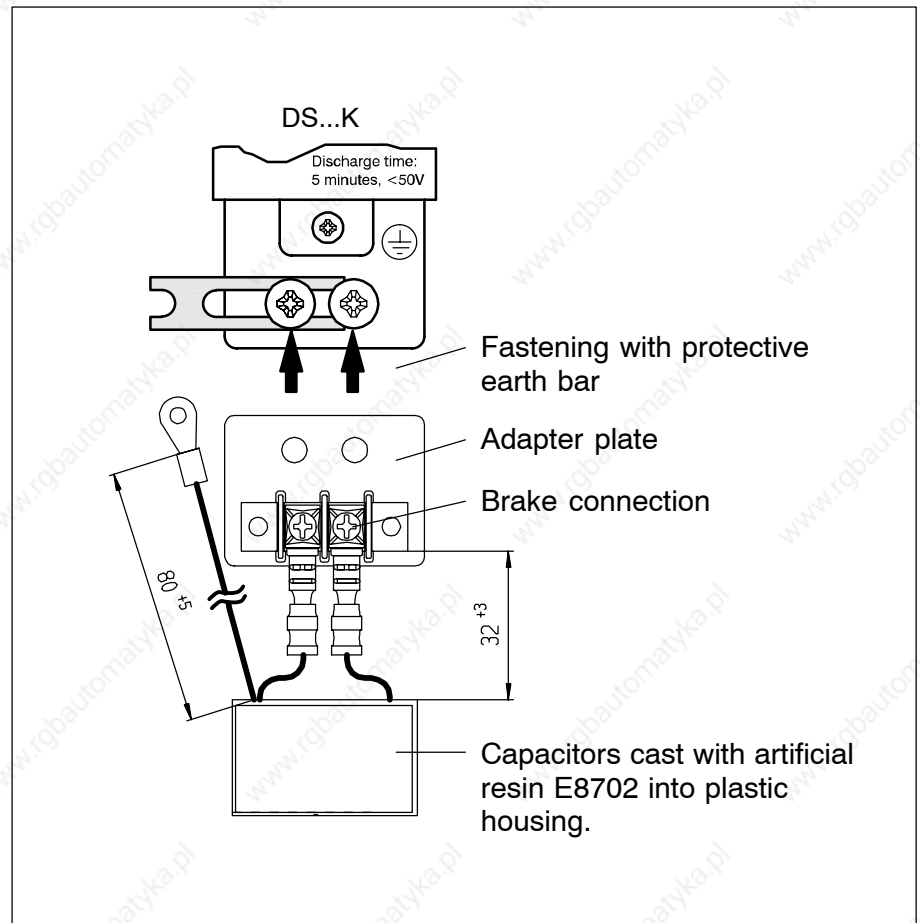

Power connection

MBC brake connection with relay and protective circuitry

These accessories eliminate interference and facilitate brake control, because they contain an additional relay.

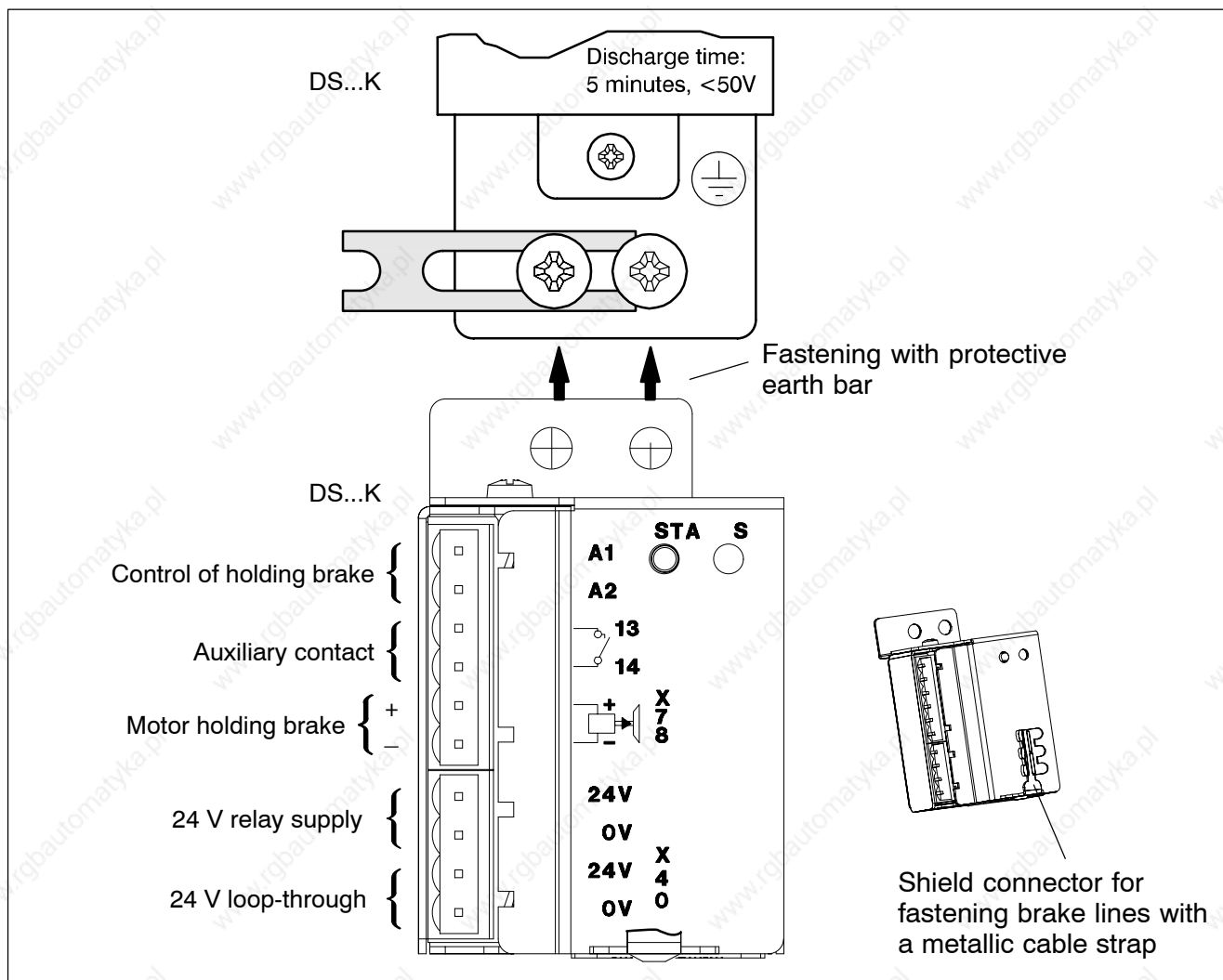

X78 A1, A2 Control

Active with +24 V.

A1: Holding brake control signal from DS, X34.2 (Out3)

A2: 0 V from VM, X332

For UL-conformant drive installations:

If A1, A2 are not controlled via the DS, the voltage supply must comply with UL Class II.

13, 14 Auxiliary contact

Freely available auxiliary contact of the control relay.

+ , - Holding brake

Connection of motor brake line.

Power connection

X40 24 V, 0 V Voltage supply

24 VDC voltage supply of the control relay.

The 24 V are looped through to the next module via the 2nd pair of terminals.

STA LED, green

The LED is on if the holding brake of the motor has been vented, i.e. when control is active.

S Key

The brake can be vented using the S key if no external control signal is present.

Power connection

5.7.2 DU asynchronous motor power connection

Motor end

The following electrical connections are made in the terminal box:

- Power
- External fan
- Holding brake option

Cable entry is through two heavy-gauge conduit threads. The terminal box is located on the top as standard and can be turned by 4 x 90°. Circuit diagram on the terminal box lid.

Module end

DS..K:

Power connection using plugs at the bottom side of the housing.

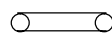
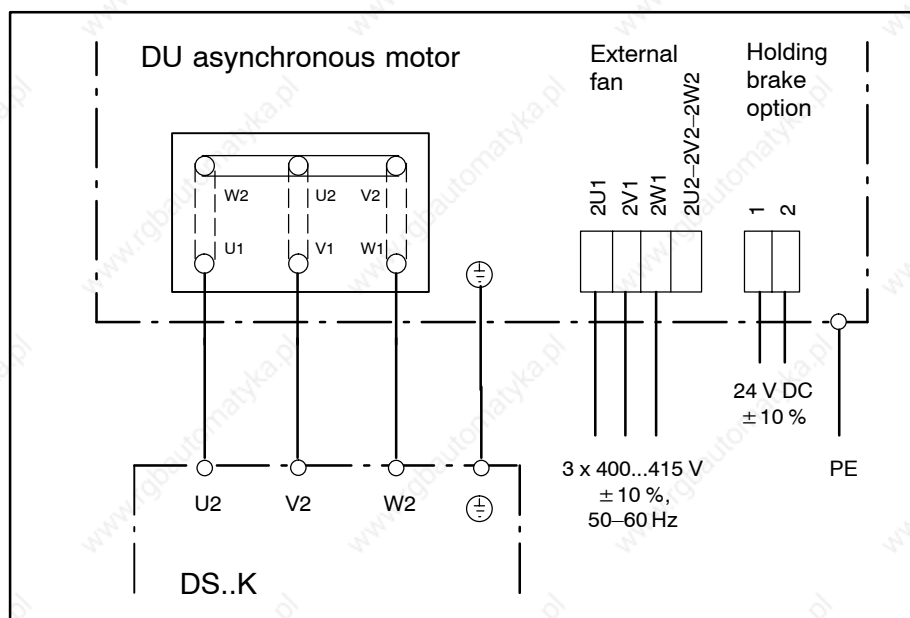

Star connection,
to be used for motors size 90



Δ connection,
to be used for motors size 100 ... 160



CAUTION

The contacts of the motor contactor may weld together if opened under excessive load!

The motor contactor may only be opened when $n = 0$ and enabling has been cancelled.

Connections on supply module

6 Connections on supply module

6.1 Overview of DS..K xxx2 (in set-up mode)

For other connections, refer to the description of the interfaces:

- Analog interface, positioning function
- frequency inverter
- CAN bus
- SERCOS interface
- PROFIBUS-DP

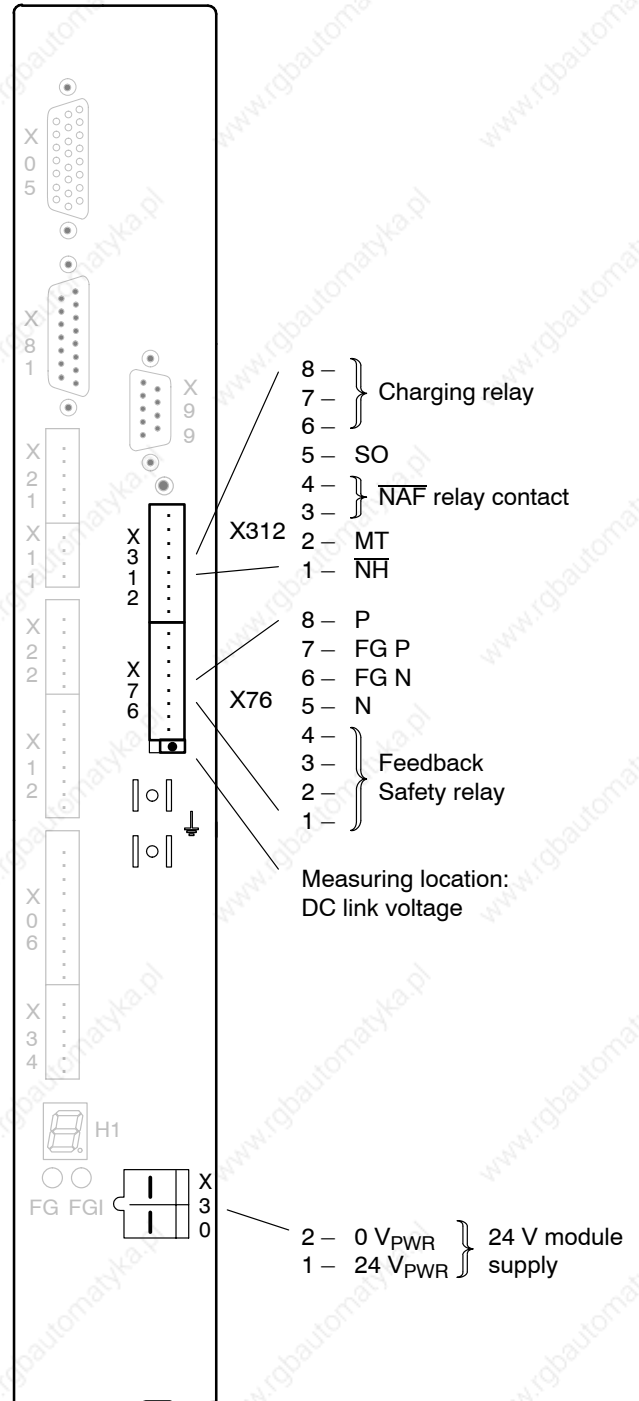

Connections on supply module

6.2 Overview of DS..K xxx1

For other connections, refer to the description of the interfaces:

- Analog interface, positioning function
- frequency inverter
- CAN bus
- SERCOS interface
- PROFIBUS-DP



Connections on supply module

6.3 Terminal strips

Terminal strip X30

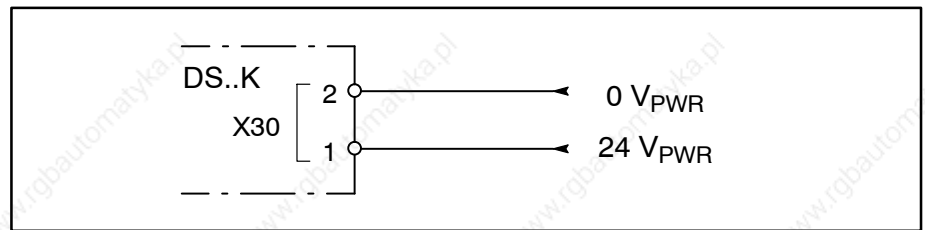

X30.1/2 24V_{PWR}, 0V_{PWR} 24 V module supply (power)

Power supply to the module is provided by an external 24 VDC load power supply unit according to section 5.5.

Terminal strip X312

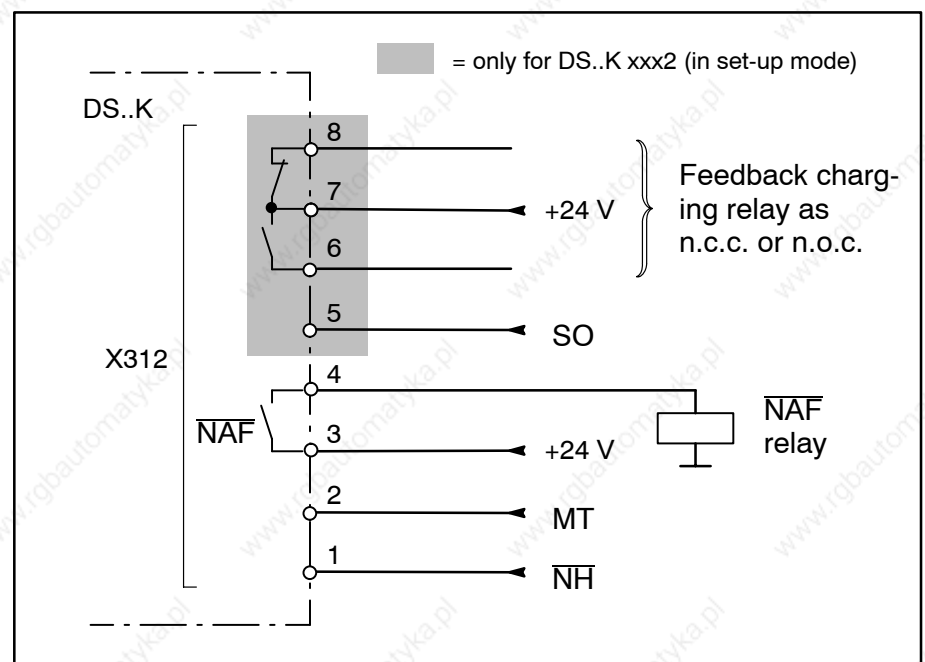

X312.1 NH Emergency-Stop (drive halt)

Optocoupler input for the Emergency-Stop function, active with 0VDC.

If this signal is LOW, the motor is halted as defined in parameter P-0-0004:

- within the shortest time possible (S-0-0138)
- drive-controlled via ramp S-0-0260
- setpoint-controlled by master
- drive-controlled via ramp P-0-0260 (for SERCOS interface only).

When halted, the torque is removed from all motors. For connection, cf. page 6-7, 6-8.

Connections on supply module

X312.2 MT Measuring probe input

Optocoupler input for the measuring probe of the machine, active with +24V.

Can be used as a setpoint interface in connection with SERCOS interface only.

The signal propagation delay between the measuring probe and the axis in question is < 5 μ s.

X312.3/4 \overline{NAF} Mains failure

Floating relay contact. Max. load 30 VDC/1000 mA.

The contact immediately opens in the event of a DC link voltage of < 450 V.

\overline{NAF} can be evaluated as a warning, e.g. for further processing by a PLC.

X312.5 SO Special mode (only for DS..K xxx2)

Optocoupler input for enable signal in set-up mode, active with 24 VDC.

To set up the machine, a reduced voltage may be supplied to the power terminals U1, V1, W1 of the inverter. It will reduce the torque of the motors to protect the operating personnel.

Applying 24V to SO will activate the inverter's internal enable signal voltage if low voltage is present.

**DANGER**

When changing over between normal voltage and low voltage, the proper making sequence must be ensured by an external interlock circuitry.

Refer to proposed circuitry, page 6-7, 6-8.

X312.6/7/8 LR_A/LR_B Charging relay feedback (only for DS..K xxx2)

Floating relay contacts. Max. load 30 VDC/1000 mA

Relay contact X312.6/7 is closed, and relay contact X312.7/8 is opened when the internal charging relay is closed in order to charge the DC link.

**CAUTION**

The rectifier unit of the inverter may be destroyed!

During low-voltage operation, the charging relay of the inverter is closed. Normal voltage may only be connected if the charging relay is open. Therefore, one of the two feedback contacts must be included in the making circuit.

Refer to proposed circuitry, page 6-7, 6-8.

Connections on supply module

Terminal strip X76 (only for DS..K xxx2, in set-up mode)

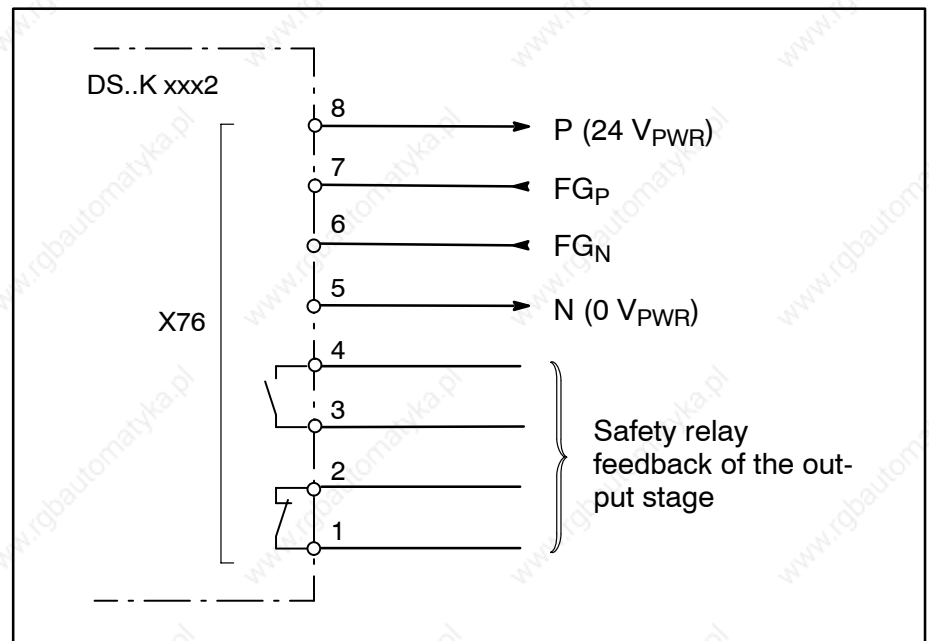

X76.1/2 Normally-closed contact Safety relay feedback (only for DS..K xxx2)

Ready contact (floating). Max. load 30 VDC/2000 mA.

The X76.1/2 relay contact is opened when the internal safety relay activates the output stage.

X76.3/4 Normally-open contact Safety relay feedback (only for DS..K xxx2)

Ready contact (floating). Max. load 30 VDC/2000 mA.

The X76.1/2 relay contact is closed when the internal safety relay activates the output stage.

X76.5 N 0 V_{PWR} (only for DS..K xxx2 only)

Same potential as X30.2.

To be bridged with pin 6 if Safe Shutdown of the output stage is not required.

X76.6/7 FG_N/FG_P Activating the power output stage (only for DS..K xxx2)

Energy supply to the power output stage is activated or deactivated by a 24 V signal. Use this input to isolate one energy supply channel. A motor contactor is no longer needed in this case. The safety relay is monitored by the positively driven contacts X76.1/2 and X76.3/4.

If this function is not needed, pin 6 and pin 7 have to be bridged with pin 5 and pin 8, respectively.

Connections on supply module

X76.8 P 24 V_{PWR} (only for DS..K xxx2)

Same potential as X30.1.

To be bridged with pin 7 if Safe Shutdown of the output stage is not required.

6.4 Start logically linked to EMERGENCY-STOP switchgear



DANGER

In case of a malfunction, the inverter should be disconnected from the supplying mains! For this purpose, switch the STA contact into the latching function of the K1 mains contactor.

Connections on supply module

Start logically linked for inverters with analog interface, Motion Control, CAN bus, PROFIBUS-DP

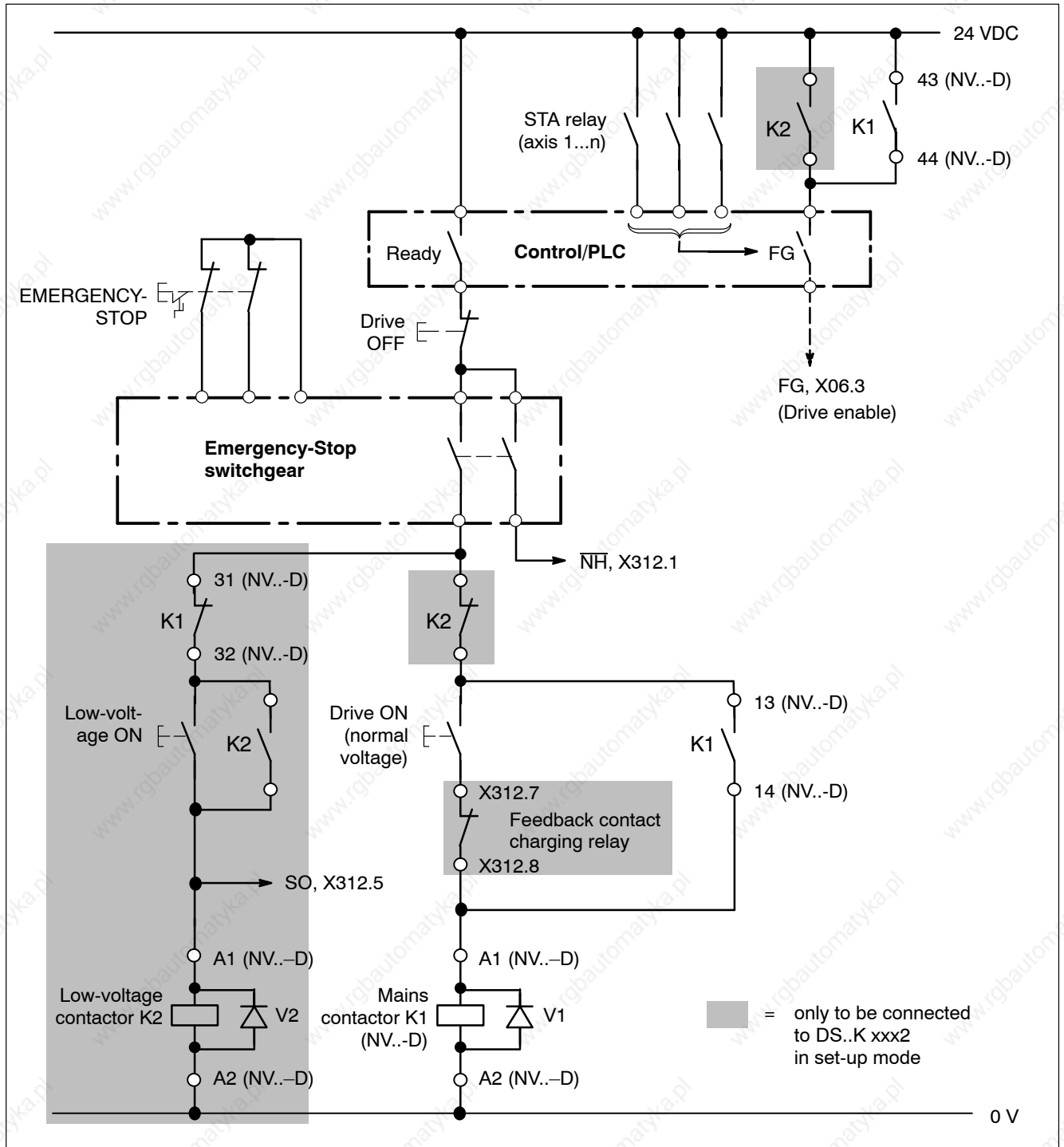

In case of EMERGENCY-STOP, inverters enabled with FG/FGI signal "VM switched off with active control (F98)". This message can be acknowledged by setting FG again.

Connections on supply module

Start logically linked for inverters with SERCOS interface



In case of EMERGENCY-STOP, inverters enabled with FG/FGI signal "VM switched off with active control (F98)". This message can be acknowledged with "Reset diagnostics class 1".

DS control connections (analog/MC)

7 DS control connections

7.1 Connection of analog interface or positioning function (MC)

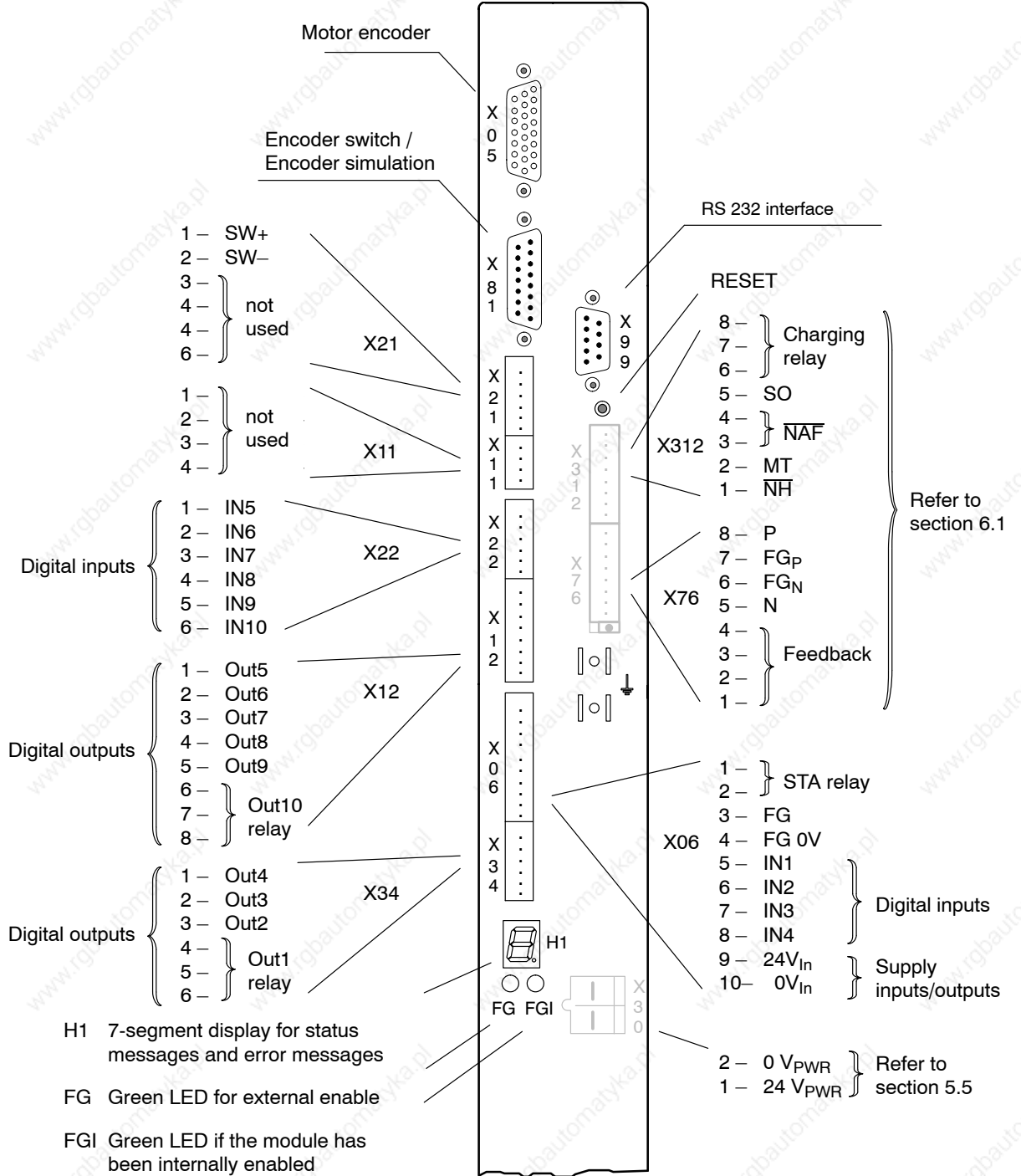

DS control connections (analog/MC)

7.1.1 Inputs

Terminal strip X06

Inverter with analog interface/Motion Control

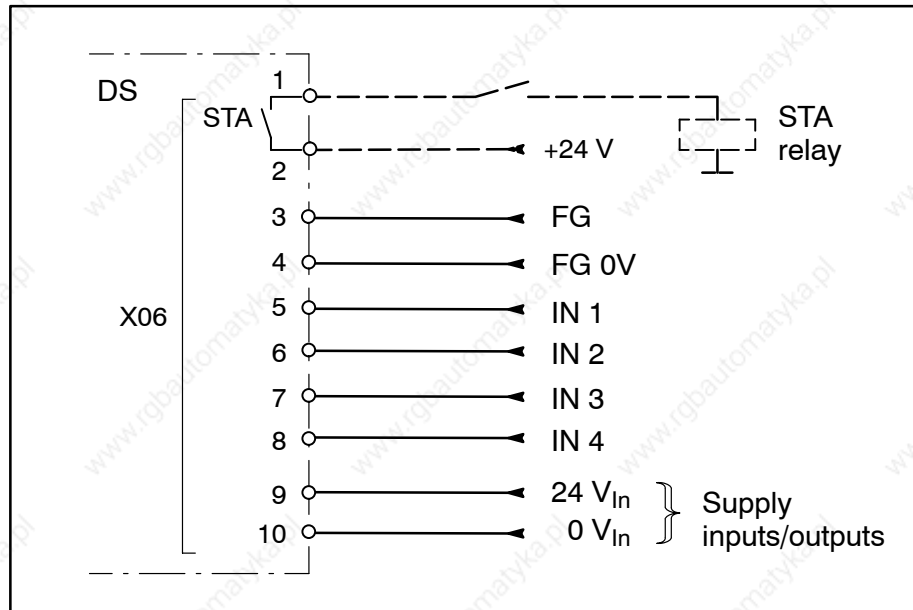

X06.1/2 STA Status message

Floating relay contact. Max. load 24 V / 1000 mA.

The contact closes if the following conditions have been fulfilled:

- 24 V supply is available
- No errors in the DS (hardware)

In case of a malfunction, the STA contact is immediately opened and the output stage is blocked. The STA contact can be evaluated as a group error message.

X6.4/3 FG External enable Display via LED "FG"

Optocoupler input. Active with +24 V, 10 mA (15...30 V, 5...14 mA).

If a high level exists at X6.3 with regard to X6.4 the controller and axis are enabled via the internal enable FGI if:

- no errors are active in the DS (LED display "FGI").

☞ **If the mains voltage is switched off while the enable signal is present, the drive signals error F97.**

DS control connections (analog/MC)

X06.5/6/7 IN 1, IN 2, IN 3 24 V inputs

Optocoupler inputs.

Active with +24 V DC (15...30 V) with regard to X6.10.

Input current typically 17 mA.

Assignment	Functionality	
	Servo function	Positioning function
Default setting: X06.5 (IN 1)	—	Block select: Coded position number 2^0 (bit 1)
X06.6 (IN 2)	Start signal for output of the absolute encoder position using X81. Cf. page 8–7.	Block select: Coded position number 2^1 (bit 2)
X06.7 (IN 3)	—	Block select: Coded position number 2^2 (bit 3)

X06.8 IN 4 24 V input

Optocoupler input.

Active with +24VDC (15...30V) with respect to X6.9.

Input current typically 13 mA.

IN4 is a high-speed input that may be used:

- as normal input
- for synchronizing the module to the external signal that can be applied to this input.

Assignment	Functionality	
	Servo function	Positioning function
Default setting: X06.8 (IN 4)	High-speed input	Block select: Coded position number 2^3 (bit 4)

X06.10/9 24 V_{In}, 0 V_{In} Supply of the outputs

Supply voltage of the outputs at X34, to be connected to the 24 V supply voltage.

DS control connections (analog/MC)

Terminal strip X21



X21.1/2 SW+/SW- Setpoint input

Input voltage range $\pm 10V$, input resistance $\geq 20\text{ k}\Omega$.

Assignment	Functionality	
	Servo function	Positioning function
X21.1, 2 (SW+,-)	Analog setpoint: <ul style="list-style-type: none"> • 12-bit resolution for DS.....33xx - D • 16-bit resolution for DS.....4xxx - D 	not used (setpoints are stored in the positioning table)

- Always connect both poles of the setpoint cable, differential input.
- The direction of rotation is determined by the polarity.
- If intermediate terminals or connectors are used for wiring, the shield continuity must not be interrupted. Connect the shield conductor to \perp at the point of separation.

DS control connections (analog/MC)

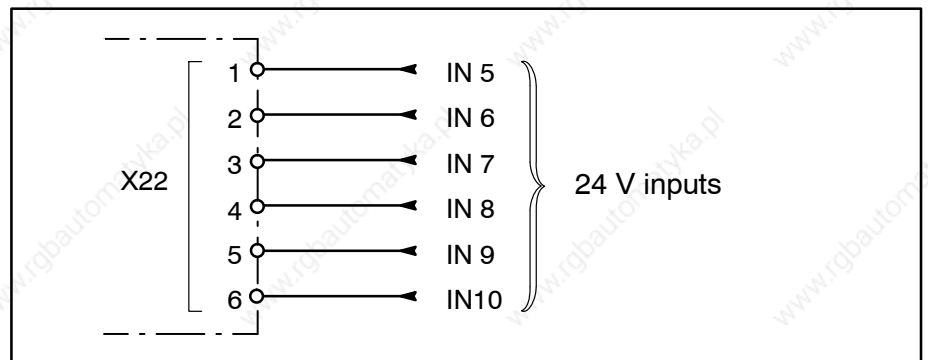
Terminal strip X22**X22.1–6 IN 5 – IN 10 24 V inputs**

Optocoupler inputs.

Active with +24 VDC (15...30V) with respect to X6.10.

Input current typically 13 mA.

Assignment	Functionality	
	Servo function	Positioning function
Default setting: X22.1 (IN 5)	—	Block select: Coded position number 2 ⁴ (bit 5)
X22.2 (IN 6)	—	Start and stop movement
X22.3 (IN 7)	—	Mode selection: 2 ⁰ (bit 1), cf. page 8–10
X22.4 (IN 8)	—	Mode selection: 2 ¹ (bit 2), cf. page 8–10
X22.5 (IN 9)	—	Reference cam
X22.6 (IN 10)	—	Home position (cancels the traversing movement, clears the dis- tance to go and sets the output signal X12.3, position reached)

DS control connections (analog/MC)

7.1.2 Outputs

Terminal strip X12

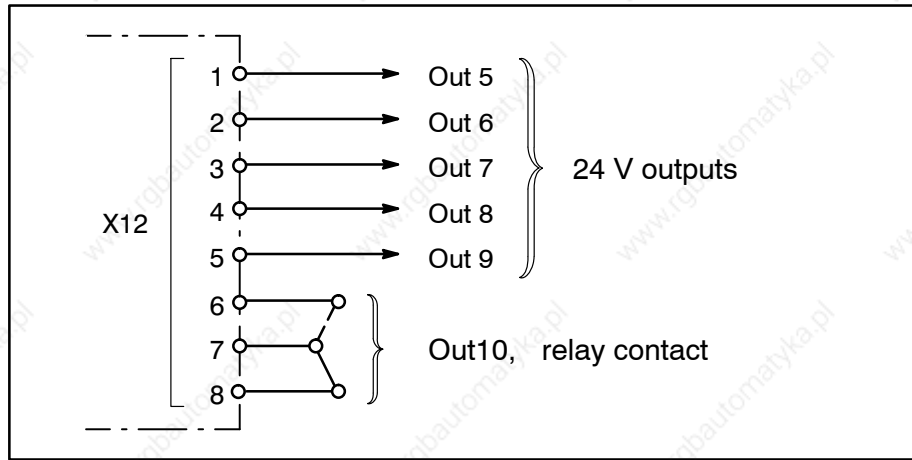

X12.1-5 Out 5 – Out 9 24 V outputs

Driver outputs, max. load 24V/0.5 A.

Assignment	Functionality	
	Servo function	Positioning function
X12.1 (Out 5)	Standstill monitoring $n = 0$	Axis has been referenced
X12.2 (Out 6)	Speed monitoring $n = n_{set}$	Axis active
X12.3 (Out 7)	–	In position
X12.4 (Out 8)	–	End of program/block
X12.5 (Out 9)	–	Home position reached (new inputs are now possible)

X12.6/7/8 Out10 Programmable relay contact

Floating relay contact, can be connected as a normally-closed contact or a normally-open contact. Max. load 24 V/1000 mA.

Assignment	Functionality	
	Servo function	Positioning function
X12.6-8 (Out 10)	–	MC status message

For more information on the MC functions, please refer to the Application instructions on page 8-10.

DS control connections (SERCOS interface)

7.2 Connection with SERCOS interface

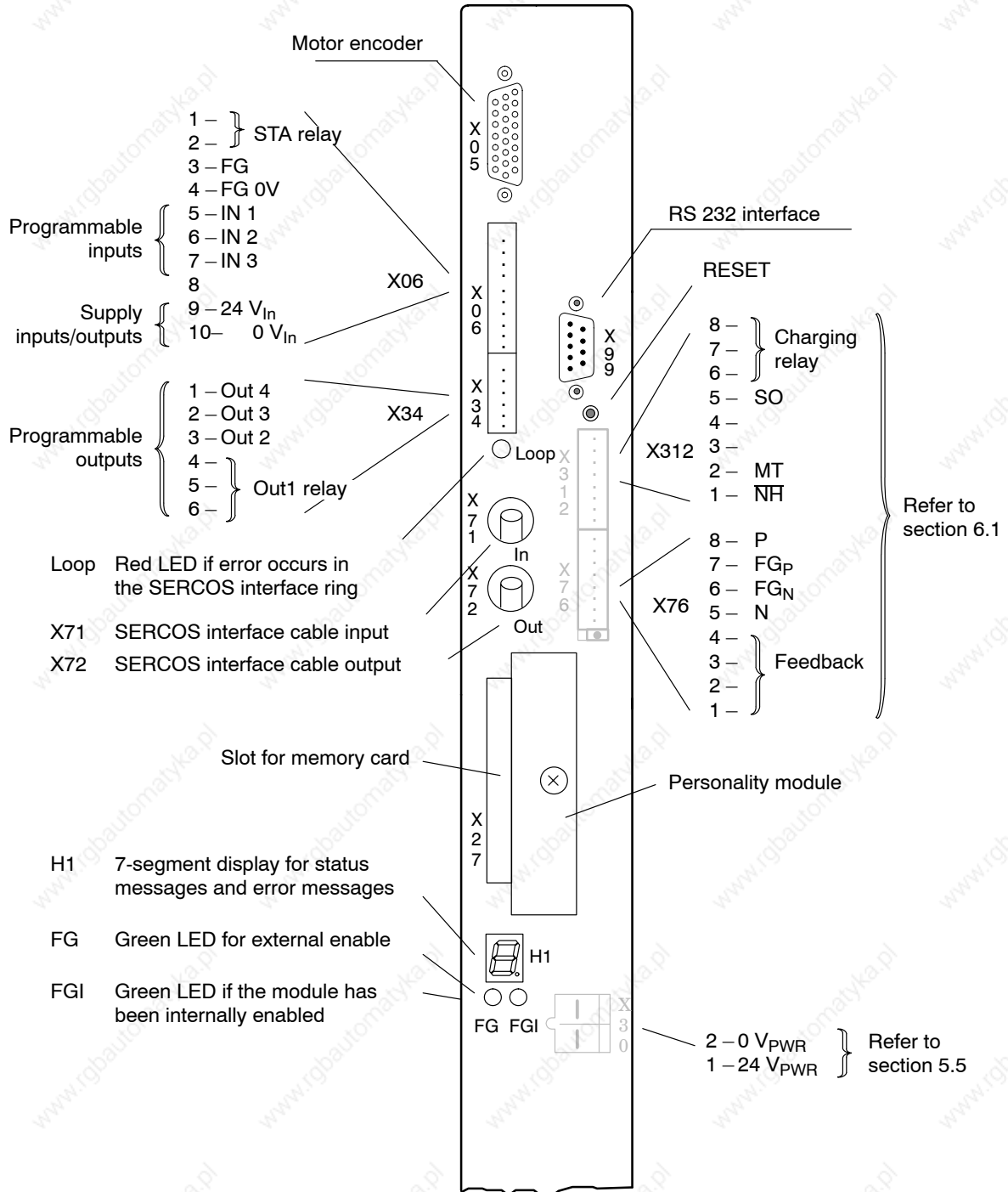

DS control connections (SERCOS interface)

Terminal strip X06

(Inverter with SERCOS interface)

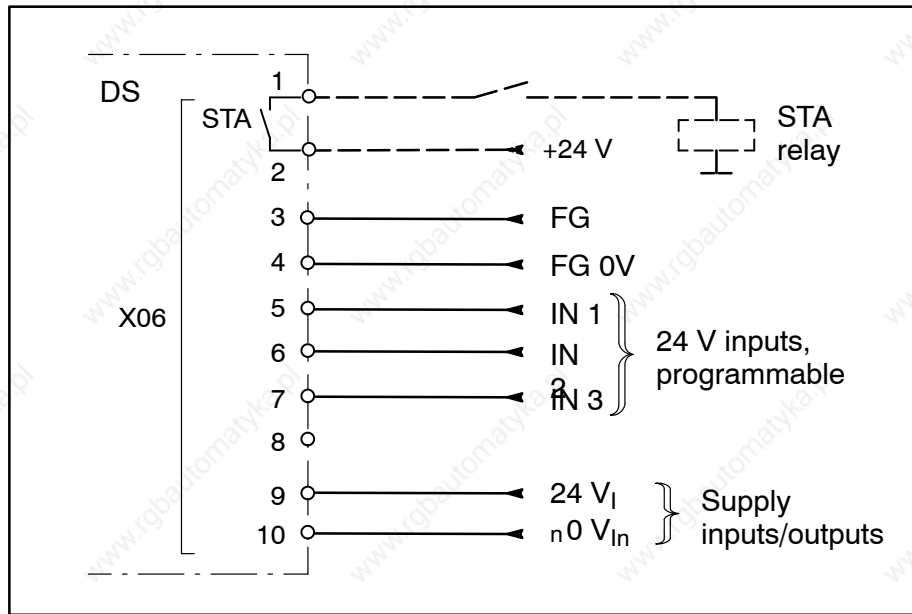

X06.1/2 STA Status message

Floating relay contact. Max. load 24 VDC / 1000 mA. The contact signals its readiness for interface operation. It closes if the following conditions have been fulfilled:

- 24 V supply is available
- No errors in the DS

In case of a malfunction, the STA contact is immediately opened and the output stage is blocked. The STA contact can be evaluated as a group error message.

X6.4/3 FG External enable Display via LED "FG"

Optocoupler input. Active with +24 VDC (16...30 V).

If a high level exists at X6.3 with regard to X6.4 the controller and axis are enabled via the internal enable signal FGI (display via LED "FGI"). The following conditions must first of all be fulfilled:

- Central enable has been given.
- Software enable available via the SERCOS interface ("Drive enable" and "Drive on").



DANGER
 When the external enable signal FG is deactivated the motor always comes to a stop without setpoint control!
 Activate plug braking or an integrated holding brake in this case.
 You should always use the software enable functions "Drive enable" and "Drive on" (cf. Section 8.1) to switch the drives.

DS control connections (SERCOS interface)

 **If the mains voltage is switched off while the enable signal is present, the drive signals error F97.**

X06.5/6/7 IN 1, IN 2, IN 3 Programmable 24 V inputs

Optocoupler inputs.

Active with +24 V DC (16...30 V) with regard to X6.10.

Input current typically 17 mA.

Assignment:

- **X6.5:** Reference point switch
- **X6.6:** Limit switch, positive traverse direction
- **X6.7:** Limit switch, negative traverse direction

X06.9/10 24 V_{In}, 0 V_{In} Supply of the outputs

Supply voltage of the outputs at X34, to be connected to the 24 V supply voltage.

SERCOS interface connection (X71/72)

The complete data exchange between the drives and the higher-level control takes place via the SERCOS interface.

An optical fibre in accordance with the SERCOS interface specifications must also be connected.



The connectors used comply with the F-SMA standard in accordance with IEC 874-2.

The optical fibre is made of plastic and has a step index profile. Optical fibre cores and cables can be used.



DANGER

Do not look directly into the LEDs in the optical fiber connection. Due to their high output, this may result in eye injuries.

When the inverter is switched on, do not look into the LED or the open end of a short connected lead.

DS control connections (CAN bus)

7.3 Connection with CAN bus

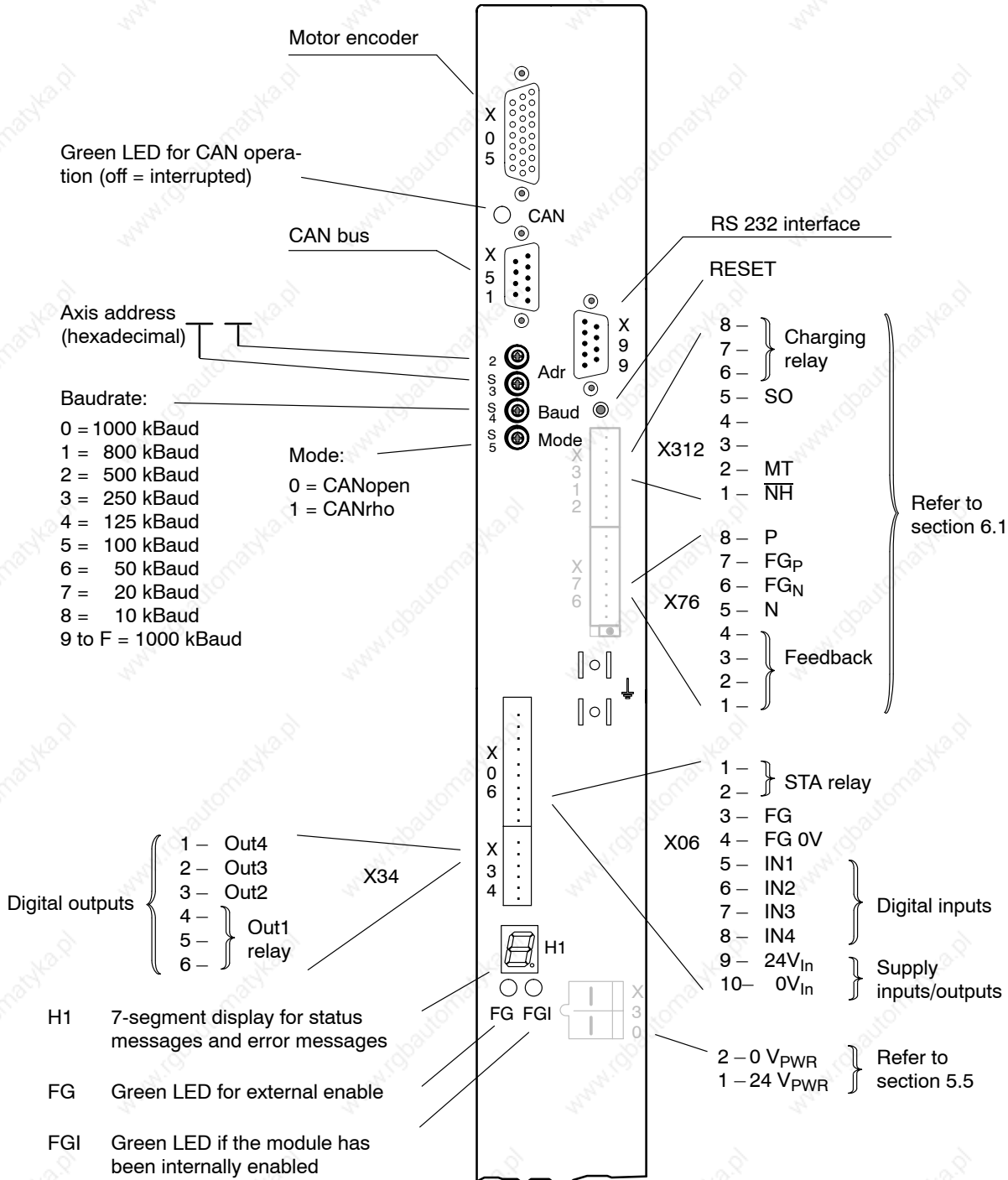

DS control connections (CAN bus)

Terminal strip X06**(Inverter with CAN bus)****X06.1/2 STA Status message**

Floating relay contact. Max. load 24 VDC / 1000 mA.

The contact closes if the following conditions are met:

- 24 V supply is available
- No errors in the DS

In case of a malfunction, the STA contact is immediately opened and the output stage is blocked. The STA contact can be evaluated as a group error message.

**X6.4/3 FG External enable
Display via LED "FG"**

Optocoupler input. Active with +24 VDC, 10 mA (15...30 V, 5...14 mA).

If a high level exists at X6.3 with regard to X6.4 the controller and axis are enabled via the internal enable signal FGI if:

- no errors are active in the DS (LED display "FGI").

DS control connections (CAN bus)

X06.5/6/7 IN 1, IN 2, IN 3 24 V inputs

Optocoupler inputs.

Active with +24 VDC (15...30 V) with regard to X6.10.

Input current typically 17 mA.

Assignment

Default setting:

X06.5
(IN 1)

-

X06.6
(IN 2)

-

X06.7
(IN 3)

-

X06.8 IN 4 24 V input

Optocoupler input.

Active with +24VDC (15...30V) with respect to X6.10.

Input current typically 13 mA.

IN4 is a high-speed input that may be used:

- as normal input
- for synchronizing the module to the external signal that can be applied to this input.

Assignment

Default setting:

X06.8
(IN 4)

High-speed input

X06.10/9 24 V_{In}, 0 V_{In} Supply of the outputs

Supply voltage of the outputs at X34, to be connected to the 24 V supply voltage.

DS control connections (CAN bus)

CAN bus connection (X51)



CAN cable

Both physical ends of the CAN cable must be equipped with a terminating resistor with typ. 120 Ω. The ready-made CAN cables from Bosch are therefore different on the drive side:

- Through-way plug, black (T adapter between the cable ends) and
- Terminating plug, green (T adapter with terminating resistor)

The admissible length of the cable connecting the control unit and the drives depends on the baudrate setting, part no. on request:

Baudrate	Total cable length
1000 kbits/s	25 m
800 kbits/s	50 m
500 ... 10 kbits/s	100 m

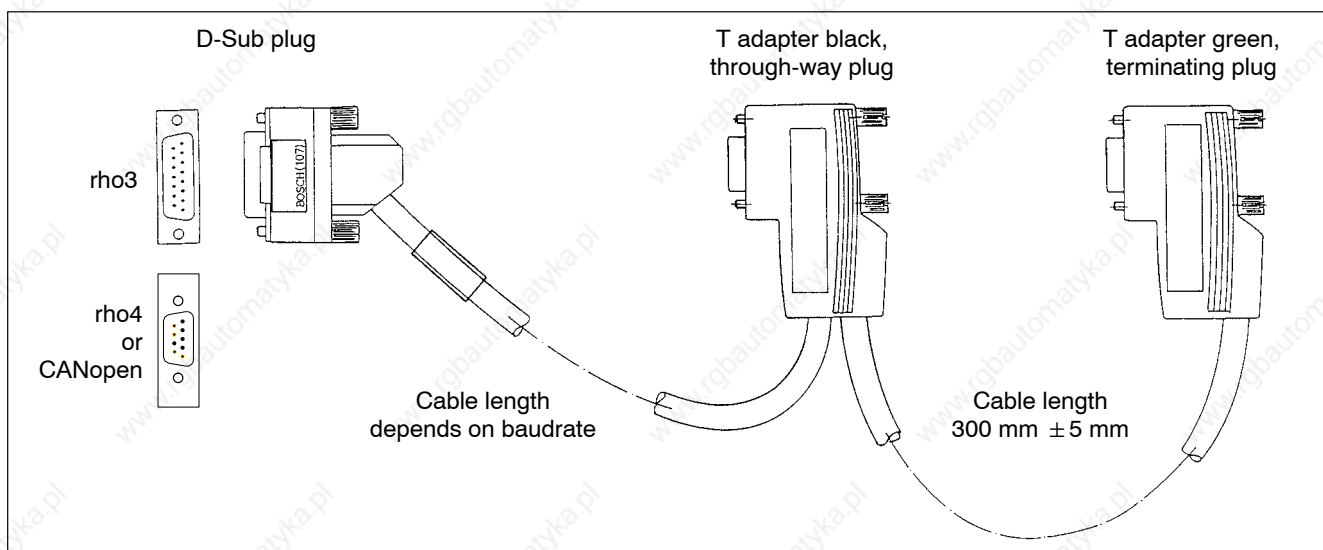

DS control connections (CAN bus)

For self-made CAN cables, the following connector assignment must be observed. The 15-pin female connector of rho3 covers 2 bus systems:

CAN cable for rho3 control (1 bus system occupied)

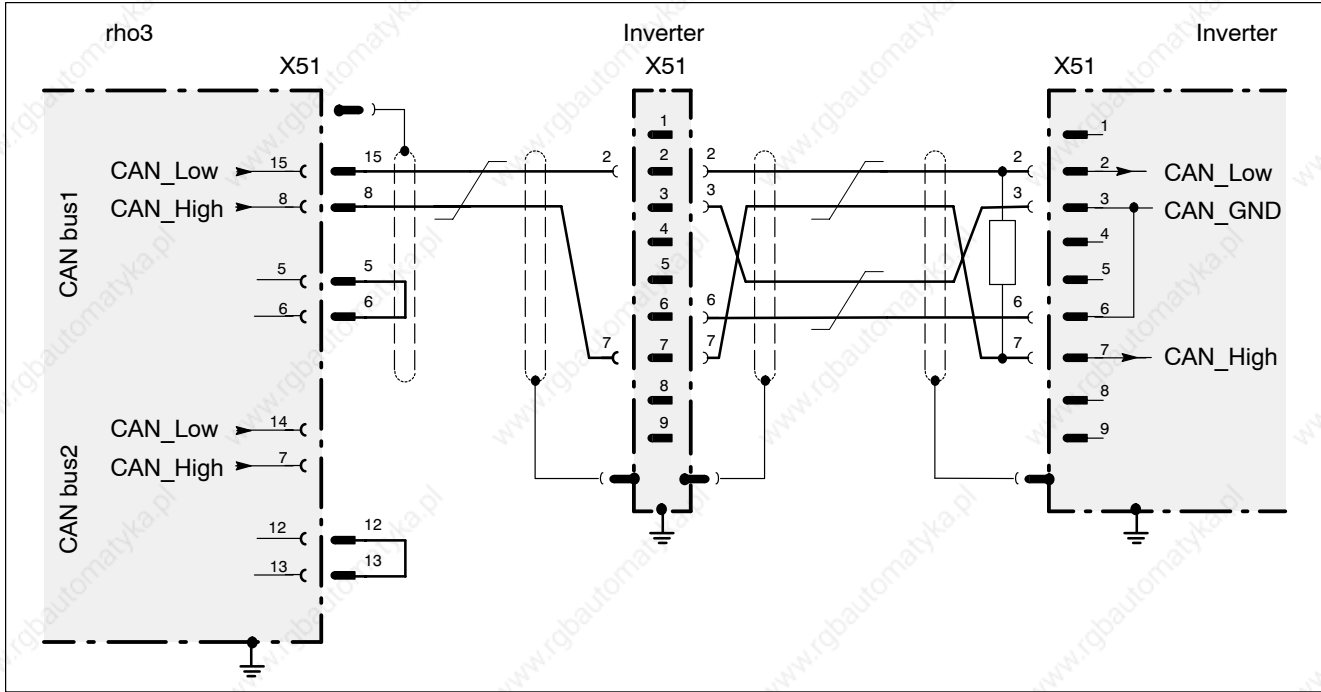

CAN cable for rho4 control or any other control unit with CANopen

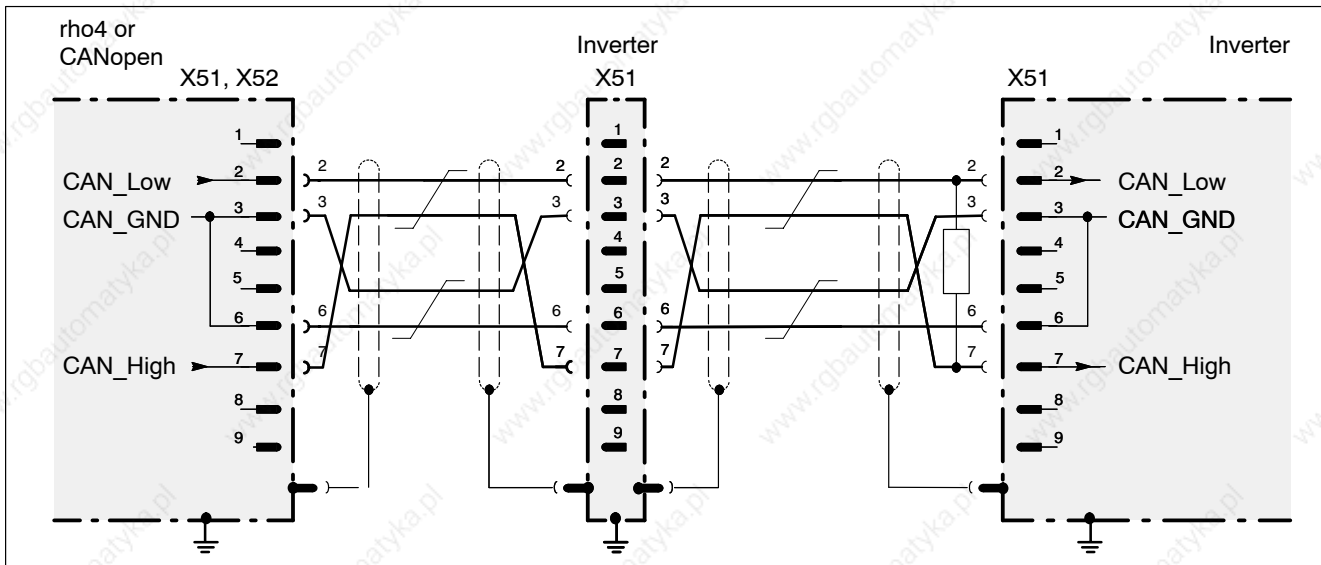

DS control connections (CAN bus)

Rexroth CAN connectors have been prepared for use with jumpers or terminating resistors, so that the cables can be connected as shown below.

CAN connectors at the drives

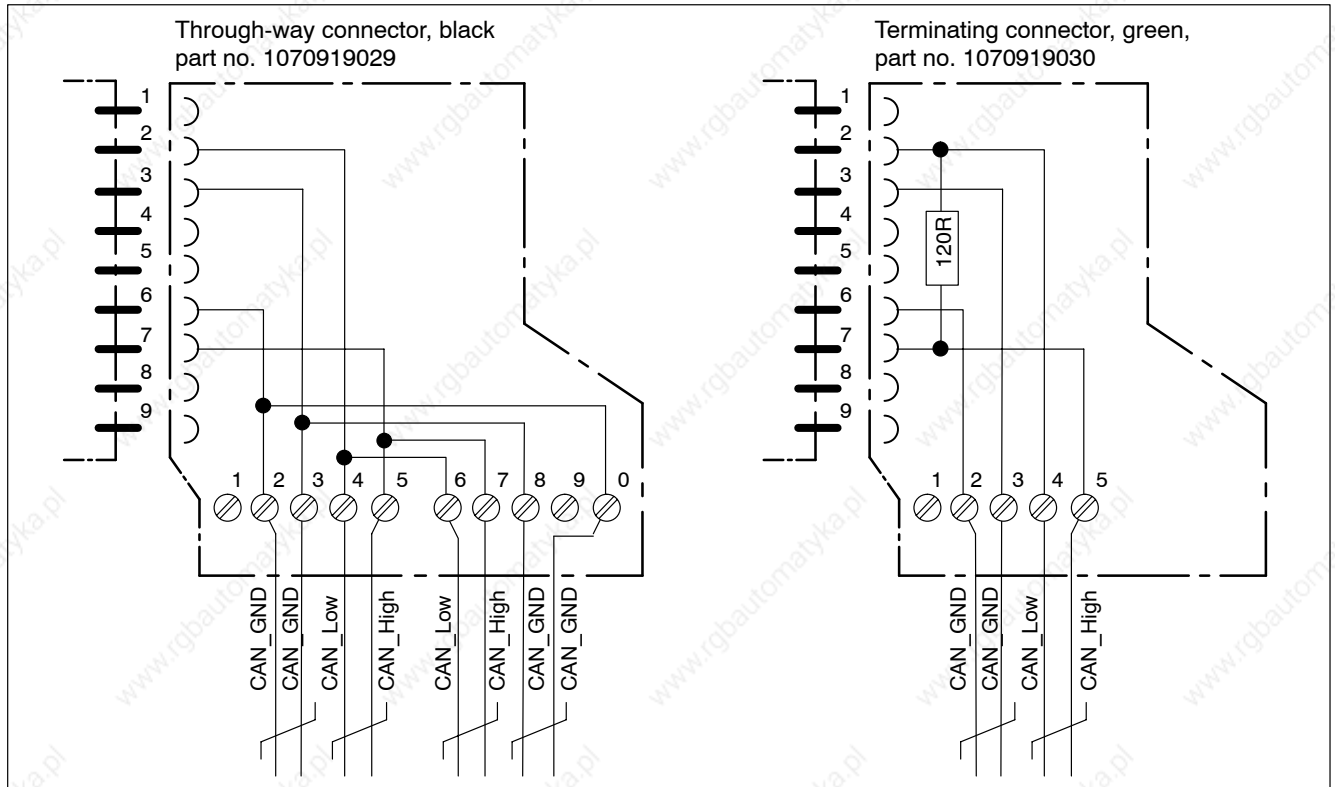

Rotary switches S2...S5

ServoDyn D with CAN bus can be operated with the CANrho protocol or the CANopen protocol. All CAN-specific settings are adjusted with rotary switches S2...S5 on the front panel:

Axis address	Hexadecimal switch position										
	0	1	2	3	4	5	6	7	8	9...F	
S2	LOW axis address (random)										
S3	HIGH axis address (random)										
Baudrate [kbits/s]											
S4	1000	800	500	250	125	100	50	20	10	1000	
Mode											
S5	CANopen	CANrho	not used							F = test	

CAN display

Green LED	Meaning
off	CAN bus is interrupted
flashing	Only receiving the synchronization telegram
on	CAN bus works

DS control connections (PROFIBUS-DP)

7.4 Connection with PROFIBUS-DP

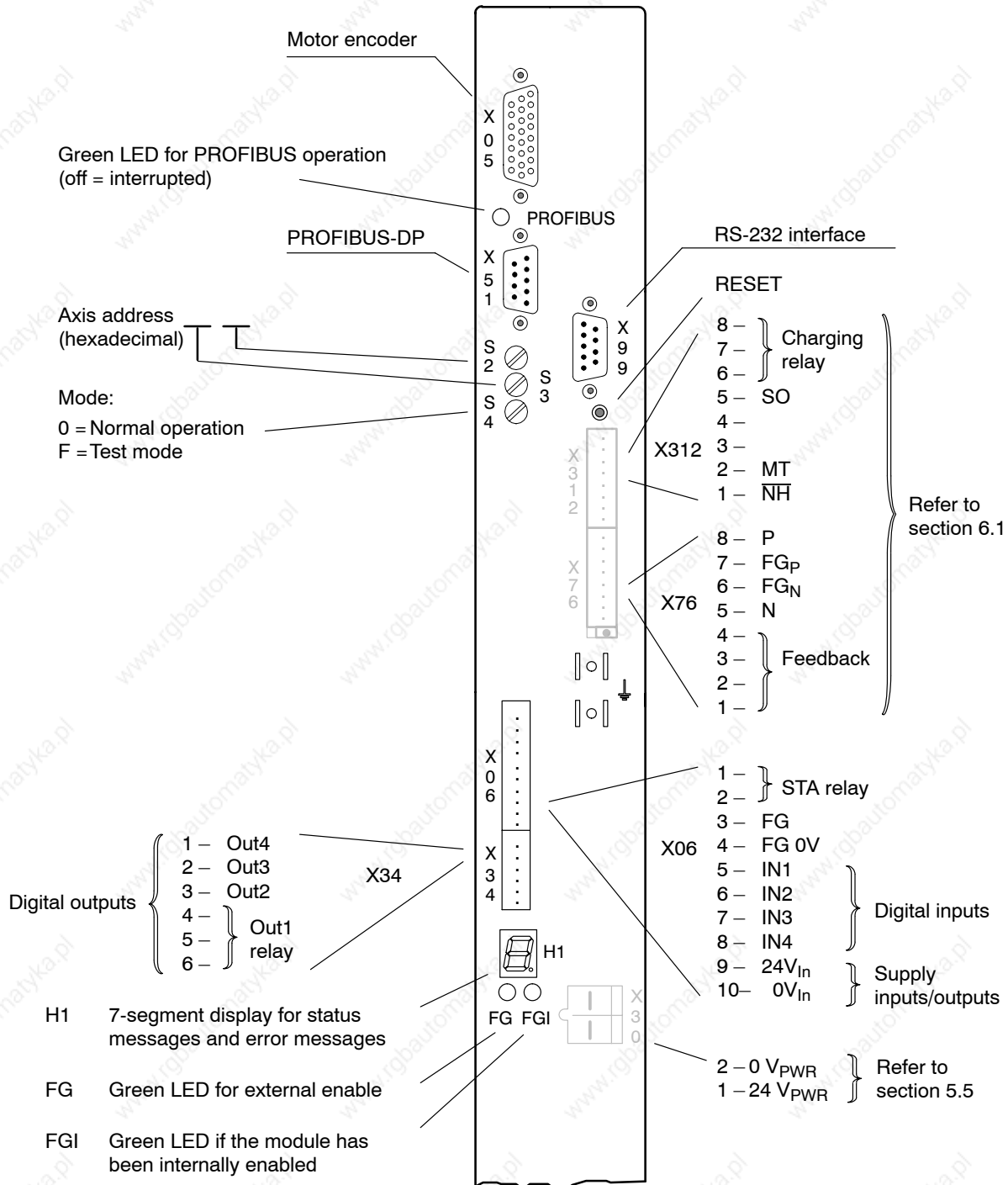

DS control connections (PROFIBUS-DP)

Terminal strip X06**(Inverter with PROFIBUS-DP)****X06.1/2 STA Status message**

Floating relay contact. Max. load 24 VDC / 1000 mA.
The contact closes if the following conditions are met:

- 24 V supply is available

In case of a malfunction, the STA contact is immediately opened and the output stage is blocked. The STA contact can be evaluated as a group error message.

**X6.4/3 FG External enable
Display via LED "FG"**

Optocoupler input. Active with +24 VDC, 10 mA (15...30 V, 5...14 mA).

If a high level exists at X6.3 with regard to X6.4 the controller and axis are enabled via the internal enable signal FGI if:

- no errors are active in the DS (LED display "FGI").

DS control connections (PROFIBUS-DP)

X06.5/6/7 IN 1, IN 2, IN 3 24 V inputs

Optocoupler inputs.

Active with +24 VDC (15...30 V) with regard to X6.10.

Input current typically 17 mA.

Assignment

Default setting:

X06.5
(IN 1)

-

X06.6
(IN 2)

-

X06.7
(IN 3)

-

X06.8 IN 4 24 V input

Optocoupler input.

Active with +24VDC (15...30V) with respect to X6.10.

Input current typically 13 mA.

IN4 is a high-speed input that may be used:

- as normal input
- for synchronizing the module to the external signal that can be applied to this input.

Assignment

Default setting:

X06.8
(IN 4)

High-speed input

X06.10/9 24 V_{In}, 0 V_{In} Supply of the outputs

Supply voltage of the outputs at X34, to be connected to the 24 V supply voltage.

DS control connections (PROFIBUS-DP)

PROFIBUS-DP connection (X51)

D-Sub connector, 9-pin

Type: RS-485; field bus connection to EN 50170 Part 2 (DP)

Cable length: depending on transmission rate used, max. 100 m at 12 Mbits/s

Cable type: screened, min. core cross-section 0.14 mm²

Transmission rate: automatic detection, max. 12 Mbits/s



Rotary switches S2...S4

Axis address	Hexadecimal switch position		
	0	1...E	F
S2	LOW axis address (random)		
S3	HIGH axis address (random)		
Mode			
S4	Normal operation	not used	Test

PROFIBUS-DP display

Green LED	Meaning
off	PROFIBUS-DP is interrupted
on	PROFIBUS-DP bus works

DS..8001 (ASM) control connections

7.5 Connections on the DS..8001 frequency inverter



In order to change parameters after the inverter has been booted (7-segment display = "H"), press the boot key in the housing recess (7-segment display = "H"), press the boot key in the housing recess below the two LEDs with a pointed object. For this purpose, carefully press down the signal cross-link X810, which covers up the button.

DS..8001 (ASM) control connections

Terminal strip X06**(Frequency inverter)****X06.1/2 STA Status message**

Floating relay contact. Max. load 24 VDC / 1000 mA.
Display via 7-segment display.

The contact closes if the following conditions have been fulfilled:

- 24 V supply is available
- No errors in the DS

In case of a malfunction, the STA contact is immediately opened and the output stage is blocked. The STA contact can be evaluated as a group error message.

X6.4/3 FG External enable

Optocoupler input. Active with +24 VDC, 10 mA (15...30 V, 5...14 mA).
Display via LED.

If a high level exists at X6.3 with regard to X6.4 the controller and axis are enabled via the internal enable FGI if :

- no errors are active in the DS (LED display "FGI").

The behavior of the internal enable signal FGI when FG has been switched off can be selected with P19, P20:

- FGI is switched off immediately, the motor is halted without setpoint control, or

DS..8001 (ASM) control connections

- FGI is switched off with a delay when $f = 0$ or $n = 0$ (with active standstill monitoring) has been reached.

**CAUTION**

A contactor in the motor lead must not be opened before the internal enable signal FGI has been switched off. Please use the FGI contact for triggering this function (cf. page 7-27)

X6.5/6/7 PLA, PLB, PLC Select parameter list

Optocoupler input. Active with +24 VDC.

The parameter list selected with this function is active for motor operation and can be programmed via the keyboard.

Terminal strip			Active parameter list
X6.5 (PLA)	X6.6 (PLB)	X6.7 (PLC)	
–	–	–	PL 1
1	–	–	PL 2
–	1	–	PL 3
1	1	–	PL4
–	–	1	PL5
1	–	1	PL 6
–	1	1	PL 7
1	1	1	PL8

1 = HIGH level, – = LOW level

X06.8 DCB Direct current brake

Optocoupler input. Active with +24 VDC.

For as long as 24 V are active, the motor is braked with a direct current in accordance with parameter P22 if:

- Parameter P21 is set to 'dc1' or 'dc2'
- External enable FG available
- Output frequency < start frequency P24



For more features of direct current braking, please refer to manual 'Frequency inverters DM/DS..8001 (ASM)', part number on page 1-7.

X06.10/9 24 V_{in}, 0 V_{in} Supply of the outputs

Supply voltage of the outputs at X34, to be connected to the 24 V supply voltage.

DS..8001 (ASM) control connections

Terminal strip X13**X13.1/2 TEMP Temperature warning**

Floating relay contact, normally-open contact.
Max. load 24 VDC/1000 mA. Display via 7-segment display.

The temperature warning refers to:

- The heat sink temperature of the inverter
- The motor temperature, if motor temperature sensors are connected, or the bimetal function (P43) is active.

The contact closes when the warning temperature is exceeded.

X13.3 I_{GR} Limit current, stability warning

Driver output, short-circuit-proof. Max. load 24 V /0.5 A

- **Limit current**

The output changes to LOW level if the limit current I_{\max} is exceeded. At the same time, the acceleration ramp is reduced, and there is danger that the motor may become electrically instable.

- **P33 active: Stability warning**

The output changes to LOW level, if the warning limit specific of the motor is exceeded.

Also refer to 'Frequency inverters DM/DS..8001 (ASM)' manual, part number on page 1-7.

X13.4 I_{RED} Current reduction

Optocoupler input. Active with +24 VDC.

The signal I_{red} reduces the maximum current of the module. The amount of limitation can be selected in parameter P18.

DS..8001 (ASM) control connections

Terminal strip X23

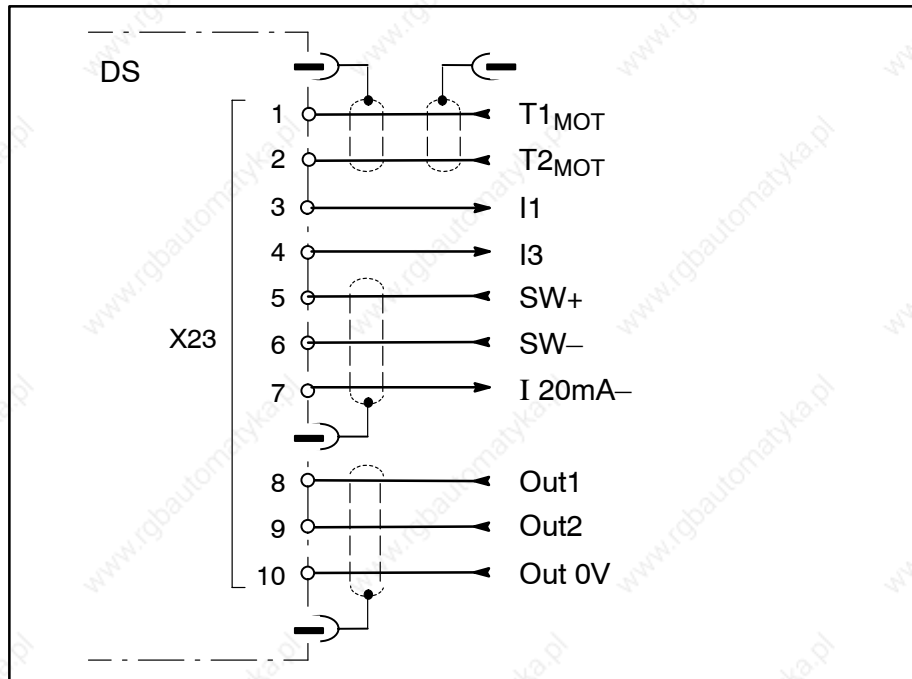

X23.1/2 T1_{MOT}, T2_{MOT} Motor temperature sensors

Input without electrical isolation, referred to 24 V potential.

- 5V supply voltage
- operating resistance ≥ 1.6 kΩ
- resetting resistance ≤ 1.0 kΩ



DANGEROUS ELECTRICAL VOLTAGE

You should use input X23.1/2 only if the motor temperature sensors meet the requirements on "Safety separation" to EN 50178.

PTC sensors or thermostatic switches may be used as temperature sensors.



CAUTION

Malfunctions and destroyed inputs through unshielded connection leads!

Only use shielded cables and connect shield at both ends.

DS..8001 (ASM) control connections

X23.3/4 I1, I3 Measuring outputs for actual current values

Short-circuit-proof analog outputs 0...+10 V, only for measuring purposes.

Output resistance: approx. 1 k Ω .

I1: Actual current value, phase 1
10 V \triangleq peak current

I3: Actual current value, phase 3
10 V \triangleq peak current

X23.5/6/7 SW+, SW–, I 20mA– Setpoint input

Analog input, 10-bit resolution.

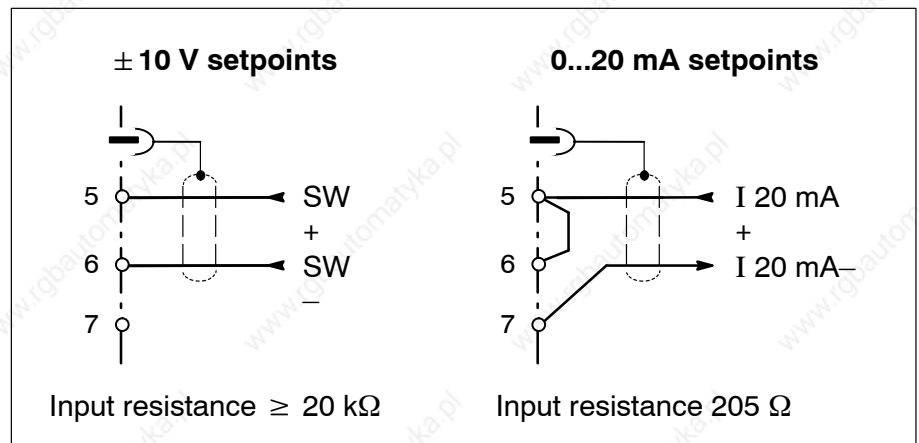

It is only possible to use either the voltage or the current setpoint input. If the voltage input is used, X23.7 must not be connected.

- Always connect both poles of the setpoint cable, differential input.
- The voltage/current setpoints for maximum setpoints can be adjusted (parameters P15, P16).
Unipolar setpoints are equally possible.
e.g. 0...+10 V with $f = f_{\text{max}}$ adjustment to +10 V
 $f = 0$ adjustment to +5 V
- In the event of a bipolar setpoint, the motor's direction of rotation is determined by the polarity.
A positive setpoint means clockwise rotation if motor cables are properly connected and when looking at the drive side of the shaft.
- If intermediate terminals or connectors are used for wiring, the shield continuity must not be interrupted. Connect the shield conductor to \perp at the point of separation.

DS..8001 (ASM) control connections

X23.8/9/10 Out1, Out2, Out 0V Analog outputs, programmable

Short-circuit-proof analog outputs 0...+10 V.
8-bit resolution, output resistance approx. 1 k Ω .

Programming/Default setting:

Output (reference potential X23.10)	Assignment	
	via parameters	Setting ex works
X23.8 (Out1)	P40	AA1 (total current)
X23.9 (Out2)	P39	AA0 (actual output frequency)

Both outputs can be assigned the data AA0 ... AA9 listed in the following table.

Level 0... +10 V, current and power signals can be adjusted (P41, P42).

Assignment		10 V Δ ... () = Setting ex works	
		DS..15K	DS..45K
Actual output frequency (AA0)	[Hz]	max. output frequency (P02)	
Total current, rms (AA1)	[A]	Scaling with P41:	
Active current, rms (AA2)	[A]	1.5...25 (15.9)	4.7...75 (47.7)
Reactive current, rms (AA3)	[A]		
Motor voltage (AA4)	[V]	1000 V	
DC link voltage (AA5)	[V]		
Total output (AA6)	[kVA]	Scaling with P42:	
Shaft output (AA7)	[kW]	0.7...12.5 (12.5)	2.3...37.5 (37.5)
Utilization rate (AA8)	[%]	200 %	
Heat sink temperature (AA9)	[°C]	100 °C	

 **The following applies in general to the programming of the frequency inverter via the DSS-D:**
Press Boot key prior to any parameter change (refer to page 7-20).
All values displayed at the drive in alpha-numerical format are stored as purely numerical values in the DSS-D. When making entries, you should therefore omit the letters, e.g. enter "7" in the DSS instead of "AA7" for the shaft output.

DS..8001 (ASM) control connections

Terminal strip X34**(Frequency inverter)****X34.1 $f_i < f_x$ Frequency warning (reference frequency)**

Driver output, short-circuit-proof. Max. load 24 V/0.5 A.

The signal changes to LOW level if the actual output frequency falls below a reference frequency set with P38. The STA contact remains closed.

X34.2 $f_i = f_s$ Frequency warning (set frequency)

Driver output, short-circuit-proof. Max. load 24 V/0.5 A.

The signal changes to LOW level if the actual output frequency equals the set frequency.

X34.3 $n = 0$ Standstill monitoring

Driver output, short-circuit-proof. Max. load 24 V/0.5 A.

The signal changes to HIGH level if the motor has reached $n = 0 \text{ min}^{-1}$ and stands for approx. 1.5 sec. when external enable FG has been removed.

X34.4/5/6 FGI Internal enable

Floating relay contact, can be connected as n.c.c. or n.o.c. Max. load 24 VDC / 1000mA. Display via LED.

The contact operates (pin 5/6 open) for as long as internal enable is present (cf. page 7-21).

DS control connections

7.6 Standard connection of X34 (analog interface, SERCOS interface, CAN bus, PROFIBUS-DP)

Terminal strip X34

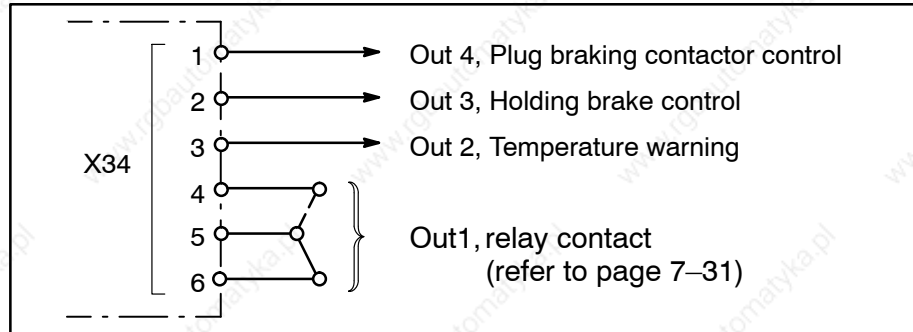

X34.1 Out 4 Plug braking contactor control

Driver output, short-circuit-proof. Max. load 24 V / 0.3 A.

This signal is used to control the plug braking contactor K03, 0 V connection of the plug braking contactor at X332 of the VM.

Plug braking serves to brake synchronous motors as fast as possible if the motors cannot be actively braked because of a power voltage or control failure.

Motor braking is effected by suitable plug braking modules which short-circuit the motor winding, cf. Servo motors SF, SR manual.

The normally-closed contact of the KSB (plug braking) contactor must be designed as a make contact.

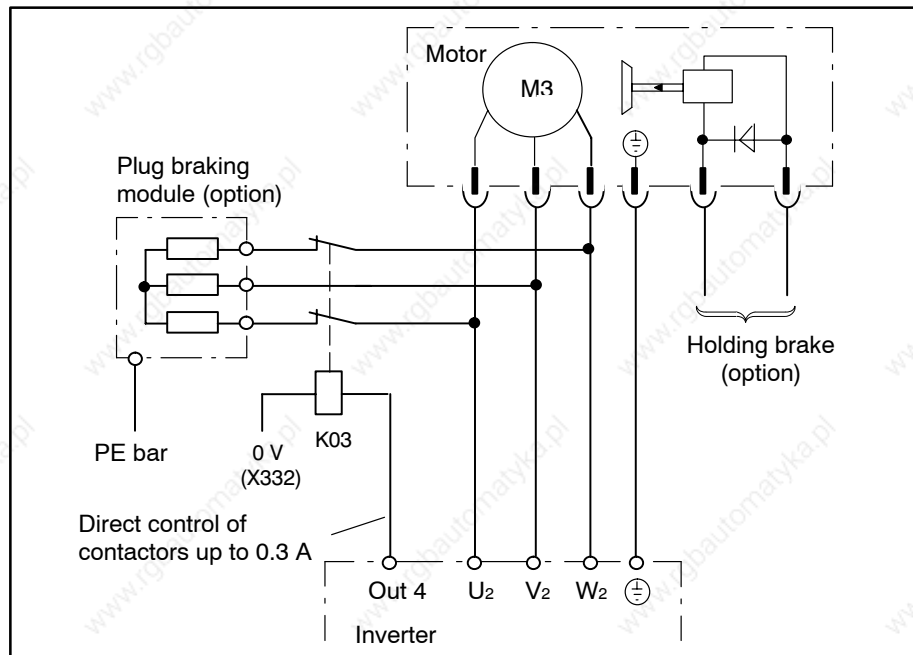

 **In the case of contactors with a power input > 0.3 A an amplifier, e.g. a relay, must be inserted to control the contactor.**

DS control connections

X34.2 Out 3 Holding brake control

Driver output, short-circuit-proof. Max. load 24 V / 0.3 A.

In the case of holding brakes, control of the FG enable signal, the set-point and the holding brake must be synchronized. The holding brake may only be activated when the axes have come to a standstill. Exception: Emergency braking operations e.g. when the supply module breaks down.

The required chronological order has already been established by means of the holding brake control signal. The motor's holding brake is controlled by means of a contactor which must be set up externally, braking contactor 0 V connection at X332 on the VM supply module.



CAUTION

The holding brake must not be operated unless the axis has come to a stop!

If the holding brake is not controlled via module output Out 3, proper timing as described in the Servo motors SF, SR manual must be ensured.

DS control connections



 **In the case of contactors with a power input > 0.3 A an amplifier, e.g. a relay, must be inserted to control the contactor.**

DS control connections

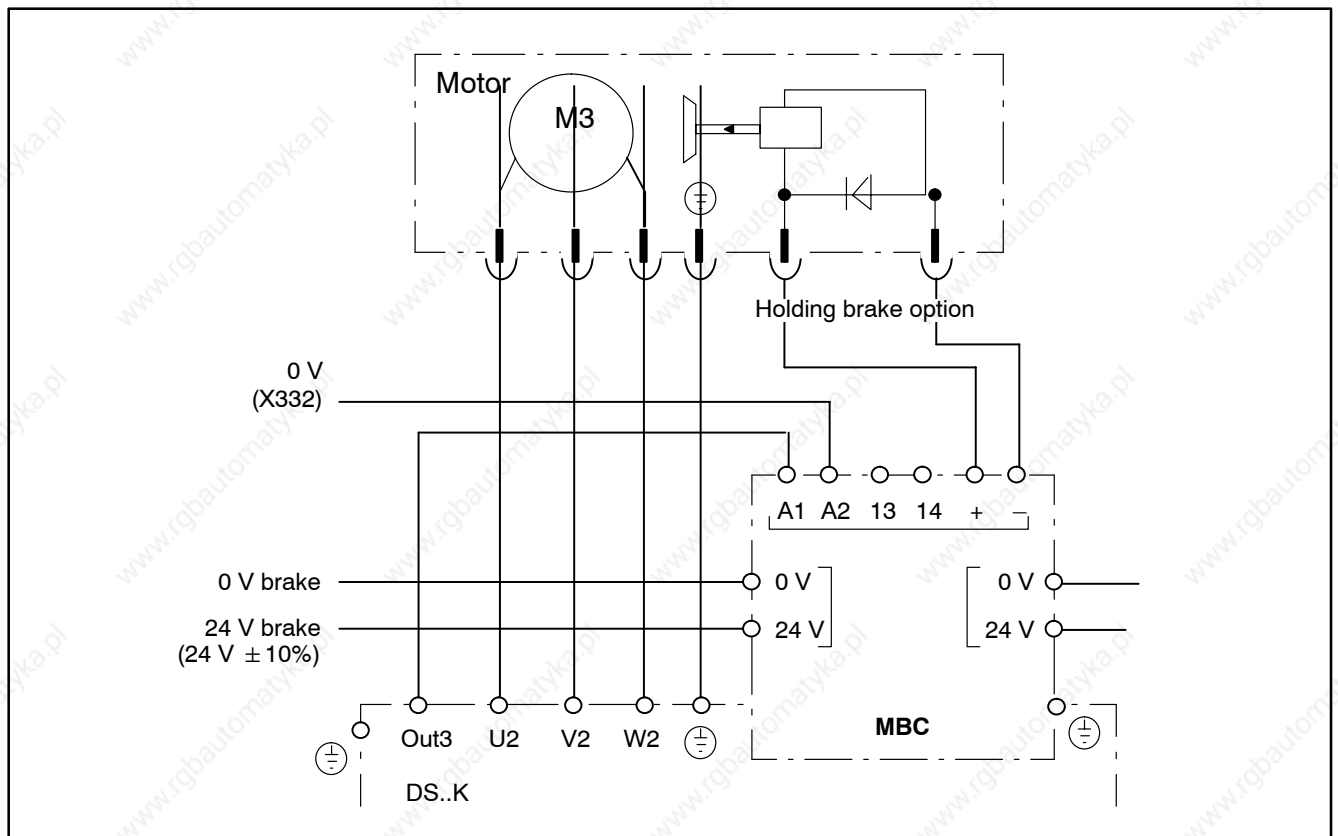
Connection with MBC (brake connection with relay and protective circuitry)**X34.3 Out 2 Temperature warning**

The temperature warning refers to:

- The heat sink temperature of the inverter
- The motor temperature.

When the warning temperature is exceeded, the warning signal changes from 24 V to LOW level. The warning temperature can be set in the range of 70...95% of the admissible temperature range.

X34.4/5/6 Out 1 Relay contact

Floating relay contact, to be connected as n.c.c. or n.o.c.
Max. load: 24V/1000mA.

Assignment	Interface		
	Analog interface	SERCOS interface	Other types
Default setting: X34.4/5 (n.o.c.)	Finished message following the output of the absolute encoder position available in the drive via X81. Cf. page 8-7.	Feedback FGI (no FGI = output stage disabled)	not programmable

DS control connections

7.7 RS 232 for commissioning and service system connection (DSS-D)

All inverters are equipped with an RS232 serial interface. This interface serves for connecting the DSS-D commissioning and service system to the individual modules.

Front panel X99

Sub-D connector, 9-pin

Transmission rate: 9600 bits/s

Parameters: even parity, 8 data bits, 2 stop bits

Handshake: Software handshake (X_{ON} , X_{OFF})



RX Receive Data

TX Transmit data, data transmission to DSS

GND signal ground

- ☞ **In order to avoid interference problems during commissioning, we recommend running the connection cable through an annular core. Use the folding ferrite coil, part no. 1070918766.**

DS control connections

7.7.1 Motor encoder (X05)

Each inverter module (except for ASM) is equipped with one of the following encoder interfaces:

- for gear encoders or single-turn encoders (STG) or multi-turn encoders (MTG)
- for resolvers (SR motors)

Every encoder interface comprises:

- encoder signals for position control and fine interpolation
- serial bidirectional interface to facilitate the transmission of motor data and absolute position (no absolute position for resolvers)
- encoder power supply
- additional connections for recording the motor winding temperature

The following gear encoders with an integrated electronic rating plate are permitted:

- Type **KWG2EP** made by Messrs. VS-sensorik
- Type **WG05-B** made by Messrs. Woelke



CAUTION

All plug connectors to the encoder may only be plugged or unplugged when the drive is off so as to avoid damage to the inverter or to the encoder!

Switch the drive off beforehand!

Encoder cables

We recommend using prefabricated Bosch encoder cables for the SF and SR servo motors. Depending on the individual case, these cables are available as

- Standard cable
- Highly flexible cable
- UL-conformant cable



UL encoder cables have to be used for UL/CSA-certified drive inverters in order to ensure that the entire system meets the UL/CSA requirements.



CAUTION

Damage to cables due to inadmissible movements.

Please note the technical data of the cables specified in the “Configuration” manual, part no. on page 1-7.

DS control connections

Prefabricated encoder cables, shielded					Standard	Highly flexible
	No of cores	Dimensions [kg/m]	For motor type	Encoder system	Part no. (5 m length)*	Part no. (5 m length)*
Cable	17 cores	0.14	SF, DU	ECN (single-turn) EQN (multi-turn)	1070919827	1070920850
			SR, other types	Resolver, gear encoder	1070917094	1070920989
Extension with coupling	17 cores	0.14	SF	ECN (single-turn) EQN (multi-turn)	1070920 06	1070921262
UL-conformant cable 	17 cores	0.16	SF, DU	ECN (single-turn) EQN (multi-turn)	107092 697	1070921701
			SR, other types	Resolver, gear encoder	on request	on request

* Part no. of cable lengths 7, 10, 12, 15, 20, 25, 35, 50, 100 m on request

Cable bushing (metal flange)

For cable bushings, e.g. leading into the switch cabinet, a metal flange may be used in connection with a cable extension and a coupling. The connector housing is clamped and sealed to IP 65 when installed.

Flange: Zinc diecasting, nickel-plated

Gasket: Viton, black

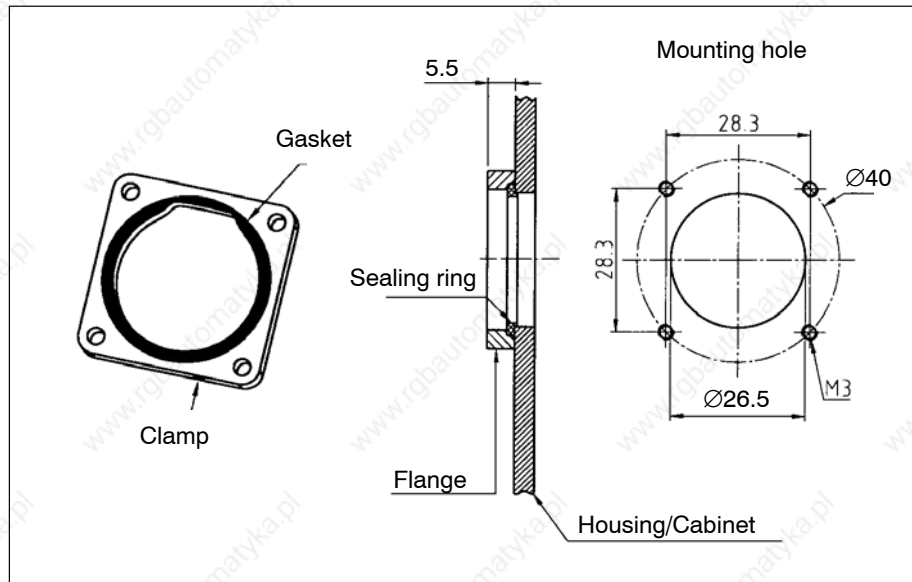

DS control connections

Pin assignment for encoder cable STG/MTG

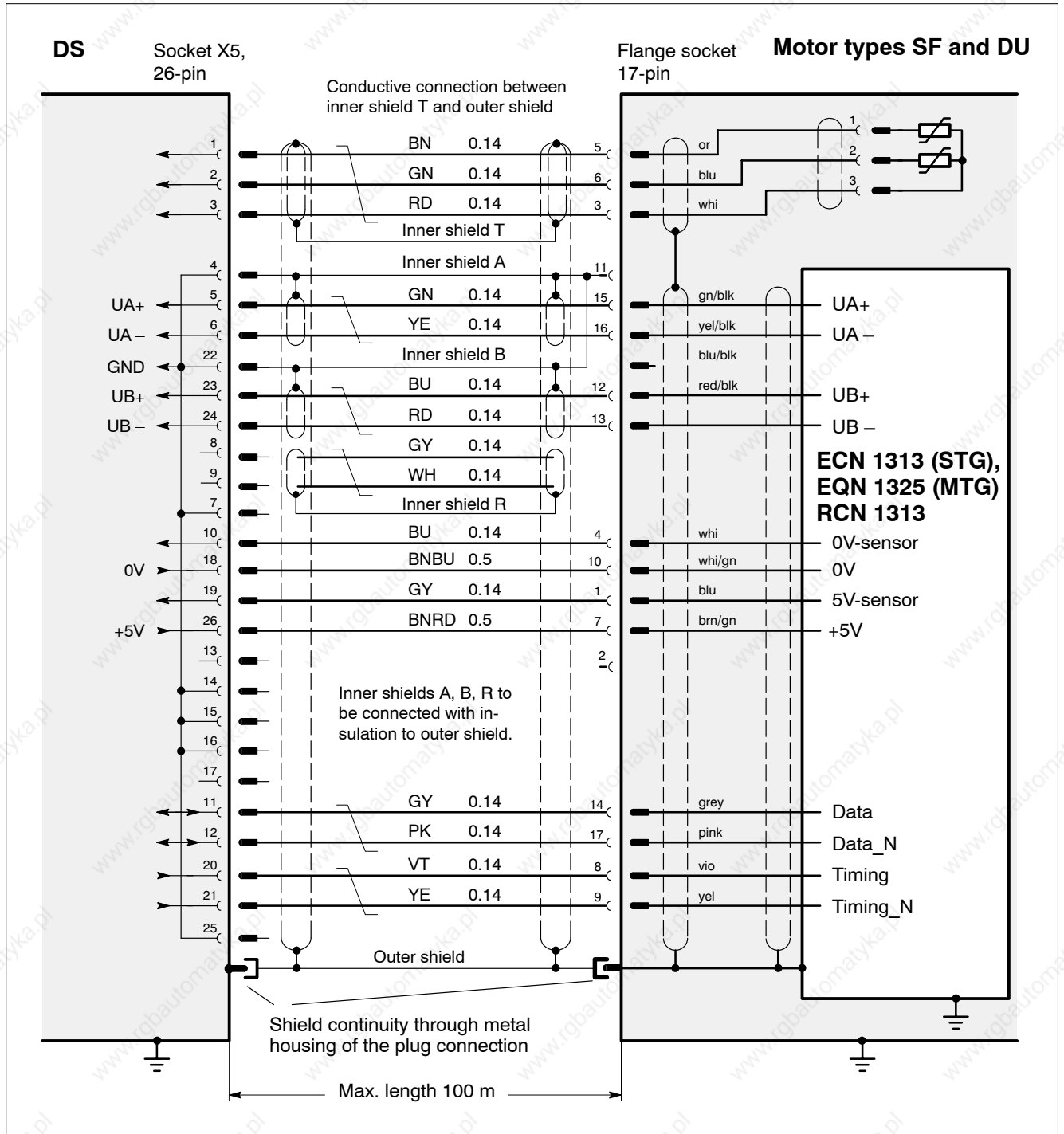

The outlined pin assignment only applies to cables and motor encoders supplied by Rexroth.

DS control connections

Pin assignment for encoder cable for gear encoder and resolver



The outlined pin assignment only applies to cables and motor encoders supplied by Rexroth

DS control connections

7.8 Encoder switch / encoder simulation (X81)

The X81 D-Sub connector provides the encoder signals of the motor:

- for inverters with an analog interface
- for inverters with positioning function (MC)

Encoder switch

If motors with integrated incremental encoders or gear encoders are used, X81 represents an encoder switch.

Encoder simulation

If SR motors with integrated resolvers are connected, X81 provides the resolver position data as standard incremental signals.

Output signals	U_{A1}, U_{A2}, U_{A0} $\overline{U_{A1}}, \overline{U_{A2}}, \overline{U_{A0}}$ U_{AS}
Signal level	Driver to RS 422 $U_{High} \geq 2.5 \text{ V}$ where $-I_{High} = 20 \text{ mA}$ $U_{Low} \leq 0.5 \text{ V}$ where $I_{Low} = 20 \text{ mA}$
Maximum load	$-I_{High} \leq 20 \text{ mA}$ $I_{Low} \leq 20 \text{ mA}$
Operating times	Rise time $t_+ \leq 100 \text{ ns}$ Fall time $t_- \leq 100 \text{ ns}$
Voltage supply	$5 \text{ V} \pm 5\%$
Power input	$\leq 50 \text{ mA}$ without load
Min. edge interval a	$\geq 100 \text{ ns}$ (programmable with DSS-D, depends on output frequency)
Output frequency	$\leq 1 \text{ MHz}$ (programmable with DSS-D, depends on line number and max. motor speed)
Line number	$\leq 16\ 383$ (programmable with DSS-D, depends on max. motor speed)

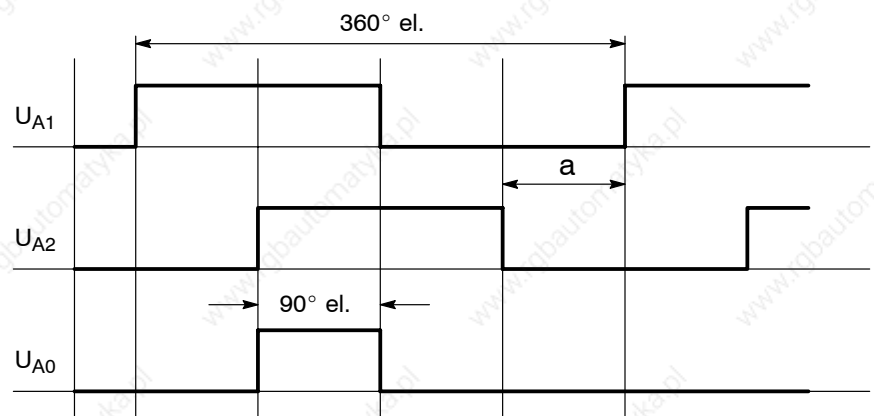

DS control connections

Pin assignment for encoder switch/encoder simulation



Prefabricated cables are available for connection; for part numbers, refer to page 11-1.

DS control connections

7.9 Direct measuring system connection (X55)

Differing direct position measuring systems can be connected via various option modules type OM to inverters with SERCOS interface:

- OM 01-D Incremental measuring systems with sinusoidal current signals
- OM 02-D Digital incremental measuring systems
- OM 03-D Incremental measuring systems with sinusoidal voltage signals, or absolute measuring systems with EnDat or I²C interface



CAUTION

**Damages at the inverter or measuring system by inserting or removing plug-in connections on live systems!
Switch the drive off beforehand!**

- ☞ **Exchanging the signal leads to facilitate direction change is not permissible due to the assignment of the reference pulse. A counting direction change is achieved by setting the appropriate parameters.**

DS control connections

OM 01 Incremental measuring systems with sinusoidal current signals

This option module contains an integrated EXE module with five-times interpolation.

Technical data

- Input for measuring system with +5 V power supply and sinusoidal current signals 7...16 μA_{pp}
- Signal input: Difference amplifier
- Power supply: +5 V +1%/-5%
- max. permissible power input of the measuring system: $\leq 300 \text{ mA}$
- EXE separation factor: 5-times interpolation
- Pulse multiplication: programmable x1, x2, x4
- max. input frequency: $\leq 50 \text{ kHz}$
- Measuring system monitoring: Response to input signals in channels I_{e1} or $I_{e2} \leq 4.3 \mu\text{A}$
- max. cable length: $\leq 20 \text{ m}$ or shorter, cf. manufacturer's data
- Pin assignment: see manual "Interface Conditions"

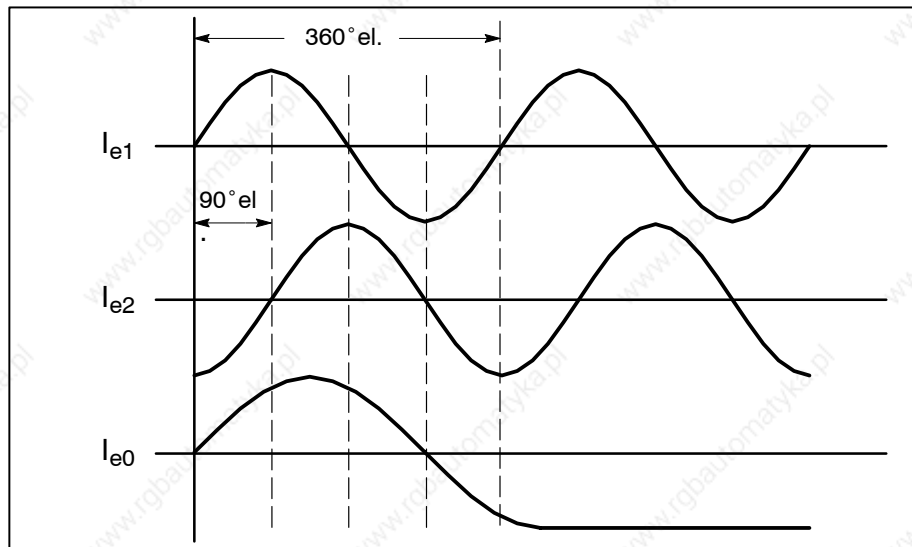
Signal diagram

Heidenhain measuring systems which fulfill the following conditions can generally be used (For further information, refer to manual "Configuration ServoDyn D"):

- Measuring system for 5 V power supply from option module
- Sinusoidal current signals 7...16 μA_{pp}
- Power input $\leq 300 \text{ mA}$
- Max. output frequency 50 kHz

The cable shield must have a continuous connection from the front panel of the option module to the measuring system.

DS control connections

Pin assignment OM 01 for measuring systems with sinusoidal current signals



☞ **Metal connector covers must be used for the 9-pin coupling (Heidenhain-ID-No. 228 562 01 or 237 525 04) on the measuring system side and the 15-pin sub-D connector on the option module! Cable shielding must have large-surface contact with the strain-relief clamp!**

For prefabricated cables, refer to page 11-1.

DS control connections

OM 02 Digital incremental measuring systems**Technical data**

- Input for measuring system with +5 V power supply and square-wave signal output with line driver to RS422
- Signal input: Difference amplifier, $R_i \approx 120 \Omega$
- Power supply: +5 V $\pm 3 \%$,
regulated via sensor leads
- max. permissible power input of the measuring system: $\leq 300 \text{ mA}$
- Pulse multiplication: programmable x1, x2, x4
- max. input frequency: $\leq 1 \text{ MHz}$
- min. edge interval a between active counting pulses: $\geq 150 \text{ ns}$
- min. edge interval b in case of sense of rotation reversal: $\geq 0 \text{ ns}$
- min. safety clearance c for reference signal: $\geq 100 \text{ ns}$
- Measuring system monitoring: a) for cophasal state of channels
UA1, UA2 or UA0 $\geq 1.2 \mu\text{s}$
b) Evaluation of $\overline{\text{UAS}}$
- max. cable length $\leq 50 \text{ m}$ or shorter if required by manufacturer
- Pin assignment see manual "Interface Conditions"

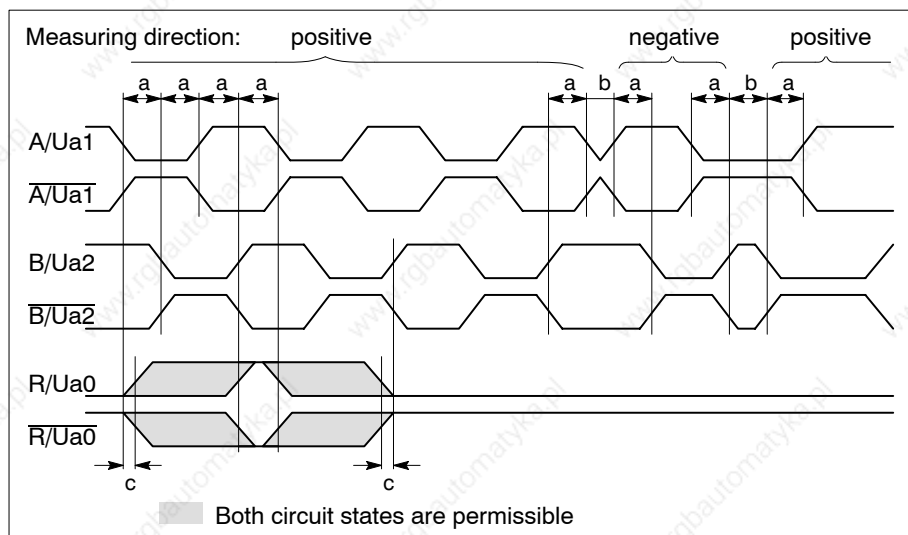
Signal diagram

Heidenhain measuring systems which fulfill the following conditions can generally be connected to the option module OM 02 (for recommended types, refer to "Configuration" manual):

- Measuring system for 5 V power supply from the option module

DS control connections

- Square-wave signal output
- Line drivers acc. to RS 422
- Power input ≤ 300 mA
- Min. edge interval between active counting pulses ≥ 150 ns

The cable shield must have a continuous connection from the front panel of the option module to the measuring system.

A measuring system error is signalled to the OM 02-D option module by means of an input signal \overline{U}_{AS} , or when the connected measuring systems/EXEs switch their output stages to the tri-state status (high-resistance).

Open \overline{U}_{AS} inputs are set to HIGH potential by internal pull-up resistors (= no measuring system error present).

Pin assignment OM 02 for measuring systems with square-wave signals

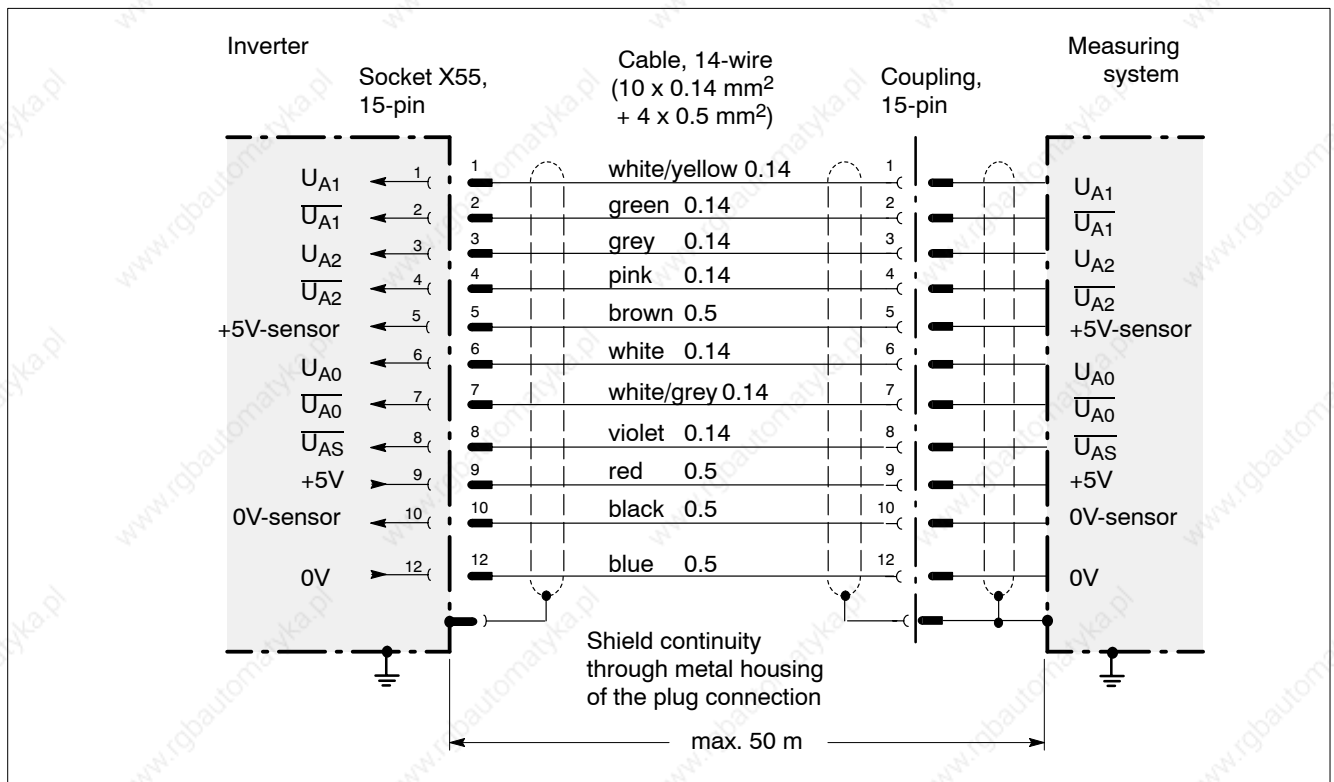

DS control connections

Permissible pulse-shape electronics (EXE)

Heidenhain EXEs can also be connected subject to the following conditions (For further information, refer to manual “Configuration ServoDyn D”):

- EXEs for 5 V power supply from the option module or for external 230 V AC voltage supply
- Square-wave signal output
- Line drivers acc. to RS 422
- Max. power input for measuring system **and** EXE with 5 V supply: ≤ 300 mA
- Min. edge interval between active counting pulses ≥ 150 ns

Please follow the manufacturer’s recommendations when combining measuring systems and EXEs. Measuring systems and EXEs with internal monitoring are preferably used.

The connection between the measuring system and the EXE is effected via a cable supplied by Heidenhain. The cable shield must have a continuous connection from the front panel of the option module to the measuring system. The correct wiring of the U_{AS} signal must be checked.

Pin assignment OM 02 for pulse-shape electronics (EXE)



DS control connections

OM 03 Incremental measuring systems with sinusoidal voltage signals, absolute measuring systems with EnDat or I²C interface

The OM 03 supports measuring systems without a serial interface, with EnDat or I²C interface.

It is available in 2 different versions with different input frequencies:

- OM 03: ≤ 500 kHz
- OM 03 (125 kHz): ≤ 125 kHz

The following direct measuring systems may be connected:

- High-resolution rotary encoders
- Linear scales
- Gear encoders

All measuring systems must meet the following interface requirements: (For further information, refer to manual "Configuration ServoDyn D"):

- Measuring system for 5 V power supply from option module
- Incremental signals 1 V_{pp}
- Power input ≤ 300 mA
- Signal frequency ≤ 125 kHz / 500 kHz
- Cable length ≤ 100 m

Signal diagram

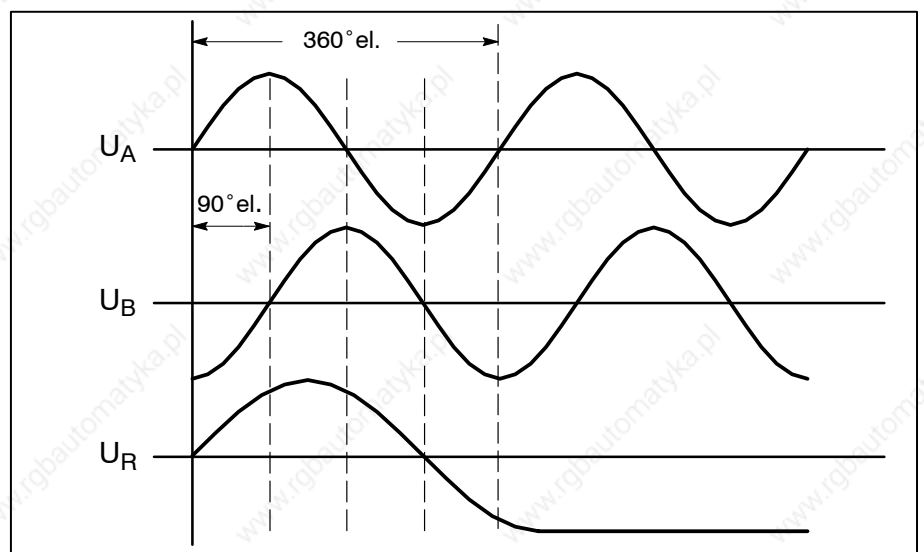

The external cable shield must have a continuous connection from the front panel of the option module to the measuring system.

The inner cable shields A, B and R must be connected with insulation to the outer shield.

DS control connections

Pin assignment OM 03 for measuring systems with EnDat interface



DS control connections

Pin assignment OM 03 for measuring systems without interface or with I²C interface

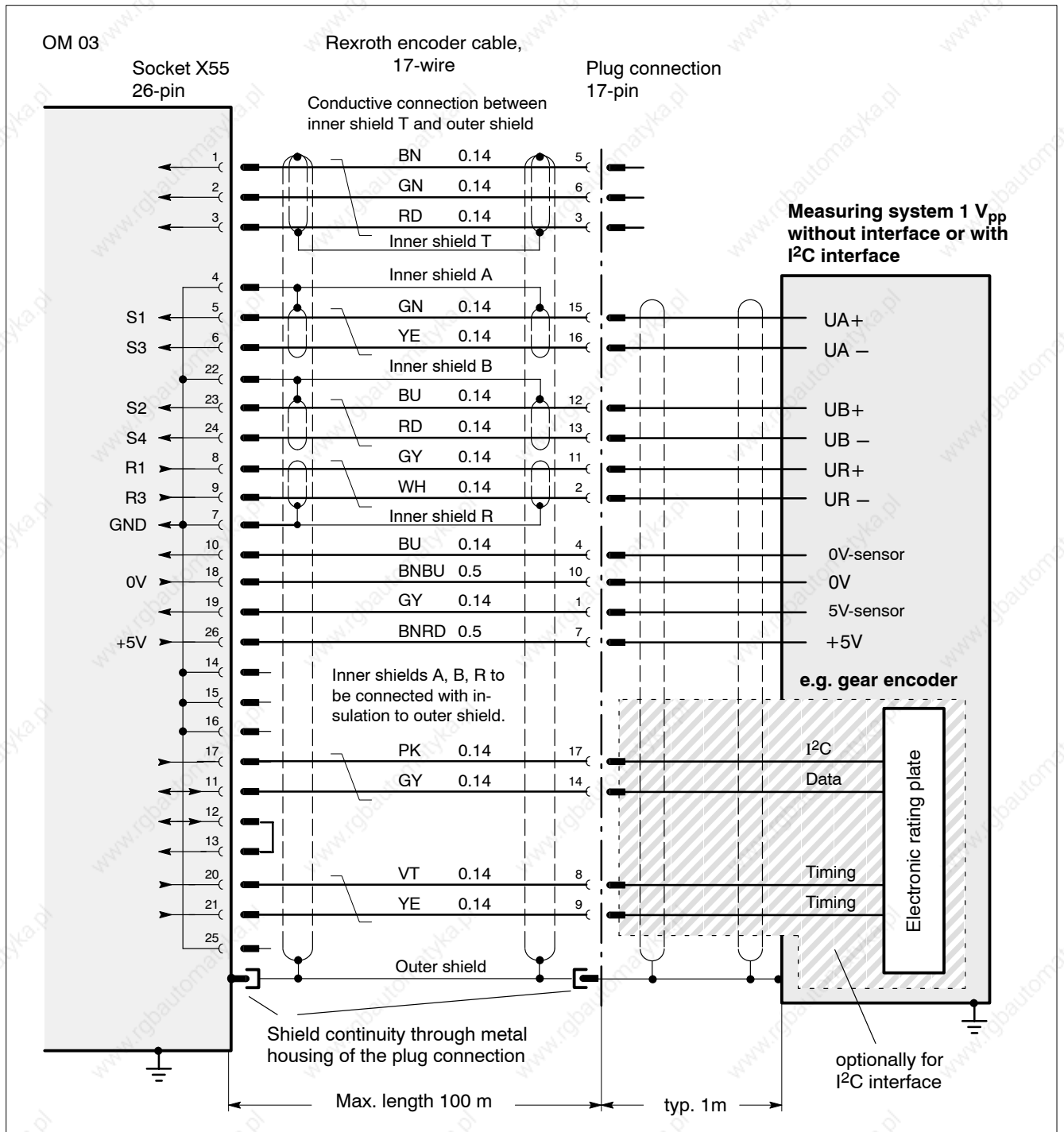

DS control connections

7.10 High-speed analog outputs OM 04

The OM 04 option module can be used for:

- all inverters except frequency inverter DS..8001 (ASM)

Terminal strip X13

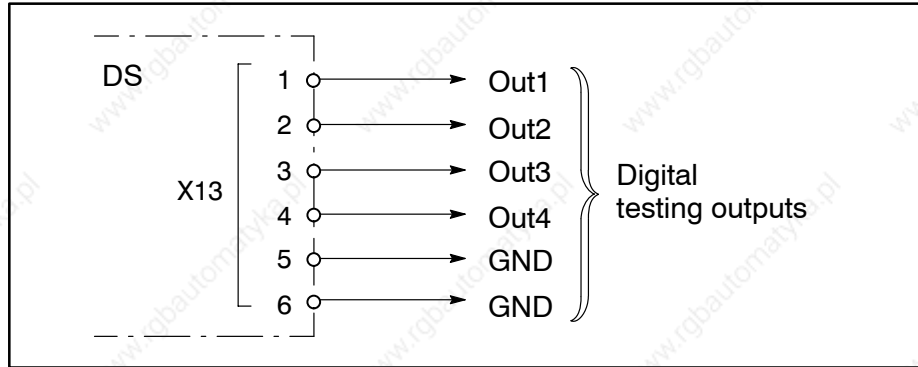

X13.1-4 D_Out1 to D_Out4 Programmable 5 V testing outputs

Output resistance 120 Ω, short-circuit-proof.

The test signals at X13 are designed for service personnel.

Terminal strip X14

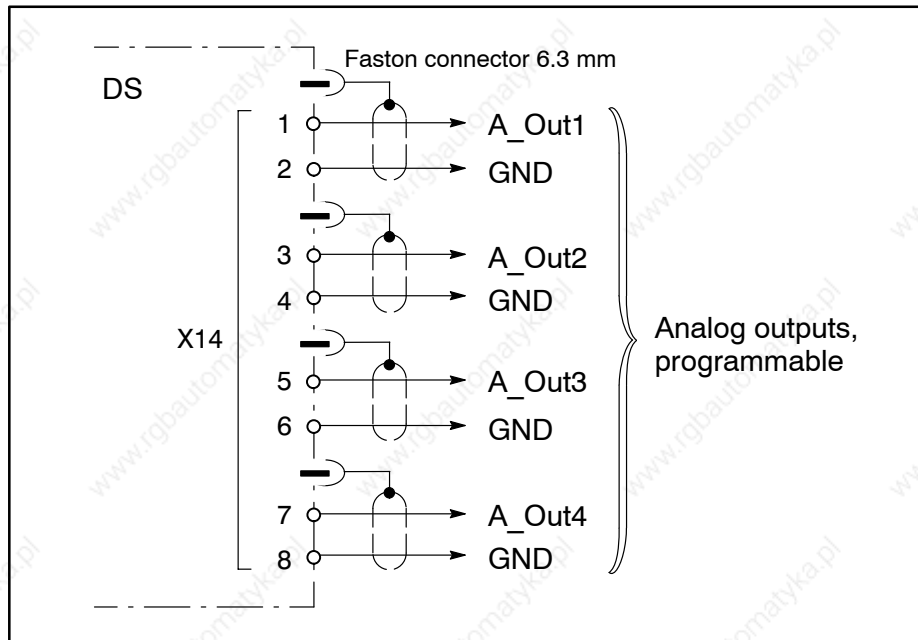

DS control connections

X14.1–4 A_Out1 to A_Out4 Programmable HS-analog oputputs

Output voltage range ± 10 V, output resistance 100 Ω , short-circuit-proof.

The programmable high-speed analog signals serve as measured value output.

- 12-bit resolution
- Accuracy $\pm 0.3\%$ of the final value
- max. connectable cable length 10 m

When the module is switched on, the outputs are not defined until initialization. During initialization, they are reset to zero.

Default setting	Analog interface, SERCOS interface CAN bus PROFIBUS-DP	Positioning function (MC)
X14.1/2 (A_Out1)	Speed setpoint S-0-0036	–
X14.3/4 (A_Out2)	Actual speed S-0-0040	–
X14.5/6 (A_Out3)	Torque setpoint S-0-0080	–
X12.7/8 (A_Out4)	Torque actual value S-0-0084	–

DS control connections

Notes:

Application instructions

8 Application instructions

8.1 Drive with SERCOS interface

8.1.1 Cycle power to the drive

24 V hardware signals:

- **Enable external FG (X06.3)**
Hardware enable for each axis:
 - Without the FG signal the motor torque is zero and the motor comes to a stop without setpoint control.
 - Braking is effected by means of a plug braking module or by using a holding brake integrated into the motor.

 **The holding brake can only be operated at standstill, in order to avoid dangerous wear and tear. Refer to the motor manual.**

SERCOS interface signals (Rexroth PLC command designations):

- **Drive enable** **(Drive inhibit)**
Software enable for each axis:
 - The software signals “Drive on” and “Drive hold” function only with Drive enable.
 - Without “Drive enable” the motor torque is zero and the motor comes to a stop without setpoint control.
 - Braking possible via a plug braking module
- **Drive on** **(Drive off)**
switches the internal Enable signal:
 - switches on the torque when “Drive enable” has been given
 - With Drive on, the setpoints become active after the “Waiting time Drive on” has elapsed. This is necessary for controlling a holding brake (cf. motor manual)
 - Deceleration of drive in accordance with P-0-0004 with “Waiting time Drive off” for brake control. Followed by torque switch off.
- **Drive hold** **(Feed inhibit)**
Shut-down drive with setpoint control, if “Drive on” is activated:
 - taking into consideration P-0-0004
 - drive remains under control

Application instructions

Sequence diagram with SERCOS interface: Cycle on / off

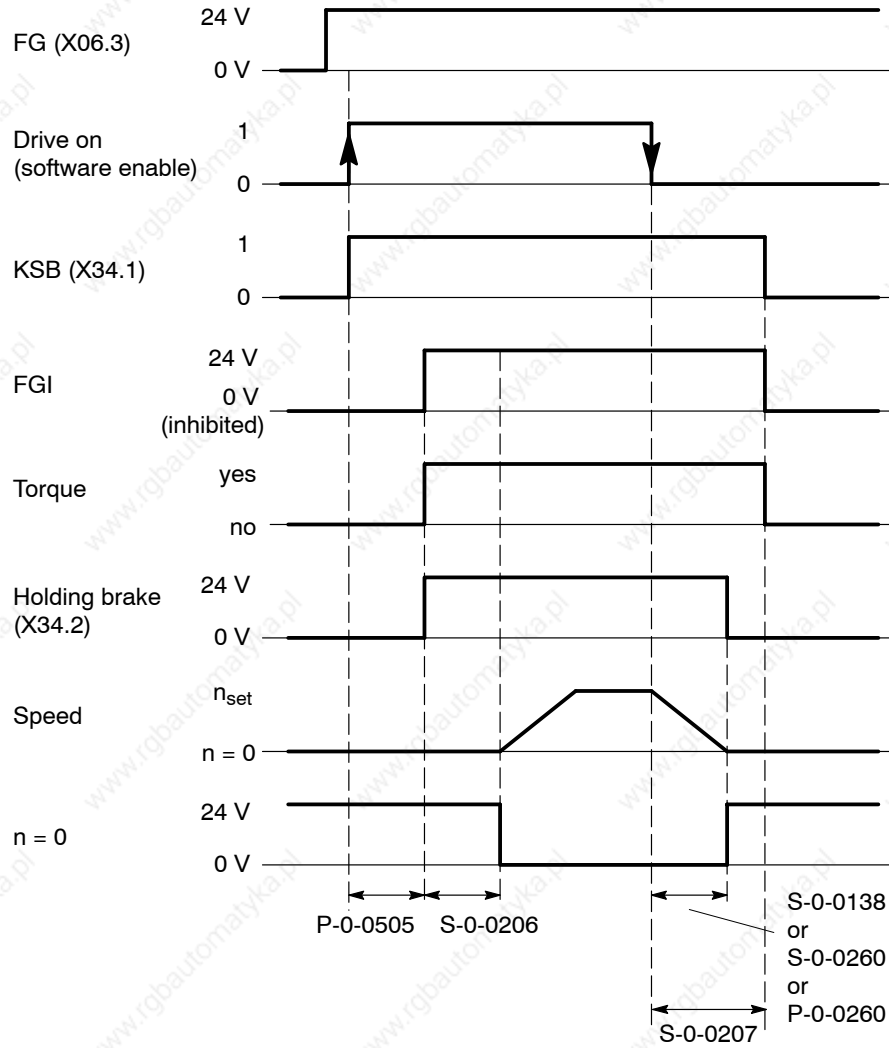

- FG off: drive comes to a stop without setpoint control
- "Drive on" off: drive is braked according to preselection in P-0-0004
- "Drive enable" off: drive comes to a stop without setpoint control

Application instructions

Sequence diagram with SERCOS interface: Cycle off / on upon entering a protective zone

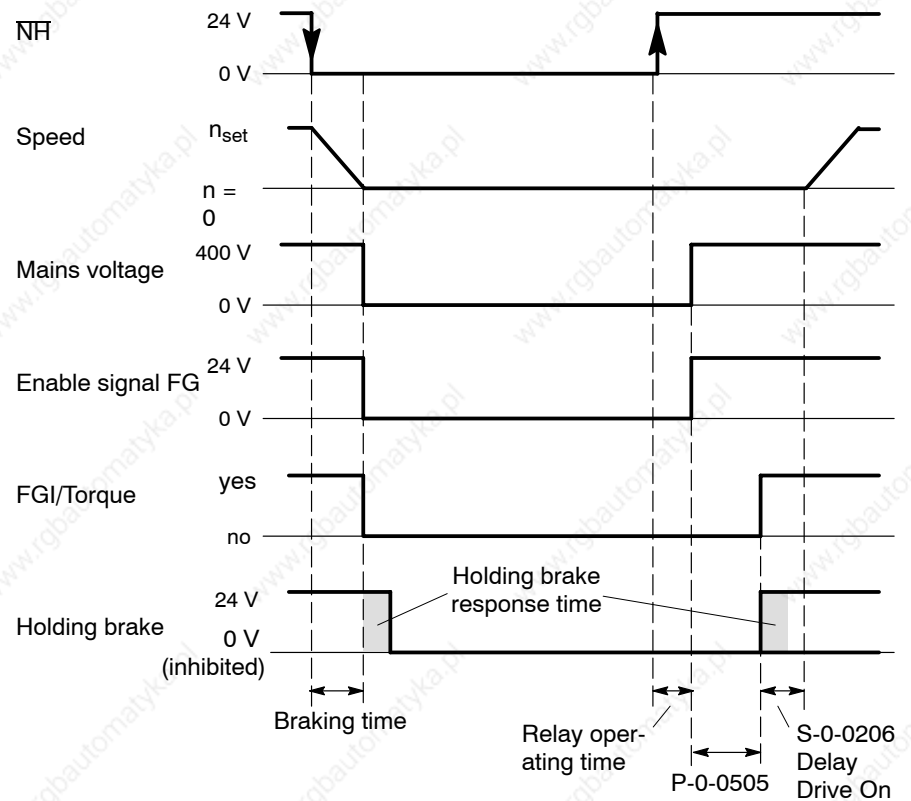

DANGER
Do not use for suspended axes!

**Cycle off**

The FG enable signal must remain active during the braking time via a time relay before the mains voltage and FG are switched off, otherwise, the holding brake will engage immediately.

Cycle on:

The mains voltage and FG are connected simultaneously. In order to avoid a VM error which may occur because the DC link is no longer fully charged, there must be a delay before activating the internal enable signal. This is done with the help of parameter P-0-0505 (KSB (plug braking) enable delay).

The internal enable signal (FGI) applies a torque to the motor and releases the holding brake. The response time of the holding brake is typically 80 ms with the relay connected in series. No traversing command may be carried out during this time. For this purpose, parameter S-0-0206 (Waiting time drive on) is set (typically 100 ms).

Application instructions

8.1.2 EMERGENCY-STOP

Emergency-Stop tripping delay

To initiate EMERGENCY-STOP, the Emergency-Stop input \overline{NH} of the DS inverter must be interrupted, cf. page 6–6.

By activating EMERGENCY-STOP, the system automatically changes over from position control of the master (CNC) to speed control in the drive and the function “Drive halt” is initiated, which can be defined individually for each axis in P-0-0004:

- Braking within shortest possible time (S-0-0138)
- Braking drive-controlled via ramp (S-0-0260)
- Braking drive-controlled via separate halting ramp (P-0-0260)
- Braking setpoint-controlled by the master

The DS inverter does not interrupt the power supply unless all axes have been halted, but not later than after the permanently set tripping delay time of 16 s.

☞ **The control remains active during the tripping delay, then the power is cut off and the drives come to a stop without setpoint control.**



DANGER

**In the event of a supply module failure, the motors have no torque and come to a stop without setpoint control!
Activate plug braking or an integrated holding brake in this case.**

Application instructions

Sequence diagram with SERCOS interface: EMERGENCY-STOP

The following signals (PLC commands) have to be given:

- External enable FG (24 V to X06.3)
- Drive enable (Drive inhibit) (drive control word, bit 14 = 1)
- Drive on (Drive off) (drive control word, bit 15 = 1)
- Drive $\overline{\text{hold}}$ (Feed inhibit) (drive control word, bit 13 = 1)

**DANGER**

Drive braking cannot be controlled without enable FG and “Drive enable”.

The 24 V supply to the module must be maintained.

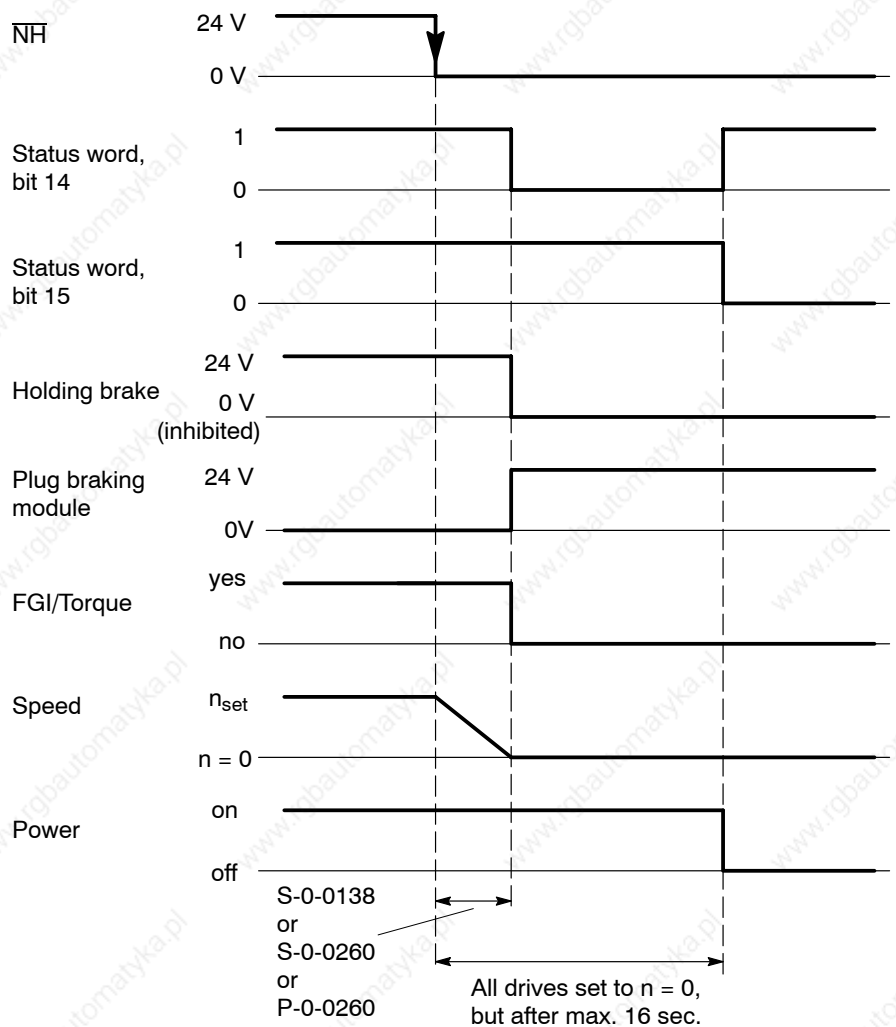

Application instructions

8.2 Drive with analog interface, MC, CAN bus, PROFIBUS-DP

24 V hardware signals:

- **Enable external FG (X06.3)**
Hardware/software enable for each axis:
When FG is switched off, the motor is braked as specified in P-0-0125.

☞ **The holding brake may only be operated at standstill, in order to avoid dangerous wear and tear. Refer to the motor manual.**

Sequence diagram

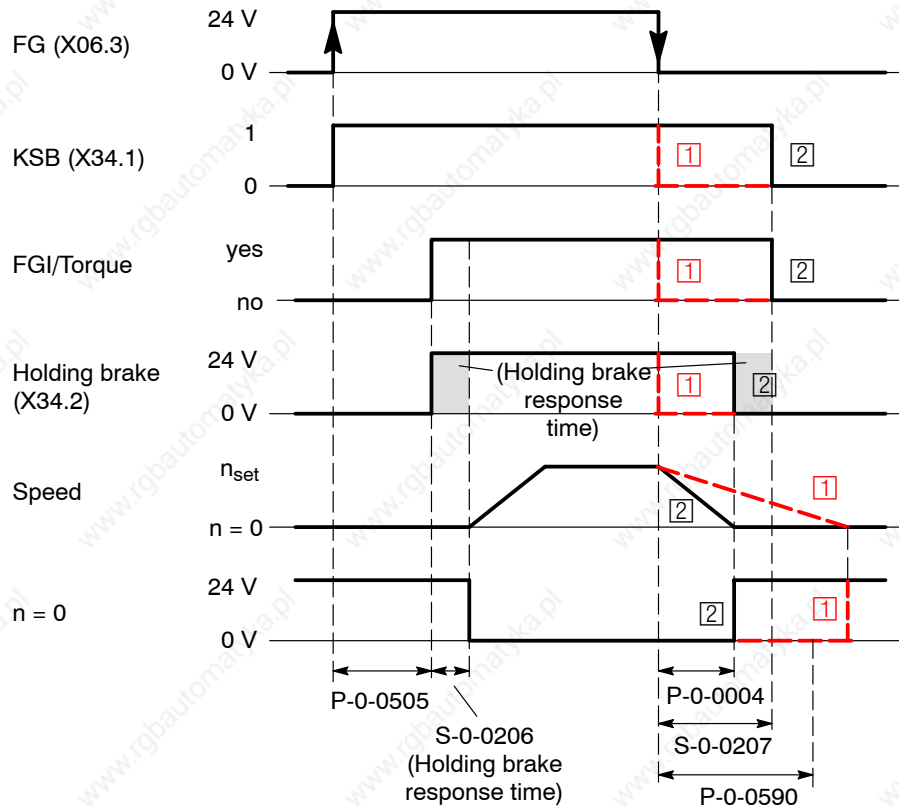

Halting the drive in accordance with parameter P-0-0125:

- ☐ 1 : Motor comes to a stop without setpoint control
- ☐ 2 : Halting as specified in P-0-0004 (shortest possible time S-0-0138 or ramp S-0-0260 or P-0-0260)

Maximum time until the output stage is switched off: P-0-0590, if activated.

Application instructions

8.3 Transmission of the absolute encoder position with X81

The transmission of the absolute encoder position is used for ServoDyn D with analog interface.

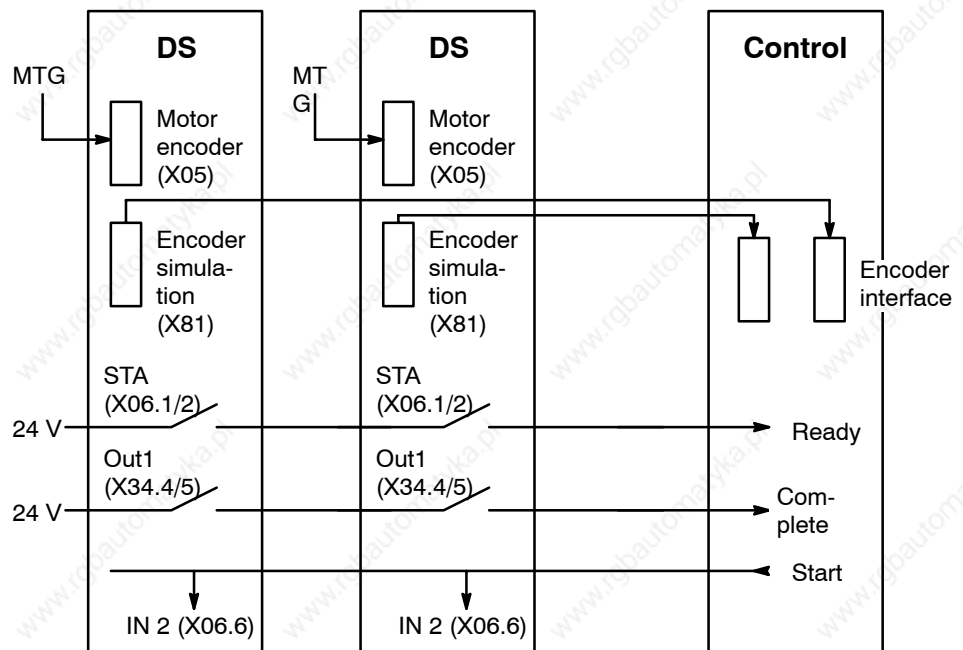
Function chart

MTG = multiturn absolute value encoder

★ **Sequence of transmission of the absolute encoder position:**

- The drive signals ready status through the STA status relay.
- No enable signal is output for the drives and the control.
- The control outputs a 24V start signal for IN 2 (only 1st pulse takes effect).
IN2 may only be output if:
 - STA of the axis has been output and
 - Out 1 = 0, i.e. no Complete message.
- With the start signal at IN2, the drive starts transmitting the impulses of the absolute position to the control (connection between encoder simulation – encoder interface).
- When transmission is complete, the drive sets the relay contact Out1, thus generating a 24V signal as Complete message for the control (finished). The relay contact Out1 must be used as normally-open contact. It can only be reset by RESET or by toggling the 24 V supply to the drive off/on.
- When the control has received the Complete message, it can enable the drive.

Application instructions

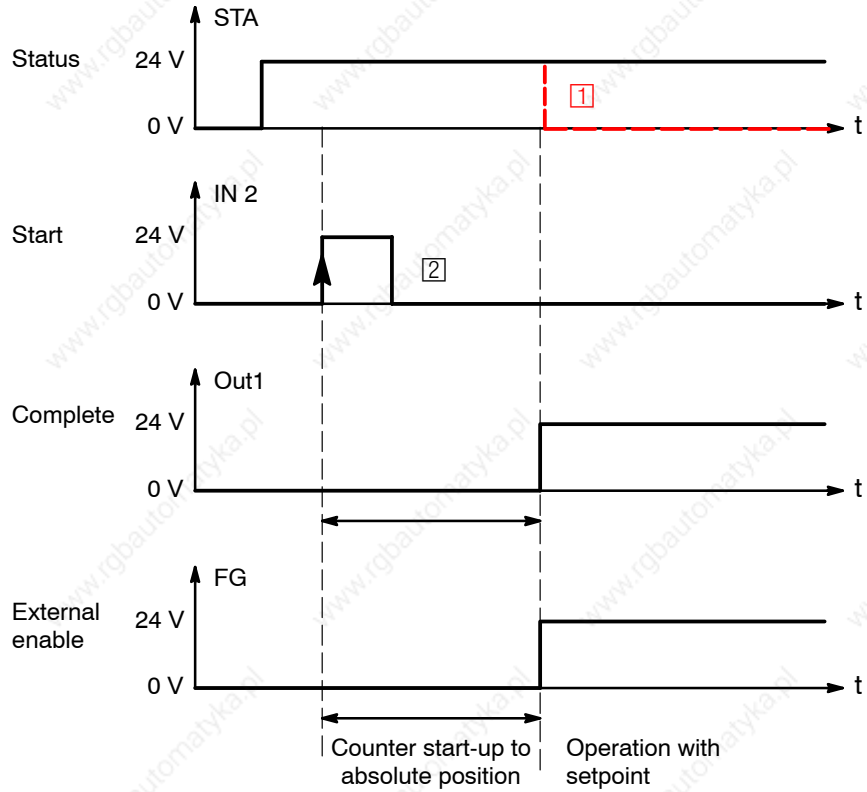

1 If the status relay is switched off due to an error when the counter has started up, transmission of the absolute value is no longer affected. Out1 remains high, transmission does not have to be re-started.

2 Start impulse will be sufficient as of software version 0.005.

Application instructions

Sequence on the control side

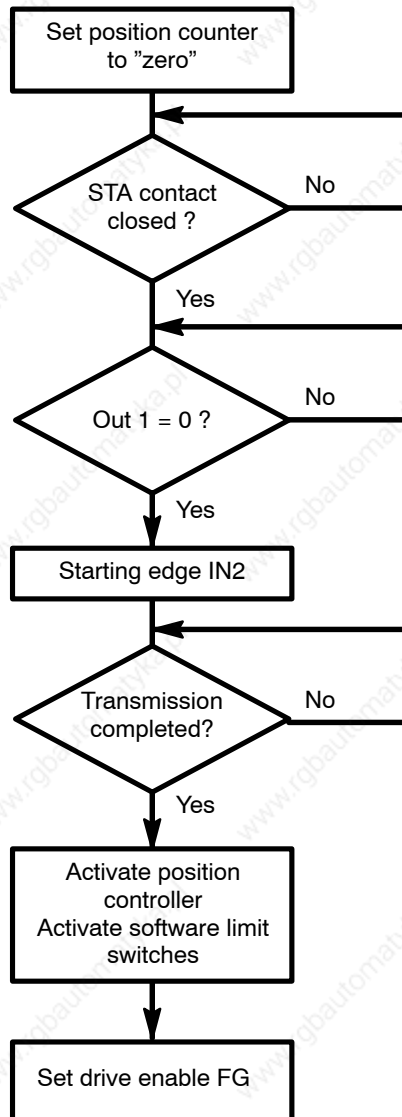

Application instructions

8.4 Drives with positioning function

ServoDyn D drives with positioning functions can be operated from the MC user interface (DSS-MC) of the DSS-D commissioning and service system. Refer to “Commissioning manual with motion control”, part no. on page 1–7.

This user interface offers password-protected change-over between operation by the hardware inputs and operation by the DSS-MC.

 **During operation by the MC user interface, all hardware inputs and outputs are inhibited, except IN 9 (reference cam input).**

The following modes may be selected via the user interface or hardware inputs IN 7 and IN 8:

Mode	Bit pattern of hardware inputs		
	IN 8	IN 7	
Automatic	0	0	
Referencing	0	1	
Jogging	Jog –	1	0
	Jog +	1	1

8.4.1 Jogging mode

In jogging mode, the drive can be traversed manually without referencing and without processing certain blocks.

Hardware inputs Jog+/Jog–

If 24 V are present at input IN 6 (start motion) and Jog+ or Jog– are activated (cf. above), the drive traverses in the direction thus specified until IN 6 is reset to 0 V.

The jogging speed is set with S-0-0259/S-0-0260 and can be influenced with S-0-0108 (feedrate override).

The override value 0 – 100% can be set using the MC user interface.

MC user interface

When the user interface is enabled, command buttons “+”, “–” start an axis movement in the corresponding direction. The override value can be set in the range 0 – 100%.

The MC user interface displays the positions traversed to.

Application instructions

8.4.2 Referencing

For automatic operation, the axis must have been referenced. The output signal "Axis has been referenced" is cleared when referencing is started, and set when referencing has been properly completed.

- Referencing direction according to S-0-0147, bit 0
- Referencing speed according to S-0-0041
- Referencing acceleration according to S-0-0042

Referencing movement in referencing direction

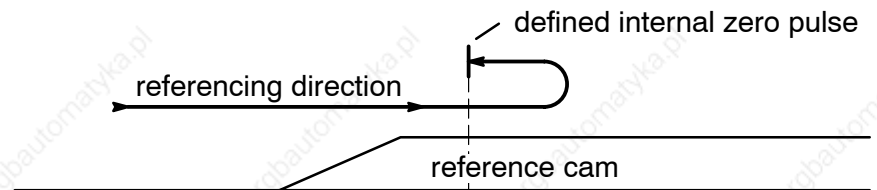

Referencing movement when axis has reached the cam

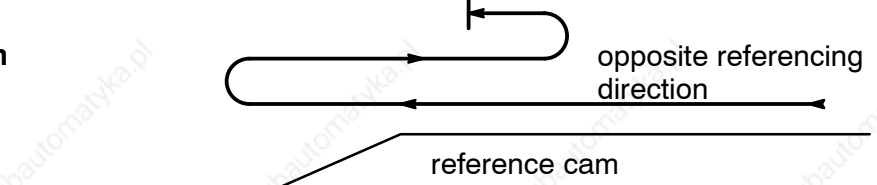

 **Motors with absolute encoders do not have to be referenced.**

Signal behavior

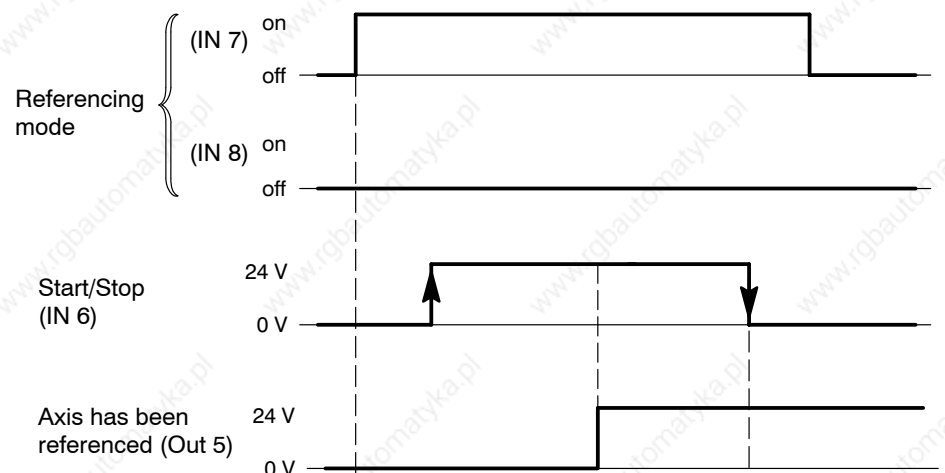

Application instructions

8.4.3 Automatic mode

In automatic mode, the user program is processed in the form of a position table. The position table can be created with the help of the MC user interface. It is automatically stored in the drive (example):

Block no.	Position absolute / incremental [mm]	Speed [mm/sec]	Acceleration [mm/sec ²]	Deceleration [mm/sec ²]
0	145a	1000	2000	2000
1	-20i	500	20	2000
.... etc., max. 32 blocks (= positions)				

With **absolute** position data, the target position is indicated, with **incremental** position data, the axis performs a relative movement by the specified value.

Examples of the syntax of position "100":

```
absolute: 100
          100a
          100abs
incremental: 100i
            100□ ... □i
            100incremental
```

Signal behavior

In automatic mode, the Start/Stop command initiates processing of the table set selected at inputs IN 1 – IN 5. Each block is released again, so that any block order can be selected.

Application instructions

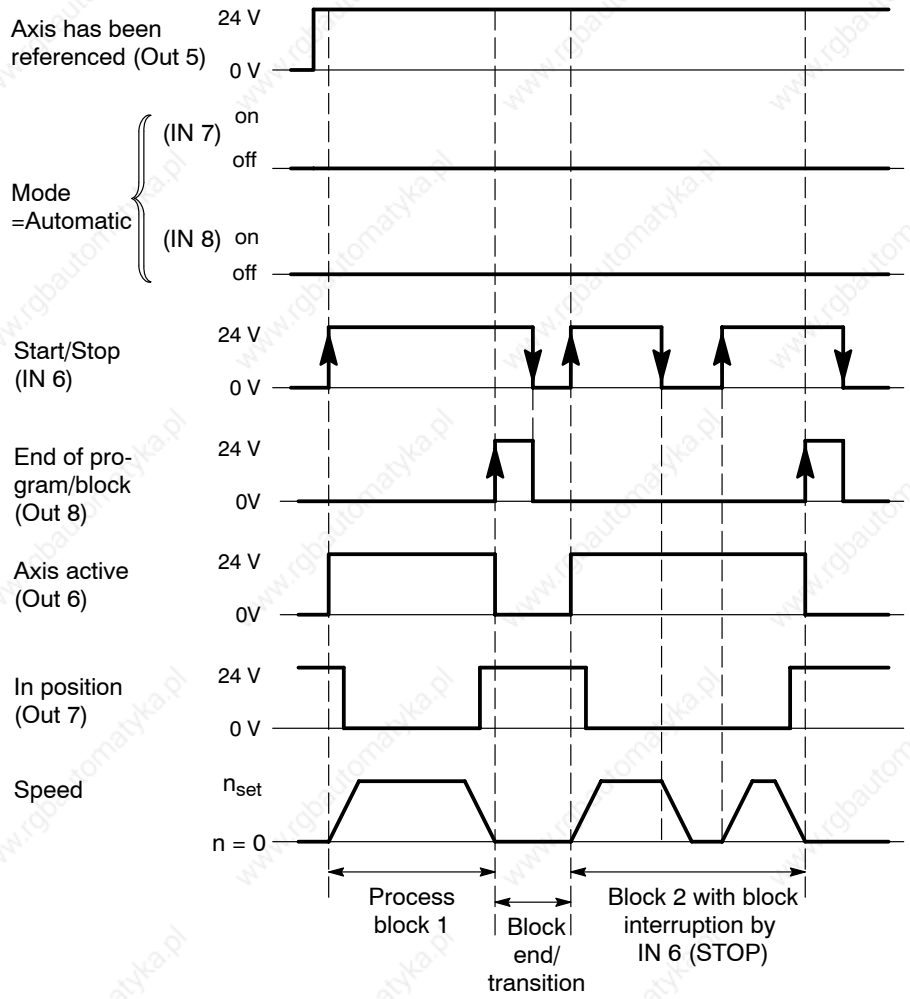

Application instructions

Notes:

Personality module

9 Personality module

The personality module is used in stand-alone inverters with SERCOS interface.



CAUTION

Damages possible by improper handling!

The Personality Module must not be inserted or removed unless the drive is switched off.

FEPROM

This plug-in board for the computer motherboard contains the FEPROM memory for the operating software and parameters and the dip switches for the basic setting for the SERCOS interface.

The personality module determines the drive inverter's behavior and can take control of the drive characteristics following a module exchange when simply plugged into the new module.

DIP switch on PM..A

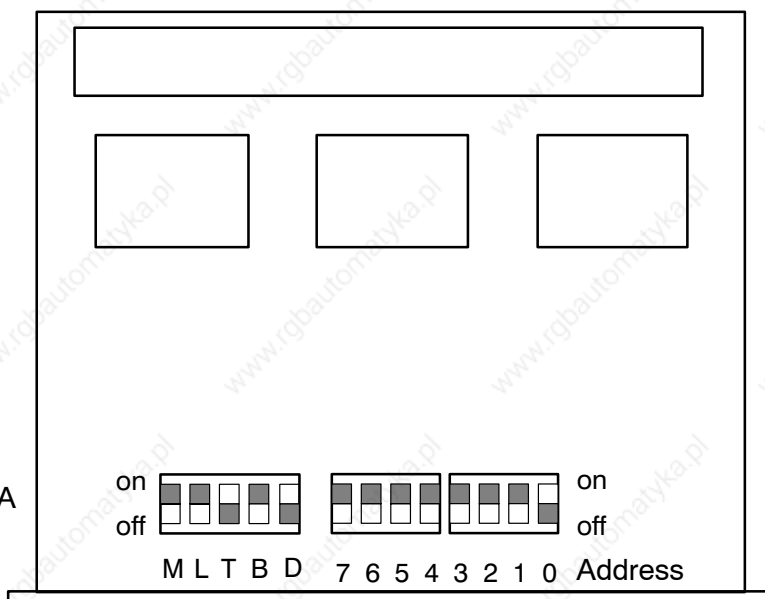

















Personality module

DIP switches

These switches must be set and tested before commissioning:

DIP switch	Function
<p>M</p> <p>on </p> <p>off </p>	<p>Select master function:</p> <p>SERCOS interface is master (default)</p> <p>DSS-D is master</p>
<p>L</p> <p>on </p> <p>off </p>	<p>Length of the optical fibre at the SERCOS interface transmitter:</p> <p>Cable up to a length of 10 m, limited transmission performance (default)</p> <p>Cable exceeding the length of 10 m, high transmission performance</p>
<p>T</p> <p>on </p> <p>off </p>	<p>Test SERCOS interface:</p> <p>Test mode</p> <p>Normal operation (default)</p>
<p>B</p> <p>on </p> <p>off </p>	<p>Data transmission rate::</p> <p>2 Mbaud (default)</p> <p>4 Mbaud</p>
<p>D</p> <p>on </p> <p>off </p>	<p>Combination with RSU modules:</p> <p>Operation together with RSU modules (cf. RSU manual)</p> <p>Operation together with standard modules (default)</p>

SERCOS interface module address:

	7	6	5	4	3	2	1	0	
on									0
off									1
	2^7	2^6	2^5	2^4	2^3	2^2	2^1	2^0	Significance
									Example address:
	0	0	0	0	0	0	0	1	1
	0	0	0	0	0	0	1	0	2
	0	0	0	0	0	0	1	1	3
	0	0	0	0	0	1	0	0	4

Not allowed are:

- "On" setting for all DIP switches
- "Off" setting for all DIP switches

Dimensioned drawings

10 Dimensioned drawings

10.1 Dimensioned drawing, line wiring module NV with stand-alone inverters DS..K

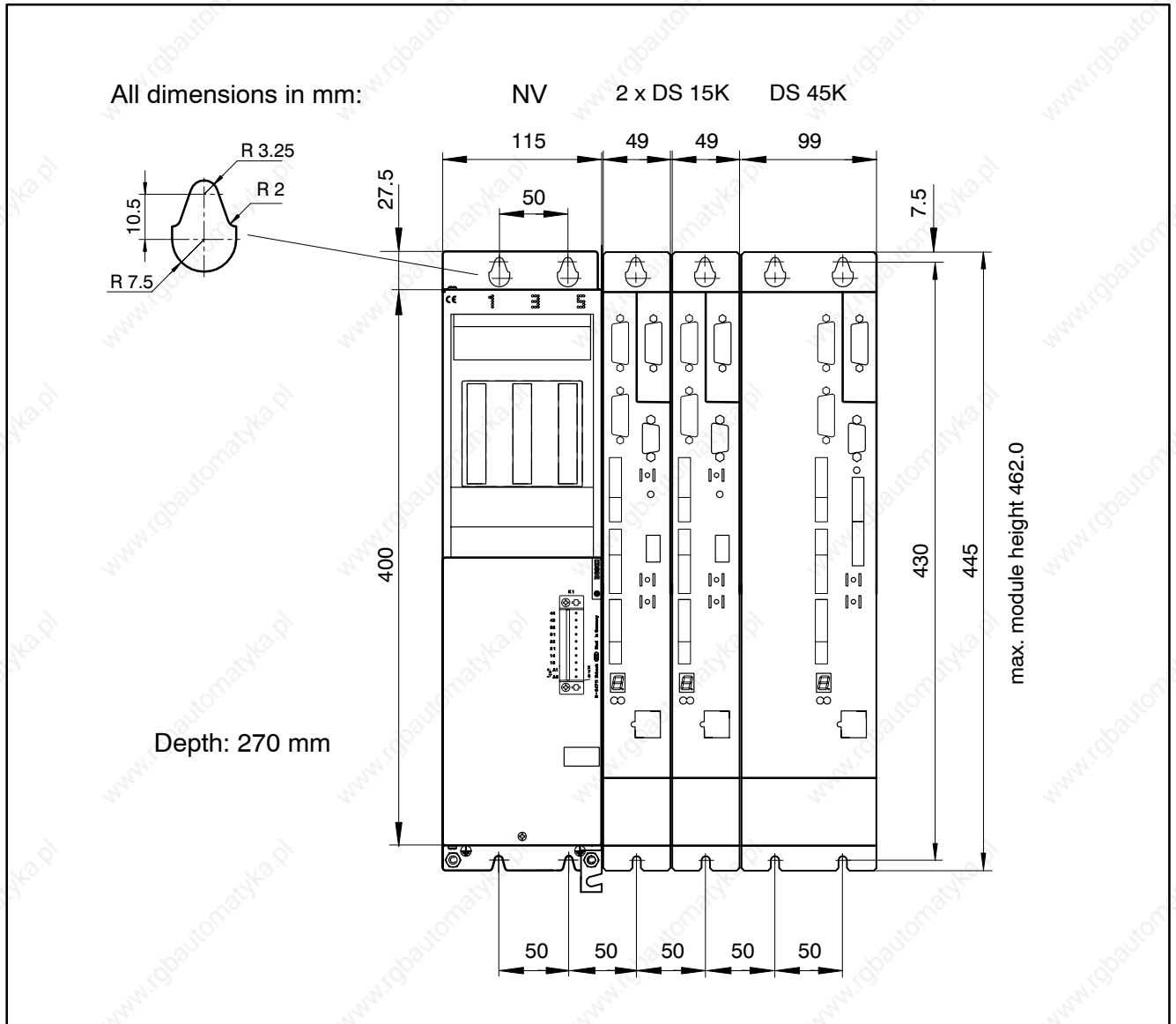

Dimensioned drawings

10.2 Dimensioned drawing, plug braking modules

Part no.	1070 913 544	1070 913 545	1070 913 546	1070 913 547	1070 914 767	1070 913 862
R _x (± 10%)	8R2 57 Ws	3R3 293 Ws	5R6 261 Ws	3R3 785 Ws	1R 785 Ws	1R 4085 Ws
Dimension A	95 mm					110 mm
Dimension B	163 mm					126 mm

35 mm top hat rail to DIN EN 50022

tie-bar

Circuit diagram

U V W PE

Part numbers

11 Part numbers

11.1 Accessories

Designation	Part no.
Plug braking modules (KSB modules)	refer to 'Configuration' manual
Cables, made-to-measure	Encoder cable Power cable Encoder simulation, 14-wire Direct measuring system OM1 / OM2, 8-wire
	refer to 'Configuration' manual 1070 919 938 (2 m) 1070 919 939 (3 m) 1070 919 940 (5 m) 1070 919 935 (2 m) 1070 919 936 (3 m) 1070 919 937 (5 m)
Shield connection link for power cable	1070 919 053
Cable bushing (metal flange)	Encoder cable Power cable
	1070 920 201 1070 920 202
Mating connector encoder simulation	1070 083 525
MBC, brake connection	with relay and protective circuitry
	1070 084 352
Protective circuitry holding brake	with point-to-point terminal
	1070 078 595
Optical fibres for SERCOS interface, made-to-measure	refer to 'Configuration' manual
CAN cable for rho3, D-sub 15-pin CAN cable for rho4, CANopen, D-sub 9-pin	refer to 'Configuration' manual
Commissioning and service system DSS-D, CD-ROM	1070 083 817
Connection cable for PC, 5 m with 9-pole D-Sub connector	1070 077 753

Part numbers

11.2 Options

Designation		Part no.
Option modules direct measuring system:	OM 01 -D	1070 070 937
	OM 02 -D	1070 070 939
	OM 03 -D	1070 078 337
	OM 03 -D (125 kHz, preferred option)	1070 081 927
Option module analog outputs:	OM 04 -D	1070 078 832
Cable, made-to-measure	OM 01 and OM 02	1070 919 935
Mating connector	OM 03	1070 077 197

11.3 Spare fuses

Designation		Part no.
Fuses for	NV 20	3 x 1070 918 727
	NV 21, UL/CSA-certified	3 x 1070 920 862

Appendix

A Appendix**A.1 Index****Numbers**

- 24 V load power supply unit, 2-1
- 24 V supply, 5-10
- 7-segment display DS. See Manual "Diagnostics ServoDyn-D"

A

- Absolute encoder position, Transmission via X81, 8-7
- Ambient air, 2-2
- Autotransformer, 5-7

B

- Brake connection
 - Brake supply filter with/without point-to-point terminal, 5-17
 - with relay and protective circuitry, 5-18

C

- Cable bushing
 - Encoder cable, 7-34
 - Power connection to the motor, 5-12
- Cables, Direct measuring system, 11-2
- CAN bus
 - Baudrate, 7-15
 - Connection, 7-13
 - LED display, 7-15
- CAN connectors, 7-15
- Charging relay, feedback, 6-4
- Connection overview, 4-1
- Connection X05, 7-33
- Connection X51, 7-13, 7-19
- Connections overview
 - Analog interface, 7-1
 - CAN bus, 7-10
 - DS..8001 (ASM), 7-20
 - Positioning function (MC), 7-1
 - PROFIBUS-DP, 7-16
 - SERCOS interface, 7-7
 - Supply module, 6-1
- Current reduction, 7-23
- Cycle off / on upon entering a protective zone, Sequence diagram with SERCOS interface, 8-3
- Cycle on / off, Sequence diagram with SERCOS interface, 8-2

D

- D-Sub connector
 - CAN bus, 7-13
 - Direct measuring system, 7-39
 - Encoder switch/encoder simulation, 7-38
 - Motor encoder, 7-33
 - OM 01, 7-41
 - OM 02, 7-43
 - OM 02 for pulse-shape electronics (EXE), 7-44
 - OM 03 for measuring systems with EnDat interface, 7-46
 - OM 03 for measuring systems with I2C interface, 7-47
 - PROFIBUS-DP, 7-19
 - RS 232, 7-32
- DC link connection, 5-11
- Dimensions
 - DS..K, 3-1, 10-1
 - Line wiring module, 10-1
 - Plug braking modules, 10-2
- DIP switches, 9-2
- Direct current brake, 7-22
- Direct measuring system, 7-39
 - absolute, with EnDat interface, 7-45
 - with sinusoidal current signals, 7-40
 - with sinusoidal voltage signals, 7-45
 - with square-wave signals, 7-42
- Documentation, 1-7
- Drive components, 2-1
 - Layout, 2-3
- Drive operation signals
 - Drive enable (software), 8-1
 - Drive hold (software), 8-1
 - Drive on (software), 8-1
 - Enable FG (hardware), 8-1, 8-6

E

- Earth-leakage circuit-breaker, 5-4
- Earthing, 5-1
 - 24 V power supply unit, 5-3
 - Connection between the modules, 3-2
 - Protective earthing of inverters, 5-1
 - Protective earthing of motors, 5-2
- Electrical connection, Block diagram, 4-1
- EMC, 5-3
- EMC Directive, 1-1
- EMC product standard, 1-1

Appendix

EMERGENCY-STOP, 6-3

- Behavior with SERCOS interface, 8-4
- Sequence diagram with SERCOS interface, 8-5
- Tripping delay, 8-4

EMERGENCY-STOP devices, 1-5

EMERGENCY-STOP switchgear

- Connection with other interfaces, 6-7
- Connection with SERCOS interface, 6-8

Encoder cable

- Pin assignment gear encoder, 7-36
- Pin assignment resolver, 7-36
- Pin assignment STG/MTG, 7-35

Encoder simulation

- Pin assignment, 7-38
- Technical data, 7-37
- Transmission of the absolute encoder position, 8-7

Encoder switch, 7-37

- Pin assignment, 7-38

ESD

- Electrostatic discharge, 1-6
 - grounding, 1-6
 - workplace, 1-6

ESD-sensitive components, 1-6

External enable, 7-2, 7-8, 7-11, 7-17, 7-21, 8-1, 8-6

F

Frequency warning, 7-27

Fuses, 11-2

G

Gear encoders, Permitted types, 7-33

Grounding bracelet, 1-6

H

High-speed analog outputs, 7-48

Holding brake, Control, 7-29

I

Installation, DS..K, 3-1

Intended use, 1-1

Inverter, Function, 2-1

IT protective system, 5-1

L

Limit current, 7-23

Limit switches, 7-9

Line cross section, Supply, 5-8

Line wiring module, 2-1

- Block diagram, 5-8

Low-Voltage Directive, 1-1

Low-voltage supply, 5-9

M

Machinery directive, 1-1

Mains connection

- Autotransformer, 5-7
- Line cross section, 5-8
- Low-voltage supply, 5-9
- NV line wiring module, 5-8

Mains filter, 5-8

- Function, 2-1

Mains supply, 5-5

Measuring probe input, 6-4

Message, Mains failure, 6-4

Modules sensitive to electrostatic discharge. *See*

- ESD-sensitive components

Motor cables, 5-12

Motor connection

- Asynchronous motors, 5-20
- Servo motors, 5-12

Motor encoder

- Connection, 7-33
- Pin assignment gear encoder, 7-36
- Pin assignment resolver, 7-36
- Pin assignment STG/MTG, 7-35

O

Option module

- OM 01, 7-40
- OM 02, 7-42
- OM 04, 7-48

P

Parameter list, 7-22

Personality module, 9-1

Plug braking contactor, Control, 7-28

Plug braking modules, Dimensions, 10-2

Plug-in connection X71/72, 7-9

PROFIBUS-DP

- Address, 7-19
- Connection, 7-19
- LED display, 7-19

Protective earth conductor cross-section, 5-2

Protective earthing, 5-1

Q

Qualified personnel, 1-2

R

Reference point switch, 7-9

Release, 1-7

Rotary switches S2...S4, 7-19

Rotary switches S2...S5, 7-15

S

Safety instructions, 1-4

Safety markings, 1-3

Safety relay, feedback, 6-5

Safety separation, 2-1, 5-10

SERCOS interface, Connection, 7-9

Appendix

Set-up mode

Wiring with other interfaces, 6-7

Wiring with SERCOS interface, 6-8

Spare parts, 1-6

Special mode, 6-4

Stability warning, 7-23

Standstill monitoring, 7-27

Start logically linked

Inverters with other interfaces, 6-7

Inverters with SERCOS interface, 6-8

Status message, 7-2, 7-8, 7-11, 7-17, 7-21

Switch cabinet structure, 2-1

Example of a possible layout, 2-4

T

Temperature warning

all inverters without ASM, 7-31

ASM, 7-23

Terminal box, 5-20

Terminal strip X06

Analog interface, 7-2

CAN bus, 7-11

Frequency inverter, 7-21

Motion Control, 7-2

PROFIBUS-DP, 7-17

SERCOS interface, 7-8

Terminal strip X12, 7-6

Terminal strip X13, 7-23

Terminal strip X14, OM 04, 7-48

Terminal strip X21, 7-4

Terminal strip X22, 7-5

Terminal strip X23, 7-24

Terminal strip X30, 6-3

Terminal strip X312, 6-3

Terminal strip X34, 7-28

Terminal strip X34 (ASM), 7-27

Terminal strip X76, 6-5

Test activities, 1-6

Trademarks, 1-8

U

UL/CSA certification, Installation and operation, 2-5

Appendix
Notes:

Rexroth
Bosch Group

Bosch Rexroth AG
Electric Drives and Controls
P.O. Box 13 57
97803 Lohr, Germany
Bgm.-Dr.-Nebel-Str. 2
97816 Lohr, Germany
Phone +49 (0)93 52-40-50 60
Fax +49 (0)93 52-40-49 41
service.svc@boschrexroth.de
www.boschrexroth.com



1070066036

Printed in Germany
DOK-SERV*D-STAND*ALONE-MA03-EN-P